

SECTION **SB**
SEAT BELT

A
B
C
D
E
F
G
SB
I
J
K
L
M
N
O
P

CONTENTS

PRECAUTION	2	FOR MEXICO : Precautions For Xenon Headlamp Service	4
PRECAUTIONS	2	FOR MEXICO : Precautions for Removing Battery Terminal	5
EXCEPT FOR MEXICO	2	FOR MEXICO : Precaution for Seat Belt Service.....	5
EXCEPT FOR MEXICO : Precautions for Supplemental Restraint System (SRS) "AIR BAG" and "SEAT BELT PRE-TENSIONER"	2	REMOVAL AND INSTALLATION	6
EXCEPT FOR MEXICO : Precaution for Battery Service	2	SEAT BELT	6
EXCEPT FOR MEXICO : Precautions For Xenon Headlamp Service	2	SEAT BELT RETRACTOR	6
EXCEPT FOR MEXICO : Precautions for Removing Battery Terminal	3	SEAT BELT RETRACTOR : Inspection	6
EXCEPT FOR MEXICO : Precaution for Seat Belt Service	3	SEAT BELT RETRACTOR : Exploded View	8
FOR MEXICO	3	SEAT BELT RETRACTOR : Removal and Installation	9
FOR MEXICO : Precaution for Supplemental Restraint System (SRS) "AIR BAG" and "SEAT BELT PRE-TENSIONER"	3	SEAT BELT BUCKLE	10
FOR MEXICO : Precaution for Battery Service	4	SEAT BELT BUCKLE : Inspection	10
		SEAT BELT BUCKLE : Exploded View	11
		SEAT BELT BUCKLE : Removal and Installation.....	11
		LATCH SYSTEM FOR CHILDREN	12
		Exploded View	12
		Removal and Installation	12

PRECAUTIONS

< PRECAUTION >

PRECAUTION

PRECAUTIONS

EXCEPT FOR MEXICO

EXCEPT FOR MEXICO : Precautions for Supplemental Restraint System (SRS) "AIR BAG" and "SEAT BELT PRE-TENSIONER"

INFOID:000000010840621

The Supplemental Restraint System such as "AIR BAG" and "SEAT BELT PRE-TENSIONER", used along with a front seat belt, helps to reduce the risk or severity of injury to the driver and front passenger for certain types of collision. This system includes seat belt switch inputs and dual stage front air bag modules. The SRS system uses the seat belt switches to determine the front air bag deployment, and may only deploy one front air bag, depending on the severity of a collision and whether the front occupants are belted or unbelted.

Information necessary to service the system safely is included in the "SRS AIR BAG" and "SEAT BELT" of this Service Manual.

WARNING:

Always observe the following items for preventing accidental activation.

- To avoid rendering the SRS inoperative, which could increase the risk of personal injury or death in the event of a collision that would result in air bag inflation, all maintenance must be performed by an authorized NISSAN/INFINITI dealer.
- Improper maintenance, including incorrect removal and installation of the SRS, can lead to personal injury caused by unintentional activation of the system. For removal of Spiral Cable and Air Bag Module, see "SRS AIR BAG".
- Never use electrical test equipment on any circuit related to the SRS unless instructed to in this Service Manual. SRS wiring harnesses can be identified by yellow and/or orange harnesses or harness connectors.

PRECAUTIONS WHEN USING POWER TOOLS (AIR OR ELECTRIC) AND HAMMERS

WARNING:

Always observe the following items for preventing accidental activation.

- When working near the Air Bag Diagnosis Sensor Unit or other Air Bag System sensors with the ignition ON or engine running, never use air or electric power tools or strike near the sensor(s) with a hammer. Heavy vibration could activate the sensor(s) and deploy the air bag(s), possibly causing serious injury.
- When using air or electric power tools or hammers, always switch the ignition OFF, disconnect the battery, and wait at least 3 minutes before performing any service.

EXCEPT FOR MEXICO : Precaution for Battery Service

INFOID:000000010840622

Before disconnecting the battery, lower both the driver and passenger windows. This will prevent any interference between the window edge and the vehicle when the door is opened/closed. During normal operation, the window slightly raises and lowers automatically to prevent any window to vehicle interference. The automatic window function will not work with the battery disconnected.

EXCEPT FOR MEXICO : Precautions For Xenon Headlamp Service

INFOID:000000011337874

WARNING:

Comply with the following warnings to prevent any serious accident.

- Disconnect the battery cable (negative terminal) or the power supply fuse before installing, removing, or touching the xenon headlamp (bulb included). The xenon headlamp contains high-voltage generated parts.
- Never work with wet hands.
- Check the xenon headlamp ON-OFF status after assembling it to the vehicle. Never turn the xenon headlamp ON in other conditions. Connect the power supply to the vehicle-side connector. (Turning it ON outside the lamp case may cause fire or visual impairments.)
- Never touch the bulb glass immediately after turning it OFF. It is extremely hot.

CAUTION:

Comply with the following cautions to prevent any error and malfunction.

- Install the xenon bulb securely. (Insufficient bulb socket installation may melt the bulb, the connector, the housing, etc. by high-voltage leakage or corona discharge.)

PRECAUTIONS

< PRECAUTION >

- Never perform HID circuit inspection with a tester.
- Never touch the xenon bulb glass with hands. Never put oil and grease on it.
- Dispose of the used xenon bulb after packing it in thick vinyl without breaking it.
- Never wipe out dirt and contamination with organic solvent (thinner, gasoline, etc.).

EXCEPT FOR MEXICO : Precautions for Removing Battery Terminal

INFOID:000000011337872

- When removing the 12V battery terminal, turn OFF the ignition switch and wait at least 30 seconds.

NOTE:

ECU may be active for several tens of seconds after the ignition switch is turned OFF. If the battery terminal is removed before ECU stops, then a DTC detection error or ECU data corruption may occur.

- For vehicles with the 2-batteries, be sure to connect the main battery and the sub battery before turning ON the ignition switch.

NOTE:

If the ignition switch is turned ON with any one of the terminals of main battery and sub battery disconnected, then DTC may be detected.

- After installing the 12V battery, always check "Self Diagnosis Result" of all ECUs and erase DTC.

NOTE:

The removal of 12V battery may cause a DTC detection error.

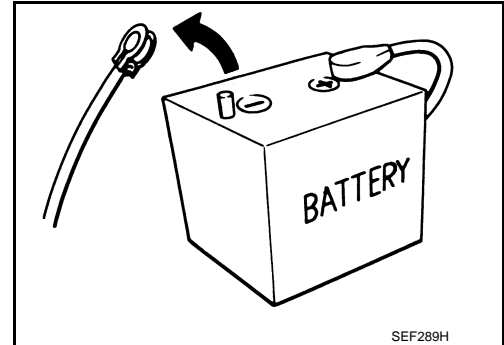

EXCEPT FOR MEXICO : Precaution for Seat Belt Service

INFOID:000000010840623

CAUTION:

- Before removing the front seat belt pre-tensioner assembly, turn the ignition switch OFF, disconnect the battery negative terminal and wait at least 3 minutes.
- Never use electrical test equipment for front seat belt pre-tensioner connector.
- After replacing or reinstalling front seat belt pre-tensioner assembly, or reconnecting front seat belt pre-tensioner connector, check the system function. Refer to [SRC-107, "Diagnosis Description"](#).
- Never use disassembled buckle or seat belt assembly.
- Replace anchor bolts if they are deformed or worn out.
- Never oil tongue and buckle.
- If any component of seat belt assembly is questionable, never repair. Replace the entire seat belt assembly.
- If webbing is cut, frayed or damaged, replace seat belt assembly.
- When replacing seat belt assembly, use a Genuine NISSAN seat belt assembly.

AFTER A COLLISION

WARNING:

Inspect all seat belt assemblies including retractors and attached hardware after any collision. NISSAN recommends that all seat belt assemblies in use during a collision be replaced unless the collision was minor and the belts show no damage and continue to operate properly. Failure to do so could result in serious personal injury in an accident. Seat belt assemblies not in use during a collision should also be replaced if either damage or improper operation is noted. Seat belt pre-tensioners should be replaced even if the seat belts are not in use during a frontal collision in which the air bags are deployed.

Replace any seat belt assembly (including anchor bolts) if:

- The seat belt is in use at the time of a collision (except for minor collisions and the belts, retractors and buckles show no damage and continue to operate properly).
- The seat belt is damaged in an accident (i.e. torn webbing, bent retractor or guide).
- The seat belt attaching point is damaged in an accident. Inspect the seat belt attaching area for damage or distortion and repair as necessary before installing a new seat belt assembly.
- Anchor bolts are deformed or worn out.
- The front seat belt pre-tensioner must be replaced even if the seat belts are not in use during the collision in which the air bags are deployed.

FOR MEXICO

FOR MEXICO : Precaution for Supplemental Restraint System (SRS) "AIR BAG" and

PRECAUTIONS

< PRECAUTION >

"SEAT BELT PRE-TENSIONER"

INFOID:0000000110840624

The Supplemental Restraint System such as "AIR BAG" and "SEAT BELT PRE-TENSIONER", used along with a front seat belt, helps to reduce the risk or severity of injury to the driver and front passenger for certain types of collision. Information necessary to service the system safely is included in the "SRS AIR BAG" and "SEAT BELT" of this Service Manual.

WARNING:

Always observe the following items for preventing accidental activation.

- To avoid rendering the SRS inoperative, which could increase the risk of personal injury or death in the event of a collision that would result in air bag inflation, all maintenance must be performed by an authorized NISSAN/INFINITI dealer.
- Improper maintenance, including incorrect removal and installation of the SRS, can lead to personal injury caused by unintentional activation of the system. For removal of Spiral Cable and Air Bag Module, see "SRS AIR BAG".
- Never use electrical test equipment on any circuit related to the SRS unless instructed to in this Service Manual. SRS wiring harnesses can be identified by yellow and/or orange harnesses or harness connectors.

PRECAUTIONS WHEN USING POWER TOOLS (AIR OR ELECTRIC) AND HAMMERS

WARNING:

Always observe the following items for preventing accidental activation.

- When working near the Air Bag Diagnosis Sensor Unit or other Air Bag System sensors with the ignition ON or engine running, never use air or electric power tools or strike near the sensor(s) with a hammer. Heavy vibration could activate the sensor(s) and deploy the air bag(s), possibly causing serious injury.
- When using air or electric power tools or hammers, always switch the ignition OFF, disconnect the battery, and wait at least 3 minutes before performing any service.

FOR MEXICO : Precaution for Battery Service

INFOID:0000000110840625

Before disconnecting the battery, lower both the driver and passenger windows. This will prevent any interference between the window edge and the vehicle when the door is opened/closed. During normal operation, the window slightly raises and lowers automatically to prevent any window to vehicle interference. The automatic window function will not work with the battery disconnected.

FOR MEXICO : Precautions For Xenon Headlamp Service

INFOID:000000011337875

WARNING:

Comply with the following warnings to prevent any serious accident.

- Disconnect the battery cable (negative terminal) or the power supply fuse before installing, removing, or touching the xenon headlamp (bulb included). The xenon headlamp contains high-voltage generated parts.
- Never work with wet hands.
- Check the xenon headlamp ON-OFF status after assembling it to the vehicle. Never turn the xenon headlamp ON in other conditions. Connect the power supply to the vehicle-side connector. (Turning it ON outside the lamp case may cause fire or visual impairments.)
- Never touch the bulb glass immediately after turning it OFF. It is extremely hot.

CAUTION:

Comply with the following cautions to prevent any error and malfunction.

- Install the xenon bulb securely. (Insufficient bulb socket installation may melt the bulb, the connector, the housing, etc. by high-voltage leakage or corona discharge.)
- Never perform HID circuit inspection with a tester.
- Never touch the xenon bulb glass with hands. Never put oil and grease on it.
- Dispose of the used xenon bulb after packing it in thick vinyl without breaking it.
- Never wipe out dirt and contamination with organic solvent (thinner, gasoline, etc.).

PRECAUTIONS

< PRECAUTION >

FOR MEXICO : Precautions for Removing Battery Terminal

INFOID:000000011337873

- When removing the 12V battery terminal, turn OFF the ignition switch and wait at least 30 seconds.

NOTE:

ECU may be active for several tens of seconds after the ignition switch is turned OFF. If the battery terminal is removed before ECU stops, then a DTC detection error or ECU data corruption may occur.

- For vehicles with the 2-batteries, be sure to connect the main battery and the sub battery before turning ON the ignition switch.

NOTE:

If the ignition switch is turned ON with any one of the terminals of main battery and sub battery disconnected, then DTC may be detected.

- After installing the 12V battery, always check "Self Diagnosis Result" of all ECUs and erase DTC.

NOTE:

The removal of 12V battery may cause a DTC detection error.

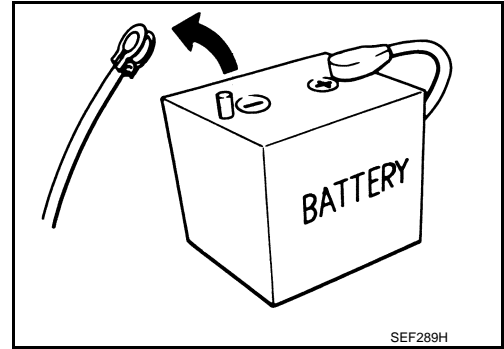

FOR MEXICO : Precaution for Seat Belt Service

INFOID:000000010840626

CAUTION:

- Before removing the front seat belt pre-tensioner assembly, turn the ignition switch OFF, disconnect the battery negative terminal and wait at least 3 minutes.
- Never use electrical test equipment for front seat belt pre-tensioner connector.
- After replacing or reinstalling front seat belt pre-tensioner assembly, or reconnecting front seat belt pre-tensioner connector, check the system function. Refer to [SRC-107, "Diagnosis Description"](#).
- Never use disassembled buckle or seat belt assembly.
- Replace anchor bolts if they are deformed or worn out.
- Never oil tongue and buckle.
- If any component of seat belt assembly is questionable, never repair. Replace the entire seat belt assembly.
- If webbing is cut, frayed or damaged, replace seat belt assembly.
- When replacing seat belt assembly, use a Genuine NISSAN seat belt assembly.

AFTER A COLLISION

WARNING:

Inspect all seat belt assemblies including retractors and attached hardware after any collision. NISSAN recommends that all seat belt assemblies in use during a collision be replaced unless the collision was minor and the belts show no damage and continue to operate properly. Failure to do so could result in serious personal injury in an accident. Seat belt assemblies not in use during a collision should also be replaced if either damage or improper operation is noted. Seat belt pre-tensioners should be replaced even if the seat belts are not in use during a frontal collision in which the air bags are deployed.

Replace any seat belt assembly (including anchor bolts) if:

- The seat belt is in use at the time of a collision (except for minor collisions and the belts, retractors and buckles show no damage and continue to operate properly).
- The seat belt is damaged in an accident (i.e. torn webbing, bent retractor or guide).
- The seat belt attaching point is damaged in an accident. Inspect the seat belt attaching area for damage or distortion and repair as necessary before installing a new seat belt assembly.
- Anchor bolts are deformed or worn out.
- The front seat belt pre-tensioner must be replaced even if the seat belts are not in use during the collision in which the air bags are deployed.

SEAT BELT

< REMOVAL AND INSTALLATION >

REMOVAL AND INSTALLATION

SEAT BELT

SEAT BELT RETRACTOR

SEAT BELT RETRACTOR : Inspection

INFOID:000000010840627

AFTER A COLLISION

WARNING:

Inspect all seat belt assemblies including retractors and attached hardware after any collision.

NISSAN/INFINITI recommends that all seat belt assemblies in use during a collision be replaced unless the collision was minor and the belts show no damage and continue to operate normally. Not doing so could result in serious personal injury in an accident. Seat belt assemblies not in use during a collision should also be replaced if either damage or improper operation was noted. Seat belt pre-tensioners must be replaced even if the seat belts were not in use during a frontal collision in which the air bags were deployed.

Replace any seat belt assembly (including anchor bolts) if:

- The seat belt is in use at the time of a collision (except for minor collisions and the belts, retractors and buckles show no damage and continue to operate normally).
- The seat belt is damaged in an accident (i.e. torn webbing, bent retractor or guide, etc.).
- The seat belt attaching point is damaged in an accident. Inspect the seat belt attaching area for damage or distortion and repair if necessary before installing a new seat belt assembly.
- Anchor bolts are deformed or worn out.
- The seat belt pre-tensioners must be replaced even if the seat belts were not in use during the collision in which the air bags were deployed.

PRELIMINARY CHECKS

1. Check the seat belt warning lamp for normal operation as per the following items:
 - a. Turn ignition switch ON. The seat belt warning lamp should illuminate.
 - b. Fasten driver seat belt. The seat belt warning lamp should turn OFF.
2. If the air bag warning lamp is blinking, perform self-diagnosis with CONSULT and air bag warning lamp. Refer to [SRC-107, "Diagnosis Description"](#).
3. Check that the seat belt retractor, seat belt anchor and buckle bolts are tightened firmly.
4. Check the shoulder seat belt guide and shoulder belt height adjuster for front seats. Check that guide swivels freely and that webbing lays flat and does not bind in guide. Check that height adjuster operates normally and holds securely.
5. Check retractor operation:
 - a. Fully extend the seat belt webbing and check for twists, tears, or other damage.
 - b. Allow the seat belt to retract. Check that webbing returns smoothly and completely into the retractor. If the seat belt does not return smoothly, wipe the inside of the loops with a clean paper cloth. Dirt build-up in the loops of the upper anchors can cause the seat belts to retract slowly.
 - c. Fasten the seat belt. Check that seat belt returns smoothly and completely to the retractor. If the webbing does not return smoothly, the cause may be an accumulation of dust or dirt. Use the "SEAT BELT TAPE SET" and perform the following steps.

Inspect the seat belt through-anchor

1. Pull the seat belt out to a length of 500 mm (19.685 in) or more.
2. Fix the seat belt at the center pillar webbing opening with a clip or other device.
3. Pass a thin wire through the through-anchor webbing opening. Hold both ends of the wire and pull it tightly while moving it up and down several times along the webbing opening surface to remove dirt stuck there.
4. Any dirt that cannot be removed with the wire can be removed by cleaning the opening with a clean cloth.
5. Apply tape at the point where the webbing contacts the through-anchor webbing opening.

NOTE:
Apply the tape so that there is no slack or wrinkling.
6. Remove the clip fixing the seat belt and check that the webbing returns smoothly.
6. Repeat steps above if necessary to check the other seat belts.

SEAT BELT

< REMOVAL AND INSTALLATION >

SEAT BELT RETRACTOR ON-VEHICLE CHECK

Emergency Locking Retractors (ELR)

NOTE:

All seat belt retractors are Emergency Locking Retractors (ELR) type. In an emergency (sudden stop) the retractor locks and prevents the webbing from extending any further.

Check the seat belt retractors with the following test(s) to determine if a retractor assembly is operating normally.

ELR Function Stationary Check

Grasp the shoulder webbing and pull forward quickly. The retractor should lock and prevent the belt from extending further.

ELR Function Moving Check

WARNING:

Perform the following test in a safe, open area clear of other vehicles and obstructions (for example, a large, empty parking lot). Road surface must be paved and dry. Never perform the following test on wet or gravel roads, public streets, or highways. This could result in an accident and serious personal injury. The driver and passenger must be prepared to brace themselves in the event that the retractor does not lock.

1. Fasten driver seat belt. Buckle a passenger into the seat for the belt that is to be tested.
2. Proceed to the designated safe area.
3. Drive the vehicle at approximately 16 km/h (10 MPH). Notify any passengers of a pending sudden stop and the driver and passenger must be prepared to brace themselves in the event that the retractor does not lock. Apply brakes firmly and make a very hard stop.

During stopping, seat belts should lock and not be extended. If the seat belt retractor assembly does not lock, perform the retractor off-vehicle check.

SEAT BELT RETRACTOR OFF-VEHICLE CHECK

1. Remove seat belt retractor. Refer to [SB-9, "SEAT BELT RETRACTOR : Removal and Installation"](#).
2. Slowly pull out webbing while tilting the retractor assembly forward from the mounted position without twisting the retractor assembly as shown in the figure.
 - The webbing can be pulled out when the angle (A) is 15 degrees or less.
 - The webbing cannot be pulled out when the angle (B) is 27 degrees or more.

A and B : Tilting angles

← : Vehicle front

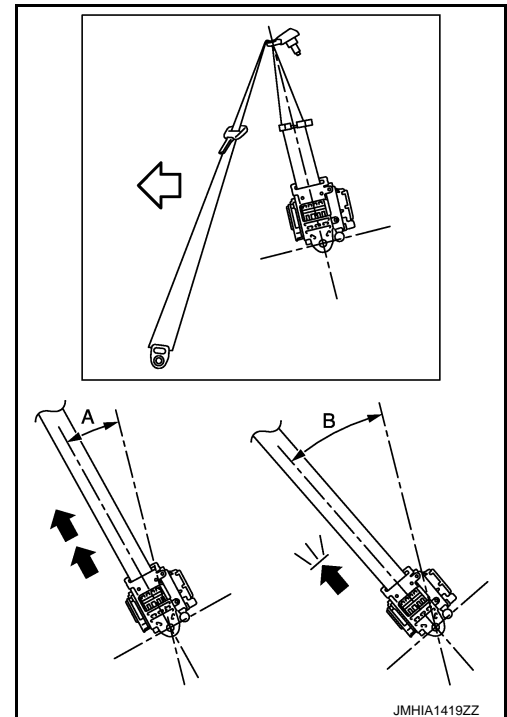

3. Replace the seat belt assembly if it does not operate normally.

SEAT BELT

< REMOVAL AND INSTALLATION >

SEAT BELT RETRACTOR : Exploded View

INFOID:000000010840628

Coupe models

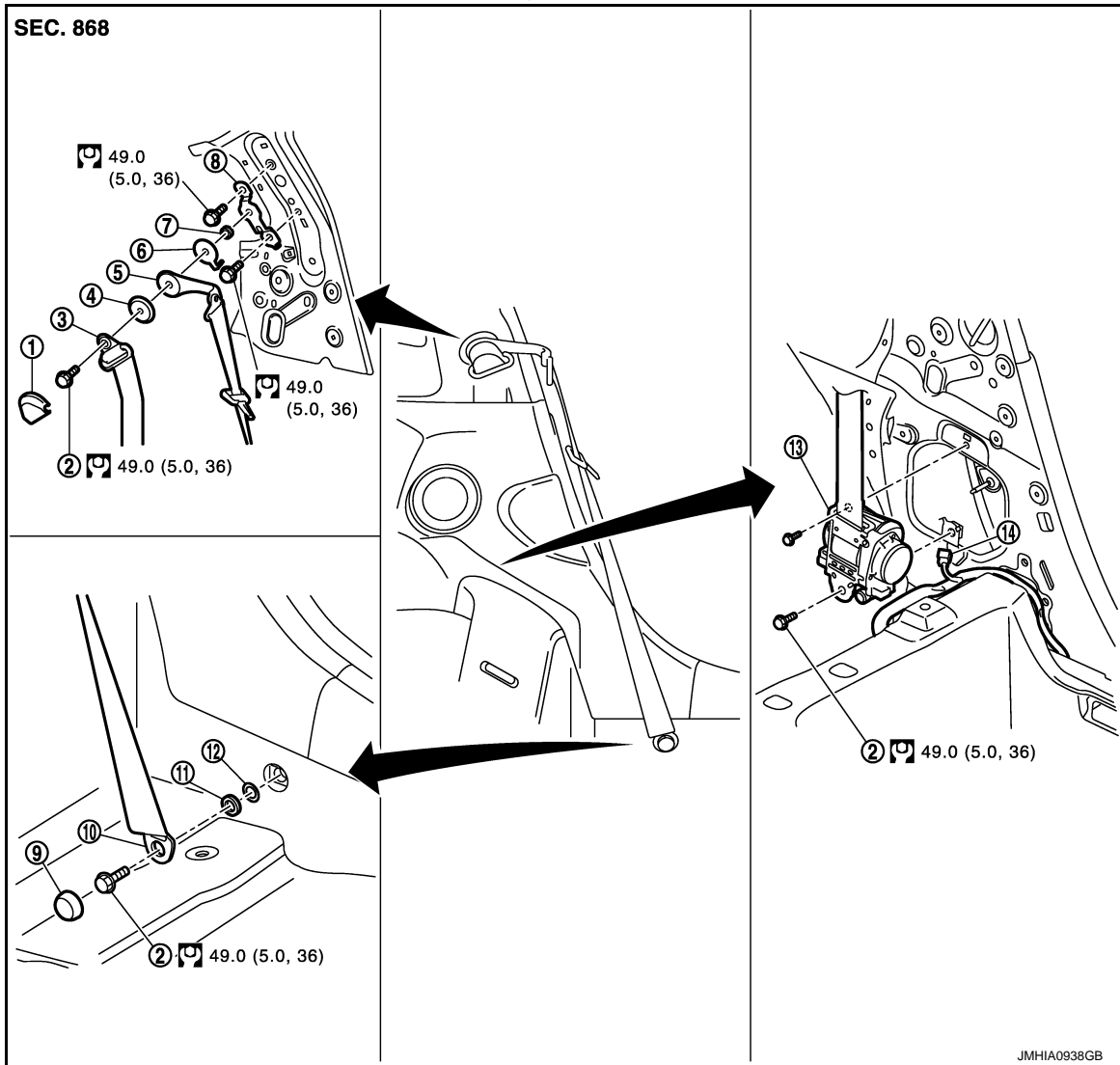

JMHIA0938GB

- | | | |
|---------------------------------------|---------------------------------------|------------------------------------|
| 1. Shoulder anchor cover | 2. Anchor bolt | 3. Shoulder anchor |
| 4. Seat belt extension arm cover | 5. Seat belt extension arm | 6. Seat belt extension arm bracket |
| 7. Spacer | 8. Shoulder anchor bracket | 9. Anchor cover |
| 10. Outer anchor | 11. Spacer | 12. Retaining washer |
| 13. Seat belt pre-tensioner retractor | 14. Seat belt pre-tensioner connector | |

 : N·m (kg-m, ft-lb)

SEAT BELT

< REMOVAL AND INSTALLATION >

Roadster models

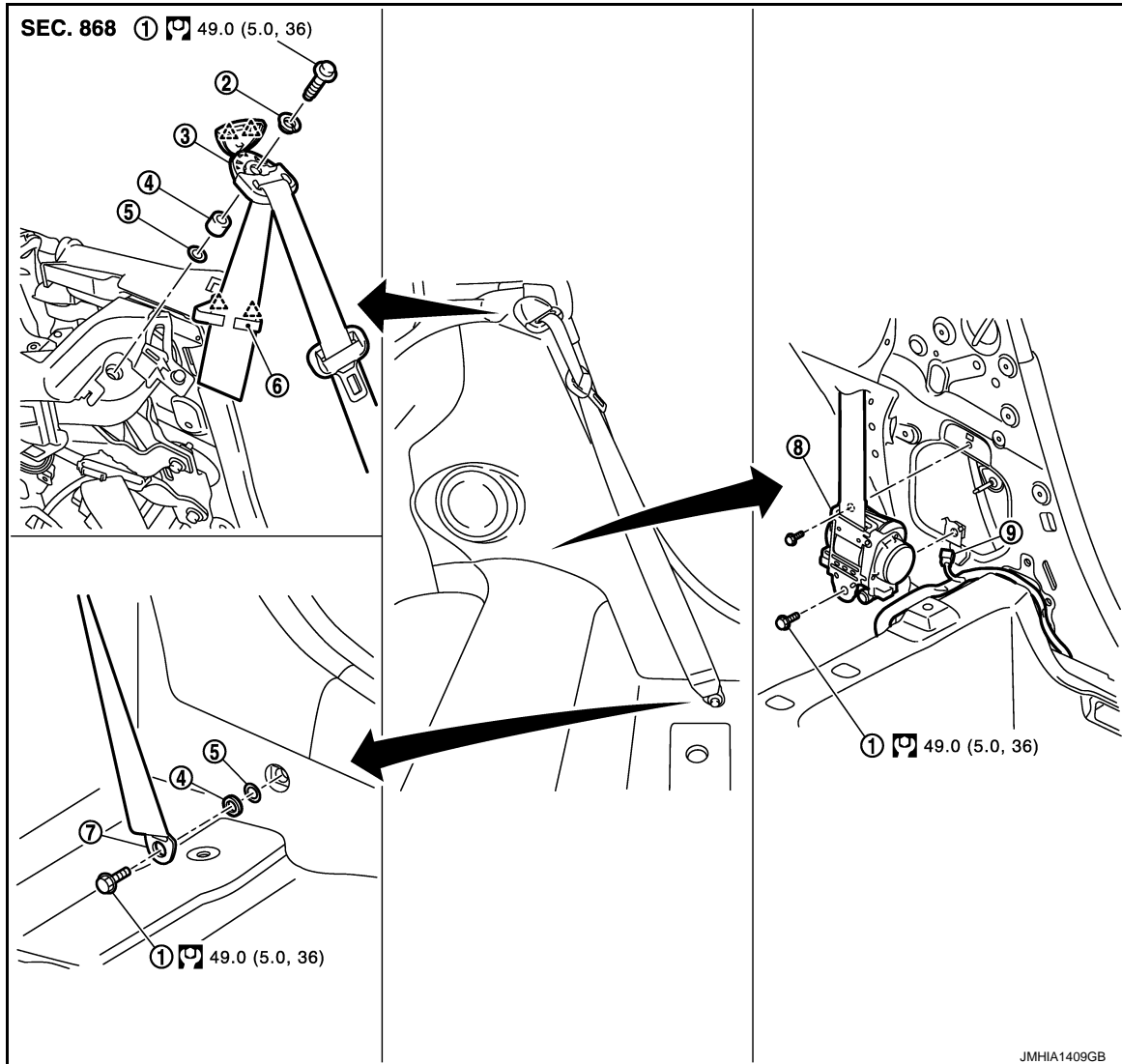

- | | | |
|-----------------|--------------------------------------|--------------------------------------|
| 1. Anchor bolt | 2. Silencer washer | 3. Shoulder anchor cover |
| 4. Spacer | 5. Retaining washer | 6. Seat belt guide |
| 7. Outer anchor | 8. Seat belt pre-tensioner retractor | 9. Seat belt pre-tensioner connector |

 : Pawl

 : N·m (kg·m, ft·lb)

SEAT BELT RETRACTOR : Removal and Installation

INFOID:000000010840629

REMOVAL

CAUTION:

Before removal or installation, always turn the ignition switch OFF and disconnect the battery negative terminal, then wait for at least 3 minutes or more.

1. Remove the outer anchor.
 - Remove the anchor cover (coupe models).
 - Remove the outer anchor mounting anchor bolt.
2. Remove the shoulder anchor.
 - Remove the shoulder anchor cover (coupe models).
 - Disengage the shoulder anchor cover fixing pawls (roadster models).
 - Remove the shoulder anchor mounting anchor bolt.
3. Remove the rear side finisher. Refer to [INT-21. "REAR SIDE FINISHER : Removal and Installation"](#) (coupe models) or [INT-54. "REAR SIDE FINISHER : Removal and Installation"](#) (roadster models).

SEAT BELT

< REMOVAL AND INSTALLATION >

4. Remove the seat belt pre-tensioner retractor.
 - Disconnect the seat belt pre-tensioner connector.

CAUTION:

- For installing or removing the seat belt pre-tensioner connector, insert a flat-bladed screwdriver wrapped in tape into notch, lift lock and remove the connector.
- Install the connector with lock raised, and push lock into the connector.
- After installing the connector, check that the lock is pushed securely into it.

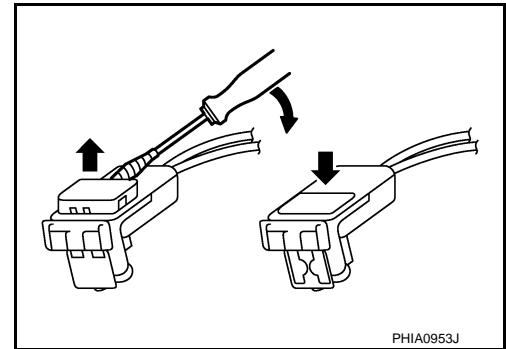

5. Remove seat belt guide (1) (roadster models).
 - Remove rear side finisher (roadster models). Refer to [INT-54](#), "[REAR SIDE FINISHER : Removal and Installation](#)".
 - Remove seat belt through the seat belt guide gap.
 - Disengage seat belt guide fixing pawls with a remover tool (A) and then remove seat belt guide.

 : Pawl

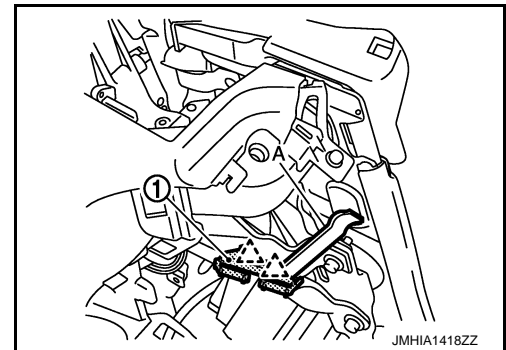

INSTALLATION

Install in the reverse order of removal.

SEAT BELT BUCKLE

SEAT BELT BUCKLE : Inspection

INFOID:000000010840630

Post-accident inspection

After a collision, check all parts of the installed seat belt assembly (including the retractor). Then, check the installed seat belt portion for damage or deformation. When a collision occurs, damage/deformation is detected, or operation is not normal, and NISSAN recommends replacement of seat belt assembly. If replacement is not performed, serious personal injury may occur.

If the following conditions occur, replace the seat belt:

- When the seat belt is damaged
- When the installed seat belt portion is damaged (before installing a new seat belt, check the installed portion for damage or deformation)
- When an air bag is deployed in an accident whether it is used or not (only for models with seat belt pre-tensioner)
- When the seat belt does not operate normally

Preliminary check

1. Using the seat belt warning lamp, check that the seat belt buckle switch operates normally.
When the ignition switch is turned ON with the seat belt not in use, the seat belt warning lamp turns ON.
When the seat belt is fastened, the seat belt warning lamp turns OFF.
2. Check that anchor bolts on the seat belt retractor and buckle are securely tightened.

SEAT BELT

< REMOVAL AND INSTALLATION >

SEAT BELT BUCKLE : Exploded View

INFOID:000000010840631

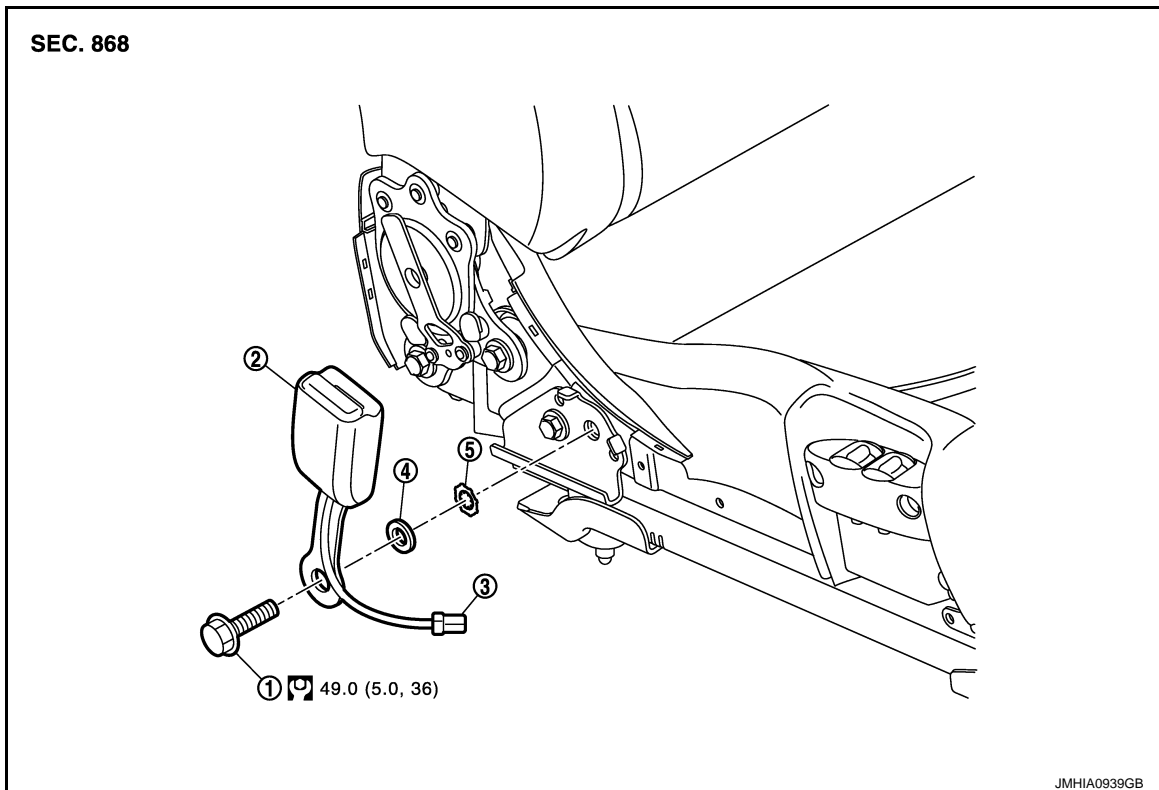

- | | | |
|-----------------|---------------------|--------------------------------------|
| 1. Anchor bolt | 2. Seat belt buckle | 3. Seat belt buckle switch connector |
| 4. Plain washer | 5. Retaining washer | |

 : N·m (kg-m, ft-lb)

SEAT BELT BUCKLE : Removal and Installation

INFOID:000000010840632

REMOVAL

1. Remove seat assembly from the vehicle. Refer to [SE-88. "Removal and Installation"](#).
2. Remove seat belt buckle.
 - Remove seat cushion inner finisher. Refer to [SE-94. "SEAT CUSHION : Disassembly and Assembly"](#).
 - Remove seat belt buckle mounting anchor bolt.

INSTALLATION

Install in the reverse order of removal.

LATCH SYSTEM FOR CHILDREN

< REMOVAL AND INSTALLATION >

LATCH SYSTEM FOR CHILDREN

Exploded View

INFOID:000000010840633

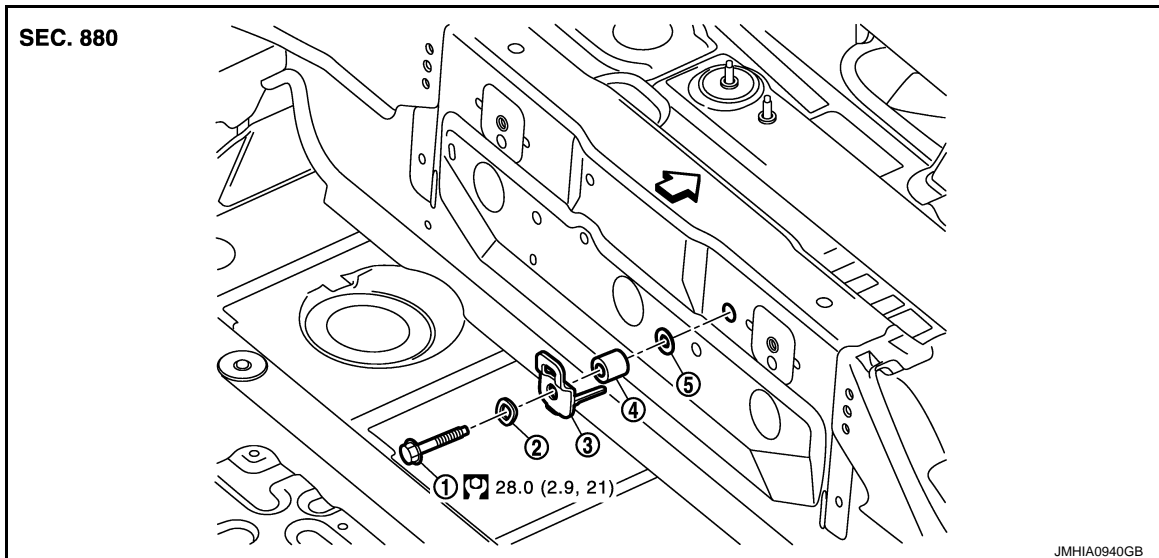

- | | | |
|----------------|-----------------|-----------------|
| 1. Anchor bolt | 2. Wave washer | 3. Anchor plate |
| 4. Spacer | 5. Fiber washer | |

← : Vehicle front

 : N·m (kg-m, ft-lb)

Removal and Installation

INFOID:000000010840634

REMOVAL

CAUTION:

Replace anchor bolts if they are deformed or worn out.

1. Remove the luggage floor carpet. Refer to [INT-32. "Removal and Installation"](#).
2. Remove anchor bolt, and then remove LATCH (Lower Anchor and Tether for Children) system.

INSTALLATION

Install in the reverse order of removal.