

SECTION **VTL**
VENTILATION SYSTEM

A
B
C

CONTENTS

SYSTEM DESCRIPTION	3	SIDE VENTILATOR GRILLE	9	F
VENTILATION SYSTEM	3	SIDE VENTILATOR GRILLE : Removal and Installation	9	G
System Description	3	FRONT DEFROSTER GRILLE	9	H
PRECAUTION	4	FRONT DEFROSTER GRILLE : Removal and Installation	9	I
PRECAUTIONS	4	SIDE DEFROSTER GRILLE	9	J
FOR USA AND CANADA	4	SIDE DEFROSTER GRILLE : Removal and Installation	10	K
FOR USA AND CANADA : Precaution for Supplemental Restraint System (SRS) "AIR BAG" and "SEAT BELT PRE-TENSIONER"	4	VENTILATOR DUCT	10	L
FOR USA AND CANADA : Precaution for Battery Service	4	VENTILATOR DUCT : Removal and Installation	10	M
FOR USA AND CANADA : Precaution for Procedure without Cowl Top Cover	4	SIDE VENTILATOR DUCT	10	N
FOR USA AND CANADA : Precautions for Removing Battery Terminal	5	SIDE VENTILATOR DUCT : Removal and Installation	10	O
FOR MEXICO	5	FRONT DEFROSTER NOZZLE	10	P
FOR MEXICO : Precaution for Supplemental Restraint System (SRS) "AIR BAG" and "SEAT BELT PRE-TENSIONER"	5	FRONT DEFROSTER NOZZLE : Removal and Installation	10	
FOR MEXICO : Precaution for Battery Service	5	SIDE DEFROSTER NOZZLE	11	
FOR MEXICO : Precaution for Procedure without Cowl Top Cover	6	SIDE DEFROSTER NOZZLE : Removal and Installation	11	
FOR MEXICO : Precautions for Removing Battery Terminal	6	FOOT GRILLE	11	
PREPARATION	7	FOOT GRILLE : Removal and Installation	11	
PREPARATION	7	FOOT DUCT	11	
Commercial Service Tool	7	FOOT DUCT : Removal and Installation	11	
REMOVAL AND INSTALLATION	8	BLOWER UNIT	13	
DUCT AND GRILLE	8	Exploded View	13	
Exploded View	8	BLOWER UNIT	14	
CENTER VENTILATOR GRILLE	8	BLOWER UNIT : Removal and Installation	14	
CENTER VENTILATOR GRILLE : Removal and Installation	8	BLOWER MOTOR	15	
CENTER VENTILATOR GRILLE : Removal and Installation	8	BLOWER MOTOR : Removal and Installation	15	
SIDE VENTILATOR GRILLE	9	IN-CABIN MICROFILTER	16	
SIDE VENTILATOR GRILLE : Removal and Installation	9	Exploded View	16	
FRONT DEFROSTER GRILLE	9			
FRONT DEFROSTER GRILLE : Removal and Installation	9			
SIDE DEFROSTER GRILLE	9			
SIDE DEFROSTER GRILLE : Removal and Installation	10			
VENTILATOR DUCT	10			
VENTILATOR DUCT : Removal and Installation	10			
SIDE VENTILATOR DUCT	10			
SIDE VENTILATOR DUCT : Removal and Installation	10			
FRONT DEFROSTER NOZZLE	10			
FRONT DEFROSTER NOZZLE : Removal and Installation	10			
SIDE DEFROSTER NOZZLE	11			
SIDE DEFROSTER NOZZLE : Removal and Installation	11			
FOOT GRILLE	11			
FOOT GRILLE : Removal and Installation	11			
FOOT DUCT	11			
FOOT DUCT : Removal and Installation	11			
BLOWER UNIT	13			
Exploded View	13			
BLOWER UNIT	14			
BLOWER UNIT : Removal and Installation	14			
BLOWER MOTOR	15			
BLOWER MOTOR : Removal and Installation	15			
IN-CABIN MICROFILTER	16			
Exploded View	16			

VTL

Removal and Installation	16	Replacement	16
--------------------------------	----	-------------------	----

VENTILATION SYSTEM

< SYSTEM DESCRIPTION >

SYSTEM DESCRIPTION

VENTILATION SYSTEM

System Description

INFOID:000000011737214

OUTLINE

Ventilation system is controlled by A/C auto amp. For details of automatic air conditioner system, refer to [HAC-15. "System Description"](#) (WITHOUT 7 INCH DISPLAY) or [HAC-105. "System Description"](#) (WITH 7 INCH DISPLAY).

AIR FLOW

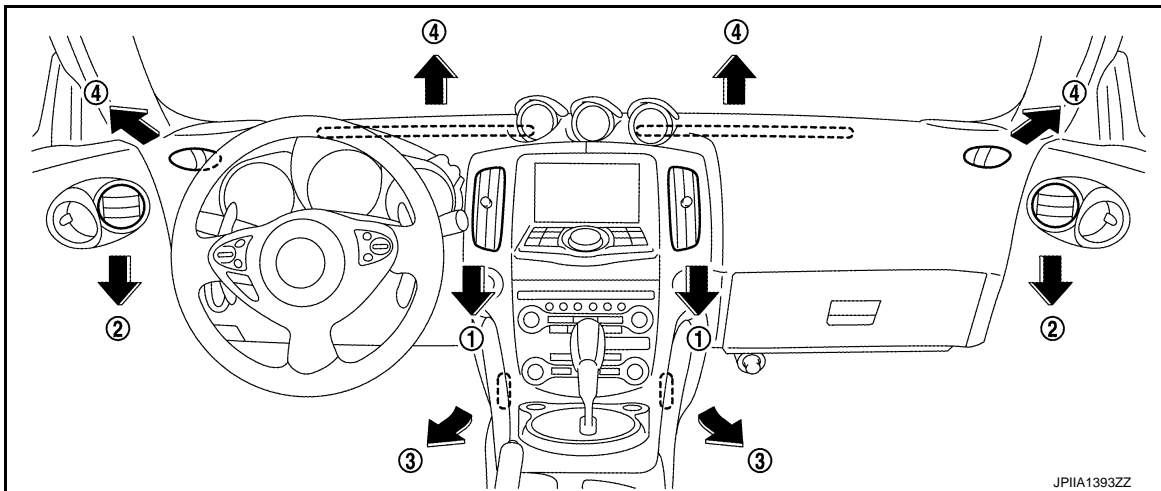

JPIIA1393ZZ

x: Applicable

MODE/DEF position indication	AIR OUTLET			
	Ventilator (1)	Ventilator (2)	Foot (3)	Defroster (4)
	x	x	—	—
	x	x	x	—
	x	x	x	x
	x	x	x	x
	—	—	—	x

A
B
C
D
E
F
G
H
J
K
L
M
N
O
P

VTL

PRECAUTIONS

< PRECAUTION >

PRECAUTION

PRECAUTIONS

FOR USA AND CANADA

FOR USA AND CANADA : Precaution for Supplemental Restraint System (SRS) "AIR BAG" and "SEAT BELT PRE-TENSIONER"

INFOID:000000011737215

The Supplemental Restraint System such as "AIR BAG" and "SEAT BELT PRE-TENSIONER", used along with a front seat belt, helps to reduce the risk or severity of injury to the driver and front passenger for certain types of collision. This system includes seat belt switch inputs and dual stage front air bag modules. The SRS system uses the seat belt switches to determine the front air bag deployment, and may only deploy one front air bag, depending on the severity of a collision and whether the front occupants are belted or unbelted. Information necessary to service the system safely is included in the "SRS AIR BAG" and "SEAT BELT" of this Service Manual.

WARNING:

Always observe the following items for preventing accidental activation.

- To avoid rendering the SRS inoperative, which could increase the risk of personal injury or death in the event of a collision that would result in air bag inflation, all maintenance must be performed by an authorized NISSAN/INFINITI dealer.
- Improper maintenance, including incorrect removal and installation of the SRS, can lead to personal injury caused by unintentional activation of the system. For removal of Spiral Cable and Air Bag Module, see "SRS AIR BAG".
- Never use electrical test equipment on any circuit related to the SRS unless instructed to in this Service Manual. SRS wiring harnesses can be identified by yellow and/or orange harnesses or harness connectors.

PRECAUTIONS WHEN USING POWER TOOLS (AIR OR ELECTRIC) AND HAMMERS

WARNING:

Always observe the following items for preventing accidental activation.

- When working near the Air Bag Diagnosis Sensor Unit or other Air Bag System sensors with the ignition ON or engine running, never use air or electric power tools or strike near the sensor(s) with a hammer. Heavy vibration could activate the sensor(s) and deploy the air bag(s), possibly causing serious injury.
- When using air or electric power tools or hammers, always switch the ignition OFF, disconnect the battery, and wait at least 3 minutes before performing any service.

FOR USA AND CANADA : Precaution for Battery Service

INFOID:000000011737216

Before disconnecting the battery, lower both the driver and passenger windows. This will prevent any interference between the window edge and the vehicle when the door is opened/closed. During normal operation, the window slightly raises and lowers automatically to prevent any window to vehicle interference. The automatic window function will not work with the battery disconnected.

FOR USA AND CANADA : Precaution for Procedure without Cowl Top Cover

INFOID:000000011737217

When performing the procedure after removing cowl top cover, cover the lower end of windshield with urethane, etc to prevent damage to windshield.

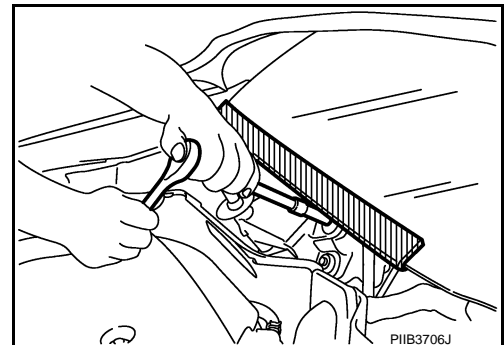

PRECAUTIONS

< PRECAUTION >

FOR USA AND CANADA : Precautions for Removing Battery Terminal

INFOID:000000011737218

- When removing the 12V battery terminal, turn OFF the ignition switch and wait at least 30 seconds.

NOTE:

ECU may be active for several tens of seconds after the ignition switch is turned OFF. If the battery terminal is removed before ECU stops, then a DTC detection error or ECU data corruption may occur.

- For vehicles with the 2-batteries, be sure to connect the main battery and the sub battery before turning ON the ignition switch.

NOTE:

If the ignition switch is turned ON with any one of the terminals of main battery and sub battery disconnected, then DTC may be detected.

- After installing the 12V battery, always check "Self Diagnosis Result" of all ECUs and erase DTC.

NOTE:

The removal of 12V battery may cause a DTC detection error.

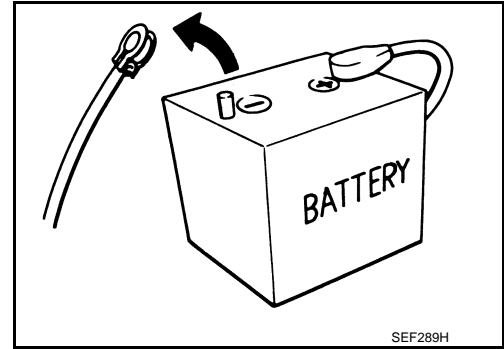

FOR MEXICO

FOR MEXICO : Precaution for Supplemental Restraint System (SRS) "AIR BAG" and "SEAT BELT PRE-TENSIONER"

INFOID:000000011737219

The Supplemental Restraint System such as "AIR BAG" and "SEAT BELT PRE-TENSIONER", used along with a front seat belt, helps to reduce the risk or severity of injury to the driver and front passenger for certain types of collision. Information necessary to service the system safely is included in the "SRS AIR BAG" and "SEAT BELT" of this Service Manual.

WARNING:

Always observe the following items for preventing accidental activation.

- To avoid rendering the SRS inoperative, which could increase the risk of personal injury or death in the event of a collision that would result in air bag inflation, all maintenance must be performed by an authorized NISSAN/INFINITI dealer.
- Improper maintenance, including incorrect removal and installation of the SRS, can lead to personal injury caused by unintentional activation of the system. For removal of Spiral Cable and Air Bag Module, see "SRS AIR BAG".
- Never use electrical test equipment on any circuit related to the SRS unless instructed to in this Service Manual. SRS wiring harnesses can be identified by yellow and/or orange harnesses or harness connectors.

PRECAUTIONS WHEN USING POWER TOOLS (AIR OR ELECTRIC) AND HAMMERS

WARNING:

Always observe the following items for preventing accidental activation.

- When working near the Air Bag Diagnosis Sensor Unit or other Air Bag System sensors with the ignition ON or engine running, never use air or electric power tools or strike near the sensor(s) with a hammer. Heavy vibration could activate the sensor(s) and deploy the air bag(s), possibly causing serious injury.
- When using air or electric power tools or hammers, always switch the ignition OFF, disconnect the battery, and wait at least 3 minutes before performing any service.

FOR MEXICO : Precaution for Battery Service

INFOID:000000011737220

Before disconnecting the battery, lower both the driver and passenger windows. This will prevent any interference between the window edge and the vehicle when the door is opened/closed. During normal operation, the window slightly raises and lowers automatically to prevent any window to vehicle interference. The automatic window function will not work with the battery disconnected.

A
B
C
D
E
F
G
H
I
J
K
L
M
N
O
P

VTL

PRECAUTIONS

< PRECAUTION >

FOR MEXICO : Precaution for Procedure without Cowl Top Cover

INFOID:000000011737221

When performing the procedure after removing cowl top cover, cover the lower end of windshield with urethane, etc to prevent damage to windshield.

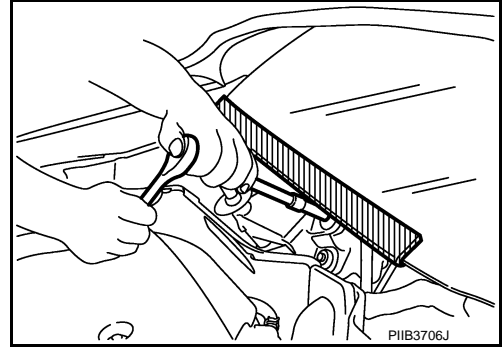

FOR MEXICO : Precautions for Removing Battery Terminal

INFOID:000000011737222

- When removing the 12V battery terminal, turn OFF the ignition switch and wait at least 30 seconds.

NOTE:

ECU may be active for several tens of seconds after the ignition switch is turned OFF. If the battery terminal is removed before ECU stops, then a DTC detection error or ECU data corruption may occur.

- For vehicles with the 2-batteries, be sure to connect the main battery and the sub battery before turning ON the ignition switch.

NOTE:

If the ignition switch is turned ON with any one of the terminals of main battery and sub battery disconnected, then DTC may be detected.

- After installing the 12V battery, always check "Self Diagnosis Result" of all ECUs and erase DTC.

NOTE:

The removal of 12V battery may cause a DTC detection error.

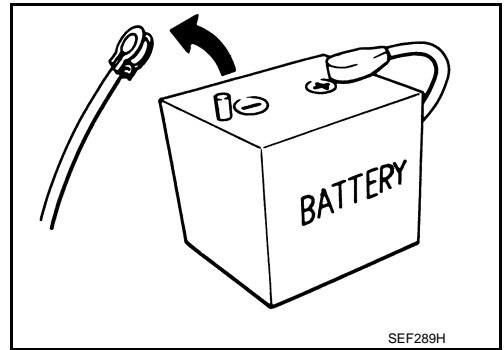

PREPARATION

< PREPARATION >

PREPARATION

PREPARATION

Commercial Service Tool

INFOID:000000011737223

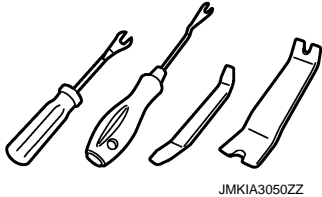
Tool name	Description
Remover tool  JMKIA3050ZZ	Remove clips, pawls and metal clips

A

B

C

D

E

F

G

H

VTL

J

K

L

M

N

O

P

DUCT AND GRILLE

< REMOVAL AND INSTALLATION >

REMOVAL AND INSTALLATION

DUCT AND GRILLE

Exploded View

INFOID:000000011737224

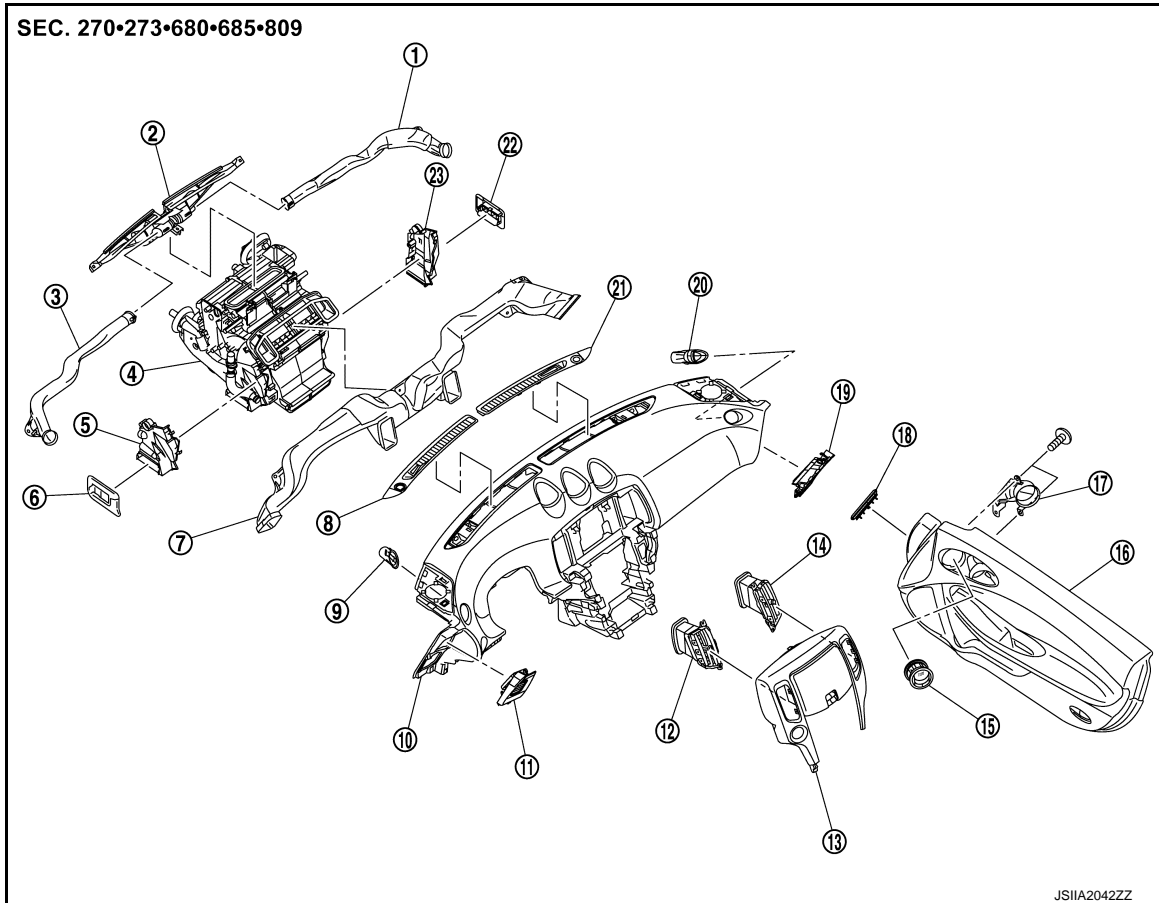

- | | | |
|-----------------------------------|---------------------------------|---------------------------------|
| 1. Side defroster nozzle RH | 2. Front defroster nozzle | 3. Side defroster nozzle LH |
| 4. Heater & cooling unit assembly | 5. Foot duct LH | 6. Foot grille LH |
| 7. Ventilator duct | 8. Front defroster grille LH | 9. Side defroster grille LH |
| 10. Instrument panel assembly | 11. Instrument side finisher LH | 12. Center ventilator grille LH |
| 13. Cluster lid C | 14. Center ventilator grille RH | 15. Side ventilator grille RH |
| 16. Door finisher RH | 17. Side ventilator duct RH | 18. Seal |
| 19. Instrument side finisher RH | 20. Side defroster grille RH | 21. Front defroster grille RH |
| 22. Foot grille RH | 23. Foot duct RH | |

CENTER VENTILATOR GRILLE

CENTER VENTILATOR GRILLE : Removal and Installation

INFOID:000000011737225

REMOVAL

1. Remove cluster lid C. Refer to [IP-13. "Exploded View"](#).

DUCT AND GRILLE

< REMOVAL AND INSTALLATION >

2. Remove fixing screws (A), and then remove center ventilator grille (1).

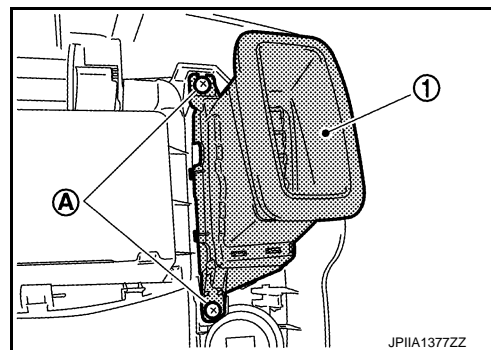

INSTALLATION

Install in the reverse order of removal.

SIDE VENTILATOR GRILLE

SIDE VENTILATOR GRILLE : Removal and Installation

INFOID:000000011737226

REMOVAL

1. Remove side ventilator duct. Refer to [VTL-8. "Exploded View"](#).
2. Disengage fixing pawls, and then remove side ventilator grille (1).

 : Pawl

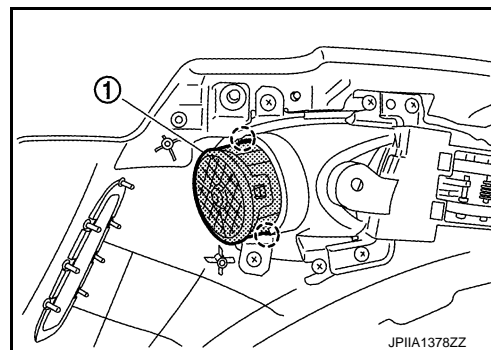

INSTALLATION

Install in the reverse order of removal.

FRONT DEFROSTER GRILLE

FRONT DEFROSTER GRILLE : Removal and Installation

INFOID:000000011737227

REMOVAL

1. Remove front defroster grilles (1), using a remover tool (A).

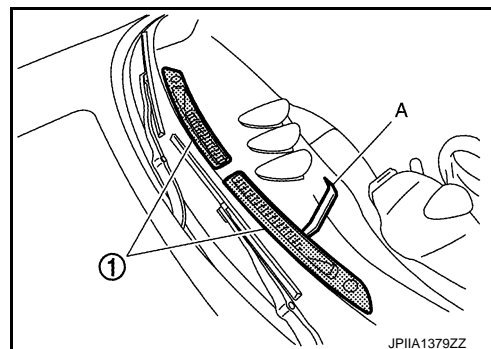

2. Remove sensors from front defroster grilles.

INSTALLATION

Install in the reverse order of removal.

SIDE DEFROSTER GRILLE

DUCT AND GRILLE

< REMOVAL AND INSTALLATION >

SIDE DEFROSTER GRILLE : Removal and Installation

INFOID:000000011737228

REMOVAL

Remove side defroster grille from instrument panel assembly.

INSTALLATION

Install in the reverse order of removal.

VENTILATOR DUCT

VENTILATOR DUCT : Removal and Installation

INFOID:000000011737229

REMOVAL

1. Remove instrument panel assembly. Refer to [IP-13, "Exploded View"](#).
2. Remove front defroster nozzle. Refer to [VTL-8, "Exploded View"](#).
3. Remove fixing clips (A), and then remove ventilator duct (1).

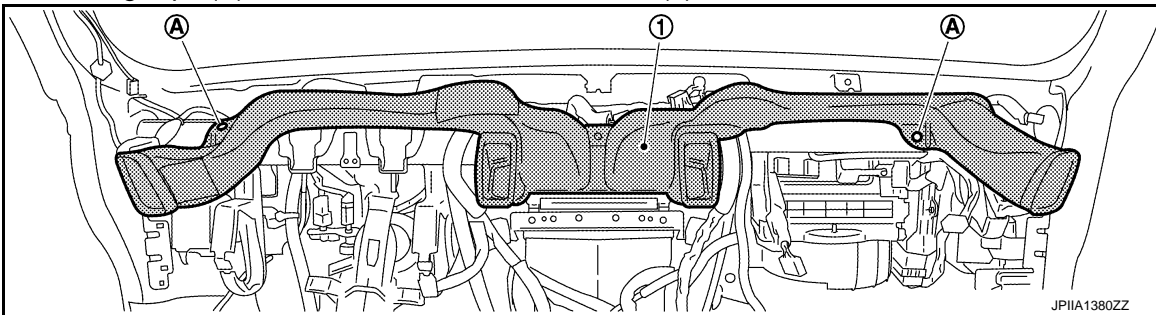

INSTALLATION

Install in the reverse order of removal.

SIDE VENTILATOR DUCT

SIDE VENTILATOR DUCT : Removal and Installation

INFOID:000000011737230

REMOVAL

1. Remove door finisher. Refer to [INT-15, "Exploded View"](#) (coupe models) or [INT-47, "Exploded View"](#) (roadster models).
2. Remove fixing screws (A), and then remove side ventilator duct (1).

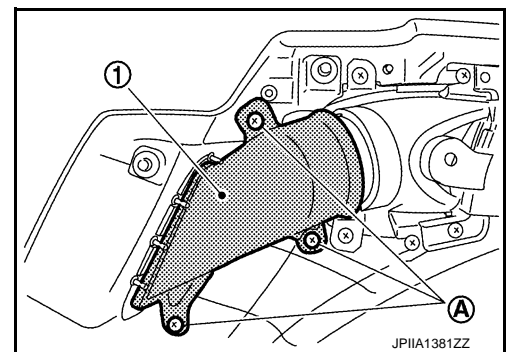

INSTALLATION

Install in the reverse order of removal.

FRONT DEFROSTER NOZZLE

FRONT DEFROSTER NOZZLE : Removal and Installation

INFOID:000000011737231

REMOVAL

1. Remove side defroster nozzles. Refer to [VTL-8, "Exploded View"](#).

DUCT AND GRILLE

< REMOVAL AND INSTALLATION >

2. Remove fixing screw (A), and then remove front defroster nozzle (1).

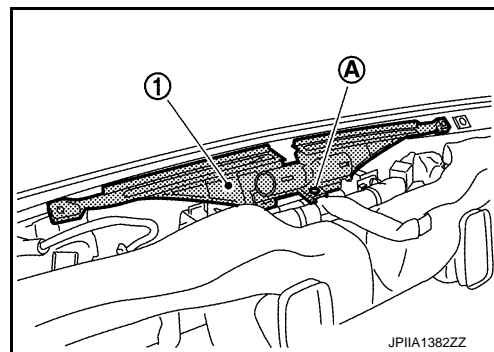

INSTALLATION

Install in the reverse order of removal.

SIDE DEFROSTER NOZZLE

SIDE DEFROSTER NOZZLE : Removal and Installation

INFOID:000000011737232

REMOVAL

1. Remove instrument panel assembly. Refer to [JP-13. "Exploded View"](#).
2. Remove fixing clip (A), and then remove side defroster nozzle (1).

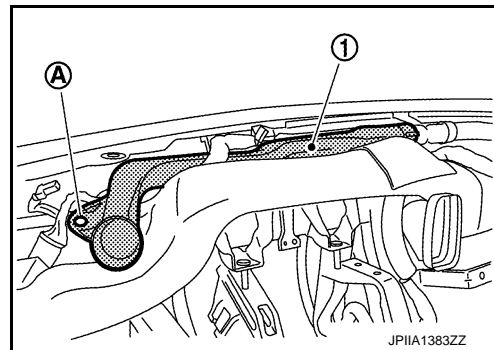

INSTALLATION

Install in the reverse order of removal.

FOOT GRILLE

FOOT GRILLE : Removal and Installation

INFOID:000000011737233

REMOVAL

Disengage fixing pawls, and then remove foot grille (1).

 : Pawl

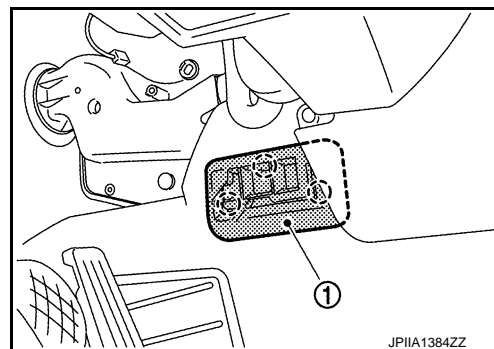

INSTALLATION

Install in the reverse order of removal.

FOOT DUCT

FOOT DUCT : Removal and Installation

INFOID:000000011737234

REMOVAL

A
B
C
D
E
F
G
H
VTL
J
K
L
M
N
O
P

DUCT AND GRILLE

< REMOVAL AND INSTALLATION >

Driver Side

1. Remove heater & cooling unit assembly. Refer to [HA-46, "Exploded View"](#).
2. Remove heater pipe cover. Refer to [HA-46, "Exploded View"](#).
3. Disengage fixing pawls, and then remove foot duct LH (1).

 : Pawl

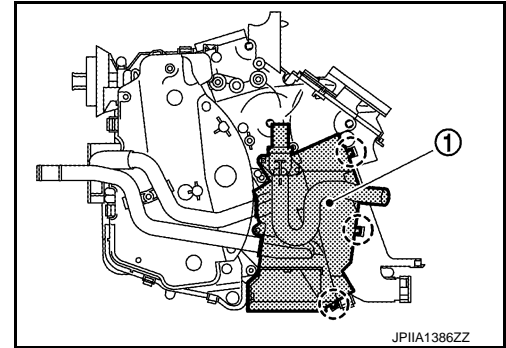

Passenger Side

1. Set the temperature at full cold.
CAUTION:
The angle may be out, when installing the air mix door motor to the air mix door, unless the above procedure is performed.
2. Disconnect the battery cable from the negative terminal.
3. Remove heater & cooling unit assembly. Refer to [HA-46, "Exploded View"](#).
4. Remove air mix door motor and mode door motor. Refer to the following.
 - Refer to [HAC-93, "Exploded View"](#). (WITHOUT 7 INCH DISPLAY)
 - Refer to [HAC-183, "Exploded View"](#). (WITH 7 INCH DISPLAY)
5. Remove evaporator cover. Refer to [HA-51, "Exploded View"](#).
6. Disengage fixing pawls, and then remove foot duct RH (1).

 : Pawl

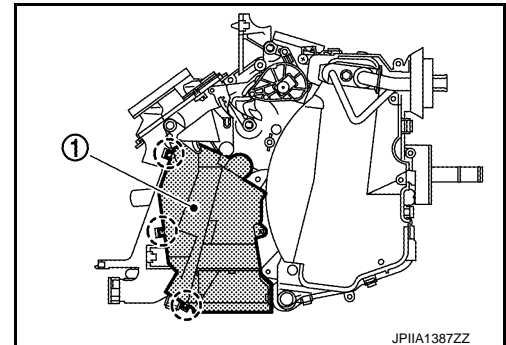

INSTALLATION

Install in the reverse order of removal.

BLOWER UNIT

< REMOVAL AND INSTALLATION >

BLOWER UNIT

Exploded View

INFOID:000000011737235

REMOVAL

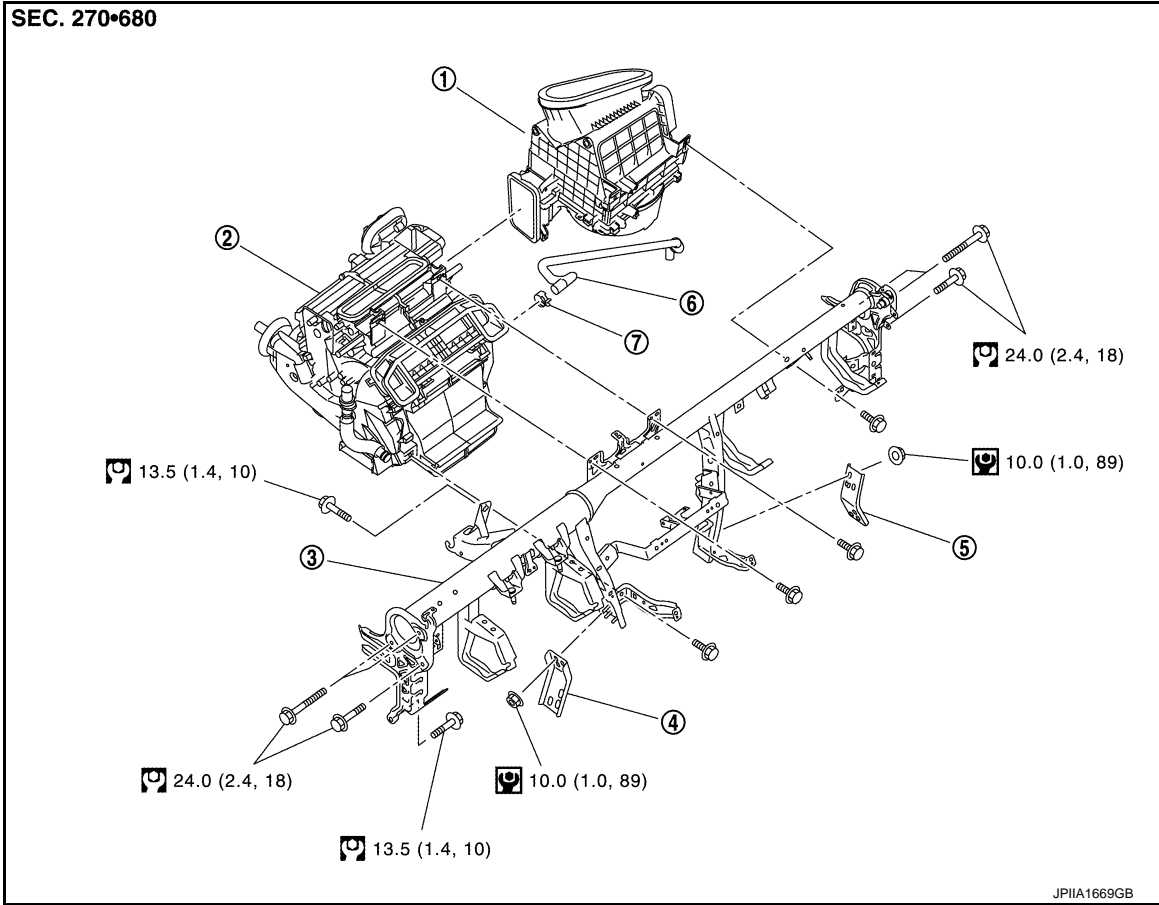

- | | | |
|-------------------------|-----------------------------------|--------------------|
| 1. Blower unit assembly | 2. Heater & cooling unit assembly | 3. Steering member |
| 4. Instrument stay LH | 5. Instrument stay RH | 6. Drain hose |
| 7. Clamp | | |

: N-m (kg-m, ft-lb)

: N-m (kg-m, in-lb)

DISASSEMBLY

A
B
C
D
E
F
G
H
VTL
J
K
L
M
N
O
P

BLOWER UNIT

< REMOVAL AND INSTALLATION >

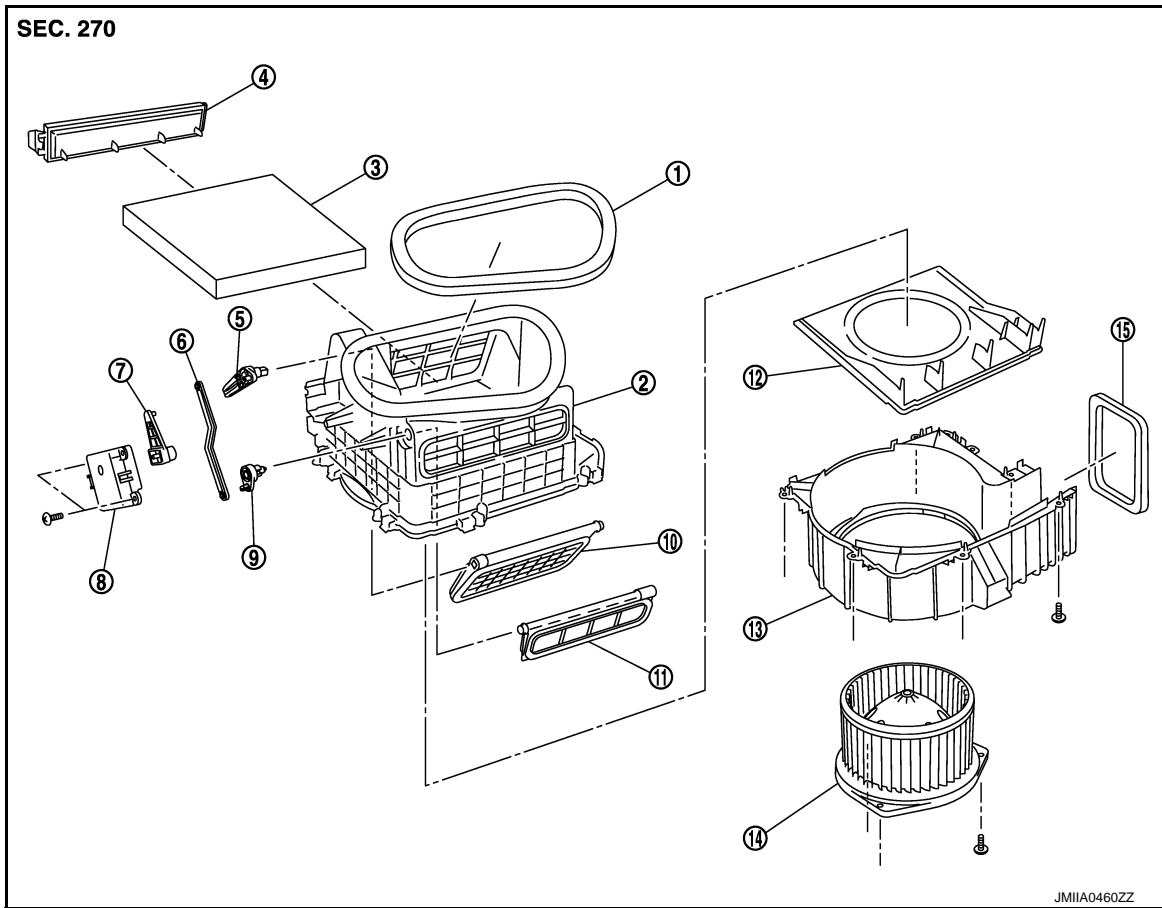

- | | | |
|------------------------|---------------------------|--|
| 1. Seal | 2. Intake upper case | 3. In-cabin microfilter
(Air conditioner filter)* |
| 4. Filter cover | 5. Intake door lever 1 | 6. Intake door link |
| 7. Intake door lever 2 | 8. Intake door motor | 9. Intake door lever 3 |
| 10. Intake door 2 | 11. Intake door 1 | 12. Intake bell mouth |
| 13. Intake lower case | 14. Blower motor assembly | 15. Seal |

*: Models for MEXICO only

BLOWER UNIT

BLOWER UNIT : Removal and Installation

INFOID:000000011737236

REMOVAL

1. Remove instrument lower panel RH. Refer to [IP-13, "Exploded View"](#).
2. Disconnect intake door motor connector.
3. Disconnect blower motor connector.
4. Remove mounting bolt (A) and fixing screws (B), and then remove blower unit assembly (1).

CAUTION:

Move blower unit assembly rightward, and remove locating pin (1 part) and joint. Then remove blower unit assembly downward.

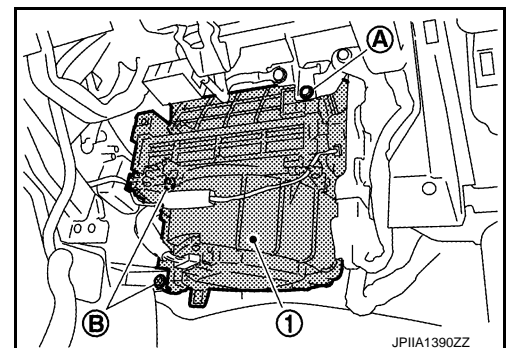

BLOWER UNIT

< REMOVAL AND INSTALLATION >

INSTALLATION

Note the following item, and then install in the reverse order of removal.

CAUTION:

Check locating pin (A) and joint (B) are securely inserted.

← : Vehicle front

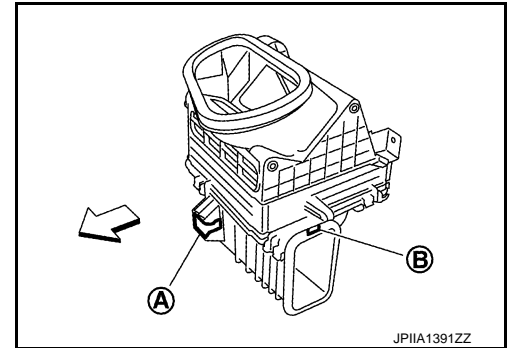

BLOWER MOTOR

BLOWER MOTOR : Removal and Installation

INFOID:000000011737237

REMOVAL

1. Disconnect blower motor connector.
2. Remove fixing screws (A), and then remove blower motor (1).

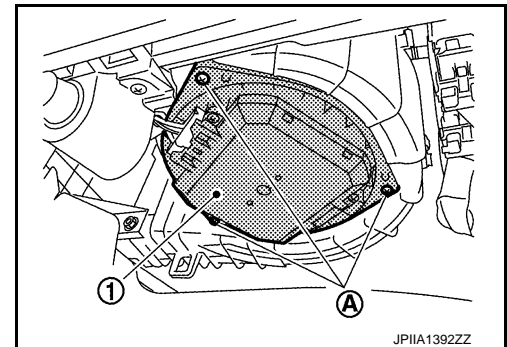

INSTALLATION

Install in the reverse order of removal.

A
B
C
D
E
F
G
H
VTL
J
K
L
M
N
O
P

IN-CABIN MICROFILTER

< REMOVAL AND INSTALLATION >

IN-CABIN MICROFILTER

Exploded View

INFOID:000000011737238

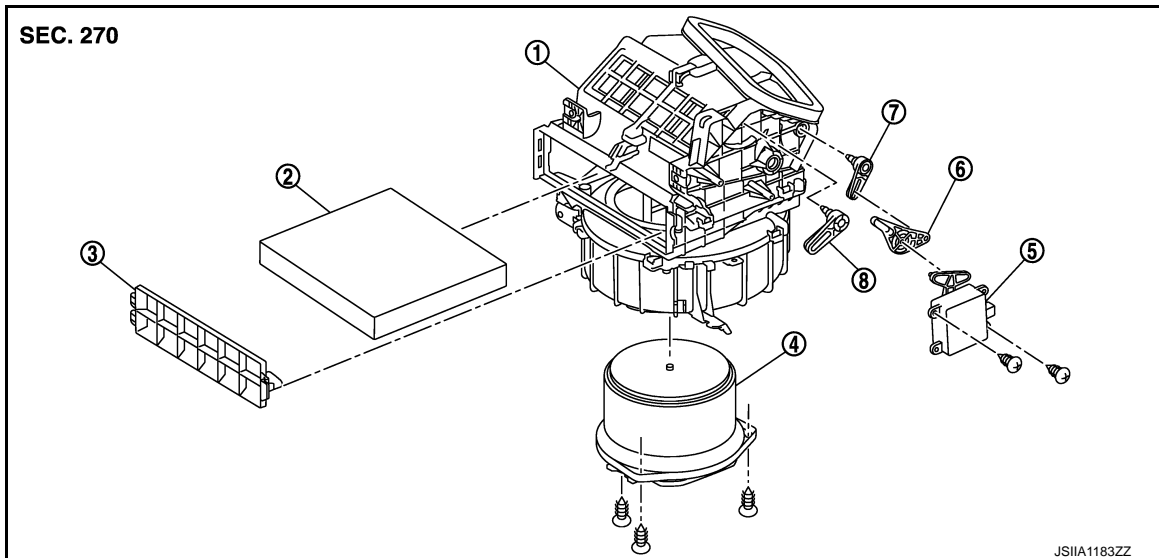

- | | | |
|--------------------------|--|---------------------|
| 1. Blower unit | 2. In-cabin microfilter
(Air conditioner filter)* | 3. Filter cover |
| 4. Blower motor assembly | 5. Intake door motor | 6. Intake door link |
| 7. Intake door lever 1 | 8. Intake door lever 2 | |

*: Models for MEXICO only

Removal and Installation

INFOID:000000011737239

REMOVAL

1. Remove instrument lower panel RH. Refer to [IP-13, "Exploded View"](#).
2. Remove filter cover, and then remove in-cabin microfilter or air conditioner filter.

INSTALLATION

Note the following items, and then install in the reverse order of removal.

CAUTION:

- If the filter is deformed/damaged when removing, replace it with a new one. Deformed/damaged filter may deteriorate the duct collecting performance.
- When installing, handle the filter with extreme care to avoid deforming/damaging.

Replacement

INFOID:000000011737240

Replace in-cabin microfilter or air conditioner filter. Refer to the following.

Models for NORTH AMERICA: Refer to [MA-10, "FOR NORTH AMERICA : Introduction of Periodic Maintenance"](#) (Regular Grade) or [MA-47, "FOR NORTH AMERICA : Introduction of Periodic Maintenance"](#) (NISMO Grade).

Models for MEXICO: Refer to [MA-13, "FOR MEXICO : Periodic Maintenance"](#).

Affix a caution label inside the glove box when replacing filter.