

SERVICE MANUAL

Datsun

MODEL 510 SERIES
CHASSIS and BODY



SECTION RA

REAR AXLE & REAR SUSPENSION

RA

REAR AXLE AND SUSPENSION - SEDAN	RA- 1
REAR AXLE -STATION WAGON	RA-12
REAR SUSPENSION -STATION WAGON	RA-15
SERVICE DATA AND SPECIFICATONS	RA-18

REAR AXLE & REAR SUSPENSION

REAR AXLE AND SUSPENSION-SEDAN

CONTENTS

DESCRIPTION	RA- 2	Inspection	RA- 7
REAR AXLE AND SUSPENSION ASSEMBLY	RA- 2	Installation	RA- 7
Removal	RA- 2	REAR AXLE SHAFT, WHEEL BEARINGS AND SEALS	RA- 7
Inspection and repair	RA- 3	Removal and disassembly	RA- 7
Installation	RA- 4	Inspection	RA- 7
SUSPENSION COIL SPRING	RA- 4	Assembly and installation	RA- 8
Removal	RA- 4	Wheel bearing adjustment	RA- 9
Inspection and repair	RA- 5	DRIVE SHAFT	RA- 9
Installation	RA- 5	Removal	RA-10
SHOCK ABSORBER	RA- 5	Disassembly	RA-10
Removal	RA- 5	Inspection	RA-10
Inspection	RA- 5	Assembly	RA-10
Installation	RA- 5	TROUBLE DIAGNOSES AND CORRECTIONS	RA-11
REAR SUSPENSION ARM	RA- 6		
Removal	RA- 6		

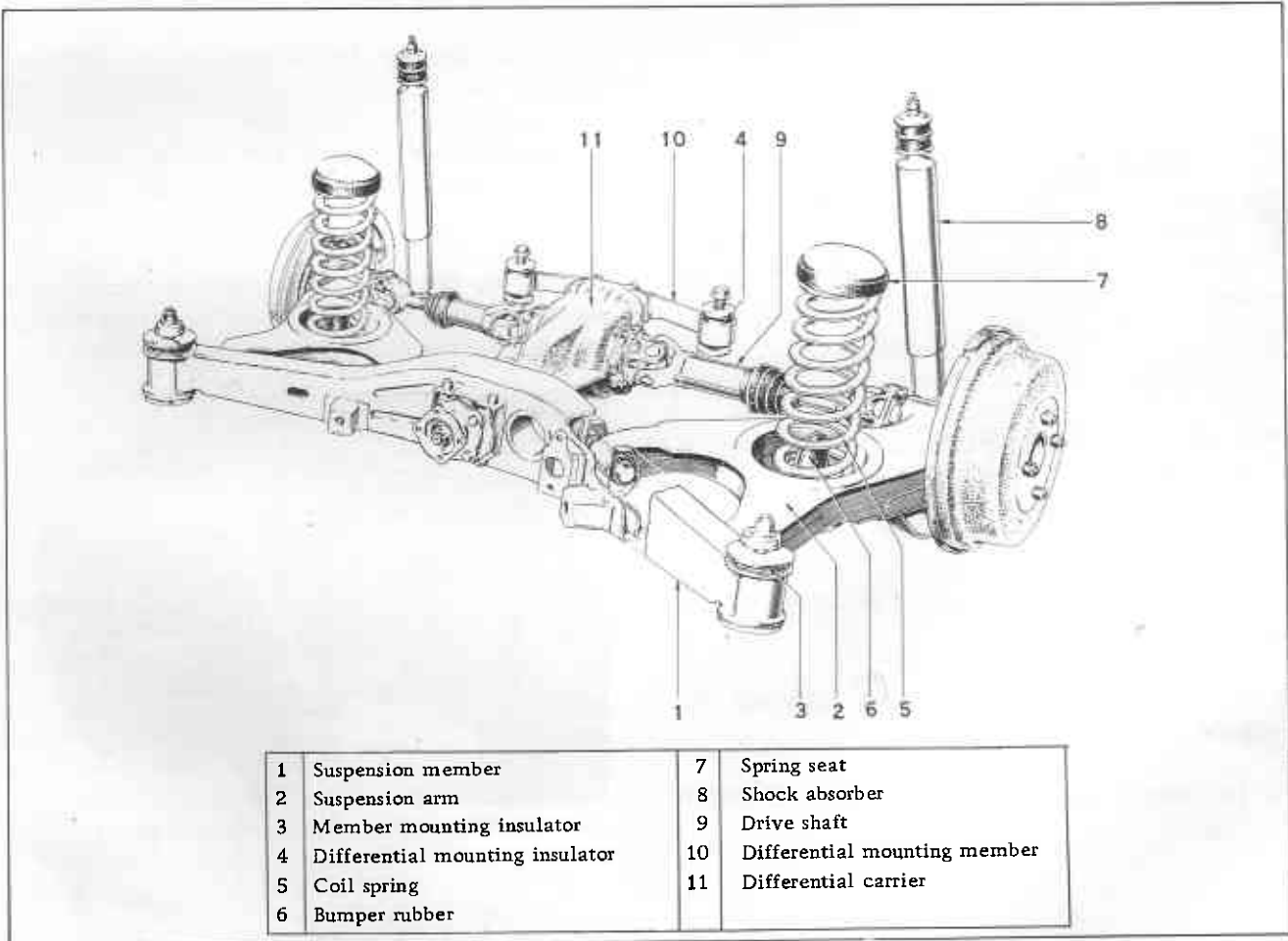

Fig. RA-1 Rear axle and suspension

CHASSIS

DESCRIPTION

The fully independent rear suspension is of the semi-trailing arm design utilizing a robust suspension member, suspension arms, coil springs and telescopic hydraulic double acting shock absorbers. The final drive unit is mounted to the suspension member body, by means of four bolts and is attached to the body structure through two rubber insulators.

In addition to performing its primary function the drive unit is an important part of the total rigidity of the suspension system.

Each trailing arm pivots on two mountings attached to the suspension member through rubber insulators.

The rear wheel bearing housing and shock-absorber lower bracket is welded to the trailing end of the suspension arm.

Coil springs are mounted between the suspension arms and body. Bound rubbers are fitted to the suspension member in the center of the coil spring.

Drive shaft is of the ball spline type with universal joints at both ends.

Two ball bearings support the axle shaft.

It is not necessary to check the lubrication of the wheel bearings and no adjustment is required.

However, when fitting new wheel bearings it is necessary to use the proper lubricant in the correct quantity.

REAR AXLE & SUSPENSION ASSEMBLY

Removal

1. Jack up the rear of the car and support it on stands.
2. Remove the wheel nuts and take off the wheels.
3. Disconnect the hand brake linkage and return spring.

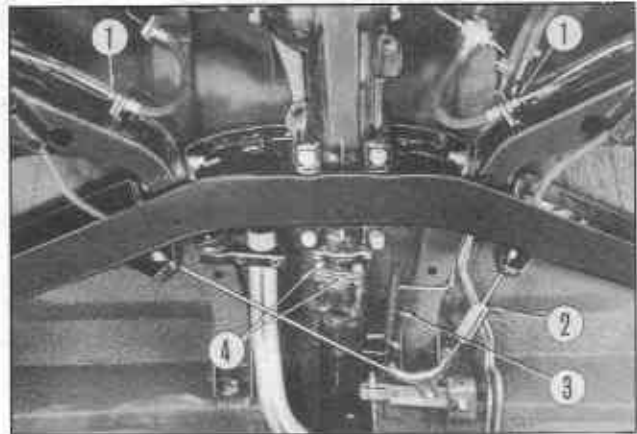

- | | |
|---|--|
| 1 | Brake tube connector |
| 2 | Hand brake rear cable adjuster |
| 3 | Return spring |
| 4 | Propeller shaft to differential fixing bolts |

Fig. RA-2 Rear suspension removal points

4. Remove the exhaust tail pipe and muffler.
5. Disconnect the brake hose from the brake tube.
6. Remove four bolts fixing the propeller shaft to the differential and withdraw the propeller shaft.
7. Jack up the suspension arm and remove the shock absorber from its lower mounting bracket taking care not to lose the rubber bushings.



Fig. RA-3 Shock absorber lower bracket

REAR AXLE & REAR SUSPENSION

8. Support the suspension member center and drive unit with a transmission jack. Remove two nuts mounting suspension member to the body.

9. Remove the two nuts attaching the differential mounting member to the body.

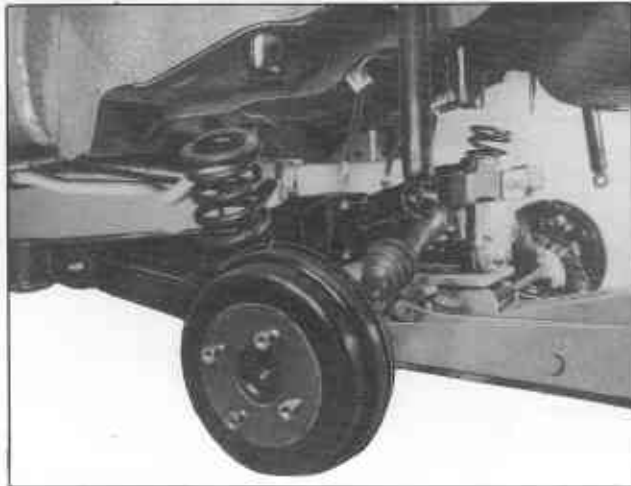

Fig. RA-4 Removing rear axle and suspension assembly

10. Gently drop down the suspension assembly from the body by carefully lowering the jack. Support the suspension so that it does not tilt and fall off the jack.

Inspection and repair

When the rear suspension has been removed examine all parts for wear or damage. Particular attention should be given to the bushing in the suspension arms and bound bumper rubbers. Also check the condition of the spring rubber insulators in the suspension member and drive unit mounting member.

Any of these components, if worn, can result in the transmission of noise and vibration from the road or the differential unit to the interior of the car.

Yielding of the rubber insulators can be easily checked by measuring the 'A' length indicated in Figure RA-6. Replace rubber insulators using rear suspension member insulator replacer special tool ST49170000.

Insulators should be replaced if the 'A' dimension is less than 5 mm (0.197 in.).

Note: The measurement of the 'A' dimension must be taken before the suspension system is removed from the car. The car must be in an unladen state.

If any load bearing component of the suspension, such as the suspension arms, is in anyway damaged it is most important that they be replaced with new parts.

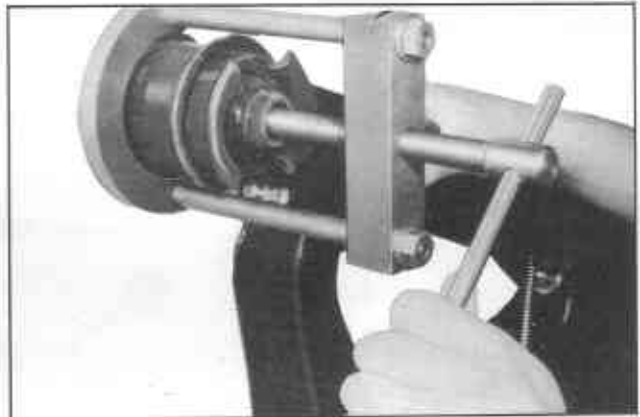

Fig. RA-5 Removing insulator from suspension member

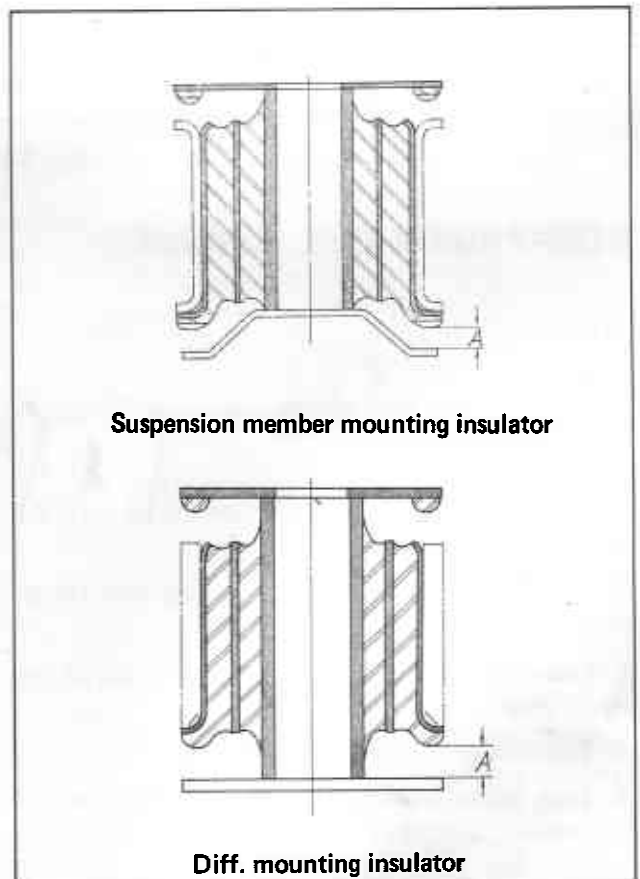

Fig. RA-6 Mounting insulators

CHASSIS

Installation

Installation of the suspension assembly is the reversal of the procedure given for removal noting the following points.

1. Ensure the suspension member and drive unit mounting member are correctly lined up.
2. Fit the washers and nuts correctly. Tighten the suspension member mounting nuts to a torque of 10 kg-m (72.3 ft-lb).

Tighten the differential mounting member nuts to a torque of 8.5 kg-m (61.6 ft-lb).

3. Tighten shock absorber lower end fixing nut to a torque of 2.3 kg-m (16.6 ft-lb).
4. The rubber insulators should be correctly lined up as shown in Figure RA-7 and inserted from the underside of the member.

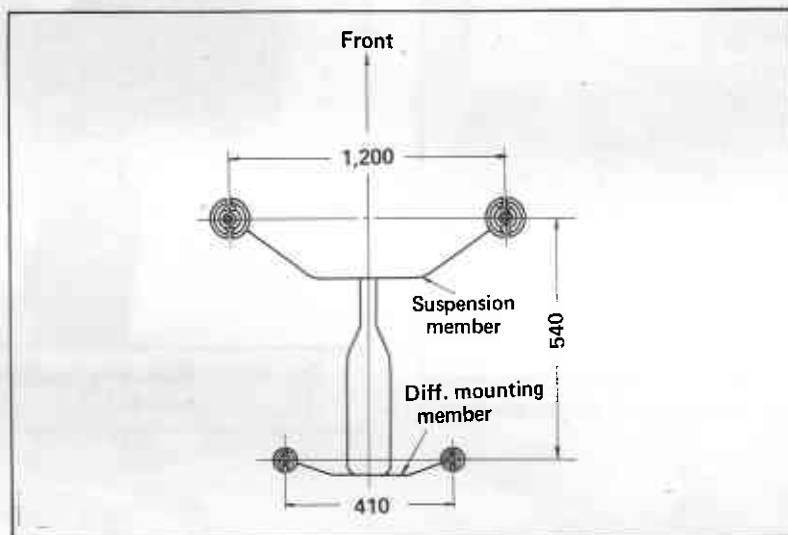

Fig. RA-7 Insulator

SUSPENSION COIL SPRING

Removal

1. Jack up the rear of the vehicle and support it on stands.
2. Remove the wheel nuts and take off the wheels.
3. Disconnect the hand brake linkage and return spring.
4. Remove the drive shaft flange nuts on the wheel side.
5. Remove nuts securing bound rubbers.
6. Jack under the suspension arm and remove the shock absorber from its lower mounting. Lower the jack gently and remove the coil spring, spring seat and bound rubber.

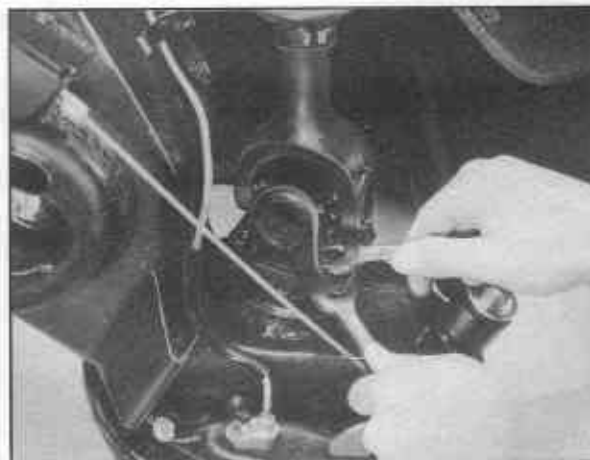

Fig. RA-8 Removing drive shaft flange nuts

REAR AXLE & REAR SUSPENSION

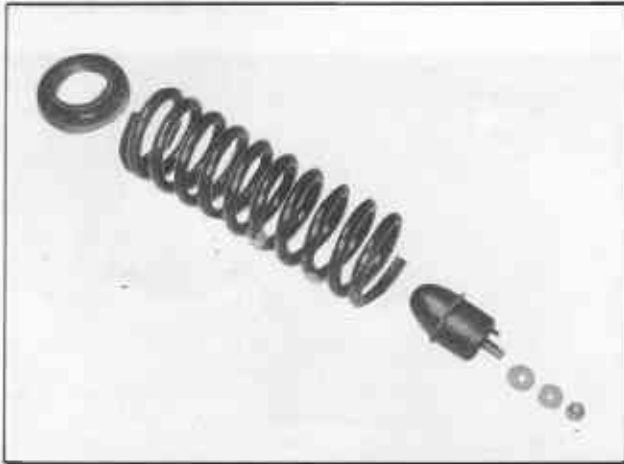

Fig. RA-9 Coil spring

Inspection and repair

1. Check coil spring for yield, deformation or cracks.
2. Test spring and compare with the specification given in **Service Data and Specifications**.
3. Check all rubber parts for wear, damage and deformation. Replace if necessary.

Installation

Installation of the coil spring is the reversal of the procedure given for removal noting the following points.

Ensure that the coil spring is correctly in position (flat face of the spring is top).

SHOCK ABSORBER

Removal

1. Open the trunk and remove the trunk finisher assembly.
2. Remove the double nuts which fasten the upper end of the rear shock absorber to the body.

3. Remove the shock absorber from its lower mounting bracket on the axle housing.

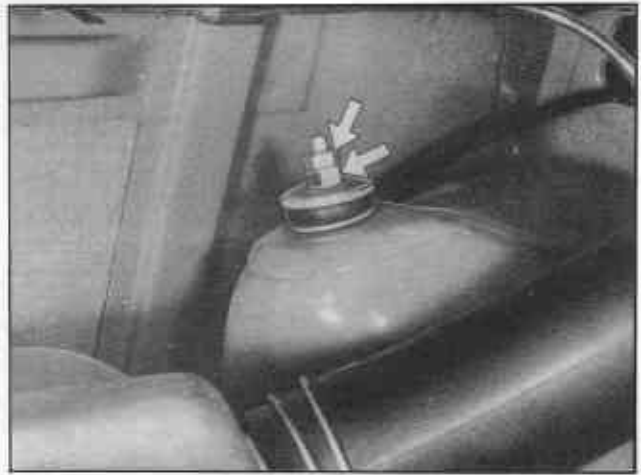

Fig. RA-10 Installation of rear shock absorber upper end

Inspection

1. Test the shock absorber and compare with the specification given in **Service Data and Specifications**. Replace if necessary.
2. Check for oil leakage cracks and the shaft for straightness.
3. Inspect the rubber bushings for damage, cracks and deformation. Replace the parts, if necessary.

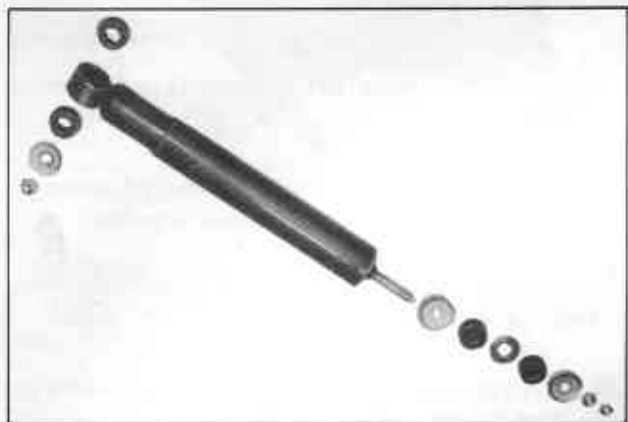

Fig. RA-11 Rear shock absorber

Installation

Installation of the shock absorber is the reversal of the procedure given for removal.

CHASSIS

REAR SUSPENSION ARM

The rear axle shaft housing and shock absorber lower mounting bracket are welded to the suspension arm.

Removal

1. Jack up the rear of the car and support it on stands.
2. Remove the wheel and brake drum.
3. Disconnect the drive shaft from the axle shaft.
4. Disconnect the hand brake cable from the balancing lever.

Remove the hand brake cable from the lever attached to the wheel cylinder.

5. Disconnect the brake hose from the brake tube by removing the lock spring and draw out through the connector.

Note: Plug the brake tube with a plastic cover or wooden peg to avoid spilling fluid during sequent work.

6. Remove the wheel bearing lock nut.
Remove the rear axle shaft, wheel bearings and oil seal.

7. Remove the rear brake assembly from the suspension arm.

8. Jack under the suspension arm and remove the shock absorber from its lower bracket.

9. Lower the jack gradually and remove the coil spring, spring seat and bound bumper rubber.

10. Remove the two bolts securing the suspension arm to the suspension member and remove the suspension arm.

11. Draw out the rubber bushings from the suspension arm using the rear suspension arm bush remover special tool ST49160000 as shown in Figure RA-14.

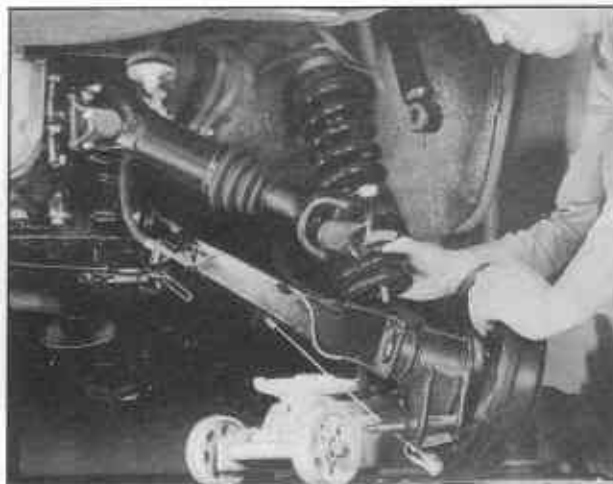

Fig. RA-12 Removing coil spring

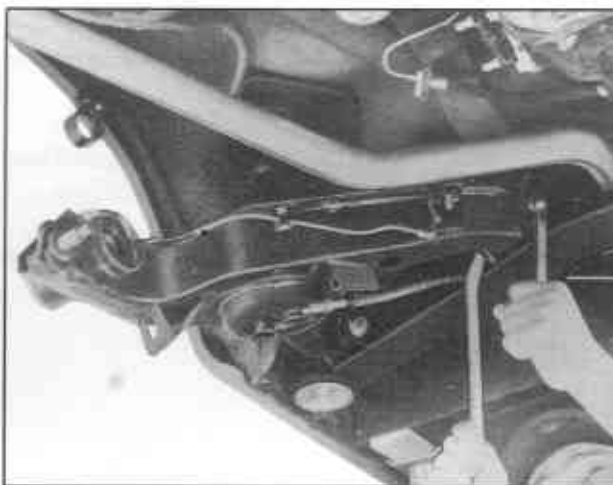

Fig. RA-13 Removing suspension arm

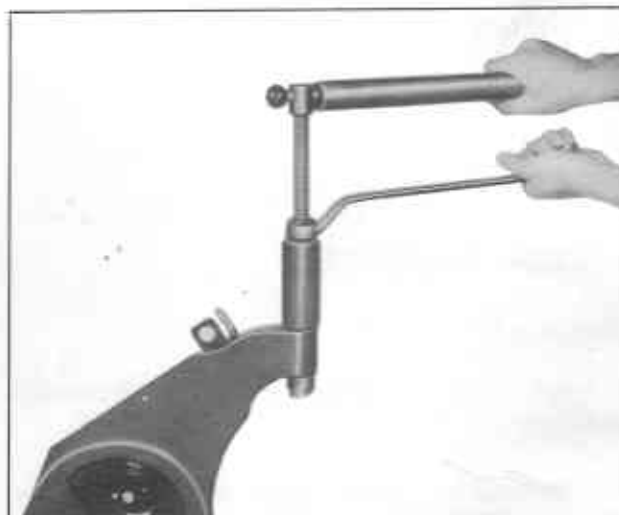

Fig. RA-14 Removing suspension arm rubber bush with special tool ST49160000

REAR AXLE & REAR SUSPENSION

Inspection

1. Examine the suspension arms to ensure they are not deformed or cracked.
2. Check the rubber bushings for wear, damage and separation. Replace if necessary.

Installation

Installation is the reversal of the procedure given for removal noting the following points.

1. When installing the suspension arm to the suspension member, the bolts should be tightened with the vehicle in the fully laden state.
2. Change the self locking nuts every overhaul.

REAR AXLE SHAFT, WHEEL BEARINGS AND SEALS

Removal and disassembly

1. Jack up the rear of the car and support on stands.
2. Remove the wheel and brake drum.
3. Disconnect the drive shaft from the axle shaft.

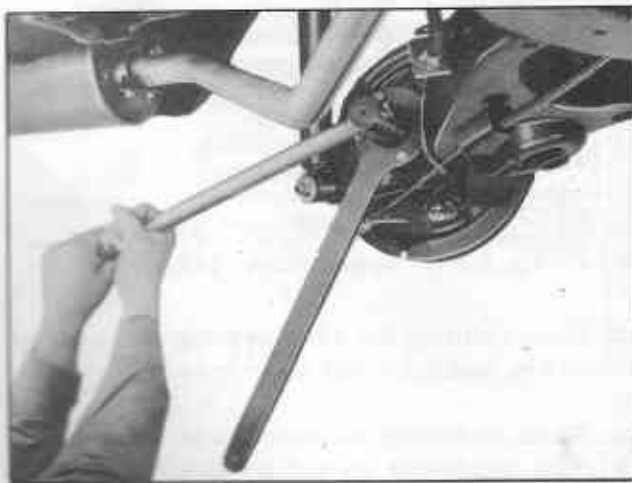

Fig. RA-15 Removal of wheel bearing lock nut

4. Remove the wheel bearing lock nut using axle shaft flange wrench (special tool ST49190000) to hold the companion flange as shown in Figure RA-15.

5. Draw out the axle shaft assembly using a sliding hammer (special tool ST46780000). Remove the rear axle companion flange.



Fig. RA-16 Removal of rear axle shaft

6. Remove the oil seal and inner bearing using rear axle shaft bearing drift (special tool ST49180000).



Fig. RA-17 Removing inner bearing using special tool ST49180000

7. Remove the grease catcher.
8. Withdraw the outer bearing using a standard bearing puller.

Note: Since the outer bearing will have to be pulled on the inner race the bearing should not be reused.

Inspection

Inspect the following parts for defects. If necessary replace or repair.

CHASSIS

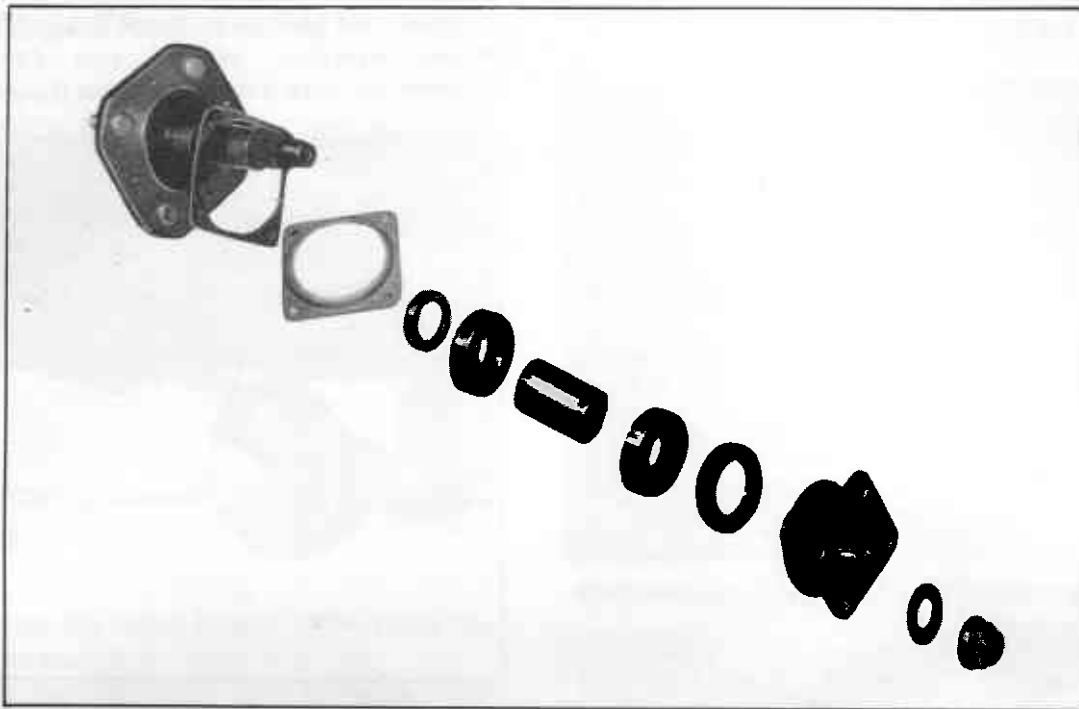

Fig. RA-18 Rear axle components

1. Check the axle shaft for straightness, cracks damage, wear and distortion.

Note: The axle shaft should not be heated to correct alignment.

2. Check the lip of the oil seal for damage, deformation and wear.

3. Check the bearing for excessive wear and damage. Replace if necessary.

Assembly and installation

Installation is the reversal of the procedure given for removal noting the following points.

1. Clean the wheel bearings, oil seal and inside of the axle shaft housing.

2. The wheel bearings are of the sealed type. When installing ensure that the sealed side of the outer bearing faces the wheel and that the sealed side of the inner bearing faces the differential (See Fig. RA-19).

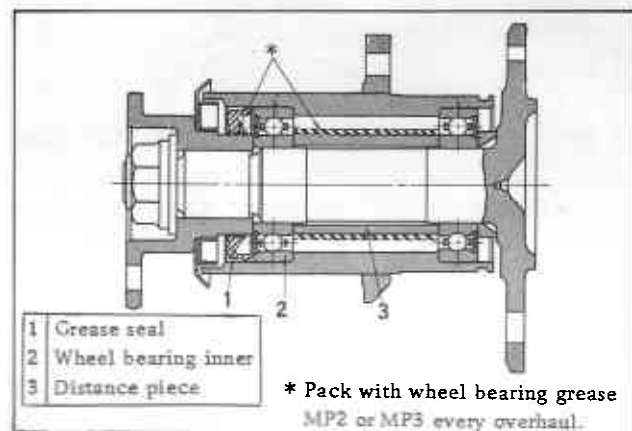

Fig. RA-19 Sectional view of rear axle

3. When refitting the wheel bearing the pressure should be applied to the inner race.

4. When replacing the suspension arm, measure the dimension L_1 and L_2 (See Fig. RA-20).

The length of the distance piece is 0.05 mm (0.0020 in.) less than the 'L' length of the housing. Example: if an axle housing was coded "B" you would select a "B" coded distance piece.

REAR AXLE & REAR SUSPENSION

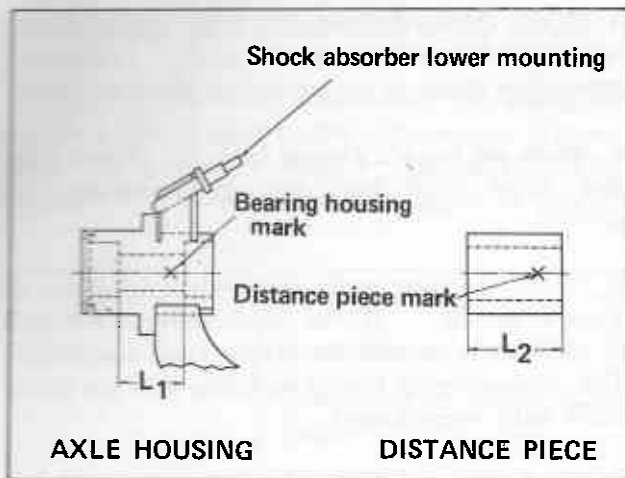

Fig. RA-20

Rear axle shaft housing mm (in.)		Rear wheel bearing distance piece mm (in.)	
Mark	L ₁ length	Mark	L ₂ length
A	59.05 ~ 59.15 (2.325 ~ 2.329)	A	59.02 ~ 59.08 (2.324 ~ 2.320)
B	58.95 ~ 59.05 (2.321 ~ 2.325)	B	58.72 ~ 58.98 (2.311 ~ 2.322)
C	58.85 ~ 58.95 (2.317 ~ 2.321)	C	58.82 ~ 58.88 (2.316 ~ 2.318)

5. Replace wheel bearings grease every 2 years or 50,000 km (30,000 mile).

Pack wheel bearings with MP2 or MP3 grease as shown Figure RA-19. Coat around the lip seal and into the wheel bearing.

6. Replace the wheel bearing nut after it has been used twice.

Wheel bearing adjustment

1. After tightening the nut to a torque of 25-33 kg-m (181-239 ft-lb) check the rear axle shaft end play. It should be 0-0.15 mm (0-0.006 in.) and should have a turning torque less than 4.5 kg-cm (64.5 in-oz).

If the correct end play or turning torque cannot be obtained, disassemble again and replace the distance piece.

DRIVE SHAFT

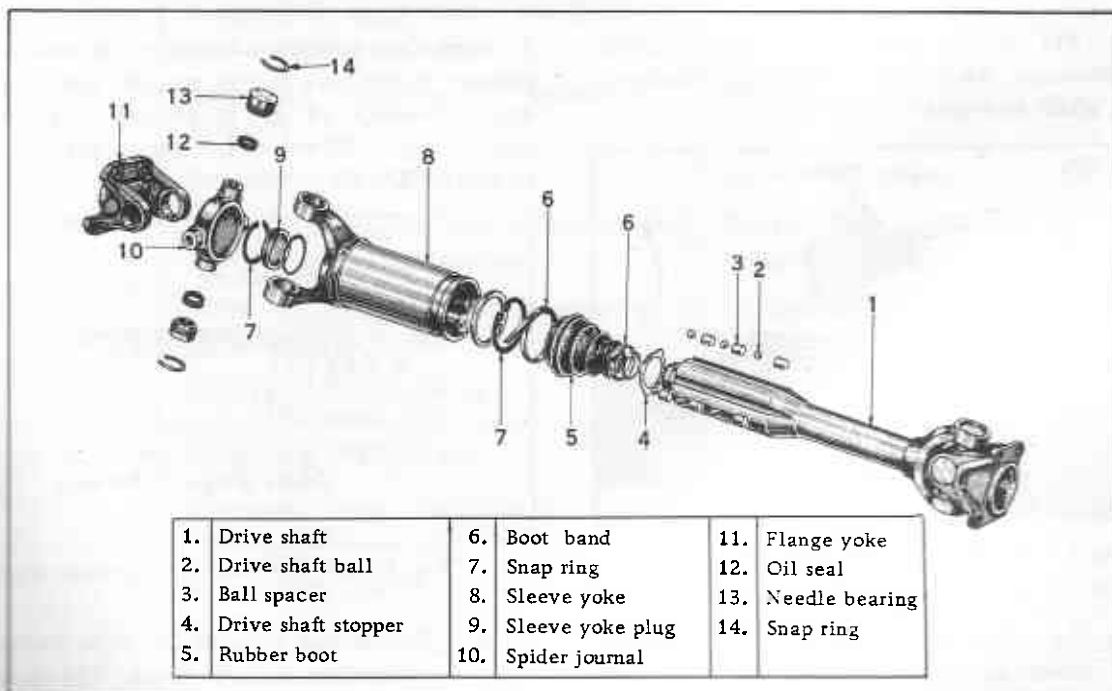

Fig. RA-21 Drive shaft

CHASSIS

Removal

1. Remove the drive shaft universal joint yoke flange bolts at both ends.

Note: During this operation care should be taken handling the drive shaft as it is easily damaged.

Disassembly

Disassembly should be done only to lubricate the ball spline. This will be required every 2 years or 50,000 km (30,000 mile).

1. Remove the universal joint spider located at the differential side. Refer to the section covering the propeller shaft.

2. Remove the snap ring which secures the sleeve yoke plug and remove the plug. Compress the drive shaft and remove the snap ring securing the stopper ④. Remove the stopper.

Disconnect the boot and split the drive shaft taking care not to lose the balls and spacers.

Inspection

1. Replace the boots and 'O' ring of the sleeve yoke plug, if damaged.

2. Check the drive shaft for straightness cracks, damage, wear and distortion. Replace the drive shaft assembly if necessary.

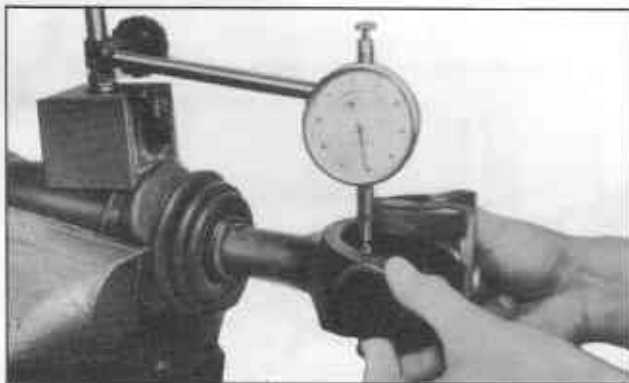

Fig. RA-22 Measuring play in drive shaft

3. Check the steel balls and sleeve yoke for damage, wear and distortion. Replace the drive shaft assembly if defective parts are found.

4. If any abnormal condition is found in the universal joints replace the joint. Following procedure given in the propeller shaft section.

5. Wash out the old grease from the sleeve yoke and drive shaft ball rolling groove and oil groove.

6. Check the play in the drive shaft as shown in Figure RA-22. If the play exceeds 0.1 mm (0.0039 in.) replace the drive shaft assembly. The measurement should be taken with the drive shaft fully compressed.

7. Check the radial play of the drive shaft and if excessive replace the drive shaft assembly.

Assembly

Assembly is the reversal of the procedure given for removal noting the following points.

1. Align the yokes and ensure that the steel balls and spacers are fitted in the correct sequence.

2. Adjust the axial play of the universal joint to within 0.02 mm (0.0008 in.) by selecting a suitable snap ring. Four thicknesses of snap rings are available.

3. Apply an adequate quantity of multipurpose grease to the ball rolling groove and oil groove, approximately 10 g, (0.35 oz). In addition apply 35 g (1.23 oz) of grease to the area shown in figure RA-23.

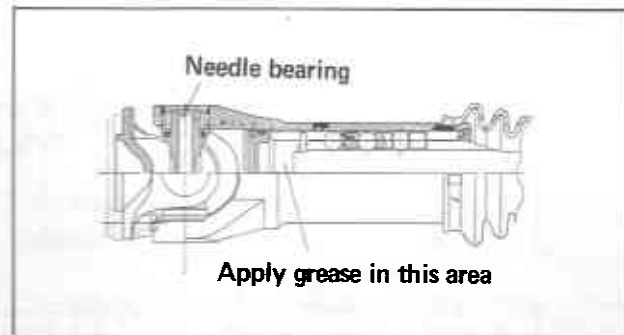

Fig. RA-23 Sectional view of drive shaft

Note: Component parts of the drive shaft are not available as separate items. Therefore, if any wear or damage exists in a certain part the drive shaft assembly will have to be replaced.

REAR AXLE & REAR SUSPENSION

TROUBLE DIAGNOSES AND CORRECTIONS

Noise in the rear suspension can easily be mistaken for a fault in the differential carrier or in the propeller shaft. Therefore, it is necessary to make a thorough check to deter-

mine if the suspension system is the cause of the problem. In the case of an oil leak first check if there is any damage of restriction in the breather.

Troubles	Possible causes	Remedies
Noise	<p>Loosening of wheel nuts.</p> <p>Loosening of one or more securing bolts.</p> <p>Lack of lubricating oil and grease.</p> <p>Defective shock absorber.</p> <p>Incorrect adjustment of rear axle shaft end play.</p> <p>Damaged or worn wheel bearing.</p> <p>Worn spline portion of rear axle shaft.</p> <p>Breakage of lead spring.</p> <p>Loosening of journal, connections or so no.</p> <p>Unbalance of the wheel and tire.</p> <p>Damage to the rubber parts such as suspension arm bush, shock absorber mounting bush.</p> <p>Deformed differential mounting member.</p> <p>Defective universal joints.</p> <p>Worn or damaged rear suspension member mounting insulator.</p> <p>Worn or seized sliding portion of drive shaft ball spline.</p> <p>Breakage of coil spring.</p>	<p>Tighten the wheel nuts.</p> <p>Tighten the bolts to the specified torque.</p> <p>Lubricate as required.</p> <p>Replace the shock absorber.</p> <p>Adjust the rear axle shaft end play</p> <p>Replace wheel bearing.</p> <p>Replace if necessary.</p> <p>Replace leaf spring.</p> <p>Tighten to the given torque.</p> <p>Balance wheel and tire.</p> <p>Replace the required parts.</p> <p>Replace.</p> <p>Adjust or replace.</p> <p>Replace the both side suspension member mounting insulator.</p> <p>Replace drive shaft assembly.</p> <p>Replace coil spring.</p>
Instability in driving	<p>Loosening of wheel nut.</p> <p>Damaged rear suspension arm rubber bush.</p> <p>Worn shock absorber.</p> <p>Defective wheel alignment</p> <p>1) coil spring wear.</p> <p>2) worn-out spline portion of drive shaft ball spline.</p>	<p>Tighten to the given torque.</p> <p>Replace the rubber bushes.</p> <p>Replace defective shock absorber.</p> <p>Replace coil spring.</p> <p>Replace drive shaft assembly.</p>

CHASSIS

Oil leakage	Damaged oil seal on rear axle shaft. Oil leakage from the differential carrier. Damaged dust cover of drive shaft. Damaged grease seal of rear axle shaft.	Replace the defective oil seal. Replace as required. Replace dust cover. Replace grease seal.
-------------	---	--

REAR AXLE-STATION WAGON

CONTENTS

DESCRIPTION	RA-12	INSPECTION	RA-14
REMOVAL	RA-12	ASSEMBLY	RA-14
DISASSEMBLY	RA-13		

DESCRIPTION

The rear axle for the station wagon, is of the semi-floating type. The axle is a pressed steel "Banjo" type housing. It is light in weight and is strong enough to withstand all torsional and bending loads.

The rear wheel bearings are of the presealed type, therefore no servicing is necessary. However, on the occasion the bearing is replaced the new bearing should be packed with an approved grease prior to installation.

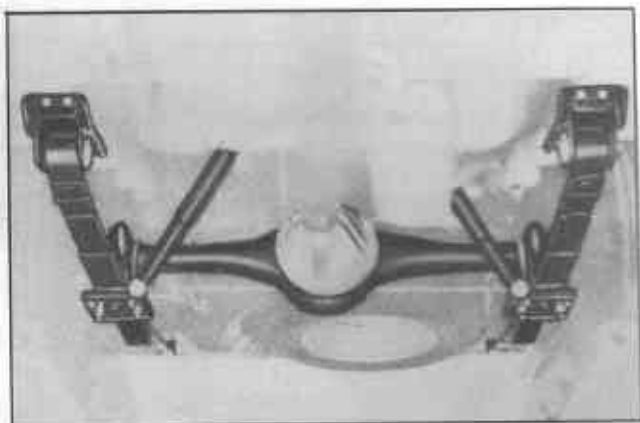

Fig. RA-24 Rear axle

REMOVAL

1. Remove the road wheel covers and loosen the four wheel nuts.

2. Jack up the rear of the vehicle and support it on stands.

3. Remove the wheel nuts and take off the two road wheels and brake drums.

Note: If the brake linings should hold the drum, slacken off the brake shoe adjuster a few notches.

4. Disconnect the brake hose from the brake tube.

5. Plug up the hose with a plastic cover or wooden peg to avoid the ingress of foreign matter.



Fig. RA-25 Three way connector

REAR AXLE & REAR SUSPENSION

6. Disconnect the hand brake rear cable from the balance lever assembly.

7. Remove the four bolts securing the propeller shaft flange yoke to the drive pinion companion flange (See Fig. RA-26).



Fig. RA-26 Removal of companion flange bolts

8. Release both lower shock absorber self locking nuts and slide the mounting eyes of the shock absorber off the pivot of the rear spring seat.

9. Support the rear axle with a hydraulic jack.

10. Loosen the 'U' bolt lock nuts. Remove the nuts from both rear spring shackles and take off the shackles from the rear spring eyes.

11. Remove the 'U' bolt lock nuts. Lower the jack and withdraw the rear axle assembly as shown in Figure RA-27.

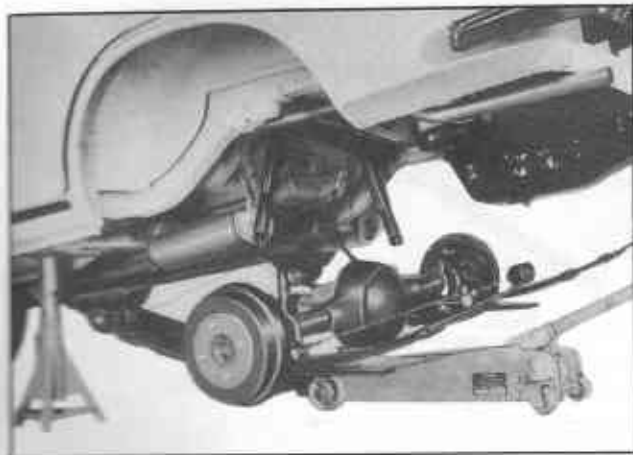

Fig. RA-27 Removal of rear axle

DISASSEMBLY

1. Disconnect the brake line ends from the wheel cylinders and remove the line complete with the three-way connector.

2. Remove the cross rod clamp and the balance lever arm from the rear axle case and both cross rod ends from the wheel cylinder lever assembly. Withdraw the hand brake linkage assembly.

3. Unscrew the oil drain plug and drain the oil from the axle case into a clean tray. It will be thus be possible to reuse the lubricant, provided it is in good condition.

4. Remove the four nuts securing the brake back plate to the axle case. Then draw out the axle shaft assembly together with the brake back plate and grease catcher, using sliding hammer (ST46780000) (See Fig. RA-29).



Fig. RA-28 Removing rear axle case end bolts

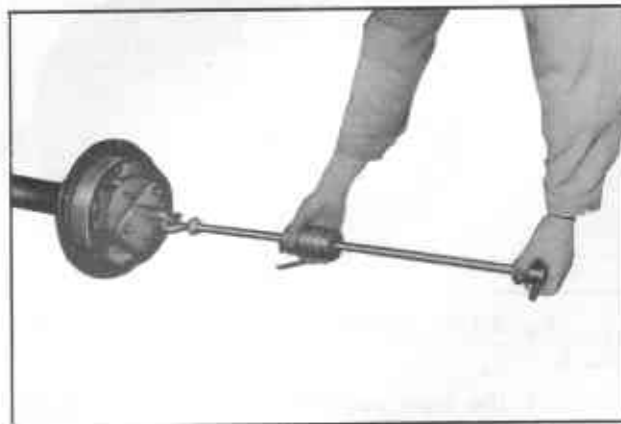

Fig. RA-29 Removing rear axle shaft assembly