

SECTION **CL**

GI

MA

EM

LC

EC

FE

CL

MT

AT

FA

RA

BR

ST

RS

BT

HA

EL

IDX

CONTENTS

PRECAUTIONS AND PREPARATION	2	HYDRAULIC CLUTCH CONTROL	7
Precautions	2	Clutch Master Cylinder	7
Special Service Tools.....	2	Operating Cylinder.....	8
Commercial Service Tools	2	CLUTCH RELEASE MECHANISM	9
NOISE, VIBRATION AND HARSHNESS (NVH)		CLUTCH DISC AND CLUTCH COVER	10
TROUBLESHOOTING	3	Clutch Disc.....	10
NVH Troubleshooting Chart.....	3	Clutch Cover and Flywheel.....	11
CLUTCH SYSTEM — Hydraulic Type	4	SERVICE DATA AND SPECIFICATIONS (SDS)	12
INSPECTION AND ADJUSTMENT	5	General Specifications	12
Adjusting Clutch Pedal.....	5	Inspection and Adjustment.....	12
Bleeding Procedure	6		

PRECAUTIONS AND PREPARATION

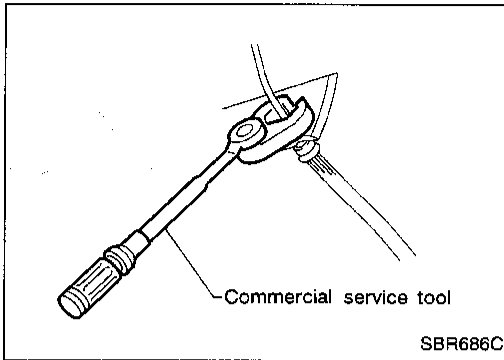

Precautions

- Recommended fluid is brake fluid DOT 3.
- Never reuse drained brake fluid.
- Be careful not to splash brake fluid on painted areas; it may cause paint damage. If brake fluid is splashed on painted areas, wash it away with water immediately.
- Use flare nut wrench when removing and installing clutch piping.
- Use new brake fluid to clean or wash all parts of master cylinder and operating cylinder.
- Never use mineral oils such as gasoline or kerosene. They will ruin the rubber parts of the hydraulic system.

WARNING:

After cleaning clutch disc, wipe it with a dust collector. Do not use compressed air.

Special Service Tools

The actual shapes of Kent-Moore tools may differ from those of special service tools illustrated here.

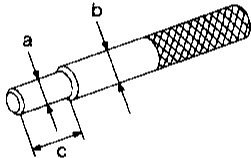
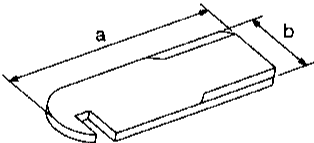
Tool number (Kent-Moore No.) Tool name	Description
ST20630000 (J26366) Clutch aligning bar	 <p>NT405</p> <p>Installing clutch cover and clutch disc</p> <p>a: 15.8 mm (0.622 in) dia. b: 22.9 mm (0.902 in) dia. c: 45.0 mm (1.772 in)</p>
ST20050240 (—) Diaphragm spring adjusting wrench	 <p>NT404</p> <p>Adjusting unevenness of diaphragm spring of clutch cover</p> <p>a: 150 mm (5.91 in) b: 25 mm (0.98 in)</p>

Commercial Service Tools

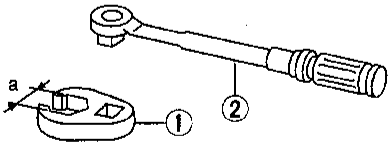
Tool name	Description
<ol style="list-style-type: none"> 1 Flare nut crowfoot 2 Torque wrench 	 <p>NT360</p> <p>Removing and installing clutch piping</p> <p>a: 10 mm (0.39 in)</p>

NOISE, VIBRATION AND HARSHNESS (NVH) TROUBLESHOOTING

NVH Troubleshooting Chart

Use the chart below to help you find the cause of the symptom. The numbers indicate the order of inspection. If necessary, repair or replace these parts.

Symptom		SUSPECTED PARTS (Possible Cause)											Reference page									
		CLUTCH PEDAL (Free play out of adjustment)	CLUTCH LINE (Air in line)	MASTER CYLINDER PISTON CUP (Damaged)	OPERATING CYLINDER PISTON CUP (Damaged)	ENGINE MOUNTING (Loose)	RELEASE BEARING (Worn, dirty or damaged)	CLUTCH DISC (Out of true)	CLUTCH DISC (Runout is excessive)	CLUTCH DISC (Lining broken)	CLUTCH DISC (Dirty or burned)	CLUTCH DISC (Oily)	CLUTCH DISC (Worn out)	CLUTCH DISC (Hardened)	CLUTCH DISC (Lack of spline grease)	DIAPHRAGM SPRING (Damaged)	DIAPHRAGM SPRING (Out of tip alignment)	CLUTCH COVER (Distortion)	FLYWHEEL (Discoloration)			
Symptom	Clutch grabs/chatters					1					2											
	Clutch pedal spongy		1	2	2																	
	Clutch noisy						1															
	Clutch slips	1									2	2				3		4	5			
	Clutch does not disengage	1	2	3	4				5	5	5	5			5	6	6	7				

GI

MA

EM

LG

EC

FE

CL

MT

AT

FA

RA

BR

ST

RS

BT

HA

EL

IDX

CLUTCH SYSTEM — Hydraulic Type

SEC. 300-305-306-321-465

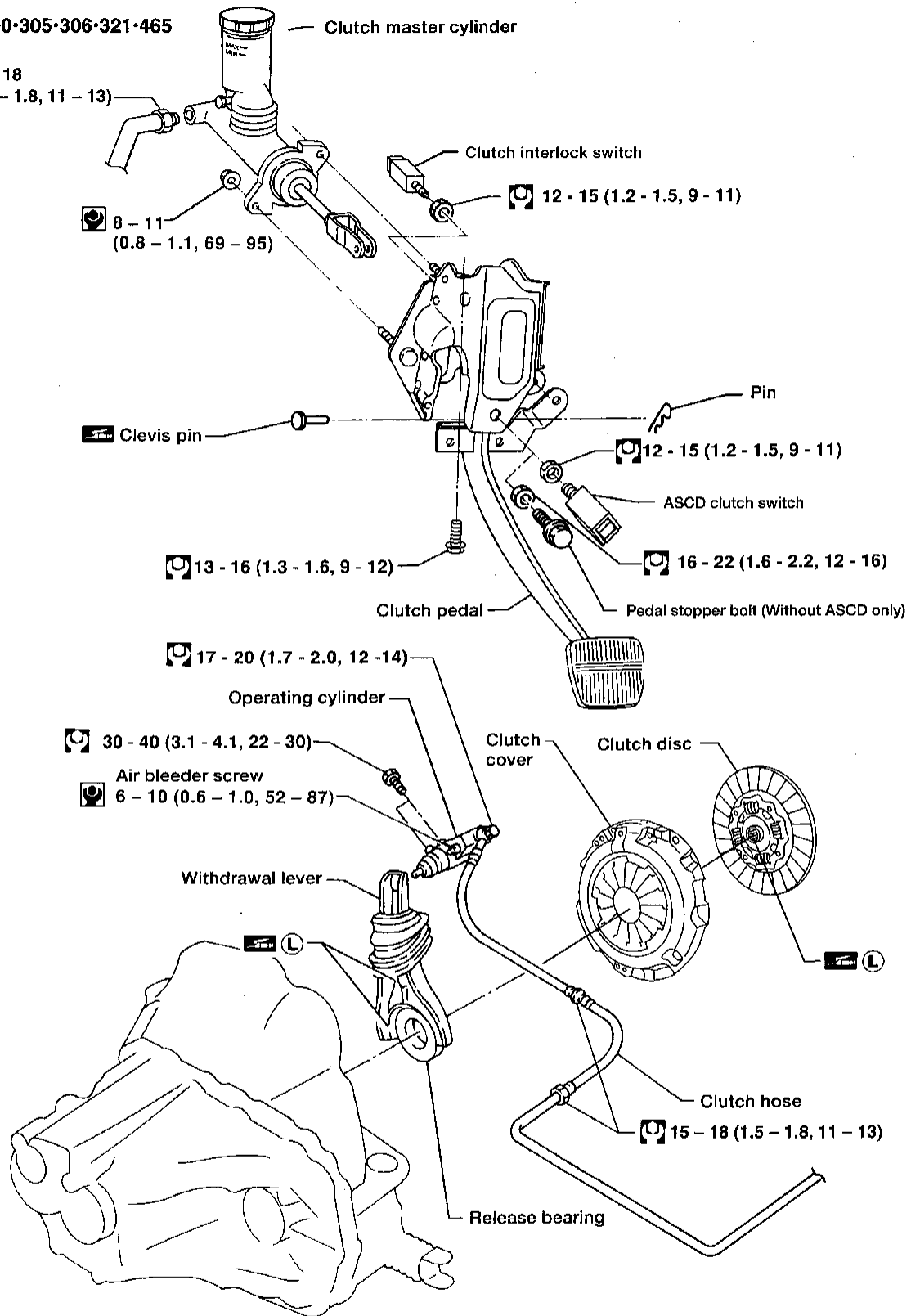

L : Apply lithium-based grease including molybdenum disulphide.

: N·m (kg-m, ft-lb)

: N·m (kg-m, in-lb)

ACL083

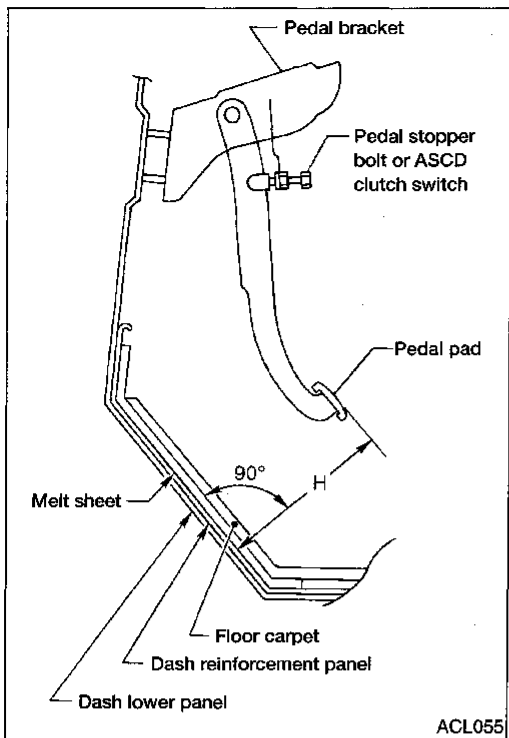

Adjusting Clutch Pedal

1. Adjust pedal height with pedal stopper bolt or ASCD clutch switch.

Pedal height "H":
168 - 178 mm (6.61 - 7.01 in)

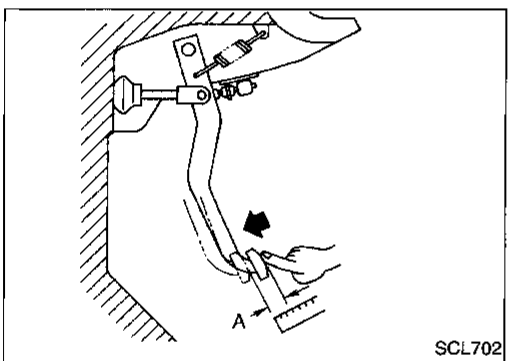

2. Adjust pedal free play with master cylinder push rod. Then tighten lock nut.

Pedal free play "A":
9 - 16 mm (0.35 - 0.63 in)

- Push or step on the clutch pedal until resistance is felt, and check the distance the pedal moves.

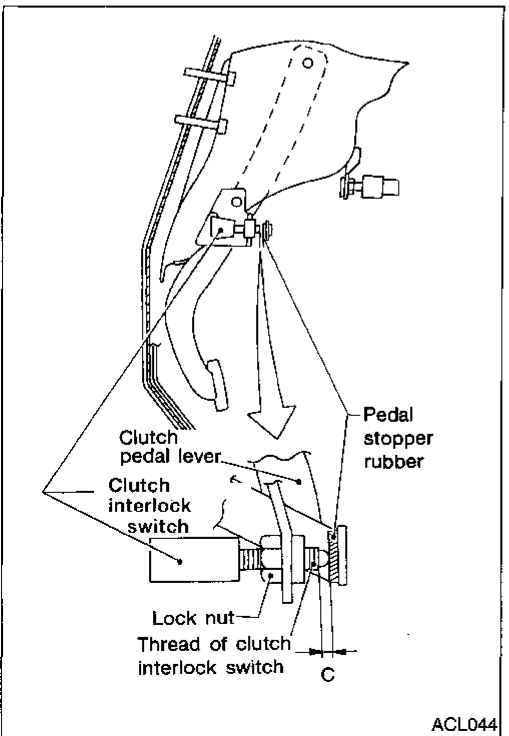

3. Adjust clearance "C" shown in the figure while fully depressing clutch pedal fully.

Clearance "C":
0.1 - 1.0 mm (0.004 - 0.039 in)

GI

MA

EM

LC

EC

FE

CL

MT

AT

FA

RA

BR

ST

RS

BT

HA

EL

IDX

INSPECTION AND ADJUSTMENT

Adjusting Clutch Pedal (Cont'd)

Bleeding Procedure

Bleed air from master cylinder and then operating cylinder.

1. Fill master cylinder reservoir tank with new brake fluid.
2. Connect a transparent vinyl hose to air bleeder.
3. Slowly depress clutch pedal to its full stroke length and release it completely. Repeat this operation several times at two to three second intervals.
4. Open air bleeder with clutch pedal fully depressed.
5. Close air bleeder.
6. Release clutch pedal and wait at least five seconds.
7. Repeat steps 3 through 6 above until air bubbles no longer appear in brake fluid.

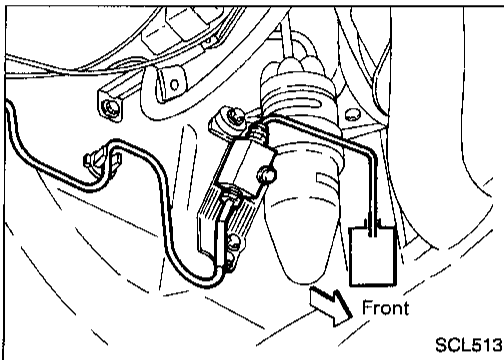
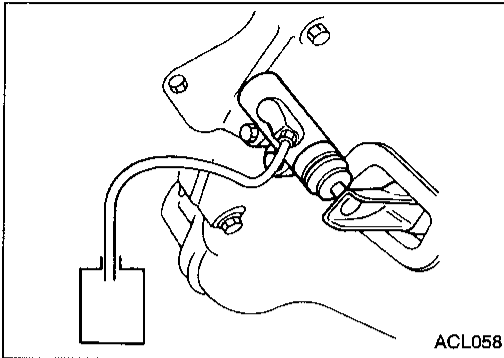

Clutch Master Cylinder

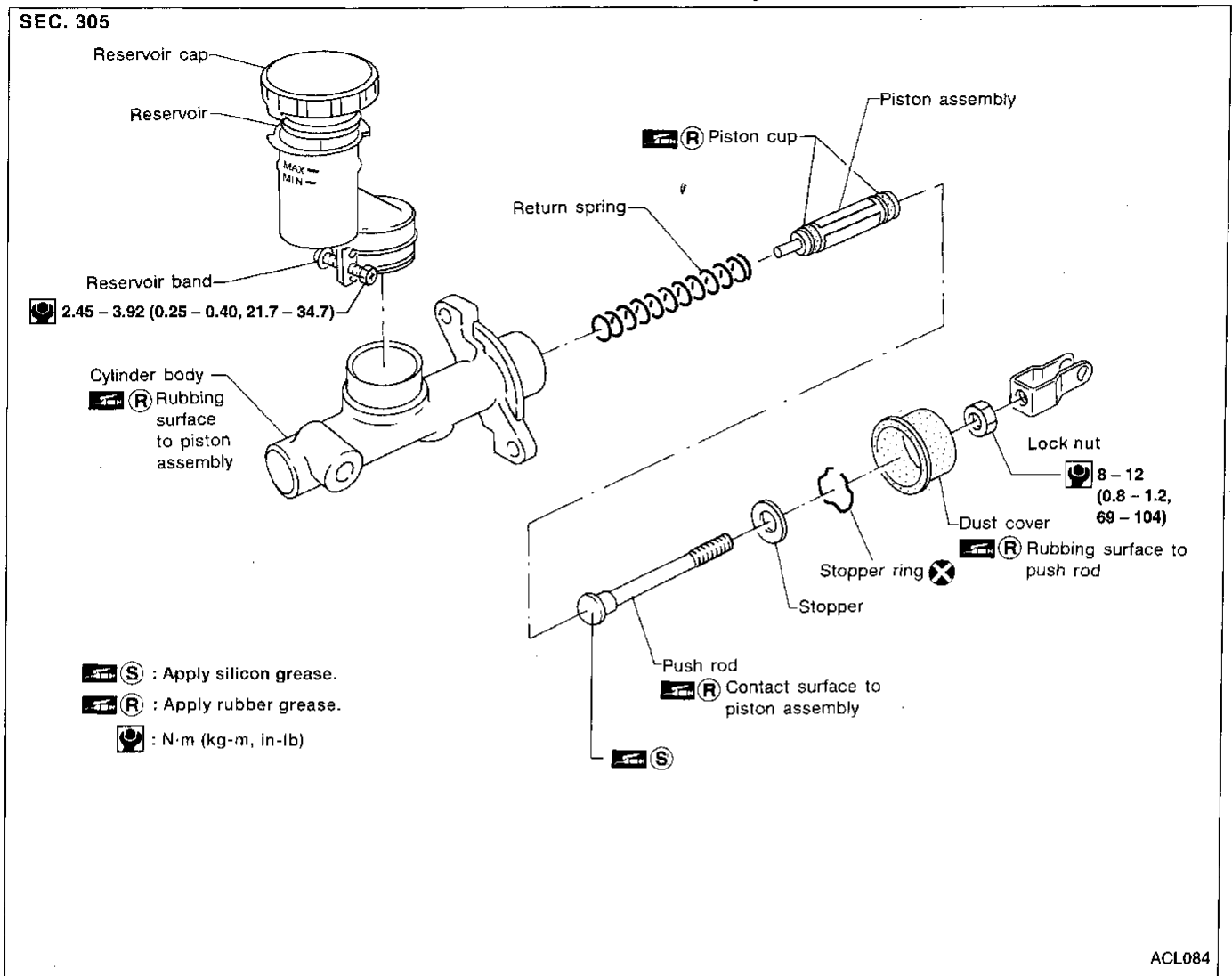

GI

MA

EM

LC

EC

FE

CL

MT

AT

FA

RA

BR

DISASSEMBLY AND ASSEMBLY

- Use a screwdriver to remove stopper ring while pushing push rod into cylinder.
- When installing stopper ring, tap in lightly while pushing push rod into cylinder.

ST

RS

BT

INSPECTION

Check the following items, and replace if necessary:

- Rubbing surface of cylinder and piston, for uneven wear, rust or damage
- Piston with piston cup, for wear or damage
- Return spring, for wear or damage
- Dust cover, for cracks, deformation or damage
- Reservoir, for deformation or damage

HA

EL

IDX

Operating Cylinder

SEC. 306

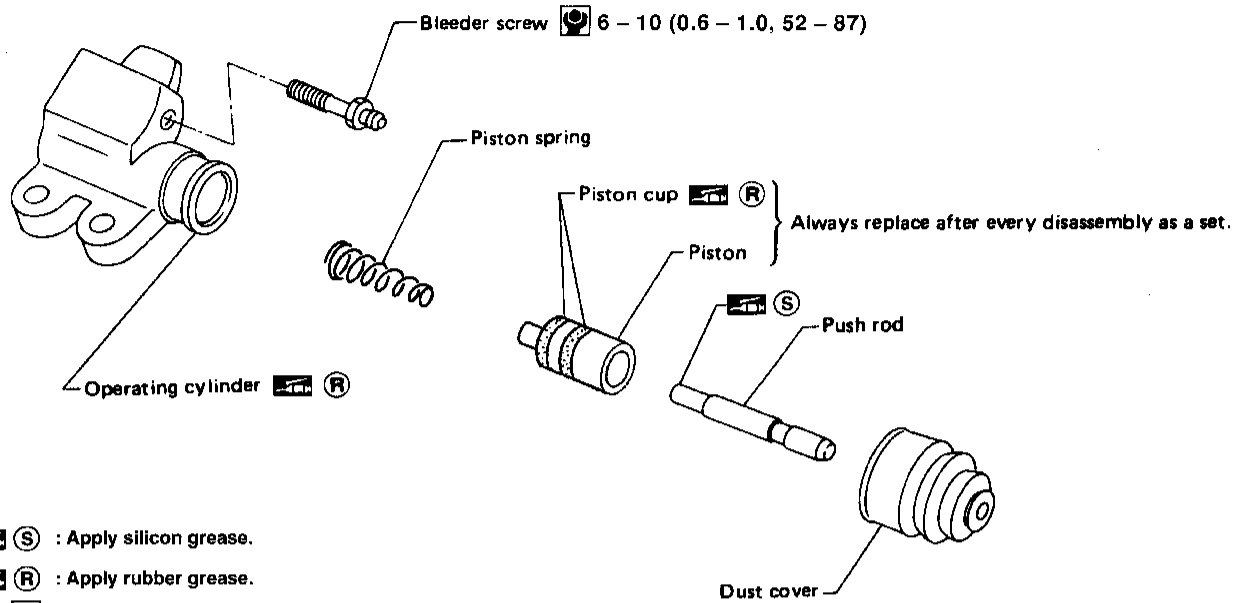

ACL059

INSPECTION

Check the following items, and replace if necessary:

- Rubbing surface of cylinder and piston, for uneven wear, rust or damage
- Piston with piston cup, for wear or damage
- Piston spring, for wear or damage
- Dust cover, for cracks, deformation or damage

CLUTCH RELEASE MECHANISM

SEC. 321

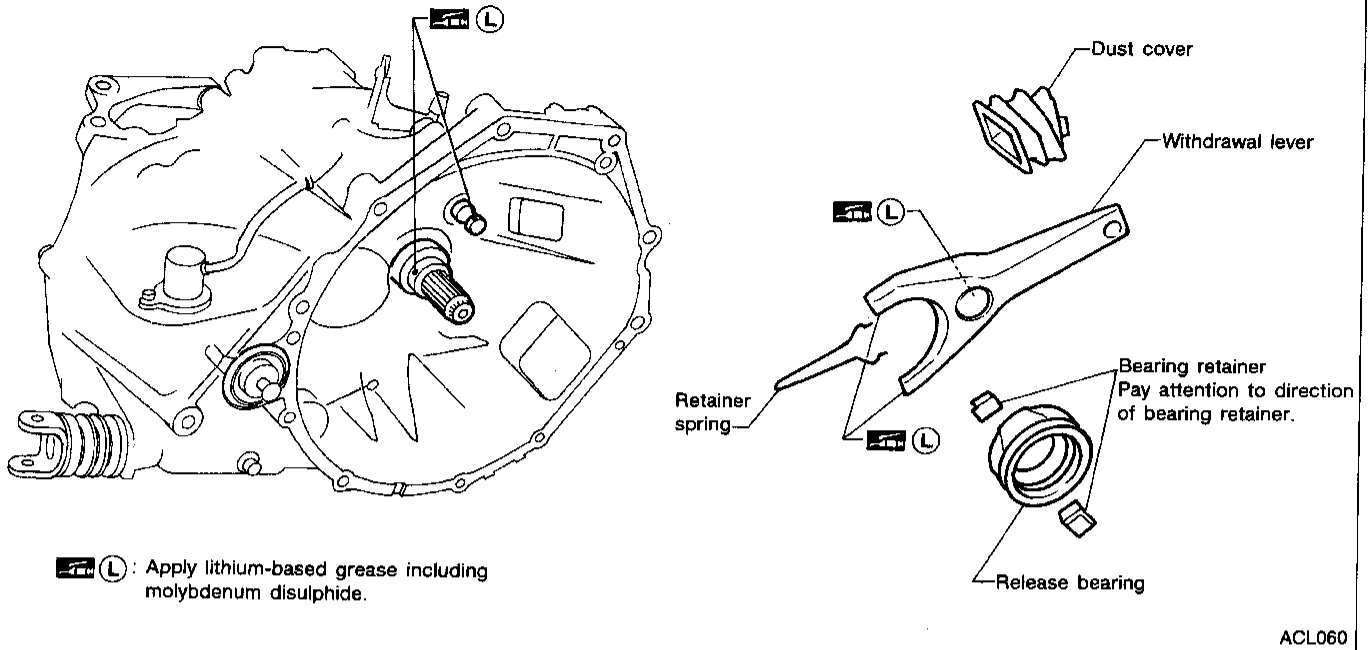

GI

MA

EM

LC

EC

FE

CL

ACL060

INSPECTION

Check the following items, and replace if necessary:

- Release bearing, to see that it rolls freely and is free from noise, cracks, pitting or wear
- Release sleeve and withdrawal lever rubbing surface, for wear, rust or damage

MT

AT

FA

RA

BR

ST

RS

BT

HA

EL

IDX

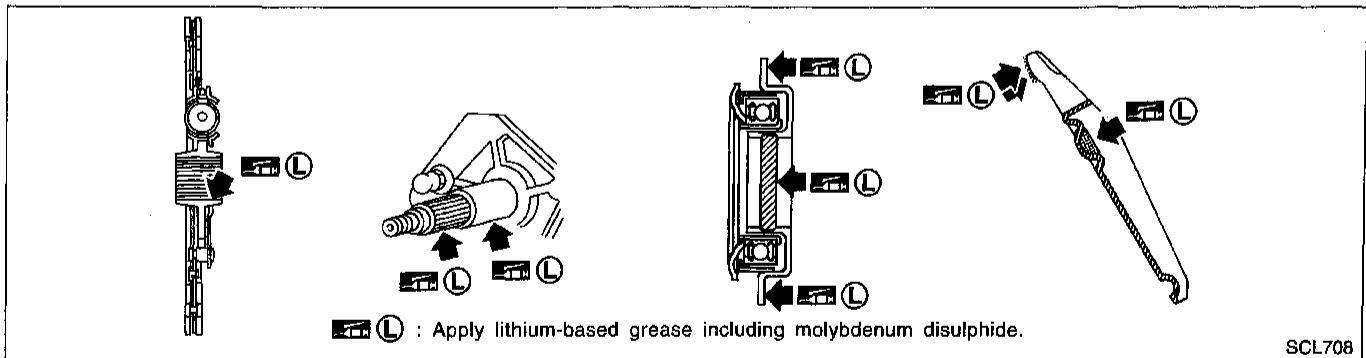

LUBRICATION

- Apply recommended grease to contact surface and rubbing surface.
- **Too much lubricant might damage clutch disc facing.**

CLUTCH DISC AND CLUTCH COVER

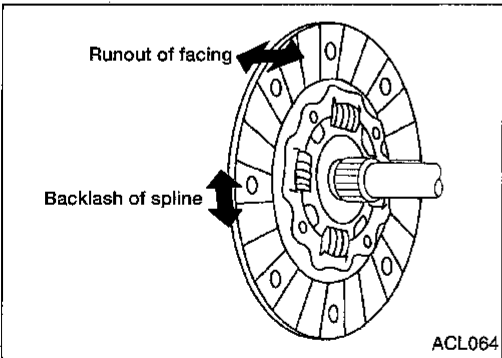
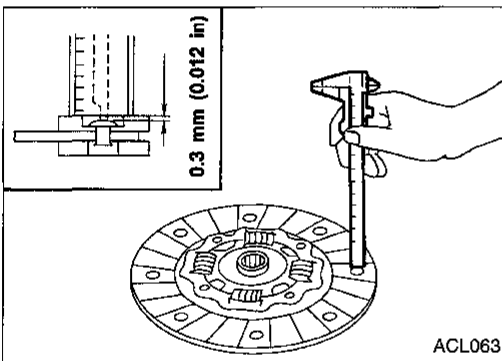
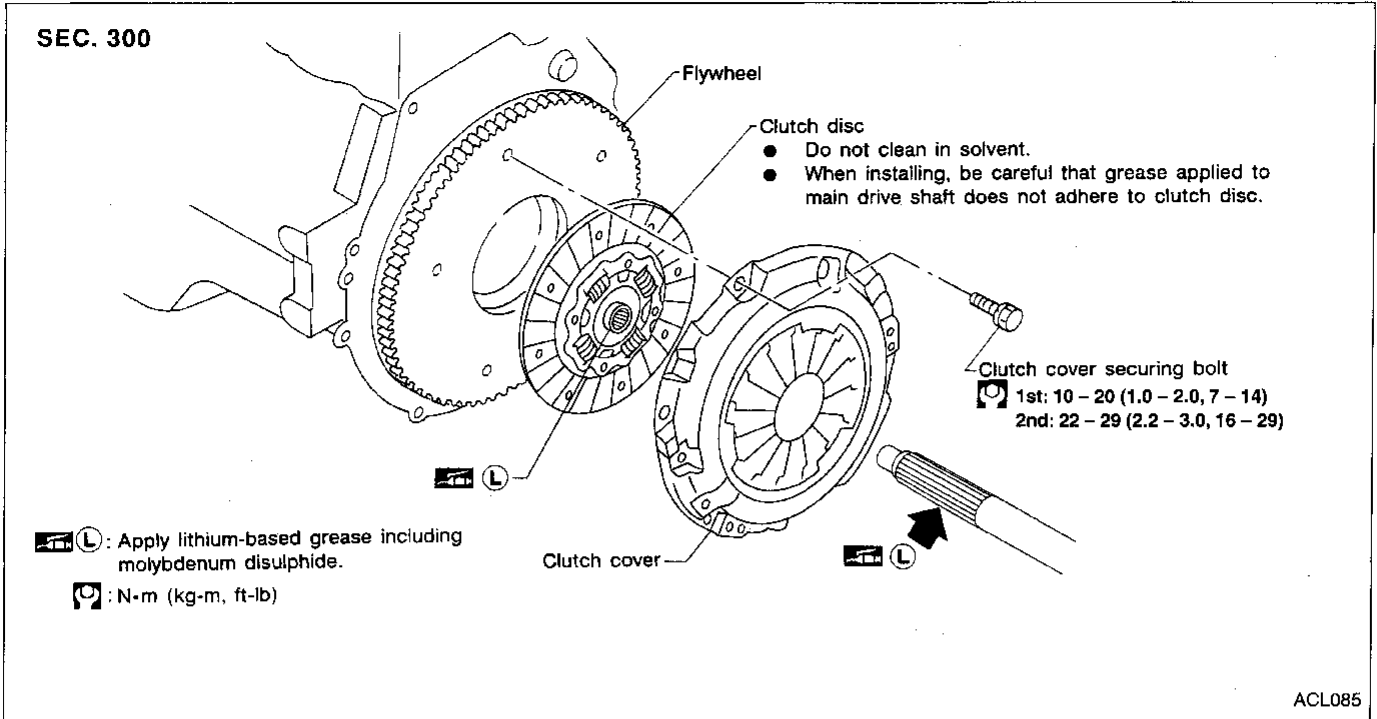

Clutch Disc

INSPECTION

Check the following items, and replace if necessary:

- Clutch disc, for burns, discoloration, oil or grease leakage
- Clutch disc, for wear of facing

Wear limit of facing surface to rivet head:

0.3 mm (0.012 in)

- Clutch disc, for backlash of spline and runout of facing.

Maximum backlash of spline (at outer edge of disc):

0.9 mm (0.035 in)

Runout limit:

1.0 mm (0.039 in)

Distance of runout check point (from hub center)

107.5 mm (4.23 in)

INSTALLATION

- Apply recommended grease to contact surface of splines.
- Too much lubricant might damage clutch facing.

CLUTCH DISC AND CLUTCH COVER

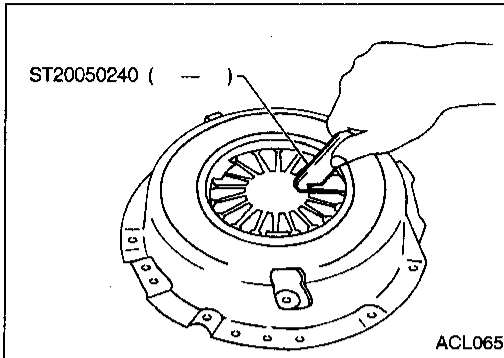

Clutch Cover and Flywheel

INSPECTION AND ADJUSTMENT

- Check clutch cover while installed on vehicle, for uneven diaphragm spring toe height.
Uneven limit:
0.7 mm (0.028 in)
- If out of limit, adjust the height with Tool.

GI

MA

EM

LC

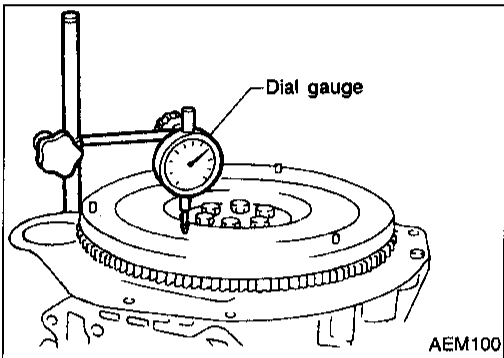

FLYWHEEL INSPECTION

CAUTION:

Do not allow any magnetic materials to contact the ring gear teeth.

- Inspect contact surface of flywheel for slight burns or discoloration. Clean flywheel with emery paper.
- Check flywheel runout.

Maximum allowable runout:

Refer to EM section ("Inspection", "CYLINDER BLOCK").

EC

FE

CL

MT

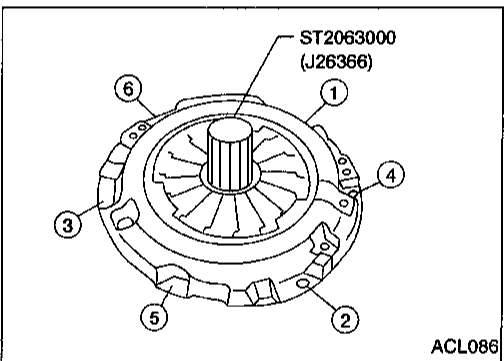

INSTALLATION

- Insert Tool into clutch disc hub when installing clutch cover and disc.
- Be careful not to allow grease to contaminate clutch facing.
- Tighten bolts in numerical order, in two steps.

First step:

⊗: 10 - 20 N·m (1.0 - 2.0 kg·m, 7 - 14 ft·lb)

Final step:

⊗: 22 - 29 N·m (2.2 - 3.0 kg·m, 16 - 22 ft·lb)

AT

FA

RA

BR

ST

RS

BT

HA

EL

IDX

SERVICE DATA AND SPECIFICATIONS (SDS)

General Specifications

CLUTCH CONTROL SYSTEM

Type of clutch control	Hydraulic
------------------------	-----------

CLUTCH MASTER CYLINDER

Inner diameter	mm (in)	15.87 (5/8)
----------------	---------	-------------

CLUTCH OPERATING CYLINDER

Inner diameter	mm (in)	19.05 (3/4)
----------------	---------	-------------

CLUTCH DISC

Unit: mm (in)

Model	225
Facing size (Outer dia. x inner dia. x thickness)	225 x 150 x 3.5 (8.86 x 5.91 x 0.138)
Thickness of disc assembly With load	7.9 - 8.3 (0.311 - 0.327) with 4,904 N (500 kg, 1,103 lb)

CLUTCH COVER

Model	225
Full-load	N (kg, lb) 4,904 (500, 1,103)

Inspection and Adjustment

CLUTCH PEDAL

Unit: mm (in)

Pedal height "H"*1	168 - 178 (6.61 - 7.01)
Pedal free play "A" (at pedal pad)	9 - 16 (0.35 - 0.63)
Clearance "C" (between pedal stopper rubber and clutch interlock switch)*2	0.1 - 1.0 (0.004 - 0.039)

*1: Measured from surface of dash reinforcement panel

*2: Clutch pedal fully depressed

CLUTCH DISC

Unit: mm (in)

Model	225
Wear limit of facing surface to rivet head	0.3 (0.012)
Runout limit of facing	1.0 (0.039)
Distance of runout check point (from hub center)	107.5 (4.23)
Maximum backlash of spline (at outer edge disc)	0.9 (0.035)

CLUTCH COVER

Unit: mm (in)

Model	225
Uneven limit of diaphragm spring toe height	0.7 (0.028)