

SECTION IP
INSTRUMENT PANEL

A
 B
 C
 D
 E
 F
 G
 H
 I
IP
 K
 L
 M
 N
 O
 P

CONTENTS

<p>PRECAUTION 2</p> <p>PRECAUTIONS 2</p> <p style="padding-left: 20px;">Precaution for Supplemental Restraint System (SRS) "AIR BAG" and "SEAT BELT PRE-TENSIONER"2</p> <p style="padding-left: 20px;">Precautions Necessary for Steering Wheel Rotation after Battery Disconnect2</p> <p style="padding-left: 20px;">Precaution for Work3</p> <p>PREPARATION 4</p> <p>PREPARATION 4</p> <p style="padding-left: 20px;">Special Service Tools4</p> <p style="padding-left: 20px;">Commercial Service Tools4</p> <p>SYMPTOM DIAGNOSIS 5</p> <p>SQUEAK AND RATTLE TROUBLE DIAGNOSES 5</p> <p style="padding-left: 20px;">Work Flow5</p> <p style="padding-left: 20px;">Generic Squeak and Rattle Troubleshooting7</p> <p style="padding-left: 20px;">Diagnostic Worksheet9</p> <p>REMOVAL AND INSTALLATION11</p> <p>INSTRUMENT PANEL ASSEMBLY11</p> <p style="padding-left: 20px;">Exploded View 11</p>	<p style="padding-left: 20px;">Removal and Installation - Instrument Panel12</p> <p style="padding-left: 20px;">Removal and Installation - Steering Column Covers13</p> <p>CENTER CONSOLE ASSEMBLY 14</p> <p style="padding-left: 20px;">Removal and Installation 14</p> <p>CLUSTER LID A 16</p> <p style="padding-left: 20px;">Removal and Installation16</p> <p>CLUSTER LID C 17</p> <p style="padding-left: 20px;">Removal and Installation 17</p> <p>INSTRUMENT LOWER PANEL LH 19</p> <p style="padding-left: 20px;">Removal and Installation19</p> <p>GLOVE BOX ASSEMBLY 20</p> <p style="padding-left: 20px;">Removal and Installation20</p> <p>CVT FINISHER 21</p> <p style="padding-left: 20px;">Removal and Installation21</p> <p>UNIT DISASSEMBLY AND ASSEMBLY ...22</p> <p>CENTER CONSOLE ASSEMBLY 22</p> <p style="padding-left: 20px;">Exploded View22</p> <p style="padding-left: 20px;">Disassembly and Assembly22</p>
---	---

PRECAUTIONS

< PRECAUTION >

PRECAUTION

PRECAUTIONS

Precaution for Supplemental Restraint System (SRS) "AIR BAG" and "SEAT BELT PRE-TENSIONER"

INFOID:000000006391390

The Supplemental Restraint System such as "AIR BAG" and "SEAT BELT PRE-TENSIONER", used along with a front seat belt, helps to reduce the risk or severity of injury to the driver and front passenger for certain types of collision. This system includes seat belt switch inputs and dual stage front air bag modules. The SRS system uses the seat belt switches to determine the front air bag deployment, and may only deploy one front air bag, depending on the severity of a collision and whether the front occupants are belted or unbelted. Information necessary to service the system safely is included in the SR and SB section of this Service Manual.

WARNING:

- To avoid rendering the SRS inoperative, which could increase the risk of personal injury or death in the event of a collision which would result in air bag inflation, all maintenance must be performed by an authorized NISSAN/INFINITI dealer.
- Improper maintenance, including incorrect removal and installation of the SRS, can lead to personal injury caused by unintentional activation of the system. For removal of Spiral Cable and Air Bag Module, see the SR section.
- Do not use electrical test equipment on any circuit related to the SRS unless instructed to in this Service Manual. SRS wiring harnesses can be identified by yellow and/or orange harnesses or harness connectors.

PRECAUTIONS WHEN USING POWER TOOLS (AIR OR ELECTRIC) AND HAMMERS

WARNING:

- When working near the Airbag Diagnosis Sensor Unit or other Airbag System sensors with the Ignition ON or engine running, DO NOT use air or electric power tools or strike near the sensor(s) with a hammer. Heavy vibration could activate the sensor(s) and deploy the air bag(s), possibly causing serious injury.
- When using air or electric power tools or hammers, always switch the Ignition OFF, disconnect the battery, and wait at least 3 minutes before performing any service.

Precautions Necessary for Steering Wheel Rotation after Battery Disconnect

INFOID:000000006921813

NOTE:

- Before removing and installing any control units, first turn the push-button ignition switch to the LOCK position, then disconnect both battery cables.
- After finishing work, confirm that all control unit connectors are connected properly, then re-connect both battery cables.
- Always use CONSULT to perform self-diagnosis as a part of each function inspection after finishing work. If a DTC is detected, perform trouble diagnosis according to self-diagnosis results.

This vehicle is equipped with a push-button ignition switch and a steering lock unit.

If the battery is disconnected or discharged, the steering wheel will lock and cannot be turned.

If turning the steering wheel is required with the battery disconnected or discharged, follow the procedure below before starting the repair operation.

OPERATION PROCEDURE

1. Connect both battery cables.

NOTE:

Supply power using jumper cables if battery is discharged.

2. Carry the Intelligent Key or insert it to the key slot and turn the push-button ignition switch to ACC position. (At this time, the steering lock will be released.)
3. Disconnect both battery cables. The steering lock will remain released with both battery cables disconnected and the steering wheel can be turned.
4. Perform the necessary repair operation.

PRECAUTIONS

< PRECAUTION >

5. When the repair work is completed, re-connect both battery cables. With the brake pedal released, turn the push-button ignition switch from ACC position to ON position, then to LOCK position. (The steering wheel will lock when the push-button ignition switch is turned to LOCK position.)
6. Perform self-diagnosis check of all control units using CONSULT.

Precaution for Work

INFOID:000000006921814

- When removing or disassembling each component, be careful not to damage or deform it. If a component may be subject to interference, be sure to protect it with a shop cloth.
- When removing (disengaging) components with a screwdriver or similar tool, be sure to wrap the component with a shop cloth or vinyl tape to protect it.
- Protect the removed parts with a shop cloth and prevent them from being dropped.
- Replace a deformed or damaged clip.
- If a part is specified as a non-reusable part, always replace it with new one.
- Be sure to tighten bolts and nuts securely to the specified torque.
- After installation is complete, be sure to check that each part works properly.
- Follow the steps below to clean components.
 - Water soluble dirt: Dip a soft cloth into lukewarm water, and wring the water out of the cloth to wipe the dirty area.
Then rub with a soft and dry cloth.
 - Oily dirt: Dip a soft cloth into lukewarm water with mild detergent (concentration: within 2 to 3%), and wipe the dirty area.
Then dip a cloth into fresh water, and wring the water out of the cloth to wipe the detergent off. Then rub with a soft and dry cloth.
- Do not use organic solvent such as thinner, benzene, alcohol, or gasoline.
- For genuine leather seats, use a genuine leather seat cleaner.

A
B
C
D
E
F
G
H
I
K
L
M
N
O
P

IP

PREPARATION

< PREPARATION >

PREPARATION

PREPARATION

Special Service Tools

INFOID:000000006391393

The actual shapes of Kent-Moore tools may differ from those of special service tools illustrated here.

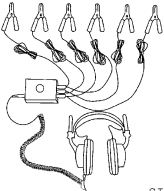
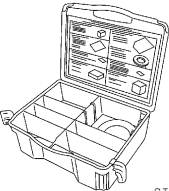
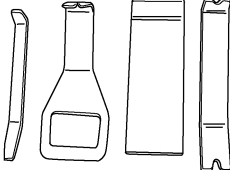
Tool number (Kent-Moore No.) Tool name	Description
(J-39570) Chassis ear  SIIA0993E	Locating the noise
(J-43980) NISSAN Squeak and Rattle Kit  SIIA0994E	Repairing the cause of noise
(J-46534) Trim Tool Set  AWJIA04832Z	Removing trim components

Commercial Service Tools

INFOID:000000006391394

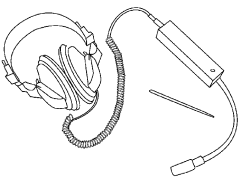
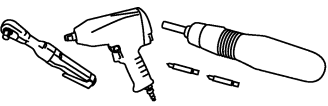
Tool name	Description
Engine ear  SIIA0995E	Locating the noise
Power tool  PIIB1407E	Loosening bolts, nuts and screws

SQUEAK AND RATTLE TROUBLE DIAGNOSES

< SYMPTOM DIAGNOSIS >

SYMPTOM DIAGNOSIS

SQUEAK AND RATTLE TROUBLE DIAGNOSES

Work Flow

INFOID:000000006921815

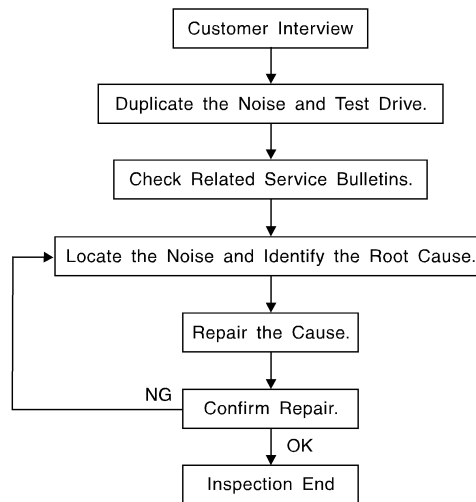

SBT842

CUSTOMER INTERVIEW

Interview the customer if possible, to determine the conditions that exist when the noise occurs. Use the Diagnostic Worksheet during the interview to document the facts and conditions when the noise occurs and any customer's comments; refer to [IP-9, "Diagnostic Worksheet"](#). This information is necessary to duplicate the conditions that exist when the noise occurs.

- The customer may not be able to provide a detailed description or the location of the noise. Attempt to obtain all the facts and conditions that exist when the noise occurs (or does not occur).
- If there is more than one noise in the vehicle, be sure to diagnose and repair the noise that the customer is concerned about. This can be accomplished by test driving the vehicle with the customer.
- After identifying the type of noise, isolate the noise in terms of its characteristics. The noise characteristics are provided so the customer, service adviser and technician are all speaking the same language when defining the noise.
- Squeak —(Like tennis shoes on a clean floor)
Squeak characteristics include the light contact/fast movement/brought on by road conditions/hard surfaces = higher pitch noise/softer surfaces = lower pitch noises/edge to surface = chirping.
- Creak—(Like walking on an old wooden floor)
Creak characteristics include firm contact/slow movement/twisting with a rotational movement/pitch dependent on materials/often brought on by activity.
- Rattle—(Like shaking a baby rattle)
Rattle characteristics include the fast repeated contact/vibration or similar movement/loose parts/missing clip or fastener/incorrect clearance.
- Knock —(Like a knock on a door)
Knock characteristics include hollow sounding/sometimes repeating/often brought on by driver action.
- Tick—(Like a clock second hand)
Tick characteristics include gentle contacting of light materials/loose components/can be caused by driver action or road conditions.
- Thump—(Heavy, muffled knock noise)
Thump characteristics include softer knock/dead sound often brought on by activity.
- Buzz—(Like a bumble bee)
Buzz characteristics include high frequency rattle/firm contact.
- Often the degree of acceptable noise level will vary depending upon the person. A noise that you may judge as acceptable may be very irritating to the customer.
- Weather conditions, especially humidity and temperature, may have a great effect on noise level.

DUPLICATE THE NOISE AND TEST DRIVE

SQUEAK AND RATTLE TROUBLE DIAGNOSES

< SYMPTOM DIAGNOSIS >

If possible, drive the vehicle with the customer until the noise is duplicated. Note any additional information on the Diagnostic Worksheet regarding the conditions or location of the noise. This information can be used to duplicate the same conditions when you confirm the repair.

If the noise can be duplicated easily during the test drive, to help identify the source of the noise, try to duplicate the noise with the vehicle stopped by doing one or all of the following:

- 1) Close a door.
 - 2) Tap or push/pull around the area where the noise appears to be coming from.
 - 3) Rev the engine.
 - 4) Use a floor jack to recreate vehicle "twist".
 - 5) At idle, apply engine load (electrical load, half-clutch on M/T model, drive position on CVT and A/T models).
 - 6) Raise the vehicle on a hoist and hit a tire with a rubber hammer.
- Drive the vehicle and attempt to duplicate the conditions the customer states exist when the noise occurs.
 - If it is difficult to duplicate the noise, drive the vehicle slowly on an undulating or rough road to stress the vehicle body.

CHECK RELATED SERVICE BULLETINS

After verifying the customer concern or symptom, check ASIST for Technical Service Bulletins (TSBs) related to that concern or symptom.

If a TSB relates to the symptom, follow the procedure to repair the noise.

LOCATE THE NOISE AND IDENTIFY THE ROOT CAUSE

1. Narrow down the noise to a general area. To help pinpoint the source of the noise, use a listening tool (Chassis Ear: J-39570, Engine Ear: J-39565 and mechanic's stethoscope).
2. Narrow down the noise to a more specific area and identify the cause of the noise by:
 - removing the components in the area that you suspect the noise is coming from.
Do not use too much force when removing clips and fasteners, otherwise clips and fasteners can be broken or lost during the repair, resulting in the creation of new noise.
 - tapping or pushing/pulling the component that you suspect is causing the noise.
Do not tap or push/pull the component with excessive force, otherwise the noise will be eliminated only temporarily.
 - feeling for a vibration with your hand by touching the component(s) that you suspect is (are) causing the noise.
 - placing a piece of paper between components that you suspect are causing the noise.
 - looking for loose components and contact marks.
Refer to [IP-7. "Generic Squeak and Rattle Troubleshooting"](#).

REPAIR THE CAUSE

- If the cause is a loose component, tighten the component securely.
- If the cause is insufficient clearance between components:
 - separate components by repositioning or loosening and retightening the component, if possible.
 - insulate components with a suitable insulator such as urethane pads, foam blocks, felt cloth tape or urethane tape. A NISSAN Squeak and Rattle Kit (J-43980) is available through your authorized NISSAN Parts Department.

CAUTION:

Do not use excessive force as many components are constructed of plastic and may be damaged.

Always check with the Parts Department for the latest parts information.

The following materials are contained in the NISSAN Squeak and Rattle Kit (J-43980). Each item can be ordered separately as needed.

URETHANE PADS [1.5 mm (0.059 in) thick]

Insulates connectors, harness, etc.

76268-9E005: 100×135 mm (3.94×5.31 in)/76884-71L01: 60×85 mm (2.36×3.35 in)/76884-71L02: 15×25 mm (0.59×0.98 in)

INSULATOR (Foam blocks)

Insulates components from contact. Can be used to fill space behind a panel.

73982-9E000: 45 mm (1.77 in) thick, 50×50 mm (1.97×1.97 in)/73982-50Y00: 10 mm (0.39 in) thick, 50×50 mm (1.97×1.97 in)

INSULATOR (Light foam block)

80845-71L00: 30 mm (1.18 in) thick, 30×50 mm (1.18×1.97 in)

FELT CLOTH TAPE

Used to insulate where movement does not occur. Ideal for instrument panel applications.

68370-4B000: 15×25 mm (0.59×0.98 in) pad/68239-13E00: 5 mm (0.20 in) wide tape roll. The following materials not found in the kit can also be used to repair squeaks and rattles.

SQUEAK AND RATTLE TROUBLE DIAGNOSES

< SYMPTOM DIAGNOSIS >

UHMW (TEFLON) TAPE

Insulates where slight movement is present. Ideal for instrument panel applications.

SILICONE GREASE

Used instead of UHMW tape that will be visible or not fit.

Note: Will only last a few months.

SILICONE SPRAY

Use when grease cannot be applied.

DUCT TAPE

Use to eliminate movement.

CONFIRM THE REPAIR

Confirm that the cause of a noise is repaired by test driving the vehicle. Operate the vehicle under the same conditions as when the noise originally occurred. Refer to the notes on the Diagnostic Worksheet.

Generic Squeak and Rattle Troubleshooting

INFOID:000000006921816

Refer to Table of Contents for specific component removal and installation information.

INSTRUMENT PANEL

Most incidents are caused by contact and movement between:

1. The cluster lid A and instrument panel
2. Acrylic lens and combination meter housing
3. Instrument panel to front pillar garnish
4. Instrument panel to windshield
5. Instrument panel pins
6. Wiring harnesses behind the combination meter
7. A/C defroster duct and duct joint

These incidents can usually be located by tapping or moving the components to duplicate the noise or by pressing on the components while driving to stop the noise. Most of these incidents can be repaired by applying felt cloth tape or silicone spray (in hard to reach areas). Urethane pads can be used to insulate wiring harness.

CAUTION:

Do not use silicone spray to isolate a squeak or rattle. If you saturate the area with silicone, you will not be able to recheck the repair.

CENTER CONSOLE

Components to pay attention to include:

1. Shift selector assembly cover to finisher
2. A/C control unit and cluster lid C
3. Wiring harnesses behind audio and A/C control unit

The instrument panel repair and isolation procedures also apply to the center console.

DOORS

Pay attention to the:

1. Finisher and inner panel making a slapping noise
2. Inside handle escutcheon to door finisher
3. Wiring harnesses tapping
4. Door striker out of alignment causing a popping noise on starts and stops

Tapping or moving the components or pressing on them while driving to duplicate the conditions can isolate many of these incidents. You can usually insulate the areas with felt cloth tape or insulator foam blocks from the NISSAN Squeak and Rattle Kit (J-43980) to repair the noise.

TRUNK

Trunk noises are often caused by a loose jack or loose items put into the trunk by the owner.

In addition look for:

1. Trunk lid bumpers out of adjustment
2. Trunk lid striker out of adjustment
3. The trunk lid torsion bars knocking together

A
B
C
D
E
F
G
H
I
IP
K
L
M
N
O
P

SQUEAK AND RATTLE TROUBLE DIAGNOSES

< SYMPTOM DIAGNOSIS >

4. A loose license plate or bracket

Most of these incidents can be repaired by adjusting, securing or insulating the item(s) or component(s) causing the noise.

SUNROOF/HEADLINING

Noises in the sunroof/headlining area can often be traced to one of the following:

1. Sunroof lid, rail, linkage or seals making a rattle or light knocking noise
2. Sun visor shaft shaking in the holder
3. Front or rear windshield touching headliner and squeaking

Again, pressing on the components to stop the noise while duplicating the conditions can isolate most of these incidents. Repairs usually consist of insulating with felt cloth tape.

OVERHEAD CONSOLE (FRONT AND REAR)

Overhead console noises are often caused by the console panel clips not being engaged correctly. Most of these incidents are repaired by pushing up on the console at the clip locations until the clips engage.

In addition look for:

1. Loose harness or harness connectors.
2. Front console map/reading lamp lens loose.
3. Loose screws at console attachment points.

SEATS

When isolating seat noise it's important to note the position the seat is in and the load placed on the seat when the noise is present. These conditions should be duplicated when verifying and isolating the cause of the noise.

Cause of seat noise include:

1. Headrest rods and holder
2. A squeak between the seat pad cushion and frame
3. The rear seatback lock and bracket

These noises can be isolated by moving or pressing on the suspected components while duplicating the conditions under which the noise occurs. Most of these incidents can be repaired by repositioning the component or applying urethane tape to the contact area.

UNDERHOOD

Some interior noise may be caused by components under the hood or on the engine wall. The noise is then transmitted into the passenger compartment.

Causes of transmitted underhood noise include:

1. Any component installed to the engine wall
2. Components that pass through the engine wall
3. Engine wall mounts and connectors
4. Loose radiator installation pins
5. Hood bumpers out of adjustment
6. Hood striker out of adjustment

These noises can be difficult to isolate since they cannot be reached from the interior of the vehicle. The best method is to secure, move or insulate one component at a time and test drive the vehicle. Also, engine RPM or load can be changed to isolate the noise. Repairs can usually be made by moving, adjusting, securing, or insulating the component causing the noise.

SQUEAK AND RATTLE TROUBLE DIAGNOSES

< SYMPTOM DIAGNOSIS >

Diagnostic Worksheet

INFOID:000000006921817

Dear Customer:

We are concerned about your satisfaction with your vehicle. Repairing a squeak or rattle sometimes can be very difficult. To help us fix your vehicle right the first time, please take a moment to note the area of the vehicle where the squeak or rattle occurs and under what conditions. You may be asked to take a test drive with a service advisor or technician to ensure we confirm the noise you are hearing.

SQUEAK & RATTLE DIAGNOSTIC WORKSHEET

I. WHERE DOES THE NOISE COME FROM? (circle the area of the vehicle)

The illustrations are for reference only, and may not reflect the actual configuration of your vehicle.

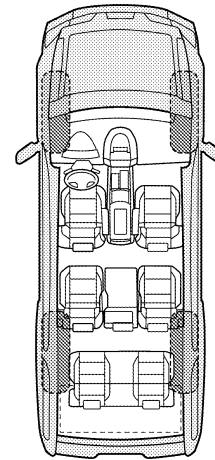
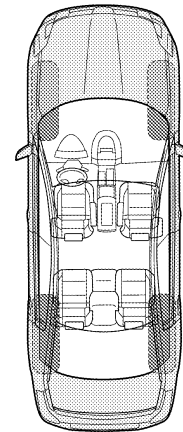

Continue to page 2 of the worksheet and briefly describe the location of the noise or rattle. In addition, please indicate the conditions which are present when the noise occurs.

A
B
C
D
E
F
G
H
I
IP
K
L
M
N
O
P

SQUEAK AND RATTLE TROUBLE DIAGNOSES

< SYMPTOM DIAGNOSIS >

SQUEAK & RATTLE DIAGNOSTIC WORKSHEET - page 2

Briefly describe the location where the noise occurs:

II. WHEN DOES IT OCCUR? (please check the boxes that apply)

- | | |
|---|--|
| <input type="checkbox"/> Anytime | <input type="checkbox"/> After sitting out in the rain |
| <input type="checkbox"/> 1st time in the morning | <input type="checkbox"/> When it is raining or wet |
| <input type="checkbox"/> Only when it is cold outside | <input type="checkbox"/> Dry or dusty conditions |
| <input type="checkbox"/> Only when it is hot outside | <input type="checkbox"/> Other: |

III. WHEN DRIVING:

- Through driveways
- Over rough roads
- Over speed bumps
- Only about ____ mph
- On acceleration
- Coming to a stop
- On turns: left, right or either (circle)
- With passengers or cargo
- Other: _____
- After driving ____ miles or ____ minutes

IV. WHAT TYPE OF NOISE

- Squeak (like tennis shoes on a clean floor)
- Creak (like walking on an old wooden floor)
- Rattle (like shaking a baby rattle)
- Knock (like a knock at the door)
- Tick (like a clock second hand)
- Thump (heavy muffled knock noise)
- Buzz (like a bumble bee)

TO BE COMPLETED BY DEALERSHIP PERSONNEL

Test Drive Notes:

	YES	NO	Initials of person performing
Vehicle test driven with customer	<input type="checkbox"/>	<input type="checkbox"/>	_____
- Noise verified on test drive	<input type="checkbox"/>	<input type="checkbox"/>	_____
- Noise source located and repaired	<input type="checkbox"/>	<input type="checkbox"/>	_____
- Follow up test drive performed to confirm repair	<input type="checkbox"/>	<input type="checkbox"/>	_____

VIN: _____ Customer Name _____
W.O.# _____ Date: _____

This form must be attached to Work Order

LATA0071E

INSTRUMENT PANEL ASSEMBLY

< REMOVAL AND INSTALLATION >

REMOVAL AND INSTALLATION

INSTRUMENT PANEL ASSEMBLY

Exploded View

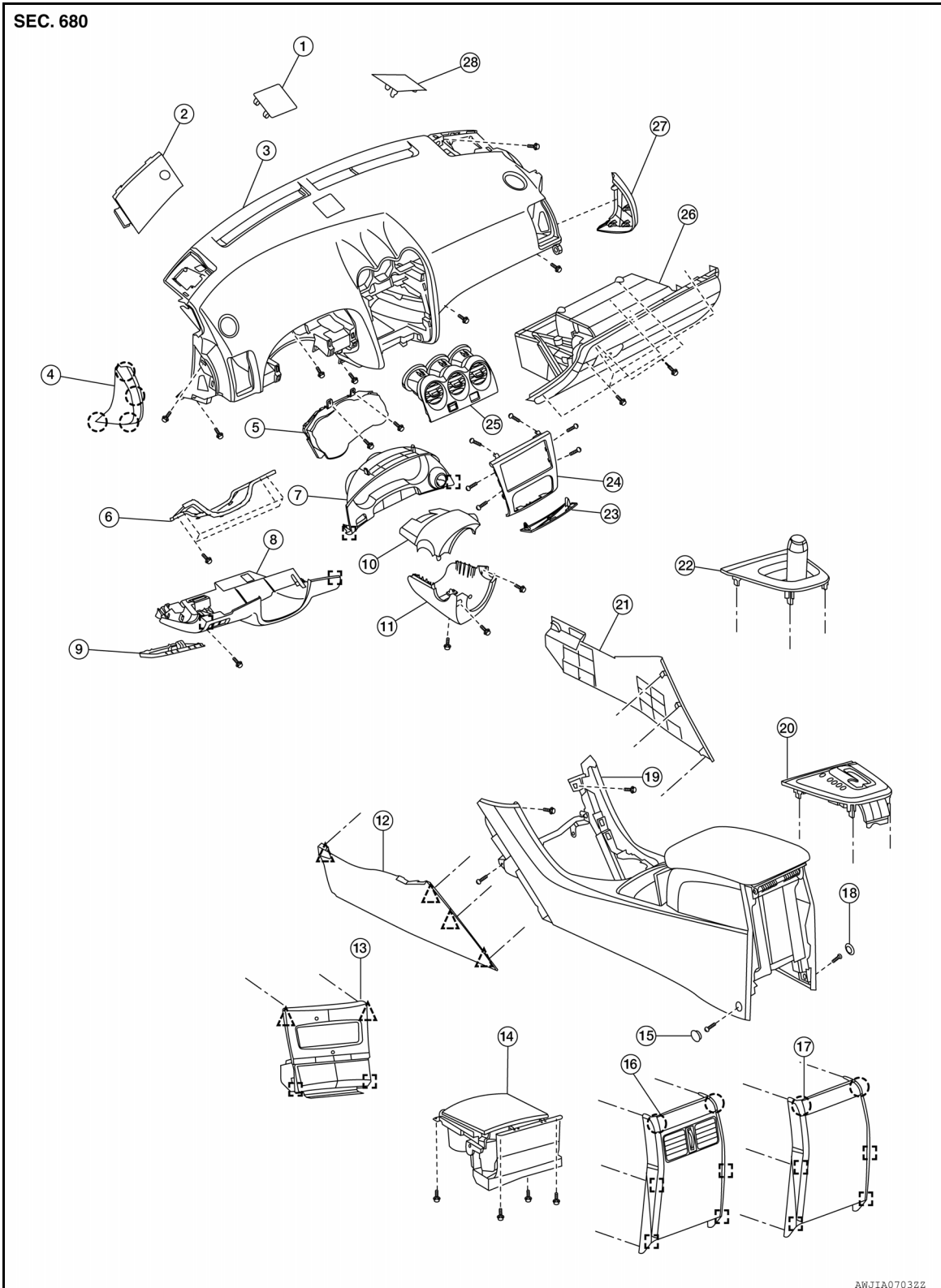

INFOID:000000006391398



A
B
C
D
E
F
G
H
I
IP
K
L
M
N
O
P

INSTRUMENT PANEL ASSEMBLY

< REMOVAL AND INSTALLATION >

- | | | |
|--|--|--|
| 1. Center speaker grille | 2. Tweeter speaker grille (LH) | 3. Instrument panel |
| 4. Instrument side finisher (LH) | 5. Combination meter | 6. Lower knee protector (LH) |
| 7. Cluster lid A | 8. Instrument lower cover (LH) | 9. Fuse block cover |
| 10. Steering column cover upper | 11. Steering column cover lower | 12. Console side finisher (LH) |
| 13. Finisher/storage bin | 14. Cup holder | 15. Console screw cover (LH) |
| 16. Console rear finisher (with rear duct) | 17. Console rear finisher (without rear duct) | 18. Console screw cover (RH) |
| 19. Console | 20. CVT finisher | 21. Console side finisher (RH) |
| 22. M/T finisher | 23. Cluster lid D | 24. Cluster lid C |
| 25. Center ventilator grilles | 26. Glove box assembly | 27. Instrument side finisher (RH) |
| 28. Tweeter speaker grille (RH) |  Clip |  Metal clip |
-  Pawl

Removal and Installation - Instrument Panel

INFOID:000000006921821

CAUTION:

- Be careful not to scratch instrument panel pad and other parts.
- Never tamper with or force air bag lid open, as this may adversely affect air bag performance.
- Before servicing, turn ignition switch OFF, disconnect both battery terminals and wait at least three minutes.

REMOVAL

1. Disconnect both the negative and positive battery terminals, then wait at least three minutes.
2. Remove the front pillar finishers (RH/LH). Refer to [INT-44. "Removal and Installation"](#) (Coupe) or [INT-18. "Removal and Installation"](#) (Sedan).
3. Remove the steering wheel. Refer to [ST-13. "Removal and Installation"](#).
4. Remove the front kicking plates (RH/LH) and dash side lower finishers (RH/LH). Refer to [INT-44. "Removal and Installation"](#) (Coupe) or [INT-18. "Removal and Installation"](#) (Sedan).
5. Remove the center console. Refer to [IP-14. "Removal and Installation"](#).
6. Remove the cluster lid A. Refer to [IP-16. "Removal and Installation"](#).
7. Remove the combination meter. Refer to [MWI-139. "Removal and Installation"](#).
8. Remove the glove box assembly. Refer to [IP-20. "Removal and Installation"](#).
9. Remove the spiral cable. Refer to [SR-8. "Removal and Installation"](#).
10. Remove the combination switch. Refer to [EXL-216. "Removal and Installation"](#).
11. Remove cluster lid C. Refer to [IP-16. "Removal and Installation"](#).
12. Remove the audio unit. Refer to [AV-51. "Removal and Installation"](#) (Base Audio), [AV-197. "Removal and Installation"](#) (Bose Audio Without Navigation) or [AV-410. "Removal and Installation"](#) (Bose Audio With Navigation).
13. Remove the front tweeter speakers (RH/LH) and center speaker, if equipped. Refer to [AV-52. "Removal and Installation"](#) (Front tweeter - Base Audio), [AV-201. "Removal and Installation"](#) (Front Tweeter - Bose Audio Without Navigation) or [AV-414. "Removal and Installation"](#) (Front Tweeter - Bose Audio With Navigation) and [AV-202. "Removal and Installation"](#) (Center Speaker - Bose Audio Without Navigation) or [AV-415. "Removal and Installation"](#) (Center Speaker - Bose Audio With Navigation).
14. Remove the passenger air bag bolt (A).

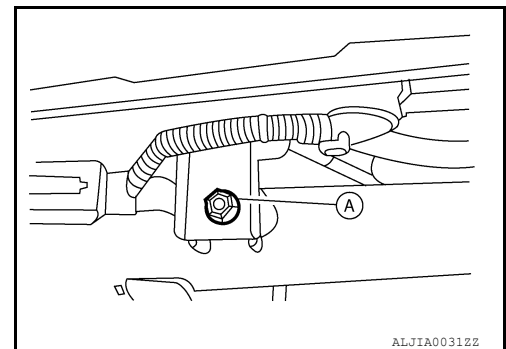

ALJIA00312Z

INSTRUMENT PANEL ASSEMBLY

< REMOVAL AND INSTALLATION >

15. Remove the remaining instrument panel screws (A).

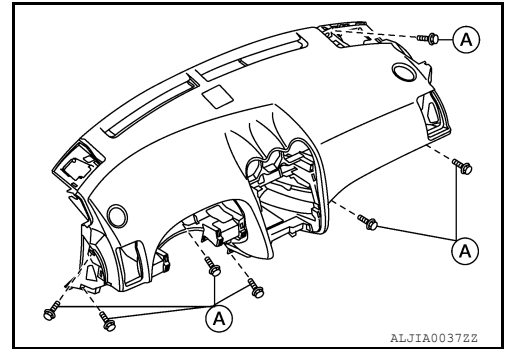

16. Disconnect the audio harness connector located near the RH windshield pillar.
17. Lift the instrument panel high enough in order to disconnect all the necessary harness connectors, then remove the instrument panel.

INSTALLATION

Installation is in the reverse order of removal.

- If replacing the Instrument panel transfer all the necessary parts to the new instrument panel.

Removal and Installation - Steering Column Covers

INFOID:000000006921822

REMOVAL

1. Remove the instrument lower panel LH. Refer to [IP-19, "Removal and Installation"](#).
2. Remove the steering column cover screws (A), then remove the steering column upper (1) and lower (2) covers.

NOTE:

Shown with steering wheel removed for clarity. If necessary, rotate steering wheel to access steering column cover screws (A).

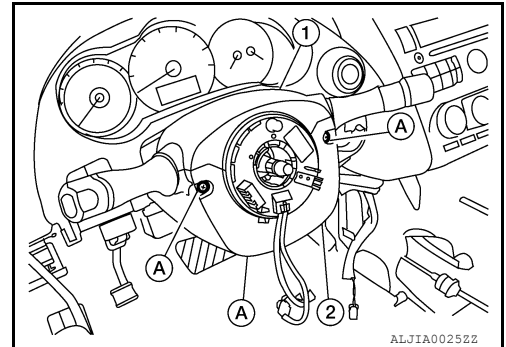

INSTALLATION

Installation is in the reverse order of removal.

CENTER CONSOLE ASSEMBLY

< REMOVAL AND INSTALLATION >

CENTER CONSOLE ASSEMBLY

Removal and Installation

INFOID:00000006927737

REMOVAL

CAUTION:

Whenever a suitable tool is used, always wrap a cloth around the end of the tool to protect components from damage.

1. Remove the CVT or MT finisher. Refer to [IP-21, "Removal and Installation"](#) (CVT) or [IP-11, "Exploded View"](#) (MT).
2. Release the pawls using a suitable tool and then remove cluster lid D (1).
○: Pawl

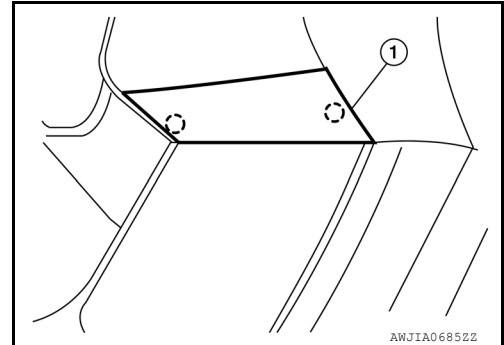

3. Release the clips using a suitable tool, then remove the finisher/storage bin.
4. Remove the instrument lower panel LH. Refer to [IP-19, "Removal and Installation"](#).
5. Remove the console side finishers (RH/LH).
6. Remove the console upper screws (A).

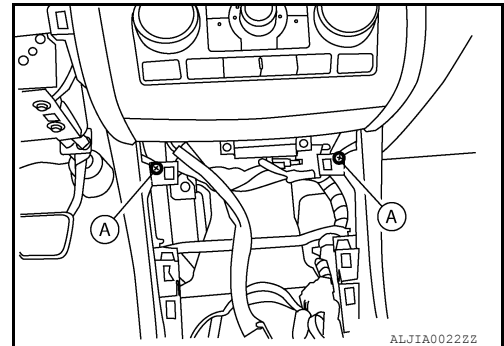

7. Remove the console side screws (A).

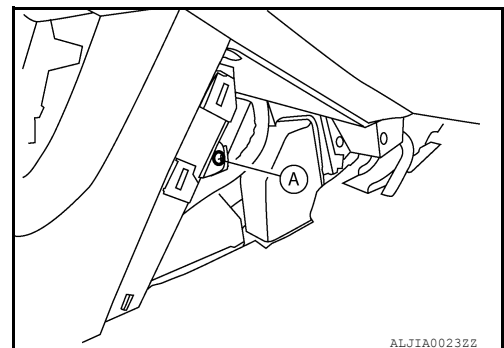

8. Position the front seats (RH/LH) forward.

CENTER CONSOLE ASSEMBLY

< REMOVAL AND INSTALLATION >

9. Remove the console rear screw covers (RH/LH).
10. Remove the console rear screw (A) from each side (RH/LH).
11. Disconnect necessary harness connectors, then remove the console assembly.

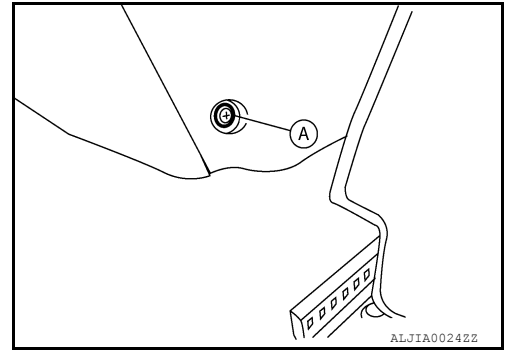

INSTALLATION

Installation is in the reverse order of removal.

A
B
C
D
E
F
G
H
I
IP
K
L
M
N
O
P

CLUSTER LID A

< REMOVAL AND INSTALLATION >

CLUSTER LID A

Removal and Installation

INFOID:000000006927738

REMOVAL

1. Remove instrument lower panel LH. Refer to [IP-19. "Removal and Installation"](#).

2. Release cluster lid A clips and pawls, then pull cluster lid A rearward.

NOTE:

Shown with steering wheel removed for clarity.

□: Metal clip

○: Pawl

3. Disconnect the push button ignition switch and function select switch connectors, then remove cluster lid A (1).

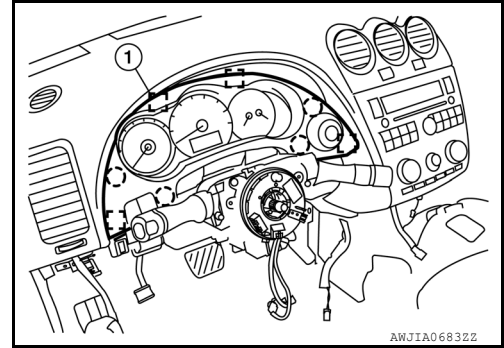

INSTALLATION

Installation is in the reverse order of removal.

CLUSTER LID C

< REMOVAL AND INSTALLATION >

CLUSTER LID C

Removal and Installation

INFOID:000000006921825

REMOVAL

CAUTION:

Whenever a suitable tool is used, always wrap a cloth around the end of the tool to protect components from damage.

1. Remove the center ventilator grilles. Refer to [VTL-25. "CENTER VENTILATOR GRILLES : Removal and Installation"](#).

2. Release the pawls using a suitable tool and remove cluster lid D (1).

⊖: Pawl

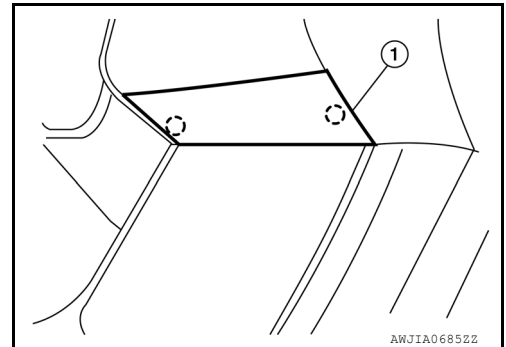

3. Remove the CVT or M/T finisher. Refer to [IP-21. "Removal and Installation" \(CVT\)](#) or [IP-11. "Exploded View" \(M/T\)](#).

4. Using a suitable tool, release the clips, then remove the finisher/storage bin.

5. Remove the storage box screws (B), then remove the storage box (1), if equipped.

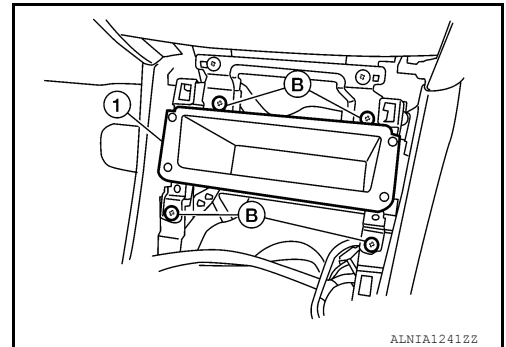

6. Remove the storage box bracket screws (C), then remove the storage box bracket (1), if equipped.

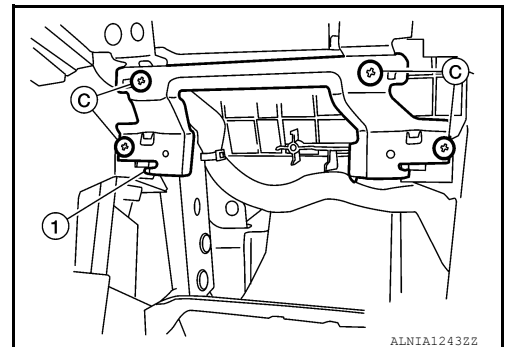

A
B
C
D
E
F
G
H
I
IP
K
L
M
N
O
P

CLUSTER LID C

< REMOVAL AND INSTALLATION >

7. Remove cluster lid C upper screws (A).

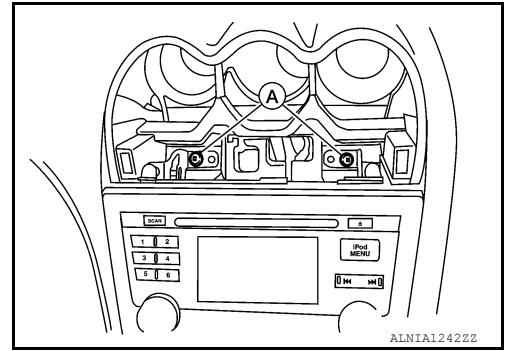

8. Remove cluster lid C lower screws (A), then pull cluster lid C outward.

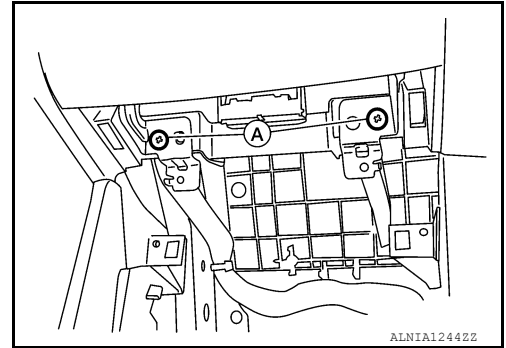

9. Disconnect the audio unit connectors.
10. Disconnect the front air control unit connector.
11. Disconnect the harness connectors.
12. Remove the audio unit from cluster lid C if necessary. Refer to [AV-51, "Removal and Installation"](#) (Base Audio), [AV-197, "Removal and Installation"](#) (Bose Audio Without Navigation) or [AV-410, "Removal and Installation"](#) (Bose Audio With Navigation).

INSTALLATION

Installation is in the reverse order of removal.

INSTRUMENT LOWER PANEL LH

< REMOVAL AND INSTALLATION >

INSTRUMENT LOWER PANEL LH

Removal and Installation

INFOID:000000006921826

REMOVAL

1. Using a suitable tool, gently remove the instrument side finisher (LH) (1).

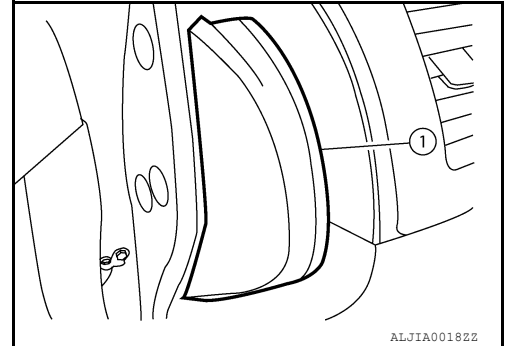

2. Open the fuse block cover and remove the instrument lower panel LH screw (A).
3. Release instrument lower panel LH clips and pawls, then pull instrument lower panel LH (1) downward.
□: Metal clip
○: Pawl
4. Disconnect the aspirator hose and harness connectors, then remove the instrument lower panel LH (1).

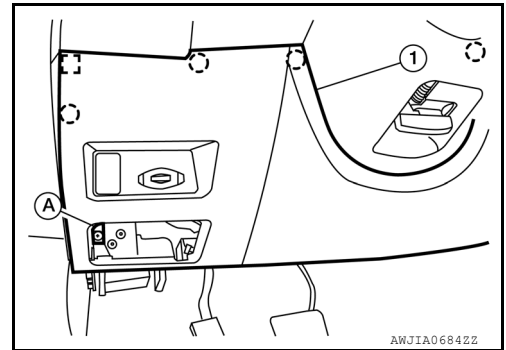

INSTALLATION

Installation is in the reverse order of removal.

A

B

C

D

E

F

G

H

I

IP

K

L

M

N

O

P

GLOVE BOX ASSEMBLY

< REMOVAL AND INSTALLATION >

GLOVE BOX ASSEMBLY

Removal and Installation

INFOID:000000006921827

REMOVAL

1. Using a suitable tool, gently remove the instrument side finisher (RH).
2. Open the glove box door (1), remove the glove box assembly screws (A).

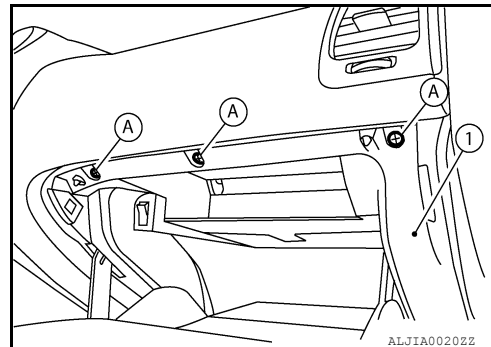

3. Remove the glove box assembly lower screws (A).

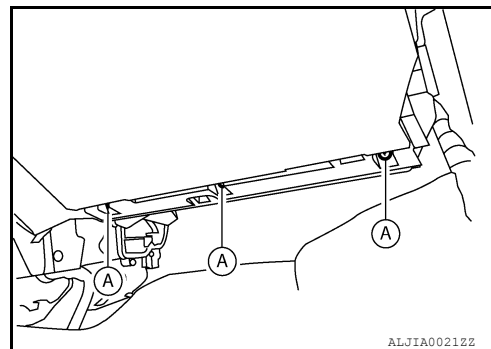

4. Disconnect the trunk switch and glove box lamp connectors, then remove the glove box assembly.

INSTALLATION

Installation is in the reverse order of removal.

CVT FINISHER

< REMOVAL AND INSTALLATION >

CVT FINISHER

Removal and Installation

INFOID:000000006921828

REMOVAL

CAUTION:

Whenever a suitable tool is used, always wrap a cloth around the end of the tool to protect components from damage.

1. Place the shift selector (5) into the drive (D) position.
2. Remove the shift selector handle (1).
 - a. Using a suitable tool, release the shift selector handle cover (3) from the base of the shift selector handle (1).
 - b. Remove the shift selector handle clip (2).
 - c. Pull upward and remove the shift selector handle (1).
3. Release the clips using a suitable tool, then lift the CVT finisher (4) upward.
4. Remove the CVT finisher illumination bulb from the CVT finisher and remove the CVT finisher (4).

△: Clip

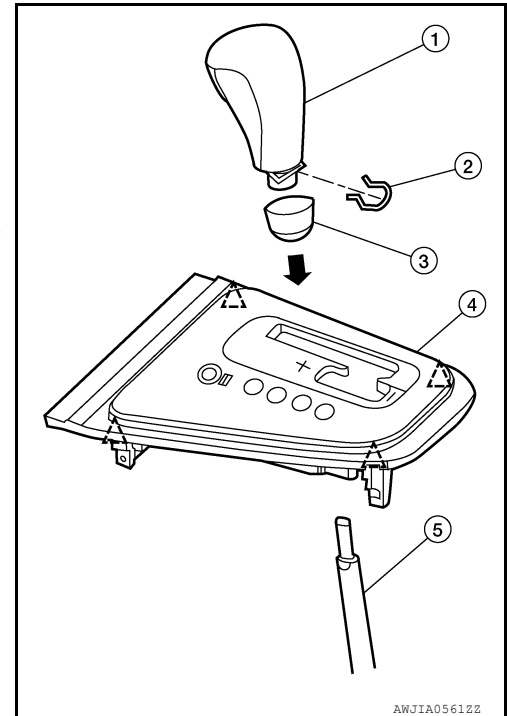

INSTALLATION

Installation is in the reverse order of removal.

A
B
C
D
E
F
G
H
I
IP
K
L
M
N
O
P

CENTER CONSOLE ASSEMBLY

< UNIT DISASSEMBLY AND ASSEMBLY >

UNIT DISASSEMBLY AND ASSEMBLY

CENTER CONSOLE ASSEMBLY

Exploded View

INFOID:000000006391402

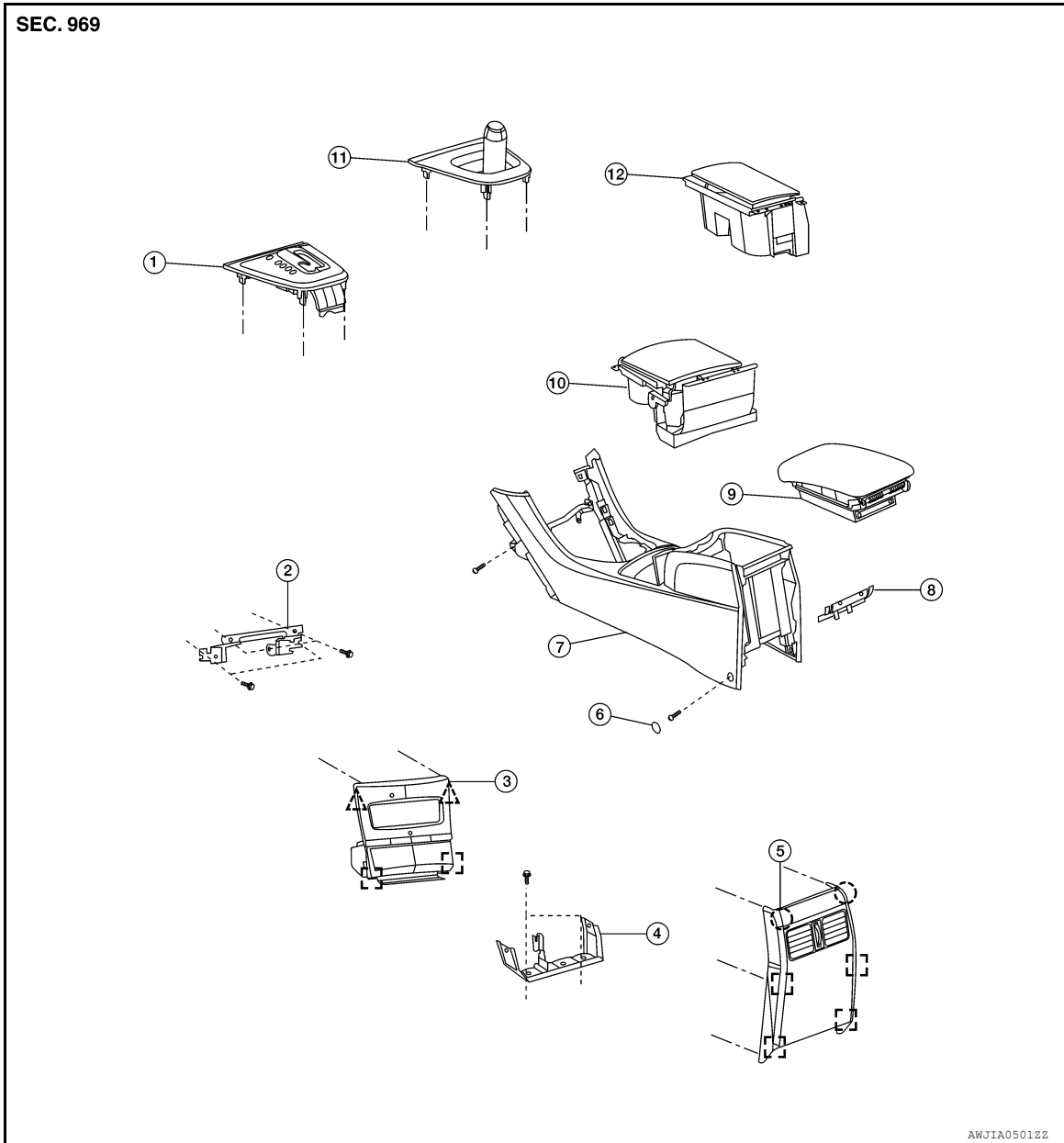

- | | | |
|--------------------------|---------------------------------|-----------------------------|
| 1. CVT finisher | 2. Finisher/storage bin bracket | 3. Finisher/storage bin |
| 4. Console floor bracket | 5. Console rear finisher | 6. Console screw cover (LH) |
| 7. Console | 8. Console lid assembly bracket | 9. Console lid assembly |
| 10. Cup holder CVT | 11. M/T finisher | 12. Cup holder M/T |
| Clip | Pawl | Metal clip |

Disassembly and Assembly

INFOID:000000006391403

DISASSEMBLY

1. Remove the console assembly. Refer to [IP-14, "Removal and Installation"](#).
2. Remove the cup holder screws, then remove the cup holder.

CENTER CONSOLE ASSEMBLY

< UNIT DISASSEMBLY AND ASSEMBLY >

3. Remove the console lid screws, then remove the console lid assembly. A
4. Remove the console rear finisher. A
5. Remove the console lid assembly bracket. A
6. Remove the power socket from the console. Refer to [PWO-8. "Removal and Installation"](#). B
7. Remove the USB connector (if equipped) from the console. Refer to [AV-200. "Removal and Installation"](#) (BOSE AUDIO Without NAVIGATION) or [AV-412. "Removal and Installation"](#) (BOSE AUDIO With NAVIGATION). B

ASSEMBLY

Assembly is in the reverse order of disassembly. C

D

E

F

G

H

I

IP

K

L

M

N

O

P