

SECTION **CHG**  
CHARGING SYSTEM

A  
B  
C  
D  
E  
F  
G  
H  
I  
J  
K  
L  
CHG  
N  
O  
P

CONTENTS

<b>BASIC INSPECTION</b> .....	2	<b>S TERMINAL CIRCUIT</b> .....	16
<b>DIAGNOSIS AND REPAIR WORKFLOW</b> .....	2	Description .....	16
Work Flow (With EXP-800 NI or GR8-1200 NI) .....	2	Diagnosis Procedure .....	16
Work Flow (Without EXP-800 NI or GR8-1200 NI).....	5	<b>WIRING DIAGRAM</b> .....	17
<b>SYSTEM DESCRIPTION</b> .....	8	<b>CHARGING SYSTEM</b> .....	17
<b>CHARGING SYSTEM</b> .....	8	Wiring Diagram .....	17
System Diagram .....	8	<b>SYMPTOM DIAGNOSIS</b> .....	22
System Description .....	8	<b>CHARGING SYSTEM</b> .....	22
Component Description .....	8	Symptom Table .....	22
<b>POWER GENERATION VOLTAGE VARIABLE CONTROL SYSTEM</b> .....	9	<b>PRECAUTION</b> .....	23
System Diagram .....	9	<b>PRECAUTIONS</b> .....	23
System Description .....	9	Precaution for Supplemental Restraint System (SRS) "AIR BAG" and "SEAT BELT PRE-TENSIONER" .....	23
Component Description .....	9	Precaution Necessary for Steering Wheel Rotation After Battery Disconnect .....	23
<b>DTC/CIRCUIT DIAGNOSIS</b> .....	10	Precaution for Power Generation Voltage Variable Control System .....	24
<b>CHARGING SYSTEM PRELIMINARY INSPECTION</b> .....	10	<b>PREPARATION</b> .....	25
Diagnosis Procedure .....	10	<b>PREPARATION</b> .....	25
<b>POWER GENERATION VOLTAGE VARIABLE CONTROL SYSTEM OPERATION INSPECTION</b> .....	11	Special Service Tool .....	25
Diagnosis Procedure .....	11	Commercial Service Tool .....	25
<b>B TERMINAL CIRCUIT</b> .....	12	<b>REMOVAL AND INSTALLATION</b> .....	26
Description .....	12	<b>GENERATOR</b> .....	26
Diagnosis Procedure .....	12	Removal and Installation .....	26
<b>L TERMINAL CIRCUIT (OPEN)</b> .....	13	<b>SERVICE DATA AND SPECIFICATIONS (SDS)</b> .....	29
Description .....	13	<b>SERVICE DATA AND SPECIFICATIONS (SDS)</b> .....	29
Diagnosis Procedure .....	13	Generator .....	29
<b>L TERMINAL CIRCUIT (SHORT)</b> .....	15		
Description .....	15		
Diagnosis Procedure .....	15		

# DIAGNOSIS AND REPAIR WORKFLOW

< BASIC INSPECTION >

---

## BASIC INSPECTION

### DIAGNOSIS AND REPAIR WORKFLOW

Work Flow (With EXP-800 NI or GR8-1200 NI)

INFOID:000000007422128

#### CHARGING SYSTEM DIAGNOSIS WITH EXP-800 NI OR GR8-1200 NI

To test the charging system, use the following special service tools:

- EXP-800 NI Battery and electrical diagnostic analyzer
- GR8-1200 NI Multitasking battery and electrical diagnostic station

**NOTE:**

Refer to the applicable Instruction Manual for proper charging system diagnosis procedures.

# DIAGNOSIS AND REPAIR WORKFLOW

< BASIC INSPECTION >

## OVERALL SEQUENCE

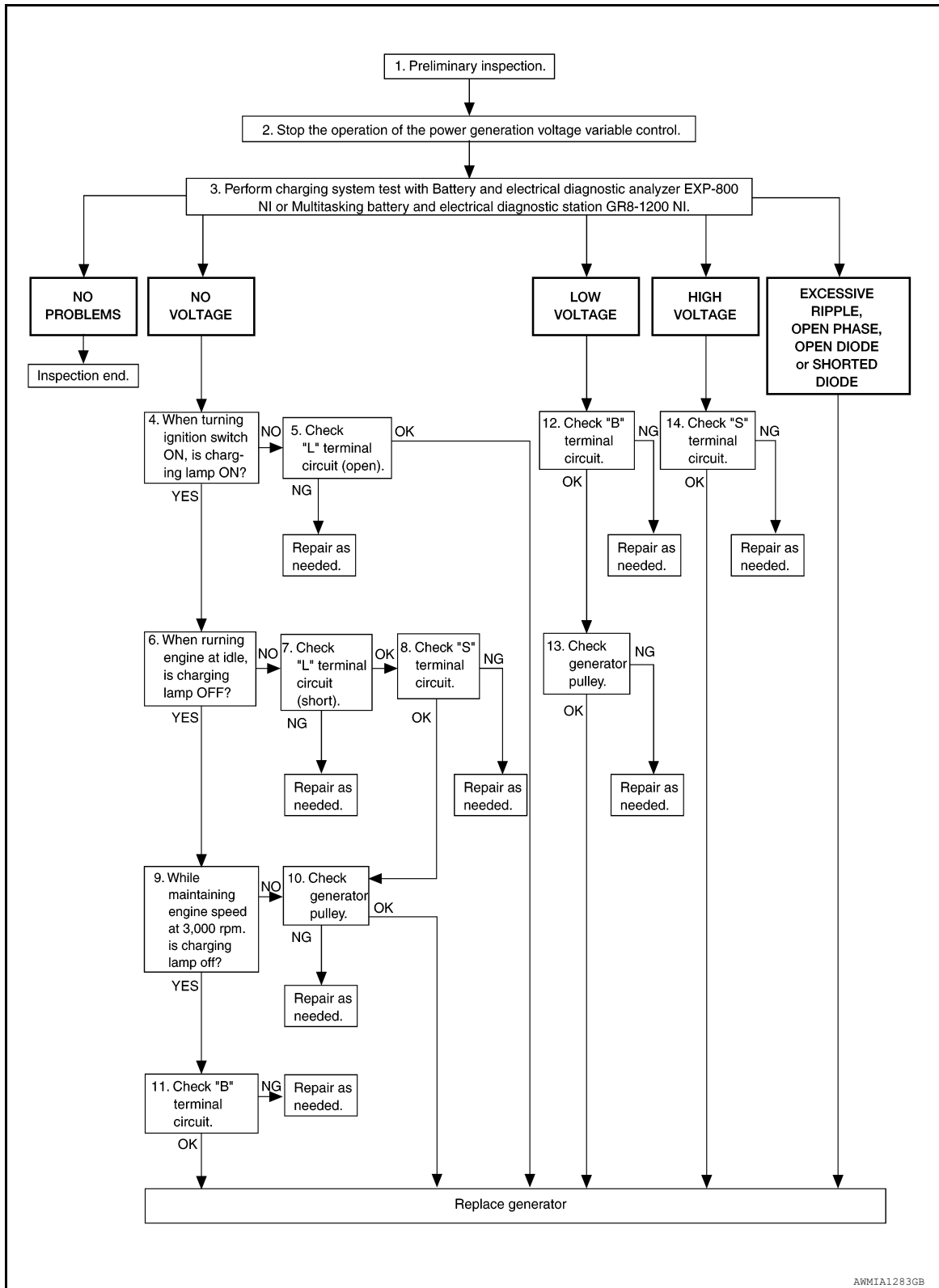

### DETAILED FLOW

#### NOTE:

To ensure a complete and thorough diagnosis, the battery, stator and generator test segments must be done as a set from start to finish.

#### 1. PRELIMINARY INSPECTION

Perform the preliminary inspection. Refer to [CHG-10. "Diagnosis Procedure"](#).

A  
B  
C  
D  
E  
F  
G  
H  
I  
J  
K  
L  
CHG  
N  
O  
P

# DIAGNOSIS AND REPAIR WORKFLOW

## < BASIC INSPECTION >

---

>> GO TO 2.

### 2. STOP POWER GENERATION VOLTAGE VARIABLE CONTROL SYSTEM

---

Stop the operation of the power generation voltage variable control in either of the following procedures.

- After selecting “ENGINE” using CONSULT, set the DUTY value of “ALTERNATOR DUTY” to 0 % by selecting “ALTERNATOR DUTY” of “Active Test”. Continue “Active Test” until the end of inspection. (When the DUTY value is 0 or 100 %, the normal power generation is performed according to the characteristic of the IC regulator of the generator.)
- Turn the ignition switch OFF, and disconnect the battery current sensor connector. [However, DTC (P1550–P1554) of the engine might remain. After finishing the inspection, connect the battery current sensor connector and erase the self diagnosis results history of the engine using CONSULT.]

>> GO TO 3.

### 3. DIAGNOSIS WITH EXP-800 NI OR GR8-1200 NI

---

Perform the charging system test using Multitasking battery and electrical diagnostic station GR8-1200 NI or Battery and electrical diagnostic analyzer EXP-800 NI. Refer to the applicable Instruction Manual for proper testing procedures.

#### Test result

NO PROBLEMS>>Charging system is normal and will also show “DIODE RIPPLE” test result.

NO VOLTAGE>>GO TO 4.

LOW VOLTAGE>>GO TO 12.

HIGH VOLTAGE>>GO TO 14.

EXCESSIVE RIPPLE, OPEN PHASE, OPEN DIODE or SHORTED DIODE>>Replace the generator. Refer to [CHG-26, "Removal and Installation"](#). Perform “DIODE RIPPLE” test again using Multitasking battery and electrical diagnostic station GR8-1200 NI or Battery and electrical diagnostic analyzer EXP-800 NI to confirm repair.

### 4. INSPECTION WITH CHARGE WARNING LAMP (IGNITION SWITCH IS ON)

---

Turn the ignition switch ON.

Does the charge warning lamp illuminate?

YES >> GO TO 6.

NO >> GO TO 5.

### 5. “L” TERMINAL CIRCUIT (OPEN) INSPECTION

---

Check “L” terminal circuit (open). Refer to [CHG-13, "Diagnosis Procedure"](#).

Is the “L” terminal circuit normal?

YES >> Replace generator. Refer to [CHG-26, "Removal and Installation"](#).

NO >> Repair as needed.

### 6. INSPECTION WITH CHARGE WARNING LAMP (IDLING)

---

Start the engine and run it at idle.

Does the charge warning lamp turn OFF?

YES >> GO TO 9.

NO >> GO TO 7.

### 7. “L” TERMINAL CIRCUIT (SHORT) INSPECTION

---

Check “L” terminal circuit (short). Refer to [CHG-15, "Diagnosis Procedure"](#).

Is the “L” terminal circuit normal?

YES >> GO TO 8.

NO >> Repair as needed.

### 8. “S” TERMINAL CIRCUIT INSPECTION

---

Check “S” terminal circuit. Refer to [CHG-16, "Diagnosis Procedure"](#).

Is the “S” terminal circuit normal?

YES >> GO TO 10.

# DIAGNOSIS AND REPAIR WORKFLOW

## < BASIC INSPECTION >

NO >> Repair as needed.

### 9. INSPECTION WITH CHARGE WARNING LAMP (ENGINE AT 3,000 RPM)

Increase and maintain the engine speed at 3,000 rpm.

Does the charge warning lamp remain off?

YES >> GO TO 11.

NO >> GO TO 10.

### 10. INSPECTION OF GENERATOR PULLEY

Check generator pulley. Refer to [EM-16. "Checking Drive Belts"](#) (QR25DE) or [EM-123. "Checking Drive Belts"](#) (VQ35DE).

Is generator pulley normal?

YES >> Replace generator. Refer to [CHG-26. "Removal and Installation"](#).

NO >> Repair as needed.

### 11. "B" TERMINAL CIRCUIT INSPECTION

Check "B" terminal circuit. Refer to [CHG-12. "Diagnosis Procedure"](#).

Is "B" terminal circuit normal?

YES >> Replace generator. Refer to [CHG-26. "Removal and Installation"](#).

NO >> Repair as needed.

### 12. "B" TERMINAL CIRCUIT INSPECTION

Check "B" terminal circuit. Refer to [CHG-12. "Diagnosis Procedure"](#).

Is "B" terminal circuit normal?

YES >> GO TO 13.

NO >> Repair as needed.

### 13. INSPECTION OF GENERATOR PULLEY

Check generator pulley. Refer to [EM-16. "Checking Drive Belts"](#) (QR25DE) or [EM-123. "Checking Drive Belts"](#) (VQ35DE).

Is generator pulley normal?

YES >> Replace generator. Refer to [CHG-26. "Removal and Installation"](#).

NO >> Repair as needed.

### 14. "S" TERMINAL CIRCUIT INSPECTION

Check "S" terminal circuit. Refer to [CHG-16. "Diagnosis Procedure"](#).

Is the "S" terminal circuit normal?

YES >> Replace generator. Refer to [CHG-26. "Removal and Installation"](#).

NO >> Repair as needed.

## Work Flow (Without EXP-800 NI or GR8-1200 NI)

INFOID:000000009325995

CHG

## OVERALL SEQUENCE

Before performing a generator test, make sure that the battery is fully charged. A 30-volt voltmeter and suitable test probes are necessary for the test.

- Before starting, inspect the fusible link.

# DIAGNOSIS AND REPAIR WORKFLOW

## < BASIC INSPECTION >

- Use fully charged battery.

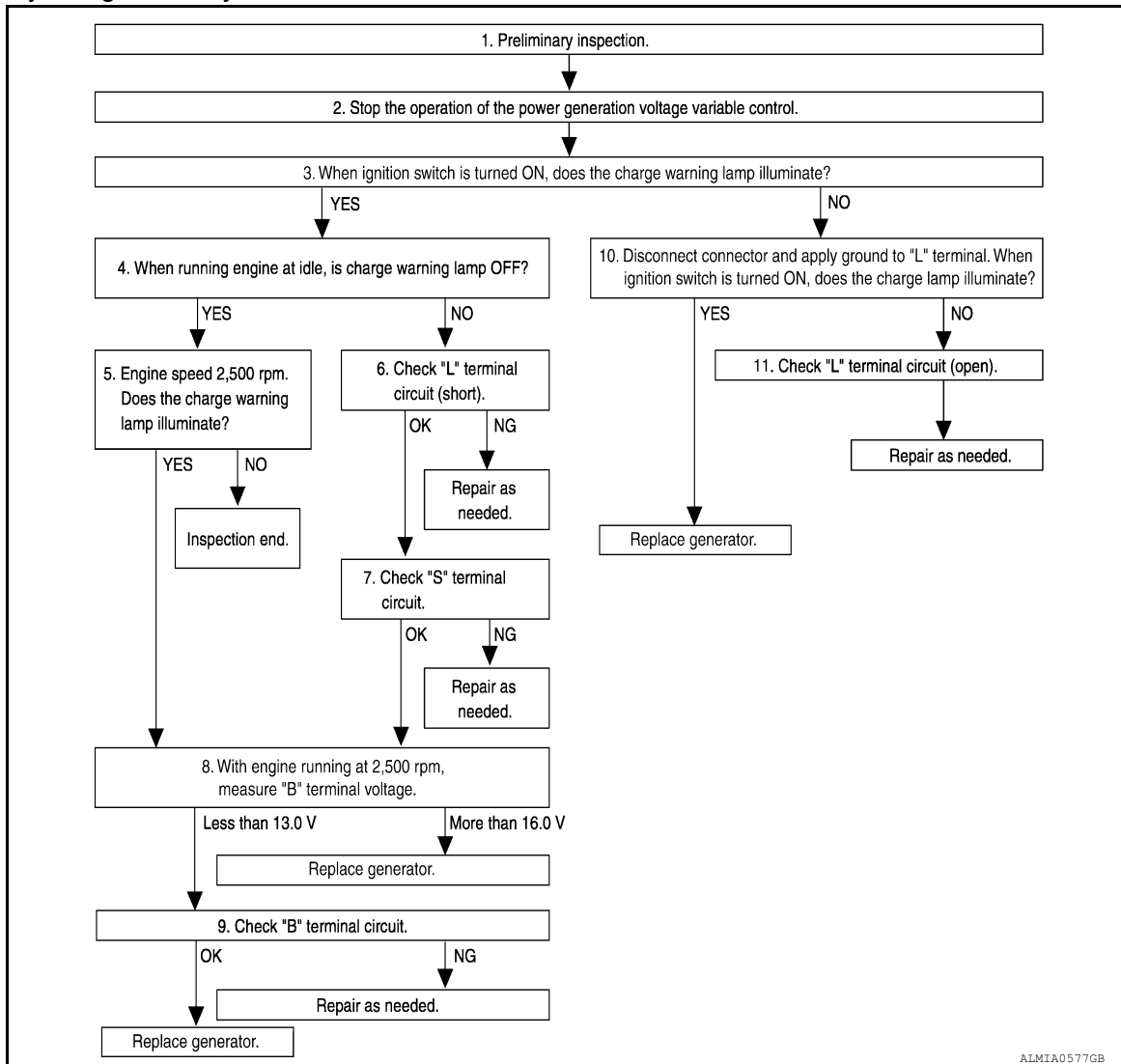

## DETAILED FLOW

### 1. PRELIMINARY INSPECTION

Perform the preliminary inspection. Refer to [CHG-10, "Diagnosis Procedure"](#).

>> GO TO 2.

### 2. STOP POWER GENERATION VOLTAGE VARIABLE CONTROL SYSTEM

Stop the operation of the power generation voltage variable control in either of the following procedures:

- After selecting "ENGINE" using CONSULT, set the DUTY value of "ALTERNATOR DUTY" to 0 % by selecting "ALTERNATOR DUTY" with "Active Test". Continue "Active Test" until the end of inspection. (When the DUTY value is 0 or 100 %, the normal power generation is performed according to the characteristic of the IC regulator of the generator.)
- Turn the ignition switch OFF, and disconnect the battery current sensor connector. [However, DTC (P1550 - P1554) of the engine might remain. After finishing the inspection, connect the battery current sensor connector and erase the self-diagnostic results history of the engine using CONSULT.]

>> GO TO 3.

### 3. INSPECTION WITH CHARGE WARNING LAMP (IGNITION SWITCH IS TURNED ON)

When ignition switch is turned ON.

Does the charge warning lamp illuminate?

# DIAGNOSIS AND REPAIR WORKFLOW

## < BASIC INSPECTION >

---

YES >> GO TO 4.  
NO >> GO TO 10.

A

### 4.INSPECTION WITH CHARGE WARNING LAMP (IDLING)

---

Start the engine and run it at idle

B

Does the charge warning lamp turn OFF?

YES >> GO TO 5.  
NO >> GO TO 6.

C

### 5.INSPECTION WITH CHARGE WARNING LAMP (ENGINE AT 2,500 RPM)

---

Increase and maintain the engine speed at 2,500 rpm.

D

Does the charge warning lamp illuminate?

YES >> GO TO 8.  
NO >> Inspection End.

E

### 6.“L” TERMINAL CIRCUIT (SHORT) INSPECTION

---

Check terminal “L” circuit for (short). Refer to [CHG-15, "Diagnosis Procedure"](#).

F

Is the inspection result normal?

YES >> GO TO 7.  
NO >> Repair as needed.

G

### 7.“S” TERMINAL CIRCUIT INSPECTION

---

Check terminal “S” circuit. Refer to [CHG-16, "Diagnosis Procedure"](#).

H

Is the inspection result normal?

YES >> GO TO 8.  
NO >> Repair as needed.

### 8.MEASURE “B” TERMINAL VOLTAGE

---

I

Start engine. With engine running at 2,500 rpm, measure “B” terminal voltage.

What voltage does the measurement result show?

J

Less than 13.0 V>>GO TO 9.  
More than 16.0 V>>Replace generator. Refer to [CHG-26, "Removal and Installation"](#).

### 9.“B” TERMINAL CIRCUIT INSPECTION

---

K

Check “B” terminal circuit. Refer to [CHG-12, "Diagnosis Procedure"](#).

Is the inspection result normal?

YES >> Replace generator. Refer to [CHG-26, "Removal and Installation"](#).  
NO >> Repair as needed.

L

### 10.INSPECTION WITH CHARGE WARNING LAMP (IGNITION SWITCH IS ON)

---

CHG

1. Disconnect generator connector and apply ground to “L” terminal.
2. Turn the ignition switch ON.

Does the charge warning lamp illuminate?

N

YES >> Replace generator. Refer to [CHG-26, "Removal and Installation"](#).  
NO >> GO TO 11.

### 11.CHECK “L” TERMINAL CIRCUIT (OPEN)

---

O

Check “L” terminal circuit (OPEN). Refer to [CHG-13, "Diagnosis Procedure"](#).

>> Repair as needed.

P

# CHARGING SYSTEM

< SYSTEM DESCRIPTION >

## SYSTEM DESCRIPTION

### CHARGING SYSTEM

#### System Diagram

INFOID:000000007422129

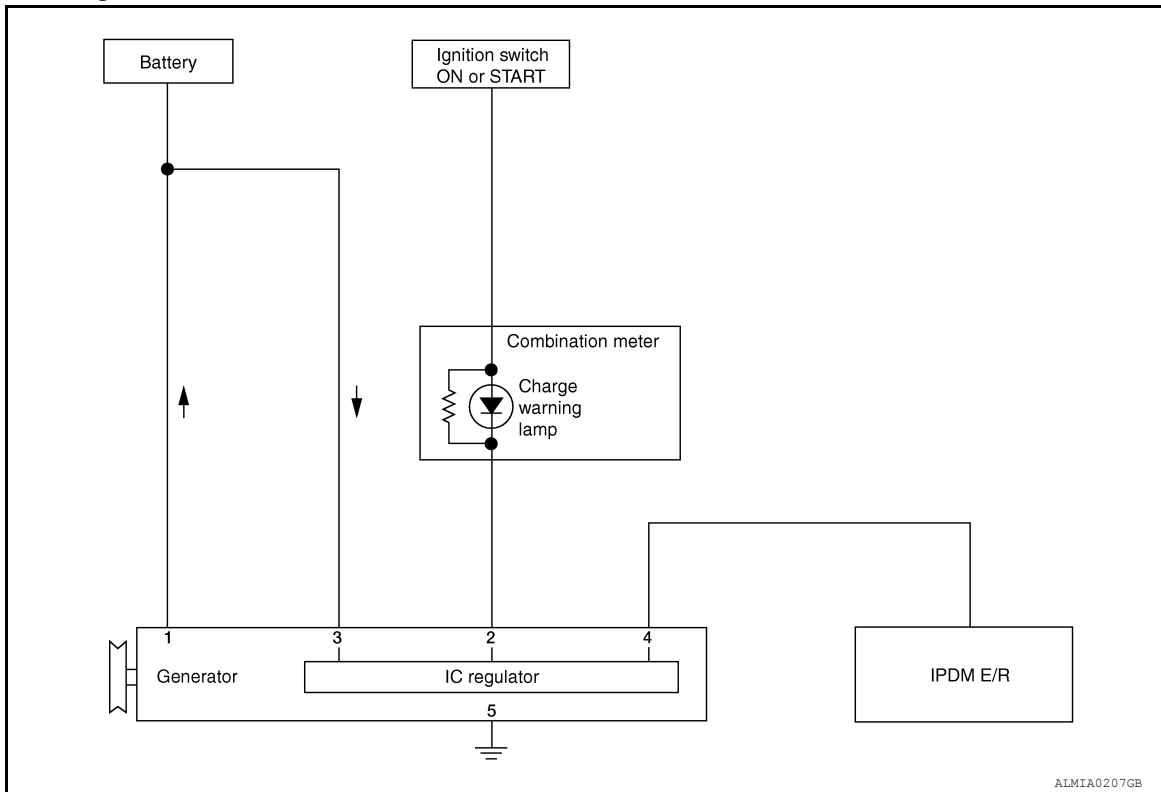

ALMIA0207GB

#### System Description

INFOID:000000007422130

The generator provides DC voltage to operate the vehicle's electrical system and to keep the battery charged. The voltage output is controlled by the IC regulator.

#### Component Description

INFOID:000000007422131

Component part		Description
Generator	Terminal "1"	Refer to <a href="#">CHG-12, "Description"</a> .
	Terminal "2"	Refer to <a href="#">CHG-13, "Description"</a> .
	Terminal "3"	Refer to <a href="#">CHG-16, "Description"</a> .
	Terminal "4"	Used for the power generation voltage variable control system. Refer to <a href="#">CHG-9, "System Description"</a> .
Combination meter (Charge warning lamp)		The IC regulator warning function activates to illuminate the charge warning lamp if any of the following symptoms occur while generator is operating: <ul style="list-style-type: none"> <li>Excessive voltage is produced.</li> <li>No voltage is produced.</li> </ul>
IPDM E/R		Used for the power generation voltage variable control system. Refer to <a href="#">CHG-9, "System Description"</a> .



# POWER GENERATION VOLTAGE VARIABLE CONTROL SYSTEM

< SYSTEM DESCRIPTION >

## POWER GENERATION VOLTAGE VARIABLE CONTROL SYSTEM

### System Diagram

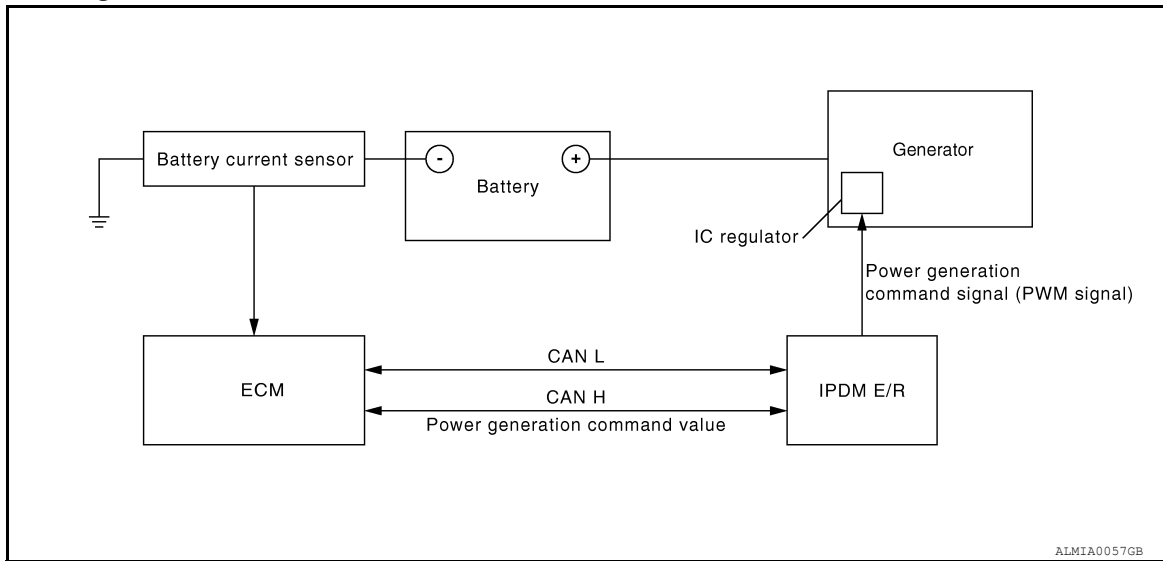

### System Description

Power generation variable voltage control system has been adopted. By varying the voltage to the generator, engine load due to power generation of the generator is reduced and fuel consumption is decreased. For more information, refer to [EC-239, "Description"](#).

**NOTE:**

When any malfunction is detected in the power generation variable voltage control system, power generation is performed according to the characteristic of the IC regulator in the generator.

### Component Description

Component part	Description
Battery current sensor	The battery current sensor is installed on the battery cable at the negative terminal. The battery current sensor detects the charging/discharging current of the battery and sends a voltage signal to the ECM according to the current value detected.
ECM	The battery current sensor detects the charging/discharging current of the battery. The ECM judges the battery condition based on this signal. The ECM judges whether to request more output via the power generation voltage variable control according to the battery condition. When performing the power generation voltage variable control, the ECM calculates the target power generation voltage according to the battery condition and sends the calculated value as the power generation command value to the IPDM E/R.
IPDM E/R	The IPDM E/R converts the received power generation command value into a pulse width modulated (PWM) command signal and sends it to the IC regulator.
Generator (IC regulator)	The IC regulator controls the power generation voltage by the target power generation voltage based on the received PWM command signal. When there is no PWM command signal, the generator performs the normal power generation according to the characteristic of the IC regulator.

# CHARGING SYSTEM PRELIMINARY INSPECTION

< DTC/CIRCUIT DIAGNOSIS >

## DTC/CIRCUIT DIAGNOSIS

### CHARGING SYSTEM PRELIMINARY INSPECTION

#### Diagnosis Procedure

INFOID:000000007422135

#### 1. CHECK BATTERY TERMINALS CONNECTION

Check if battery terminals are clean and tight.

Is the inspection result normal?

YES >> GO TO 2

NO >> Repair battery terminals connection. Confirm repair by performing complete Charging system test using EXP-800 NI or GR-8-1200 NI (if available). Refer to the applicable Instruction Manual for proper testing procedures.

#### 2. CHECK FUSE

Check for blown fuse and fusible link.

Unit	Power source (Power supply terminals)	Fuse or Fusible Link
Generator	Battery (terminal 3)	Fuse 29
	Battery (terminal 1)	Fusible Link A
Combination meter	Ignition switch ON (terminal 2)	Fuse 4

Is the inspection result normal?

YES >> GO TO 3

NO >> Be sure to eliminate cause of malfunction before installing new fuse or fusible link.

#### 3. CHECK GENERATOR GROUND TERMINAL CONNECTION

Check if connector E230 terminal 5 (generator ground harness) is clean and tight.

Is the inspection result normal?

YES >> GO TO 4

NO >> Repair connection.

#### 4. CHECK DRIVE BELT TENSION

Check drive belt tension. Refer to [EM-16, "Checking Drive Belts"](#) (QR25DE) or [EM-123, "Checking Drive Belts"](#) (VQ35DE).

Is the inspection result normal?

YES >> Inspection End.

NO >> Repair as needed.

# POWER GENERATION VOLTAGE VARIABLE CONTROL SYSTEM OPERATION INSPECTION

< DTC/CIRCUIT DIAGNOSIS >

## POWER GENERATION VOLTAGE VARIABLE CONTROL SYSTEM OPERATION INSPECTION

### Diagnosis Procedure

INFOID:000000007422136

Regarding Wiring Diagram information, refer to [CHG-17. "Wiring Diagram"](#).

#### CAUTION:

When performing this inspection, always use a charged battery that has completed the battery inspection. (When the charging rate of the battery is low, the response speed of the voltage change will become slow. This can cause an incorrect inspection.)

### 1. CHECK ELECTRICAL LOAD SIGNAL

Perform electrical load tests. Refer to [EC-239. "Component Function Check"](#).

Is the inspection result normal?

YES >> GO TO 2

NO >> Check applicable parts, and repair or replace corresponding parts.

### 2. CHECK HARNESS BETWEEN GENERATOR AND IPDM E/R

1. Turn ignition switch OFF.
2. Disconnect generator connector and IPDM E/R connector.
3. Check continuity between generator harness connector F7 (A) terminal 4 and IPDM E/R harness connector F10 (B) terminal 76.

**4 - 76**

**Continuity should exist**

4. Check continuity between generator harness connector F7 (A) terminal 4 and ground.

**4 - ground**

**Continuity should not exist**

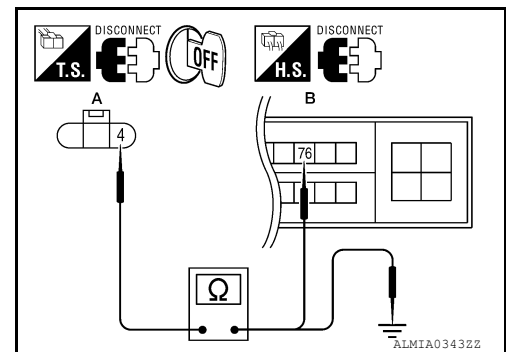

Is the inspection result normal?

YES >> Replace IPDM E/R. Refer to [PCS-45. "Removal and Installation"](#).

NO >> Repair harness or connector between IPDM E/R and generator.

A  
B  
C  
D  
E  
F  
G  
H  
I  
J  
K  
L

CHG

## B TERMINAL CIRCUIT

< DTC/CIRCUIT DIAGNOSIS >

### B TERMINAL CIRCUIT

#### Description

INFOID:000000007422137

The terminal "1" (B) circuit supplies power to charge the battery and operate the vehicles electrical system.

#### Diagnosis Procedure

INFOID:000000007422138

Regarding Wiring Diagram information, refer to [CHG-17, "Wiring Diagram"](#).

#### 1. CHECK TERMINAL "1" CONNECTION

1. Turn ignition switch OFF.
2. Check if terminal "1" is clean and tight.

Is the inspection result normal?

YES >> GO TO 2

NO >> Repair terminal "1" connection. Confirm repair by performing complete Charging system test using EXP-800 NI or GR8-1200 NI (if available). Refer to the applicable Instruction Manual for proper testing procedures.

#### 2. CHECK TERMINAL "1" CIRCUIT

Check voltage between generator connector F6 terminal 1 and ground.

**1 - ground**

**Battery voltage**

Is the inspection result normal?

YES >> GO TO 3.

NO >> Check harness for open between generator and fusible link.

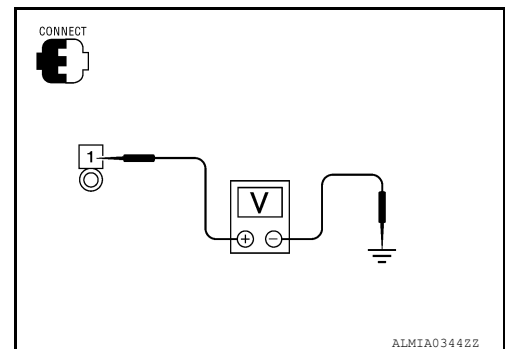

#### 3. CHECK TERMINAL "1" CONNECTION (VOLTAGE DROP TEST)

1. Start engine, then engine running at idle and warm.
2. Check voltage between battery positive terminal and generator connector F6 terminal 1.

**1 - B+**

**Less than 0.2V**

Is the inspection result normal?

YES >> Terminal "1" circuit is normal. Refer to [CHG-2, "Work Flow \(With EXP-800 NI or GR8-1200 NI\)"](#) or [CHG-5, "Work Flow \(Without EXP-800 NI or GR8-1200 NI\)"](#).

NO >> Check harness between battery and generator for high resistance.

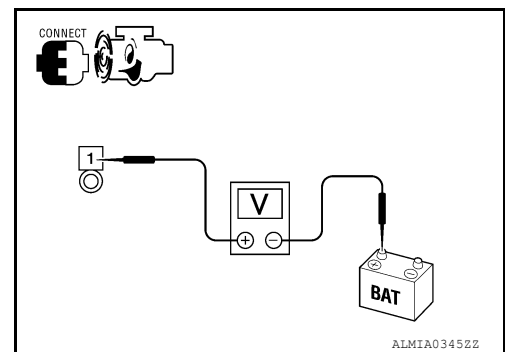

# L TERMINAL CIRCUIT (OPEN)

< DTC/CIRCUIT DIAGNOSIS >

## L TERMINAL CIRCUIT (OPEN)

### Description

INFOID:000000007422139

The "2" (L) terminal circuit controls the charge warning lamp. The charge warning lamp turns ON when the ignition switch is set to ON or START. When the generator is providing sufficient voltage with the engine running, the charge warning lamp turns OFF. If the charge warning lamp illuminates with the engine running, a malfunction is indicated.

### Diagnosis Procedure

INFOID:000000007422140

Regarding Wiring Diagram information. Refer to [CHG-17, "Wiring Diagram"](#).

#### 1. CHECK "L" TERMINAL CONNECTION

1. Turn ignition switch OFF.
2. Check if "L" terminal is clean and tight.

Is the inspection result normal?

YES >> GO TO 2.

NO >> Repair "L" terminal connection. Confirm repair by performing complete Charging system test using EXP-800 NI or GR8-1200 NI (if available). Refer to applicable Instruction Manual for proper testing procedures.

#### 2. CHECK "L" TERMINAL CIRCUIT (OPEN)

1. Disconnect the generator connector.
2. Apply ground to generator harness connector terminal.
3. Check condition of the charge warning lamp with the ignition switch in the ON position.

Generator		Ground	Condition	
Connector	Terminal		Ignition switch position	Charge warning lamp
F7	2		ON	Illuminate

Does it illuminate?

YES >> "L" terminal circuit is normal. Refer to [CHG-2, "Work Flow \(With EXP-800 NI or GR8-1200 NI\)"](#) or [CHG-5, "Work Flow \(Without EXP-800 NI or GR8-1200 NI\)"](#).

NO >> GO TO 3.

#### 3. CHECK HARNESS CONTINUITY (OPEN CIRCUIT)

1. Disconnect the battery cable from the negative terminal.
2. Disconnect the combination meter connector.
3. Check continuity between generator harness connector and combination meter harness connector.

Generator		Combination meter		Continuity
Connector	Terminal	Connector	Terminal	
F7	2	M24	25	Yes

Is the inspection result normal?

YES >> GO TO 4.

NO >> Repair or replace the harness or connectors.

#### 4. CHECK HARNESS CONTINUITY (OPEN CIRCUIT)

Check continuity between combination meter harness connector and fuse block (J/B).

Combination meter		Fuse box (J/B)		Continuity
Connector	Terminal	Connector	Terminal	
M24	2	M5	12M	Yes

A  
B  
C  
D  
E  
F  
G  
H  
I  
J  
K  
L

CHG

N  
O  
P

## L TERMINAL CIRCUIT (OPEN)

< DTC/CIRCUIT DIAGNOSIS >

Is the inspection result normal?

YES >> GO TO 5.

NO >> Repair or replace the harness or connectors.

### 5. CHECK POWER SUPPLY CIRCUIT

1. Connect the battery cable to the negative terminal.
2. Check voltage between combination meter harness connector and ground.

(+)		(-)	Condition	Voltage (Approx.)
Combination meter				
Connector	Terminal			
M24	2	Ground	When the ignition switch is in ON position	Battery voltage

Is the inspection result normal?

YES >> Replace the combination meter. Refer to [MWI-139. "Removal and Installation"](#).

NO >> Repair or replace the harness or connectors.

# L TERMINAL CIRCUIT (SHORT)

< DTC/CIRCUIT DIAGNOSIS >

## L TERMINAL CIRCUIT (SHORT)

### Description

INFOID:000000009325996

The terminal "2" (L) circuit controls the charge warning lamp. The charge warning lamp turns ON when the ignition switch is set to ON or START. When the generator is providing sufficient voltage with the engine running, the charge warning lamp turns off. If the charge warning lamp illuminates with the engine running, a malfunction is indicated.

### Diagnosis Procedure

INFOID:000000009325997

Regarding Wiring Diagram information, refer to [CHG-17, "Wiring Diagram"](#).

#### 1. CHECK "L" TERMINAL CIRCUIT (SHORT)

1. Turn ignition switch OFF.
2. Disconnect generator connector.
3. Turn ignition switch ON.

Does charge warning lamp illuminate?

YES >> GO TO 2.

NO >> Refer to [CHG-2, "Work Flow \(With EXP-800 NI or GR8-1200 NI\)"](#) or [CHG-5, "Work Flow \(Without EXP-800 NI or GR8-1200 NI\)"](#).

#### 2. CHECK HARNESS CONTINUITY (SHORT CIRCUIT)

1. Turn ignition switch OFF.
2. Disconnect the battery cable from the negative terminal.
3. Disconnect combination meter connector.
4. Check continuity between the combination meter harness connector and ground.

Combination meter		Ground	Continuity
Connector	Terminal		
M24	25		No

Is the inspection result normal?

YES >> Replace the combination meter. Refer to [MWI-139, "Removal and Installation"](#).

NO >> Repair or replace the harness or connectors.

A  
B  
C  
D  
E  
F  
G  
H  
I  
J  
K  
L

CHG

# S TERMINAL CIRCUIT

< DTC/CIRCUIT DIAGNOSIS >

## S TERMINAL CIRCUIT

### Description

INFOID:000000007422141

The output voltage of the generator is controlled by the IC regulator at terminal "3" (S) detecting the input voltage. Terminal "3" circuit detects the battery voltage to adjust the generator output voltage with the IC regulator.

### Diagnosis Procedure

INFOID:000000007422142

Regarding Wiring Diagram information, refer to [CHG-17, "Wiring Diagram"](#).

### 1. CHECK "S" TERMINAL CONNECTION

1. Turn ignition switch OFF.
2. Check if "S" terminal is clean and tight.

#### Is the inspection result normal?

YES >> GO TO 2.

NO >> Repair "S" terminal connection. Confirm repair by performing complete Charging system test using EXP-800 NI or GR8-1200 NI (if available). Refer to applicable Instruction Manual for proper testing procedures.

### 2. CHECK VOLTAGE REGULATOR CIRCUIT

Check voltage between generator harness connector F7 terminal 3 and ground.

(+)		(-)	Voltage (approx.)
Connector	Terminal		
F7	3	Ground	Battery voltage

#### Does battery voltage exist?

YES >> Refer to [CHG-2, "Work Flow \(With EXP-800 NI or GR8-1200 NI\)"](#) or [CHG-5, "Work Flow \(Without EXP-800 NI or GR8-1200 NI\)"](#).

NO >> Check harness for open between generator and fuse.

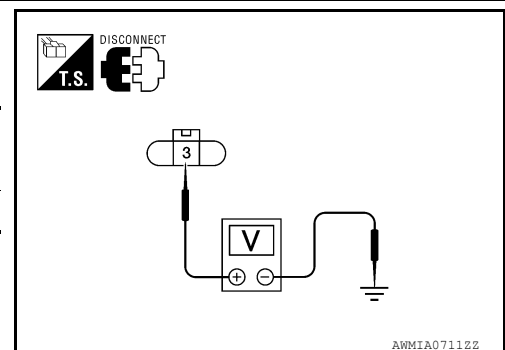



# CHARGING SYSTEM

< WIRING DIAGRAM >

## WIRING DIAGRAM

### CHARGING SYSTEM

Wiring Diagram

INFOID:000000007422143

CHARGING SYSTEM

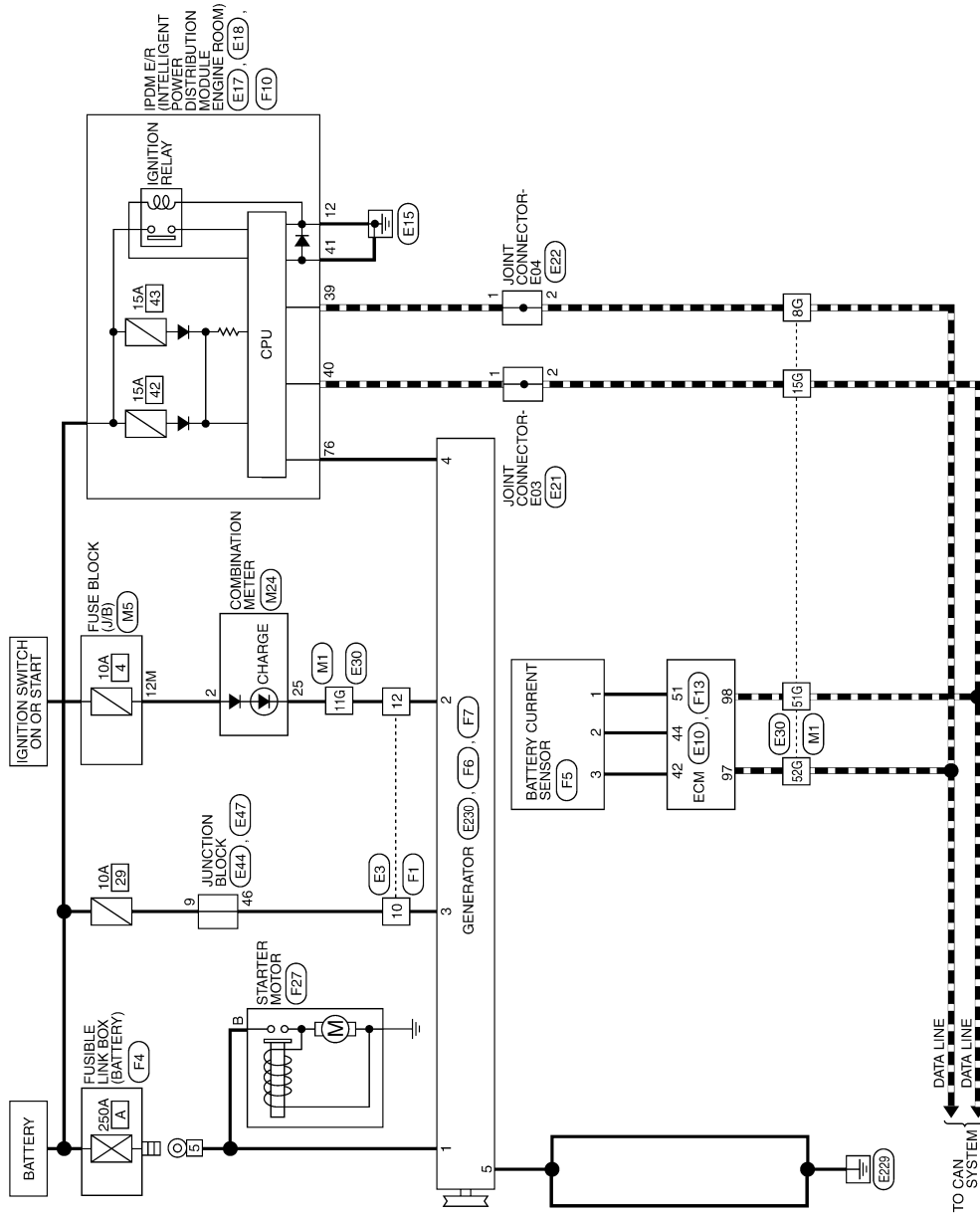

A  
B  
C  
D  
E  
F  
G  
H  
I  
J  
K  
L  
N  
O  
P

CHG

# CHARGING SYSTEM

< WIRING DIAGRAM >

## CHARGING SYSTEM CONNECTORS

Connector No.	M1
Connector Name	WIRE TO WIRE
Connector Color	WHITE

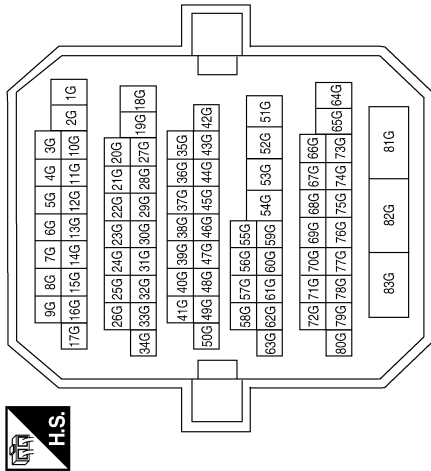

Terminal No.	Color of Wire	Signal Name
8G	P	-
11G	BR	-
15G	L	-
51G	L	-
52G	P	-

Connector No.	M5
Connector Name	FUSE BLOCK (J/B)
Connector Color	WHITE

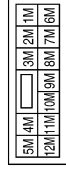

Terminal No.	Color of Wire	Signal Name
12M	O	-

Connector No.	M24
Connector Name	COMBINATION METER
Connector Color	WHITE

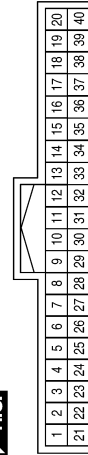

Terminal No.	Color of Wire	Signal Name
2	O	IGN
25	BR	CHG

Connector No.	E3
Connector Name	WIRE TO WIRE
Connector Color	WHITE

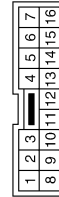

Terminal No.	Color of Wire	Signal Name
10	W	-
12	LG	-

Connector No.	E10
Connector Name	ECM
Connector Color	BLACK

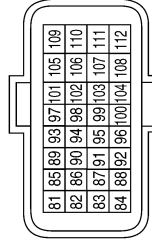

Terminal No.	Color of Wire	Signal Name
97	P	CAN-L
98	L	CAN-H

# CHARGING SYSTEM

< WIRING DIAGRAM >

Connector No.	E21
Connector Name	JOINT CONNECTOR-E03
Connector Color	WHITE



Terminal No.	Color of Wire	Signal Name
1	L	-
2	L	-

Connector No.	E18
Connector Name	IPDM E/R (INTELLIGENT POWER DISTRIBUTION MODULE ENGINE ROOM)
Connector Color	WHITE



Terminal No.	Color of Wire	Signal Name
12	B	GND (POWER)

Connector No.	E17
Connector Name	IPDM E/R (INTELLIGENT POWER DISTRIBUTION MODULE ENGINE ROOM)
Connector Color	WHITE

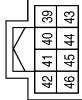

Terminal No.	Color of Wire	Signal Name
39	P	CAN-L
40	L	CAN-H
41	B	GND (SIGNAL)

Terminal No.	Color of Wire	Signal Name
8G	P	-
11G	LG	-
15G	L	-
51G	L	-
52G	P	-

Connector No.	E30
Connector Name	WIRE TO WIRE
Connector Color	WHITE

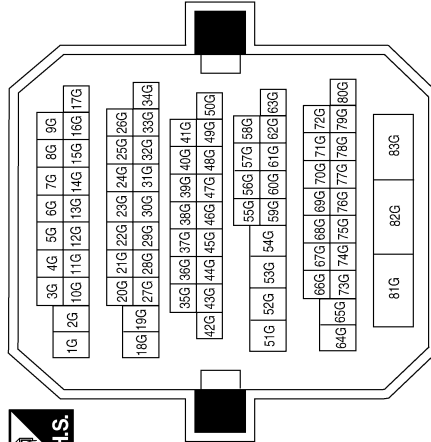

Connector No.	E22
Connector Name	JOINT CONNECTOR-E04
Connector Color	WHITE

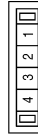

Terminal No.	Color of Wire	Signal Name
1	P	-
2	P	-

ABM1A1886GB

A  
B  
C  
D  
E  
F  
G  
H  
I  
J  
K  
L  
N  
O  
P

CHG

# CHARGING SYSTEM

< WIRING DIAGRAM >

Connector No.	E230
Connector Name	GENERATOR
Connector Color	-



Terminal No.	Color of Wire	Signal Name
5	B	GND

Connector No.	E47
Connector Name	JUNCTION BLOCK
Connector Color	WHITE

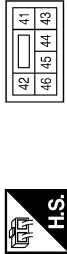

Terminal No.	Color of Wire	Signal Name
46	W	-

Connector No.	E44
Connector Name	JUNCTION BLOCK
Connector Color	BROWN

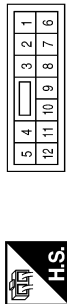

Terminal No.	Color of Wire	Signal Name
9	BR	-

Connector No.	F5
Connector Name	BATTERY CURRENT SENSOR
Connector Color	BLACK



Terminal No.	Color of Wire	Signal Name
1	BR	AVCC1 (WITH QR25DE)
1	P	AVCC1 (WITH VQ35DE)
2	B	GND (WITH QR25DE)
2	O	GND (WITH VQ35DE)
3	Y	SIGNAL (WITH QR25DE)
3	G	SIGNAL (WITH VQ35DE)

Connector No.	F4
Connector Name	FUSIBLE LINK BOX (BATTERY)
Connector Color	-



Terminal No.	Color of Wire	Signal Name
5	B/R	BATT

Connector No.	F1
Connector Name	WIRE TO WIRE
Connector Color	WHITE

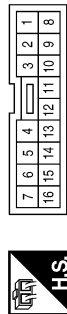

Terminal No.	Color of Wire	Signal Name
10	G	-(WITH QR25DE)
10	O	-(WITH VQ35DE)
12	BR	-

AAMIA0607GB

# CHARGING SYSTEM

< WIRING DIAGRAM >

Connector No.	F6
Connector Name	GENERATOR
Connector Color	-



Terminal No.	Color of Wire	Signal Name
1	B/R	BATT

Connector No.	F7
Connector Name	GENERATOR
Connector Color	BLACK



Terminal No.	Color of Wire	Signal Name
2	BR	CHG
3	G	BATT (WITH QR25DE)
3	O	BATT (WITH VQ35DE)
4	Y	-

Connector No.	F10
Connector Name	IPDM E/R (INTELLIGENT POWER DISTRIBUTION MODULE ENGINE ROOM)
Connector Color	WHITE

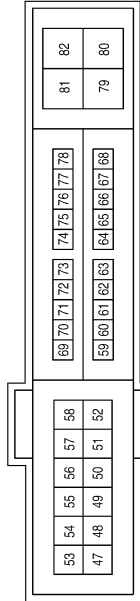

Terminal No.	Color of Wire	Signal Name
76	Y	ALT-C

Connector No.	F13
Connector Name	ECM
Connector Color	BROWN

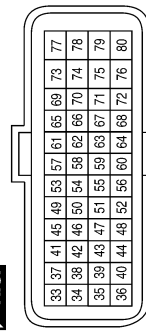

Terminal No.	Color of Wire	Signal Name
42	Y	CURSEN (WITH QR25DE)
42	G	CURSEN (WITH VQ35DE)
44	B	GND-CURSEN (WITH QR25DE)
44	O	GND-CURSEN, INTPRES1 (WITH VQ35DE)
51	BR	AVCC1-CURSEN (QR25DE)
51	P	AVCC1-CURSEN, INTPRES1 (WITH VQ35DE)

Connector No.	F27
Connector Name	STARTER MOTOR
Connector Color	-



Terminal No.	Color of Wire	Signal Name
B	B/R	BATT

A  
B  
C  
D  
E  
F  
G  
H  
I  
J  
K  
L  
M  
N  
O  
P

CHG

# CHARGING SYSTEM

< SYMPTOM DIAGNOSIS >

## SYMPTOM DIAGNOSIS

### CHARGING SYSTEM

#### Symptom Table

INFOID:000000007422144

Symptom	Reference
Battery discharged	Refer to <a href="#">CHG-2, "Work Flow (With EXP-800 NI or GR8-1200 NI)"</a> or <a href="#">CHG-5, "Work Flow (Without EXP-800 NI or GR8-1200 NI)"</a> .
The charge warning lamp does not illuminate when the ignition switch is set to ON.	
The charge warning lamp does not turn OFF after the engine starts.	
The charging warning lamp turns ON when increasing the engine speed.	

# PRECAUTIONS

< PRECAUTION >

## PRECAUTION

### PRECAUTIONS

#### Precaution for Supplemental Restraint System (SRS) "AIR BAG" and "SEAT BELT PRE-TENSIONER"

INFOID:000000007422145

The Supplemental Restraint System such as "AIR BAG" and "SEAT BELT PRE-TENSIONER", used along with a front seat belt, helps to reduce the risk or severity of injury to the driver and front passenger for certain types of collision. This system includes seat belt switch inputs and dual stage front air bag modules. The SRS system uses the seat belt switches to determine the front air bag deployment, and may only deploy one front air bag, depending on the severity of a collision and whether the front occupants are belted or unbelted. Information necessary to service the system safely is included in the SR and SB section of this Service Manual.

#### **WARNING:**

- To avoid rendering the SRS inoperative, which could increase the risk of personal injury or death in the event of a collision which would result in air bag inflation, all maintenance must be performed by an authorized NISSAN/INFINITI dealer.
- Improper maintenance, including incorrect removal and installation of the SRS, can lead to personal injury caused by unintentional activation of the system. For removal of Spiral Cable and Air Bag Module, see the SR section.
- Do not use electrical test equipment on any circuit related to the SRS unless instructed to in this Service Manual. SRS wiring harnesses can be identified by yellow and/or orange harnesses or harness connectors.

#### PRECAUTIONS WHEN USING POWER TOOLS (AIR OR ELECTRIC) AND HAMMERS

#### **WARNING:**

- When working near the Airbag Diagnosis Sensor Unit or other Airbag System sensors with the Ignition ON or engine running, DO NOT use air or electric power tools or strike near the sensor(s) with a hammer. Heavy vibration could activate the sensor(s) and deploy the air bag(s), possibly causing serious injury.
- When using air or electric power tools or hammers, always switch the Ignition OFF, disconnect the battery, and wait at least 3 minutes before performing any service.

#### Precaution Necessary for Steering Wheel Rotation After Battery Disconnect

INFOID:000000007422146

#### **NOTE:**

- Before removing and installing any control units, first turn the push-button ignition switch to the LOCK position, then disconnect both battery cables.
- After finishing work, confirm that all control unit connectors are connected properly, then re-connect both battery cables.
- Always use CONSULT to perform self-diagnosis as a part of each function inspection after finishing work. If a DTC is detected, perform trouble diagnosis according to self-diagnosis results.

This vehicle is equipped with a push-button ignition switch and a steering lock unit.

If the battery is disconnected or discharged, the steering wheel will lock and cannot be turned.

If turning the steering wheel is required with the battery disconnected or discharged, follow the procedure below before starting the repair operation.

#### OPERATION PROCEDURE

1. Connect both battery cables.

#### **NOTE:**

Supply power using jumper cables if battery is discharged.

2. Carry the Intelligent Key or insert it to the key slot and turn the push-button ignition switch to ACC position. (At this time, the steering lock will be released.)
3. Disconnect both battery cables. The steering lock will remain released with both battery cables disconnected and the steering wheel can be turned.
4. Perform the necessary repair operation.

A  
B  
C  
D  
E  
F  
G  
H  
I  
J  
K  
L  
CHG  
N  
O  
P

## PRECAUTIONS

### < PRECAUTION >

---

5. When the repair work is completed, re-connect both battery cables. With the brake pedal released, turn the push-button ignition switch from ACC position to ON position, then to LOCK position. (The steering wheel will lock when the push-button ignition switch is turned to LOCK position.)
6. Perform self-diagnosis check of all control units using CONSULT.

### Precaution for Power Generation Voltage Variable Control System

INFOID:000000007422147

#### **CAUTION:**

**For this model, the battery current sensor that is installed to the battery cable at the negative terminal measures the charging/discharging current of the battery, and performs various controls. If the electrical component or the ground wire is connected directly to the battery terminal, the current other than that being measured with the battery current sensor is charging to or discharging from the battery. This condition causes the malfunction of the control, and then the battery discharge may occur. Do not connect the electrical component or the ground wire directly to the battery terminal.**



# PREPARATION

< PREPARATION >

## PREPARATION

### PREPARATION

#### Special Service Tool

INFOID:000000007422148

The actual shapes of Kent-Moore tools may differ from those of special service tools illustrated here.

Tool number (Kent Moore No.) Tool name	Description
— (—) Model GR8-1200 NI Multitasking battery and electrical diagnostic station	Tests batteries, starting and charging systems and charges batteries. For operating instructions, refer to diagnostic station instruction manual.
— (—) Model EXP-800 NI Battery and electrical diagnostic analyzer	Tests batteries and charging systems. For operating instructions, refer to diagnostic analyzer instruction manual.

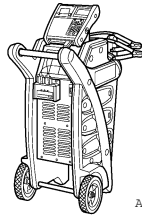

AWIIA1239Z2

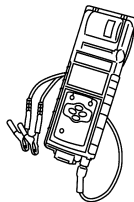

JSMIA0806Z2

#### Commercial Service Tool

INFOID:000000007422149

Tool name	Description
Power tool	Loosening nuts, screws and bolts



PIIB1407E

A  
B  
C  
D  
E  
F  
G  
H  
I  
J  
K  
L

**CHG**

# GENERATOR

< REMOVAL AND INSTALLATION >

## REMOVAL AND INSTALLATION

### GENERATOR

#### Removal and Installation

INFOID:000000007422150

QR25DE

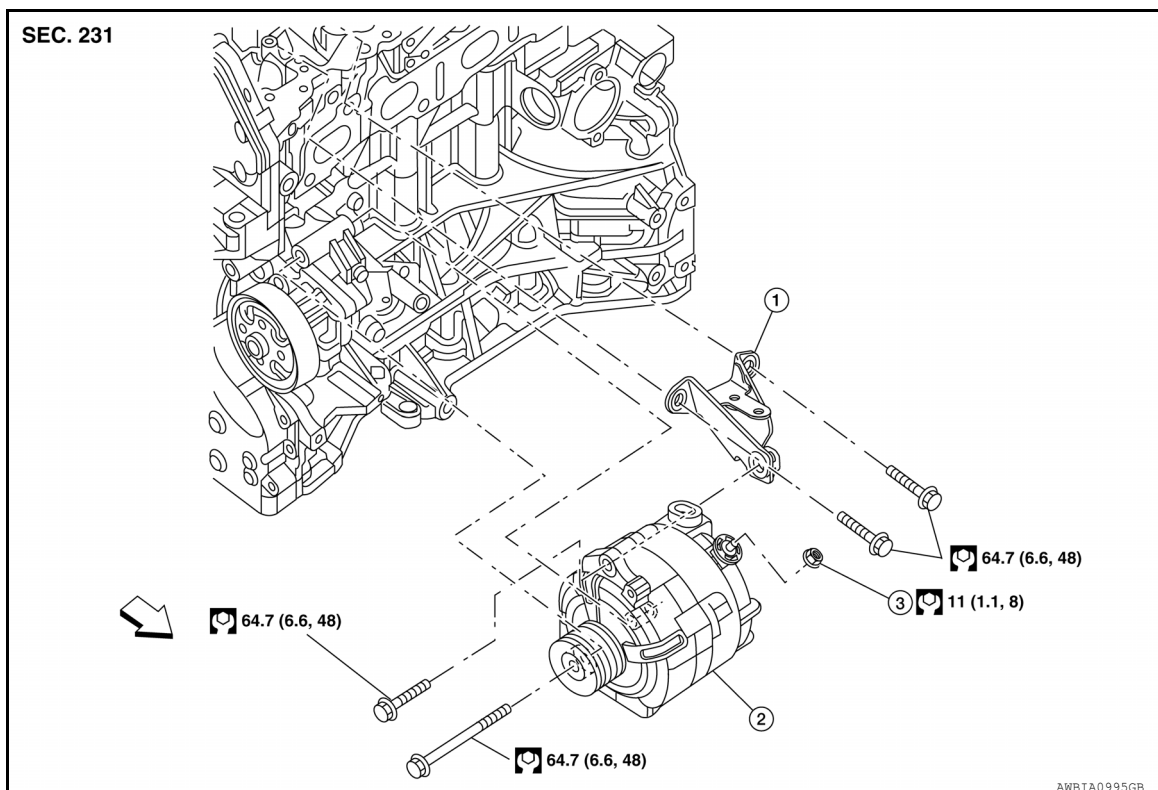

1. Generator bracket

2. Generator

3. B terminal nut

↶ Front

#### Removal

1. Disconnect the battery negative terminal. Refer to [PG-68, "Removal and Installation \(Battery\)"](#) (Coupe models) or [PG-140, "Removal and Installation \(Battery\)"](#) (Sedan models).
2. Remove fender protector side cover (RH). Refer to [EXT-22, "Removal and Installation"](#) (Coupe models) or [EXT-46, "Removal and Installation"](#) (Sedan models).
3. Remove drive belt. Refer to [EM-16, "Removal and Installation"](#).
4. Remove engine room cover.
5. Remove "B" terminal nut.
6. Disconnect the generator harness connectors.
7. Remove the generator bolts, using power tools.
8. Remove the generator assembly upward.

#### Installation

Installation is in the reverse order of removal.

#### CAUTION:

**Be sure to tighten "B" terminal nut carefully.**

- Check tension of drive belt. Refer to [EM-16, "Checking Drive Belts"](#).
- This model is equipped with a power generation voltage variable control system. Therefore perform an inspection of the power generation voltage variable control system operation after replacing the generator. Refer to [CHG-9, "System Description"](#).

# GENERATOR

< REMOVAL AND INSTALLATION >

VQ35DE

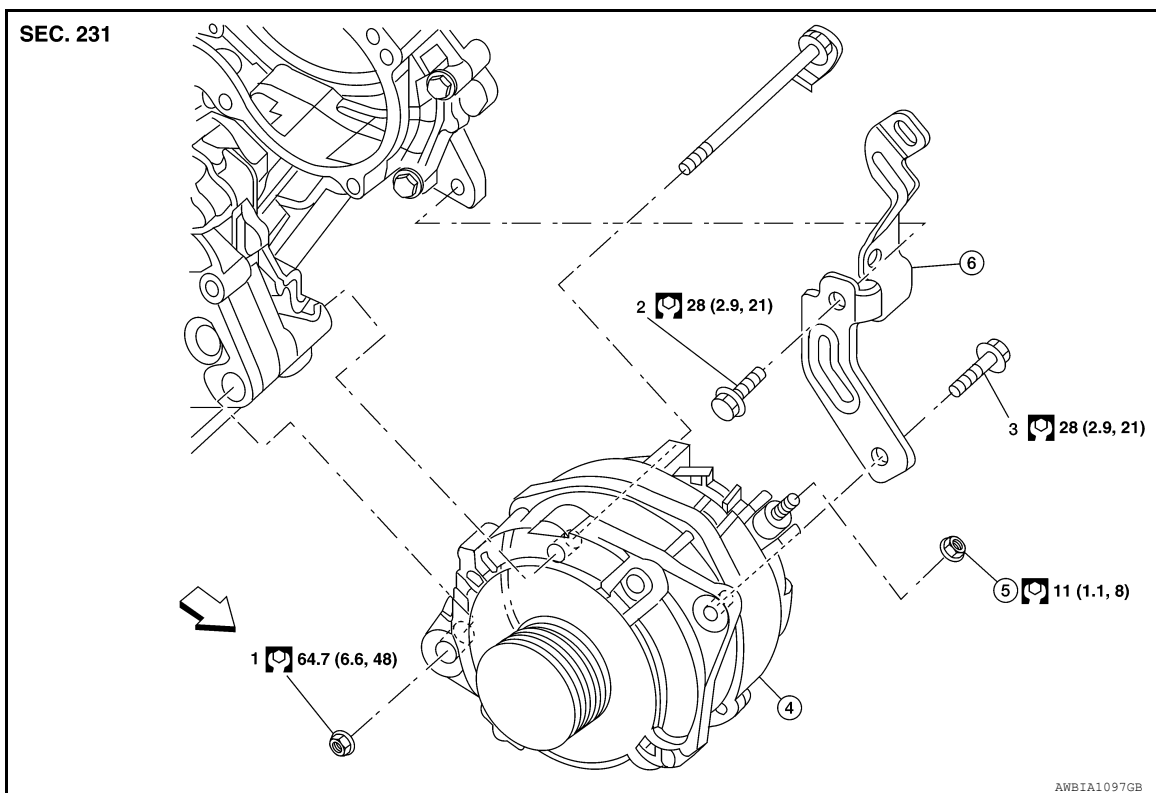

- 1.-3. Tightening order  
6. Generator bracket

4. Generator  
← Front

5. B terminal nut

## Removal

1. Disconnect the battery negative terminal. Refer to [PG-68, "Removal and Installation \(Battery\)"](#) (Coupe models) or [PG-140, "Removal and Installation \(Battery\)"](#) (Sedan models).
2. Remove engine undercover. Refer to [EXT-16, "Removal and Installation - Coupe"](#) (Coupe models) or [EXT-40, "Removal and Installation"](#) (Sedan models).
3. Partially drain engine coolant. Refer to [CO-36, "Changing Engine Coolant"](#).
4. Remove engine room cover.
5. Remove RH front wheel and tire assembly. Refer to [WT-68, "Adjustment"](#).
6. Remove fender protector side cover (RH). Refer to [EXT-22, "Removal and Installation"](#) (Coupe models) or [EXT-46, "Removal and Installation"](#) (Sedan models).
7. Remove air cleaner and duct assembly. Refer to [EM-132, "Removal and Installation"](#).
8. Remove battery tray and bracket. Refer to [PG-69, "Removal and Installation \(Battery Tray\)"](#) (Coupe models) or [PG-141, "Removal and Installation \(Battery Tray\)"](#) (Sedan models).
9. Remove cooling fan assembly and shroud. Refer to [CO-41, "Removal and Installation"](#).
10. Remove drive belt. Refer to [EM-123, "Removal and Installation"](#).
11. Release the clip and reposition power steering tube.
12. Remove the A/C compressor. Refer to [HA-32, "Removal and Installation for Compressor - VQ35DE Models"](#).
13. Remove the A/C idler pulley.
14. Disconnect the oil pressure switch.
15. Disconnect the generator harness connectors.
16. Remove the generator bracket, using power tools.
17. Remove the generator bolt and nuts, using power tools.
18. Slide the generator out and remove.

# GENERATOR

## < REMOVAL AND INSTALLATION >

---

### Installation

Installation is in the reverse order of removal.

### **CAUTION:**

**Be sure to tighten "B" terminal nut carefully.**

- Check tension of drive belt. Refer to [EM-123, "Checking Drive Belts"](#).
- This model is equipped with a power generation voltage variable control system. Therefore perform an inspection of the power generation voltage variable control system operation after replacing the generator. Refer to [CHG-9, "System Description"](#).

## SERVICE DATA AND SPECIFICATIONS (SDS)

< SERVICE DATA AND SPECIFICATIONS (SDS)

# SERVICE DATA AND SPECIFICATIONS (SDS)

## SERVICE DATA AND SPECIFICATIONS (SDS)

### Generator

INFOID:000000007422151

Engine application	QR25DE	VQ35DE
Manufacturer	Valeo	Mitsubishi
Model*	2611894	A003TJ3691ZC
Nominal rating	14V - 110A	13.5V - 130A
Ground polarity	Negative	
Minimum revolution under no-load	1,200 rpm	1,000 rpm
Hot output current (When 13.5 volts is applied)	More than 46A @ 1,500 rpm More than 68A @ 1,800 rpm More than 91A @ 2,500 rpm More than 105A @ 5,000 rpm	More than 66A @ 1,500 rpm More than 108A @ 2,500 rpm More than 124A @ 5,000 rpm
Regulated output voltage @ 20° C (68° F)	13.5V @ 5,000 rpm	14.4 ± 0.3V
Adjustment range of power generation variable voltage control	11.4 - 15.6V	11.4 - 15.6V

\*: Always check with the Parts Department for the latest parts information.

A  
B  
C  
D  
E  
F  
G  
H  
I  
J  
K  
L  
N  
O  
P

**CHG**