

SECTION **DEF**
DEFOGGER

A
B
C

CONTENTS

BASIC INSPECTION	3	ECU DIAGNOSIS INFORMATION	19	F
DIAGNOSIS AND REPAIR WORKFLOW	3	BCM (BODY CONTROL MODULE)	19	G
Work Flow	3	Reference Value	19	
SYSTEM DESCRIPTION	6	Terminal Layout	23	
REAR WINDOW DEFOGGER SYSTEM	6	Physical Values	23	H
System Diagram	6	WIRING DIAGRAM	42	
System Description	6	REAR WINDOW DEFOGGER	42	I
Component Parts Location	7	Wiring Diagram	42	
Component Description	7	SYMPTOM DIAGNOSIS	46	J
DIAGNOSIS SYSTEM (BCM)	8	REAR WINDOW DEFOGGER DOES NOT OPERATE	46	
COMMON ITEM	8	Diagnosis Procedure	46	K
COMMON ITEM : Diagnosis Description	8	REAR WINDOW DEFOGGER SWITCH DOES NOT LIGHT, BUT REAR WINDOW DEFOGGER OPERATES	47	
COMMON ITEM : CONSULT Function (BCM - COMMON ITEM)	8	Diagnosis Procedure	47	DEF
REAR WINDOW DEFOGGER	9	PRECAUTION	48	M
REAR WINDOW DEFOGGER : CONSULT Function (BCM - REAR DEFOGGER)	9	PRECAUTIONS	48	
DTC/CIRCUIT DIAGNOSIS	10	Precaution for Supplemental Restraint System (SRS) "AIR BAG" and "SEAT BELT PRE-TENSIONER"	48	N
REAR WINDOW DEFOGGER SWITCH	10	Precaution Necessary for Steering Wheel Rotation After Battery Disconnect	48	
Description	10	Precaution for Work	49	O
Component Function Check	10	PREPARATION	50	P
Diagnosis Procedure	10	PREPARATION	50	
REAR WINDOW DEFOGGER RELAY	14	Special Service Tool	50	
Description	14	Commercial Service Tool	50	
Component Function Check	14	REMOVAL AND INSTALLATION	51	
Diagnosis Procedure	14	FILAMENT	51	
Component Inspection	15	Inspection and Repair	51	
REAR WINDOW DEFOGGER POWER SUPPLY AND GROUND CIRCUIT	16			
Description	16			
Component Function Check	16			
Diagnosis Procedure	16			
Component Inspection	18			

CONDENSER	53	Removal and Installation - Sedan	53
Removal and Installation - Coupe	53		

DIAGNOSIS AND REPAIR WORKFLOW

< BASIC INSPECTION >

BASIC INSPECTION

DIAGNOSIS AND REPAIR WORKFLOW

Work Flow

INFOID:000000007422737

OVERALL SEQUENCE

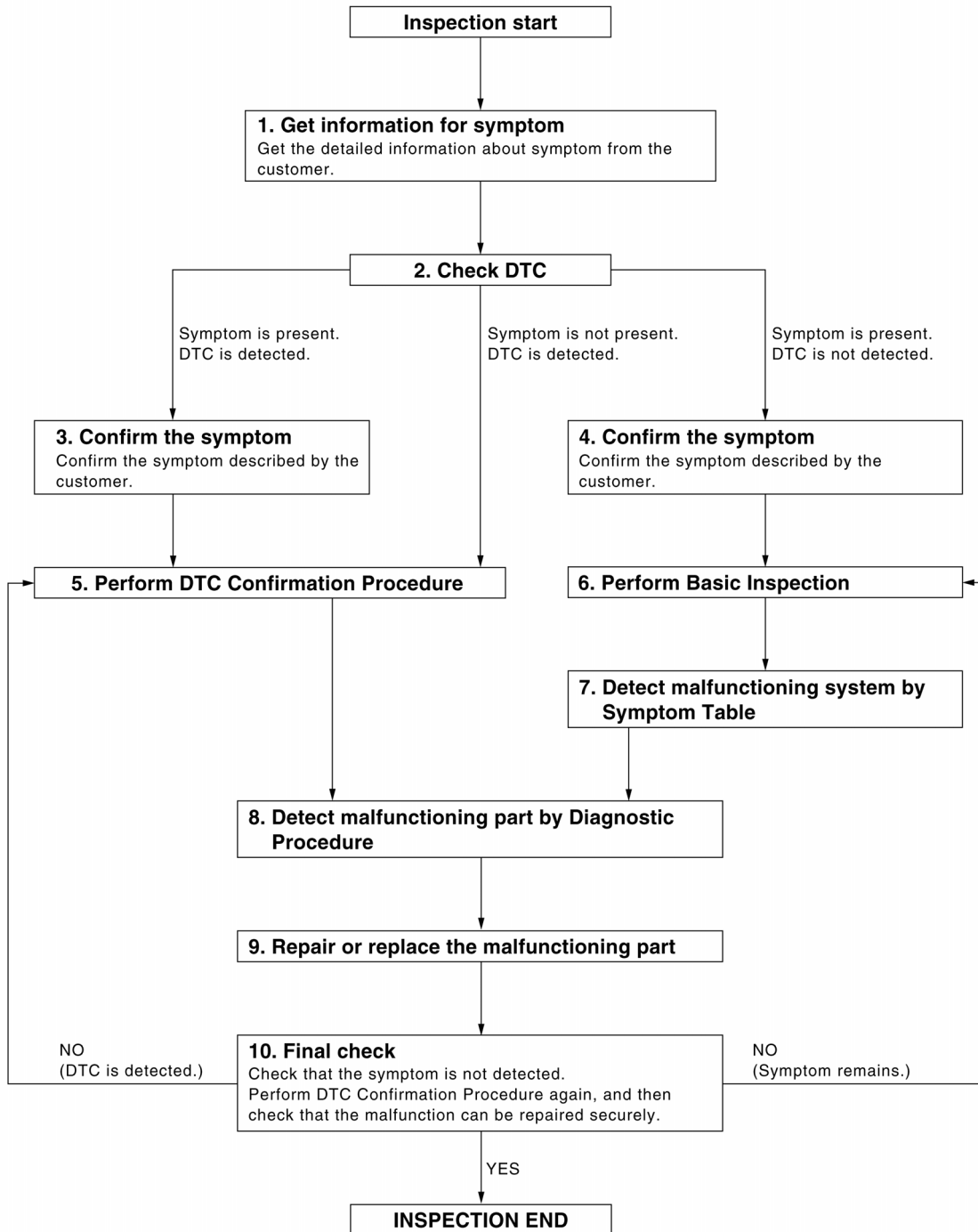

DETAILED FLOW

DIAGNOSIS AND REPAIR WORKFLOW

< BASIC INSPECTION >

1. GET INFORMATION FOR SYMPTOM

Get the detailed information from the customer about the symptom (the condition and the environment when the incident/malfunction occurred).

>> GO TO 2

2. CHECK DTC

1. Check DTC.
2. Perform the following procedure if DTC is displayed.
 - Record DTC and freeze frame data (Print them out with CONSULT.)
 - Erase DTC.
 - Study the relationship between the cause detected by DTC and the symptom described by the customer.
3. Check related service bulletins for information.

Is any symptom described and any DTC detected?

Symptom is described, DTC is displayed>>GO TO 3

Symptom is described, DTC is not displayed>>GO TO 4

Symptom is not described, DTC is displayed>>GO TO 5

3. CONFIRM THE SYMPTOM

Confirm the symptom described by the customer.

Connect CONSULT to the vehicle in "DATA MONITOR" mode and check real time diagnosis results.

Verify relation between the symptom and the condition when the symptom is detected.

>> GO TO 5

4. CONFIRM THE SYMPTOM

Confirm the symptom described by the customer.

Connect CONSULT to the vehicle in "DATA MONITOR" mode and check real time diagnosis results.

Verify relation between the symptom and the condition when the symptom is detected.

>> GO TO 6

5. PERFORM DTC CONFIRMATION PROCEDURE

Perform DTC Confirmation Procedure for the displayed DTC, and then check that DTC is detected again.

At this time, always connect CONSULT to the vehicle, and check diagnostic results in real time.

If two or more DTCs are detected, refer to [BCS-65. "DTC Inspection Priority Chart"](#) and determine trouble diagnosis order.

NOTE:

- Freeze frame data is useful if the DTC is not detected.
- Perform Component Function Check if DTC Confirmation Procedure is not included in Service Manual. This simplified check procedure is an effective alternative though DTC cannot be detected during this check. If the result of Component Function Check is NG, it is the same as the detection of DTC by DTC Confirmation Procedure.

Is DTC detected?

YES >> GO TO 8

NO >> Refer to [GI-42. "Intermittent Incident"](#).

6. PERFORM BASIC INSPECTION

Perform [DEF-3. "Work Flow"](#).

Inspection End>>GO TO 7

7. DETECT MALFUNCTIONING SYSTEM BY SYMPTOM TABLE

Detect malfunctioning system according to [DEF-6. "System Description"](#) based on the confirmed symptom in step 4, and determine the trouble diagnosis order based on possible causes and symptom.

>> GO TO 8

DIAGNOSIS AND REPAIR WORKFLOW

< BASIC INSPECTION >

8. DETECT MALFUNCTIONING PART BY DIAGNOSTIC PROCEDURE

Inspect according to Diagnostic Procedure of the system.

NOTE:

The Diagnostic Procedure described based on open circuit inspection. A short circuit inspection is also required for the circuit check in the Diagnostic Procedure.

Is malfunctioning part detected?

YES >> GO TO 9

NO >> Check voltage of related BCM terminals using CONSULT.

9. REPAIR OR REPLACE THE MALFUNCTIONING PART

1. Repair or replace the malfunctioning part.
2. Reconnect parts or connectors disconnected during Diagnostic Procedure again after repair and replacement.
3. Check DTC. If DTC is displayed, erase it.

>> GO TO 10

10. FINAL CHECK

When DTC was detected in step 2, perform DTC Confirmation Procedure or Component Function Check again, and then check that the malfunction have been repaired securely.

When symptom was described from the customer, refer to confirmed symptom in step 3 or 4, and check that the symptom is not detected.

Does the symptom reappear?

YES (DTC is detected)>>GO TO 5

YES (Symptom remains)>>GO TO 6

NO >> Inspection End.

A
B
C
D
E
F
G
H
I
J
K
DEF
M
N
O
P

REAR WINDOW DEFOGGER SYSTEM

< SYSTEM DESCRIPTION >

SYSTEM DESCRIPTION

REAR WINDOW DEFOGGER SYSTEM

System Diagram

INFOID:000000007422738

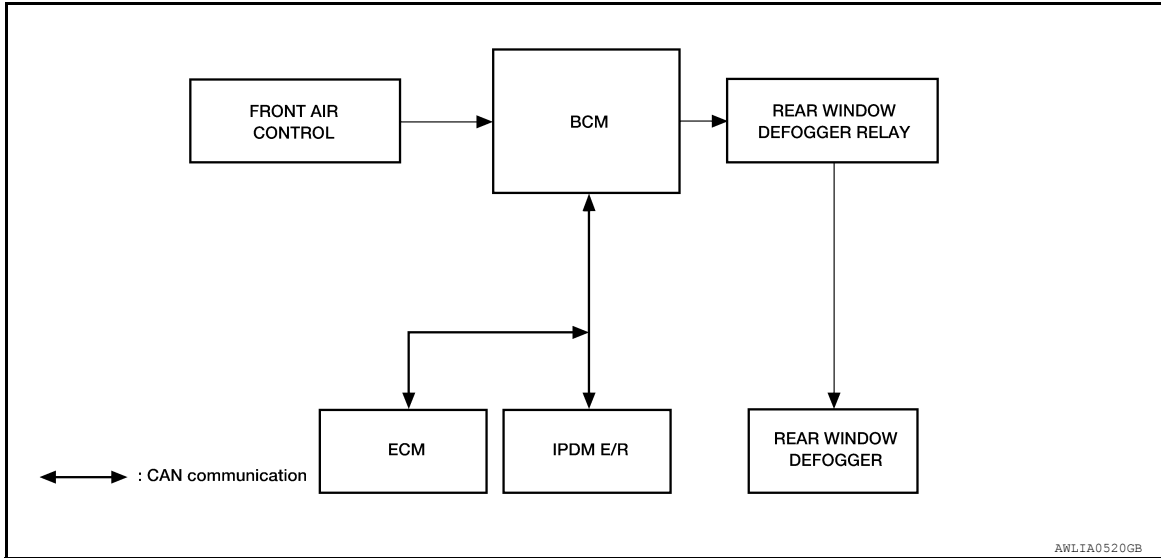

System Description

INFOID:000000007422739

Operation Description

- When rear window defogger switch is turned ON while ignition switch is ON, the front air control (rear window defogger switch) transmits rear window defogger switch signal to BCM.
- BCM turns rear window defogger relay ON when rear window defogger switch signal is received.
- Rear window defogger is supplied with power and operates when rear window defogger relay turns ON.
- BCM transmits rear window defogger control signal to IPDM E/R via CAN communication when rear window defogger operates.
- Rear window defogger ON is displayed when front air control receives signals.

Timer function

- BCM turns rear window defogger relay ON for approximately 15 minutes when rear window defogger switch is turned ON while ignition switch is ON. It makes rear window defogger operate.
- Timer is canceled after pressing rear window defogger switch again during timer operation. Then BCM turns rear window defogger relay OFF. The same reaction also occurs during timer operation, if the ignition switch is turned OFF.

INPUT/OUTPUT SIGNAL CHART

Switch	Input signal to BCM	BCM function	Actuator
Rear window defogger switch	Defogger switch signal	Rear window defogger control	Rear window defogger
Push button ignition switch	Ignition signal		

REAR WINDOW DEFOGGER SYSTEM

< SYSTEM DESCRIPTION >

Component Parts Location

INFOID:000000007422740

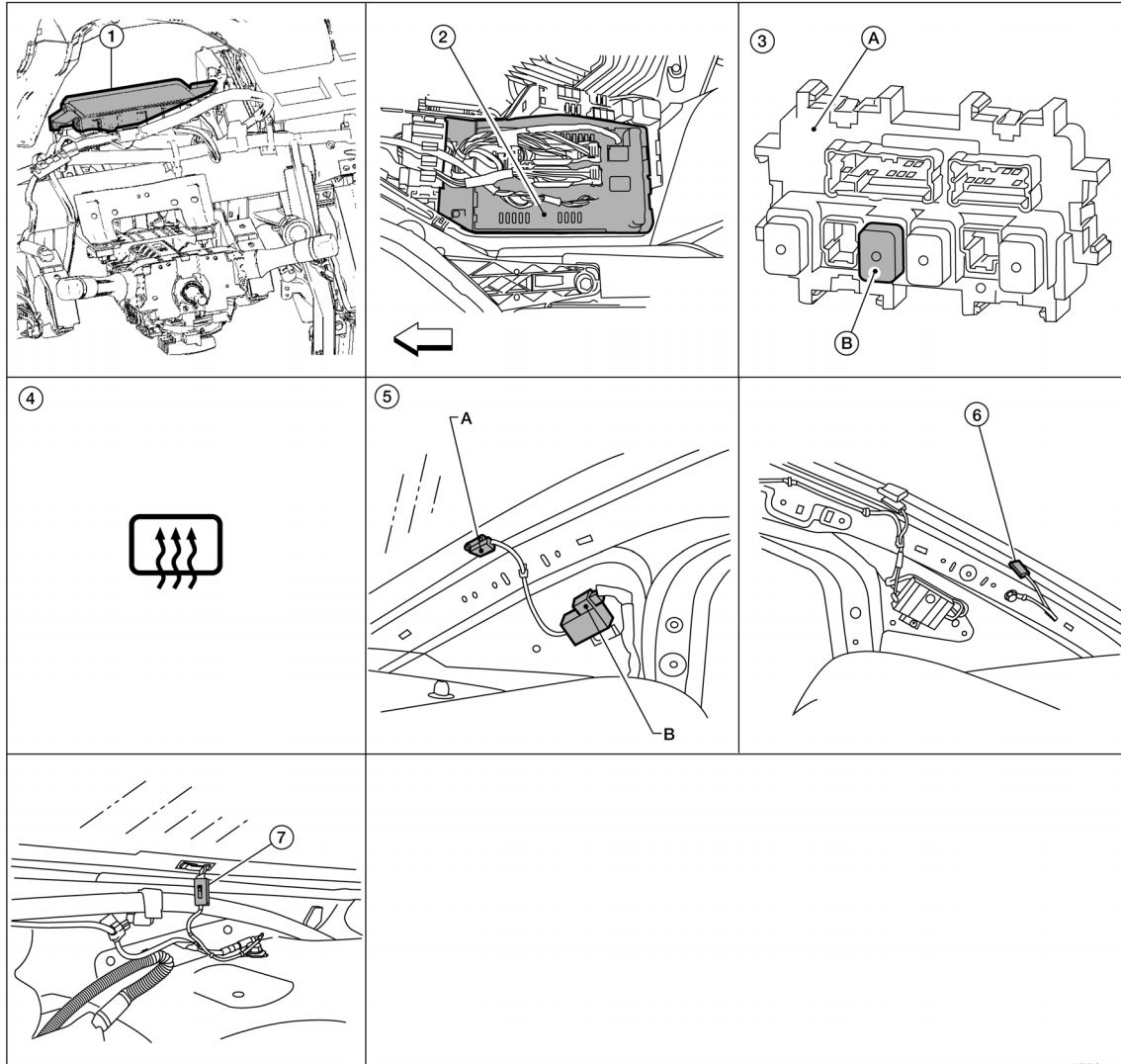

A
B
C
D
E
F
G
H
I
J
K

- | | | |
|---|--|--|
| <p>1. BCM M16, M17, M18, M19 (view with instrument panel removed)</p> <p>4. Front air control (rear window defogger switch) M37</p> <p>7. Rear window defogger M54 (coupe models with sunroof) (view with parcel shelf removed)</p> | <p>2. IPDM E/R E17</p> <p>5. A. Rear window defogger B53
B. Condenser B52 (view with rear pillar finisher removed)</p> | <p>3. A. Fuse block (J/B)
B. Rear window defogger relay J-2</p> <p>6. Rear window defogger M54 (all models except coupe with sunroof) (view with rear pillar finisher removed)</p> |
|---|--|--|

ANL1A17792Z

DEF

Component Description

INFOID:000000007422741

BCM	<ul style="list-style-type: none"> Operates the rear window defogger with the operation of rear window defogger switch. Performs the timer control of rear window defogger.
Rear window defogger relay	<ul style="list-style-type: none"> Operates the rear window defogger with the control signal from BCM.
Front air control (rear window defogger switch)	<ul style="list-style-type: none"> The rear window defogger switch is installed. Turns the indicator lamp ON when detecting the operation of rear window defogger.
Rear window defogger	<ul style="list-style-type: none"> Heats the heating wire with the power supply from the rear window defogger relay to prevent the rear window from fogging up.

M
N
O
P

DIAGNOSIS SYSTEM (BCM)

< SYSTEM DESCRIPTION >

DIAGNOSIS SYSTEM (BCM)

COMMON ITEM

COMMON ITEM : Diagnosis Description

INFOID:000000007630952

BCM CONSULT FUNCTION

CONSULT performs the following functions via CAN communication with BCM.

Diagnosis mode	Function Description
WORK SUPPORT	Changes the setting for each system function.
SELF-DIAG RESULTS	Displays the diagnosis results judged by BCM.
CAN DIAG SUPPORT MNTR	Monitors the reception status of CAN communication viewed from BCM.
DATA MONITOR	The BCM input/output signals are displayed.
ACTIVE TEST	The signals used to activate each device are forcibly supplied from BCM.
ECU IDENTIFICATION	The BCM part number is displayed.
CONFIGURATION	This function is not used even though it is displayed.

SYSTEM APPLICATION

BCM can perform the following functions for each system.

NOTE:

It can perform the diagnosis modes except the following for all sub system selection items.

System	Sub system selection item	Diagnosis mode		
		WORK SUPPORT	DATA MONITOR	ACTIVE TEST
Door lock	DOOR LOCK	×	×	×
Rear window defogger	REAR DEFOGGER		×	×
Warning chime	BUZZER		×	×
Interior room lamp timer	INT LAMP		×	×
Remote keyless entry system	MULTI REMOTE ENT		×	
Exterior lamp	HEAD LAMP	×	×	×
Wiper and washer	WIPER	×	×	×
Turn signal and hazard warning lamps	FLASHER	×	×	×
Air conditioner	AIR CONDITONER		×	
Intelligent Key system	INTELLIGENT KEY	×	×	×
Combination switch	COMB SW		×	
BCM	BCM	×		
Immobilizer	IMMU		×	×
Interior room lamp battery saver	BATTERY SAVER	×	×	
Trunk open	TRUNK		×	×
Vehicle security system	THEFT ALM	×	×	×
RAP system	RETAINED PWR		×	
Signal buffer system	SIGNAL BUFFER		×	×
TPMS	AIR PRESSURE MONITOR	×	×	×

COMMON ITEM : CONSULT Function (BCM - COMMON ITEM)

INFOID:000000007422742

ECU IDENTIFICATION

Displays the BCM part No.

SELF-DIAG RESULT

Refer to [BCS-67. "DTC Index"](#).

DIAGNOSIS SYSTEM (BCM)

< SYSTEM DESCRIPTION >

REAR WINDOW DEFOGGER

REAR WINDOW DEFOGGER : CONSULT Function (BCM - REAR DEFOGGER)

INFOID:000000007630953

DATA MONITOR

Monitor Item [Unit]	Description
PUSH SW [ON/OFF]	Indicates condition of push switch
REAR DEF SW [ON/OFF]	Displays "Press (ON)/other (OFF)" status determined with the rear window defogger switch

ACTIVE TEST

Test Item	Description
REAR DEFOGGER	This test is able to check rear window defogger operation. Rear window defogger operates when "ON" on CONSULT screen is touched

A
B
C
D
E
F
G
H
I
J
K
DEF
M
N
O
P

DEF

REAR WINDOW DEFOGGER SWITCH

< DTC/CIRCUIT DIAGNOSIS >

DTC/CIRCUIT DIAGNOSIS

REAR WINDOW DEFOGGER SWITCH

Description

INFOID:000000007422744

- The rear window defogger is operated by pressing the rear window defogger switch ON.
- The indicator lamp in the rear window defogger switch illuminates while the rear window defogger is ON.

Component Function Check

INFOID:000000007422745

1. CHECK REAR WINDOW DEFOGGER SWITCH FUNCTION

1. Push ignition switch to ON.
2. Press rear window defogger switch.
3. Check that the indicator lamp of the rear window defogger switch illuminates.
4. Press rear window defogger switch.
5. Check that the indicator lamp of the rear window defogger switch extinguishes.

Is the inspection result normal?

- YES >> Rear window defogger switch function is OK.
NO >> Refer to [DEF-10, "Diagnosis Procedure"](#).

Diagnosis Procedure

INFOID:000000007422746

Regarding Wiring Diagram information, refer to [DEF-42, "Wiring Diagram"](#).

1. CHECK REAR WINDOW DEFOGGER RELAY OPERATION

1. Push the ignition switch to ON.
2. Check that an operation noise of rear window defogger relay [located in fuse block (J/B)] can be heard when pressing the rear window defogger switch ON and OFF.

Is the inspection result normal?

- YES >> GO TO 2
NO >> GO TO 5

2. CHECK FUSE

Check if Fuse 13 from the rear window defogger relay output is blown.

Is the fuse blown?

- YES >> Replace the blown fuse after repairing the affected circuit.
NO >> GO TO 3

3. CHECK FOR VOLTAGE FROM THE REAR WINDOW DEFOGGER RELAY

1. Connect a voltmeter between Fuse 13 and ground.
2. While pressing the rear window defogger switch ON and OFF, check for voltage between fuse block (J/B) connector M5 terminal 9M and ground.

Terminals		Condition of rear window defogger switch	Voltage (V) (Approx.)
(+)	(-)		
Fuse block (J/B) connector	Terminal		
M5	9M	ON	Battery voltage
		OFF	0

Is the inspection result normal?

- YES >> GO TO 4
NO >> Perform rear window defogger relay component inspection. Refer to [DEF-18, "Component Inspection"](#). If OK, repair fuse block as necessary.

REAR WINDOW DEFOGGER SWITCH

< DTC/CIRCUIT DIAGNOSIS >

4. CHECK REAR WINDOW DEFOGGER SWITCH INDICATOR CIRCUIT

1. Press rear window defogger switch.
2. Check for voltage between front air control connector and ground.

Terminals		(-)	Condition of rear window defogger switch	Voltage (V) (Approx.)
(+) Front air control connector				
Terminal		Ground	ON	Battery voltage
M37 (without auto A/C)	4			
M37 (with auto A/C)	22		OFF	0

Is the inspection result normal?

- YES >> Replace front air control. Refer to [VTL-9, "Removal and Installation"](#).
 NO >> Repair or replace harness.

5. CHECK FRONT AIR CONTROL (REAR WINDOW DEFOGGER SWITCH) FUNCTION

CONSULT

1. Select BCM (REAR DEFOGGER) DATA MONITOR.
2. While pressing and releasing the rear window defogger switch, check that the switch state changes between ON and OFF.

REAR DEF SW : ON

REAR DEF SW : OFF

Is the inspection result normal?

- YES >> GO TO 8
 NO >> GO TO 6

6. CHECK REAR WINDOW DEFOGGER ON SIGNAL CIRCUIT

Check voltage between BCM connector M18 terminal 38 and ground.

Terminals		(-)	Condition of rear window defogger switch	Voltage (V) (Approx.)
(+) BCM connector				
Terminal		Ground	ON	0
M18	38			

Is the inspection result normal?

- YES >> Replace BCM. Refer to [BCS-92, "Removal and Installation"](#).
 NO >> GO TO 7

7. CHECK HARNESS CONTINUITY

1. Push ignition switch to OFF.
2. Disconnect BCM and Front Air Control.
3. Check continuity between BCM connector and front air control connector.

BCM connector	Terminal	Front air control connector	Terminal	Continuity
M18 (without auto A/C)	38	M37 (without auto A/C)	12	Yes
M18 (with auto A/C)	38	M37 (with auto A/C)	23	Yes

4. Check continuity between BCM harness connector M18 terminal 38 and ground.

BCM connector	Terminal	Ground	Terminal	Continuity
M18	38	-	-	No

Is the inspection result normal?

- YES >> Replace front air control. Refer to [VTL-9, "Removal and Installation"](#).

A
B
C
D
E
F
G
H
I
J
K
M
N
O
P

DEF

REAR WINDOW DEFOGGER SWITCH

< DTC/CIRCUIT DIAGNOSIS >

NO >> Repair or replace harness.

8. CHECK REAR WINDOW DEFOGGER RELAY GROUND CIRCUIT

CONSULT

1. Select BCM (REAR DEFOGGER) ACTIVE TEST.
2. Turn REAR DEFOGGER active test ON and OFF.
3. Check voltage between fuse block (J/B) connector M4 terminal 4Q and ground.

REAR DEFOGGER : ON
REAR DEFOGGER : OFF

Terminals		(-)	Condition of rear window defogger Active Test	Voltage (V) (Approx.)
(+)				
Fuse Block	Terminal			
M4	4Q	Ground	ON	0
			OFF	Battery voltage

Is the inspection result normal?

- YES >> GO TO 11
 NO >> GO TO 9

9. CHECK REAR WINDOW DEFOGGER RELAY CIRCUIT

Check voltage between fuse block (J/B) connector M4 terminal 4Q and ground.

Terminals		(-)	Condition of Push switch	Voltage (V) (Approx.)
(+)				
Fuse block (J/B)	Terminal			
M4	4Q	Ground	ON	0
			OFF	Battery Voltage

Is the inspection result normal?

- YES >> Replace rear window defogger relay.
 NO >> GO TO 10

10. CHECK HARNESS CONTINUITY

1. Push ignition switch to OFF.
2. Disconnect BCM and fuse block (J/B).
3. Check continuity between BCM connector M18 terminal 59 and fuse block (J/B) connector M4 terminal 4Q.

BCM connector	Terminal	Fuse block (J/B) connector	Terminal	Continuity
M18	59	M4	4Q	Yes

4. Check continuity between fuse block (J/B) connector M4 terminal 4Q and ground.

fuse block (J/B) connector	Terminal	Ground	Continuity
M4	4Q	-	No

Is the inspection result normal?

- YES >> Perform rear window defogger relay component inspection. Refer to [DEF-18, "Component Inspection"](#). If OK, replace BCM. Refer to [BCS-92, "Removal and Installation"](#).
 NO >> Repair or replace harness.

11. CHECK REAR WINDOW DEFOGGER RELAY

Check rear window defogger relay.

REAR WINDOW DEFOGGER SWITCH

< DTC/CIRCUIT DIAGNOSIS >

Refer to [DEF-18, "Component Inspection"](#).

Is the inspection result normal?

YES >> GO TO 12

NO >> Replace rear window defogger relay.

12. CHECK INTERMITTENT INCIDENT

Check intermittent incident.

Refer to [GI-42, "Intermittent Incident"](#).

Is the inspection result normal?

YES >> Check the following.

- Battery power supply circuit.
- Fuse block (J/B).

NO >> Repair or replace the malfunctioning parts.

A

B

C

D

E

F

G

H

I

J

K

DEF

M

N

O

P

REAR WINDOW DEFOGGER RELAY

< DTC/CIRCUIT DIAGNOSIS >

REAR WINDOW DEFOGGER RELAY

Description

INFOID:000000007422747

Power is supplied to the rear window defogger with BCM control.

Component Function Check

INFOID:000000007422748

1. CHECK REAR WINDOW DEFOGGER RELAY POWER SUPPLY CIRCUIT

Check that an operation noise of rear window defogger relay [located in fuse block (J/B)] can be heard when turning the rear window defogger switch ON.

Is the inspection result normal?

- YES >> Rear window defogger relay power supply circuit is OK.
- NO >> Refer to [DEF-14, "Diagnosis Procedure"](#).

Diagnosis Procedure

INFOID:000000007422749

Regarding Wiring Diagram information, refer to [DEF-42, "Wiring Diagram"](#).

1. CHECK REAR WINDOW DEFOGGER RELAY GROUND CIRCUIT

1. Turn ignition switch ON.
2. Check voltage between BCM connector and ground.

Terminals		Condition of rear window defogger switch	Voltage (V) (Approx.)
(+)	(-)		
BCM connector	Terminal		
M18	59	ON	0
		OFF	Battery voltage

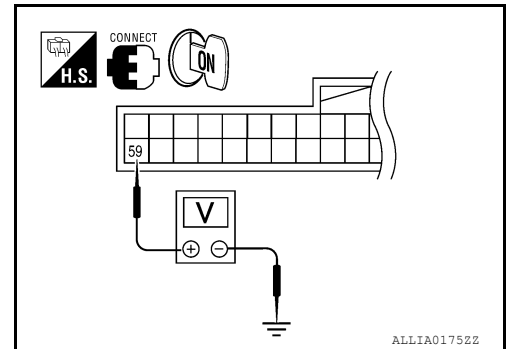

Is the inspection result normal?

- YES >> Rear window defogger power supply circuit is OK.
- NO >> GO TO 2

2. CHECK HARNESS CONTINUITY

1. Turn ignition switch OFF.
2. Disconnect BCM and rear window defogger relay.
3. Check continuity between BCM connector M18 (A) terminal 59 and rear window defogger relay connector M4 (B) terminal 4Q.

BCM connector	Terminal	Fuse block (J/B) connector	Terminal	Continuity
M18	59	M4	4Q	Yes

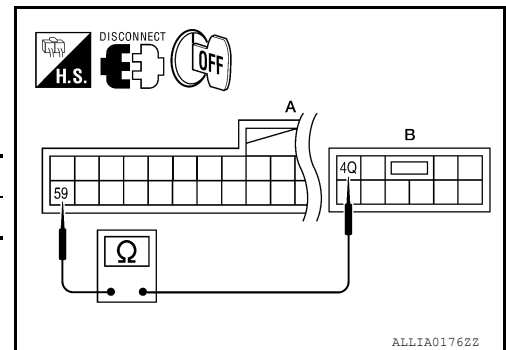

Is the inspection result normal?

- YES >> GO TO 3
- NO >> Repair or replace harness.

3. CHECK REAR WINDOW DEFOGGER RELAY

Check rear window defogger relay.
Refer to [DEF-15, "Component Inspection"](#).

Is the inspection result normal?

- YES >> GO TO 4
- NO >> Replace rear window defogger relay.

4. CHECK INTERMITTENT INCIDENT

Check intermittent incident.

REAR WINDOW DEFOGGER RELAY

< DTC/CIRCUIT DIAGNOSIS >

Refer to [GI-42. "Intermittent Incident"](#).

Is the inspection result normal?

- YES >> Check the following.
- Battery power supply circuit
 - Fuse block (J/B)
- NO >> Repair or replace the malfunctioning parts.

Component Inspection

INFOID:000000007422750

1. CHECK REAR WINDOW DEFOGGER RELAY

Check rear window defogger relay.

Terminal		Condition	Continuity
Rear window defogger relay			
3	5	12V direct current supply between terminals 1 and 2.	Yes
		No current supply	No

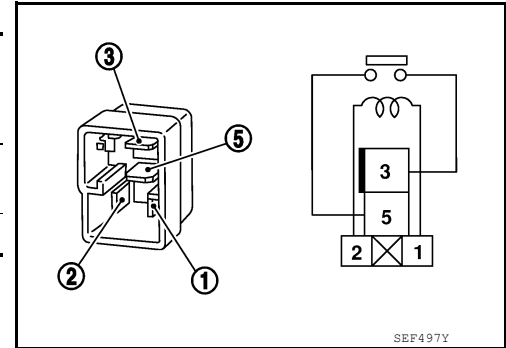

Is the inspection result normal?

- YES >> Inspection End.
- NO >> Replace rear window defogger relay.

A
B
C
D
E
F
G
H
I
J
K
L
M
N
O
P

DEF

REAR WINDOW DEFOGGER POWER SUPPLY AND GROUND CIRCUIT

< DTC/CIRCUIT DIAGNOSIS >

REAR WINDOW DEFOGGER POWER SUPPLY AND GROUND CIRCUIT

Description

INFOID:000000007422751

Heats the heating wire with the power supply from the rear window defogger relay to prevent the rear window from fogging up.

Component Function Check

INFOID:000000007422752

1. CHECK REAR WINDOW DEFOGGER

Check that the heating wire of rear window defogger is heated when turning the rear window defogger switch ON.

Is the inspection result normal?

- YES >> Rear window defogger is OK.
- NO >> Refer to [DEF-16, "Diagnosis Procedure"](#).

Diagnosis Procedure

INFOID:000000007422753

Regarding Wiring Diagram information, refer to [DEF-42, "Wiring Diagram"](#).

1. CHECK FUSES

Check if any of the following fuses in fuse block (J/B) are blown.

COMPONENT PARTS	RATING	FUSE NO.
Fuse block (J/B)	20A	14
	20A	15

Is the inspection result normal?

- YES >> GO TO 2
- NO >> Replace the blown fuse after repairing the affected circuit.

2. CHECK REAR WINDOW DEFOGGER POWER SUPPLY CIRCUIT

1. Turn ignition switch ON.
2. Check voltage between fuse block (J/B) connector and ground.

Terminals		Condition of rear window defogger switch	Voltage (V) (Approx.)
(+)	(-)		
Fuse block (J/B) connector	Terminal		
B4	10T, 11T	Ground	Battery voltage
			0

Is the inspection result normal?

- YES >> GO TO 3
- NO >> Replace fuse block (J/B).

3. CHECK POWER SUPPLY CIRCUIT

REAR WINDOW DEFOGGER POWER SUPPLY AND GROUND CIRCUIT

< DTC/CIRCUIT DIAGNOSIS >

1. Turn ignition switch ON.
2. Check voltage between rear window defogger connector and ground.

Terminals		(-)	Condition of rear window defogger switch	Voltage (V) (Approx.)
(+)				
Rear window defogger connector	Terminal			
B53	1	Ground	ON	Battery voltage
			OFF	0

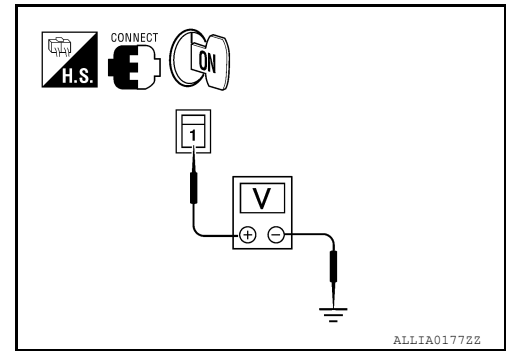

Is the inspection result normal?

YES >> GO TO 4

NO >> GO TO 5

4. CHECK GROUND CIRCUIT

1. Turn ignition switch OFF.
2. Disconnect rear window defogger.
3. Check continuity between rear window defogger connector and ground.

Rear window defogger connector	Terminal	Ground	Continuity
B54	2		Yes

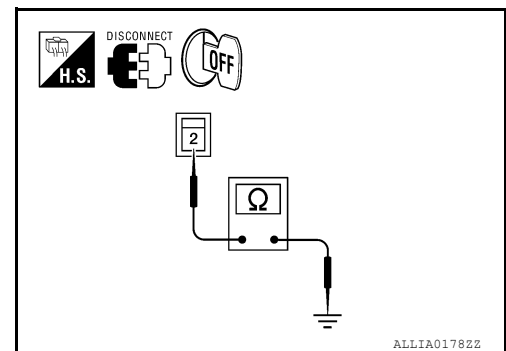

Is the inspection result normal?

YES >> GO TO 7

NO >> Repair or replace harness.

5. CHECK HARNESS CONTINUITY 1

1. Turn ignition switch OFF.
2. Disconnect condenser and rear window defogger.
3. Check continuity between condenser connector B52 (A) terminal 1 and rear window defogger connector B53 (B) terminal 1.

Condenser connector	Terminal	Rear window defogger connector	Terminal	Continuity
B52 (A)	1	B53 (B)	1	Yes

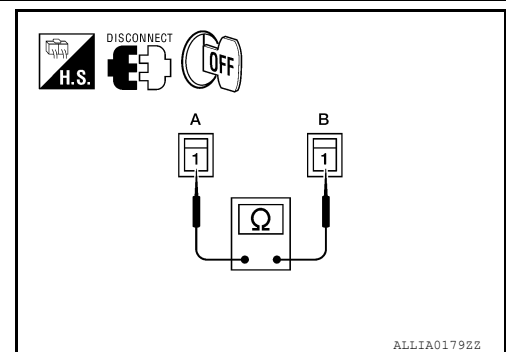

Is the inspection result normal?

YES >> GO TO 6

NO >> Replace condenser. Refer to [DEF-53, "Removal and Installation - Coupe"](#) (Coupe) or [DEF-53, "Removal and Installation - Sedan"](#) (Sedan).

6. CHECK HARNESS CONTINUITY 2

1. Remove rear window defogger relay.
2. Check continuity between rear window defogger relay connector B4 (A) terminal 10T, 11T and condenser connector B52 (B) terminal 1.

Fuse block (J/B) connector	Terminal	Condenser connector	Terminal	Continuity
B4	10T	B52	1	Yes
	11T			

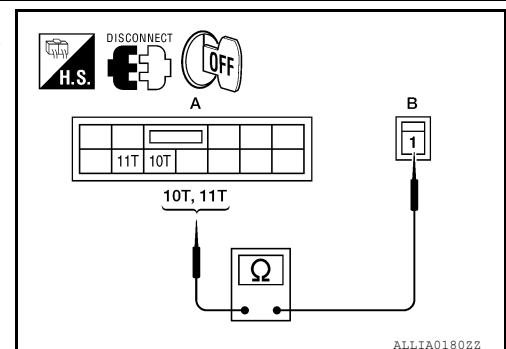

Is the inspection result normal?

YES >> Check intermittent incident. Refer to [GI-42, "Intermittent Incident"](#).

NO >> Replace or repair harness.

REAR WINDOW DEFOGGER POWER SUPPLY AND GROUND CIRCUIT

< DTC/CIRCUIT DIAGNOSIS >

7. CHECK FILAMENT

Check filament.

Refer to [DEF-18, "Component Inspection"](#).

Is the inspection result normal?

YES >> Check intermittent incident. Refer to [GI-42, "Intermittent Incident"](#).

NO >> Repair filament. Refer to [DEF-51, "Inspection and Repair"](#).

Component Inspection

INFOID:000000007422754

1. CHECK FILAMENT

Check the filament for damage or open circuits.

Refer to [DEF-51, "Inspection and Repair"](#).

Is the inspection result normal?

YES >> Inspection End.

NO >> Repair filament. Refer to [DEF-51, "Inspection and Repair"](#).

BCM (BODY CONTROL MODULE)

< ECU DIAGNOSIS INFORMATION >

ECU DIAGNOSIS INFORMATION

BCM (BODY CONTROL MODULE)

Reference Value

INFOID:000000007630954

VALUES ON THE DIAGNOSIS TOOL

Monitor Item	Condition	Value/Status
FR WIPER HI	Other than front wiper switch HI	OFF
	Front wiper switch HI	ON
FR WIPER LOW	Other than front wiper switch LO	OFF
	Front wiper switch LO	ON
FR WASHER SW	Front washer switch OFF	OFF
	Front washer switch ON	ON
FR WIPER INT	Other than front wiper switch INT	OFF
	Front wiper switch INT	ON
FR WIPER STOP	Front wiper is not in STOP position	OFF
	Front wiper is in STOP position	ON
INT VOLUME	Wiper intermittent dial is in a dial position 1 - 6	Wiper intermittent dial position
TURN SIGNAL R	Other than turn signal switch RH	OFF
	Turn signal switch RH	ON
TURN SIGNAL L	Other than turn signal switch LH	OFF
	Turn signal switch LH	ON
TAIL LAMP SW	Other than lighting switch 1ST and 2ND	OFF
	Lighting switch 1ST or 2ND	ON
HI BEAM SW	Other than lighting switch HI	OFF
	Lighting switch HI	ON
HEAD LAMP SW 1	Other than lighting switch 2ND	OFF
	Lighting switch 2ND	ON
HEAD LAMP SW 2	Other than lighting switch 2ND	OFF
	Lighting switch 2ND	ON
PASSING SW	Other than lighting switch PASS	OFF
	Lighting switch PASS	ON
AUTO LIGHT SW	Other than lighting switch AUTO	OFF
	Lighting switch AUTO	ON
FR FOG SW	Front fog lamp switch OFF	OFF
	Front fog lamp switch ON	ON
DOOR SW-DR	Driver door closed	OFF
	Driver door opened	ON
DOOR SW-AS	Passenger door closed	OFF
	Passenger door opened	ON
DOOR SW-RR	Rear RH door closed	OFF
	Rear RH door opened	ON
DOOR SW-RL	Rear LH door closed	OFF
	Rear LH door opened	ON

BCM (BODY CONTROL MODULE)

< ECU DIAGNOSIS INFORMATION >

Monitor Item	Condition	Value/Status
CDL LOCK SW	Other than power door lock switch LOCK	OFF
	Power door lock switch LOCK	ON
CDL UNLOCK SW	Other than power door lock switch UNLOCK	OFF
	Power door lock switch UNLOCK	ON
KEY CYL LK-SW	Other than driver door key cylinder LOCK position	OFF
	Driver door key cylinder LOCK position	ON
KEY CYL UN-SW	Other than driver door key cylinder UNLOCK position	OFF
	Driver door key cylinder UNLOCK position	ON
HAZARD SW	When hazard switch is not pressed	OFF
	When hazard switch is pressed	ON
REAR DEF SW	When rear window defogger switch is pressed	ON
FAN ON SIG	When AUTO switch or fan switch is pressed	ON
AIR COND SW	When A/C switch is pressed	ON
TR CANCEL SW	Trunk lid opener cancel switch OFF	OFF
	Trunk lid opener cancel switch ON	ON
TR/BD OPEN SW	Trunk lid opener switch OFF	OFF
	While the trunk lid opener switch is turned ON	ON
TRNK/HAT MNTR	Trunk lid closed	OFF
	Trunk lid opened	ON
RKE-LOCK	When LOCK button of Intelligent Key is not pressed	OFF
	When LOCK button of Intelligent Key is pressed	ON
RKE-UNLOCK	When UNLOCK button of Intelligent Key is not pressed	OFF
	When UNLOCK button of Intelligent Key is pressed	ON
RKE-TR/BD	When TRUNK OPEN button of Intelligent Key is not pressed	OFF
	When TRUNK OPEN button of Intelligent Key is pressed	ON
RKE-PANIC	When PANIC button of Intelligent Key is not pressed	OFF
	When PANIC button of Intelligent Key is pressed	ON
RKE-P/W OPEN	When UNLOCK button of Intelligent Key is not pressed and held	OFF
	When UNLOCK button of Intelligent Key is pressed and held	ON
RKE-MODE CHG	When LOCK/UNLOCK button of Intelligent Key is not pressed and held simultaneously	OFF
	When LOCK/UNLOCK button of Intelligent Key is pressed and held simultaneously	ON
OPTICAL SENSOR	When outside of the vehicle is bright	Close to 5 V
	When outside of the vehicle is dark	Close to 0 V
REQ SW-DR	When driver door request switch is not pressed	OFF
	When driver door request switch is pressed	ON
REQ SW-AS	When passenger door request switch is not pressed	OFF
	When passenger door request switch is pressed	ON
REQ SW-BD/TR	When trunk request switch is not pressed	OFF
	When trunk request switch is pressed	ON
PUSH SW	When engine switch (push switch) is not pressed	OFF
	When engine switch (push switch) is pressed	ON
IGN RLY -F/B	Ignition switch OFF or ACC	OFF
	Ignition switch ON	ON

BCM (BODY CONTROL MODULE)

< ECU DIAGNOSIS INFORMATION >

Monitor Item	Condition	Value/Status	
ACC RLY -F/B	Ignition switch OFF	OFF	A
	Ignition switch ACC or ON	ON	
CLUTCH SW	When the clutch pedal is not depressed	OFF	B
	When the clutch pedal is depressed	ON	
BRAKE SW 1	When the brake pedal is not depressed	ON	C
	When the brake pedal is depressed	OFF	
DETE/CANCL SW	When selector lever is in P position	OFF	D
	When selector lever is in any position other than P	ON	
SFT PN/N SW	When selector lever is in any position other than P or N	OFF	E
	When selector lever is in P or N position	ON	
S/L -LOCK	Electronic steering column lock LOCK status	OFF	F
	Electronic steering column lock UNLOCK status	ON	
S/L -UNLOCK	Electronic steering column lock UNLOCK status	OFF	G
	Electronic steering column lock LOCK status	ON	
S/L RELAY-F/B	Ignition switch OFF or ACC	OFF	H
	Ignition switch ON	ON	
UNLK SEN-DR	Driver door UNLOCK status	OFF	I
	Driver door LOCK status	ON	
PUSH SW -IPDM	When engine switch (push switch) is not pressed	OFF	J
	When engine switch (push switch) is pressed	ON	
IGN RLY1 F/B	Ignition switch OFF or ACC	OFF	K
	Ignition switch ON	ON	
DETE SW -IPDM	When selector lever is in P position	OFF	DEF
	When selector lever is in any position other than P	ON	
SFT PN -IPDM	When selector lever is in any position other than P or N	OFF	M
	When selector lever is in P or N position	ON	
SFT P -MET	When selector lever is in any position other than P	OFF	N
	When selector lever is in P position	ON	
SFT N -MET	When selector lever is in any position other than N	OFF	O
	When selector lever is in N position	ON	
ENGINE STATE	Engine stopped	STOP	P
	While the engine stalls	STALL	
	At engine cranking	CRANK	
	Engine running	RUN	
S/L LOCK-IPDM	Electronic steering column lock LOCK status	OFF	
	Electronic steering column lock UNLOCK status	ON	
S/L UNLCK-IPDM	Electronic steering column lock UNLOCK status	OFF	
	Electronic steering column lock LOCK status	ON	
S/L RELAY-REQ	Ignition switch OFF or ACC	OFF	
	Ignition switch ON	ON	
VEH SPEED 1	While driving	Equivalent to speedometer reading	
VEH SPEED 2	While driving	Equivalent to speedometer reading	

BCM (BODY CONTROL MODULE)

< ECU DIAGNOSIS INFORMATION >

Monitor Item	Condition	Value/Status
DR DOOR STATE	Driver door LOCK status	LOCK
	Wait with selective UNLOCK operation (5 seconds)	READY
	Driver door UNLOCK status	UNLK
AS DOOR STATE	Passenger door LOCK status	LOCK
	Wait with selective UNLOCK operation (5 seconds)	READY
	Passenger door UNLOCK status	UNLK
ID OK FLAG	Ignition switch ACC or ON	RESET
	Ignition switch OFF	SET
PRMT ENG STAT	When the engine start is prohibited	RESET
	When the engine start is permitted	SET
KEY SW -SLOT	When Intelligent Key is not inserted into key slot	OFF
	When Intelligent Key is inserted into key slot	ON
RKE OPE COUN1	During the operation of Intelligent Key	Operation frequency of Intelligent Key
AIR PRESS FL	Ignition switch ON (only when the signal from the transmitter is received)	Air pressure of front LH tire
AIR PRESS FR	Ignition switch ON (only when the signal from the transmitter is received)	Air pressure of front RH tire
AIR PRESS RR	Ignition switch ON (only when the signal from the transmitter is received)	Air pressure of rear RH tire
AIR PRESS RL	Ignition switch ON (only when the signal from the transmitter is received)	Air pressure of rear LH tire
ID REGST FL1	When ID of front LH tire transmitter is registered	DONE
	When ID of front LH tire transmitter is not registered	YET
ID REGST FR1	When ID of front RH tire transmitter is registered	DONE
	When ID of front RH tire transmitter is not registered	YET
ID REGST RR1	When ID of rear RH tire transmitter is registered	DONE
	When ID of rear RH tire transmitter is not registered	YET
ID REGST RL1	When ID of rear LH tire transmitter is registered	DONE
	When ID of rear LH tire transmitter is not registered	YET
WARNING LAMP	Tire pressure indicator OFF	OFF
	Tire pressure indicator ON	ON

BCM (BODY CONTROL MODULE)

< ECU DIAGNOSIS INFORMATION >

Terminal Layout

INFOID:000000007630955

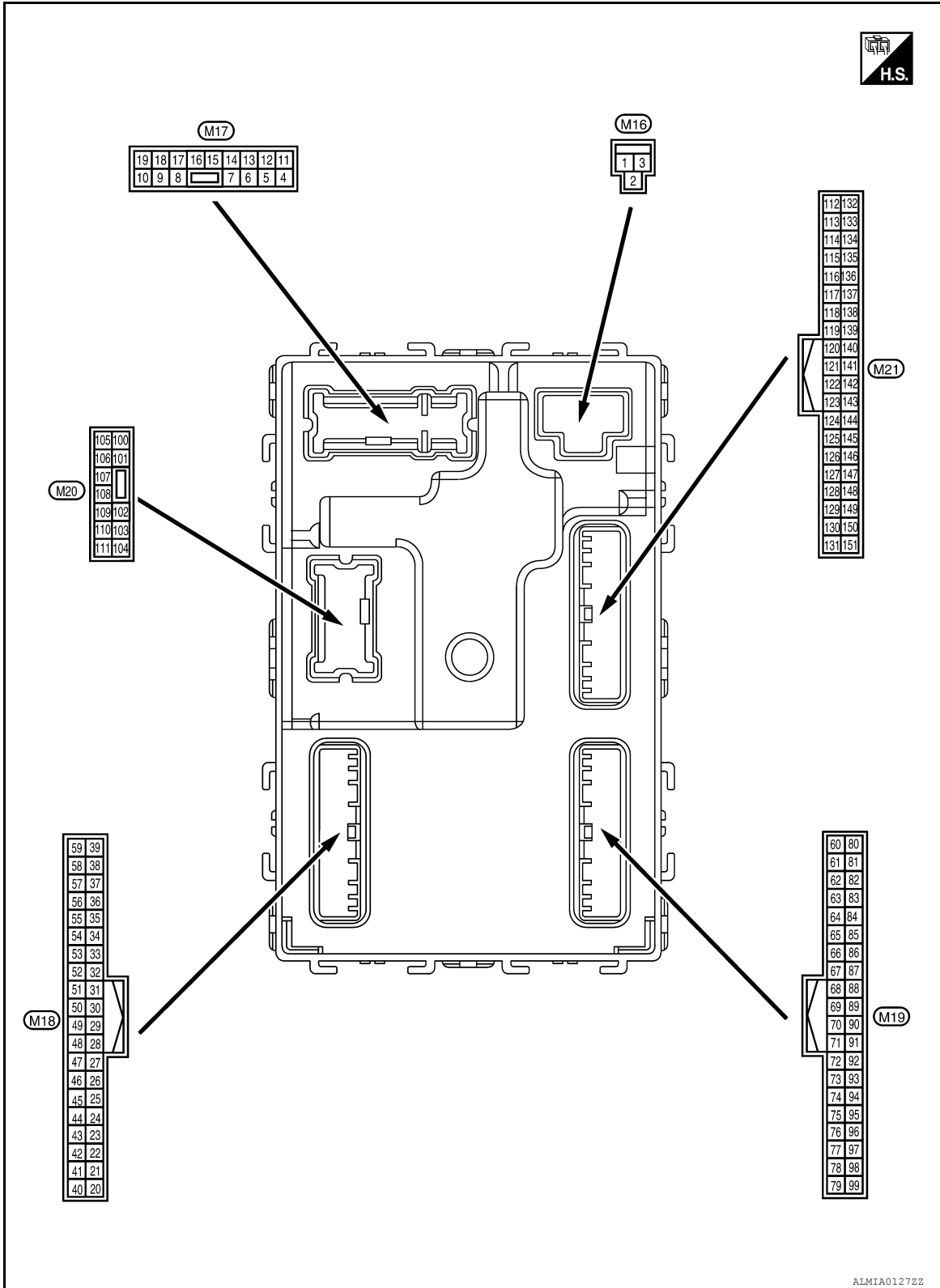

A
B
C
D
E
F
G
H
I
J
K
DEF
M
N
O
P

Physical Values

INFOID:000000007630956

BCM (BODY CONTROL MODULE)

< ECU DIAGNOSIS INFORMATION >

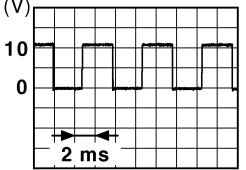
Terminal No. (Wire color)		Description		Condition		Value (Approx.)
(+)	(-)	Signal name	Input/ Output			
1 (W/B)	Ground	Battery power supply	Input	Ignition switch OFF		Battery voltage
2 (R/Y)	Ground	Battery power supply output	Output	Ignition switch OFF		Battery voltage
3 (L/W)	Ground	Ignition power supply output	Output	Ignition switch ON		Battery voltage
4 (P/W)	Ground	Interior room lamp power supply	Output	After passing the interior room lamp battery saver operation time		0V
				Any other time after passing the interior room lamp battery saver operation time		Battery voltage
5 (G/Y)	Ground	Front door RH UNLOCK	Output	Front door RH	UNLOCK (actuator is activated)	Battery voltage
					Other than UNLOCK (actuator is not activated)	0V
7 (R/W)	Ground	Step lamp	Output	Step lamp	ON	0V
					OFF	Battery voltage
8 (V)	Ground	All doors LOCK	Output	All doors	LOCK (actuator is activated)	Battery voltage
						Other than LOCK (actuator is not activated)
9 (G)	Ground	Front door LH UNLOCK	Output	Front door LH	UNLOCK (actuator is activated)	Battery voltage
						Other than UNLOCK (actuator is not activated)
10 ¹ (G/Y)	Ground	Rear door RH and rear door LH UNLOCK	Output	Rear door RH and rear door LH	UNLOCK (actuator is activated)	Battery voltage
						Other than UNLOCK (actuator is not activated)
11 (Y/R)	Ground	Battery power supply	Input	Ignition switch OFF		Battery voltage
13 (B)	Ground	Ground	—	Ignition switch ON		0V
14 ¹ (O/W)	Ground	Engine switch (push switch) illumination ground	Input	Tail lamp	OFF	0V
					ON	<p>NOTE: When the illumination brightening/dimming level is in the neutral position</p>  <p style="text-align: right; font-size: small;">JSNIA0010GB</p>

BCM (BODY CONTROL MODULE)

< ECU DIAGNOSIS INFORMATION >

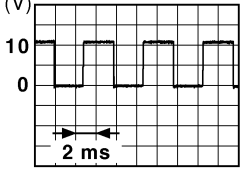
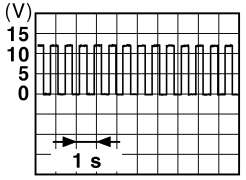
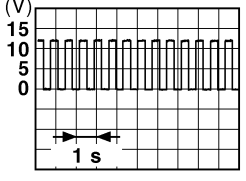
Terminal No. (Wire color)		Description		Condition	Value (Approx.)	
(+)	(-)	Signal name	Input/ Output			
14 ⁸ (R/Y)	Ground	Engine switch (push switch) illumination ground	Input	Tail lamp	OFF	0V
					ON	NOTE: When the illumination brightening/dimming level is in the neutral position  <small>JSN1A0010GB</small>
15 (Y/L)	Ground	ACC indicator lamp	Output	Ignition switch	OFF	Battery voltage
					ACC	0V
17 (G/B)	Ground	Turn signal (RH)	Output	Ignition switch ON	Turn signal switch OFF	0V
					Turn signal switch RH	 <small>PKID0926E</small> 6.5 V
18 (G/Y)	Ground	Turn signal (LH)	Output	Ignition switch ON	Turn signal switch OFF	0V
					Turn signal switch LH	 <small>PKID0926E</small> 6.5 V
19 (Y)	Ground	Room lamp timer control	Output	Interior room lamp	OFF	Battery voltage
					ON	0V
21 (P/B)	Ground	Optical sensor signal	Input	Ignition switch ON	When outside of the vehicle is bright	Close to 5V
					When outside of the vehicle is dark	Close to 0V
22 ² (R/Y)	Ground	Clutch interlock switch	Input	Clutch interlock switch	OFF (clutch pedal is not depressed)	0V
					ON (clutch pedal is depressed)	Battery voltage
24 (R/W)	Ground	Stop lamp switch 1	Input	—	Battery voltage	
26 (O/L)	Ground	Stop lamp switch 2	Input	Stop lamp switch	OFF (brake pedal is not depressed)	0V
					ON (brake pedal is depressed)	Battery voltage

A
B
C
D
E
F
G
H
I
J
K
DEF
M
N
O
P

BCM (BODY CONTROL MODULE)

< ECU DIAGNOSIS INFORMATION >

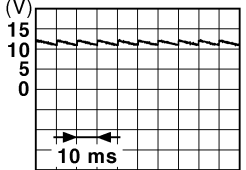
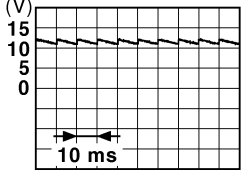
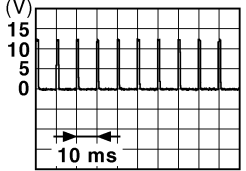
Terminal No. (Wire color)		Description		Condition		Value (Approx.)
(+)	(-)	Signal name	Input/ Output			
27 (G/W)	Ground	Front door lock as- sembly LH (unlock sensor)	Input	Front door LH	LOCK status	 <small>JPMIA0011GB</small> 11.8V
					UNLOCK status	0V
29 (Y)	Ground	Key slot switch	Input	When Intelligent Key is inserted into key slot		Battery voltage
				When Intelligent Key is not inserted into key slot		0V
30 (V/Y)	Ground	ACC feedback signal	Input	Ignition switch	OFF	0
					ACC or ON	Battery voltage
31 (G)	Ground	Rear window defog- ger feedback signal	Input	Rear window de- fogger switch	OFF	0V
					ON	Battery voltage
32 (R/B)	Ground	Front door RH switch	Input	Front door RH switch	OFF (when front door RH closes)	 <small>JPMIA0011GB</small> 11.8 V
					ON (when front door RH opens)	0V
33 (SB)	Ground	Compressor ON sig- nal	Input	A/C switch	OFF	9V - 12V
					ON	0V
34 ³ (L/R)	Ground	Front door lock as- sembly LH (key cylin- der switch) (unlock)	Input	Front door lock assembly LH (key cylinder switch)	OFF (neutral)	Battery voltage
					ON (unlock)	0V
36 ³ (GR)	Ground	Lock switch signal	Input	Door lock/unlock switch	Lock	Battery voltage
					Unlock	0V
37 (O)	Ground	Trunk lid opener can- cel switch	Input	Trunk lid opener cancel switch	CANCEL	 <small>JPMIA0012GB</small> 1.1V
					ON	0V
38 (GR/ W)	Ground	Rear window defog- ger ON signal	Input	Rear window de- fogger switch	OFF	Battery voltage
					ON	0V
39 ³ (GR/ R)	Ground	Unlock switch signal	Input	Door lock/unlock switch	Unlock	Battery voltage
					Lock	0V

BCM (BODY CONTROL MODULE)

< ECU DIAGNOSIS INFORMATION >

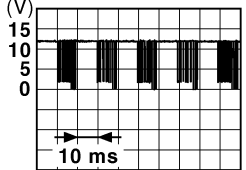
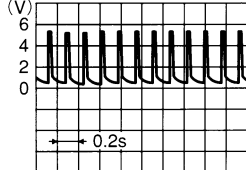
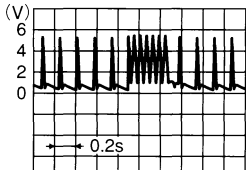
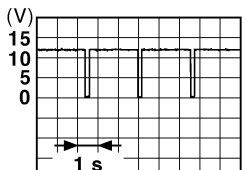
Terminal No. (Wire color)		Description		Condition		Value (Approx.)	
(+)	(-)	Signal name	Input/ Output				
40 ⁴ (Y/G)	Ground	Power window serial link	Input/ Output	Ignition switch ON		10.2V	
				Ignition switch OFF or ACC	0V		
41 (W)	Ground	Engine switch (push switch) illumination	Output	Engine switch (push switch) illumination	ON	5.5V	
				OFF	0V		
42 (R)	Ground	LOCK indicator lamp	Output	LOCK indicator lamp	ON	0V	
				OFF	Battery voltage		
45 (P)	Ground	Receiver & sensor ground	Input	Ignition switch ON		0V	
46 (V/W)	Ground	Receiver & sensor power supply output	Output	Ignition switch	OFF	0V	
				ACC or ON	5.0V		
47 (G/O)	Ground	Tire pressure receiver signal	Input/ Output	Ignition switch ON	Standby state		
				When receiving the signal from the transmitter			
48 (R/G)	Ground	Selector lever P/N position signal	Input	Selector lever	P or N position	12.0V	
				Except P and N positions	0V		
49 (L/O)	Ground	Security indicator signal	Output	Security indicator	Blinking		11.3V
				OFF	Battery voltage		

A
B
C
D
E
F
G
H
I
J
K
M
N
O
P

DEF

BCM (BODY CONTROL MODULE)

< ECU DIAGNOSIS INFORMATION >

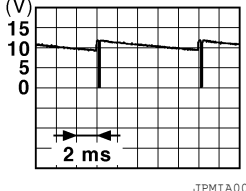
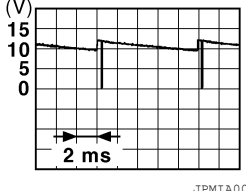
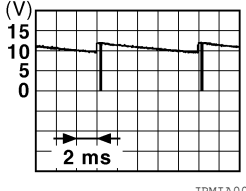
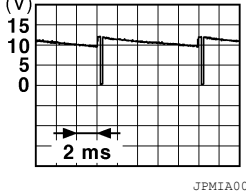
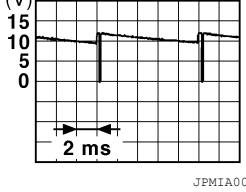
Terminal No. (Wire color)		Description		Condition	Value (Approx.)
(+)	(-)	Signal name	Input/ Output		
50 (LG/ B)	Ground	Combination switch OUTPUT 5	Input	Combination switch (Wiper intermittent dial 4)	0V
				All switch OFF	
				Lighting switch 1ST	
				Lighting switch high-beam	
Lighting switch 2ND					
				Turn signal switch RH	10.7V
51 (L/W)	Ground	Combination switch OUTPUT 1	Input	Combination switch	0V
				All switch OFF (Wiper intermittent dial 4)	
				Front wiper switch HI (Wiper intermittent dial 4)	
				Any of the conditions below with all switch OFF	
<ul style="list-style-type: none"> • Wiper intermittent dial 1 • Wiper intermittent dial 2 • Wiper intermittent dial 3 • Wiper intermittent dial 6 • Wiper intermittent dial 7 					
				10.7V	
52 (G/B)	Ground	Combination switch OUTPUT 2	Input	Combination switch	0V
				All switch OFF (Wiper intermittent dial 4)	
				Front washer switch ON (Wiper intermittent dial 4)	
				Any of the conditions below with all switch OFF	
<ul style="list-style-type: none"> • Wiper intermittent dial 1 • Wiper intermittent dial 5 • Wiper intermittent dial 6 					
				10.7V	
53 (LG/ R)	Ground	Combination switch OUTPUT 3	Input	Combination switch (Wiper intermittent dial 4)	0V
				All switch OFF	
				Front wiper switch INT	
				Front wiper switch LO	
Lighting switch AUTO					
				10.7V	
54 (G/Y)	Ground	Combination switch OUTPUT 4	Input	Combination switch (Wiper intermittent dial 4)	0V
				All switch OFF	
				Front fog lamp switch ON	
				Lighting switch 2ND	
Lighting switch flash-to-pass					
				Turn signal switch LH	10.7V
55 (BR/ W)	Ground	Front blower monitor	Input	Front blower motor switch	Battery voltage
				ON	0V
				OFF	0V

BCM (BODY CONTROL MODULE)

< ECU DIAGNOSIS INFORMATION >

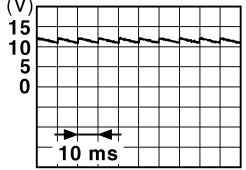
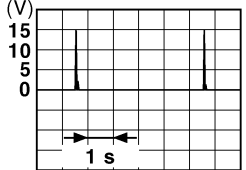
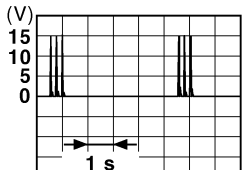
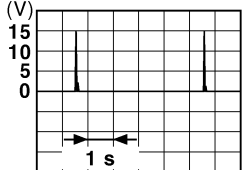
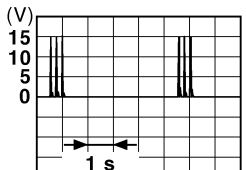
Terminal No. (Wire color)		Description		Condition		Value (Approx.)
(+)	(-)	Signal name	Input/ Output			
56 ³ (L/B)	Ground	Front door lock assembly LH (key cylinder switch) (lock)	Input	Front door lock assembly LH (key cylinder switch)	OFF (neutral)	Battery voltage
					ON (lock)	0V
57 (W)	Ground	Tire pressure warning check switch	Input	—		Battery voltage
58 (SB)	Ground	Front door LH switch	Input	Front door LH switch	OFF (front door LH CLOSE)	 <p style="text-align: right; margin-right: 50px;">11.8V</p>
					ON (front door LH OPEN)	0V
59 (G/R)	Ground	Rear window defogger relay	Output	Rear window defogger	Active	Battery voltage
					Not activated	0V
60 (B/R)	Ground	Front console antenna 2 (-)	Output	Ignition switch OFF	When Intelligent Key is in the passenger compartment	
					When Intelligent Key is not in the passenger compartment	
61 (W/R)	Ground	Center console antenna 2 (+)	Output	Ignition switch OFF	When Intelligent Key is in the passenger compartment	
					When Intelligent Key is not in the passenger compartment	

A
B
C
D
E
F
G
H
I
J
K
DEF
M
N
O
P



BCM (BODY CONTROL MODULE)

< ECU DIAGNOSIS INFORMATION >

Terminal No. (Wire color)		Description		Condition	Value (Approx.)
(+)	(-)	Signal name	Input/ Output		
62 (B/Y)	Ground	Front outside handle RH antenna (-)	Output	When Intelligent Key is in the antenna detection area	<p style="text-align: right; font-size: small;">JMKIA0062GB</p>
				When the front door RH request switch is operat- ed with ignition switch OFF	<p style="text-align: right; font-size: small;">JMKIA0063GB</p>
63 (LG)	Ground	Front outside handle RH antenna (+)	Output	When Intelligent Key is in the antenna detection area	<p style="text-align: right; font-size: small;">JMKIA0062GB</p>
				When the front door RH request switch is operat- ed with ignition switch OFF	<p style="text-align: right; font-size: small;">JMKIA0063GB</p>
64 (V)	Ground	Front outside handle LH antenna (-)	Output	When Intelligent Key is in the antenna detection area	<p style="text-align: right; font-size: small;">JMKIA0062GB</p>
				When the front door LH request switch is operat- ed with ignition switch OFF	<p style="text-align: right; font-size: small;">JMKIA0063GB</p>

BCM (BODY CONTROL MODULE)



< ECU DIAGNOSIS INFORMATION >

Terminal No. (Wire color)		Description		Condition	Value (Approx.)	
(+)	(-)	Signal name	Input/ Output			
65 (P)	Ground	Front outside handle LH antenna (+)	Output	When the front door LH request switch is operat- ed with ignition switch OFF	<p style="text-align: right; font-size: small;">JMKIA0062GB</p>	
				When Intelligent Key is not in the antenna detection area	<p style="text-align: right; font-size: small;">JMKIA0063GB</p>	
68 (G/O)	Ground	NATS antenna amp (built in key slot)	Input/ Output	During waiting	Ignition switch is pressed while inserting the Intelli- gent Key into the key slot.	Just after pressing ignition switch. Pointer of tester should move.
69 (O)	Ground	NATS antenna amp (built in key slot)	Input/ Output	During waiting	Ignition switch is pressed while inserting the Intelli- gent Key into the key slot.	Just after pressing ignition switch. Pointer of tester should move.
70 (R/B)	Ground	Ignition relay-2 con- trol	Output	Ignition switch	OFF or ACC	0V
					ON	Battery voltage
71 (L/O)	Ground	Remote keyless entry receiver signal	Input/ Output	During waiting	<p style="text-align: right; font-size: small;">JMKIA0064GB</p>	
				When operating either button on Intelligent Key	<p style="text-align: right; font-size: small;">JMKIA0065GB</p>	

A
B
C
D
E
F
G
H
I
J
K
DEF
M
N
O
P

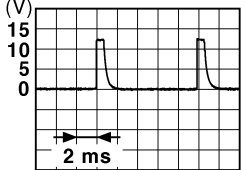

BCM (BODY CONTROL MODULE)

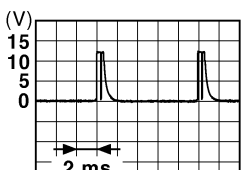
< ECU DIAGNOSIS INFORMATION >

Terminal No. (Wire color)		Description		Condition	Value (Approx.)
(+)	(-)	Signal name	Input/ Output		
75 (R/Y)	Ground	Combination switch INPUT 5	Output	Combination switch	<p>All switch OFF (Wiper intermittent dial 4)</p>  <p style="text-align: right; font-size: small;">JPMIA0041GB</p> <p style="text-align: center;">1.4V</p>
				Combination switch	<p>Front fog lamp switch ON (Wiper intermittent dial 4)</p>  <p style="text-align: right; font-size: small;">JPMIA0037GB</p> <p style="text-align: center;">1.3V</p>
				Combination switch	<p>Any of the conditions below with all switch OFF</p> <ul style="list-style-type: none"> • Wiper intermittent dial 1 • Wiper intermittent dial 2 • Wiper intermittent dial 6 • Wiper intermittent dial 7  <p style="text-align: right; font-size: small;">JPMIA0040GB</p> <p style="text-align: center;">1.3V</p>

BCM (BODY CONTROL MODULE)

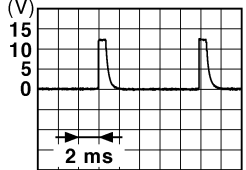
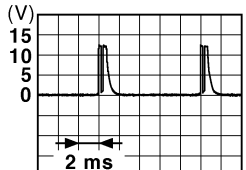
< ECU DIAGNOSIS INFORMATION >

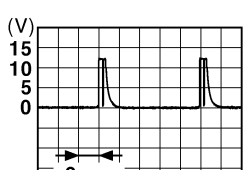
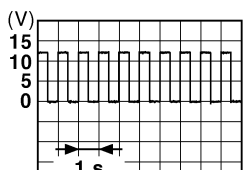
Terminal No. (Wire color)		Description		Condition	Value (Approx.)
(+)	(-)	Signal name	Input/ Output		
76 (R/G)	Ground	Combination switch INPUT 3	Output	Combination switch	All switch OFF (Wiper intermittent dial 4)  1.4V
					Lighting switch high-beam (Wiper intermittent dial 4)  1.3V
					Lighting switch 2ND (Wiper intermittent dial 4)  1.3V
					Any of the conditions below with all switch OFF • Wiper intermittent dial 1 • Wiper intermittent dial 2 • Wiper intermittent dial 3  1.3V
77 (BR)	Ground	Engine switch (push switch)	Input	Engine switch (push switch)	Pressed 0V Not pressed Battery voltage
78 (P)	Ground	CAN-L	Input/ Output	—	—
79 (L)	Ground	CAN-H	Input/ Output	—	—
80 (R/L)	Ground	Key slot illumination	Output	Key slot illumina- tion	OFF 0V
					Blinking  6.5V
				ON	Battery voltage

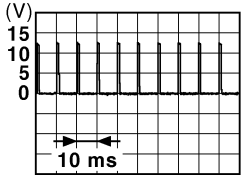
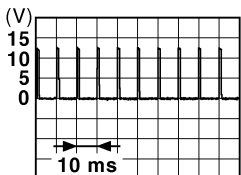

BCM (BODY CONTROL MODULE)

< ECU DIAGNOSIS INFORMATION >

Terminal No. (Wire color)		Description		Condition		Value (Approx.)
		Signal name	Input/ Output			
(+)	(-)					
81 (LG)	Ground	ON indicator lamp	Output	Ignition switch	OFF or ACC	Battery voltage
					ON	0V
83 (L)	Ground	ACC relay-1 control	Output	Ignition switch	OFF	0V
					ACC or ON	Battery voltage
84 ⁵ (Y/R)	Ground	CVT shift selector	Output	—		Battery voltage
85 (L/O)	Ground	Electronic steering column lock condition No. 1	Input	Electronic steer- ing column lock	Lock status	0V
					Unlock status	Battery voltage
86 (G/R)	Ground	Electronic steering column lock condition No. 2	Input	Electronic steer- ing column lock	Lock status	Battery voltage
					Unlock status	0V
87 ⁵ (G/B)	Ground	Selector lever P posi- tion switch	Input	Selector lever	P position	0V
					Any position other than P	Battery voltage
88 (P/L)	Ground	Front door RH re- quest switch	Input	Front door RH re- quest switch	ON (pressed)	0V
					OFF (not pressed)	 <p style="text-align: right; font-size: small;">JPMIA0016GB 1.0V</p>
89 (B/W)	Ground	Front door LH re- quest switch	Input	Front door LH re- quest switch	ON (pressed)	0V
					OFF (not pressed)	 <p style="text-align: right; font-size: small;">JPMIA0016GB 1.0V</p>
90 (Y)	Ground	Blower fan motor re- lay control	Output	Ignition switch	OFF or ACC	0V
					ON	Battery voltage
91 (L/R)	Ground	Remote keyless entry receiver power sup- ply	Output	Ignition switch OFF		Battery voltage
94 (G/Y)	Ground	Electronic steering column lock power supply	Output	Ignition switch	OFF or ACC	Battery voltage
					ON	0V

BCM (BODY CONTROL MODULE)

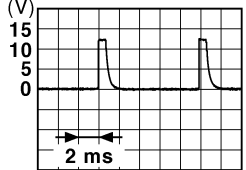
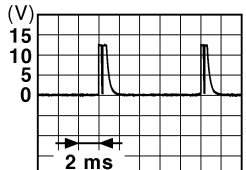
< ECU DIAGNOSIS INFORMATION >

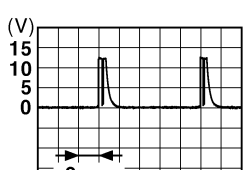
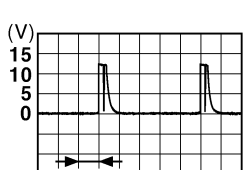
Terminal No. (Wire color)		Description		Condition	Value (Approx.)
(+)	(-)	Signal name	Input/ Output		
95 (R/W)	Ground	Combination switch INPUT 1	Output	Combination switch (Wiper intermittent dial 4)	All switch OFF  1.4V
					Turn signal switch LH  1.3V
					Turn signal switch RH  1.3V
					Front wiper switch LO  1.3V
					Front washer switch ON  1.3V

A
B
C
D
E
F
G
H
I
J
K
DEF
M
N
O
P

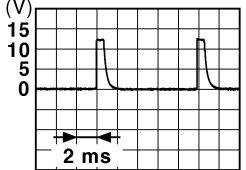
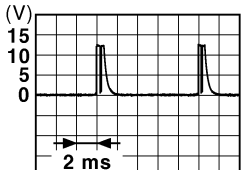
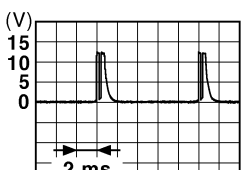
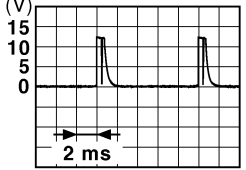

BCM (BODY CONTROL MODULE)

< ECU DIAGNOSIS INFORMATION >

Terminal No. (Wire color)		Description		Condition	Value (Approx.)
(+)	(-)	Signal name	Input/ Output		
96 (P/B)	Ground	Combination switch INPUT 4	Output Combination switch	All switch OFF (Wiper intermittent dial 4)	 <p style="text-align: right; font-size: small;">JPMIA0041GB</p> <p style="text-align: center;">1.4V</p>
				Lighting switch AUTO (Wiper intermittent dial 4)	 <p style="text-align: right; font-size: small;">JPMIA0038GB</p> <p style="text-align: center;">1.3V</p>
				Lighting switch 1ST (Wiper intermittent dial 4)	 <p style="text-align: right; font-size: small;">JPMIA0036GB</p> <p style="text-align: center;">1.3V</p>
				Any of the conditions below with all switch OFF	<ul style="list-style-type: none"> • Wiper intermittent dial 1 • Wiper intermittent dial 5 • Wiper intermittent dial 6  <p style="text-align: right; font-size: small;">JPMIA0039GB</p> <p style="text-align: center;">1.3V</p>

BCM (BODY CONTROL MODULE)

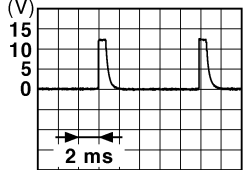
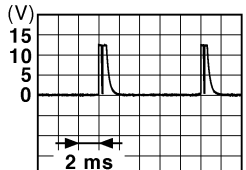
< ECU DIAGNOSIS INFORMATION >

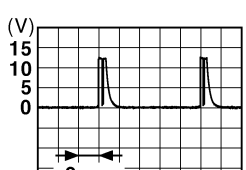
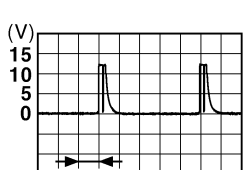
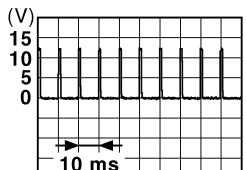
Terminal No. (Wire color)		Description		Condition	Value (Approx.)	A	
(+)	(-)	Signal name	Input/ Output			B	
97 (R/B)	Ground	Combination switch INPUT 2	Output	Combination switch (Wiper intermittent dial 4)	All switch OFF	 1.4V	C
					Lighting switch flash-to-pass	 1.3V	D
					Lighting switch 2ND	 1.3V	E
					Front wiper switch INT	 1.3V	F
					Front wiper switch HI	 1.3V	G
					Pressed	0 V	H
98 (G/O)	Ground	Hazard switch	Input	Hazard switch	Not pressed	 1.1V	I
					J		

DEF

BCM (BODY CONTROL MODULE)

< ECU DIAGNOSIS INFORMATION >

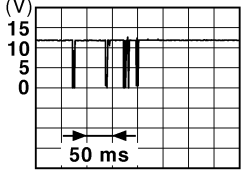
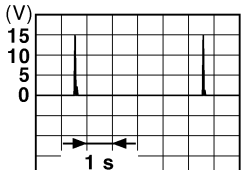
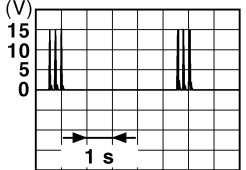
Terminal No. (Wire color)		Description		Condition	Value (Approx.)	
(+)	(-)	Signal name	Input/ Output			
99 (L/Y)	Ground	Electronic steering column lock unit com- munication	Input/ Output	Electronic steer- ing column lock	LOCK status	Battery voltage
					LOCK or UNLOCK	 <p style="text-align: right; font-size: small;">JMKIA0066GB</p>
					For 15 seconds after UN- LOCK	Battery voltage
				15 seconds or later after UNLOCK	0V	
103 (V)	Ground	Trunk lid opening	Output	Trunk lid	Open (trunk lid opener ac- tuator is activated)	Battery voltage
					Close (trunk lid opener ac- tuator is not activated)	0V
110 (V/W)	Ground	Trunk room lamp	Output	Trunk room lamp	ON	0V
					OFF	Battery voltage
114 (B)	Ground	Trunk room antenna 1 (-)	Output	Ignition switch OFF	When Intelligent Key is in the passenger compart- ment	 <p style="text-align: right; font-size: small;">JMKIA0062GB</p>
					When Intelligent Key is not in the passenger compart- ment	 <p style="text-align: right; font-size: small;">JMKIA0063GB</p>

BCM (BODY CONTROL MODULE)

< ECU DIAGNOSIS INFORMATION >

Terminal No. (Wire color)		Description		Condition	Value (Approx.)
(+)	(-)	Signal name	Input/ Output		
115 (W)	Ground	Trunk room antenna 1 (+)	Output	Ignition switch OFF	<p style="text-align: right; font-size: small;">JMKIA0062GB</p>
				When Intelligent Key is not in the passenger compart- ment	<p style="text-align: right; font-size: small;">JMKIA0063GB</p>
118 (L/O)	Ground	Rear bumper anten- na (-)	Output	When the trunk lid request switch is operated with ignition switch OFF	<p style="text-align: right; font-size: small;">JMKIA0062GB</p>
				When Intelligent Key is not in the antenna detection area	<p style="text-align: right; font-size: small;">JMKIA0063GB</p>
119 (BR/ W)	Ground	Rear bumper anten- na (+)	Output	When the trunk lid request switch is operated with ignition switch OFF	<p style="text-align: right; font-size: small;">JMKIA0062GB</p>
				When Intelligent Key is not in the antenna detection area	<p style="text-align: right; font-size: small;">JMKIA0063GB</p>

A
B
C
D
E
F
G
H
I
J
K
DEF
M
N
O
P

BCM (BODY CONTROL MODULE)

< ECU DIAGNOSIS INFORMATION >

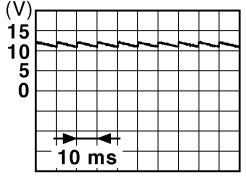
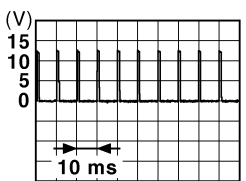
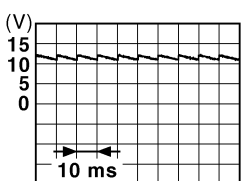
Terminal No. (Wire color)		Description		Condition		Value (Approx.)
(+)	(-)	Signal name	Input/ Output			
127 (BR/ W)	Ground	Ignition relay (IPDM E/R) control	Output	Ignition switch	OFF or ACC	Battery voltage
					ON	0V
130 (Y/G)	Ground	Trunk room lamp switch	Input	Trunk room lamp switch	OFF (trunk is closed)	 <p style="text-align: right; font-size: small;">JPMIA0011GB</p> <p style="text-align: center;">11.8V</p>
					ON (trunk is open)	0V
132 (R)	Ground	Starter motor relay control	Output	Ignition switch OFF (M/T vehi- cle)	When the clutch pedal is depressed	Battery voltage
					When the clutch pedal is not depressed	0V
				Ignition switch ON (other than M/ T vehicle)	When selector lever is in P or N position and the brake is depressed	Battery voltage
					When selector lever is in P or N position and the brake is not depressed	0V
141 (G/R)	Ground	Trunk request switch	Input	Trunk request switch	ON (pressed)	0V
					OFF (not pressed)	 <p style="text-align: right; font-size: small;">JPMIA0016GB</p> <p style="text-align: center;">1.0V</p>
144 (GR)	Ground	Request switch buzz- er	Output	Request switch buzzer	Sounding	0V
					Not sounding	Battery voltage
147 (L/R)	Ground	Trunk lid opener switch	Input	Trunk lid opener switch	Pressed	0V
					Not pressed	Battery voltage
148 ¹ (R/W)	Ground	Rear door RH switch	Input	Rear door RH switch	OFF (when rear door RH closes)	 <p style="text-align: right; font-size: small;">JPMIA0011GB</p> <p style="text-align: center;">11.8V</p>
					ON (when rear door RH opens)	0V

BCM (BODY CONTROL MODULE)

< ECU DIAGNOSIS INFORMATION >

Terminal No. (Wire color)		Description		Condition	Value (Approx.)
(+)	(-)	Signal name	Input/ Output		
149 ¹ (R/B)	Ground	Rear door LH switch	Input	Rear door LH switch	OFF (when rear door LH closes)
				ON (when rear door LH opens)	0V

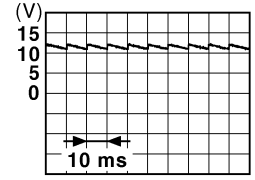

- 1: Sedan only
- 2: M/T only
- 3: With LH front window anti-pinch
- 4: With LH and RH front window anti-pinch.
- 5: CVT only
- 6: With auto lights
- 7: With low tire pressure warning system
- 8: Coupe only

A
B
C
D
E
F
G
H
I
J
K
L
M
N
O
P

DEF

REAR WINDOW DEFOGGER

< WIRING DIAGRAM >

WIRING DIAGRAM

REAR WINDOW DEFOGGER

Wiring Diagram

INFOID:000000007422758

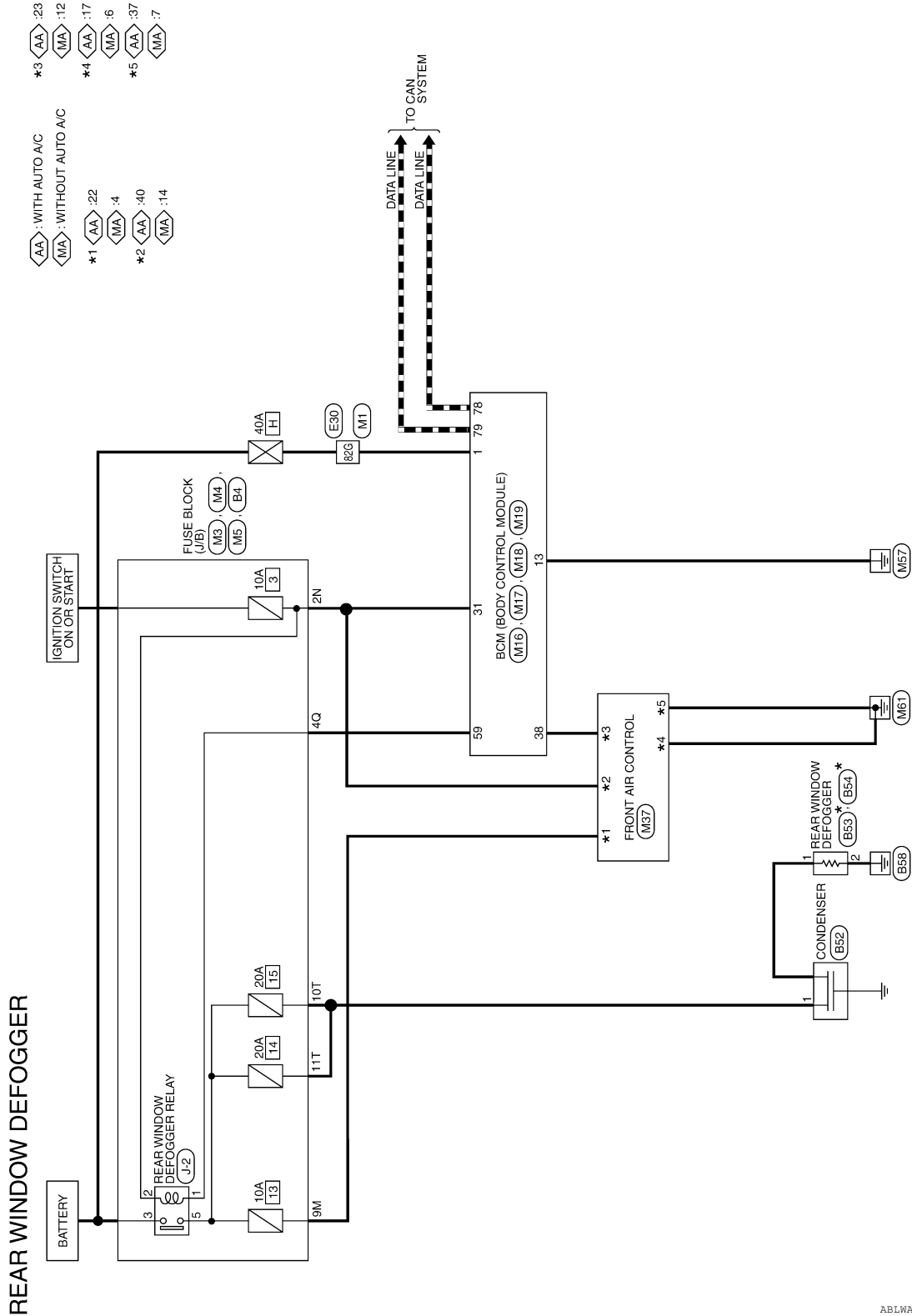

* : THIS CONNECTOR IS NOT SHOWN IN "HARNES LAYOUT" OF PG SECTION.

ABLWA0791GB

REAR WINDOW DEFOGGER

< WIRING DIAGRAM >

REAR WINDOW DEFOGGER CONNECTORS

Connector No.	M1
Connector Name	WIRE TO WIRE
Connector Color	WHITE

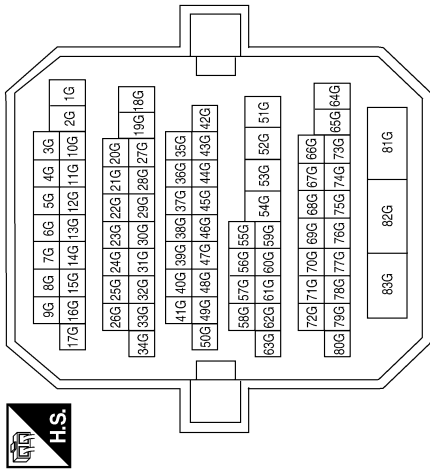

Terminal No.	82G	Color of Wire	W/B	Signal Name	-
--------------	-----	---------------	-----	-------------	---

Connector No.	M3
Connector Name	FUSE BLOCK (J/B)
Connector Color	WHITE



Terminal No.	2N	Color of Wire	G	Signal Name	-
--------------	----	---------------	---	-------------	---

Connector No.	M4
Connector Name	FUSE BLOCK (J/B)
Connector Color	WHITE

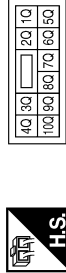

Terminal No.	4Q	Color of Wire	G/R	Signal Name	-
--------------	----	---------------	-----	-------------	---

Connector No.	M5
Connector Name	FUSE BLOCK (J/B)
Connector Color	WHITE

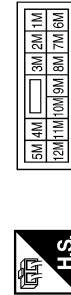

Terminal No.	9M	Color of Wire	GR	Signal Name	-
--------------	----	---------------	----	-------------	---

Connector No.	M16
Connector Name	BCM (BODY CONTROL MODULE)
Connector Color	BLACK



Terminal No.	1	Color of Wire	W/B	Signal Name	BAT_POWER_F/L
--------------	---	---------------	-----	-------------	---------------

Connector No.	M17
Connector Name	BCM (BODY CONTROL MODULE)
Connector Color	WHITE



Terminal No.	13	Color of Wire	B	Signal Name	GND1
--------------	----	---------------	---	-------------	------

ABLIA2269GB

A
B
C
D
E
F
G
H
I
J
K
DEF
M
N
O
P

REAR WINDOW DEFOGGER

< WIRING DIAGRAM >

Connector No.	M37
Connector Name	FRONT AIR CONTROL (WITHOUT AUTO A/C)
Connector Color	WHITE

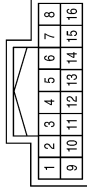

Terminal No.	Color of Wire	Signal Name
4	GR	RR DEF F/B
6	B	GND
7	B	GND (POWER)
12	GR/W	RR DEF ON
14	G	IGN

Connector No.	M19
Connector Name	BCM (BODY CONTROL MODULE)
Connector Color	BLACK

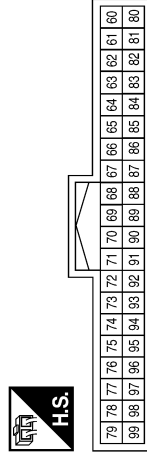

Terminal No.	Color of Wire	Signal Name
78	P	CAN-L
79	L	CAN-H

Connector No.	M18
Connector Name	BCM (BODY CONTROL MODULE)
Connector Color	GREEN

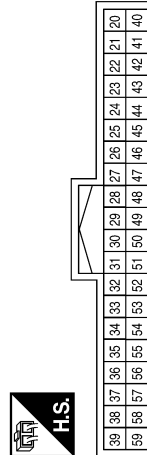

Terminal No.	Color of Wire	Signal Name
31	G	IGN F/B
38	GR/W	REAR DEFOGGER SW
59	G/R	REAR DEFOGGER RLY

Terminal No.	82G	Color of Wire	LG	Signal Name	-
--------------	-----	---------------	----	-------------	---

Connector No.	E30
Connector Name	WIRE TO WIRE
Connector Color	WHITE

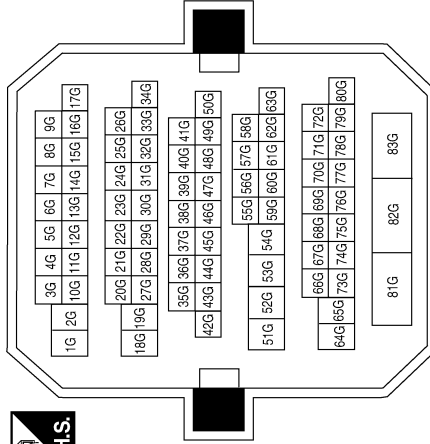

Connector No.	M37
Connector Name	FRONT AIR CONTROL (WITH AUTO A/C)
Connector Color	WHITE

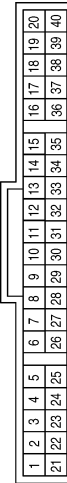

Terminal No.	Color of Wire	Signal Name
17	B	GND
22	GR	RR DEF F/B
23	GR/W	RR DEF ON
37	B	GND (POWER)
40	G	IGN

AALIA0448GB

REAR WINDOW DEFOGGER

< WIRING DIAGRAM >

Connector No.	B53
Connector Name	REAR WINDOW DEFOGGER
Connector Color	BLACK



Terminal No.	Color of Wire	Signal Name
1	B	-

Connector No.	B52
Connector Name	CONDENSER
Connector Color	WHITE



Terminal No.	Color of Wire	Signal Name
1	Y	-

Connector No.	B4
Connector Name	FUSE BLOCK (J/B)
Connector Color	BROWN

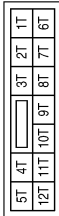

Terminal No.	Color of Wire	Signal Name
10T	Y	-
11T	Y	-

Connector No.	J-2
Connector Name	FUSE BLOCK (J/B) (REAR WINDOW DEFOGGER RELAY)
Connector Color	-

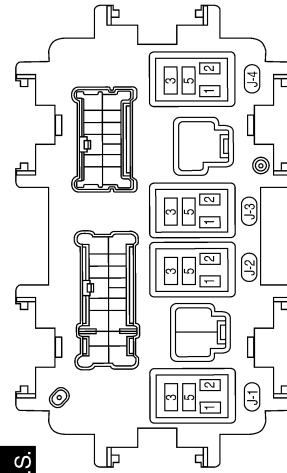

Connector No.	B54
Connector Name	REAR WINDOW DEFOGGER
Connector Color	BLACK



Terminal No.	Color of Wire	Signal Name
2	B	-

ABLIA2271GB

A
B
C
D
E
F
G
H
I
J
K
DEF
M
N
O
P

REAR WINDOW DEFOGGER DOES NOT OPERATE

< SYMPTOM DIAGNOSIS >

SYMPTOM DIAGNOSIS

REAR WINDOW DEFOGGER DOES NOT OPERATE

Diagnosis Procedure

INFOID:000000007422759

1. CHECK REAR WINDOW DEFOGGER SWITCH

Check rear window defogger switch.

Refer to [DEF-10, "Component Function Check"](#).

Is the inspection result normal?

YES >> GO TO 2

NO >> Repair or replace the malfunctioning parts.

2. CHECK REAR WINDOW DEFOGGER RELAY

Check rear window defogger relay.

Refer to [DEF-14, "Component Function Check"](#).

Is the inspection result normal?

YES >> GO TO 3

NO >> Repair or replace the malfunctioning parts.

3. CHECK REAR WINDOW DEFOGGER POWER SUPPLY AND GROUND CIRCUIT

Check rear window defogger power supply and ground circuit.

Refer to [DEF-16, "Component Function Check"](#).

Is the inspection result normal?

YES >> Check intermittent incident. Refer to [GI-42, "Intermittent Incident"](#).

NO >> Repair or replace the malfunctioning parts.

REAR WINDOW DEFOGGER SWITCH DOES NOT LIGHT, BUT REAR WINDOW DEFOGGER OPERATES

< SYMPTOM DIAGNOSIS >

REAR WINDOW DEFOGGER SWITCH DOES NOT LIGHT, BUT REAR WINDOW DEFOGGER OPERATES

Diagnosis Procedure

INFOID:000000007422760

1. CHECK FRONT AIR CONTROL (REAR WINDOW DEFOGGER SWITCH)

Check that the front air control (rear window defogger switch) is operating normally.

Is the inspection result normal?

- YES >> Check intermittent incident. Refer to [GI-42. "Intermittent Incident"](#).
- NO >> Refer to [DEF-10. "Diagnosis Procedure"](#).

A
B
C
D
E
F
G
H
I
J
K
DEF
M
N
O
P

PRECAUTIONS

< PRECAUTION >

PRECAUTION

PRECAUTIONS

Precaution for Supplemental Restraint System (SRS) "AIR BAG" and "SEAT BELT PRE-TENSIONER"

INFOID:000000007422761

The Supplemental Restraint System such as "AIR BAG" and "SEAT BELT PRE-TENSIONER", used along with a front seat belt, helps to reduce the risk or severity of injury to the driver and front passenger for certain types of collision. This system includes seat belt switch inputs and dual stage front air bag modules. The SRS system uses the seat belt switches to determine the front air bag deployment, and may only deploy one front air bag, depending on the severity of a collision and whether the front occupants are belted or unbelted. Information necessary to service the system safely is included in the SR and SB section of this Service Manual.

WARNING:

- To avoid rendering the SRS inoperative, which could increase the risk of personal injury or death in the event of a collision which would result in air bag inflation, all maintenance must be performed by an authorized NISSAN/INFINITI dealer.
- Improper maintenance, including incorrect removal and installation of the SRS, can lead to personal injury caused by unintentional activation of the system. For removal of Spiral Cable and Air Bag Module, see the SR section.
- Do not use electrical test equipment on any circuit related to the SRS unless instructed to in this Service Manual. SRS wiring harnesses can be identified by yellow and/or orange harnesses or harness connectors.

PRECAUTIONS WHEN USING POWER TOOLS (AIR OR ELECTRIC) AND HAMMERS

WARNING:

- When working near the Airbag Diagnosis Sensor Unit or other Airbag System sensors with the Ignition ON or engine running, DO NOT use air or electric power tools or strike near the sensor(s) with a hammer. Heavy vibration could activate the sensor(s) and deploy the air bag(s), possibly causing serious injury.
- When using air or electric power tools or hammers, always switch the Ignition OFF, disconnect the battery, and wait at least 3 minutes before performing any service.

Precaution Necessary for Steering Wheel Rotation After Battery Disconnect

INFOID:000000007422762

NOTE:

- Before removing and installing any control units, first turn the push-button ignition switch to the LOCK position, then disconnect both battery cables.
- After finishing work, confirm that all control unit connectors are connected properly, then re-connect both battery cables.
- Always use CONSULT to perform self-diagnosis as a part of each function inspection after finishing work. If a DTC is detected, perform trouble diagnosis according to self-diagnosis results.

This vehicle is equipped with a push-button ignition switch and a steering lock unit.

If the battery is disconnected or discharged, the steering wheel will lock and cannot be turned.

If turning the steering wheel is required with the battery disconnected or discharged, follow the procedure below before starting the repair operation.

OPERATION PROCEDURE

1. Connect both battery cables.

NOTE:

Supply power using jumper cables if battery is discharged.

2. Carry the Intelligent Key or insert it to the key slot and turn the push-button ignition switch to ACC position. (At this time, the steering lock will be released.)
3. Disconnect both battery cables. The steering lock will remain released with both battery cables disconnected and the steering wheel can be turned.
4. Perform the necessary repair operation.

PRECAUTIONS

< PRECAUTION >

5. When the repair work is completed, re-connect both battery cables. With the brake pedal released, turn the push-button ignition switch from ACC position to ON position, then to LOCK position. (The steering wheel will lock when the push-button ignition switch is turned to LOCK position.)
6. Perform self-diagnosis check of all control units using CONSULT.

Precaution for Work

INFOID:000000007422763

- When removing or disassembling each component, be careful not to damage or deform it. If a component may be subject to interference, be sure to protect it with a shop cloth.
- When removing (disengaging) components with a screwdriver or similar tool, be sure to wrap the component with a shop cloth or vinyl tape to protect it.
- Protect the removed parts with a shop cloth and prevent them from being dropped.
- Replace a deformed or damaged clip.
- If a part is specified as a non-reusable part, always replace it with new one.
- Be sure to tighten bolts and nuts securely to the specified torque.
- After installation is complete, be sure to check that each part works properly.
- Follow the steps below to clean components.
 - Water soluble dirt: Dip a soft cloth into lukewarm water, and wring the water out of the cloth to wipe the dirty area.
Then rub with a soft and dry cloth.
 - Oily dirt: Dip a soft cloth into lukewarm water with mild detergent (concentration: within 2 to 3%), and wipe the dirty area.
Then dip a cloth into fresh water, and wring the water out of the cloth to wipe the detergent off. Then rub with a soft and dry cloth.
- Do not use organic solvent such as thinner, benzene, alcohol, or gasoline.
- For genuine leather seats, use a genuine leather seat cleaner.

A
B
C
D
E
F
G
H
I
J
K

DEF

M
N
O
P

PREPARATION

< PREPARATION >

PREPARATION

PREPARATION

Special Service Tool

INFOID:000000007422764

The actual shapes of Kent-Moore tools may differ from those of special service tools illustrated here.

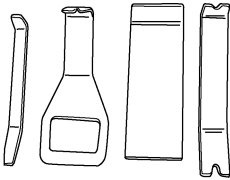
Tool number (Kent-Moore No.) Tool name	Description
— (J-46534) Trim Tool Set  AWJIA0483ZZ	Removing trim components

Commercial Service Tool

INFOID:000000007422765

Tool name	Description
Power tool  PIIB1407E	Loosening nuts, screws and bolts

FILAMENT

< REMOVAL AND INSTALLATION >

REMOVAL AND INSTALLATION

FILAMENT

Inspection and Repair

INFOID:000000007422766

INSPECTION

1. When measuring voltage, wrap tin foil around the top of the negative probe. Then press the foil against the wire with your finger.

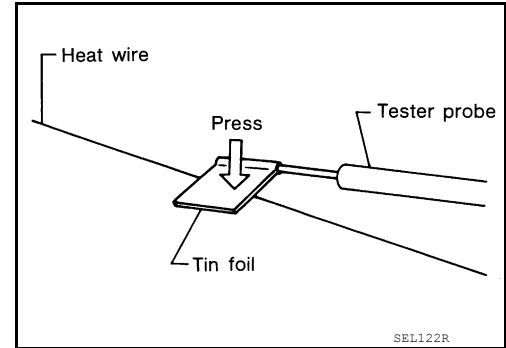

2. Attach probe circuit tester (in Volt range) to middle portion of each filament.

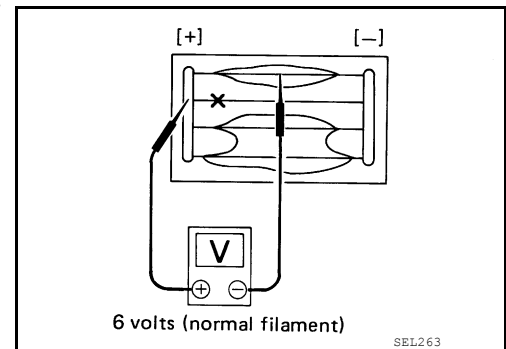

3. If a filament is burned out, circuit tester registers 0 or battery voltage.
4. To locate burned out point, move probe to left and right along filament. Test needle will swing abruptly when probe passes the point.

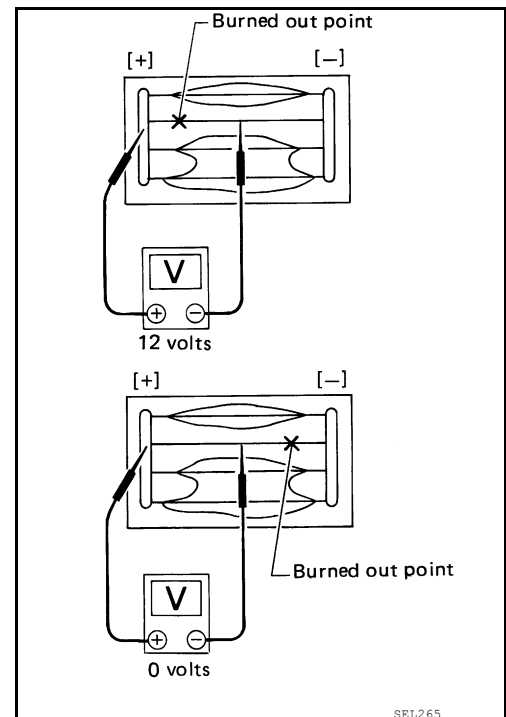

REPAIR

REPAIR EQUIPMENT

- Conductive silver composition (Dupont No. 4817 or equivalent)

A
B
C
D
E
F
G
H
I
J
K
DEF
M
N
O
P

FILAMENT

< REMOVAL AND INSTALLATION >

- Ruler 30 cm (11.8 in) long
- Drawing pen
- Heat gun
- Alcohol
- Cloth

REPAIRING PROCEDURE

1. Wipe broken heat wire and its surrounding area clean with a cloth dampened in alcohol.
2. Apply a small amount of conductive silver composition to tip of drawing pen. Shake silver composition container before use.
3. Place ruler on glass along broken line. Deposit conductive silver composition on break with drawing pen. Slightly overlap existing heat wire on both sides [preferably 5 mm (0.20 in)] of the break.

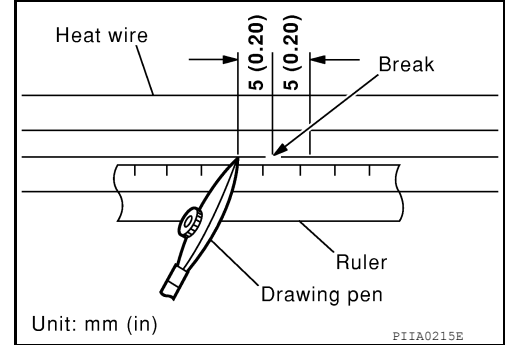

4. After repair has been completed, check repaired wire for continuity. This check should be conducted 10 minutes after silver composition is deposited. Do not touch repaired area while test is being conducted.

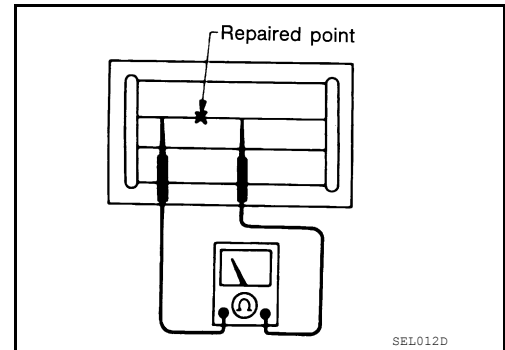

5. Apply a constant stream of hot air directly to the repaired area for approximately 20 minutes with a heat gun. A minimum distance of 3 cm (1.2 in) should be kept between repaired area and hot air outlet. If a heat gun is not available, let the repaired area dry for 24 hours.

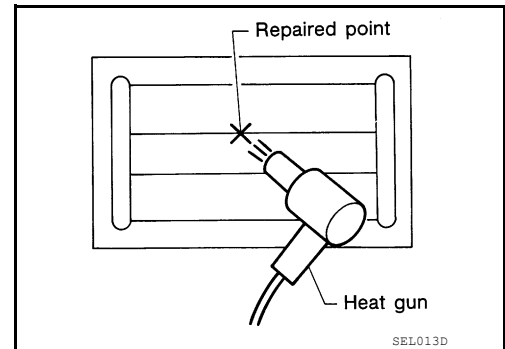

CONDENSER

< REMOVAL AND INSTALLATION >

CONDENSER

Removal and Installation - Coupe

INFOID:000000007422767

REMOVAL

1. Remove the rear seat cushion and rear seatback. Refer to [SE-23, "Removal and Installation"](#).
2. Remove the following trim components. Refer to [INT-44, "Removal and Installation"](#).
 - rear kick plate
 - rear lower finisher
 - upper pillar finisher
 - rear pillar finisher
3. Disconnect the condenser electrical connectors (A).
4. Remove bolt (B) and the condenser (1) from the vehicle body.

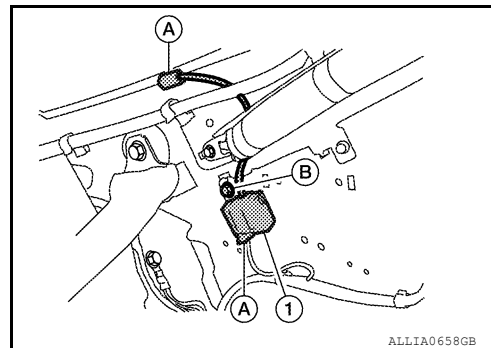

INSTALLATION

Installation is in the reverse order of removal.

Removal and Installation - Sedan

INFOID:000000007422768

REMOVAL

1. Remove the rear pillar finisher. Refer to [INT-18, "Removal and Installation"](#).
2. Disconnect the condenser electrical connector.
3. Remove the bolt (A) and the condenser (1) from the vehicle body.

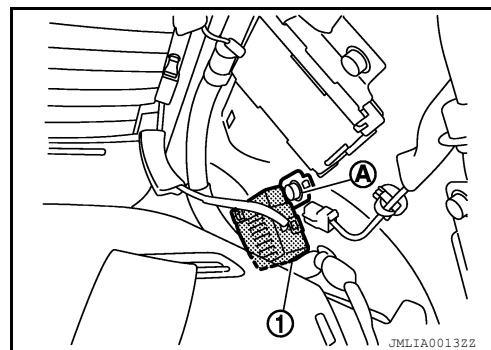

INSTALLATION

Installation is in the reverse order of removal.

A
B
C
D
E
F
G
H
I
J
K
DEF
M
N
O
P