

A  
CO  
C  
D  
E  
F  
G  
H  
I  
J  
K  
L  
M  
N  
O  
P

# SECTION **CO**

## ENGINE COOLING SYSTEM

### CONTENTS

<b>QR25DE</b>	
<b>PRECAUTION</b> .....	3
<b>PRECAUTIONS</b> .....	3
Precaution for Supplemental Restraint System (SRS) "AIR BAG" and "SEAT BELT PRE-TENSIONER" .....	3
Precaution for Liquid Gasket .....	3
<b>PREPARATION</b> .....	5
<b>PREPARATION</b> .....	5
Special Service Tool .....	5
Commercial Service Tool .....	5
<b>SYSTEM DESCRIPTION</b> .....	7
<b>COOLING SYSTEM</b> .....	7
Cooling Circuit .....	7
Schematic .....	8
<b>OVERHEATING CAUSE ANALYSIS</b> .....	9
Troubleshooting Chart .....	9
<b>PERIODIC MAINTENANCE</b> .....	11
<b>ENGINE COOLANT</b> .....	11
System Inspection .....	11
Changing Engine Coolant .....	12
<b>REMOVAL AND INSTALLATION</b> .....	16
<b>RADIATOR</b> .....	16
Exploded View .....	16
Removal and Installation .....	17
Inspection .....	17
<b>COOLING FAN</b> .....	18
Exploded View .....	18
Removal and Installation .....	18
<b>WATER PUMP</b> .....	20
Exploded View .....	20
Removal and Installation .....	20
<b>THERMOSTAT AND THERMOSTAT HOUSING</b> .....	22
Exploded View .....	22
Removal and Installation .....	22
<b>WATER OUTLET AND WATER PIPING</b> .....	24
Exploded View .....	24
Removal and Installation .....	24
<b>SERVICE DATA AND SPECIFICATIONS (SDS)</b> .....	26
<b>SERVICE DATA AND SPECIFICATIONS (SDS)</b> .....	26
Capacity .....	26
Thermostat .....	26
Radiator .....	26
<b>VQ35DE</b>	
<b>PRECAUTION</b> .....	27
<b>PRECAUTIONS</b> .....	27
Precaution for Supplemental Restraint System (SRS) "AIR BAG" and "SEAT BELT PRE-TENSIONER" .....	27
Precaution for Liquid Gasket .....	27
<b>PREPARATION</b> .....	29
<b>PREPARATION</b> .....	29
Special Service Tool .....	29
Commercial Service Tool .....	29
<b>SYSTEM DESCRIPTION</b> .....	31
<b>COOLING SYSTEM</b> .....	31
Cooling Circuit .....	31
Schematic .....	32

<b>OVERHEATING CAUSE ANALYSIS</b> .....	<b>33</b>	Exploded View .....	44
Troubleshooting Chart .....	33	Removal and Installation .....	44
<b>PERIODIC MAINTENANCE</b> .....	<b>35</b>	<b>THERMOSTAT AND THERMOSTAT HOUS-</b>	
<b>ENGINE COOLANT</b> .....	<b>35</b>	<b>ING</b> .....	<b>49</b>
System Inspection .....	35	Exploded View .....	49
Changing Engine Coolant .....	36	Removal and Installation .....	49
<b>REMOVAL AND INSTALLATION</b> .....	<b>40</b>	<b>WATER OUTLET AND WATER PIPING</b> .....	<b>51</b>
<b>RADIATOR</b> .....	<b>40</b>	Exploded View .....	51
Exploded View .....	40	Removal and Installation .....	51
Removal and Installation .....	41	<b>SERVICE DATA AND SPECIFICATIONS</b>	
Inspection .....	41	<b>(SDS)</b> .....	<b>53</b>
<b>COOLING FAN</b> .....	<b>42</b>	<b>SERVICE DATA AND SPECIFICATIONS</b>	
Exploded View .....	42	<b>(SDS)</b> .....	<b>53</b>
Removal and Installation .....	42	Capacity .....	53
<b>WATER PUMP</b> .....	<b>44</b>	Thermostat .....	53
		Radiator .....	53

PRECAUTION

PRECAUTIONS

Precaution for Supplemental Restraint System (SRS) "AIR BAG" and "SEAT BELT PRE-TENSIONER"

INFOID:000000009951689

The Supplemental Restraint System such as "AIR BAG" and "SEAT BELT PRE-TENSIONER", used along with a front seat belt, helps to reduce the risk or severity of injury to the driver and front passenger for certain types of collision. Information necessary to service the system safely is included in the SR and SB section of this Service Manual.

**WARNING:**

- To avoid rendering the SRS inoperative, which could increase the risk of personal injury or death in the event of a collision which would result in air bag inflation, all maintenance must be performed by an authorized NISSAN/INFINITI dealer.
- Improper maintenance, including incorrect removal and installation of the SRS, can lead to personal injury caused by unintentional activation of the system. For removal of Spiral Cable and Air Bag Module, see the SR section.
- Do not use electrical test equipment on any circuit related to the SRS unless instructed to in this Service Manual. SRS wiring harnesses can be identified by yellow and/or orange harnesses or harness connectors.

PRECAUTIONS WHEN USING POWER TOOLS (AIR OR ELECTRIC) AND HAMMERS

**WARNING:**

- When working near the Airbag Diagnosis Sensor Unit or other Airbag System sensors with the Ignition ON or engine running, DO NOT use air or electric power tools or strike near the sensor(s) with a hammer. Heavy vibration could activate the sensor(s) and deploy the air bag(s), possibly causing serious injury.
- When using air or electric power tools or hammers, always switch the Ignition OFF, disconnect the battery and wait at least three minutes before performing any service.

Precaution for Liquid Gasket

INFOID:000000009460384

REMOVAL OF LIQUID GASKET

- After removing the bolts and nuts, separate the mating surface and remove the liquid gasket using Tool (A).

Tool Number (A): KV10111100 (J-37228)

**CAUTION:**

Be careful not to damage the mating surfaces.

- In areas where the cutter is difficult to use, use a plastic hammer to lightly tap (1) the cutter where the liquid gasket is applied. Use a plastic hammer to slide (2) the cutter by tapping on the side.

**CAUTION:**

Do not damage the mating surfaces.

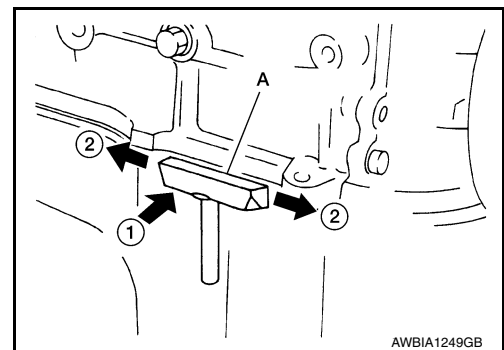

AWBIA1249GB

LIQUID GASKET APPLICATION PROCEDURE

1. Using a scraper, remove the old liquid gasket adhering to the gasket application surface and the mating surface.
  - Remove the liquid gasket completely from the groove of the gasket application surface, mounting bolts, and bolt holes.
2. Thoroughly clean the gasket application surface and the mating surface and remove adhering moisture, grease and foreign materials.
3. Attach the liquid gasket tube to the tube presser. Use Genuine Silicone RTV Sealant or equivalent. Refer to [GI-21, "Recommended Chemical Products and Sealants"](#).

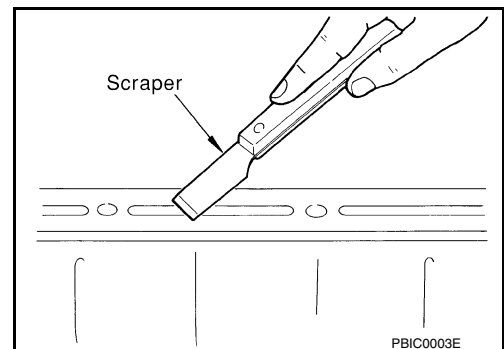

PBIC0003E

A  
CO  
C  
D  
E  
F  
G  
H  
I  
J  
K  
L  
M  
N  
O  
P

# PRECAUTIONS

[QR25DE]

## < PRECAUTION >

4. Apply the liquid gasket using suitable tool without breaks to the specified location.
  - If there is a groove for the liquid gasket application, apply the liquid gasket to the groove.
  - As for the bolt holes, normally apply the liquid gasket inside the holes. If specified, it should be applied outside the holes. Make sure to read the text of this manual.
  - Within five minutes of the liquid gasket application, install the mating component.
  - If the liquid gasket protrudes, wipe it off immediately.
  - Do not retighten after the installation.

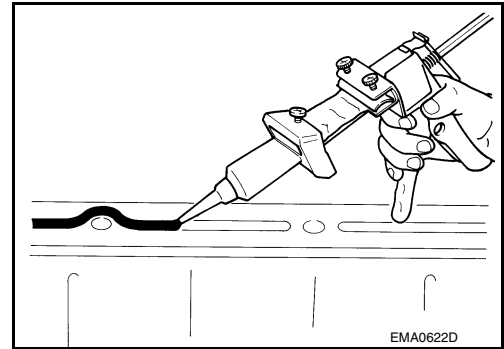

- After 30 minutes or more have passed from the installation, fill the engine with the specified oil and coolant. Refer to [MA-11](#), "[FOR USA AND CANADA : Fluids and Lubricants](#)".

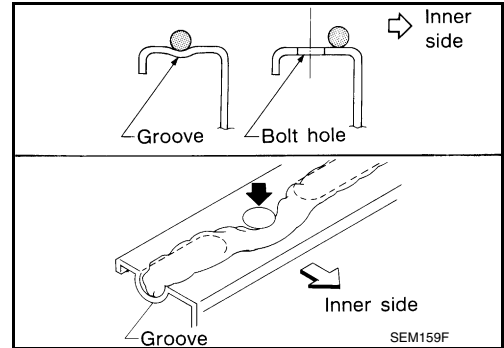

### CAUTION:

If there are more specific instructions in the procedures contained in this manual concerning liquid gasket application, observe them.

# PREPARATION

< PREPARATION >

[QR25DE]

## PREPARATION

### PREPARATION

#### Special Service Tool

INFOID:000000009460385

A

CO

The actual shapes of the tools may differ from those illustrated here.

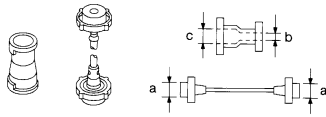
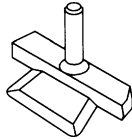
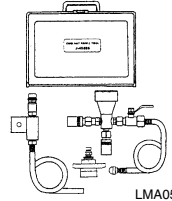
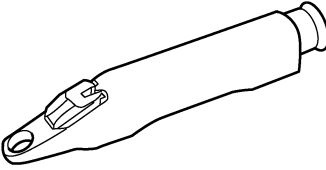
Tool number (TechMate No.) Tool name	Description
EG17650301 (J-33984-A) Radiator cap tester adapter <div style="text-align: center;">  <p>S-NT564</p> </div>	Adapting radiator cap tester to radiator cap and radiator filler neck <b>a: 28 (1.10) dia.</b> <b>b: 31.4 (1.236) dia.</b> <b>c: 41.3 (1.626) dia.</b> Unit: mm (in)
KV10111100 (J-37228) Seal cutter <div style="text-align: center;">  <p>NT046</p> </div>	Removing chain tensioner cover and water pump cover
KV991J0070 (J-45695) Coolant Refill Tool <div style="text-align: center;">  <p>LMA053</p> </div>	Refilling engine cooling system
— (J-23688) Engine coolant refractometer <div style="text-align: center;">  <p>WBIA0539E</p> </div>	Checking concentration of ethylene glycol in engine coolant

C

D

E

F

G

H

I

J

K

L

M

#### Commercial Service Tool

INFOID:000000009460386

N

O

P

# PREPARATION

< PREPARATION >

[QR25DE]

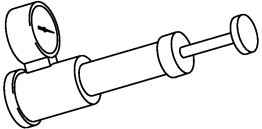
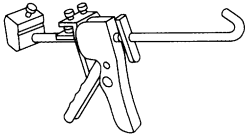
Tool name	Description
<p data-bbox="159 197 272 222">Power tool</p>  <p data-bbox="829 415 894 432">PIB1407E</p>	<p data-bbox="1013 197 1344 222">Loosening nuts, screws and bolts</p>
<p data-bbox="159 449 354 474">Radiator cap tester</p>  <p data-bbox="829 663 894 680">PBIC1982E</p>	<p data-bbox="1013 449 1208 474">Testing radiator cap</p>
<p data-bbox="159 701 298 726">Tube presser</p>  <p data-bbox="829 915 886 932">S-NT052</p>	<p data-bbox="1013 701 1344 726">Pressing the tube of liquid gasket</p>

# COOLING SYSTEM

< SYSTEM DESCRIPTION >

[QR25DE]

## SYSTEM DESCRIPTION

### COOLING SYSTEM

#### Cooling Circuit

INFOID:000000009460387

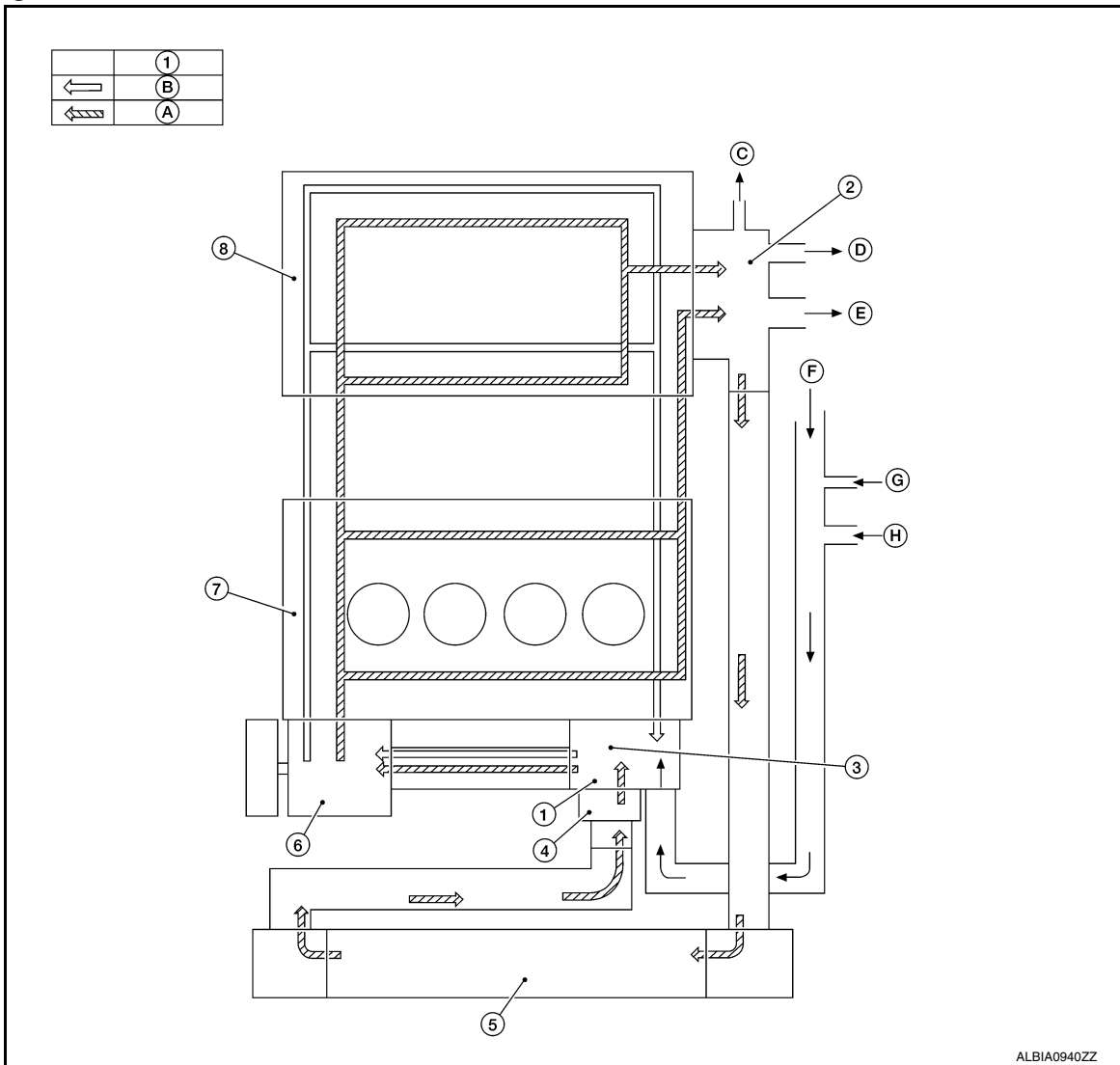

- |                    |  |  |
|--------------------|--|--|
| 1. Thermostat      | 2. Water outlet                          | 3. Cylinder block (Thermostat housing)     |
| 4. Water inlet     | 5. Radiator                              | 6. Water pump                              |
| 7. Cylinder block  | 8. Cylinder head                         | A. Open                                    |
| B. Closed          | C. To electric throttle control actuator | D. To oil cooler                           |
| E. To heater       | F. From heater                           | G. From electric throttle control actuator |
| H. From oil cooler |  |  |

# COOLING SYSTEM

< SYSTEM DESCRIPTION >

[QR25DE]

## Schematic

INFOID:000000009460388

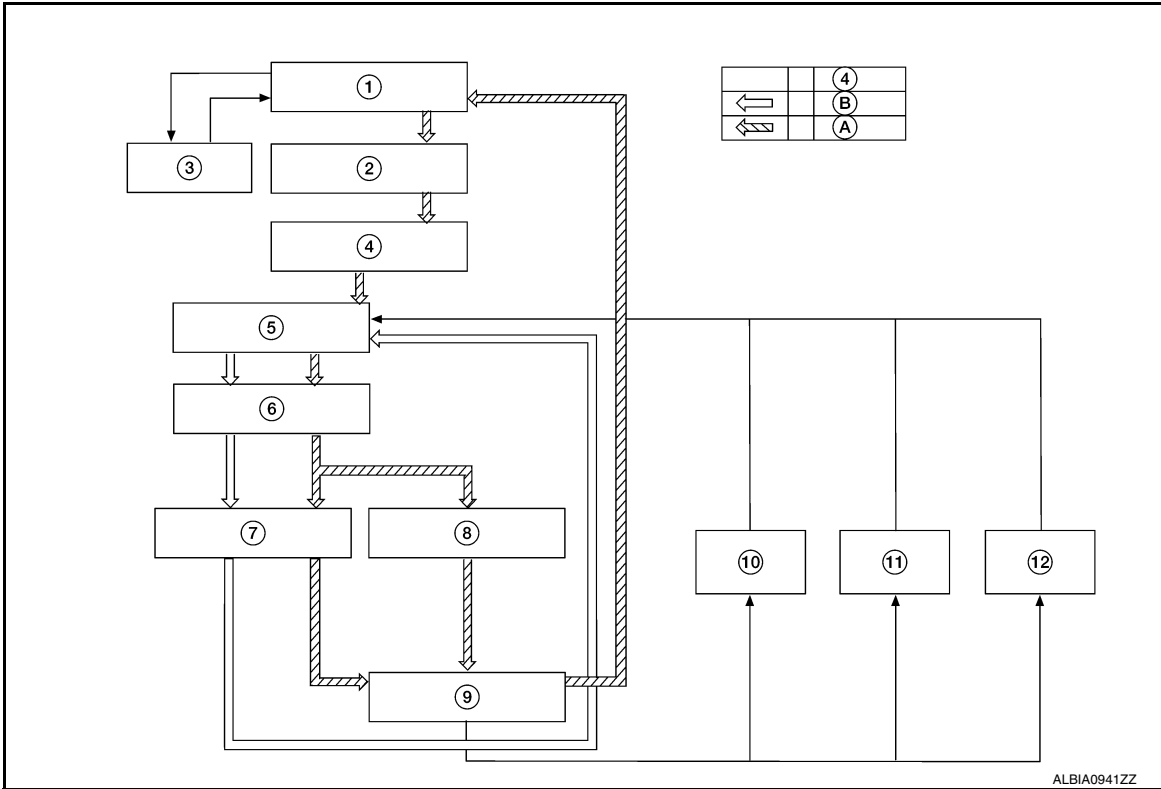

- |                  |                       |  |
|------------------|-----------------------|--|
| 1. Radiator      | 2. Water inlet        | 3. Reservoir tank                      |
| 4. Thermostat    | 5. Thermostat housing | 6. Water pump                          |
| 7. Cylinder head | 8. Cylinder block     | 9. Water outlet                        |
| 10. Heater       | 11. Oil cooler        | 12. Electric throttle control actuator |
| A. Open          | B. Closed             |  |



# OVERHEATING CAUSE ANALYSIS

< SYSTEM DESCRIPTION >

[QR25DE]

## OVERHEATING CAUSE ANALYSIS

### Troubleshooting Chart

INFOID:000000009460389

		Symptom	Check items		
Cooling system parts malfunction	Poor heat transfer	Water pump malfunction	Worn or loose drive belt	—	
		Thermostat stuck closed	Coolant circulation		
		Damaged fins	Dust contamination or rock clogging		
			Mechanical damage		
		Clogged radiator cooling tube	Excess foreign material (rust, dirt, sand, etc.)		
	Reduced air flow	Cooling fan does not operate	Engine cooling fans	—	
		High resistance to fan rotation			
		Damaged fan blades			
		Damaged radiator shroud	—	Radiator shroud	—
		Improper coolant mixture ratio	—	Coolant viscosity	—
		Poor coolant quality	—	Periodic maintenance	—
	Insufficient coolant	Coolant leaks	Cooling hose	Loose clamp	
				Cracked hose	
			Water pump	Poor sealing	
			Radiator cap	Loose	
Poor sealing					
Radiator			O-ring for damage, deterioration or improper fitting		
		Cracked radiator tank			
		Cracked radiator core			
	Reservoir tank	Cracked reservoir tank			
Overflowing reservoir tank	Exhaust gas leaks into cooling system	Cylinder head deterioration			
		Cylinder head gasket deterioration			

A  
CO  
C  
D  
E  
F  
G  
H  
I  
J  
K  
L  
M  
N  
O  
P

# OVERHEATING CAUSE ANALYSIS

< SYSTEM DESCRIPTION >

[QR25DE]

	Symptom		Check items		
Except cooling system parts malfunction	—	Overload on engine	Abusive driving	High engine rpm under no load	
				Driving in low gear for extended time	
				Driving at extremely high speed	
			Powertrain system malfunction	—	
			Installed improper size wheels and tires		
			Dragging brakes		
	Blocked or restricted air flow	Blocked radiator grille	Blocked radiator grille	Installed car brassiere	—
				Blocked bumper	
				Blocked radiator	
				Blocked condenser	
Installed large fog lamp					
			Mud contamination or paper clogging		

# PERIODIC MAINTENANCE

## ENGINE COOLANT

### System Inspection

INFOID:000000009460390

#### **WARNING:**

Do not remove the radiator cap when the engine is hot. Serious burns could occur from high-pressure engine coolant escaping from the radiator. Wrap a thick cloth around the cap. Slowly push down and turn it a quarter turn to allow built-up pressure to escape. Carefully remove the cap by pushing it down and turning it all the way.

#### CHECKING COOLING SYSTEM HOSES

Check hoses for the following:

- Improper attachment
- Leaks
- Cracks
- Damage
- Loose connections
- Chafing
- Deterioration

#### CHECKING RESERVOIR LEVEL

- Check if the reservoir tank coolant level is within MIN to MAX when the engine is cool.
- Adjust coolant level if it is too much or too little.

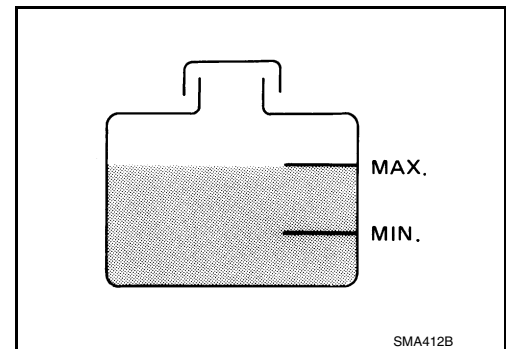

#### CHECKING COOLING SYSTEM FOR LEAKS

To check for leakage, apply pressure to the cooling system using suitable tool (A) and Tool (B).

**Tool number** : EG17650301 (J-33984-A)

**Testing pressure** : Refer to [CO-26, "Radiator"](#).

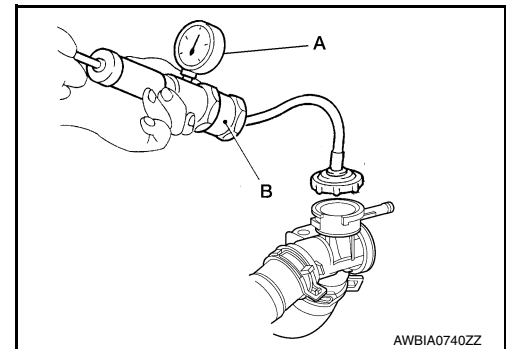

#### **WARNING:**

Do not remove the radiator cap when the engine is hot. Serious burns could occur from high pressure coolant escaping from the radiator.

#### **CAUTION:**

Higher pressure than specified may cause radiator damage.

#### CHECKING RADIATOR CAP

1. Inspect the radiator cap.
  - Replace the cap if the metal plunger cannot be seen around the edge of the black rubber gasket.
  - Replace the cap if deposits of waxy residue or other foreign material are on the black rubber gasket or the metal retainer.

#### **NOTE:**

Thoroughly wipe out the radiator filler neck to remove any waxy residue or foreign material.

# ENGINE COOLANT

[QR25DE]

## < PERIODIC MAINTENANCE >

2. Pull the negative-pressure valve to open it and check that it closes completely when released.
  - Check that there is no dirt or damage on the valve seat of the radiator cap negative-pressure valve.
  - Check that there are no abnormalities in the opening and closing conditions of the negative-pressure valve.

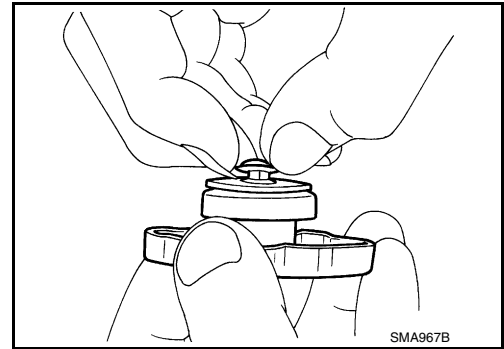

3. Check radiator cap relief pressure using suitable tool and Tool.

**Tool number** : EG17650301 (J-33984-A)

**Standard:** Refer to [CO-26, "Radiator"](#).

- When connecting the radiator cap to the tester, apply water or coolant to the cap seal surface.
- Replace the radiator cap if there is an abnormality in the negative-pressure valve, or if the open-valve pressure is outside of the standard values.

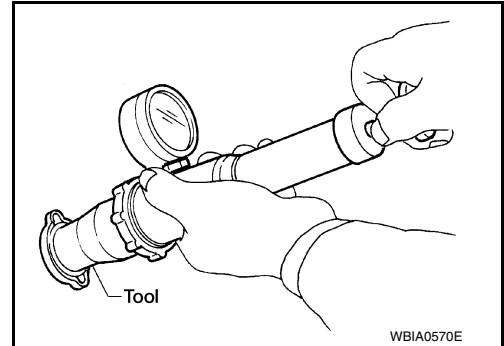

## CHECKING RADIATOR

Check radiator for mud or clogging. If necessary, clean radiator as follows.

### CAUTION:

- **Be careful not to bend or damage the radiator fins.**
- **When radiator is cleaned on-vehicle, remove surrounding parts in order to access the radiator core. Tape the harness and electrical connectors to prevent water from entering.**

1. Spray water to the back side of the radiator core using a side to side motion from the top down.
2. Stop spraying when debris no longer flows from radiator core.
3. Blow air into the back side of radiator core using a side to side motion from the top down.
  - Use compressed air lower than 490 kPa (5 kg/cm<sup>2</sup>, 71 psi) and keep distance more than 30 cm (11.8 in).
4. Continue to blow air until no water sprays out.
5. Check for coolant leaks. Repair as necessary.

## Changing Engine Coolant

INFOID:000000009460391

### WARNING:

**Do not remove the radiator cap when the engine is hot. Serious burns could occur from high-pressure engine coolant escaping from the radiator. Wrap a thick cloth around the cap. Slowly push down and turn it a quarter turn to allow built-up pressure to escape. Carefully remove the cap by pushing it down and turning it all the way.**

## DRAINING ENGINE COOLANT

1. Remove the engine under cover. Refer to [EXT-17, "Removal and Installation"](#).
2. Open the radiator drain plug at the bottom of the radiator and remove the radiator filler cap. This is the only step required when partially draining the cooling system (radiator only).

### CAUTION:

- **Do not allow the coolant to contact the drive belt.**
  - **Perform this step when engine is cold.**
3. Follow this step for heater core removal/replacement only. Disconnect the upper heater hose at the engine side and apply moderate air pressure [103.46 kPa (1.055 kg/cm<sup>2</sup>, 15 psi) maximum air pressure] into the hose for 30 seconds to blow the excess coolant out of the heater core.
  4. When draining all of the coolant in the system, remove the reservoir tank and drain the coolant, then clean the reservoir tank before installation.

# ENGINE COOLANT

[QR25DE]

< PERIODIC MAINTENANCE >

## CAUTION:

- Do not allow the coolant to contact the drive belt.
- Perform this step when engine is cold.

5. When draining all of the coolant in the system for engine removal or repair, open the drain plugs (A and B) on the cylinder block.

⇐: Front

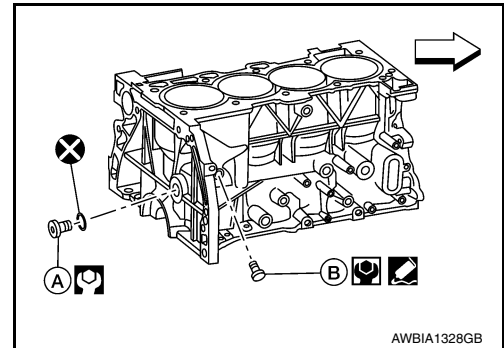

6. Check the drained coolant for contaminants such as rust, corrosion or discoloration. If the coolant is contaminated, flush the engine cooling system.

## REFILLING ENGINE COOLANT

1. Install the radiator drain plug. Install the reservoir tank and cylinder block drain plug, if removed for a total system drain or for engine removal or repair.

- The radiator must be completely empty of coolant and water.
- Apply sealant to the threads of the cylinder block drain plug. Use Genuine High Performance Thread Sealant or equivalent. Refer to [GI-21, "Recommended Chemical Products and Sealants"](#).

⇐: Front

## CAUTION:

Do not reuse copper sealing washers.

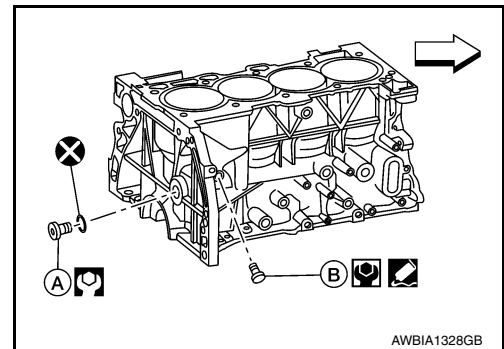

- |                               |   |
|-------------------------------|---|
| Radiator drain plug           | : Refer to <a href="#">CO-16, "Exploded View"</a> . |
| Cylinder block drain plug (A) | : 54 Nm (5.5 kg-m, 40 ft-lb)                        |
| Cylinder block drain plug (B) | : 9.8 N·m (1.0 kg-m, 87 in-lb)                      |

2. If disconnected, reattach the upper radiator hose at the engine side.
3. Set the vehicle heater controls to the full HOT and heater ON position. Turn the vehicle ignition ON with the engine OFF as necessary to activate the heater mode.

# ENGINE COOLANT

[QR25DE]

## < PERIODIC MAINTENANCE >

4. Install the Tool by installing the radiator cap adapter onto the radiator neck opening. Then attach the gauge body assembly with the refill tube and the venturi assembly to the radiator cap adapter.

**Tool number** : KV991J0070 (J-45695)

5. Insert the refill hose into the coolant mixture container that is placed at floor level. Make sure the ball valve is in the closed position.

- Use recommended coolant or equivalent.

Refer to [MA-11, "FOR USA AND CANADA : Fluids and Lubricants"](#).

**Engine coolant capacity** : Refer to [CO-26, "Capacity"](#).  
(with reservoir tank)

### CAUTION:

Do not use any cooling system additives such as radiator sealer. Additives may clog the cooling system and cause damage to the engine, transmission and/or cooling system.

6. Install an air hose to the venturi assembly, the air pressure must be within specification.

**Compressed air supply pressure** : 549 - 824 kPa (5.6 - 8.4 kg/cm<sup>2</sup>,  
80 - 119 psi)

### CAUTION:

The compressed air supply must be equipped with an air dryer.

7. The vacuum gauge will begin to rise and there will be an audible hissing noise. During this process open the ball valve on the refill hose slightly. Coolant will be visible rising in the refill hose. Once the refill hose is full of coolant, close the ball valve. This will purge any air trapped in the refill hose.

8. Continue to draw the vacuum until the gauge reaches 28 inches of vacuum. The gauge may not reach 28 inches in high altitude locations, use the vacuum specifications based on the altitude above sea level.

Altitude above sea level	Vacuum gauge reading
0 - 100 m (328 ft)	: 28 inches of vacuum
300 m (984 ft)	: 27 inches of vacuum
500 m (1,641 ft)	: 26 inches of vacuum
1,000 m (3,281 ft)	: 24 - 25 inches of vacuum

9. When the vacuum gauge has reached the specified amount, disconnect the air hose and wait 20 seconds to see if the system loses any vacuum. If the vacuum level drops, perform any necessary repairs to the system and repeat steps 6 - 8 to bring the vacuum to the specified amount. Recheck for any leaks.

10. Place the coolant container (with the refill hose inserted) at the same level as the top of the radiator. Then open the ball valve on the refill hose so the coolant will be drawn up to fill the cooling system. The cooling system is full when the vacuum gauge reads zero.

### CAUTION:

Do not allow the coolant container to get too low when filling, to avoid air from being drawn into the cooling system.

11. Remove the Tool from the radiator neck opening.
12. Fill the cooling system reservoir tank to the specified level and install the radiator cap. Run the engine to warm up the cooling system and top up the system as necessary.
13. Install the engine under cover. Refer to [EXT-17, "Removal and Installation"](#).

## FLUSHING COOLING SYSTEM

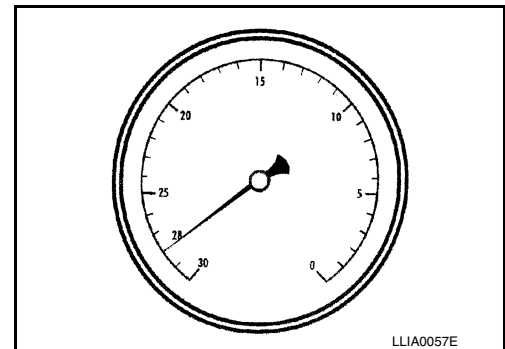
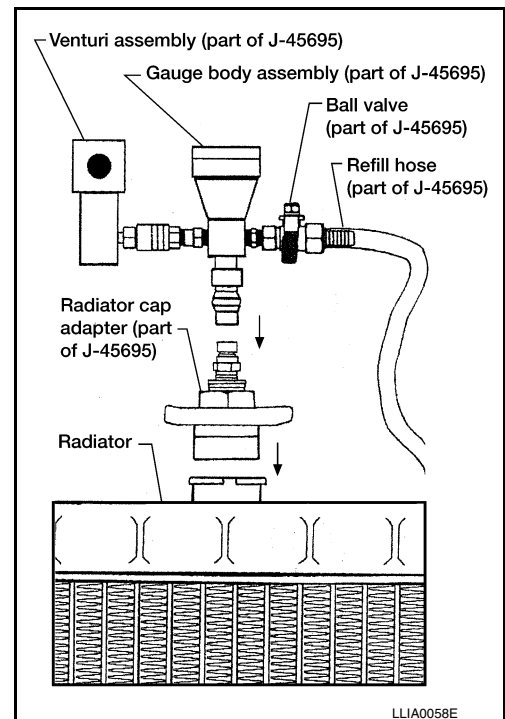

## ENGINE COOLANT

[QR25DE]

< PERIODIC MAINTENANCE >

1. Fill the radiator from the filler neck above the radiator upper hose and reservoir tank with clean water and reinstall the radiator filler cap.
2. Run the engine until it reaches normal operating temperature.
3. Rev the engine two or three times under no-load.
4. Stop the engine and wait until it cools down.
5. Drain the water from the system. Refer to [CO-12. "Changing Engine Coolant"](#).
6. Repeat steps 1 through 5 until clear water begins to drain from the radiator.

A

CO

C

D

E

F

G

H

I

J

K

L

M

N

O

P

# RADIATOR

< REMOVAL AND INSTALLATION >

[QR25DE]

## REMOVAL AND INSTALLATION

### RADIATOR

Exploded View

INFOID:000000009460392

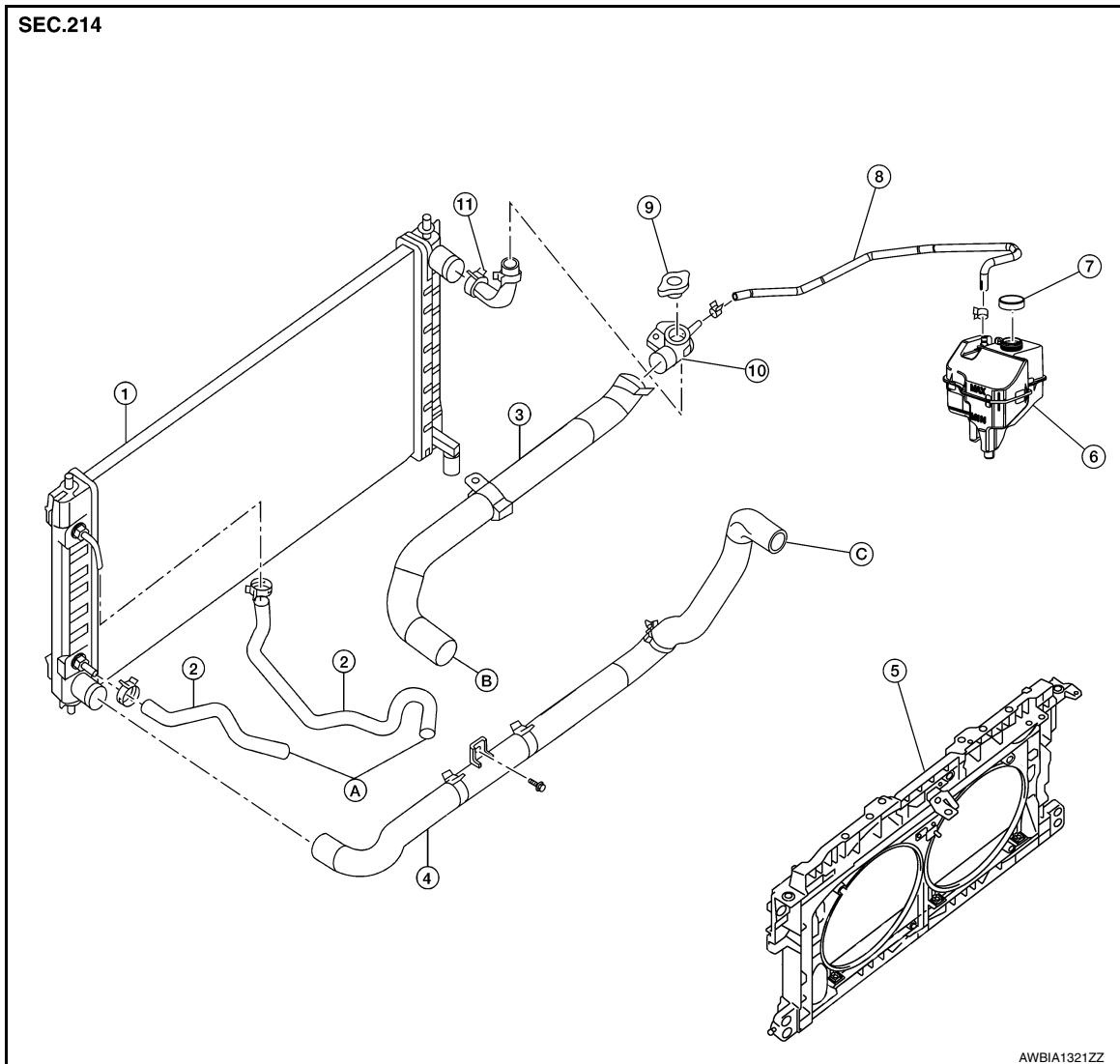

- |                          |                          |                          |
|--------------------------|--------------------------|--------------------------|
| 1. Radiator              | 2. CVT oil cooler hose   | 3. Radiator hose (upper) |
| 4. Radiator hose (lower) | 5. Radiator core support | 6. Reservoir tank        |
| 7. Reservoir tank cap    | 8. Reservoir tank hose   | 9. Radiator filler cap   |
| 10. Filler neck          | 11. Filler neck hose     | A. To CVT                |
| B. To water outlet       | C. To water inlet        |                          |

#### **WARNING:**

Do not remove the radiator cap when the engine is hot. Serious burns could occur from high-pressure engine coolant escaping from the radiator. Wrap a thick cloth around the cap. Slowly push down and turn it a quarter turn to allow built-up pressure to escape. Carefully remove the cap by pushing it down and turning it all the way.

#### **NOTE:**

When removing components such as hoses, tubes/lines, etc., cap or plug openings to prevent fluid from spilling.



# RADIATOR

< REMOVAL AND INSTALLATION >

[QR25DE]

## Removal and Installation

INFOID:000000009460393

### REMOVAL

1. Remove radiator cap and drain coolant from radiator. Refer to [CO-12, "Changing Engine Coolant"](#).  
**CAUTION:**
  - Perform this step when the engine is cold.
  - Do not spill coolant on the drive belt.
2. Remove front air duct. Refer to [EM-84, "Removal and Installation"](#).
3. Disconnect coolant reservoir hose from the radiator.
4. Remove fender protector side cover (LH/RH). Refer to [EXT-26, "FENDER PROTECTOR : Exploded View"](#).
5. Disconnect radiator hose (upper) and radiator hose (lower) from the radiator.  
**CAUTION:**  
**Do not allow the coolant to contact the drive belt.**  
**NOTE:**  
The radiator hose clamps on the radiator hose (upper) and on the radiator hose (lower), are not serviced separately. Radiator hose clamps are part of the radiator hose assembly and serviced as one unit with the radiator hose.
6. Disconnect the CVT oil cooler hoses.
7. Remove the front bumper fascia. Refer to [EXT-17, "Removal and Installation"](#).
8. Remove A/C condenser. Refer to [HA-30, "COMPRESSOR : Removal and Installation"](#).  
**CAUTION:**  
**Be careful not to damage condenser core.**
9. Remove the radiator mounts (upper).
10. Remove radiator.  
**CAUTION:**  
**Do not damage or scratch the radiator core when removing.**

### INSTALLATION

Installation is in the reverse order of removal.

- After installation, refill coolant and check for leaks. Refer to [CO-12, "Changing Engine Coolant"](#) and [CO-11, "System Inspection"](#).

#### **CAUTION:**

**Do not spill coolant in engine compartment. Use a shop cloth to absorb coolant.**

### Inspection

INFOID:000000009460394

### INSPECTION AFTER INSTALLATION

- Check that the reservoir tank cap is tightened.
- Check for leakage of engine coolant using Tool (B) and suitable tool (A). Refer to [CO-11, "System Inspection"](#).

**Tool number** : EG17650301 (J-33984-A)

**Testing pressure** : Refer to [CO-26, "Radiator"](#).

#### **WARNING:**

**Do not remove the radiator cap when the engine is hot. Serious burns could occur from high pressure coolant escaping from the radiator.**

#### **CAUTION:**

**Higher pressure than specified may cause radiator damage.**

- Start and warm up the engine. Visually check that there is no leakage of engine coolant and CVT fluid.

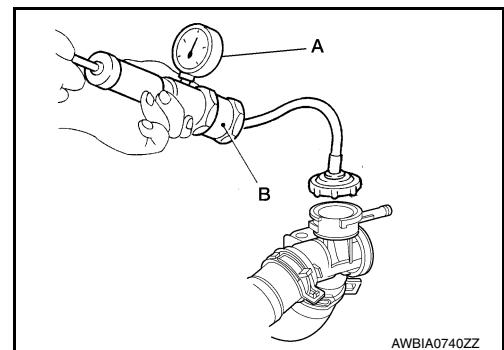

# COOLING FAN

< REMOVAL AND INSTALLATION >

[QR25DE]

## COOLING FAN

### Exploded View

INFOID:000000009460395

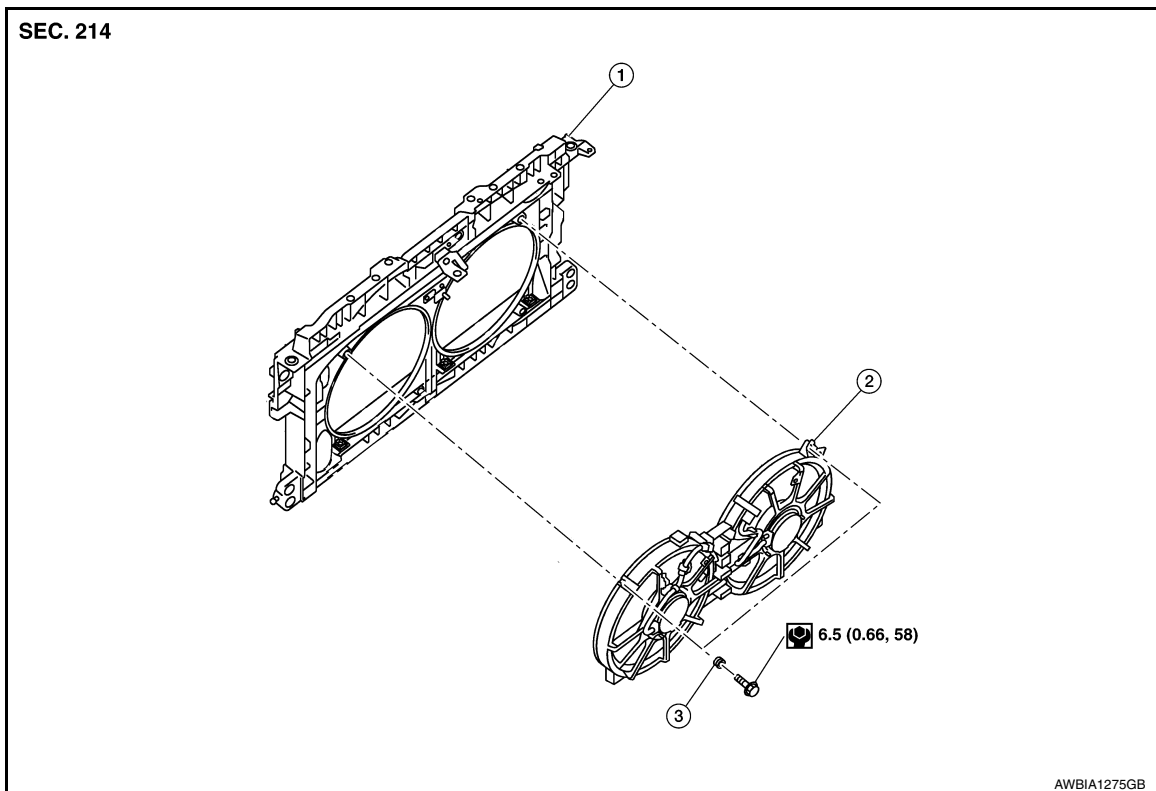

1. Radiator core support

2. Fan shroud and motor assembly

3. Grommet

#### **WARNING:**

Do not remove the radiator cap when the engine is hot. Serious burns could occur from high-pressure engine coolant escaping from the radiator. Wrap a thick cloth around the cap. Slowly push down and turn it a quarter turn to allow built-up pressure to escape. Carefully remove the cap by pushing it down and turning it all the way.

#### **NOTE:**

- When removing components such as hoses, tubes/lines, etc., cap or plug openings to prevent fluid from spilling.
- Replace the radiator shroud and cooling fan assembly as a unit. Do not replace cooling fan motors or cooling fan blades separately.

## Removal and Installation

INFOID:000000009460396

### REMOVAL

1. Partially drain engine coolant from the radiator. Refer to [CO-36, "Changing Engine Coolant"](#).

#### **CAUTION:**

- Perform when engine is cold.
- Do not spill coolant on the drive belt.

2. Remove engine room cover. Refer to [EM-28, "Removal and Installation"](#).

# COOLING FAN

[QR25DE]

## < REMOVAL AND INSTALLATION >

3. Remove the core support cover clips (A), then remove the core support cover (1).

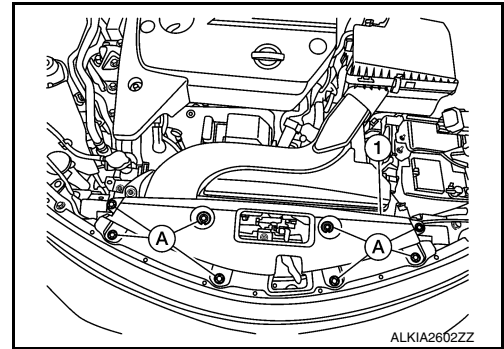

4. Remove front air duct. Refer to [EM-144, "Removal and Installation"](#).
5. Remove air cleaner and air duct assembly. Refer to [EM-29, "Removal and Installation"](#).
6. Remove battery tray and battery tray bracket. Refer to [PG-74, "Removal and Installation \(Battery Tray\)"](#).
7. Disconnect radiator hose (upper) from radiator.
8. Disconnect the harness connectors from the fan motor.
9. Remove fan shroud and motor assembly.

## INSTALLATION

Installation is in the reverse order of removal.

- After installation refill engine coolant and check for leaks. Refer to [CO-36, "Changing Engine Coolant"](#) and [CO-35, "System Inspection"](#).

### **CAUTION:**

- **Do not spill coolant in engine compartment. Use a shop cloth to absorb coolant.**
- Cooling fans are controlled by ECM. Refer to [EC-74, "On Board Diagnosis Function"](#).

# WATER PUMP

< REMOVAL AND INSTALLATION >

[QR25DE]

## WATER PUMP

Exploded View

INFOID:000000009460397

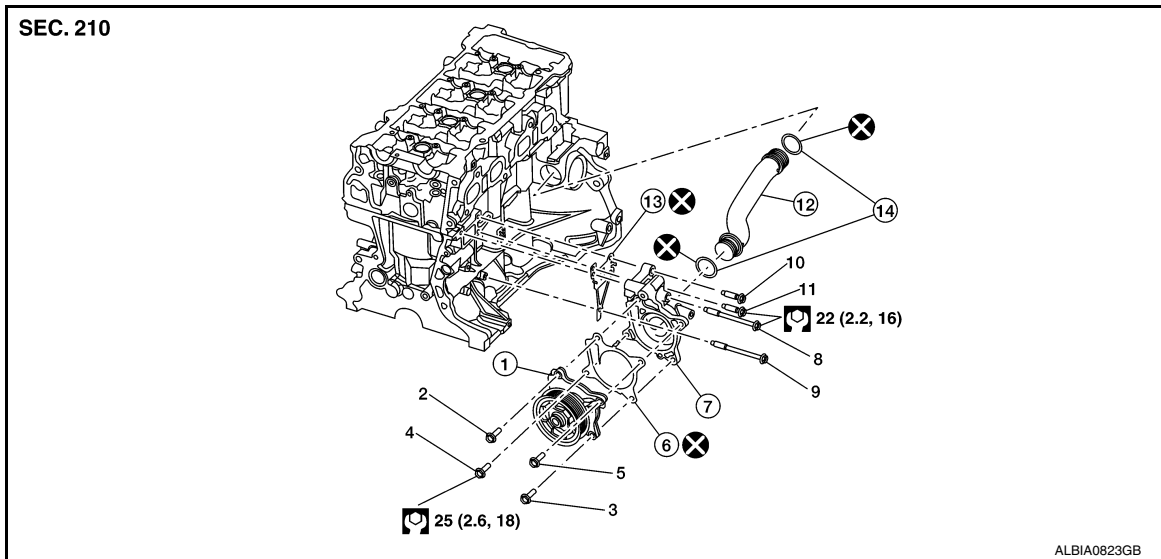

- |                       |                        |                |
|-----------------------|------------------------|----------------|
| 1. Water pump         | 2-5. Tightening order  | 6. Gasket      |
| 7. Water pump housing | 8-11. Tightening order | 12. Water pipe |
| 13. Gasket            | 14. O-ring             |                |

### WARNING:

Do not remove the radiator cap when the engine is hot. Serious burns could occur from high-pressure engine coolant escaping from the radiator. Wrap a thick cloth around the cap. Slowly push down and turn it a quarter turn to allow built-up pressure to escape. Carefully remove the cap by pushing it down and turning it all the way.

### CAUTION:

- When removing water pump assembly, be careful not to get coolant on drive belt.
- Water pump cannot be disassembled and should be replaced as a unit.
- After installing water pump, connect hose and clamp securely, then check for leaks using radiator cap tester.

### NOTE:

When removing components such as hoses, tubes/lines, etc., cap or plug openings to prevent fluid from spilling.

## Removal and Installation

INFOID:000000009460398

### REMOVAL

1. Drain engine coolant from the radiator. Refer to [CO-12, "Changing Engine Coolant"](#).

### CAUTION:

Perform when the engine is cold.

2. Remove the core support cover clips (A), then remove the core support cover (1).

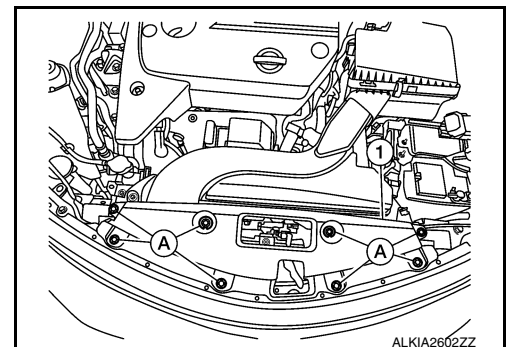

# WATER PUMP

[QR25DE]

## < REMOVAL AND INSTALLATION >

3. Remove fender protector side cover (RH). Refer to [EXT-26. "FENDER PROTECTOR : Removal and Installation"](#).
4. Remove engine under cover. Refer to [EXT-17. "Removal and Installation"](#).
5. Remove engine room cover. Refer to [EXT-17. "Removal and Installation"](#).
6. Remove front air duct. Refer to [EM-84. "Removal and Installation"](#).
7. Remove generator. Refer to [CHG-32. "Removal and Installation"](#).
8. Remove water pump bolts.
9. Remove the water pump and gasket, as necessary.  
**CAUTION:**
  - Handle the water pump vane so that it does not contact any other parts.
  - Water pump cannot be disassembled and should be replaced as an assembly.
10. Remove water pipe, O-rings, water pump housing, and gasket.

### INSPECTION AFTER REMOVAL

- Visually check that there is no significant dirt or rusting on the water pump body and vane.
- Check that there is no looseness in the vane shaft, and that it turns smoothly when rotated by hand.
- If the water pump does not perform properly, replace the water pump assembly.

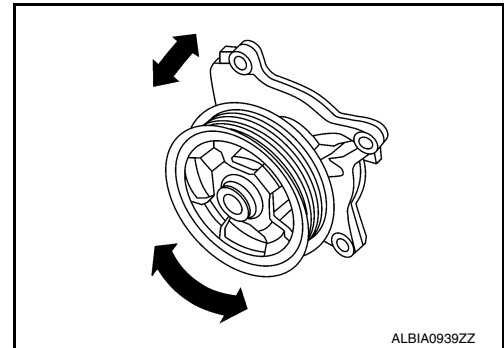

### INSTALLATION

Installation is in the reverse order of removal.

- When inserting water pipe end to cylinder block, apply a mild soap to O-ring. Then insert it immediately.

#### **CAUTION:**

**Do not reuse O-rings.**

**Do not reuse gasket.**

### INSPECTION AFTER INSTALLATION

- After installation refill engine coolant and check for leaks. Refer to [CO-12. "Changing Engine Coolant"](#) and [CO-11. "System Inspection"](#).

# THERMOSTAT AND THERMOSTAT HOUSING

< REMOVAL AND INSTALLATION >

[QR25DE]

## THERMOSTAT AND THERMOSTAT HOUSING

Exploded View

INFOID:000000009460399

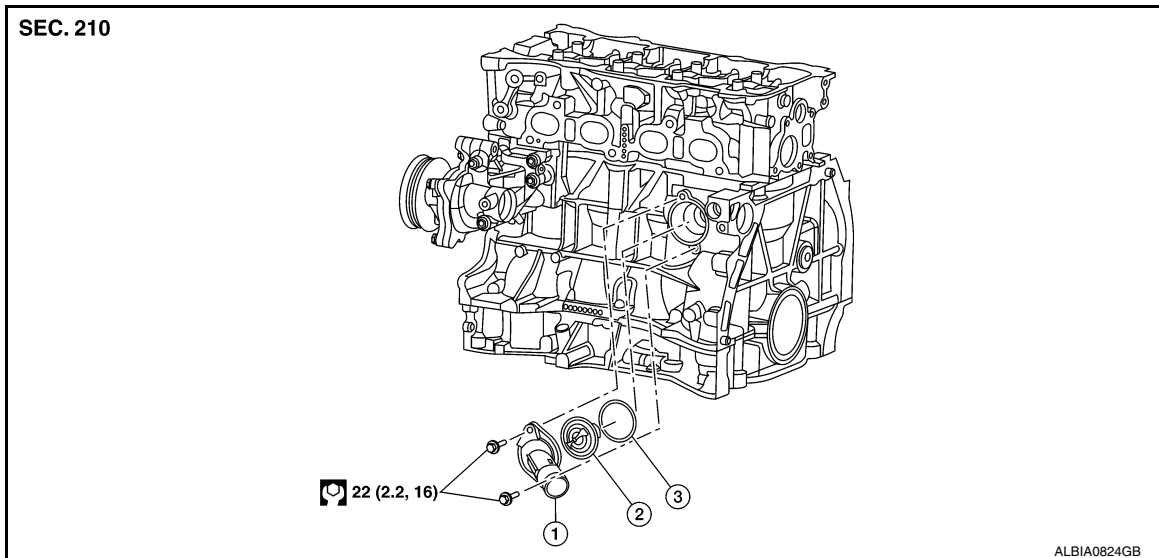

1. Water inlet

2. Thermostat

3. Rubber ring

### WARNING:

Do not remove the radiator cap when the engine is hot. Serious burns could occur from high-pressure engine coolant escaping from the radiator. Wrap a thick cloth around the cap. Slowly push down and turn it a quarter turn to allow built-up pressure to escape. Carefully remove the cap by pushing it down and turning it all the way.

### NOTE:

When removing components such as hoses, tubes/lines, etc., cap or plug openings to prevent fluid from spilling.

## Removal and Installation

INFOID:000000009460400

### REMOVAL

1. Drain engine coolant from the radiator. Refer to [CO-12. "Changing Engine Coolant"](#).

### CAUTION:

Perform when the engine is cold.

2. Remove the core support cover clips (A), then remove the core support cover (1).

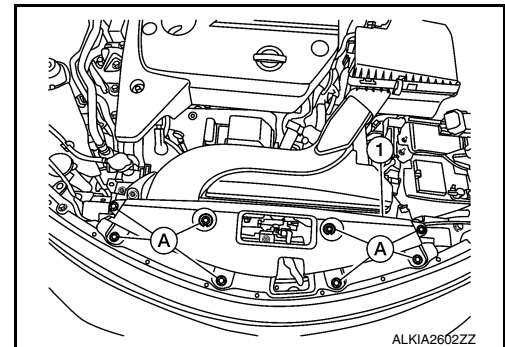

3. Remove the front air duct. Refer to [EM-29. "Removal and Installation"](#).
4. Remove engine under cover. Refer to [EXT-17. "Removal and Installation"](#).
5. Remove radiator hose (lower) from the water inlet side.
6. Remove exhaust manifold heat shield.
7. Remove water inlet and thermostat.

### INSPECTION AFTER REMOVAL

Revision: November 2013

CO-22

2014 Altima NAM

# THERMOSTAT AND THERMOSTAT HOUSING

[QR25DE]

## < REMOVAL AND INSTALLATION >

- Place a thread so that it is caught in the valves of the thermostat. Immerse fully in a container filled with water. Heat while stirring.
- The valve opening temperature is the temperature at which the valve opens and the thermostat falls from the thread.
- Continue heating. Check the full-open lift amount.

**NOTE:**

The full-open lift amount standard temperature for the thermostat is the reference value.

- After checking the full-open lift amount, lower the water temperature and check the valve closing temperature.

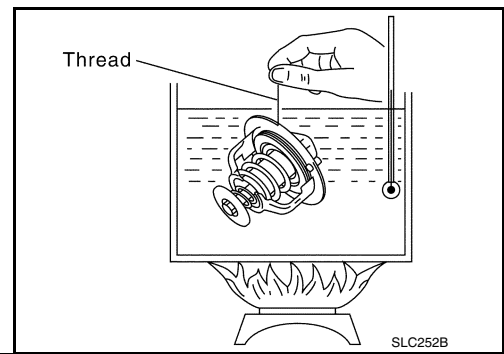

Thermostat	Standard Values
Valve opening temperature	Refer to <a href="#">CO-26. "Thermostat"</a>
Full-open lift amount	Refer to <a href="#">CO-26. "Thermostat"</a>
Valve closing temperature	Refer to <a href="#">CO-26. "Thermostat"</a>

- If valve setting at measured values are out of standard range, replace thermostat.

## INSTALLATION

Installation is in the reverse order of removal.

- Install the thermostat with the whole circumference of the flange fitting securely inside the rubber ring.
- Install the thermostat with the jiggle valve facing upwards. The position deviation may be within the range of  $\pm 10^\circ$ .
- After installation, refill coolant and check for leaks. Refer to [CO-12. "Changing Engine Coolant"](#) and [CO-11. "System Inspection"](#).

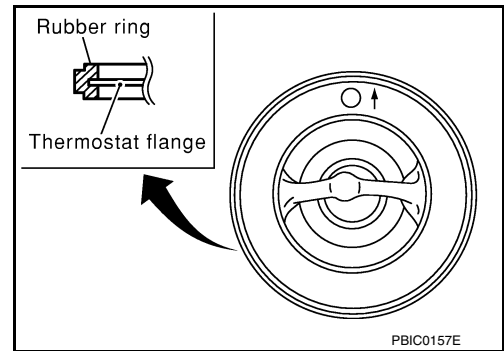

A  
CO  
C  
D  
E  
F  
G  
H  
I  
J  
K  
L  
M  
N  
O  
P

# WATER OUTLET AND WATER PIPING

< REMOVAL AND INSTALLATION >

[QR25DE]

## WATER OUTLET AND WATER PIPING

Exploded View

INFOID:000000009460401

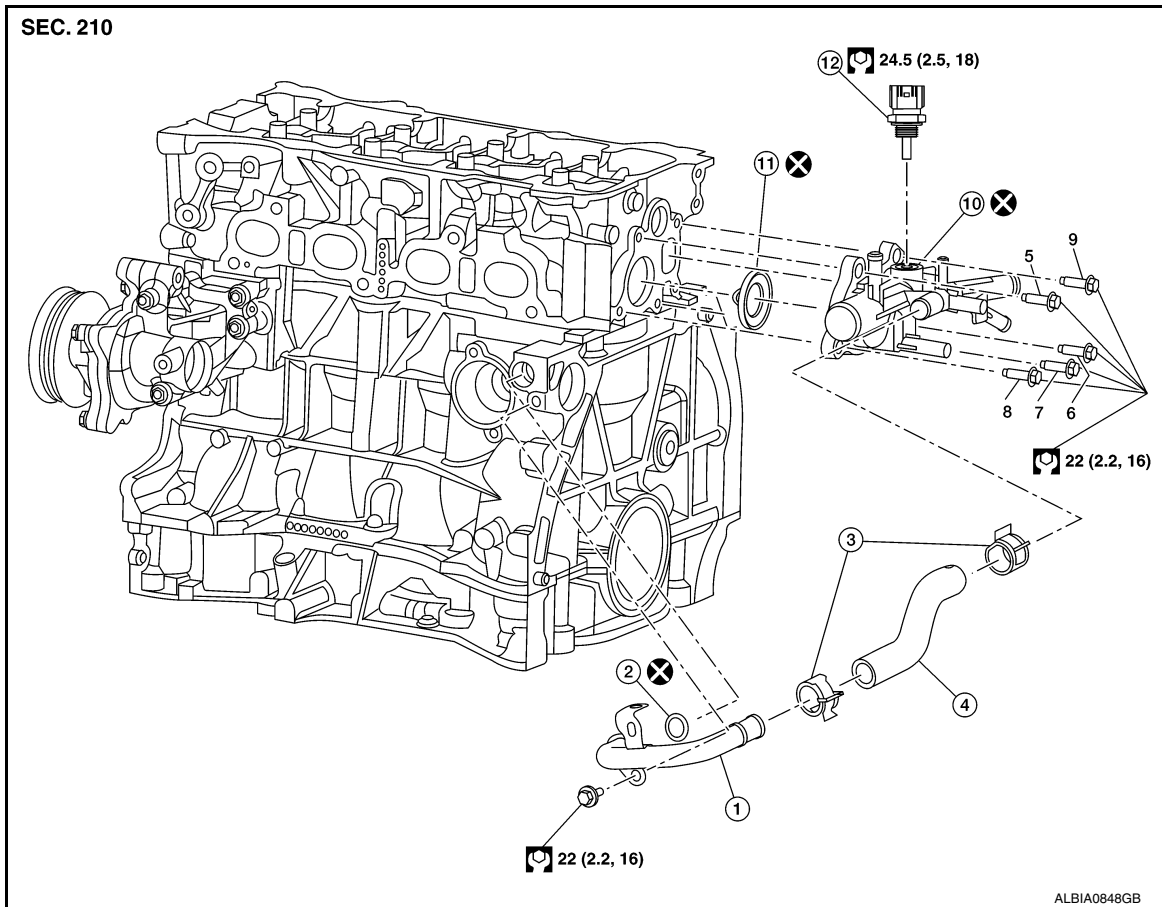

- |                |                       |                  |
|----------------|-----------------------|------------------|
| 1. Heater pipe | 2. O-ring             | 3. Clamp         |
| 4. Water hose  | 5-9. Tightening order | 10. Water outlet |
| 11. O-ring     | 12. Water temp sensor |                  |

### WARNING:

Do not remove the radiator cap when the engine is hot. Serious burns could occur from high-pressure engine coolant escaping from the radiator. Wrap a thick cloth around the cap. Slowly push down and turn it a quarter turn to allow built-up pressure to escape. Carefully remove the cap by pushing it down and turning it all the way.

### NOTE:

When removing components such as hoses, tubes/lines, etc., cap or plug openings to prevent fluid from spilling.

## Removal and Installation

INFOID:000000009460402

### REMOVAL

1. Drain engine coolant from the radiator. Refer to [CO-12. "Changing Engine Coolant"](#).

### CAUTION:

Perform when the engine cold.



# WATER OUTLET AND WATER PIPING

[QR25DE]

## < REMOVAL AND INSTALLATION >

2. Remove the core support cover clips (A), then remove the core support cover (1).

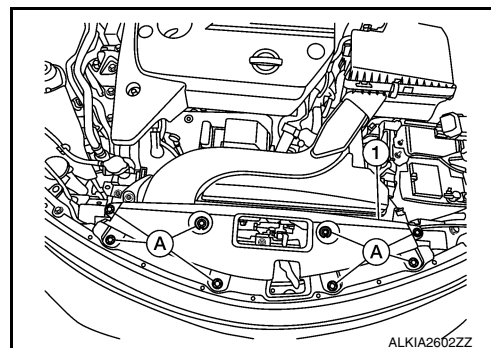

3. Remove air cleaner assembly and front air duct. Refer to [EM-84, "Removal and Installation"](#).
4. Remove the engine room cover. Refer to [EM-28, "Removal and Installation"](#).
5. Remove the upper radiator hose, heater pipe, electric throttle control actuator inlet hose, water hose, and water temperature sensor.
6. Remove the water outlet, O-ring and gasket.  
**CAUTION:**
  - Do not reuse O-ring.
  - Do not reuse gasket.
  - Do not reuse water outlet.

## INSTALLATION

Installation is in the reverse order of removal.

- Install the engine coolant temperature sensor.  
**Use Genuine RTV Silicone Sealant or equivalent. Refer to [GI-21, "Recommended Chemical Products and Sealants"](#).**
- Install the heater pipe, first apply a mild soap to the O-ring and quickly insert the heater pipe into the housing.  
**CAUTION:**
  - Do not reuse O-ring.
  - Do not reuse gasket.
  - Do not reuse water outlet.
- After installation, refill coolant and check for leaks. Refer to [CO-12, "Changing Engine Coolant"](#) and [CO-11, "System Inspection"](#).  
**CAUTION:**  
**Do not spill coolant in engine compartment. Use a shop cloth to absorb coolant.**

## SERVICE DATA AND SPECIFICATIONS (SDS)

< SERVICE DATA AND SPECIFICATIONS (SDS)

[QR25DE]

## SERVICE DATA AND SPECIFICATIONS (SDS)

### SERVICE DATA AND SPECIFICATIONS (SDS)

#### Capacity

INFOID:000000009460403

ℓ (US qt, Imp qt)

Coolant capacity (With reservoir tank at MAX level)	7.9 (8-3/8, 7)*
---	-----------------

\*Includes MAX-line quantity (0.75 L) of reservoir tank.

#### Thermostat

INFOID:000000009460404

Valve opening temperature	80.5 - 83.5°C (177 - 182°F)
Full-open lift amount	More than 8 mm / 95°C (0.315 in / 203°F)
Valve closing temperature	77°C (171°F) or higher

#### Radiator

INFOID:000000009460405

Unit: kPa (kg/cm<sup>2</sup>, psi)

Cap relief pressure	Standard	127 ± 9.8 (1.30 ± 0.10, 18.4 ± 1.42)
Testing pressure		156 (1.6, 23)

PRECAUTION

PRECAUTIONS

Precaution for Supplemental Restraint System (SRS) "AIR BAG" and "SEAT BELT PRE-TENSIONER"

INFOID:000000009951690

The Supplemental Restraint System such as "AIR BAG" and "SEAT BELT PRE-TENSIONER", used along with a front seat belt, helps to reduce the risk or severity of injury to the driver and front passenger for certain types of collision. Information necessary to service the system safely is included in the SR and SB section of this Service Manual.

**WARNING:**

- To avoid rendering the SRS inoperative, which could increase the risk of personal injury or death in the event of a collision which would result in air bag inflation, all maintenance must be performed by an authorized NISSAN/INFINITI dealer.
- Improper maintenance, including incorrect removal and installation of the SRS, can lead to personal injury caused by unintentional activation of the system. For removal of Spiral Cable and Air Bag Module, see the SR section.
- Do not use electrical test equipment on any circuit related to the SRS unless instructed to in this Service Manual. SRS wiring harnesses can be identified by yellow and/or orange harnesses or harness connectors.

PRECAUTIONS WHEN USING POWER TOOLS (AIR OR ELECTRIC) AND HAMMERS

**WARNING:**

- When working near the Airbag Diagnosis Sensor Unit or other Airbag System sensors with the Ignition ON or engine running, DO NOT use air or electric power tools or strike near the sensor(s) with a hammer. Heavy vibration could activate the sensor(s) and deploy the air bag(s), possibly causing serious injury.
- When using air or electric power tools or hammers, always switch the Ignition OFF, disconnect the battery and wait at least three minutes before performing any service.

Precaution for Liquid Gasket

INFOID:000000009460407

REMOVAL OF LIQUID GASKET

- After removing the bolts and nuts, separate the mating surface and remove the liquid gasket using Tool (A).

Tool Number (A): KV10111100 (J-37228)

**CAUTION:**

Be careful not to damage the mating surfaces.

- In areas where the cutter is difficult to use, use a plastic hammer to lightly tap (1) the cutter where the liquid gasket is applied. Use a plastic hammer to slide (2) the cutter by tapping on the side.

**CAUTION:**

Do not damage the mating surfaces.

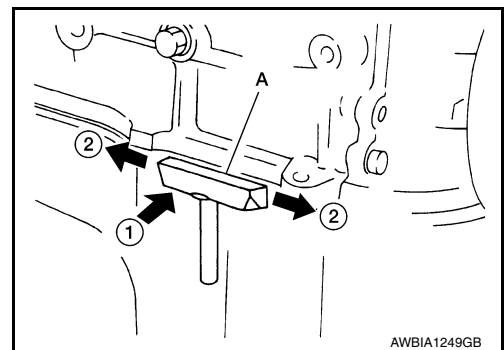

LIQUID GASKET APPLICATION PROCEDURE

1. Using a scraper, remove the old liquid gasket adhering to the gasket application surface and the mating surface.
  - Remove the liquid gasket completely from the groove of the gasket application surface, mounting bolts, and bolt holes.
2. Thoroughly clean the gasket application surface and the mating surface and remove adhering moisture, grease and foreign materials.
3. Attach the liquid gasket tube to the tube presser. Use Genuine Silicone RTV Sealant or equivalent. Refer to [GI-21, "Recommended Chemical Products and Sealants"](#).

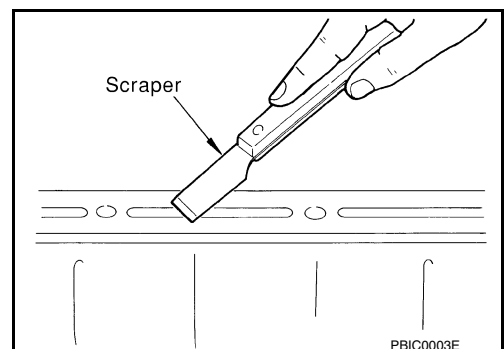

# PRECAUTIONS

[VQ35DE]

## < PRECAUTION >

4. Apply the liquid gasket using suitable tool without breaks to the specified location.
  - If there is a groove for the liquid gasket application, apply the liquid gasket to the groove.
  - As for the bolt holes, normally apply the liquid gasket inside the holes. If specified, it should be applied outside the holes. Make sure to read the text of this manual.
  - Within five minutes of the liquid gasket application, install the mating component.
  - If the liquid gasket protrudes, wipe it off immediately.
  - Do not retighten after the installation.

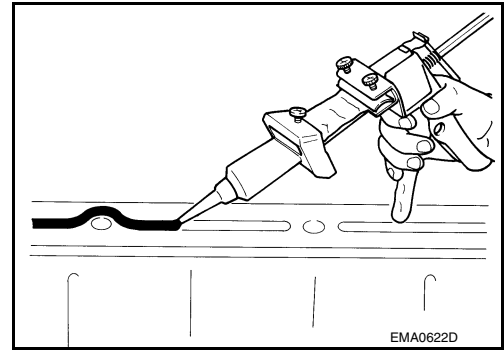

- After 30 minutes or more have passed from the installation, fill the engine with the specified oil and coolant. Refer to [MA-11](#), "[FOR USA AND CANADA : Fluids and Lubricants](#)".

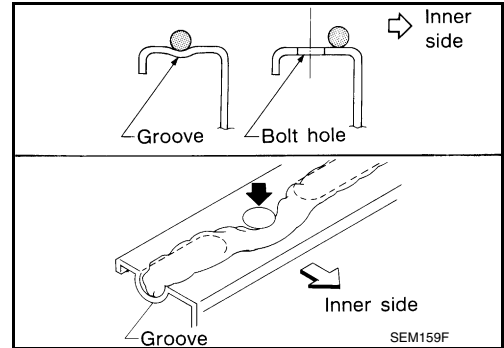

### **CAUTION:**

If there are more specific instructions in the procedures contained in this manual concerning liquid gasket application, observe them.

# PREPARATION

< PREPARATION >

[VQ35DE]

## PREPARATION

### PREPARATION

#### Special Service Tool

INFOID:000000009460408

A

CO

The actual shapes of the tools may differ from those illustrated here.

Tool number (TechMate No.) Tool name	Description
EG17650301 (J-33984-A) Radiator cap tester adapter	Adapting radiator cap tester to radiator cap and radiator filler neck <b>a: 28 (1.10) dia.</b> <b>b: 31.4 (1.236) dia.</b> <b>c: 41.3 (1.626) dia.</b> Unit: mm (in)
KV10111100 (J-37228) Seal cutter	Removing chain tensioner cover and water pump cover
KV991J0070 (J-45695) Coolant Refill Tool	Refilling engine cooling system
— (J-23688) Engine coolant refractometer	Checking concentration of ethylene glycol in engine coolant

C

D

E

F

G

H

I

J

K

L

M

#### Commercial Service Tool

INFOID:000000009460409

N

O

P

# PREPARATION

< PREPARATION >

[VQ35DE]

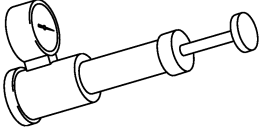
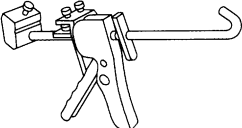
Tool name	Description
<p data-bbox="164 197 272 222">Power tool</p>  <p data-bbox="829 415 894 432">PIIB1407E</p>	<p data-bbox="1013 197 1344 222">Loosening nuts, screws and bolts</p>
<p data-bbox="164 449 354 474">Radiator cap tester</p>  <p data-bbox="829 667 894 684">PBIC1982E</p>	<p data-bbox="1013 449 1214 474">Testing radiator cap</p>
<p data-bbox="164 701 310 726">Tube pressure</p>  <p data-bbox="829 919 886 936">S-NT052</p>	<p data-bbox="1013 701 1344 726">Pressing the tube of liquid gasket</p>

## SYSTEM DESCRIPTION

### COOLING SYSTEM

#### Cooling Circuit

INFOID:000000009460410

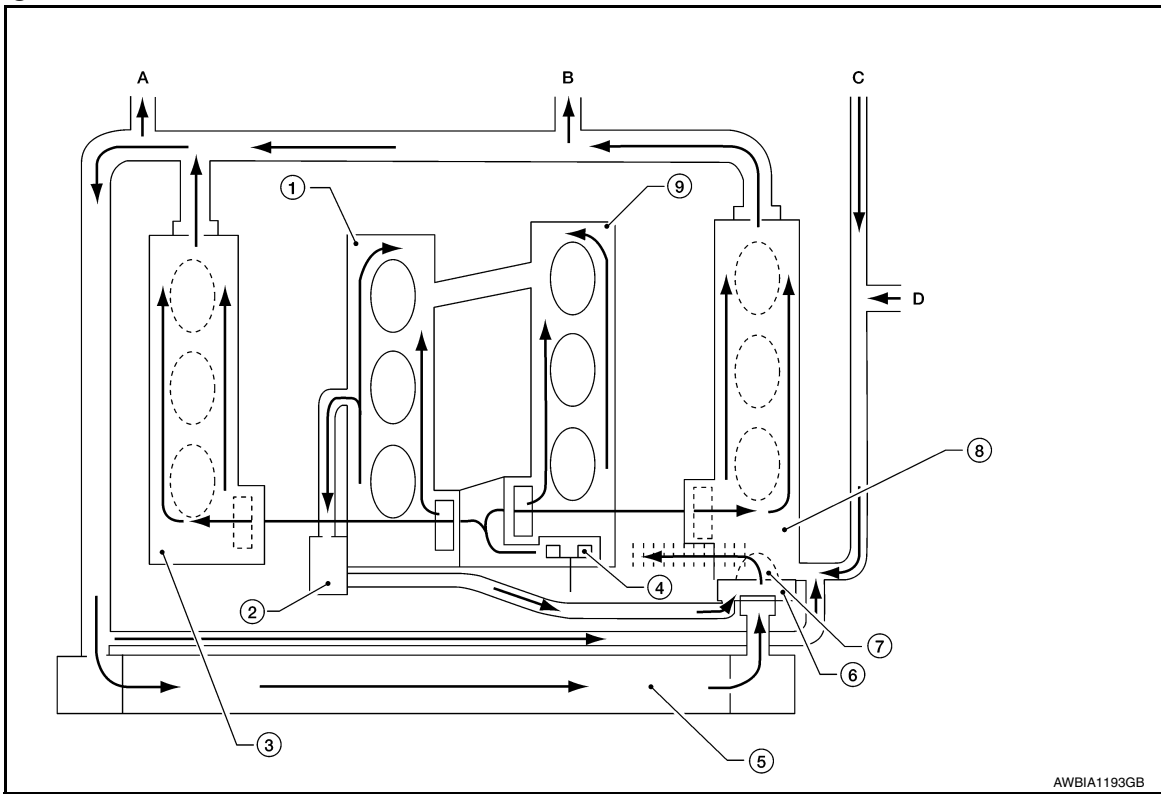

- |  |  |                        |
|--|--|------------------------|
| 1. Cylinder block (RH)                     | 2. Oil cooler                            | 3. Cylinder head (RH)  |
| 4. Water pump                              | 5. Radiator                              | 6. Water inlet         |
| 7. Thermostat                              | 8. Cylinder head (LH)                    | 9. Cylinder block (LH) |
| A. To heater                               | B. To electric throttle control actuator | C. From heater         |
| D. From electric throttle control actuator |  |                        |

# COOLING SYSTEM

< SYSTEM DESCRIPTION >

[VQ35DE]

## Schematic

INFOID:000000009460411

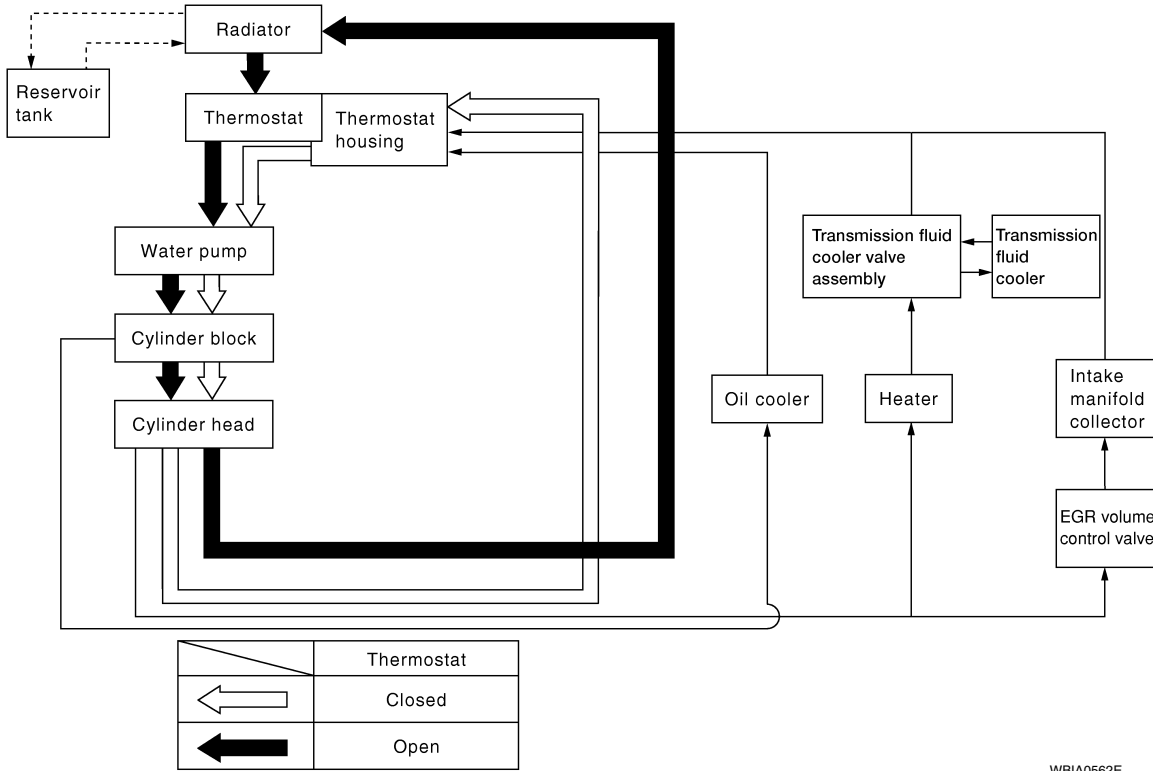

WBIA0562E



# OVERHEATING CAUSE ANALYSIS

< SYSTEM DESCRIPTION >

[VQ35DE]

## OVERHEATING CAUSE ANALYSIS

### Troubleshooting Chart

INFOID:000000009460412

		Symptom	Check items		
Cooling system parts malfunction	Poor heat transfer	Water pump malfunction	Worn or loose drive belt	—	
		Thermostat stuck closed	Coolant circulation		
		Damaged fins	Dust contamination or paper clogging		
			Physical damage		
		Clogged radiator cooling tube	Excess foreign material (rust, dirt, sand, etc.)		
	Reduced air flow	Cooling fan does not operate	Fan assembly	—	
		High resistance to fan rotation			
		Damaged fan blades			
		Damaged radiator shroud	—	Radiator shroud	—
		Improper coolant mixture ratio	—	Coolant viscosity	—
		Poor coolant quality	—		—
	Insufficient coolant	Coolant leaks	Cooling hose	Loose clamp	
				Cracked hose	
			Water pump	Poor sealing	
			Radiator cap	Loose	
Poor sealing					
Radiator			O-ring for damage, deterioration or improper fitting		
		Cracked radiator tank			
		Cracked radiator core			
	Reservoir tank	Cracked reservoir tank			
Overflowing reservoir tank	Exhaust gas leaks into cooling system	Cylinder head deterioration			
		Cylinder head gasket deterioration			

A  
CO  
C  
D  
E  
F  
G  
H  
I  
J  
K  
L  
M  
N  
O  
P

# OVERHEATING CAUSE ANALYSIS

< SYSTEM DESCRIPTION >

[VQ35DE]

	Symptom		Check items				
Except cooling system parts malfunction	—	Overload on engine	Abusive driving	High engine rpm under no load			
				Driving in low gear for extended time			
				Driving at extremely high speed			
			Blocked or restricted air flow	Blocked bumper	Blocked air flow	—	
					Blocked radiator grille		Installed car brassiere
					Blocked radiator		Mud contamination or paper clogging
	Blocked or restricted air flow	Blocked condenser	Blocked air flow	—			
		Installed large fog lamp					

# PERIODIC MAINTENANCE

## ENGINE COOLANT

### System Inspection

INFOID:000000009460413

#### **WARNING:**

Do not remove the radiator cap when the engine is hot. Serious burns could occur from high-pressure engine coolant escaping from the radiator. Wrap a thick cloth around the cap. Slowly push down and turn it a quarter turn to allow built-up pressure to escape. Carefully remove the cap by pushing it down and turning it all the way.

#### CHECKING COOLING SYSTEM HOSES

Check hoses for the following:

- Improper attachment
- Leaks
- Cracks
- Damage
- Loose connections
- Chafing
- Deterioration

#### CHECKING RESERVOIR LEVEL

- Check if the reservoir tank coolant level is within MIN to MAX range when the engine is cool.
- Adjust coolant level if it is too much or too little.

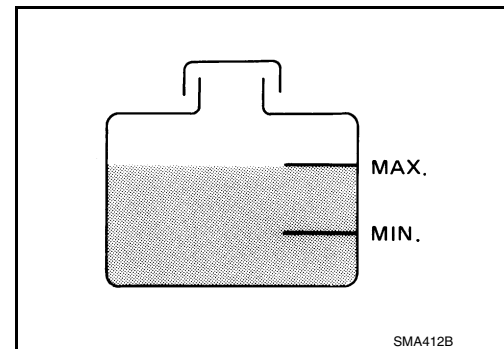

#### CHECKING COOLING SYSTEM FOR LEAKS

To check for leaks, apply pressure to the cooling system using suitable tool (A) and Tool (B).

**Tool number** : EG17650301 (J-33984-A)

**Testing pressure** : Refer to [CO-53, "Radiator"](#).

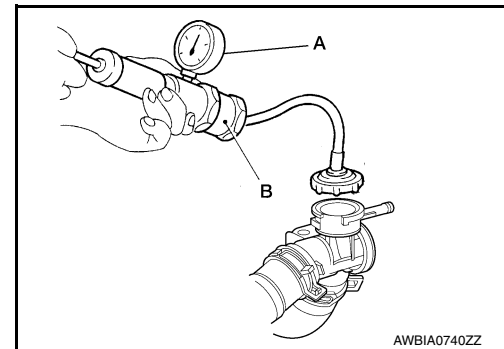

#### **WARNING:**

Do not remove the radiator cap when the engine is hot. Serious burns could occur from high pressure coolant escaping from the radiator.

#### **CAUTION:**

Higher pressure than specified may cause radiator damage.

#### CHECKING RADIATOR CAP

1. Inspect the radiator cap.
  - Replace the cap if the metal plunger cannot be seen around the edge of the black rubber gasket.
  - Replace the cap if deposits of waxy residue or other foreign material are on the black rubber gasket or the metal retainer.

#### **NOTE:**

Thoroughly wipe out the radiator filler neck to remove any waxy residue or foreign material.

# ENGINE COOLANT

[VQ35DE]

## < PERIODIC MAINTENANCE >

2. Pull the negative-pressure valve to open it and check that it closes completely when released.
  - Check that there is no dirt or damage on the valve seat of the radiator cap negative-pressure valve.
  - Check that there are no abnormalities in the opening and closing conditions of the negative-pressure valve.

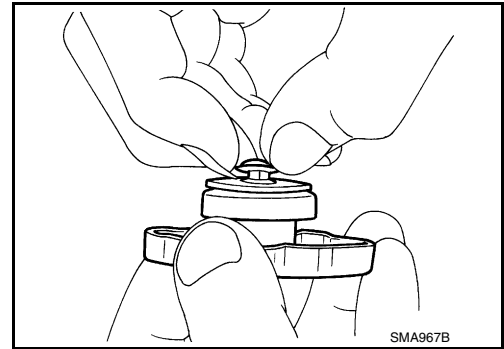

3. Check radiator cap relief pressure using suitable tool and Tool.

**Tool number** : EG17650301 (J-33984-A)

**Standard** : Refer to [CO-53, "Radiator"](#).

- When connecting the radiator cap to the tester, apply water or coolant to the cap seal surface.
- Replace the radiator cap if there is an abnormality in the negative-pressure valve, or if the open-valve pressure is outside of the standard values.

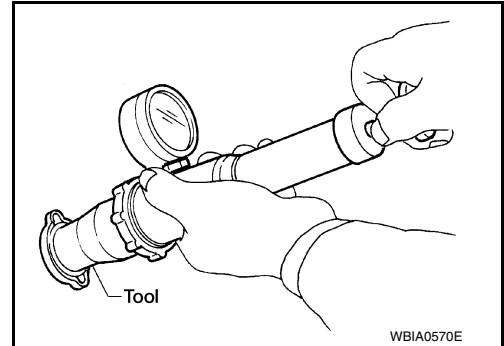

## CHECKING RADIATOR

Check radiator for mud or clogging. If necessary, clean radiator as follows.

### CAUTION:

- **Be careful not to bend or damage the radiator fins.**
- **When radiator is cleaned on-vehicle, remove surrounding parts in order to access the radiator core. Tape the harness and electrical connectors to prevent water from entering.**

1. Spray water to the back side of the radiator core using a side to side motion from the top down.
2. Stop spraying when debris no longer flows from radiator core.
3. Blow air into the back side of radiator core using a side to side motion from the top down.
  - Use compressed air lower than 490 kPa (5 kg/cm<sup>2</sup>, 71 psi) and keep distance more than 30 cm (11.8 in).
4. Continue to blow air until no water sprays out.
5. Check for coolant leaks. Repair as necessary.

## Changing Engine Coolant

INFOID:000000009460414

### WARNING:

**Do not remove the radiator cap when the engine is hot. Serious burns could occur from high-pressure engine coolant escaping from the radiator. Wrap a thick cloth around the cap. Slowly push down and turn it a quarter turn to allow built-up pressure to escape. Carefully remove the cap by pushing it down and turning it all the way.**

## DRAINING ENGINE COOLANT

1. Remove the engine under cover. Refer to [EXT-17, "Removal and Installation"](#).
2. Open the radiator drain plug at the bottom of the radiator and remove the radiator filler cap. This is the only step required when partially draining the cooling system (radiator only).

### CAUTION:

- **Do not allow the coolant to contact the drive belts.**
  - **Perform this step when engine is cold.**
3. Follow this step for heater core removal/replacement only. Disconnect the upper heater hose at the engine side and apply moderate air pressure [103.46 kPa (1.055 kg/cm<sup>2</sup>, 15 psi) maximum air pressure] into the hose for 30 seconds to blow the excess coolant out of the heater core.
  4. When draining all of the coolant in the system, remove the reservoir tank and drain the coolant, then clean the reservoir tank before installation.

### CAUTION:

# ENGINE COOLANT

[VQ35DE]

## < PERIODIC MAINTENANCE >

- Do not allow the coolant to contact the drive belts.
  - Perform this step when engine is cold.
5. When draining all of the coolant in the system for engine removal or repair, open all of the drain plugs (A-D) on the cylinder block.
  6. Check the drained coolant for contaminants such as rust, corrosion or discoloration.  
If the coolant is contaminated, flush the engine cooling system.

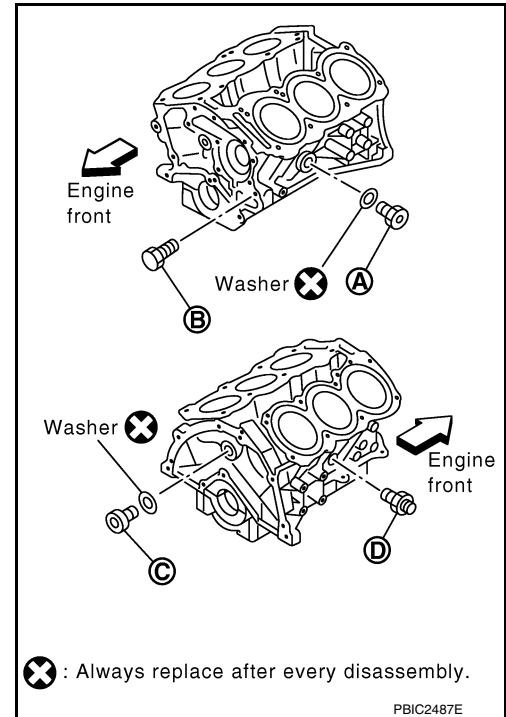

## REFILLING ENGINE COOLANT

1. Install the radiator drain plug. If the cooling system was drained completely, install the reservoir tank and the cylinder block drain plugs.
  - The radiator must be completely empty of coolant and water.
  - Apply sealant to the threads of the cylinder block drain plug. Use **Genuine High Performance Thread Sealant** or equivalent. Refer to [GI-21, "Recommended Chemical Products and Sealants"](#).

### CAUTION:

Do not reuse copper sealing washers.

Radiator drain plug	: Refer to <a href="#">CO-16, "Exploded View"</a>
Cylinder block front drain plug (LH) (A) (except Canada)	: 62.0 N·m (6.3 kg-m, 46 ft-lb)
Cylinder block water drain plug (B)	: 6.0 N·m (0.6 kg-m, 53 in-lb)
Cylinder block rear drain plug (C)	: 78.0 N·m (8.0 kg-m, 58 ft-lb)
Cylinder block RH banjo bolt (D) (oil cooler)	: 19.6 N·m (2.0 kg-m, 14 ft-lb)

2. If disconnected, reattach the upper radiator hose at the engine side.
3. Set the vehicle heater controls to the full HOT and heater ON position. Turn the vehicle ignition ON with the engine OFF as necessary to activate the heater mode.

# ENGINE COOLANT

[VQ35DE]

## < PERIODIC MAINTENANCE >

4. Install the Tool by installing the radiator cap adapter onto the radiator neck opening. Then attach the gauge body assembly with the refill tube and the venturi assembly to the radiator cap adapter.

**Tool number** : KV991J0070 (J-45695)

5. Insert the refill hose into the coolant mixture container that is placed at floor level. Make sure the ball valve is in the closed position.

- **Use recommended coolant or equivalent.**

Refer to [MA-11, "FOR USA AND CANADA : Fluids and Lubricants"](#).

**Engine coolant capacity** : Refer to [CO-53, "Capacity"](#).  
(with reservoir tank)

**CAUTION:**

**Do not use any cooling system additives such as radiator sealer. Additives may clog the cooling system and cause damage to the engine, transmission and/or cooling system.**

6. Install an air hose to the venturi assembly, the air pressure must be within specification.

**Compressed air supply pressure** : 549 - 824 kPa (5.6 - 8.4 kg/cm<sup>2</sup>,  
80 - 119 psi)

**CAUTION:**

**The compressed air supply must be equipped with an air dryer.**

7. The vacuum gauge will begin to rise and there will be an audible hissing noise. During this process open the ball valve on the refill hose slightly. Coolant will be visible rising in the refill hose. Once the refill hose is full of coolant, close the ball valve. This will purge any air trapped in the refill hose.
8. Continue to draw the vacuum until the gauge reaches 28 inches of vacuum. The gauge may not reach 28 inches in high altitude locations, use the vacuum specifications based on the altitude above sea level.

Altitude above sea level	Vacuum gauge reading
0 - 100 m (328 ft)	: 28 inches of vacuum
300 m (984 ft)	: 27 inches of vacuum
500 m (1,641 ft)	: 26 inches of vacuum
1,000 m (3,281 ft)	: 24 - 25 inches of vacuum

9. When the vacuum gauge has reached the specified amount, disconnect the air hose and wait 20 seconds to see if the system loses any vacuum. If the vacuum level drops, perform any necessary repairs to the system and repeat steps 6 - 8 to bring the vacuum to the specified amount. Recheck for any leaks.
10. Place the coolant container (with the refill hose inserted) at the same level as the top of the radiator. Then open the ball valve on the refill hose so the coolant will be drawn up to fill the cooling system. The cooling system is full when the vacuum gauge reads zero.

**CAUTION:**

**Do not allow the coolant container to get too low when filling, to avoid air from being drawn into the cooling system.**

11. Remove the Tool from the radiator neck opening.
12. Fill the cooling system reservoir tank to the specified level and install the radiator cap. Run the engine to warm up the cooling system and top up the system as necessary.
13. Install the engine under cover. Refer to [EXT-17, "Removal and Installation"](#).

## FLUSHING COOLING SYSTEM

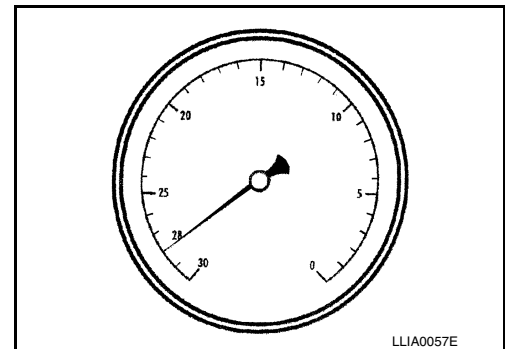
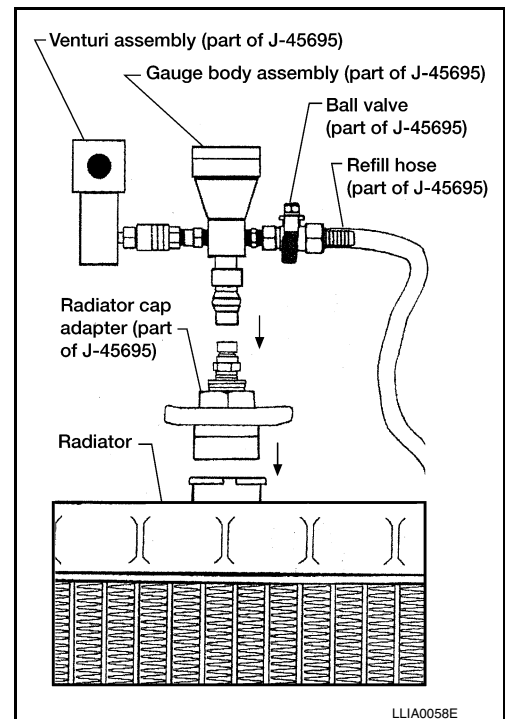

## ENGINE COOLANT

[VQ35DE]

< PERIODIC MAINTENANCE >

1. Fill the radiator from the filler neck above the radiator upper hose and reservoir tank with clean water and reinstall radiator filler cap. A
2. Run the engine until it reaches normal operating temperature.
3. Rev the engine two or three times under no-load.
4. Stop the engine and wait until it cools down. CO
5. Drain the water from the system. Refer to [CO-36. "Changing Engine Coolant"](#).
6. Repeat steps 1 through 5 until clear water begins to drain from the radiator. C

C

D

E

F

G

H

I

J

K

L

M

N

O

P

# RADIATOR

< REMOVAL AND INSTALLATION >

[VQ35DE]

## REMOVAL AND INSTALLATION

### RADIATOR

Exploded View

INFOID:000000009460415

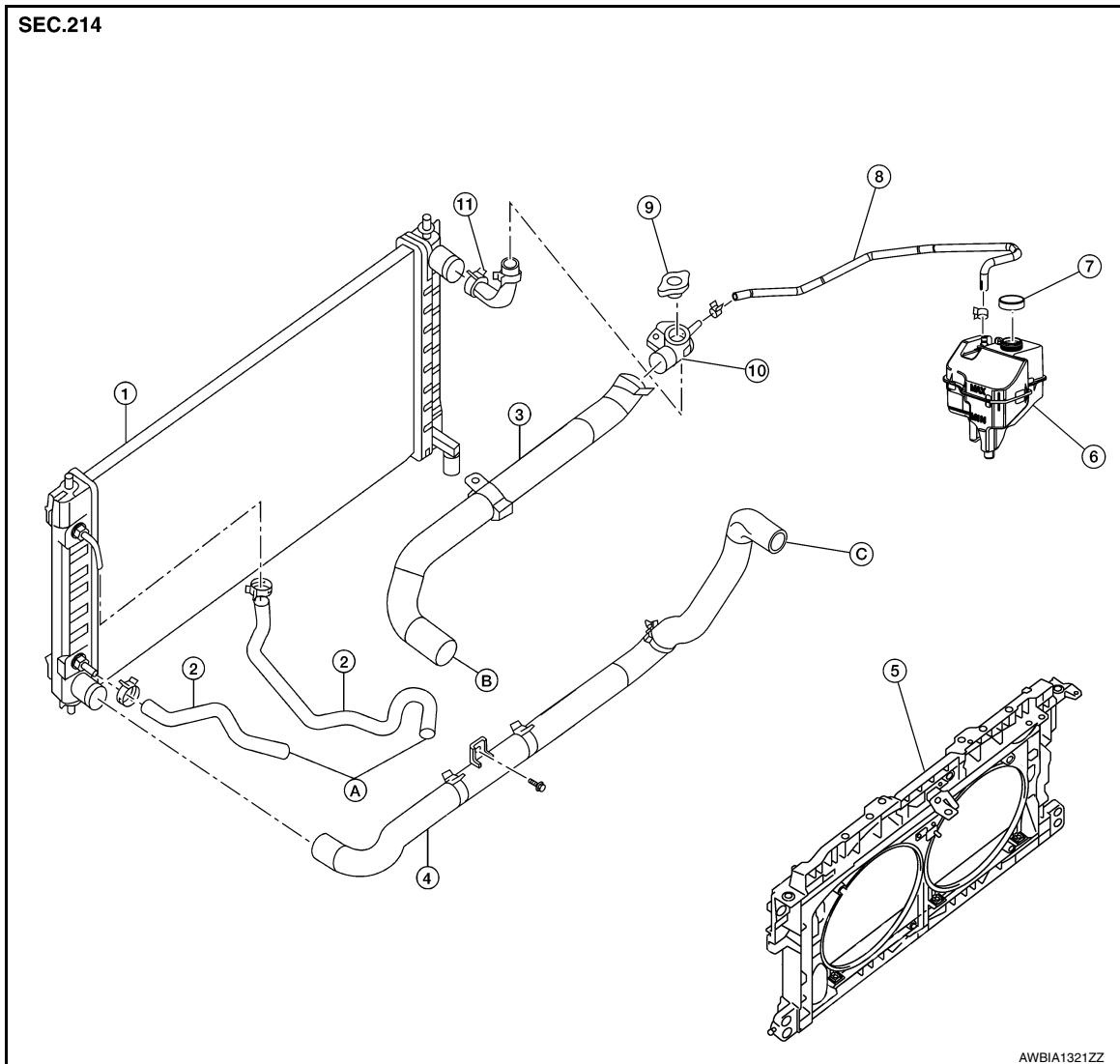

- |                          |                          |                          |
|--------------------------|--------------------------|--------------------------|
| 1. Radiator              | 2. CVT oil cooler hose   | 3. Radiator hose (upper) |
| 4. Radiator hose (lower) | 5. Radiator core support | 6. Reservoir tank        |
| 7. Reservoir tank cap    | 8. Reservoir tank hose   | 9. Radiator filler cap   |
| 10. Filler neck          | 11. Filler neck hose     | A. To CVT                |
| B. To water outlet       | C. To water inlet        |                          |

#### **WARNING:**

Do not remove the radiator cap when the engine is hot. Serious burns could occur from high-pressure engine coolant escaping from the radiator. Wrap a thick cloth around the cap. Slowly push down and turn it a quarter turn to allow built-up pressure to escape. Carefully remove the cap by pushing it down and turning it all the way.

#### **NOTE:**

When removing components such as hoses, tubes/lines, etc., cap or plug openings to prevent fluid from spilling.



# RADIATOR

< REMOVAL AND INSTALLATION >

[VQ35DE]

INFOID:000000009460416

## Removal and Installation

### REMOVAL

1. Remove radiator cap and drain coolant from radiator. Refer to [CO-12, "Changing Engine Coolant"](#).  
**CAUTION:**
  - Perform this step when the engine is cold.
  - Do not spill coolant on the drive belt.
2. Remove front air duct. Refer to [EM-29, "Removal and Installation"](#).
3. Disconnect coolant reservoir hose from the radiator.
4. Remove fender protector side cover (LH/RH). Refer to [EXT-26, "FENDER PROTECTOR : Exploded View"](#).
5. Disconnect radiator hose (upper) and radiator hose (lower) from the radiator.  
**CAUTION:**  
**Do not allow the coolant to contact the drive belt.**  
**NOTE:**  
The radiator hose clamps on the radiator hose (upper) and on the radiator hose (lower), are not serviced separately. Radiator hose clamps are part of the radiator hose assembly and serviced as one unit with the radiator hose.
6. Disconnect the CVT oil cooler hoses.
7. Remove the front bumper fascia. Refer to [EXT-17, "Removal and Installation"](#).
8. Remove A/C condenser. Refer to [HA-30, "COMPRESSOR : Removal and Installation"](#).  
**CAUTION:**  
**Be careful not to damage condenser core.**
9. Remove the radiator mounts (upper).
10. Remove radiator.  
**CAUTION:**  
**Do not damage or scratch the radiator core when removing.**

### INSTALLATION

Installation is in the reverse order of removal.

- After installation, refill coolant and check for leaks. Refer to [CO-12, "Changing Engine Coolant"](#) and [CO-11, "System Inspection"](#).

#### **CAUTION:**

**Do not spill coolant in engine compartment. Use a shop cloth to absorb coolant.**

### Inspection

INFOID:000000009460417

### INSPECTION AFTER INSTALLATION

- Check that the reservoir tank cap is tightened.
- Check for leakage of engine coolant using Tool (B) and suitable tool (A). Refer to [CO-35, "System Inspection"](#).

**Tool number** : EG17650301 (J-33984-A)

**Testing pressure** : Refer to [CO-53, "Radiator"](#).

#### **WARNING:**

**Do not remove the radiator cap when the engine is hot. Serious burns could occur from high pressure coolant escaping from the radiator.**

#### **CAUTION:**

**Higher pressure than specified may cause radiator damage.**

- Start and warm up the engine. Visually check that there is no leakage of engine coolant and CVT fluid (CVT models).

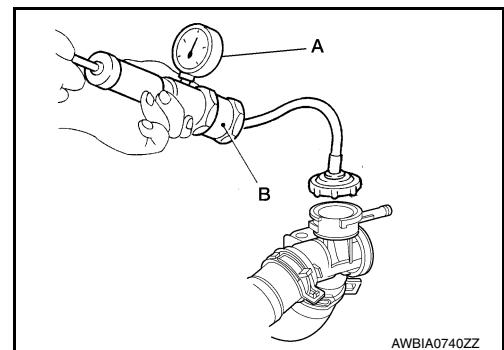

# COOLING FAN

< REMOVAL AND INSTALLATION >

[VQ35DE]

## COOLING FAN

### Exploded View

INFOID:000000009460418

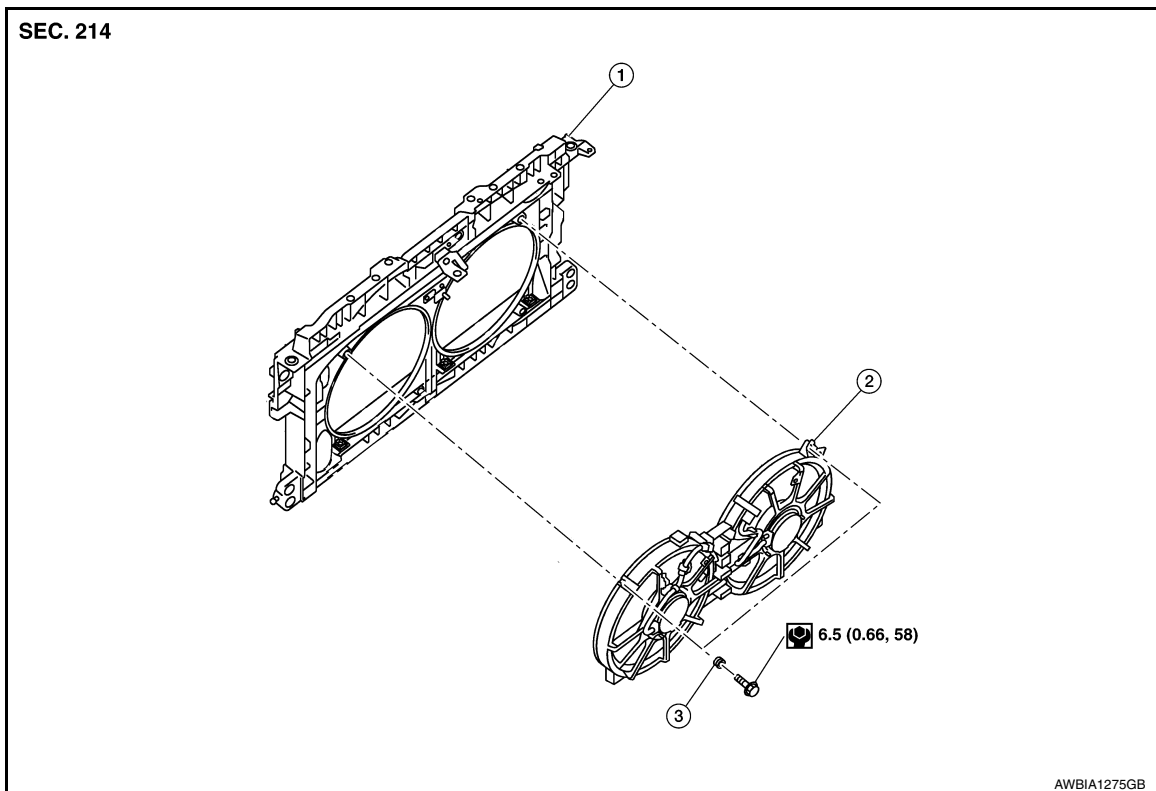

1. Radiator core support

2. Fan shroud and motor assembly

3. Grommet

#### WARNING:

Do not remove the radiator cap when the engine is hot. Serious burns could occur from high-pressure engine coolant escaping from the radiator. Wrap a thick cloth around the cap. Slowly push down and turn it a quarter turn to allow built-up pressure to escape. Carefully remove the cap by pushing it down and turning it all the way.

#### NOTE:

- When removing components such as hoses, tubes/lines, etc., cap or plug openings to prevent fluid from spilling.
- Replace the radiator shroud and cooling fan assembly as a unit. Do not replace cooling fan motors or cooling fan blades separately.

## Removal and Installation

INFOID:000000009460419

### REMOVAL

1. Partially drain engine coolant from the radiator. Refer to [CO-36, "Changing Engine Coolant"](#).

#### CAUTION:

- Perform when engine is cold.
- Do not spill coolant on the drive belt.

2. Remove engine room cover. Refer to [EM-28, "Removal and Installation"](#).

# COOLING FAN

[VQ35DE]

## < REMOVAL AND INSTALLATION >

3. Remove the core support cover clips (A), then remove the core support cover (1).

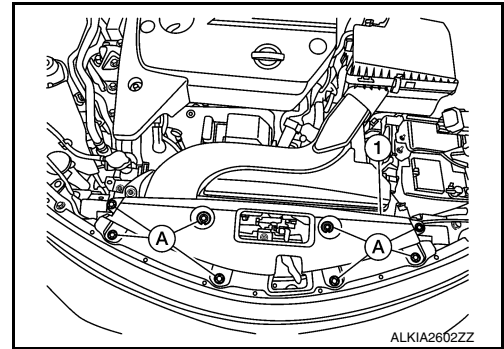

4. Remove front air duct. Refer to [EM-144, "Removal and Installation"](#).
5. Remove air cleaner and air duct assembly. Refer to [EM-29, "Removal and Installation"](#).
6. Remove battery tray and battery tray bracket. Refer to [PG-74, "Removal and Installation \(Battery Tray\)"](#).
7. Disconnect radiator hose (upper) from radiator.
8. Disconnect the harness connectors from the fan motor.
9. Remove fan shroud and motor assembly.

## INSTALLATION

Installation is in the reverse order of removal.

- After installation refill engine coolant and check for leaks. Refer to [CO-36, "Changing Engine Coolant"](#) and [CO-35, "System Inspection"](#).

### **CAUTION:**

- **Do not spill coolant in engine compartment. Use a shop cloth to absorb coolant.**
- Cooling fans are controlled by ECM. Refer to [EC-598, "On Board Diagnosis Function"](#).

# WATER PUMP

< REMOVAL AND INSTALLATION >

[VQ35DE]

## WATER PUMP

### Exploded View

INFOID:000000009460420

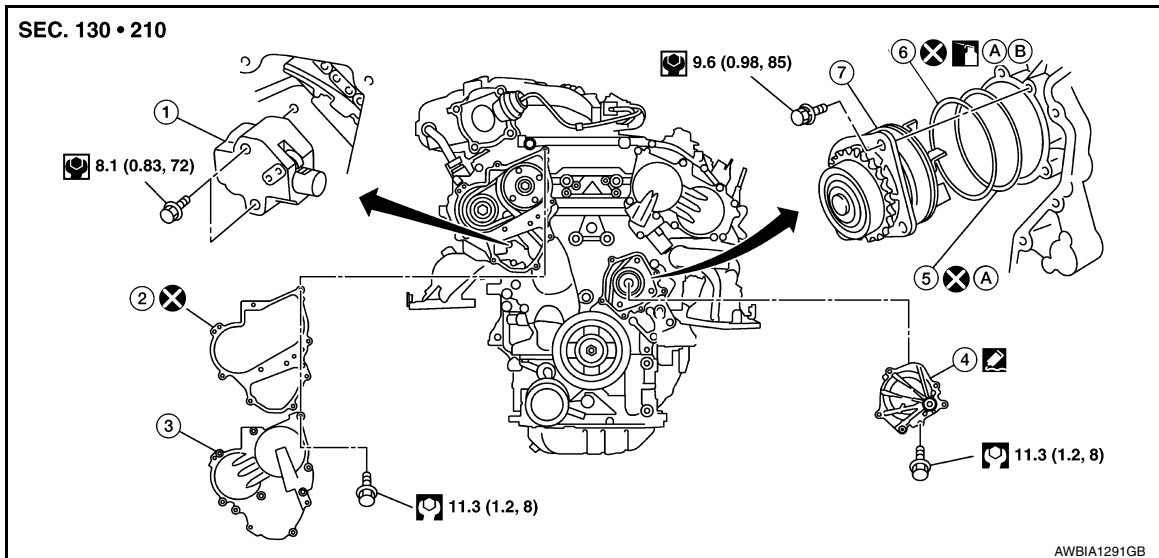

- |                                     |   |  |
|-------------------------------------|---|--|
| 1. Timing chain tensioner (primary) | 2. Valve timing control cover gasket (bank 1) | 3. Valve timing control cover (bank 1) |
| 4. Water pump cover                 | 5. O-ring                                     | 6. O-ring                              |
| 7. Water pump                       | A. Engine oil                                 | B. Identify with white mark            |

### Removal and Installation

INFOID:000000009460421

#### WARNING:

Do not remove the radiator cap when the engine is hot. Serious burns could occur from high-pressure engine coolant escaping from the radiator. Wrap a thick cloth around the cap. Slowly push down and turn it a quarter turn to allow built-up pressure to escape. Carefully remove the cap by pushing it down and turning it all the way.

#### CAUTION:

- When removing water pump assembly, be careful not to get coolant on drive belt.
- Water pump cannot be disassembled and must be replaced as a unit.
- After installing the water pump, connect hose and clamp securely, then check for leaks. Repair as necessary.

#### NOTE:

When removing components such as hoses, tubes/lines, etc., cap or plug openings to prevent fluid from spilling.

#### REMOVAL

1. Disconnect the negative battery terminal. Refer to [PG-73. "Removal and Installation \(Battery\)"](#).
2. Remove the core support cover clips (A), then remove the core support cover (1).

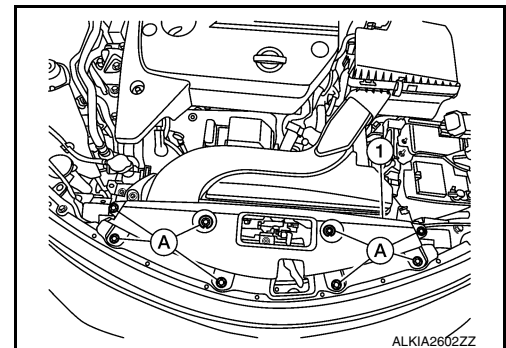

3. Remove front air duct. Refer to [EM-84. "Removal and Installation"](#).

# WATER PUMP

[VQ35DE]

## < REMOVAL AND INSTALLATION >

4. Remove cowl top extension. Refer to [EXT-24, "Removal and Installation"](#).
5. Remove the front road wheel and tire (RH). Refer to [WT-55, "Adjustment"](#).
6. Remove the fender protector (RH). Refer to [EXT-26, "FENDER PROTECTOR : Removal and Installation"](#).
7. Drain coolant from the radiator. Refer to [CO-36, "Changing Engine Coolant"](#).

**CAUTION:**

**Perform when the engine is cold.**

8. Disconnect coolant reservoir hose and remove coolant reservoir tank. Refer to [CO-40, "Exploded View"](#).
9. Drain the power steering fluid reservoir. Refer to [ST-30, "Draining and Refilling"](#).
10. Remove the power steering oil pump. Refer to [ST-38, "Removal and Installation"](#).
11. Support engine and remove the RH engine insulator and bracket. Refer to [EM-220, "Exploded View"](#).
12. Set No. 1 cylinder at TDC on its compression stroke.
  - Align pointer with TDC mark on crankshaft pulley.
13. Remove drive belt. Refer to [EM-134, "Removal and Installation"](#).
14. Remove the drive belt auto-tensioner assembly. Refer to [EM-135, "Removal and Installation of Drive Belt Auto-tensioner"](#).
15. Remove water drain plug (A) and copper sealing washer (B) to drain coolant from engine.

**CAUTION:**

**Do not reuse copper sealing washers.**

← : Front

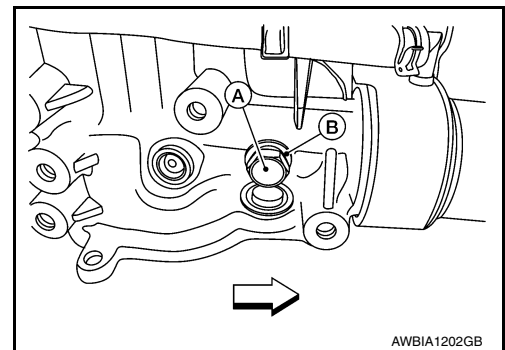

16. Disconnect RH valve timing control connectors and remove valve timing control cover (bank 1). Refer to [EM-182, "Exploded View"](#).
17. Remove water pump cover. Refer to [CO-44, "Exploded View"](#).

18. Remove the timing chain tensioner (primary) as follows:
  - a. Pull the lever (C) down to release the plunger stopper tab (B).
  - b. Insert the stopper pin A into the tensioner body hole to hold the lever (C) and keep the plunger stopper tab (B) released.

**NOTE:**

An allen wrench [(1.2 mm (0.047 in))] is used for a stopper pin A as an example.

- c. Compress the plunger (D) into the tensioner body (1) by pressing the slack guide (2).
- d. Keep the slack guide (2) pressed and lock the plunger (D) in by pushing the stopper pin A through the lever (C) and into the chain tensioner body hole.
- e. Remove timing chain tensioner bolts and then remove the timing chain tensioner.

**CAUTION:**

**Be careful not to drop timing chain tensioner bolts inside timing chain case.**

19. Remove the three water pump bolts (A). Make a gap between water pump sprocket (1) and timing chain, by carefully turning crankshaft pulley (2) counterclockwise until timing chain loosens on water pump sprocket (1).

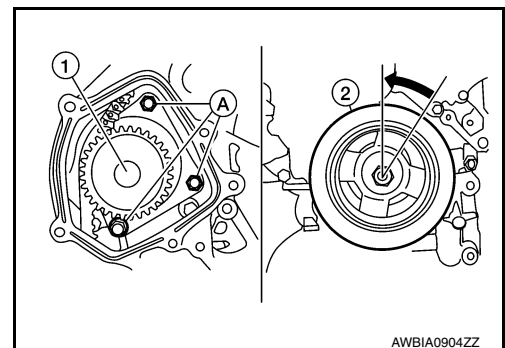
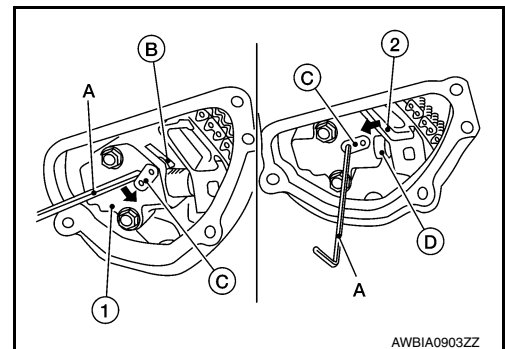

# WATER PUMP

## < REMOVAL AND INSTALLATION >

[VQ35DE]

### 20. Remove water pump:

- a. Screw M8 bolts approximately 50 mm (1.97 in) into water pump upper and lower bolt holes until they reach the timing chain case [M8 bolt pitch 1.25 mm (0.49 in) length].

**CAUTION:**

- Place a suitable shop cloth below the water pump housing to prevent any coolant from dripping into the timing chain case.
- Pull water pump straight out while preventing vane from contacting socket in installation area.
- Remove water pump without causing sprocket to contact timing chain.

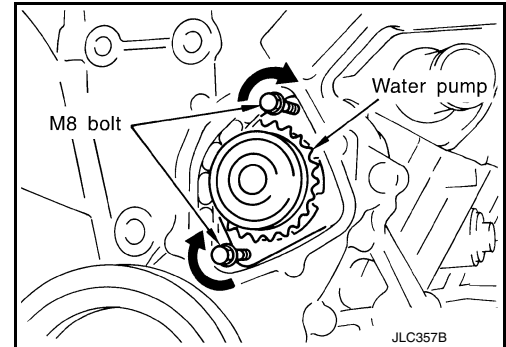

- b. Remove M8 bolts and O-rings from water pump.

**CAUTION:**

**Do not reuse O-rings.**

### INSPECTION AFTER REMOVAL

- Visually check for significant dirt or rust on the water pump body and vane.
- Check that the vane shaft turns smoothly by hand and is not excessively loose.
- Replace the water pump assembly if the water pump does not perform properly.

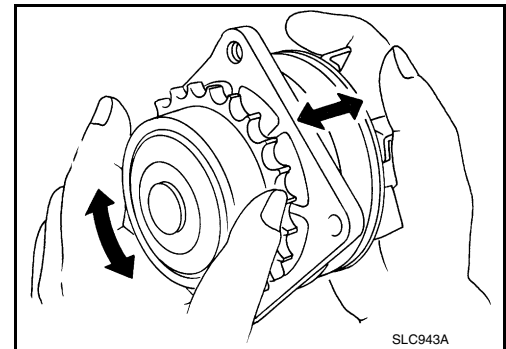

### INSTALLATION

1. Install new O-rings on water pump (1).

**CAUTION:**

**Do not reuse O-rings.**

- a. Apply engine oil to the O-rings (2,3) as shown.
- b. Locate the O-ring (2) with white paint mark (A) to engine front side.

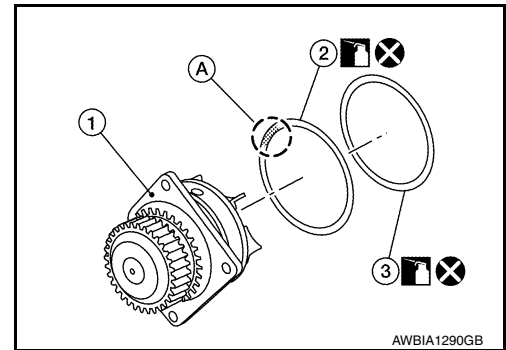

2. Hold timing chain to the side (←) and install the water pump (←).

**CAUTION:**

**Do not allow the O-rings to be damaged by the cylinder block when installing the water pump.**

- Check that timing chain and water pump sprocket are engaged.
- Tighten water pump bolts alternately and evenly to specification.

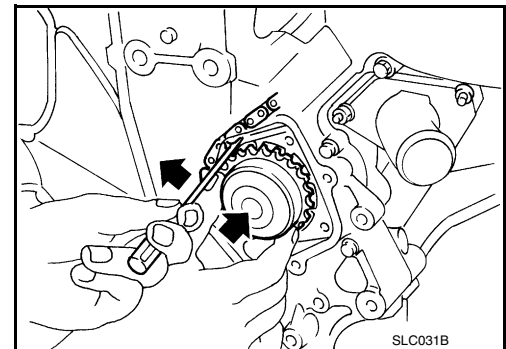

3. Remove dust and foreign material completely from installation area of timing chain tensioner and rear timing chain case.

# WATER PUMP

[VQ35DE]

## < REMOVAL AND INSTALLATION >

- Turn the crankshaft pulley approximately 20° clockwise so that the timing chain on the timing chain tensioner side is loose.

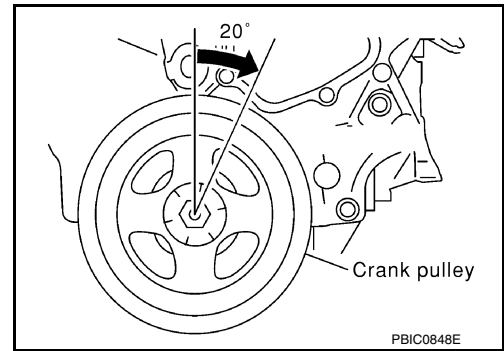

- Apply engine oil to the oil feed hole and timing chain tensioner and install the timing chain tensioner.
- Remove the stopper pin (A).

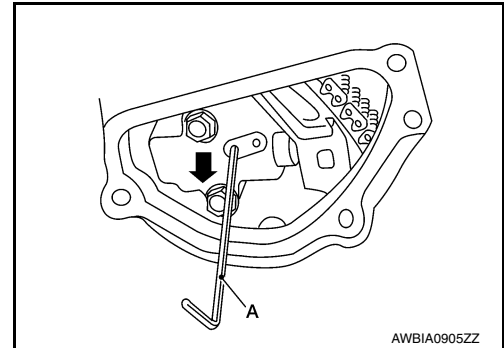

- Install valve timing control cover (bank 1) and water pump cover.
  - Before installing, remove all traces of liquid gasket from mating surface of water pump cover and IVT cover using a scraper. Also remove traces of liquid gasket from the mating surface of the front cover.
  - Apply a continuous bead of liquid gasket to mating surface of IVT cover and water pump cover. **Use Genuine RTV Silicone Sealant or equivalent. Refer to [GI-21, "Recommended Chemical Products and Sealants"](#).**

### CAUTION:

- Installation should be done within 5 minutes after applying liquid gasket.
- Do not fill the engine with oil for at least 30 minutes after the components are installed to allow the sealant to cure.

- Install water drain plug (A) and copper sealing washer (B).

### CAUTION:

Do not reuse copper sealing washers.

← : Front

Water drain plug (A) : Refer to [EM-224, "Disassembly and Assembly"](#).

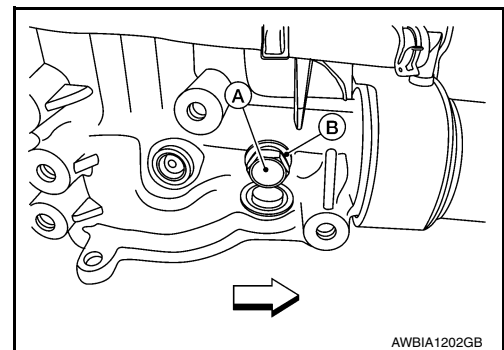

- Installation of remaining components is in the reverse order of removal.
  - After installation, refill coolant and check for leaks. Refer to [CO-36, "Changing Engine Coolant"](#) and [CO-35, "System Inspection"](#).

### CAUTION:

Do not spill coolant in engine compartment. Use a shop cloth to absorb coolant.

- After starting engine, let idle for three minutes, then rev engine up to 3,000 rpm under no load to purge air from the high-pressure chamber of the chain tensioner. The engine may produce a rattling noise. This indicates that air still remains in the chamber and is not a matter of concern.

## INSPECTION AFTER INSTALLATION

- Before starting engine, check oil/fluid levels including engine coolant and engine oil. If less than required quantity, fill to the specified level. Refer to [MA-11, "FOR USA AND CANADA : Fluids and Lubricants"](#).

# WATER PUMP

## < REMOVAL AND INSTALLATION >

[VQ35DE]

- Use procedure below to check for fuel leakage.
- Turn ignition switch ON (with engine stopped). With fuel pressure applied to fuel piping, check for fuel leakage at connection points.
- Start engine. With engine speed increased, check again for fuel leakage at connection points.
- Run engine to check for unusual noise and vibration.

**NOTE:**

If hydraulic pressure inside timing chain tensioner drops after removal and installation, slack in the guide may generate a pounding noise during and just after engine start. However, this is normal. Noise will stop after hydraulic pressure rises.

- Warm up engine thoroughly to make sure there is no leakage of fuel, exhaust gas, or any oils/fluids including engine oil and engine coolant.
- Bleed air from passages in lines and hoses, such as in cooling system.
- After cooling down engine, again check oil/fluid levels including engine oil and engine coolant. Refill to specified level, if necessary.
- Summary of the inspection items:

Item		Before starting engine	Engine running	After engine stopped
Engine coolant		Level	Leakage	Level
Engine oil		Level	Leakage	Level
Transmission/ transaxle fluid	CVT Models	Leakage	Level/Leakage	Leakage
Other oils and fluids*		Level	Leakage	Level
Fuel		Leakage	Leakage	Leakage
Exhaust gas		—	Leakage	—

\*Power steering fluid, brake fluid, etc.



# THERMOSTAT AND THERMOSTAT HOUSING

< REMOVAL AND INSTALLATION >

[VQ35DE]

## THERMOSTAT AND THERMOSTAT HOUSING

Exploded View

INFOID:000000009460422

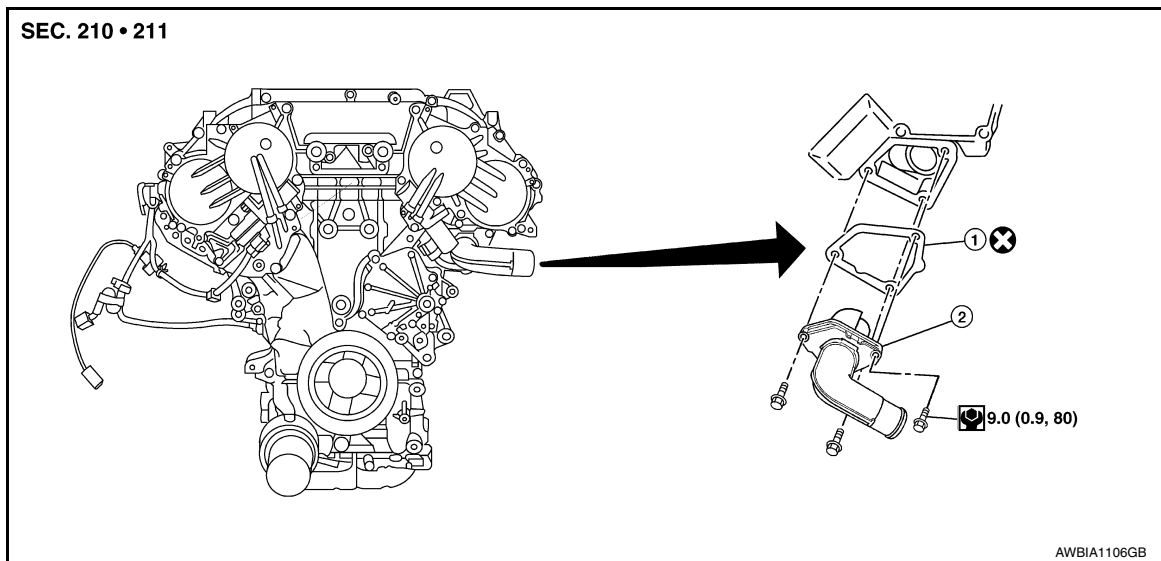

1. Gasket
2. Thermostat assembly

### WARNING:

Do not remove the radiator cap when the engine is hot. Serious burns could occur from high-pressure engine coolant escaping from the radiator. Wrap a thick cloth around the cap. Slowly push down and turn it a quarter turn to allow built-up pressure to escape. Carefully remove the cap by pushing it down and turning it all the way.

### NOTE:

When removing components such as hoses, tubes/lines, etc., cap or plug openings to prevent fluid from spilling.

## Removal and Installation

INFOID:000000009460423

### REMOVAL

1. Drain engine coolant from the radiator. Refer to [CO-36. "Changing Engine Coolant"](#).

### CAUTION:

Perform when engine is cool.

2. Remove the core support cover clips (A), then remove the core support cover (1).

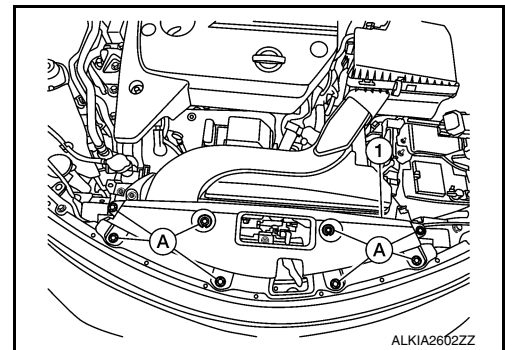

3. Remove front air duct. Refer to [EM-144. "Removal and Installation"](#).
4. Disconnect radiator hose (lower).
5. Remove coolant reservoir hose.
6. Remove coolant reservoir tank. Refer to [CO-41. "Removal and Installation"](#).
7. Disconnect IVT control valve connector.

# THERMOSTAT AND THERMOSTAT HOUSING

[VQ35DE]

## < REMOVAL AND INSTALLATION >

8. Remove engine coolant inlet, thermostat assembly and gasket.
- Do not disassemble engine coolant inlet and thermostat. Replace them as a unit, if necessary.
  - Do not reuse gasket.

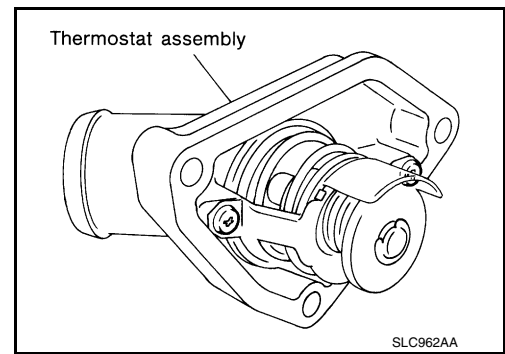

## INSPECTION AFTER REMOVAL

- Place a thread so that it is caught in the valves of the thermostat. Immerse fully in a container filled with water. Heat while stirring.
- The valve opening temperature is the temperature at which the valve opens and the thermostat falls from the thread.
- Continue heating. Check the full-open lift amount.

### NOTE:

The full-open lift amount standard temperature for the thermostat is the reference value.

- After checking the full-open lift amount, lower the water temperature and check the valve closing temperature.

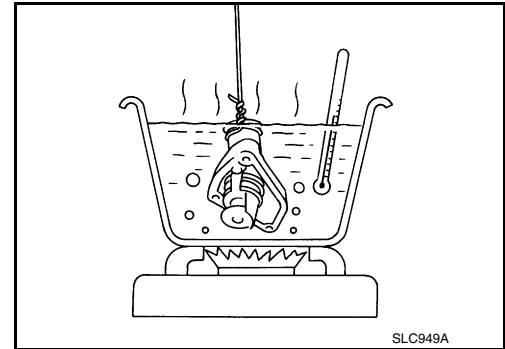

Thermostat	Standard Values
Valve opening temperature	Refer to <a href="#">CO-53. "Thermostat"</a>
Full-open lift amount	Refer to <a href="#">CO-53. "Thermostat"</a>
Valve closing temperature	Refer to <a href="#">CO-53. "Thermostat"</a>

- If valve setting at measured values are out of standard range, replace thermostat.

## INSTALLATION

Installation is in the reverse order of removal.

- Install thermostat with jiggle valve facing upward.
- After installation refill engine coolant and check for leaks. Refer to [CO-36. "Changing Engine Coolant"](#) and [CO-35. "System Inspection"](#).

### CAUTION:

- Do not spill coolant in engine compartment. Use a shop cloth to absorb coolant.
- Do not reuse gasket.

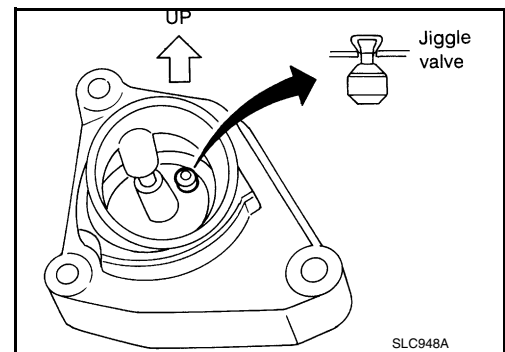

# WATER OUTLET AND WATER PIPING

< REMOVAL AND INSTALLATION >

[VQ35DE]

## WATER OUTLET AND WATER PIPING

Exploded View

INFOID:000000009460424

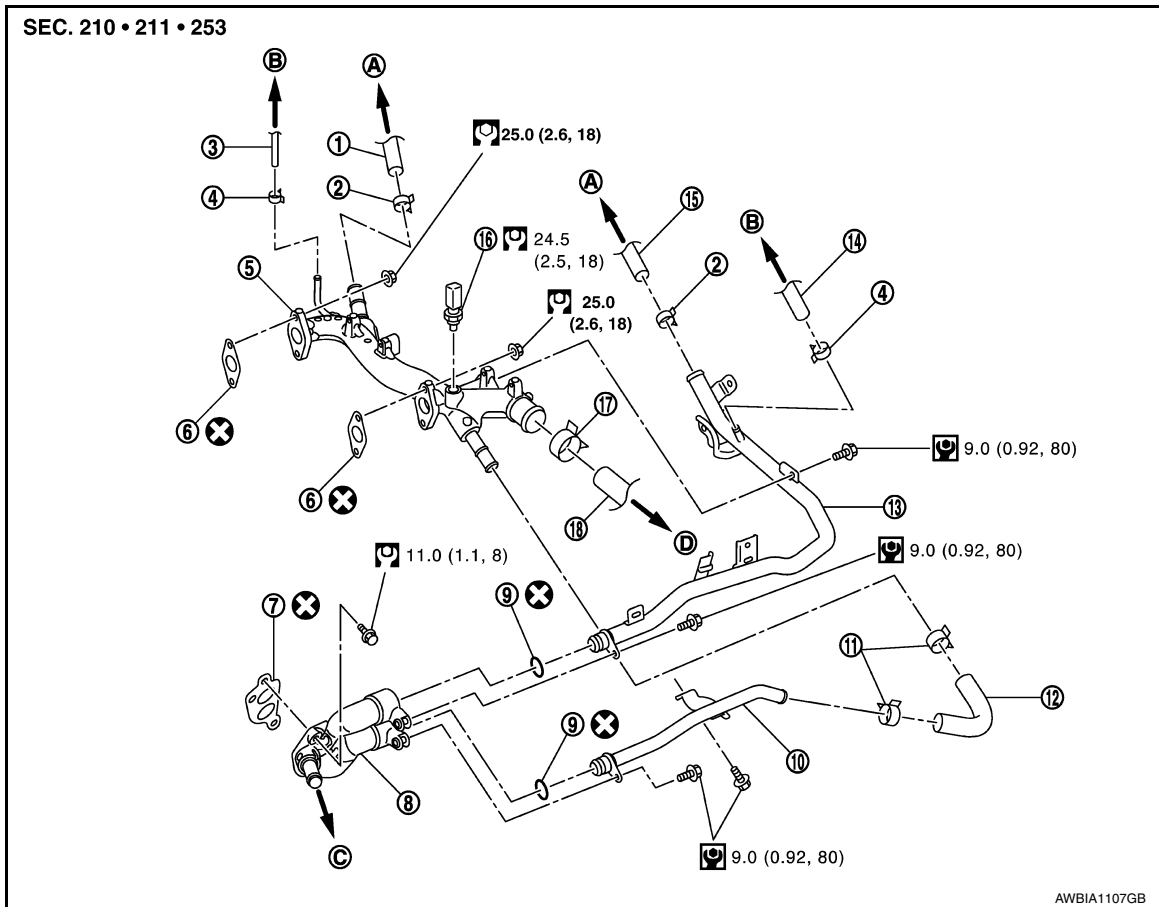

- |                                       |  |                           |
|---------------------------------------|--|---------------------------|
| 1. Heater hose                        | 2. Clamp                                 | 3. Water hose             |
| 4. Clamp                              | 5. Water outlet                          | 6. Gasket                 |
| 7. Gasket                             | 8. Water connector                       | 9. O-ring                 |
| 10. Water bypass pipe                 | 11. Clamp                                | 12. Water hose            |
| 13. Heater pipe                       | 14. Water hose                           | 15. Heater hose           |
| 16. Engine coolant temperature sensor | 17. Clamp                                | 18. Radiator hose (upper) |
| A. To heater core                     | B. To electric throttle control actuator | C. To oil cooler          |
| D. To radiator                        |  |                           |

### WARNING:

Do not remove the radiator cap when the engine is hot. Serious burns could occur from high-pressure engine coolant escaping from the radiator. Wrap a thick cloth around the cap. Slowly push down and turn it a quarter turn to allow built-up pressure to escape. Carefully remove the cap by pushing it down and turning it all the way.

### NOTE:

When removing components such as hoses, tubes/lines, etc., cap or plug openings to prevent fluid from spilling.

## Removal and Installation

INFOID:000000009460425

### REMOVAL

1. Remove engine room cover. Refer to [EM-28, "Removal and Installation"](#).

### CAUTION:

Perform when the engine is cold.

## WATER OUTLET AND WATER PIPING

[VQ35DE]

### < REMOVAL AND INSTALLATION >

- Partially drain engine coolant from radiator. Refer to [CO-36. "Changing Engine Coolant"](#).
- Remove the core support cover clips (A), then remove the core support cover (1).

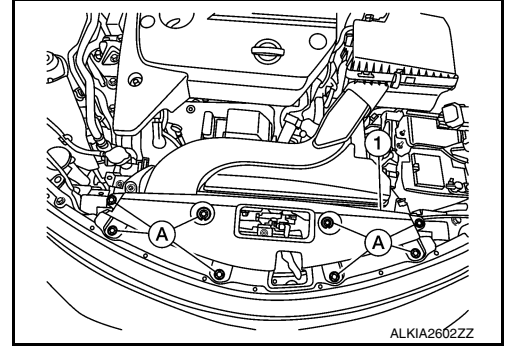

- Remove front air duct. Refer to [EM-84. "Removal and Installation"](#).
- Remove air duct and air cleaner case assembly. Refer to [EM-144. "Removal and Installation"](#).
- Remove engine side under cover (RH). Refer to [EXT-28. "Removal and Installation"](#).
- Disconnect hoses from electric throttle control actuator.
- Remove radiator upper hose and heater hoses.
- Remove connector(s) from heater pipe.
- Disconnect engine coolant temperature sensor electrical connector on water outlet.
- Remove water outlet, heater pipe, water connector, and water bypass pipe nuts and bolts.
- Remove engine coolant temperature sensor, if necessary.

### INSTALLATION

Installation is in the reverse order of removal.

- Securely insert each hose, and install a clamp at a position where it does not interfere with the pipe bulge.
- When inserting heater pipe and water bypass pipe into water connector, apply mild soap to new O-rings.

#### **CAUTION:**

#### **Do not reuse O-ring.**

- After installation refill engine coolant and check for leaks. Refer to [CO-36. "Changing Engine Coolant"](#) and [CO-35. "System Inspection"](#).

# SERVICE DATA AND SPECIFICATIONS (SDS)

< SERVICE DATA AND SPECIFICATIONS (SDS)

[VQ35DE]

## SERVICE DATA AND SPECIFICATIONS (SDS)

### SERVICE DATA AND SPECIFICATIONS (SDS)

#### Capacity

INFOID:000000009460426

ℓ (US qt, Imp qt)

Coolant capacity (With reservoir tank at MAX level)	9.2 (9-3/4, 8-1/8)
---	--------------------

#### Thermostat

INFOID:000000009460427

Valve opening temperature	82°C (180°F)
Full-open lift amount	8.6 mm / 95°C (0.339 in / 203°F)
Valve closing temperature	77°C (171°F)

#### Radiator

INFOID:000000009460428

Unit: kPa (kg/cm<sup>2</sup>, psi)

Cap relief pressure	Standard	127 ± 9.8 (1.30 ± 0.10, 18.4 ± 1.42)
Testing pressure		156 (1.6, 23)

A  
CO  
C  
D  
E  
F  
G  
H  
I  
J  
K  
L  
M  
N  
O  
P