

SECTION **RSU**  
 REAR SUSPENSION

A  
 B  
 C  
 D  
 E  
 F  
 G  
 H  
 I  
 J  
 K  
 L  
 M  
 N  
 O  
 P

RSU

CONTENTS

<b>PRECAUTION</b> .....	2	<b>SHOCK ABSORBER</b> .....	9
<b>PRECAUTIONS</b> .....	2	Exploded View .....	9
Precaution for Supplemental Restraint System (SRS) "AIR BAG" and "SEAT BELT PRE-TENSIONER" .....	2	Removal and Installation .....	9
General Precautions .....	2	Disassembly and Assembly .....	10
<b>PREPARATION</b> .....	3	Disposal .....	10
<b>PREPARATION</b> .....	3	<b>REAR STABILIZER</b> .....	11
Special Service Tools .....	3	Exploded View .....	11
Commercial Service Tool .....	3	Removal and Installation .....	11
<b>SYMPTOM DIAGNOSIS</b> .....	4	<b>SUSPENSION ARM</b> .....	12
<b>NOISE, VIBRATION AND HARSHNESS (NVH) TROUBLESHOOTING</b> .....	4	Exploded View .....	12
NVH Troubleshooting Chart .....	4	Removal and Installation .....	12
<b>PERIODIC MAINTENANCE</b> .....	5	<b>UNIT REMOVAL AND INSTALLATION</b> .....	13
<b>REAR SUSPENSION ASSEMBLY</b> .....	5	<b>REAR SUSPENSION ASSEMBLY</b> .....	13
On-vehicle Service .....	5	Exploded View .....	13
Inspection .....	5	Removal and Installation .....	13
Inspection and Adjustment .....	5	<b>SERVICE DATA AND SPECIFICATIONS (SDS)</b> .....	17
<b>REMOVAL AND INSTALLATION</b> .....	8	<b>SERVICE DATA AND SPECIFICATIONS (SDS)</b> .....	17
<b>REAR LOWER LINK &amp; COIL SPRING</b> .....	8	General Specification (Rear) .....	17
Removal and Installation .....	8	Wheel Alignment (Unladen*) .....	17
		Wheelarch Height (Unladen* <sup>1</sup> ) .....	17

# PRECAUTIONS

< PRECAUTION >

## PRECAUTION

### PRECAUTIONS

#### Precaution for Supplemental Restraint System (SRS) "AIR BAG" and "SEAT BELT PRE-TENSIONER"

INFOID:000000012601389

The Supplemental Restraint System such as "AIR BAG" and "SEAT BELT PRE-TENSIONER", used along with a front seat belt, helps to reduce the risk or severity of injury to the driver and front passenger for certain types of collision. Information necessary to service the system safely is included in the SR and SB section of this Service Manual.

#### **WARNING:**

- To avoid rendering the SRS inoperative, which could increase the risk of personal injury or death in the event of a collision which would result in air bag inflation, it is recommended that all maintenance and repair be performed by an authorized NISSAN/INFINITI dealer.
- Improper repair, including incorrect removal and installation of the SRS, can lead to personal injury caused by unintentional activation of the system. For removal of Spiral Cable and Air Bag Module, see the SR section.
- Do not use electrical test equipment on any circuit related to the SRS unless instructed to in this Service Manual. SRS wiring harnesses can be identified by yellow and/or orange harnesses or harness connectors.

#### PRECAUTIONS WHEN USING POWER TOOLS (AIR OR ELECTRIC) AND HAMMERS

#### **WARNING:**

- When working near the Airbag Diagnosis Sensor Unit or other Airbag System sensors with the Ignition ON or engine running, DO NOT use air or electric power tools or strike near the sensor(s) with a hammer. Heavy vibration could activate the sensor(s) and deploy the air bag(s), possibly causing serious injury.
- When using air or electric power tools or hammers, always switch the Ignition OFF, disconnect the battery or batteries, and wait at least three minutes before performing any service.

#### General Precautions

INFOID:000000012601390

- When installing rubber bushings, the final tightening must be carried out under unladen conditions with tires on ground. Oil might shorten the life of rubber bushings. Be sure to wipe off any spilled oil.
- Unladen conditions mean that fuel, engine coolant and lubricants are full. Spare tire, jack, hand tools and mats are in designated positions.
- After servicing suspension parts, be sure to check wheel alignment.
- Self-lock nuts are not reusable. Always use new ones when installing. Since new self-lock nuts are pre-oiled, tighten as they are.

# PREPARATION

< PREPARATION >

## PREPARATION

### PREPARATION

#### Special Service Tools

INFOID:000000012601391

The actual shape of the tools may differ from those illustrated here.

Tool number (TechMate No.) Tool name	Description
— (J-49286) Drift and pull gauge	Measuring drift and pull

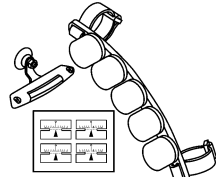

AWEIA0156ZZ

A  
B  
C  
D  
RSU

#### Commercial Service Tool

INFOID:000000012601392

Tool name	Description
Power tool	Loosening nuts, screws and bolts



PIIB1407E

F  
G  
H  
I  
J  
K  
L  
M  
N  
O  
P

# NOISE, VIBRATION AND HARSHNESS (NVH) TROUBLESHOOTING

< SYMPTOM DIAGNOSIS >

## SYMPTOM DIAGNOSIS

### NOISE, VIBRATION AND HARSHNESS (NVH) TROUBLESHOOTING

#### NVH Troubleshooting Chart

INFOID:000000012601393

Use the chart below to help you find the cause of the symptom. If necessary, repair or replace these parts.

Reference page		RSU-13	—	—	—	—	RSU-13	RSU-5	—	FAX-5	FSU-5	WT-51	WT-51	FAX-5	BR-6	ST-30	
Possible cause and SUSPECTED PARTS		Improper installation, looseness	Shock absorber deformation, damage or deflection	Bushing or mounting deterioration	Parts interference	Spring fatigue	Suspension looseness	Incorrect wheel alignment	Stabilizer bar fatigue	FRONT AXLE	FRONT SUSPENSION	TIRES	WHEEL	DRIVE SHAFT	BRAKES	STEERING	
Symptom	REAR SUSPENSION	Noise	x	x	x	x	x			x	x	x	x	x	x	x	
		Shake	x	x	x	x		x		x	x	x	x	x	x	x	
		Vibration	x	x	x	x	x				x	x		x			x
		Shimmy	x	x	x	x			x		x	x	x	x		x	x
		Shudder	x	x	x						x	x	x	x		x	x
		Poor quality ride or handling	x	x	x	x	x		x	x	x	x	x	x			

x: Applicable

# REAR SUSPENSION ASSEMBLY

< PERIODIC MAINTENANCE >

## PERIODIC MAINTENANCE

### REAR SUSPENSION ASSEMBLY

#### On-vehicle Service

INFOID:0000000012601394

- Check the suspension parts for excessive play, cracks, wear or damage. Shake each rear wheel to check for excessive play.
- Retighten all nuts and bolts to the specified torque.
- Check the shock absorber for oil leakage or other damage.
- Check the wheelarch height. Refer to [RSU-17. "Wheelarch Height \(Unladen\\*1\)".](#)

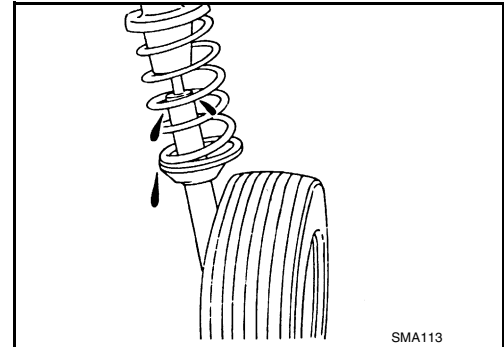

#### Inspection

INFOID:0000000012601395

##### SHOCK ABSORBER ASSEMBLY

- Check for smooth operation through a full stroke for both compression and extension.
- Check for oil leakage on the welded or gland packing portions.
- Check the shock absorber piston rod for cracks, deformation, or other damage and replace if necessary.

##### SUSPENSION ARMS

- Check the suspension arm for damage, cracks, deformation and replace if necessary.
- Check the rubber bushings for damage, cracks and deformation. Replace suspension arm if necessary.
- After installing the radius rod, check the wheel alignment and adjust if necessary. Refer to [RSU-17. "Wheel Alignment \(Unladen\\*\)".](#)

##### FRONT LOWER LINK

- Check the front lower link for any deformation, cracks, or damage and replace if necessary.

##### UPPER AND LOWER RUBBER SEATS

- Check the upper and lower rubber seats for deterioration, or cracks and replace if necessary.

##### REAR LOWER LINK AND COIL SPRING

- Check the rear lower link and coil spring for any deformation, cracks, or other damage and replace if necessary.

##### STABILIZER BAR

- Check the stabilizer bar and clamps for any deformation, cracks, or damage and replace if necessary.
- Check the rubber bushings for deterioration, or cracks and replace if necessary.

#### Inspection and Adjustment

INFOID:0000000012601396

Before checking the rear wheel alignment, make a preliminary inspection.

- Measure the wheel alignment under unladen conditions.

##### NOTE:

Unladen conditions mean that fuel, engine coolant, and lubricants are full. That the spare tire, jack, hand tools, and mats are in their designated positions.

##### PRELIMINARY INSPECTION

- Check the tires for wear and for improper inflation.
- Check the wheels for deformation, cracks, and other damage. Remove the wheel and check the wheel runout. Refer to [WT-52. "Inspection".](#)
- Check the rear wheel bearings for looseness.
- Check the rear suspension for looseness.
- Check that the rear shock absorbers work properly.

# REAR SUSPENSION ASSEMBLY

## < PERIODIC MAINTENANCE >

- Check the wheelarch height in the unladen condition. Refer to [RSU-17, "Wheelarch Height \(Unladen\\*1\)"](#).

## GENERAL INFORMATION AND RECOMMENDATIONS

1. A Four-Wheel Thrust Alignment should be performed.
  - This type of alignment is recommended for any NISSAN vehicle.
  - The four-wheel "thrust" process helps ensure that the vehicle is properly aligned and the steering wheel is centered.
  - The alignment machine itself should be capable of accepting any NISSAN vehicle.
  - The alignment machine should be checked to ensure that it is level.
2. Make sure the alignment machine is properly calibrated.
  - Your alignment machine should be regularly calibrated in order to give correct information.
  - Check with the manufacturer of your specific alignment machine for their recommended Service/Calibration Schedule.

## THE ALIGNMENT PROCESS

**IMPORTANT:** Use only the alignment specifications listed in this Service Manual. Refer to [RSU-17, "Wheelarch Height \(Unladen\\*1\)"](#).

1. When displaying the alignment settings, many alignment machines use "indicators": (Green/red, plus or minus, Go/No Go). **Do NOT use these indicators.**
  - The alignment specifications programmed into your alignment machine that operate these indicators may not be correct.
  - This may result in an ERROR.
2. Most camera-type alignment machines are equipped with both "Rolling Compensation" method and optional "Jacking Compensation" method to "compensate" the alignment targets or head units. "Rolling Compensation" is the preferred method.
  - If using the "Rolling Compensation" method, after installing the alignment targets or head units, push or pull on the rear wheel to move the vehicle. Do not push or pull the vehicle body.
  - If using the "Jacking Compensation" method, after installing the alignment targets or head units, raise the vehicle and rotate the wheels 1/2 turn both ways.

### **NOTE:**

- Do not use the "Rolling Compensation" method if you are using sensor-type alignment equipment.
- Follow all instructions for the alignment machine you are using for more information.

## CAMBER and TOE

- Camber and toe are both set by adjustment of the front lower link and rear lower link adjusting bolts.

1. Loosen the nuts at the adjustment points on the front lower link and rear lower link.
2. Adjust the camber and toe by turning bolt (1) on front lower link (2).

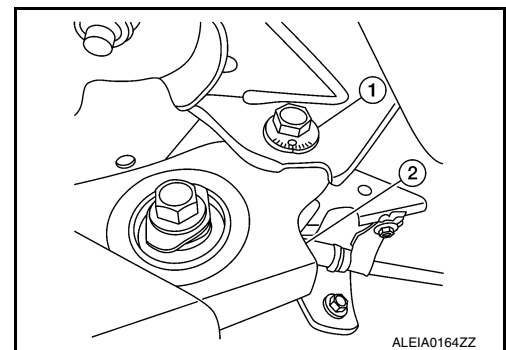

3. Adjust the camber and toe by turning bolt (1) on rear lower link (2).

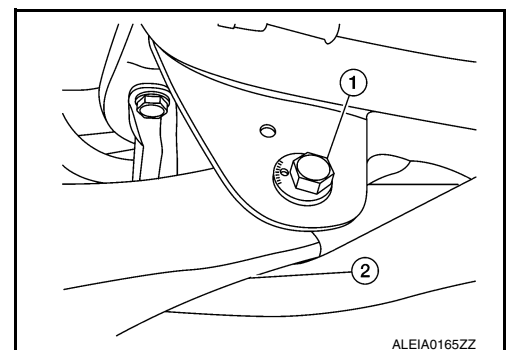

# REAR SUSPENSION ASSEMBLY

## < PERIODIC MAINTENANCE >

---

### NOTE:

- Camber changes about  $0^{\circ} 5'$  ( $0.08^{\circ}$ ) with each graduation of the adjusting bolt.
- Turn the adjusting bolts in the same direction to calibrate camber.
- Toe changes about 1.5 mm (0.059 in) [one side] with each graduation of the adjusting bolt.
- Turn the adjusting bolts in the opposite direction to calibrate toe.

**Camber** : Refer to [RSU-17, "Wheel Alignment \(Unladen\\*\)"](#).

**Total toe-in** : Refer to [RSU-17, "Wheel Alignment \(Unladen\\*\)"](#).

4. Tighten the adjusting bolt nuts to the specified torque.

**Adjusting bolt nuts** : Refer to [RSU-13, "Exploded View"](#).

A  
B  
C  
D  
F  
G  
H  
I  
J  
K  
L  
M  
N  
O  
P

RSU

## REAR LOWER LINK & COIL SPRING

< REMOVAL AND INSTALLATION >

---

### REMOVAL AND INSTALLATION

#### REAR LOWER LINK & COIL SPRING

##### Removal and Installation

INFOID:0000000012601397

##### Removal

The front and rear lower link with coil spring must be removed with the Rear Suspension Assembly. Refer to [RSU-13, "Removal and Installation"](#).



# SHOCK ABSORBER

< REMOVAL AND INSTALLATION >

## SHOCK ABSORBER

Exploded View

INFOID:000000012601398

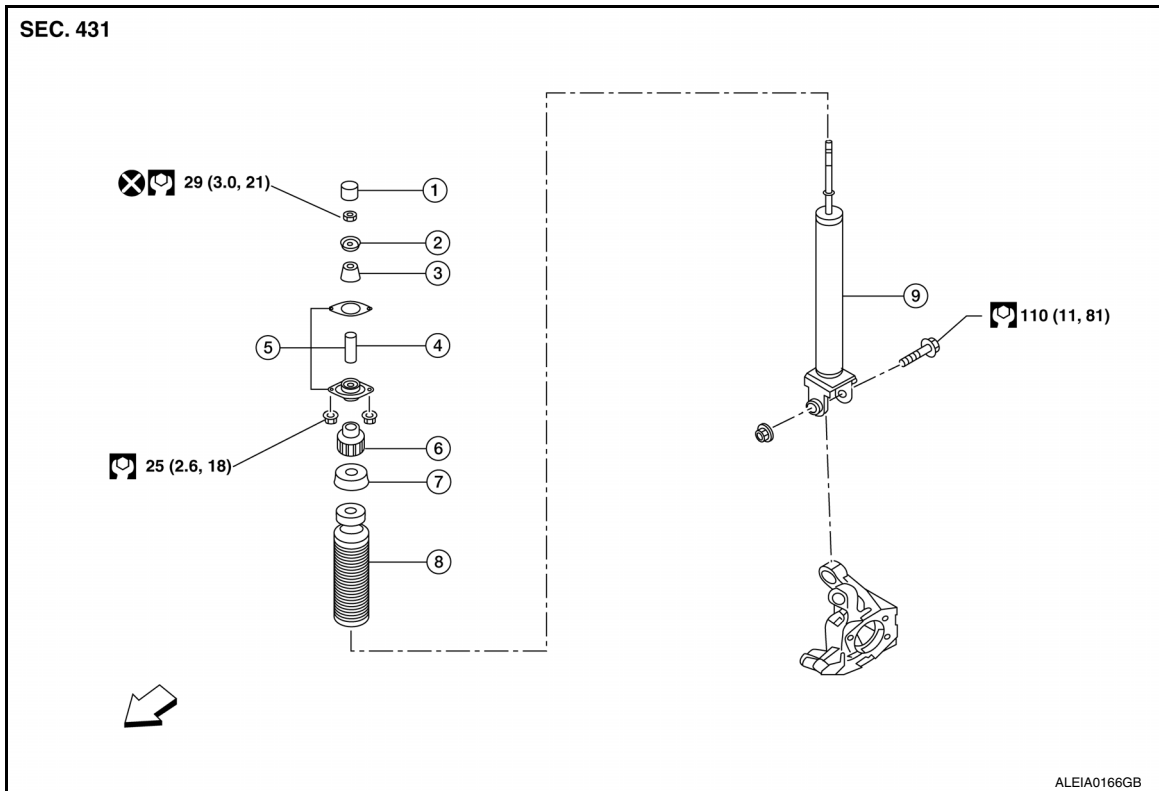

- |                       |                                 |                        |
|-----------------------|---------------------------------|------------------------|
| 1. Cap                | 2. Washer                       | 3. Upper shock bushing |
| 4. Distance tube      | 5. Shock absorber mount bracket | 6. Lower shock bushing |
| 7. Bound bumper cover | 8. Bound bumper                 | 9. Shock absorber      |

↔ Front

## Removal and Installation

INFOID:000000012601399

### REMOVAL

1. Remove rear wheel and tire using power tool. Refer to [WT-60. "Road Wheel"](#).
2. Set a jack under the rear lower link to relieve the coil spring tension.
3. Remove lower shock absorber bolt with a power tool.
4. Gradually lower the jack and separate the shock absorber from rear lower link.
5. Remove the shock absorber upper end nuts (↔) with power tool.

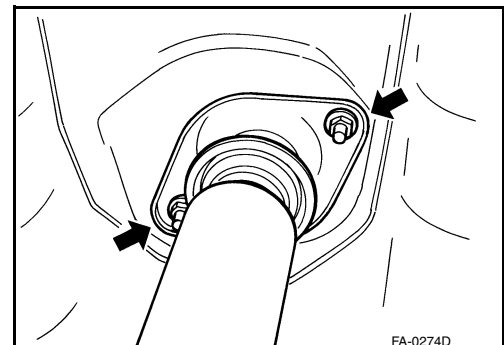

6. Remove shock absorber assembly from vehicle.

### INSTALLATION

A  
B  
C  
D  
RSU  
F  
G  
H  
I  
J  
K  
L  
M  
N  
O  
P

# SHOCK ABSORBER

## < REMOVAL AND INSTALLATION >

Installation is the reverse order of removal.

### NOTE:

Perform final tightening of shock absorber assembly lower side (rubber bushing) under unladen condition with tires on level ground.

## Disassembly and Assembly

INFOID:0000000012601400

### DISASSEMBLY

#### CAUTION:

**Do not damage piston rod when removing components from shock absorber.**

1. Remove the cap from the shock absorber mount bracket.
2. Wrap a shop cloth around the lower shock absorber bolt flange. Secure the lower shock absorber bolt flange in a vise.

#### CAUTION:

**Do not set the cylindrical part of shock absorber in a vise.**

3. Secure the piston rod tip so that piston rod does not turn, and remove piston rod lock nut.
4. Remove the washer, the upper shock bushing, the distance tube, the shock absorber mount bracket, the lower shock bushing, the bound bumper cover, and the bound bumper from the shock absorber.

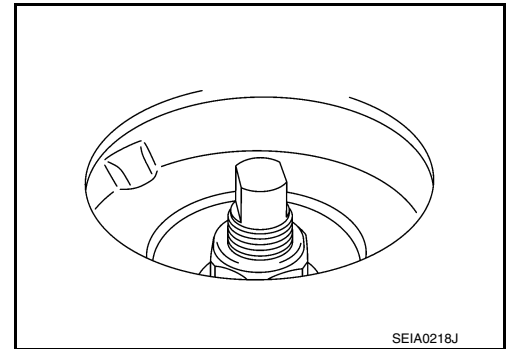

### ASSEMBLY

Installation is the reverse order of removal.

#### CAUTION:

- Do not reuse the piston rod lock nut.
- Do not damage the piston rod when installing components to the shock absorber.

## Disposal

INFOID:0000000012601401

1. Set shock absorber horizontally with the piston rod fully extended.
2. Drill 2 – 3 mm (0.08 – 0.12 in) hole at the position (●) from top as shown to release gas gradually.

#### CAUTION:

- Wear eye protection (safety glasses).
- Wear gloves.
- Be careful with metal chips or oil blown out by the compressed gas.

#### NOTE:

- Drill vertically in this direction (←) directly to the outer tube avoiding brackets.
- The gas is clear, colorless, odorless, and harmless.

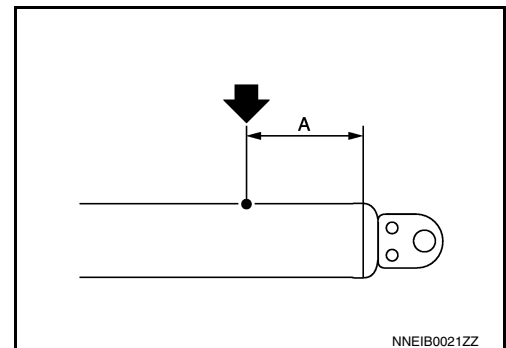

(A) : 20 – 30 mm (0.79 – 1.18 in)

3. Position the drilled hole downward and drain oil by moving the piston rod several times.

#### CAUTION:

**Dispose of drained oil according to the law and local regulations.**

# REAR STABILIZER

< REMOVAL AND INSTALLATION >

## REAR STABILIZER

### Exploded View

INFOID:000000012601402

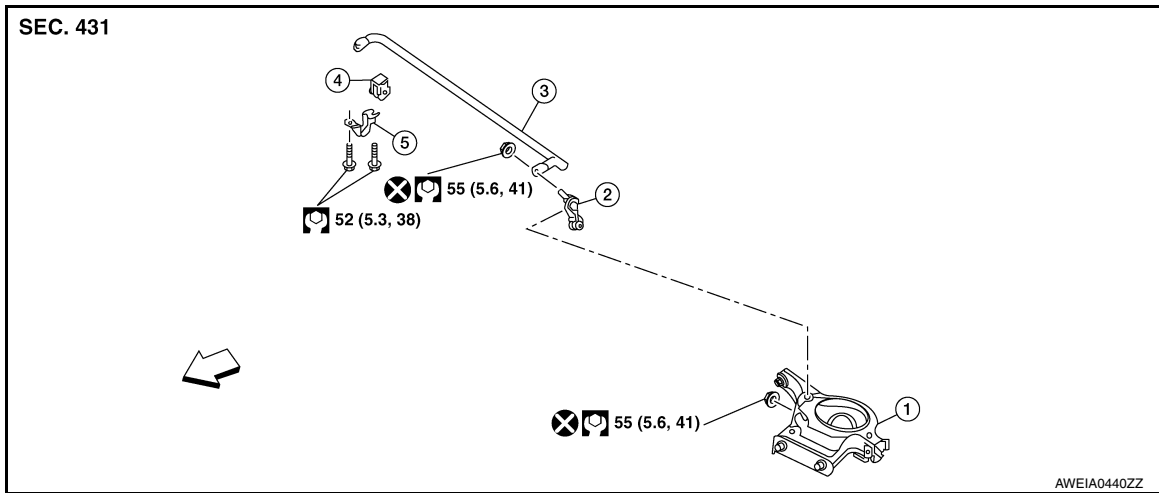

- |                           |                         |                   |
|---------------------------|-------------------------|-------------------|
| 1. Rear lower link        | 2. Connecting rod       | 3. Stabilizer bar |
| 4. Stabilizer bar bushing | 5. Stabilizer bar clamp | ← Front           |

### Removal and Installation

INFOID:000000012601403

#### Removal

1. Disconnect and remove each connecting rod from rear lower link and the stabilizer bar.
2. Remove the 4 stabilizer bar mount bracket bolts and the stabilizer bar clamps.
3. Remove the stabilizer bar bushings.
4. Remove the stabilizer bar.

#### Installation

Installation is in the reverse order of removal.

- Position the stabilizer bar bushings with the slit facing the front of the vehicle.
- While holding the stabilizer connecting rod, install the stabilizer connecting rod nuts and tighten to specification. Refer to [RSU-11, "Exploded View"](#).

#### **CAUTION:**

**Do not reuse connecting rod nuts.**



# REAR SUSPENSION ASSEMBLY

< UNIT REMOVAL AND INSTALLATION >

## UNIT REMOVAL AND INSTALLATION

### REAR SUSPENSION ASSEMBLY

Exploded View

INFOID:0000000012601406

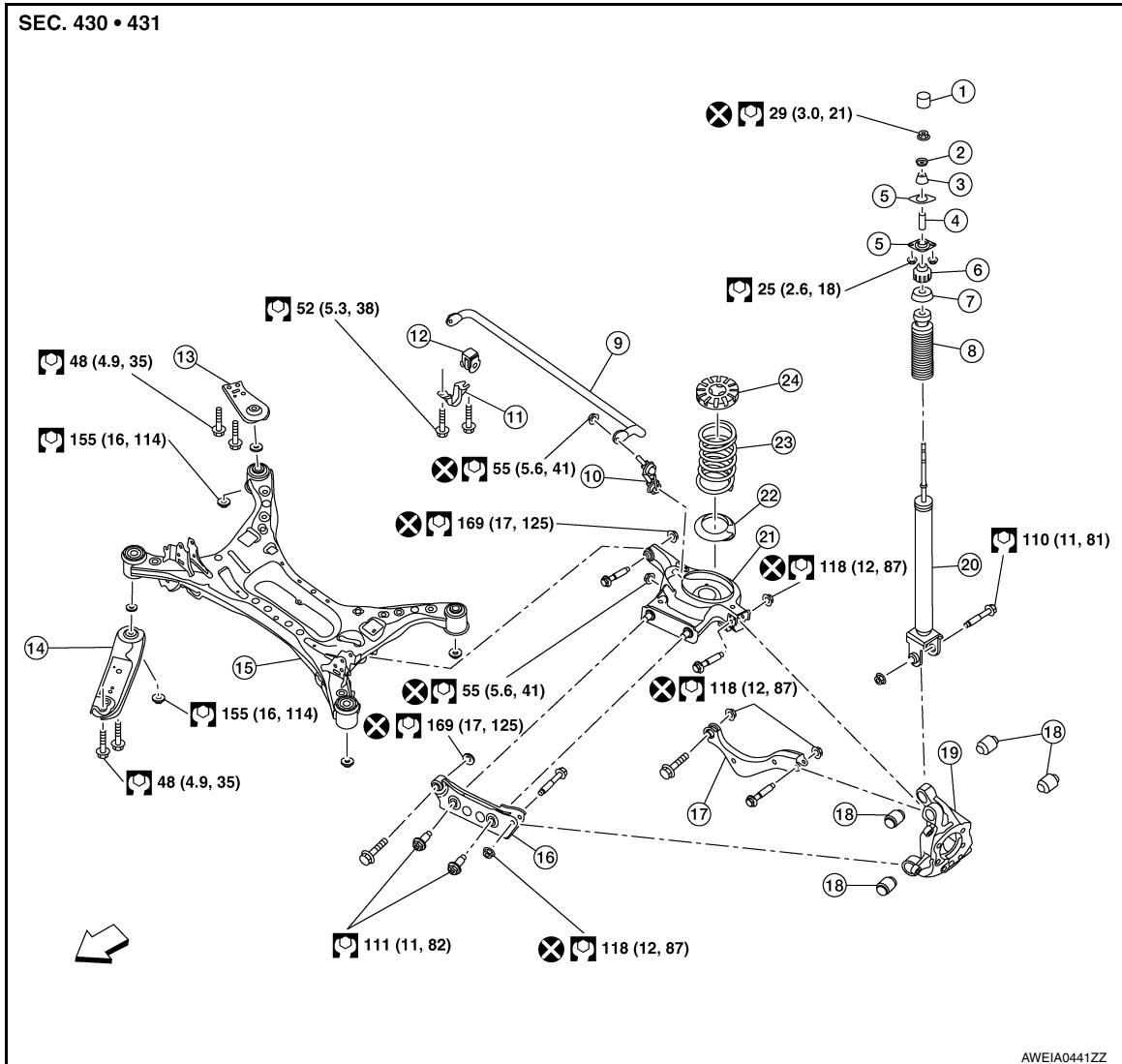

- |                       |                                 |                            |
|-----------------------|---------------------------------|----------------------------|
| 1. Cap                | 2. Washer                       | 3. Upper shock bushing     |
| 4. Distance tube      | 5. Shock absorber mount bracket | 6. Lower shock bushing     |
| 7. Bound bumper cover | 8. Bound bumper                 | 9. Stabilizer bar          |
| 10. Connecting rod    | 11. Stabilizer bar clamp        | 12. Stabilizer bar bushing |
| 13. Rear member stay  | 14. Front member stay           | 15. Rear suspension member |
| 16. Front lower link  | 17. Suspension arm              | 18. Knuckle bushing        |
| 19. Knuckle           | 20. Shock absorber              | 21. Rear lower link        |
| 22. Lower rubber seat | 23. Coil spring                 | 24. Upper rubber seat      |
- ⇐ Front

### Removal and Installation

INFOID:0000000012601407

#### Removal

1. Remove the rear wheel and tire using power tool. Refer to [WT-54, "Adjustment"](#).

A  
B  
C  
D  
RSU  
F  
G  
H  
I  
J  
K  
L  
M  
N  
O  
P

## REAR SUSPENSION ASSEMBLY

### < UNIT REMOVAL AND INSTALLATION >

- Remove the brake caliper torque member bolts, leaving the brake hose attached. Reposition the brake caliper aside with wire. Refer to [BR-43, "BRAKE CALIPER ASSEMBLY : Exploded View"](#).  
**CAUTION:**
  - Do not depress brake pedal while brake caliper assembly is removed.
  - Do not twist or stretch the brake hose.
- Put alignment marks on the disc brake rotor and rear hub and bearing assembly, then remove the disc brake rotor.
- Disconnect parking brake cables from each knuckle. Refer to [PB-9, "Exploded View"](#).
- Remove lower shock (A) absorber bolt.

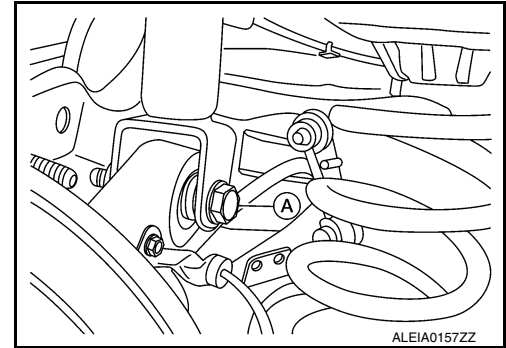

- Remove floor under covers and rear under covers (if equipped). Refer to [EXT-38, "Exploded View"](#).
- Remove the connecting rods from each rear lower link and the stabilizer bar. Refer to [RSU-11, "Exploded View"](#).
- Remove the center exhaust tube with muffler(s). Refer to [EX-5, "Exploded View"](#) (QR25DE), [EX-10, "Exploded View"](#) (VQ35DE).
- Disconnect the parking brake cables from the rear suspension member.
- Remove stabilizer bar. Refer to [RSU-11, "Removal and Installation"](#).
- Remove each rear wheel sensor from each knuckle. Refer to [BRC-166, "Removal and Installation - Rear Wheel Sensor"](#).
- Disconnect ABS harness from rear suspension member.
- Position a suitable lift table (A) to the rear suspension member and securely strap rear suspension member to lift table.

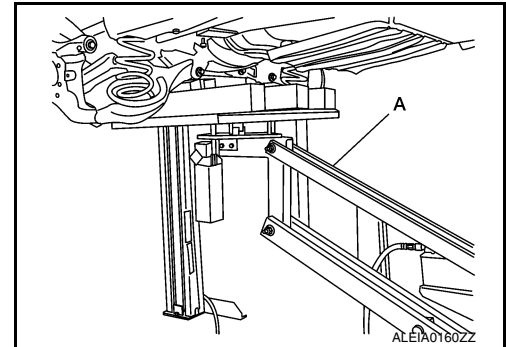

- Remove each front member stay cover, the front member stay bolts (A) and each front member stay.

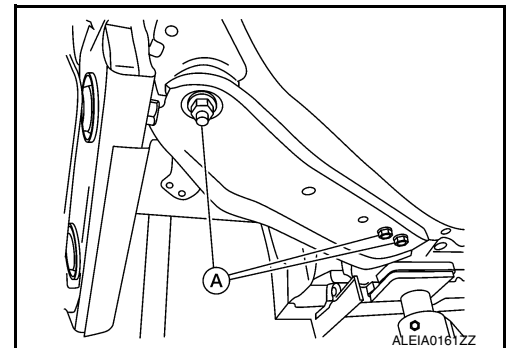

# REAR SUSPENSION ASSEMBLY

## < UNIT REMOVAL AND INSTALLATION >

15. Remove the rear member stay bolts (A) and each rear member stay.

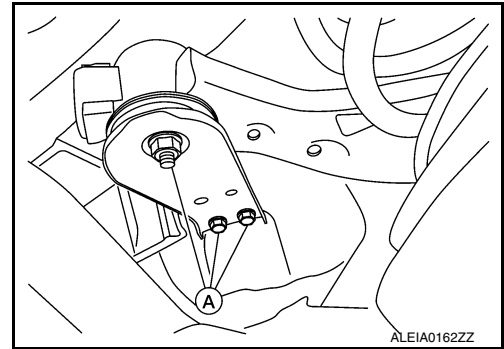

16. Remove the suspension member nuts using power tool.  
 17. Lower the rear suspension member, then remove the upper coil spring seats and the coil springs.  
 18. Remove the suspension arm bolts from the knuckles.  
 19. Remove the front and rear lower link bolts from the knuckles.  
 20. Remove each knuckle with the rear wheel hub and bearing and park brake components as an assembly.  
 21. Remove the coil spring lower rubber seat.  
 22. Remove the front and rear lower link bolts from the rear suspension member.  
 23. Remove the front lower link to rear lower link bolts (A) and separate.

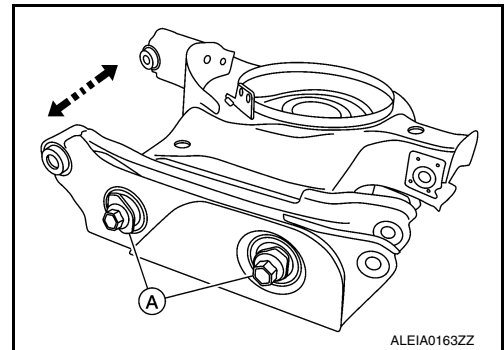

### Installation

Installation is in the reverse order of removal.

#### CAUTION:

- Do not reuse suspension arm nuts.
- Do not reuse front and rear lower link nuts.
- Remove the front under cover and place 2 jack stands under the front of the vehicle. Refer to [EXT-38, "FRONT UNDER COVER : Removal and Installation"](#)

#### WARNING:

**Jack stands must be placed under the front suspension member during installation.**

- Make sure that upper rubber seat is attached as shown.

#### CAUTION:

- Keep the upper rubber seat (1) in place during coil spring installation. The protrusion (A) on the upper rubber seat faces outside of vehicle.
- Align the tabs (C) to the upper rubber seat openings and securely fit on the bracket (2) to the tabs (B).

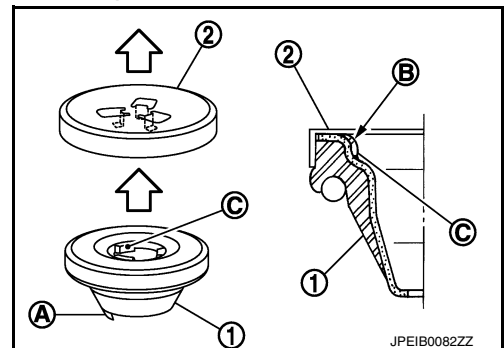

← : Body

- Match up the lower rubber seat indentions and the rear lower link grooves and attach.

## REAR SUSPENSION ASSEMBLY

### < UNIT REMOVAL AND INSTALLATION >

- When installing the coil spring (1), check coil spring is attached as shown.

(A): Vehicle upper side

(B): 1 paint mark

(C): 2 paint marks

(D): Vehicle inside

**CAUTION:**

**Position the coil spring with the two paint marks 3.5 turns from the bottom.**

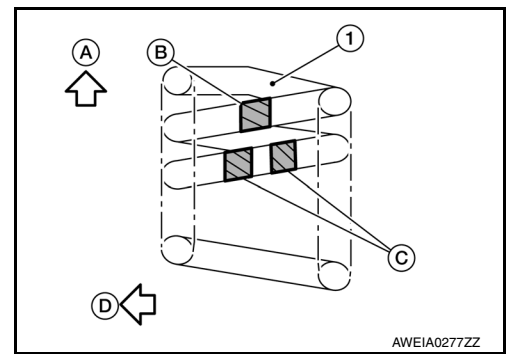

- Install coil spring by aligning lower end of the coil spring (1) to bump of lower spring seat (2).

(A) : Maximum gap 5 mm (0.20 in)

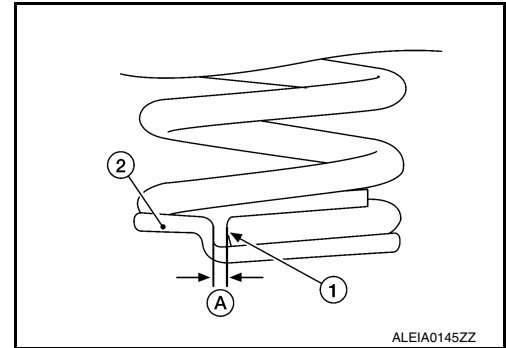

- Perform the final tightening of rear suspension member and axle installation position (rubber bushing) under unladen condition with tires on level ground.
- Check wheel alignment. Refer to [RSU-5, "Inspection and Adjustment"](#).
- Adjust neutral position of steering angle sensor. Refer to [BRC-64, "Description"](#).



# SERVICE DATA AND SPECIFICATIONS (SDS)

< SERVICE DATA AND SPECIFICATIONS (SDS)

## SERVICE DATA AND SPECIFICATIONS (SDS)

### SERVICE DATA AND SPECIFICATIONS (SDS)

#### General Specification (Rear)

INFOID:0000000012601408

Suspension type	Multi-link independent suspension
Shock absorber type	Double-acting hydraulic

#### Wheel Alignment (Unladen\*)

INFOID:0000000012601409

Camber Degree minute (Decimal degree)	Minimum	-1° 09' 36" (-1.16°)
	Nominal	-0° 39' 36" (-0.66°)
	Maximum	-0° 09' 36" (-0.16°)

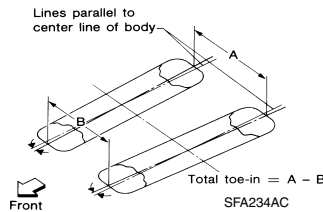

Tire size		215/60R16 or 215/55R17	235/45/R18	
Total toe-in	Distance (A - B)	Minimum	Out 1.6 mm (Out 0.063 in)	Out 1.5 mm (Out 0.059 in)
		Nominal	In 1.4 mm (In 0.055 in)	In 1.5 mm (In 0.059 in)
		Maximum	In 4.4 mm (In 0.173 in)	In 4.5 mm (In 0.177 in)
	Angle (LH and RH) Degree minute (Decimal degree)	Minimum	Out 0° 4' 48" (Out 0.08°)	
		Nominal	In 0° 07' 12" (In 0.12°)	
		Maximum	In 0° 19' 12" (In 0.32°)	

\*: Fuel, engine coolant, and lubricants are full. Spare tire, jack, hand tools, and mats are in designated positions.

#### Wheelarch Height (Unladen\*<sup>1</sup>)

INFOID:0000000012601410

##### UNITED STATES

Unit: mm (in)

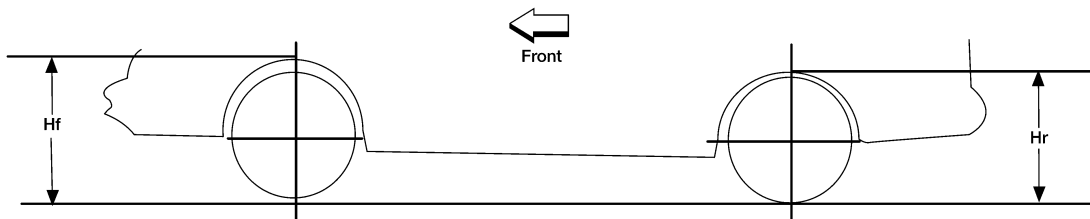

LEIA0085E

Engine	QR25DE			VQ35DE	
Tire size	215/60R16	215/55R17	235/45R18	235/45R18	
Grade	Except for SR			SR	Except for SR SR
Front (Hf)	706 (27.80)	708 (27.87)	713 (28.07)	712 (28.03)	711 (27.99)
Rear (Hr)	699 (27.52)	702 (27.64)	704 (27.72)	704 (27.72)	704 (27.72)

\*1: Fuel, engine coolant, and lubricants are full. Spare tire, jack, hand tools, and mats are in designated positions.

# SERVICE DATA AND SPECIFICATIONS (SDS)

< SERVICE DATA AND SPECIFICATIONS (SDS)

CANADA

Unit: mm (in)

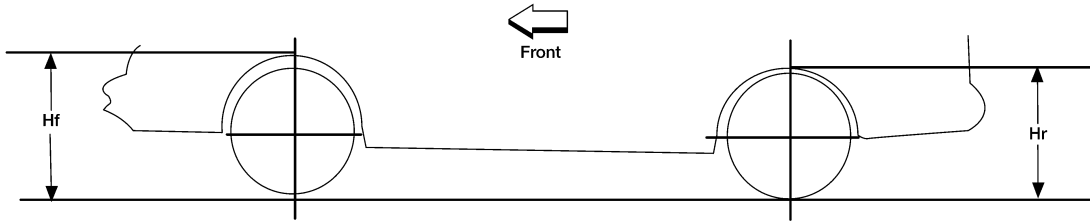

LEIA0085E

Engine	QR25DE			VQ35DE
Tire size	215/60R16	215/55R17	235/45R18	235/45R18
Front (Hf)	706 (27.80)	708 (27.87)	713 (28.07)	712 (28.03)
Rear (Hr)	700 (27.56)	702 (27.64)	705 (27.76)	705 (27.76)

\*1: Fuel, engine coolant, and lubricants are full. Spare tire, jack, hand tools, and mats are in designated positions.