

HEATER & AIR CONDITIONER

SECTION HA

CONTENTS

MANUAL AND AUTO

PRECAUTIONS AND PREPARATION	2
Precautions for Supplemental Restraint System (SRS) "AIR BAG".....	2
Precautions for Working with R-134a.....	2
Precautions for Working with Refrigerants.....	3
Precautions for Refrigerant Connection.....	4
Precautions for Servicing Compressor.....	5
Special Service Tools.....	6
R-134a Service Tools and Equipment.....	7
Precautions for Service Equipment.....	9
DESCRIPTION	11
Refrigeration Cycle.....	11
Component Layout.....	12
Discharge Air Flow.....	13

MANUAL

DESCRIPTION	14
Control Operation.....	14
TROUBLE DIAGNOSES	15
How to Perform Trouble Diagnoses for Quick and Accurate Repair.....	15
Operational Check.....	16
Symptom Chart.....	18
Preliminary Check.....	20
Performance Test Diagnoses.....	26
Performance Chart.....	28
Trouble Diagnoses for Abnormal Pressure.....	29
Harness Layout.....	33
Circuit Diagram.....	35
Wiring Diagram –HEATER–.....	36
Wiring Diagram –A/C, M–.....	37
Main Power Supply and Ground Circuit Check....	43
Diagnostic Procedures.....	44
Electrical Components Inspection.....	55
Control Linkage Adjustment.....	56

AUTO

DESCRIPTION	58
Introduction.....	58
Features.....	58
Control Operation.....	59
TROUBLE DIAGNOSES	61
How to Perform Trouble Diagnoses for Quick and Accurate Repair.....	61
Operational Check.....	62
Symptom Chart.....	66
Self-diagnosis.....	70
Preliminary Check.....	78
Performance Test Diagnoses.....	86
Performance Chart.....	88
Trouble Diagnoses for Abnormal Pressure.....	89
Harness Layout.....	93
Circuit Diagram.....	95
Wiring Diagram –A/C, A–.....	96
Main Power Supply and Ground Circuit Check..	102
Diagnostic Procedures.....	103
Electrical Components Inspection.....	119
Control Linkage Adjustment.....	120
SYSTEM DESCRIPTION	122
Overview of Control System.....	122
Control System Input Components.....	123
Control System Automatic Amplifier (Auto amp.).....	125
Control System Output Components.....	125

MANUAL AND AUTO

SERVICE PROCEDURES	134
Checking Refrigerant Leaks.....	134
R-134a Service Procedure.....	136
Compressor Lubricant Quantity.....	138
Refrigerant Lines.....	140
Compressor Mounting.....	141

CONTENTS (Cont'd.)

Belt Tension 141
 Fast Idle Control Device (FICD) 141
 Compressor..... 142
 Compressor Clutch 142
 Thermal Protector 145

SERVICE DATA AND SPECIFICATIONS
(SDS) 146
 General Specifications 146
 Inspection and Adjustment..... 146

GI
 MA

When you read wiring diagrams:

- Read GI section, "HOW TO READ WIRING DIAGRAMS".
- See EL section, "POWER SUPPLY ROUTING" for power distribution circuit.

When you perform trouble diagnoses, read GI section, "HOW TO FOLLOW FLOW CHART IN TROUBLE DIAGNOSES" and "HOW TO PERFORM EFFICIENT DIAGNOSIS FOR AN ELECTRICAL INCIDENT".

EW

IC

EC

EE

CI

MT

AT

FA

RA

BR

ST

RS

BT

HA

EL

IDX

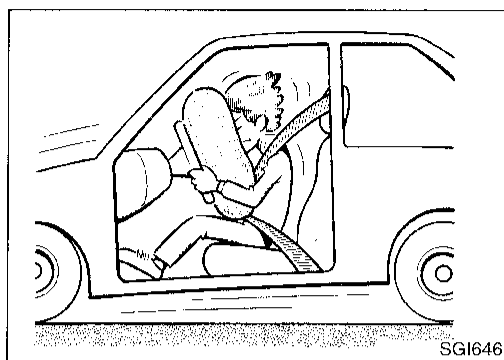

Precautions for Supplemental Restraint System (SRS) "AIR BAG"

The Supplemental Restraint System "Air Bag", used along with a seat belt, helps to reduce the risk or severity of injury to the driver and front passenger in a frontal collision. The Supplemental Restraint System consists of air bag modules (located in the center of the steering wheel and in the instrument panel on the passenger side), a diagnosis sensor unit, warning lamp, wiring harness and spiral cable. Information necessary to service the system safely is included in the **RS section** of this Service Manual.

WARNING:

- To avoid rendering the SRS inoperative, which could increase the risk of personal injury or death in the event of a collision which would result in air bag inflation, all maintenance must be performed by an authorized NISSAN dealer.
- Improper maintenance, including incorrect removal and installation of the SRS, can lead to personal injury caused by unintentional activation of the system.
- Do not use electrical test equipment on any circuit related to the SRS unless instructed to in this Service Manual. SRS wiring harnesses are covered with yellow insulation either just before the harness connectors or for the complete harness, for easy identification.

Precautions for Working with R-134a

WARNING:

- CFC-12 (R-12) refrigerant and R-134a refrigerant are not compatible. These refrigerants must never be mixed, even in the smallest amounts. If the refrigerants are mixed, compressor malfunction is likely.
- Use only specified lubricant for the R-134a A/C system and R-134a components. If lubricant other than that specified is used, compressor malfunction is likely.
- The specified R-134a lubricant rapidly absorbs moisture from the atmosphere. The following handling precautions must be observed:
 - a: When removing refrigerant components from a vehicle, immediately cap (seal) the component to minimize the entry of moisture from the atmosphere.
 - b: When installing refrigerant components to a vehicle, do not remove the caps (unseal) until just before connecting the components. Connect all refrigerant loop components as quickly as possible to minimize the entry of moisture into the system.
 - c: Only use the specified lubricant from a sealed container. Immediately reseal containers of lubricant. Without proper sealing, lubricant will become moisture saturated and should not be used.
 - d: Avoid breathing A/C refrigerant and lubricant vapor or mist. Exposure may irritate eyes, nose and throat. Remove R-134a from the A/C system using certified service equipment meeting requirements of SAE J2210 (R-134a recycling equipment) or J2209 (R-134a recovery equipment). If accidental system discharge occurs, ventilate work area before resuming service. Additional health and safety information may be obtained from refrigerant and lubricant manufacturers.
 - e: Do not allow lubricant to contact styrofoam parts. Damage may result.

Precautions for Working with Refrigerants

WARNING:

- Do not release refrigerant into the air. Use approved recovery/recycling equipment to capture the refrigerant every time an air conditioner system is discharged. Always follow the manufacturers recommendations for use of the recovery/recycling equipment.
- Always wear eye and hand protection (goggles and gloves) when working with any refrigerant or air conditioner system.
- Do not store or heat refrigerant containers above 52°C (125°F).
- Do not heat a refrigerant container with an open flame; if container warming is required, place the bottom of the container in a pail of warm water.
- Do not intentionally drop, puncture, or incinerate refrigerant containers.
- Keep refrigerant away from open flames: poisonous gas will be produced if refrigerant burns.
- Refrigerant will displace oxygen, therefore be certain to work in well ventilated areas to prevent suffocation.
- Do not introduce compressed air to any refrigerant container or refrigerant component.

GI

MA

EM

LC

EC

FE

CL

MT

AT

FA

RA

BR

ST

RS

BT

HA

EL

IX

Precautions for Refrigerant Connection

WARNING:

Make sure all refrigerant is discharged into the recycling equipment and the pressure in the system is less than atmospheric pressure. Then gradually loosen the discharge side hose fitting and remove it.

CAUTION:

When replacing or cleaning refrigerant cycle components, observe the following.

- Do not leave compressor on its side or upside down for more than 10 minutes. Compressor lubricant will enter low pressure chamber.
- When connecting tubes, always use a torque wrench and a back-up wrench.
- After disconnecting tubes, plug all openings immediately to prevent entry of dirt and moisture.
- When installing an air conditioner unit in the vehicle, connect the pipes as the final stage of the operation. Do not remove seal caps from pipes and other components until just before required for connection.
- Allow components stored in cool areas to warm to working area temperature before removing seal caps. This prevents condensation from forming inside A/C components.
- Thoroughly remove moisture from the refrigeration system before charging the refrigerant.
- Always replace used O-rings.
- When connecting tube, apply lubricant to portions shown in illustration. Be careful not to apply lubricant to threaded portion.

Name: Nissan A/C System Lubricant Type R

Part No.: KLH00-PAGR0

- O-ring must be closely attached to inflated portion of tube.
- After inserting tube into union until O-ring is no longer visible, tighten nut to specified torque.
- After connecting line, conduct leak test and make sure that there is no leakage. When the gas leaking point is found, disconnect that line and replace the O-ring. Then tighten connections of seal seat to the specified torque.

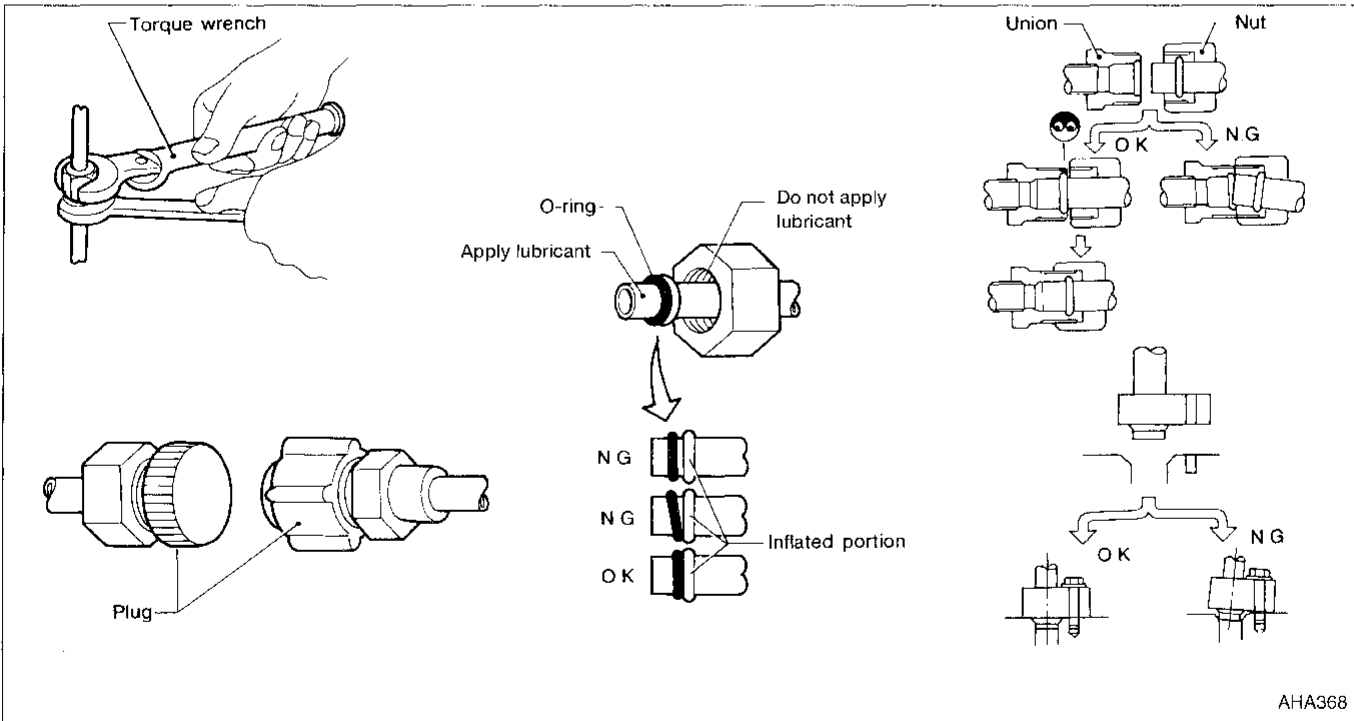

AHA368

Precautions for Servicing Compressor

- Plug all openings to prevent moisture and foreign matter from entering. GI
- Do not keep the compressor in the upside down position or laid on its side for more than 10 minutes.
- When replacing or repairing compressor, be sure to remove lubricant from the compressor and check the lubricant quantity extracted. MA
- When replacing or repairing compressor, follow Lubricant - Checking and Adjusting procedure exactly. Refer to "Compressor Lubricant Quantity", "SERVICE PROCEDURES", HA-138. EM
- Keep friction surfaces between clutch and pulley clean. If the surface is contaminated with oil, wipe it off by using a clean waste cloth moistened with thinner.
- After compressor service operation, turn the compressor shaft by hand more than five turns in both directions. This will equally distribute lubricant inside the compressor. After the compressor is installed, let the engine idle and operate the compressor for one hour. LC
- After replacing the compressor magnet clutch, apply voltage to the new one and check for normal operation. EC

FE

CL

MT

AT

FA

RA

BR

SI

RS

BT

HA

EL

IDX

Special Service Tools

The actual shapes of Kent-Moore tools may differ from those of special service tools illustrated here.

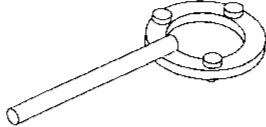
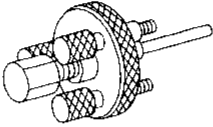
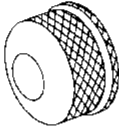
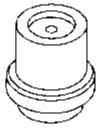

Tool number (Kent-Moore No.) Tool name	Description	Note
KV99231260 (J-38874) Clutch disc wrench	 <p>NT204</p>	Removing shaft nut and clutch disc
KV99232340 (J-38874) Clutch disc puller	 <p>NT206</p>	Removing clutch disc
KV99234330 (J-39024) Pulley installer	 <p>NT207</p>	Installing pulley
KV99233130 (J-39023) Pulley puller	 <p>NT208</p>	Removing pulley

R-134a Service Tools and Equipment

Never mix R-134a refrigerant and/or its specified lubricant with CFC-12 (R-12) refrigerant and/or its lubricant.

Separate and non-interchangeable service equipment must be used for each type of refrigerant/lubricant. Refrigerant container fittings, service hose fittings, and service equipment fittings (equipment which handles refrigerant and/or lubricant) are different between CFC-12 (R-12) and R-134a. This is to avoid mixed use of the refrigerants/lubricants.

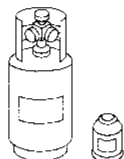

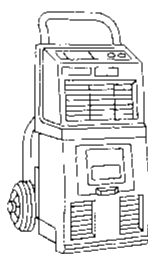
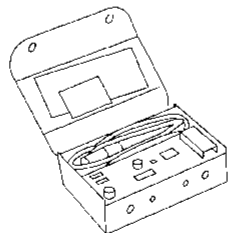

Adapters to convert from one size fitting to the other must never be used: refrigerant/lubricant contamination will occur and compressor failure will result.

Tool number (Kent-Moore No.) Tool name	Description	Note
R-134a refrigerant	 NT196	Container color: Light blue Container marking: R-134a Fitting size: Thread size ● large container 1/2"-16 ACME
KLH00-PAGRO (—) Nissan A/C System Lubricant Type R	 NT197	Type: Polyalkylene glycol oil (PAG), type R Application: R-134a vane rotary compressors (Nissan only) Lubricity: 40 ml (1.4 US fl oz, 1.4 Imp fl oz)
(J-39500-NI) Recovery/Recycling equipment (ACR4)	 NT195	Function: Refrigerant Recovery and Recycling and Recharging
(J-39400) Electronic leak detector	 NT198	Power supply: ● DC 12 V (Cigarette lighter)

GI
 MA
 EM
 LG
 EC
 PE
 CL
 MT
 AT
 FA
 RA
 BR
 ST
 RS
 BT
 HA
 EL
 BX

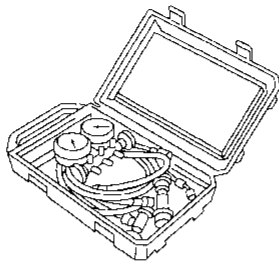
PRECAUTIONS AND PREPARATION MANUAL AND AUTO

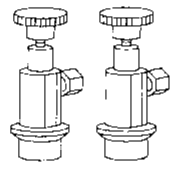
R-134a Service Tools and Equipment (Cont'd)

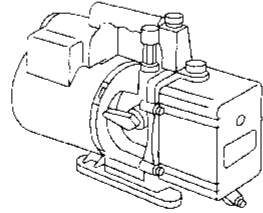
Tool number (Kent-Moore No.) Tool name	Description	Note
(J-39183) Manifold gauge set (with hoses and couplers)	 <p style="text-align: center;">NT199</p>	<p>Identification:</p> <ul style="list-style-type: none"> ● The gauge face indicates R-134a. <p>Fitting size: Thread size</p> <ul style="list-style-type: none"> ● 1/2"-16 ACME
<p>Service hoses</p> <ul style="list-style-type: none"> ● High-side hose (J-39501-72) ● Low-side hose (J-39502-72) ● Utility hose (J-39476-72) 	 <p style="text-align: center;">NT201</p>	<p>Hose color:</p> <ul style="list-style-type: none"> ● Low hose: Blue with black stripe ● High hose: Red with black stripe ● Utility hose: Yellow with black stripe or green with black stripe <p>Hose fitting to gauge:</p> <ul style="list-style-type: none"> ● 1/2"-16 ACME
<p>Service couplers</p> <ul style="list-style-type: none"> ● High-side coupler (J-39500-20) ● Low-side coupler (J-39500-24) 	 <p style="text-align: center;">NT202</p>	<p>Hose fitting to service hose:</p> <ul style="list-style-type: none"> ● M14 x 1.5 fitting (optional) or permanently attached
(J-39650) Refrigerant weight scale	 <p style="text-align: center;">NT200</p>	<p>For measuring of refrigerant</p> <p>Fitting size: Thread size</p> <ul style="list-style-type: none"> ● 1/2"-16 ACME
(J-39649) Vacuum pump (Including the isolator valve)	 <p style="text-align: center;">NT203</p>	<p>Capacity:</p> <ul style="list-style-type: none"> ● Air displacement: 4 CFM ● Micron rating: 20 microns ● Oil capacity: 482 g (17 oz) <p>Fitting size: Thread size</p> <ul style="list-style-type: none"> ● 1/2"-16 ACME

Precautions for Service Equipment

RECOVERY/RECYCLING EQUIPMENT

Follow the manufacturer's instructions for machine operation and machine maintenance. Never introduce any refrigerant other than that specified into the machine.

ELECTRONIC LEAK DETECTOR

Follow the manufacturer's instructions for tester operation and tester maintenance.

VACUUM PUMP

The lubricating oil contained inside the vacuum pump is not compatible with the specified lubricant for R-134a A/C systems. The vent side of the vacuum pump is exposed to atmospheric pressure. Therefore, if the pump is switched off after evacuation the lubricating oil may migrate into the hose. To prevent this, isolate the pump from the hose after evacuation (vacuuming). This migration is avoided by placing a manual shut-off valve near the hose-to-pump connection, as follows:

- Usually vacuum pumps have a manual isolator valve as part of the pump. Close this valve to isolate the service hose from the pump.
- For pumps without an isolator valve, use a hose equipped with a manual shut-off valve near the pump end. Close the valve to isolate the hose from the pump.
- If the hose has an automatic shut-off valve, disconnect the hose from the pump. As long as the hose is connected, the valve is open and lubricating oil may migrate.

Some one-way valves open when vacuum is applied and close under a no vacuum condition. Such valves may restrict the pump's ability to pull a deep vacuum and are not recommended.

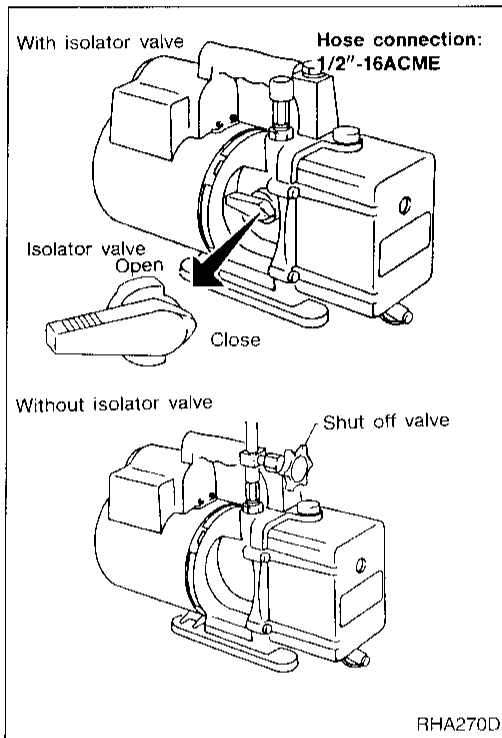

RHA270D

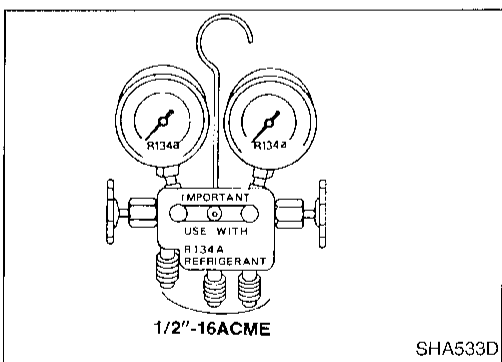

SHA533D

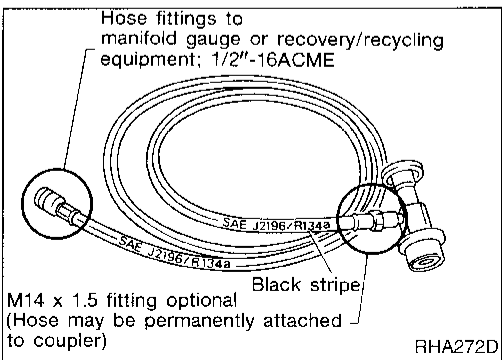

RHA272D

MANIFOLD GAUGE SET

Be sure the gauge set has 1/2"-16 ACME threaded connections for service hoses. Confirm the set has been used only with refrigerant R-134a along with specified lubricants.

SERVICE HOSES

Be certain that the service hoses display the markings described (colored hose with black stripe). Be certain that all hoses include positive shut-off devices (either manual or automatic) near the end of the hoses opposite the manifold gauge.

GI
HA
EM
LC
EC
FE
CL
WT
AT
FA
HA
BR
SI
RS
BT
HA
EL
IX

Precautions for Service Equipment (Cont'd)

SERVICE COUPLERS

Never attempt to connect R-134a service couplers to an CFC-12 (R-12) A/C system. The R-134a couplers will not properly connect to the CFC-12 (R-12) system. However, if an improper connection is attempted, discharging and contamination can occur.

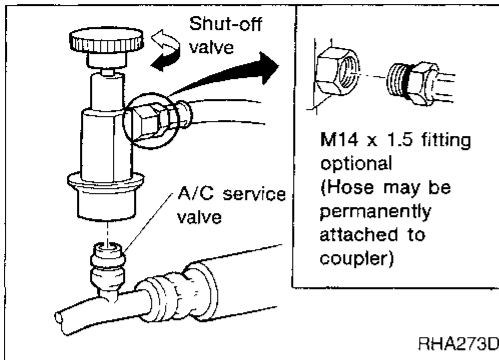

Shut-off valve rotation	A/C service valve
Clockwise	Open
Counterclockwise	Close

REFRIGERANT WEIGHT SCALE

When using a scale which controls refrigerant flow electronically, assure the following:

- Hose fitting size is 1/2"-16 ACME
- No refrigerant other than R-134a (along with specified lubricant) has been used with the scale.

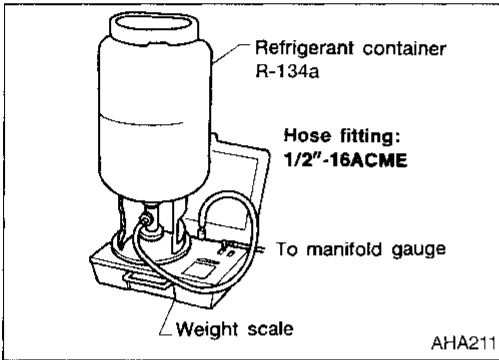

CHARGING CYLINDER

Using a charging cylinder is not recommended. Refrigerant may be vented into the air through the cylinder's top valve when filling the cylinder.

Refrigeration Cycle

REFRIGERANT FLOW

The refrigerant flow is in the standard pattern. Refrigerant flows through the compressor, condenser, liquid tank, evaporator, and back to the compressor.

The refrigerant evaporation through the evaporator coil is controlled by an externally equalized expansion valve, located inside the evaporator case.

REFRIGERANT SYSTEM PROTECTION

Triple-pressure switch

The triple or dual-pressure switch is located on the liquid tank. If the system pressure rises or falls out of specifications, the switch opens to interrupt compressor clutch operation. The triple-pressure switch closes to turn on the cooling fan to reduce system pressure (USA model only).

Pressure relief valve

The refrigerant system is protected by a pressure relief valve. The valve is located on the end of the flexible high pressure hose near the compressor. When refrigerant system pressure increases abnormally [over 3,727 kPa (38 kg/cm², 540 psi)], the relief valve's port opens. The valve then releases refrigerant into the atmosphere.

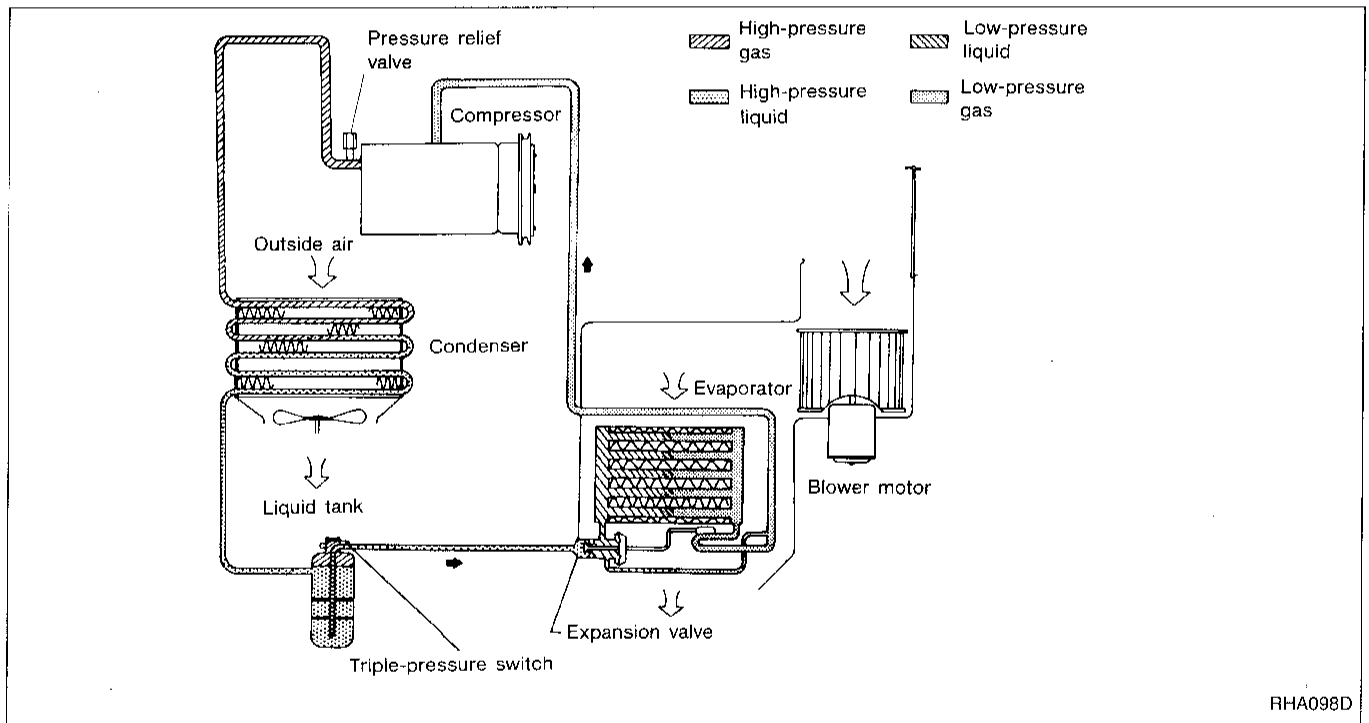

Component Layout

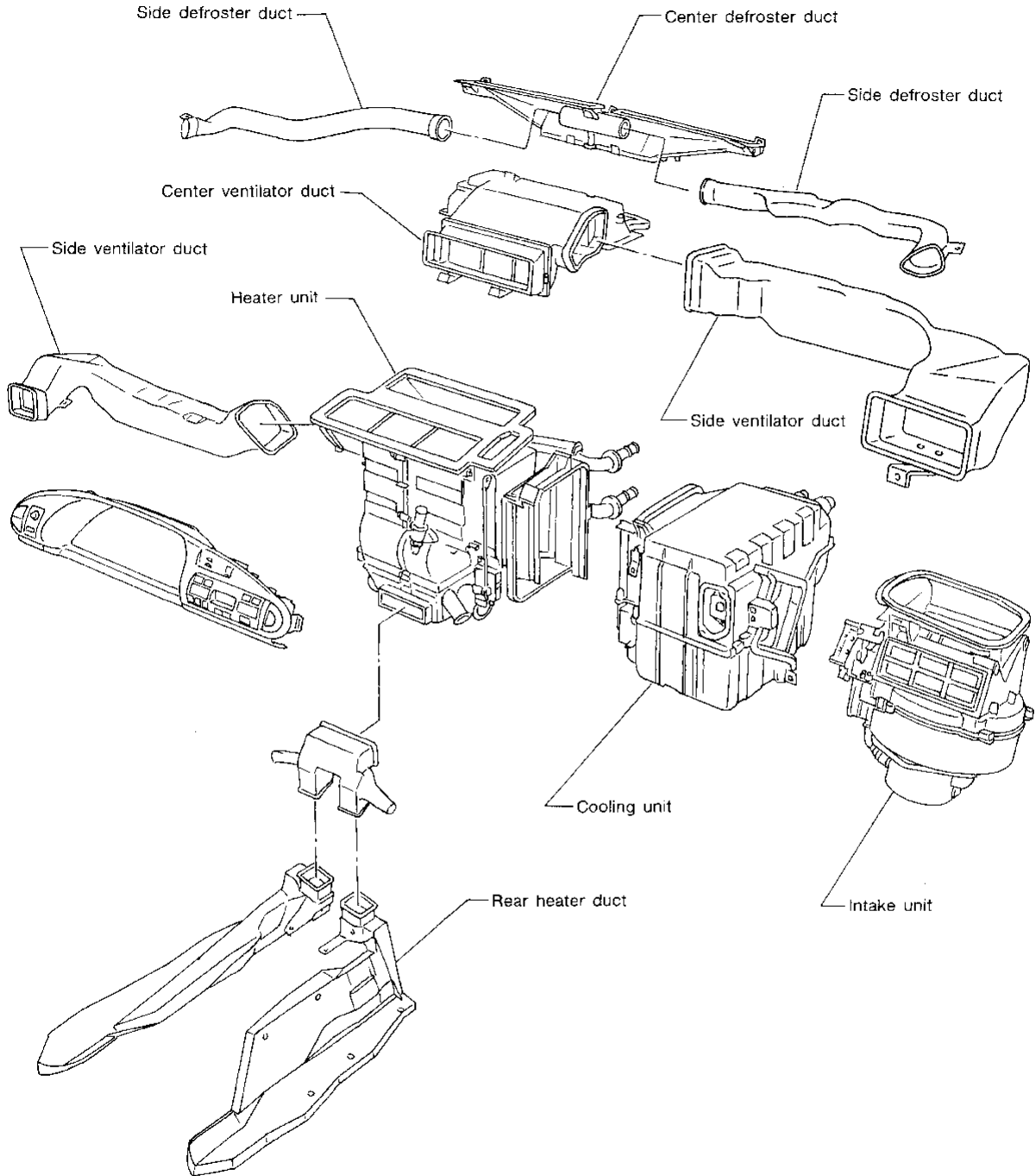

Discharge Air Flow

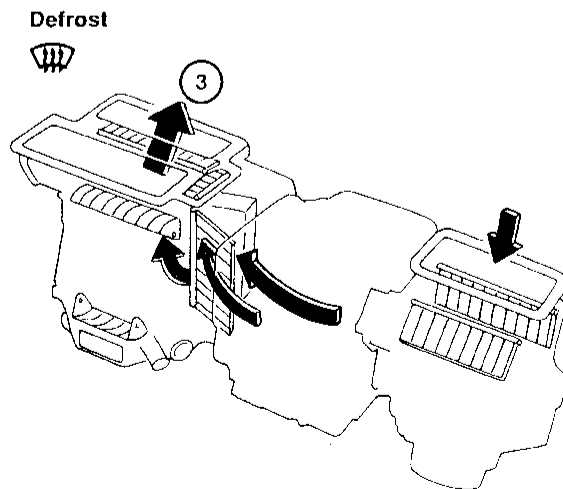
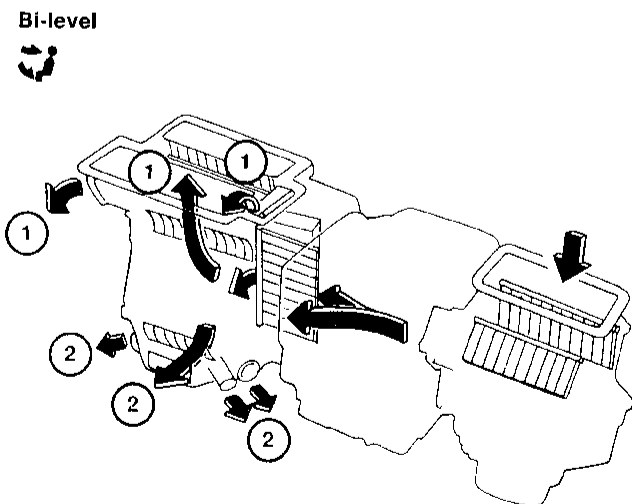
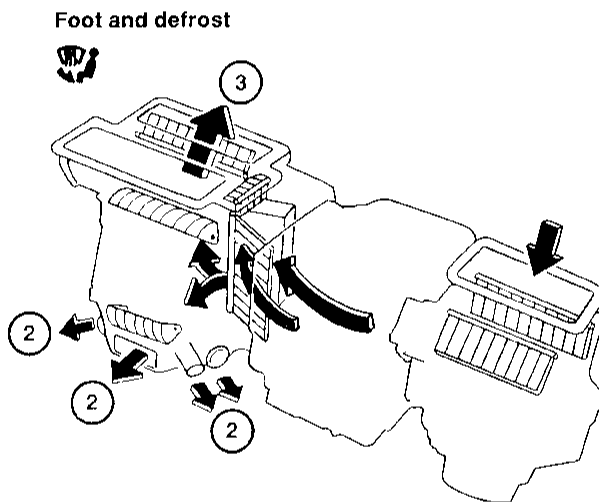
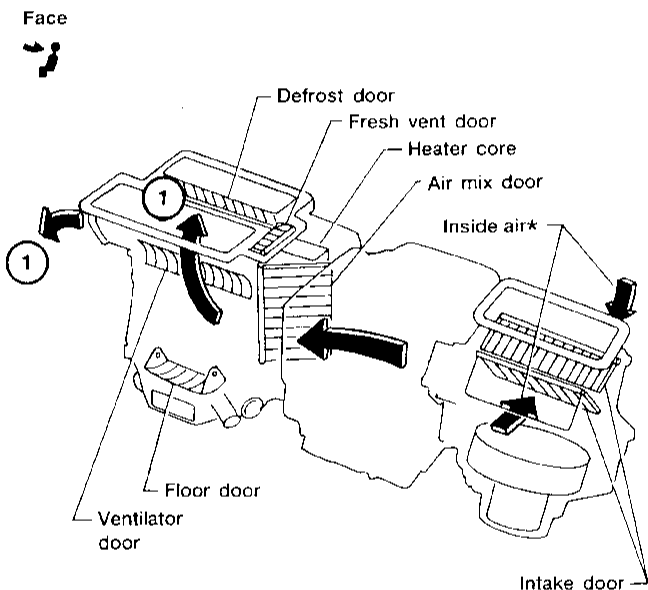
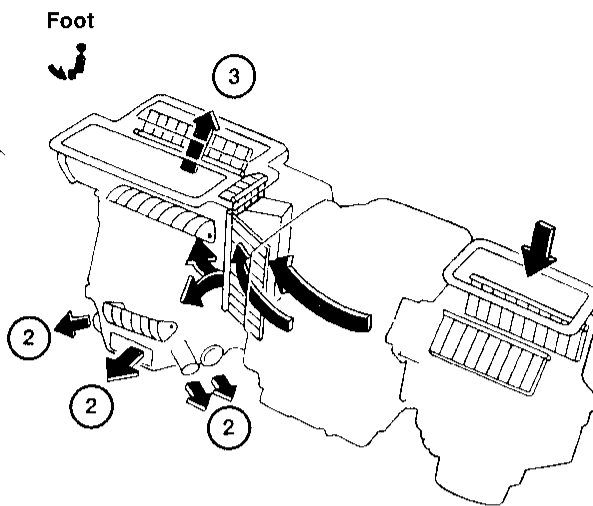
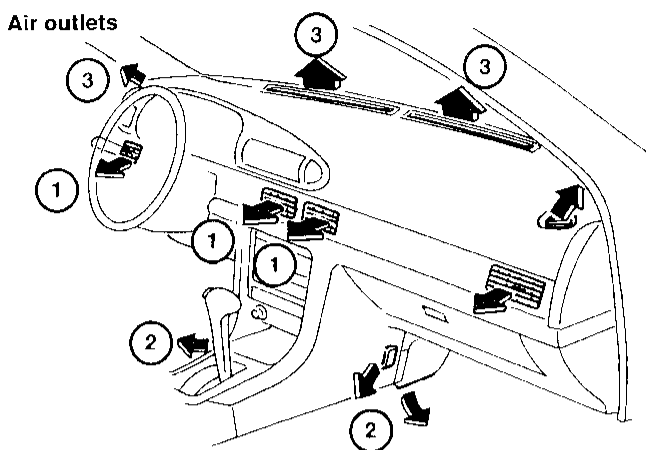

- 1 : To face
- 2 : To foot
- 3 : To defrost

* : When recirculation switch is ON

For air flow %, refer to "Operational Check,"
"TROUBLE DIAGNOSES."

AHA877

CI
MA
EW
LC
EC
FE
CL
MT
AT
FA
RA
BH
ST
RS
BT
HA
EL
IX

Control Operation

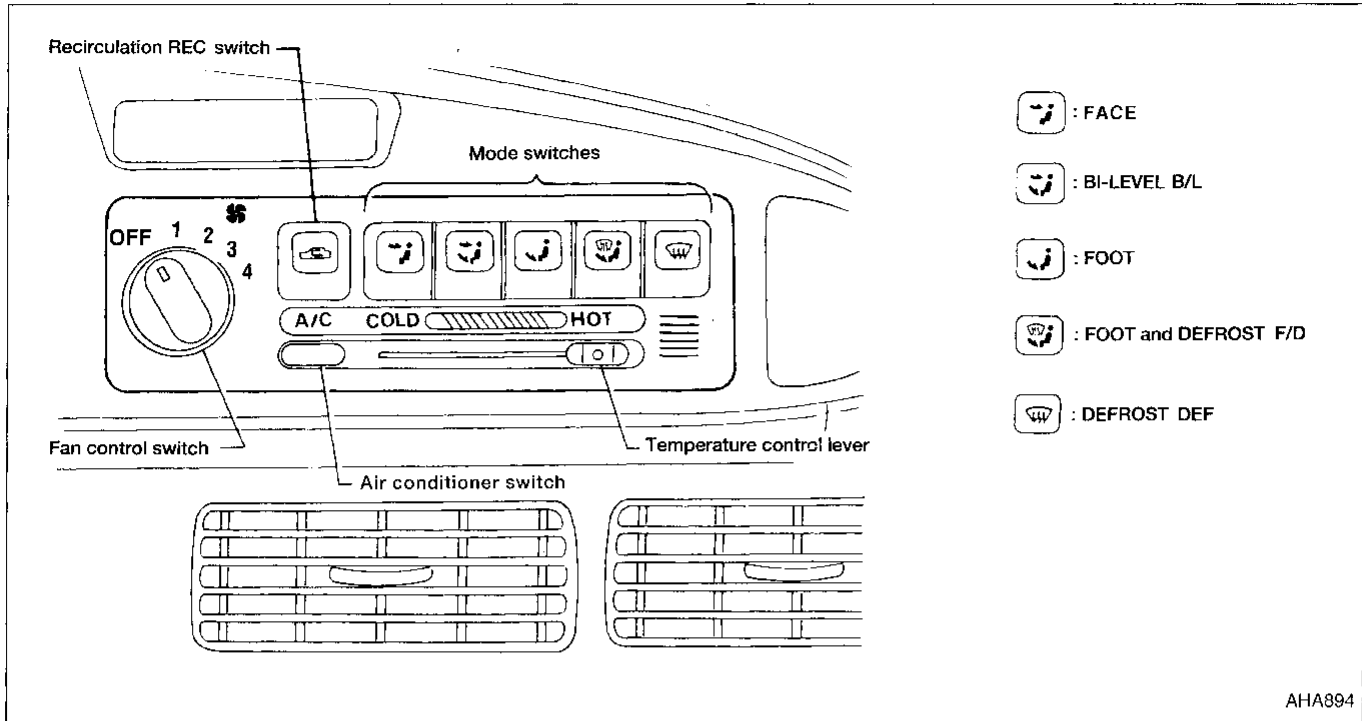
**FAN CONTROL SWITCH**

This switch turns the fan ON and OFF, and controls fan speed.

MODE SWITCHES

These switches control the outlet air flow.

The indicator lamp will also light when the switch is depressed.

When DEF or F/D mode is selected, the push control unit sets the intake door to FRESH.

The compressor turns on when DEF mode is selected.

TEMPERATURE CONTROL LEVER

This lever allows you to adjust the temperature of the discharge air.

RECIRCULATION SWITCH

OFF position: Outside air is drawn into the passenger compartment.

ON position: Interior air is recirculated inside the vehicle.

The indicator lamp will also light.

Recirculation is canceled when DEF or F/D mode is selected, and resumes when another mode is chosen.

AIR CONDITIONER SWITCH

The air conditioner switch controls the A/C system. When the switch is depressed with the fan ON, the compressor will turn ON. The indicator lamp will also light.

The air conditioner cooling function operates only when the engine is running.

How to Perform Trouble Diagnoses for Quick and Accurate Repair

WORK FLOW

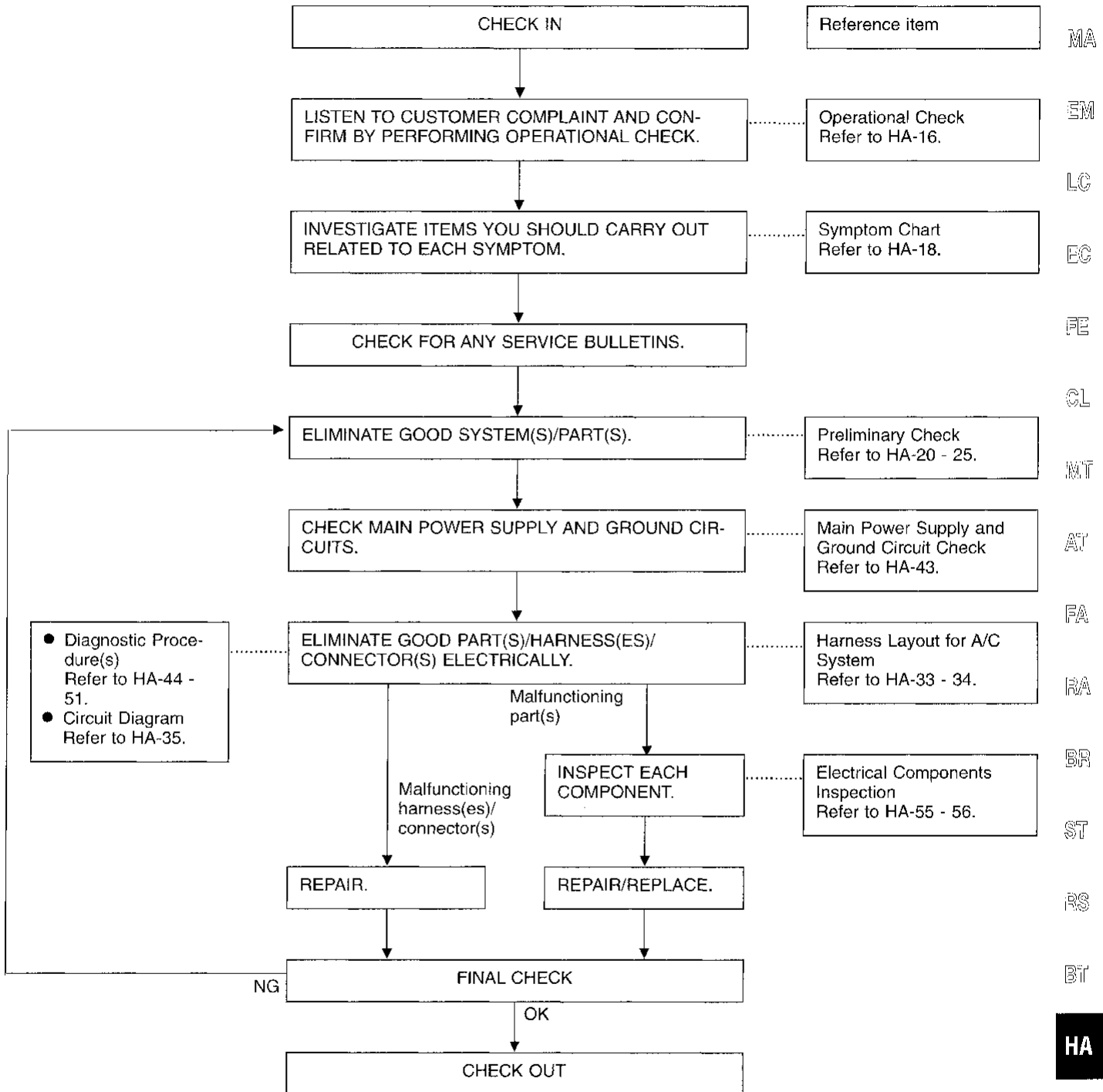

GE
MA
EM
LC
EC
FE
CL
MT
AT
FA
RA
BR
ST
BS
BT
HA
EL
DX

Operational Check

The purpose of the operational check is to confirm that the system operates properly.

CONDITIONS:

- Engine running and at normal operating temperature.

PROCEDURE:

1. Check blower

- Turn fan switch to 1-speed.
Blower should operate on 1-speed.
- Then turn fan switch to 2-speed, and continue checking blower speed until all speeds are checked.
- Leave blower on 4-speed.

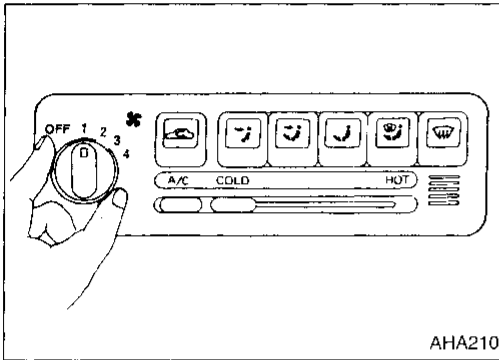

AHA210

2. Check discharge air

- Press each mode switch.

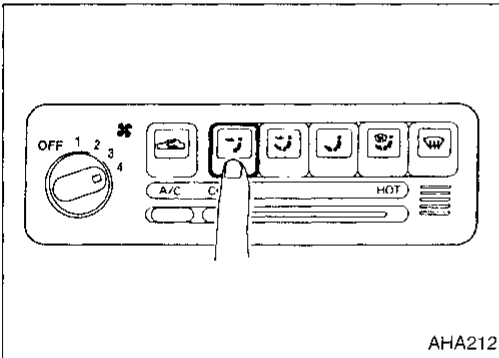

AHA212

- Confirm that discharge air comes out according to the air distribution table at left, and that the indicator lamp illuminates.

Refer to "Discharge Air Flow", HA-13.





NOTE:

Confirm that the compressor clutch is engaged (visual inspection) and intake door position is at FRESH when the DEF  mode is selected.

Confirm that the intake door position is at FRESH when the F/D  mode is selected.

Intake door position is checked in the next step.

Discharge air flow

Switch mode/ indicator	Air outlet/distribution		
	Face	Foot	Defrost
	100%	—	—
	60%	40%	—
	—	78%	22%
	—	55%	45%
	—	—	100%

AHA903

Operational Check (Cont'd)

3. Check recirculation

- a. Press REC  switch. Recirculation indicator should illuminate.
- b. Listen for intake door position change (you should hear blower sound change slightly).

NOTE:

Recirculation does not operate in DEF  and F/D  modes.

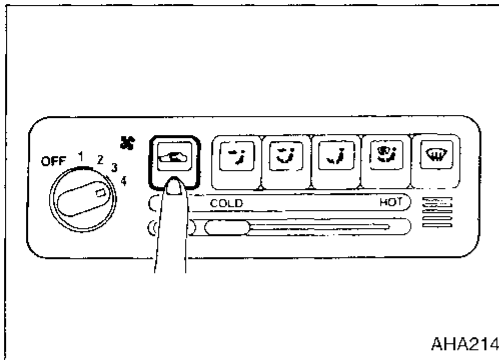

AHA214

4. Check temperature decrease

- a. Slide temperature control lever to full cold.
- b. Check for cold air at discharge air outlets.

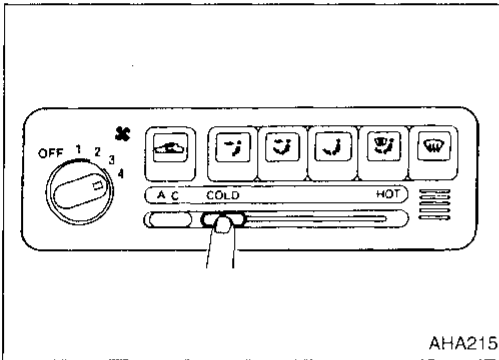

AHA215

5. Check temperature increase

- a. Slide temperature control lever to full hot.
- b. Check for hot air at discharge air outlets.

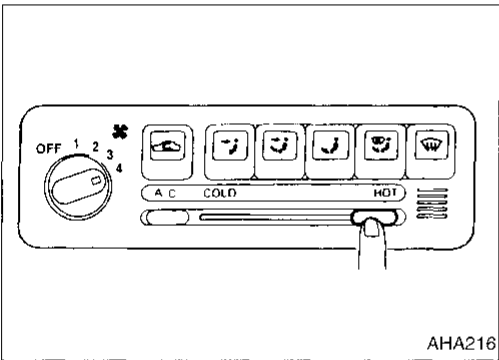

AHA216

6. Check air conditioner switch

Turn the fan control switch to the desired (1 to 4 speed) position and push the A/C switch to turn ON the air conditioner.

The indicator lamp should come on when air conditioner is ON.

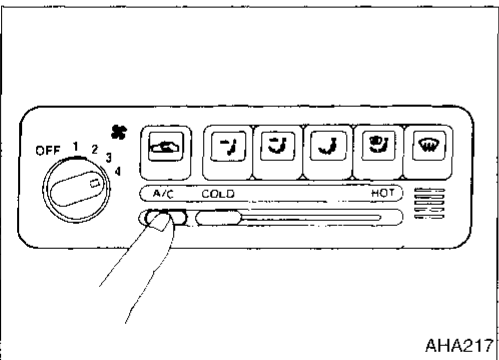

AHA217

GF

WA

EM

LC

EC

FE

OL

MT

AT

FA

RA

BR

ST

FS

BT

HA

EL

IDX

Symptom Chart

DIAGNOSTIC TABLE

PROCEDURE	Preliminary Check						Diagnostic Procedure					Main Power Supply and Ground Circuit Check		
	HA-20	HA-21	HA-22	HA-23	HA-24	HA-25	HA-44	HA-46	HA-48	HA-49	HA-51	HA-43	HA-43	HA-43
REFERENCE PAGE	HA-20	HA-21	HA-22	HA-23	HA-24	HA-25	HA-44	HA-46	HA-48	HA-49	HA-51	HA-43	HA-43	HA-43
SYMPTOM	Preliminary check 1	Preliminary check 2	Preliminary check 3	Preliminary check 4	Preliminary check 5	Preliminary check 6	Diagnostic procedure 1	Diagnostic procedure 2	Diagnostic procedure 3	Diagnostic procedure 4	Diagnostic procedure 5	20A Fuses (#7, #8)	10A Fuse (#6)	Push control unit
A/C does not blow cold air.		①					○			○	○	○	○	
Insufficient heating.						①	○							
Blower motor does not rotate.		①					②					○		
Air outlet does not change.				①				②					○	○
Intake door does not change in FACE, B/L or FOOT mode.									①				○	○
Intake door is not set at FRESH in DEF or F/D mode.	①								○				○	○
Air mix door does not change.		①								②			○	
Magnet clutch does not engage when A/C switch and fan switch are ON.		①									②		○	
Magnet clutch does not engage in DEF mode.		①	②							○			○	
Noise.					①									

①, ②: The number means checking order.

○: Checking order depends on malfunction in each flow chart.

Preliminary Check

PRELIMINARY CHECK 1

Intake door is not set at FRESH in DEF or F/D mode.

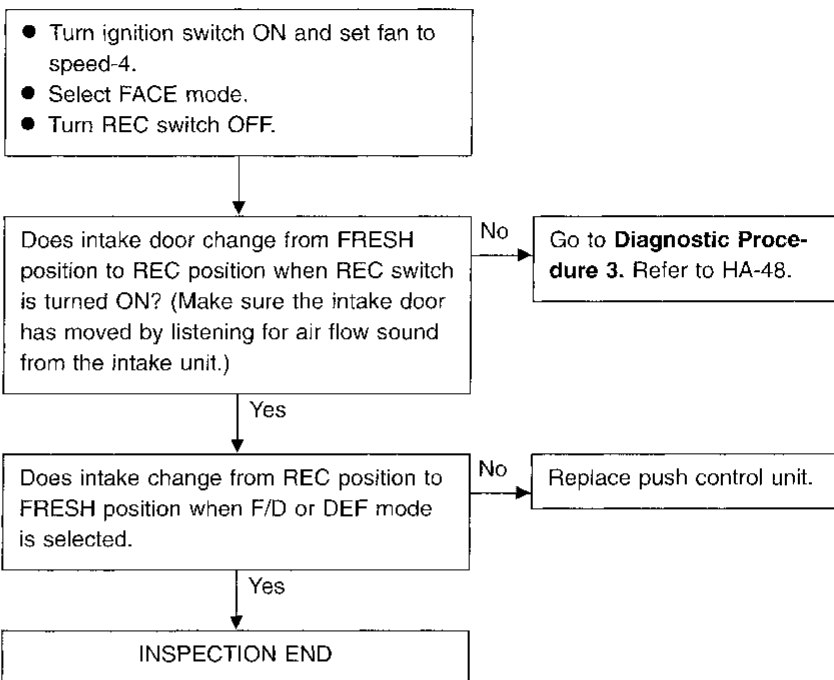

Preliminary Check (Cont'd)

PRELIMINARY CHECK 2

A/C does not blow cold air.

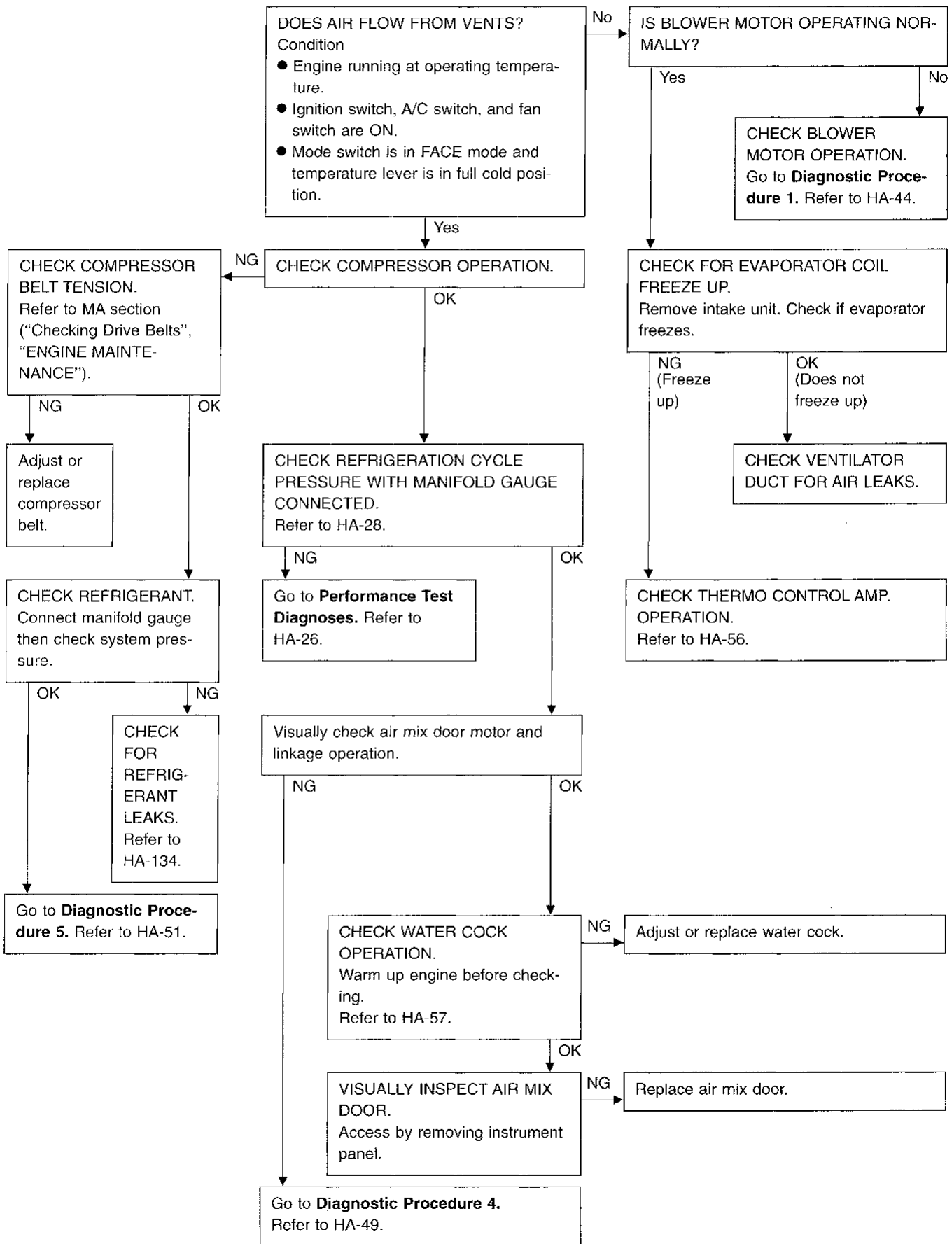

GI
MA
EM
LC
EC
FE
CL
WT
AT
FA
HA
BR
ST
RS
BT
HA
EL
IDX

Preliminary Check (Cont'd)

PRELIMINARY CHECK 3

Magnet clutch does not engage in DEF mode.

- Perform PRELIMINARY CHECK 2 before referring to the following flow chart.

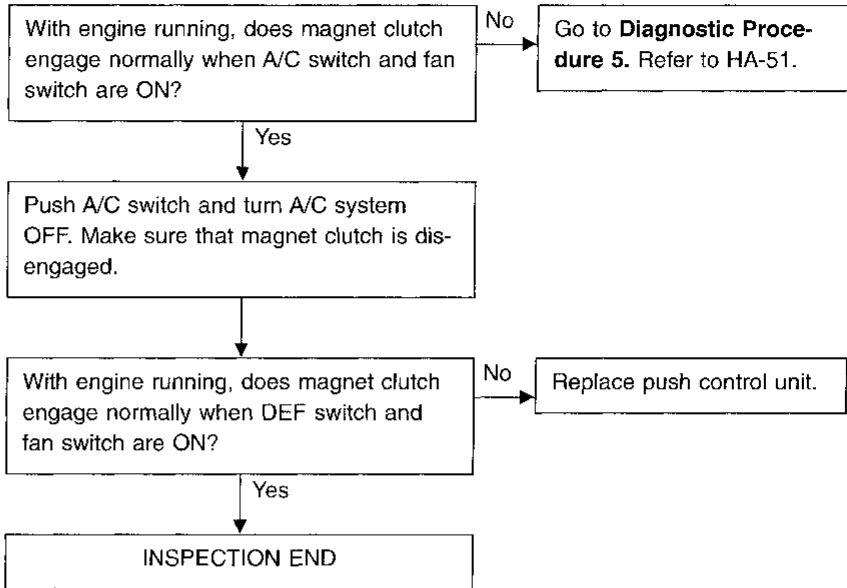

Preliminary Check (Cont'd)

PRELIMINARY CHECK 4

Air outlet does not change.

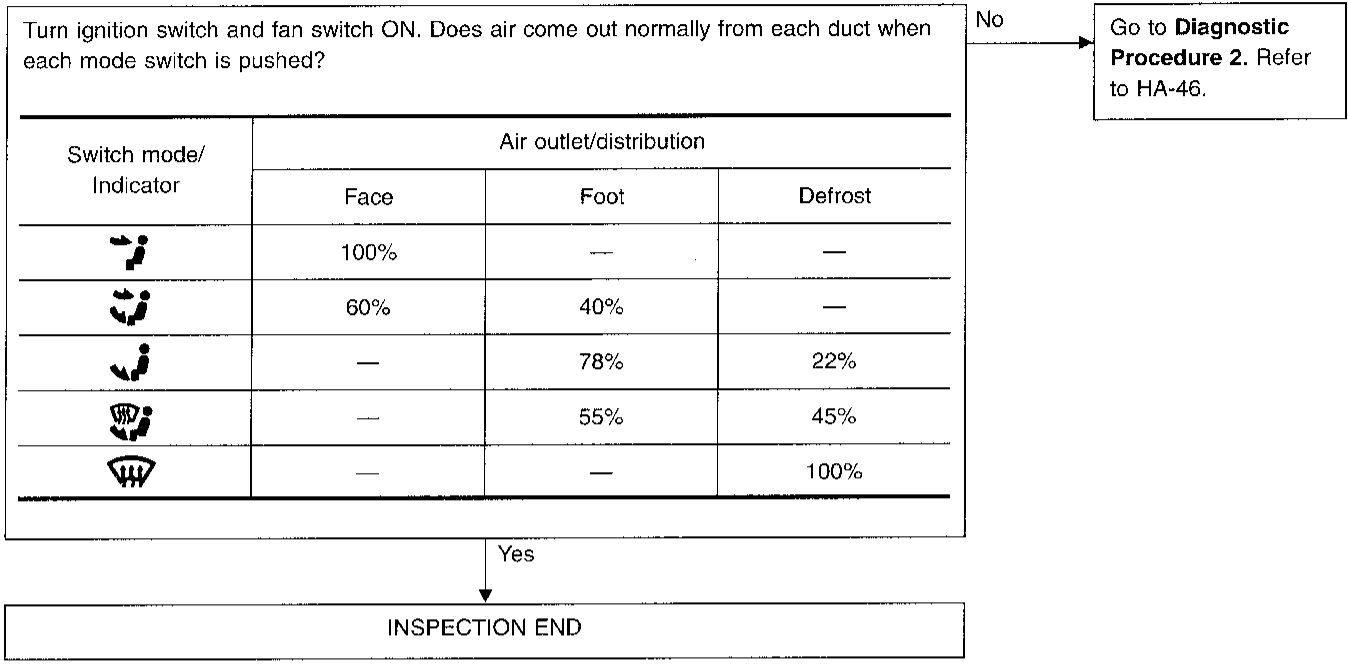

CI
WA
EM
LC
EC
FE
CL
MT
AT
FA
RA
BR
ST
RS
BT
HA
EL
IDX

Preliminary Check (Cont'd)

PRELIMINARY CHECK 5

Noise.

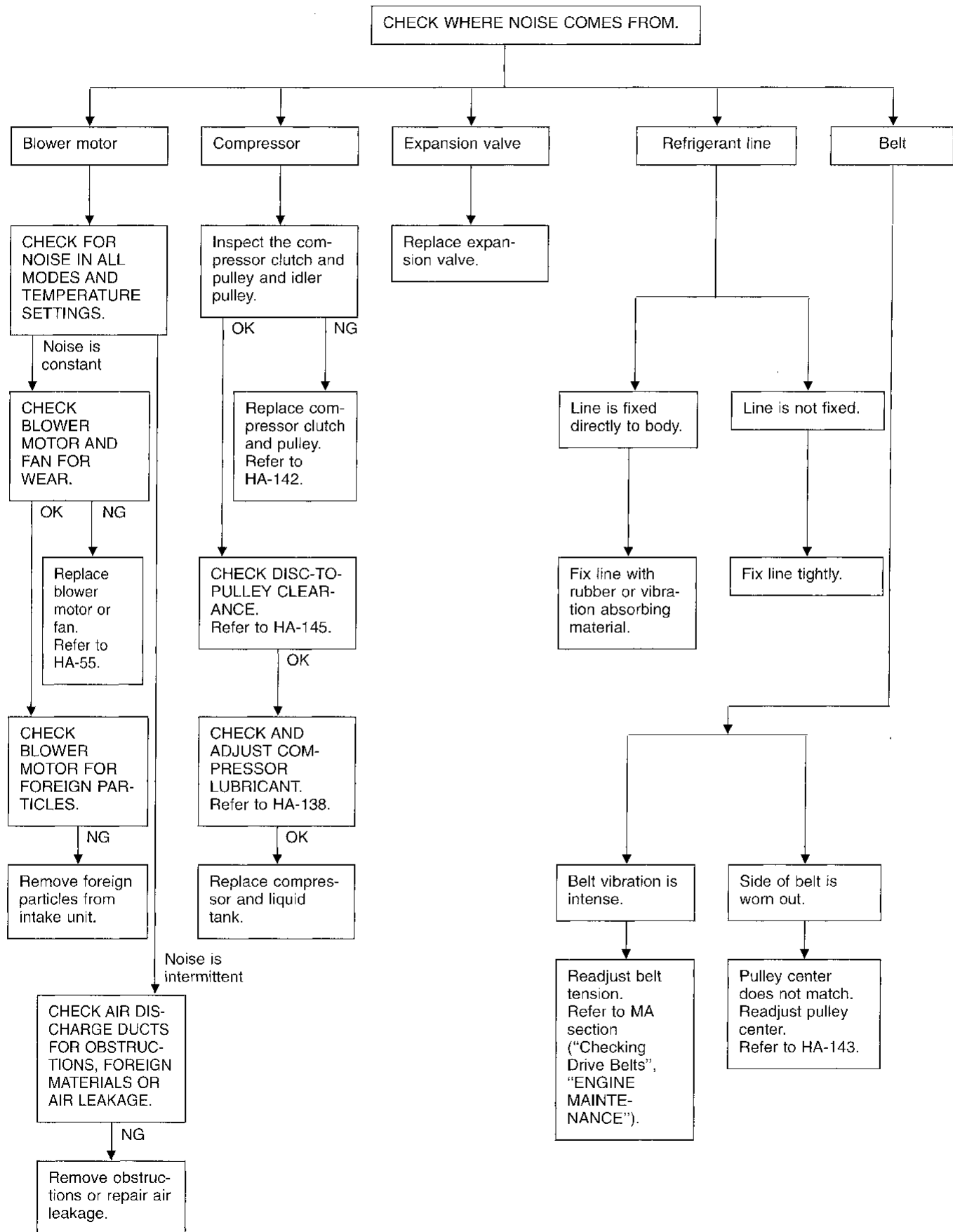

Preliminary Check (Cont'd)

PRELIMINARY CHECK 6

Insufficient heating.

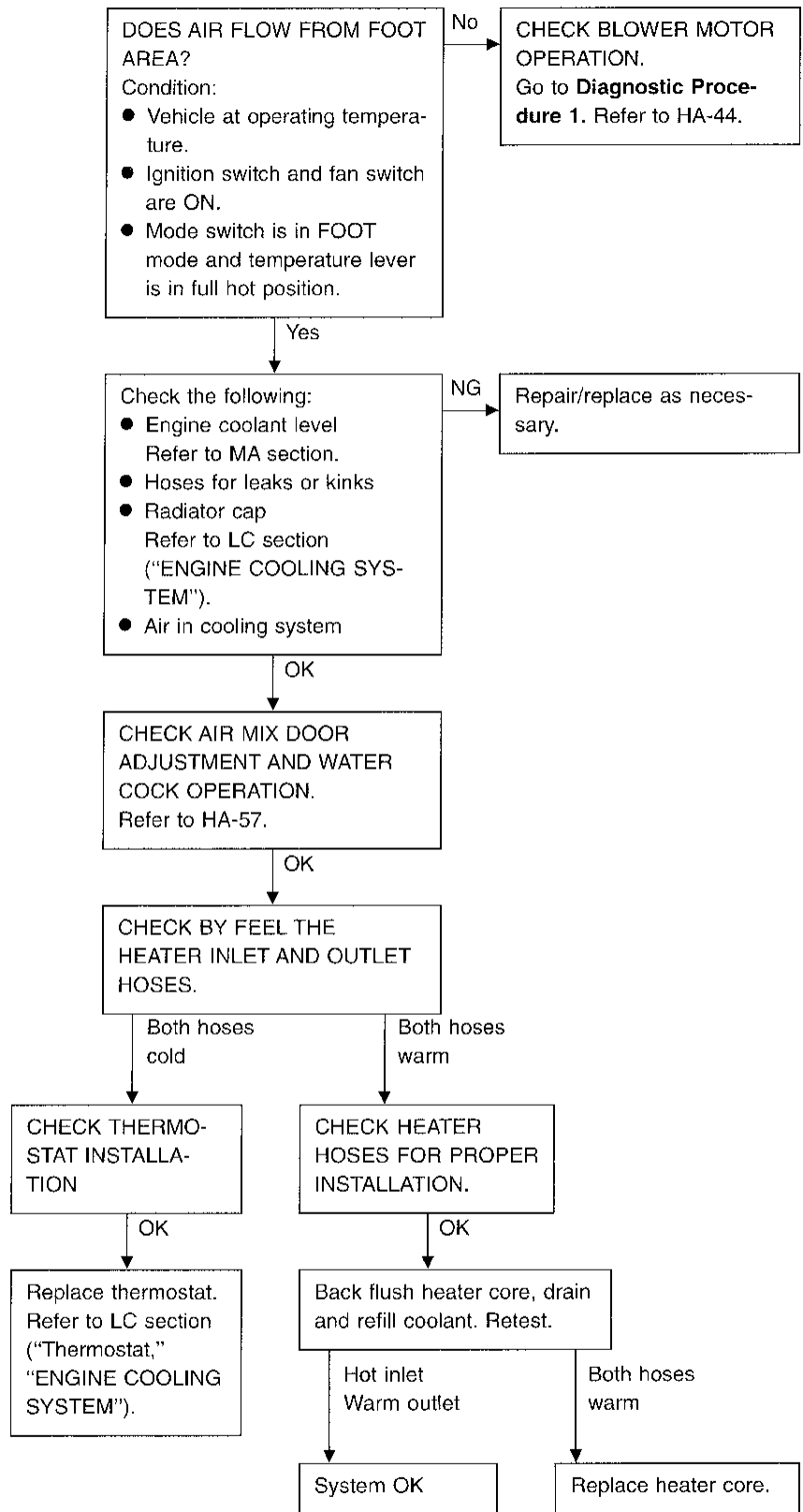

GI
MA
EM
LC
EC
FE
CL
MT
AT
FA
RA
BR
ST
RS
BT
HA
EL
IDX

Performance Test Diagnoses

INSUFFICIENT COOLING

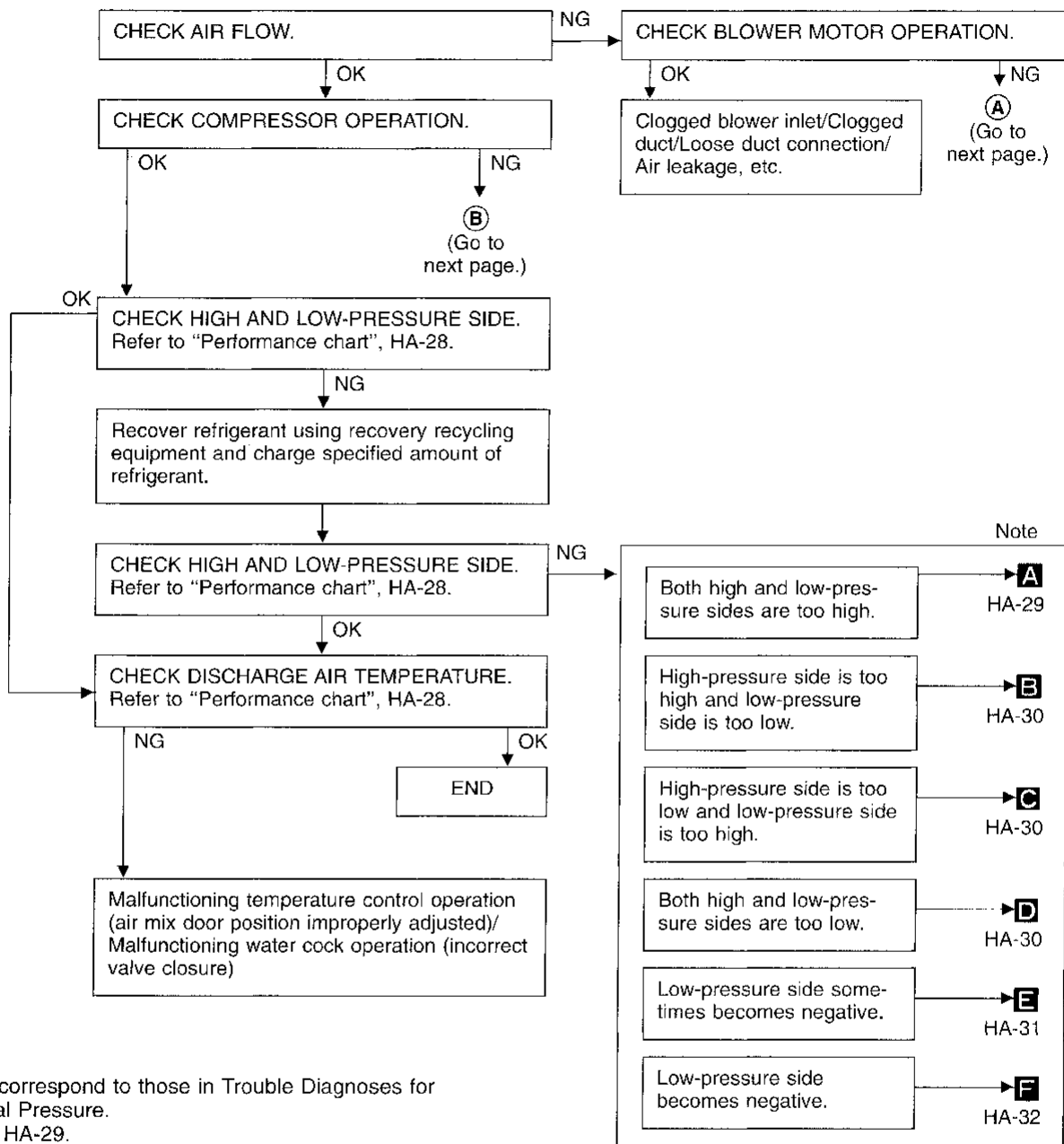

Performance Test Diagnoses (Cont'd)

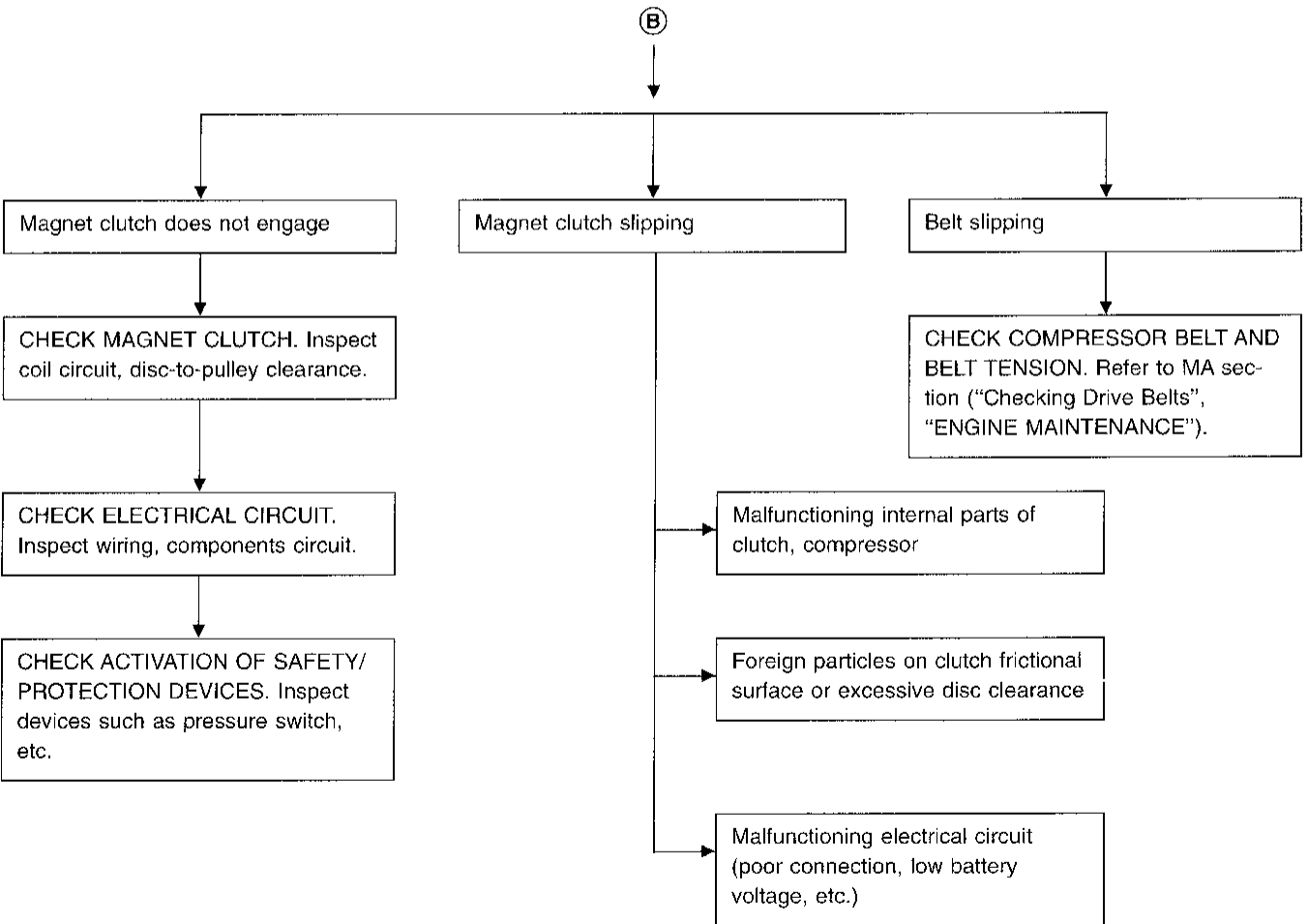
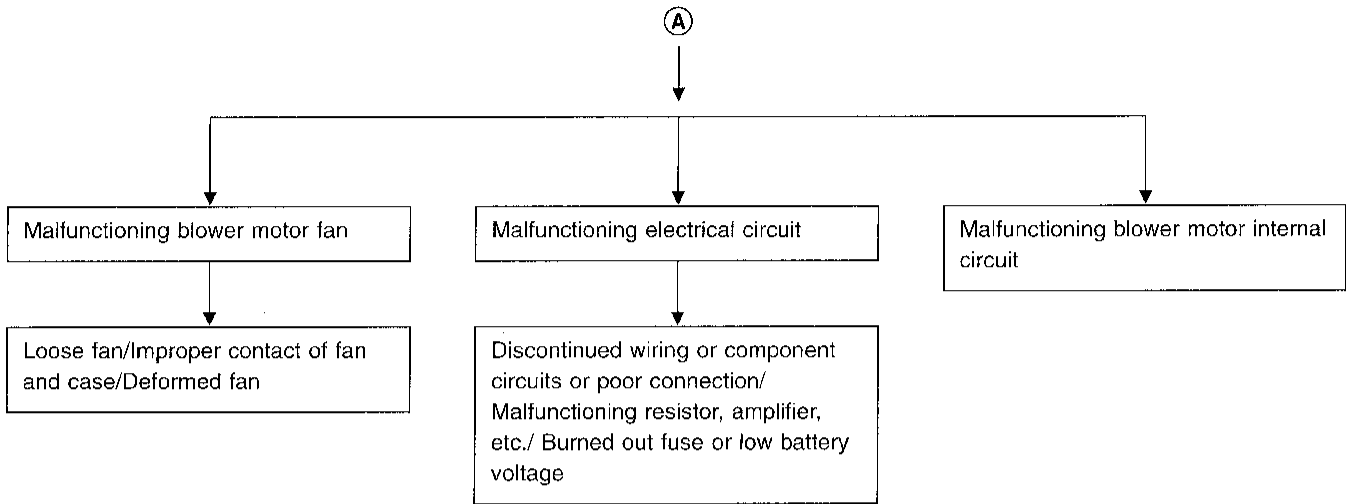

GI
MA
EM
LC
EC
FE
CL
MT
AT
FA
RA
BR
ST
RS
BT
HA
HL
IDX

Performance Chart

TEST CONDITION

Testing must be performed as follows:

Vehicle location: Indoors or in the shade (in a well ventilated place)

Doors: Closed

Door window: Open

Hood: Open

TEMP. setting: Max. COLD

Discharge Air: Face Vent

REC switch: (Recirculation) set

Fan speed: High speed

A/C switch: ON

Engine speed: 1,500 rpm

Operate the air conditioner system for 10 minutes before taking measurements.

TEST READING

Recirculating-to-discharge air temperature table

Inside air at blower assembly inlet for recirculation*		Discharge air temperature at center ventilator °C (°F)
Relative humidity %	Air temperature °C (°F)	
50 - 60	20 (68)	4.0 - 5.4 (39 - 42)
	25 (77)	4.2 - 5.6 (40 - 42)
	30 (86)	8.5 - 11.1 (47 - 52)
	35 (95)	13.5 - 16.7 (56 - 62)
	40 (104)	18.5 - 22.3 (65 - 72)
60 - 70	20 (68)	5.4 - 6.8 (42 - 44)
	25 (77)	5.6 - 8.0 (42 - 46)
	30 (86)	11.1 - 14.1 (52 - 57)
	35 (95)	16.7 - 20.3 (62 - 69)
	40 (104)	22.3 - 26.5 (72 - 80)

* Thermometer should be placed at intake unit under RH side of instrument panel.

Ambient air temperature-to-operating pressure table

Ambient air		High-pressure (Discharge side) kPa (kg/cm ² , psi)	Low-pressure (Suction side) kPa (kg/cm ² , psi)
Relative humidity %	Air temperature °C (°F)		
50 - 70	20 (68)	834 - 1,098 (8.5 - 11.2, 121 - 159)	122.6 - 161.8 (1.25 - 1.65, 17.8 - 23.5)
	25 (77)	1,049 - 1,363 (10.7 - 13.9, 152 - 198)	137.3 - 181.4 (1.4 - 1.85, 19.9 - 26.3)
	30 (86)	1,226 - 1,618 (12.5 - 16.5, 178 - 235)	152.0 - 201.0 (1.55 - 2.05, 22.0 - 29.2)
	35 (95)	1,255 - 1,716 (12.8 - 17.5, 182 - 249)	166.7 - 230.5 (1.7 - 2.35, 24.2 - 33.4)
	40 (104)	1,540 - 2,030 (15.7 - 20.7, 223 - 294)	201.0 - 289.3 (2.05 - 2.95, 29.2 - 41.9)

If pressure is not within range, refer to HA-29, "Trouble Diagnoses for Abnormal Pressure".

Trouble Diagnoses for Abnormal Pressure

Whenever system's high or low-side pressure is abnormal, diagnose using a manifold gauge. The marker above the gauge scale in the following table indicates the standard normal pressure range. Since the standard normal pressure, differs from vehicle to vehicle, refer to HA-28 "Ambient air temperature-to-operating pressure table".

Pressure measurements are effective only when ambient temperature is in the range indicated under the Performance Chart.

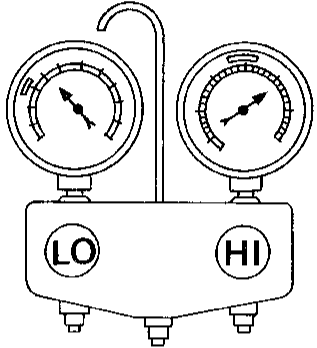
Gauge indication	Refrigerant cycle	Probable cause	Corrective action
<p>Both high and low-pressure sides are too high.</p> <p>A</p>  <p>AC359A</p>	<ul style="list-style-type: none"> ● Pressure is reduced soon after water is splashed on condenser. 	<p>Excessive refrigerant charge in refrigeration cycle.</p>	<p>Reduce refrigerant until specified pressure is obtained.</p>
	<p>Air suction by radiator or cooling fan is insufficient.</p>	<p>Insufficient condenser cooling performance.</p> <p style="text-align: center;">↓</p> <p>① Condenser fins are clogged. ② Improper rotation of cooling fan.</p>	<ul style="list-style-type: none"> ● Clean condenser. ● Check and repair radiator or cooling fan as necessary.
	<ul style="list-style-type: none"> ● Low-pressure pipe is not cold. ● When compressor is stopped high-pressure value quickly drops by approximately 196 kPa (2 kg/cm², 28 psi). It then decreases gradually thereafter. 	<p>Poor heat exchange in condenser. (After compressor operation stops, high-pressure decreases too slowly.)</p> <p style="text-align: center;">↓</p> <p>Air in refrigeration cycle.</p>	<p>Evacuate repeatedly and recharge system.</p>
	<p>Engine tends to overheat.</p>	<p>Engine cooling systems malfunction.</p>	<p>Check and repair each engine cooling system.</p>
	<ul style="list-style-type: none"> ● An area of the low-pressure pipe is colder than near the evaporator outlet. ● Plates are sometimes covered with frost. 	<ul style="list-style-type: none"> ● Excessive liquid refrigerant on low-pressure side. ● Excessive refrigerant discharge flow. ● Expansion valve is open a little compared with the specification. <p style="text-align: center;">↓</p> <p>① Improper thermal valve installation. ② Improper expansion valve adjustment.</p>	<p>Replace expansion valve.</p>

Trouble Diagnoses for Abnormal Pressure (Cont'd)

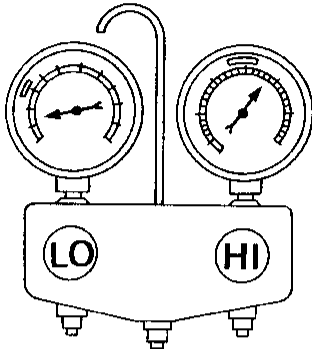
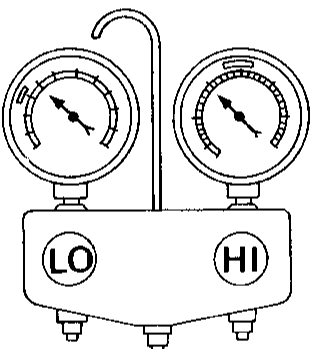
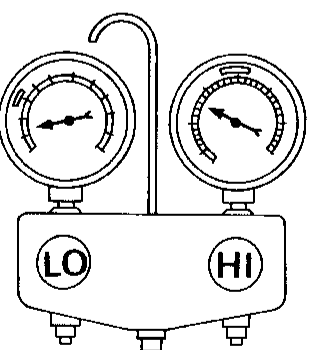
Gauge indication	Refrigerant cycle	Probable cause	Corrective action
<p>High-pressure side is too high and low-pressure side is too low.</p> <p>B</p>  <p>AC360A</p>	<p>Upper side of condenser and high-pressure side are hot, however, liquid tank is not as hot.</p>	<p>High-pressure tube or parts located between compressor and condenser are clogged or crushed.</p>	<ul style="list-style-type: none"> ● Check and repair or replace malfunctioning parts. ● Check lubricant for contamination.
<p>High-pressure side is too low and low-pressure side is too high.</p> <p>C</p>  <p>AC356A</p>	<p>High and low-pressure sides become equal soon after compressor operation stops.</p>	<p>Compressor pressure operation is improper.</p> <p>↓</p> <p>Damaged inside compressor packings.</p>	<p>Replace compressor.</p>
	<p>No temperature difference between high and low-pressure sides.</p>	<p>Compressor discharge capacity does not change. (Compressor stroke is set at maximum.)</p>	<p>Replace compressor.</p>
<p>Both high and low-pressure sides are too low.</p> <p>D</p>  <p>AC353A</p>	<ul style="list-style-type: none"> ● There is a big temperature difference between liquid tank outlet and inlet. Outlet temperature is extremely low. ● Liquid tank inlet and expansion valve are frosted. 	<p>Liquid tank is partly clogged.</p>	<ul style="list-style-type: none"> ● Replace liquid tank. ● Check lubricant for contamination.
	<ul style="list-style-type: none"> ● Temperature of expansion valve inlet is extremely low as compared with areas near liquid tank. ● Expansion valve inlet may be frosted. ● Temperature difference occurs somewhere in high-pressure side. 	<p>High-pressure pipe located between liquid tank and expansion valve is clogged.</p>	<ul style="list-style-type: none"> ● Check and repair malfunctioning parts. ● Check lubricant for contamination.
	<ul style="list-style-type: none"> ● Expansion valve and liquid tank are warm or only cool to the touch. 	<p>Low refrigerant charge.</p> <p>↓</p> <p>Leaking fittings or components.</p>	<ul style="list-style-type: none"> ● Check for refrigerant leaks. Refer to "Checking Refrigerant Leaks", HA-134.

Trouble Diagnoses for Abnormal Pressure (Cont'd)

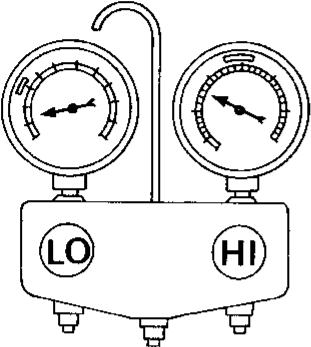
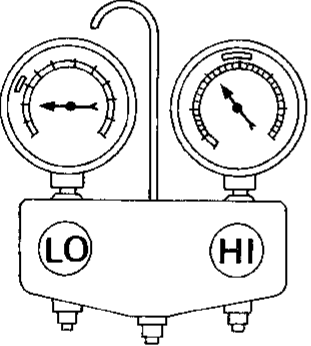
Gauge indication	Refrigerant cycle	Probable cause	Corrective action
<p>Both high and low-pressure sides are too low.</p> <p>D</p>  <p>AC353A</p>	<p>There is a big temperature difference between expansion valve inlet and outlet while the valve itself is frosted.</p> <p>An area of low-pressure pipe is colder than areas near the evaporator outlet.</p> <p>Air flow volume is not enough or is too low.</p>	<p>Expansion valve closed and past the specification.</p> <p style="text-align: center;">↓</p> <p>① Improper expansion valve adjustment.</p> <p>② Malfunctioning thermal valve.</p> <p>③ Outlet and inlet may be clogged.</p> <p>Low-pressure pipe is clogged or crushed.</p> <p>Evaporator is frozen.</p> <p style="text-align: center;">↓</p> <p>Compressor discharge capacity does not change. (Compressor stroke is set at maximum length.)</p>	<ul style="list-style-type: none"> ● Remove foreign particles by using compressed air. ● Check lubricant for contamination. <ul style="list-style-type: none"> ● Check and repair malfunctioning parts. ● Check lubricant for contamination. <p>Replace compressor.</p>
<p>Low-pressure side sometimes becomes negative.</p> <p>E</p>  <p>AC354A</p>	<ul style="list-style-type: none"> ● Air conditioner system does not function and does not cyclically cool the compartment air. ● The system constantly functions for a certain period of time after compressor is stopped and restarted. 	<p>Refrigerant does not discharge cyclically.</p> <p style="text-align: center;">↓</p> <p>Moisture is frozen at expansion valve outlet and inlet.</p> <p style="text-align: center;">↓</p> <p>Water is mixed with refrigerant.</p>	<ul style="list-style-type: none"> ● Replace refrigerant. ● Replace liquid tank.

GI
MA
ME
LC
EG
FE
CL
MT
AT
FA
RA
BR
ST
RS
BT
HA
EL
IX

Trouble Diagnoses for Abnormal Pressure (Cont'd)

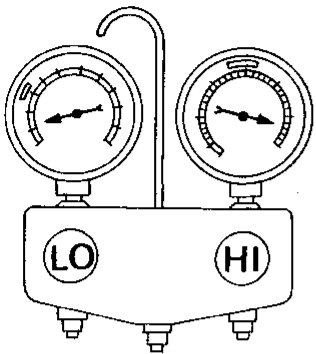
Gauge indication	Refrigerant cycle	Probable cause	Corrective action
<p>Low-pressure side becomes negative.</p> <p>F</p>  <p>AC362A</p>	<p>Liquid tank or front/rear side of expansion valve's pipe is frosted or dewed.</p>	<p>High-pressure side is closed and refrigerant does not flow.</p> <p style="text-align: center;">↓</p> <p>Expansion valve or liquid tank is frosted.</p>	<p>Leave the system at rest until no frost is present. Start it again to check whether or not the problem is caused by water or foreign particles.</p> <ul style="list-style-type: none"> ● If water is the cause, initial cooling is okay. Then the water freezes causing a blockage. ● Replace refrigerant. ● If due to foreign particles, remove expansion valve and remove particles with dry, compressed air (not shop air). ● If either of the above methods cannot correct the problem, replace expansion valve. ● Replace liquid tank. ● Check lubricant for contamination.

Harness Layout

Engine compartment

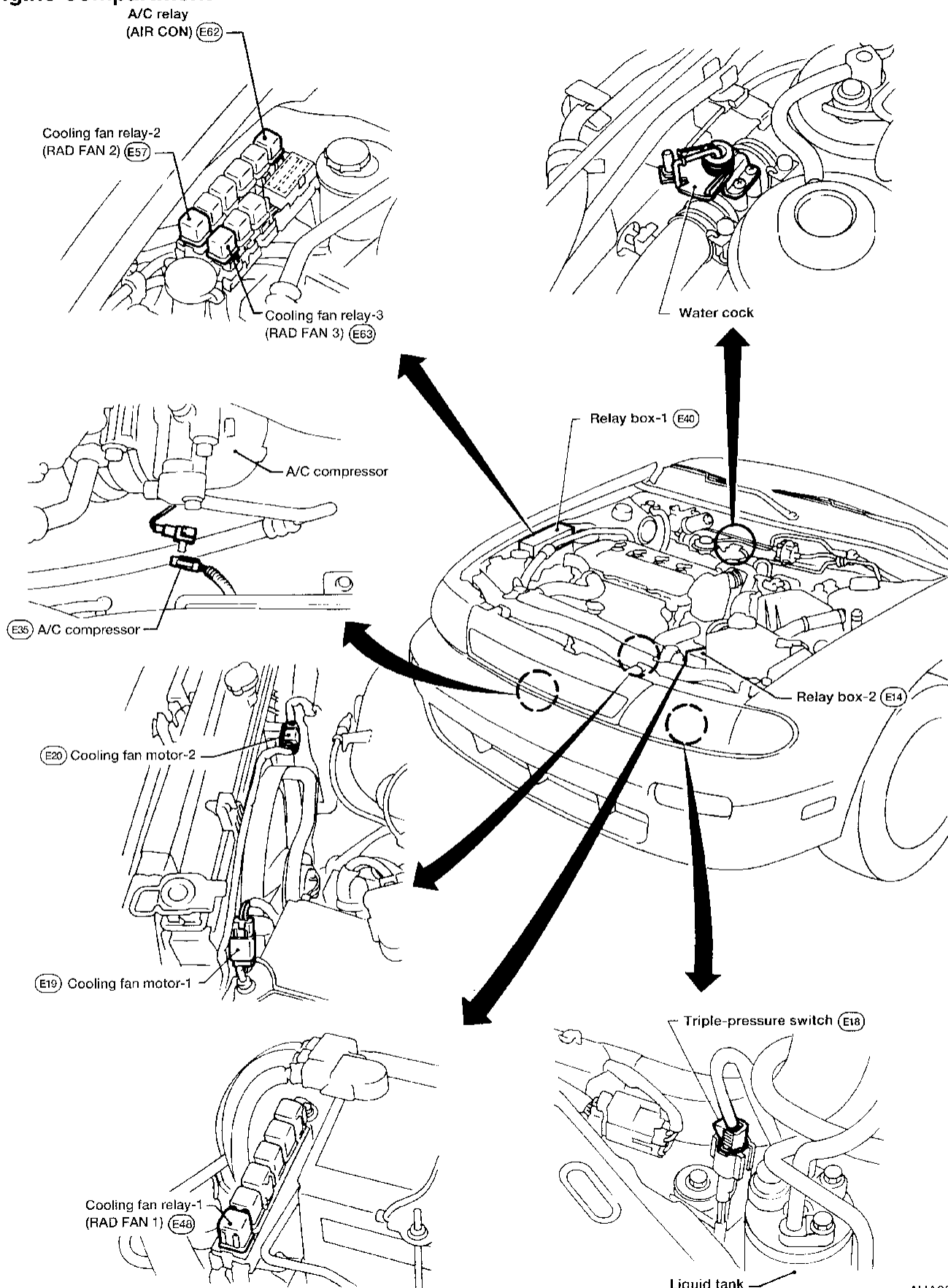

GI
MA
EM
LC
FC
FE
CL
MT
AT
FA
RA
BR
ST
RS
BT

HA

EL
DX

Harness Layout (Cont'd)

Passenger compartment

A Push control unit

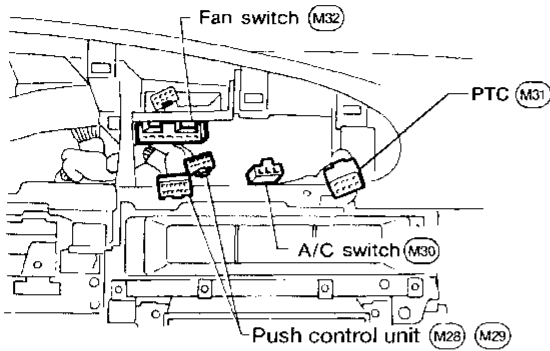

B Mode door motor

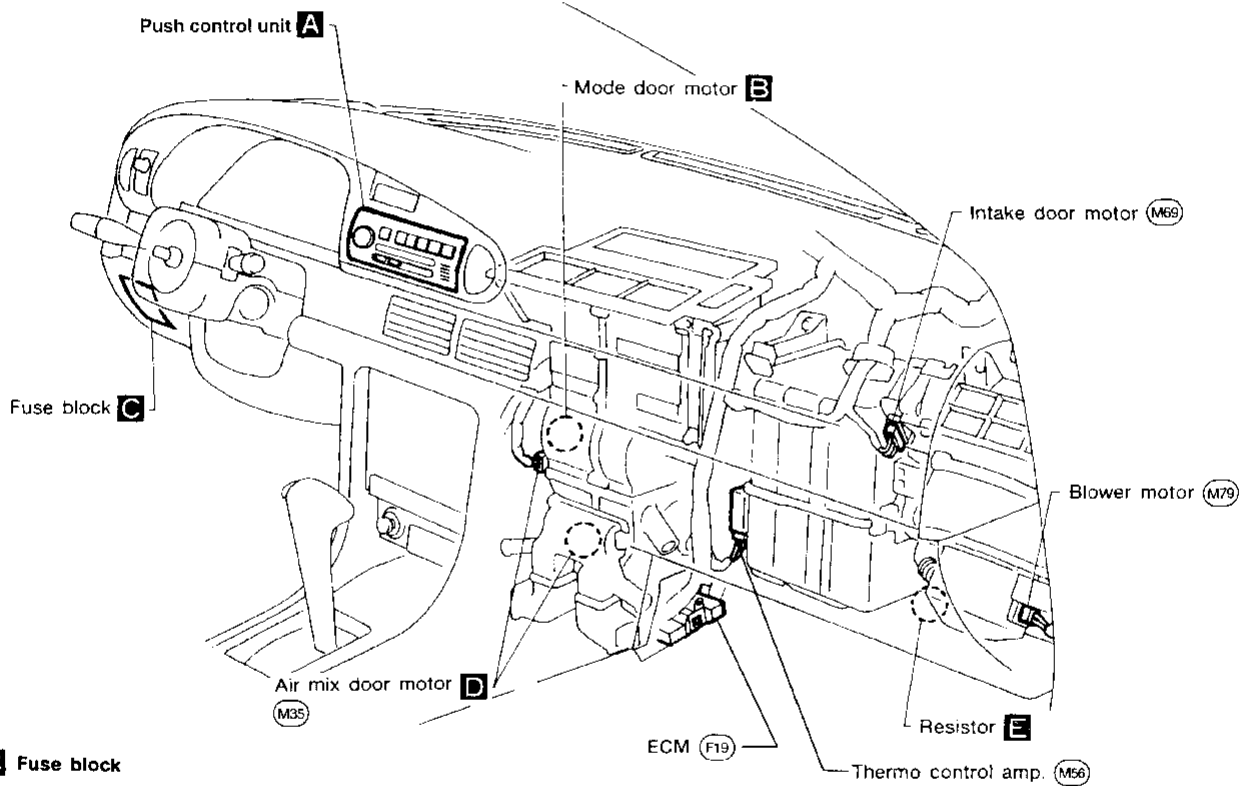
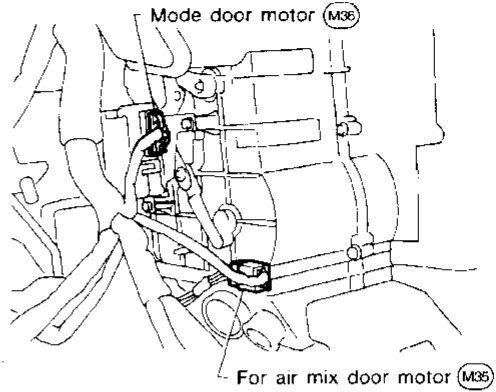

C Fuse block

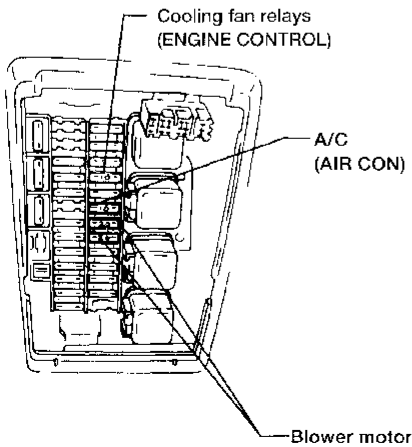

D Air mix door motor

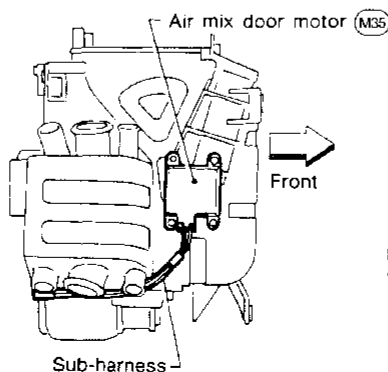

E Resistor

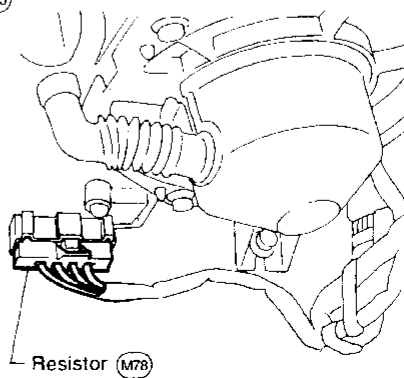

Circuit Diagram

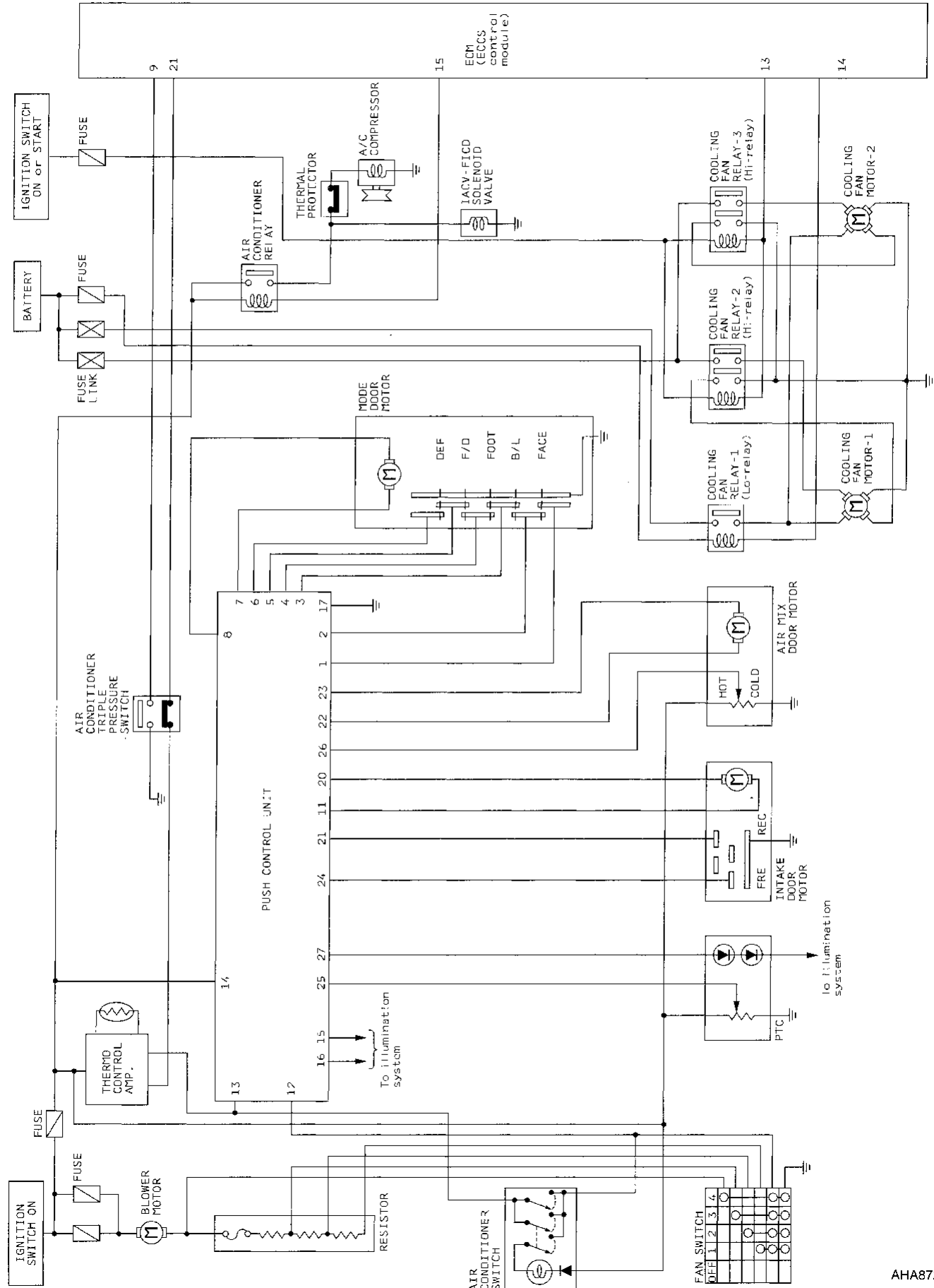

GA
HA
EM
LC
EC
FE
CL
MT
AT
FA
RA
DR
GT
RS
BT

HA

EL
IDX

Wiring Diagram -HEATER-

HA-HEATER-01

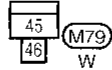
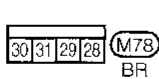
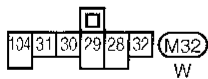
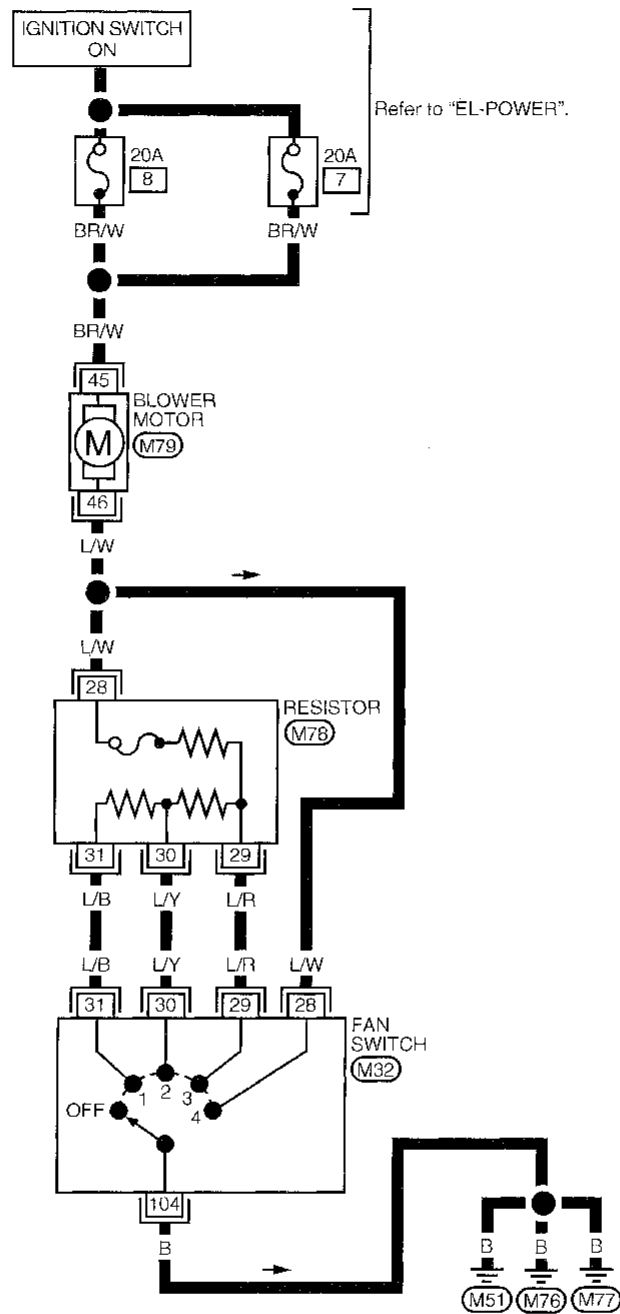

Wiring Diagram -A/C, M-

HA-A/C,M-01

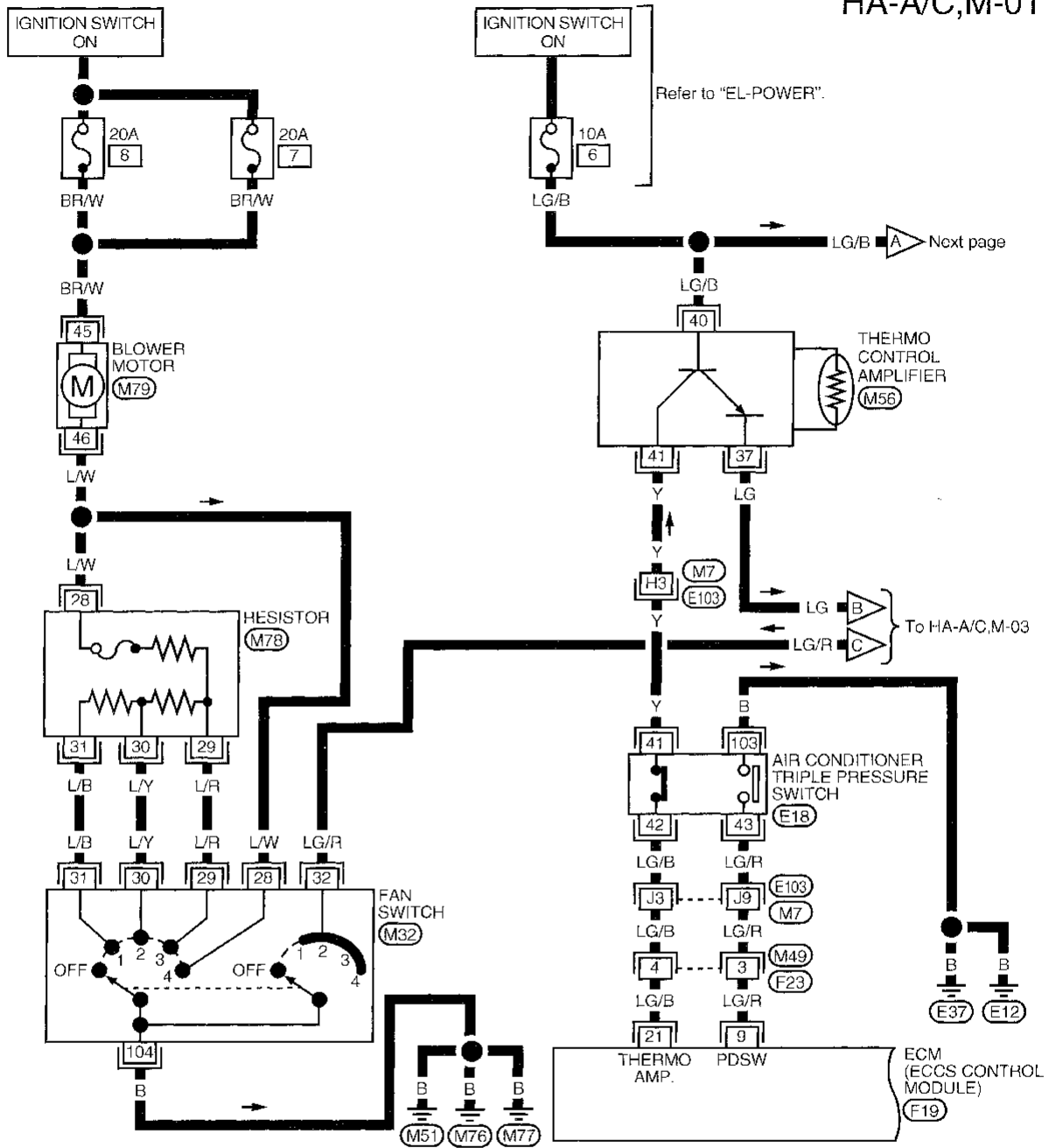

Refer to "EL-POWER".

Next page

To HA-A/C,M-03

Refer to last page (Foldout page).

(M7), (E103)

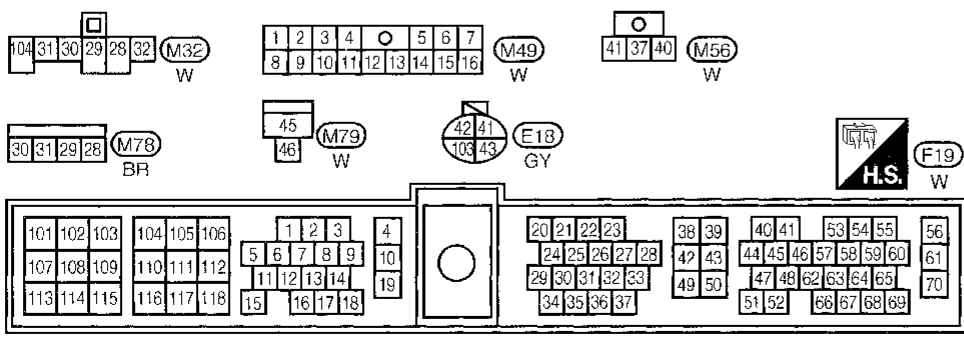

CI
MA
EM
LG
EC
FE
CL
MT
A
FA
RA
BR
ST
ES
ET

HA
EL
IDX

Wiring Diagram -A/C, M- (Cont'd)

HA-A/C,M-02

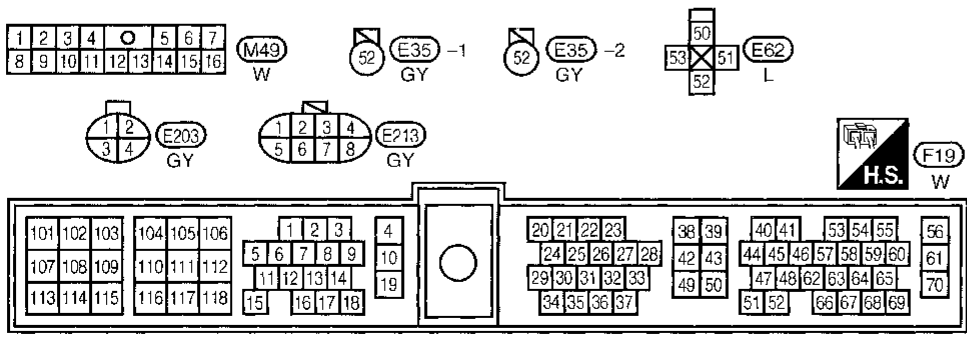
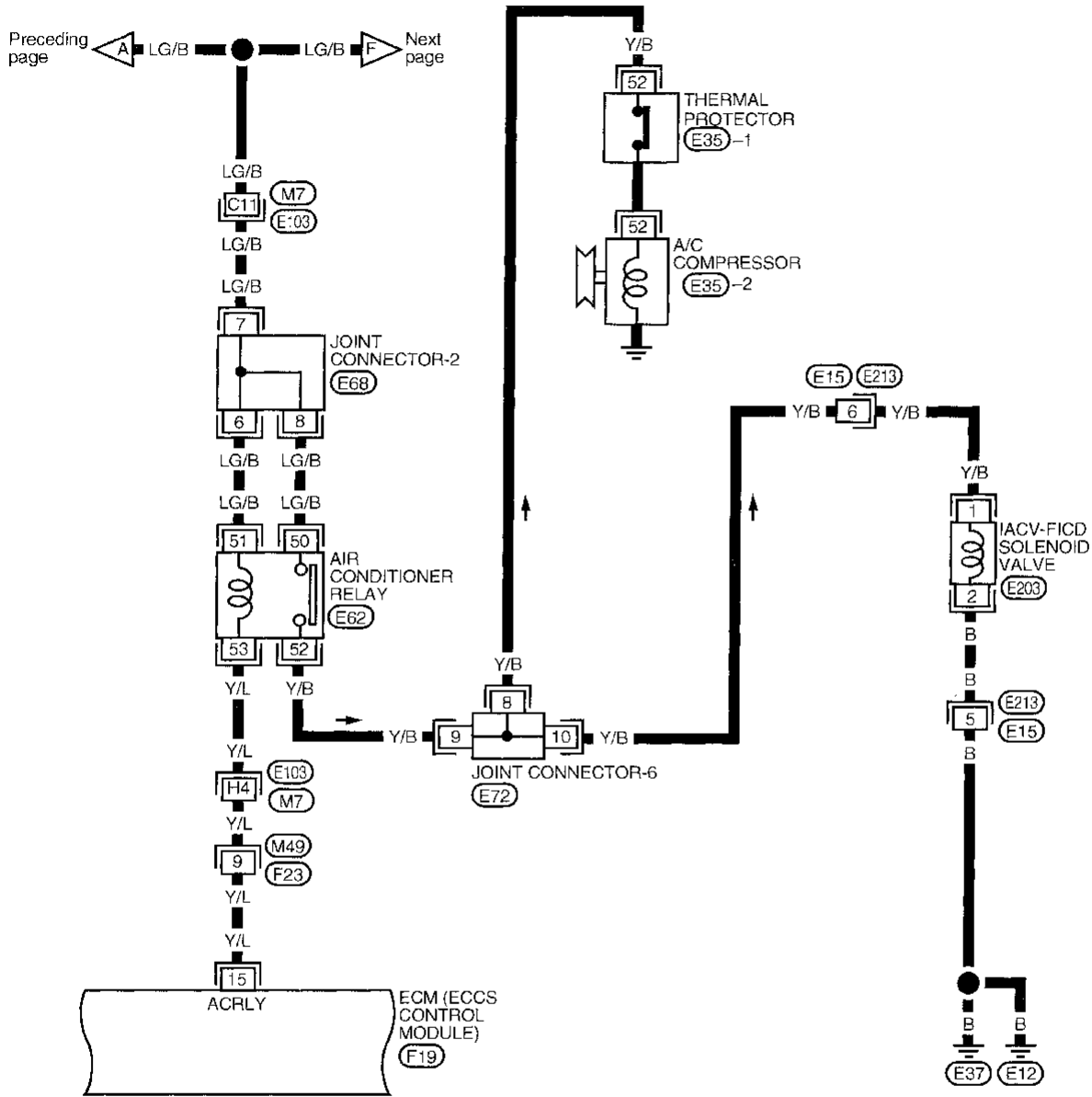

Refer to last page (Foldout page).

- M7, E103
- E68
- E72

Wiring Diagram -A/C, M- (Cont'd)

HA-A/C,M-03

Preceding page LG/B Next page

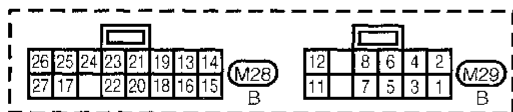
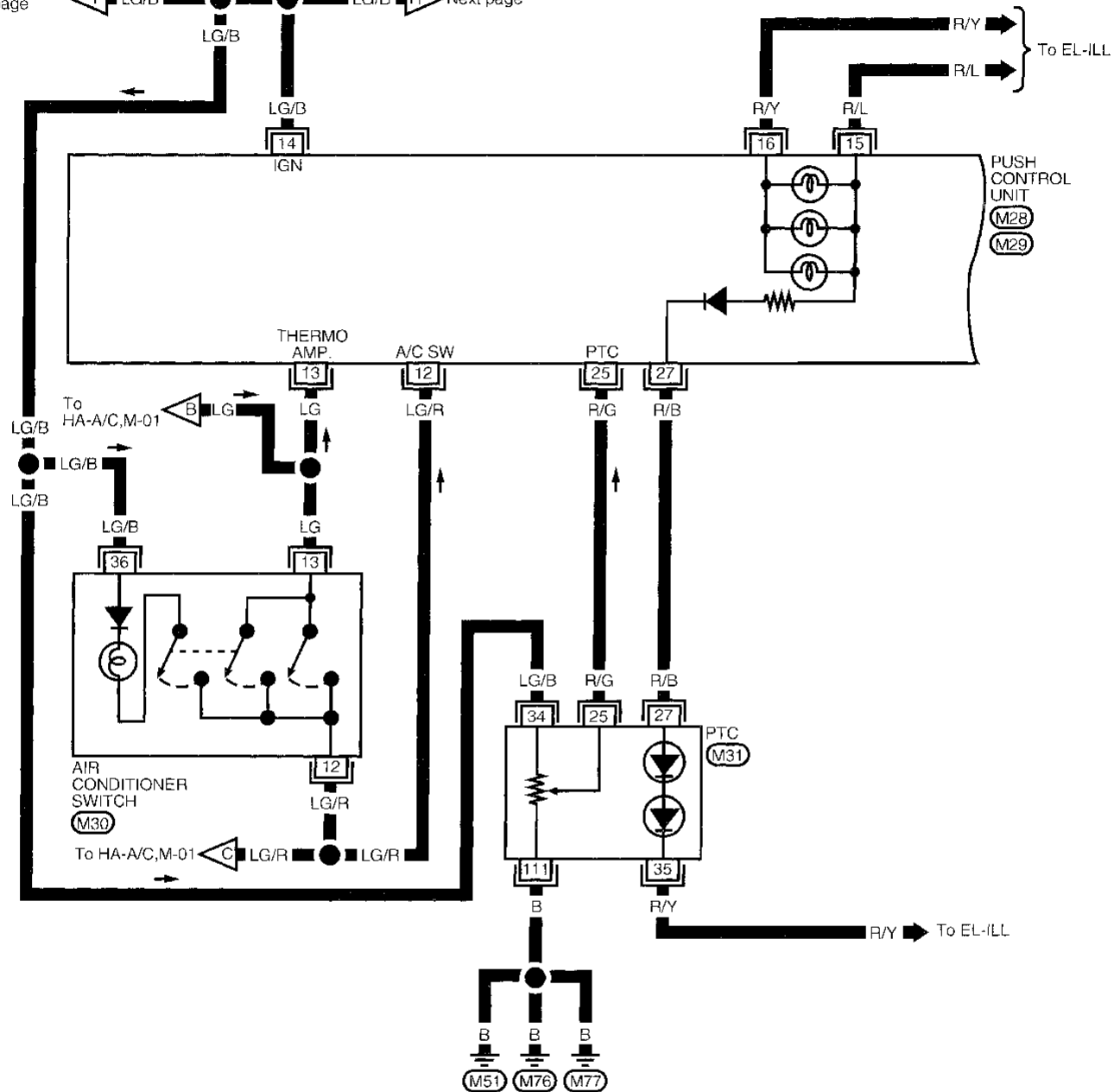

CI
MA
EM
LG
EG
FE
QL
MT
AT
FA
RA
BR
ST
RS
BT

HA

EL

IDX

Wiring Diagram -A/C, M- (Cont'd)

HA-A/C,M-04

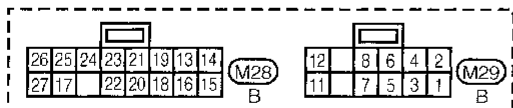
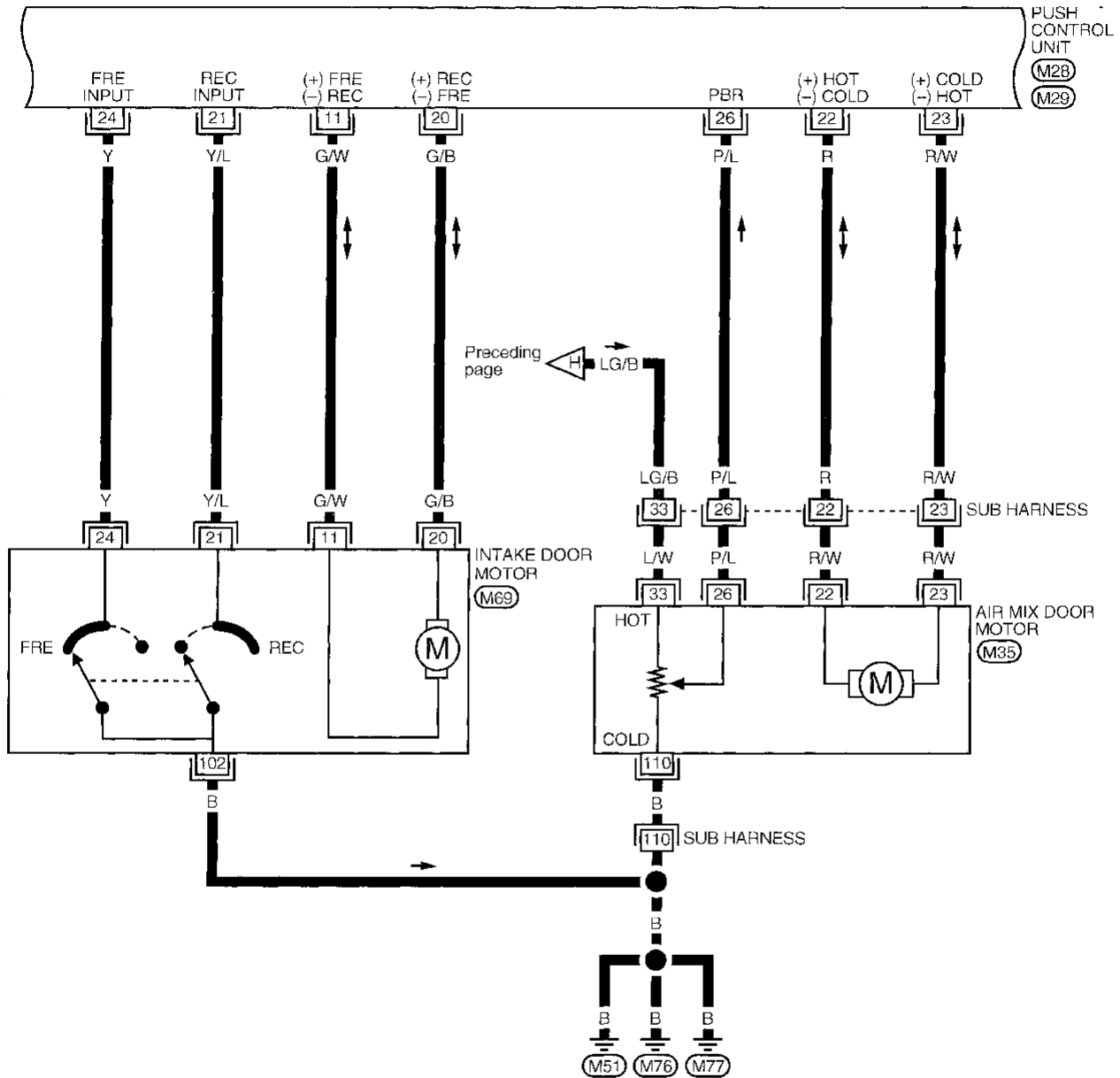

Wiring Diagram -A/C, M- (Cont'd)

HA-A/C,M-05

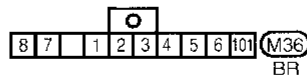
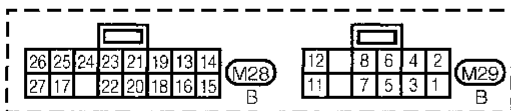
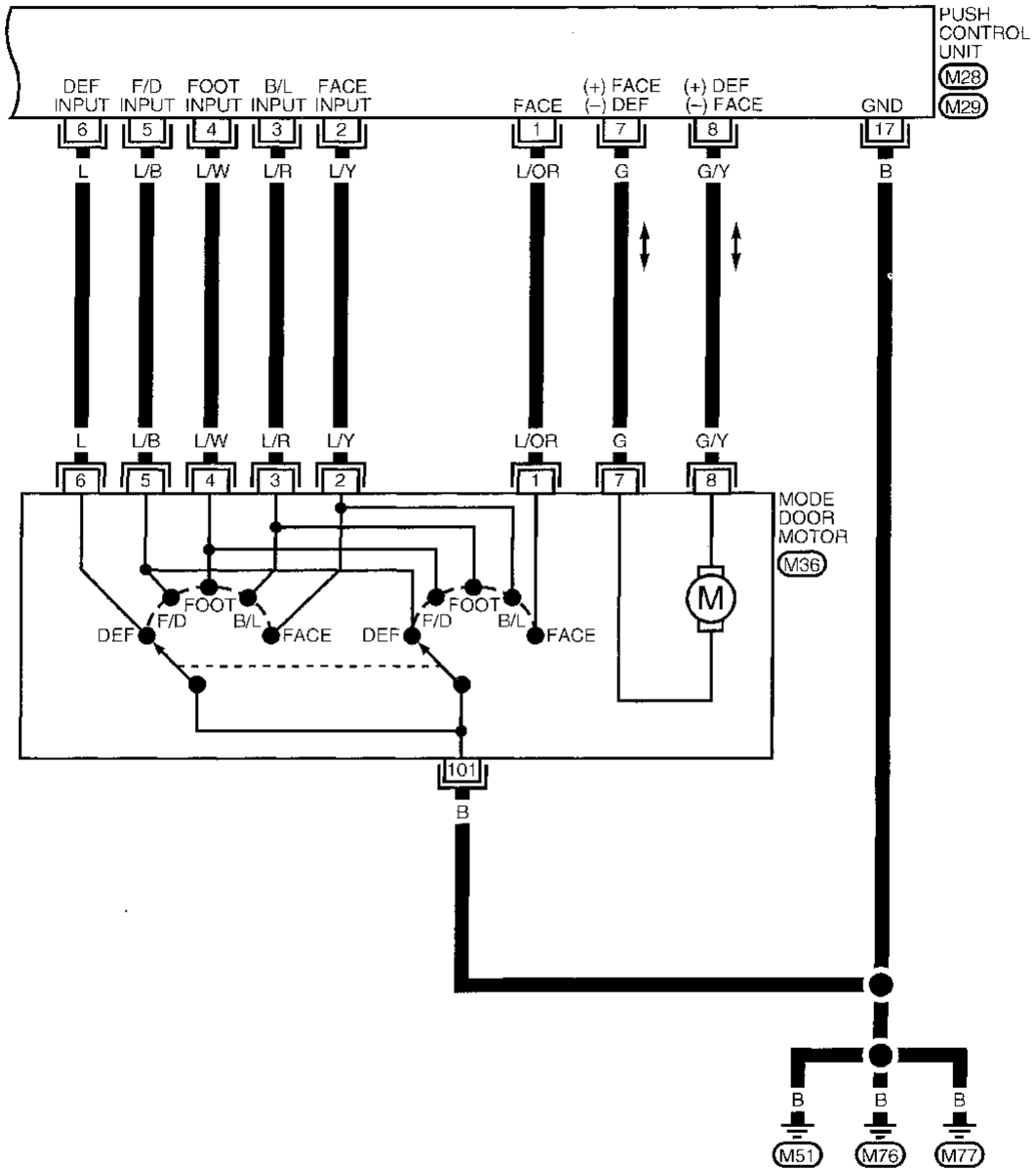

GI
NA
EW
LC
EC
FE
CL
MT
AT
EA
RA
BR
ST
RS
BT

HA

EL
DX

Wiring Diagram -A/C, M- (Cont'd)

HA-A/C,M-06

Refer to "EL-POWER".

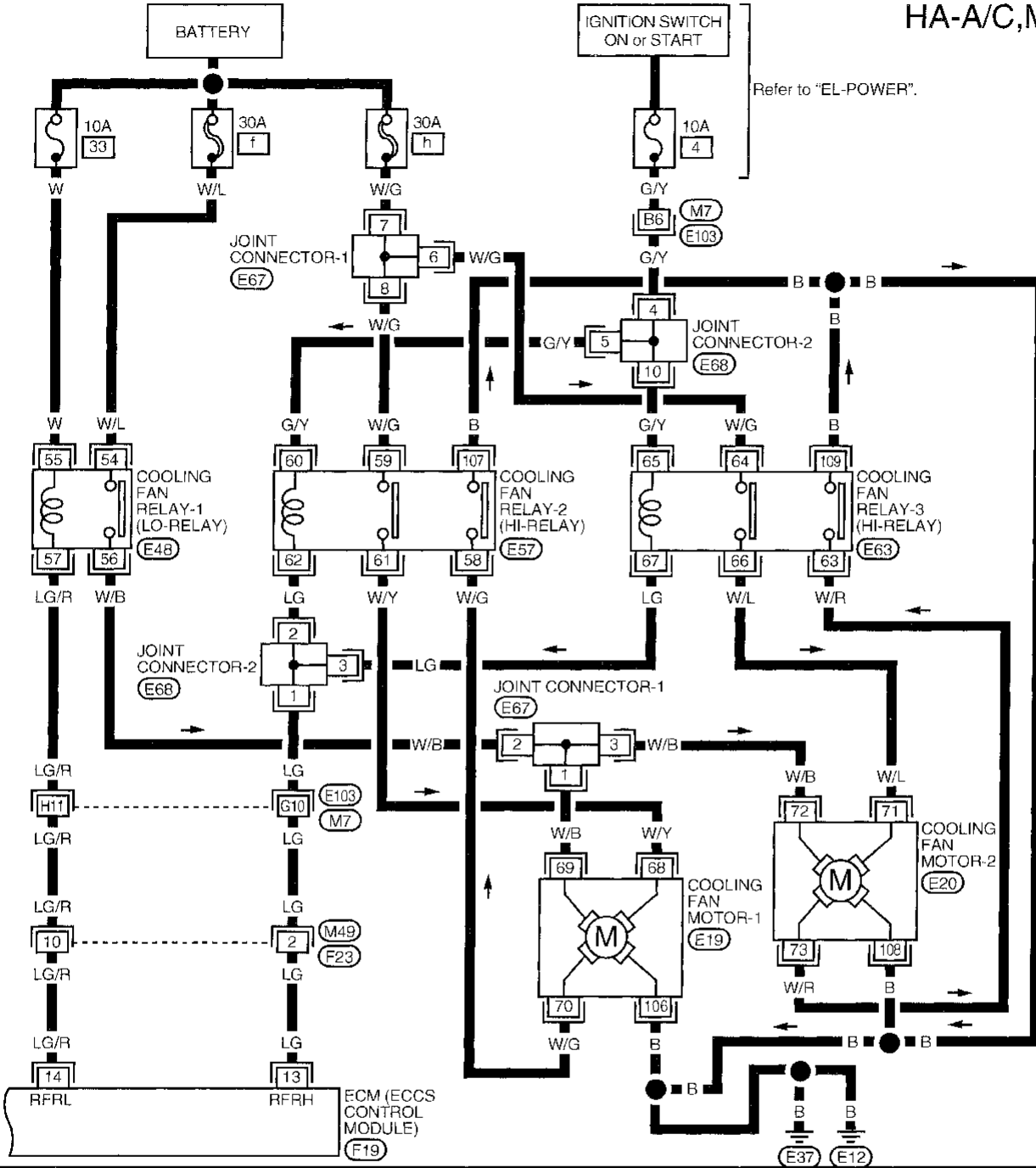

Refer to last page (Foldout page).

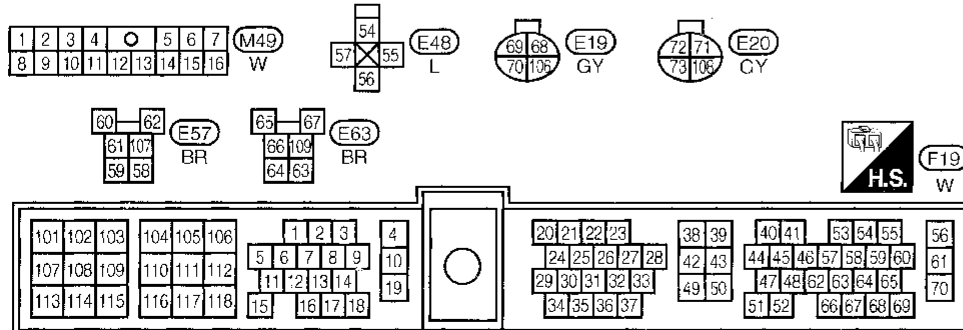

Main Power Supply and Ground Circuit Check

POWER SUPPLY CIRCUIT CHECK

Check power supply circuit for air conditioner system.

Refer to EL section (“Wiring Diagram”, “POWER SUPPLY ROUTING”).

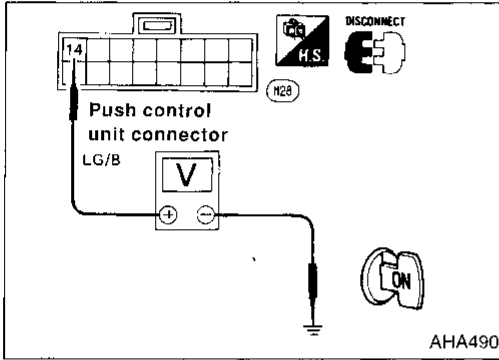

PUSH CONTROL UNIT CHECK

Check power supply circuit for push control unit with ignition switch ON.

1. Disconnect push control unit harness connector.
2. Connect voltmeter from harness side.
3. Measure voltage across terminal No. ⑭ and body ground.

Voltmeter terminal		Voltage
⊕	⊖	
⑭	Body ground	Approx. 12V

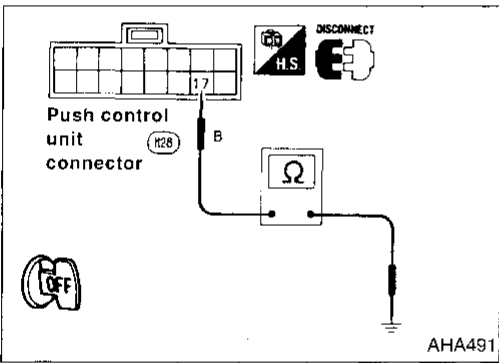

Check body ground circuit for push control unit with ignition switch OFF.

1. Disconnect push control unit harness connector.
2. Connect ohmmeter from harness side.
3. Check for continuity between terminal No. ⑰ and body ground.

Ohmmeter terminal		Continuity
⊕	⊖	
⑰	Body ground	Yes

GI
MA
EM
LC
EC
FE
CL
MT
AT
FA
FA
BR
ST
RS
BT
HA
EL
IDX

	INCIDENT	Flow chart No.
1	Fan fails to rotate.	1
2	Fan does not rotate at 1-speed.	2
3	Fan does not rotate at 2-speed.	3
4	Fan does not rotate at 3-speed.	4
5	Fan does not rotate at 4-speed.	5

Diagnostic Procedure 1

SYMPTOM: Blower motor does not rotate.

- Perform PRELIMINARY CHECK 2 before referring to the following flow chart.

Check if blower motor rotates properly at each fan speed.
Conduct check as per flow chart at left.

2 3 4 5
(Go to next page.)

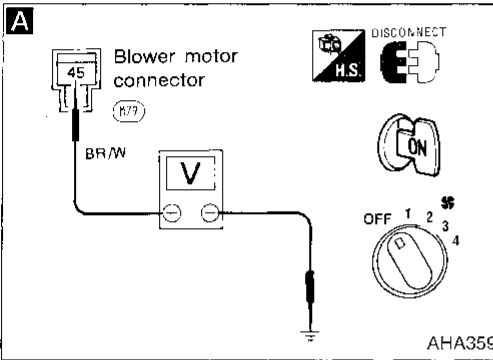

A CHECK POWER SUPPLY FOR BLOWER MOTOR.
Disconnect blower motor harness connector.
Do approx. 12 volts exist between blower motor harness terminal No. (45) and body ground?

No
Check 20A fuses at fuse block.
Refer to EL section ("Wiring Diagram", "POWER SUPPLY ROUTING").

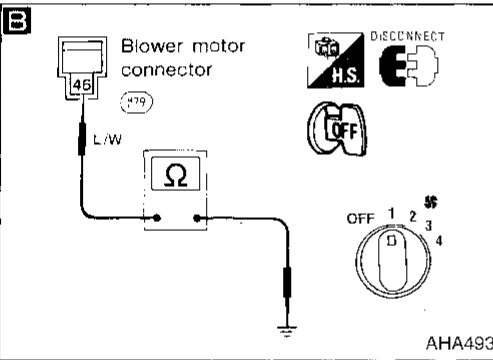

B CHECK CIRCUIT CONTINUITY BETWEEN BLOWER MOTOR HARNESS TERMINAL NO. (46) AND BODY GROUND.

OK
CHECK BLOWER MOTOR.
Refer to HA-55.

NG
Replace blower motor.

Reconnect blower motor harness connector.

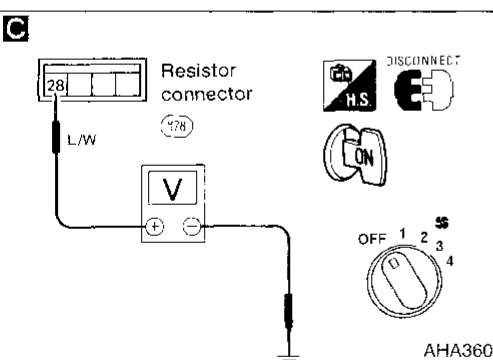

C CHECK BLOWER MOTOR CIRCUIT BETWEEN BLOWER MOTOR AND RESISTOR.
Do approx. 12 volts exist between resistor harness terminal No. (28) and body ground?

No
Disconnect blower motor and resistor harness connectors.

D CHECK CIRCUIT CONTINUITY BETWEEN BLOWER MOTOR HARNESS TERMINAL NO. (46) AND RESISTOR HARNESS TERMINAL NO. (28).
Note

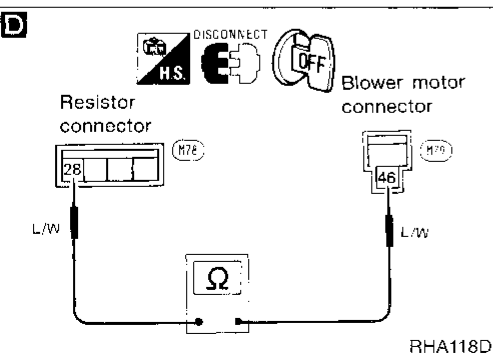

(A)

(Go to next page.)

Note:
If the result is NG or No after checking circuit continuity, repair harness or connector.

Diagnostic Procedure 1 (Cont'd)

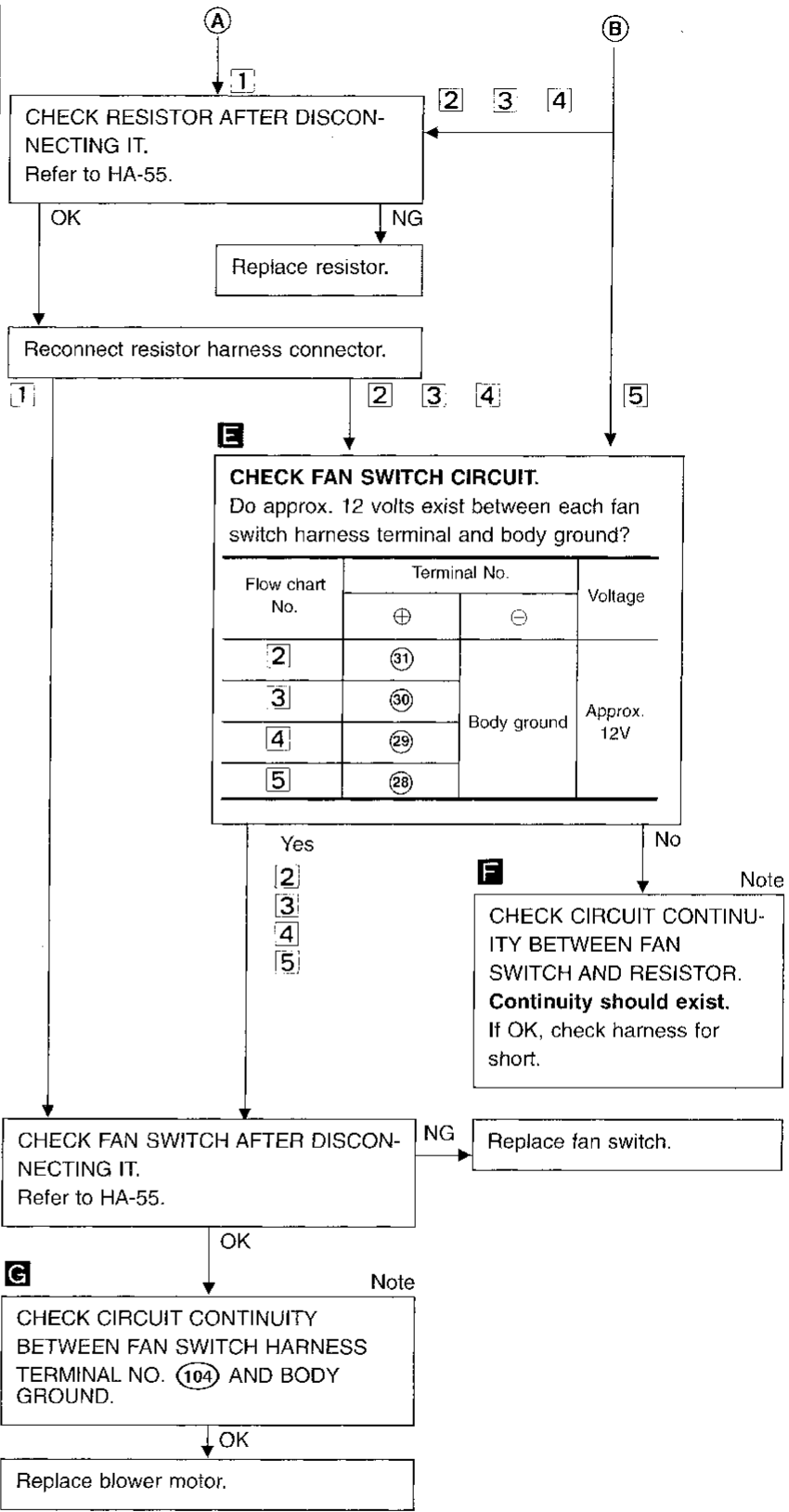
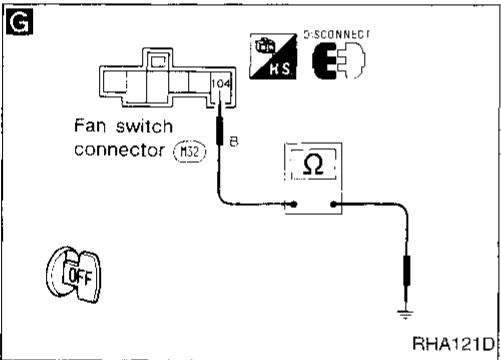
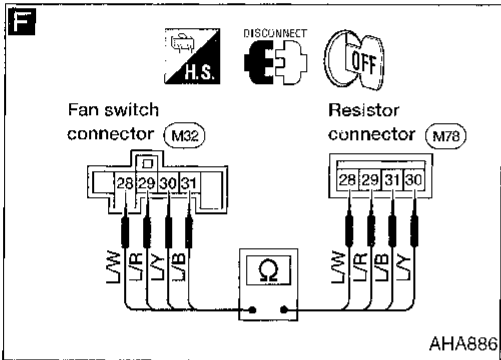
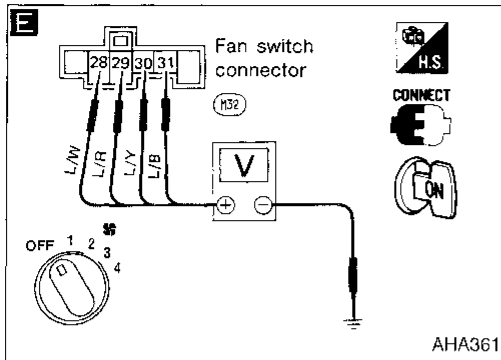

GI
MA
EM
LC
EC
FE
CL
MT
AT
FA
RA
BR
ST
RS
BT
HA
EL
IDX

Note:
If the result is NG or No after checking circuit continuity, repair harness or connector.

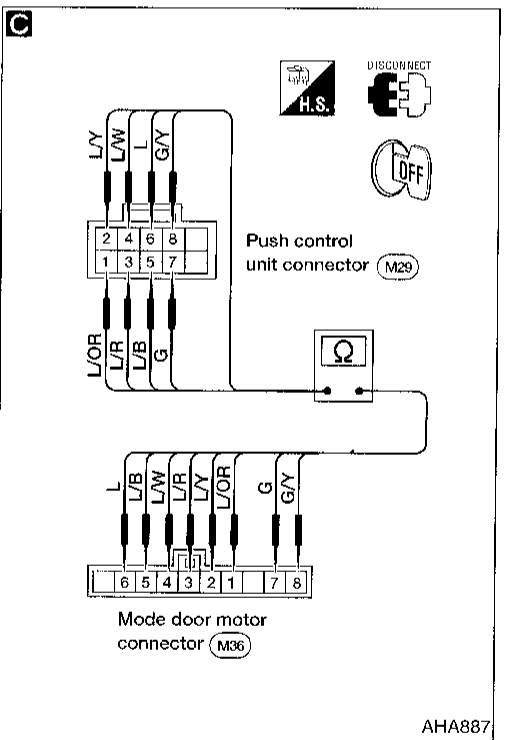
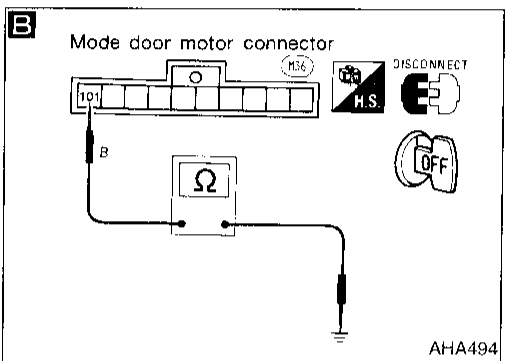
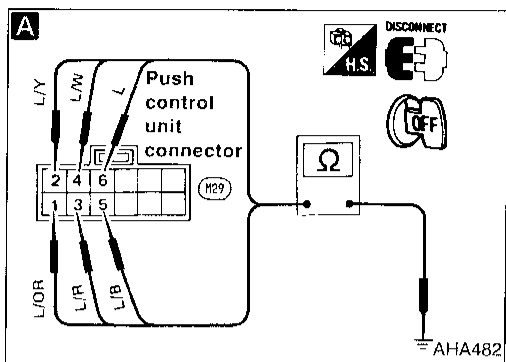

Diagnostic Procedure 2

SYMPTOM: Air outlet does not change.

- Perform PRELIMINARY CHECK 4, then Main Power Supply and Ground Circuit Check before referring to the flow chart below.

A CHECK MODE DOOR MOTOR POSITION SWITCH.

- Press FACE switch ON with ignition switch ON.
- Turn ignition switch OFF.
Disconnect push control unit connector.
- Check for continuity between terminal ① or ② of push control unit harness connector and body ground.
- Using above procedures, check for continuity in any other mode, as indicated in chart.

Mode switch	Terminal No.		Continuity
	⊕	⊖	
FACE	① or ②	Body ground	Yes
B/L	② or ③		
FOOT	③ or ④		
F/D	④ or ⑤		
DEF	⑤ or ⑥		

OK

CHECK SIDE LINK.
Refer to HA-56.

NG
Disconnect mode door motor harness connector.

B CHECK BODY GROUND CIRCUIT FOR MODE DOOR MOTOR.
Does continuity exist between mode door motor harness terminal No. ⑩① and body ground?

Yes

C Check circuit continuity between each terminal on push control unit and on mode door motor.

Push control unit	Terminal No.		Continuity
	⊕	⊖	
①	①	Yes	
②	②		
③	③		
④	④		
⑤	⑤		
⑥	⑥		
⑦	⑦		
⑧	⑧		

If OK, check harness for short.

OK

A

(Go to next page.)

Note:

If the result is NG or No after checking circuit continuity, repair harness or connector.

Diagnostic Procedure 2 (Cont'd)

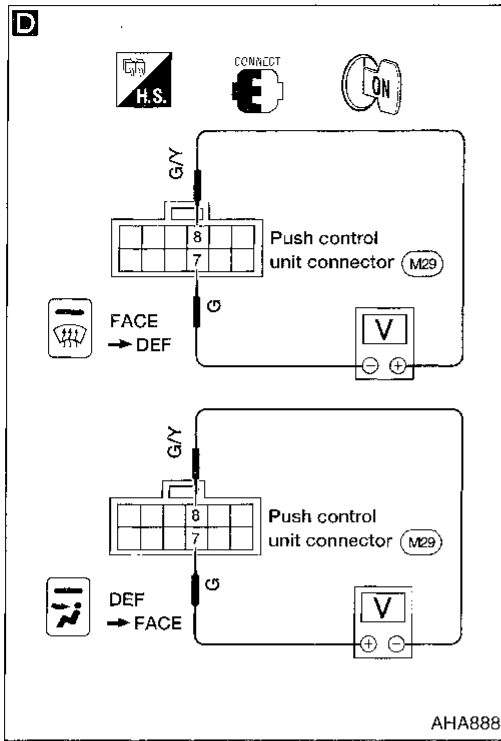

A

Reconnect push control unit and mode door motor harness connectors.

D

CHECK FOR OUTPUT OF PUSH CONTROL UNIT.
 Change the mode from FACE to DEF, or from DEF to FACE. Do approx. 12 volts exist between push control unit harness terminals ⑦ and ⑧ in both cases?

Terminal No.		Mode door motor	
⑦	⑧	Mode door operation	Direction of linkage rotation
-	-	Stop	Stop
-	+	FACE → DEF	Clockwise
+	-	DEF → FACE	Counterclockwise

NG → Replace push control unit.

OK ↓

Replace mode door motor.

GI
 MA
 EM
 LC
 EC
 FE
 CL
 MT
 AT
 FA
 RA
 BR
 ST
 RS
 ET
 HA
 EL
 IDX

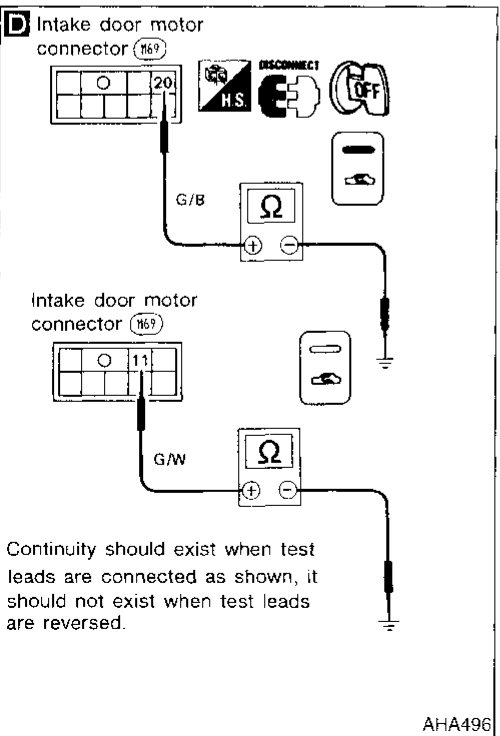
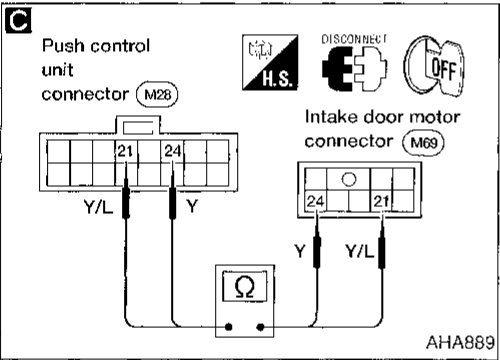
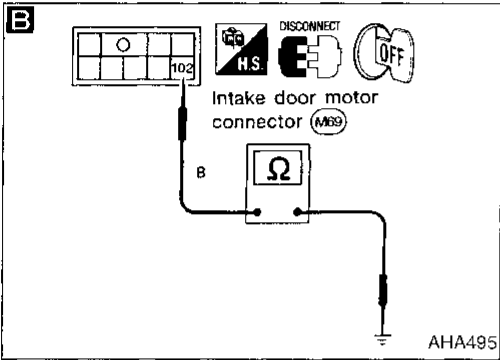
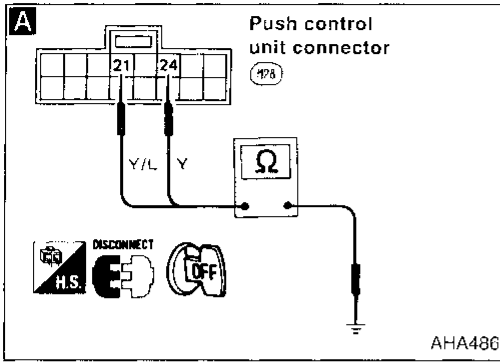

Diagnostic Procedure 3

SYMPTOM: Intake door does not change in FACE, B/L or FOOT mode.

- Perform PRELIMINARY CHECK 1, then Main Power Supply and Ground Circuit Check before referring to the flow chart below.

A

CHECK INTAKE DOOR MOTOR POSITION SWITCH.

1. Press REC switch ON with ignition switch ON.
2. Turn ignition switch OFF.
3. Check if continuity exists between terminal No. ②① of push control unit harness connector and body ground.
4. Using above procedures, check for REC switch OFF position as indicated in chart.

REC switch	Terminal No.		Continuity
	⊕	⊖	
ON	②①	Body ground	Yes
OFF	②④	Body ground	Yes

If OK, check harness for short.

NG → Disconnect intake door motor harness connector.

B Note

CHECK BODY GROUND CIRCUIT FOR INTAKE DOOR MOTOR.

Does continuity exist between intake door motor harness terminal No. ⑩② and body ground?

Yes → **C** Note

C Check circuit continuity between push control unit harness terminal No. ②① (②④) and intake door motor harness terminal No. ②① (②④). **Continuity should exist.** If OK, check harness for short.

OK → Reconnect push control unit and intake door motor harness connector.

D

CHECK BODY GROUND CIRCUIT FOR INTAKE DOOR MOTOR.

- Press REC switch ON. Does continuity exist between intake door motor harness terminal No. ②① and body ground? If OK, check harness for short.
- Press REC switch OFF. Does continuity exist between intake door motor harness terminal No. ①① and body ground? If OK, check harness for short.

Yes → Replace intake door motor.

No → Replace push control unit.

Note:
If the result is NG or No after checking circuit continuity, repair harness or connector.

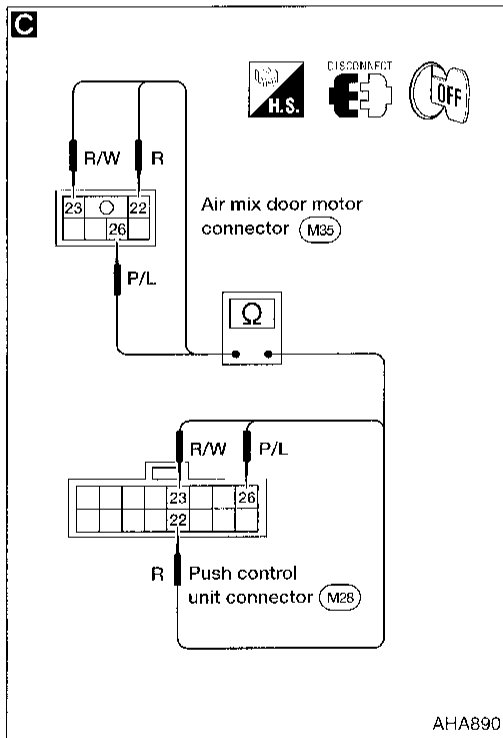
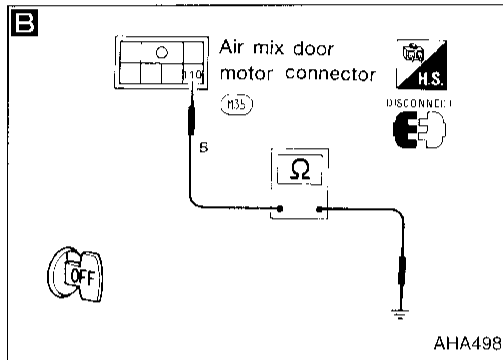
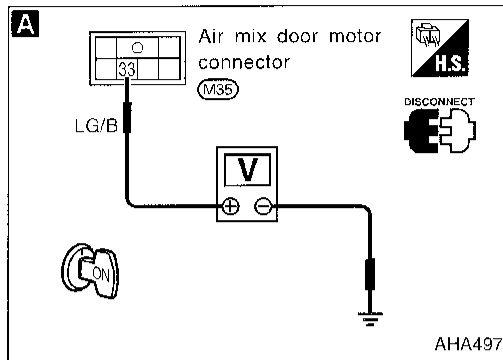

Diagnostic Procedure 4

SYMPTOM: Air mix door does not change.

Perform Main Power Supply and Ground Circuit Check before referring to the following chart.

A

CHECK POWER SUPPLY FOR AIR MIX DOOR MOTOR.
 Disconnect air mix door motor harness connector.
 Do approx. 12V exist between air mix door motor harness terminal No. (33) and body ground?

No → CHECK POWER SUPPLY CIRCUIT AND 10A FUSE AT FUSE BLOCK. Refer to EL section ("Wiring Diagram", "POWER SUPPLY ROUTING").

Yes

B Note

Check circuit continuity between air mix door motor harness terminal No. (110) and body ground.

OK

Disconnect push control unit harness connector.

C Note

Check circuit continuity between each terminal on push control unit and air mix door motor.

Terminal No.		Continuity
Air mix door motor	Push control unit	
(22)	(22)	Yes
(23)	(23)	
(26)	(26)	

If OK, check harness for short.

OK

Reconnect push control unit and air mix door motor harness connector.

A

(Go to next page.)

Note:
 If the result is NG or No after checking circuit continuity, repair harness or connector.

GI
 MA
 EM
 LG
 EG
 FE
 CI
 ME
 AT
 HA
 PA
 BR
 ST
 RS
 BT
 HA
 EL
 IDX

Diagnostic Procedure 4 (Cont'd)

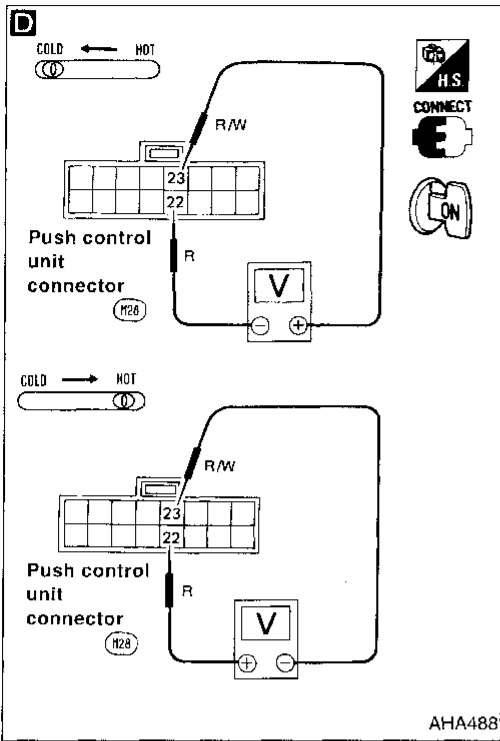

D

CHECK FOR PUSH CONTROL UNIT OUTPUT.
 Do approx. 12 volts exist between push control unit harness terminal No. ②② and ②③ when temperature lever is slid from HOT to COLD or when temperature lever is slid from COLD to HOT?

Terminal No.		Air mix door motor	
②②	②③	Air mix door operation	Direction of linkage rotation
⊖	⊕	HOT → COLD	Clockwise
⊕	⊖	COLD → HOT	Counterclockwise
⊖	⊖	STOP	STOP

No → Replace push control unit.

Yes →

D

CHECK AIR MIX DOOR.
 Refer to HA-57.

OK →

Replace air mix door motor.

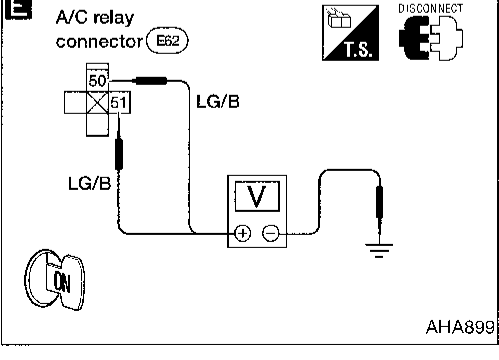
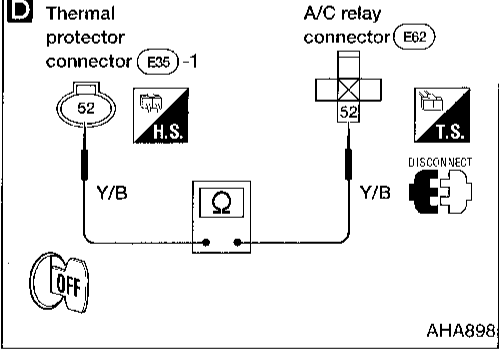
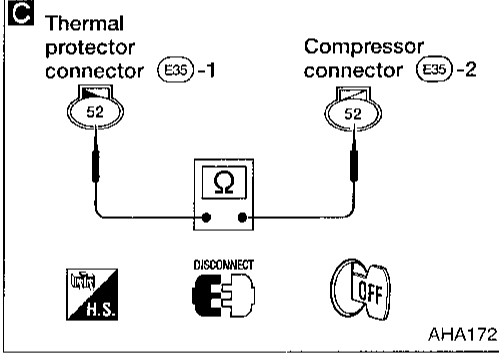
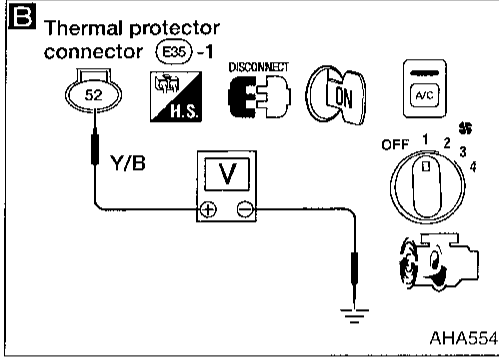
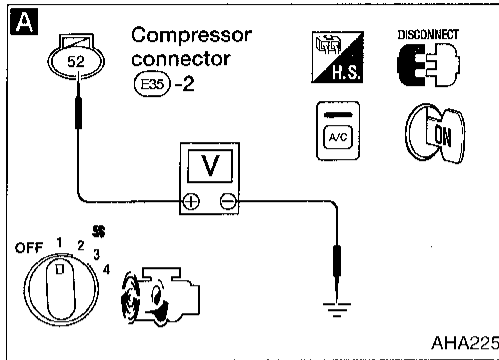

Diagnostic Procedure 5

SYMPTOM: Magnet clutch does not engage when A/C switch and fan switch are ON.

- Perform PRELIMINARY CHECK 2 before referring to the following chart.

```

    graph TD
      A["A  
CHECK POWER SUPPLY FOR COMPRESSOR.  
Disconnect compressor harness connector. Do approx. 12 volts exist between compressor harness terminal No. 52 and body ground?"]
      B["B  
CHECK POWER SUPPLY FOR THERMAL PROTECTOR.  
Disconnect thermal protector harness connector. Do approx. 12V exist between thermal protector harness terminal No. 52 and body ground?"]
      C["C  
CHECK THERMAL PROTECTOR.  
Check circuit continuity between thermal protector harness terminal No. 52 and compressor harness terminal No. 52. Continuity should exist. If OK, check harness for short."]
      D["D  
Disconnect A/C relay.  
D  
Check circuit continuity between A/C relay harness terminal No. 52 and thermal protector harness terminal No. 52. Continuity should exist. If OK, check harness for short."]
      E["E  
CHECK POWER SUPPLY FOR A/C RELAY.  
Do approx. 12 volts exist between A/C relay harness terminals 50, 51 and body ground?"]
      F["F  
CHECK POWER SUPPLY CIRCUIT AND 10A FUSE AT FUSE BLOCK.  
Refer to EL section (\"Wiring Diagram\", \"POWER SUPPLY ROUTING\")."]
      G["G  
CHECK A/C RELAY AFTER DISCONNECTING IT. Refer to HA-56."]
      H["Reconnect A/C relay."]
      I["Replace magnet clutch. Refer to HA-142."]
      J["Replace thermal protector."]
      K["Replace A/C relay."]
      L["(A) (Go to next page.)"]

      A -- Yes --> I
      A -- No --> B
      B -- Yes --> C
      B -- No --> D
      C -- NG --> J
      C -- OK --> D
      D -- OK --> E
      D -- NG --> F
      E -- No --> F
      E -- Yes --> G
      F --> L
      G -- NG --> K
      G -- OK --> H
      H --> L
  
```

Note: If the result is NG or No after checking circuit continuity, repair harness or connector.

Diagnostic Procedure 5 (Cont'd)

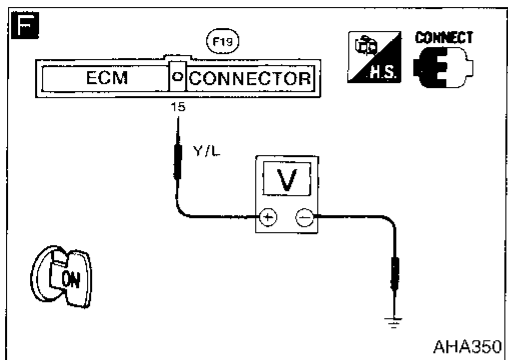

F
CHECK COIL SIDE CIRCUIT OF A/C RELAY.
 Do approx. 12 volts exist between ECM (ECCS control module) harness terminal No. (15) and body ground?
 (For terminal arrangement, refer to HA-38.)

G Note
 Check circuit continuity between A/C relay harness terminal No. (53) and ECM (ECCS control module) harness terminal No. (15).
 (For terminal arrangement, refer to HA-37.)
Continuity should exist.
 If OK, check harness for short.

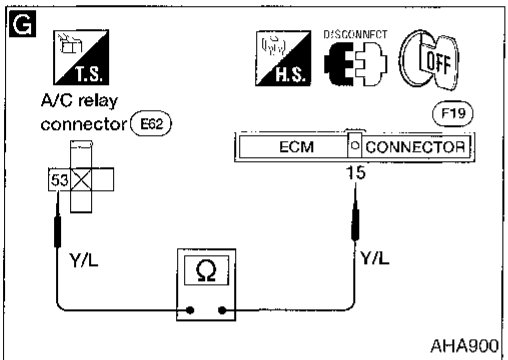

G
CHECK COIL SIDE CIRCUIT OF A/C RELAY CONTROLLED BY ECM (ECCS control module).
 Do more than 8 volts exist between ECM (ECCS control module) harness terminal No. (21) and body ground?
 (For terminal arrangement, refer to HA-38.)

No
 CHECK ECM (ECCS control module).
 Refer to EC section ("TROUBLE DIAGNOSIS FOR DTC 31").

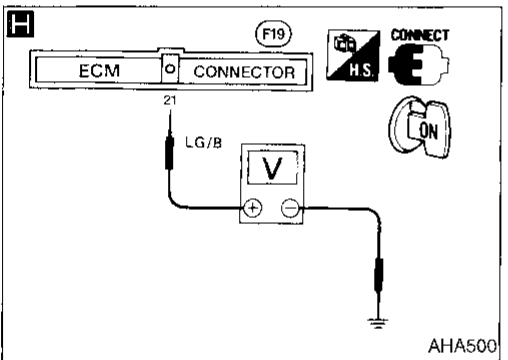

H
CHECK TRIPLE-PRESSURE SWITCH CIRCUIT BETWEEN TRIPLE-PRESSURE SWITCH AND ECM (ECCS control module.)
 Disconnect triple-pressure switch harness connector.
 Do more than 8 volts exist between triple-pressure switch harness terminal No. (42) and body ground?

No
 Disconnect ECM (ECCS control module) harness connector.
 (Go to next page.)

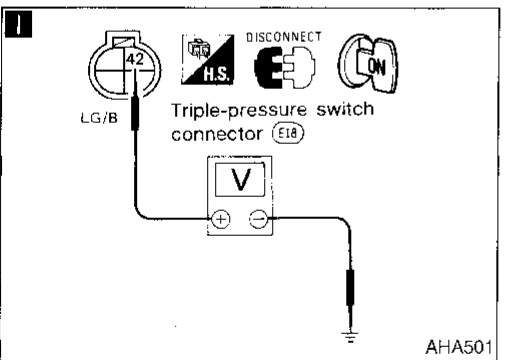

I
CHECK TRIPLE-PRESSURE SWITCH.
 Refer to HA-56.

NG
 Replace triple-pressure switch.

OK
 Disconnect thermo control amp. harness connector.

(Go to next page.)

Note:
 If the result is NG or No after checking circuit continuity, repair harness or connector.

Diagnostic Procedure 5 (Cont'd)

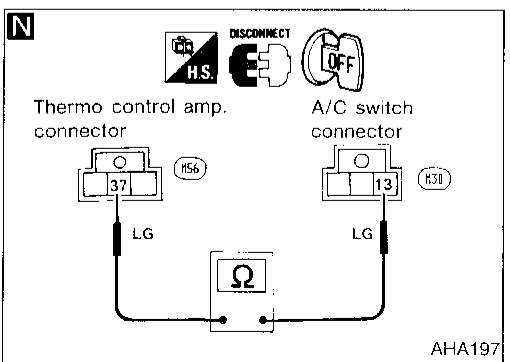
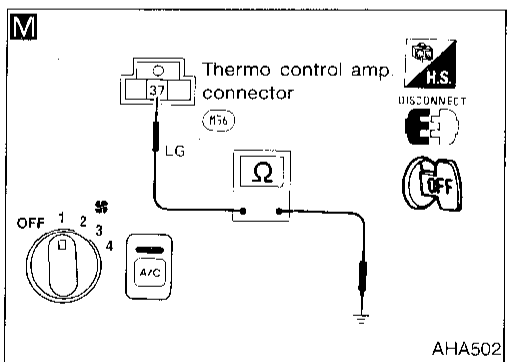
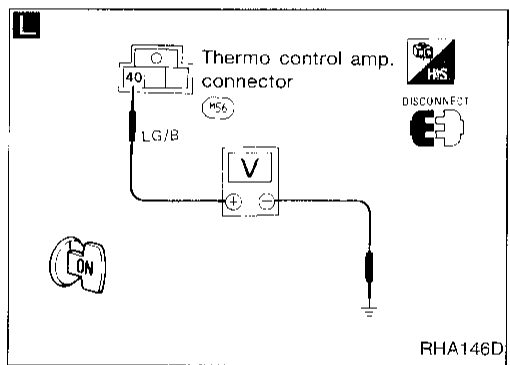
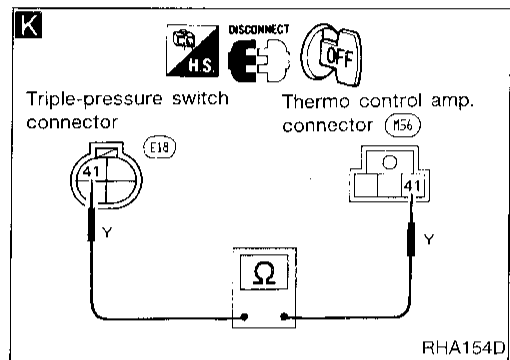
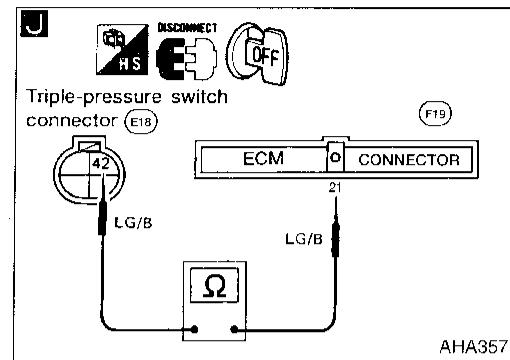

Note

J Check circuit continuity between ECM (ECCS control module) harness terminal No. (21) and triple-pressure switch harness terminal No. (42). (For terminal arrangement, refer to HA-37.)
Continuity should exist.
 If OK, check harness for short.

Note

K Check power supply for thermo control amp. Disconnect thermo control amp. harness connector. Do approx. 12 volts exist between thermo control amp. harness terminal No. (40) and body ground?

No Check 10A fuses at fuse block. Refer to EL section ("Wiring Diagram", "POWER SUPPLY ROUTING").

Yes

M Check body ground circuit for thermo control amp. Check harness continuity between thermo control amp. harness terminal No. (37) and body ground.
Continuity should exist.
 If OK, check harness for short.

OK Replace thermo control amp.

NG Disconnect A/C switch harness connector.

Note

N Check circuit continuity between thermo control amp. harness terminal No. (37) and A/C switch harness terminal No. (13).
Continuity should exist.
 If OK, check harness for short.

OK Check A/C switch. Refer to HA-55.

NG Replace A/C switch.

OK (Go to next page.)

Note:
 If the result is NG or No after checking circuit continuity, repair harness or connector.

Diagnostic Procedure 5 (Cont'd)

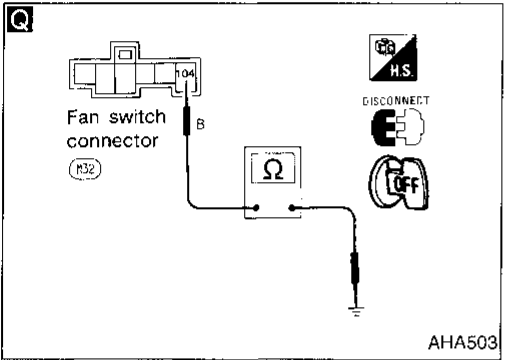
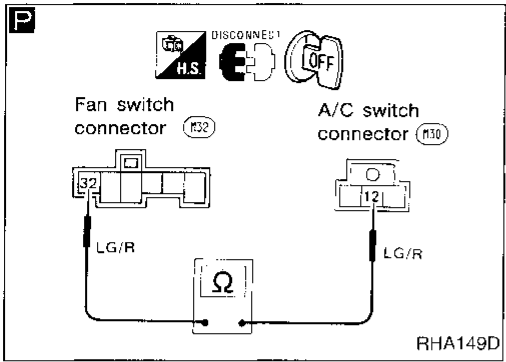

D

Disconnect fan switch harness connector.

P Note

CHECK CIRCUIT CONTINUITY BETWEEN A/C SWITCH HARNESS TERMINAL NO. (12) AND FAN SWITCH HARNESS TERMINAL NO. (32).
Continuity should exist.
 If OK, check harness for short.

OK

Q Note

CHECK BODY GROUND CIRCUIT FOR FAN SWITCH.
 Does continuity exist between fan switch harness terminal No. (104) and body ground?

Yes

CHECK FAN SWITCH.
 Refer to HA-55.

NG → Replace fan switch.

Note:
 If the result is NG or No after checking circuit continuity, repair harness or connector.

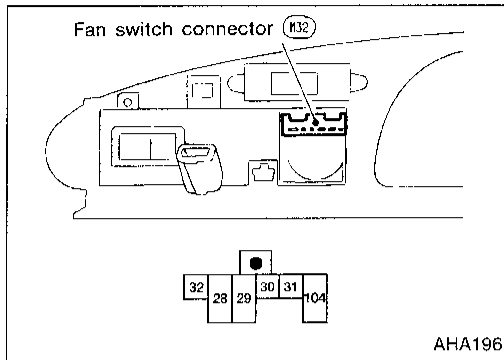

Electrical Components Inspection

FAN SWITCH

Check continuity between terminals at each position.

TERMINAL	POSITION				
	OFF	1	2	3	4
28					○
29				○	○
30			○	○	○
31		○	○	○	○
32		○	○	○	○
104		○	○	○	○

GI

MA

EM

LG

EC

FE

CL

MT

AT

FA

RA

BR

ST

RS

BT

HA

EL

IDX

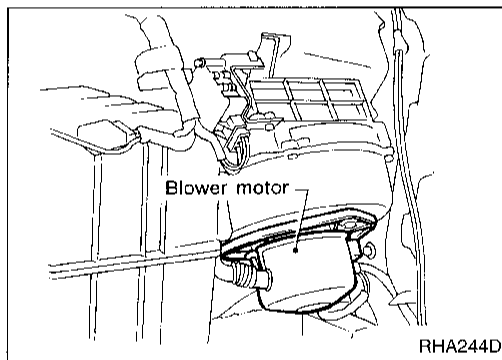

BLOWER MOTOR

Confirm smooth rotation of the blower motor.

- Check that there are no foreign particles inside the intake unit.

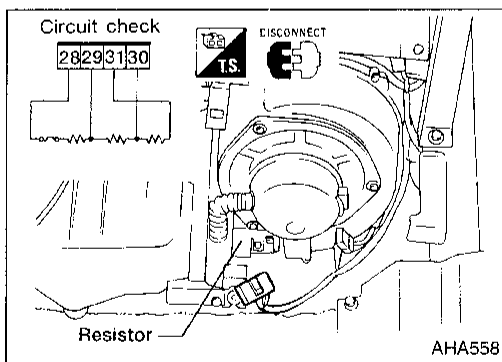

BLOWER RESISTOR

Check continuity between terminals.

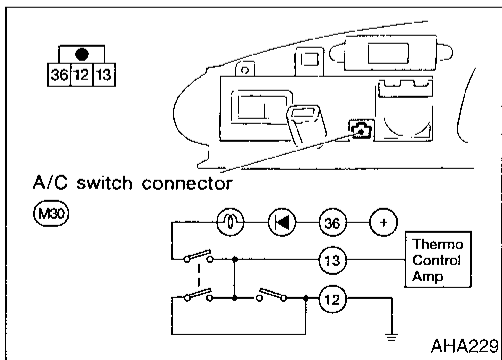

A/C SWITCH

Check continuity between terminals.

Electrical Components Inspection (Cont'd)

THERMO CONTROL AMP.

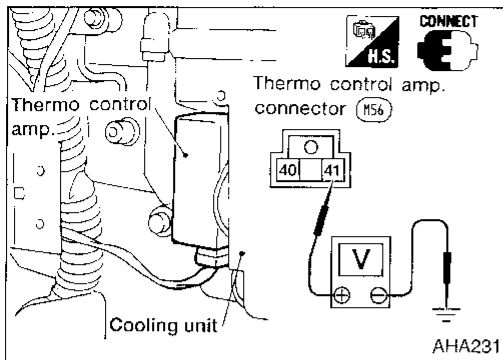

1. Run engine, and operate A/C system.
2. Connect the voltmeter from harness side.
3. Check thermo control amp. operation shown in the table.

Evaporator outlet air temperature °C (°F)	Thermo amp. operation	Tester
Decreasing to 2.5 - 3.5 (37 - 38)	Turn OFF	Approx. 12V
Increasing to 4.0 - 5.0 (39 - 41)	Turn ON	Approx. 0V

THERMAL PROTECTOR

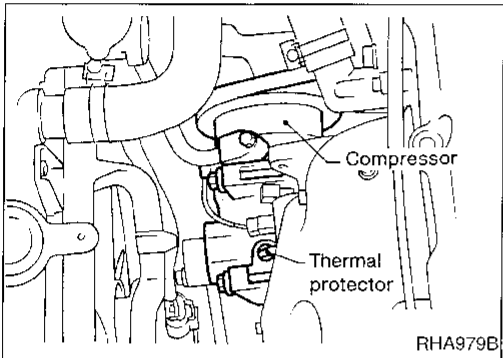

Temperature of compressor °C (°F)	Operation
Increasing to approx. 145 - 155 (293 - 311)	Turn OFF
Decreasing to approx. 130 - 140 (266 - 284)	Turn ON

If NG, replace thermal protector.

TRIPLE-PRESSURE SWITCH

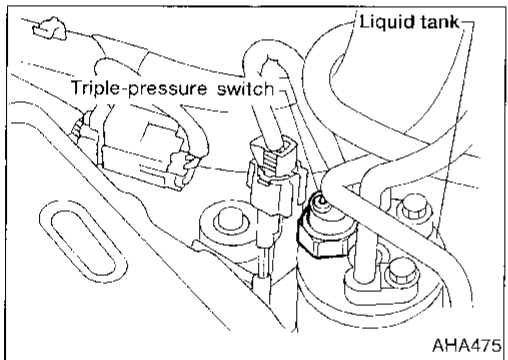

	ON kPa (kg/cm ² , psi)	OFF kPa (kg/cm ² , psi)
Low-pressure side	157 - 226 (1.6 - 2.3, 23 - 33)	152.0 - 201.0 (1.55 - 2.05, 22.0 - 29.2)
Medium-pressure side*	1,422 - 1,618 (14.5 - 16.5, 206 - 235)	1,128 - 1,422 (11.5 - 14.5, 164 - 206)
High-pressure side	1,667 - 2,059 (17 - 21, 242 - 299)	2,452 - 2,844 (25 - 29, 356 - 412)

* For cooling fan motor operation.

A/C RELAY

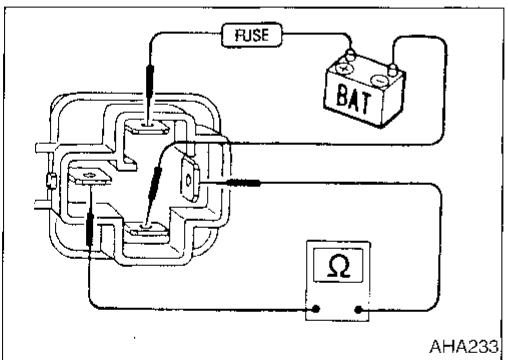



Check circuit continuity between terminals by supplying 12 volts to coil side terminals of A/C relay.

Control Linkage Adjustment

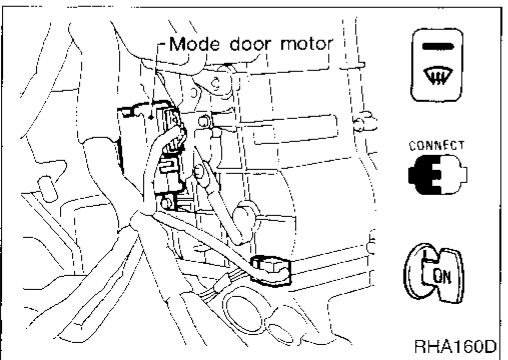
MODE DOOR

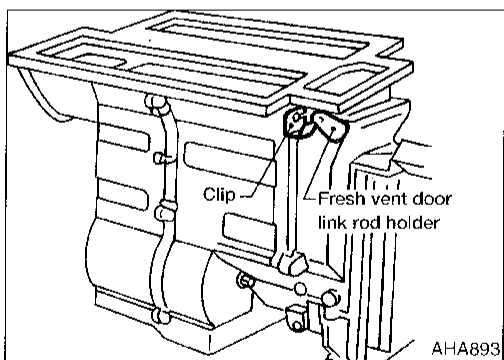
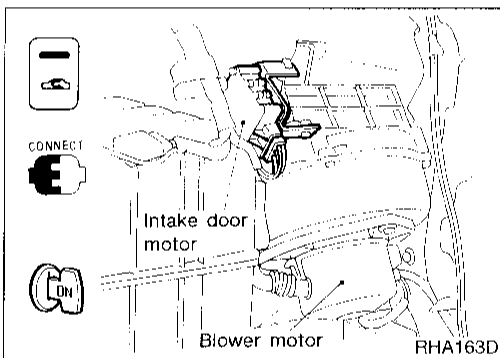
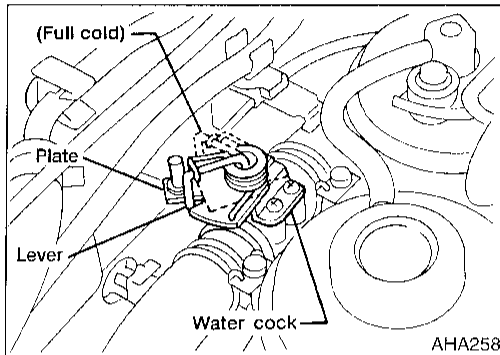
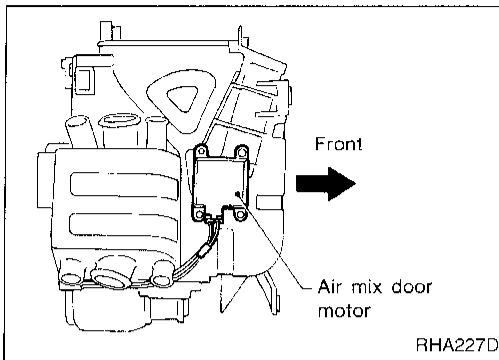

1. Move side link by hand and hold mode door in DEF mode.
2. Install mode door motor on heater unit and connect it to main harness.
3. Turn ignition switch ON.
4. Select FACE  mode.
5. Attach mode door motor rod to side link rod holder.
6. Select DEF  mode. Check that side link moves to the fully-open position.

Control Linkage Adjustment (Cont'd)**AIR MIX DOOR (Water cock)**

1. Move air mix link by hand and hold air mix door in full cold position.
2. Install air mix door motor on heater unit and connect sub-harness.
3. Turn ignition switch ON.
4. Slide temperature control lever to full cold.
5. Attach air mix door motor rod to air mix door link rod holder.
6. Check that air mix door operates properly when temperature control lever is slid to full hot and full cold.
7. Slide temperature control lever to full cold.
8. Attach water cock cable to air mix door linkage and secure with clip.
9. Rotate and hold water cock lever and plate in the full cold position (CLOCKWISE completely).
10. Attach water cock cable to plate and secure with clip (white mark on cable housing should be centered under the retaining clip).
11. Check that water cock operates properly when temperature lever is slid to full hot and full cold. (After several cycles, water cock lever should be midpoint of plate opening when temperature slider is full cold.)

INTAKE DOOR

1. Connect intake door motor harness connector before installing intake door motor.
2. Turn ignition switch ON.
3. Press REC  switch ON.
4. Install intake door motor on intake unit.
5. Install intake door lever.
6. Set intake door rod in REC position and fasten door rod to holder on intake door lever.
7. Check that intake door operates properly when REC switch is pressed ON and OFF.

FRESH VENT DOOR

1. The fresh vent door is held in the closed position by a clip. This prevents cold air from entering the passenger compartment when the bi-level mode is selected. No adjustment is necessary.

CI

MA

FM

IC

EC

FE

CI

MT

AT

FA

RA

BR

ST

RS

BT

HA

EL

DX

Introduction

The Automatic Temperature Control ATC system provides automatic regulation of the vehicles interior temperature. This system is based on the operator selected set temperature, regardless of the outside temperature changes. This is done by utilizing a microcomputer, also referred to as the automatic amplifier, which receives input signals from several sensors. The automatic amplifier uses these input signals (including the set temperature) to automatically control:

- Outlet air volume
- Air temperature
- Air distribution

Features

- **Air mix door control (Automatic temperature control)**

The air mix door is automatically controlled so that in-vehicle temperature is maintained at a predetermined value by: The temperature setting, ambient temperature, in-vehicle temperature, amount of sunload.

- **Fan speed control**

Blower speed is automatically controlled based on temperature setting, ambient temperature, in-vehicle temperature, amount of sunload and air mix door position.

With FAN switch set to AUTO, the blower motor starts to gradually increase air flow volume.

When engine coolant temperature is low, the blower motor operation is delayed to prevent cool air from flowing.

- **Intake door control**

The intake doors are automatically controlled by: The temperature setting, ambient temperature, in-vehicle temperature, amount of sunload and ON-OFF operation of the A/C switch.

- **Outlet door control**

The outlet door is automatically controlled by: The temperature setting, ambient temperature, in-vehicle temperature, and amount of sunload.

- **Self-diagnostic system**

The self-diagnostic system is built into the auto amplifier to quickly locate the cause of problems.

Control Operation

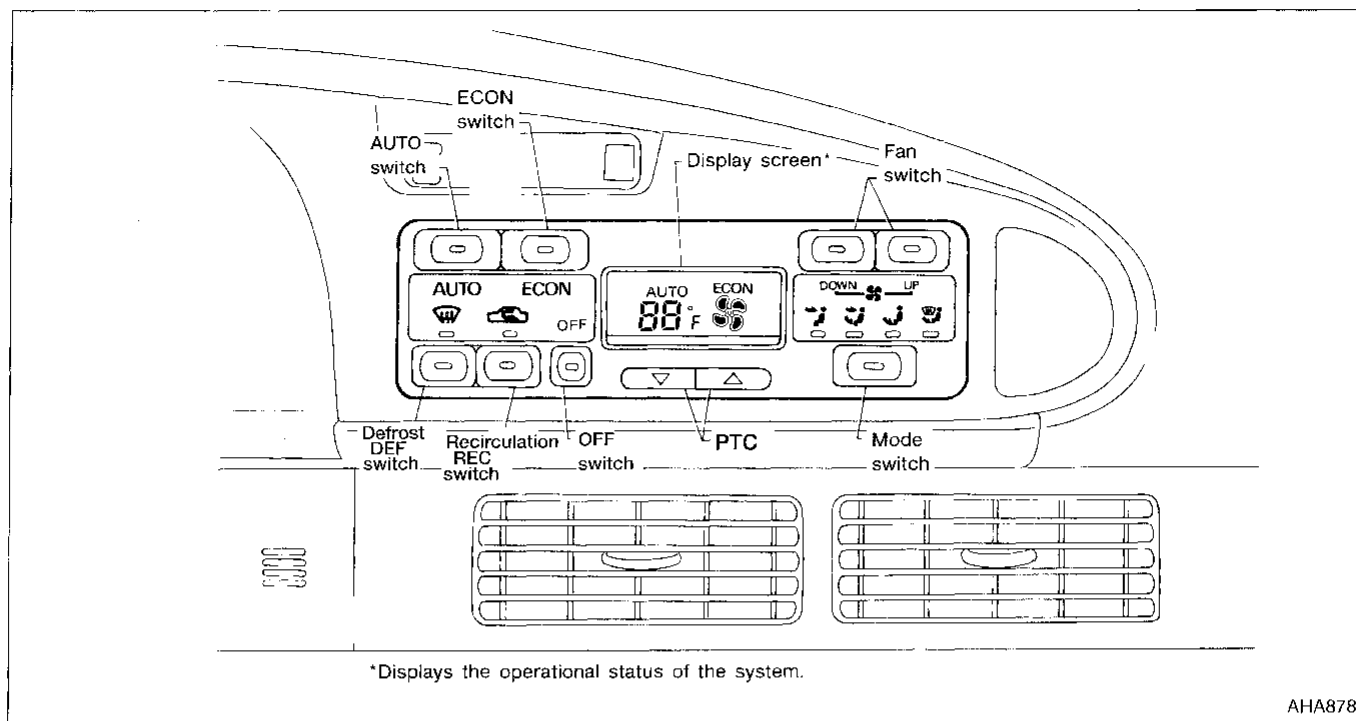
**AUTO SWITCH**

The following components are automatically controlled so that the in-vehicle temperature will reach and maintain the set temperature.

- Compressor
- Air intake door
- Air mix door
- Mode doors
- Blower speed

The air conditioner cooling function operates only when the engine is running.

ECON (ECONOMY) SWITCH

Fully automatic control with the compressor OFF. With the compressor off, the system will not remove heat (cool) or de-humidify. The system will maintain the in-vehicle temperature at the set temperature when the set temperature is above the ambient (outside) temperature.

PTC (Potentio Temperature Control)





Increases or decreases the set temperature.

OFF SWITCH

The compressor and blower are off, the air intake doors are set to the outside air position, and the mode doors are set to the FOOT (78% foot and 22% defrost) position. In the OFF position the ATC system uses the vehicle's flow through ventilation to try to maintain the interior temperature based on the temperature set when the system was last operating.

FAN SWITCH

Manual control of the blower speed. Four speeds are available for manual control (as shown on the display screen):

low , medium low , medium high , high 

Control Operation (Cont'd)**MODE SWITCH**

Manual control of the air discharge outlets. Four selections are available (as shown on the display screen):

FACE  , BI-LEVEL, B/L  , FOOT  , FOOT and DEFROST, F/D 

RECIRCULATION SWITCH

ON position: Interior air is recirculated inside the vehicle.

OFF position: Automatic control resumes.

Recirculation is canceled when AUTO, DEF  or ECON is selected, and resumes when another mode is chosen.

DEFROST SWITCH

Positions the mode doors to the defrost position. Also positions the air intake doors to the outside air position. The compressor operates at ambient temperature approx. 2°C (35°F) or above.

How to Perform Trouble Diagnoses for Quick and Accurate Repair

WORK FLOW

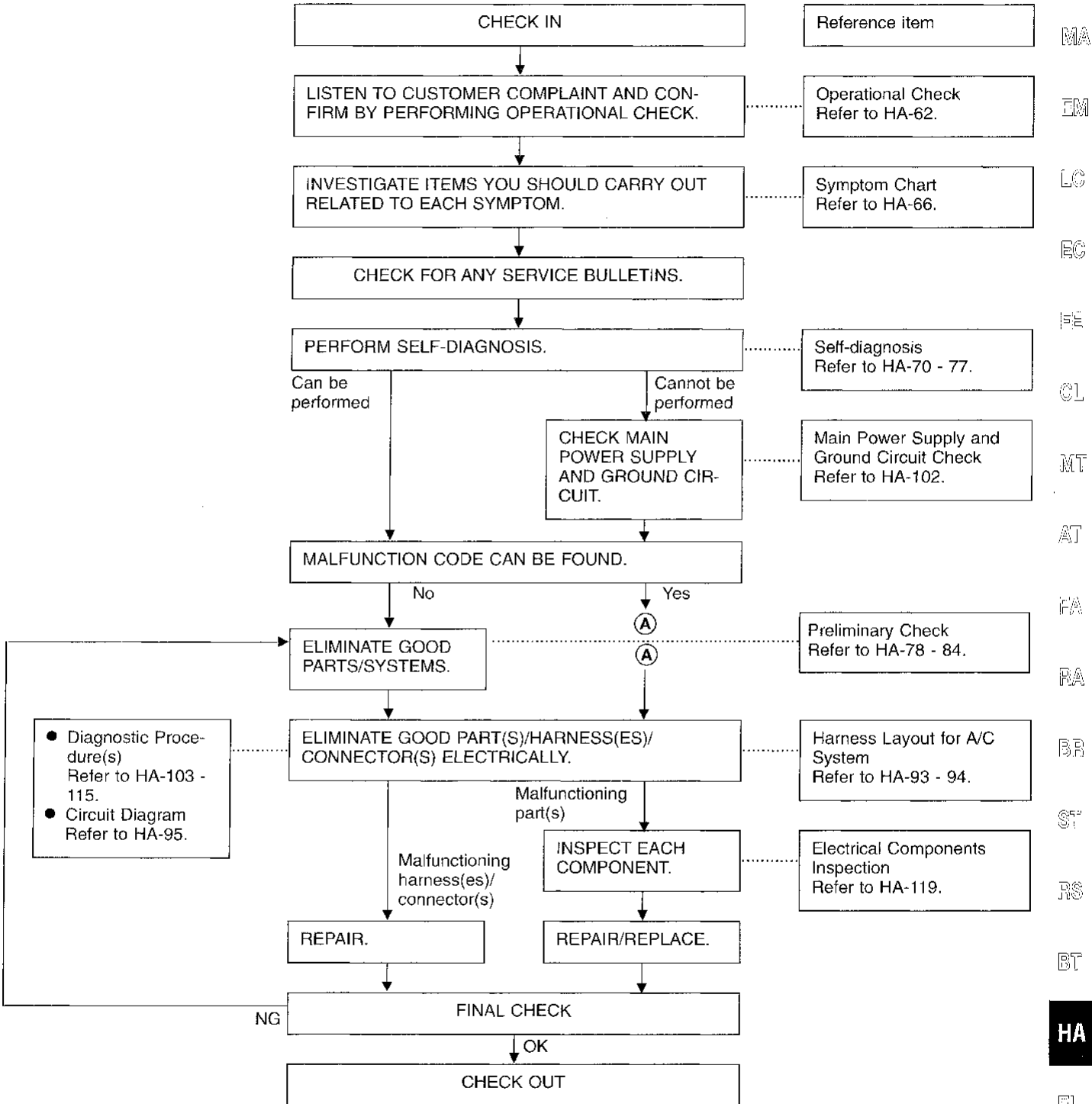

CL
 MA
 EM
 LC
 EC
 FE
 CL
 MT
 AT
 FA
 FA
 BR
 ST
 RS
 BT
HA
 EL
 IDX

Operational Check



The purpose of the operational check is to confirm that the system operates properly.

CONDITIONS:

- Engine running and at normal operating temperature.

PROCEDURE:

1. Check blower

- Press fan switch (up side) one time. Blower should operate on low speed. The fan symbol should have one blade lit .
- Press fan switch (up side) one more time, and continue checking blower speed and fan symbol until all speeds are checked.
- Leave blower on MAX speed .

2. Check discharge air

- Press mode switch four times and DEF button.

- Confirm that discharge air comes out according to the air distribution table at left.

Refer to "Discharge Air Flow", HA-13.



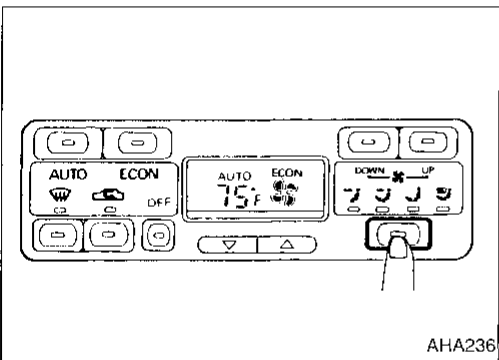
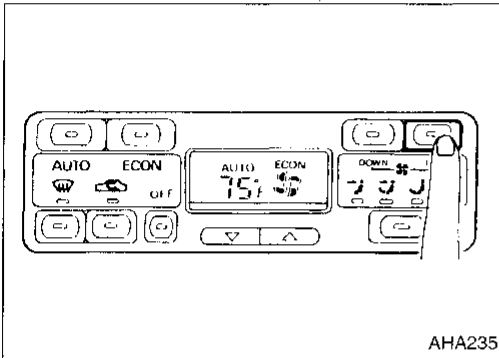

NOTE:

Confirm that the compressor clutch is engaged (visual inspection) and intake door position is at FRESH when the DEF  mode is selected.

Intake door position is checked in the next step.



Discharge air flow

Switch mode/ indicator	Air outlet/distribution		
	Face	Foot	Defrost
	100%	—	—
	60%	40%	—
	—	78%	22%
	—	55%	45%
	—	—	100%

AHA903

Operational Check (Cont'd)

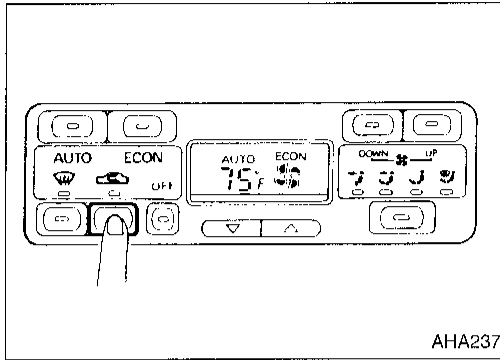

3. Check recirculation

- a. Press REC  switch.
Recirculation indicator should illuminate.
- b. Listen for intake door position change (you should hear blower sound change slightly).

GI

MA

EM

IC

EC

HE

CL

MT

AT

PA

RA

BR

ST

RS

BT

HA

EL

IDX

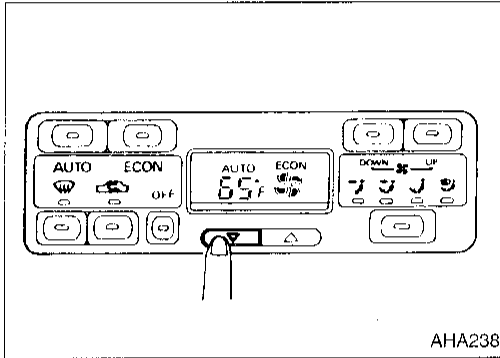

4. Check temperature decrease

- a. Press the temperature decrease button until 18°C (65°F) is displayed.
- b. Check for cold air at discharge air outlets.

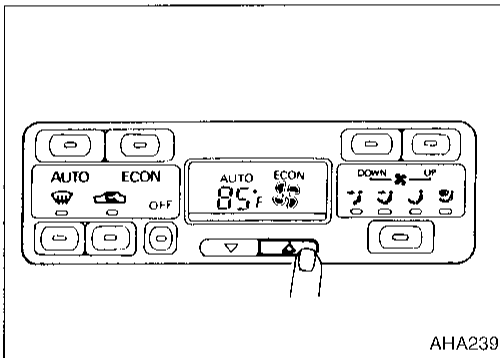

5. Check temperature increase

- a. Press the temperature increase button until 32°C (85°F) is displayed.
- b. Check for hot air at discharge air outlets.

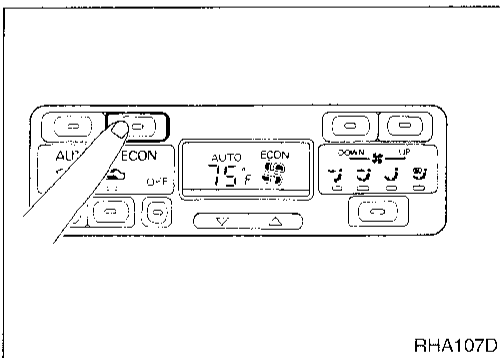

6. Check ECON (ECONOMY) mode

- a. Press ECON switch.
- b. Display should indicate ECON (no AUTO, no MANUAL).
Confirm that the compressor clutch is not engaged (visual inspection).
(Discharge air will depend on ambient, in-vehicle, and set temperatures).

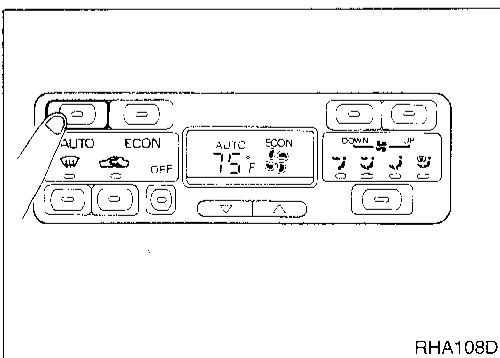

7. Check AUTO mode

- a. Press AUTO switch.
- b. Display should indicate AUTO (no ECON, no MANUAL).
Confirm that the compressor clutch engages (audio or visual inspection).
(Discharge air will depend on ambient, in-vehicle, and set temperatures).

Operational Check (Cont'd)**8. Check memory function**

- a. Press OFF switch.
- b. Turn the ignition OFF.
- c. Turn the ignition ON.
- d. Press the AUTO switch.
- e. Confirm that the set temperature remains at previous temperature.

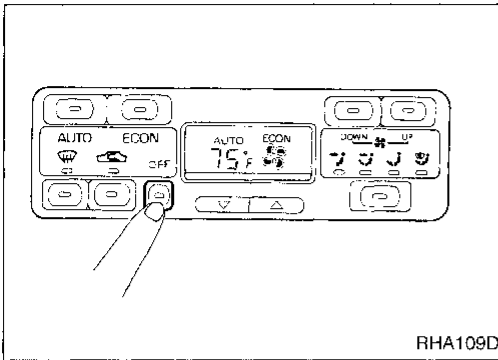

NOTES

GI

MA

FM

LC

EC

FE

CL

WT

AT

FA

RA

BR

ST

RS

BT

HA

EL

IDX

Symptom Chart

DIAGNOSTIC TABLE

PROCEDURE		Self-diagnosis					Preliminary Check								Diagnostic Procedure				
REFERENCE PAGE		HA-71, 73	HA-71, 73	HA-72, 74	HA-72, 75	HA-72, 75	HA-77	HA-78	HA-79	HA-80	HA-81	HA-82	HA-83	HA-84	HA-85	HA-103	HA-104	HA-105	HA-106
SYMPTOM		STEP 1	STEP 2	STEP 3	STEP 4	STEP 5	AUXILIARY MECHANISM	Preliminary Check 1	Preliminary Check 2	Preliminary Check 3	Preliminary Check 4	Preliminary Check 5	Preliminary Check 6	Preliminary Check 7	Preliminary Check 8	Diagnostic Procedure 1	Diagnostic Procedure 2	Diagnostic Procedure 3	Diagnostic Procedure 4
Air outlet does not change.		①	②	○	○	○		③								○	○	○	○
Intake door does not change.		①	②		○	○			③							○	○	○	○
Insufficient cooling.		○	○	○	○	○	○	○	○	①		○	○	○		○	○	○	○
Insufficient heating.		○	○	○	○	○	○	○	○		①	○		○		○	○	○	○
Blower motor operation is malfunctioning.		①	②		○	○						③				○	○	○	○
Magnet clutch does not engage.		①	②		○	○							③			○	○	○	○
Discharged air temperature does not change.		①	②		○	○								③		○	○	○	○
Noise.															①				
Result Self-diagnosis STEP 2	21 Ambient sensor circuit is open.	①	②			③										④			
	22 In-vehicle sensor circuit is open.	①	②			③											④		
	25 Sunload sensor circuit is open.	①	②															③	
	26 PBR circuit is open.	①	②																③

①, ②, ...: The number means checking order.
 ○: Checking order depends on malfunction in each flow chart.

Symptom Chart (Cont'd)

Diagnostic Procedure		Main Power Supply and Ground Circuit Check	Electrical Components Inspection															
HA-107	Diagnostic Procedure 5																	
HA-109	Diagnostic Procedure 6																	
HA-110	Diagnostic Procedure 7																	
HA-111	Diagnostic Procedure 8																	
HA-112	Diagnostic Procedure 9																	
HA-115	Diagnostic Procedure 10																	
HA-102	Auto amp.																	
HA-102	10A Fuse #26																	
HA-102	20A Fuses #7 and #8																	
HA-102	10A Fuse #6																	
HA-102	10A Fuse #10																	
HA-124	Ambient sensor																	
HA-123	In-vehicle sensor																	
HA-124	Sunload sensor																	
HA-127	PBR																	
HA-127	Air mix door motor																	
HA-129	Mode door motor																	
HA-130	Intake door motor																	
HA-121	Fresh vent door motor																	
HA-119	Blower motor																	
HA-119	Thermo control amp.																	
HA-119	Blower high relay																	
HA-119	A/C relay																	
HA-119	Triple-pressure switch																	
HA-133	Magnet clutch (Compressor)																	
	ECM (ECCS control module)																	
	Cooling fan motor-1																	
	Cooling fan motor-2																	
	Cooling fan relay-1																	
	Cooling fan relay-2																	
	Cooling fan relay-3																	
	Vehicle speed sensor																	
	Harness																	

CI

MA

EM

LC

EC

FF

CL

MT

AT

FA

RA

BR

ST

RS

BT

HA

EL

IDX

Symptom Chart (Cont'd)

PROCEDURE		Self-diagnosis					Preliminary Check								Diagnostic Procedure				
REFERENCE PAGE		HA-71, 73	HA-71, 73	HA-72, 74	HA-72, 75	HA-72, 75	HA-77	HA-78	HA-79	HA-80	HA-81	HA-82	HA-83	HA-84	HA-85	HA-103	HA-104	HA-105	HA-106
SYMPTOM		STEP 1	STEP 2	STEP 3	STEP 4	STEP 5	AUXILIARY MECHANISM	Preliminary Check 1	Preliminary Check 2	Preliminary Check 3	Preliminary Check 4	Preliminary Check 5	Preliminary Check 6	Preliminary Check 7	Preliminary Check 8	Diagnostic Procedure 1	Diagnostic Procedure 2	Diagnostic Procedure 3	Diagnostic Procedure 4
Result of Self-diagnosis STEP 2	ECON 21 Ambient sensor circuit is shorted.	①	②			③										④			
	ECON 22 In-vehicle sensor circuit is shorted.	①	②			③											④		
	ECON 25 Sunload sensor circuit is shorted.	①	②															③	
	ECON 26 PBR circuit is shorted.	①	②																③
Mode door motor does not operate normally.		①	②	③	④	○										○	○	○	○
Intake door motor does not operate normally.		①	②		③	○										○	○	○	○
Air mix door motor does not operate normally.		①	②		③	○										○	○	○	○
Fresh vent door does not operate normally.		①	②		③														
Blower motor operation is malfunctioning under Starting Fan Speed Control.		①	②		○	○						③				○	○	○	○
Magnet clutch does not operate after performing Preliminary Check 6.		①	②		○	○							③			○	○	○	○
Self-diagnosis cannot be performed.																			

①, ②, ...: The number means checking order.
 ○: Checking order depends on malfunction in each flow chart.

Symptom Chart (Cont'd)

Diagnostic Procedure		Main Power Supply and Ground Circuit Check	Electrical Components Inspection																																																																																																																																																																																																																																																																																																																																																																																																																																																																																								
	Diagnostic Procedure 5	HA-107													Diagnostic Procedure 6	HA-109													Diagnostic Procedure 7	HA-110													Diagnostic Procedure 8	HA-111													Diagnostic Procedure 9	HA-112													Diagnostic Procedure 10	HA-115													Diagnostic Procedure 11	HA-118													Auto amp.	HA-102													10A Fuse #26	HA-102													20A Fuses #7 and #8	HA-102													10A Fuse #6	HA-102													10A Fuse #10	HA-102													Ambient sensor	HA-124													In-vehicle sensor	HA-123													Sunload sensor	HA-124													PBR	HA-127													Air mix door motor	HA-127													Mode door motor	HA-129													Intake door motor	HA-130													Fresh vent door motor	HA-121													Blower motor	HA-119													Thermo control amp.	HA-119													Blower high relay	HA-119													A/C relay	HA-119													Triple-pressure switch	HA-119													Magnet clutch (Compressor)	HA-133													ECM (ECCS control module)														Cooling fan motor-1														Cooling fan motor-2														Cooling fan relay-1														Cooling fan relay-2														Cooling fan relay-3														Vehicle speed sensor														Harness	—											
	Diagnostic Procedure 6	HA-109													Diagnostic Procedure 7	HA-110													Diagnostic Procedure 8	HA-111													Diagnostic Procedure 9	HA-112													Diagnostic Procedure 10	HA-115													Diagnostic Procedure 11	HA-118													Auto amp.	HA-102													10A Fuse #26	HA-102													20A Fuses #7 and #8	HA-102													10A Fuse #6	HA-102													10A Fuse #10	HA-102													Ambient sensor	HA-124													In-vehicle sensor	HA-123													Sunload sensor	HA-124													PBR	HA-127													Air mix door motor	HA-127													Mode door motor	HA-129													Intake door motor	HA-130													Fresh vent door motor	HA-121													Blower motor	HA-119													Thermo control amp.	HA-119													Blower high relay	HA-119													A/C relay	HA-119													Triple-pressure switch	HA-119													Magnet clutch (Compressor)	HA-133													ECM (ECCS control module)														Cooling fan motor-1														Cooling fan motor-2														Cooling fan relay-1														Cooling fan relay-2														Cooling fan relay-3														Vehicle speed sensor														Harness	—																									
	Diagnostic Procedure 7	HA-110													Diagnostic Procedure 8	HA-111													Diagnostic Procedure 9	HA-112													Diagnostic Procedure 10	HA-115													Diagnostic Procedure 11	HA-118													Auto amp.	HA-102													10A Fuse #26	HA-102													20A Fuses #7 and #8	HA-102													10A Fuse #6	HA-102													10A Fuse #10	HA-102													Ambient sensor	HA-124													In-vehicle sensor	HA-123													Sunload sensor	HA-124													PBR	HA-127													Air mix door motor	HA-127													Mode door motor	HA-129													Intake door motor	HA-130													Fresh vent door motor	HA-121													Blower motor	HA-119													Thermo control amp.	HA-119													Blower high relay	HA-119													A/C relay	HA-119													Triple-pressure switch	HA-119													Magnet clutch (Compressor)	HA-133													ECM (ECCS control module)														Cooling fan motor-1														Cooling fan motor-2														Cooling fan relay-1														Cooling fan relay-2														Cooling fan relay-3														Vehicle speed sensor														Harness	—																																							
	Diagnostic Procedure 8	HA-111													Diagnostic Procedure 9	HA-112													Diagnostic Procedure 10	HA-115													Diagnostic Procedure 11	HA-118													Auto amp.	HA-102													10A Fuse #26	HA-102													20A Fuses #7 and #8	HA-102													10A Fuse #6	HA-102													10A Fuse #10	HA-102													Ambient sensor	HA-124													In-vehicle sensor	HA-123													Sunload sensor	HA-124													PBR	HA-127													Air mix door motor	HA-127													Mode door motor	HA-129													Intake door motor	HA-130													Fresh vent door motor	HA-121													Blower motor	HA-119													Thermo control amp.	HA-119													Blower high relay	HA-119													A/C relay	HA-119													Triple-pressure switch	HA-119													Magnet clutch (Compressor)	HA-133													ECM (ECCS control module)														Cooling fan motor-1														Cooling fan motor-2														Cooling fan relay-1														Cooling fan relay-2														Cooling fan relay-3														Vehicle speed sensor														Harness	—																																																					
	Diagnostic Procedure 9	HA-112													Diagnostic Procedure 10	HA-115													Diagnostic Procedure 11	HA-118													Auto amp.	HA-102													10A Fuse #26	HA-102													20A Fuses #7 and #8	HA-102													10A Fuse #6	HA-102													10A Fuse #10	HA-102													Ambient sensor	HA-124													In-vehicle sensor	HA-123													Sunload sensor	HA-124													PBR	HA-127													Air mix door motor	HA-127													Mode door motor	HA-129													Intake door motor	HA-130													Fresh vent door motor	HA-121													Blower motor	HA-119													Thermo control amp.	HA-119													Blower high relay	HA-119													A/C relay	HA-119													Triple-pressure switch	HA-119													Magnet clutch (Compressor)	HA-133													ECM (ECCS control module)														Cooling fan motor-1														Cooling fan motor-2														Cooling fan relay-1														Cooling fan relay-2														Cooling fan relay-3														Vehicle speed sensor														Harness	—																																																																			
	Diagnostic Procedure 10	HA-115													Diagnostic Procedure 11	HA-118													Auto amp.	HA-102													10A Fuse #26	HA-102													20A Fuses #7 and #8	HA-102													10A Fuse #6	HA-102													10A Fuse #10	HA-102													Ambient sensor	HA-124													In-vehicle sensor	HA-123													Sunload sensor	HA-124													PBR	HA-127													Air mix door motor	HA-127													Mode door motor	HA-129													Intake door motor	HA-130													Fresh vent door motor	HA-121													Blower motor	HA-119													Thermo control amp.	HA-119													Blower high relay	HA-119													A/C relay	HA-119													Triple-pressure switch	HA-119													Magnet clutch (Compressor)	HA-133													ECM (ECCS control module)														Cooling fan motor-1														Cooling fan motor-2														Cooling fan relay-1														Cooling fan relay-2														Cooling fan relay-3														Vehicle speed sensor														Harness	—																																																																																	
	Diagnostic Procedure 11	HA-118													Auto amp.	HA-102													10A Fuse #26	HA-102													20A Fuses #7 and #8	HA-102													10A Fuse #6	HA-102													10A Fuse #10	HA-102													Ambient sensor	HA-124													In-vehicle sensor	HA-123													Sunload sensor	HA-124													PBR	HA-127													Air mix door motor	HA-127													Mode door motor	HA-129													Intake door motor	HA-130													Fresh vent door motor	HA-121													Blower motor	HA-119													Thermo control amp.	HA-119													Blower high relay	HA-119													A/C relay	HA-119													Triple-pressure switch	HA-119													Magnet clutch (Compressor)	HA-133													ECM (ECCS control module)														Cooling fan motor-1														Cooling fan motor-2														Cooling fan relay-1														Cooling fan relay-2														Cooling fan relay-3														Vehicle speed sensor														Harness	—																																																																																															
	Auto amp.	HA-102													10A Fuse #26	HA-102													20A Fuses #7 and #8	HA-102													10A Fuse #6	HA-102													10A Fuse #10	HA-102													Ambient sensor	HA-124													In-vehicle sensor	HA-123													Sunload sensor	HA-124													PBR	HA-127													Air mix door motor	HA-127													Mode door motor	HA-129													Intake door motor	HA-130													Fresh vent door motor	HA-121													Blower motor	HA-119													Thermo control amp.	HA-119													Blower high relay	HA-119													A/C relay	HA-119													Triple-pressure switch	HA-119													Magnet clutch (Compressor)	HA-133													ECM (ECCS control module)														Cooling fan motor-1														Cooling fan motor-2														Cooling fan relay-1														Cooling fan relay-2														Cooling fan relay-3														Vehicle speed sensor														Harness	—																																																																																																													
	10A Fuse #26	HA-102													20A Fuses #7 and #8	HA-102													10A Fuse #6	HA-102													10A Fuse #10	HA-102													Ambient sensor	HA-124													In-vehicle sensor	HA-123													Sunload sensor	HA-124													PBR	HA-127													Air mix door motor	HA-127													Mode door motor	HA-129													Intake door motor	HA-130													Fresh vent door motor	HA-121													Blower motor	HA-119													Thermo control amp.	HA-119													Blower high relay	HA-119													A/C relay	HA-119													Triple-pressure switch	HA-119													Magnet clutch (Compressor)	HA-133													ECM (ECCS control module)														Cooling fan motor-1														Cooling fan motor-2														Cooling fan relay-1														Cooling fan relay-2														Cooling fan relay-3														Vehicle speed sensor														Harness	—																																																																																																																											
	20A Fuses #7 and #8	HA-102													10A Fuse #6	HA-102													10A Fuse #10	HA-102													Ambient sensor	HA-124													In-vehicle sensor	HA-123													Sunload sensor	HA-124													PBR	HA-127													Air mix door motor	HA-127													Mode door motor	HA-129													Intake door motor	HA-130													Fresh vent door motor	HA-121													Blower motor	HA-119													Thermo control amp.	HA-119													Blower high relay	HA-119													A/C relay	HA-119													Triple-pressure switch	HA-119													Magnet clutch (Compressor)	HA-133													ECM (ECCS control module)														Cooling fan motor-1														Cooling fan motor-2														Cooling fan relay-1														Cooling fan relay-2														Cooling fan relay-3														Vehicle speed sensor														Harness	—																																																																																																																																									
	10A Fuse #6	HA-102													10A Fuse #10	HA-102													Ambient sensor	HA-124													In-vehicle sensor	HA-123													Sunload sensor	HA-124													PBR	HA-127													Air mix door motor	HA-127													Mode door motor	HA-129													Intake door motor	HA-130													Fresh vent door motor	HA-121													Blower motor	HA-119													Thermo control amp.	HA-119													Blower high relay	HA-119													A/C relay	HA-119													Triple-pressure switch	HA-119													Magnet clutch (Compressor)	HA-133													ECM (ECCS control module)														Cooling fan motor-1														Cooling fan motor-2														Cooling fan relay-1														Cooling fan relay-2														Cooling fan relay-3														Vehicle speed sensor														Harness	—																																																																																																																																																							
	10A Fuse #10	HA-102													Ambient sensor	HA-124													In-vehicle sensor	HA-123													Sunload sensor	HA-124													PBR	HA-127													Air mix door motor	HA-127													Mode door motor	HA-129													Intake door motor	HA-130													Fresh vent door motor	HA-121													Blower motor	HA-119													Thermo control amp.	HA-119													Blower high relay	HA-119													A/C relay	HA-119													Triple-pressure switch	HA-119													Magnet clutch (Compressor)	HA-133													ECM (ECCS control module)														Cooling fan motor-1														Cooling fan motor-2														Cooling fan relay-1														Cooling fan relay-2														Cooling fan relay-3														Vehicle speed sensor														Harness	—																																																																																																																																																																					
	Ambient sensor	HA-124													In-vehicle sensor	HA-123													Sunload sensor	HA-124													PBR	HA-127													Air mix door motor	HA-127													Mode door motor	HA-129													Intake door motor	HA-130													Fresh vent door motor	HA-121													Blower motor	HA-119													Thermo control amp.	HA-119													Blower high relay	HA-119													A/C relay	HA-119													Triple-pressure switch	HA-119													Magnet clutch (Compressor)	HA-133													ECM (ECCS control module)														Cooling fan motor-1														Cooling fan motor-2														Cooling fan relay-1														Cooling fan relay-2														Cooling fan relay-3														Vehicle speed sensor														Harness	—																																																																																																																																																																																			
	In-vehicle sensor	HA-123													Sunload sensor	HA-124													PBR	HA-127													Air mix door motor	HA-127													Mode door motor	HA-129													Intake door motor	HA-130													Fresh vent door motor	HA-121													Blower motor	HA-119													Thermo control amp.	HA-119													Blower high relay	HA-119													A/C relay	HA-119													Triple-pressure switch	HA-119													Magnet clutch (Compressor)	HA-133													ECM (ECCS control module)														Cooling fan motor-1														Cooling fan motor-2														Cooling fan relay-1														Cooling fan relay-2														Cooling fan relay-3														Vehicle speed sensor														Harness	—																																																																																																																																																																																																	
	Sunload sensor	HA-124													PBR	HA-127													Air mix door motor	HA-127													Mode door motor	HA-129													Intake door motor	HA-130													Fresh vent door motor	HA-121													Blower motor	HA-119													Thermo control amp.	HA-119													Blower high relay	HA-119													A/C relay	HA-119													Triple-pressure switch	HA-119													Magnet clutch (Compressor)	HA-133													ECM (ECCS control module)														Cooling fan motor-1														Cooling fan motor-2														Cooling fan relay-1														Cooling fan relay-2														Cooling fan relay-3														Vehicle speed sensor														Harness	—																																																																																																																																																																																																															
	PBR	HA-127													Air mix door motor	HA-127													Mode door motor	HA-129													Intake door motor	HA-130													Fresh vent door motor	HA-121													Blower motor	HA-119													Thermo control amp.	HA-119													Blower high relay	HA-119													A/C relay	HA-119													Triple-pressure switch	HA-119													Magnet clutch (Compressor)	HA-133													ECM (ECCS control module)														Cooling fan motor-1														Cooling fan motor-2														Cooling fan relay-1														Cooling fan relay-2														Cooling fan relay-3														Vehicle speed sensor														Harness	—																																																																																																																																																																																																																													
	Air mix door motor	HA-127													Mode door motor	HA-129													Intake door motor	HA-130													Fresh vent door motor	HA-121													Blower motor	HA-119													Thermo control amp.	HA-119													Blower high relay	HA-119													A/C relay	HA-119													Triple-pressure switch	HA-119													Magnet clutch (Compressor)	HA-133													ECM (ECCS control module)														Cooling fan motor-1														Cooling fan motor-2														Cooling fan relay-1														Cooling fan relay-2														Cooling fan relay-3														Vehicle speed sensor														Harness	—																																																																																																																																																																																																																																											
	Mode door motor	HA-129													Intake door motor	HA-130													Fresh vent door motor	HA-121													Blower motor	HA-119													Thermo control amp.	HA-119													Blower high relay	HA-119													A/C relay	HA-119													Triple-pressure switch	HA-119													Magnet clutch (Compressor)	HA-133													ECM (ECCS control module)														Cooling fan motor-1														Cooling fan motor-2														Cooling fan relay-1														Cooling fan relay-2														Cooling fan relay-3														Vehicle speed sensor														Harness	—																																																																																																																																																																																																																																																									
	Intake door motor	HA-130													Fresh vent door motor	HA-121													Blower motor	HA-119													Thermo control amp.	HA-119													Blower high relay	HA-119													A/C relay	HA-119													Triple-pressure switch	HA-119													Magnet clutch (Compressor)	HA-133													ECM (ECCS control module)														Cooling fan motor-1														Cooling fan motor-2														Cooling fan relay-1														Cooling fan relay-2														Cooling fan relay-3														Vehicle speed sensor														Harness	—																																																																																																																																																																																																																																																																							
	Fresh vent door motor	HA-121													Blower motor	HA-119													Thermo control amp.	HA-119													Blower high relay	HA-119													A/C relay	HA-119													Triple-pressure switch	HA-119													Magnet clutch (Compressor)	HA-133													ECM (ECCS control module)														Cooling fan motor-1														Cooling fan motor-2														Cooling fan relay-1														Cooling fan relay-2														Cooling fan relay-3														Vehicle speed sensor														Harness	—																																																																																																																																																																																																																																																																																					
	Blower motor	HA-119													Thermo control amp.	HA-119													Blower high relay	HA-119													A/C relay	HA-119													Triple-pressure switch	HA-119													Magnet clutch (Compressor)	HA-133													ECM (ECCS control module)														Cooling fan motor-1														Cooling fan motor-2														Cooling fan relay-1														Cooling fan relay-2														Cooling fan relay-3														Vehicle speed sensor														Harness	—																																																																																																																																																																																																																																																																																																			
	Thermo control amp.	HA-119													Blower high relay	HA-119													A/C relay	HA-119													Triple-pressure switch	HA-119													Magnet clutch (Compressor)	HA-133													ECM (ECCS control module)														Cooling fan motor-1														Cooling fan motor-2														Cooling fan relay-1														Cooling fan relay-2														Cooling fan relay-3														Vehicle speed sensor														Harness	—																																																																																																																																																																																																																																																																																																																	
	Blower high relay	HA-119													A/C relay	HA-119													Triple-pressure switch	HA-119													Magnet clutch (Compressor)	HA-133													ECM (ECCS control module)														Cooling fan motor-1														Cooling fan motor-2														Cooling fan relay-1														Cooling fan relay-2														Cooling fan relay-3														Vehicle speed sensor														Harness	—																																																																																																																																																																																																																																																																																																																															
	A/C relay	HA-119													Triple-pressure switch	HA-119													Magnet clutch (Compressor)	HA-133													ECM (ECCS control module)														Cooling fan motor-1														Cooling fan motor-2														Cooling fan relay-1														Cooling fan relay-2														Cooling fan relay-3														Vehicle speed sensor														Harness	—																																																																																																																																																																																																																																																																																																																																													
	Triple-pressure switch	HA-119													Magnet clutch (Compressor)	HA-133													ECM (ECCS control module)														Cooling fan motor-1														Cooling fan motor-2														Cooling fan relay-1														Cooling fan relay-2														Cooling fan relay-3														Vehicle speed sensor														Harness	—																																																																																																																																																																																																																																																																																																																																																											
	Magnet clutch (Compressor)	HA-133													ECM (ECCS control module)														Cooling fan motor-1														Cooling fan motor-2														Cooling fan relay-1														Cooling fan relay-2														Cooling fan relay-3														Vehicle speed sensor														Harness	—																																																																																																																																																																																																																																																																																																																																																																									
	ECM (ECCS control module)														Cooling fan motor-1														Cooling fan motor-2														Cooling fan relay-1														Cooling fan relay-2														Cooling fan relay-3														Vehicle speed sensor														Harness	—																																																																																																																																																																																																																																																																																																																																																																																							
	Cooling fan motor-1														Cooling fan motor-2														Cooling fan relay-1														Cooling fan relay-2														Cooling fan relay-3														Vehicle speed sensor														Harness	—																																																																																																																																																																																																																																																																																																																																																																																																					
	Cooling fan motor-2														Cooling fan relay-1														Cooling fan relay-2														Cooling fan relay-3														Vehicle speed sensor														Harness	—																																																																																																																																																																																																																																																																																																																																																																																																																			
	Cooling fan relay-1														Cooling fan relay-2														Cooling fan relay-3														Vehicle speed sensor														Harness	—																																																																																																																																																																																																																																																																																																																																																																																																																																	
	Cooling fan relay-2														Cooling fan relay-3														Vehicle speed sensor														Harness	—																																																																																																																																																																																																																																																																																																																																																																																																																																															
	Cooling fan relay-3														Vehicle speed sensor														Harness	—																																																																																																																																																																																																																																																																																																																																																																																																																																																													
	Vehicle speed sensor														Harness	—																																																																																																																																																																																																																																																																																																																																																																																																																																																																											
	Harness	—																																																																																																																																																																																																																																																																																																																																																																																																																																																																																									

GI
WA
EM
LC
GC
FE
CL
WI
AI
FA
BA
BR
ST

RS
BT
HA
EL
DX

Self-diagnosis

The self-diagnostic system diagnoses sensors, door motors, blower motor, etc. by system line. Refer to applicable sections (items) for details. Shifting from normal control to the self-diagnostic system is accomplished by starting the engine (turning the ignition switch from OFF to ON) and pressing **OFF** switch for at least 5 seconds. The **OFF** switch must be pressed within 5 seconds after starting the engine (ignition switch is turned ON). This system will be canceled by either pressing **AUTO** AUTO switch or turning the ignition switch OFF. Shifting from one step to another is accomplished by means of pushing **▲** HOT or **▼** COLD switch, as required. Additionally shifting from STEP 5 to AUXILIARY MECHANISM is accomplished by means of pushing **UP** fan UP switch.

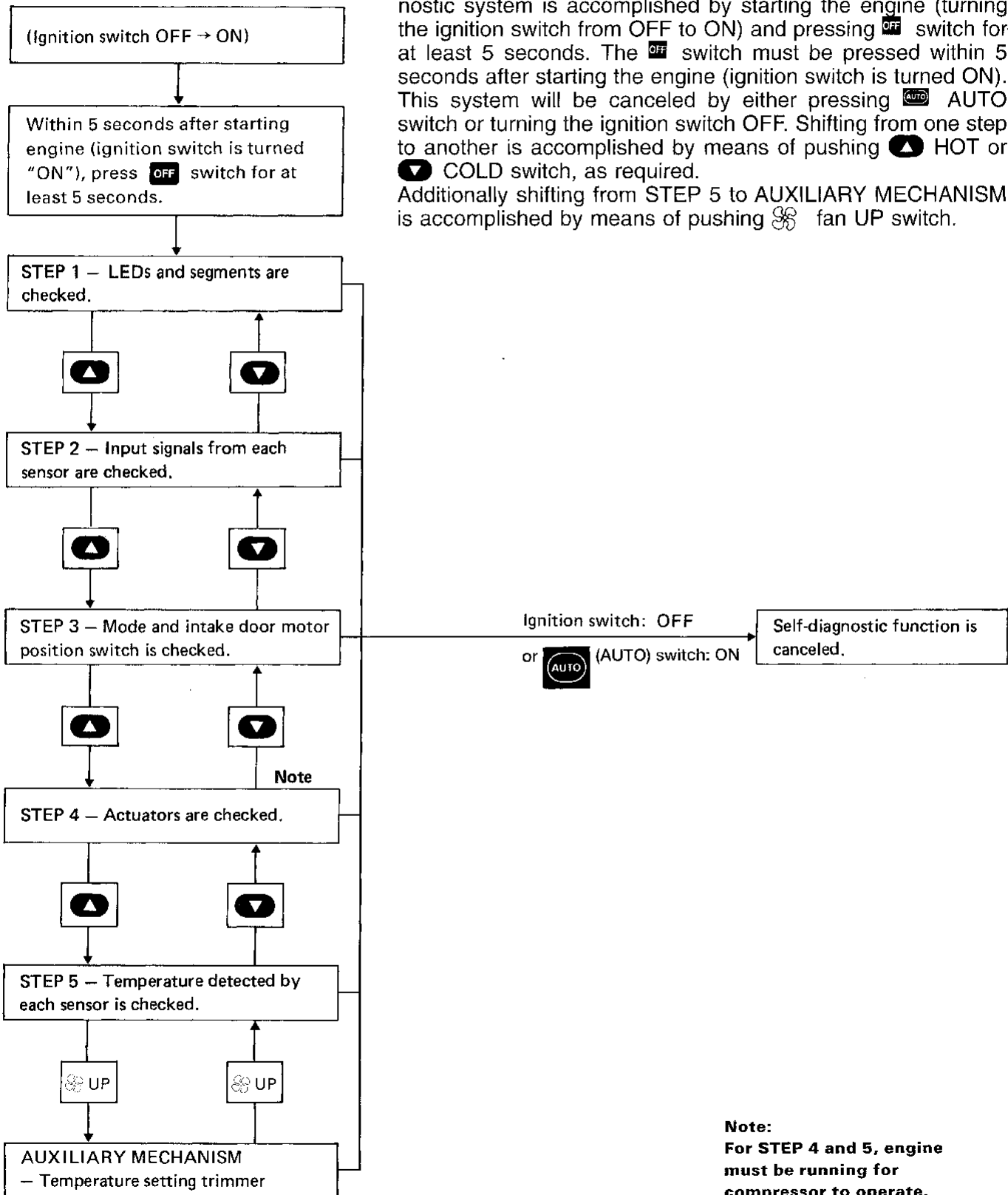

Note:
For STEP 4 and 5, engine must be running for compressor to operate.

AHA369

Self-diagnosis (Cont'd)

CHECKING PROCEDURE

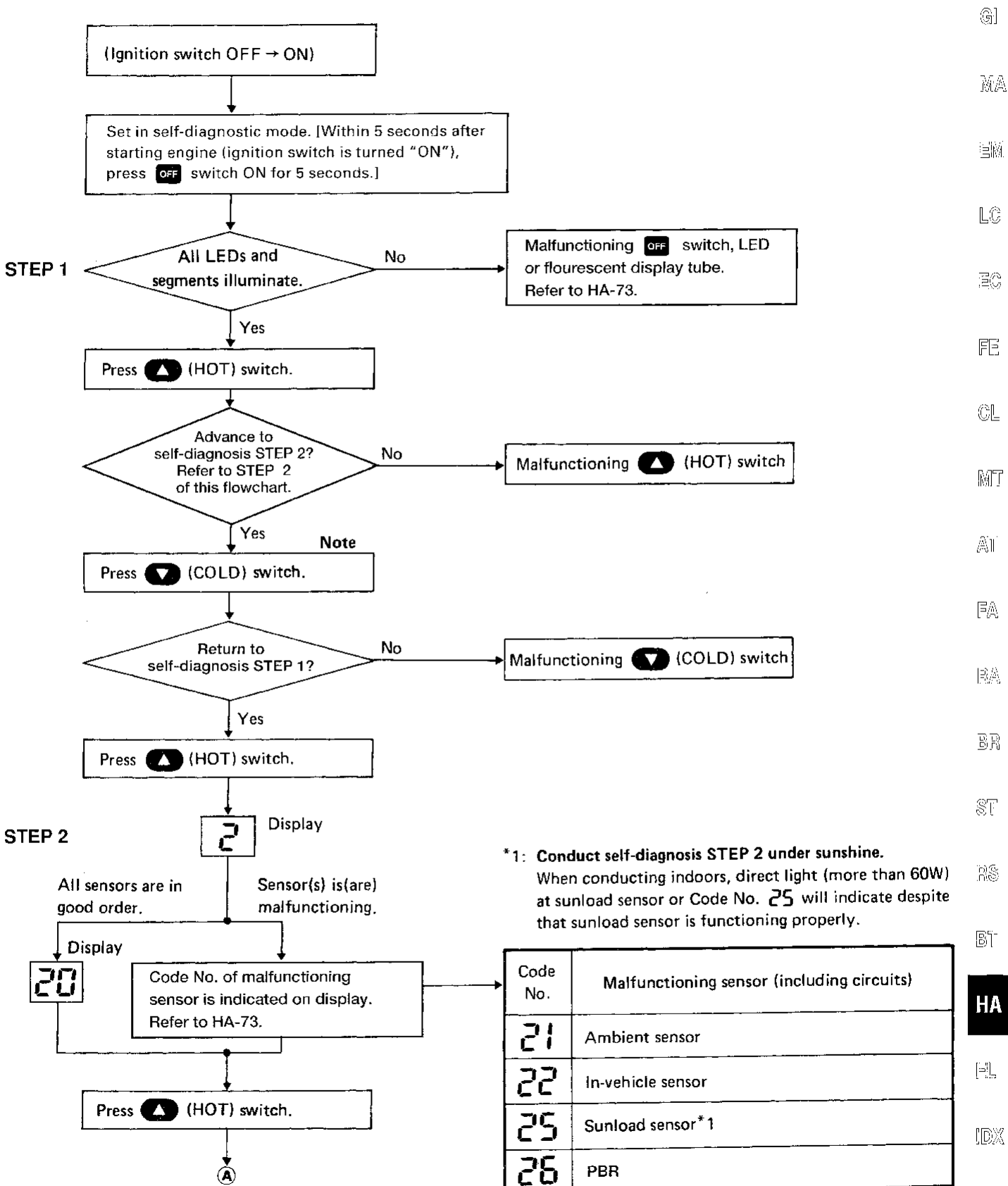

*1: Conduct self-diagnosis STEP 2 under sunshine. When conducting indoors, direct light (more than 60W) at sunload sensor or Code No. 25 will indicate despite that sunload sensor is functioning properly.

Code No.	Malfunctioning sensor (including circuits)
21	Ambient sensor
22	In-vehicle sensor
25	Sunload sensor*1
26	PBR

Note:
At any time, you can return to a previous step in the self-diagnosis by pressing the (COLD) switch.

Self-diagnosis (Cont'd)

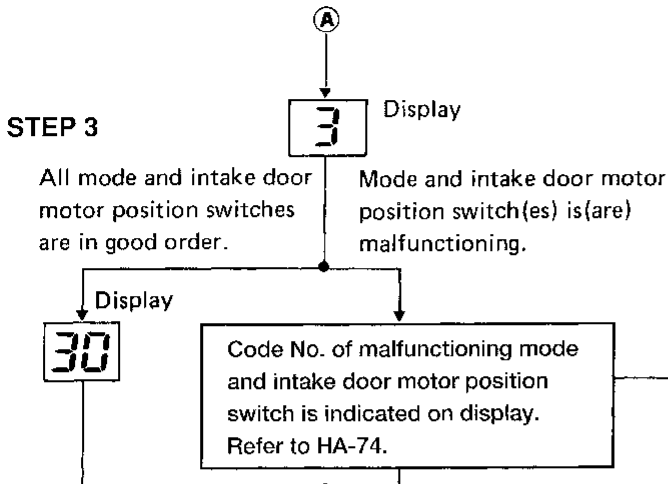

Code No.	Malfunctioning part or circuit	
	Position switch	
31	FACE	Mode door motor
32	B/L	
34	FOOT	
35	F/D	
36	DEF	
37	REC	
38	20% FRE	
39	FRE	

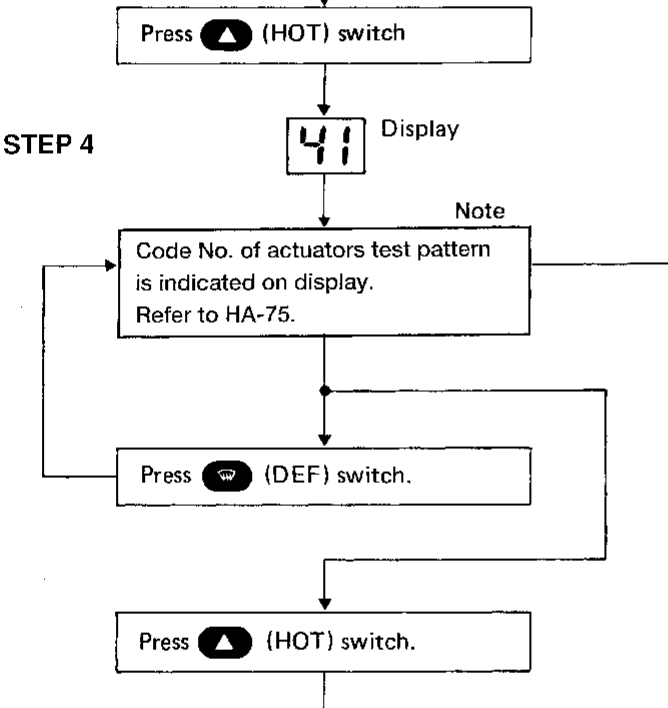

Code No.	Actuators test pattern					
	Mode door	Intake door	Air mix door	Fresh vent door	Blower motor	Compressor
41	FACE	REC	Full Cold	Open	4 - 5V	ON
42	B/L	REC	Full Cold	Open	9 - 11V	ON
43	B/L	20% FRE	Full Hot	Close	7 - 9V	ON
44	FOOT	FRE	Full Hot	Close	7 - 9V	OFF
45	F/D	FRE	Full Hot	Close	7 - 9V	OFF
46	DEF	FRE	Full Hot	Close	10 - 12V	ON

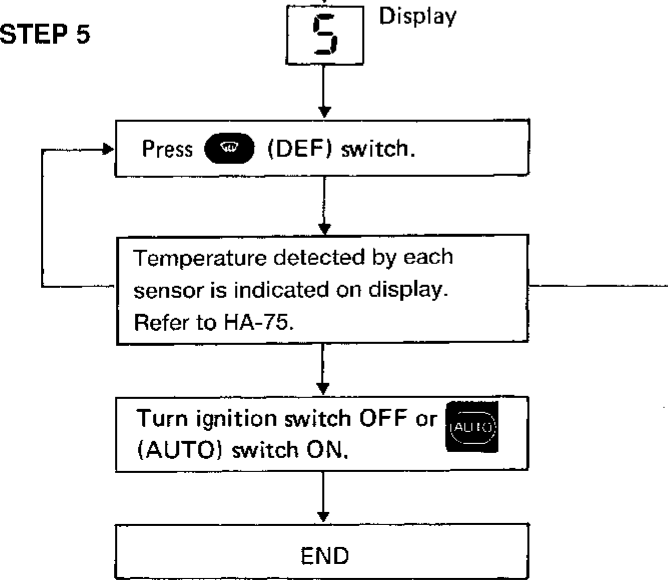

Note:
For STEP 4 and 5, engine must be running for compressor to operate.

Self-diagnosis (Cont'd)

STEP 1: Checks LEDs and segments

When switch's LED and segments are in good order in STEP 1 mode, the corresponding LED and fluorescent display tube will illuminate.

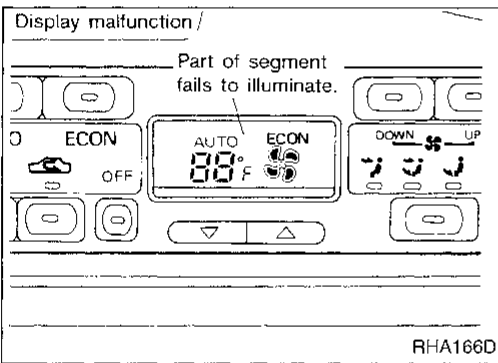
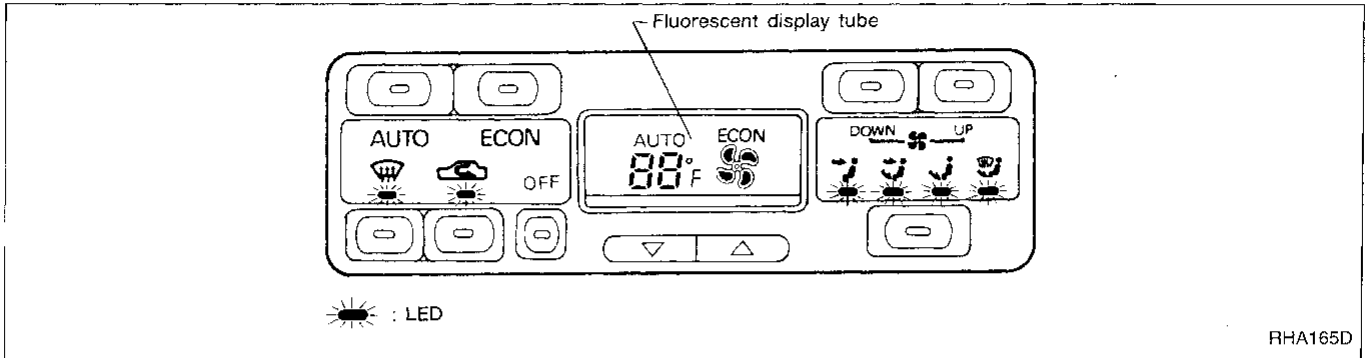

If LEDs or segments malfunction, LED does not come on or display shows incomplete segment.

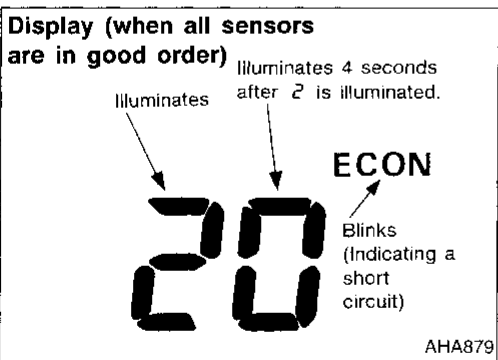

STEP 2: Checks each sensor circuit for open or short circuit

Display shows 2 in STEP 2 mode. When all sensors are in good order, display shows 20.

It takes approximately 4 seconds to check all sensors. If a circuit is shorted, display shows ECON mark blinks on display.

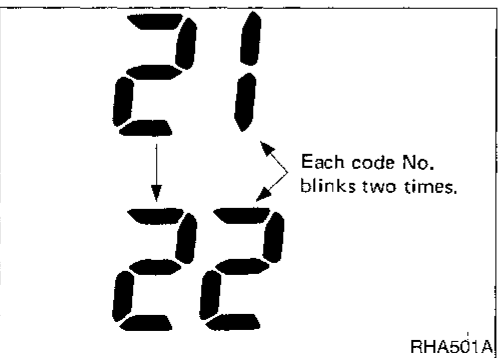

If two or more sensors malfunction, corresponding code Nos. respectively blink two times.

CI
WA
EM
LC
EC
FE
CL
MT
AT
FA
RA
BR
ST
RS
BT
HA
EL
IDX

Self-diagnosis (Cont'd)

Sensors and abnormalities

If a circuit is opened or shorted, display shows its code No. when input corresponds with any of following conditions.

Code No.	Sensor	Open circuit	Short circuit
21	Ambient sensor	Less than -50°C (-58°F)	Greater than 75°C (167°F)
22	In-vehicle sensor	Less than -50°C (-58°F)	Greater than 75°C (167°F)
25	Sunload sensor*2	Less than 48.84 W/m ² (42 kcal)	Greater than 1,640 W/m ² (1,410 kcal)
26	PBR*1	Greater than 50%	Less than 30%

*1: 50% and 30% refer to percentage with respect to full stroke of air mix door. (Full cold: 0%, Full hot: 100%)

*2: **Conduct self-diagnosis STEP 2 under sunny condition.**

When conducting indoors, direct light (more than 60W) at sunload sensor.

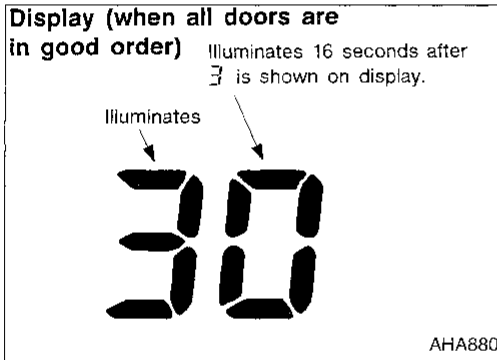

STEP 3: Checks mode door operation

Display shows 30 in STEP 3 mode.

When all doors are in good order, display will then show 30.

It takes approximately 16 seconds to check all mode and intake doors.

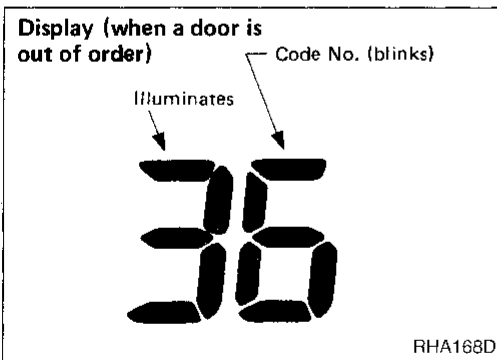

When abnormalities are detected, display shows a code No. corresponding with malfunctioning circuit, door position switch or motor.

Code No.	31	32	34	35	36	37	38	39
Malfunction	FACE	B/L	FOOT	F/D	DEF	REC	20% FRE	FRE

If any mode and intake door motor position switch is malfunctioning, mode and intake door motor will also malfunction.

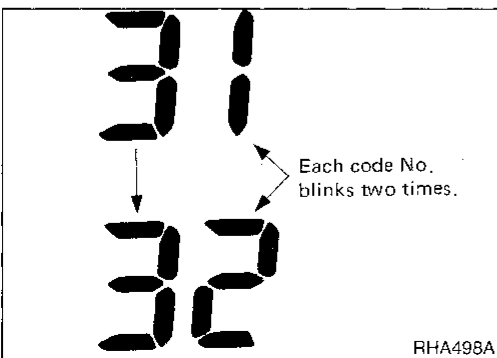

If two or more mode and intake doors are out of order, corresponding code numbers respectively blink two times.

Self-diagnosis (Cont'd)

STEP 4: Checks operation of each actuator

Start engine and run at operating temperature.

Display shows 41 in STEP 4 mode.

When DEF switch is pressed one time, display shows 42. Thereafter, each time the switch is pressed, display advances one number at a time, up to 46, then returns to 41.

The auto amplifier will forcefully transmit an output to the affected actuators in response to code No. shown on display, as indicated in table below.

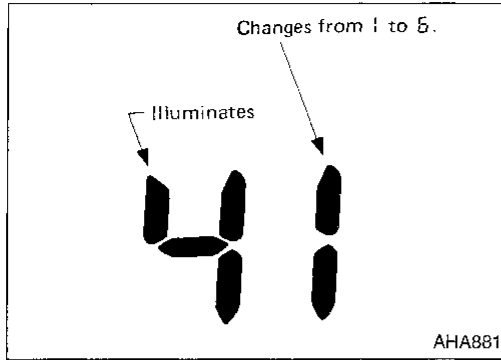

AHA881

Discharge air flow

Switch mode/ indicator	Air outlet/distribution		
	Face	Foot	Defrost
	100%	—	—
	60%	40%	—
	—	78%	22%
	—	55%	45%
	—	—	100%

AHA903

Checks must be made visually, by listening to any noise, or by touching air outlets with your hand, etc. for improper operation.

Operating condition of each actuator cannot be checked by indicators.

Actuator	Code No.					
	41	42	43	44	45	46
Mode door	FACE	B/L	B/L	FOOT	F/D	DEF
Intake door	REC	REC	20% FRE	FRE	FRE	FRE
Air mix door	Full Cold	Full Cold	Full Hot	Full Hot	Full Hot	Full Hot
Fresh vent door	OPEN	OPEN	CLOSE	CLOSE	CLOSE	CLOSE
Blower motor V	4 - 5	9 - 11	7 - 9	7 - 9	7 - 9	10 - 12
Compressor	ON	ON	ON	OFF	OFF	ON

STEP 5: Checks temperature detected by sensors

Display shows 5 in STEP 5 mode.

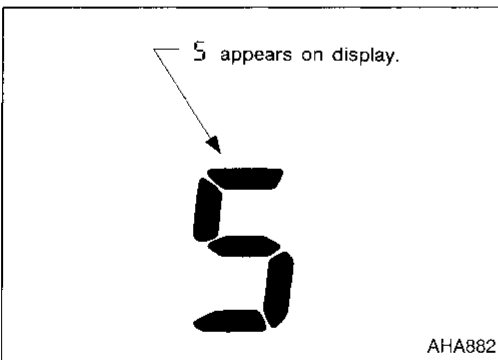

AHA882

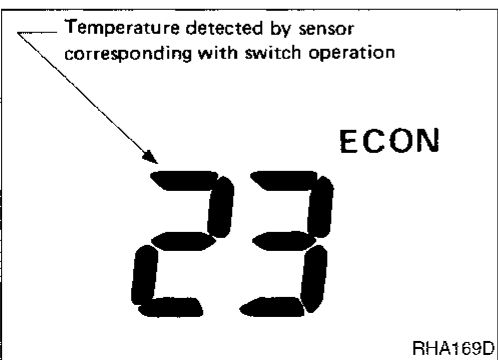

RHA169D

- When DEF switch is pressed one time, display shows temperature detected by ambient sensor.
- When DEF switch is pressed second time, display shows temperature detected by in-vehicle sensor.
- ECON indicates display shows negative temperature reading.
- When DEF switch is pressed third time, display returns to original presentation 5.

Self-diagnosis (Cont'd)

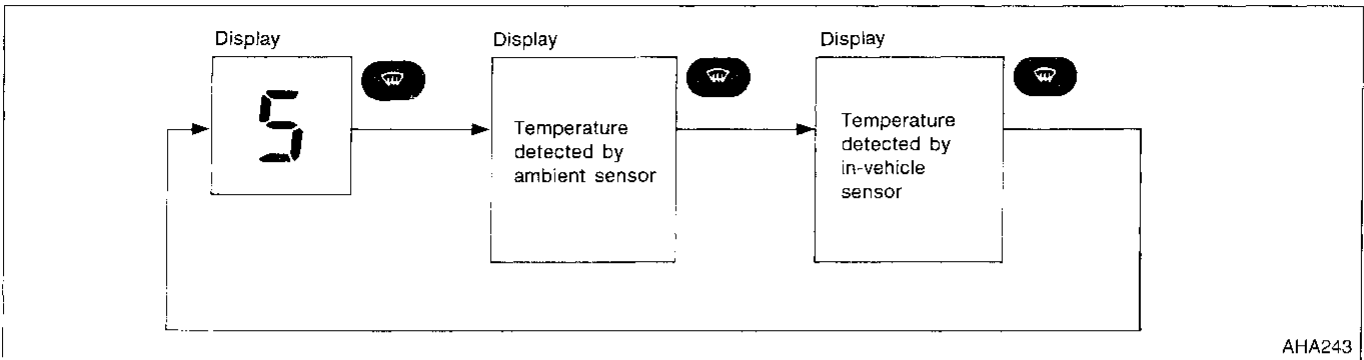



If temperature shown on display greatly differs from actual temperature: Check sensor circuit first, then inspect sensor itself according to the procedures described in **Control System Input Components**. Refer to HA-123.

Self-diagnosis (Cont'd)

AUXILIARY MECHANISM: Temperature setting trimmer

The trimmer compensates for differences in range of $\pm 3^{\circ}\text{C}$ ($\pm 6^{\circ}\text{F}$) between temperature setting (displayed digitally) and temperature felt by driver.

Operating procedures for this trimmer are as follows:

- Begin Self-diagnosis STEP 5 mode.
- Press  fan UP switch to set system in auxiliary mode.
- Press either  HOT or  COLD switch as desired. Temperature will change at a rate of 0.5°C (1°F) each time a switch is pressed.

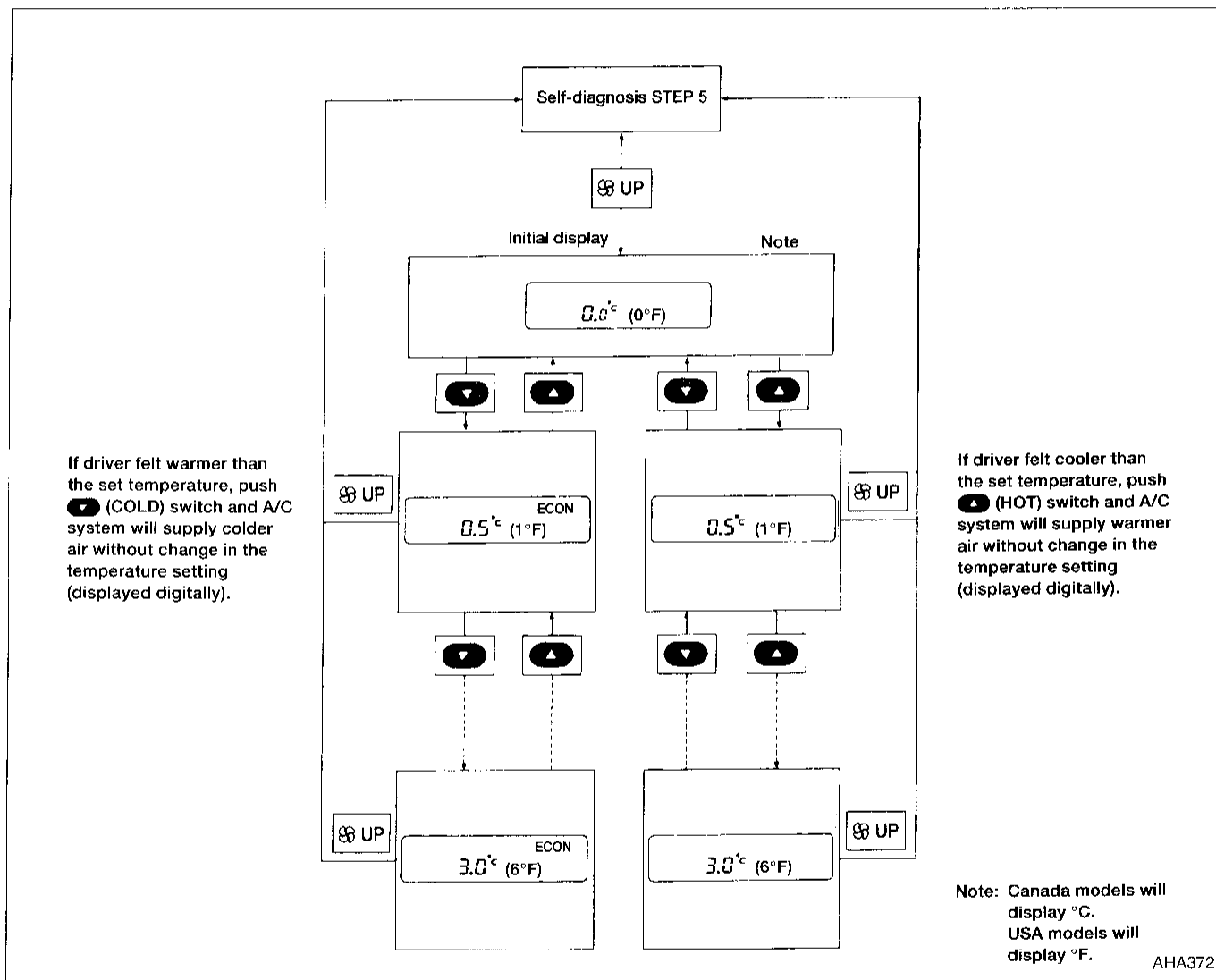

When battery cable is disconnected, trimmer operation is canceled. Temperature set becomes that of initial condition, i.e., 0°C (0°F).

Preliminary Check

PRELIMINARY CHECK 1

Air outlet does not change.

- Perform Self-diagnosis STEP 1 before referring to the flow chart.

CHECK SENSOR CIRCUIT.
Set up Self-diagnosis STEP 2.
Is each sensor circuit normal?
Code No. 20 should be indicated on the display after approx. 4 seconds.

No → Check sensor circuit in detail according to the diagnostic procedure below corresponding to each code No.

Code No.	How to repair
21	Go to Diagnostic Procedure 1. Refer to HA-103.
22	Go to Diagnostic Procedure 2. Refer to HA-104.
25	Go to Diagnostic Procedure 3. Refer to HA-105.
26	Go to Diagnostic Procedure 4. Refer to HA-106.
ECON 21	Go to Diagnostic Procedure 1. Refer to HA-103.
ECON 22	Go to Diagnostic Procedure 2. Refer to HA-104.
ECON 25	Go to Diagnostic Procedure 3. Refer to HA-105.
ECON 26	Go to Diagnostic Procedure 4. Refer to HA-106.

When malfunctioning sensor circuits for ambient sensor and in-vehicle sensor are suspected, it is useful to check temperature detected by each sensor. With Self-diagnosis STEP 5, confirm the temperature is within normal range before performing Diagnostic Procedures.

Yes

CHECK MODE DOOR MOTOR.
Set up Self-diagnosis STEP 3.
Is mode door motor operating normally?
Code No. 30 should be indicated on the display after approx. 16 seconds.

No → Go to **Diagnostic Procedure 5**. Refer to HA-107.

Yes

CHECK MODE DOOR OPERATION.
Set up Self-diagnosis STEP 4.
Does air outlet change according to each code No.?

41	42	43	44	45	46
FACE	B/L	B/L	FOOT	F/D	DEF

Refer to HA-75.

No → Check side link mechanism. Refer to HA-120.

NG → Repair or adjust.

OK

Go to **Diagnostic Procedure 5**. Refer to HA-107.

Yes

Air outlet control system is normal. Refer to HA-128.

Preliminary Check (Cont'd)

PRELIMINARY CHECK 2

Intake door does not change.

- Perform Self-diagnosis STEP 1 before referring to the following flow chart.

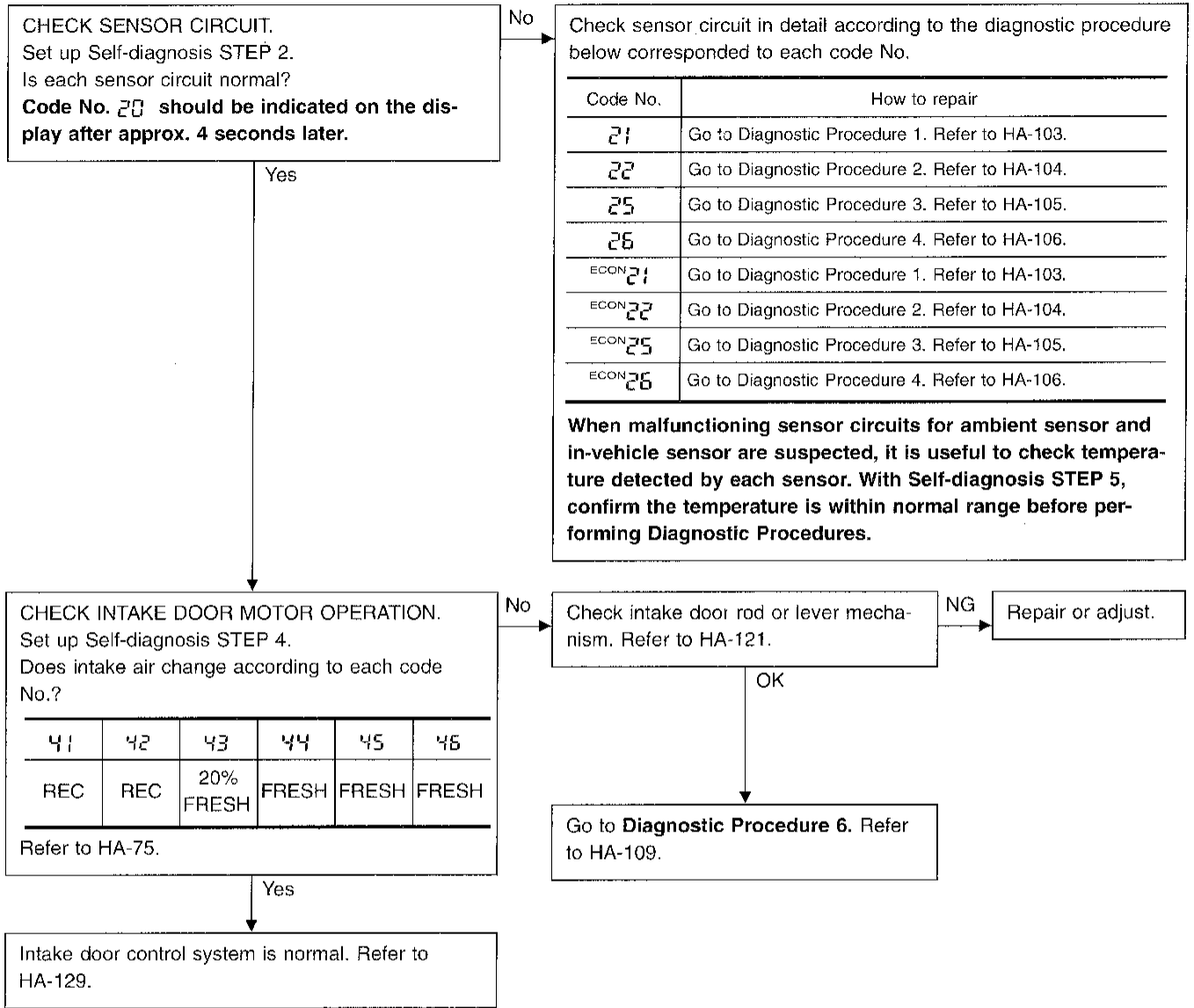

GI
MA
EM
LC
EC
FE
CL
MT
AT
FA
RA
BR
ST
RS
BT
HA
EL
DX

Preliminary Check (Cont'd)

PRELIMINARY CHECK 3

Insufficient cooling.

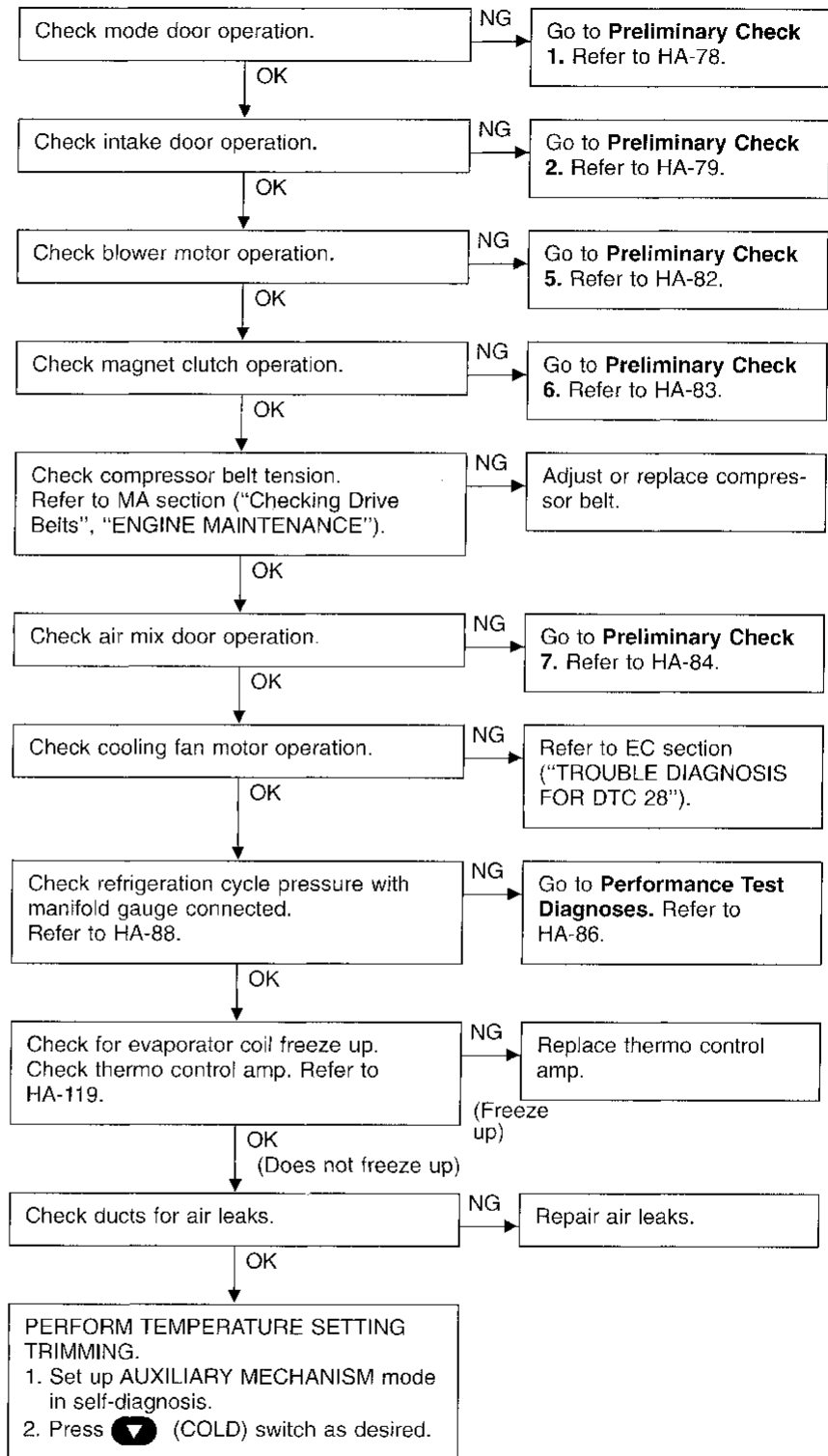

Preliminary Check (Cont'd)

PRELIMINARY CHECK 4

Insufficient heating.

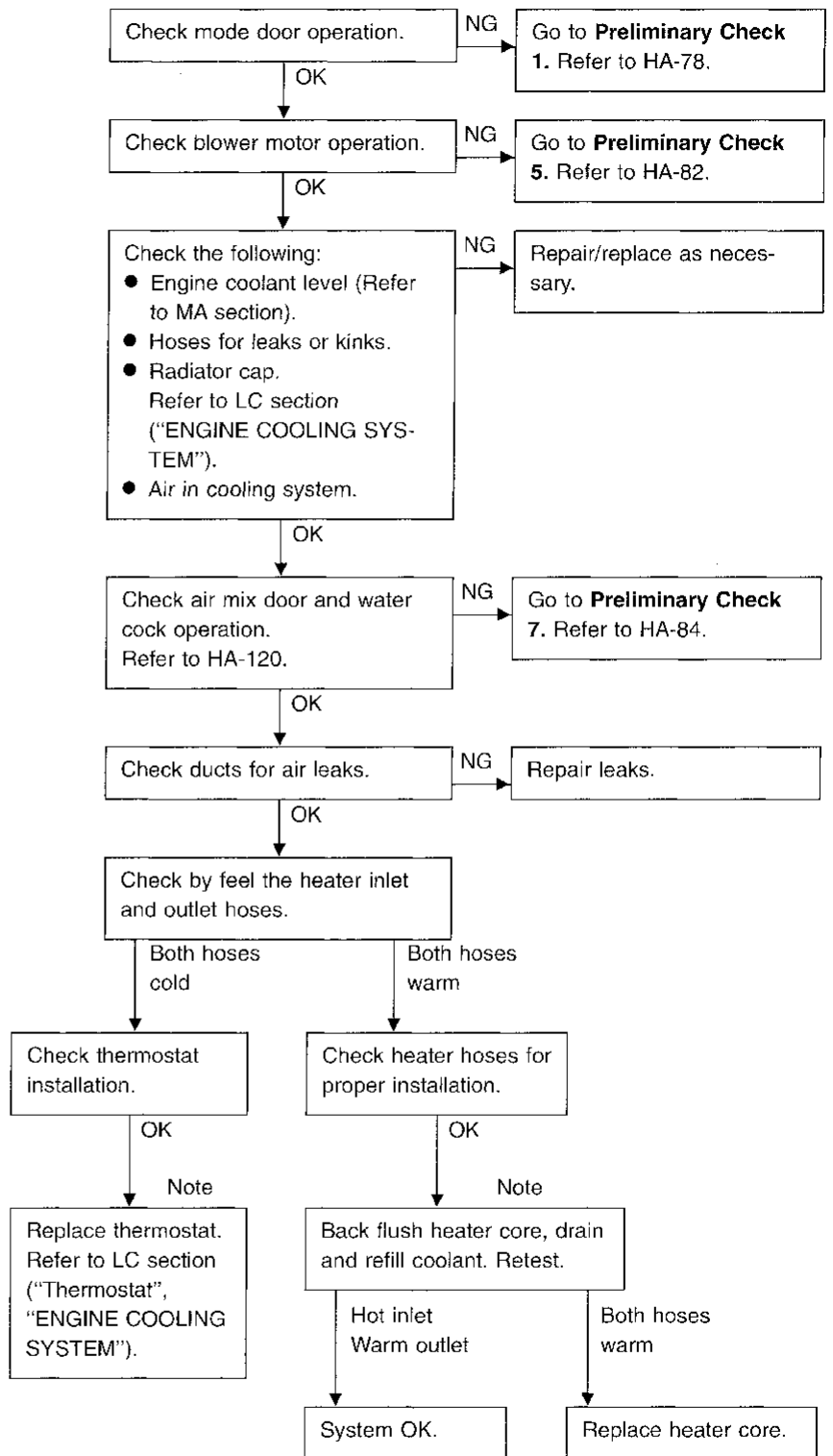

Note: To avoid unnecessary service of heating system, first perform TEMPERATURE SETTING TRIMMING. Refer to "AUXILIARY MECHANISM", "Self-diagnosis" HA-77.

Preliminary Check (Cont'd)

PRELIMINARY CHECK 5

Blower motor operation is malfunctioning.

- Perform Self-diagnosis STEP 1 before referring to the following flow chart.

CHECK SENSOR CIRCUIT.
Set up Self-diagnosis STEP 2.
Is each sensor circuit normal?
Code No. 20 should be indicated on the display after approx. 4 seconds.

No

Check sensor circuit in detail according to the diagnostic procedure below corresponding to each code No.

Code No.	How to repair
21	Go to Diagnostic Procedure 1. Refer to HA-103.
22	Go to Diagnostic Procedure 2. Refer to HA-104.
25	Go to Diagnostic Procedure 3. Refer to HA-105.
26	Go to Diagnostic Procedure 4. Refer to HA-106.
ECON 21	Go to Diagnostic Procedure 1. Refer to HA-103.
ECON 22	Go to Diagnostic Procedure 2. Refer to HA-104.
ECON 25	Go to Diagnostic Procedure 3. Refer to HA-105.
ECON 26	Go to Diagnostic Procedure 4. Refer to HA-106.

When malfunctioning sensor circuits for ambient sensor and in-vehicle sensor are suspected, it is useful to check temperature detected by each sensor. With Self-diagnosis STEP 5, confirm the temperature is within normal range before performing Diagnostic Procedures.

Yes

CHECK BLOWER MOTOR OPERATION.
Set up Self-diagnosis STEP 4.
Does blower motor speed change according to each code No.?

Code No.	41	42	43	44	45	46
Blower motor speed	Low	Middle high	Middle low		High	

No

Go to Diagnostic Procedure 9.
Refer to HA-112.

Yes

Is engine coolant temperature below 50°C (122°F) and ambient temperature below 15°C (59°F)?

No

Blower motor operation is normal.
Refer to HA-131.

Yes

Is blower motor operating under fan starting speed control?
Refer to HA-131.

No

Check thermal transmitter control circuit.
Refer to EL section ("Electrical Components Inspection", "TROUBLE DIAGNOSES").

Yes

Blower motor operation is normal.

Preliminary Check (Cont'd)

PRELIMINARY CHECK 6

Magnet clutch does not engage.

- Perform Self-diagnosis STEP 1 before referring to the following flow chart.

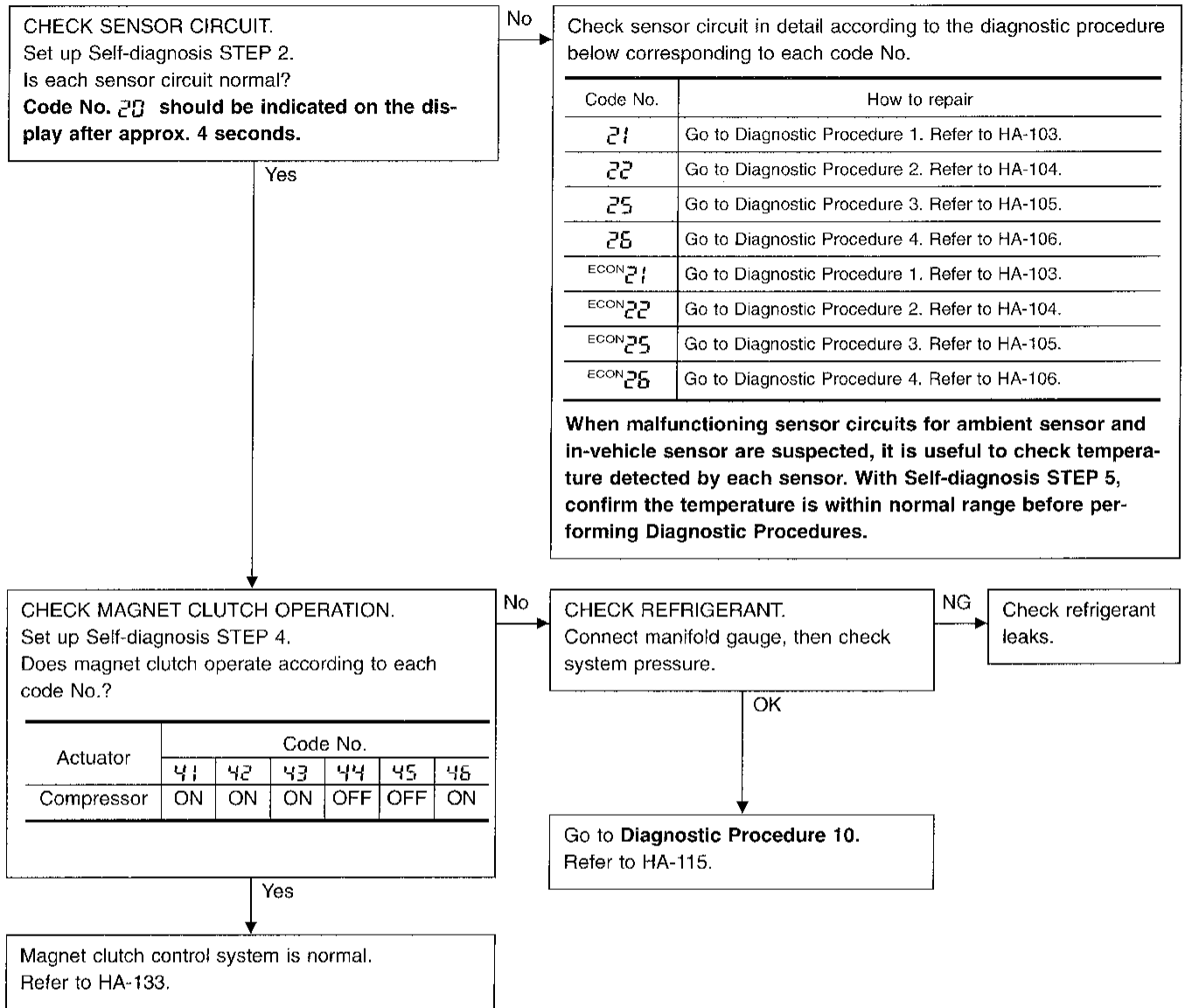

GI
MA
EM
LC
FC
FE
CL
MT
AT
FA
RA
BR
ST
RS
BT
HA
EL
IDX

Preliminary Check (Cont'd)

PRELIMINARY CHECK 7

Discharged air temperature does not change.

- Perform Self-diagnosis STEP 1 before referring to the following flow chart.

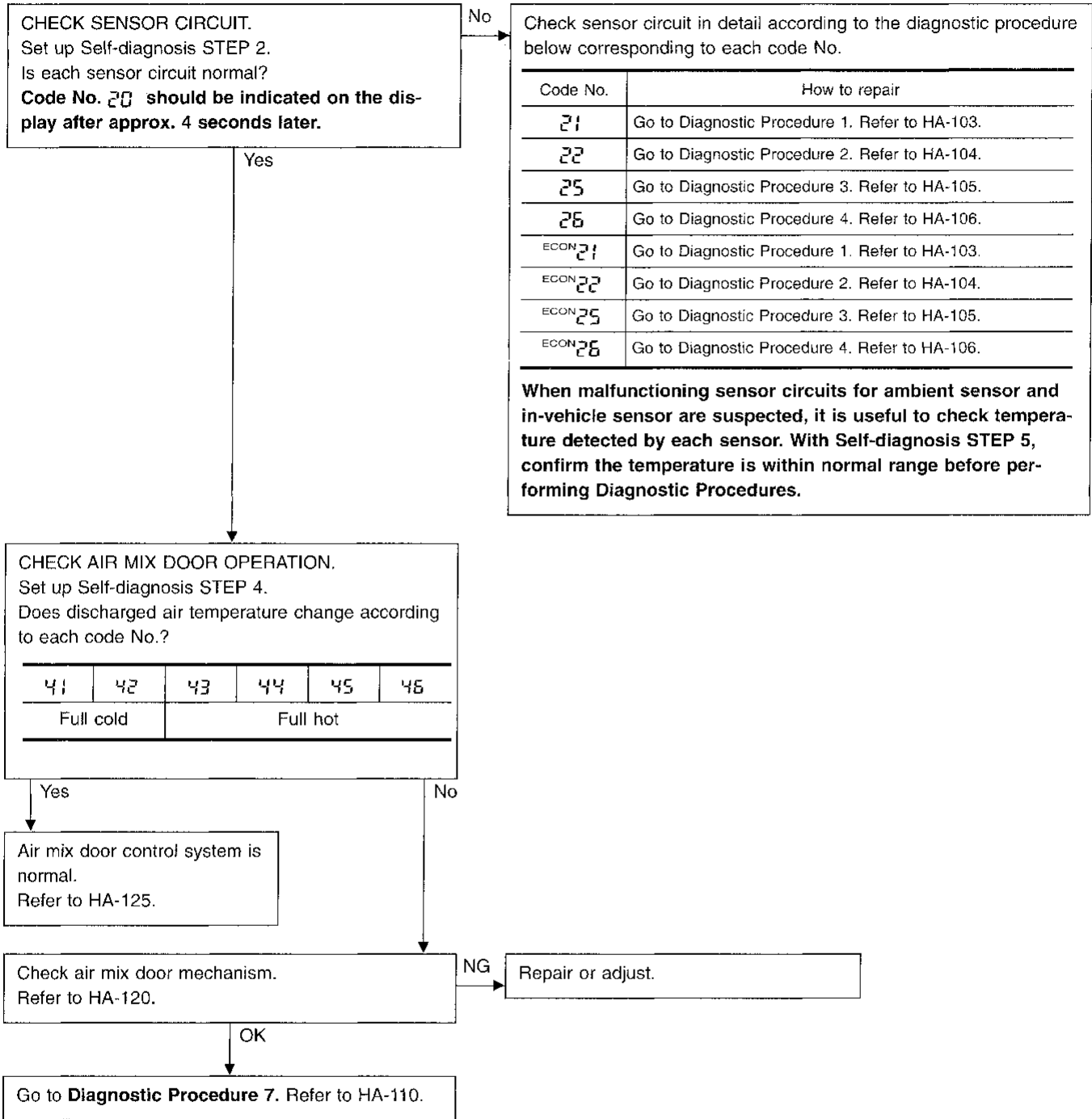

Preliminary Check (Cont'd)

PRELIMINARY CHECK 8

Noise.

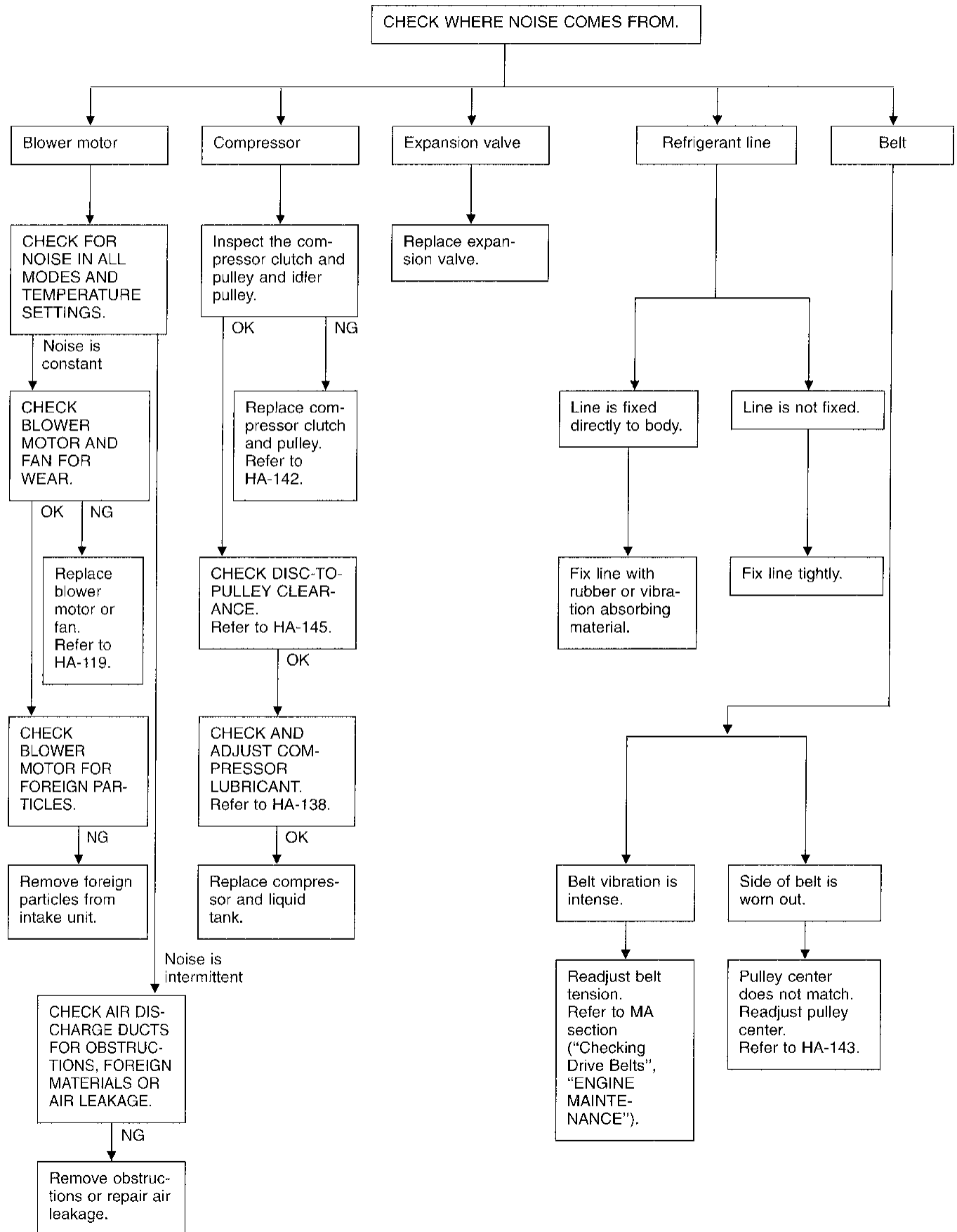

GI
WA
EM
IG
EC
FE
CL
MT
AT
FA
PA
BR
ST
PS
BT
HA
EL
DX

Performance Test Diagnoses

INSUFFICIENT COOLING

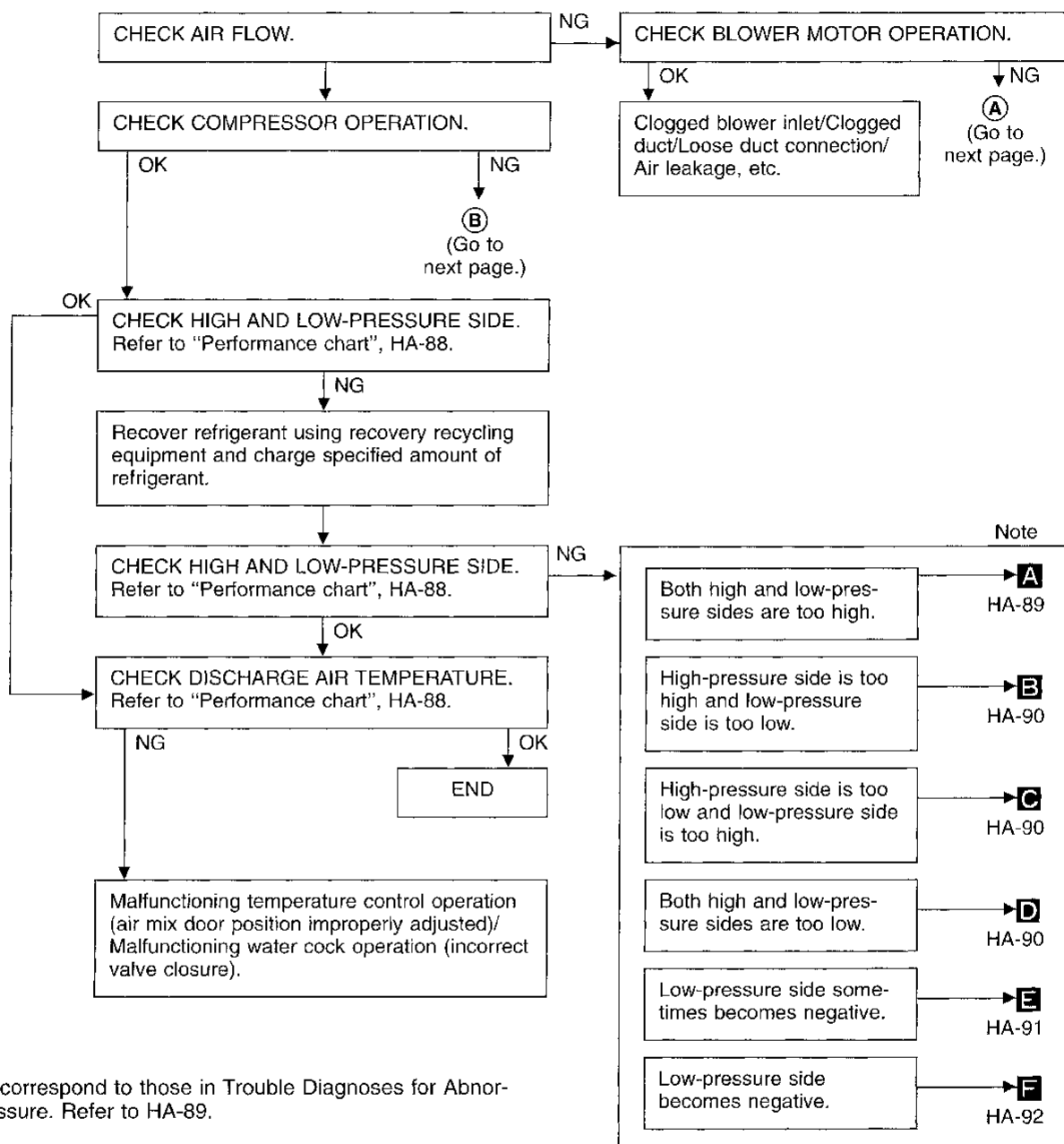

Note: **A-F** correspond to those in Trouble Diagnoses for Abnormal Pressure. Refer to HA-89.

Performance Test Diagnoses (Cont'd)

GI
MA
EW
LC
EC
FE
CL
MT
AT
FA
RA
BR
ST
RS
BT
HA
EL
IDX

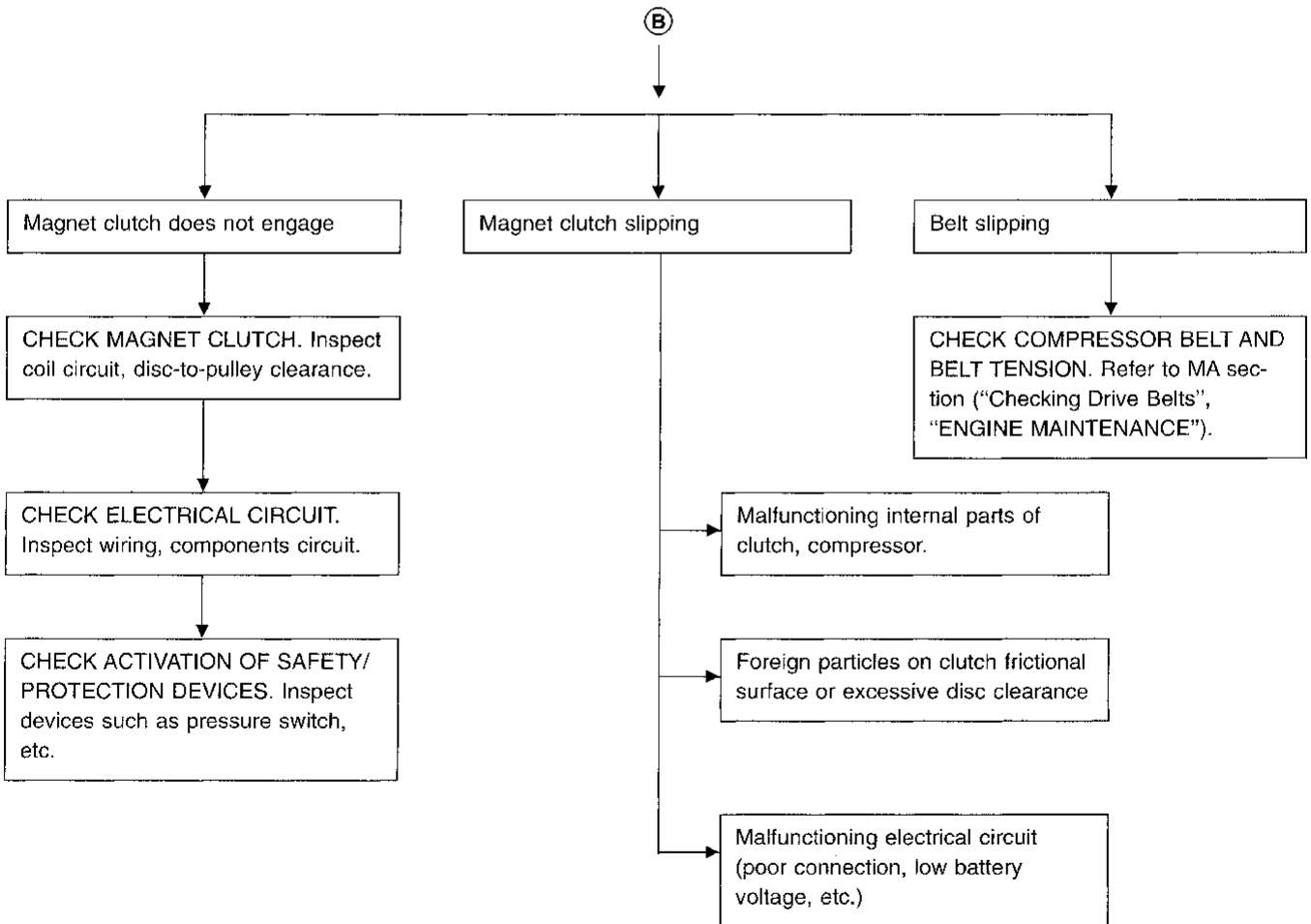
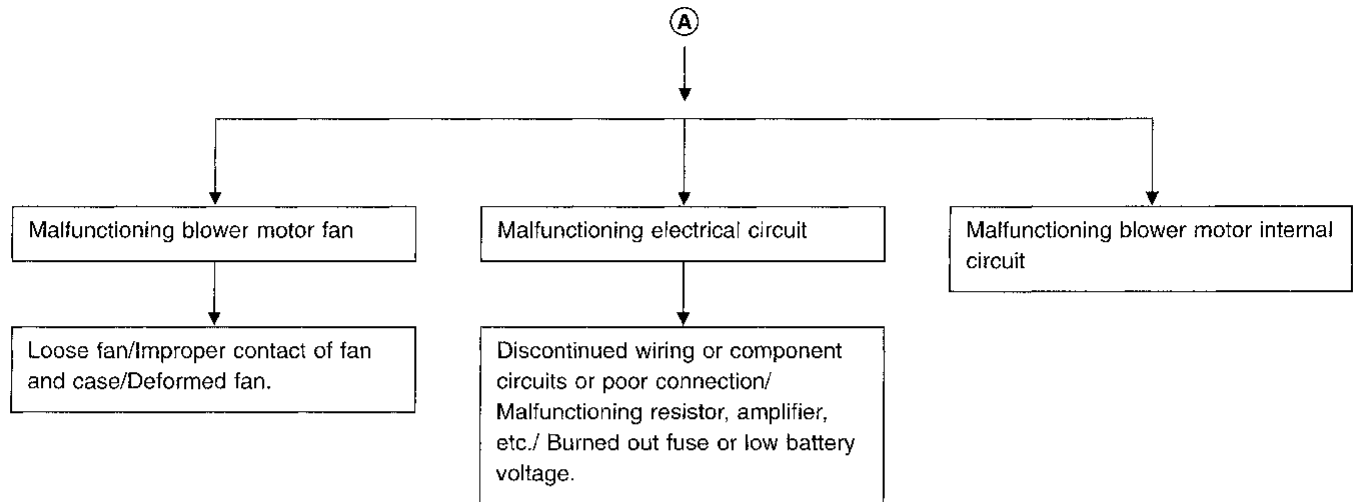

Performance Chart

TEST CONDITION

Before conducting performance test, disconnect ambient sensor harness connector and connect a jumper cable across harness terminal.

Testing must be performed as follows:

- Vehicle location: Indoors or in the shade (in a well ventilated place)
 - Doors: Closed
 - Door window: Open
 - Hood: Open
 - TEMP. setting: 18°C (65°F)
 - AUTO switch: ON
 - REC switch: (Recirculation) ON
 - Fan speed: MAX.
 - Engine speed: 1,500 rpm
- Operate the air conditioner system for 10 minutes before taking measurements.

TEST READING

Recirculating-to-discharge air temperature table

Inside air at blower assembly inlet for recirculation*		Discharge air temperature at center ventilator °C (°F)
Relative humidity %	Air temperature °C (°F)	
50 - 60	20 (68)	4.0 - 5.4 (39 - 42)
	25 (77)	4.2 - 5.6 (40 - 42)
	30 (86)	8.5 - 11.1 (47 - 52)
	35 (95)	13.5 - 16.7 (56 - 62)
	40 (104)	18.5 - 22.3 (65 - 72)
60 - 70	20 (68)	5.4 - 6.8 (42 - 44)
	25 (77)	5.6 - 8.0 (42 - 46)
	30 (86)	11.1 - 14.1 (52 - 57)
	35 (95)	16.7 - 20.3 (62 - 69)
	40 (104)	22.3 - 26.5 (72 - 80)

* Thermometer should be placed at intake unit RH side of instrument panel.

Ambient air temperature-to-operating pressure table

Ambient air		High-pressure (Discharge side) kPa (kg/cm ² , psi)	Low-pressure (Suction side) kPa (kg/cm ² , psi)
Relative humidity %	Air temperature °C (°F)		
50 - 70	20 (68)	834 - 1,098 (8.5 - 11.2, 121 - 159)	122.6 - 161.8 (1.25 - 1.65, 17.8 - 23.5)
	25 (77)	1,049 - 1,363 (10.7 - 13.9, 152 - 198)	137.3 - 181.4 (1.4 - 1.85, 19.9 - 26.3)
	30 (86)	1,226 - 1,618 (12.5 - 16.5, 178 - 235)	152.0 - 201.0 (1.55 - 2.05, 22.0 - 29.2)
	35 (95)	1,255 - 1,716 (12.8 - 17.5, 182 - 249)	166.7 - 230.5 (1.7 - 2.35, 24.2 - 33.4)
	40 (104)	1,540 - 2,030 (15.7 - 20.7, 223 - 294)	201.0 - 289.3 (2.05 - 2.95, 29.2 - 41.9)

If pressure is not within range, refer to HA-89 "Trouble Diagnoses for Abnormal Pressure".

Trouble Diagnoses for Abnormal Pressure

Whenever system's high or low-side pressure is abnormal, diagnose using a manifold gauge. The marker above the gauge scale in the following table indicates the standard normal pressure range. Since the standard (normal) pressure, differs from vehicle to vehicle, refer to HA-88 "Ambient air temperature-to-operating pressure table".

Pressure measurements are effective only when ambient temperature is in the range indicated under the Performance Chart.

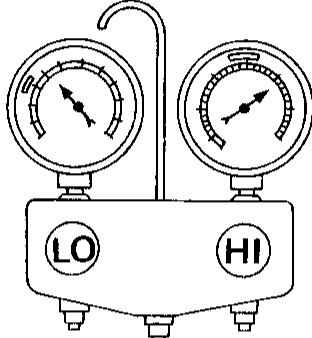
Gauge indication	Refrigerant cycle	Probable cause	Corrective action
<p>Both high and low-pressure sides are too high.</p> <p>A</p>  <p>AC359A</p>	<ul style="list-style-type: none"> ● Pressure is reduced soon after water is splashed on condenser. 	<p>Excessive refrigerant charge in refrigeration cycle.</p>	<p>Reduce refrigerant until specified pressure is obtained.</p>
	<p>Air suction by radiator or cooling fan is insufficient.</p>	<p>Insufficient condenser cooling performance.</p> <p>↓</p> <p>① Condenser fins are clogged.</p> <p>② Improper rotation of cooling fan.</p>	<ul style="list-style-type: none"> ● Clean condenser. ● Check and repair radiator or cooling fan as necessary.
	<ul style="list-style-type: none"> ● Low-pressure pipe is not cold. ● When compressor is stopped high-pressure value quickly drops by approximately 196 kPa (2 kg/cm², 28 psi). It then decreases gradually thereafter. 	<p>Poor heat exchange in condenser.</p> <p>(After compressor operation stops, high pressure decreases too slowly.)</p> <p>↓</p> <p>Air in refrigeration cycle.</p>	<p>Evacuate repeatedly and recharge system.</p>
	<p>Engine tends to overheat.</p>	<p>Engine cooling systems malfunction.</p>	<p>Check and repair each engine cooling system.</p>
	<ul style="list-style-type: none"> ● An area of the low-pressure pipe is colder than near the evaporator outlet. ● Plates are sometimes covered with frost. 	<ul style="list-style-type: none"> ● Excessive liquid refrigerant on low-pressure side. ● Excessive refrigerant discharge flow. ● Expansion valve is open a little compared with the specification. <p>↓</p> <p>① Improper thermal valve installation.</p> <p>② Improper expansion valve adjustment.</p>	<p>Replace expansion valve.</p>

Trouble Diagnoses for Abnormal Pressure
(Cont'd)

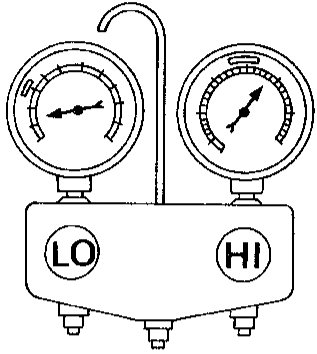
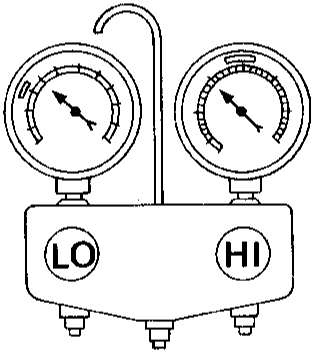
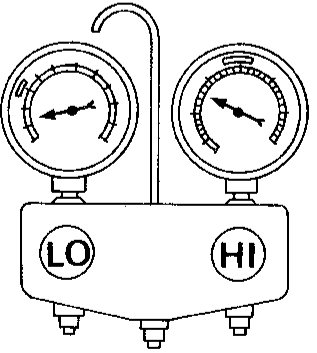
Gauge indication	Refrigerant cycle	Probable cause	Corrective action
<p>High-pressure side is too high and low-pressure side is too low.</p> <p>B</p>  <p>AC360A</p>	<p>Upper side of condenser and high-pressure side are hot, however, liquid tank is not as hot.</p>	<p>High-pressure tube or parts located between compressor and condenser are clogged or crushed.</p>	<ul style="list-style-type: none"> ● Check and repair or replace malfunctioning parts. ● Check lubricant for contamination.
<p>High-pressure side is too low and low-pressure side is too high.</p> <p>C</p>  <p>AC356A</p>	<p>High and low-pressure sides become equal soon after compressor operation stops.</p>	<p>Compressor pressure operation is improper.</p> <p style="text-align: center;">↓</p> <p>Damaged inside compressor packings.</p>	<p>Replace compressor.</p>
<p>Both high and low-pressure sides are too low.</p> <p>D</p>  <p>AC353A</p>	<ul style="list-style-type: none"> ● There is a big temperature difference between liquid tank outlet and inlet. Outlet temperature is extremely low. ● Liquid tank inlet and expansion valve are frosted. 	<p>Liquid tank is partly clogged.</p>	<ul style="list-style-type: none"> ● Replace liquid tank. ● Check lubricant for contamination.
	<ul style="list-style-type: none"> ● Temperature of expansion valve inlet is extremely low as compared with areas near liquid tank. ● Expansion valve inlet may be frosted. ● Temperature difference occurs somewhere in high-pressure side. 	<p>High-pressure pipe located between liquid tank and expansion valve is clogged.</p>	<ul style="list-style-type: none"> ● Check and repair malfunctioning parts. ● Check lubricant for contamination.
	<ul style="list-style-type: none"> ● Expansion valve and liquid tank are warm or only cool to the touch. 	<p>Low refrigerant charge.</p> <p style="text-align: center;">↓</p> <p>Leaking fittings or components.</p>	<ul style="list-style-type: none"> ● Check for refrigerant leaks. Refer to "Checking Refrigerant Leaks", HA-134.

Trouble Diagnoses for Abnormal Pressure (Cont'd)

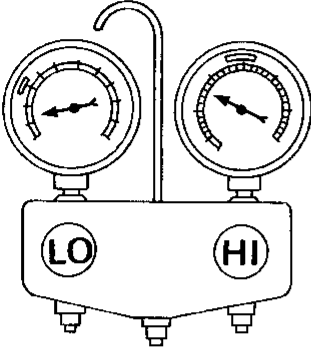
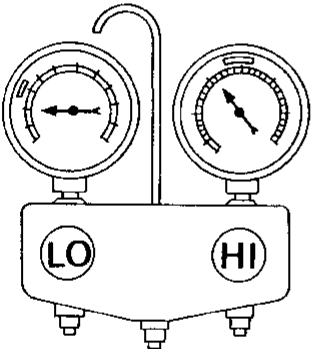
Gauge indication	Refrigerant cycle	Probable cause	Corrective action
<p>Both high and low-pressure sides are too low.</p> <p>D</p>  <p>AC353A</p>	<p>There is a big temperature difference between expansion valve inlet and outlet while the valve itself is frosted.</p>	<p>Expansion valve closed and past the specification.</p> <p>↓</p> <p>① Improper expansion valve adjustment.</p> <p>② Malfunctioning thermal valve.</p> <p>③ Outlet and inlet may be clogged.</p>	<ul style="list-style-type: none"> Remove foreign particles by using compressed air. Check lubricant for contamination.
	<p>An area of low-pressure pipe is colder than areas near the evaporator outlet.</p>	<p>Low-pressure pipe is clogged or crushed.</p>	<ul style="list-style-type: none"> Check and repair malfunctioning parts. Check lubricant for contamination.
	<p>Air flow volume is not enough or is too low.</p>	<p>Evaporator is frozen.</p> <p>↓</p> <p>Compressor discharge capacity does not change. (Compressor stroke is set at maximum length.)</p>	<p>Replace compressor.</p>
<p>Low-pressure side sometimes becomes negative.</p> <p>E</p>  <p>AC354A</p>	<ul style="list-style-type: none"> Air conditioner system does not function and does not cyclically cool the compartment air. The system constantly functions for a certain period of time after compressor is stopped and restarted. 	<p>Refrigerant does not discharge cyclically.</p> <p>↓</p> <p>Moisture is frozen at expansion valve outlet and inlet.</p> <p>↓</p> <p>Water is mixed with refrigerant.</p>	<ul style="list-style-type: none"> Replace refrigerant. Replace liquid tank.

GI
MA
EM
LC
EC
FE
CL
MT
AT
FA
PA
BR
ST
RS
ET
HA
EL
HX

Trouble Diagnoses for Abnormal Pressure
(Cont'd)

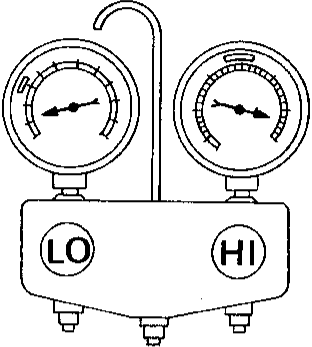
Gauge indication	Refrigerant cycle	Probable cause	Corrective action
<p>Low-pressure side becomes negative.</p> <p>F</p>  <p>AC362A</p>	<p>Liquid tank or front/rear side of expansion valve's pipe is frosted or dewed.</p>	<p>High-pressure side is closed and refrigerant does not flow.</p> <p style="text-align: center;">↓</p> <p>Expansion valve or liquid tank is frosted.</p>	<p>Leave the system at rest until no frost is present. Start it again to check whether or not the problem is caused by water or foreign particles.</p> <ul style="list-style-type: none"> ● If water is the cause, initially cooling is okay. Then the water freezes causing a blockage. ● Replace refrigerant. ● If due to foreign particles, remove expansion valve and remove particles with dry, compressed air. ● If either of the above methods cannot correct the problem, replace expansion valve. ● Replace liquid tank. ● Check lubricant for contamination.

Harness Layout

Engine compartment

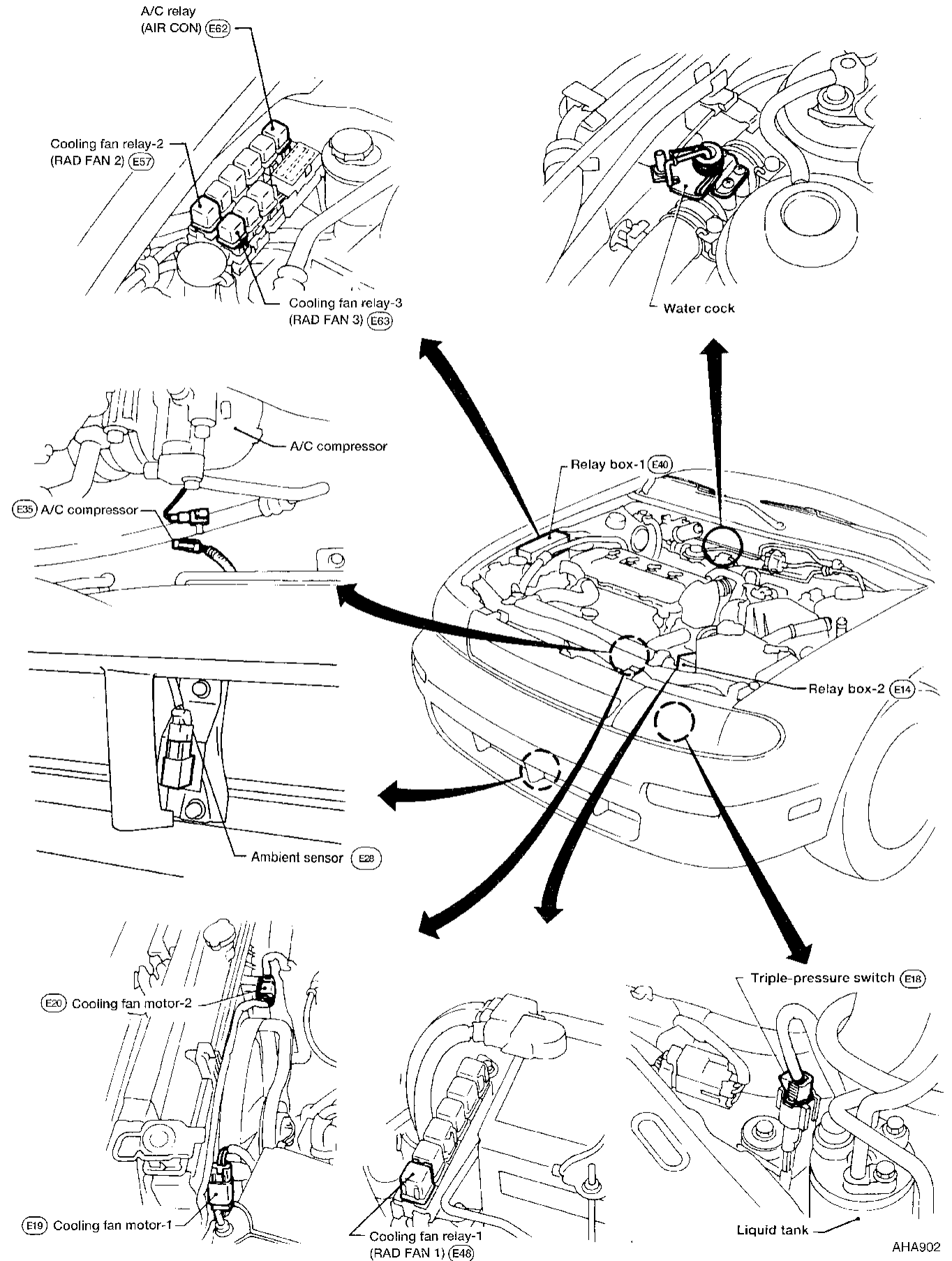

GI
MA
FW
LC
EC
FE
CL
MT
AT
FA
PA
BR
ST
HS
BT
HA
EL
DX

Harness Layout (Cont'd)

Passenger compartment

A In-vehicle sensor

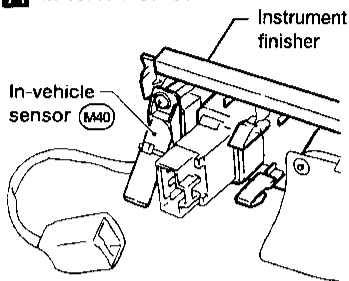

B Auto amp.

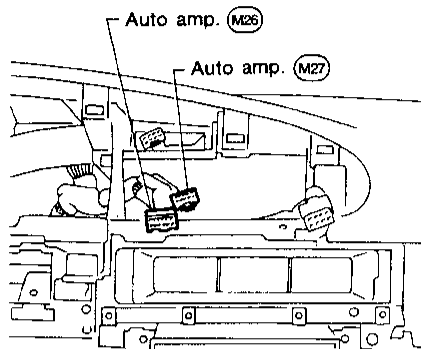

C Sunload sensor

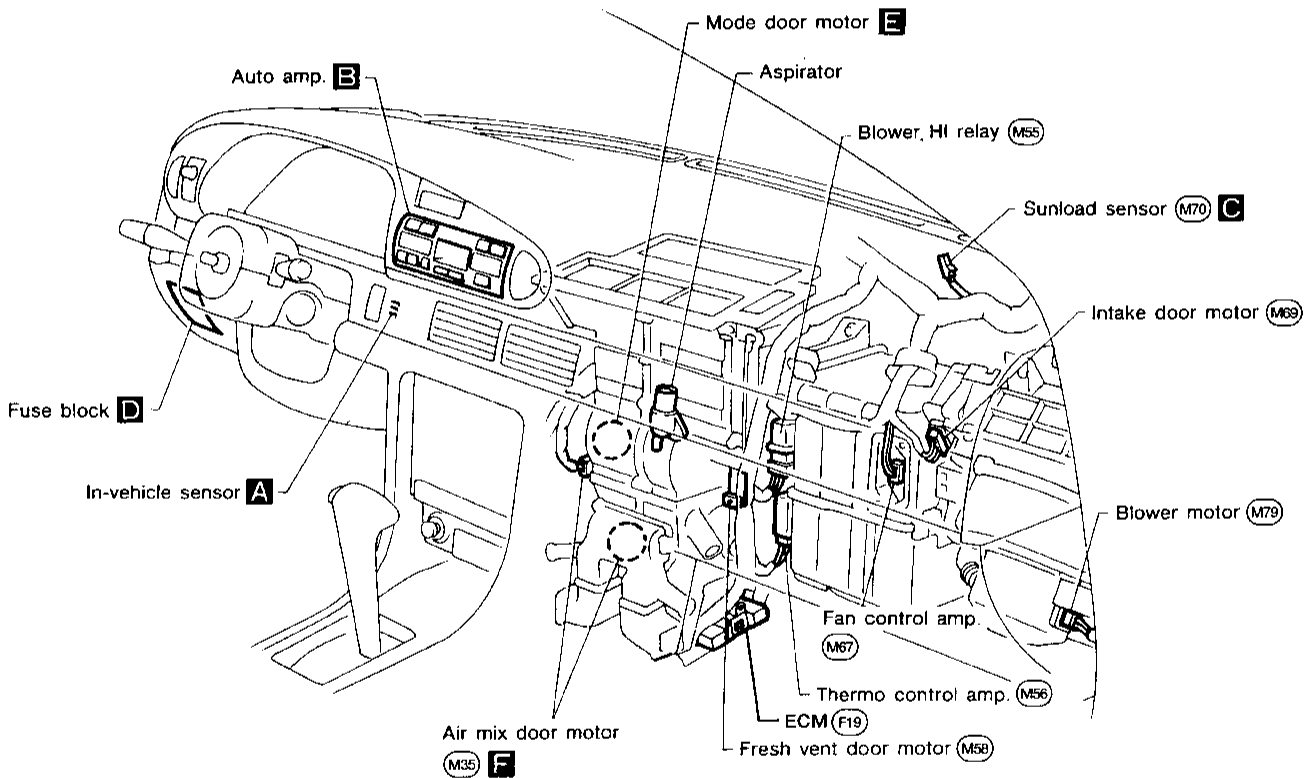
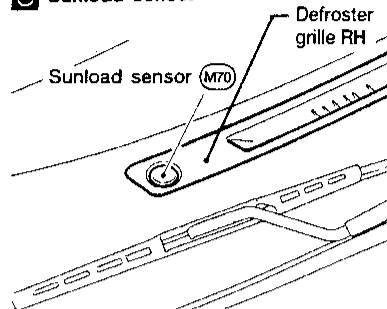

D Fuse block

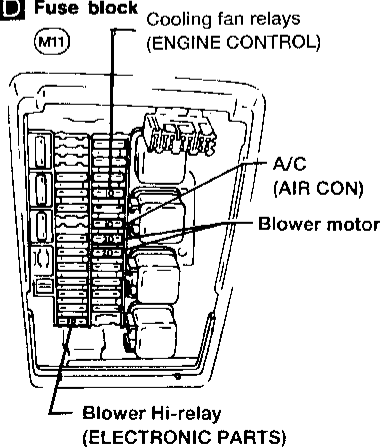

E Mode door motor

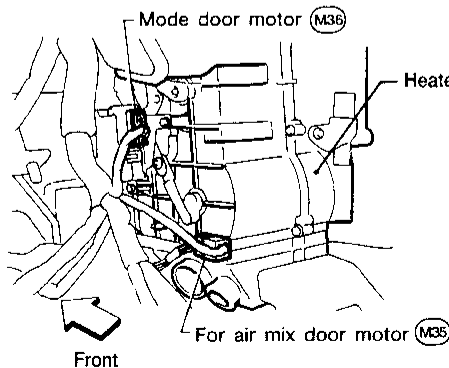

F Air mix door motor (Bottom of heater unit)

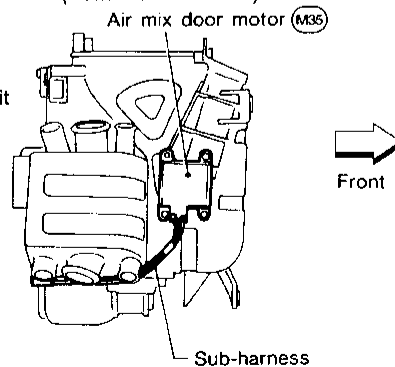

Circuit Diagram

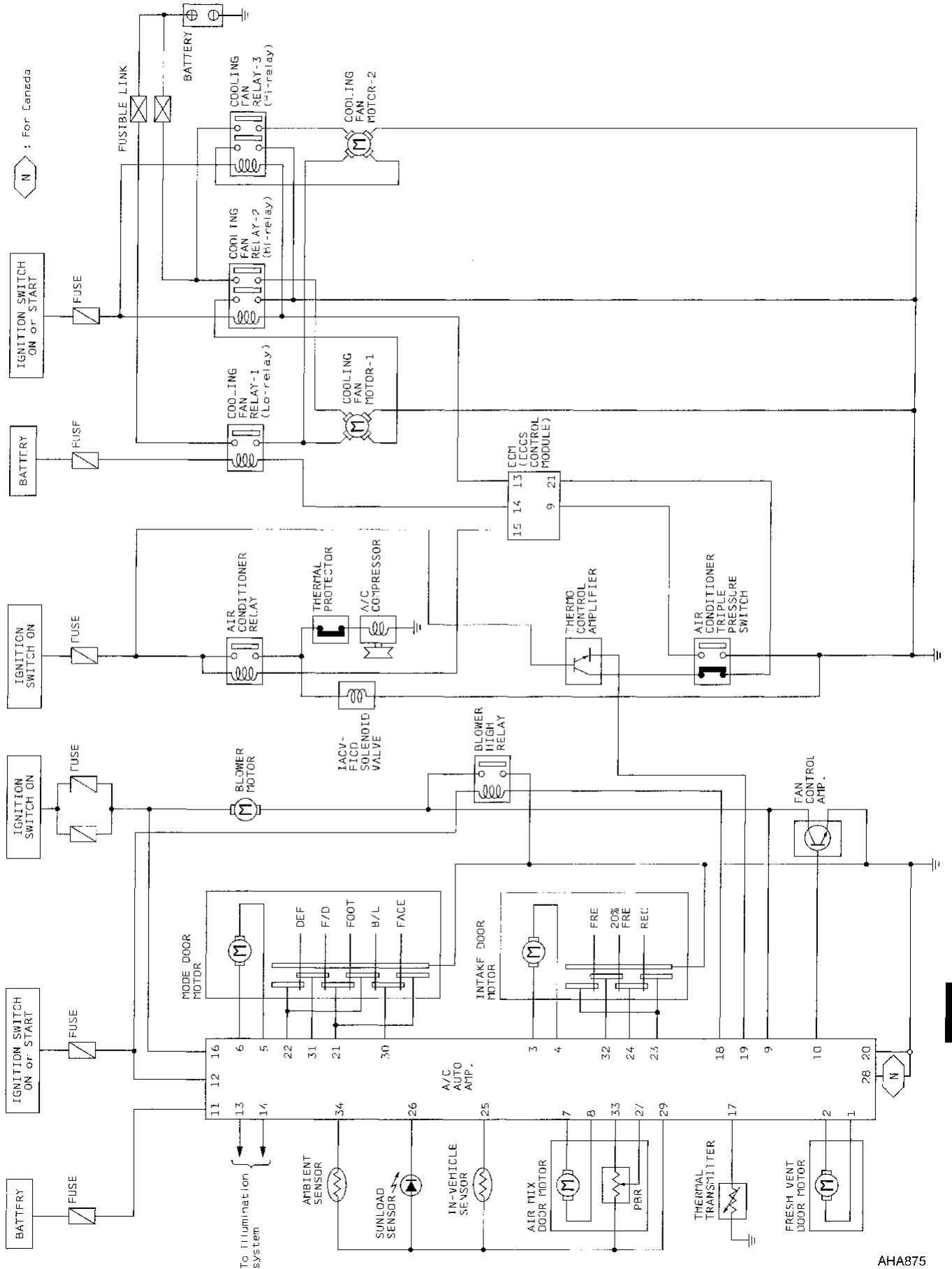

AHA875

Wiring Diagram -A/C, A-

HA-A/C,A-01

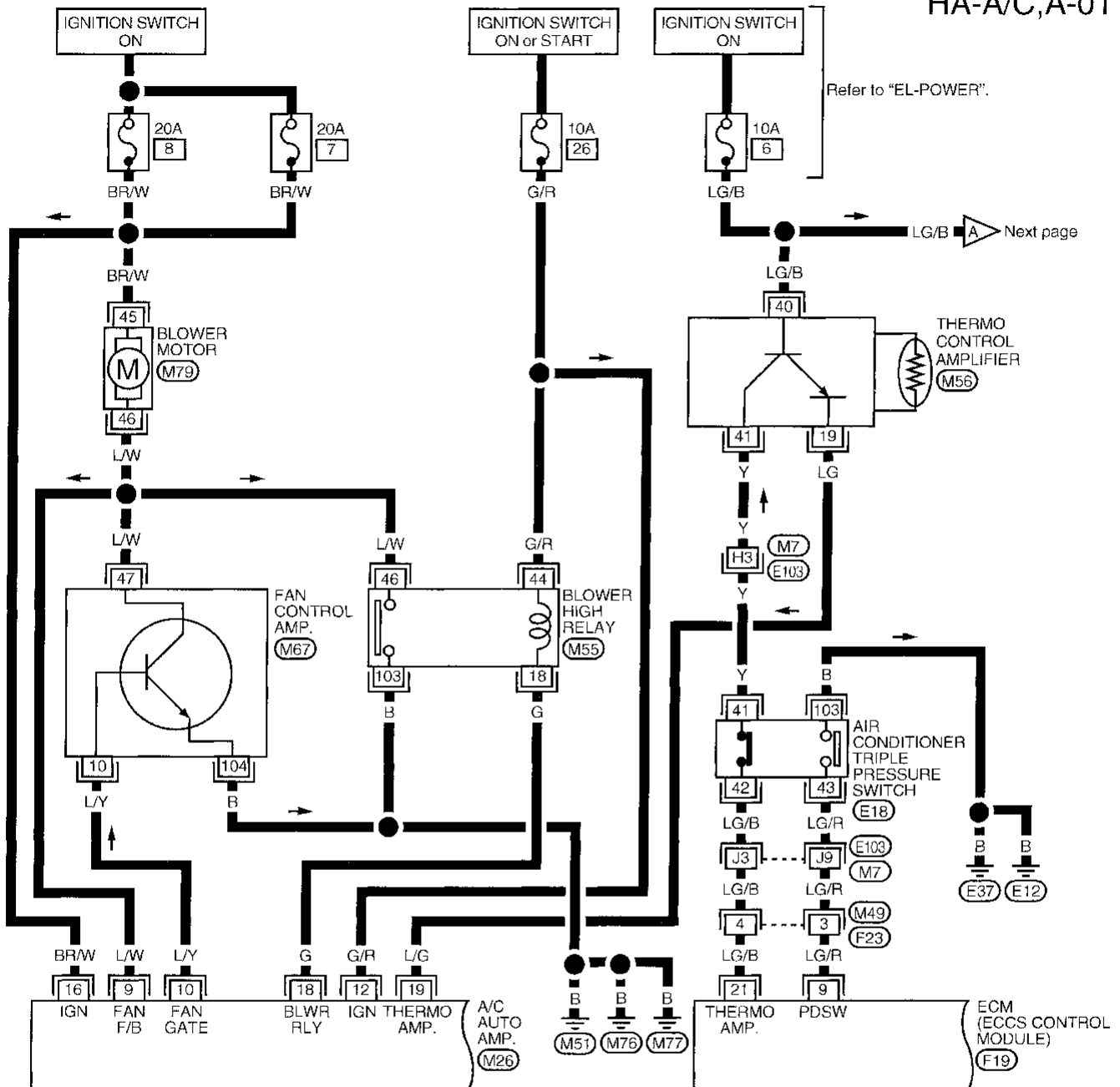

Refer to "EL-POWER".

Next page

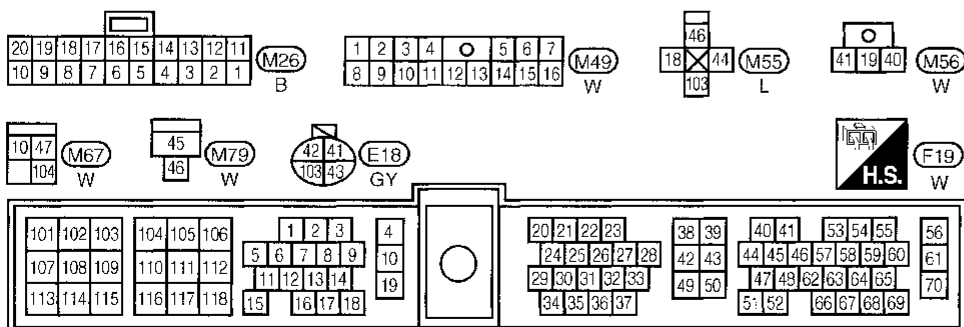

Refer to last page (Foldout page).

(M7, E103)

Wiring Diagram -A/C, A- (Cont'd)

HA-A/C,A-02

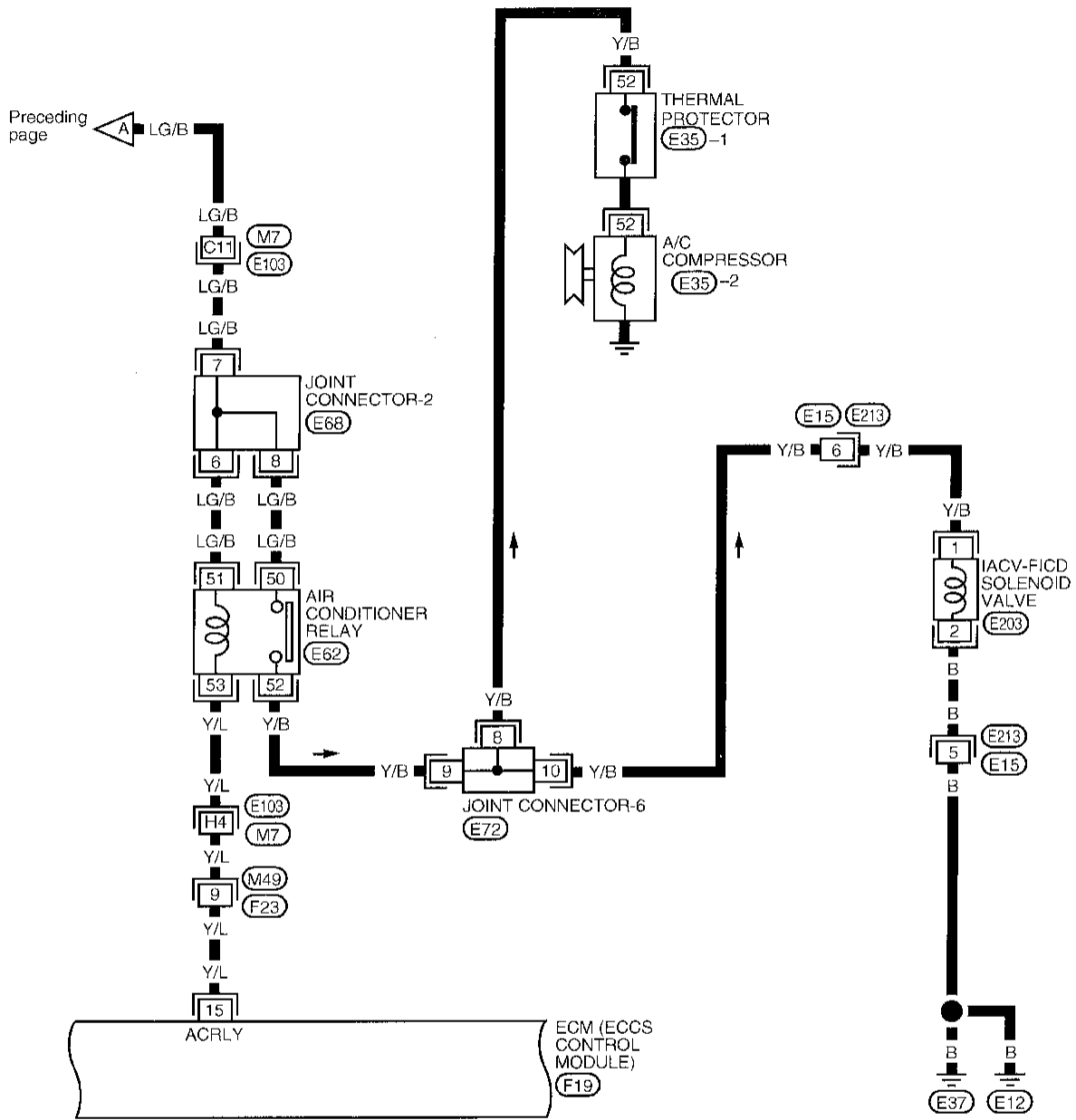

GI
KA
EM
LC
FC
FE
CL
MT
AT
FA
BA
BR
ST
RS
BI

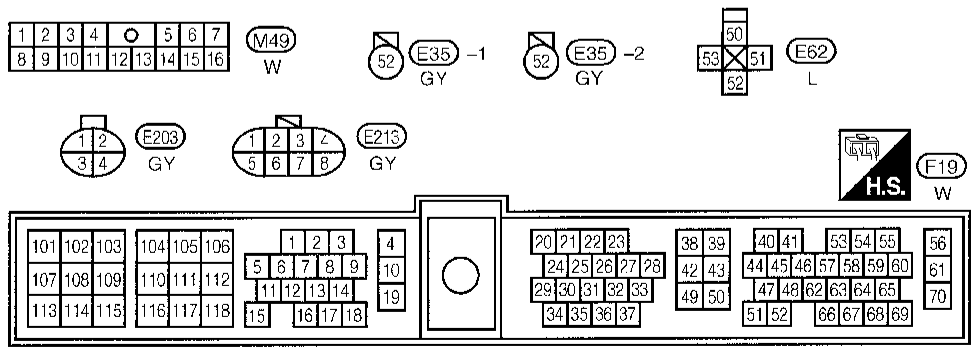

Refer to last page (Foldout page).
 (M7), (E103)
 (E68)
 (E72)

HA
EL
DX

Wiring Diagram -A/C, A- (Cont'd)

HA-A/C,A-03

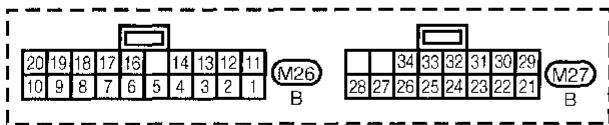
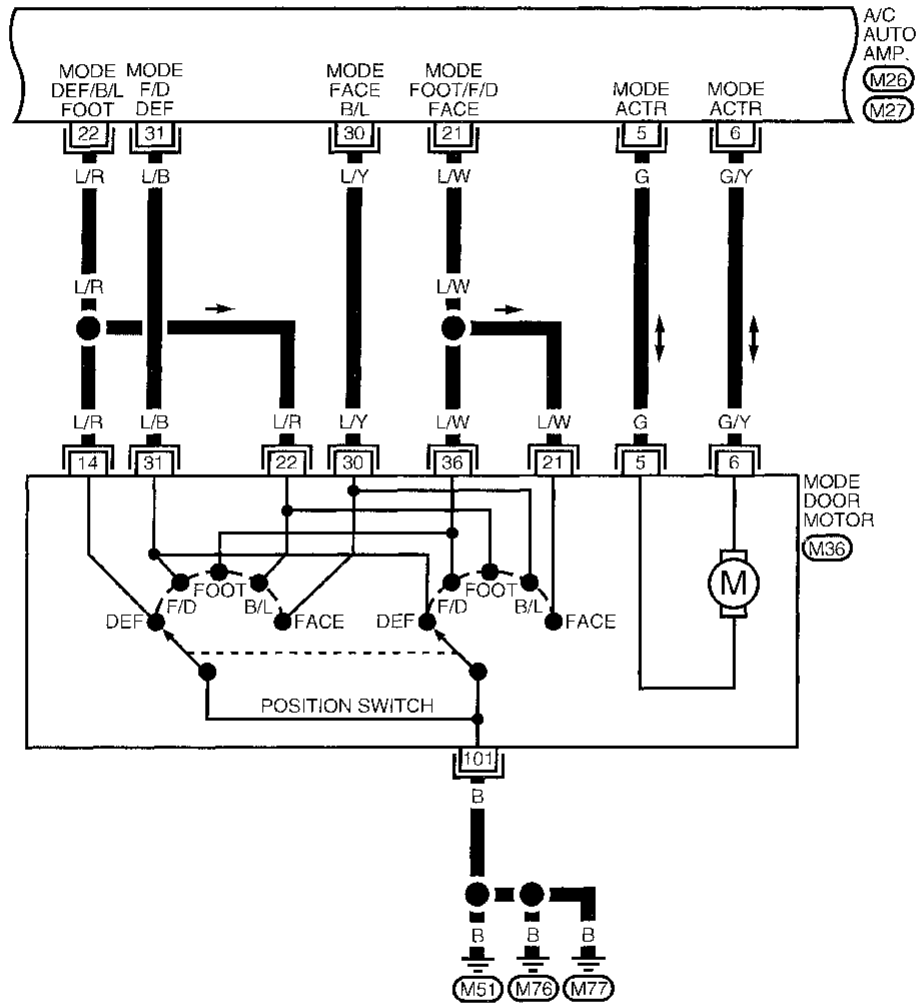

Wiring Diagram -A/C, A- (Cont'd)

HA-A/C,A-04

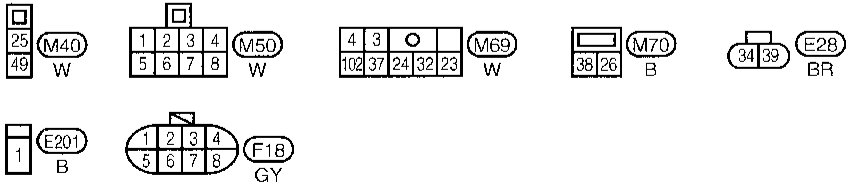
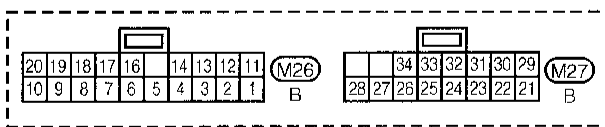
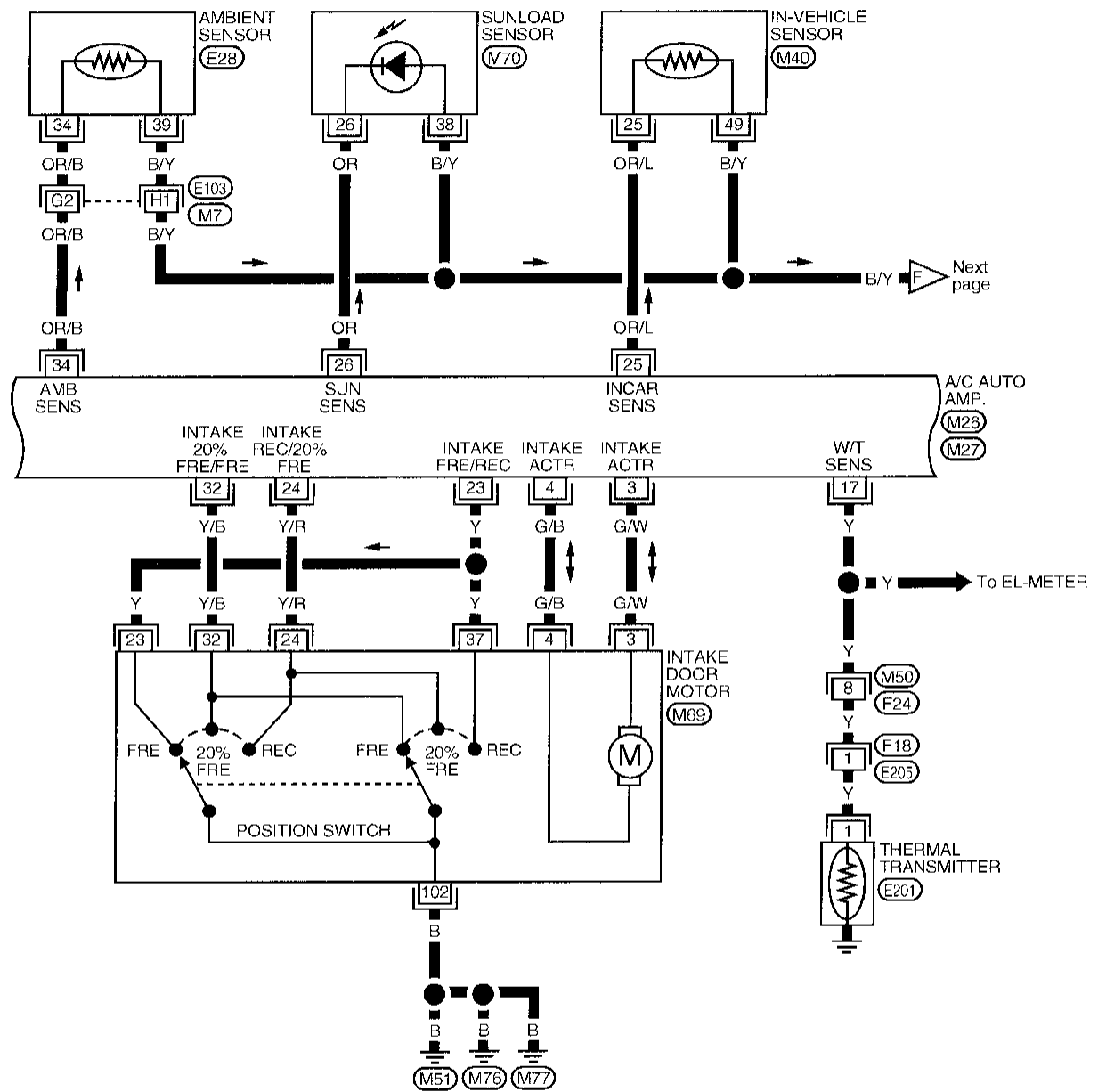

Refer to last page (Foldout page).

M7 E103

GI
MA
EM
LC
EC
FE
CL
MT
AT
FA
RA
BR
ST
RS
BT

HA

EL

JDX

Wiring Diagram -A/C, A- (Cont'd)

HA-A/C,A-05

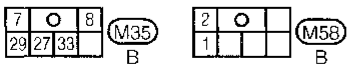
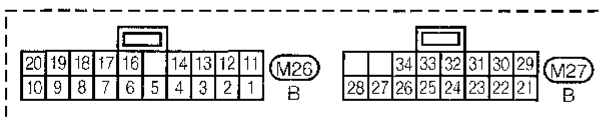
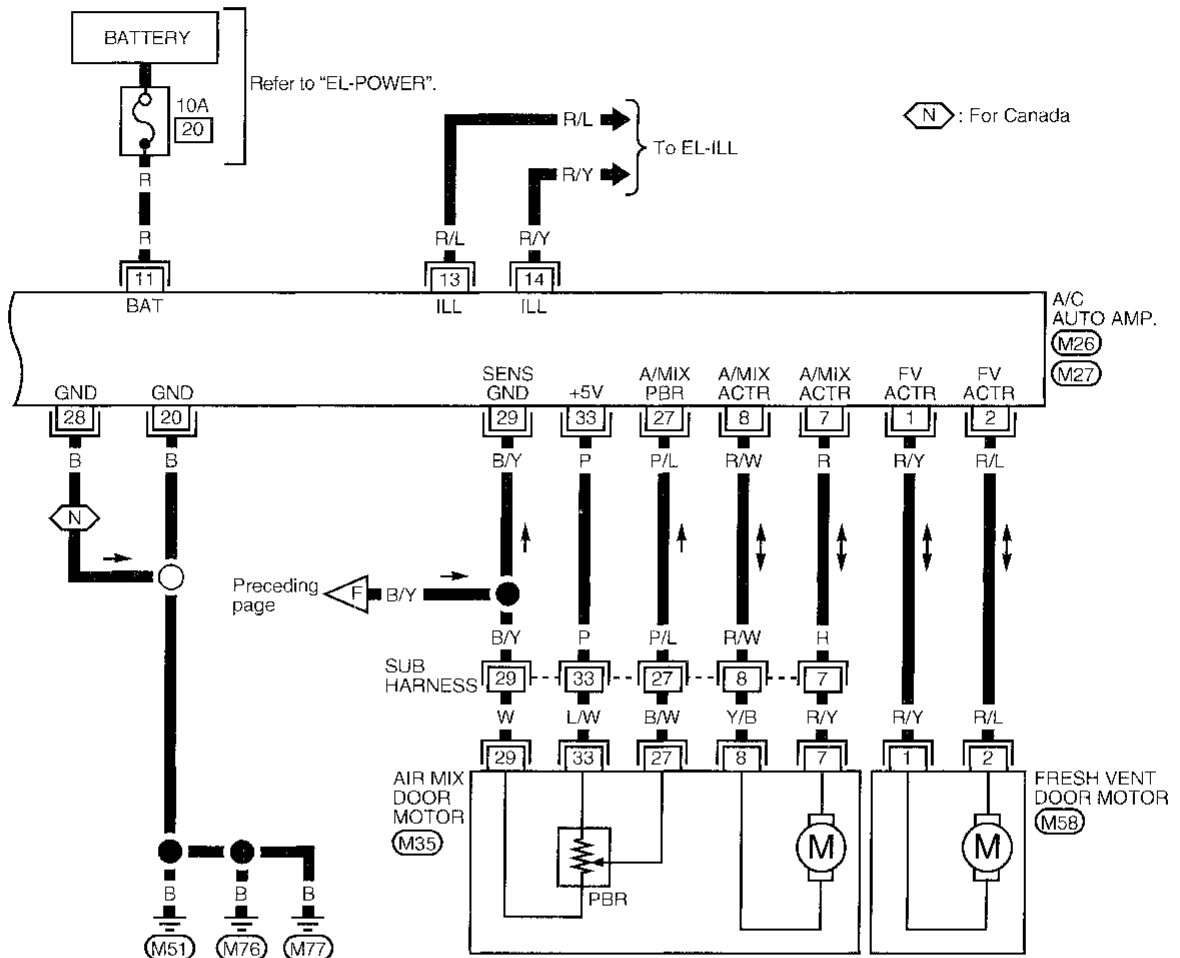

Wiring Diagram -A/C, A- (Cont'd)

HA-A/C,A-06

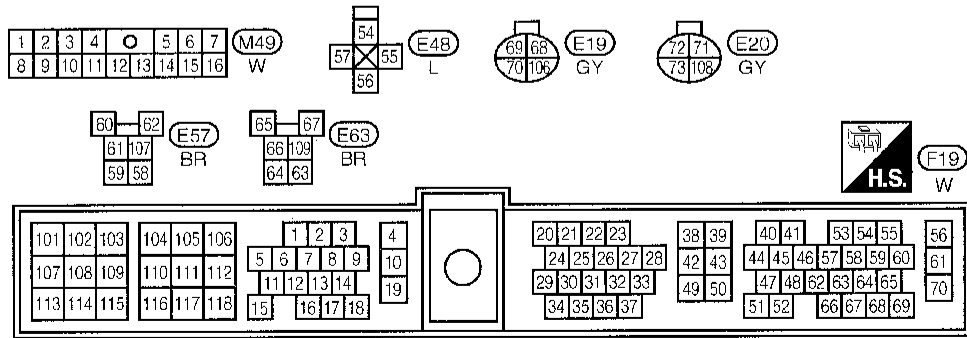
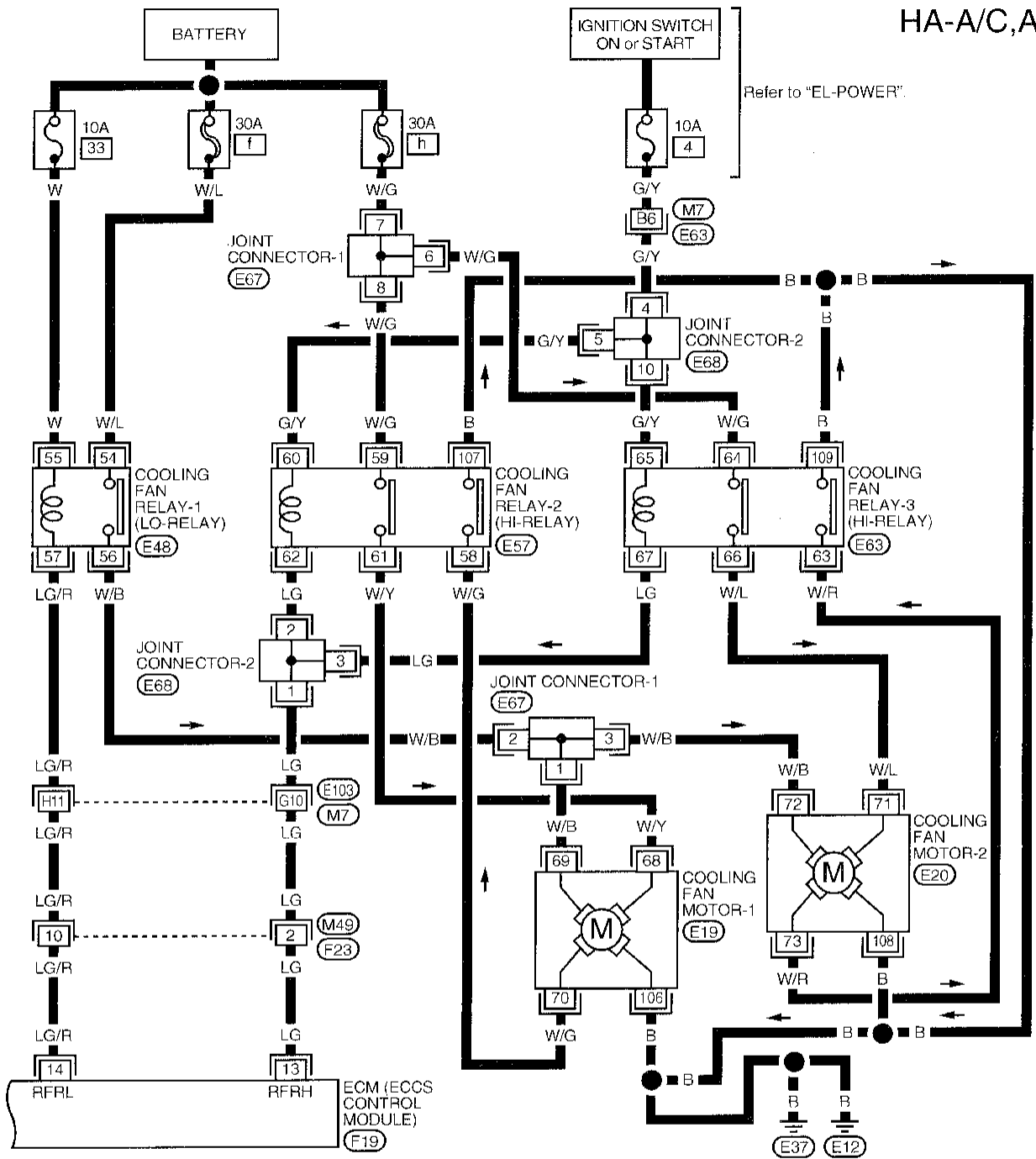

Refer to last page (Foldout page).

- M7
- E103
- E67
- E68

GI
MA
FM
LG
FC
FF
CL
MT
AT
FA
RA
BR
ST
RS
BT

HA

EL

DX

Main Power Supply and Ground Circuit Check

POWER SUPPLY CIRCUIT CHECK FOR AUTO A/C SYSTEM

Check power supply circuit for auto air conditioner system.

Refer to EL section (“Wiring Diagram”, “POWER SUPPLY ROUTING”) and HA-96.

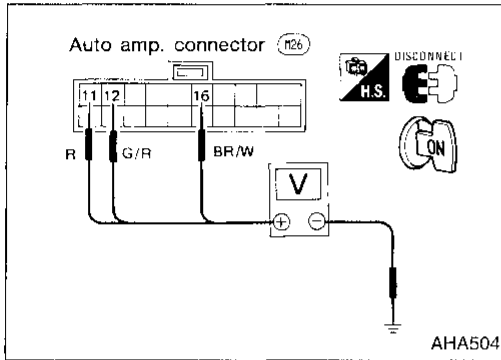

AUTO AMP. CHECK

Check power supply circuit for auto amp. with ignition switch ON.

1. Disconnect auto amp. harness connector.
2. Connect voltmeter from harness side.
3. Measure voltage across terminal No. ①①, ①②, ①⑥ and body ground.

Voltmeter terminal		Voltage
⊕	⊖	
①①	Body ground	Approx. 12V
①②		
①⑥		

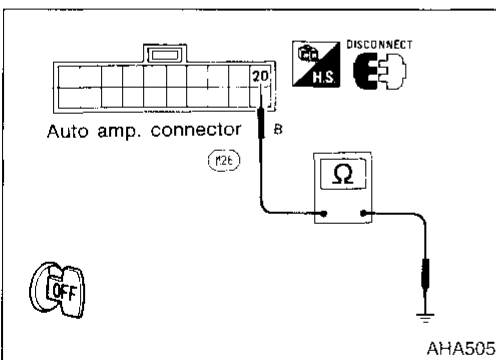

Check body ground circuit for auto amp. with ignition switch OFF.

1. Disconnect auto amp. harness connector.
2. Connect ohmmeter from harness side.
3. Check for continuity between terminal No. ②①, ②⑧ and body ground.

Ohmmeter terminal		Continuity
⊕	⊖	
②①	Body ground	Yes
②⑧ (Canada only)		

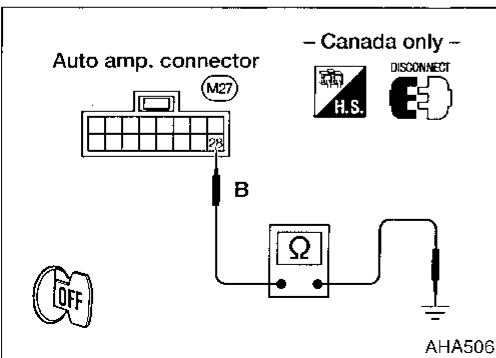

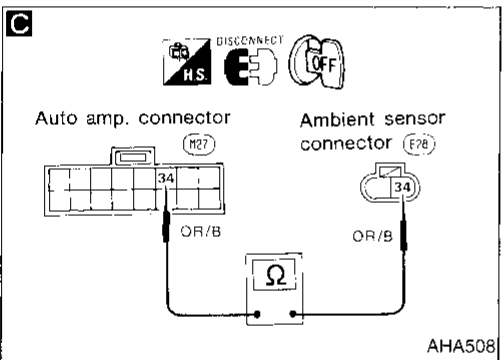
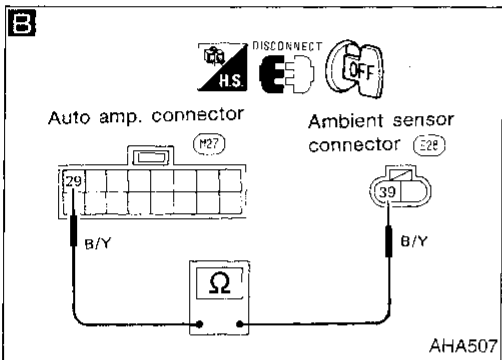
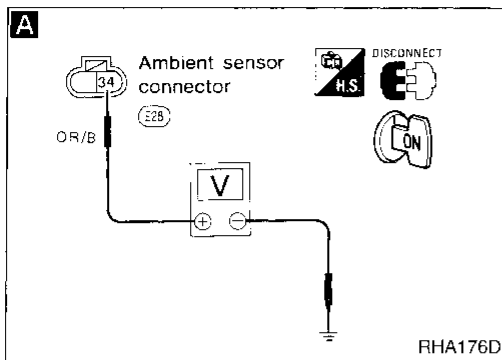

Diagnostic Procedure 1

SYMPTOM: Ambient sensor circuit is open or shorted. (21 or ^{ECON}21 is indicated on auto amp. as a result of conducting Self-diagnosis STEP 2.)

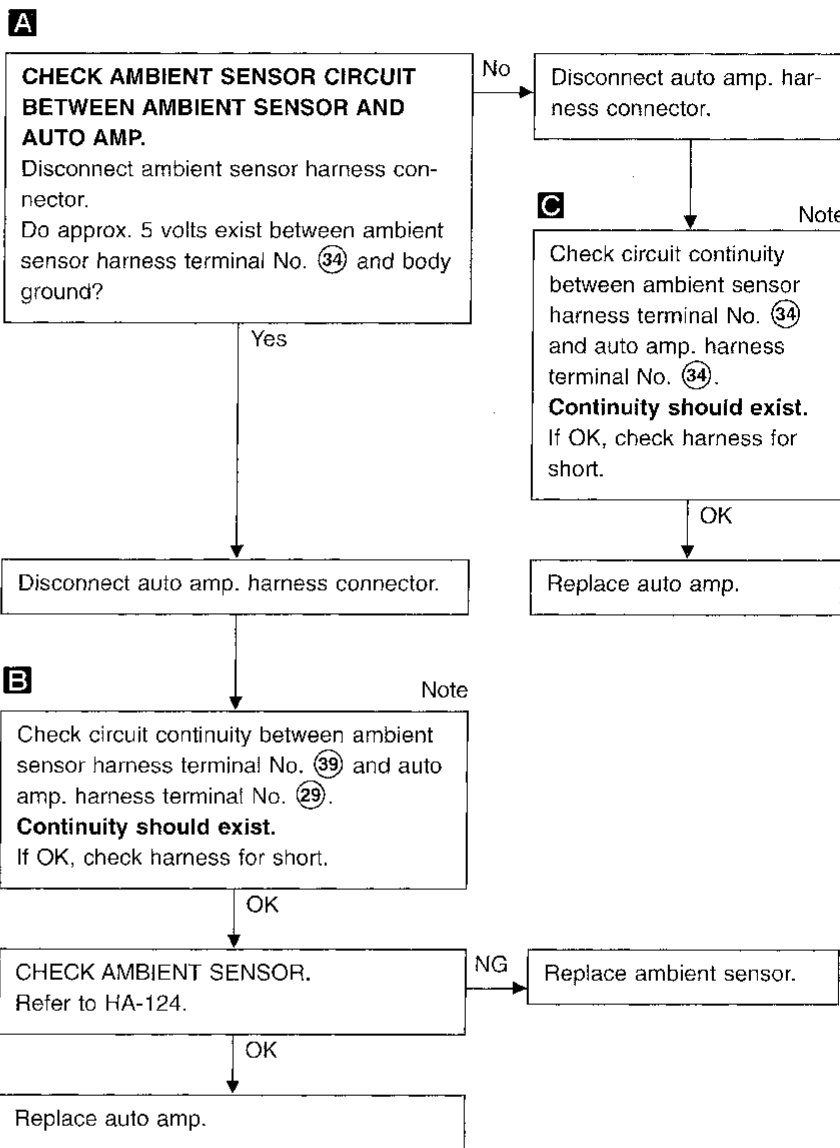

Note:
If the result is NG or No after checking circuit continuity, repair harness or connector.

GI
MA
EM
IC
EC
FE
CL
MT
AT
FA
RA
BR
ST
RS
BT
HA
ET
IDX

Diagnostic Procedure 2

SYMPTOM: In-vehicle sensor circuit is open or shorted.
(22 or ECON₂₂ is indicated on auto amp. as a result of conducting Self-diagnosis STEP 2.)

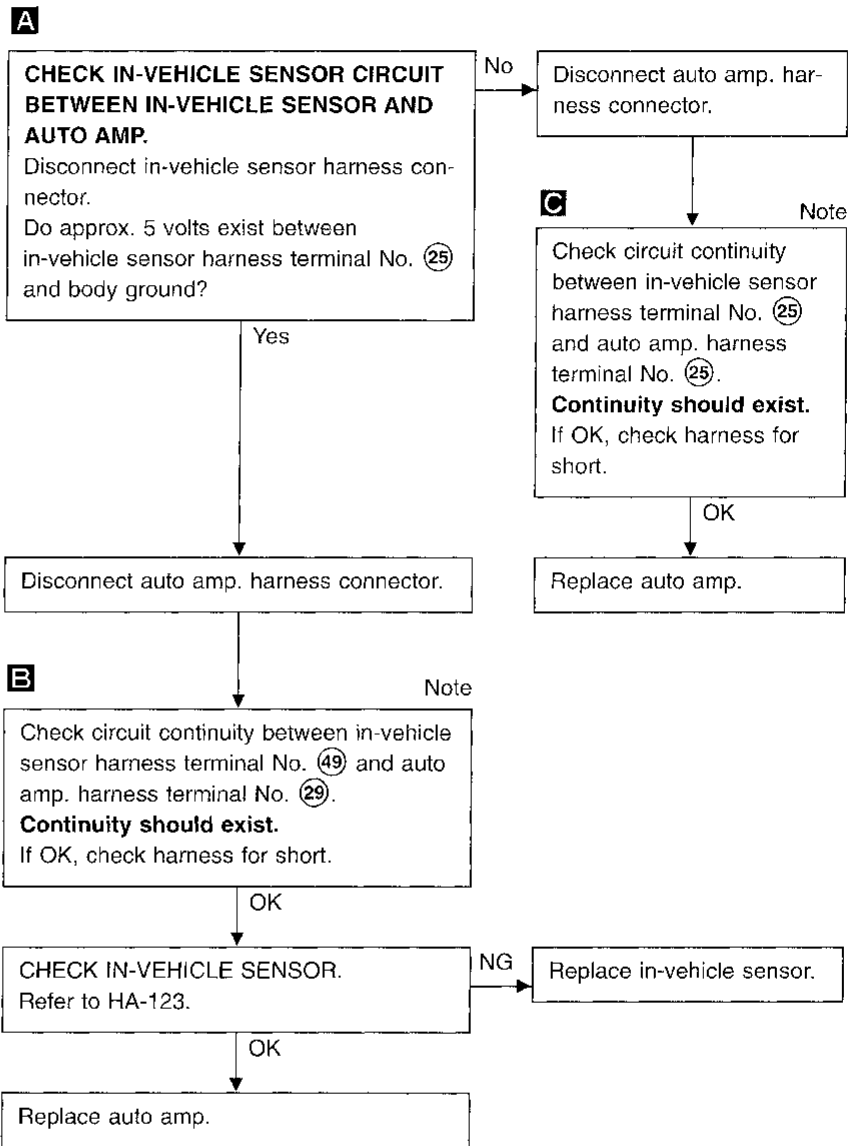
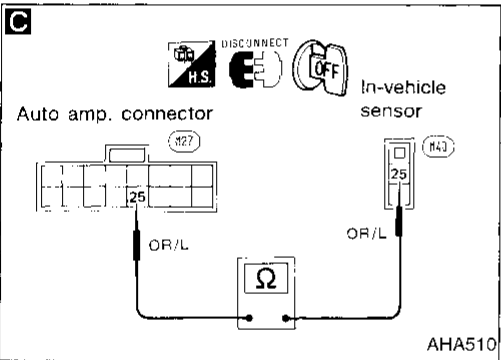
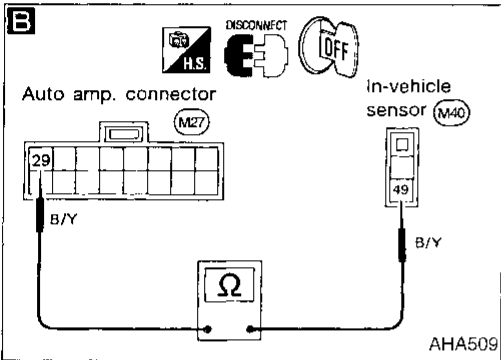
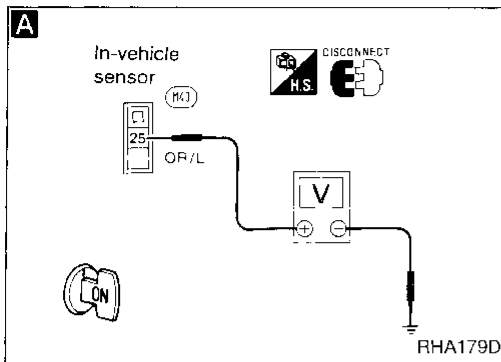

Note:
If the result is NG or No after checking circuit continuity, repair harness or connector.

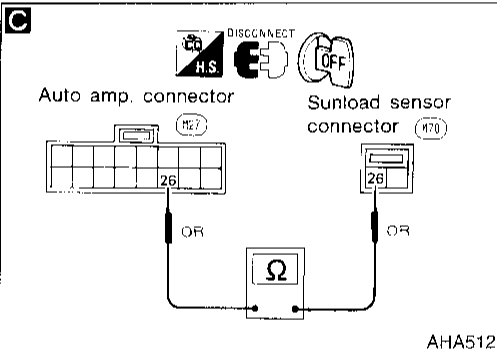
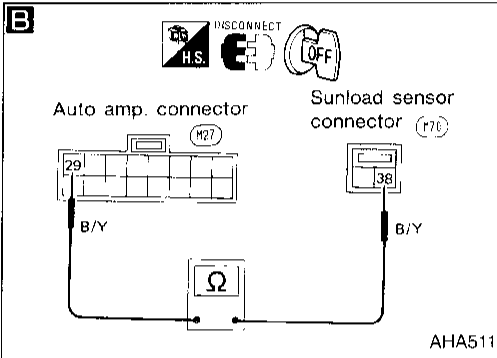
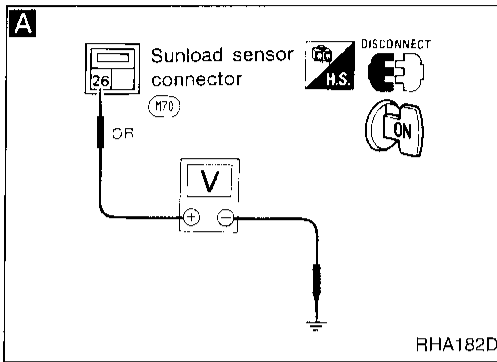

Diagnostic Procedure 3

SYMPTOM: Sunload sensor circuit is open or shorted.
 (25 or ^{ECON}25 is indicated on auto amp. as a result of conducting Self-diagnosis STEP 2.)

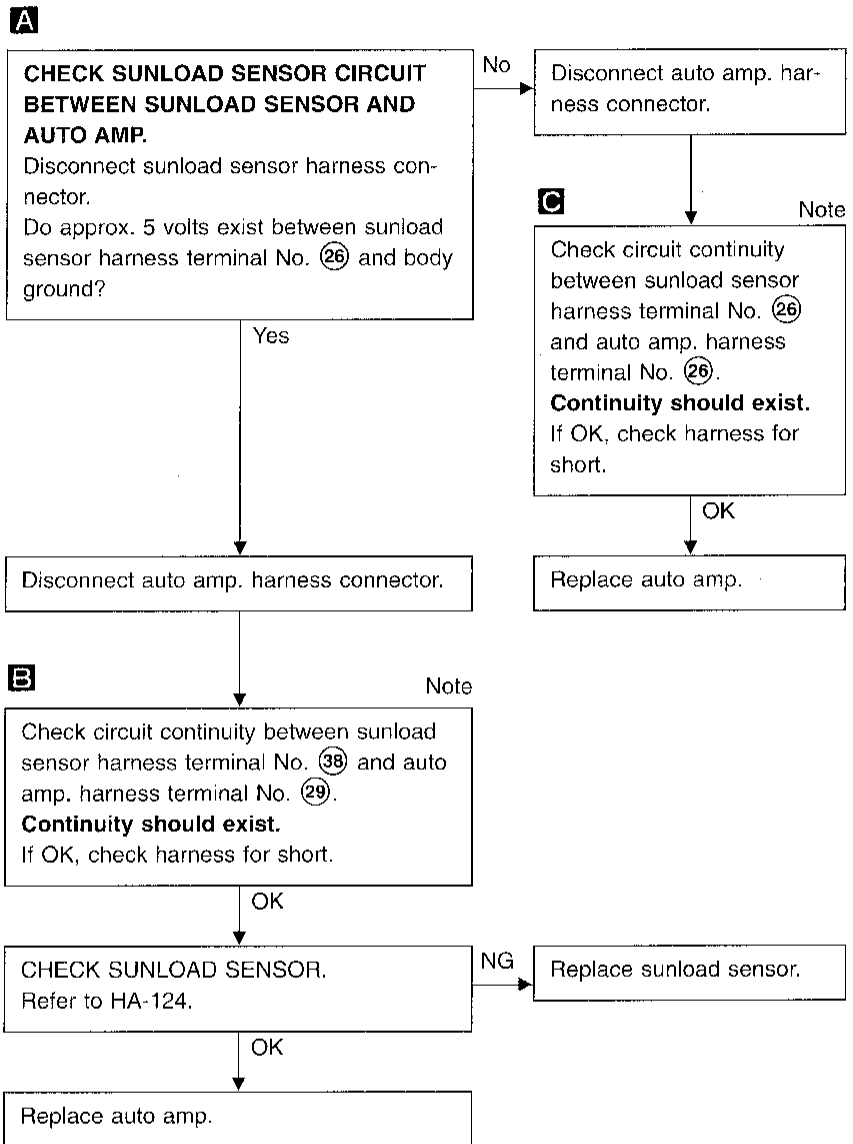

Note:
 If the result is NG or No after checking circuit continuity, repair harness or connector.

CI
 MA
 EM
 LC
 EC
 FC
 CL
 MT
 AT
 FA
 HA
 BR
 ST
 HS
 BT
 HA
 FI
 DX

Diagnostic Procedure 4

SYMPTOM: PBR circuit is open or shorted. (25 or ECON₂₅ is indicated on auto amp. as a result of conducting Self-diagnosis STEP 2.)

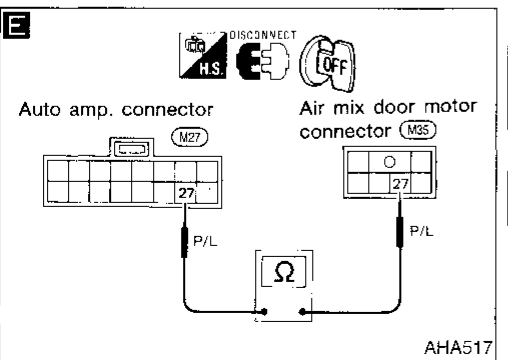
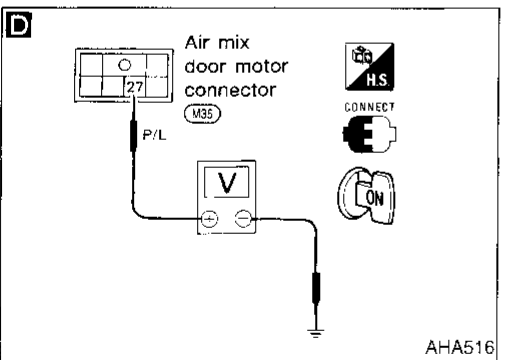
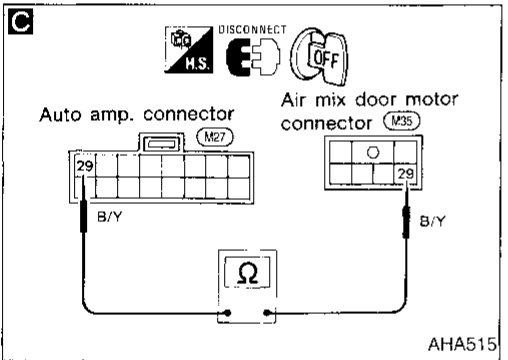
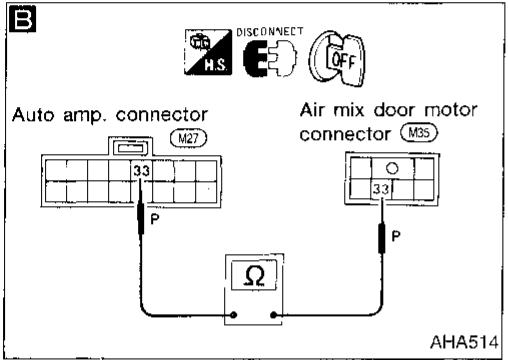
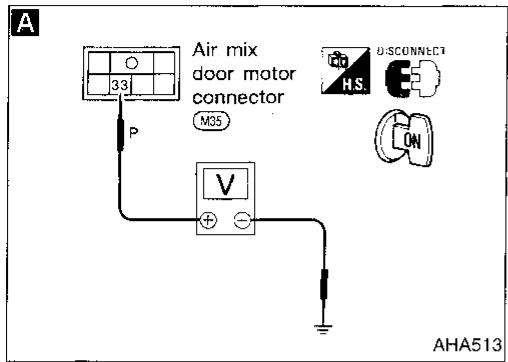

A

CHECK PBR CIRCUIT BETWEEN PBR AND AUTO AMP.

Disconnect air mix door motor harness connector.

Do approx. 5 volts exist between air mix door motor harness terminal No. (33) and body ground?

No → Disconnect auto amp. harness connector.

B Note

Check circuit continuity between air mix door motor harness terminal No. (33) and auto amp. harness terminal No. (33).

Continuity should exist.

If OK, check harness for short.

OK → Replace auto amp.

C Note

Check circuit continuity between air mix door motor harness terminal No. (29) and auto amp. harness terminal No. (29).

Continuity should exist.

If OK, check harness for short.

OK →

D

CHECK PBR CIRCUIT BETWEEN PBR AND AUTO AMP.

1. Reconnect auto amp. harness connector and air mix door harness connector.
2. Set temperature switch to full hot. Do approx. 5 volts exist between air mix door motor harness terminal (27) and body ground?
3. Set temperature switch to full cold. Do approx. 0 volts exist between air mix door motor harness terminal (27) and body ground?

No → Disconnect auto amp. harness connector.

E Note

Check circuit continuity between air mix door motor harness terminal No. (27) and auto amp. harness terminal No. (27).

Continuity should exist.

If OK, check harness for short.

OK → Replace auto amp.

CHECK PBR.

Refer to HA-127.

OK → Replace auto amp.

NG → Replace air mix door motor (PBR).

Note:
If the result is NG or No after checking circuit continuity, repair harness or connector.

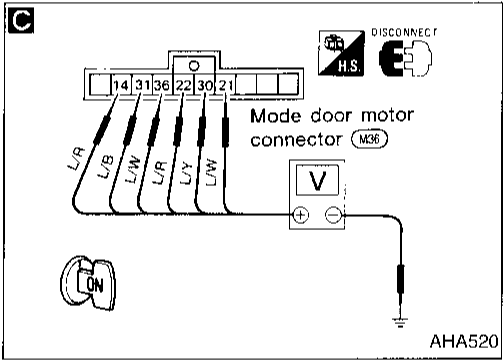
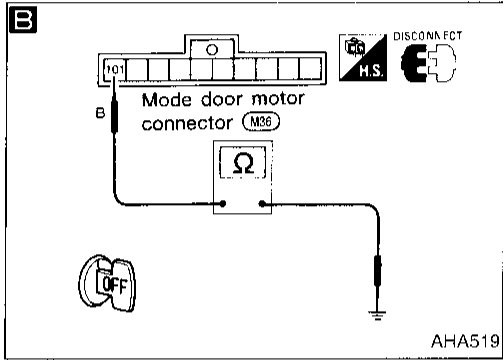
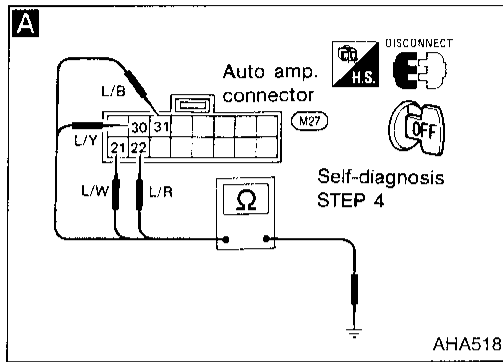

Diagnostic Procedure 5

SYMPTOM: Mode door motor does not operate normally.

- Perform Self-diagnosis STEPS 1 to 4 before referring to the following flow chart.

A

CHECK MODE DOOR MOTOR POSITION SWITCH.

1. Set up code No. 41 in Self-diagnosis STEP 4.
2. Disconnect auto amp. harness connector after turning ignition switch OFF.
3. Check if continuity exists between terminal No. (21) or (30) of auto amp. harness connector and body ground.
4. Using above procedure, check for continuity in any other mode, as indicated in chart.

Code No.	Condition	Terminal No.		Continuity
		⊕	⊖	
41	FACE	(21) or (30)	Body ground	Yes
42 or 43	B/L	(22) or (30)		
44	FOOT	(21) or (22)		
45	F/D	(21) or (31)		
46	DEF	(22) or (31)		

OK

INSPECTION END

NG

Disconnect mode door motor harness connector.

B Note

CHECK BODY GROUND CIRCUIT FOR MODE DOOR MOTOR.
Does continuity exist between mode door motor harness terminal No. (101) and body ground?

Yes

Reconnect auto amp. harness connector.

C

CHECK POWER SUPPLY FOR MODE DOOR MOTOR CONTROL CIRCUIT.
Do approx. 5 volts exist between mode door motor harness terminals and body ground?

Terminal No.		Voltage
⊕	⊖	
(21)	Body ground	Approx. 5V
(30)		
(22)		
(36)		
(31)		
(14)		

Yes

Reconnect mode door motor harness connector.

No

A **B**

(Go to next page.)

Note:
If the result is NG or No after checking circuit continuity, repair harness or connector.

Diagnostic Procedure 5 (Cont'd)

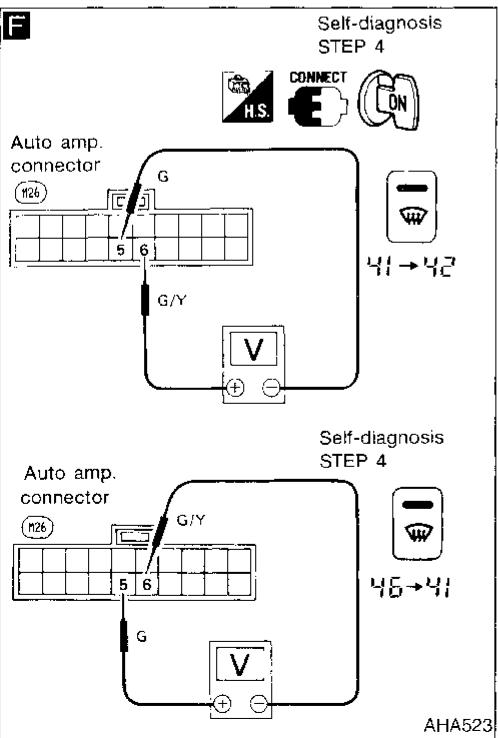
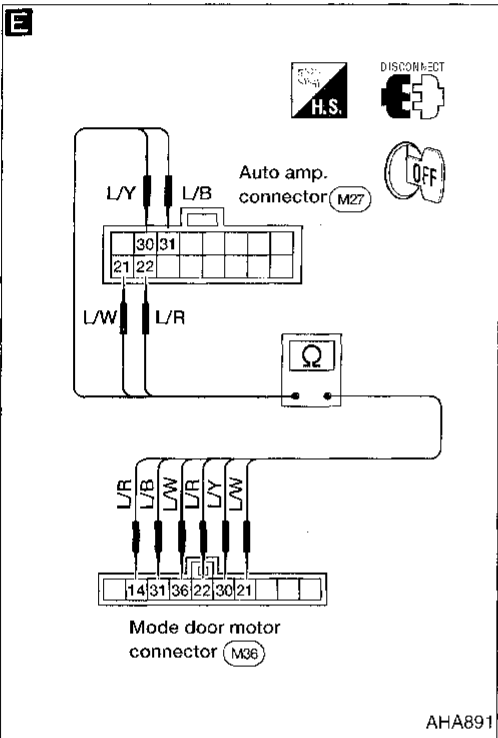
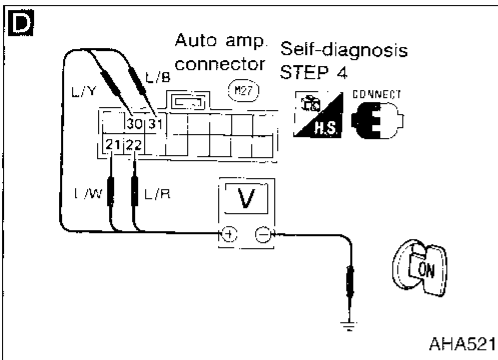

D

CHECK MODE DOOR MOTOR POSITION SWITCH.
Set up Self-diagnosis STEP 4. Measure voltage across auto amp. harness terminals and body ground.

Code No.	Condition	Terminal No.				Body ground	
		⊕					⊖
		(22)	(31)	(21)	(30)		
41	FACE	5V	5V	0V	0V	Body ground	
42 or 43	B/L	0V	5V	5V	0V		
44	FOOT	0V	5V	0V	5V		
45	D/F	5V	0V	0V	5V		
46	DEF	0V	0V	5V	5V		
		0V: Approx. 0V					5V: Approx. 5V

OK → Replace mode door motor.

NG → Replace auto amp.

E

Note

Check circuit continuity between each terminal on auto amp. and on mode door motor.

Terminal No.		Continuity
⊕	⊖	
Auto amp. (30)	Mode door motor (30)	Yes
(22)	(14 or 22)	
(21)	(21 or 36)	
(31)	(31)	

If OK, check harness for short.

OK → Replace auto amp.

F

CHECK FOR AUTO AMP. OUTPUT.
Do approx. 10.5 volts exist between auto amp. harness terminals No. (5) and (6) when code No. is switched from 41 to 42 or when code No. is switched from 46 to 41?

Code No.	Mode door motor operation	Terminal No.		Voltage V
		(6)	(5)	
41 → 42	FACE → B/L	⊕	⊖	Approx. 10.5
46 → 41	DEF → FACE	⊖	⊕	
—	Stop	⊖	⊖	0

Yes → Replace mode door motor.

No → Replace auto amp.

Note:
If the result is NG or No after checking circuit continuity, repair harness or connector.

Diagnostic Procedure 6

SYMPTOM: Intake door motor does not operate normally.

- Perform Self-diagnosis STEPS 1, 2 and 4 before referring to the flow chart.

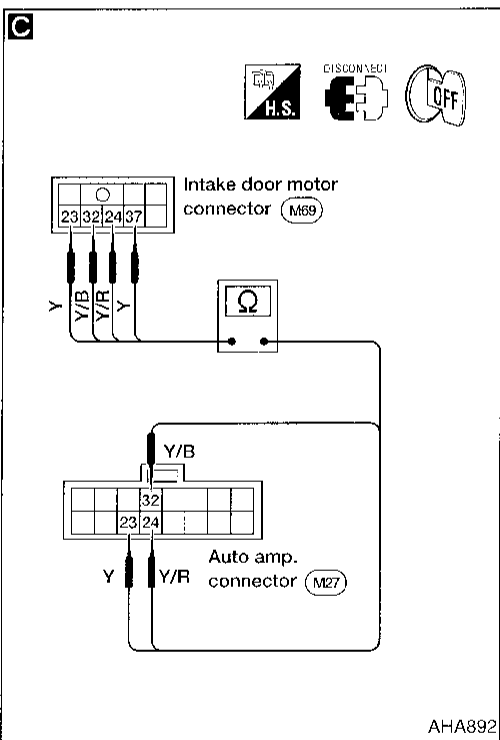
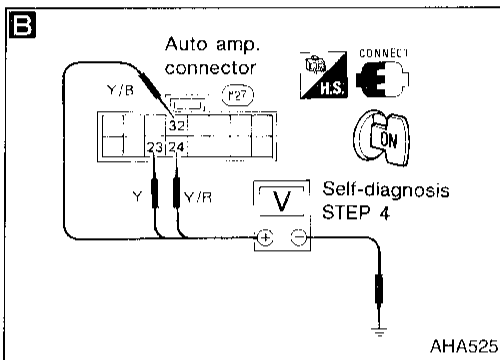
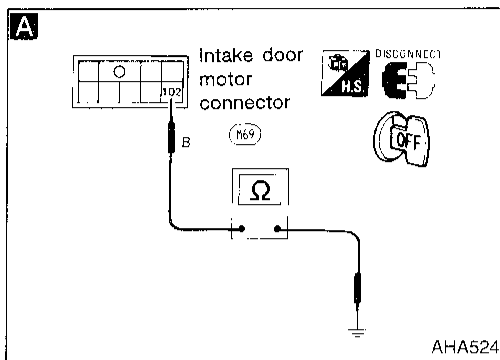

A Note

CHECK BODY GROUND CIRCUIT FOR INTAKE DOOR MOTOR.
 Disconnect intake door motor harness connector.
 Does continuity exist between intake door motor harness terminal No. (102) and body ground?

Yes

B Note

CHECK FOR AUTO AMP. OUTPUT.
 Set up Self-diagnosis STEP 4.
 Measure voltage across auto amp. harness terminals and body ground.

Code No.	Terminal No.		Condition	Voltage V
	⊕	⊖		
41 42	(23)	Body ground	REC	0
	(24)			0
	(32)			12
43	(23)	Body ground	20% REC	12
	(24)			0
	(32)			0
44 45 46	(23)	Body ground	FRE	0
	(24)			12
	(32)			0

0V: Approx. 0V
 12V: Approx. 12V

OK

Replace intake door motor.

Note:
 If the result is NG or No after checking circuit continuity, repair harness or connector.

C Note

Check circuit continuity between each terminal on auto amp. and on intake door motor.

Terminal No.		Continuity
⊕	⊖	
Auto amp. (23)	Intake door motor (23 or 37)	Yes
(24)	(24)	
(32)	(32)	

If OK, check harness for short.

OK

Replace auto amp.

GI
 MA
 EM
 LC
 EC
 FE
 CL
 WT
 AT
 FA
 HA
 BR
 ST
 HS
 ET
 HA
 FL
 DX

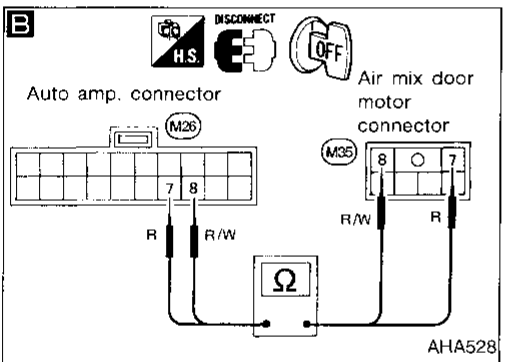
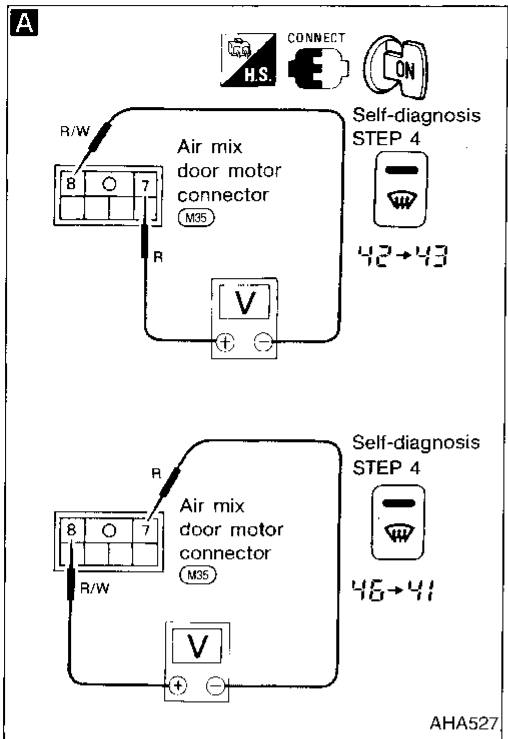

Diagnostic Procedure 7

SYMPTOM: Air mix door motor does not operate normally.

- Perform Self-diagnosis STEPS 1, 2 and 4 before referring to the following flow chart.

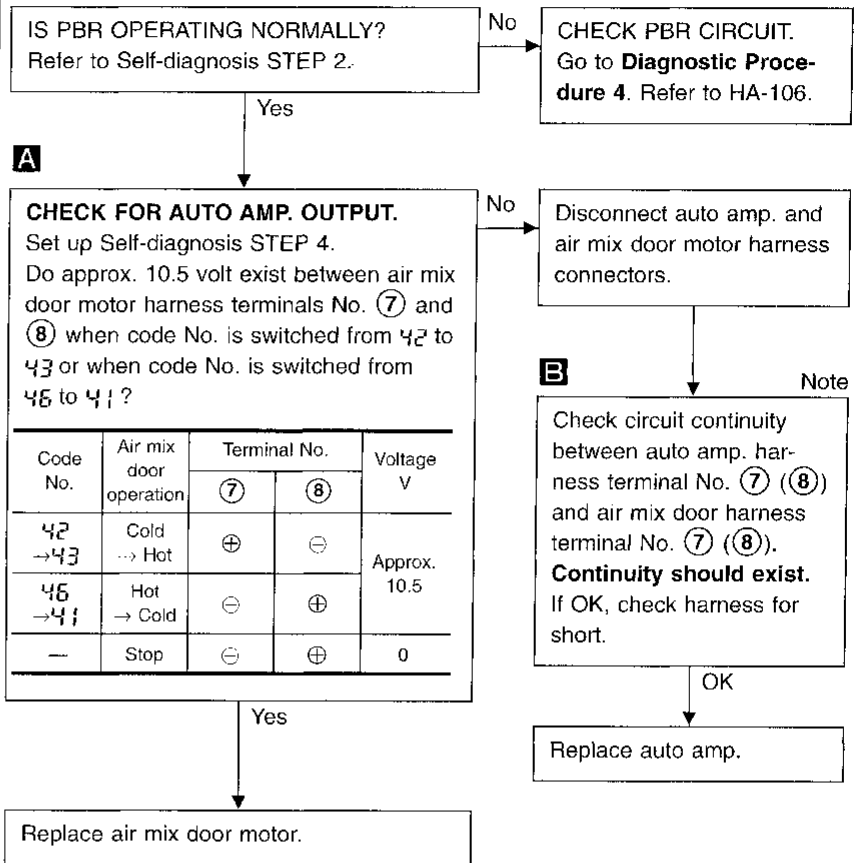

Note:
If the result is NG or No after checking circuit continuity, repair harness or connector.

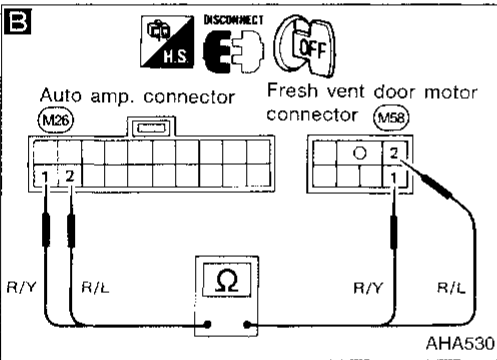
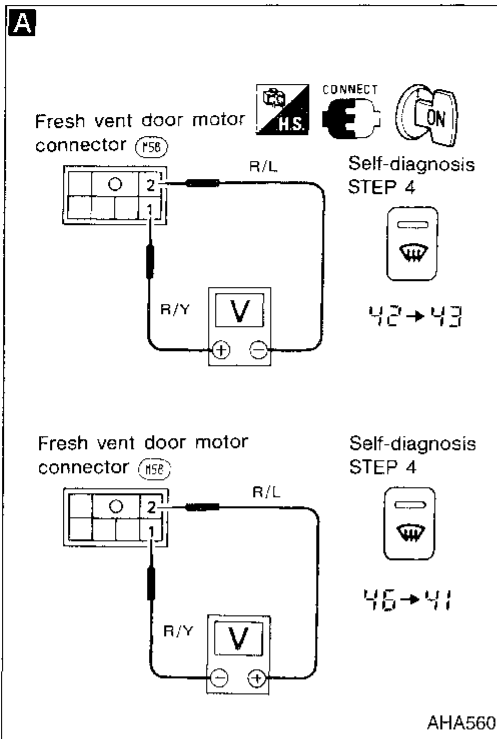

Diagnostic Procedure 8

SYMPTOM: Fresh vent door motor does not operate normally.

- Perform Self-diagnosis STEP 4 before referring to the following flow chart.

A

CHECK FOR AUTO AMP. OUTPUT.
 Set up Self-diagnosis STEP 4.
 Do approx. 12 volts exist between fresh vent door motor harness terminals ① and ② when code No. is switched from 42 to 43 or when code No. is switched from 46 to 41?

Code No.	Fresh vent door condition	Terminal No.		Voltage V
		①	②	
42 → 43	OPEN → CLOSE	⊕	⊖	Approx. 12V
46 → 41	CLOSE → OPEN	⊖	⊕	

Yes → Replace fresh vent door motor.

No → Disconnect auto amp. harness connector.

B Note

Check circuit continuity between auto amp. harness terminal ① (②) and fresh vent door motor harness terminal No. ① (②).
Continuity should exist.
 If OK, check harness for short.

OK → Replace auto amp.

Note:
 If the result is NG or No after checking circuit continuity, repair harness or connector.

GI
 MA
 EM
 LC
 EC
 FE
 CL
 MT
 AT
 FA
 RA
 BR
 ST
 RS
 BT
 HA
 EL
 IDX

Diagnostic Procedure 9

SYMPTOM: Blower motor operation is malfunctioning under Starting Fan Speed Control.

- Perform Preliminary Check 5 before referring to the following flow chart.

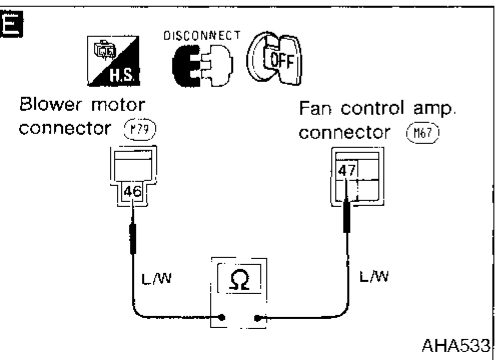
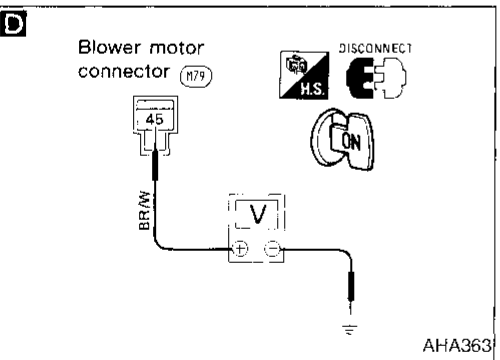
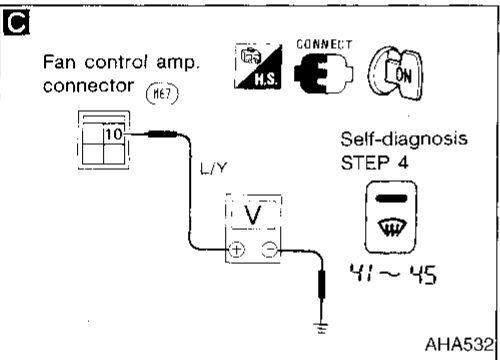
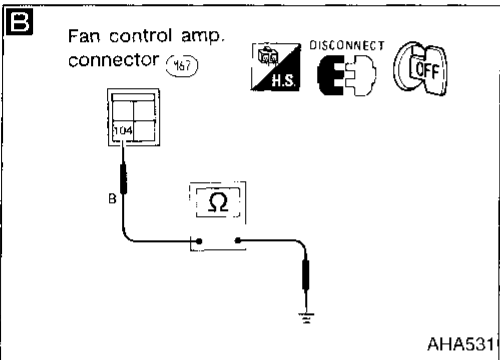
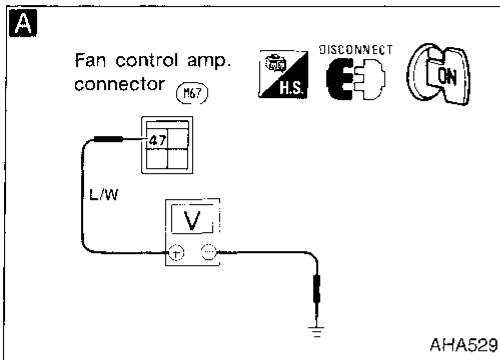

A
CHECK POWER SUPPLY FOR FAN CONTROL AMP.
 Disconnect fan control amp. harness connector.
 Do approx. 12 volts exist between fan control amp. harness terminal No. (47) and body ground?

B Note
CHECK BODY GROUND CIRCUIT FOR FAN CONTROL AMP.
 Does continuity exist between fan control amp. harness terminal No. (104) and body ground?

Reconnect fan control amp. harness connector.

C
CHECK FOR AUTO AMP. OUTPUT.
 Set up Self-diagnosis STEP 4.
 Measure voltage across fan control amp. harness terminal No. (10) and body ground.

Code No.	Terminal No.		Voltage
	⊕	⊖	
41-45	(10)	Body ground	Approx. 1 - 3V

Replace fan control amp.

D
CHECK POWER SUPPLY FOR BLOWER MOTOR.
 Disconnect blower motor harness connector.
 Do approx. 12 volts exist between blower motor harness terminal No. (45) and body ground?

Check 20A fuses at fuse block. Refer to EL section ("Wiring Diagram", "POWER SUPPLY ROUTING") and HA-96.

E Note
 Check circuit continuity between blower motor harness terminal No. (46) and fan control amp. harness terminal No. (47).
Continuity should exist. If OK, check harness for short.

CHECK BLOWER MOTOR.
 Refer to HA-119.

Replace blower motor.

Note:
 If the result is NG or No after checking circuit continuity, repair harness or connector.

Diagnostic Procedure 9 (Cont'd)

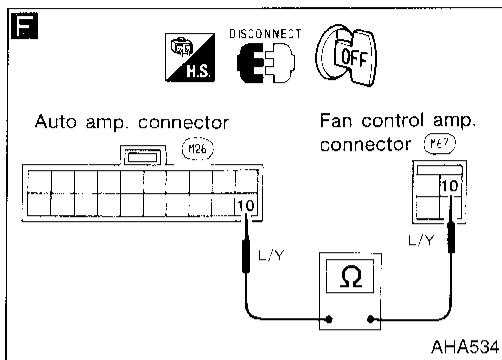

A
Disconnect auto amp. and fan control amp. harness connector.

F Note
Check harness continuity between auto amp. harness terminal No. ⑩ and fan control amp. harness terminal No. ⑩.
Continuity should exist.
If OK, check harness for short.

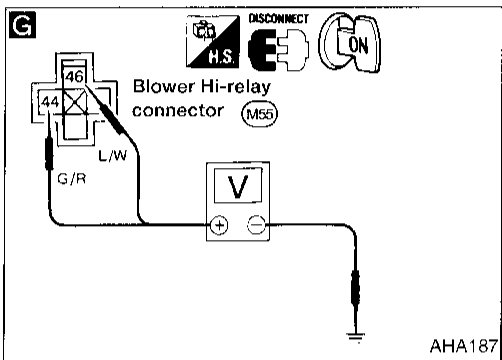

G
CHECK POWER SUPPLY FOR BLOWER HI-RELAY.
Do approx. 12 volts exist between blower Hi-relay harness terminals No. ④④, ④⑥ and body ground?

No → Check 10A or 20A fuses at fuse block. Refer to EL section ("Wiring Diagram", "POWER SUPPLY ROUTING") and HA-96.

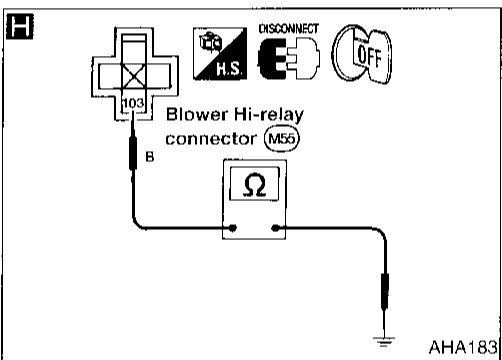

H Note
CHECK BODY GROUND CIRCUIT FOR BLOWER HI-RELAY.
Does continuity exist between blower Hi-relay harness terminal No. ⑩③ and body ground?

Yes → **CHECK BLOWER HI-RELAY AFTER DISCONNECTING IT.**
Refer to HA-119.

NG → Replace blower Hi-relay.

OK → Reconnect blower Hi-relay.

B
(Go to next page.)

Note:
If the result is NG or No after checking circuit continuity, repair harness or connector.

GI
MA
EM
LC
EC
FE
CL
MT
AT
FA
RA
BR
GT
RS
BT
HA
EL
DX

Diagnostic Procedure 9 (Cont'd)

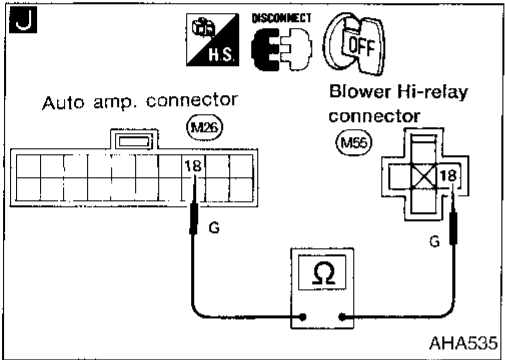
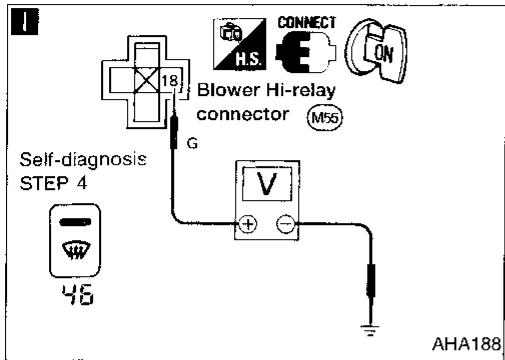

(B)

I

CHECK FOR AUTO AMP. OUTPUT.
Set up Self-diagnosis STEP 4.
Measure voltage across blower Hi-relay harness terminal No. (18) and body ground.

Code No.	Terminal No.		Voltage
	⊕	⊖	
45	(18)	Body ground	Less than approx. 1.5V

NG → Disconnect blower Hi-relay and auto amp. harness connectors.

J Note

Does continuity exist between blower Hi-relay harness terminal No. (18) and auto amp. harness terminal No. (18)?
Continuity should exist.
If OK, check harness for short.

Yes → Replace auto amp.

OK → Replace blower motor.

Note:
If the result is NG or No after checking circuit continuity, repair harness or connector.

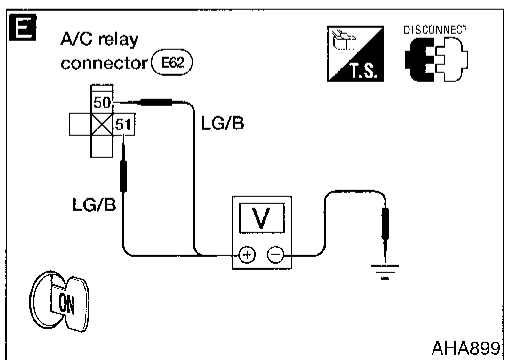
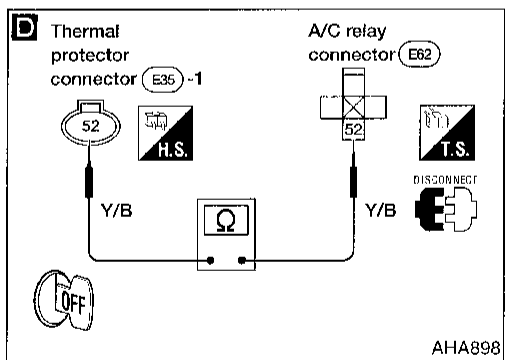
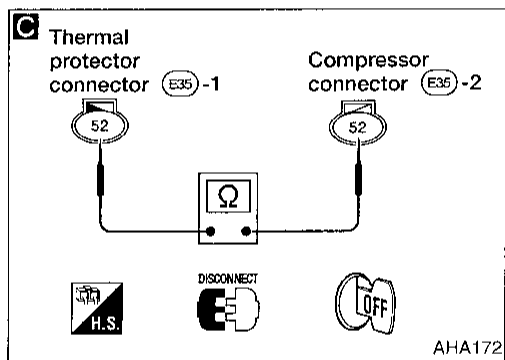
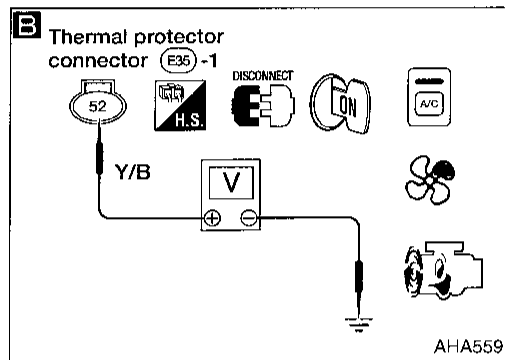
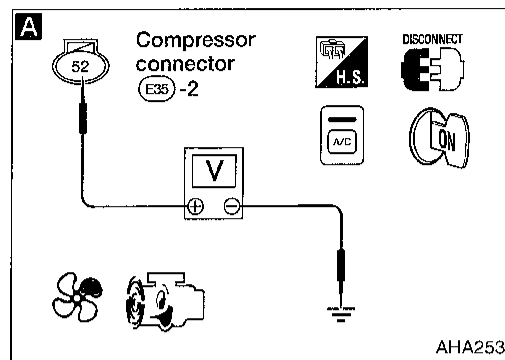

Diagnostic Procedure 10

SYMPTOM: Magnet clutch does not engage after performing Preliminary Check 6.

- Perform Preliminary Check 6 before referring to the flow chart.

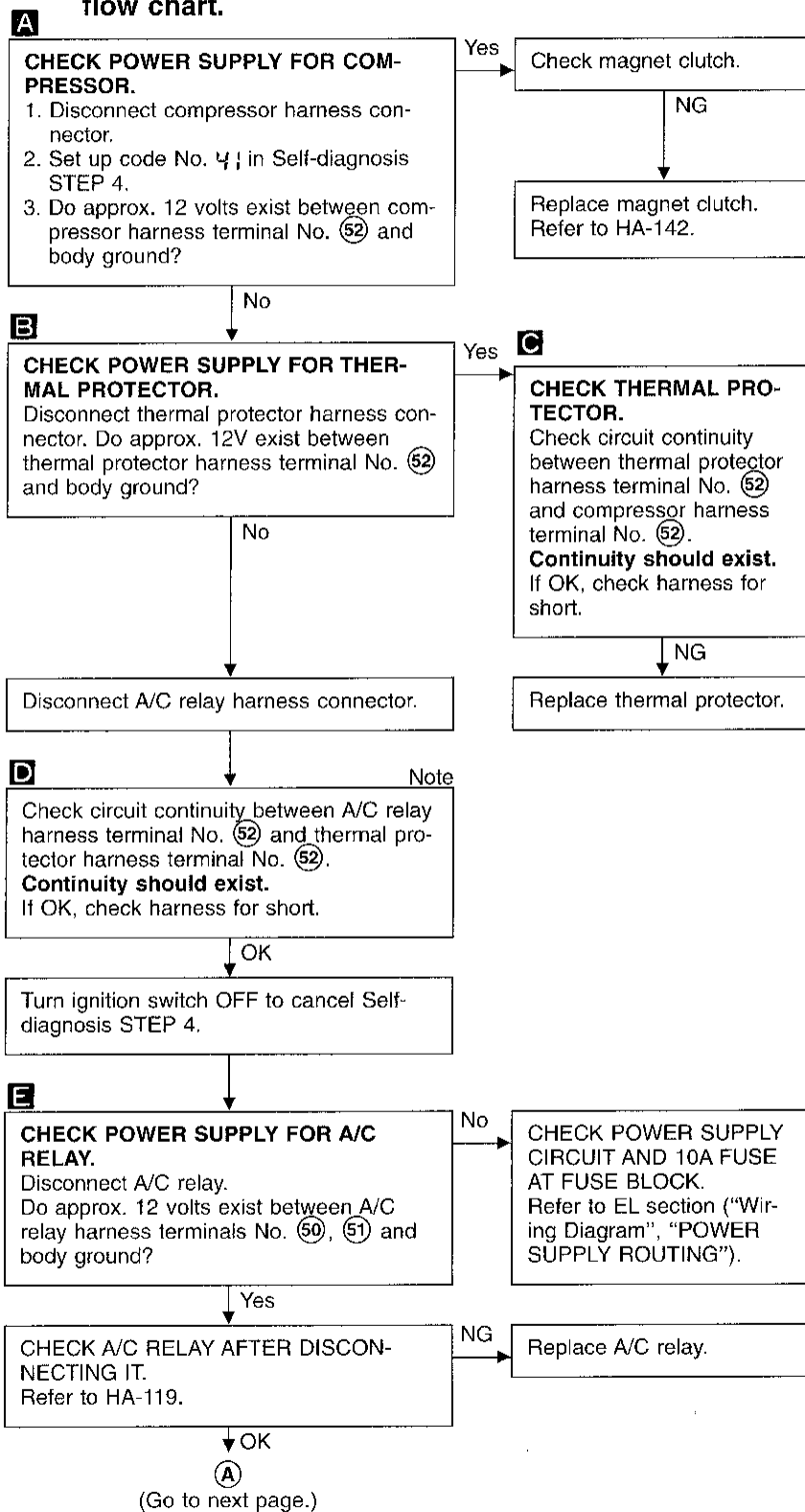

Note:
If the result is NG or No after checking circuit continuity, repair harness or connector.

(Go to next page.)

Diagnostic Procedure 10 (Cont'd)

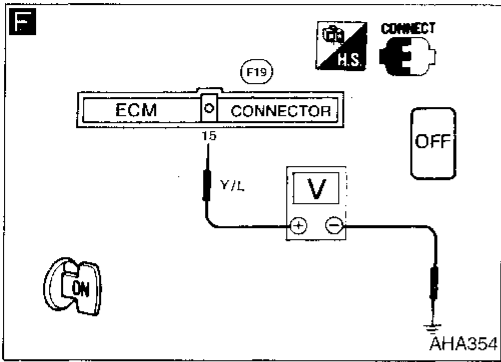

(A)
Reconnect A/C relay.
Turn ignition switch ON and press OFF switch.

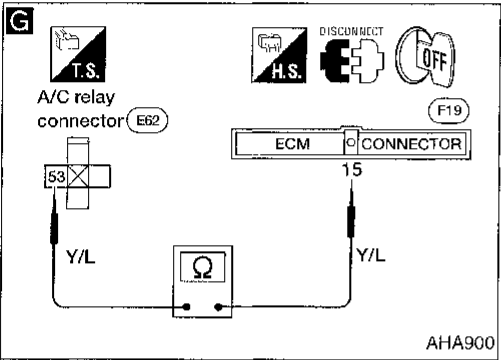

F
CHECK COIL SIDE CIRCUIT OF A/C RELAY.
Do approx. 12 volts exist between ECM (ECCS control module) harness terminal No. (15) and body ground?
(For terminal arrangement, refer to HA-96.)

G Note
Check circuit continuity between A/C relay harness terminal No. (53) and ECM (ECCS control module) harness terminal No. (15).
(For terminal arrangement, refer to HA-96.)
Continuity should exist.
If OK, check harness for short.

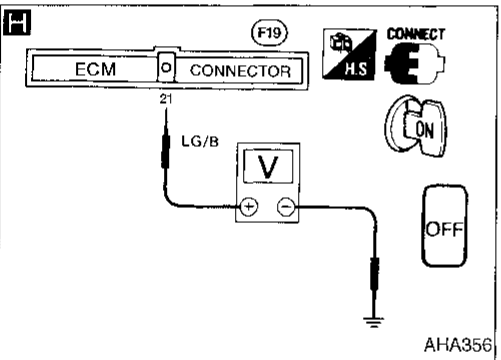

H
CHECK COIL SIDE CIRCUIT OF A/C RELAY CONTROLLED BY ECM (ECCS control module).
Do more than 8 volts exist between ECM (ECCS control module) harness terminal No. (21) and body ground?
(For terminal arrangement, refer to HA-96.)

No
CHECK ECM (ECCS control module).
Refer to EC section ("TROUBLE DIAGNOSIS FOR DTC 31").

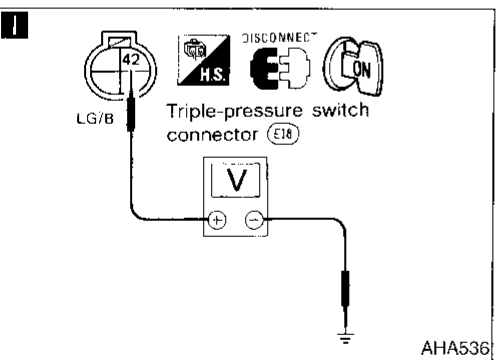

I
CHECK TRIPLE-PRESSURE SWITCH CIRCUIT BETWEEN TRIPLE-PRESSURE SWITCH AND ECM (ECCS control module).
Disconnect triple-pressure switch harness connector.
Do more than 8 volts exist between triple-pressure switch harness terminal No. (42) and body ground?

No
Disconnect ECM (ECCS control module) harness connector.

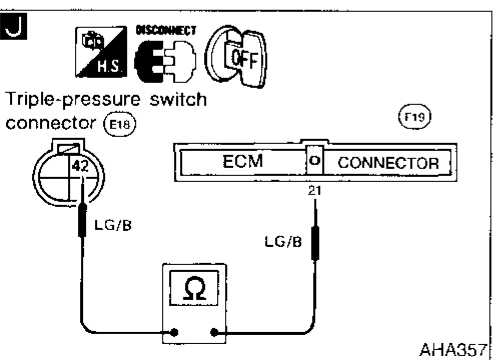

J Note
Check circuit continuity between ECM (ECCS control module) harness terminal No. (21) and triple-pressure switch harness terminal No. (42).
(For terminal arrangement, refer to HA-96.)
Continuity should exist.
If OK, check harness for short.

CHECK TRIPLE-PRESSURE SWITCH.
Refer to HA-119.

NG
Replace triple-pressure switch.

OK
(Go to next page.)

Note:
If the result is NG or No after checking circuit continuity, repair harness or connector.

Diagnostic Procedure 10 (Cont'd)

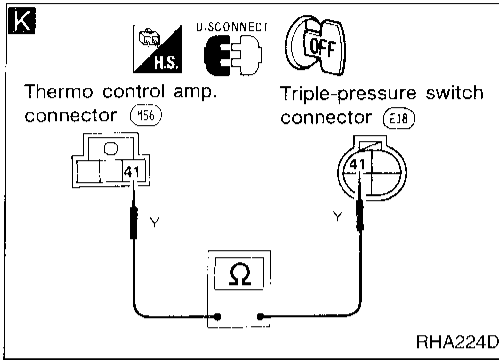

RHA224D

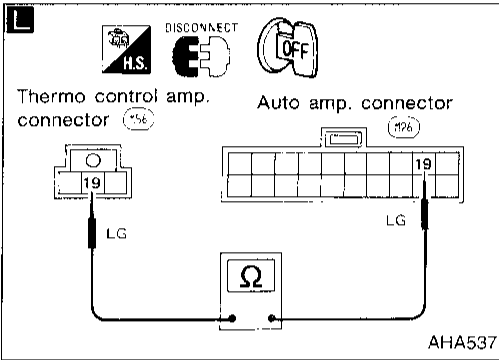

AHA537

```

    graph TD
        B((B)) --> B1[Disconnect thermo control amp. harness connector.]
        B1 --> K1[Check circuit continuity between thermo control amp. harness terminal No. 41 and triple-pressure switch harness terminal No. 41. Continuity should exist. If OK, check harness for short.]
        K1 -- NG --> K2[CHECK THERMO CONTROL AMP. Refer to HA-119.]
        K1 -- OK --> B2[Disconnect auto amp. harness connector.]
        K2 -- NG --> B3[Replace thermo control amp.]
        B2 --> L1[Check circuit continuity between auto amp. harness terminal No. 19 and thermo control amp. harness terminal No. 19. Continuity should exist. If OK, check harness for short.]
        L1 -- OK --> B4[Replace auto amp.]
    
```

Note:
If the result is NG or No after checking circuit continuity, repair harness or connector.

GI
MA
EM
LC
EC
HE
CL
MT
AT
FA
FA
BR
ST
RS
BT
HA
EL
IDX

Diagnostic Procedure 11

SYMPTOM: Self-diagnosis cannot be performed.

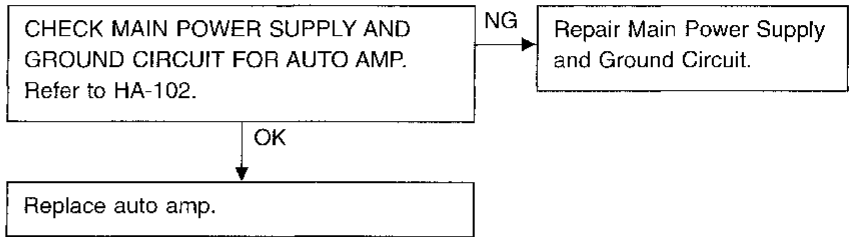

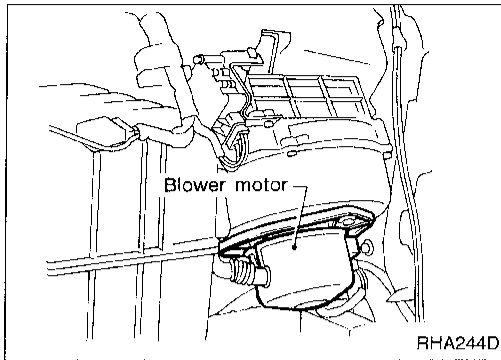

Electrical Components Inspection

BLOWER MOTOR

Confirm smooth rotation of the blower motor.

- Check that there are no foreign particles inside the intake unit.

GI

MA

FM

LC

EC

FE

CL

MT

AT

FA

RA

BR

SI

RS

BT

HA

EL

IDX

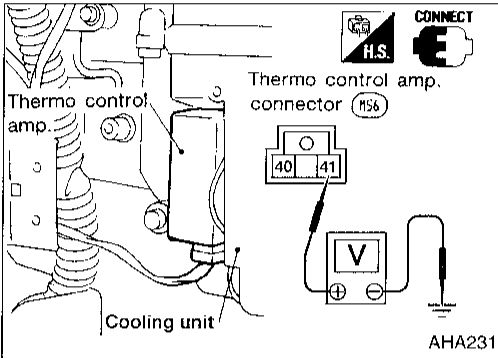

THERMO CONTROL AMP.

1. Run engine, and operate A/C system.
2. Connect the voltmeter from harness side.
3. Check thermo control amp. operation shown in the table.

Evaporator outlet air temperature °C (°F)	Thermo amp. operation	Tester
Decreasing to 2.5 - 3.5 (37 - 38)	Turn OFF	Approx. 12V
Increasing to 4.0 - 5.0 (39 - 41)	Turn ON	Approx. 0V

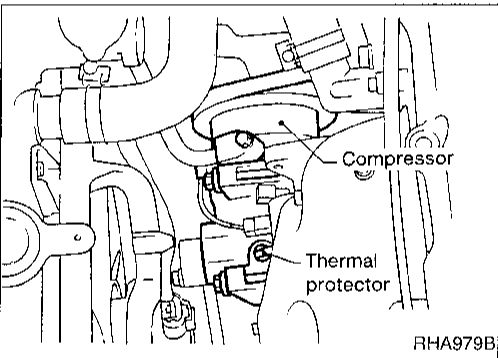

THERMAL PROTECTOR

Temperature of compressor °C (°F)	Operation
Increasing to approx. 145 - 155 (293 - 311)	Turn OFF
Decreasing to approx. 130 - 140 (266 - 284)	Turn ON

If NG, replace thermal protector.

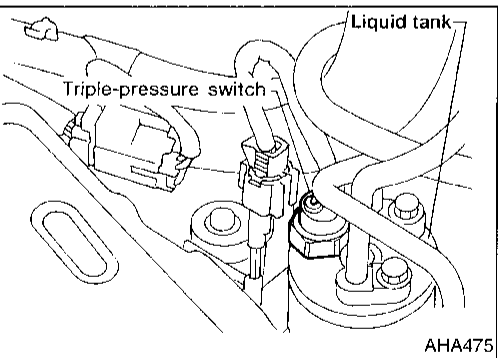

TRIPLE-PRESSURE SWITCH

	ON kPa (kg/cm ² , psi)	OFF kPa (kg/cm ² , psi)
Low-pressure side	157 - 226 (1.6 - 2.3, 23 - 33)	152.0 - 201.0 (1.55 - 2.05, 22.0 - 29.2)
Medium-pressure side*	1,422 - 1,618 (14.5 - 16.5, 206 - 235)	1,128 - 1,422 (11.5 - 14.5, 164 - 206)
High-pressure side	1,667 - 2,059 (17 - 21, 242 - 299)	2,452 - 2,844 (25 - 29, 356 - 412)

* For cooling fan motor operation.

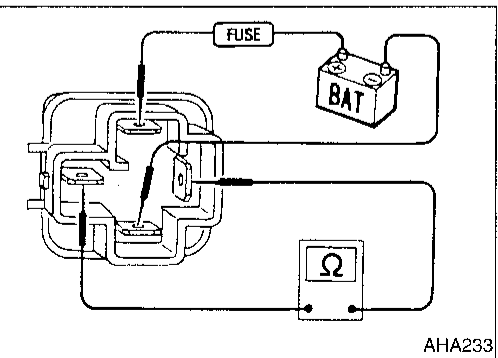

A/C RELAY AND BLOWER HI RELAY

Check circuit continuity between terminals by supplying 12 volts to coil side terminals of the relay.

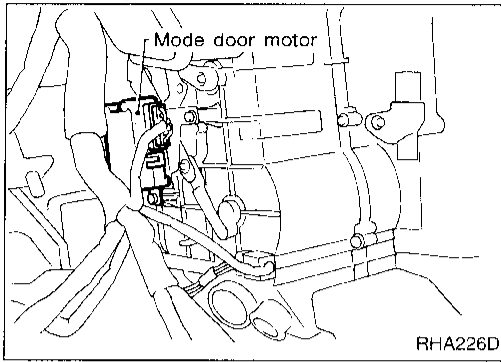

Control Linkage Adjustment

MODE DOOR

1. Install mode door motor on heater unit and connect it to main harness.
2. Set up code No. 45 in Self-diagnosis STEP 4. Refer to HA-70.
3. Move side link by hand and hold mode door in DEF mode.
4. Attach mode door motor rod to side link rod holder.
5. Make sure mode door operates properly when changing from code No. 41 to 45 by pushing DEF switch.

41	42	43	44	45	46
FACE	B/L	B/L	FOOT	F/D	DEF

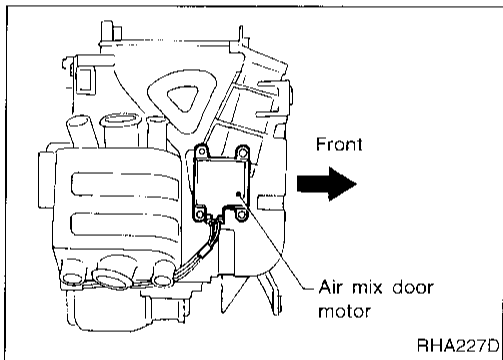

AIR MIX DOOR (Water cock)

1. Install air mix door motor on heater unit and connect it to main harness.
2. Set up code No. 41 in Self-diagnosis STEP 4. Refer to HA-70.
3. Move air mix door lever by hand and hold it in full cold position.
4. Attach air mix door lever to rod holder.
5. Make sure air mix door operates properly when changing from code No. 41 to 45 by pushing DEF switch.

41	42	43	44	45	46
Full cold			Full hot		

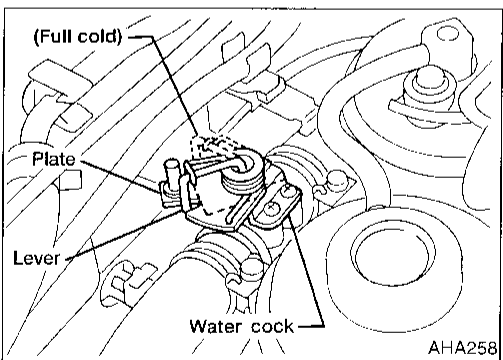

6. Set up code No. 41 in Self-diagnosis STEP 4.
7. Attach water cock cable to air mix door linkage and secure with clip.
8. Rotate and hold water cock lever and plate in the full cold position (CLOCKWISE completely).
9. Attach water cock cable to plate and secure with clip (white mark on cable housing should be centered under the retaining clip).
10. Check that water cock operates properly when changing from code No. 41 to 45 by pushing DEF switch. (After several cycles, water cock lever should be midpoint of plate opening when code No. 41 is set.)

Control Linkage Adjustment (Cont'd)

INTAKE DOOR

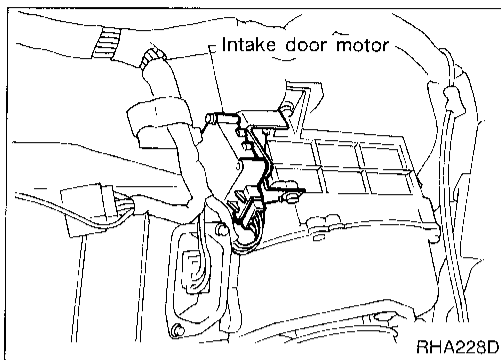

1. Install intake door motor on intake unit and connect it to main harness.
2. Set up code No. 41 in Self-diagnosis STEP 4. Refer to HA-70.
3. Move intake door link by hand and hold it in REC position.
4. Attach intake door lever to rod holder.
5. Make sure intake door operates properly when changing from code No. 41 to 45 by pushing DEF switch.

41	42	43	44	45	46
REC		20% FRE	FRE		

GE
MA
EM
LC
EC
FE
CL
MT
AT
FA
RA
BR
ST
RS
BT
HA
FL
DX

FRESH VENT DOOR

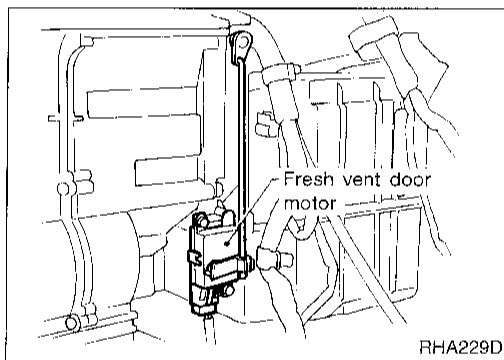

1. Install fresh vent door motor on cooling unit and connect it to main harness.
2. Set up code No. 45 in Self-diagnosis STEP 4. Refer to HA-70.
3. Move fresh vent door link by hand and hold it in CLOSE position.
4. Attach fresh vent door lever to rod holder.
5. Make sure fresh vent door operates properly when changing from code No. 41 to 45 by pushing DEF switch.

41	42	43	44	45	46
OPEN			CLOSE		

Overview of Control System

The control system consists of

- input sensors and switches,
- the automatic amplifier (microcomputer), and
- outputs.

The relationship of these components is shown in the diagram below:

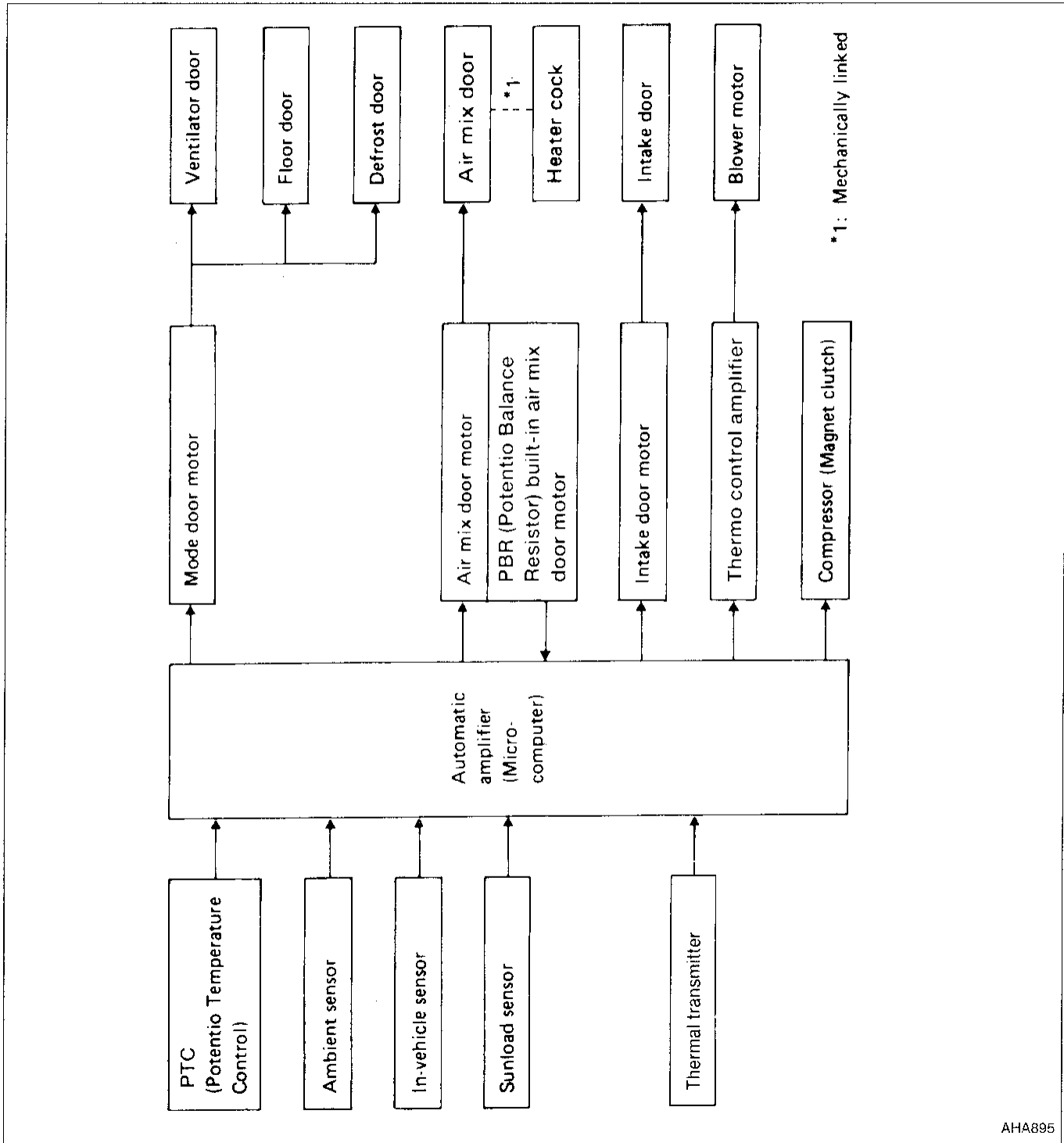

AHA895

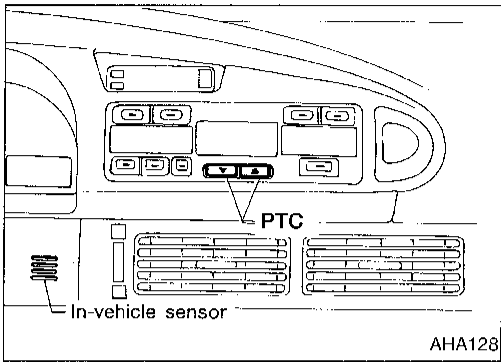

Control System Input Components

POTENTIO TEMPERATURE CONTROL (PTC)

The PTC is built into the auto amplifier. It can be set at an interval of 1°C (2°F) through both ▲ HOT and ▼ COLD control switches. Setting temperature is digitally displayed.

IN-VEHICLE SENSOR

The in-vehicle sensor is attached to the cluster lid-C. It converts variations in temperature of compartment air drawn from an aspirator into a resistance value. This value is then input into the auto amplifier.

After disconnecting in-vehicle sensor harness connector, measure resistance between sensor terminals ②⑤ and ④⑨, using the table below.

Temperature °C (°F)	Resistance kΩ
-15 (5)	12.73
-10 (14)	9.92
-5 (23)	7.80
0 (32)	6.19
5 (41)	4.95
10 (50)	3.99
15 (59)	3.24
20 (68)	2.65
25 (77)	2.19
30 (86)	1.81
35 (95)	1.51
40 (104)	1.27
45 (113)	1.07

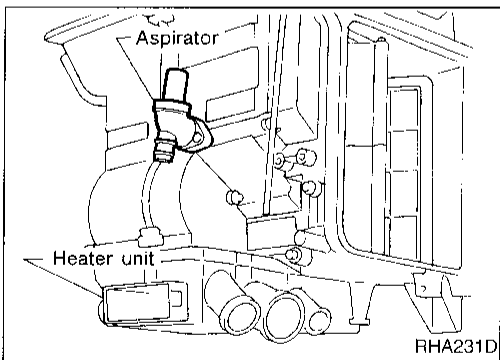

ASPIRATOR

The aspirator is located on heater unit. It produces vacuum pressure due to air discharged from the heater unit, continuously taking compartment air in the aspirator.

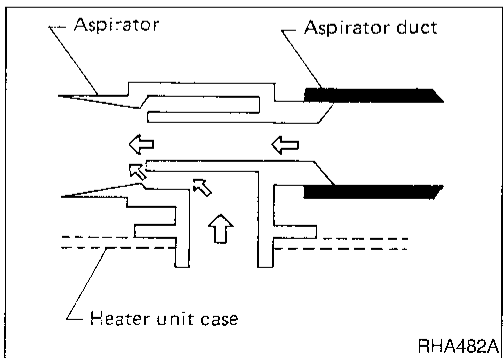

GI
MA

EM
LC

EC

FE

CL

MT

AT

FA

RA

BR

ST

RS

BT

HA

EL

IDX

Control System Input Components (Cont'd)

AMBIENT SENSOR

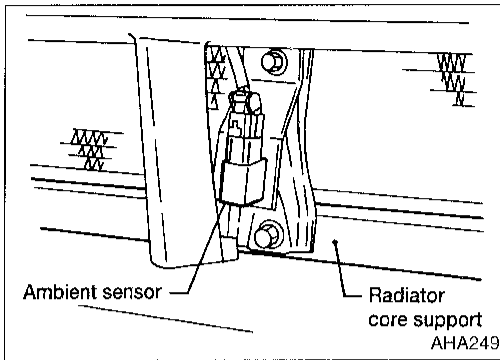

The ambient sensor is attached to the radiator core support. It detects ambient temperature and converts it into a resistance value which is then input to the auto amplifier.

After disconnecting ambient sensor harness connector, measure resistance between sensor terminals ③④ and ③⑨, using the table below.

Temperature °C (°F)	Resistance kΩ
-15 (5)	12.73
-10 (14)	9.92
-5 (23)	7.80
0 (32)	6.19
5 (41)	4.95
10 (50)	3.99
15 (59)	3.24
20 (68)	2.65
25 (77)	2.19
30 (86)	1.81
35 (95)	1.51
40 (104)	1.27
45 (113)	1.07

SUNLOAD SENSOR

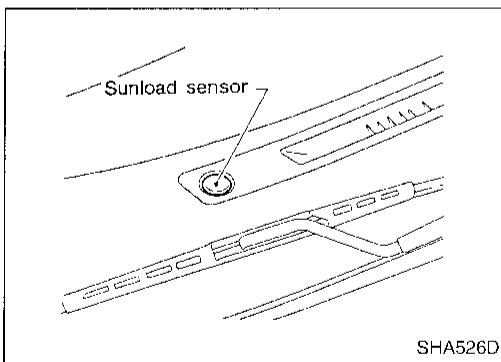

The sunload sensor is located on the right defroster grille. It detects sunload entering through windshield by means of a photo diode. The sensor then converts it into a current value which is then input to the auto amplifier.

Measure voltage between sensor terminals ②⑥ and ③⑧, using the table below.

Input current mA	Output voltage V
0	5.0
0.1	4.1
0.2	3.1
0.3	2.2
0.4	1.3
0.5	0.4

- When checking sunload sensor, select a place where sun shines directly on it.

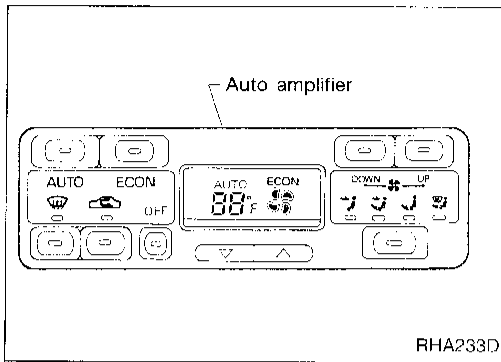

Control System Automatic Amplifier (Auto amp.)

The auto amplifier has a built-in microcomputer which processes information sent from various sensors needed for air conditioner operation. The air mix door motor, mode door motor, intake door motor, blower motor and compressor are then controlled.

The auto amplifier is unitized with control mechanisms. Signals from various switches and Potentio Temperature Control (PTC) are directly entered into auto amplifier.

Self-diagnostic functions are also built into the auto amplifier to provide quick check of malfunctions in the auto air conditioner system.

CI
HA
EK
LG
EC
EE
CL
MT
AT
BA
RA
BR
ST
RS
BT
HA
EL
DX

AMBIENT TEMPERATURE INPUT PROCESS

The automatic amplifier includes a processing circuit for the ambient sensor input. When the temperature detected by the ambient sensor increases quickly, the processing circuit allows the auto amp. to recognize an ambient temperature increase of only 0.2°C (0.4°F) per 100 seconds.

As an example, consider stopping for a cup of coffee after high speed driving. Even though the actual ambient temperature has not changed, the temperature detected by the ambient sensor will increase because heat radiated from the engine compartment can radiate to the front grille area (where the ambient sensor is located).

SUNLOAD INPUT PROCESS

The auto amp. also includes a processing circuit to average variations in detected sunload over a period of time. This prevents drastic swings in the ATC system operation due to small or quick variations in detected sunload.

For example, consider driving along a road bordered by an occasional group of large trees. The sunload detected by the sunload sensor will vary whenever the trees obstruct the sunlight. The processing circuit averages the detected sunload over a period of time. The (insignificant) effect of the trees momentarily obstructing the sunlight does not cause any change in the ATC system operation. On the other hand, shortly after entering a long tunnel, the system will recognize the change in sunload, and the system will react accordingly.

Control System Output Components

AIR MIX DOOR CONTROL (Automatic temperature control)

Component parts

Air mix door control system components are:

- Auto amplifier
- Air mix door motor (PBR)
- In-vehicle sensor
- Ambient sensor
- Sunload sensor

System operation

Temperature set by Potentio Temperature Control (PTC) is compensated through setting temperature correction circuit to determine target temperature.

Auto amplifier will operate air mix door motor to set air conditioner system in HOT or COLD position, depending upon relationship between conditions.

Control System Output Components (Cont'd)

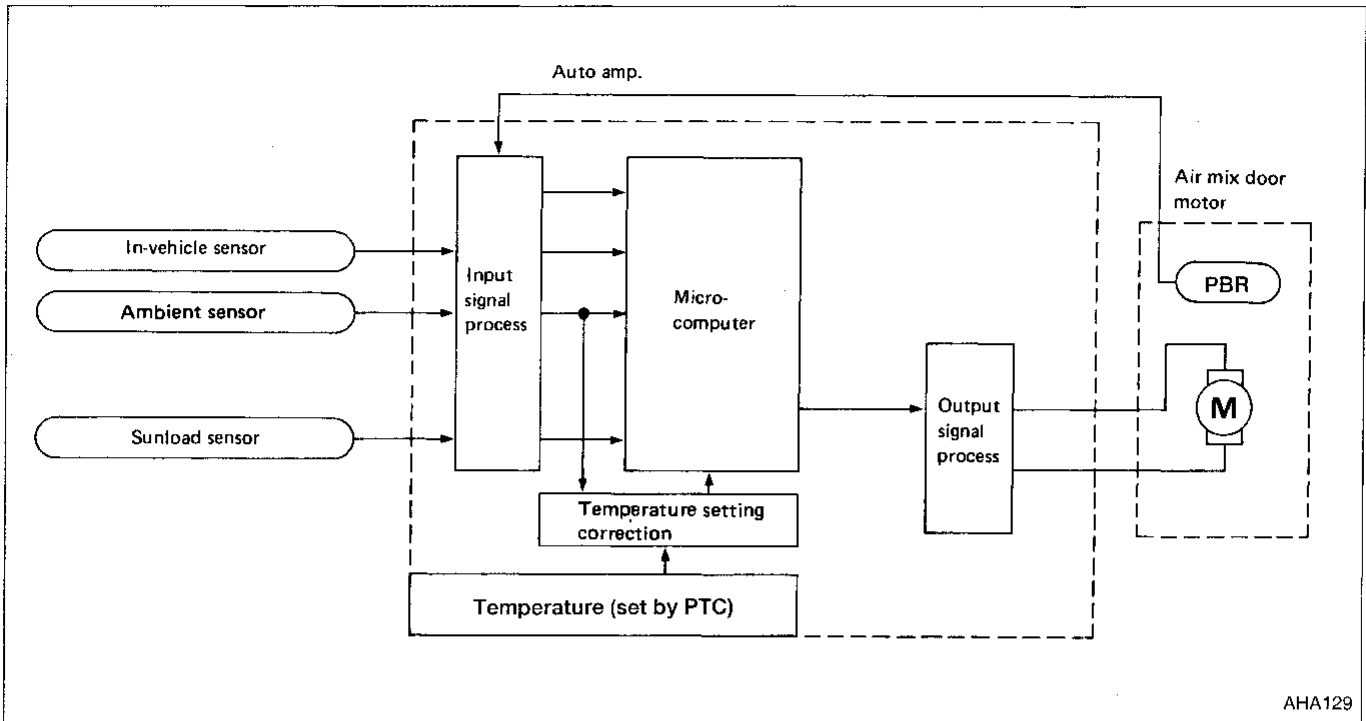

AHA129

Air mix door control specification

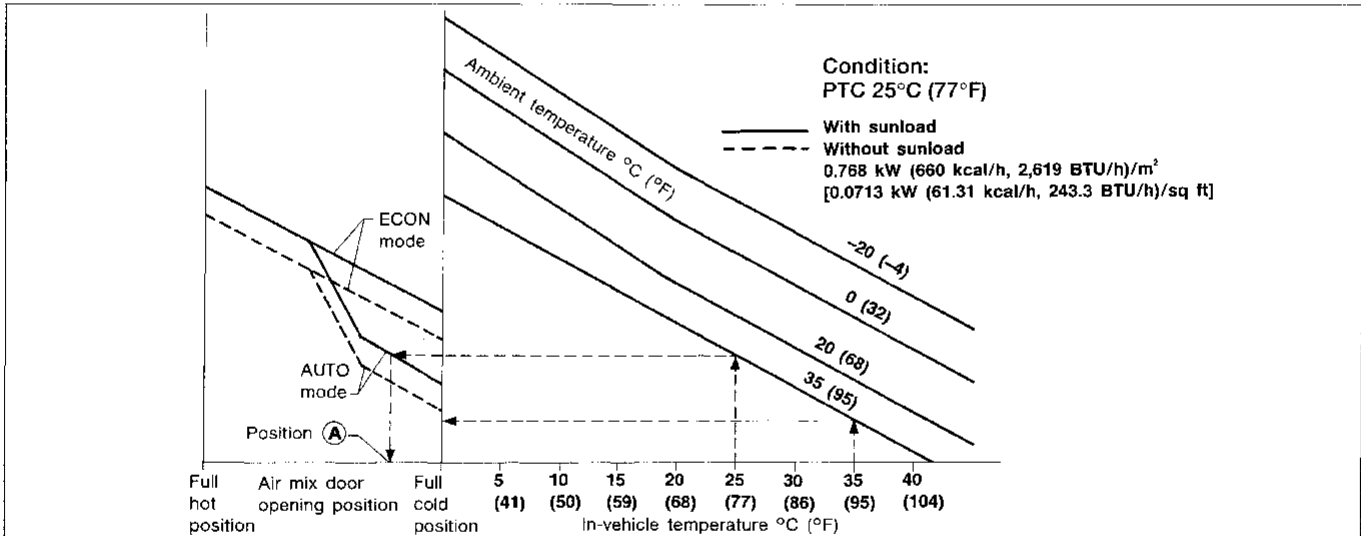

Example:

- If temperature setting is set at 25°C (77°F) under no sunload condition when ambient and in-vehicle temperature is 35°C (95°F), air mix door is initially automatically set in full cold position.
- Within some period, in-vehicle temperature will lower towards the objective temperature, and the air mix door position will shift incrementally towards the hot side and finally stay in this position (A) if mode is at AUTO position (No. ECON mode). Air mix door opening position is always fed back to auto amplifier by PBR built-in air mix door motor.

AHA130

Control System Output Components (Cont'd)

AIR MIX DOOR MOTOR

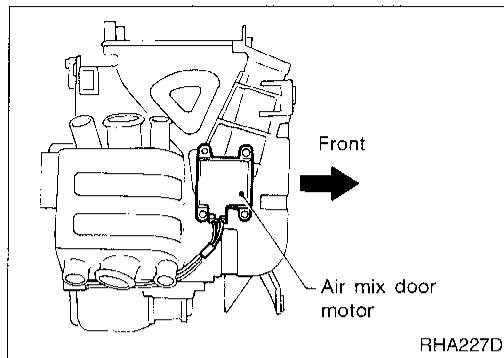

The air mix door motor is attached to the bottom of the heater unit. It rotates so that the air mix door is opened to a position set by the auto amplifier. Motor rotation is conveyed through a shaft and air mix door position. It is then fed back to the auto amplifier by PBR built-in air mix door motor.

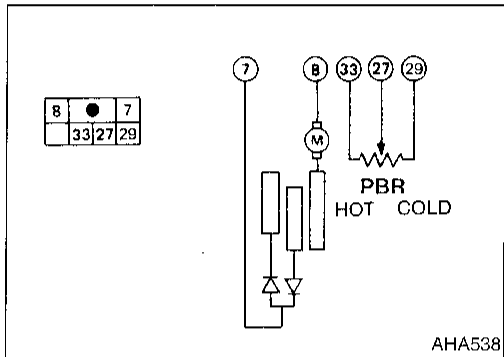

Air mix door operation

7	8	Air mix door operation	Direction of lever movement
⊕	⊖	COLD → HOT	Clockwise (Toward passenger compartment)
⊖	⊖	STOP	STOP
⊖	⊕	HOT → COLD	Counterclockwise (Toward engine compartment)

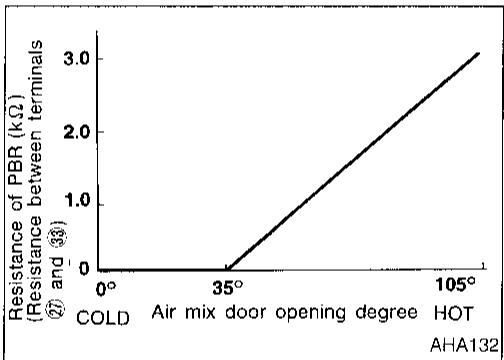

PBR characteristics

Measure resistance between terminals 27 and 33 at vehicle harness side.

GI

NA

EM

LC

EC

FE

CL

MT

AT

HA

HA

BR

ST

RS

BT

HA

EL

IDX

Control System Output Components (Cont'd)

MODE DOOR CONTROL

Component parts

Mode door control system components are:

- Auto amplifier
- Mode door motor
- PBR
- In-vehicle sensor
- Ambient sensor
- Sunload sensor

System operation

The auto amplifier computes the air discharge conditions according to the ambient temperature and the in-vehicle temperature. The computed discharge conditions are then corrected for sunload to determine which outlets air will flow through into the passenger compartment.

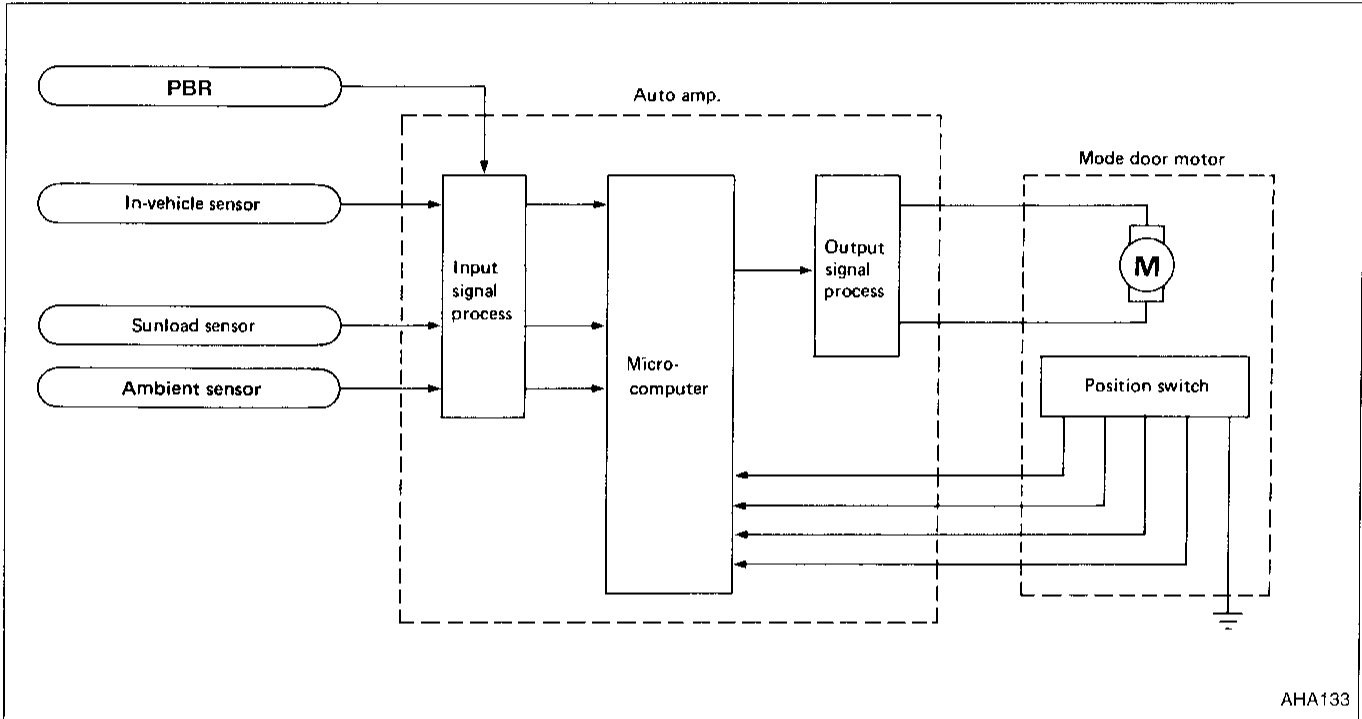

AHA133

Mode door control specification

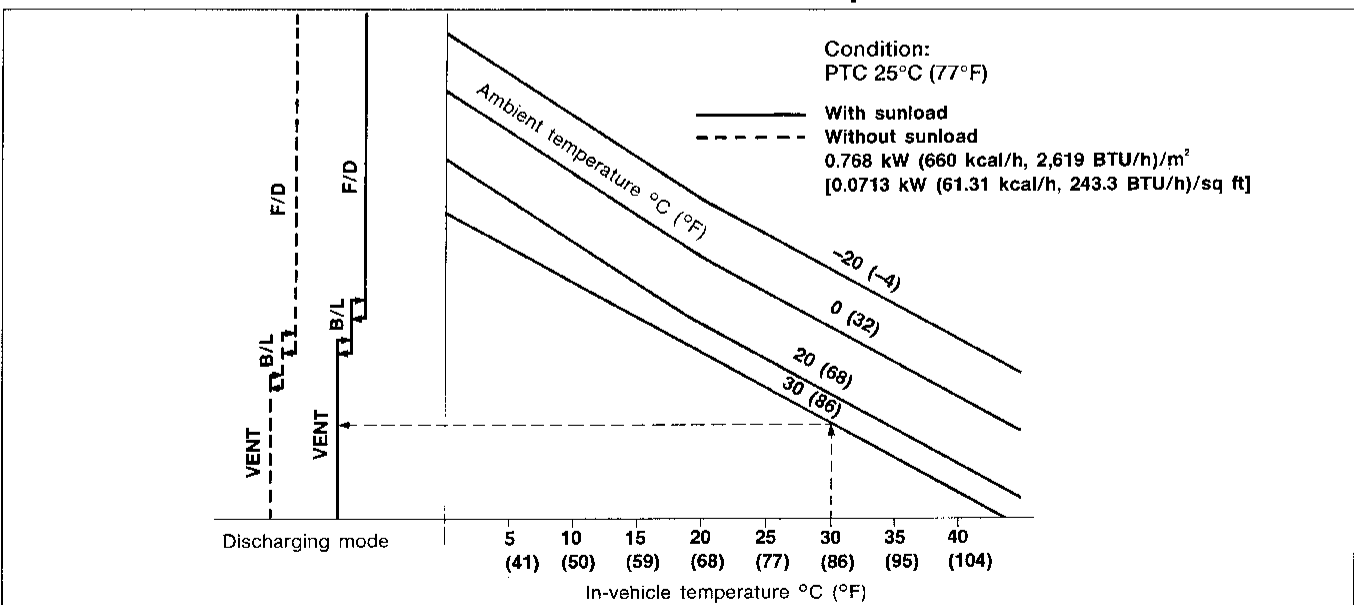

Example:

- If temperature setting is set at 25°C (77°F) under no sunload condition when ambient and in-vehicle temperature are 30°C (86°F), mode door is set automatically at VENT position.

AHA134

Control System Output Components (Cont'd)

MODE DOOR MOTOR

The mode door motor is attached to the heater unit. It rotates so that air is discharged from the outlet set by the auto amplifier. Motor rotation is conveyed to a link which activates the mode door.

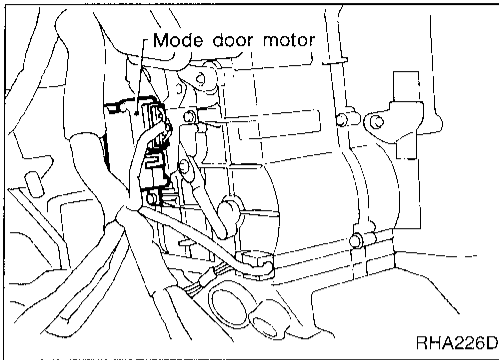

6	5	Mode door operation	Direction of side link rotation
⊕	⊖	FACE → DEF	Clockwise
⊖	⊖	STOP	STOP
⊖	⊕	DEF → FACE	Counterclockwise

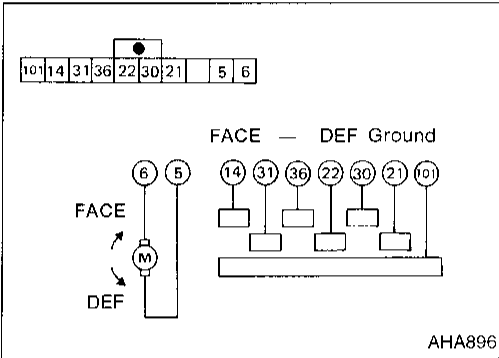

INTAKE DOOR CONTROL

Components parts

Intake door control system components are:

- Auto amplifier
- Intake door motor
- PBR
- In-vehicle sensor
- Ambient sensor
- Sunload sensor

System operation

The intake door control determines intake door position based on the ambient temperature and the in-vehicle temperature. When the ECON, DEF, or OFF button is pushed, the auto amplifier sets the intake door at the FRESH position.

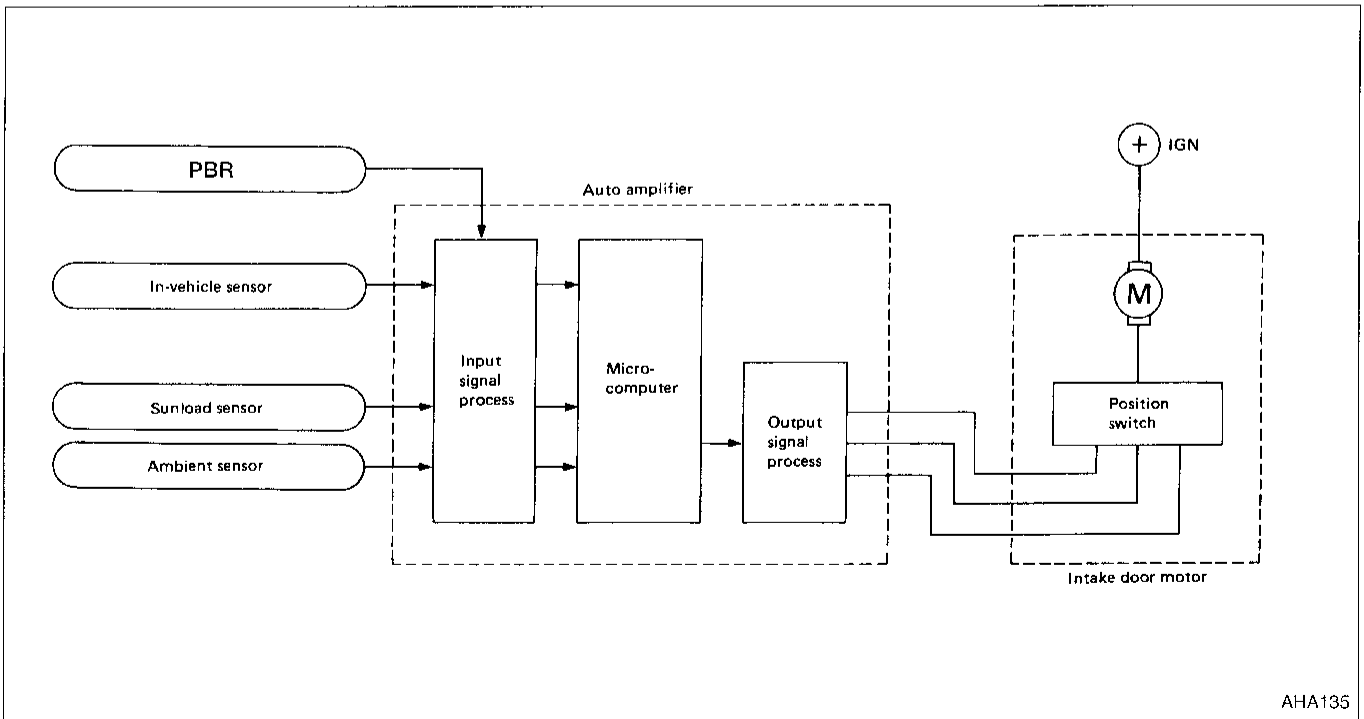

Control System Output Components (Cont'd)

Intake door control specification

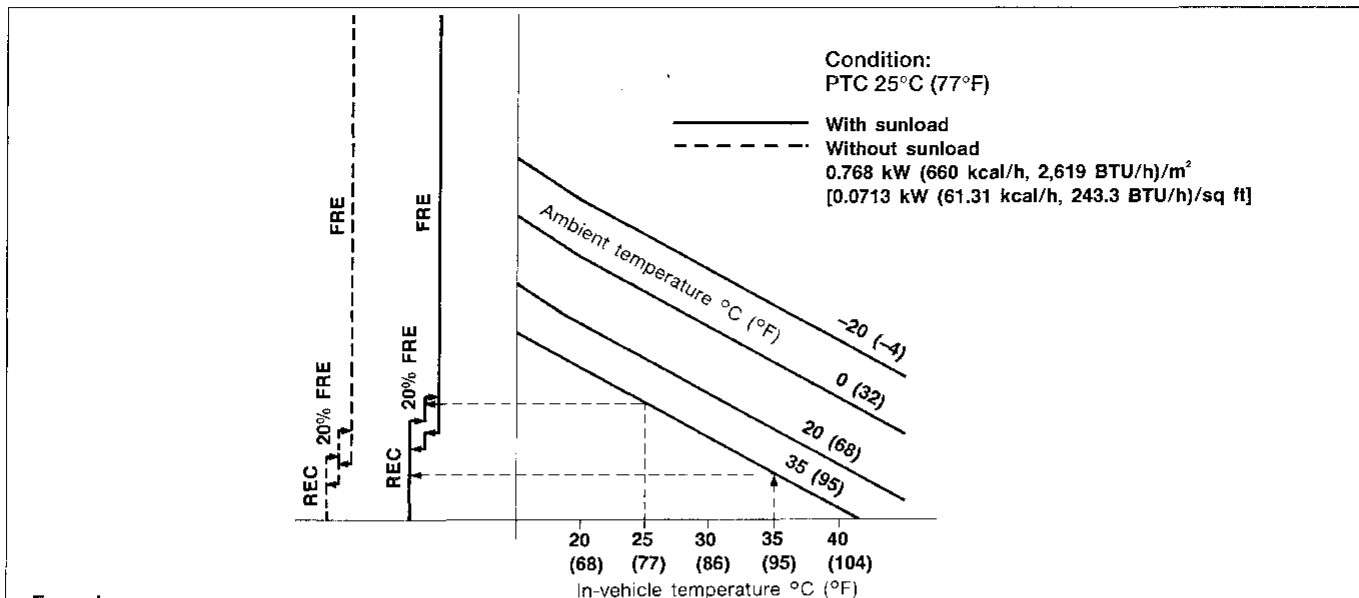

Example:

- If temperature setting is set at 25°C (77°F) under no sunload condition when ambient and in-vehicle temperature are 35°C (95°F), intake door is set automatically at REC position to make in-vehicle temperature cool down efficiently.
- In-vehicle temperature will lower and when 25°C (77°F) is reached, intake door will shift to 20% FRE position.

AHA136

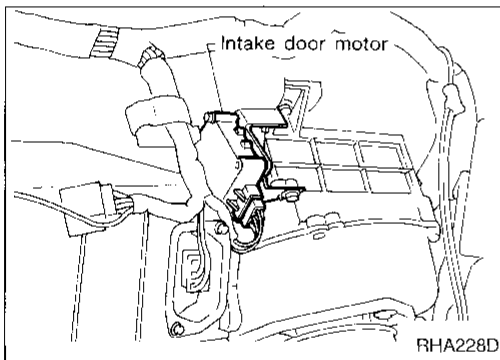

INTAKE DOOR MOTOR

The intake door motor is attached to the intake unit. It is set by the auto amplifier so that fresh air or interior air will be drawn into the passenger compartment. Motor rotation is conveyed to a lever which activates the intake door. Intake door motor operation

3	4	Intake door operation	Movement of link rotation
⊕	⊖	REC → FRE	Clockwise
⊖	⊖	STOP	STOP
⊖	⊕	FRE → REC	Counterclockwise

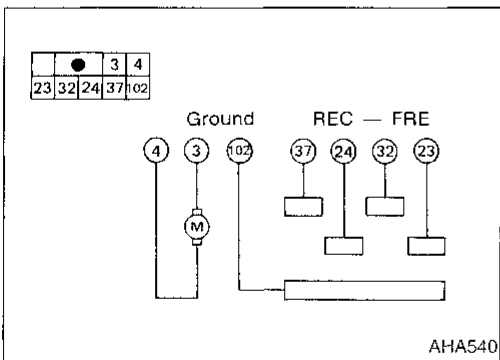

AHA540

Control System Output Components (Cont'd)

FAN SPEED CONTROL

Component parts

Fan speed control system components are:

- Auto amplifier
- Fan control amplifier
- PBR
- In-vehicle sensor
- Ambient sensor
- Sunload sensor
- Blower Hi-relay
- Thermal transmitter

System operation

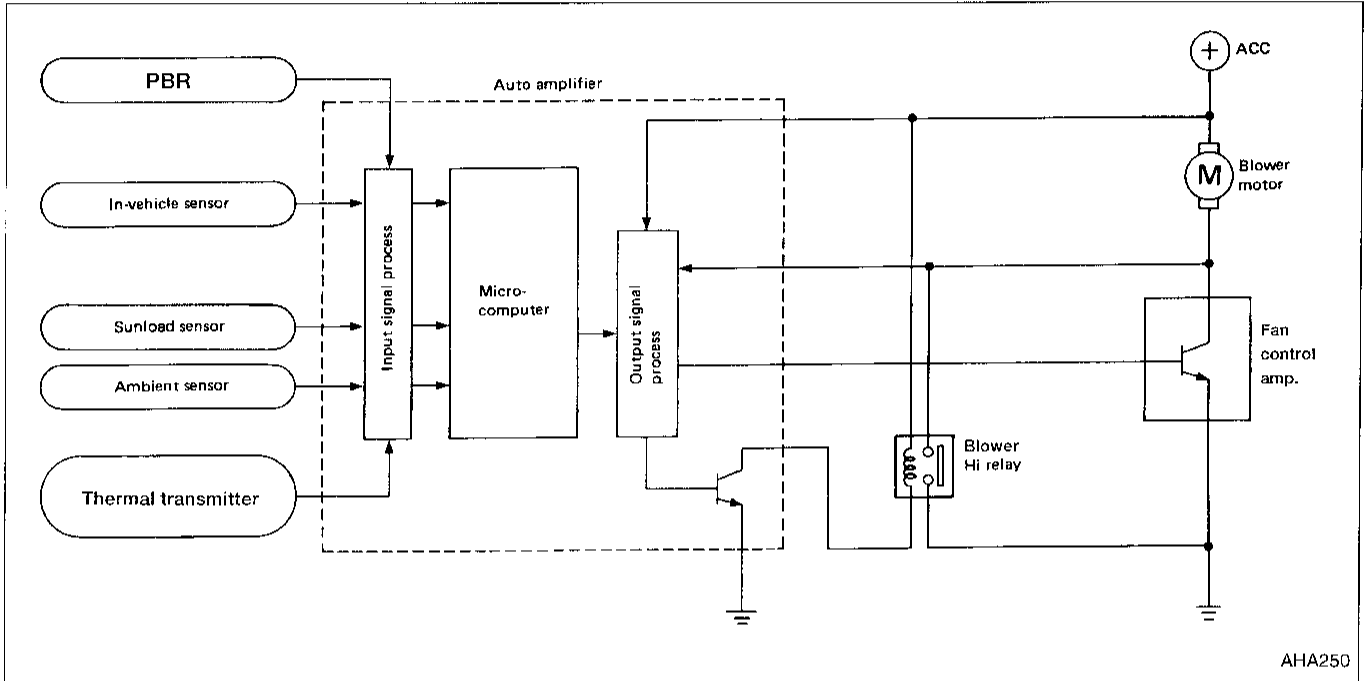

AUTOMATIC MODE

In the automatic mode, the blower motor speed is calculated by the automatic amplifier based on inputs from the:

- PBR
- in-vehicle sensor
- sunload sensor
- ambient sensor

The blower motor applied voltage ranges from approximately 4.5 volts (lowest speed) to 12 volts (highest speed).

To control blower speed (in the range of 4.5V to 10.5V), the automatic amplifier supplies a signal to the thermo control amplifier. Based on this signal, the thermo control amplifier controls the current flow from the blower motor to ground. If the computed blower voltage (from the automatic amplifier) is above 10.5 volts, the high blower relay is activated. The high blower relay provides a direct path to ground (bypassing the blower amplifier), and the blower motor operates at high speed.

STARTING FAN SPEED CONTROL

Start up from COLD SOAK condition (Automatic mode)

In a cold start up condition where the engine coolant temperature is below 50°C (122°F), the blower will not operate for a short period of time (up to 180 seconds). The exact start delay time varies depending on the ambient and engine coolant temperature.

In the most extreme case (very low ambient) the blower starting delay will be 180 seconds. After this delay, the blower will operate at low speed until the engine coolant temperature rises above 50°C (122°F), at which time the blower speed will increase to the objective speed.

Start up from normal or HOT SOAK condition (Automatic mode)

The blower will begin operation momentarily after the AUTO button is pushed. The blower speed will gradually rise to the objective speed over a time period of 5 seconds or less (actual time depends on the objective blower speed).

Control System Output Components (Cont'd)

BLOWER SPEED COMPENSATION

Sunload

When the in-vehicle temperature and the set temperature are very close, the blower will operate at low speed. The low speed varies depending on the sunload. During conditions of high sunload, the blower low speed is normal low speed (approx. 5.5V). During lesser sunload conditions, the low speed will drop to "low" low speed (approx. 4.5V).

Fan speed control specification

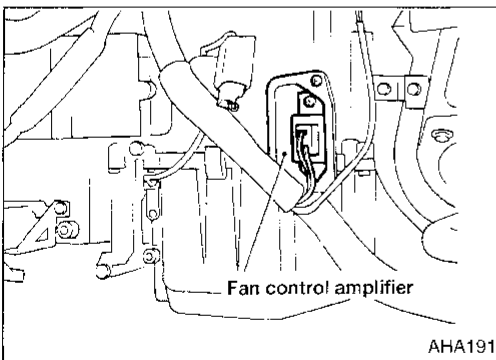
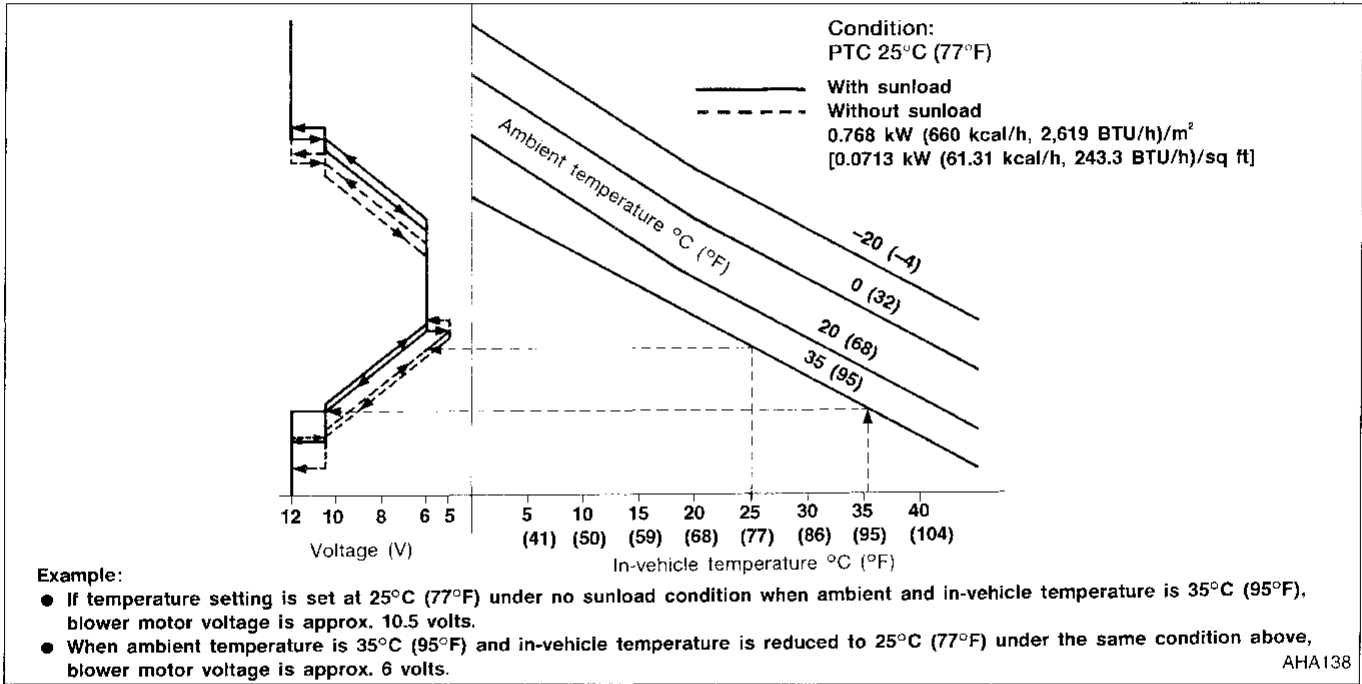

FAN CONTROL AMPLIFIER

The fan control amplifier is located on the cooling unit. It amplifies a 12-step base current flowing from the auto amplifier to change the blower speed within the range of 5V to 10.5V. Above 10.5 volts, the high relay applies a direct ground to the blower motor.

Control System Output Components (Cont'd)

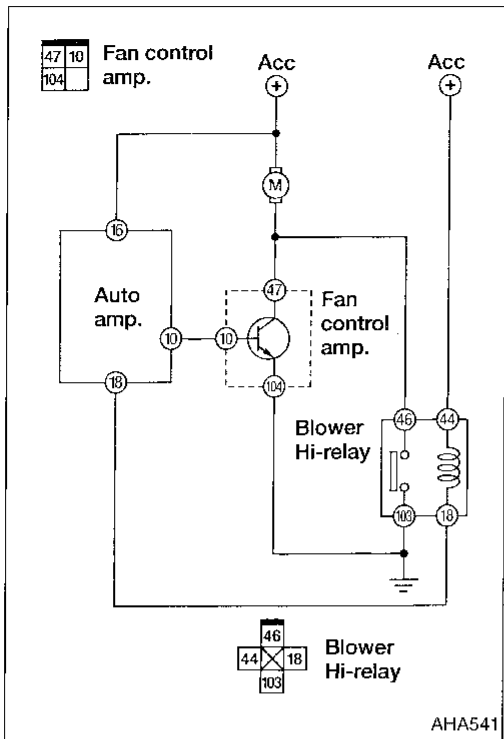

GI
MA
EM
LG
EC
FE
CL
MT

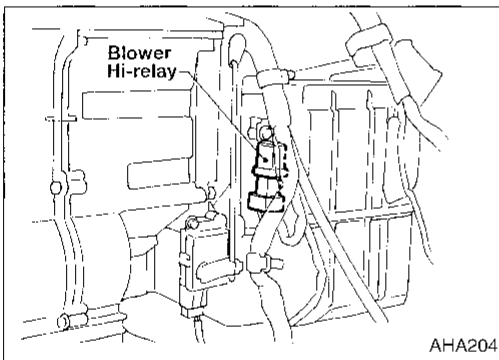

BLOWER HI-RELAY

The blower Hi-relay is located on the cooling unit. It receives a signal from the auto amplifier to operate the blower motor at high speed.

AT
FA
RA

MAGNET CLUTCH CONTROL

The ECM (ECCS control module) controls compressor operation using inputs from the throttle position sensor and auto amplifier.

BR
ST
RS
BT

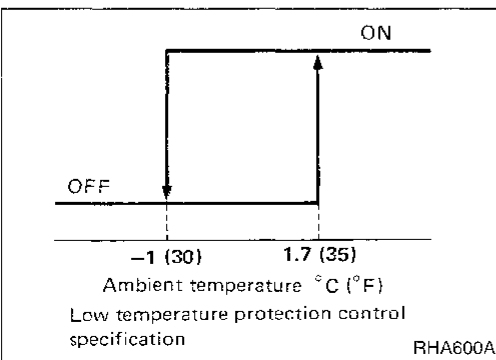

Low temperature protection control

The auto amplifier will tell the ECM (ECCS control module) to turn the compressor ON or OFF. This signal is based on input from the ambient temperature sensor.

Acceleration cut control

The ECM (ECCS control module) will turn the compressor ON or OFF based on the signal from the throttle position sensor.

HA
EL
DX

Checking Refrigerant Leaks

PRELIMINARY CHECK

Perform a visual inspection of all refrigeration parts, fittings, hoses, and components for signs of A/C lubricant leakage, damage and corrosion.

PRECAUTIONS FOR HANDLING LEAK DETECTOR

When performing a refrigerant leak check, use a J39400 A/C leak detector or equivalent. Ensure that the instrument is calibrated and set properly per the operating instructions.

The leak detector is a delicate device. In order to use the leak detector properly, read the operating instructions and perform any specified maintenance.

Other gases in the work area or substances on the A/C components, for example, anti-freeze, windshield washer fluid, solvents and cleaners, may falsely trigger the leak detector. Make sure the surfaces to be checked are clean. Do not allow the sensor tip of the detector to come into contact with any substance. This can also cause false readings and may damage the detector.

1. Position probe approximately 5mm (0.20 in) away from point to be checked.
2. When testing, circle each fitting completely with probe.
3. Move probe along component approximately 25-50mm (1-2 in.)/sec.

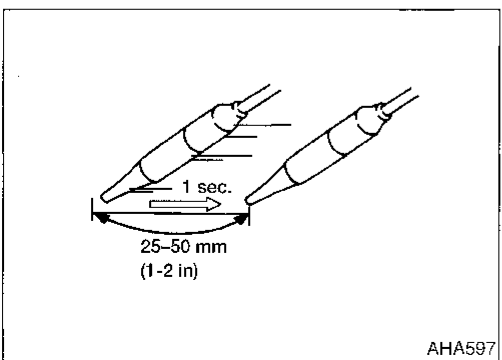
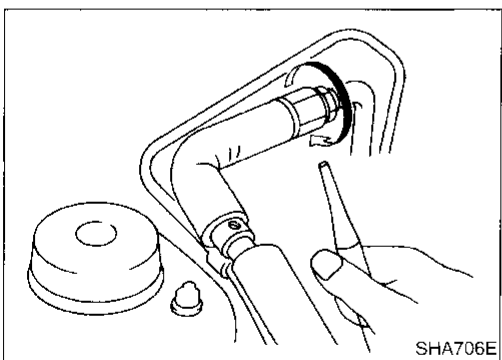
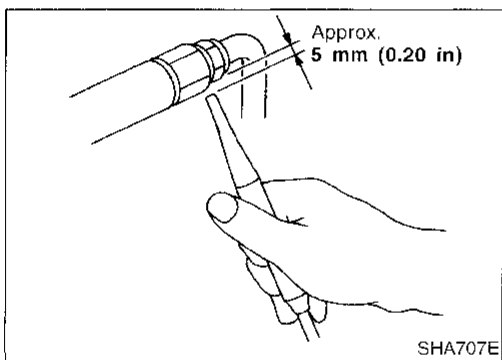
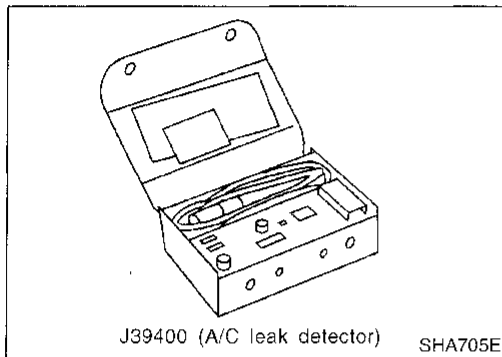

Checking Refrigerant Leaks (Cont'd)

Checking procedure

To prevent inaccurate or false readings, make sure there is no refrigerant vapor or tobacco smoke in the vicinity of the vehicle. Perform the leak test in calm area (low air/wind movement) so that the leaking refrigerant is not dispersed.

1. Charge the system with the specified amount of refrigerant.
2. Run the engine with the A/C compressor ON for at least 2 minutes.
3. Stop engine.

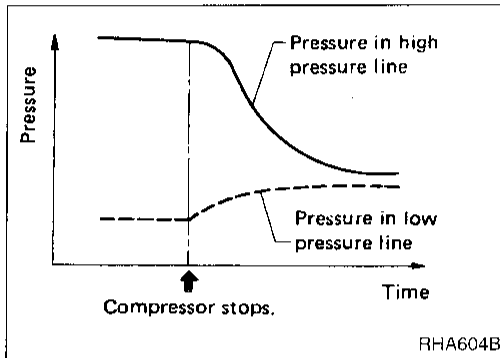

Refrigerant leaks should be checked immediately after stopping the engine. Begin with the leak detector on the high-pressure line. The pressure in the high-pressure line will gradually drop after refrigerant circulation stops and pressure in the low-pressure line will gradually rise, as shown in the graph. Leaks are more easily detected when pressure is high.

4. Conduct the leak test from the high side to the low side at points (a) through (k). Refer to HA-140. Perform a leak check for the following areas carefully. Clean the component to be checked and move the leak detector probe completely around the connection/component.

- **Compressor**

Check the fittings of high and low-pressure hoses, relief valve, and shaft seal.

- **Liquid tank**

Check the pressure switch, tube fitting and the fusible plug mounts.

- **Service valves**

Check all around the service valves. Ensure service valve caps are secured on the service valves (to prevent leaks).

- **Cooling unit**

Turn blower fan on High for at least 15 seconds to dissipate any refrigerant trace in the cooling unit. Insert the leak detector probe into the drain hose immediately after stopping engine. (Keep the probe inserted for at least ten seconds.)

5. If the leak detector detects a leak, confirm using soapy water.
6. Discharge A/C system and repair the leaking fitting or component as necessary.
7. Evacuate and recharge A/C system and perform the leak test to confirm no refrigerant leaks.

R-134a Service Procedure

DISCHARGING REFRIGERANT

WARNING:

Avoid breathing A/C refrigerant and lubricant vapor or mist. Exposure may irritate eyes, nose and throat. Remove R-134a from the A/C system using certified service equipment meeting requirements of SAE J2210 (R-134a recycling equipment) or J2209 (R-134a recovery equipment). If accidental system discharge occurs, ventilate work area before resuming service. Additional health and safety information may be obtained from refrigerant and lubricant manufacturers.

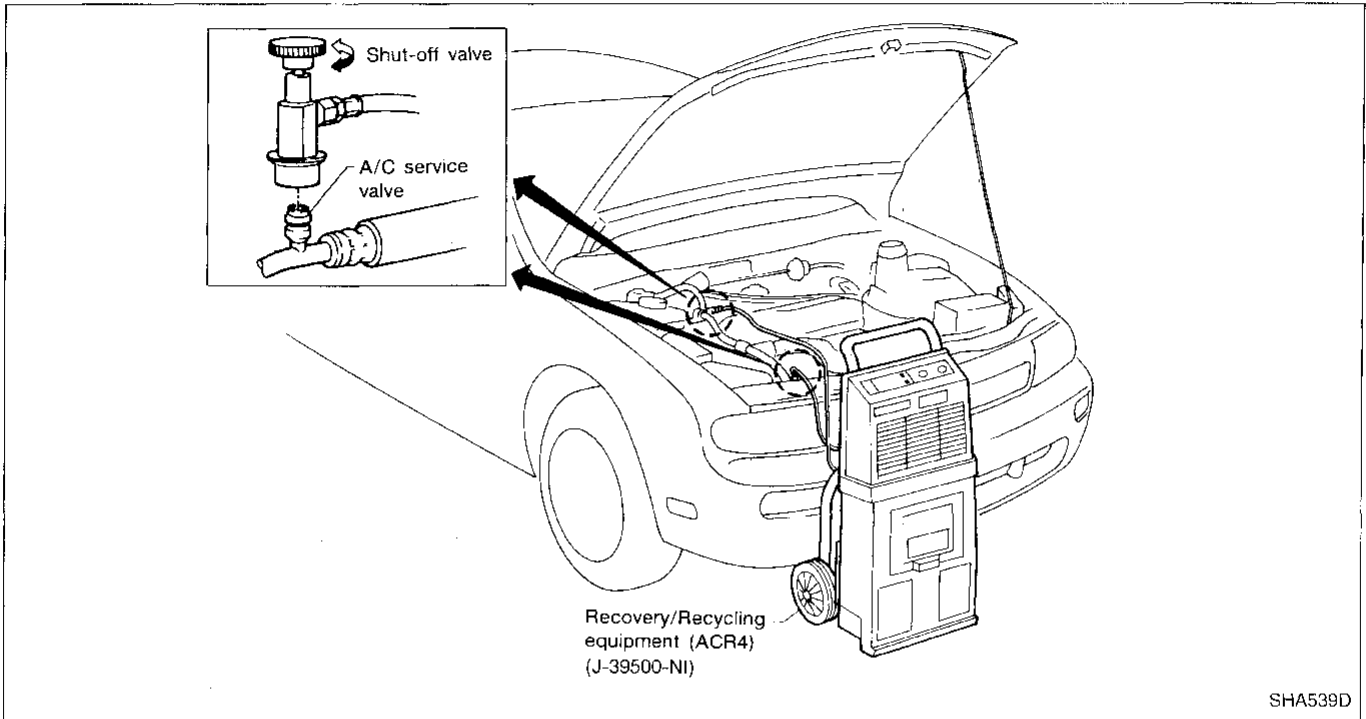

EVACUATING SYSTEM AND CHARGING REFRIGERANT

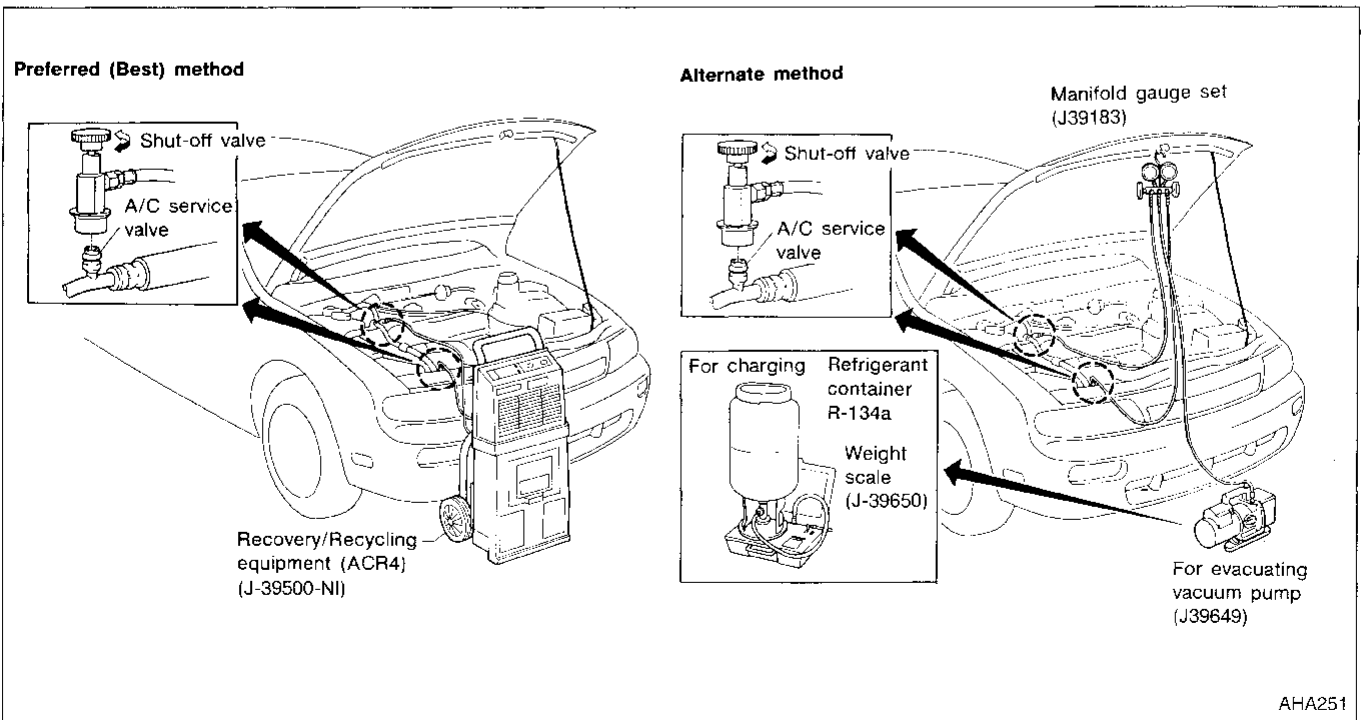

R-134a Service Procedure (Cont'd)

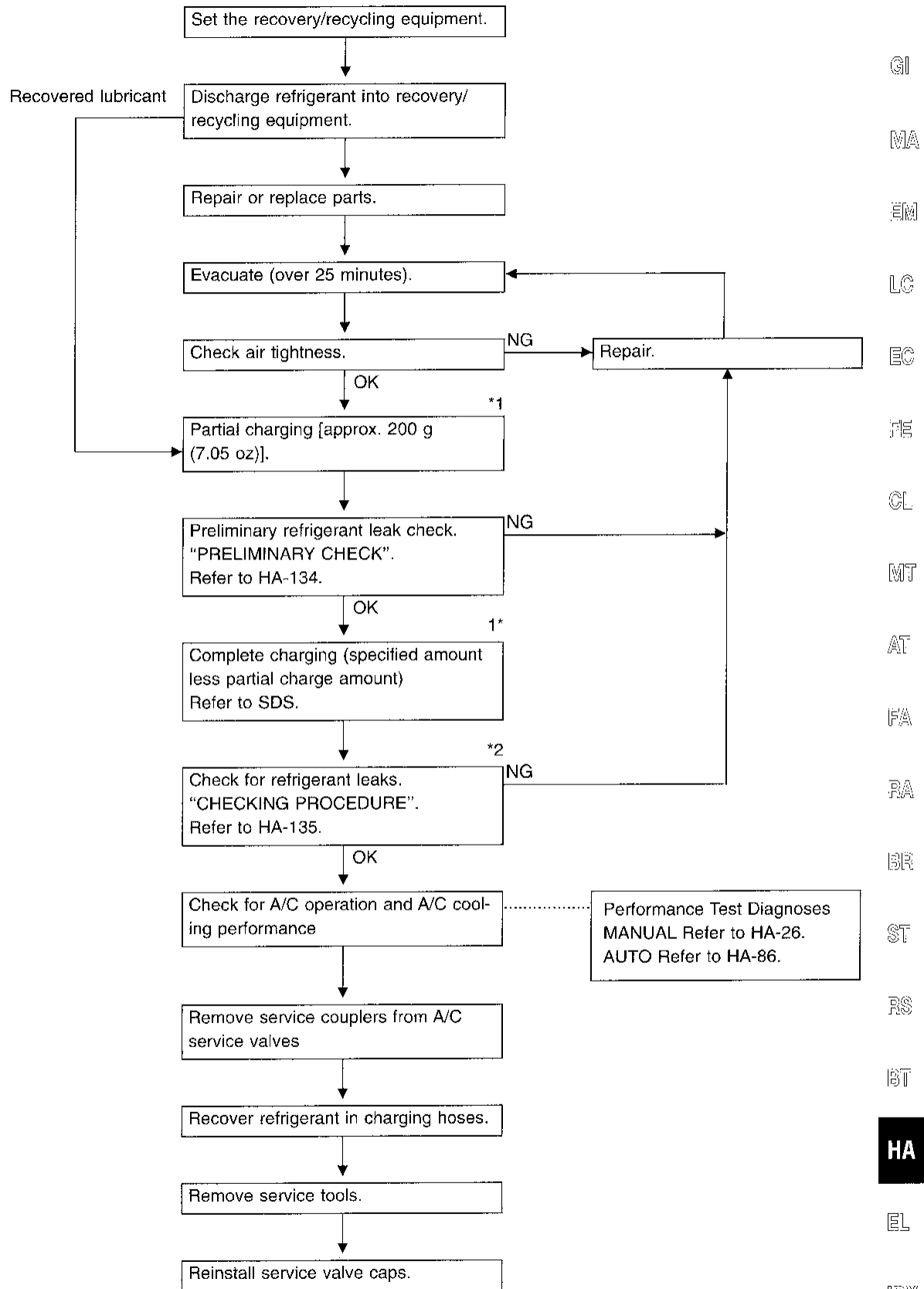

Note: *1 Before charging refrigerant, ensure engine is OFF.

*2 Before checking for leaks, start engine to activate air conditioner system then turn engine OFF. Service valve caps must be installed to prevent leakage.

Compressor Lubricant Quantity

The lubricant used to lubricate the compressor circulates through the system with the refrigerant. Whenever any A/C component is replaced or gas leakage occurs, lubricant must be added.

If lubricant quantity is not maintained properly, the following malfunctions may result:

- Lack of lubricant: May lead to a seized compressor
- Excessive lubricant: Inadequate cooling (thermal exchange interference)

LUBRICANT

Name: Nissan A/C System Lubricant Type R

Part No.: KLH00-PAGR0

CHECKING AND ADJUSTING

Adjust the lubricant quantity according to the flowchart shown below.

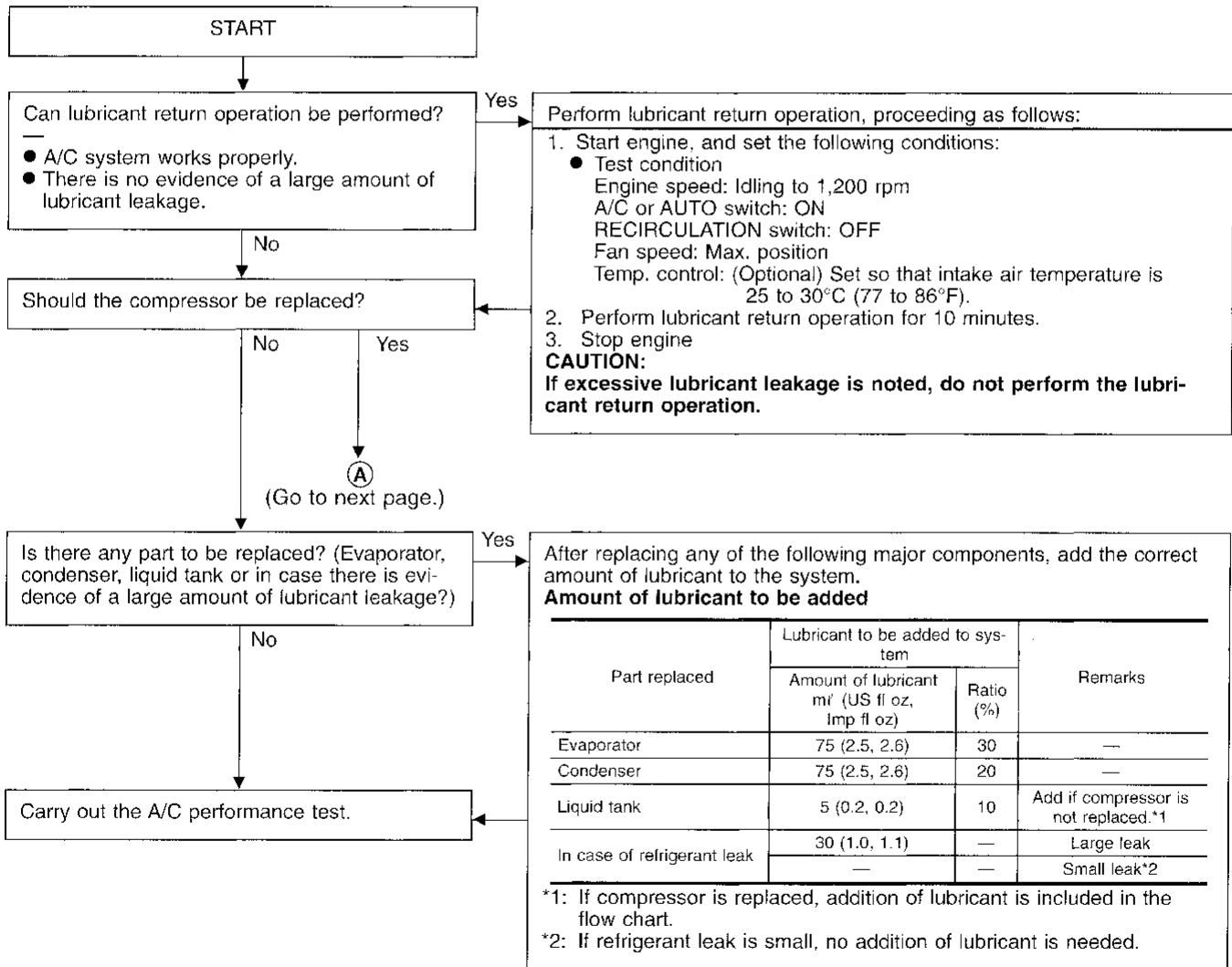

Compressor Lubricant Quantity (Cont'd)

A

1. Discharge refrigerant into refrigerant recovery/recycling equipment. Measure lubricant discharged into the recovery/recycling equipment.
2. Drain the lubricant from the old (removed) compressor into a graduated container and record the amount of lubricant drained.
3. Drain the lubricant from the new compressor into a separate, clean container.
4. Measure an amount of new lubricant equal to amount drained from old compressor. Add this lubricant to new compressor through the suction port opening.
5. Measure an amount of new lubricant equal to the amount recovered during discharging. Add this lubricant to new compressor through the suction port opening.
6. If the liquid tank also needs to be replaced, add an additional 5 ml (0.2 US fl oz, 0.2 Imp fl oz) of lubricant at this time.
Do not add this 5 ml (0.2 US fl oz, 0.2 Imp fl oz) of lubricant if only replacing the compressor.

Lubricant adjusting procedure for compressor replacement

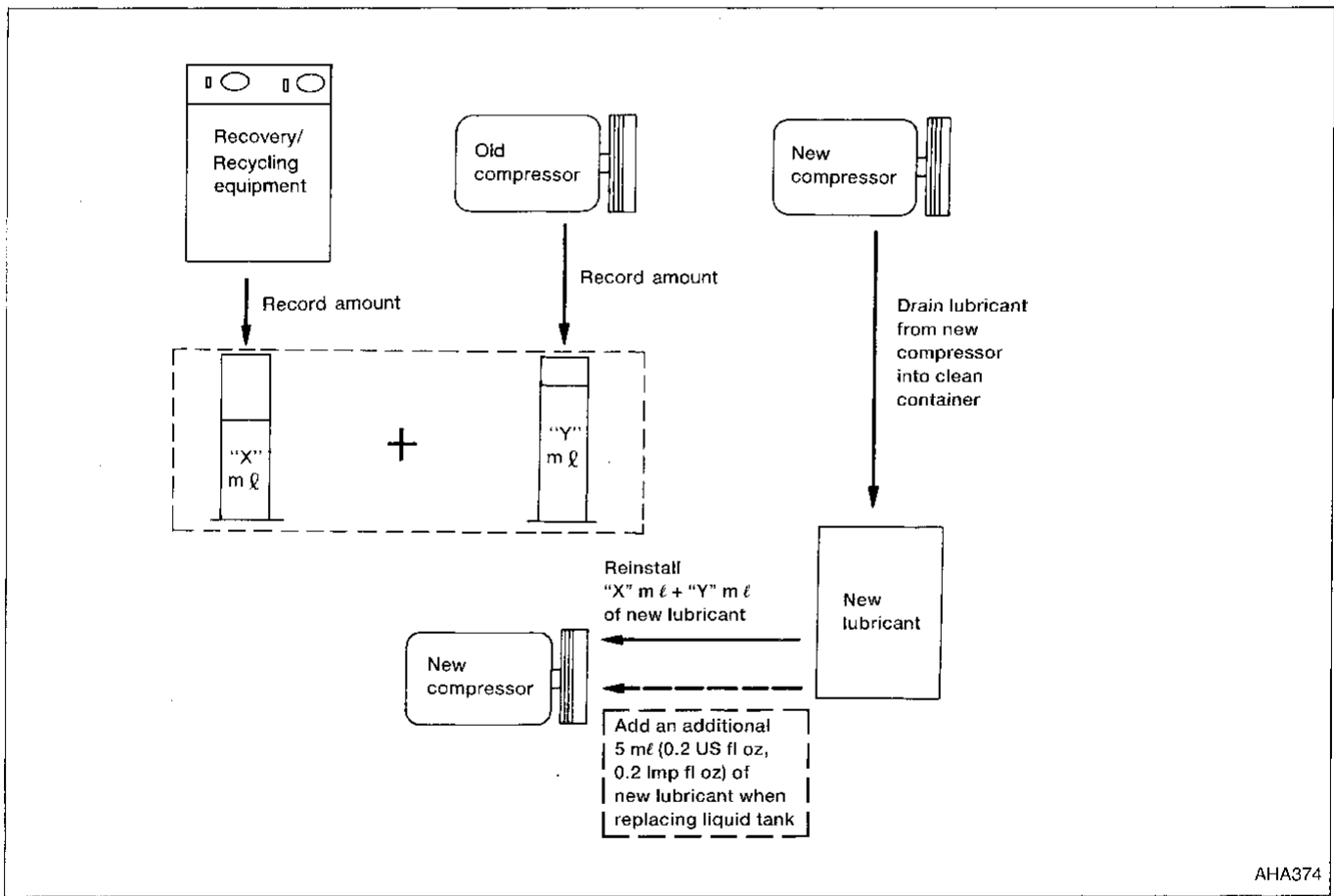

Refrigerant Lines

- Refer to HA-4.

SEC. 214•271•274•276

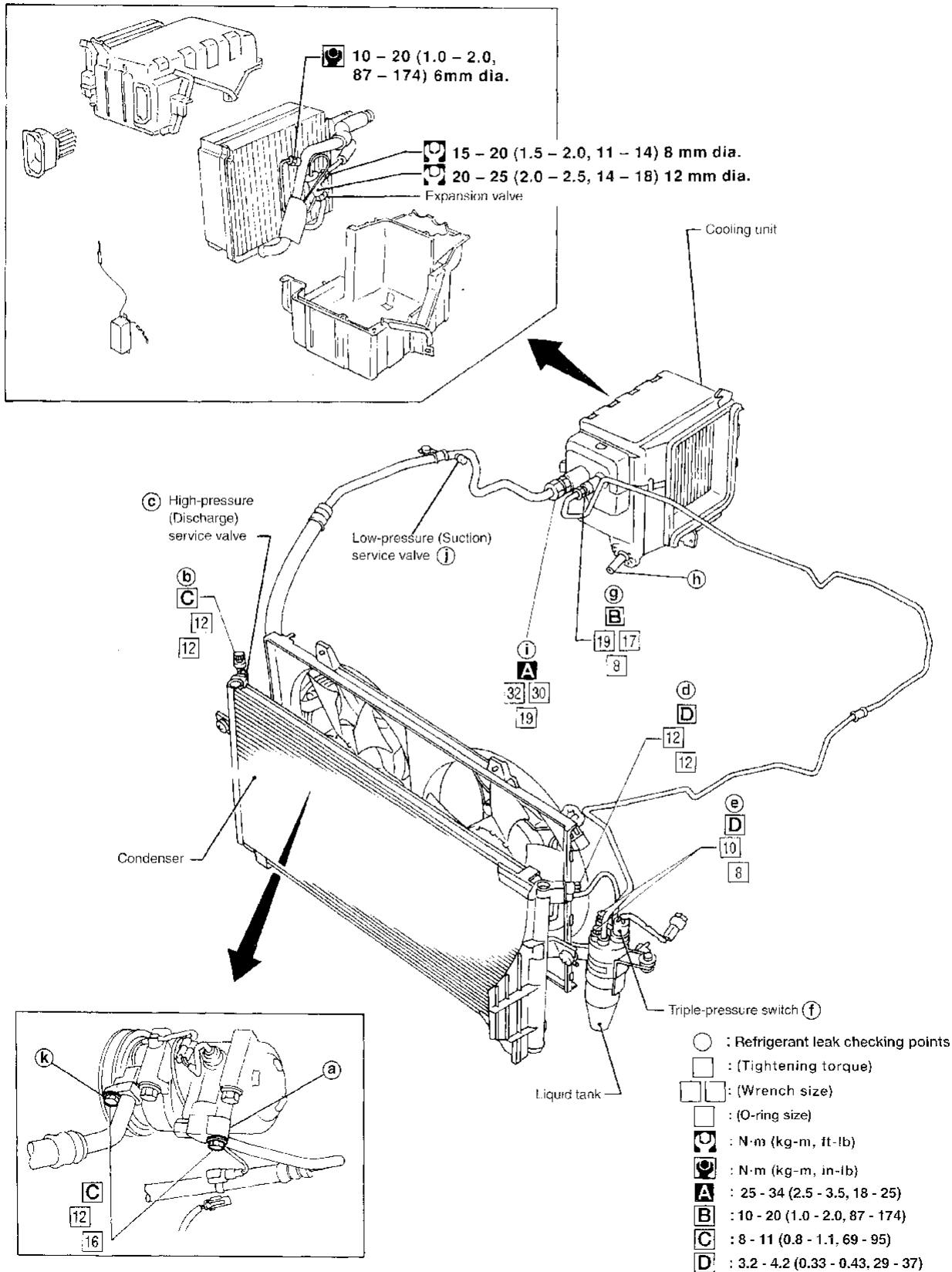

Compressor Mounting

SEC. 274-275

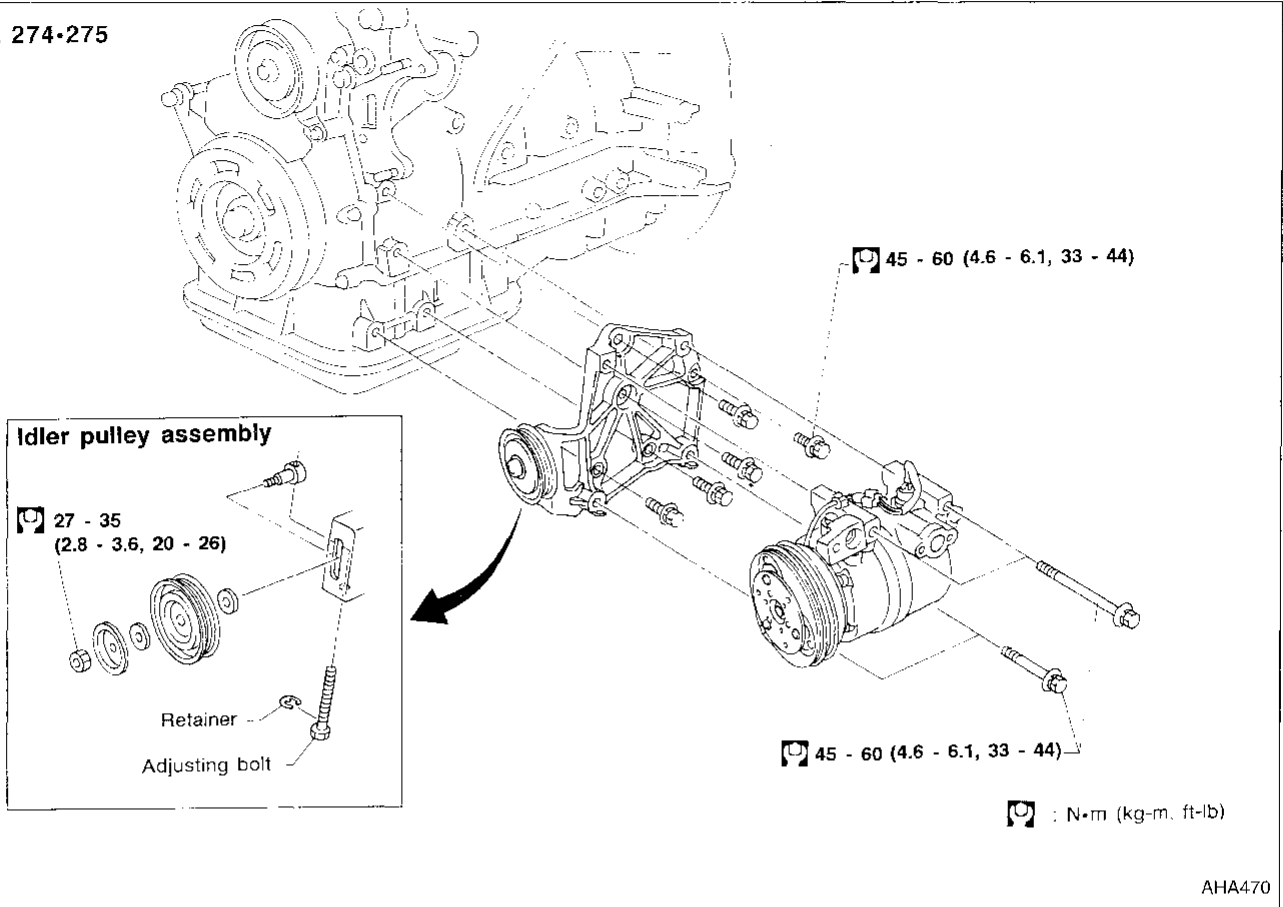

Belt Tension

- Refer to MA section (“Checking Drive Belts”, “ENGINE MAINTENANCE”).

Fast Idle Control Device (FICD)

- Refer to EC section (“IACV-FICD Solenoid Valve”, “TROUBLE DIAGNOSIS FOR NON-DETECTIVE ITEMS”).

GI
MA
EM
LC
EC
FE
CL
MT
AT
HA
RA
BR
SI
RS
BT
HA
EL
DX

Compressor

SEC. 274

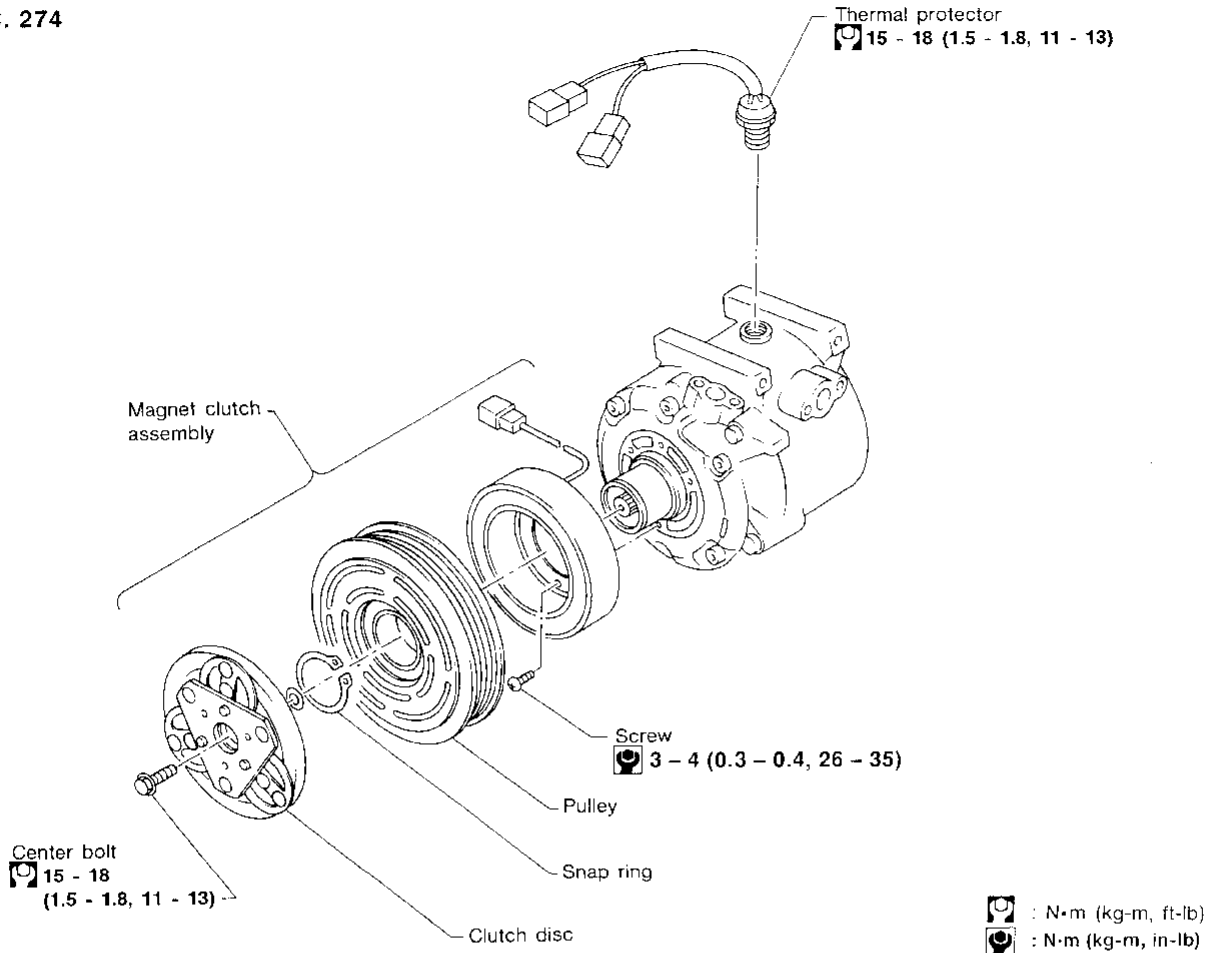

AHA471

Compressor Clutch

REMOVAL

- When removing center bolt, hold clutch disc with clutch disc wrench.

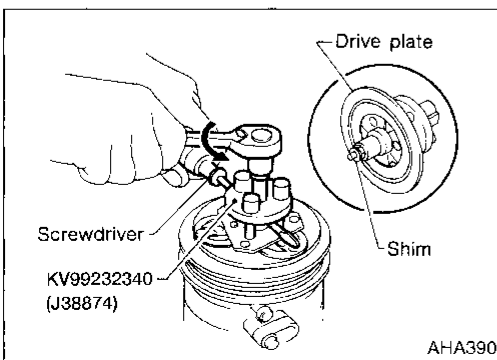
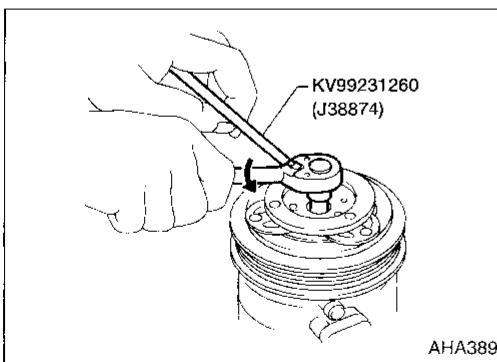

- Remove the drive plate using the clutch disc puller. Insert holder's three pins into the drive plate. Rotate the holder clockwise to hook it onto the plate. Then, tighten the center bolt to remove the drive plate. While tightening the center bolt, insert a round bar (screwdriver, etc.) between two of the pins (as shown in the figure) to prevent drive plate rotation. After removing the drive plate, remove the shims from either the drive shaft or the drive plate.

Compressor Clutch (Cont'd)

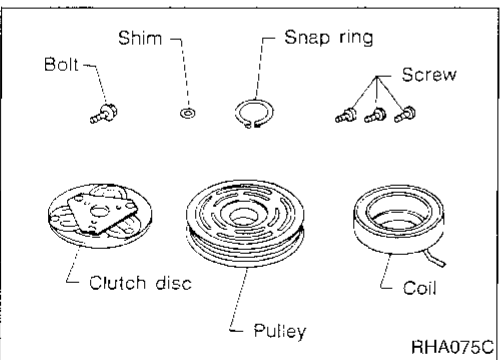
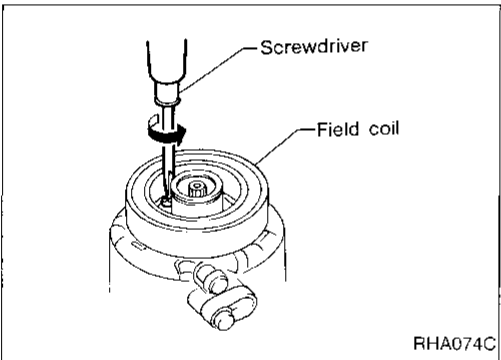
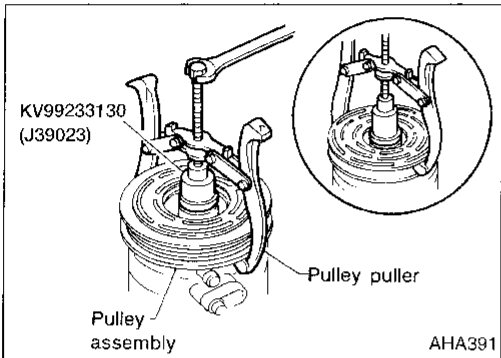
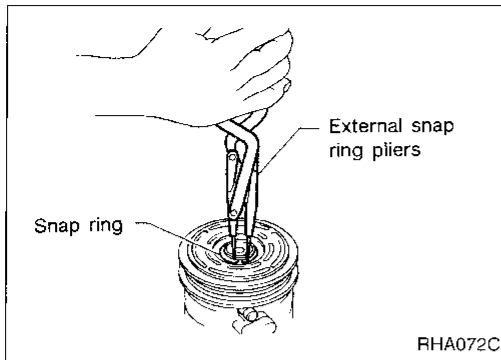

- Remove the snap ring using external snap ring pliers.

- Pulley removal**
Use a commercially available pulley puller. Position the center of the puller on the end of the drive shaft. Remove the pulley assembly with the puller.

For Pressed Pulleys:

To prevent deformation of the pulley groove, the pulley claws should be hooked under (not into) the pulley groove.

- Remove the field coil harness clip using a screwdriver.
- Remove the three field coil fixing screws and remove the field coil.

INSPECTION

Clutch disc

If the contact surface shows signs of damage due to excessive heat, replace clutch disc and pulley.

Pulley

Check the appearance of the pulley assembly. If contact surface of pulley shows signs of excessive grooving, replace clutch disc and pulley. The contact surfaces of the pulley assembly should be cleaned with a suitable solvent before reinstallation.

Coil

Check coil for loose connection or cracked insulation.

GI

MA

EM

LC

EC

FE

CL

MT

AT

FA

RA

BR

ST

RS

BT

HA

EL

IX

Compressor Clutch (Cont'd)

INSTALLATION

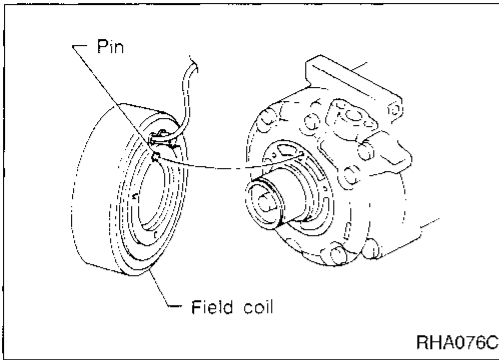

- Install the field coil.
- **Be sure to align the coil's pin with the hole in the compressor's front head.**
- Install the field coil harness clip using a screwdriver.

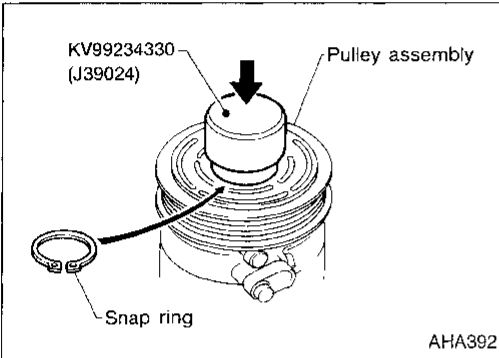

- Install the pulley assembly using the installer and a hand press, and then install the snap ring using snap ring pliers.

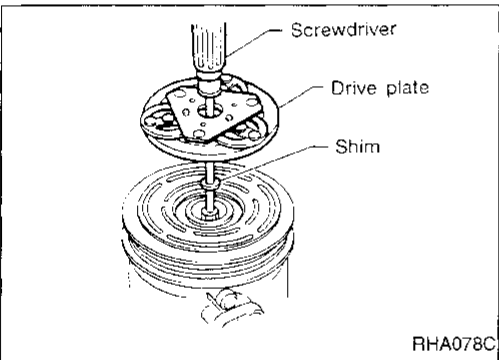

- Install the drive plate on the drive shaft, together with the original shim(s). Press the drive plate down by hand.

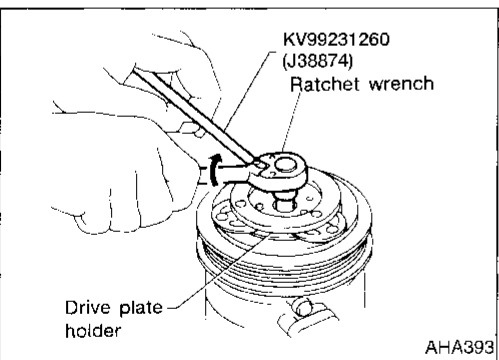

- Using the holder to prevent drive plate rotation, tighten the bolt to 12 to 15 N·m (1.2 to 1.5 kg·m, 9 to 11 ft·lb) torque.
- **After tightening the bolt, check that the pulley rotates smoothly.**

Compressor Clutch (Cont'd)

- Check clearance all the way around the clutch disc.

Disc-to-pulley clearance:

0.3 - 0.6 mm (0.012 - 0.024 in)

If the specified clearance is not obtained, replace adjusting spacer and recheck.

BREAK-IN OPERATION

When replacing compressor clutch assembly, always conduct the break-in operation. This is done by engaging and disengaging the clutch about thirty times. Break-in operation raises the level of transmitted torque.

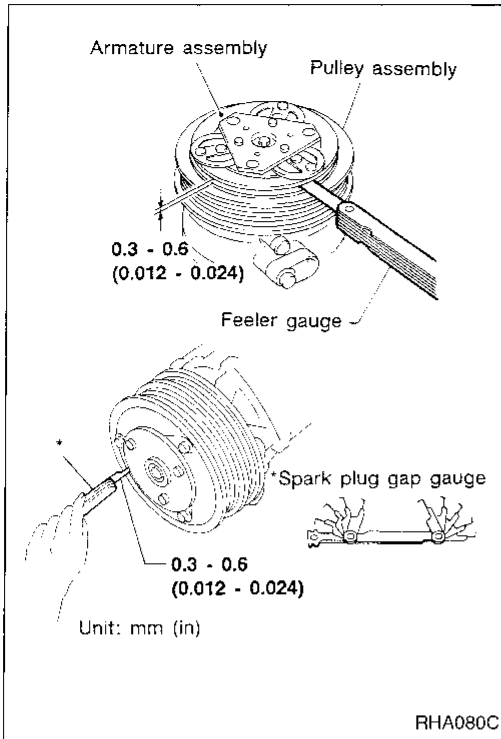

Thermal Protector

INSPECTION

- When servicing, do not allow foreign matter to get into compressor.
- Check continuity between two terminals.

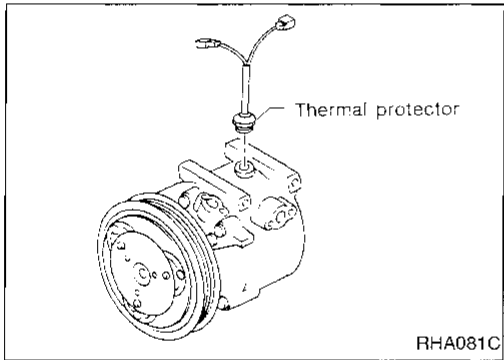

GI

HA

EM

LC

EC

FE

CL

MT

AT

FA

RA

BR

ST

RS

BT

HA

EL

IDX

General Specifications

COMPRESSOR

Model	DKV-14C
Type	Vane rotary
Displacement cm ³ (cu in)/Rev	140 (8.54)
Direction of rotation	Clockwise (Viewed from drive end)
Drive belt	Poly V type

LUBRICANT

Model	ZEXEL make DKV-14C
Name	Nissan A/C System Lubricant Type R
Part No.	KLH00-PAGR0
Capacity ml (US fl oz, Imp fl oz)	
Total in system	200 (6.8, 7.0)
Compressor (Service part) charging amount	200 (6.8, 7.0)

REFRIGERANT

Type	R-134a
Capacity kg (lb) g (oz)	0.70 - 0.80 (1.54 - 1.76) 700 - 800 (24.69 - 28.22)

Inspection and Adjustment

ENGINE IDLING SPEED

When A/C is ON

- Refer to EC section (“Inspection and Adjustment”, “SERVICE DATA AND SPECIFICATIONS”).

BELT TENSION

- Refer to MA section (“Checking Drive Belts”, “ENGINE MAINTENANCE”).

COMPRESSOR CLUTCH

Model	DKV-14C
Clutch disc-pulley clearance mm (in)	0.3 - 0.6 (0.012 - 0.024)