

ENGINE LUBRICATION & COOLING SYSTEMS

SECTION LC

GI
MA
EM
LC
EC
FE
CL
MT
AT
FA
RA
BR
ST
RS
BT
HA
EL
IDX

CONTENTS

PRECAUTIONS AND PREPARATION	2	Cooling Circuit.....	9
Supplemental Restraint System (SRS) “AIR BAG” and “SEAT BELT PRE-TENSIONER”	2	System Check.....	9
Liquid Gasket Application Procedure.....	2	Water Pump	11
Special Service Tools.....	3	Thermostat	13
ENGINE LUBRICATION SYSTEM	4	Radiator.....	14
Lubrication Circuit	4	Overheating Cause Analysis.....	15
Oil Pressure Check.....	5	SERVICE DATA AND SPECIFICATIONS (SDS)	16
Oil Pump	6	Engine Lubrication System	16
ENGINE COOLING SYSTEM	9	Engine Cooling System	16

PRECAUTIONS AND PREPARATION

Supplemental Restraint System (SRS) “AIR BAG” and “SEAT BELT PRE-TENSIONER”

The Supplemental Restraint System such as “AIR BAG” and “SEAT BELT PRE-TENSIONER” used along with a seat belt, helps to reduce the risk or severity of injury to the driver and front passenger for certain types of collision. The SRS composition which is available to NISSAN MODEL L30 is as follows (The composition varies according to the destination and optional equipment.):

- For a frontal collision
The Supplemental Restraint System consists of driver air bag module (located in the center of the steering wheel), front passenger air bag module (located on the instrument panel on passenger side), seat belt pre-tensioners, a diagnosis sensor unit, warning lamp, wiring harness and spiral cable.
- For a side collision
The Supplemental Restraint System consists of front side air bag module (located in the outer side of front seat), satellite sensor, diagnosis sensor unit (one of components of air bags for a frontal collision), wiring harness, warning lamp (one of components of air bags for a frontal collision).
Information necessary to service the system safely is included in the **RS section** of this service manual.

WARNING:

- To avoid rendering the SRS inoperative, which could increase the risk of personal injury or death in the event of a collision which would result in air bag inflation, all maintenance should be performed by an authorized NISSAN dealer. For removal of Spiral cable and Air Bag Module, see the RS section.
- Improper maintenance, including incorrect removal and installation of the SRS, can lead to personal injury caused by unintentional activation of the system.
- Do not use electrical test equipment on any circuit related to the SRS unless instructed to in this Service Manual. Spiral cable and wiring harnesses (except “SEAT BELT PRE-TENSIONER”) covered with yellow insulation either just before the harness connectors or for the complete harness are related to the SRS.

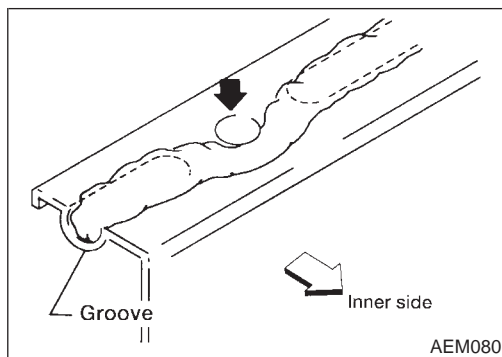
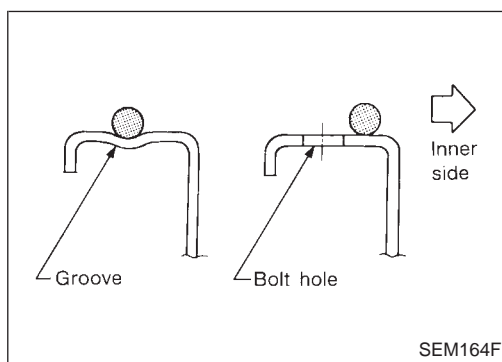

Liquid Gasket Application Procedure

- Use a scraper to remove all traces of old liquid gasket from mating surfaces and grooves. Also, completely clean any oil from these areas.
- Apply a continuous bead of liquid gasket to mating surfaces. (Use Genuine RTV silicone sealant Part No. 999MP-A7007 or equivalent.)
 - For oil pan, be sure liquid gasket diameter is 3.5 to 4.5 mm (0.138 to 0.177 in).
 - For areas except oil pan, be sure liquid gasket diameter is 2.0 to 3.0 mm (0.079 to 0.118 in).
- Apply liquid gasket around the inner side of bolt holes (unless otherwise specified).
- Assembly should be done within 5 minutes after coating.
- Wait at least 30 minutes before refilling engine oil and engine coolant.

PRECAUTIONS AND PREPARATION

Special Service Tools

The actual shapes of Kent-Moore tools may differ from those of special service tools illustrated here.

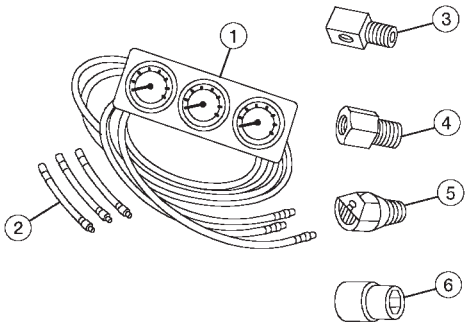
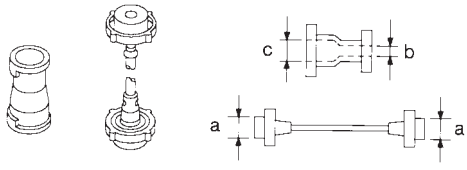
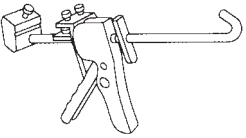
Tool number (Kent-Moore No.) Tool name	Description
(J34301-C) Oil pressure gauge set ① (J34301-1) Oil pressure gauge ② (J34301-2) Hoses ③ (J34298) Adapter ④ (J34282-1) Adapter ⑤ (790-301-1230-A) 60° adapter ⑥ (J34301-15) Square socket	 <p data-bbox="1047 388 1282 420">Measuring oil pressure</p> <p data-bbox="483 787 560 819">AAT896</p> <p data-bbox="1047 745 1356 808">Maximum measuring range: 1,379 kPa (14 kg/cm², 200 psi)</p>
EG17650301 (J33984-A) Radiator cap tester adapter	 <p data-bbox="1047 840 1485 903">Adapting radiator cap tester to radiator filler neck</p> <p data-bbox="483 1029 560 1060">NT564</p> <p data-bbox="1047 966 1307 1060">a: 28 mm (1.10 in) dia. b: 31.4 mm (1.236 in) dia. c: 41.3 mm (1.626 in) dia.</p>
WS39930000 (—) Tube presser	 <p data-bbox="1047 1081 1388 1113">Pressing the tube of liquid gasket</p> <p data-bbox="483 1249 560 1281">NT052</p>

GI

MA

EM

LC

EC

FE

CL

MT

AT

FA

RA

BR

ST

RS

BT

HA

EL

IDX

ENGINE LUBRICATION SYSTEM

Lubrication Circuit

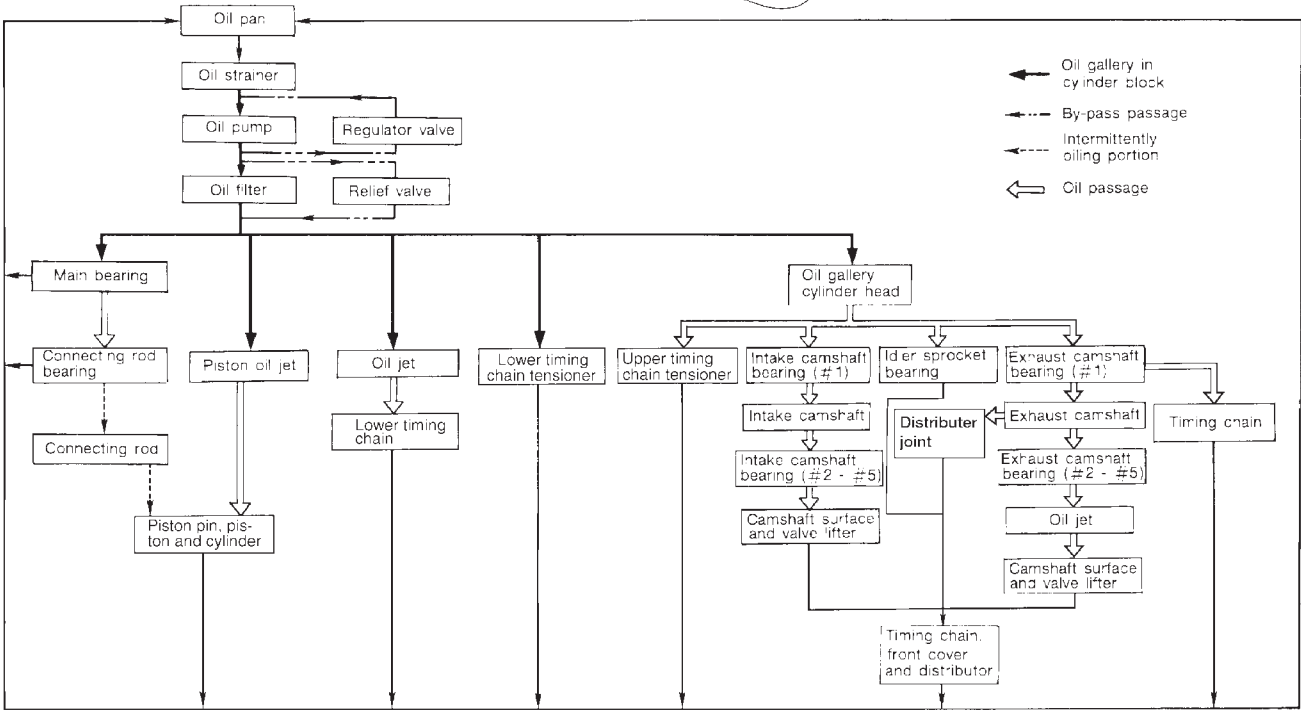
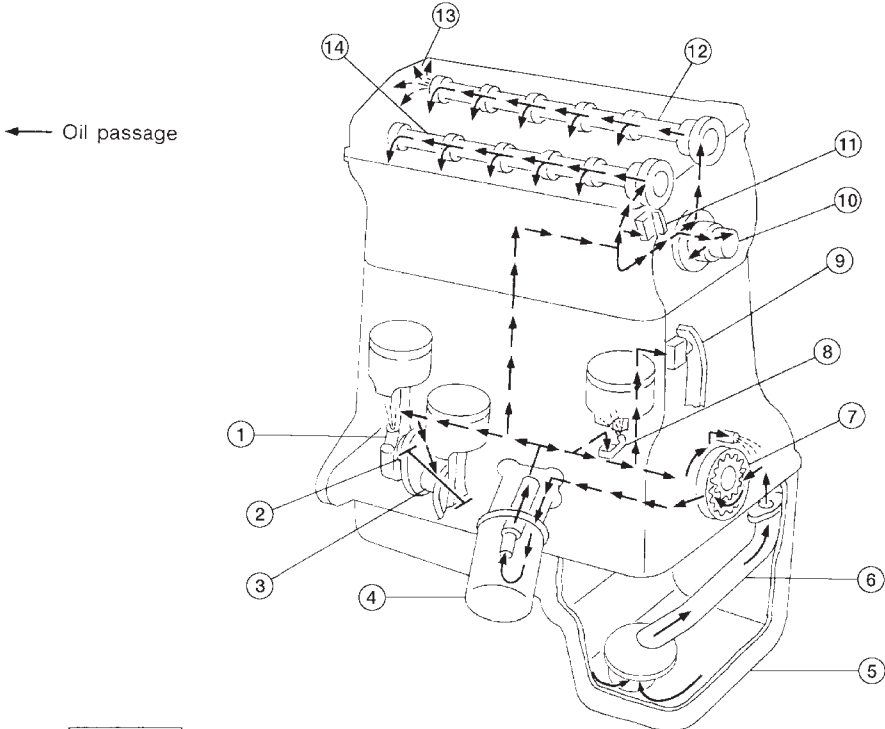

WLC001

- | | | |
|--------------------------|--------------------------------|--------------------------------|
| ① Connecting rod | ⑥ Oil strainer | ⑪ Upper timing chain tensioner |
| ② Connecting rod bearing | ⑦ Oil pump | ⑫ Exhaust camshaft |
| ③ Main bearing | ⑧ Piston oil jet | ⑬ Camshaft oil jet |
| ④ Oil filter | ⑨ Lower timing chain tensioner | ⑭ Intake camshaft |
| ⑤ Oil pan | ⑩ Idler sprocket | |

ENGINE LUBRICATION SYSTEM

Oil Pressure Check

WARNING:

- Be careful not to burn yourself, as the engine and oil may be hot.
- For M/T models, put gearshift lever in Neutral “N” position. For A/T models, put selector lever in Park “P” position.

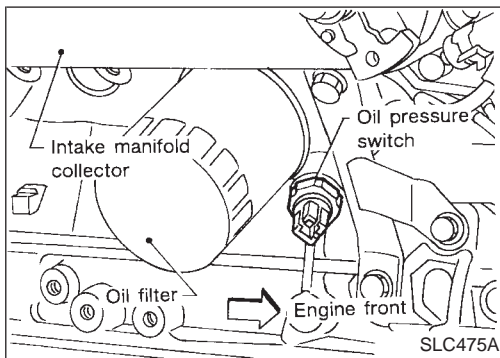

1. Check oil level.
2. Remove oil pressure switch.

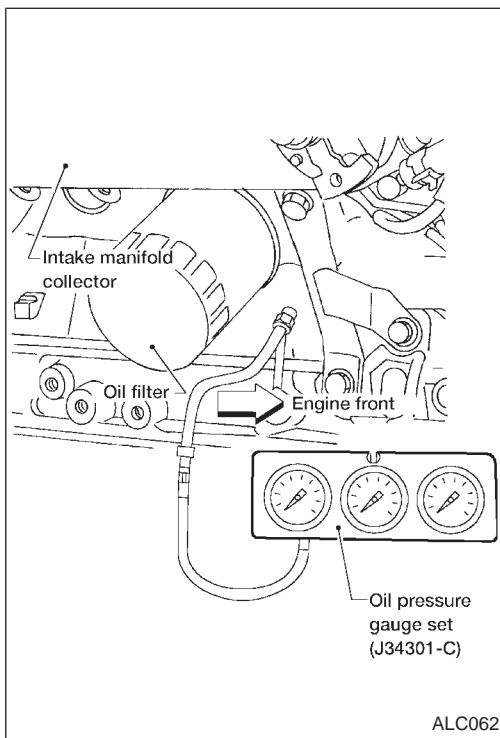

3. Install pressure gauge.
4. Start engine and warm it up to normal operating temperature.
5. Check oil pressure with engine running under no-load.

Engine speed rpm	Approximate discharge pressure kPa (kg/cm ² , psi)
Idle speed	More than 78 (0.8, 11)
3,000	412 - 481 (4.2 - 4.9, 60 - 70)

- If difference is extreme, check oil passage and oil pump for oil leaks.
6. Install oil pressure switch with sealant.

ENGINE LUBRICATION SYSTEM

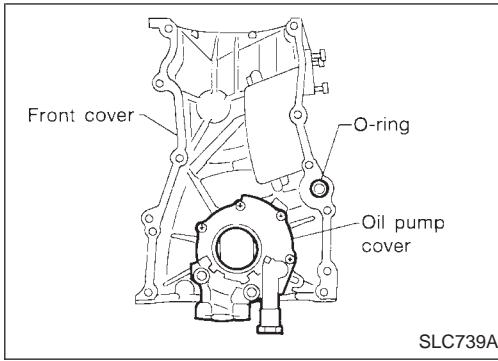

Oil Pump

REMOVAL

1. Remove front cover.
- Refer to EM-21 section (“Removal”, “TIMING CHAIN”).
2. Remove oil pump cover.

DISASSEMBLY AND ASSEMBLY

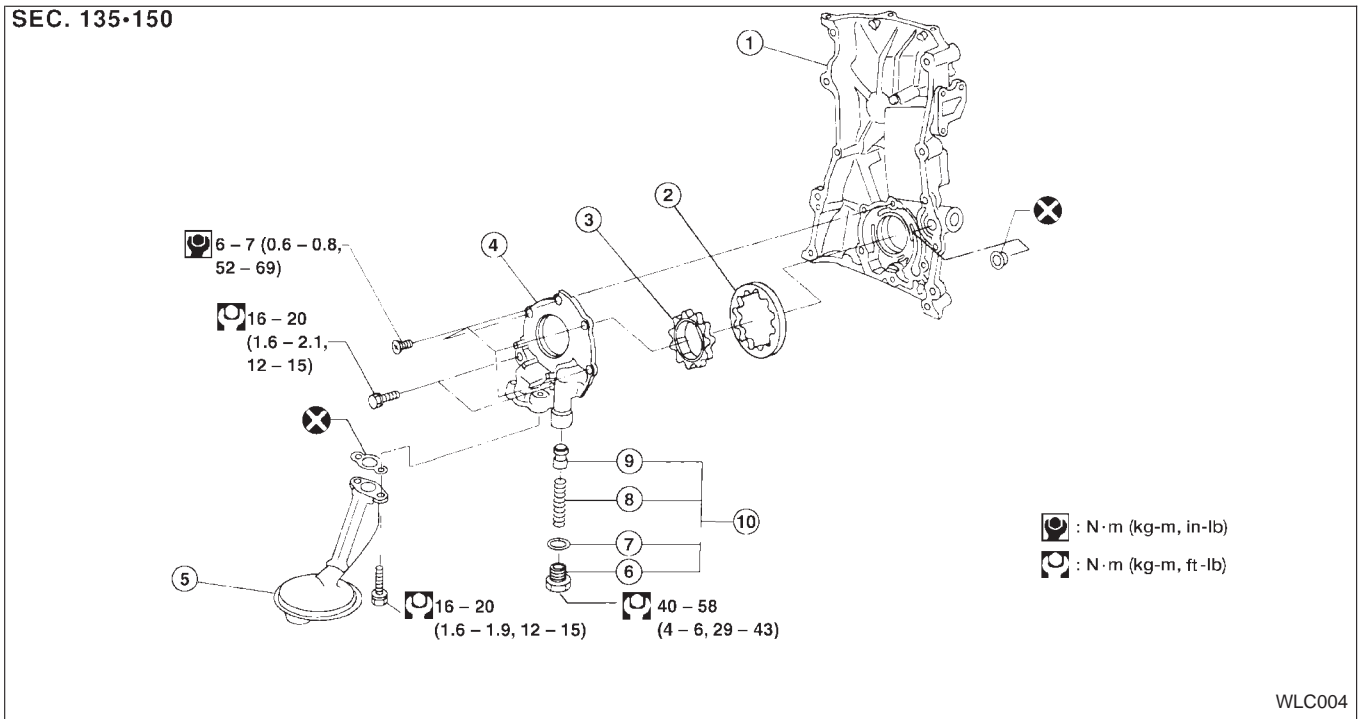

- ① Front cover
- ② Outer gear
- ③ Inner gear
- ④ Oil pump cover

- ⑤ Oil strainer
- ⑥ Cap
- ⑦ Washer

- ⑧ Spring
- ⑨ Regulator valve
- ⑩ Regulator valve assembly

ENGINE LUBRICATION SYSTEM

Oil Pump (Cont'd)

OIL PUMP INSPECTION

Using a feeler gauge, check the following clearances.

Standard clearance:

Unit: mm (in)

Body to outer gear radial clearance ①	0.114 - 0.260	(0.0045 - 0.0102)
Inner gear to outer gear tip clearance ②	less than 0.18	(0.0071)
Cover to inner gear clearance ③	0.05 - 0.09	(0.0020 - 0.0035)
Cover to outer gear axial clearance ④	0.03 - 0.19	(0.0012 - 0.0075)
Inner gear to brazed portion clearance ⑤	..	0.045 - 0.091	(0.0018 - 0.0036)

- If the tip clearance (②) exceeds the limit, replace gear set.
- If body to gear clearances (①, ③, ④, ⑤) exceed the limit, replace front cover assembly.

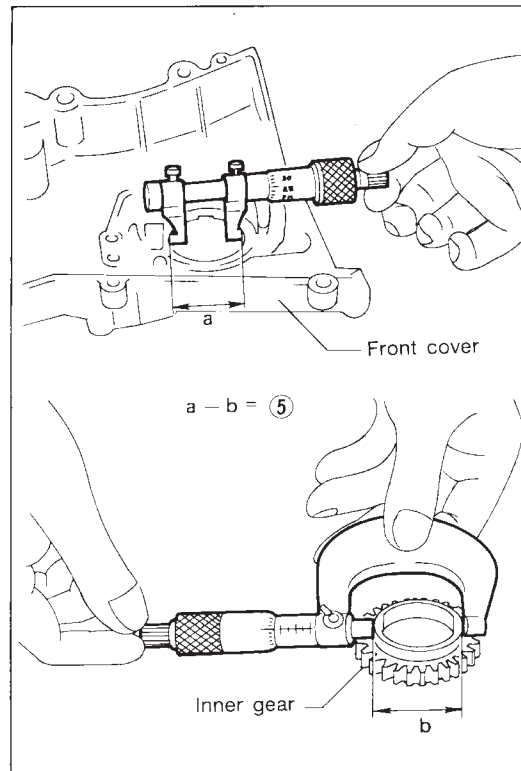
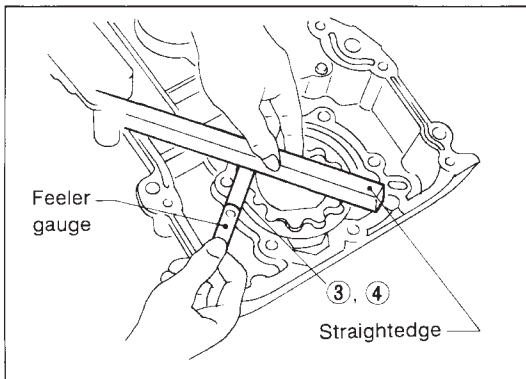
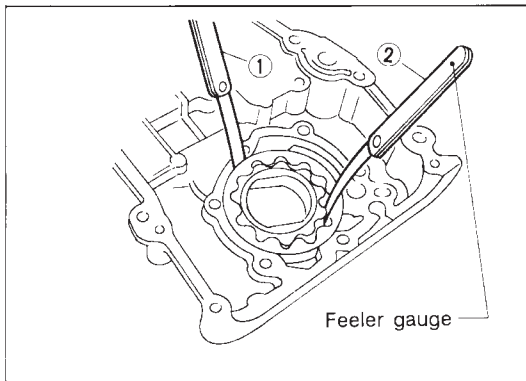

SLC741A

GI
MA
EM
LC
EC
FE
CL
MT
AT
FA
RA
BR
ST
RS
BT
HA
EL
IDX

ENGINE LUBRICATION SYSTEM

Oil Pump (Cont'd)

REGULATOR VALVE INSPECTION

1. Visually inspect components for wear and damage.
 2. Check oil pressure regulator valve sliding surface and valve spring.
 3. Coat regulator valve with engine oil. Check that it falls smoothly into the valve hole by its own weight.
- **Replace regulator valve set or oil pump assembly, if damaged.**

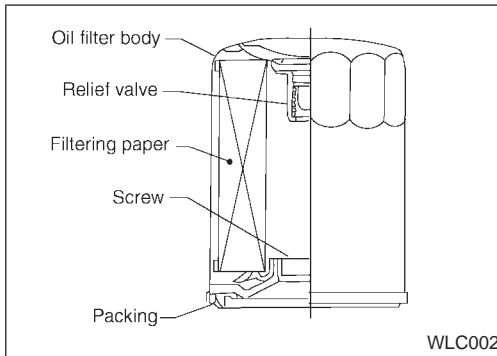
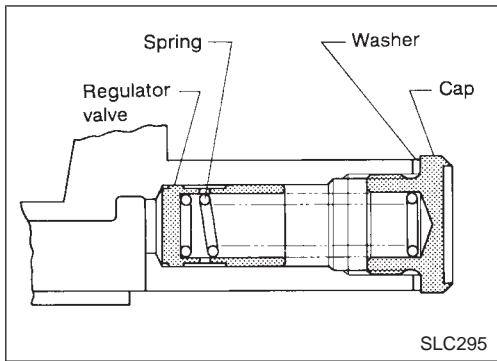

OIL FILTER

The oil filter is a small, full-flow cartridge type and is provided with a relief valve.

INSTALLATION

Install in the reverse order of removal.

- **Always replace oil seals and gaskets with new ones. Refer to EM-26 section ("OIL SEAL REPLACEMENT").**
- **When installing oil pump, apply engine oil to inner and outer gears.**
- **Use a scraper to remove old liquid gasket from mating surface of front cover.**
- **Also remove traces of liquid gasket from mating surface of cylinder block.**

ENGINE COOLING SYSTEM

Cooling Circuit

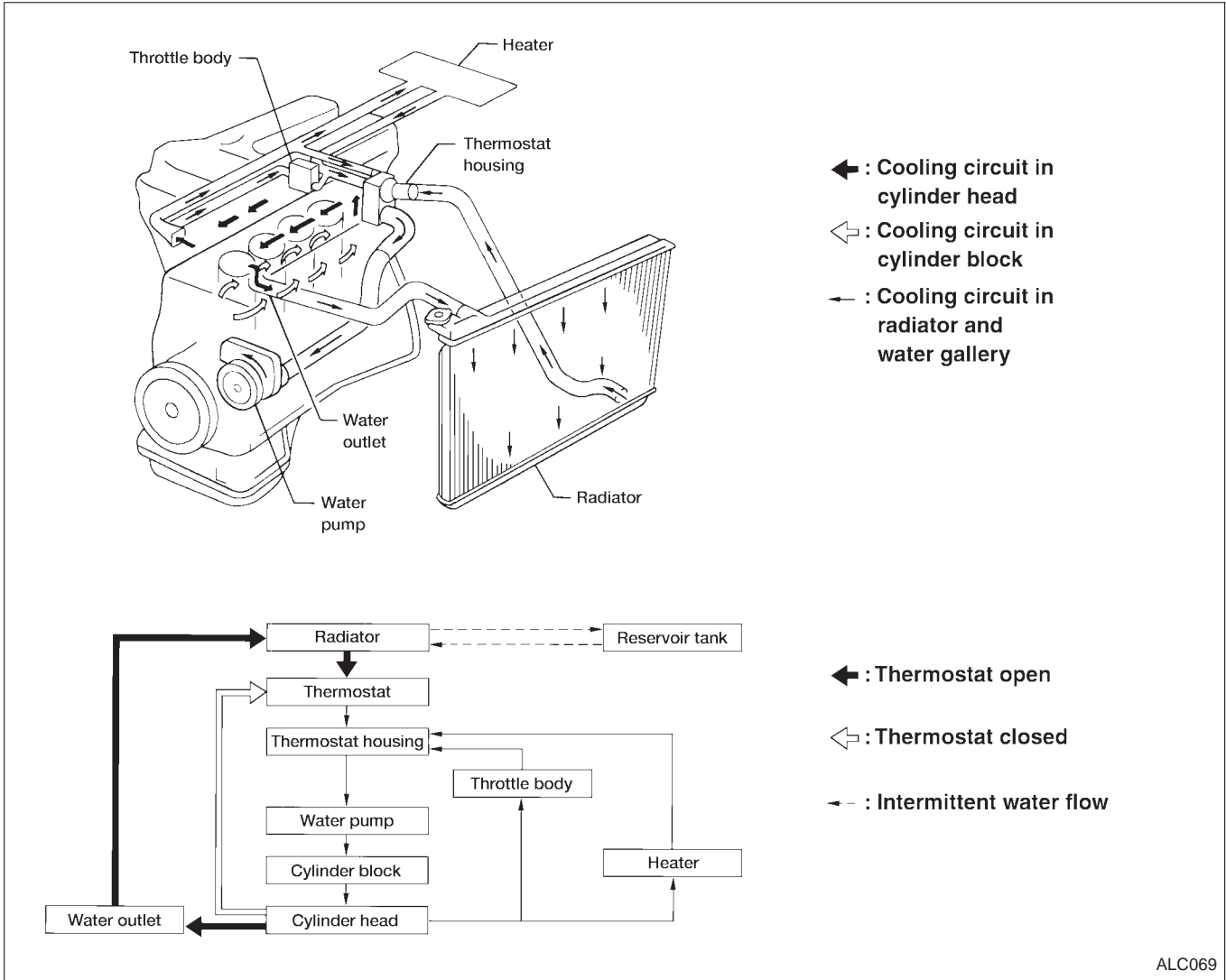

System Check

WARNING:

Never remove the radiator cap when the engine is hot. Serious burns could occur from high pressure coolant escaping from the radiator.

Wrap a thick cloth around the cap. Slowly turn it a quarter turn to allow built-up pressure to escape. Carefully remove the cap by turning it all the way.

CHECKING COOLING SYSTEM HOSES

Check hoses for the following:

- Improper attachment
- Leaks
- Cracks
- Damage
- Chafing
- Deterioration

CHECKING RADIATOR

Check radiator for mud or clogging. If necessary, clean radiator as follows.

- Be careful not to bend or damage the radiator fins.

GI
MA
EM
LC
EC
FE
CL
MT
AT
FA
RA
BR
ST
RS
BT
HA
EL
IDX

ENGINE COOLING SYSTEM

System Check (Cont'd)

- When radiator is cleaned without removal, remove all surrounding parts such as cooling fan, radiator shroud and horns. Then tape the harness and connectors to prevent water from entering.
1. Apply water by hose to the back side of the radiator core vertically downward.
 2. Apply water again to all radiator core surfaces once per minute.
 3. Stop washing if any stains no longer flow out from the radiator.
 4. Blow air into the back side of radiator core vertically downward.
- Use compressed air lower than 5 kg/cm² and keep distance more than 30 cm (11.8 in).
5. Blow air again into all the radiator core surfaces once per minute until no water sprays out.

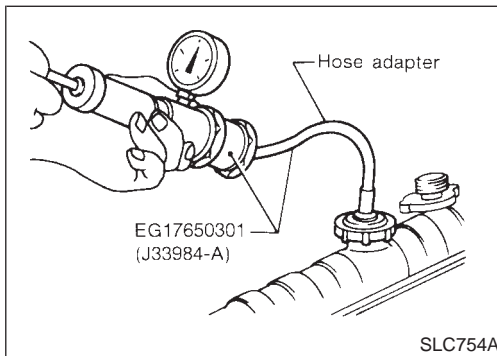

CHECKING COOLING SYSTEM FOR LEAKS

To check for leakage, apply pressure to the cooling system with a tester.

Testing pressure:

157 kPa (1.6 kg/cm², 23 psi)

CAUTION:

Higher pressure than specified may cause radiator damage.

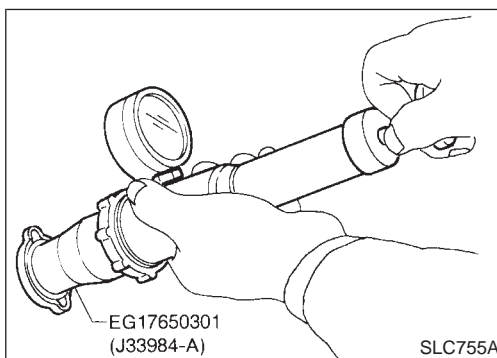

CHECKING RADIATOR CAP

To check radiator cap, apply pressure to cap with a tester.

Radiator cap relief pressure:

Standard

78 - 98 kPa (0.8 - 1.0 kg/cm², 11 - 14 psi)

Limit

59 - 98 kPa (0.6 - 1.0 kg/cm², 9 - 14 psi)

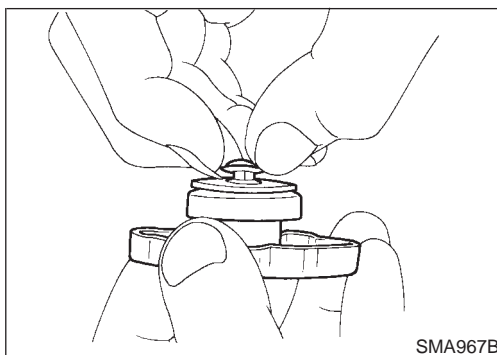

Pull the negative pressure valve to open it. Check that it closes completely when released.

ENGINE COOLING SYSTEM

Water Pump

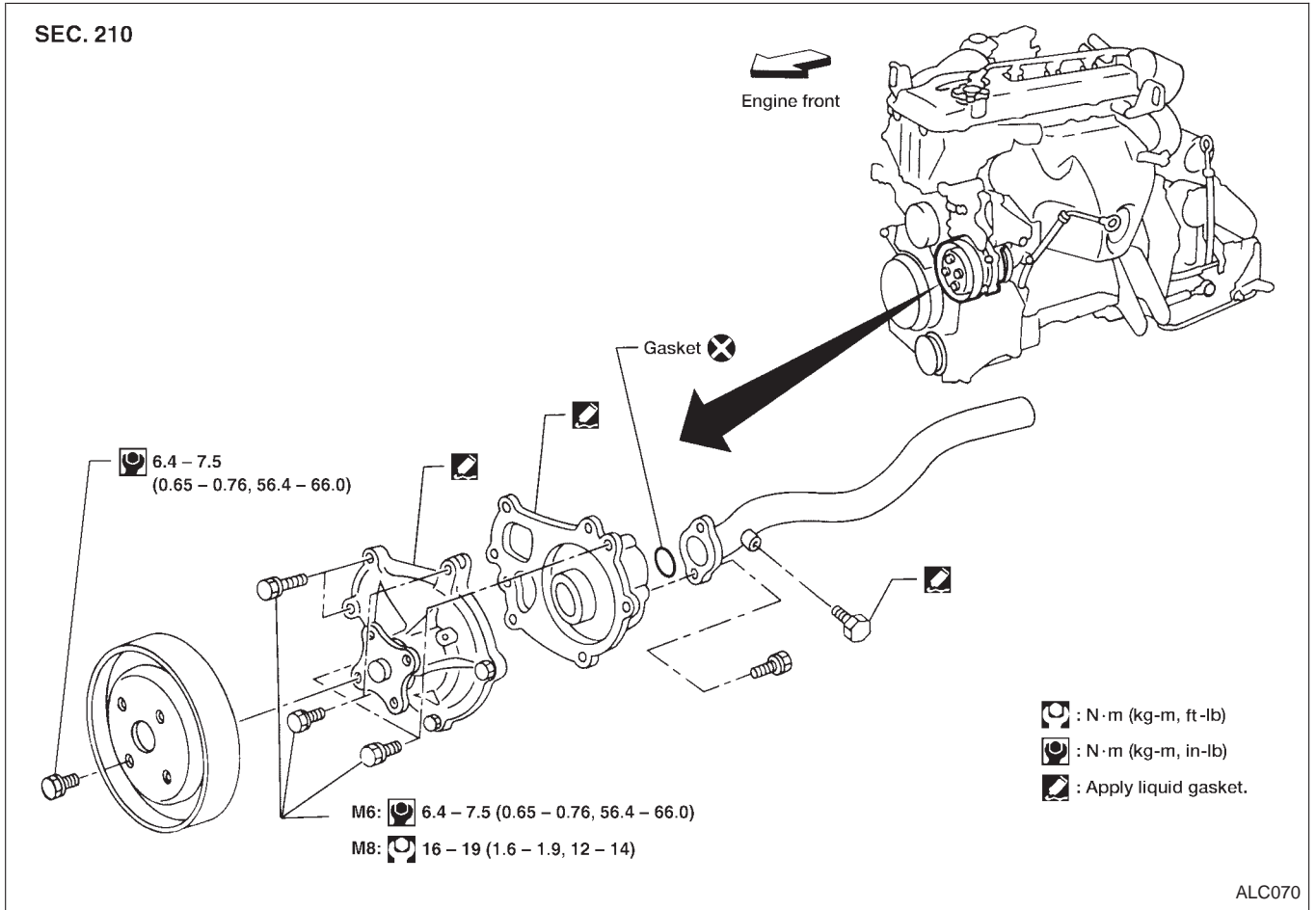

CAUTION:

- When removing water pump assembly, be careful not to get coolant on drive belt.
- Water pump cannot be disassembled and should be replaced as a unit.
- After installing water pump, connect hose and clamp securely, then check for leaks using radiator cap pressure tester.

GI
MA
EM
LC
EC
FE
CL
MT
AT
FA
RA
BR
ST
RS
BT
HA
EL
IDX

ENGINE COOLING SYSTEM

Water Pump (Cont'd)

REMOVAL

1. Drain coolant from drain plug on water pipe and radiator. Refer to MA-11 section ("Changing Engine Coolant").
2. Remove right lower splash cover.
3. Remove generator and air conditioner compressor.
4. Remove two bolts from coolant tube (rear of water pump).
5. Remove water pump assembly.

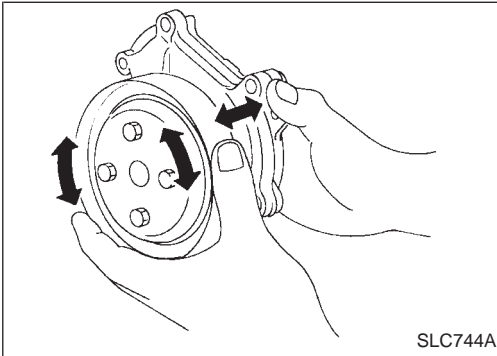
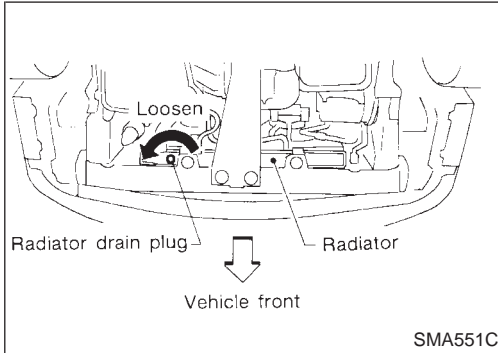
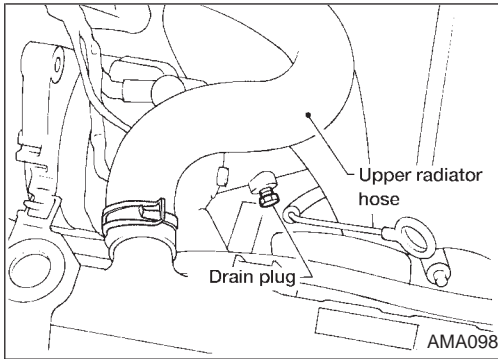

INSPECTION

- Check body assembly for rust or corrosion.
- Check for rough operation due to excessive end play.

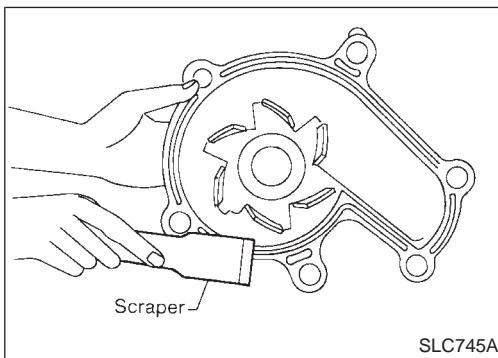

INSTALLATION

1. Use a scraper to remove old liquid gasket from water pump and water pump cover.
 - **Also remove traces of liquid gasket from mating surface of cylinder block.**

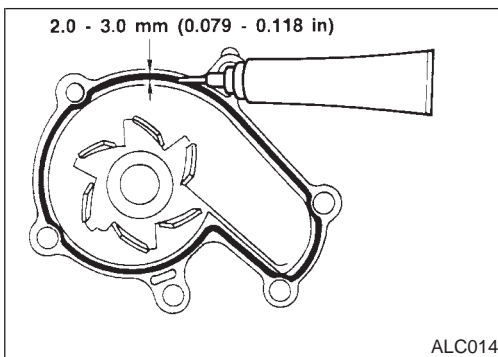

2. Apply a continuous bead of liquid gasket to mating surface of water pump and water pump cover (cylinder block side).
 - **Use Genuine RTV silicone sealant Part No. 999MP-A7007 or equivalent.**

When filling radiator with coolant, refer to MA-11 section ("Changing Engine Coolant", "ENGINE MAINTENANCE"). When installing drive belts, refer to MA-10 section ("Checking Drive Belts", "ENGINE MAINTENANCE").

ENGINE COOLING SYSTEM

Thermostat

SEC. 210

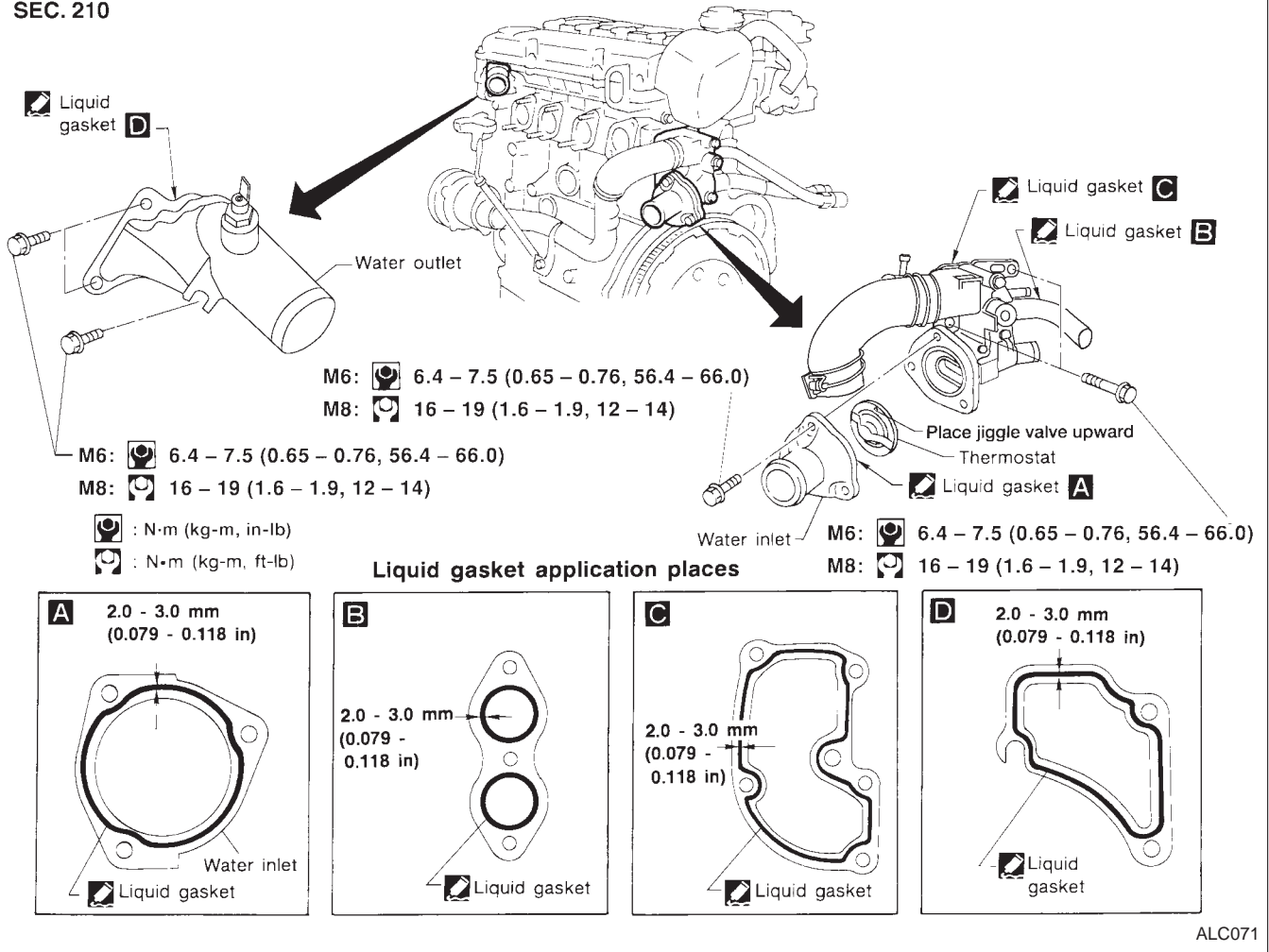

GI
 MA
 EM
LC
 EC
 FE
 CL
 MT
 AT
 FA
 RA
 BR
 ST
 RS
 BT
 HA
 EL
 IDX

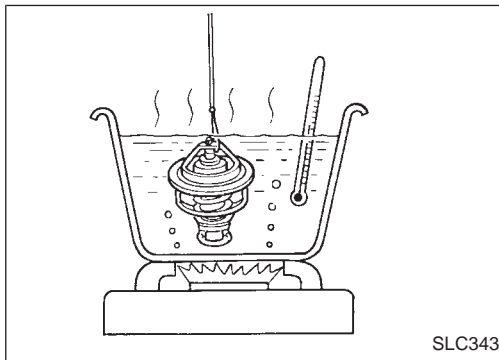

Be careful not to spill coolant over engine compartment. Use a rag to absorb coolant.

INSPECTION

1. Check valve seating condition at normal room temperatures. It should seat tightly.
2. Check valve opening temperature and valve lift.

		Standard
Valve opening temperature	°C (°F)	76.5 (170)
Valve lift	mm/°C (in/°F)	More than 8/90 (0.31/194)

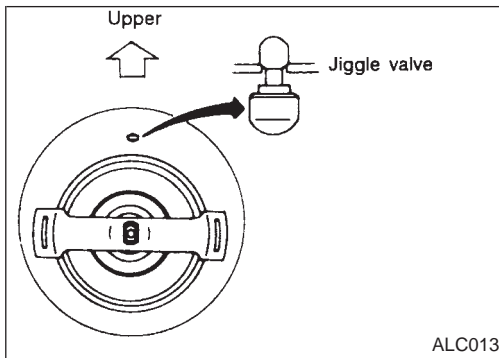

3. Then check if valve is closed at 5°C (9°F) below valve opening temperature.

INSTALLATION

Install thermostat with jiggle valve or air bleeder at upper side.

- Apply a continuous bead of liquid gasket to mating surface of water inlet.
- After installation, run engine for a few minutes, and check for leaks.

ENGINE COOLING SYSTEM

Radiator

SEC. 214

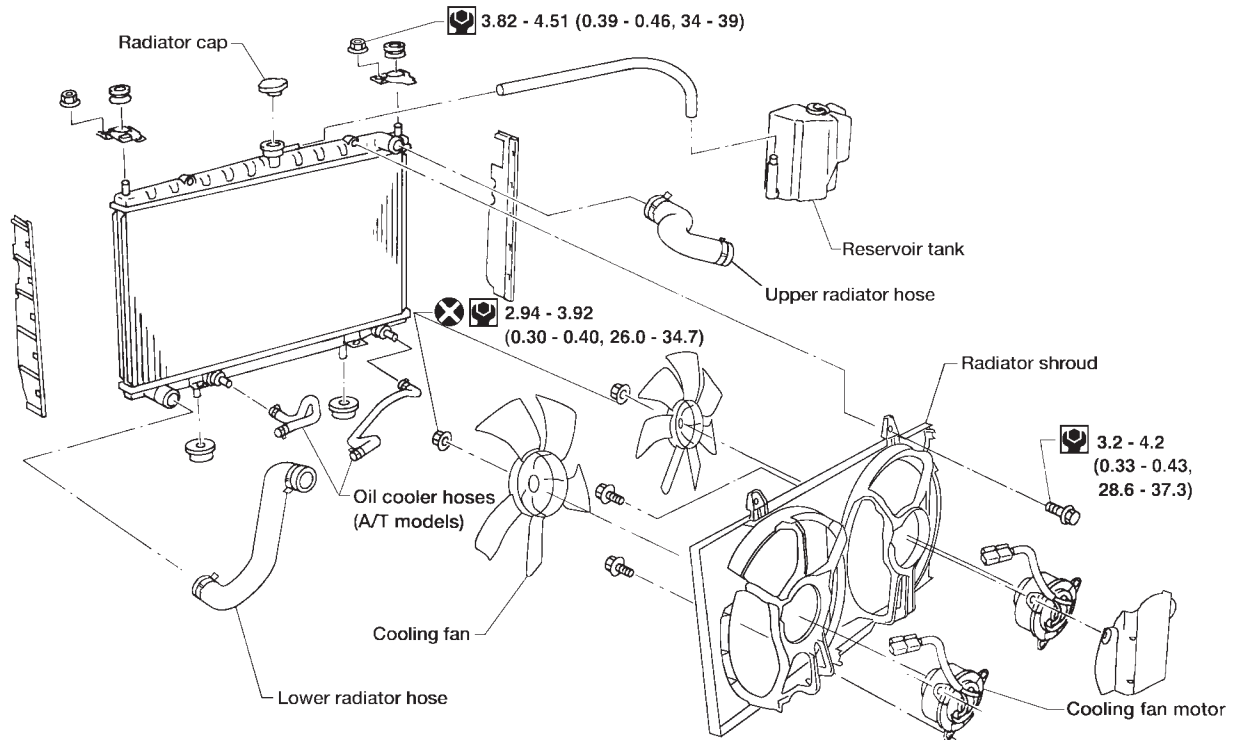

: N·m (kg-m, in-lb)

WLC003

Cooling fan control system

Cooling fans are controlled by the ECM.
For details, refer to EC-443 section ("Overheat", "TROUBLE DIAGNOSIS FOR OVERHEAT").

Refilling engine coolant

For details on refilling engine coolant, refer to MA-11 section ("Changing Engine Coolant").

ENGINE COOLING SYSTEM

Overheating Cause Analysis

		Symptom		Check items			
Cooling system parts malfunction	Poor heat transfer	Water pump malfunction	Worn or loose drive belt	—	—	GI	
		Thermostat stuck closed	—			MA	
		Damaged fins	Dust contamination or paper clogging			Mechanical damage	EM
			Excess foreign material (rust, dirt, sand, etc.)				LC
	Reduced air flow	Cooling fan does not operate	—	—	EC		
		High resistance to fan rotation			FE		
		Damaged fan blades			CL		
	Damaged radiator shroud	—	—	—	MT		
	Improper coolant mixture ratio	—	—	—	AT		
	Poor coolant quality	—	—	—	FA		
	Insufficient coolant	Coolant leaks	Cooling hose	Loose clamp	Poor sealing	RA	
				Cracked hose		BR	
			Water pump	Loose	Cracked radiator tank	ST	
			Radiator cap	Poor sealing		RS	
		Radiator	O-ring for damage, deterioration or improper fitting	Cracked radiator core	Cracked reservoir tank	BT	
Cracked radiator tank			HA				
Cracked radiator core			EL				
Overflowing reservoir tank	Exhaust gas leaks into cooling system	Cylinder head deterioration	Cylinder head gasket deterioration	IDX			
				RA			
Except cooling system parts malfunction	—	Overload on engine	Abusive driving	High engine rpm under no load	—	BR	
				Driving in low gear for extended time		ST	
				Driving at extremely high speed		RS	
			Powertrain system malfunction	BT			
			Installed improper size wheels and tires	HA			
	Blocked or restricted air flow	Blocked bumper	Blocked radiator grille	Draggng brakes	—	—	EL
				Improper ignition timing			HA
				Installed car brassiere			EL
				Mud contamination or paper clogging			HA
				Blocked radiator			EL
Blocked condenser	EL						
Installed large fog lamp	EL						

SERVICE DATA AND SPECIFICATIONS (SDS)

Engine Lubrication System

Oil pressure check

Engine speed	Approximate discharge pressure kPa (kg/cm ² , psi)
Idle speed	More than 78 (0.8, 11)
3,000 rpm	412 - 481 (4.2 - 4.9, 60 - 70)

Oil pump

Unit: mm (in)

Body to outer gear radial clearance	0.114 - 0.260 (0.0045 - 0.0102)
Inner gear to outer gear tip clearance	less than 0.18 (0.0071)
Cover to inner gear clearance	0.05 - 0.09 (0.0020 - 0.0035)
Cover to outer gear axial clearance	0.03 - 0.19 (0.0012 - 0.0075)
Inner gear to brazed portion clearance	0.045 - 0.091 (0.0018 - 0.0036)

Engine Cooling System

Thermostat

Valve opening temperature	°C (°F)	76.5 (170)
Valve lift	mm/°C (in/°F)	More than 8/90 (0.31/194)

Radiator

Unit: kPa (kg/cm², psi)

Cap relief pressure		
Standard		78 - 98 (0.8 - 1.0, 11 - 14)
Limit		59 - 98 (0.6 - 1.0, 9 - 14)
Leakage test pressure		157 (1.6, 23)