

RESTRAINT SYSTEM

SECTION RS

CONTENTS

PRECAUTION2	Installation — Front Passenger Air Bag Module 23
Supplemental Restraint System (SRS) “Air Bag” And “Seat Belt Pre-Tensioner” 2	Installation — Side Air Bag Module..... 24
SEAT BELTS3	Disposal of Air Bag Module and Seat Belt Pre-tensioner 24
Precaution for Seat Belt Service 3	Deployment of Side Air Bag Module (Built-in type) (Outside of vehicle)..... 27
After A Collision.....3	Deployment Procedures For Seat Belt Pre-Tensioner (Outside of Vehicle) 28
Front Seat Belt.....4	TROUBLE DIAGNOSES — Supplemental Restraint System (SRS) 31
Rear Seat Belt6	Trouble Diagnoses Introduction..... 31
Seat Belt Inspection.....8	How to Perform Trouble Diagnoses for Quick and Accurate Repair 33
SUPPLEMENTAL RESTRAINT SYSTEM (SRS) 11	Schematic 35
Precautions for SRS “AIR BAG” and “SEAT BELT PRE-TENSIONER” Service 11	Wiring Diagram — SRS — 36
Special Service Tools..... 11	Self-diagnosis..... 40
Description 12	Trouble Diagnoses for Air Bag Warning Lamp..... 60
Seat Belt Pre-tensioner with Load Limiter..... 12	Trouble Diagnosis for Seat Belt Pre-tensioner Warning Lamp..... 62
Built-in Type Side Air Bag..... 13	COLLISION DIAGNOSIS 64
SRS Component Parts Location..... 13	For Side Collision 66
Maintenance Items..... 14	SRS Inspection (For side collision)..... 66
Removal and Installation — Diagnosis Sensor Unit, Seat Belt Pre-tensioner and Satellite Sensor..... 16	
Removal — Air Bag Module and Spiral Cable 18	
Removal — Front Passenger Air Bag Module 19	
Removal — Side Air Bag Module.....21	
Installation — Air Bag Module and Spiral Cable..... 22	

When you read wiring diagrams:

- Read GI section, “HOW TO READ WIRING DIAGRAMS”.
 - See EL section, “POWER SUPPLY ROUTING” for power distribution circuit.
- When you perform trouble diagnoses, read GI section, “HOW TO FOLLOW FLOW CHART IN TROUBLE DIAGNOSES” and “HOW TO PERFORM EFFICIENT DIAGNOSIS FOR AN ELECTRICAL INCIDENT”.**

GI
MA
EM
LC
EC
FE
CL
MT
AT
FA
RA
BR
ST
RS
BT
HA
EL
IDX

PRECAUTION

SUPPLEMENTAL RESTRAINT SYSTEM (SRS) “AIR BAG” AND “SEAT BELT PRE-TENSIONER”

The Supplemental Restraint System such as “AIR BAG” and “SEAT BELT PRE-TENSIONER” used along with a seat belt, helps to reduce the risk or severity of injury to the driver and front passenger for certain types of collision. The SRS composition which is available to NISSAN MODEL L30 is as follows:

- For a frontal collision
The Supplemental Restraint System consists of driver air bag module (located in the center of the steering wheel), front passenger air bag module (located on the instrument panel on passenger side), seat belt pre-tensioners, a diagnosis sensor unit, warning lamp, wiring harness and spiral cable.
- For a side collision
The Supplemental Restraint System consists of side air bag module (located in the outer side of front seat), satellite sensor, diagnosis sensor unit (one of components of air bags for a frontal collision), wiring harness, warning lamp (one of components of air bags for a frontal collision).

WARNING:

- **To avoid rendering the SRS inoperative, which could increase the risk of personal injury or death in the event of a collision which would result in air bag inflation, all maintenance must be performed by an authorized NISSAN dealer.**
- **Improper maintenance, including incorrect removal and installation of the SRS, can lead to personal injury caused by unintentional activation of the system.**
- **Do not use electrical test equipment on any circuit related to the SRS unless instructed to in this Service Manual. Spiral cable and wiring harnesses (except “SEAT BELT PRE-TENSIONER”) covered with yellow insulation either just before the harness connectors or for the complete harness are related to the SRS.**

SEAT BELTS

Precaution for Seat Belt Service

CAUTION:

- Before removing the seat belt pre-tensioner assembly, turn the ignition switch off, disconnect both battery cables and wait at least 3 minutes. GI
- Do not use electrical test equipment for seat belt pre-tensioner connector.
- After replacing or reinstalling seat belt pre-tensioner assembly, or reconnecting seat belt pre-tensioner connector, check the system function. Refer to “Self-diagnosis” (RS-40) for details. MA
- Do not use disassemble buckle or seat belt assembly. EM
- Replace anchor bolts if they are deformed or worn out. LC
- Never oil tongue and buckle. EC
- If any component of seat belt assembly is questionable, do not repair. Replace the whole seat belt assembly. FE
- If webbing is cut, frayed, or damaged, replace seat belt assembly. CL
- When replacing seat belt assembly, use a genuine seat belt assembly. MT

After A Collision

WARNING:

Inspect all seat belt assemblies including retractors and attaching hardware after any collision. NISSAN recommends that all seat belt assemblies in use during a collision be replaced unless the collision was minor and the belts show no damage and continue to operate properly. Failure to do so could result in serious personal injury in an accident. Seat belt assemblies not in use during a collision should also be replaced if either damage or improper operation is noted. Seat belt pre-tensioner should be replaced even if the seat belts are not in use during a frontal collision in which the air bags are deployed. AT

Replace any seat belt assembly if:

- The seat belt was in use at the time of a collision (except for minor collisions and the belts, retractors and buckles show no damage and continue to operate properly). FA
- The seat belt was damaged in an accident. (i.e. torn webbing, bent retractor or guide, etc.) RA
- The seat belt attaching point was damaged in an accident. Inspect the seat belt attaching area for damage or distortion and repair as necessary before installing a new seat belt assembly. BR
- Anchor bolts are deformed or worn out. ST
- The seat belt pre-tensioner should be replaced even if the seat belts are not in use during the collision in which the air bags are deployed. RS

RS

BT

HA

EL

IDX

SEAT BELTS

Front Seat Belt

REMOVAL AND INSTALLATION

Remove front seat. Refer to BT-35 section (“Front Seat”, “SEAT”).

- ① Remove buckle.
Remove front and rear inner kick plates.
- ② Remove belt anchor bolts.
Remove center pillar lower garnish.
- ③ Remove adjuster cover and upper guide loop anchor bolt.
- ④ Remove center pillar upper garnish.
- ⑤ Remove two adjuster bolts and adjuster assembly. **A**
- ⑥ Disconnect seat belt pre-tensioner connector.
- ⑦ Remove seat belt pre-tensioner retractor bolt and screw.
- ⑧ Remove seat belt pre-tensioner retractor.

SEAT BELTS

Front Seat Belt (Cont'd)

SEC. 868

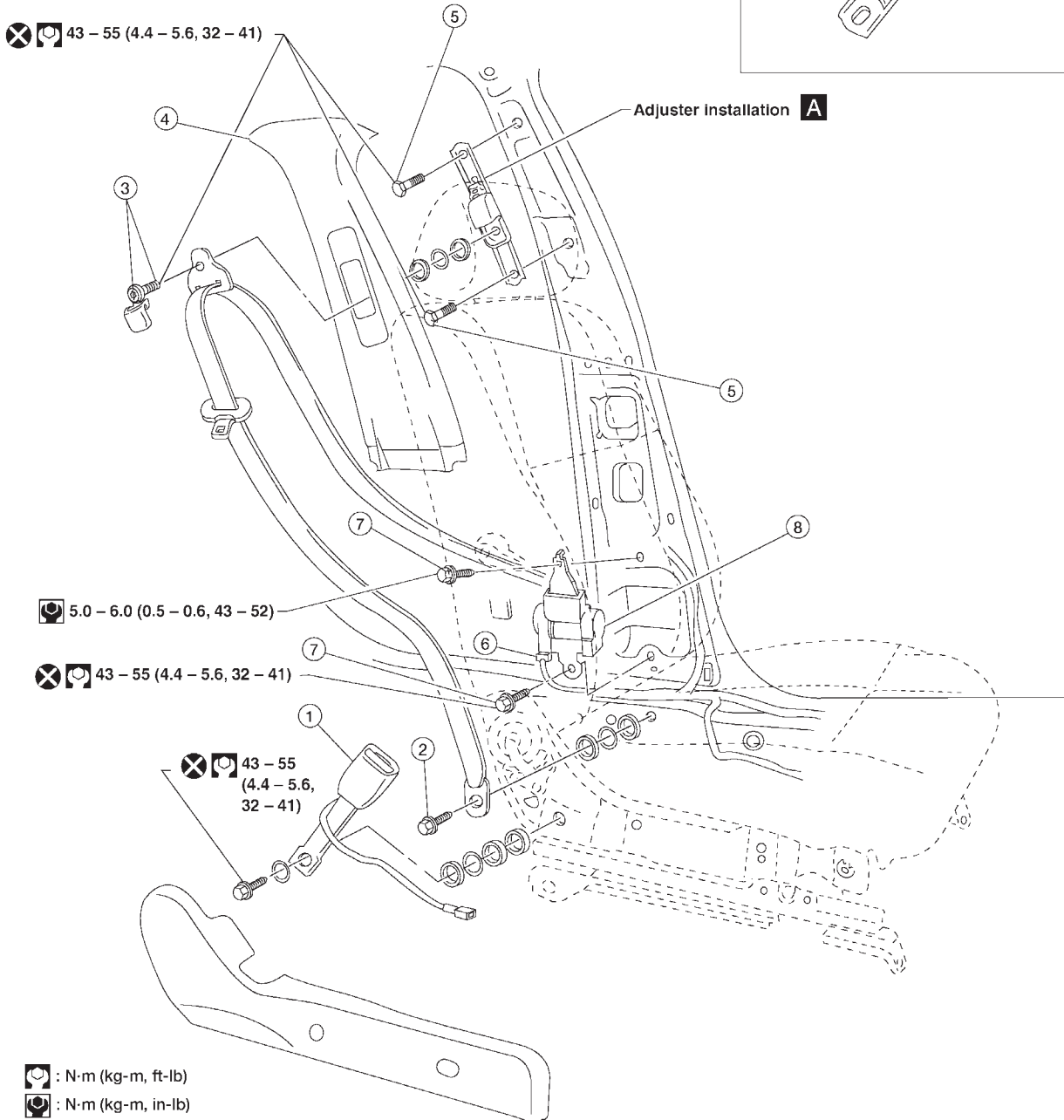
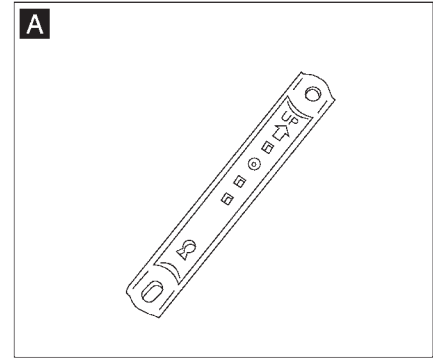

GI
 MA
 EM
 LC
 EC
 FE
 CL
 MT
 AT
 FA
 RA
 BR
 ST
RS
 BT
 HA
 EL
 IDX

WRS010

SEAT BELTS

Rear Seat Belt

REMOVAL AND INSTALLATION

- ① Remove rear seat. Refer to "SEAT" in BT-34 section for details.
- ② Remove outer and floor anchor bolt. **A B**
- ③ Remove rear side garnish. Refer to "SIDE AND FLOOR TRIM" in BT-21 section for details.
- ④ Remove rear parcel shelf finisher. Refer to "SIDE AND FLOOR TRIM" in BT-21 section for details.
- ⑤ Remove bolts securing rear seat belt retractor, then remove seat belt and seat belt retractor. **C D**

SEC. 869

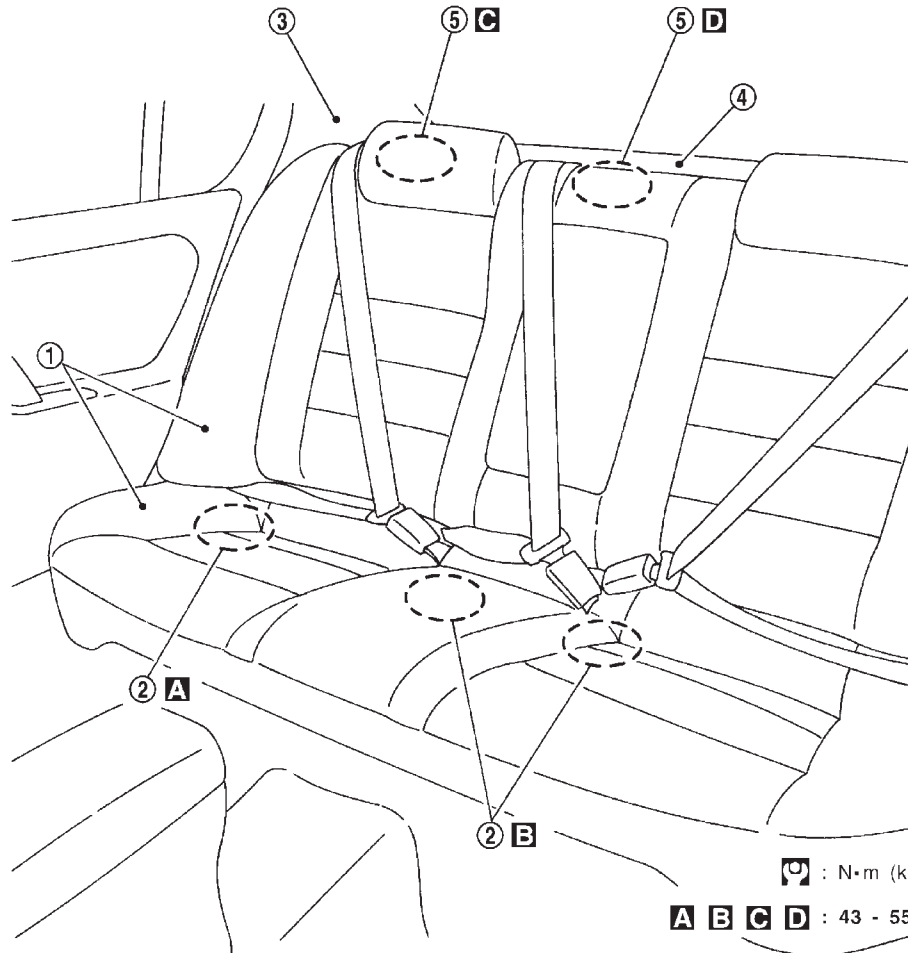

SRS558

SEAT BELTS

Rear Seat Belt (Cont'd)

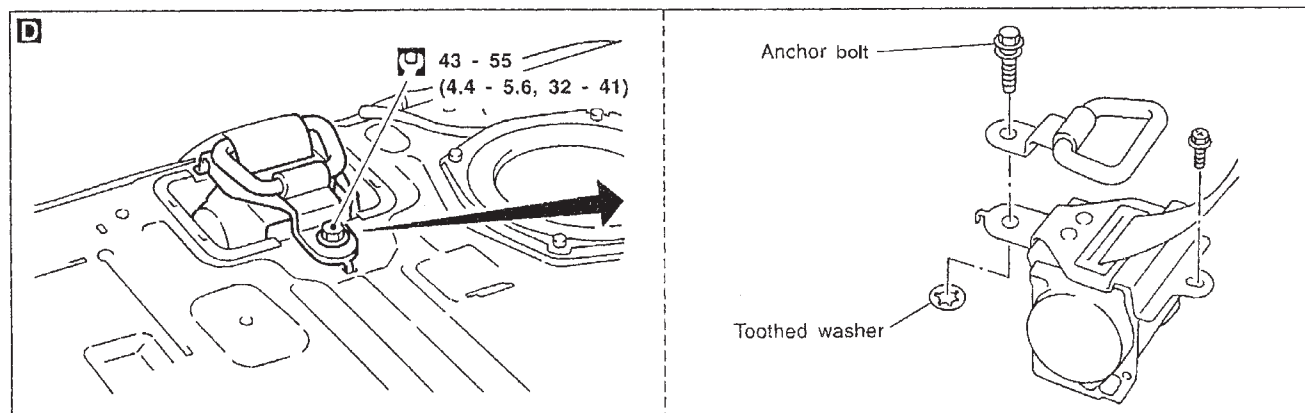
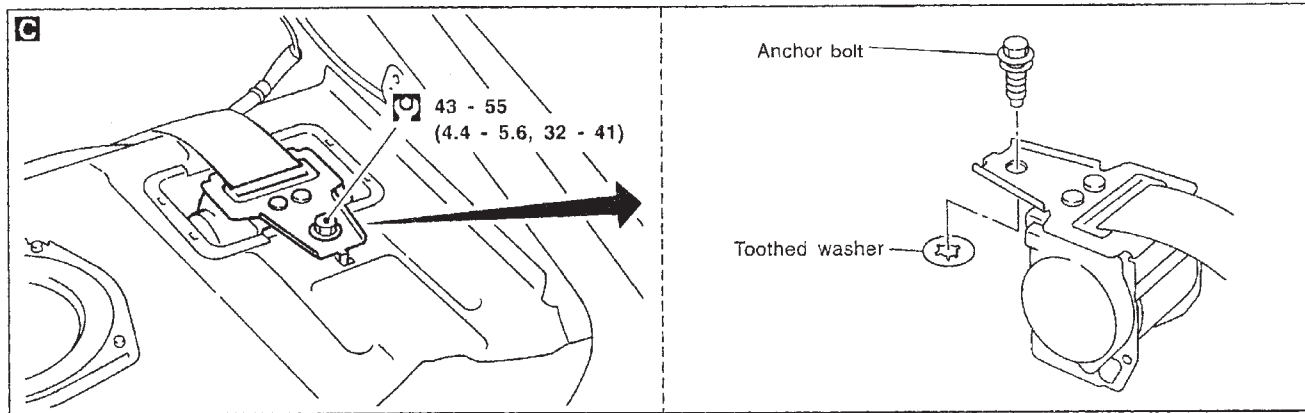
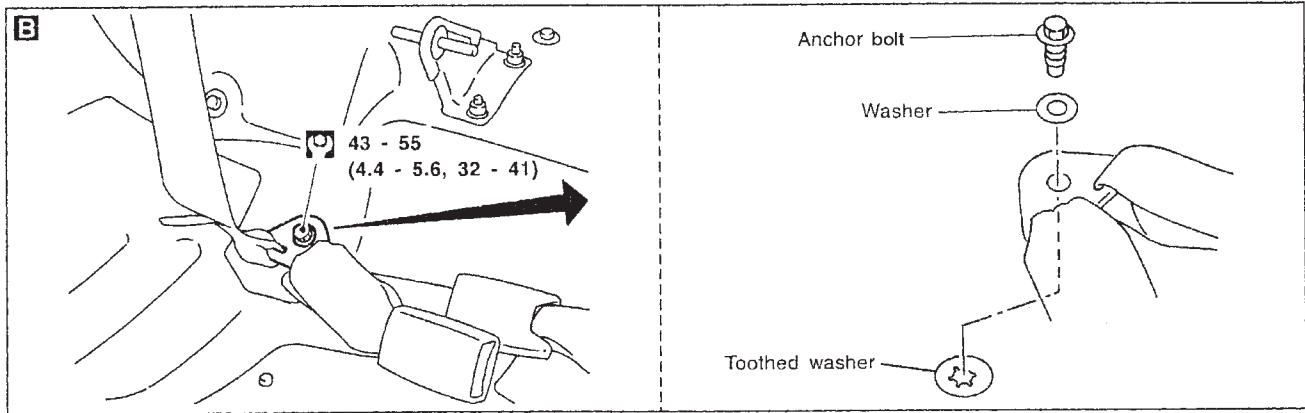
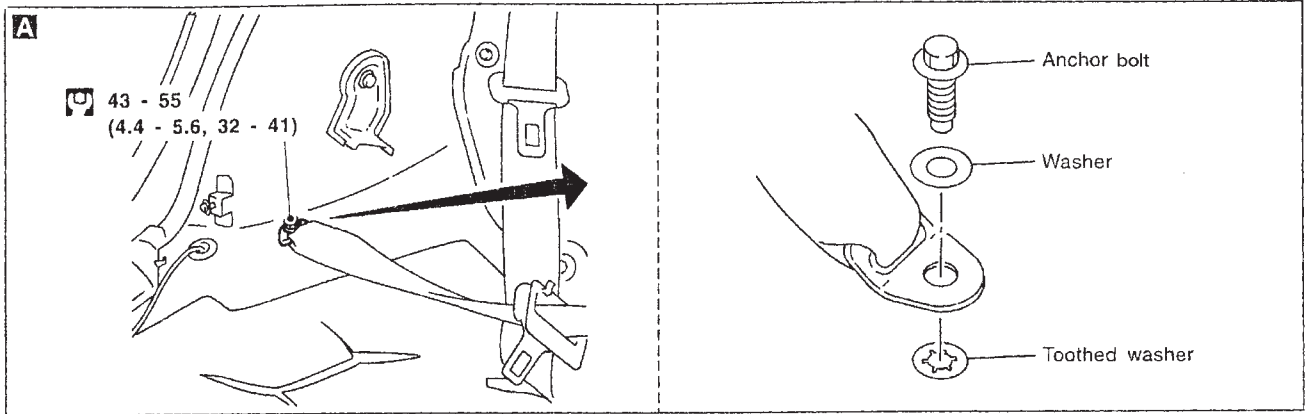

GI
MA
EM
LC
EC
FE
CL
MT
AT
FA
RA
BR
ST
RS
BT
HA
EL
IDX

SEAT BELTS

Seat Belt Inspection

AFTER A COLLISION

WARNING:

Inspect all seat belt assemblies including retractors and attaching hardware after any collision. NISSAN recommends that all seat belt assemblies in use during a collision be replaced unless the collision was minor and the belts show no damage and continue to operate properly. Failure to do so could result in serious personal injury in an accident. Seat belt assemblies not in use during a collision should also be replaced if either damage or improper operation is noted. Seat belt pre-tensioner should be replaced even if the seat belts are not in use during a frontal collision in which the air bags are deployed.

Replace any seat belt assembly if:

- The seat belt was in use at the time of a collision (except for minor collisions and the belts, retractors and buckles show no damage and continue to operate properly).
- The seat belt was damaged in an accident (i.e. torn webbing, bent retractor or guide, etc.).
- The seat belt attaching point was damaged in an accident. Inspect the seat belt attaching area for damage or distortion and repair as necessary before installing a new seat belt assembly.
- Anchor bolts are deformed or worn out.
- The seat belt pre-tensioner should be replaced even if the seat belts are not in use during the collision in which the air bags are deployed.

PRELIMINARY CHECKS

1. Check the seat belt warning lamp/chime for proper operation as follows:
 - a. Switch ignition ON. The seat belt warning lamp should illuminate. Also, the seat belt warning chime should sound for about seven seconds.
 - b. Fasten driver's seat belt. The seat belt warning lamp should go out and the chime (if sounding) should stop.
 - c. If the seat belt warning lamp is blinking, conduct self-diagnosis using CONSULT-II, and seat belt warning lamp. Refer to "Self-diagnosis", "TROUBLE DIAGNOSES — Supplemental Restraint System (SRS)", RS-40.
2. Check that the seat belt retractor, seat belt anchor and buckle bolts are securely attached.
3. Check the shoulder seat belt guide and shoulder belt height adjuster for front seats. Ensure guide swivels freely and that belt lays flat and does not bind in guide. Ensure height adjuster operates properly and holds securely.

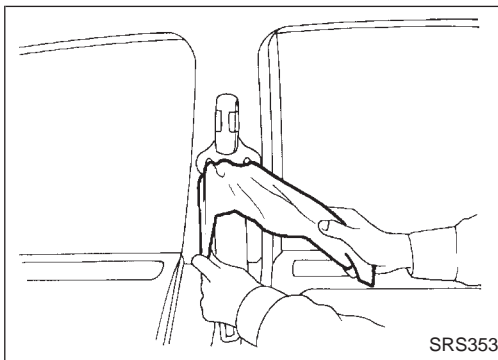

4. Check retractor operation:
 - a. Fully extend the seat belt webbing and check for twists, tears or other damage.
 - b. Allow the seat belt to retract. Ensure that belt returns smoothly and completely into the retractor. If the seat belt does not return smoothly, wipe the inside of the loops with a clean paper cloth etc. because dirt built up in the loops of the upper anchors can cause the seat belts to retract slowly.
 - c. Fasten the seat belt. Pull firmly on belt and buckle to ensure belt remains latched. Unfasten seat belt. Ensure belt releases freely and buckle button returns to original position.
5. Repeat steps above as necessary to check the other seat belts.

SEAT BELTS

Seat Belt Inspection (Cont'd)

ON-VEHICLE CHECK SEAT BELT RETRACTOR

Emergency Locking Retractors (ELR) and Automatic Locking Retractors (ALR)

NOTE:

All seat belt retractors are of the Emergency Locking Retractors (ELR) type. In an emergency (sudden stop) the retractor will lock and prevent the belt from extending any further. All 3-point type seat belt retractors except the driver's seat belt also have an Automatic Locking Retractors (ALR) mode. The ALR mode (also called child restraint mode) is used when installing child seats. The ALR mode is activated when the seat belt is fully extended. When the belt is then retracted partially, the ALR mode automatically locks the seat belt in a specific position so the belt cannot be extended any further. To cancel the ALR mode, allow the seat belt to fully wind back into the retractor.

Check the seat belt retractors using the following test(s) to determine if a retractor assembly is operating properly.

ELR function stationary check

Grasp the shoulder belt and pull forward quickly. The retractor should lock and prevent the belt from extending further.

ALR function stationary check

1. Pull out entire length of seat belt from retractor until a click is heard.
2. Retract the belt partially. A clicking noise should be heard as the belt retracts indicating retractor is in the Automatic Locking Retractors (ALR) mode.
3. Grasp the seat belt and try to pull out of retractor. Belt must lock and not extend further. If NG, replace the retractor assembly.
4. Allow the entire length of belt to retract to cancel the ALR mode.

ELR function moving check

WARNING:

Perform the following test in a safe, open area clear of other vehicles and obstructions (for example, a large, empty parking lot). Road surface must be paved and dry. DO NOT perform the following test on wet or gravel roads or on public streets and highways. This could result in an accident and serious personal injury. The driver and passenger must be prepared to brace themselves in the event the retractor does not lock.

1. Fasten driver's seat belt. Buckle a passenger into the seat for the belt.
2. Proceed to the designated safe area.
3. Drive the vehicle at approximately 16 km/h (10 MPH). Notify any passengers of the pending sudden stop and the driver and passenger must be prepared to brace themselves in the event the retractor does not lock. Apply brakes firmly and make a very hard stop.

During the stop, seat belts should lock and not extend. If the seat belt retractor assembly does not lock, perform the retractor off-vehicle check.

GI

MA

EM

LC

EC

FE

CL

MT

AT

FA

RA

BR

ST

RS

BT

HA

EL

IDX

SEAT BELTS

Seat Belt Inspection (Cont'd)

OFF-VEHICLE CHECK SEAT BELT RETRACTOR

1. Remove the seat belt retractor assembly.
2. Slowly pull out belt while tilting the retractor assembly forward from the mounted position without twisting the retractor assembly as shown in the illustration.

15 degrees or less tilt: Belt can be pulled out.

35 degrees or more tilt: Belt locks and cannot be pulled out.

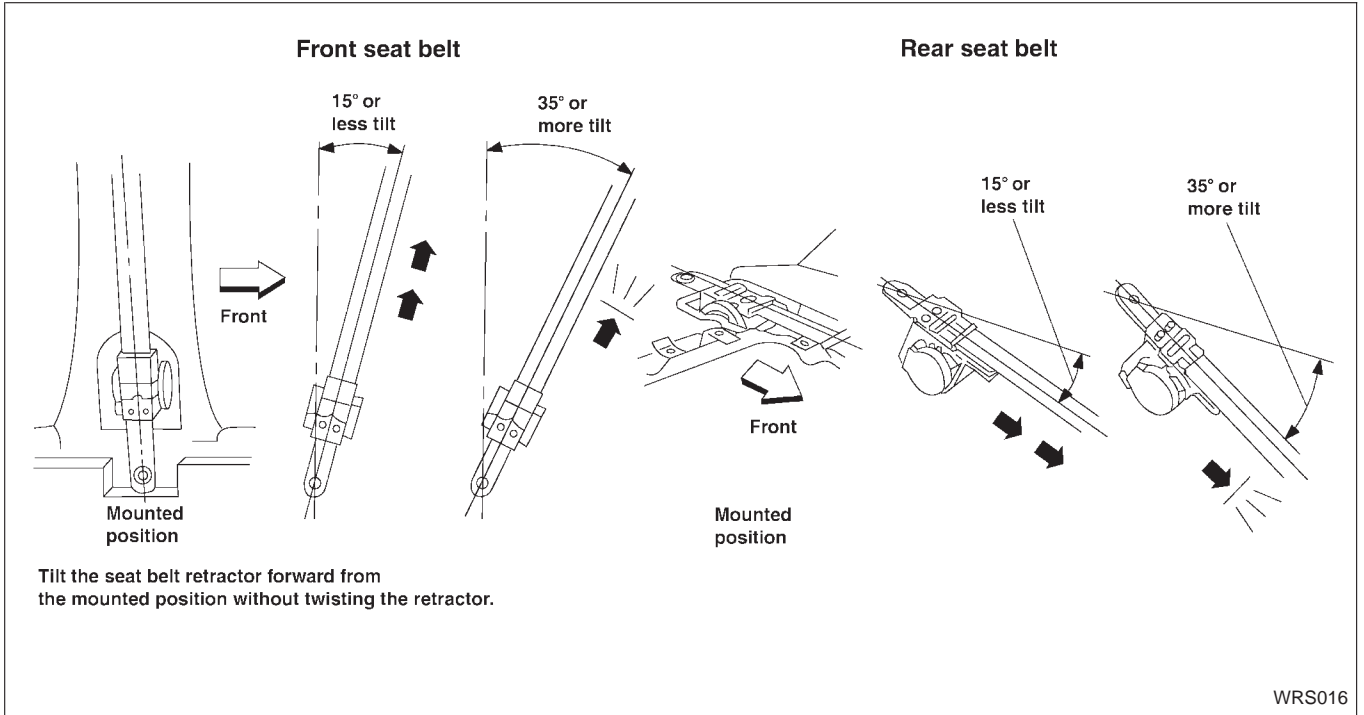

If NG, replace the retractor assembly.

SUPPLEMENTAL RESTRAINT SYSTEM (SRS)

Precautions for SRS “AIR BAG” and “SEAT BELT PRE-TENSIONER” Service

- Do not use a circuit tester to check SRS circuits unless instructed to in this Service Manual.
- Before servicing the SRS, turn ignition switch “OFF”, disconnect both battery cables and wait at least 3 minutes.
For approximately 3 minutes after the cables are removed, it is still possible for the air bag and seat belt pre-tensioner to deploy. Therefore, do not work on any SRS connectors or wires until at least 3 minutes have passed.
- Diagnosis sensor unit must always be installed with their arrow marks “↔” pointing towards the front of the vehicle for proper operation. Also check diagnosis sensor unit for cracks, deformities or rust before installation and replace as required.
- The spiral cable must be aligned with the neutral position since its rotations are limited. Do not attempt to turn steering wheel or column after removal of steering gear.
- Handle air bag module carefully. Always place it with the pad side facing upward.
- Conduct self-diagnosis to check entire SRS for proper function after replacing any components.
- After air bag inflates, the front instrument panel assembly should be replaced if damaged.

Special Service Tools

The actual shapes of Kent-Moore tools may differ from those of special service tools illustrated here.

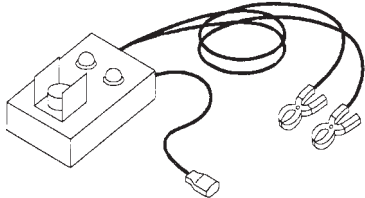
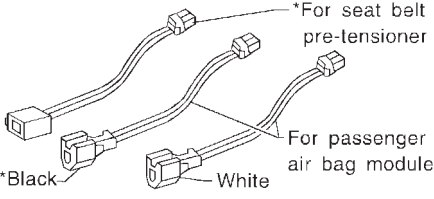
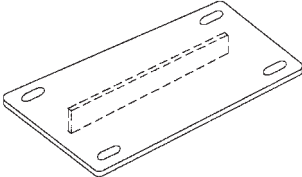
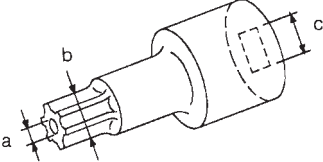
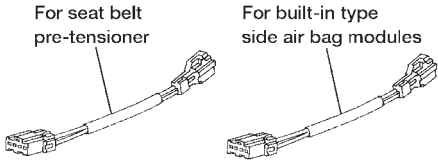
Tool number (Kent-Moore No.) Tool name	Description	
KV99106400 (J38381) Deployment tool	 NT357	Disposing of air bag module
KV991065S0 (J38381-30) Deployment tool adapters	 NT743	* Deployment tool adapters for seat belt pre-tensioner and for passenger air bag module with black connector are not necessary for servicing NISSAN L30
KV99105300 (J41246) Air bag module bracket	 NT354	Anchoring air bag module
HT61961000 and HT62152000 combined (J38219) *Special torx bit	 NT361	Use for special bolts [TAMPER RESISTANT TORX (Size T50)] a: 3.5 (0.138) dia. b: 8.5 - 8.6 (0.335 - 0.339) dia. c: approx. 10 (0.39) sq. Unit: mm (in)
KV99109000 (J44230) KV99108300 (J38381-35) Deployment tool adapters for seat belt pre-tensioner and built-in type side air bag	 WRS041	

*: Special tool or commercial equivalent

SUPPLEMENTAL RESTRAINT SYSTEM (SRS)

Description

The air bag deploys if the diagnosis sensor unit activates while the ignition switch is in "ON" or "START" position.

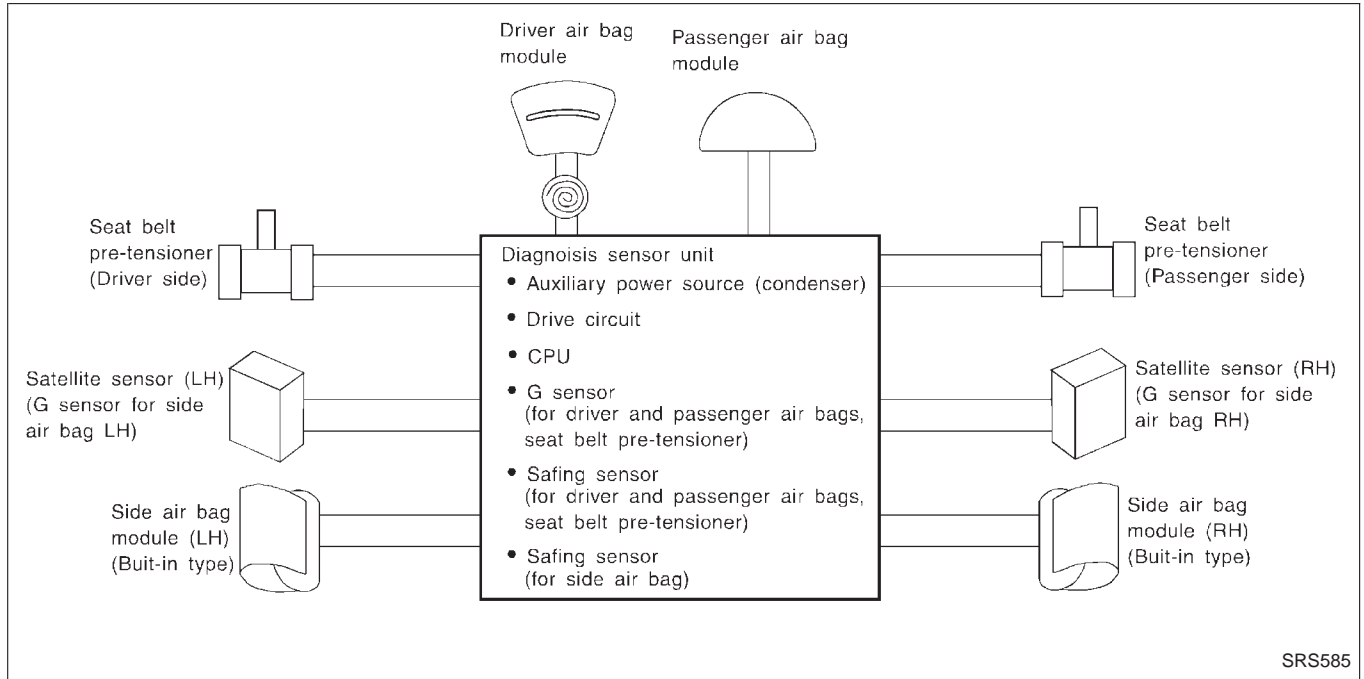

The collision modes for which supplemental restraint systems are activated are different among the SRS systems. For example, the driver air bag module and passenger air bag module are activated in a frontal collision but not in a side collision.

SRS configurations which are activated for some collision modes are as follows;

SRS configuration	Frontal collision	Left side collision	Right side collision
Driver air bag module	○	—	—
Passenger air bag module	○	—	—
Seat belt pre-tensioner (LH)	○	—	—
Seat belt pre-tensioner (RH)	○	—	—
Side air bag module (LH)	—	○	—
Side air bag module (RH)	—	—	○

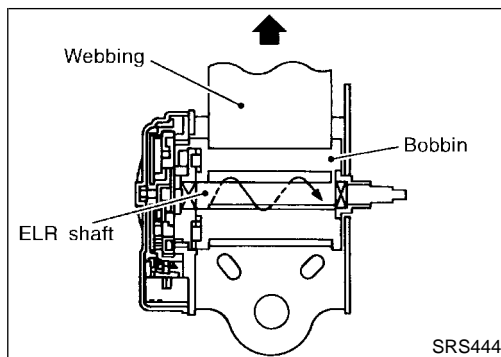

Seat Belt Pre-tensioner with Load Limiter

The seat belt pre-tensioner system with load limiter is installed to both the driver's seat and the front passenger's seat. It operates simultaneously with the SRS air bag system in the event of a frontal collision with an impact exceeding a specified level. When the frontal collision with an impact exceeding a specified level occurs, seat belt slack resulting from clothing or other factors is immediately taken up by the pre-tensioner. Vehicle passengers are securely restrained.

SUPPLEMENTAL RESTRAINT SYSTEM (SRS)

Seat Belt Pre-tensioner with Load Limiter (Cont'd)

When passengers in a vehicle are thrown forward in a collision and the restraining force of the seat belt exceeds a specified level, the load limiter permits the specified extension of the seat belt by the twisting of the ELR shaft, and a relaxation of the chest-area seat belt web tension while maintaining force.

GI
MA
EM
LC
EC
FE
CL
MT
AT
FA
RA
BR
ST
RS
BT
HA
EL
IDX

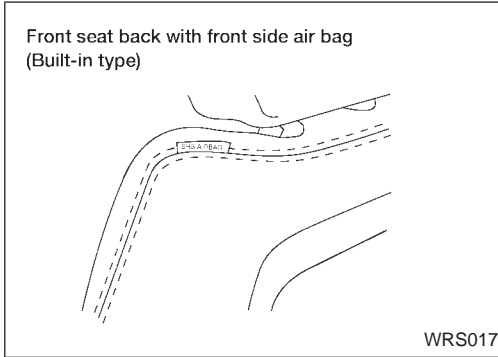

Built-in Type Side Air Bag

Front side air bag is built-in type. The front seat backs with built-in type side air bag have the labels shown in the figure at left.

SRS Component Parts Location

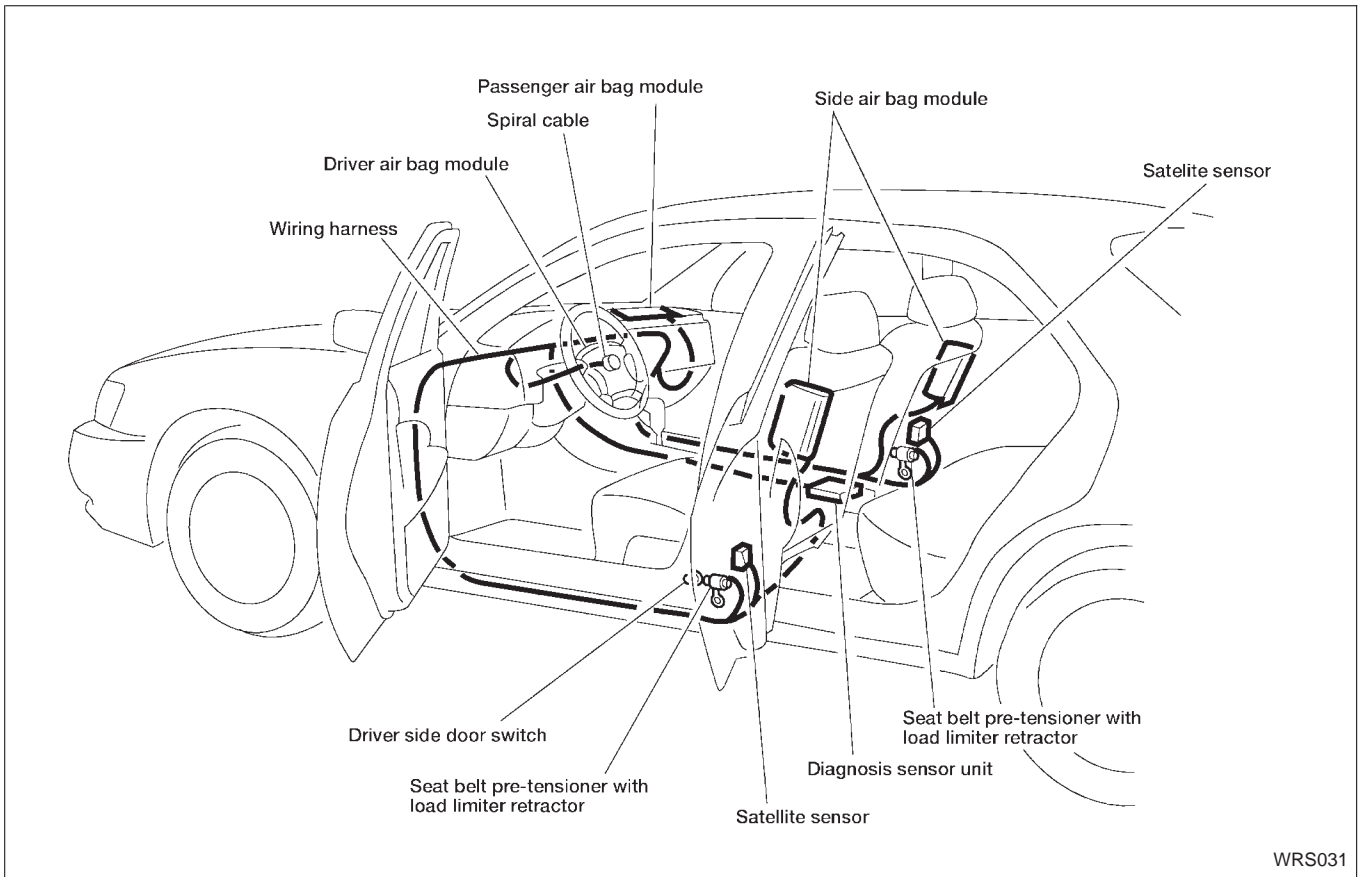

SUPPLEMENTAL RESTRAINT SYSTEM (SRS)



Maintenance Items

CAUTION:

Do not use a circuit tester to check SRS circuit.

1. Check operation of "AIR BAG" and "SEAT BELT" warning lamps.

After turning ignition key to "ON" position, both warning lamps illuminate. The "AIR BAG" warning lamp will go off after about 7 seconds if no malfunction is detected. The "SEAT BELT" warning lamp will also go off after about 7 seconds after seat belt has been fastened and no malfunction is detected. (When seat belt has not been fastened, the warning lamp continues to illuminate until seat belt is fastened.) If any of the following warning lamp conditions occur, immediately check the air bag or seat belt pre-tensioner system. Refer to RS-40 or RS-41 for details.

 - The "AIR BAG" or "SEAT BELT" warning lamp does not illuminate when the ignition switch is turned "ON".
 - The "AIR BAG" or "SEAT BELT" (with seat belt fastened) warning lamp does not go off about 7 seconds after the ignition switch is turned "ON".
 - The "AIR BAG" or "SEAT BELT" (with seat belt fastened) warning lamp blinks after about 7 seconds after the ignition switch is turned "ON".
2. Visually check SRS components.
 - (1) Diagnosis sensor unit
 - Check diagnosis sensor unit and bracket for dents, cracks and deformities.
 - Check connectors for damage and terminals for deformities.
 - (2) Air bag module and steering wheel
 - Remove air bag module from steering wheel, instrument panel or seatback. Check harness cover and connectors for damage, terminals for deformities, and harness for binding.
 - Install driver air bag module to steering wheel to check fit or alignment with the wheel.
 - Check steering wheel for excessive free play.
 - Install passenger air bag module to instrument panel to check fit or alignment with the instrument panel.
 - Install side air bag module to seatback to check fit and alignment with the seat.
 - (3) Spiral cable
 - Check spiral cable for dents, cracks and deformities.
 - Check connectors and protective tape for damage.
 - Check steering wheel for noise, binding and heavy operation.
 - (4) Main harness, air bag harness, body harness, side air bag module sub-harness
 - Check connectors for poor connections, damage, and terminals for deformities.
 - Check harnesses for binding, chafing and cuts.
 - (5) Seat belt pre-tensioner
 - Check harness cover and connectors for damage, terminals for deformities, and harness for binding.
 - Check belts for damage and anchors for loose mounting.
 - Check retractor for smooth operation.

SUPPLEMENTAL RESTRAINT SYSTEM (SRS)

Maintenance Items (Cont'd)

● Perform self-diagnosis for seat belt pre-tensioner using seat belt warning lamp or CONSULT-II. Refer to "Self-diagnosis" for details. (RS-41)

(6) Satellite sensor

- Check satellite sensor (including bracket portion) for dents, cracks or deformities.
- Check connectors for damage, and terminals for deformities.

CAUTION:

Replace previously used special bolts with new ones.

GI

MA

EM

LC

EC

FE

CL

MT

AT

FA

RA

BR

ST

RS

BT

HA

EL

IDX

SUPPLEMENTAL RESTRAINT SYSTEM (SRS)

Removal and Installation — Diagnosis Sensor Unit, Seat Belt Pre-tensioner and Satellite Sensor

CAUTION:

- Before servicing SRS, turn the ignition switch off, disconnect both battery cables and wait at least 3 minutes.
- The special bolts are coated with bonding agent while the other bolt is for ground. Do not use old bolts after removal; replace with new ones.
- Check diagnosis sensor unit, seat belt pre-tensioner and satellite sensor for proper installation.
- Check diagnosis sensor unit and satellite sensor to ensure they are free of deformities, dents, cracks or rust. If they show any visible signs of damage, replace them with new ones.
- Check diagnosis sensor unit brackets to ensure they are free of deformities and rust.
- After replacement of diagnosis sensor unit, seat belt pre-tensioner and satellite sensor, check SRS function and perform self-diagnosis for SRS. Refer to “Self-diagnosis” for details. (RS-40)
- Do not attempt to disassemble diagnosis sensor unit, seat belt pre-tensioner and satellite sensor.
- Replace diagnosis sensor unit, seat belt pre-tensioner and satellite sensor if it has been dropped or sustained an impact.
- Do not expose seat belt pre-tensioner to temperatures exceeding 80°C (176°F).

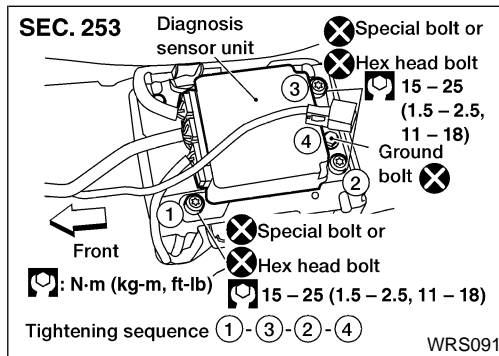

REMOVAL OF DIAGNOSIS SENSOR UNIT

1. Disconnect driver, passenger and side air bag module connectors. Also, disconnect seat belt pre-tensioner connector.
2. Remove console box. Refer to “INSTRUMENT PANEL” in BT-18 section.
3. Disconnect diagnosis sensor unit connector.
4. Remove ground bolt and also remove special bolts using the TAMPER RESISTANT TORX® (Size T50) if required or hex head bolts, from diagnosis sensor unit. Then remove the diagnosis sensor unit.

NOTE:

- To install, reverse the removal procedure. Hand start new bolts and then tighten new bolts in the sequence indicated in the illustration.

CAUTION:

Air bag diagnosis sensor unit must always be installed with forward mark “←” pointing toward the front of the vehicle for proper operation. Also check air bag diagnosis sensor unit for deformities, dents, cracks and rust before installation and replace as required.

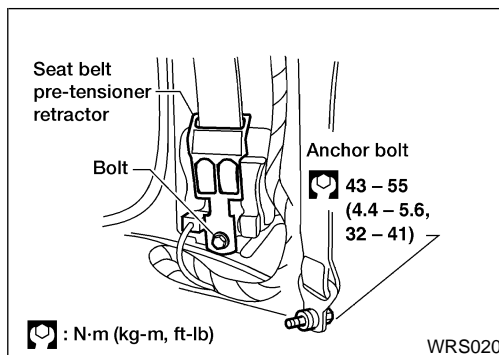

REMOVAL OF SEAT BELT PRE-TENSIONER

For removal of seat belt pre-tensioner, refer to “Front Seat Belt” for details. (RS-4)

NOTE:

- To install, reverse the removal procedure.

SUPPLEMENTAL RESTRAINT SYSTEM (SRS)

Removal and Installation — Diagnosis Sensor Unit, Seat Belt Pre-tensioner and Satellite Sensor (Cont'd)

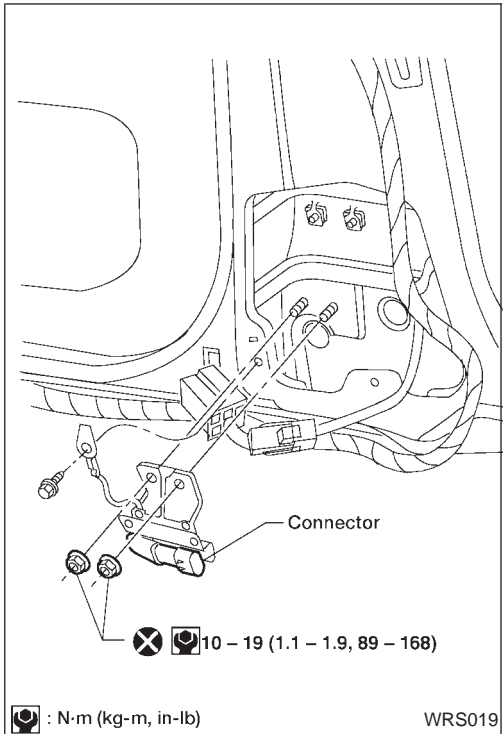

REMOVAL OF SATELLITE SENSOR

1. Remove seat belt pre-tensioner. Refer to “Front Seat Belt” for details. (RS-4)
2. Disconnect satellite sensor connector.
3. Remove bolt and nuts from satellite sensor unit. Then remove the satellite sensor.

NOTE:

- To install, reverse the removal procedure sequence.

GI
MA
EM
LC
EC
FE
CL
MT
AT
FA
RA
BR
ST
RS
BT
HA
EL
IDX

SUPPLEMENTAL RESTRAINT SYSTEM (SRS)

Removal — Air Bag Module and Spiral Cable

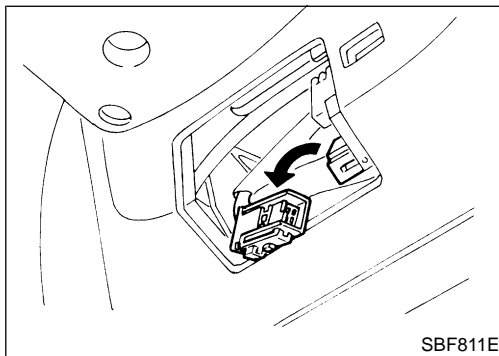
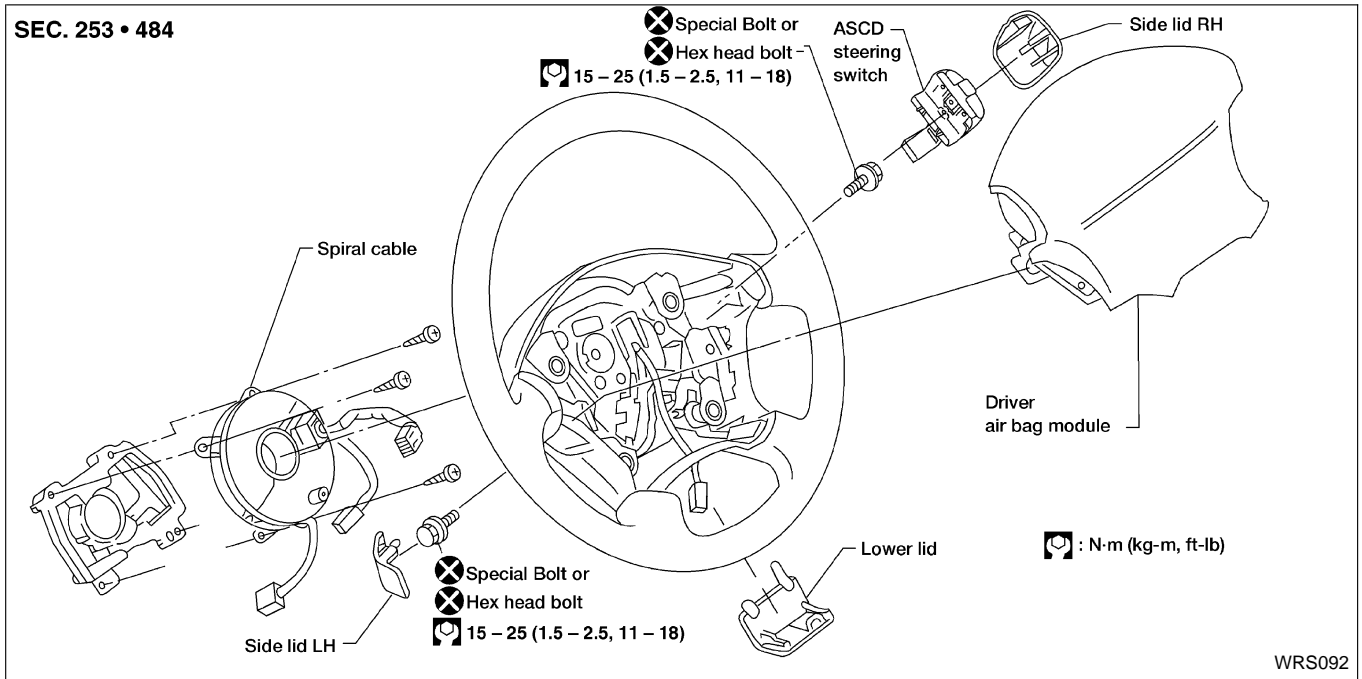

CAUTION:

- Before servicing SRS, turn the ignition switch OFF, disconnect both battery cables and wait at least 3 minutes.
 - Always work from the side of an air bag module.
1. Remove lower lid from steering wheel, and disconnect air bag module connector.

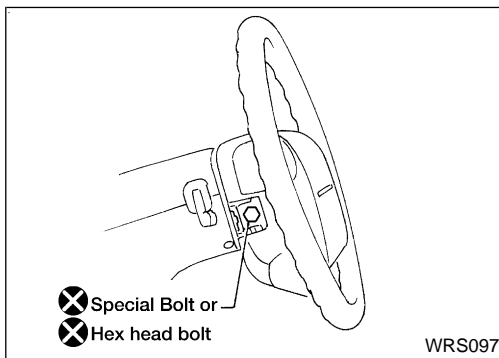

2. Remove side lids and ASCD steering switch. Remove hex head bolts or use the TAMPER RESISTANT TORX® (Size T50), if required to remove left and right special bolts. Air bag module can then be removed.

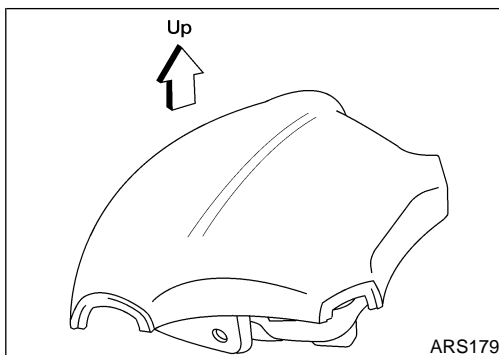

CAUTION:

- Always place air bag module with pad side facing upward.
- Do not attempt to disassemble air bag module.
- The special bolts are coated with bonding agent. Do not use old bolts after removal; replace with new ones.
- Do not insert any foreign objects (screwdriver, etc.) into air bag module connector.

SUPPLEMENTAL RESTRAINT SYSTEM (SRS)

Removal — Air Bag Module and Spiral Cable (Cont'd)

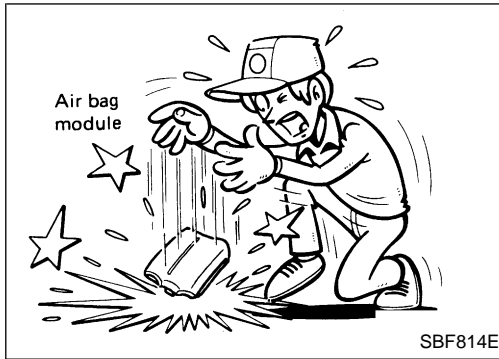

- Replace air bag module if it has been dropped or sustained an impact.
- Do not expose the air bag module to temperatures exceeding 90°C (194°F).
- Do not allow oil, grease or water to come in contact with the air bag module.

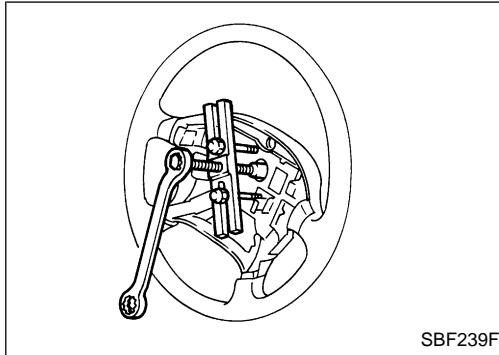

3. Set steering wheel in the neutral position.
4. Disconnect horn connector and remove steering wheel nut.
5. Using steering wheel puller, remove steering wheel. Be careful not to over-tighten puller bolt on steering wheel.

CAUTION:

- Do not tap or bump the steering wheel.
6. Remove driver side instrument lower panel.

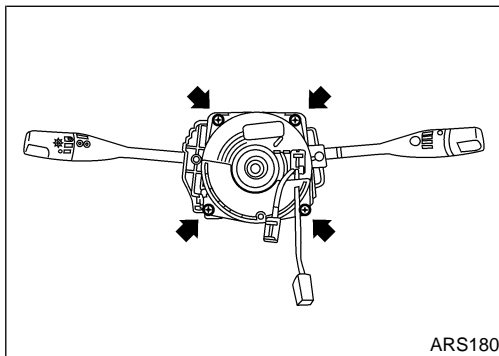

7. Remove steering column covers.
8. Disconnect spiral cable and driver air bag harness connectors.
9. Remove the four spiral cable retaining screws. The spiral cable can then be removed.

CAUTION:

- Do not attempt to disassemble spiral cable.
- Do not apply lubricant to the spiral cable.

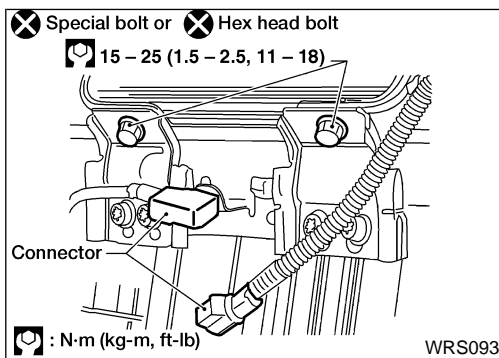

Removal — Front Passenger Air Bag Module

CAUTION:

- Before servicing SRS, turn the ignition switch OFF, disconnect both battery cables and wait for at least 3 minutes.
 - Always work from the side of or under air bag module.
1. Remove glove box assembly.
 2. Disconnect air bag module connector.
 3. Remove RH upper knee protector.
 4. Remove RH side ventilator duct.
 5. Remove two hex head bolts or if required use TAMPER RESISTANT TORX® (Size T50) to remove the two special bolts.
 6. Remove three mounting bolts.

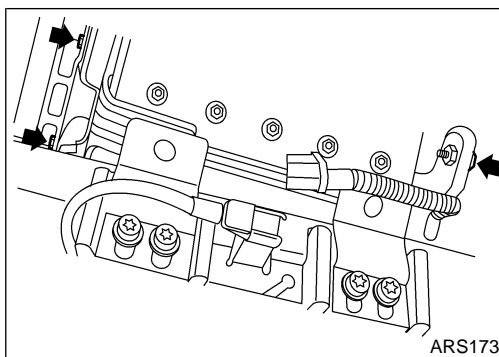

GI
MA
EM
LC
EC
FE
CL
MT
AT
FA
RA
BR
ST
RS
BT
HA
EL
IDX

SUPPLEMENTAL RESTRAINT SYSTEM (SRS)

Removal — Front Passenger Air Bag Module (Cont'd)

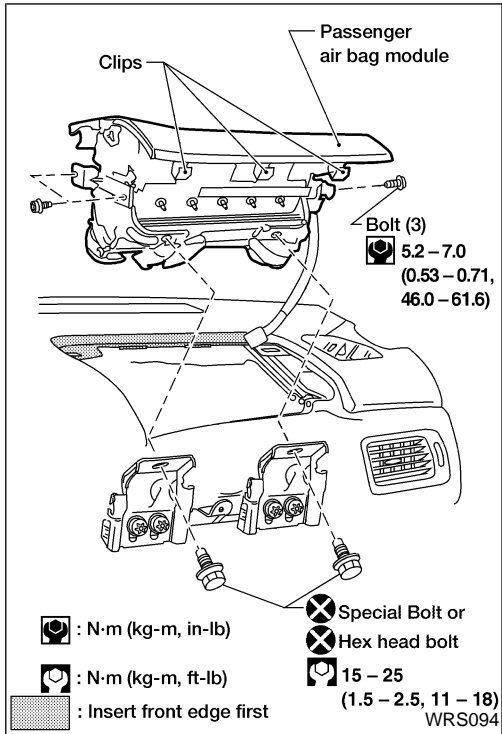

- Remove air bag module by releasing the clips from the top of the instrument panel.
- Air bag module is heavy and should be supported using both hands during removal.

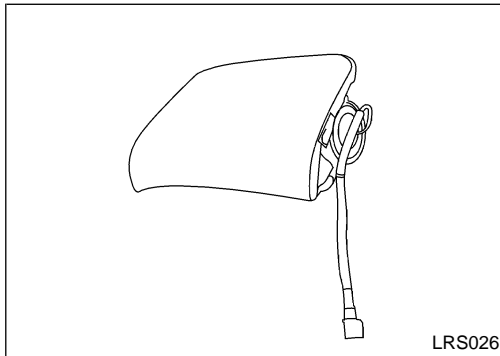

CAUTION:

- Always place air bag module with pad side facing upward.
- Do not attempt to disassemble air bag module.
- The special bolts are coated with bonding agent. Do not use old bolts after removal; replace with new coated bolts.
- Do not insert any foreign objects (screwdriver, etc.) into air bag module connector.



- Do not drop or impact air bag module. If any portion is deformed or cracked, replace the module.
- Do not expose the air bag module to temperatures exceeding 90°C (194°F).
- Do not allow oil, grease or water to come in contact with the air bag module.

SUPPLEMENTAL RESTRAINT SYSTEM (SRS)

Removal — Side Air Bag Module

CAUTION:

- Before servicing SRS, turn the ignition switch OFF, disconnect both battery cables and wait at least 3 minutes.
- Always work from the rear of the air bag module.

1. Remove seat. Refer to "SEAT" BT-34.
2. Remove the headrest.

GI

MA

EM

LC

EC

FE

CL

MT

AT

FA

RA

BR

ST

RS

BT

HA

EL

IDX

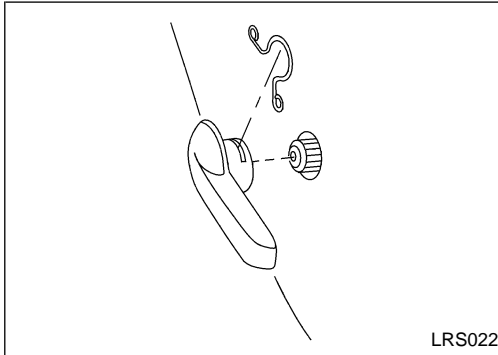

3. Remove the lumbar support handle (if equipped).
4. Remove the seat back board.

- When using a clip removal tool to remove the seat back board, take care not to damage the air bag harness.

5. Disconnect the seat back trim cover J-clips from seat back frame.

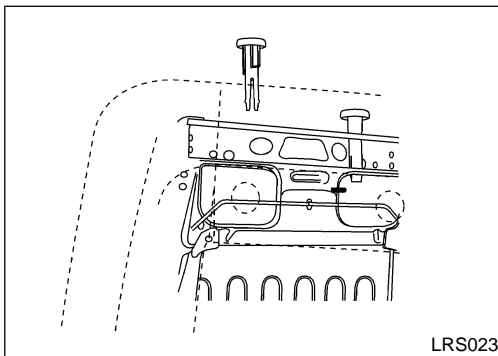

6. Remove the headrest guide tubes.

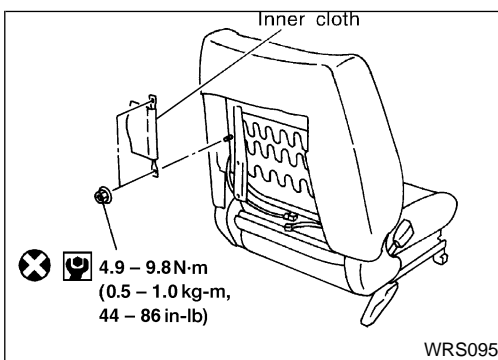

7. Remove the nuts securing the inner cloth with seat back frame. Then pull up the inner cloth.

8. Remove the seat back trim cover and foam.

9. Remove the seatback friction cover (plastic bag).

10. Disconnect the side air bag harness.

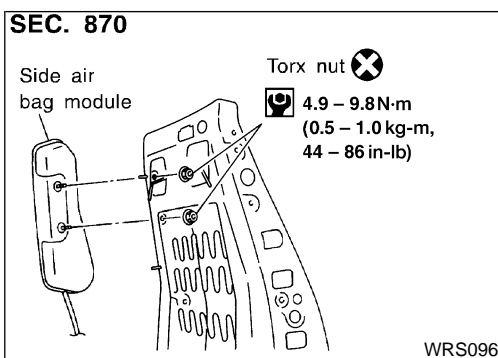

11. Remove the Torx® nuts coated with bonding agent from the side air bag, remove the side air bag module.

SUPPLEMENTAL RESTRAINT SYSTEM (SRS)

Removal — Side Air Bag Module (Cont'd)

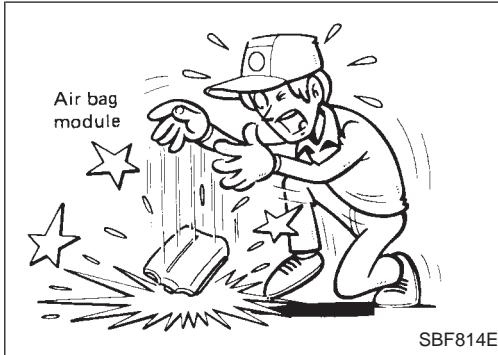
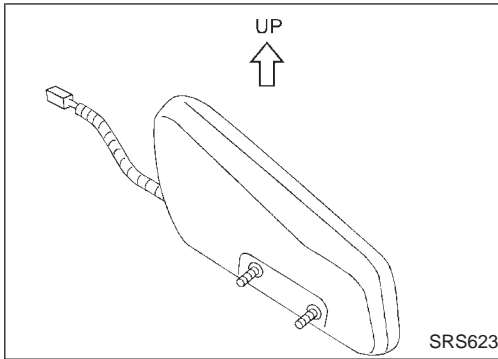

CAUTION:

- Always place the air bag module with the stud bolt side facing down.
- Do not attempt to disassemble air bag module.
- The torx nuts are coated with bonding agent. Do not use old nuts after removal; replace with new coated nuts.
- Do not insert any foreign objects (screwdriver, etc.) into air bag module connector.
- Replace air bag module if it has been dropped or sustained an impact.
- Do not expose the air bag module to temperatures exceeding 90°C (194°F).
- Do not allow oil, grease or water to come in contact with the air bag module.
- After air bag inflates, all parts of front seat back (including front seat back frame) should be replaced.

Installation — Air Bag Module and Spiral Cable

INSTALLATION

1. Set the front wheels in the straight-ahead position.
 2. Rotate the spiral cable fully clockwise until tight.
 3. Rotate the spiral cable counterclockwise approximately 2.5 turns and align white pin with arrow on housing.
- When spiral cable is centered, white pin is aligned with arrow on housing and yellow wheel shows in window.

CAUTION:

The spiral cable may snap during steering operation if the cable is installed improperly. Also, with the steering linkage disconnected, the cable may snap by turning the steering wheel more than 2.5 turns to the left or right of the neutral position.

4. Connect spiral cable and driver air bag harness connectors and tighten screws. Install steering column covers and driver side instrument lower panel.

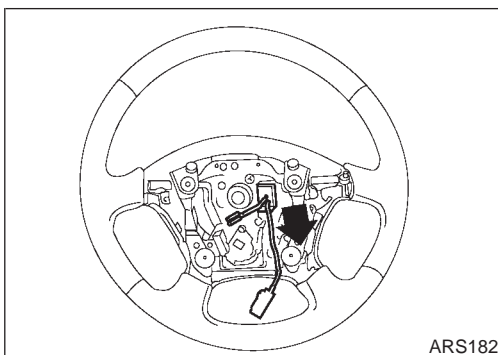
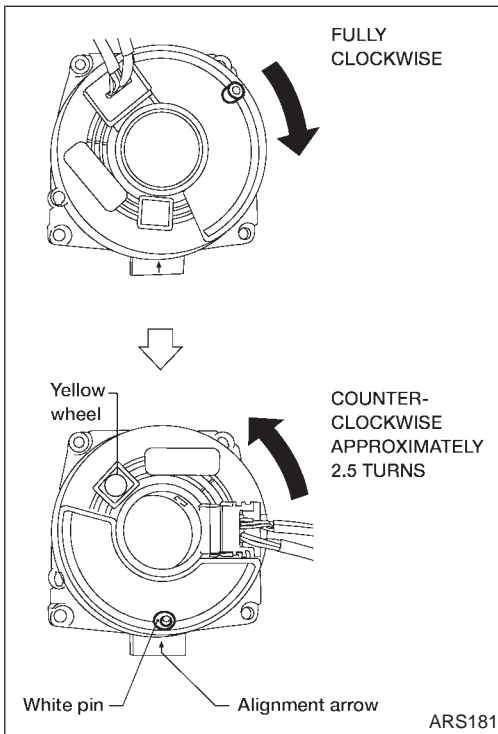

5. Install steering wheel, setting spiral cable pin guide, and pull spiral cable connectors through.
6. Connect horn connector and engage spiral cable with pawls in steering wheel.
7. Tighten steering wheel nut.

: 29 - 39 N·m (3.0 - 4.0 kg-m, 22 - 29 ft-lb)

SUPPLEMENTAL RESTRAINT SYSTEM (SRS)

Installation — Air Bag Module and Spiral Cable (Cont'd)

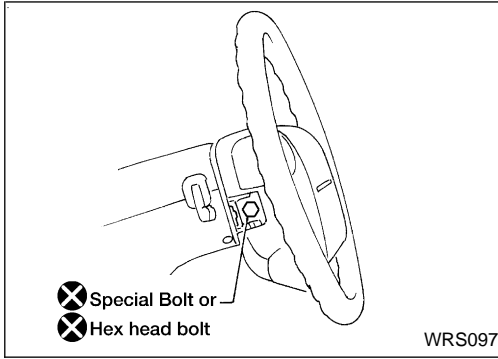

8. Position driver air bag module and install two new hex head or two new special bolts [use TAMPER RESISTANT TORX® (Size T50) if required].

: 15 - 25 N·m (1.5 - 2.5 kg-m, 11 - 18 ft-lb)

9. Connect driver air bag module connector.
10. Install all lids and ASCD steering switch.
11. Connect both battery cables.
12. Conduct Self-diagnosis to ensure entire SRS operates properly. (Use CONSULT-II or warning lamp check.) Turn the steering wheel fully to the right and left to check that the spiral cable is set in the neutral position.
13. If air bag warning lamp blinks (in User mode), it shows the spiral cable may be snapped due to its improper position. Perform self-diagnosis again. (Use CONSULT-II or warning lamp check.) If a malfunction is detected, replace the spiral cable with a new one.

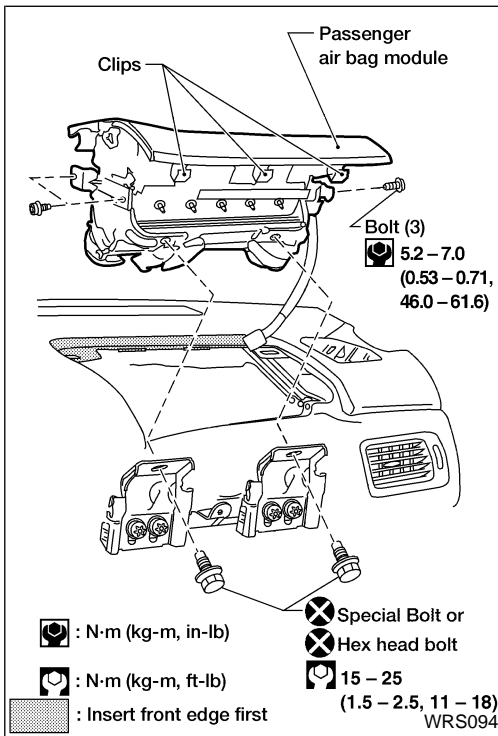

Installation — Front Passenger Air Bag Module

1. Install passenger air bag module in instrument panel.
 - Insert front edge of air bag module first to ease installation.
 - Ensure harness is not caught between air bag module and support bracket.
 - Install three mounting bolts.
 - Install two new hex head or two special bolts [use TAMPER RESISTANT TORX® (Size T50) if required].

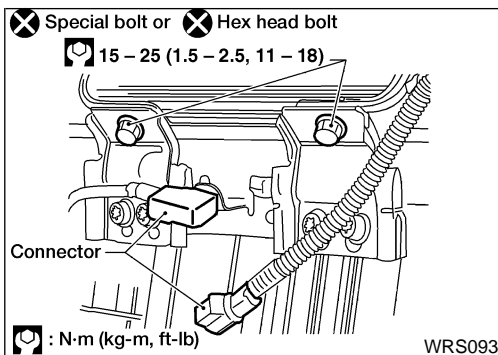

2. Connect passenger air bag module connector to air bag harness.
3. Install glove box assembly.
4. Conduct Self-diagnosis to ensure SRS operates properly. (Use CONSULT-II or warning lamp check.)

GI
MA
EM
LC
EC
FE
CL
MT
AT
FA
RA
BR
ST
RS
BT
HA
EL
IDX

SUPPLEMENTAL RESTRAINT SYSTEM (SRS)

SEC. 870

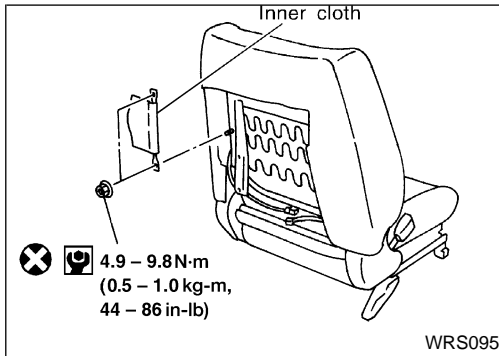
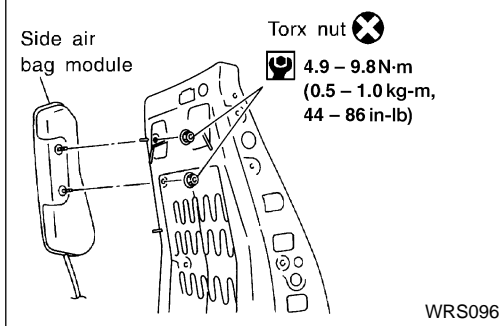

Installation — Side Air Bag Module

1. Install side air bag module on seat back frame with new Torx® nuts coated with bonding agent.
2. Connect side air bag connector.
3. Install seat back finisher with screw.
4. Secure the inner cloth which covers the side air bag module with nuts.
5. Conduct self-diagnosis to ensure SRS operates properly. (Use CONSULT-II or warning lamp check).

Disposal of Air Bag Module and Seat Belt Pre-tensioner

- Before disposing of air bag module and seat belt pre-tensioner, or vehicles equipped with such systems, deploy the systems. If such systems have already been deployed due to an accident, dispose of them as indicated in “DISPOSING OF AIR BAG MODULE AND SEAT BELT PRE-TENSIONER” (RS-30).
- When deploying the air bag module and seat belt pre-tensioner, always use the Special Service Tool; Deployment tool KV99106400 (Kent-Moore No. J38381).
- When deploying the air bag module and seat belt pre-tensioner, stand at least 5 m (16 ft) away from the deployment component.
- When deploying air bag module and seat belt pre-tensioner, a fairly loud noise is made, followed by smoke being released. The smoke is not poisonous, however, be careful not to inhale smoke since it irritates the throat and can cause choking.
- Always activate one air bag module at a time.
- Due to heat, leave air bag module unattended for more than 30 minutes after deployment. Also leave seat belt pre-tensioner unattended for more than 10 minutes after deployment.
- Be sure to wear gloves when handling a deployed air bag module and seat belt pre-tensioner.
- Never apply water to the deployed air bag module and seat belt pre-tensioner.
- Wash your hands clean after finishing work.
- Place the vehicle outdoors with an open space of at least 6 m (20 ft) on all sides when deploying air bag module and seat belt pre-tensioner while mounted in vehicle.
- Use a voltmeter to make sure the vehicle battery is fully charged.
- Do not dispose of the air bag module and seat belt pre-tensioner un-deployed.

SUPPLEMENTAL RESTRAINT SYSTEM (SRS)

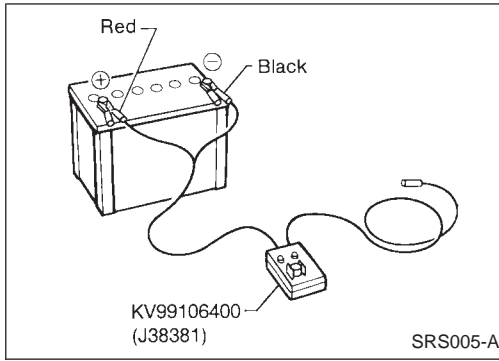

Disposal of Air Bag Module and Seat Belt Pre-tensioner (Cont'd)

CHECKING DEPLOYMENT TOOL

Connecting to battery

CAUTION:

The battery must show voltage of 9.6V or more.

Remove the battery from the vehicle and place it on dry wood blocks approximately 5 m (16 ft) away from the vehicle.

- Wait 3 minutes after the vehicle battery is disconnected before proceeding.
- Connect red clip of deployment tool to battery positive terminal and black clip to negative terminal.

Make sure the polarity is correct. The right side lamp in the tool, marked "deployment tool power", should glow with a green light. If the right side lamp glows red, reverse the connections to the battery.

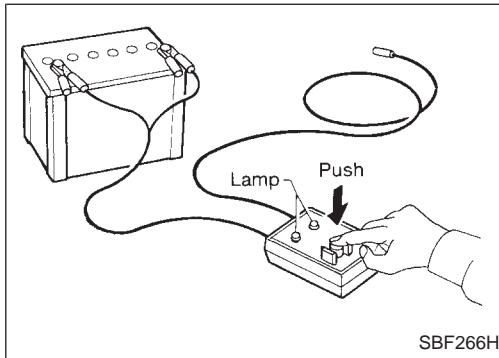

Deployment tool check

Press the deployment tool switch to the "ON" position. The left side lamp in the tool, marked "air bag connector voltage" should illuminate. If it does not illuminate, replace the tool.

Air bag deployment tool lamp illumination chart (Battery connected)

Switch operation	Left side lamp, green* "AIR BAG CONNECTOR VOLTAGE"	Right side lamp, green* "DEPLOYMENT TOOL POWER"
OFF	OFF	ON
ON	ON	ON

*: If this lamp glows red, the tool is connected to the battery incorrectly. Reverse the connections and make sure the lamp glows green.

GI

MA

EM

LC

EC

FE

CL

MT

AT

FA

RA

BR

ST

RS

BT

HA

EL

IDX

SUPPLEMENTAL RESTRAINT SYSTEM (SRS)

Disposal of Air Bag Module and Seat Belt Pre-tensioner (Cont'd)

DEPLOYMENT PROCEDURES FOR AIR BAG MODULE (OUTSIDE OF VEHICLE)

Unless the vehicle is being scrapped, deploying the air bag in the vehicle is not recommended. This may cause damage to the vehicle interior.

Anchor air bag module bracket [KV99105300 (J41246)] in a vise secured to a firm foundation during deployment.

Deployment of driver's air bag module (outside of vehicle)

1. Using wire, secure air bag module to air bag module bracket [SST: KV99105300 (J41246)] at two places.

CAUTION:

Use wire of at least 1 mm (0.04 in) diameter.

2. Firmly secure air bag module bracket [SST: KV99105300 (J41246)] with air bag module attached, in a vise.

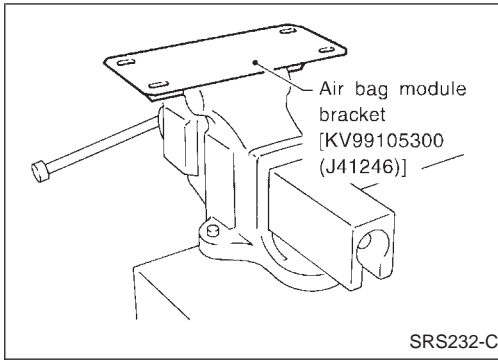

SRS232-C

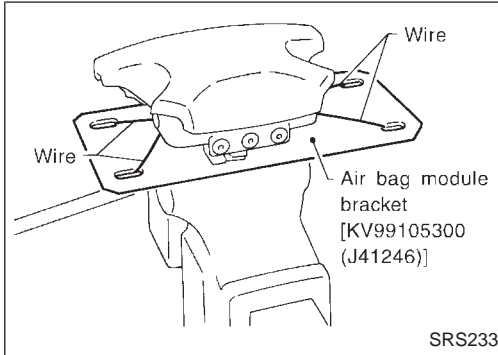

SRS233

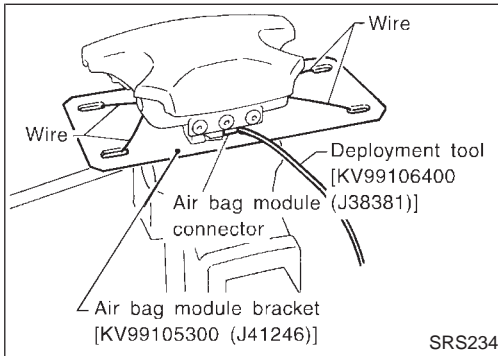

SRS234

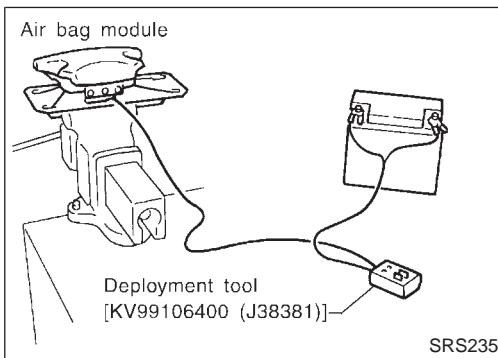

SRS235

3. Connect deployment tool [SST: KV99106400 (J38381)] to air bag module connector.

4. Connect red clip of deployment tool to battery positive terminal and black clip to negative terminal.

5. The lamp on the right side of the tool, marked "deployment tool power", should glow green, not red.

6. Press the button on the deployment tool. The left side lamp on the tool, marked "air bag connector voltage", will illuminate and the air bag module will deploy.

CAUTION:

When deploying the air bag module, stand at least 5 m (16 ft) away from the air bag module.

Deployment of passenger air bag module (outside of vehicle)

1. Make an 8.5 mm (0.335 in) diameter hole in air bag module bracket [SST: KV99105300 (J41246)] at the position shown in figure at left.

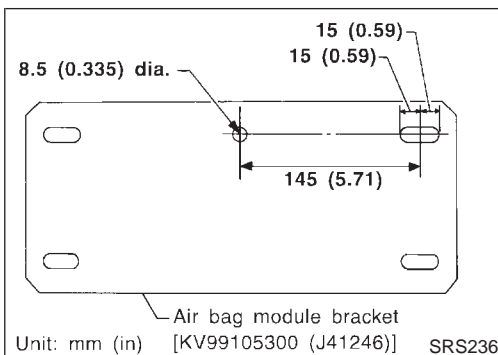

Unit: mm (in) [KV99105300 (J41246)] SRS236

SUPPLEMENTAL RESTRAINT SYSTEM (SRS)

Disposal of Air Bag Module and Seat Belt Pre-tensioner (Cont'd)

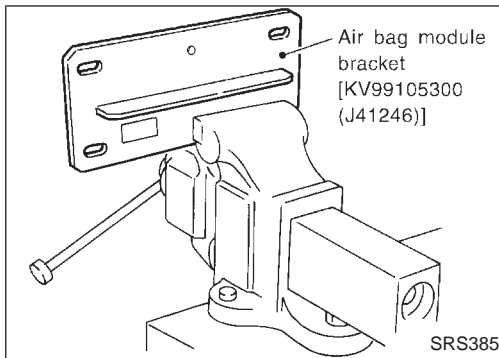

2. Firmly secure air bag module bracket [SST: KV99105300 (J41246)] in a vise.

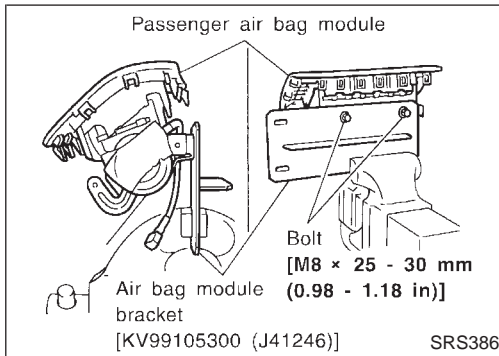

3. Match the two holes in air bag module bracket (held in vise) and passenger air bag module and fix them with two bolts [M8 x 25 - 30 mm (0.98 - 1.18 in)].

CAUTION:

If a gap exists between passenger air bag module and air bag module bracket, use a piece of wood inserted in the gap to stabilize the air bag module.

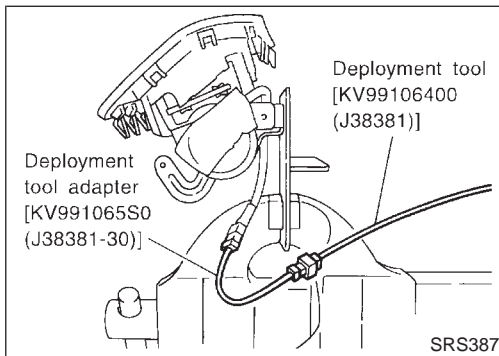

4. Connect deployment tool adapter [SST: KV991065S01 (J38381-30)] to deployment tool [SST: KV99106400 (J38381)] connector and connector on either side of air bag module.
5. Connect red clip of deployment tool to battery positive terminal and black clip to negative terminal.
6. The lamp on the right side of the tool, marked "deployment tool power", should glow green, not red.
7. Press the button on the deployment tool. The left side lamp on the tool, marked "air bag connector voltage", will illuminate and the air bag module will deploy.

CAUTION:

- When deploying the air bag module, do not stand on the deploying side.
- Stand at least 5 m (16 ft) away from the air bag module.

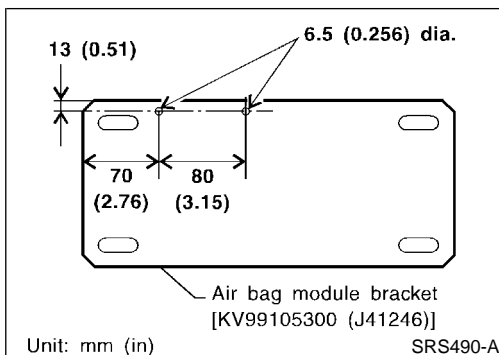
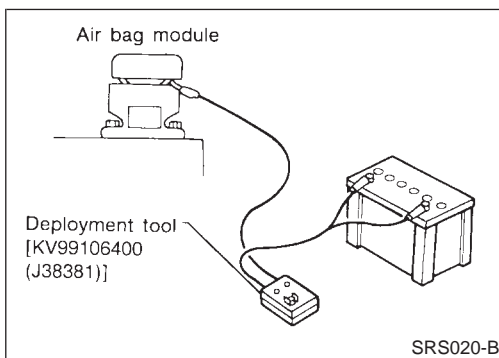

Deployment of Side Air Bag Module (Built-in type) (Outside of vehicle)

1. Make 6.5 mm (0.256 in) diameter holes in air bag module bracket [SST: KV99105300 (J41246)] at the position shown in figure at left.

GI
MA
EM
LC
EC
FE
CL
MT
AT
FA
RA
BR
ST
RS
BT
HA
EL
IDX

SUPPLEMENTAL RESTRAINT SYSTEM (SRS)

Disposal of Air Bag Module and Seat Belt Pre-tensioner (Cont'd)

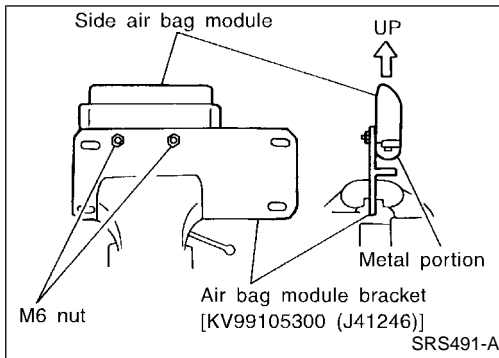

2. Firmly secure air bag module bracket [SST: KV99105300 (J41246)] in a vise.
3. Insert the stud bolts of side air bag module (built-in type) into the two holes in air bag module bracket (held in vise) and fix them with two M6 nuts.

CAUTION:

Side air bag module should be secured to air bag module bracket [SST: KV99105300 (J41246)] in a vise with metal portion facing down.

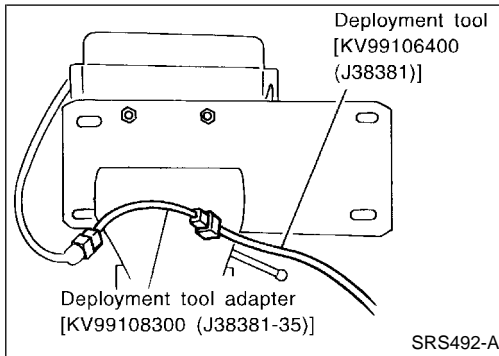

4. Connect deployment tool adapter [SST: KV99108300 (J38381-35)] to deployment tool [SST: KV99106400 (J38381)] connector and connector on air bag module.

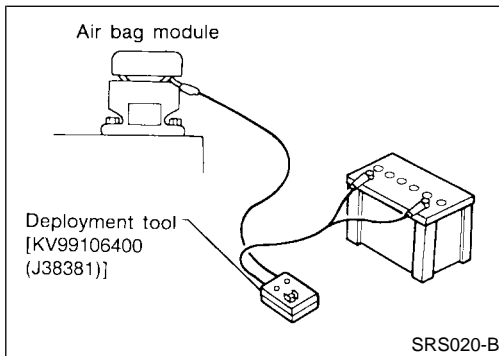

5. Connect red clip of deployment tool to battery positive terminal and black clip to negative terminal.
6. The lamp on the right side of the tool, marked "deployment tool power", should glow green, not red.
7. Press the button on the deployment tool. The left side lamp on the tool, marked "air bag connector voltage", will illuminate and the air bag module will deploy.

CAUTION:

When deploying the air bag module, stand at least 5 m (16 ft) away from the air bag module.

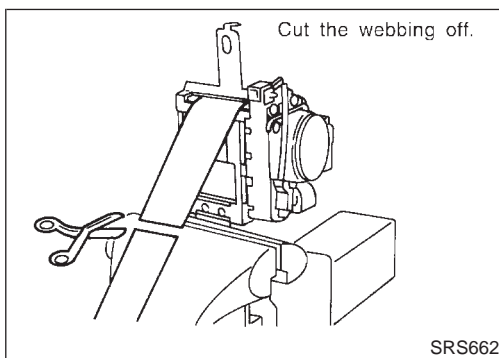

DEPLOYMENT PROCEDURES FOR SEAT BELT PRE-TENSIONER (OUTSIDE OF VEHICLE)

1. Firmly grip pre-tensioner in a vise and cut the webbing off.

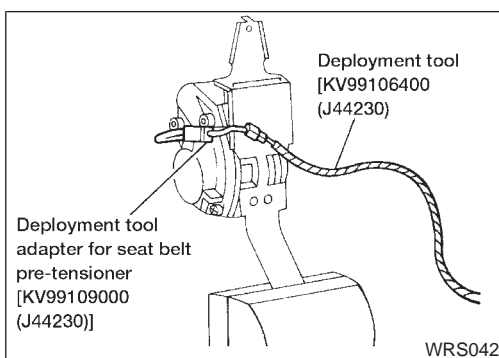

2. Connect deployment tool adapter [SST: KV99109000 (J44230)] to deployment tool [SST: KV99106400 (J38381)] connector and seat belt pre-tensioner connector.

SUPPLEMENTAL RESTRAINT SYSTEM (SRS)

Disposal of Air Bag Module and Seat Belt Pre-tensioner (Cont'd)

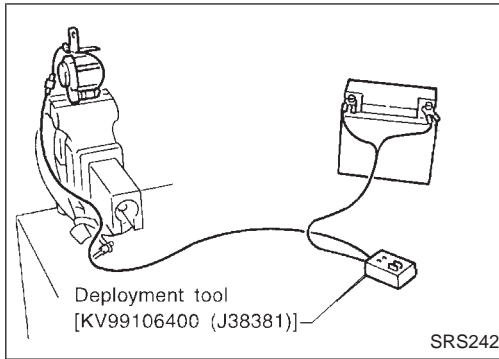

3. Connect red clip of deployment tool to battery positive terminal and black clip to negative terminal.
4. The lamp on the right side of the tool, marked "deployment tool power", should glow green, not red.
5. Press the button on the deployment tool. The left side lamp on the tool, marked "seat belt pre-tensioner connector voltage", will illuminate and the seat belt pre-tensioner will deploy.

CAUTION:

When deploying the seat belt pre-tensioner, stand at least 5 m (16 ft) away from the seat belt pre-tensioner.

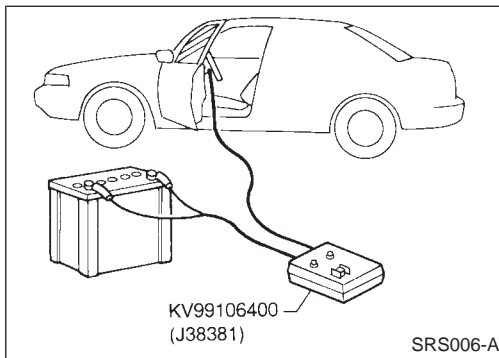

DEPLOYMENT OF AIR BAG MODULE AND SEAT BELT PRE-TENSIONER WHILE MOUNTED IN VEHICLE

When disposing of a vehicle, deploy air bag modules and seat belt pre-tensioners while they are mounted in vehicle.

CAUTION:

When deploying air bag module or seat belt pre-tensioner, ensure vehicle is empty.

1. Disconnect both vehicle battery cables and wait 3 minutes.
2. Disconnect air bag modules and seat belt pre-tensioners connector.
3. Connect deployment tool [SST: KV99106400 (J38381)] to air bag module or seat belt pre-tensioner.
For front passenger air bag module, attach deployment tool adapter [SST: KV991065S0 (J38381-30)] to the tool connector.
For seat belt pre-tensioner, attach deployment tool adapter [SST: KV99109000 (J44230)] to the tool connector.
4. Connect red clip of deployment tool to battery positive terminal and black clip to negative terminal.
5. The lamp on the right side of the tool, marked "deployment tool power", should glow green, not red.
6. Press the button on the deployment tool. The left side lamp on the tool, marked "air bag connector voltage", will illuminate and the air bag module or seat belt pre-tensioner will deploy.

CAUTION:

Activate only one air bag module or seat belt pre-tensioner at a time.

SUPPLEMENTAL RESTRAINT SYSTEM (SRS)

Disposal of Air Bag Module and Seat Belt Pre-tensioner (Cont'd)

DISPOSING OF AIR BAG MODULE AND SEAT BELT PRE-TENSIONER

Deployed air bag modules and seat belt pre-tensioners are very hot. Before disposing of air bag module, and seat belt pre-tensioner, wait at least 30 minutes, and 10 minutes, respectively. Seal them in a plastic bag before disposal.

CAUTION:

- Never apply water to a deployed air bag module and seat belt pre-tensioner.
- Be sure to wear gloves when handling a deployed air bag module and seat belt pre-tensioner.
- No poisonous gas is produced upon air bag module deployment. However, be careful not to inhale gas since it irritates throat and can cause choking.
- Do not attempt to disassemble air bag module and seat belt pre-tensioner.
- Air bag module and seat belt pre-tensioner cannot be re-used.
- Wash your hands clean after finishing work.

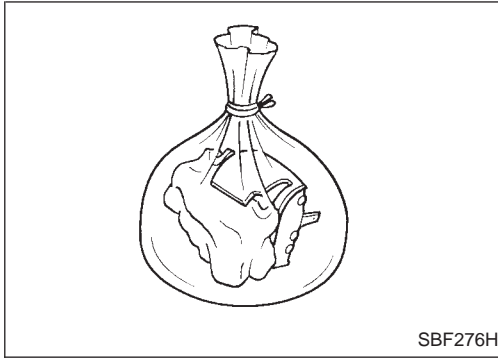

Trouble Diagnoses Introduction

CAUTION:

- Do not use a circuit tester to check SRS harness connectors unless instructed to in this Service Manual. SRS wiring harnesses (except “SEAT BELT PRE-TENSIONER” connector) can be identified by yellow harness connector (and with yellow harness protector or yellow insulation tape before the harness connectors).
- Do not attempt to repair, splice or modify the SRS wiring harness. If the harness is damaged, replace it with a new one.
- Keep ground portion clean.

DIAGNOSIS FUNCTION

The SRS self-diagnosis results can be read by using “AIR BAG” warning lamp, “SEAT BELT” warning lamp and/or CONSULT-II. The reading of these results is accomplished using one of two modes — “User mode” and “Diagnosis mode”.

The User mode is exclusively prepared for the customer (driver). This mode warns the driver of a system malfunction through the operation of the “AIR BAG” warning lamp and/or “SEAT BELT” warning lamp. The Diagnosis mode allows the technician to locate and inspect the malfunctioning part.

The mode applications for the “AIR BAG” warning lamp, “SEAT BELT” warning lamp and CONSULT-II are as follows:

	User mode	Diagnosis mode	Display type
“AIR BAG” warning lamp	X	X	ON-OFF operation
“SEAT BELT” warning lamp	X	—	ON-OFF operation
CONSULT-II	—	X	Monitoring

DIAGNOSIS MODE FOR CONSULT-II

- “SELF-DIAG [CURRENT]”
A current Self-diagnosis result (also indicated by the warning lamp flashes in the Diagnosis mode) is displayed on the CONSULT-II screen in real time. This refers to a malfunctioning part requiring repairs.
- “SELF-DIAG [PAST]”
Diagnosis results previously stored in the memory (also indicated by the warning lamp flashes in the Diagnosis mode) are displayed on the CONSULT-II screen. The stored results are not erased until memory erasing is executed.
- “TROUBLE DIAG RECORD”
With “TROUBLE DIAG RECORD”, diagnosis results previously erased by a reset operation can be displayed on the CONSULT-II screen.

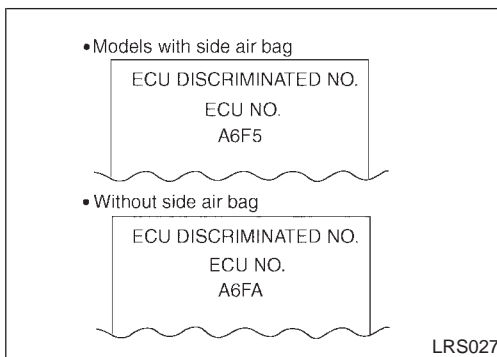

- “ECU DISCRIMINATED NO.”
The diagnosis sensor unit for each vehicle model is assigned with its own, individual classification number. This number will be displayed on the CONSULT-II screen, as shown at left. When replacing the diagnosis sensor unit, refer to the part number for the compatibility. After installation, replacement with a correct unit can be checked by confirming this classification number on the CONSULT-II screen.

For NISSAN MODEL L30, the diagnosis sensor unit classification numbers assigned are A6F5 (models with side air bags), or A6FA (models without side air bags).

TROUBLE DIAGNOSES — Supplemental Restraint System (SRS)

Trouble Diagnoses Introduction (Cont'd)

HOW TO CHANGE SELF-DIAGNOSIS MODE

With CONSULT-II

From User mode to Diagnosis mode

After selecting AIR BAG on the “SELECT SYSTEM” screen, User mode automatically changes to Diagnosis mode.



From Diagnosis mode to User mode

To return to User mode from diagnosis mode, touch “BACK” key of CONSULT-II until “SELECT SYSTEM” appears. Diagnosis mode automatically changes to User mode.

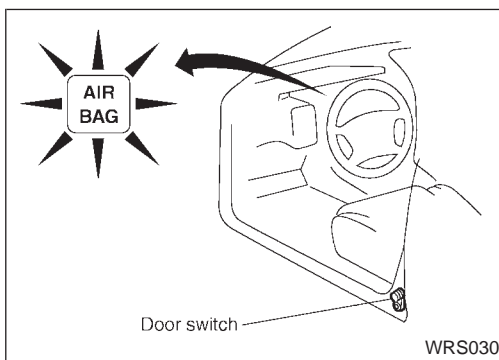

Without CONSULT-II

From User mode to Diagnosis mode

Diagnosis mode activates only when a malfunction is detected, by pressing the driver's door switch at least 5 times within 7 seconds after turning the ignition “ON”. SRS will not enter Diagnosis mode if no malfunction is detected.

From Diagnosis mode to User mode

After a malfunction is repaired, switch the ignition “OFF” for at least 1 second, then back “ON”. Diagnosis mode returns to User mode. If switching Diagnosis mode to User mode is required while malfunction is being detected, switch the ignition “OFF”, then back “ON” and press the driver's door switch at least 5 times within 7 seconds.

TROUBLE DIAGNOSES — Supplemental Restraint System (SRS)

Trouble Diagnoses Introduction (Cont'd)

HOW TO ERASE SELF-DIAGNOSIS RESULTS

With CONSULT-II

- “SELF-DIAG [CURRENT]”
A current Self-diagnosis result is displayed on the CONSULT-II screen in real time. After the malfunction is repaired completely, no malfunction is detected on “SELF-DIAG [CURRENT]”.

GI

MA

EM

LC

EC

FE

CL

MT

AT

FA

RA

BR

ST

RS

BT

HA

EL

IDX

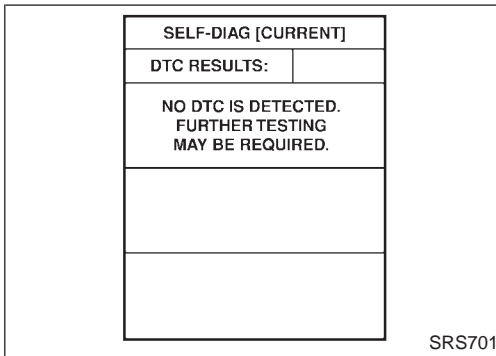

- “SELF-DIAG [PAST]”
Return to the “SELF-DIAG [CURRENT]” CONSULT-II screen by pushing “BACK” key of CONSULT-II and select “SELF-DIAG [CURRENT]” in “SELECT DIAG MODE”. Touch “ERASE” in “SELF-DIAG [CURRENT]” mode.

NOTE:

If the memory of the malfunction in “SELF-DIAG [PAST]” is not erased, the User mode shows the system malfunction by the operation of the warning lamp even if the malfunction is repaired completely.

- “TROUBLE DIAG RECORD”
The memory of “TROUBLE DIAG RECORD” cannot be erased.

Without CONSULT-II

After a malfunction is repaired, return to User mode from Diagnosis mode by switching the ignition “OFF” for at least 1 second, then back “ON”. At that time, the self-diagnosis result is cleared.

How to Perform Trouble Diagnoses for Quick and Accurate Repair

A good understanding of the malfunction conditions can make troubleshooting faster and more accurate. In general, each customer feels differently about a malfunction. It is important to fully understand the symptoms or conditions for a customer complaint.

INFORMATION FROM CUSTOMER

WHAT Vehicle model
WHEN Date, Frequencies
WHERE Road conditions
HOW Operating conditions, Symptoms

PRELIMINARY CHECK

Check that the following parts are in good order.

- Battery [Refer to EL-27 section (“BATTERY”).]
- Fuse [Refer to EL-18 section (“Fuse”, “POWER SUPPLY ROUTING”).]
- System component-to-harness connections

TROUBLE DIAGNOSES — Supplemental Restraint System (SRS)

How to Perform Trouble Diagnoses for Quick and Accurate Repair (Cont'd)

WORK FLOW

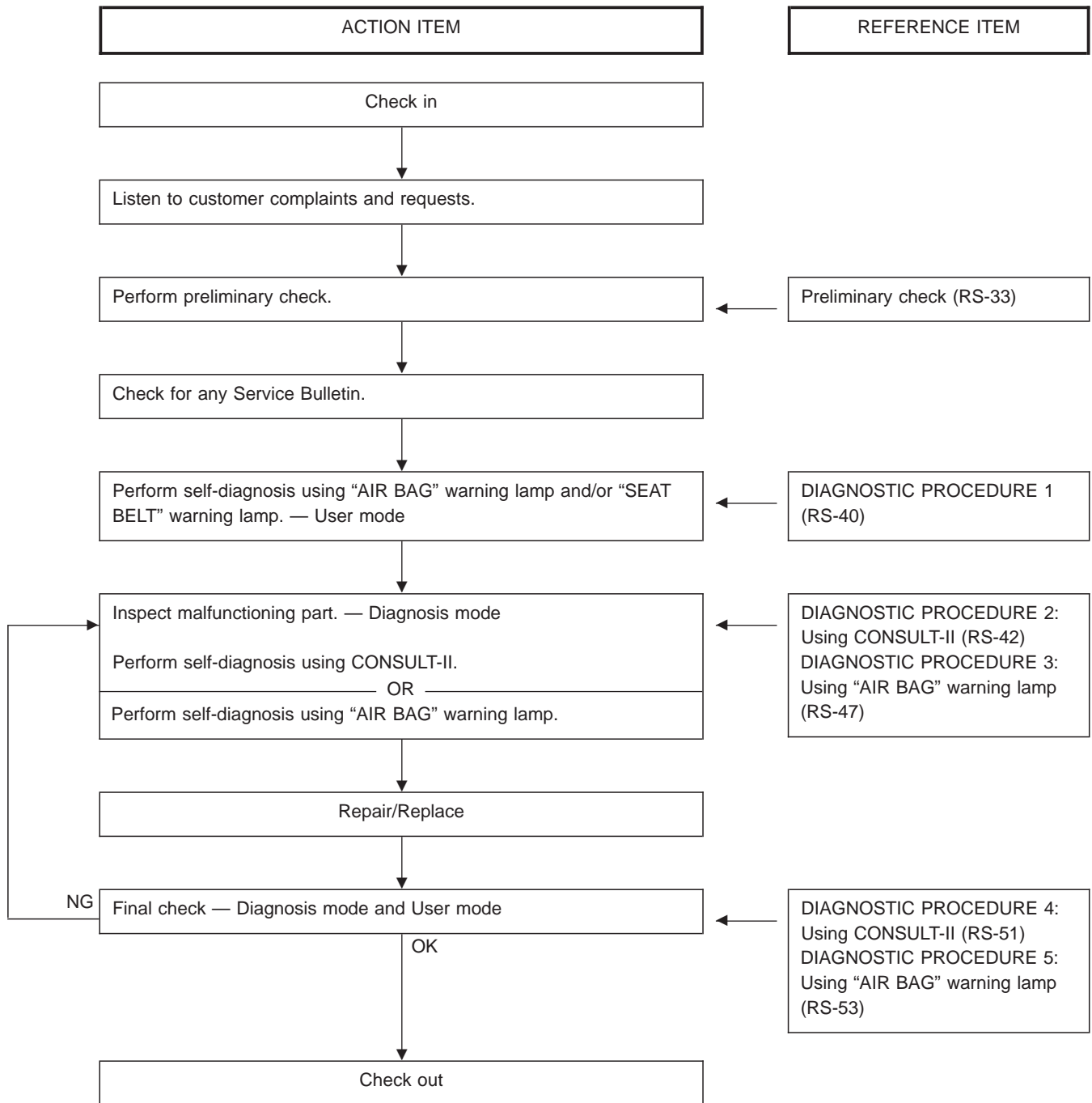

TROUBLE DIAGNOSES — Supplemental Restraint System (SRS)

Schematic

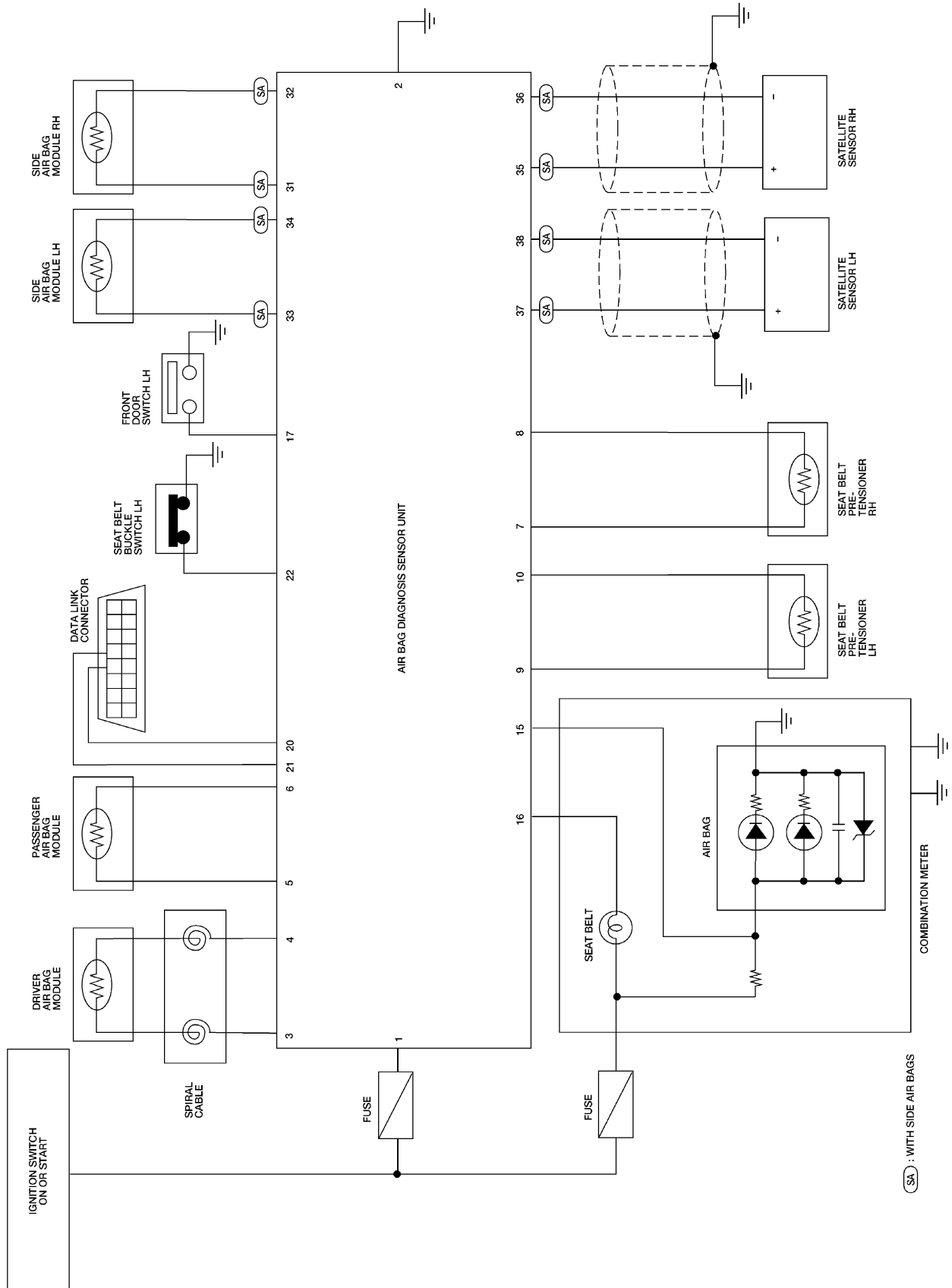

GI
MA
EM
LC
EC
FE
CL
MT
AT
FA
RA
BR
ST
RS
BT
HA
EL
IDX

TROUBLE DIAGNOSES — Supplemental Restraint System (SRS)

Wiring Diagram — SRS —

RS-SRS-01

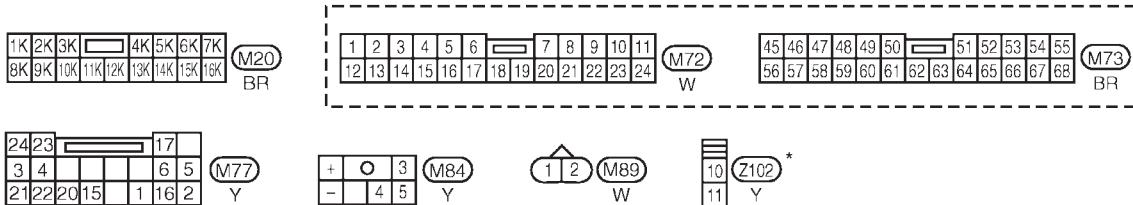
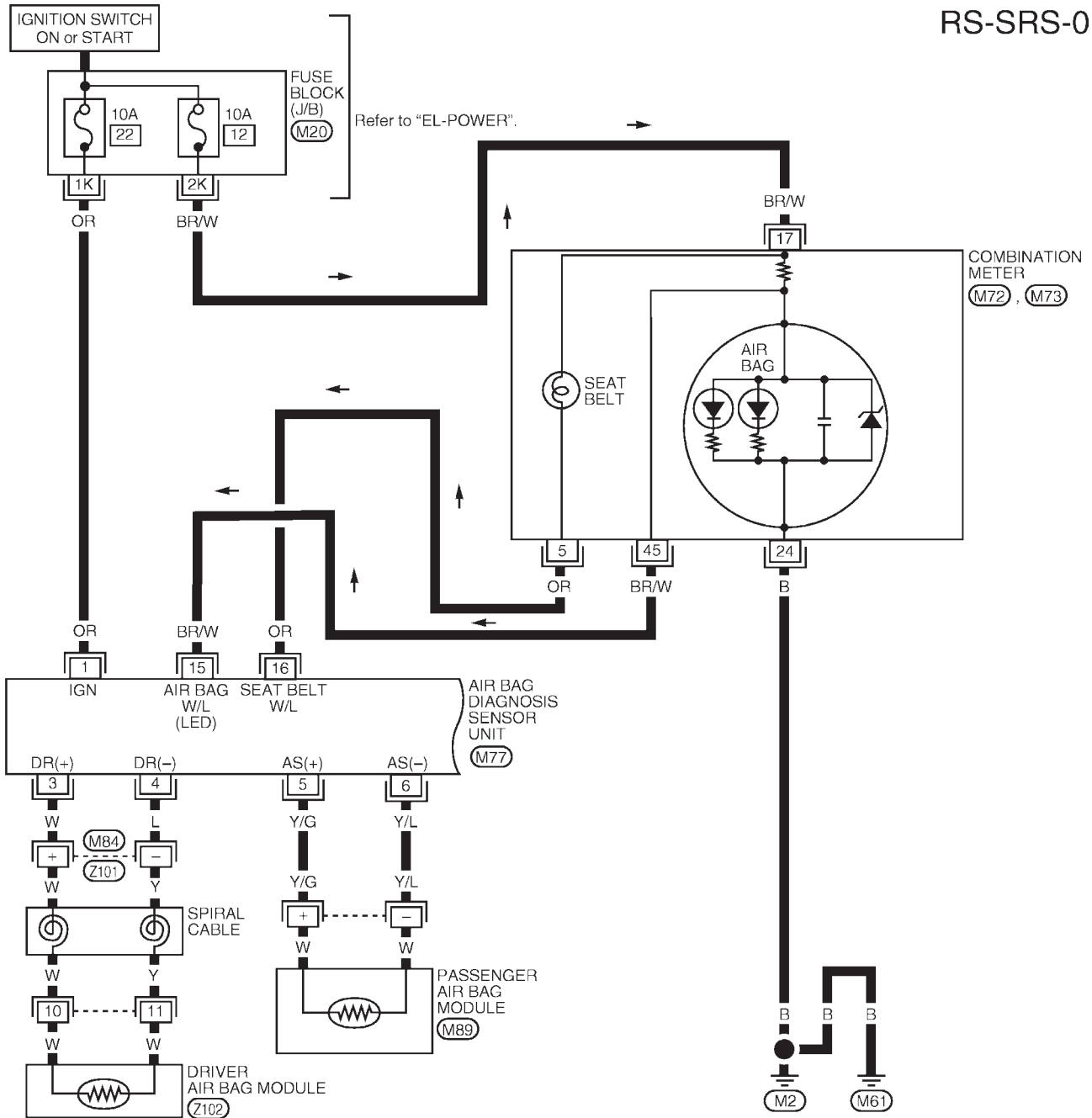

*: This connector is not shown in "HARNES LAYOUT" of EL section.

TROUBLE DIAGNOSES — Supplemental Restraint System (SRS)

Wiring Diagram — SRS — (Cont'd)

RS-SRS-02

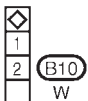
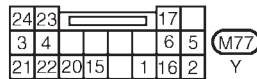
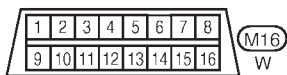
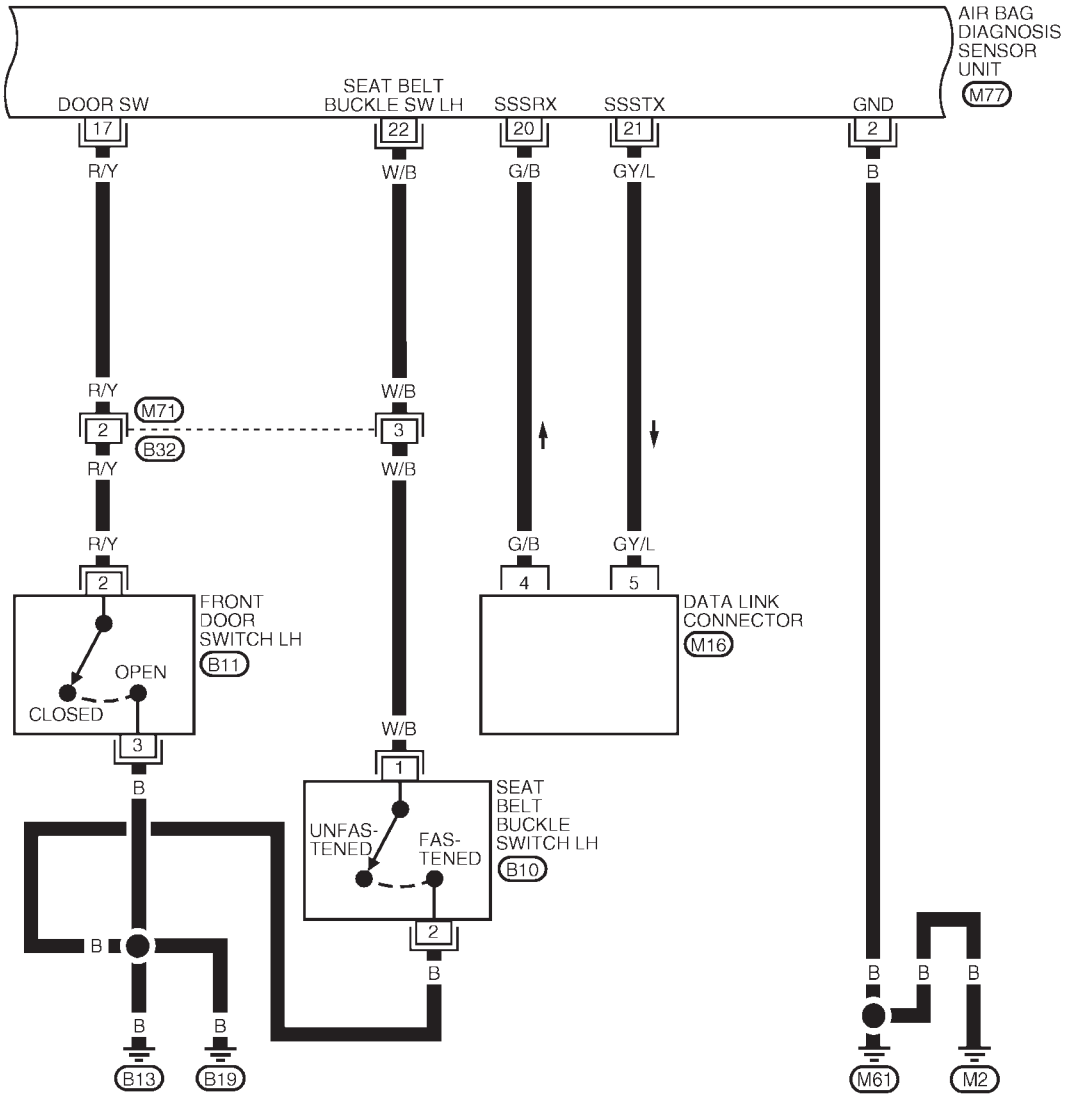

GI
MA
EM
LC
EC
FE
CL
MT
AT
FA
RA
BR
ST
RS
BT
HA
EL
IDX

TROUBLE DIAGNOSES — Supplemental Restraint System (SRS)

Wiring Diagram — SRS — (Cont'd)

RS-SRS-03

◊SA◊ : WITH SIDE AIR BAGS

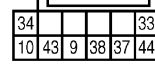
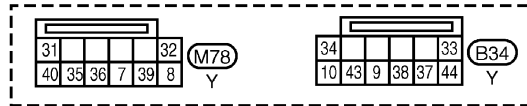
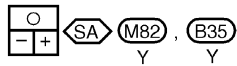
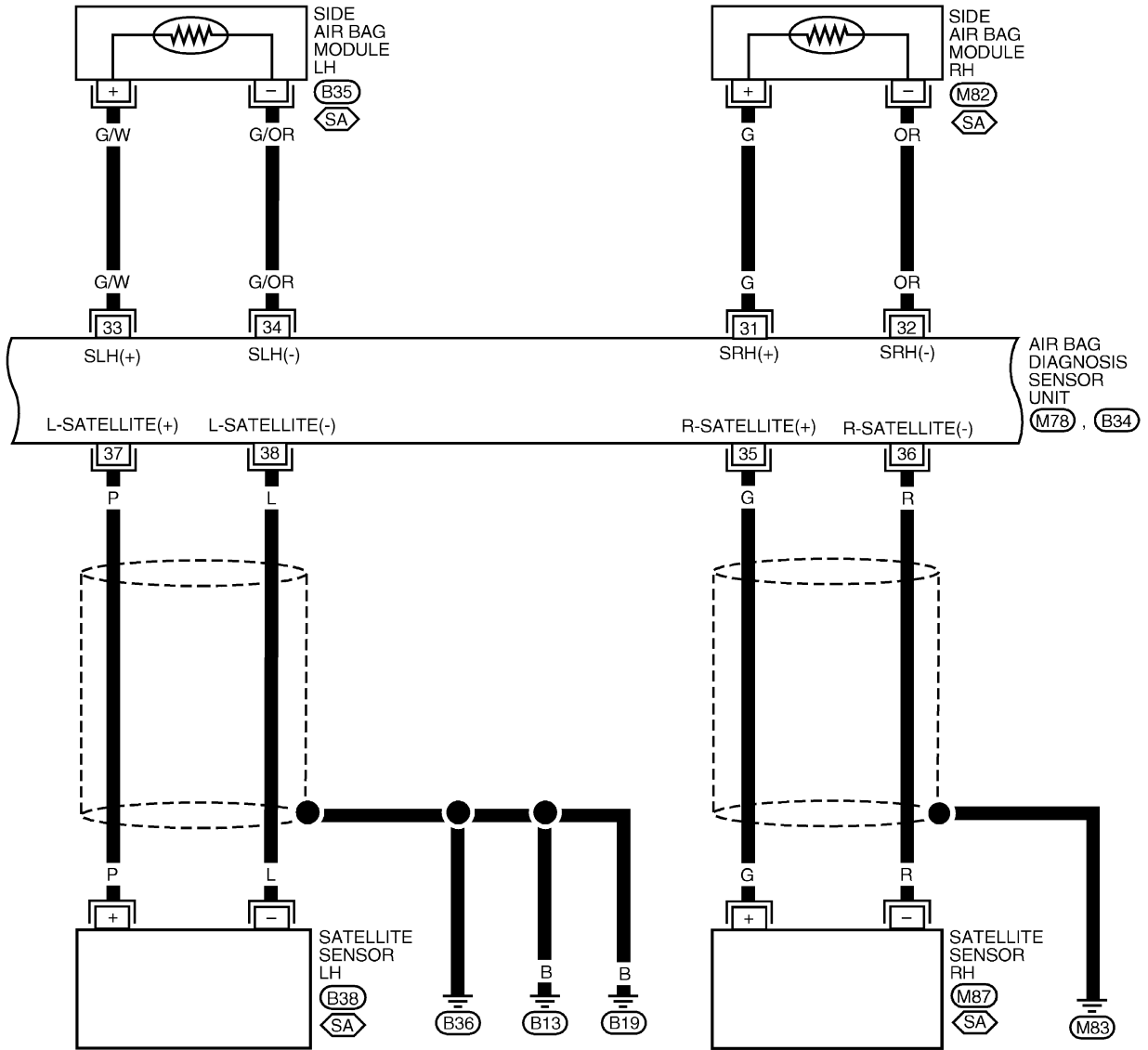

TROUBLE DIAGNOSES — Supplemental Restraint System (SRS)

Wiring Diagram — SRS — (Cont'd)

RS-SRS-04

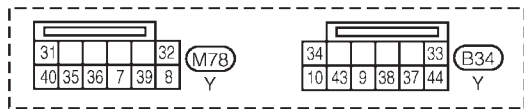
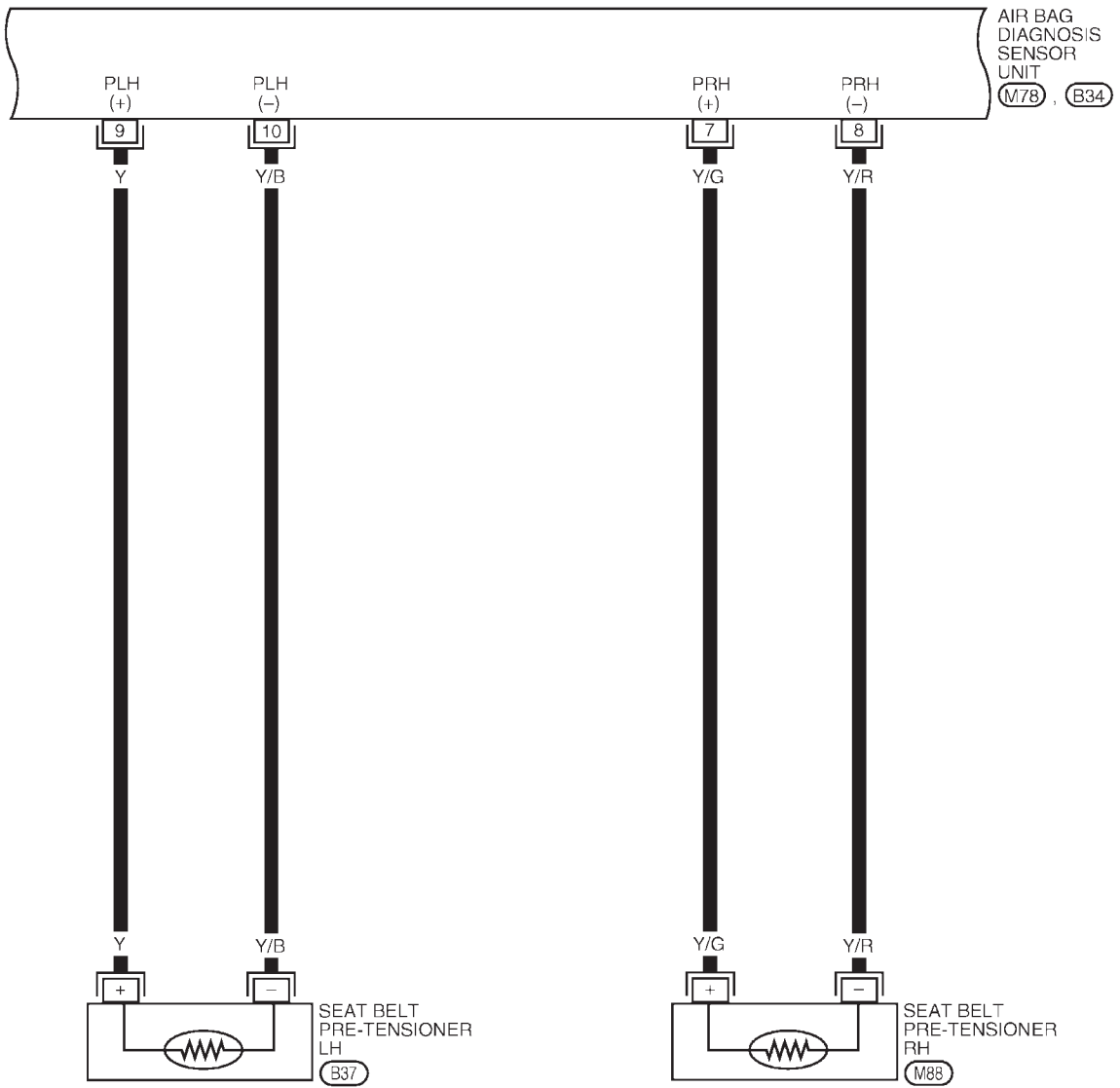

GI
MA
EM
LC
EC
FE
CL
MT
AT
FA
RA
BR
ST
RS
BT
HA
EL
IDX

TROUBLE DIAGNOSES — Supplemental Restraint System (SRS)

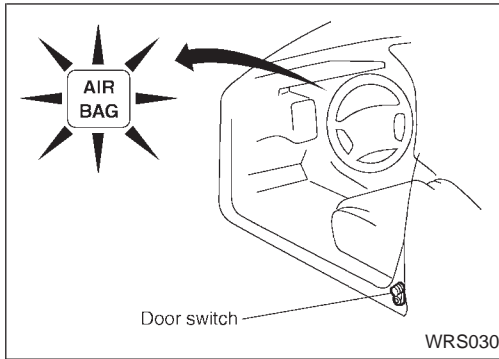

Self-diagnosis

DIAGNOSTIC PROCEDURE 1

Checking SRS operation by using "AIR BAG" warning lamp — User mode

1. After turning ignition switch from "OFF" to "ON", "AIR BAG" warning lamp operates.
2. Compare "AIR BAG" warning lamp operation to the chart below.

"AIR BAG" warning lamp operation — User mode —	SRS condition	Reference item
<p>MRS095A</p>	No malfunction is detected. No further action is necessary.	—
<p>MRS096A</p>	The system is malfunctioning and needs to be repaired as indicated.	Go to DIAGNOSTIC PROCEDURE 2 or 3 (RS-42 or 47).
<p>MRS097A</p>	Air bag is deployed. Air bag fuse, diagnosis sensor unit or harness is malfunctioning and needs to be repaired.	Go to COLLISION DIAGNOSIS (RS-64). Go to DIAGNOSTIC PROCEDURE 9 (RS-60).
<p>MRS098A</p>	One of the following has occurred and needs to be repaired. <ul style="list-style-type: none"> ● Meter fuse is blown. ● "AIR BAG" warning lamp circuit has open or short. ● Diagnosis sensor unit is malfunctioning. 	Go to DIAGNOSTIC PROCEDURE 10 (RS-60).

NOTE:

If "AIR BAG" warning lamp operates differently from the operations shown above, refer to "AIR BAG" warning lamp operation — Diagnosis mode —, DIAGNOSTIC PROCEDURE 3 (step 4), RS-47.

TROUBLE DIAGNOSES — Supplemental Restraint System (SRS)

Self-diagnosis (Cont'd)

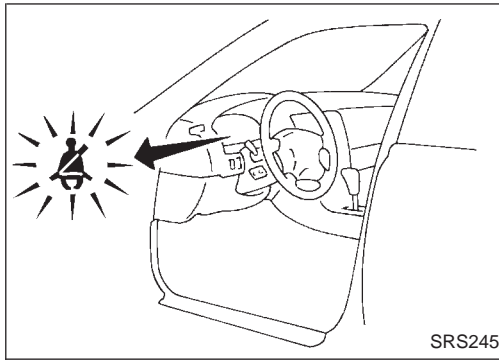

Checking seat belt pre-tensioner operation by using “SEAT BELT” warning lamp — User mode

1. After turning ignition switch from “OFF” to “ON”, “SEAT BELT” warning lamp operates.
2. Compare “SEAT BELT” warning lamp operation to the chart below.

“SEAT BELT” warning lamp operation	SRS condition	Reference item
<ul style="list-style-type: none"> ● After driver’s seat belt has been fastened. <p style="text-align: right;">MRS095A</p>	No malfunction is detected. No further action is necessary.	—
<ul style="list-style-type: none"> ● When driver’s seat belt has not been fastened. <p style="text-align: right;">SRS086</p>		
<ul style="list-style-type: none"> ● After driver’s seat belt has been fastened. <p style="text-align: right;">MRS096A</p>	<ul style="list-style-type: none"> ● Seat belt pre-tensioner circuit is opened, or ● Seat belt pre-tensioner power supply or ground circuit is shorted. 	<ul style="list-style-type: none"> ● If CONSULT-II is available, go to DIAGNOSTIC PROCEDURE 2 (RS-42). ● If CONSULT-II is not available, repair the system as follows.* <ol style="list-style-type: none"> 1. Visually check the wiring harness connections. 2. Replace driver’s and front passenger seat belt assemblies. (Before disposing, they must be deactivated.) 3. Replace diagnosis sensor unit. 4. Replace air bag harness.
<ul style="list-style-type: none"> ● When driver’s seat belt has not been fastened. <p style="text-align: right;">SRS344</p>		
<ul style="list-style-type: none"> ● When driver’s seat belt is fastened. <p style="text-align: right;">MRS097A</p>	Seat belt pre-tensioner (and air bag) is deployed.	Go to COLLISION DIAGNOSIS (RS-64).
	Seat belt buckle switch, harness, combination meter assembly, diagnosis sensor unit are malfunctioning and need to be repaired.	Go to DIAGNOSTIC PROCEDURE 12 (RS-62).
<p style="text-align: right;">MRS098A</p>	Meter fuse, diagnosis sensor unit or “SEAT BELT” warning lamp circuit is shorted or open and needs to be repaired.	Go to DIAGNOSTIC PROCEDURE 13 (RS-63).

* Follow the procedures in numerical order when repairing malfunctioning parts. Confirm whether malfunction is eliminated using the seat belt warning lamp each time repair is finished. If malfunction is still observed, proceed to the next step. When malfunction is eliminated, further repair work is not required.

GI
MA
EM
LC
EC
FE
CL
MT
AT
FA
RA
BR
ST
RS
BT
HA
EL
IDX

TROUBLE DIAGNOSES — Supplemental Restraint System (SRS)

Self-diagnosis (Cont'd)

DIAGNOSTIC PROCEDURE 2 (CONSULT-II) with CONSULT-II Inspecting SRS malfunctioning parts by using CONSULT-II — Diagnosis mode

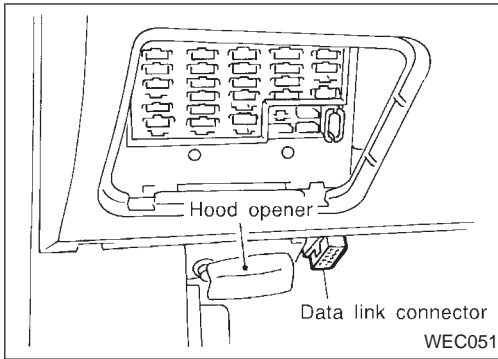

1. Turn ignition switch "OFF".
2. Connect "CONSULT-II" to Data link connector.

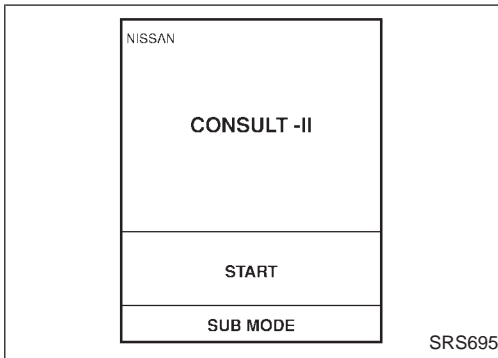

3. Turn ignition switch "ON".
4. Touch "START".

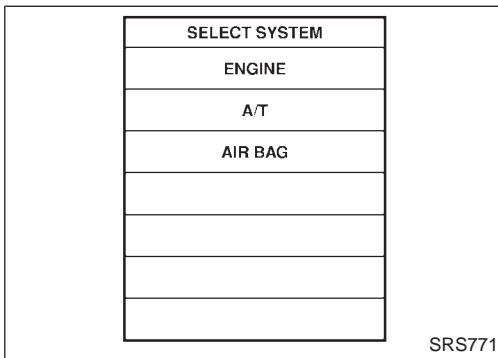

5. Touch "AIRBAG".

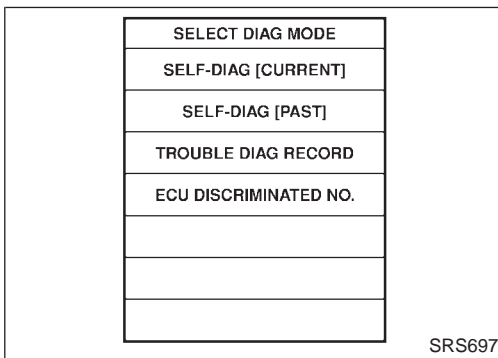

6. Touch "SELF-DIAG [CURRENT]".

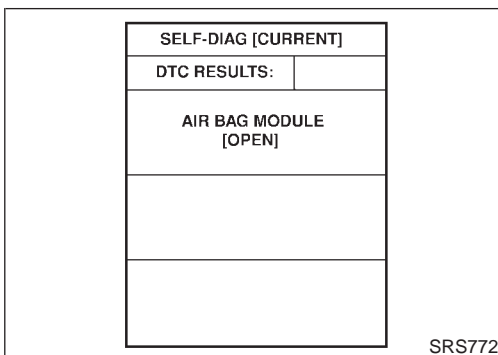

7. Diagnostic codes are displayed on "SELF-DIAG [CURRENT]".

TROUBLE DIAGNOSES — Supplemental Restraint System (SRS)

Self-diagnosis (Cont'd)

SELF-DIAG [CURRENT]	
DTC RESULTS:	
NO DTC IS DETECTED. FURTHER TESTING MAY BE REQUIRED.	

SRS701

If no malfunction is detected on “SELF-DIAG [CURRENT]” even though malfunction is detected in DIAGNOSTIC PROCEDURE 1, go to DIAGNOSTIC PROCEDURE 6, page RS-55, to diagnose the following situations:

- Self-diagnostic result “SELF-DIAG [PAST]” (previously stored in the memory) might not be erased after repair.
- The SRS system malfunctions intermittently.

8. Touch “PRINT”.
9. Compare diagnostic codes to the CONSULT-II DIAGNOSTIC CODE CHART, page RS-44.
10. Touch “BACK” key of CONSULT-II until SELECT SYSTEM appears in order to return to User mode from Diagnosis mode, then turn off CONSULT-II.
11. Turn ignition switch “OFF”, then disconnect CONSULT-II and both battery cables.
12. Repair the system as outlined by the “Repair order” in CONSULT-II DIAGNOSTIC CODE CHART, that corresponds to the self-diagnostic result. For replacement procedure of component parts, refer to RS-16.
13. After repairing the system, go to DIAGNOSTIC PROCEDURE 4 for final checking, page RS-51.

GI

MA

EM

LC

EC

FE

CL

MT

AT

FA

RA

BR

ST

RS

BT

HA

EL

IDX

TROUBLE DIAGNOSES — Supplemental Restraint System (SRS)

Self-diagnosis (Cont'd)

CONSULT-II DIAGNOSTIC CODE CHART (“SELF-DIAG [CURRENT]”)

Diagnostic item	Explanation	Repair order Recheck SRS at each replacement.
NO DTC IS DETECTED	When malfunction is indicated by the “AIR BAG” warning lamp in User mode	<ul style="list-style-type: none"> ● Low battery voltage (Less than 9V)
		<ul style="list-style-type: none"> ● Self-diagnostic result “SELF-DIAG [PAST]” (previously stored in the memory) might not be erased after repair. ● Intermittent malfunction has been detected in the past.
	● No malfunction is detected.	● Go to DIAGNOSTIC PROCEDURE 4 (RS-51).
AIRBAG MODULE [OPEN]	● Driver's air bag module circuit is open. (including the spiral cable)	1. Visually check the wiring harness connection. 2. Replace the harness if it has visible damage.
AIRBAG MODULE [VB-SHORT]	● Driver's air bag module circuit is shorted to some power supply circuit. (including the spiral cable)	3. Replace the spiral cable. 4. Replace driver's air bag module.
AIRBAG MODULE [GND-SHORT]	● Driver's air bag module circuit is shorted to ground. (including the spiral cable)	(Before disposal of it, it must be deployed.)
AIRBAG MODULE [SHORT]	● Driver's air bag module circuits are shorted to each other.	5. Replace the diagnosis sensor unit. 6. Replace the related harness.
ASSIST A/B MODULE [VB-SHORT]	● Front passenger air bag module circuit is shorted to some power supply circuit.	1. Visually check the wiring harness connection. 2. Replace the harness if it has visible damage.
ASSIST A/B MODULE [OPEN]	● Front passenger air bag module circuit is open.	3. Replace front passenger air bag module.
ASSIST A/B MODULE [GND-SHORT]	● Front passenger air bag module circuit is shorted to ground.	(Before disposal of it, it must be deployed.)
ASSIST A/B MODULE [SHORT]	● Front passenger air bag module circuits are shorted to each other.	4. Replace the diagnosis sensor unit. 5. Replace the related harness.
SIDE MODULE LH [OPEN]	● Side air bag module (LH) circuit is open.	1. Visually check the wiring harness connection. 2. Replace the harness if it has visible damage.
SIDE MODULE LH [VB-SHORT]	● Side air bag module (LH) circuit is shorted to some power supply circuits.	3. Replace side air bag module (LH).
SIDE MODULE LH [GND-SHORT]	● Side air bag module (LH) circuit is shorted to ground.	(Before disposal, it must be deployed.)
SIDE MODULE LH [SHORT]	● Side air bag module (LH) circuits are shorted to each other.	4. Replace the diagnosis sensor unit. 5. Replace the related harness.

TROUBLE DIAGNOSES — Supplemental Restraint System (SRS)

Self-diagnosis (Cont'd)

Diagnostic item	Explanation	Repair order Recheck SRS at each replacement.	
SIDE MODULE RH [OPEN]	● Side air bag module (RH) circuit is open.	<ol style="list-style-type: none"> 1. Visually check the wiring harness connection. 2. Replace the harness if it has visible damage. 3. Replace side air bag module (RH). (Before disposal, it must be deployed.) 4. Replace the diagnosis sensor unit. 5. Replace the related harness. 	GI
SIDE MODULE RH [VB-SHORT]	● Side air bag module (RH) circuit is shorted to some power supply circuits.		MA
SIDE MODULE RH [GND-SHORT]	● Side air bag module (RH) circuit is shorted to ground.		EM
SIDE MODULE RH [SHORT]	● Side air bag module (RH) circuits are shorted to each other.		LC
SATELLITE SENS LH [UNIT FAIL] SATELLITE SENS LH [COMM FAIL]	● Satellite sensor (LH)	<ol style="list-style-type: none"> 1. Visually check the wiring harness connection. 2. Replace the harness if it has visible damage. 3. Replace the satellite sensor (LH). 4. Replace the diagnosis sensor unit. 5. Replace the related harness. 	EC
			FE
SATELLITE SENS RH [UNIT FAIL] SATELLITE SENS RH [COMM FAIL]	● Satellite sensor (RH)	<ol style="list-style-type: none"> 1. Visually check the wiring harness connection. 2. Replace the harness if it has visible damage. 3. Replace the satellite sensor (RH). 4. Replace the diagnosis sensor unit. 5. Replace the related harness. 	CL
			MT
PRE-TEN FRONT LH [OPEN/VB-SHORT]	● The circuit for front LH pre-tensioner is open or shorted to some power supply circuit.	<ol style="list-style-type: none"> 1. Visually check the wiring harness connections. 2. Replace the harness if it has visible damage. 3. Replace the driver's seat belt. (Before disposing, it must be deactivated.) 4. Replace the diagnosis sensor unit. 5. Replace the related harness. 	AT
PRE-TEN FRONT LH [GND-SHORT]	● The circuit for front LH pre-tensioner is shorted to ground.		FA
PRE-TEN FRONT RH [OPEN/VB-SHORT]	● The circuit for front RH passenger pre-tensioner is open or shorted to some power supply circuit.	<ol style="list-style-type: none"> 1. Visually check the wiring harness connections. 2. Replace the harness if it has visible damage. 3. Replace the front passenger seat belt. (Before disposing, it must be deactivated.) 4. Replace the diagnosis sensor unit. 5. Replace the related harness. 	RA
PRE-TEN FRONT RH [GND-SHORT]	● The circuit for front RH passenger pre-tensioner is shorted to ground.		BR
			ST
			RS
			BT
			HA
			EL
			IDX

TROUBLE DIAGNOSES — Supplemental Restraint System (SRS)

Self-diagnosis (Cont'd)

Diagnostic item	Explanation	Repair order Recheck SRS at each replacement.
CONTROL UNIT	<ul style="list-style-type: none"> ● Low battery voltage (less than 9V) 	Go to DIAGNOSTIC PROCEDURE 4 (Page RS-51) after charging battery. (Do not replace the diagnosis sensor unit)
	<ul style="list-style-type: none"> ● Diagnosis sensor unit is malfunctioning. 	<ol style="list-style-type: none"> 1. Visually check the wiring harness connections. 2. Replace the diagnosis sensor unit.

* Follow the procedures in numerical order when repairing malfunctioning parts. Confirm whether malfunction is eliminated using the air bag warning lamp or CONSULT-II each time repair is finished. If malfunction is still observed, proceed to the next step. When malfunction is eliminated, further repair work is not required.

TROUBLE DIAGNOSES — Supplemental Restraint System (SRS)

Self-diagnosis (Cont'd)

DIAGNOSTIC PROCEDURE 3 (without CONSULT-II)

Inspecting SRS malfunctioning parts by using "AIR BAG" warning lamp — Diagnosis mode

NOTE:

SRS will not enter Diagnosis mode if no malfunction is detected in User mode.

1. Open driver's door.
2. Turn ignition switch from "OFF" to "ON".
3. Press driver's door switch at least 5 times within 7 seconds after turning ignition switch "ON".
SRS is now in Diagnosis mode.
4. "AIR BAG" warning lamp operates in Diagnosis mode as follows:

NOTE:

If SRS does not enter Diagnosis mode even though malfunction is detected in User mode, go to DIAGNOSTIC PROCEDURE 11, page RS-61.

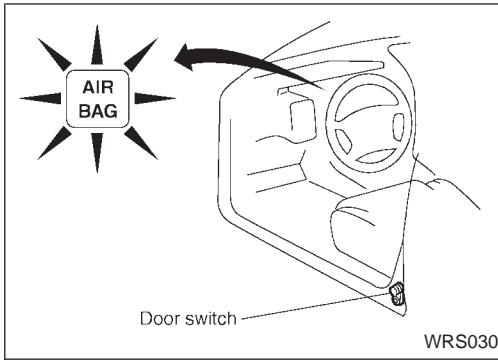

No.	"AIR BAG" warning lamp flash pattern — Diagnosis mode —	SRS condition
1	<p style="text-align: right;">(a) through (b) are repeated.</p> <p style="text-align: right;">SRS333</p>	<ul style="list-style-type: none"> ● Diagnosis results (previously stored in the memory) might not be erased after repair. ● Intermittent malfunction has been detected in the past. Go to DIAGNOSTIC PROCEDURE 7 (RS-55).
2	<p style="text-align: right;">(a) through (d) are repeated.</p> <p>(b) — Driver and passenger air bag marker (For identifying driver and/or passenger air bag malfunctioning)</p> <p>(d) — Indicates malfunctioning part. The number of flash varies with malfunctioning part (0.5 sec. ON and 0.5 sec. OFF is counted as one flash.)</p> <p style="text-align: right;">SRS341</p>	<p>The system is malfunctioning and needs to be repaired.</p>
3	<p style="text-align: right;">(a) through (f) are repeated.</p> <p>(b), (c), (d) — Side air bag marker (For identifying side air bag malfunctioning)</p> <p>(f) — Indicates malfunctioning part. The number of flash varies with malfunctioning part (0.5 sec. ON and 0.5 sec. OFF is counted as one flash.)</p> <p style="text-align: right;">SRS342-A</p>	

TROUBLE DIAGNOSES — Supplemental Restraint System (SRS)

Self-diagnosis (Cont'd)

5. Malfunctioning part is indicated by the number of flashes (part Ⓐ or Ⓕ). Compare the number of flashes to AIR BAG WARNING LAMP FLASH CODE CHART, page RS-47, and locate malfunctioning part.
6. Turn ignition switch "OFF", and disconnect both battery cables.
7. Repair the system as outlined by the "Repair order" in AIR BAG WARNING LAMP FLASH CODE CHART that corresponds to the flash code. For replacement procedure of component parts, refer to RS-16.
8. After repairing the system, go to DIAGNOSTIC PROCEDURE 5, page RS-53.

AIR BAG WARNING LAMP FLASH CODE CHART (DIAGNOSIS MODE)

<ul style="list-style-type: none"> ● Diagnosis results (previously stored in the memory) might not be erased after repair. ● Intermittent malfunction has been detected in the past. 	<p style="text-align: center;">Flash pattern</p> <p style="text-align: right;">Ⓐ through Ⓑ are repeated.</p> <p style="text-align: right;">SRS333</p> <p>Repair order</p> <ul style="list-style-type: none"> ● Go to DIAGNOSTIC PROCEDURE 7 (RS-55).
<p>The driver's air bag module circuit is malfunctioning. (Ⓓ: 2 flashes)</p>	<p style="text-align: center;">Flash pattern</p> <p style="text-align: right;">Ⓐ through Ⓓ are repeated. Ⓓ — Two flashes indicate malfunctioning driver's air bag module circuit.</p> <p style="text-align: right;">SRS334</p> <p>Repair order ("Recheck SRS at each replacement.")</p> <ol style="list-style-type: none"> 1. Visually check the wiring harness connection. 2. Replace the harness if it has visible damage. 3. Replace the spiral cable. 4. Replace driver's air bag module. (Before disposal, it must be deployed.) 5. Replace the diagnosis sensor unit. 6. Replace the related harness.

TROUBLE DIAGNOSES — Supplemental Restraint System (SRS)

Self-diagnosis (Cont'd)

<p>The diagnosis sensor unit is malfunctioning. (d): 7 flashes)</p>	<div style="text-align: center; border-bottom: 1px solid black; margin-bottom: 5px;">Flash pattern</div> <p style="text-align: right;">(a) through (d) are repeated. (d) — Seven flashes indicate malfunctioning diagnosis sensor unit.</p> <p style="text-align: right;">SRS335</p>	GI MA EM LC EC FE CL MT AT FA RA BR ST BT HA EL IDX
<p>Repair order ("Recheck SRS at each replacement.")</p> <ol style="list-style-type: none"> 1. Visually check the wiring harness connections. 2. Replace the harness if it has visible damage. 3. Replace the diagnosis sensor unit. 4. Replace the related harness. 		
<p>The front passenger air bag module circuit is malfunctioning. (d): 8 flashes)</p>	<div style="text-align: center; border-bottom: 1px solid black; margin-bottom: 5px;">Flash pattern</div> <p style="text-align: right;">(a) through (d) are repeated. (d) — Eight flashes indicate malfunctioning front passenger air bag module circuit.</p> <p style="text-align: right;">SRS336</p>	
<p>Repair order ("Recheck SRS at each replacement.")</p> <ol style="list-style-type: none"> 1. Visually check the wiring harness connection. 2. Replace the harness if it has visible damage. 3. Replace front passenger air bag module. (Before disposal, it must be deployed.) 4. Replace the diagnosis sensor unit. 5. Replace the related harness. 		
<p>The side air bag module (RH) circuit is malfunctioning. (f): 1 flash)</p>	<div style="text-align: center; border-bottom: 1px solid black; margin-bottom: 5px;">Flash pattern</div> <p style="text-align: right;">(a) through (f) are repeated. (f) — One flash indicates malfunctioning side air bag module (RH) circuit.</p> <p style="text-align: right;">SRS338</p>	
<p>Repair order ("Recheck SRS at each replacement.")</p> <ol style="list-style-type: none"> 1. Visually check the wiring harness connection. 2. Replace the harness if it has visible damage. 3. Replace side air bag module (RH). (Before disposal, it must be deployed.) 4. Replace the diagnosis sensor unit. 5. Replace the related harness. 		

TROUBLE DIAGNOSES — Supplemental Restraint System (SRS)

Self-diagnosis (Cont'd)

<p>The side air bag module (LH) circuit is malfunctioning. (f) : 2 flashes)</p>	<p style="text-align: center;">Flash pattern</p> <p style="text-align: right;">(a) through (f) are repeated. (f) — Two flashes indicate malfunctioning side air bag module (LH) circuit.</p> <p style="text-align: right;">SRS337</p>
<p>Repair order ("Recheck SRS at each replacement.")</p> <ol style="list-style-type: none"> 1. Visually check the wiring harness connection. 2. Replace the harness if it has visible damage. 3. Replace side air bag module (LH). (Before disposal, it must be deployed.) 4. Replace the diagnosis sensor unit. 5. Replace the related harness. 	
<p>The satellite sensor (RH) is malfunctioning. (f) : 3 flashes)</p>	<p style="text-align: center;">Flash pattern</p> <p style="text-align: right;">(a) through (f) are repeated. (f) — Three flashes indicate malfunctioning satellite sensor (RH) circuit.</p> <p style="text-align: right;">SRS340</p>
<p>Repair order ("Recheck SRS at each replacement.")</p> <ol style="list-style-type: none"> 1. Visually check the wiring harness connection. 2. Replace the harness if it has visible damage. 3. Replace the satellite sensor (RH). 4. Replace the diagnosis sensor unit. 5. Replace the related harness. 	
<p>The satellite sensor (LH) is malfunctioning. (f) : 4 flashes)</p>	<p style="text-align: center;">Flash pattern</p> <p style="text-align: right;">(a) through (f) are repeated. (f) — Four flashes indicate malfunctioning satellite sensor (LH) circuit.</p> <p style="text-align: right;">SRS339-A</p>
<p>Repair order ("Recheck SRS at each replacement.")</p> <ol style="list-style-type: none"> 1. Visually check the wiring harness connection. 2. Replace the harness if it has visible damage. 3. Replace the satellite sensor (LH). 4. Replace the diagnosis sensor unit. 5. Replace the related harness. 	

* Follow the procedures in numerical order when repairing malfunctioning parts. Confirm whether malfunction is eliminated using the air bag warning lamp (in User mode) or CONSULT-II each time repair is finished. If malfunction is still observed, proceed to the next step. When malfunction is eliminated, further repair work is not required.

TROUBLE DIAGNOSES — Supplemental Restraint System (SRS)

Self-diagnosis (Cont'd)

DIAGNOSTIC PROCEDURE 4 (CONSULT-II) with CONSULT-II) Final checking after repairing SRS by using CONSULT-II — Diagnosis mode

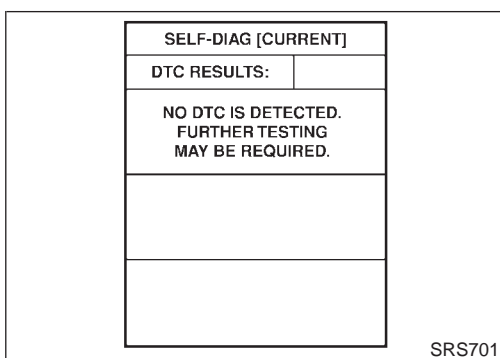
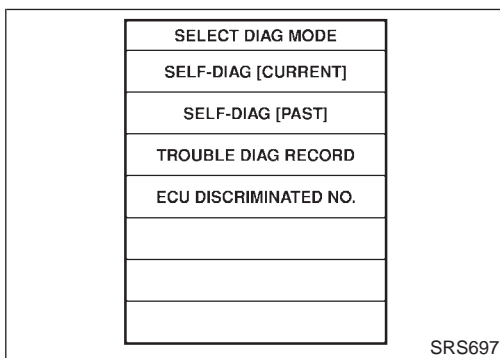
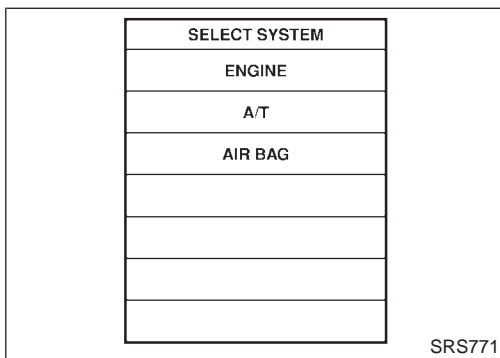
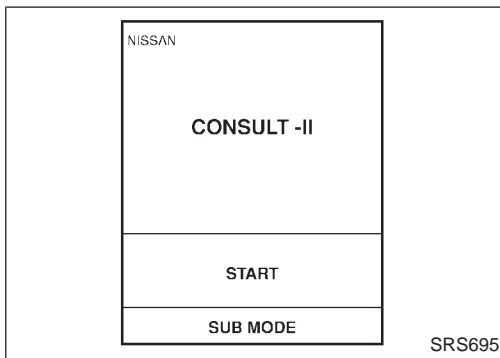
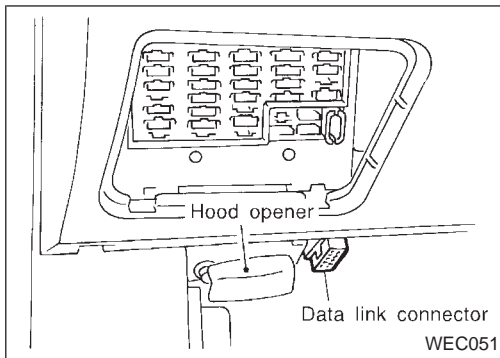

1. After repairing SRS, connect both battery cables.
2. Connect CONSULT-II to Data link connector.
3. Turn ignition switch from "OFF" to "ON".

4. Touch "START".

5. Touch "AIRBAG".

6. Touch "SELF-DIAG [CURRENT]".

7. If no malfunction is detected on "SELF-DIAG [CURRENT]", repair of SRS is completed.
If any malfunction is detected on "SELF-DIAG [CURRENT]", the malfunctioning part is not repaired completely or another malfunctioning part is detected. Go to DIAGNOSTIC PROCEDURE 2, page RS-42, and repair malfunctioning part completely.

GI

MA

EM

LC

EC

FE

CL

MT

AT

FA

RA

BR

ST

RS

BT

HA

EL

IDX

TROUBLE DIAGNOSES — Supplemental Restraint System (SRS)

Self-diagnosis (Cont'd)

SELF-DIAG [CURRENT]	
DTC RESULTS:	
AIR BAG MODULE [OPEN]	
ERASE	

SRS773

SELECT DIAG MODE	
SELF-DIAG [CURRENT]	
SELF-DIAG [PAST]	
TROUBLE DIAG RECORD	
ECU DISCRIMINATED NO.	

SRS697

SELF-DIAG [PAST]	
DTC RESULTS:	
NO DTC IS DETECTED. FURTHER TESTING MAY BE REQUIRED.	

SRS702

8. Touch "ERASE".

NOTE:

Touch "ERASE" to clear the memory of the malfunction ("SELF-DIAG [PAST]").

If the memory of the malfunction is "SELF-DIAG [PAST]" is not erased, the User mode shows the system malfunction by the operation of the warning lamp even if the malfunction is repaired completely.

9. Touch "BACK" key of CONSULT-II to select "SELF-DIAG [PAST]" in the "SELECT DIAG MODE" screen. Touch "SELF-DIAG [PAST]".

10. Check that no malfunction is detected on "SELF-DIAG [PAST]".

11. Touch "BACK" key of CONSULT-II until SELECT SYSTEM appears in order to return to User mode from Diagnosis mode, turn off CONSULT-II, then disconnect CONSULT-II.

12. Turn ignition switch "OFF".

13. Go to DIAGNOSTIC PROCEDURE 1, page RS-40 to check SRS operation by using "AIR BAG" warning lamp with User mode.

TROUBLE DIAGNOSES — Supplemental Restraint System (SRS)

Self-diagnosis (Cont'd)

DIAGNOSTIC PROCEDURE 5 (⊗ without CONSULT-II)

Final checking after repairing SRS by using "AIR BAG" warning lamp — Diagnosis mode and User mode

1. After repairing SRS connect both battery cables.
2. Open driver's door.
3. Turn ignition switch from "OFF" to "ON".
4. "AIR BAG" warning lamp operates in Diagnosis mode as follows:

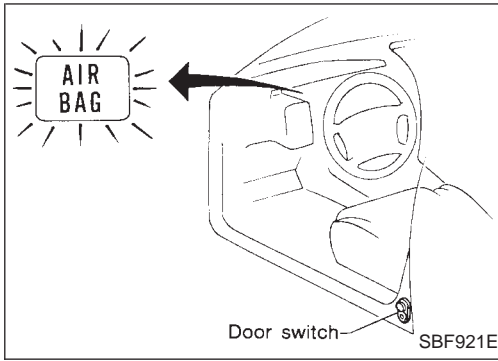

No.	"AIR BAG" warning lamp flash pattern — Diagnosis mode —	SRS condition
1	<p style="text-align: center;">SRS333</p>	<p>(a) through (b) are repeated.</p> <p>No malfunction is detected or repair is completed. No further action is necessary.</p>
2	<p style="text-align: center;">SRS341</p>	<p>(a) through (d) are repeated.</p> <p>(b) — Driver and passenger air bag marker (For identifying driver and/or passenger air bag malfunctioning)</p> <p>(d) — Indicates malfunctioning part. The number of flashes varies with malfunctioning part (0.5 sec. ON and 0.5 sec. OFF is counted as one flash.)</p>
3	<p style="text-align: center;">SRS342-A</p>	<p>(a) through (f) are repeated.</p> <p>(b), (c), (d) — Side air bag marker (For identifying side air bag malfunctioning)</p> <p>(f) — Indicates malfunctioning part. The number of flashes varies with malfunctioning part (0.5 sec. ON and 0.5 sec. OFF is counted as one flash.)</p>

NOTE:

When diagnosis sensor unit is replaced with new one, "AIR BAG" warning lamp will operate in User mode. Checking "AIR BAG" warning lamp operation in Diagnosis mode is not required. Go to step 6.

GI
MA
EM
LC
EC
FE
CL
MT
AT
FA
RA
BR
ST
RS
BT
HA
EL
IDX

TROUBLE DIAGNOSES — Supplemental Restraint System (SRS)

Self-diagnosis (Cont'd)



- If "AIR BAG" warning lamp operates as shown in No. 1 in chart above, turn ignition switch "OFF" to reset from Diagnosis mode to User mode and to erase the memory of the malfunction. Then go to step 6.

If "AIR BAG" warning lamp operates as shown in No. 2 or No. 3 in chart above, the malfunctioning part is not repaired completely, or another malfunctioning part is detected. Go to DIAGNOSTIC PROCEDURE 3, page RS-47, and repair malfunctioning part completely.

- Turn ignition switch "ON". "AIR BAG" warning lamp operates in User mode. Compare "AIR BAG" warning lamp operation to the chart below.

NOTE:

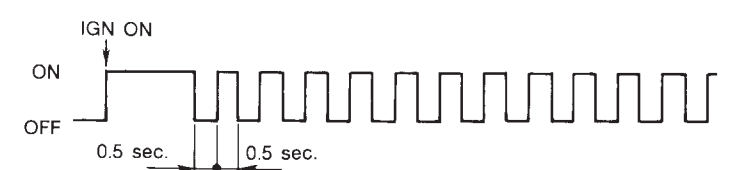
If switching Diagnosis mode to User mode is required while malfunction is being detected, turn ignition switch from "OFF" to "ON". Then press driver's door switch at least 5 times within 7 seconds after turning ignition switch "ON". SRS is now in User mode.

"AIR BAG" warning lamp operation — User mode —	SRS condition	Reference item
 <p>MRS095A</p>	No malfunction is detected. No further action is necessary.	—
 <p>MRS096A</p>	The system is malfunctioning and needs to be repaired as indicated.	Go to DIAGNOSTIC PROCEDURE 2 or 3 (RS-42 or 47).
 <p>MRS097A</p>	Air bag is deployed. Air bag fuse, diagnosis sensor unit or harness is malfunctioning and needs to be repaired.	Go to COLLISION DIAGNOSIS (RS-64). Go to DIAGNOSTIC PROCEDURE 9 (RS-60).
 <p>MRS098A</p>	One of the following has occurred and needs to be repaired. <ul style="list-style-type: none"> ● Meter fuse is blown. ● "AIR BAG" warning lamp circuit has open or short. ● Diagnosis sensor unit is malfunctioning. 	Go to DIAGNOSTIC PROCEDURE 10 (RS-60).

TROUBLE DIAGNOSES — Supplemental Restraint System (SRS)

Self-diagnosis (Cont'd)

DIAGNOSTIC PROCEDURE 6 (Continued from DIAGNOSTIC PROCEDURE 2) (📱 with CONSULT-II)

Inspecting SRS malfunctioning record

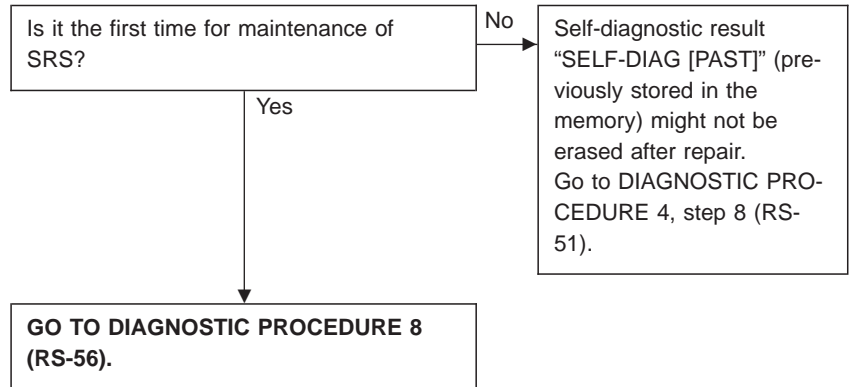

DIAGNOSTIC PROCEDURE 7 (Continued from DIAGNOSTIC PROCEDURE 3) (🕒 without CONSULT-II)

Inspecting SRS malfunctioning record

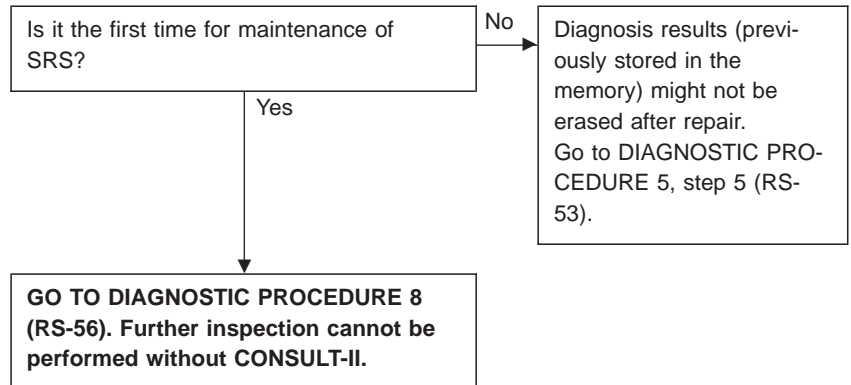

GI
MA
EM
LC
EC
FE
CL
MT
AT
FA
RA
BR
ST
BT
HA
EL
IDX

RS

TROUBLE DIAGNOSES — Supplemental Restraint System (SRS)

Self-diagnosis (Cont'd)

DIAGNOSTIC PROCEDURE 8 (CONSULT-II) with CONSULT-II) Inspecting SRS intermittent malfunction by using CONSULT-II — Diagnosis mode

1. Turn ignition switch "OFF".
2. Connect "CONSULT-II" to Data link connector.

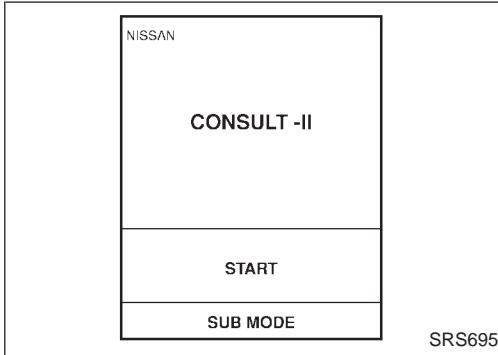
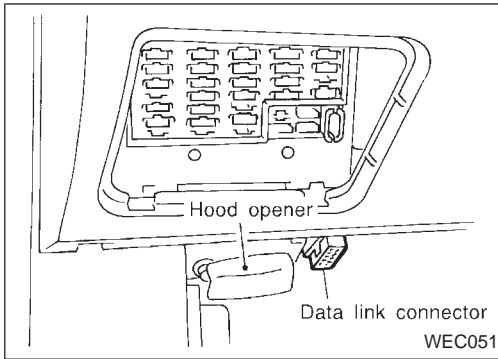

3. Turn ignition switch "ON".
4. Touch "START".

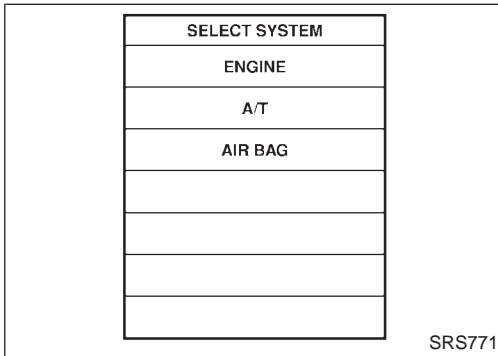

5. Touch "AIRBAG".

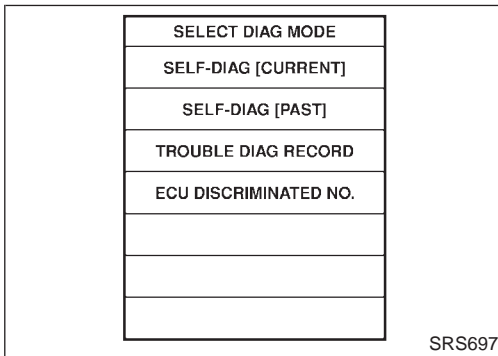

6. Touch "SELF-DIAG [PAST]".

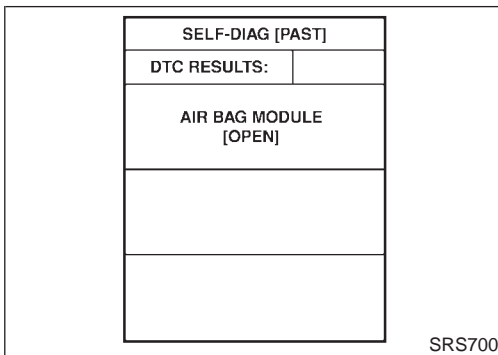

7. If diagnostic codes are displayed on "SELF-DIAG [PAST]", go to step 10.

TROUBLE DIAGNOSES — Supplemental Restraint System (SRS)

Self-diagnosis (Cont'd)

If no malfunction is detected on “SELF-DIAG [PAST]”, touch “BACK” and go back to “SELECT DIAG MODE”.

SELF-DIAG [PAST]	
DTC RESULTS:	
NO DTC IS DETECTED. FURTHER TESTING MAY BE REQUIRED.	

SRS702

SELECT DIAG MODE	
SELF-DIAG [CURRENT]	
SELF-DIAG [PAST]	
TROUBLE DIAG RECORD	
ECU DISCRIMINATED NO.	

SRS697

TROUBLE DIAG RECORD	
DTC RESULTS:	
AIR BAG MODULE [OPEN]	

SRS704

8. Touch “TROUBLE DIAG RECORD”.

NOTE:

With **TROUBLE DIAG RECORD**, diagnosis results previously erased by a reset operation can be displayed.

9. Diagnostic code is displayed on “TROUBLE DIAG RECORD”.

10. Touch “PRINT”.

11. Compare diagnostic codes to the INTERMITTENT MALFUNCTION DIAGNOSTIC CODE CHART, page RS-58.

12. Touch “BACK” key of CONSULT-II until SELECT SYSTEM appears, then turn off CONSULT-II.

13. Turn ignition switch “OFF”, then turn off and disconnect CONSULT-II and both battery cables.

14. Repair the system as outlined by the “Repair order” in INTERMITTENT MALFUNCTION DIAGNOSTIC CODE CHART, that corresponds to the self-diagnostic result. For replacement procedure of component parts, refer to RS-16.

15. Go to DIAGNOSTIC PROCEDURE 4, page RS-51, for final checking.

GI
MA
EM
LC
EC
FE
CL
MT
AT
FA
RA
BR
ST
RS
BT
HA
EL
IDX

TROUBLE DIAGNOSES — Supplemental Restraint System (SRS)

Self-diagnosis (Cont'd)

INTERMITTENT MALFUNCTION DIAGNOSTIC CODE CHART (SELF-DIAG [PAST] or TROUBLE DIAG RECORD)

Diagnostic item	Explanation		Repair order
DTC IS DETECTED	When malfunction is indicated by the "AIR BAG" warning lamp in User mode	<ul style="list-style-type: none"> ● Low battery voltage (Less than 9V) 	<ul style="list-style-type: none"> ● After charging battery go to DIAGNOSTIC PROCEDURE 4, for final checking, page (RS-51).
	<ul style="list-style-type: none"> ● No malfunction is detected. 		<ul style="list-style-type: none"> ● Go to DIAGNOSTIC PROCEDURE 4 (RS-51).
AIRBAG MODULE [OPEN]	<ul style="list-style-type: none"> ● Driver's air bag module circuit is open. (including the spiral cable) 		<ol style="list-style-type: none"> 1. Visually check the wiring harness connection. 2. Replace air bag harness if it has visible damage. 3. If the harness check result is OK, replace driver's air bag module (Before disposal of it, it must be deployed.), diagnosis sensor unit and spiral cable.
AIRBAG MODULE [VB-SHORT]	<ul style="list-style-type: none"> ● Driver's air bag module circuit is shorted to some power supply circuit. (including the spiral cable) 		
AIRBAG MODULE [GND-SHORT]	<ul style="list-style-type: none"> ● Driver's air bag module circuit is shorted to ground. (including the spiral cable) 		
AIRBAG MODULE [SHORT]	<ul style="list-style-type: none"> ● Driver's air bag module circuits are shorted to each other. 		
ASSIST A/B MODULE [VB-SHORT]	<ul style="list-style-type: none"> ● Front passenger air bag module circuit is shorted to some power supply circuit. 		<ol style="list-style-type: none"> 1. Visually check the wiring harness connection. 2. Replace air bag harness if it has visible damage. 3. If the harness check result is OK, replace front air bag module (Before disposal of it, it must be deployed.), and diagnosis sensor unit.
ASSIST A/B MODULE [OPEN]	<ul style="list-style-type: none"> ● Front passenger air bag module circuit is open. 		
ASSIST A/B MODULE [GND-SHORT]	<ul style="list-style-type: none"> ● Front passenger air bag module circuit is shorted to ground. 		
ASSIST A/B MODULE [SHORT]	<ul style="list-style-type: none"> ● Front passenger air bag module circuits are shorted to each other. 		
SIDE MODULE LH [OPEN]	<ul style="list-style-type: none"> ● Side air bag module (LH) circuit is open. 		<ol style="list-style-type: none"> 1. Visually check the wiring harness connection. 2. Replace the harness if it has visible damage. 3. If the harness check is OK, replace the diagnosis sensor unit and side air bag module (LH). (Before disposing the side air bag module (LH), it must be deployed.)
SIDE MODULE LH [VB-SHORT]	<ul style="list-style-type: none"> ● Side air bag module (LH) circuit is shorted to some power supply circuits. 		
SIDE MODULE LH [GND-SHORT]	<ul style="list-style-type: none"> ● Side air bag module (LH) circuit is shorted to ground. 		
SIDE MODULE LH [SHORT]	<ul style="list-style-type: none"> ● Side air bag module (LH) circuits are shorted to each other. 		
SIDE MODULE RH [OPEN]	<ul style="list-style-type: none"> ● Side air bag module (RH) circuit is open. 		<ol style="list-style-type: none"> 1. Visually check the wiring harness connection. 2. Replace the harness if it has visible damage. 3. If the harness check is OK, replace the diagnosis sensor unit and side air bag module (RH). (Before disposing the side air bag module (RH), it must be deployed.)
SIDE MODULE RH [VB-SHORT]	<ul style="list-style-type: none"> ● Side air bag module (RH) circuit is shorted to some power supply circuits. 		
SIDE MODULE RH [GND-SHORT]	<ul style="list-style-type: none"> ● Side air bag module (RH) circuit is shorted to ground. 		
SIDE MODULE RH [SHORT]	<ul style="list-style-type: none"> ● Side air bag module (RH) circuits are shorted to each other. 		

TROUBLE DIAGNOSES — Supplemental Restraint System (SRS) Self-diagnosis (Cont'd)

Diagnostic item	Explanation	Repair order
SATELLITE SENS LH [UNIT FAIL] SATELLITE SENS LH [COMM FAIL]	● Satellite sensor (LH)	1. Visually check the wiring harness connection. 2. Replace the harness if it has visible damage. 3. If the harness check is OK, replace the diagnosis sensor unit and satellite sensor (LH).
SATELLITE SENS RH [UNIT FAIL] SATELLITE SENS RH [COMM FAIL]	● Satellite sensor (RH)	1. Visually check the wiring harness connection. 2. Replace the harness if it has visible damage. 3. If the harness check is OK, replace the diagnosis sensor unit and satellite sensor (RH).
CONTROL UNIT	● Diagnosis sensor unit is malfunctioning.	1. Visually check the wiring harness connection. 2. Replace the harness if it has visible damage. 3. If the harness check is OK, replace the diagnosis sensor unit.

* Intermittent malfunction areas cannot be easily located. For this reason, perform the procedures outlined under the repair order, then make the final system check.

GI
MA
EM
LC
EC
FE
CL
MT
AT
FA
RA
BR
ST
RS
BT
HA
EL
IDX

TROUBLE DIAGNOSES — Supplemental Restraint System (SRS)

Trouble Diagnoses for Air Bag Warning Lamp

DIAGNOSTIC PROCEDURE 9

SYMPTOM: "AIR BAG" warning lamp does not turn off.

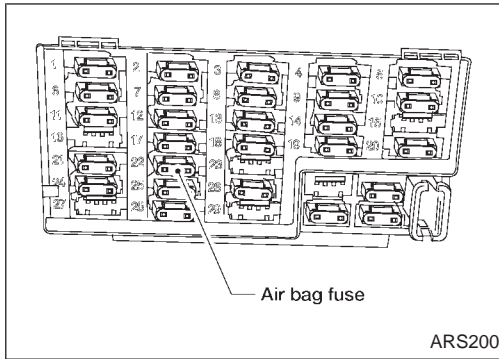

ARS200

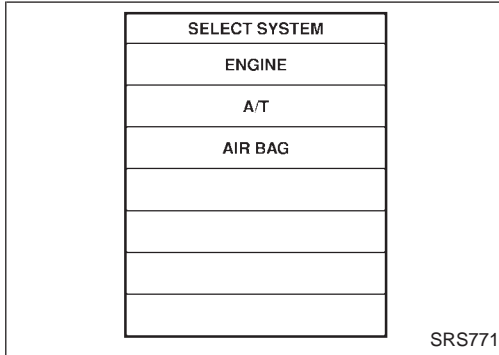

SRS771

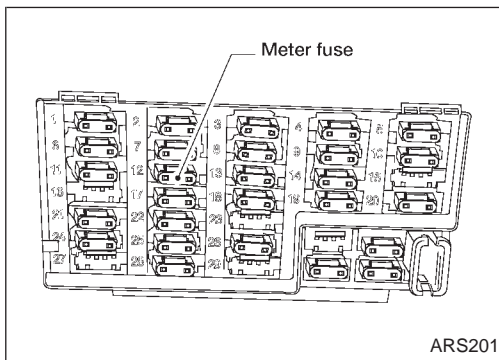
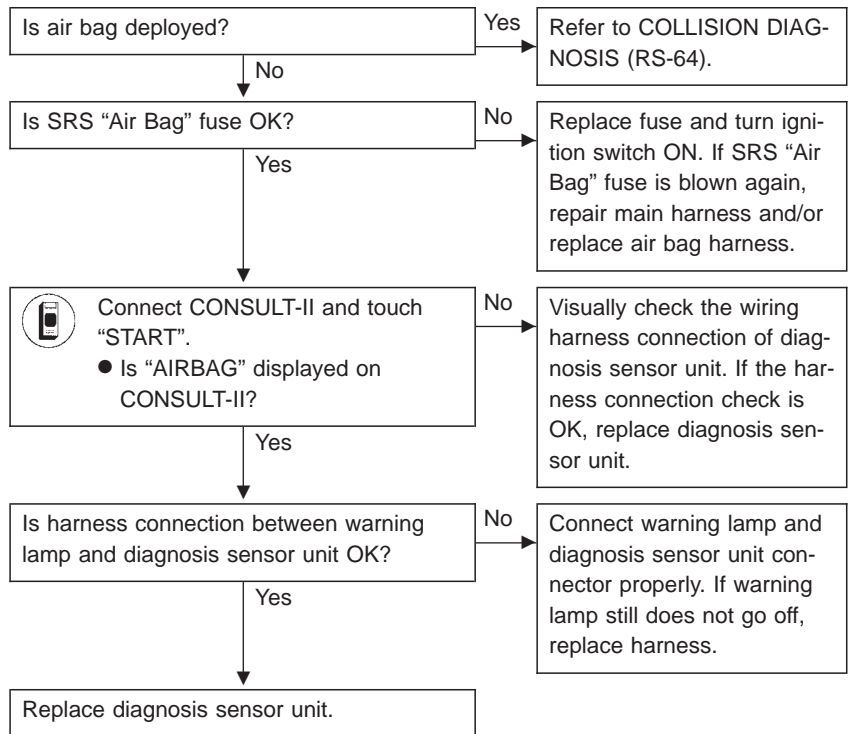

ARS201

DIAGNOSTIC PROCEDURE 10

SYMPTOM: "AIR BAG" warning lamp does not turn on.

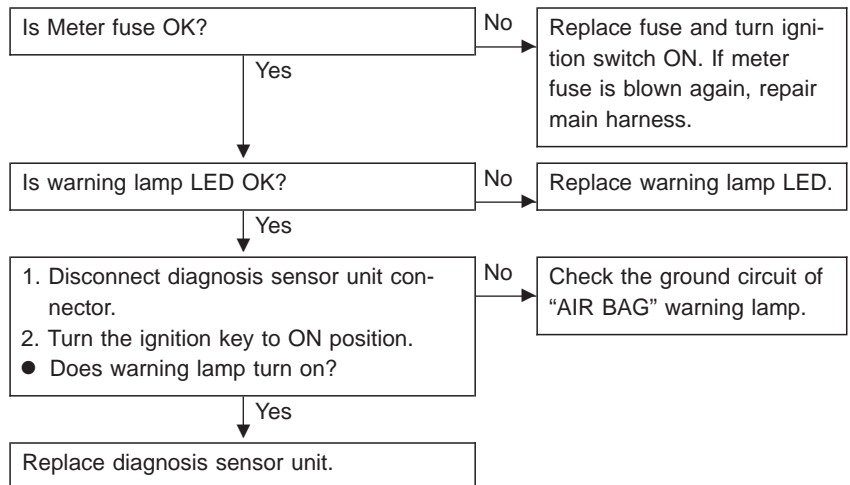

TROUBLE DIAGNOSES — Supplemental Restraint System (SRS)

Trouble Diagnoses for Air Bag Warning Lamp (Cont'd)

DIAGNOSTIC PROCEDURE 11

SYMPTOM: SRS does not enter Diagnosis mode using door switch.

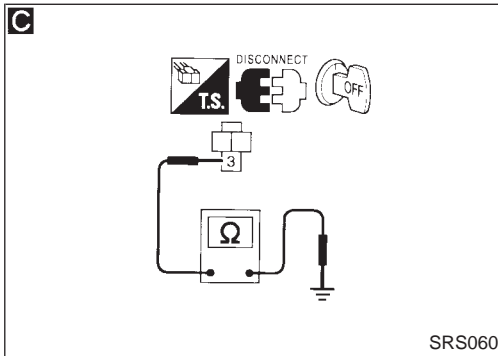
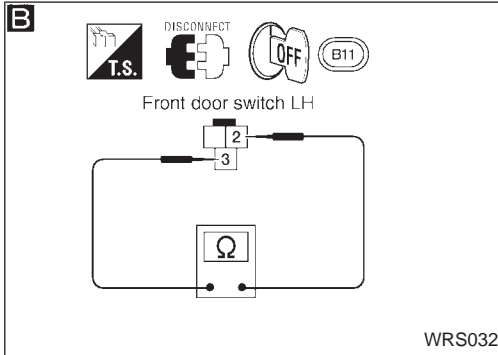
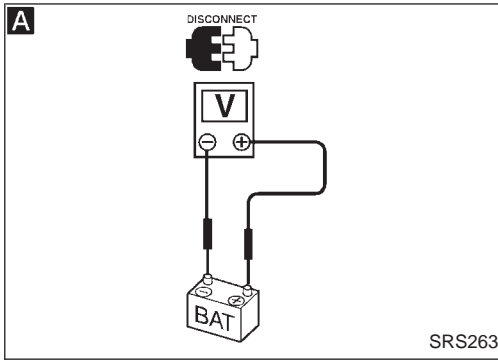

A

Disconnect both battery cables and check battery voltage using circuit tester.

- Is battery voltage more than 9V?

No → Charge battery.

Yes →

B

Remove driver's door switch and check continuity between driver's door switch connector terminals ② and ③ under the following conditions.

Condition	Continuity
Door switch is depressed (Door is closed).	NO
Door switch is released (Door is open).	YES

No → Replace driver's door switch.

Yes →

C

Check harness continuity between driver's door switch connector terminal ③ and body ground.

- Does continuity exist?

No → Replace or repair harness.

Yes →

Replace diagnosis sensor unit.

→

Go to DIAGNOSTIC PROCEDURE 1 (RS-40).

GI
MA
EM
LC
EC
FE
CL
MT
AT
FA
RA
BR
ST
RS
BT
HA
EL
IDX

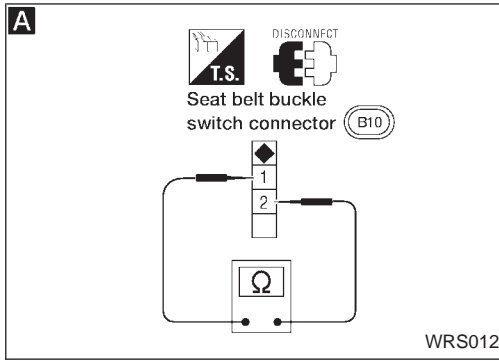

Trouble Diagnosis for Seat Belt Pre-tensioner Warning Lamp DIAGNOSTIC PROCEDURE 12

SYMPTOM: "SEAT BELT" warning lamp does not turn off.

Is the seat belt pre-tensioner (and driver's and passenger's air bags) deployed? Yes

Refer to COLLISION DIAGNOSIS (RS-64).

No

Is driver's seat belt fastened? No

Check "SEAT BELT" warning lamp operation after the seat belt is fastened.

Yes

A Check driver's seat belt buckle switch. NG

1. Disconnect the seat belt buckle switch connector.

2. Check continuity between terminals ① and ②.

Replace the seat belt buckle switch.

Condition of seat belt	Continuity
Unfastened	Yes
Fastened	No

WARNING:
Do not measure resistance with harness side connector.

OK

1. Visually check the wiring harness connection. Yes

2. Replace the diagnosis unit.

3. Fasten the seat belt.

4. Turn ignition switch to ON position.

5. Does the "SEAT BELT" warning lamp illuminate for about 7 seconds and then turn off?

System is OK.

No

1. Replace combination meter assembly. Yes

2. Fasten the seat belt.

3. Turn ignition switch to ON position.

4. Does the "SEAT BELT" warning lamp illuminate for about 7 seconds and then turn off?

System is OK.

No

Replace the main harness and air bag harness.

TROUBLE DIAGNOSES — Supplemental Restraint System (SRS)

Trouble Diagnosis for Seat Belt Pre-tensioner Warning Lamp (Cont'd)

DIAGNOSTIC PROCEDURE 13

SYMPTOM: "SEAT BELT" warning lamp does not turn on.

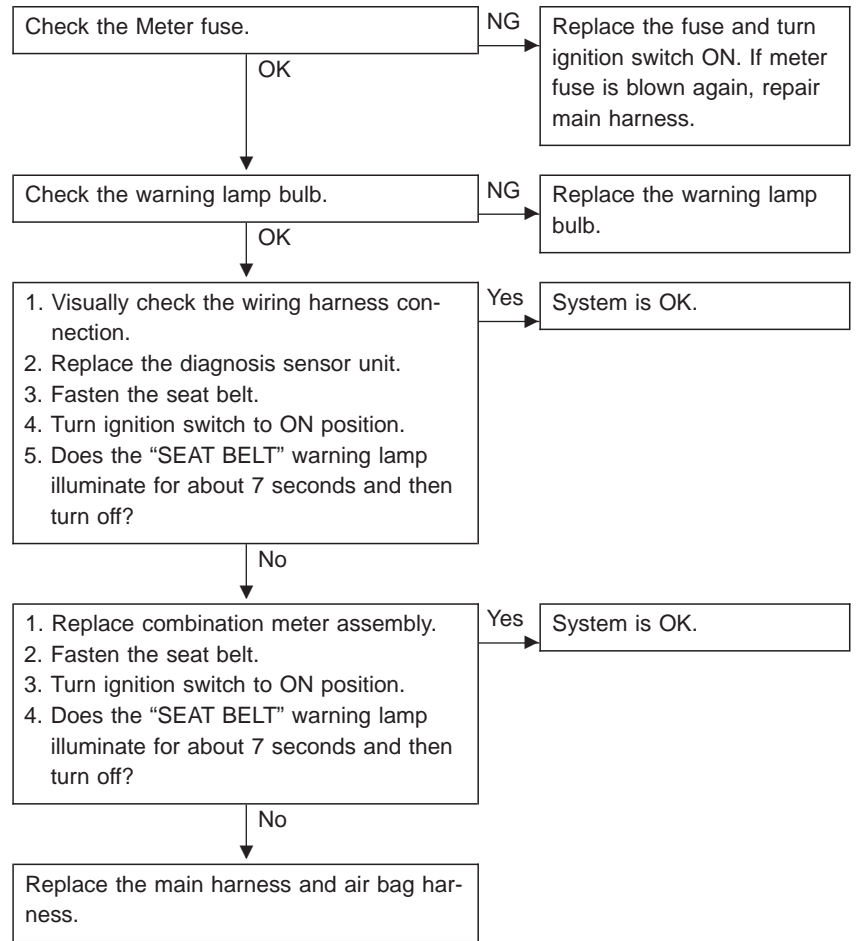

GI
MA
EM
LC
EC
FE
CL
MT
AT
FA
RA
BR
ST
RS
BT
HA
EL
IDX

COLLISION DIAGNOSIS

FOR FRONTAL COLLISION

To repair the SRS for a frontal collision, perform the following steps.

When SRS (except the side air bag) is activated in a collision:

- ① Replace the diagnosis sensor unit.
- ② Remove the air bag modules (except the side air bag module).
- ③ Check the SRS components using the table shown below:
 - Replace any SRS components showing visible signs of damage (dents, cracks, deformation).
- ④ Install new air bag modules (except the side air bag module).
- ⑤ Conduct self-diagnosis using CONSULT-II, "AIR BAG" and "SEAT BELT" warning lamps. Refer to "Self-diagnosis" for details (RS-40). Ensure entire SRS operates properly.

When SRS is not activated in a collision:

- ① Check the SRS components using the table shown below:
 - Replace any SRS components showing visible signs of damage (dents, cracks, deformation).
- ② Conduct self-diagnosis using CONSULT-II, "AIR BAG" and "SEAT BELT" warning lamps. Refer to "Self-diagnosis" for details (RS-40). Ensure entire SRS operates properly.

SRS inspection

Part	SRS (except the side air bag) is activated	SRS is NOT activated
Air bag module (driver and passenger side)	REPLACE Install air bag module with new bolts.	1. Remove air bag module. Check harness cover and connectors for damage, terminals for deformities, and harness for binding. 2-1. Install driver air bag module into the steering wheel to check fit and alignment with the wheel. 2-2. Install passenger air bag module into the instrument panel to check fit with the instrument panel. 3. No damage found, reinstall with new bolts. 4. If damaged—REPLACE. Air bag must be deployed before discarding.
Seat belt pre-tensioner assembly	REPLACE Install seat belt pre-tensioner with new bolts.	1. Remove seat belt pre-tensioners. Check harness cover and connectors for damage, terminals for deformities, and harness for binding. 2. Check belts for damage and anchors for loose mounting. 3. Check retractor for smooth operation. 4. If no damage is found, reinstall with new bolts. 5. If damaged—REPLACE. Seat belt pre-tensioners must be deployed before discarding.
Diagnosis sensor unit	REPLACE Install diagnosis sensor unit with new bolts.	1. Check case and bracket for dents, cracks or deformities. 2. Check connectors for damage, and terminals for deformities. 3. If no damage is found, reinstall with new bolts. 4. If damaged—REPLACE. Install diagnosis sensor unit with new bolts.
Steering wheel	1. Visually check steering wheel for deformities. 2. Check harness (built into steering wheel) and connectors for damage, and terminals for deformities. 3. Install air bag module to check fit or alignment with steering wheel. 4. Check steering wheel for excessive free play. 5. If no damage is found, reinstall. 6. If damaged—REPLACE.	
Spiral cable	1. Visually check spiral cable and combination switch for damage. 2. Check connectors, flat cable and protective tape for damage. 3. Check steering wheel for noise, binding or heavy operation. 4. If no damage is found, reinstall it. 5. If damaged—REPLACE.	
Harness and Connectors	1. Check connectors for poor connection, damage, and terminals for deformities. 2. Check harness for binding, chafing, cuts, or deformities. 3. If no damage is found, reinstall harness and connectors. 4. Damaged—REPLACE damaged section of harness. Do not attempt to repair, splice or modify any SRS harness.	
Instrument panel	Refer to the table on the next page.	

COLLISION DIAGNOSIS

Part	SRS (except the side air bag) is activated	SRS is NOT activated
Instrument panel	<p>1. When passenger air bag inflates, check the following points for bending, deformities or cracks.</p> <ul style="list-style-type: none"> ● Opening portion for passenger air bag ex. (Details differ among models.) 	<p>GI</p> <p>MA</p> <p>EM</p> <p>LC</p> <p>EC</p> <p>ARS193</p> <p>FE</p> <p>CL</p> <p>MT</p> <p>AT</p> <p>FA</p> <p>ARS194</p> <p>RA</p> <p>BR</p> <p>ST</p> <p style="background-color: black; color: white; text-align: center; padding: 2px;">RS</p> <p>BT</p> <p>HA</p> <p>ARS195</p> <p>EL</p>
	<p>2. If no damage is found, reinstall the instrument panel.</p> <p>3. If damaged—REPLACE the instrument panel with bolts.</p>	<p>IDX</p>

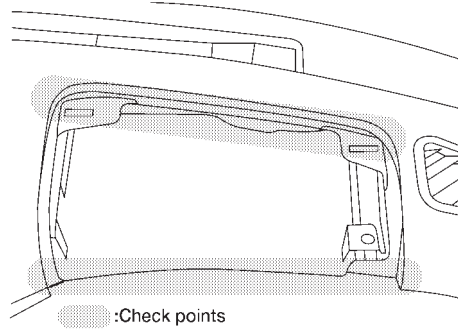

- Passenger air bag module brackets ex. (Details differ among models.)

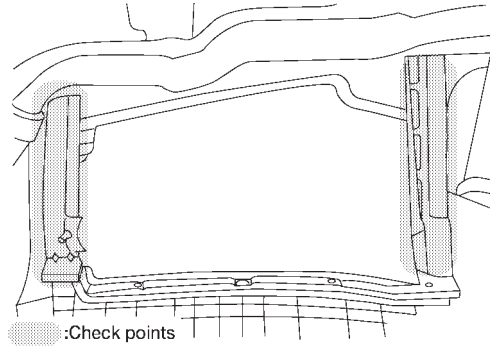

- The portions securing the instrument panel ex. (Details differ among models.)

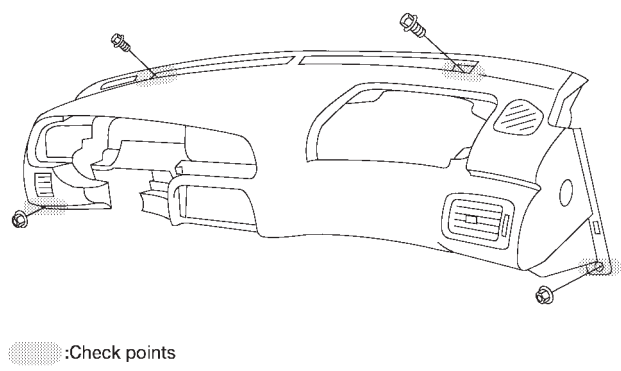

COLLISION DIAGNOSIS

FOR SIDE COLLISION

To repair the SRS for a side collision, perform the following steps.

When the side air bag is activated in the side collision:

- 1) Replace the following component:
 - Diagnosis sensor unit
 - Satellite sensor (on the side on which side air bag is activated)
- 2) Remove the deployed side air bag module.
- 3) Check the SRS components and the related parts using the table shown below.
 - Replace any SRS components and the related parts showing visible signs of damage (dents, cracks, deformation).
- 4) Install new side air bag module (on the side on which side air bag has been activated) with new nuts.
- 5) Conduct self-diagnosis using CONSULT-II, and “AIR BAG” and “SEAT BELT” warning lamp. Refer to “Self-diagnosis” for details (RS-40). Ensure entire SRS operates properly.

When SRS is not activated in the side collision:

- 1) Check the SRS components and the related parts using the table shown below.
 - Replace any SRS components and the related parts showing visible signs of damage (dents, cracks, deformation).
- 2) Conduct self-diagnosis using CONSULT-II, and “AIR BAG” and “SEAT BELT” warning lamp. Refer to “Self-diagnosis” for details (RS-40). Ensure entire SRS operates properly.

SRS Inspection (For side collision)

Part	Side air bag is activated	SRS is NOT activated
Built-in type side air bags module (LH or RH)	REPLACE all parts of seat back with deployed side air bag module.	<ol style="list-style-type: none"> 1. Check for visible signs of damage (dents, tears, deformation) of the seat back on the collision side. 2. If damaged—REPLACE the damaged seat parts with new bolts and remove the side air bag module. 3. Check for visible signs of damaged (tears etc.) of the side air bag module. 4. Check harness and connectors for damage, and terminals for deformities. 5. If no damaged is found, reinstall the side air bag module with new torx nuts coated with bonding agent. 6. If damaged—REPLACE the side air bag module with new torx nuts coated with bonding agent. Air bag must be deployed before disposing of it.
Satellite sensor (LH or RH)	REPLACE the satellite sensor on the collision side with new nuts coated with bonding agent. (Repair the center pillar inner, etc. before installing new one if damaged.)	<ol style="list-style-type: none"> 1. Remove the satellite sensor on the collision side. Check harness connectors for damage, terminals for deformities, and harness for binding. 2. Check for visible signs of damage (dents, cracks, deformation) of the satellite sensor. 3. Install the satellite sensor to check fit. 4. If no damage is found, reinstall the satellite sensor with new nuts coated with bonding agent. 5. If damaged—REPLACE the satellite sensor with new nuts coated with bonding agent.
Diagnosis sensor unit	REPLACE the diagnosis sensor unit with the new bolts.	<ol style="list-style-type: none"> 1. Check case and bracket for dents, cracks or deformities. 2. Check connectors for damage, and terminals for deformities. 3. If no damage is found, reinstall the diagnosis sensor unit with new special bolts and ground bolt. 4. If damaged—REPLACE. Install the diagnosis sensor unit with new special bolts and ground bolt.

COLLISION DIAGNOSIS

Part	Side air bag is activated	SRS is NOT activated	
Seat belt pre-tensioner assembly	<ol style="list-style-type: none"> 1. Check if the seat belt can be extended smoothly. If the seat belt cannot be extended smoothly. <ul style="list-style-type: none"> – Check for deformities of the center pillar inner. – If the center pillar inner has no damage, REPLACE the seat belt pre-tensioner assembly. 2. Remove the seat belt pre-tensioner assembly on the collision side. Check harness cover and connectors for damage, terminals for deformities, and harness for binding. 3. Check for visible signs of damage (dents, cracks, deformation) of the seat belt pre-tensioner assembly. 4. If no damage is found, reinstall the seat belt pre-tensioner assembly with new bolts coated with bonding agent. 5. If damaged—REPLACE the seat belt pre-tensioner assembly with new bolts coated with bonding agent. The seat belt pre-tensioner assembly must be deployed before disposing of it. 		GI MA EM LC
Seat	REPLACE all parts of seat back (including seat back frame)	<ol style="list-style-type: none"> 1. Visually check the seat on the collision side. 2. Remove the seat on the collision side and check the following for damage and deformities. <ul style="list-style-type: none"> ● Harness, connectors and terminals ● Frame and recliner (for front and rear seat), and also adjuster and slides (for front seat) 3. If no damage is found, reinstall the seat. 4. If damaged—REPLACE the damaged seat parts with new bolts. 	EC FE CL
Center pillar inner	<ol style="list-style-type: none"> 1. Check the center pillar inner on the collision side for damage (dents, cracks, deformation). 2. If damaged—REPAIR the center pillar inner. 		MT
Trim	<ol style="list-style-type: none"> 1. Check for visible signs of damage (dents, cracks, deformation) of the interior trim on the collision side. If damaged—REPLACE the damaged trim parts. 		AT

GI

MA

EM

LC

EC

FE

CL

MT

AT

FA

RA

BR

ST

RS

BT

HA

EL

IDX

NOTES