

A
B
AT
D
E
F
G
H
I
J
K
L
M

SECTION **AT**

AUTOMATIC TRANSAXLE

CONTENTS

TROUBLE DIAGNOSIS - INDEX	5	TROUBLE DIAGNOSIS - GENERAL DESCRIPTION	82
Alphabetical & P No. Index for DTC	5	Symptom Chart	82
PRECAUTIONS	7	TCM Terminals and Reference Value	92
Precautions for Supplemental Restraint System (SRS) "AIR BAG" and "SEAT BELT PRE-TENSIONER"	7	CAN Communication	95
Precautions for On Board Diagnostic (OBD) System of A/T and Engine	7	TROUBLE DIAGNOSIS FOR POWER SUPPLY ...	100
Precautions	7	Wiring Diagram — AT — MAIN	100
Service Notice or Precautions	9	Diagnostic Procedure	101
Wiring Diagrams and Trouble Diagnosis	10	DTC P0705 PARK/NEUTRAL POSITION SWITCH	103
PREPARATION	11	Description	103
Special Service Tools	11	On Board Diagnosis Logic	103
Commercial Service Tools	14	Possible Cause	103
OVERALL SYSTEM	15	Diagnostic Trouble Code (DTC) Confirmation Procedure	103
A/T Electrical Parts Location	15	Wiring Diagram — AT — PNP/SW	105
Circuit Diagram	16	Diagnostic Procedure	106
Cross-sectional View	17	DTC P0710 A/T FLUID TEMPERATURE SENSOR CIRCUIT	109
Hydraulic Control Circuit	18	Description	109
Shift Mechanism	19	On Board Diagnosis Logic	109
Control System	28	Possible Cause	109
Control Mechanism	30	Diagnostic Trouble Code (DTC) Confirmation Procedure	109
Control Valve	34	Wiring Diagram — AT — FTS	111
ON BOARD DIAGNOSTIC SYSTEM DESCRIPTION	36	Diagnostic Procedure	113
Introduction	36	DTC P0720 VEHICLE SPEED SENSOR-A/T (REVOLUTION SENSOR)	115
OBD-II Function for A/T System	36	Description	115
One or Two Trip Detection Logic of OBD-II	36	On Board Diagnosis Logic	115
OBD-II Diagnostic Trouble Code (DTC)	36	Possible Cause	115
Malfunction Indicator Lamp (MIL)	40	Diagnostic Trouble Code (DTC) Confirmation Procedure	115
CONSULT-II	40	Wiring Diagram — AT — VSSA/T	117
Diagnostic Procedure Without CONSULT-II	50	Diagnostic Procedure	118
TROUBLE DIAGNOSIS - INTRODUCTION	55	DTC P0725 ENGINE SPEED SIGNAL	120
Introduction	55	Description	120
Work Flow	59	On Board Diagnosis Logic	120
TROUBLE DIAGNOSIS - BASIC INSPECTION	61	Possible Cause	120
A/T Fluid Check	61	Diagnostic Trouble Code (DTC) Confirmation Procedure	120
Stall Test	61		
Line Pressure Test	65		
Road Test	66		

Wiring Diagram — AT — ENGSS	121	DTC P0750 SHIFT SOLENOID VALVE A	165
Diagnostic Procedure	122	Description	165
DTC P0731 A/T 1ST GEAR FUNCTION	124	On Board Diagnosis Logic	165
Description	124	Possible Cause	165
On Board Diagnosis Logic	124	Diagnostic Trouble Code (DTC) Confirmation Procedure	165
Possible Cause	124	Wiring Diagram — AT — SSV/A	167
Diagnostic Trouble Code (DTC) Confirmation Procedure	124	Diagnostic Procedure	168
Wiring Diagram — AT — 1ST	126	DTC P0755 SHIFT SOLENOID VALVE B	170
Diagnostic Procedure	127	Description	170
DTC P0732 A/T 2ND GEAR FUNCTION	129	On Board Diagnosis Logic	170
Description	129	Possible Cause	170
On Board Diagnosis Logic	129	Diagnostic Trouble Code (DTC) Confirmation Procedure	170
Possible Cause	129	Wiring Diagram — AT — SSV/B	172
Diagnostic Trouble Code (DTC) Confirmation Procedure	129	Diagnostic Procedure	173
Wiring Diagram — AT — 2ND	131	DTC P1705 THROTTLE POSITION SENSOR [ACCELERATOR PEDAL POSITION (APP) SENSOR]	175
Diagnostic Procedure	132	Description	175
DTC P0733 A/T 3RD GEAR FUNCTION	134	On Board Diagnosis Logic	176
Description	134	Possible Cause	176
On Board Diagnosis Logic	134	Diagnostic Trouble Code (DTC) Confirmation Procedure	176
Possible Cause	134	Wiring Diagram — AT — TPS	178
Diagnostic Trouble Code (DTC) Confirmation Procedure	134	Diagnostic Procedure	179
Wiring Diagram — AT — 3RD	136	DTC P1760 OVERRUN CLUTCH SOLENOID VALVE	181
Diagnostic Procedure	137	Description	181
DTC P0734 A/T 4TH GEAR FUNCTION	139	On Board Diagnosis Logic	181
Description	139	Possible Cause	181
On Board Diagnosis Logic	139	Diagnostic Trouble Code (DTC) Confirmation Procedure	181
Possible Cause	139	Wiring Diagram — AT — OVRCSV	183
Diagnostic Trouble Code (DTC) Confirmation Procedure	139	Diagnostic Procedure	184
Wiring Diagram — AT — 4TH	141	DTC U1000 CAN COMMUNICATION LINE	186
Diagnostic Procedure	142	Description	186
DTC P0740 TORQUE CONVERTER CLUTCH SOLENOID VALVE	146	On Board Diagnosis Logic	186
Description	146	Possible Cause	186
On Board Diagnosis Logic	146	DTC Confirmation Procedure	186
Possible Cause	146	Wiring Diagram — AT — CAN	187
Diagnostic Trouble Code (DTC) Confirmation Procedure	146	Diagnostic Procedure	188
Wiring Diagram — AT — TCV	148	DTC BATT/FLUID TEMP SEN (A/T FLUID TEMP SENSOR CIRCUIT AND TCM POWER SOURCE)	189
Diagnostic Procedure	149	Description	189
DTC P0744 A/T TCC S/V FUNCTION (LOCK-UP)	151	On Board Diagnosis Logic	189
Description	151	Possible Cause	189
On Board Diagnosis Logic	151	Diagnostic Trouble Code (DTC) Confirmation Procedure	189
Possible Cause	151	Wiring Diagram — AT — BA/FTS	191
Diagnostic Trouble Code (DTC) Confirmation Procedure	151	Diagnostic Procedure	192
Wiring Diagram — AT — TCCSIG	153	DTC VEHICLE SPEED SENSOR MTR	196
Diagnostic Procedure	154	Description	196
DTC P0745 LINE PRESSURE SOLENOID VALVE	159	On Board Diagnosis Logic	196
Description	159	Possible Cause	196
On Board Diagnosis Logic	159	Diagnostic Trouble Code (DTC) Confirmation Procedure	196
Possible Cause	159	Wiring Diagram — AT — VSSMTR	198
Diagnostic Trouble Code (DTC) Confirmation Procedure	159	Diagnostic Procedure	199
Wiring Diagram — AT — LPSV	161		
Diagnostic Procedure	162		

DTC TURBINE REVOLUTION SENSOR	200	ON-VEHICLE SERVICE	264	
Description	200	Control Valve Assembly and Accumulators	264	A
Wiring Diagram — AT — TRSA/T	202	Revolution Sensor Replacement	266	
Diagnostic Procedure	203	Turbine Revolution Sensor Replacement	266	B
Component Inspection	204	Park/Neutral Position (PNP) Switch Adjustment	266	
DTC CONTROL UNIT (RAM), CONTROL UNIT (ROM)	205	Control Cable Adjustment	267	
Description	205	Differential Side Oil Seal Replacement	267	
On Board Diagnosis Logic	205	REMOVAL AND INSTALLATION	269	AT
Possible Cause	205	Removal	269	
Diagnostic Trouble Code (DTC) Confirmation Procedure	205	Installation	270	
Diagnostic Procedure	206	OVERHAUL	272	D
DTC CONTROL UNIT (EEP ROM)	207	Components	272	
Description	207	Oil Channel	275	E
Diagnostic Procedure	208	Locations of Adjusting Shims, Needle Bearings, Thrust Washers and Snap Rings	276	
TROUBLE DIAGNOSIS FOR SYMPTOMS	209	DISASSEMBLY	277	
Wiring Diagram — AT — NONDTC	209	Disassembly	277	F
1. A/T Check (Position) Indicator Lamp Does Not Come On	213	REPAIR FOR COMPONENT PARTS	292	
2. Engine Cannot Be Started In P and N Position	215	Manual Shaft	292	G
3. In P Position, Vehicle Moves Forward or Backward When Pushed	216	Oil Pump	295	
4. In N Position, Vehicle Moves	217	Control Valve Assembly	299	
5. Large Shock. N → R Position	219	Control Valve Upper Body	307	H
6. Vehicle Does Not Creep Backward In R Position	221	Control Valve Lower Body	311	
7. Vehicle Does Not Creep Forward in D, 3, 2 or 1 Position	224	Reverse Clutch	314	
8. Vehicle Cannot Be Started From D1	227	High Clutch	317	I
9. A/T Does Not Shift: D1 → D2 or Does Not Kick-down: D4 → D2	230	Forward and Overrun Clutches	322	
10. A/T Does Not Shift: D2 → D3	233	Low & Reverse Brake	328	J
11. A/T Does Not Shift: D3 → D4	236	Rear Internal Gear, Forward Clutch Hub and Overrun Clutch Hub	331	
12. A/T Does Not Perform Lock-up	239	Output Shaft, Idler Gear, Reduction Pinion Gear and Bearing Retainer	335	
13. A/T Does Not Hold Lock-up Condition	241	Band Servo Piston Assembly	340	K
14. Lock-up Is Not Released	243	Final Drive	345	
15. Engine Speed Does Not Return To Idle (Light Braking D4 → D3)	244	ASSEMBLY	350	L
16. Vehicle Does Not Start From D1	246	Assembly (1)	350	
17. A/T Does Not Shift: D4 → 33, When A/T Selector Lever D → 3	247	Adjustment (1)	351	
18. A/T Does Not Shift: 33 → 22, When Selector Lever 3 → 2 Position	248	Assembly (2)	356	
19. A/T Does Not Shift: 22 → 11, When Selector Lever 2 → 1 Position	249	Adjustment (2)	363	
20. Vehicle Does Not Decelerate By Engine Brake	250	Assembly (3)	366	M
21. TCM Self-diagnosis Does Not Activate (PNP & 3 Position Switches Circuit Checks), and Throttle Position Sensor [Accelerator Pedal Position (APP) Sensor] Circuit Check	250	SERVICE DATA AND SPECIFICATIONS (SDS) ...	373	
A/T SHIFT LOCK SYSTEM	256	General Specifications	373	
Description	256	Shift Schedule	373	
Shift Lock System Electrical Parts Location	256	Stall Revolution	374	
Wiring Diagram — SHIFT —	257	Line Pressure	374	
Shift Lock Control Unit Reference Values	259	Control Valves	374	
Component Inspection	259	Accumulator	375	
SHIFT CONTROL SYSTEM	262	Clutch and Brakes	376	
Control Device	262	Final Drive	378	
Control Cable	263	Planetary Carrier and Oil Pump	379	
		Input Shaft	379	
		Reduction Pinion Gear	380	
		Band Servo	380	
		Output Shaft	381	
		Bearing Retainer	381	
		Total End Play	381	
		Reverse Clutch End Play	381	
		Removal and Installation	382	
		Shift Solenoid Valves	382	
		Solenoid Valves	382	

A/T Fluid Temperature Sensor	382	Dropping Resistor	382
Revolution Sensor	382	Turbine Revolution Sensor	383

TROUBLE DIAGNOSIS - INDEX

TROUBLE DIAGNOSIS - INDEX

PFP:00000

Alphabetical & P No. Index for DTC ALPHABETICAL INDEX FOR DTC

ECS0069X

Items (CONSULT-II screen terms)	DTC	Reference page
	CONSULT-II GST*1	
A/T 1ST GR FNCTN	P0731	AT-124
A/T 2ND GR FNCTN	P0732	AT-129
A/T 3RD GR FNCTN	P0733	AT-134
A/T 4TH GR FNCTN	P0734	AT-139
A/T TCC S/V FNCTN	P0744	AT-151
ATF TEMP SEN/CIRC	P0710	AT-109
ENGINE SPEED SIG	P0725	AT-120
L/PRESS SOL/CIRC	P0745	AT-159
O/R CLTCH SOL/CIRC	P1760	AT-181
PNP SW/CIRC	P0705	AT-103
SFT SOL A/CIRC*2	P0750	AT-165
SFT SOL B/CIRC*2	P0755	AT-170
TCC SOLENOID/CIRC	P0740	AT-146
TP SEN/CIRC A/T*2	P1705	AT-175
VEH SPD SEN/CIR AT*3	P0720	AT-115
CAN COMM CIRCUIT	U1000	AT-186

*1: These numbers are prescribed by SAE J2012.

*2: When the fail-safe operation occurs, the MIL illuminates.

*3: The MIL illuminates when both the "Revolution sensor signal" and the "Vehicle speed sensor signal" meet the fail-safe condition at the same time.

TROUBLE DIAGNOSIS - INDEX

P NO. INDEX FOR DTC

DTC	Items (CONSULT-II screen terms)	Reference page
CONSULT-II GST*1		
P0705	PNP SW/CIRC	AT-103
P0710	ATF TEMP SEN/CIRC	AT-109
P0720	VEH SPD SEN/CIR AT*3	AT-115
P0725	ENGINE SPEED SIG	AT-120
P0731	A/T 1ST GR FNCTN	AT-124
P0732	A/T 2ND GR FNCTN	AT-129
P0733	A/T 3RD GR FNCTN	AT-134
P0734	A/T 4TH GR FNCTN	AT-139
P0740	TCC SOLENOID/CIRC	AT-146
P0744	A/T TCC S/V FNCTN	AT-151
P0745	L/PRESS SOL/CIRC	AT-159
P0750	SFT SOL A/CIRC*2	AT-165
P0755	SFT SOL B/CIRC*2	AT-170
P1705	TP SEN/CIRC A/T*2	AT-175
P1760	O/R CLTCH SOL/CIRC	AT-181
U1000	CAN COMM CIRCUIT	AT-186

*1: These numbers are prescribed by SAE J2012.

*2: When the fail-safe operation occurs, the MIL illuminates.

*3: The MIL illuminates when both the "Revolution sensor signal" and the "Vehicle speed sensor signal" meet the fail-safe condition at the same time.

PRECAUTIONS

PRECAUTIONS

PFP:00001

Precautions for Supplemental Restraint System (SRS) “AIR BAG” and “SEAT BELT PRE-TENSIONER”

ECS006HC

The Supplemental Restraint System such as “AIR BAG” and “SEAT BELT PRE-TENSIONER”, used along with a front seat belt, helps to reduce the risk or severity of injury to the driver and front passenger for certain types of collision. This system includes seat belt switch inputs and dual stage front air bag modules. The SRS system uses the seat belt switches to determine the front air bag deployment, and may only deploy one front air bag, depending on the severity of a collision and whether the front occupants are belted or unbelted. Information necessary to service the system safely is included in the SRS and SB section of this Service Manual.

WARNING:

- To avoid rendering the SRS inoperative, which could increase the risk of personal injury or death in the event of a collision which would result in air bag inflation, all maintenance must be performed by an authorized NISSAN/INFINITI dealer.
- Improper maintenance, including incorrect removal and installation of the SRS, can lead to personal injury caused by unintentional activation of the system. For removal of Spiral Cable and Air Bag Module, see the SRS section.
- Do not use electrical test equipment on any circuit related to the SRS unless instructed to in this Service Manual. SRS wiring harnesses can be identified by yellow and/or orange harness connectors.

Precautions for On Board Diagnostic (OBD) System of A/T and Engine

ECS0069Z

The ECM has an on board diagnostic system. It will light up the malfunction indicator lamp (MIL) to warn the driver of a malfunction causing emission deterioration.

CAUTION:

- Be sure to turn the ignition switch OFF and disconnect the negative battery terminal before any repair or inspection work. The open/short circuit of related switches, sensors, solenoid valves, etc. will cause the MIL to light up.
- Be sure to connect and lock the connectors securely after work. A loose (unlocked) connector will cause the MIL to light up due to an open circuit. (Be sure the connector is free from water, grease, dirt, bent terminals, etc.)
- Be sure to route and secure the harnesses properly after work. Interference of the harness with a bracket, etc. may cause the MIL to light up due to a short circuit.
- Be sure to connect rubber tubes properly after work. A misconnected or disconnected rubber tube may cause the MIL to light up due to a malfunction of the EGR system or fuel injection system, etc.
- Be sure to erase the unnecessary malfunction information (repairs completed) from the TCM or ECM before returning the vehicle to the customer.

Precautions

ECS006A0

- Before connecting or disconnecting the TCM harness connector, turn ignition switch OFF and disconnect negative battery terminal. Failure to do so may damage the TCM. Because battery voltage is applied to TCM even if ignition switch is turned off.

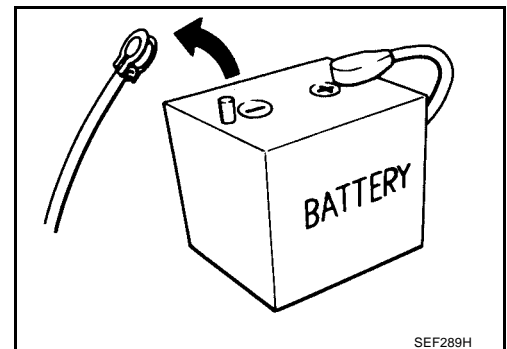

PRECAUTIONS

- When connecting or disconnecting pin connectors into or from TCM, take care not to damage pin terminals (bend or break).
Make sure that there are not any bends or breaks on TCM pin terminal, when connecting pin connectors.

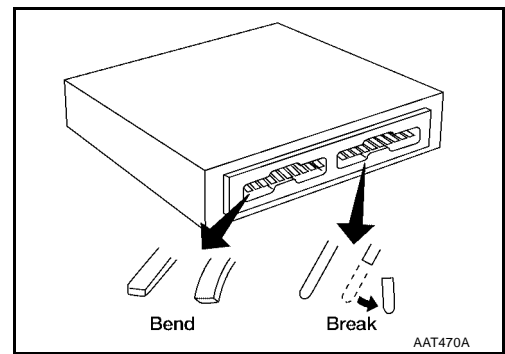

- Before replacing TCM, perform TCM input/output signal inspection and make sure whether TCM functions properly or not. Refer to [AT-29, "INPUT/OUTPUT SIGNAL OF TCM"](#).

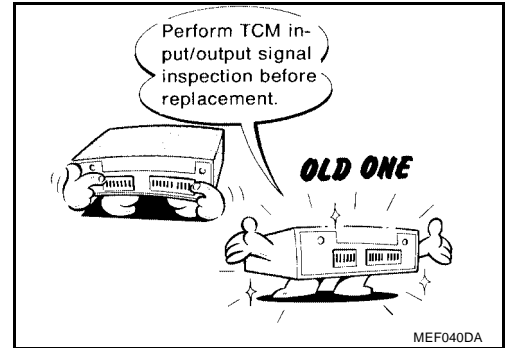

- After performing each TROUBLE DIAGNOSIS, perform "DTC (Diagnostic Trouble Code) CONFIRMATION PROCEDURE".
The DTC should not be displayed in the "DTC CONFIRMATION PROCEDURE" if the repair is completed.

- Before proceeding with disassembly, thoroughly clean the outside of the transaxle. It is important to prevent the internal parts from becoming contaminated by dirt or other foreign matter.
- Disassembly should be done in a clean work area.
- Use lint-free cloth or towels for wiping parts clean. Common shop rags can leave fibers that could interfere with the operation of the transaxle.
- Place disassembled parts in order for easier and proper assembly.
- All parts should be carefully cleaned with a general purpose, non-flammable solvent before inspection or reassembly.
- Gaskets, seals and O-rings should be replaced any time the transaxle is disassembled.
- It is very important to perform functional tests whenever they are indicated.
- The valve body contains precision parts and requires extreme care when parts are removed and serviced. Place disassembled valve body parts in order for easier and proper assembly. Care will also prevent springs and small parts from becoming scattered or lost.
- Properly installed valves, sleeves, plugs, etc. will slide along bores in valve body under their own weight.
- Before assembly, apply a coat of recommended ATF to all parts. Apply petroleum jelly to protect O-rings and seals, or hold bearings and washers in place during assembly. Do not use grease.
- Extreme care should be taken to avoid damage to O-rings, seals and gaskets when assembling.
- Replace ATF cooler if excessive foreign material is found in oil pan or clogging strainer. Refer to [AT-9, "ATF COOLER SERVICE"](#).
- After overhaul, refill the transaxle with new ATF.
- When the A/T drain plug is removed, only some of the fluid is drained. Old A/T fluid will remain in torque converter and ATF cooling system.
Always follow the procedures when changing A/T fluid. Refer to [MA-30, "Changing A/T Fluid"](#).

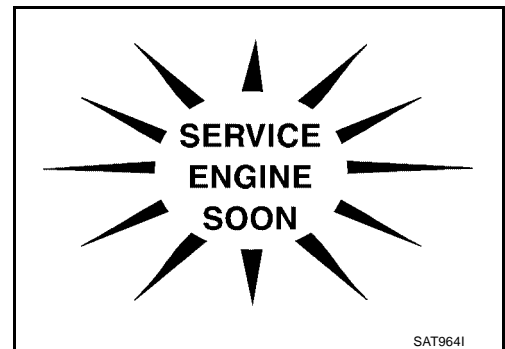

PRECAUTIONS

ECS006A1

Service Notice or Precautions

FAIL-SAFE

The TCM has an electronic Fail-Safe (limp home mode). This allows the vehicle to be driven even if a major electrical input/output device circuit is damaged.

Under Fail-Safe, the vehicle always runs in third gear, even with a shift lever position of 1, 2 or D. The customer may complain of sluggish or poor acceleration.

When the ignition key is turned ON following Fail-Safe operation, A/T check (position) indicator lamp blinks for about 8 seconds. [For "TCM Self-diagnostic Procedure (No Tools)", refer to [AT-51, "TCM SELF-DIAGNOSTIC PROCEDURE \(NO TOOLS\)"](#) .]

The blinking of the A/T check (position) indicator lamp for about 8 seconds will appear only once and be cleared. The customer may resume normal driving conditions.

Always follow the "Work Flow" (Refer to [AT-59, "Work Flow"](#)).

The SELF-DIAGNOSIS results will be as follows:

- The first SELF-DIAGNOSIS will indicate damage to the vehicle speed sensor or the revolution sensor.
- During the next SELF-DIAGNOSIS, performed after checking the sensor, no damages will be indicated.

TORQUE CONVERTER SERVICE

The torque converter should be replaced under any of the following conditions:

- External leaks in the hub weld area.
- Converter hub is scored or damaged.
- Converter pilot is broken, damaged or fits poorly into crankshaft.
- Steel particles are found after flushing the cooler and cooler lines.
- Pump is damaged or steel particles are found in the converter.
- Vehicle has TCC shudder and/or no TCC apply. Replace only after all hydraulic and electrical diagnoses have been made. (Converter clutch material may be glazed.)
- Converter is contaminated with engine coolant containing antifreeze.
- Internal failure of stator roller clutch.
- Heavy clutch debris due to overheating (blue converter).
- Steel particles or clutch lining material found in fluid filter or on magnet when no internal parts in unit are worn or damaged — indicates that lining material came from converter.

The torque converter should not be replaced if:

- The fluid has an odor, is discolored, and there is no evidence of metal or clutch facing particles.
- The threads in one or more of the converter bolt holes are damaged.
- Transaxle failure did not display evidence of damaged or worn internal parts, steel particles or clutch plate lining material in unit and inside the fluid filter.
- Vehicle has been exposed to high mileage (only). The exception may be where the torque converter clutch dampener plate lining has seen excess wear by vehicles operated in heavy and/or constant traffic, such as taxi, delivery or police use.

ATF COOLER SERVICE

If A/T fluid contains frictional material (clutches, bands, etc.), replace radiator and flush cooler line using cleaning solvent and compressed air after repair of A/T. Refer to [CO-10, "RADIATOR"](#) (with QR25DE), or [CO-31, "RADIATOR"](#) (with VQ35DE).

OBD-II SELF-DIAGNOSIS

- A/T self-diagnosis is performed by the TCM in combination with the ECM. The results can be read through the blinking pattern of the A/T check (position) indicator or the malfunction indicator lamp (MIL). Refer to the table on [AT-41](#) for the indicator used to display each self-diagnostic result.

- The self-diagnostic results indicated by the MIL are automatically stored in both the ECM and TCM memories.

Always perform the procedure "HOW TO ERASE DTC" on [AT-38](#) to complete the repair and avoid unnecessary blinking of the MIL.

- The following self-diagnostic items can be detected using ECM self-diagnostic results mode* only when the A/T check (position) indicator lamp does not indicate any malfunctions.
 - park/neutral position (PNP) switch
 - A/T 1st, 2nd, 3rd, or 4th gear function

PRECAUTIONS

- A/T TCC S/V function (lock-up).
*: For details of OBD-II, refer to [EC-53, "ON BOARD DIAGNOSTIC \(OBD\) SYSTEM"](#) (with QR25DE), or [EC-677, "ON BOARD DIAGNOSTIC \(OBD\) SYSTEM"](#) (with VQ35DE).
- **Certain systems and components, especially those related to OBD, may use a new style slide-locking type harness connector.**
For description and how to disconnect, refer to [GI-22, "How to Check Terminal"](#) .

Wiring Diagrams and Trouble Diagnosis

ECS006A2

When you read wiring diagrams, refer to the following:

- [GI-12, "How to Read Wiring Diagrams"](#)
- [PG-3, "POWER SUPPLY ROUTING CIRCUIT"](#)

When you perform trouble diagnosis, refer to the following:

- [GI-10, "HOW TO FOLLOW TEST GROUPS IN TROUBLE DIAGNOSES"](#)
- [GI-25, "How to Perform Efficient Diagnosis for an Electrical Incident"](#)

PREPARATION

PREPARATION

PFP:00002

Special Service Tools

ECS006A3

The actual shapes of Kent-Moore tools may differ from those of special service tools illustrated here.

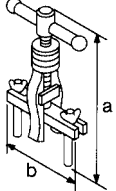
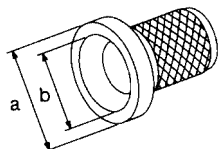
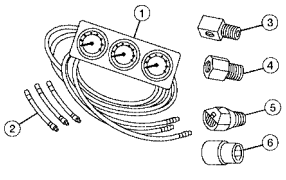
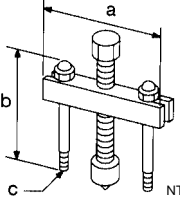
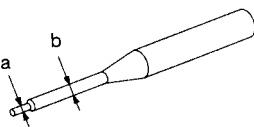
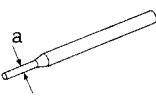
Tool number (Kent-Moore No.) Tool name	Description
KV381054S0 (J34286) Puller <div style="text-align: center;">  <p>NT414</p> </div>	<ul style="list-style-type: none"> ● Removing differential side oil seals ● Removing differential side bearing outer race ● Removing idler gear bearing outer race <p>a: 250 mm (9.84 in) b: 160 mm (6.30 in)</p>
ST33400001 (J26082) Drift <div style="text-align: center;">  <p>NT086</p> </div>	<ul style="list-style-type: none"> ● Installing differential side oil seal (RH side) ● Installing oil seal on oil pump housing <p>a: 60 mm (2.36 in) dia. b: 47 mm (1.85 in) dia.</p>
(J34301-C) Oil pressure gauge set 1 (J34301-1) Oil pressure gauge 2 (J34301-2) Hoses 3 (J34298) Adapter 4 (J34282-2) Adapter 5 (790-301-1230-A) 60° Adapter 6 (J34301-15) Square socket <div style="text-align: center;">  <p>AAT896</p> </div>	<ul style="list-style-type: none"> ● Measuring line pressure
ST27180001 (J25726-A) Puller <div style="text-align: center;">  <p>NT424</p> </div>	<ul style="list-style-type: none"> ● Removing idler gear <p>a: 100 mm (3.94 in) b: 110 mm (4.33 in) c: M8 x 1.25P</p>
ST23540000 (J25689-A) Pin punch <div style="text-align: center;">  <p>NT442</p> </div>	<ul style="list-style-type: none"> ● Removing and installing parking rod plate and manual plate pins <p>a: 2.3 mm (0.091 in) dia. b: 4 mm (0.16 in) dia.</p>
ST25710000 (J25689-A) Pin punch <div style="text-align: center;">  <p>NT410</p> </div>	<ul style="list-style-type: none"> ● Aligning groove of manual shaft and hole of transmission case <p>a: 2 mm (0.08 in) dia.</p>

PREPARATION

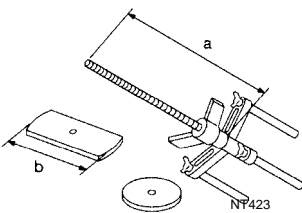
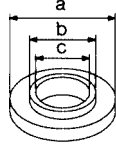
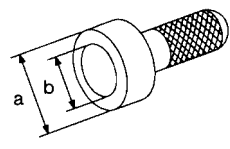
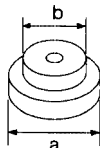
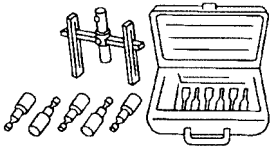
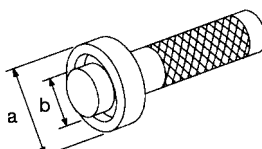
Tool number (Kent-Moore No.) Tool name	Description
KV32101000 (J25689-A) Pin punch  NT410	<ul style="list-style-type: none"> ● Removing and installing manual shaft retaining pin ● Removing and installing pinion mate shaft lock pin <p>a: 4 mm (0.16 in) dia.</p>
KV31102400 (J34285 and J34285-87) Clutch spring compressor  NT423	<ul style="list-style-type: none"> ● Removing and installing clutch return springs ● Installing low and reverse brake piston <p>a: 320 mm (12.60 in) b: 174 mm (6.85 in)</p>
KV40100630 (J26092) Drift  NT107	<ul style="list-style-type: none"> ● Installing reduction gear bearing inner race ● Installing idler gear bearing inner race <p>a: 67.5 mm (2.657 in) dia. b: 44 mm (1.73 in) dia. c: 38.5 mm (1.516 in) dia.</p>
ST30720000 (J25405 and J34331) Bearing installer  NT115	<ul style="list-style-type: none"> ● Installing idler gear bearing outer race <p>a: 77 mm (3.03 in) dia. b: 55.5 mm (2.185 in) dia.</p>
ST35321000 () Drift  NT073	<ul style="list-style-type: none"> ● Installing output shaft bearing <p>a: 49 mm (1.93 in) dia. b: 41 mm (1.61 in) dia.</p>
(J34291-A) Shim setting gauge set  NT101	<ul style="list-style-type: none"> ● Selecting oil pump cover bearing race and oil pump thrust washer ● Selecting side gear thrust washer
ST33230000 (J25805-01) Drift  NT084	<ul style="list-style-type: none"> ● Installing differential side bearing inner race (RH side) <p>a: 51 mm (2.01 in) dia. b: 28.5 mm (1.122 in) dia.</p>

PREPARATION

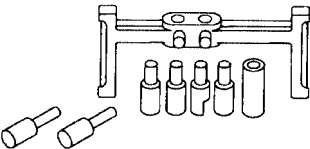
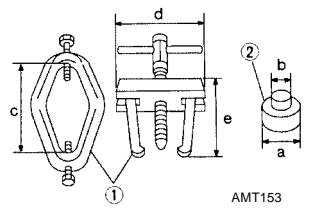
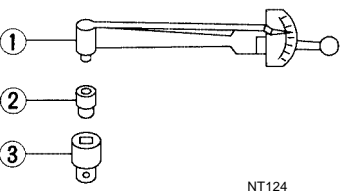
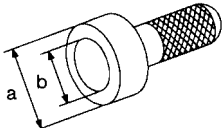
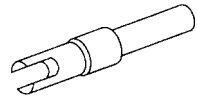
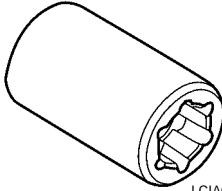
Tool number (Kent-Moore No.) Tool name	Description	
(J34290) Shim selecting tool set  NT080	<ul style="list-style-type: none"> ● Selecting differential side bearing adjusting shim 	A B AT
ST3306S001 (J22888-D) Differential side bearing puller set 1 ST33051001 (J22888-D) Puller 2 ST33061000 (J8107-2) Adapter  AMT153	<ul style="list-style-type: none"> ● Removing differential side bearing inner race <p> a: 38 mm (1.50 in) dia. b: 28.5 mm (1.122 in) dia. c: 130 mm (5.12 in) d: 135 mm (5.31 in) e: 100 mm (3.94 in) </p>	D E F
ST3127S000 (J25765-A) Preload gauge 1 GG91030000 (J25765-A) Torque wrench 2 HT62940000 (—) Socket adapter 3 HT62900000 (—) Socket adapter  NT124	<ul style="list-style-type: none"> ● Checking differential side bearing preload 	G H I
ST35271000 (J26091) Drift  NT115	<ul style="list-style-type: none"> ● Installing idler gear <p> a: 72 mm (2.83 in) dia. b: 63 mm (2.48 in) dia. </p>	J K
(J39713) Preload adapter  NT087	<ul style="list-style-type: none"> ● Selecting differential side bearing adjusting shim ● Checking differential side bearing preload 	L M
(J45816) E20 TORX socket  LCIA0258E	<ul style="list-style-type: none"> ● Removing flex plate bolts on vehicles equipped with QR25DE engines. 	

PREPARATION

Commercial Service Tools

ECS006A4

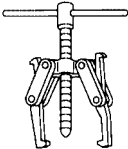
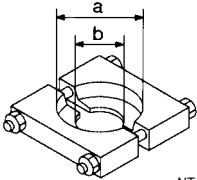
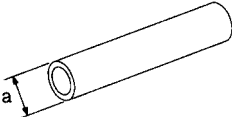
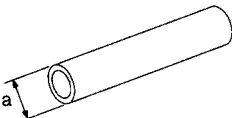
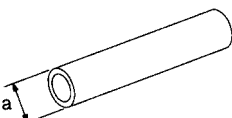
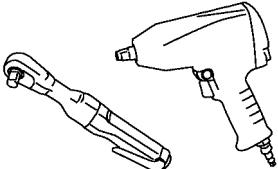
Tool name	Description
Puller  NT077	<ul style="list-style-type: none"> ● Removing idler gear bearing inner race ● Removing and installing band servo piston snap ring
Puller  NT411	<ul style="list-style-type: none"> ● Removing reduction gear bearing inner race <p>a: 60 mm (2.36 in) dia. b: 35 mm (1.38 in) dia.</p>
Drift  NT083	<ul style="list-style-type: none"> ● Installing needle bearing on bearing retainer <p>a: 36 mm (1.42 in) dia.</p>
Drift  NT083	<ul style="list-style-type: none"> ● Removing needle bearing from bearing retainer <p>a: 33.5 mm (1.319 in) dia.</p>
Drift  NT083	<ul style="list-style-type: none"> ● Installing differential side bearing outer race (RH side) <p>a: 75 mm (2.95 in) dia.</p>
Power tool  PBIC0190E	<ul style="list-style-type: none"> ● Removing transaxle assembly ● Removing transaxle oil pan ● Removing transaxle case and cover

OVERALL SYSTEM

OVERALL SYSTEM

A/T Electrical Parts Location

PFP:00000

ECS006A5

A

B

AT

D

E

F

G

H

I

J

K

L

M

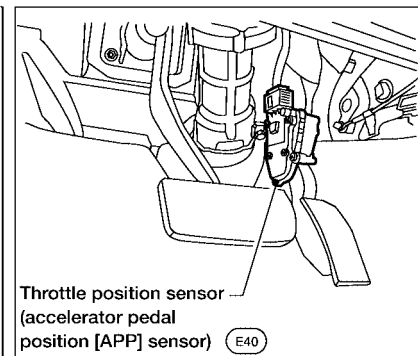
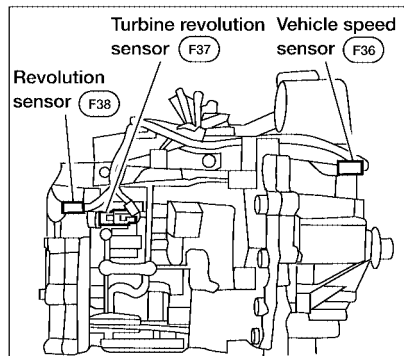
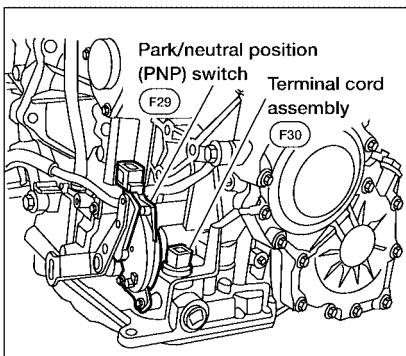
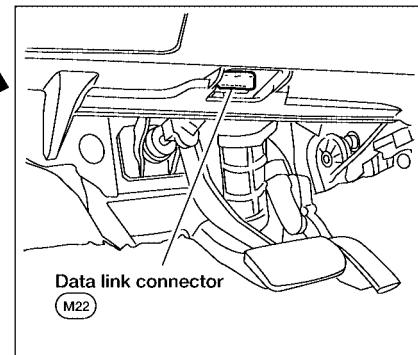
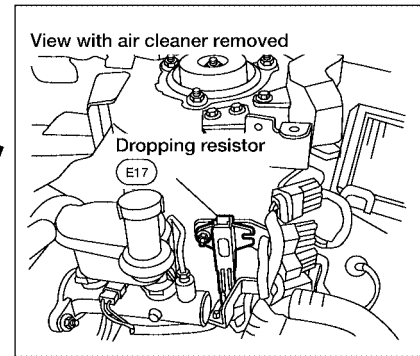
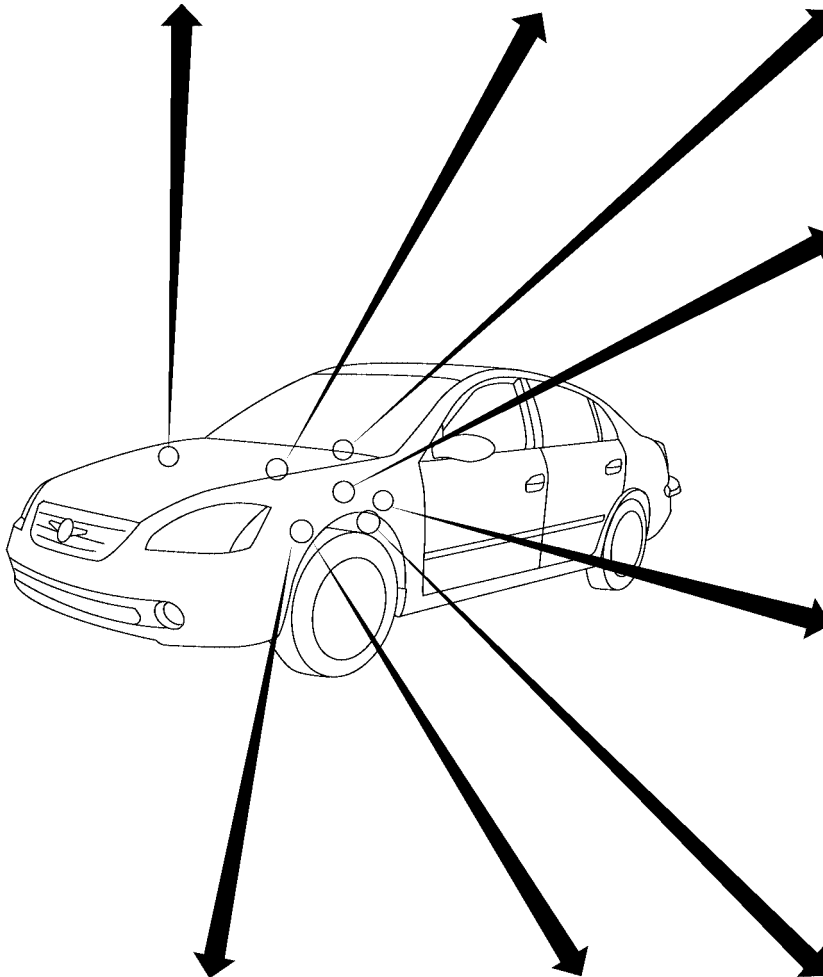
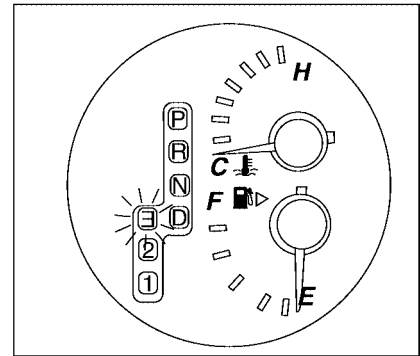
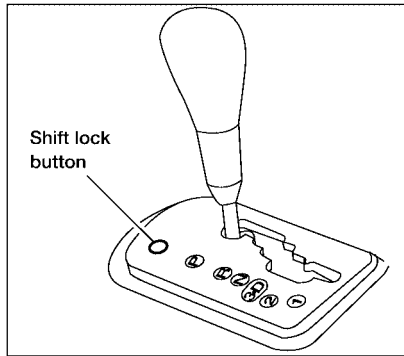
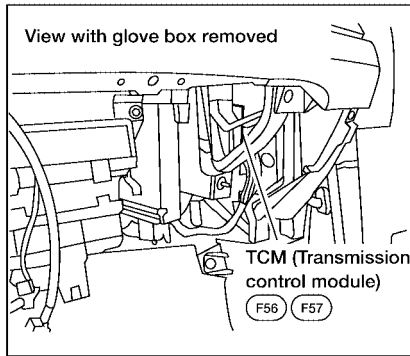

LCIA0291E

OVERALL SYSTEM

Circuit Diagram

ECS006A6

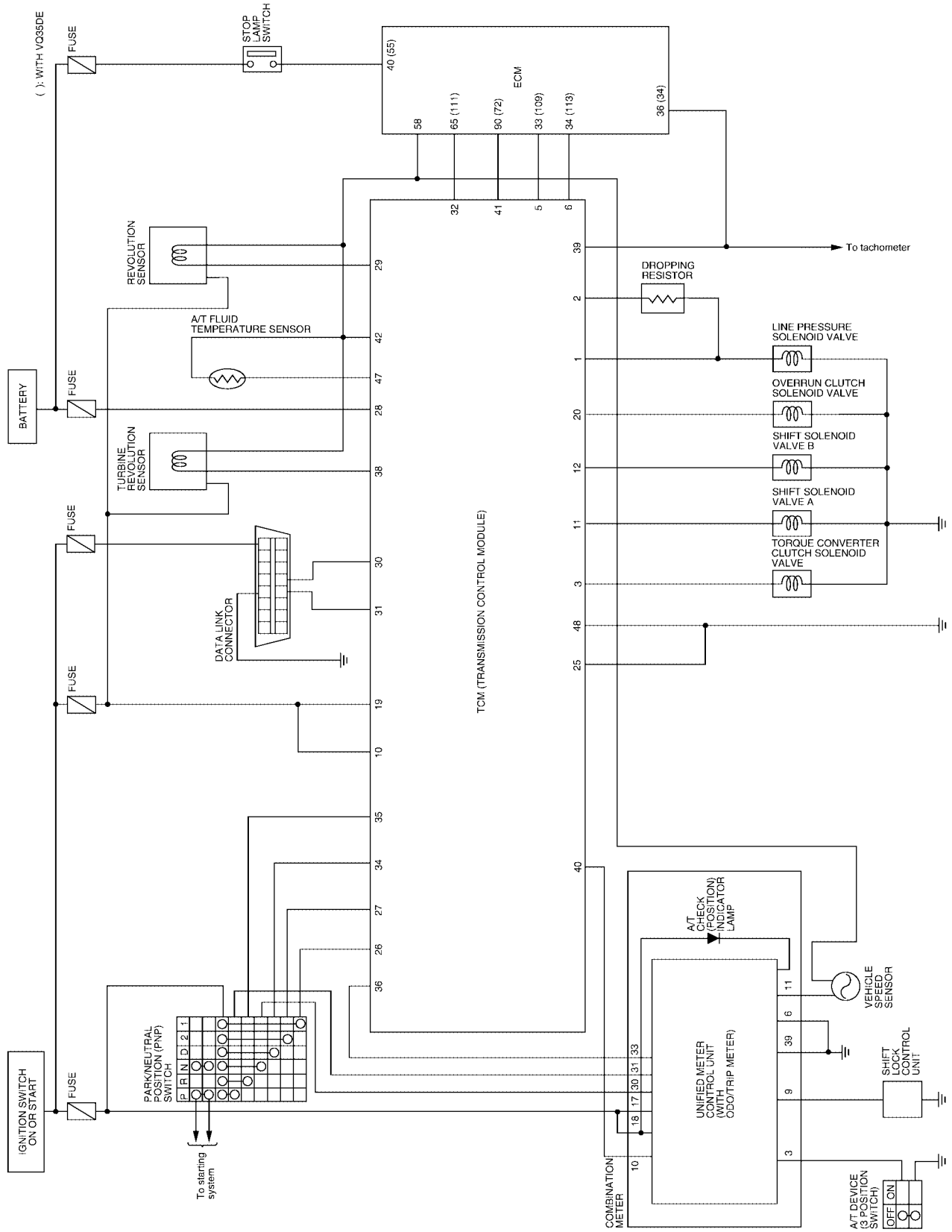

WCWA0044E

OVERALL SYSTEM

Cross-sectional View

ECS006A7

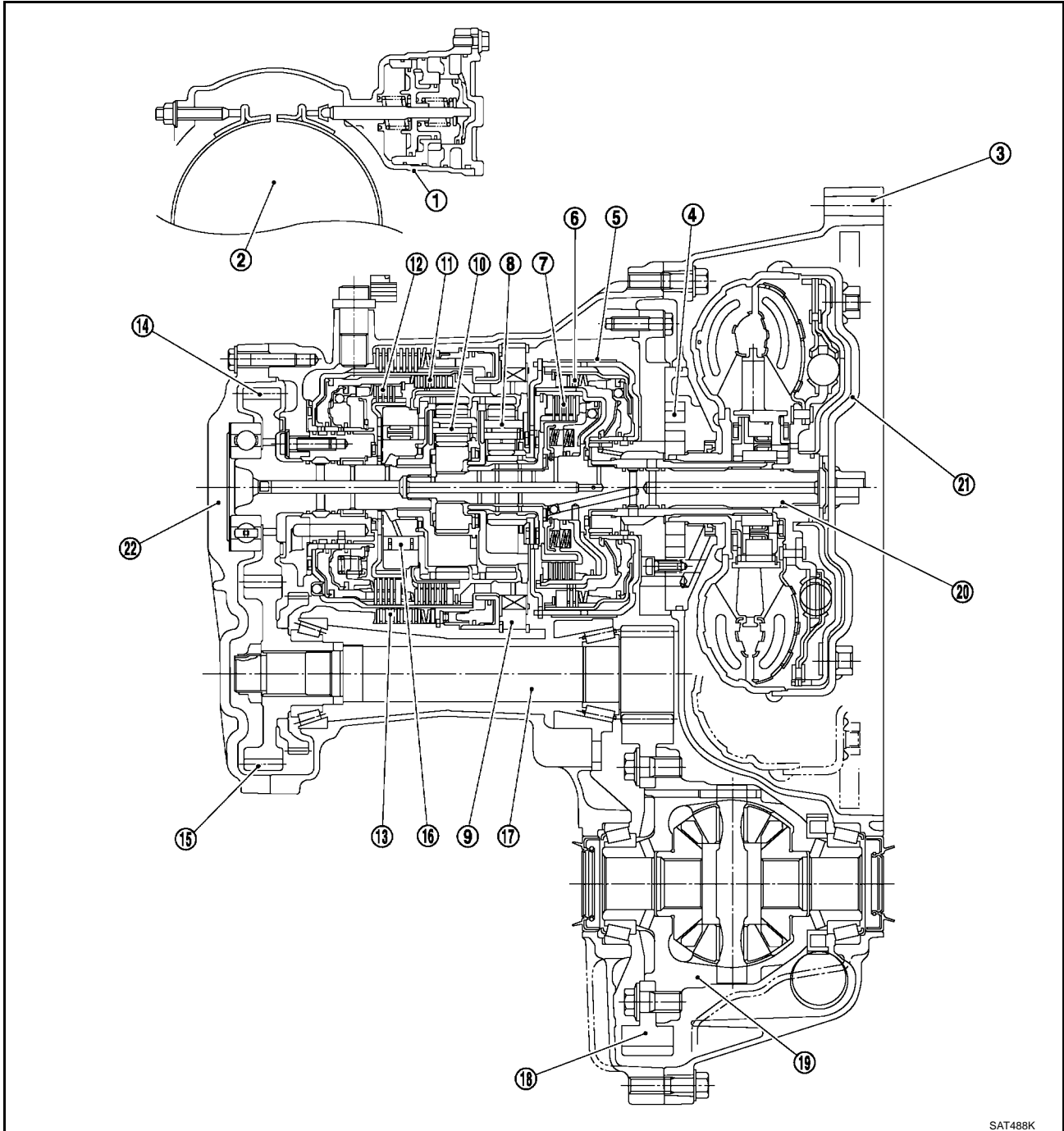

A
B
AT
D
E
F
G
H
I
J
K
L
M

- | | | |
|----------------------------|---------------------------|-----------------------|
| 1. Band servo piston | 2. Reverse clutch drum | 3. Converter housing |
| 4. Oil pump | 5. Brake band | 6. Reverse clutch |
| 7. High clutch | 8. Front planetary gear | 9. Low one-way clutch |
| 10. Rear planetary gear | 11. Forward clutch | 12. Overrun clutch |
| 13. Low & reverse brake | 14. Output gear | 15. Idler gear |
| 16. Forward one-way clutch | 17. Pinion reduction gear | 18. Final gear |
| 19. Differential case | 20. Input shaft | 21. Torque converter |
| 22. Side cover | | |

SAT488K

OVERALL SYSTEM

Hydraulic Control Circuit

ECS006A8

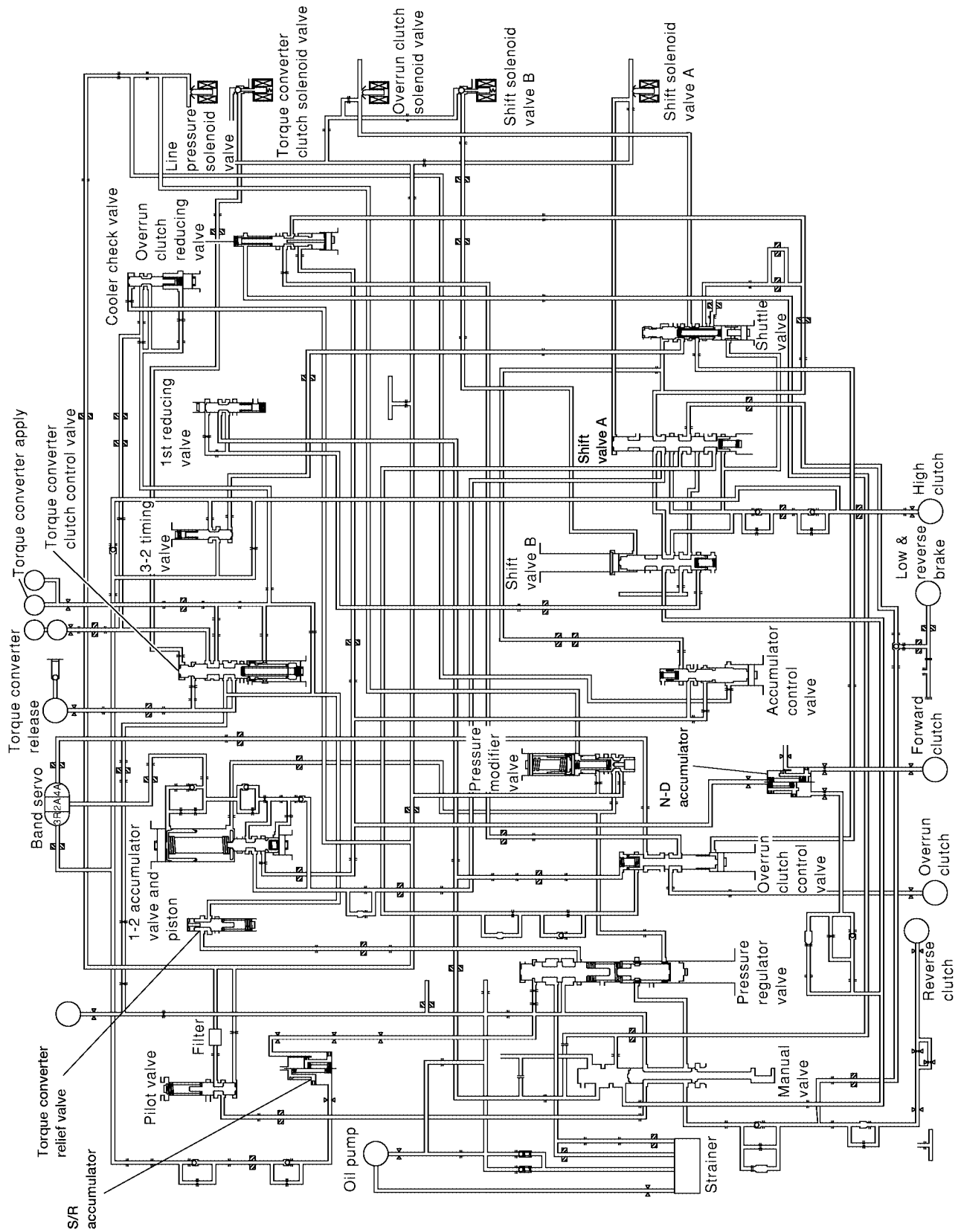

LCIA0040E

OVERALL SYSTEM

ECS006A9

Shift Mechanism CONSTRUCTION

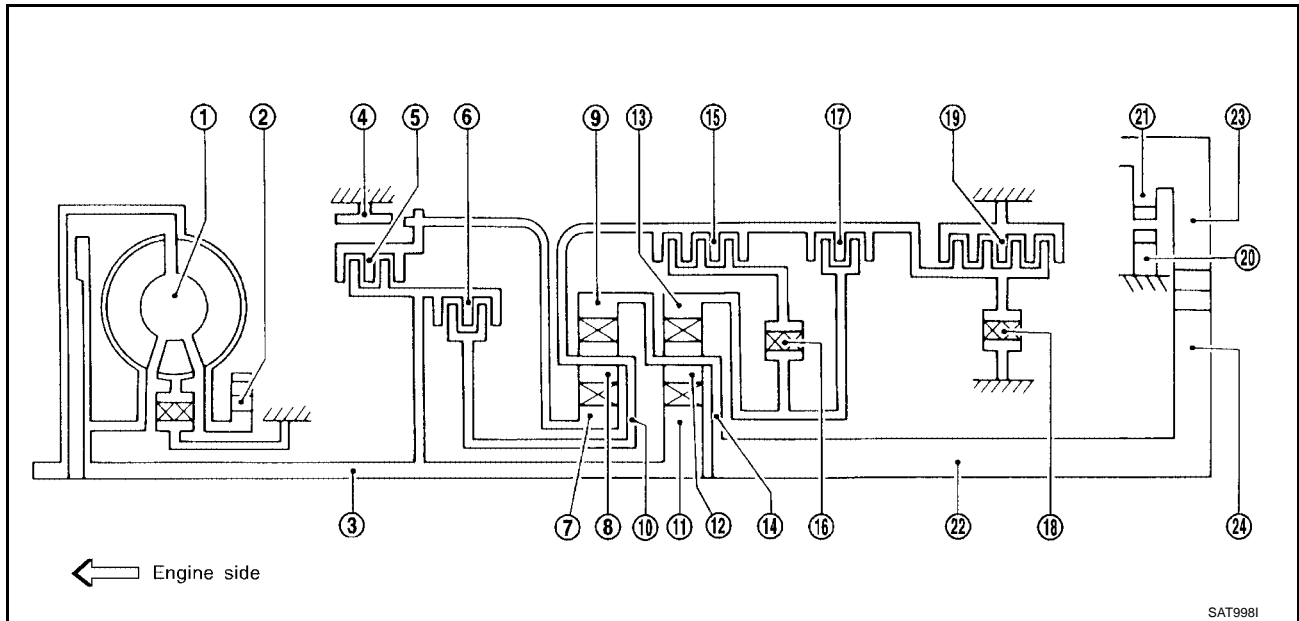

- | | | |
|-----------------------------|----------------------------|------------------------|
| 1. Torque converter | 2. Oil pump | 3. Input shaft |
| 4. Brake band | 5. Reverse clutch | 6. High clutch |
| 7. Front sun gear | 8. Front pinion gear | 9. Front internal gear |
| 10. Front planetary carrier | 11. Rear sun gear | 12. Rear pinion gear |
| 13. Rear internal gear | 14. Rear planetary carrier | 15. Forward clutch |
| 16. Forward one-way clutch | 17. Overrun clutch | 18. Low one-way clutch |
| 19. Low & reverse brake | 20. Parking pawl | 21. Parking gear |
| 22. Output shaft | 23. Idle gear | 24. Output gear |

FUNCTION OF CLUTCH AND BRAKE

Clutch and brake components	Abbr.	Function
Reverse clutch 5	R/C	To transmit input power to front sun gear 7 .
High clutch 6	H/C	To transmit input power to front planetary carrier 10 .
Forward clutch 15	F/C	To connect front planetary carrier 10 with forward one-way clutch 16 .
Overrun clutch 17	O/C	To connect front planetary carrier 10 with rear internal gear 13 .
Brake band 4	B/B	To lock front sun gear 7 .
Forward one-way clutch 16	F/O.C	When forward clutch 15 is engaged, to stop rear internal gear 13 from rotating in opposite direction against engine revolution.
Low one-way clutch 18	L/O.C	To stop front planetary carrier 10 from rotating in opposite direction against engine revolution.
Low & reverse brake 19	L & R/B	To lock front planetary carrier 10 .

CLUTCH AND BAND CHART

Shift position	Re-verse clutch 5	High clutch 6	For-ward clutch 15	Over-run clutch 17	Band servo			For-ward one-way clutch 16	Low one-way clutch 18	Low & re-verse brake 19	Lock-up	Remarks
					2nd apply	3rd re-lease	4th apply					
P												PARK POSITION
R	O									O		REVERSE POSITION

OVERALL SYSTEM

Shift position	Re-verse clutch 5	High clutch 6	For-ward clutch 15	Over-run clutch 17	Band servo			For-ward one-way clutch 16	Low one-way clutch 18	Low & re-verse brake 19	Lock-up	Remarks
					2nd apply	3rd re-lease	4th apply					
N												NEUTRAL POSITION
D*4	1st		O	*1D				B	B			Automatic shift 1 ↔ 2 ↔ 3 ↔ 4
	2nd		O	*1 A	O			B				
	3rd		O	O	*1 A	*2C	C	B			*5O	
	4th		O	C		*3C	C	O			O	
2	1st		O	D				B	B			Automatic shift 1 ↔ 2 ↔ 3
	2nd		O	A	O			B				
1	1st		O	O				B		O		Locks (held stationary) in 1st speed 1 ↔ 2 ↔ 3
	2nd		O	O	O			B				

*1: Operates when selector lever is set in 3 position.

*2: Oil pressure is applied to both 2nd “apply” side and 3rd “release” side of band servo piston. However, brake band does not contract because oil pressure area on the “release” side is greater than that on the “apply” side.

*3: Oil pressure is applied to 4th “apply” side in condition *2 above, and brake band contracts.

*4: A/T will not shift to 4th when selector lever is set in 3 position.

*5: Operates when selector lever is set in 3 position.

O: Operates

A: Operates when throttle opening is less than 3/16, activating engine brake.

B: Operates during “progressive” acceleration.

C: Operates but does not affect power transmission.

D: Operates when throttle opening is less than 3/16, but does not affect engine brake.

OVERALL SYSTEM

POWER TRANSMISSION

P and N Positions

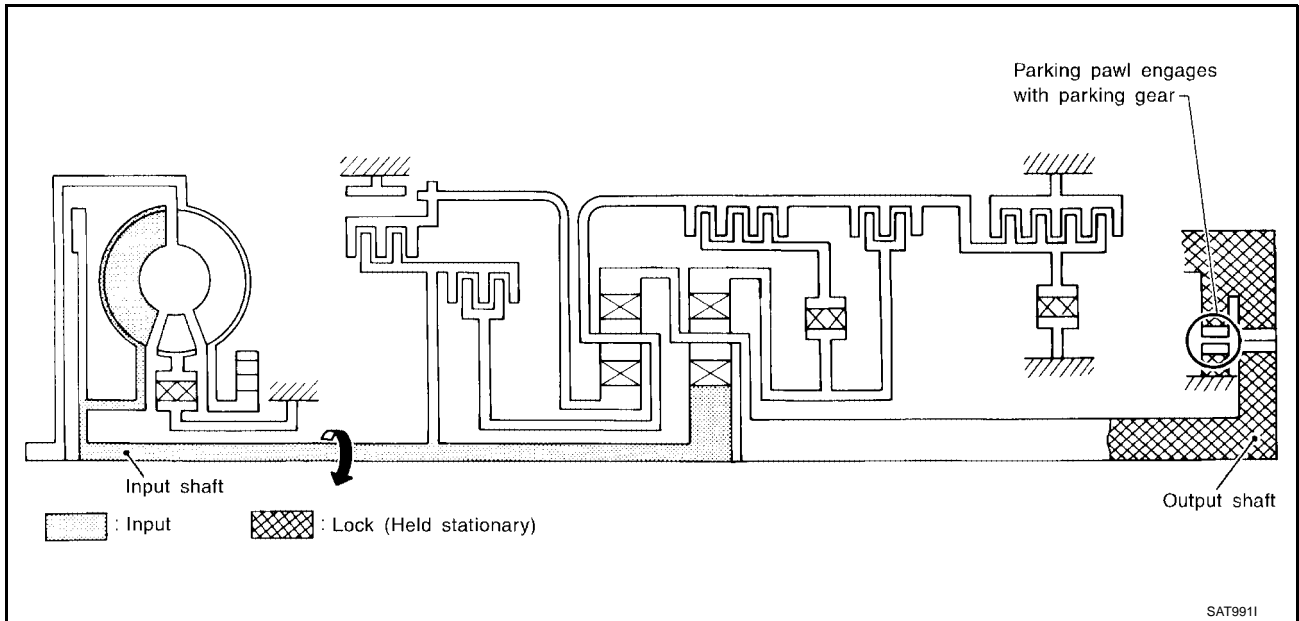

- P position
Similar to the N position, the clutches do not operate. The parking pawl engages with the parking gear to mechanically hold the output shaft so that the power train is locked.
- N position
Power from the input shaft is not transmitted to the output shaft because the clutches do not operate.

OVERALL SYSTEM

11 Position

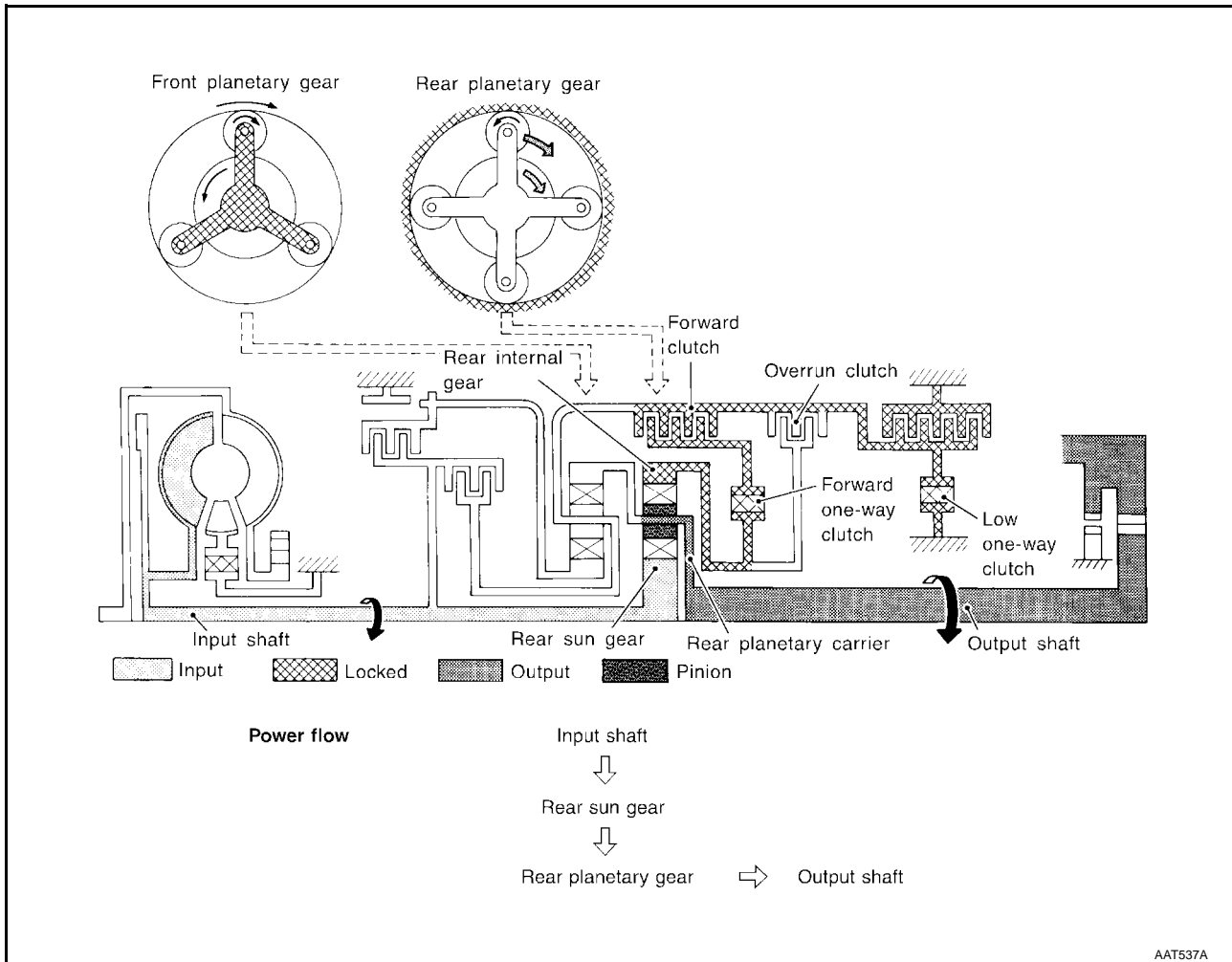

<ul style="list-style-type: none"> ● Forward clutch ● Forward one-way clutch ● Overrun clutch ● Low and reverse brake 	<p>As overrun clutch engages, rear internal gear is locked by the operation of low and reverse brake. This is different from that of D1 , 21 , and 31 .</p>
<p>Engine brake</p>	<p>Overrun clutch always engages, therefore engine brake can be obtained when decelerating.</p>

OVERALL SYSTEM

D1 and 21 Positions

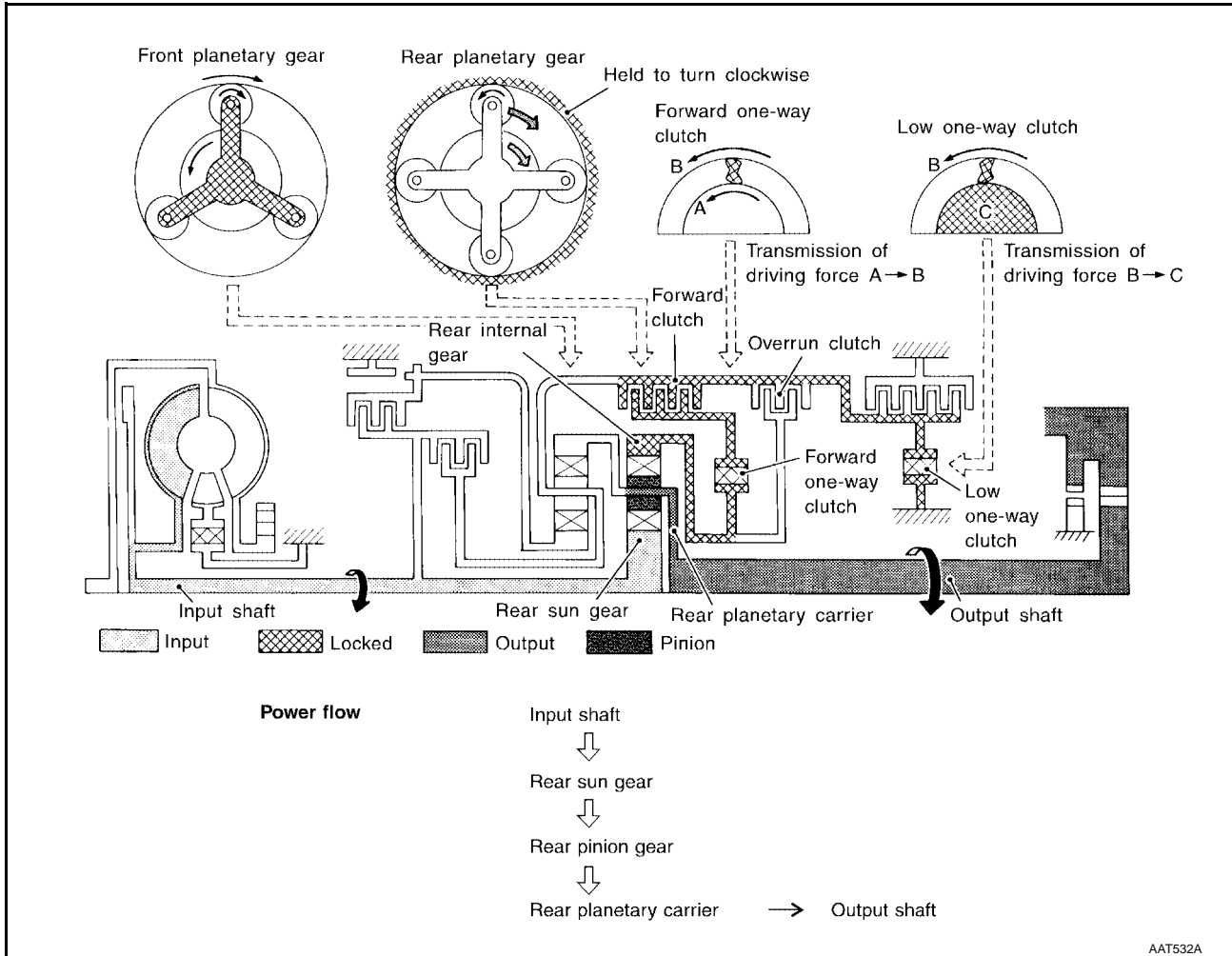

<ul style="list-style-type: none"> ● Forward one-way clutch ● Forward clutch ● Low one-way clutch 	Rear internal gear is locked to rotate counterclockwise because of the functioning of these three clutches.
Overrun clutch engagement conditions (Engine brake)	D1 : Overdrive control switch OFF and throttle opening is less than 3/16 21 : Always engaged At D1 and 21 positions, engine brake is not activated due to free turning of low one-way clutch.

OVERALL SYSTEM

D2 , 32 , 22 and 12 Positions

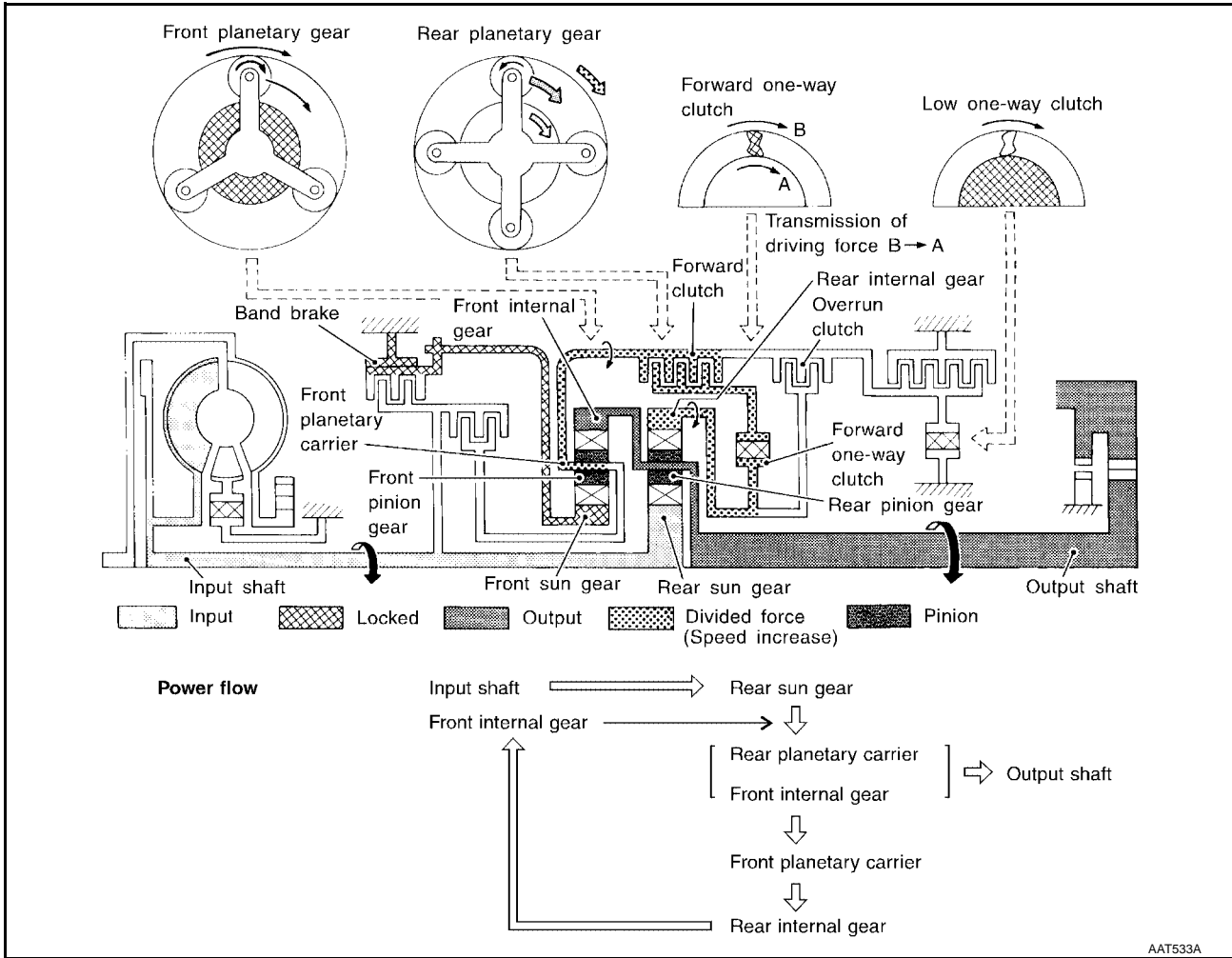

AAT533A

<ul style="list-style-type: none"> ● Forward clutch ● Forward one-way clutch ● Brake band 	<p>Rear sun gear drives rear planetary carrier and combined front internal gear. Front internal gear now rotates around front sun gear accompanying front planetary carrier. As front planetary carrier transfers the power to rear internal gear through forward clutch and forward one-way clutch, this rotation of rear internal gear increases the speed of rear planetary carrier compared with that of the 1st speed.</p>
<p>Overrun clutch engagement conditions</p>	<p>32 : Gear selector lever is set in 3 position and throttle opening is less than 3/16 32 , 22 and 12 : Always engaged</p>

OVERALL SYSTEM

D3 and 33 Positions

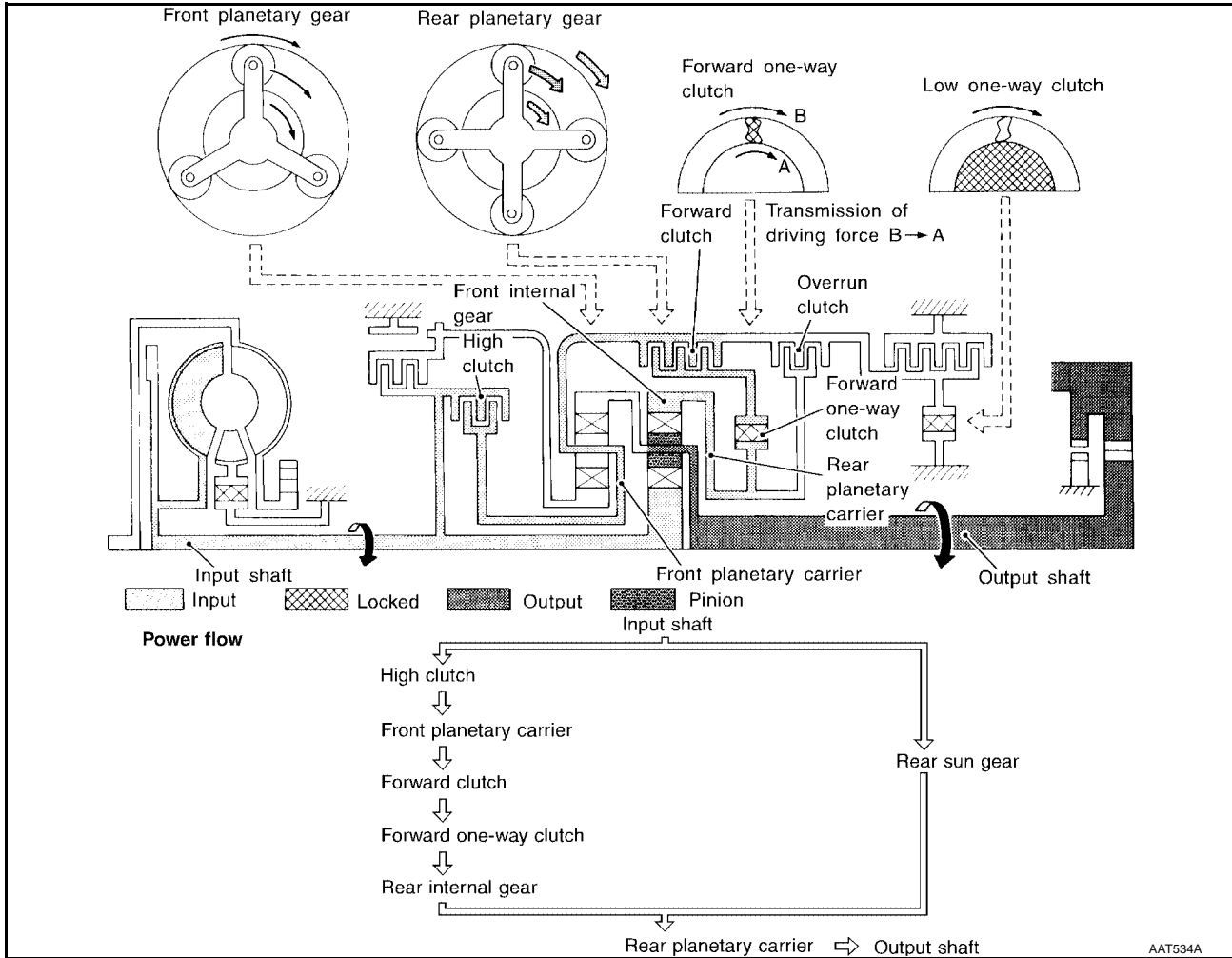

<ul style="list-style-type: none"> ● High clutch ● Forward clutch ● Forward one-way clutch 	<p>Input power is transmitted to front planetary carrier through high clutch. And front planetary carrier is connected to rear internal gear by operation of forward clutch and forward one-way clutch.</p> <p>This rear internal gear rotation and another input (the rear sun gear) accompany rear planetary carrier to turn at the same speed.</p>
<p>Overrun clutch engagement conditions</p>	<p>D3 and 33 : Selector lever is set in 3 position and throttle opening is less than 3/16</p>

OVERALL SYSTEM

D4 Position

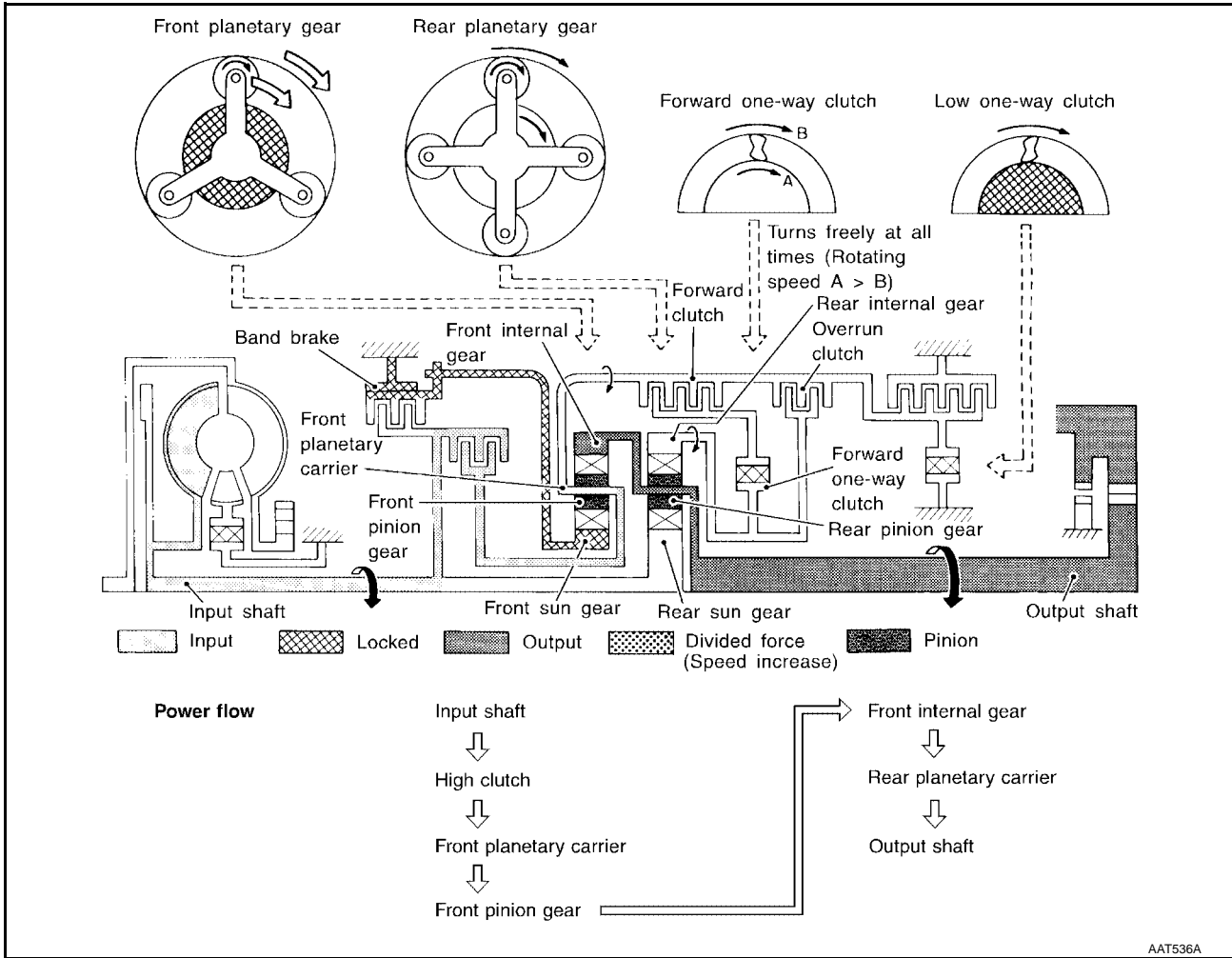

AAT536A

<ul style="list-style-type: none"> ● High clutch ● Brake band ● Forward clutch (Does not affect power transmission) 	<p>Input power is transmitted to front carrier through high clutch. This front carrier turns around the sun gear which is fixed by brake band and makes front internal gear (output) turn faster.</p>
<p>Engine brake</p>	<p>At D4 position, there is no one-way clutch in the power transmission line and engine brake can be obtained when decelerating.</p>

OVERALL SYSTEM

R Position

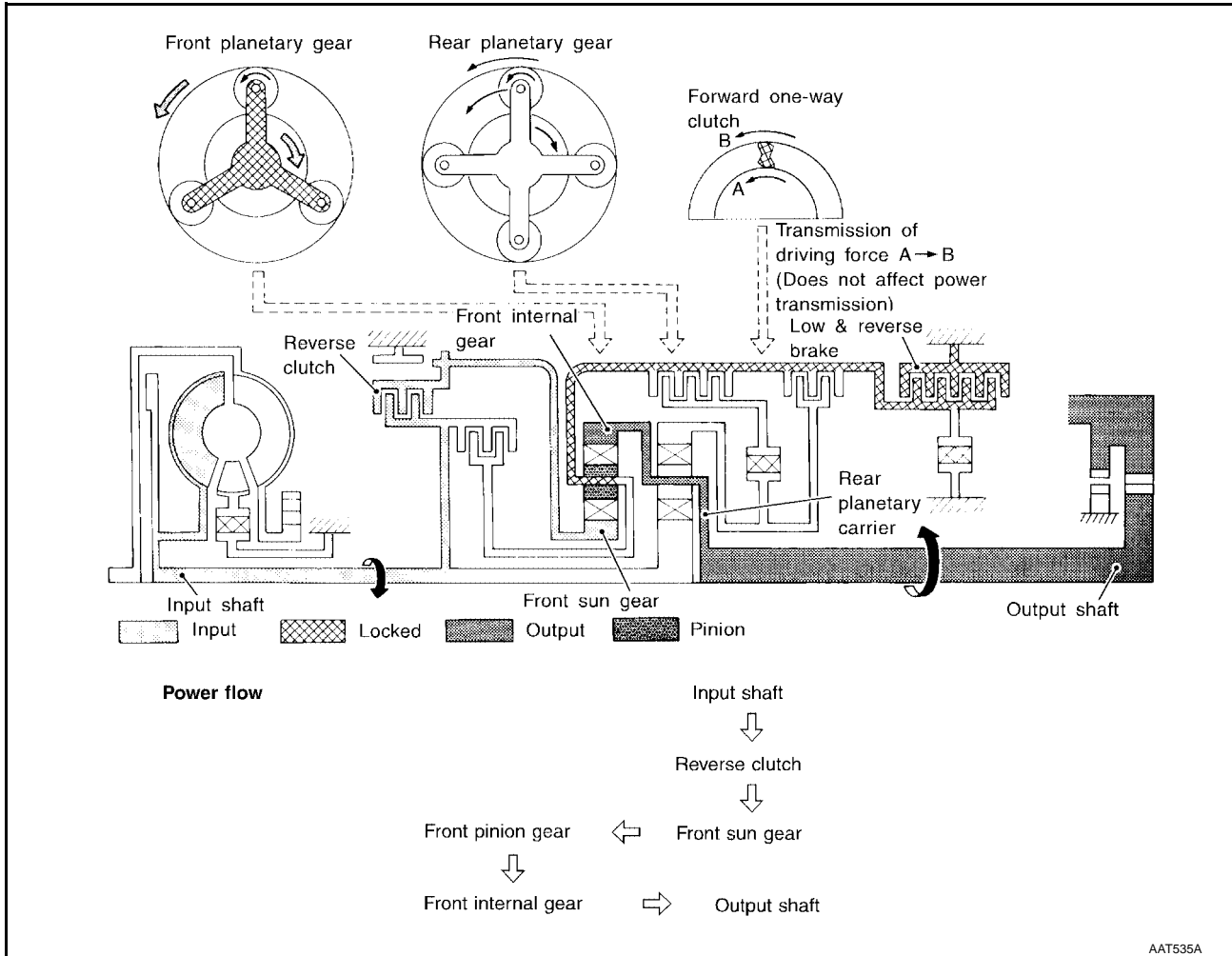

AAT535A

<ul style="list-style-type: none"> ● Reverse clutch ● Low and reverse brake 	<p>Front planetary carrier is stationary because of the operation of low and reverse brake. Input power is transmitted to front sun gear through reverse clutch, which drives front internal gear in the opposite direction.</p>
<p>Engine brake</p>	<p>As there is no one-way clutch in the power transmission line, engine brake can be obtained when decelerating.</p>

OVERALL SYSTEM

ECS006AA

Control System OUTLINE

The automatic transaxle senses vehicle operating conditions through various sensors. It always controls the optimum shift position and reduces shifting and lock-up shocks.

SENSORS		TCM		ACTUATORS
Park/neutral position (PNP) switch Throttle position sensor [accelerator pedal position (APP) sensor] Engine speed signal A/T fluid temperature sensor Revolution sensor (VHCL/S SE-1) Vehicle speed sensor (VHCL/S SE-2) 3 position switch ASCD control unit Stop lamp switch Turbine revolution sensor	▶	Shift control Line pressure control Lock-up control Overrun clutch control Timing control Fail-safe control Self-diagnosis CAN communication line control	▶	Shift solenoid valve A Shift solenoid valve B Overrun clutch solenoid valve Torque converter clutch solenoid valve Line pressure solenoid valve A/T check (position) indicator lamp

CONTROL SYSTEM

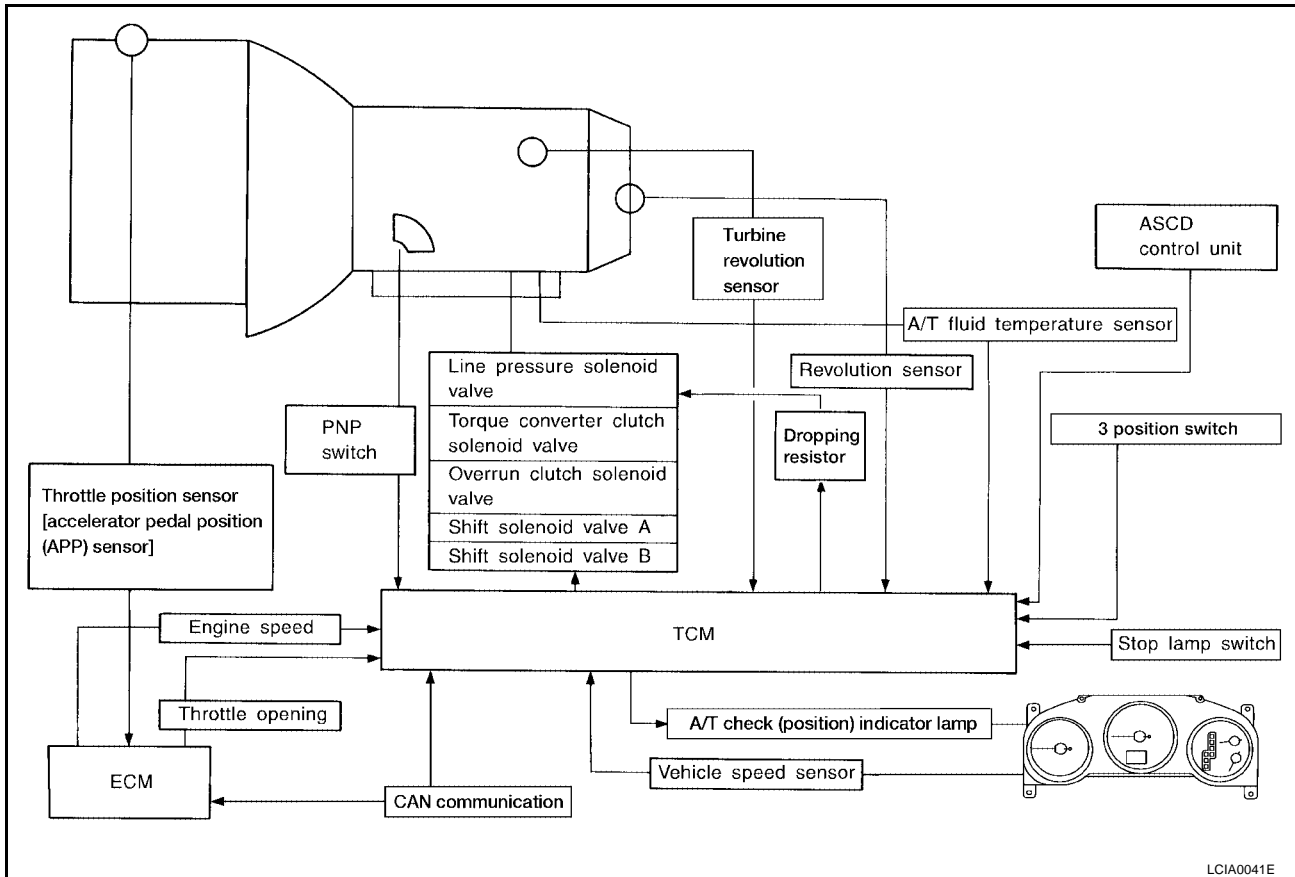

OVERALL SYSTEM

TCM FUNCTION

The function of the TCM is to:

- Receive input signals sent from various switches and sensors.
- Determine required line pressure, shifting point, lock-up operation, and engine brake operation.
- Send required output signals to the respective solenoids.

INPUT/OUTPUT SIGNAL OF TCM

	Sensors and solenoid valves	Function
Input	Park/neutral position (PNP) switch	Detects select lever position and sends a signal to TCM.
	Throttle position sensor [accelerator pedal position (APP) sensor]	Detects throttle valve position and sends a signal to TCM.
	Engine speed signal	Receives signal from ECM and controls lock-up control solenoid valve.
	A/T fluid temperature sensor	Detects transmission fluid temperature and sends a signal to TCM.
	Revolution sensor (VHCL/S SE-1)	Detects output shaft rpm and sends a signal to TCM.
	Vehicle speed sensor (VHCL/S SE-2)	Used as an auxiliary vehicle speed sensor. Sends a signal when revolution sensor (installed on transmission) malfunctions.
	3 position switch	Sends a signal, which prohibits a shift to D4 (overdrive) position, to the TCM.
	ASCD control unit	Sends the cruise signal and D4 (overdrive) cancellation signal from ASCD control unit to TCM.
	Stop lamp switch	Send the lock-up release signal to the TCM at time of D4 (lock-up).
	CAN communication	In CAN communication, control units are connected to 2 communication lines (CAN H line, CAN L line) allowing a high rate of information transmission with less wiring.
Output	Shift solenoid valve A/B	Selects shifting point suited to driving conditions in relation to a signal sent from TCM.
	Line pressure solenoid valve	Regulates (or decreases) line pressure suited to driving conditions in relation to a signal sent from TCM.
	Torque converter clutch solenoid valve	Regulates (or decreases) lock-up pressure suited to driving conditions in relation to a signal sent from TCM.
	Overrun clutch solenoid valve	Controls an "engine brake" effect suited to driving conditions in relation to a signal sent from TCM.
	A/T check (position) indicator lamp	Shows TCM faults, when A/T control components malfunction.
	CAN communication	In CAN communication, control units are connected to 2 communication lines (CAN H line, CAN L line) allowing a high rate of information transmission with less wiring.

OVERALL SYSTEM

ECS006AB

Control Mechanism LINE PRESSURE CONTROL

TCM has various line pressure control characteristics to meet the driving conditions. An ON-OFF duty signal is sent to the line pressure solenoid valve based on TCM characteristics. Hydraulic pressure on the clutch and brake is electronically controlled through the line pressure solenoid valve to accommodate engine torque. This results in smooth shift operation.

Normal Control

The line pressure to throttle opening characteristics is set for suitable clutch operation.

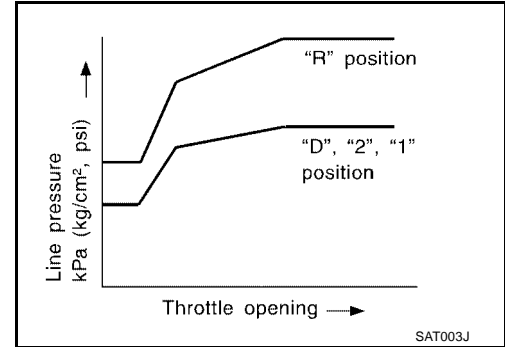

Back-up Control (Engine brake)

If the selector lever is shifted to 2 position while driving in D4 (O/D) or D3, great driving force is applied to the clutch inside the transmission. Clutch operating pressure (line pressure) must be increased to deal with this driving force.

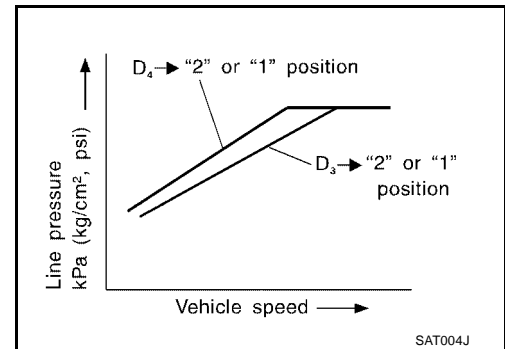

During Shift Change

The line pressure is temporarily reduced corresponding to a change in engine torque when shifting gears (that is, when the shift solenoid valve is switched for clutch operation) to reduce shifting shock.

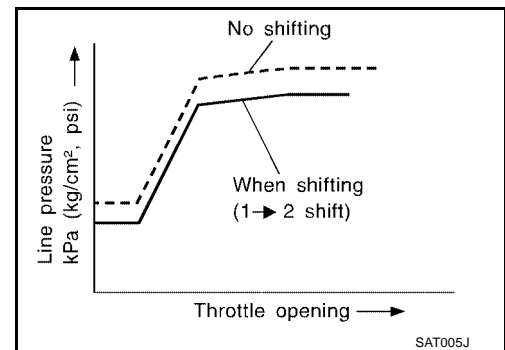

At Low Fluid Temperature

- Fluid viscosity and frictional characteristics of the clutch facing change with fluid temperature. Clutch engaging or band-contacting pressure is compensated for, according to fluid temperature, to stabilize shifting quality.

OVERALL SYSTEM

- The line pressure is reduced below 60°C (140°F) to prevent shifting shock due to low viscosity of automatic transmission fluid when temperature is low.

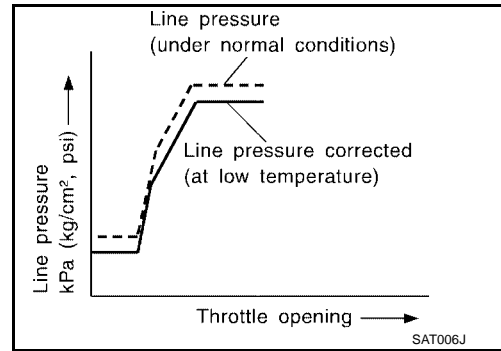

- Line pressure is increased to a maximum irrespective of the throttle opening when fluid temperature drops to -10°C (14°F). This pressure rise is adopted to prevent a delay in clutch and brake operation due to extreme drop of fluid viscosity at low temperature.

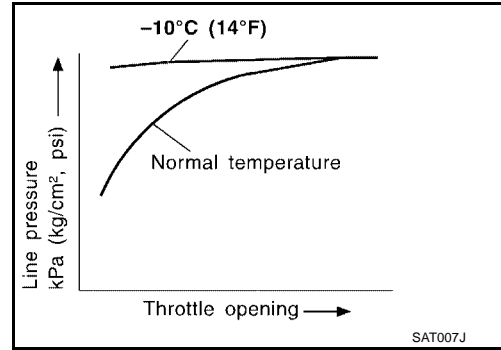

SHIFT CONTROL

The shift is regulated entirely by electronic control to accommodate vehicle speed and varying engine operations. This is accomplished by electrical signals transmitted by the revolution sensor and the ECM (throttle opening). This results in improved acceleration performance and fuel economy.

Control of Shift Solenoid Valves A and B

The shift solenoid valve performs simple ON-OFF operation. When set to ON, the drain circuit closes and pilot pressure is applied to the shift valve.

The TCM activates shift solenoid valves A and B according to signals from the ECM (throttle opening) and revolution sensor to select the optimum gear position on the basis of the shift schedule memorized in the TCM.

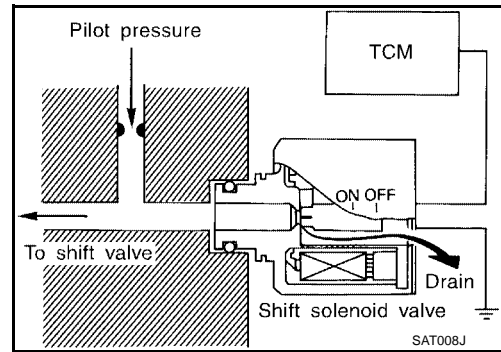

OVERALL SYSTEM

Relation between shift solenoid valves A and B and gear positions

Shift solenoid valve	Gear position				
	D1 , 21 , 11	D2 , 22 , 12	D3	D4 (O/D)	N-P
A	ON (Closed)	OFF (Open)	OFF (Open)	ON (Closed)	ON (Closed)
B	ON (Closed)	ON (Closed)	OFF (Open)	OFF (Open)	ON (Closed)

Control of Shift Valves A and B

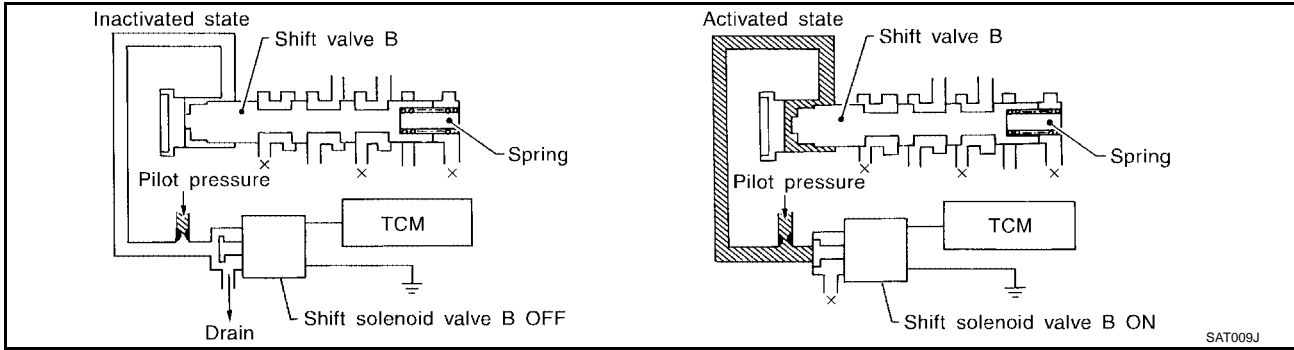

Pilot pressure generated by the operation of shift solenoid valves A and B is applied to the end face of shift valves A and B.

The drawing above shows the operation of shift valve B. When the shift solenoid valve is ON, pilot pressure applied to the end face of the shift valve overcomes spring force, moving the valve upward.

LOCK-UP CONTROL

The torque converter clutch piston in the torque converter is locked to eliminate torque converter slip to increase power transmission efficiency. The solenoid valve is controlled by an ON-OFF duty signal sent from the TCM. The signal is converted to an oil pressure signal which controls the lock-up piston.

Conditions for Lock-up Operation

When vehicle is driven in 4th gear position, vehicle speed and throttle opening are detected. If the detected values fall within the lock-up zone memorized in the TCM, lock-up is performed.

Selector lever	D position	3 position
Gear position	D4	3
Vehicle speed sensor	More than set value	
ECM (throttle opening)	Less than set opening	
A/T fluid temperature sensor	More than 40°C (104°F)	

Torque Converter Clutch Solenoid Valve Control

The torque converter clutch solenoid valve is controlled by the TCM. The plunger closes the drain circuit during the OFF period, and opens the circuit during the ON period. If the percentage of OFF-time increases in one cycle, the pilot pressure drain time is reduced and pilot pressure remains high.

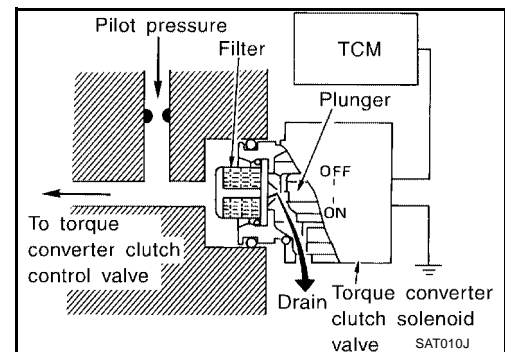

OVERALL SYSTEM

The torque converter clutch piston is designed to slip to adjust the ratio of ON-OFF, thereby reducing lock-up shock.
OFF-time INCREASING

↓
Amount of drain DECREASING

↓
Pilot pressure HIGH

↓
Lock-up RELEASING

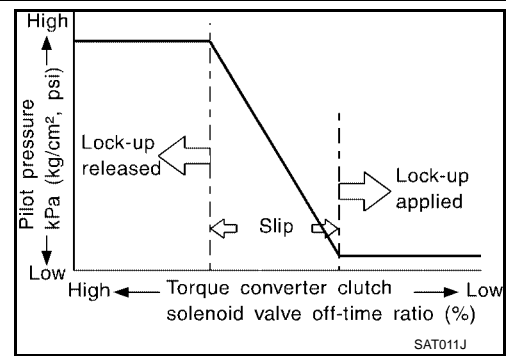

Torque Converter Clutch Control Valve Operation

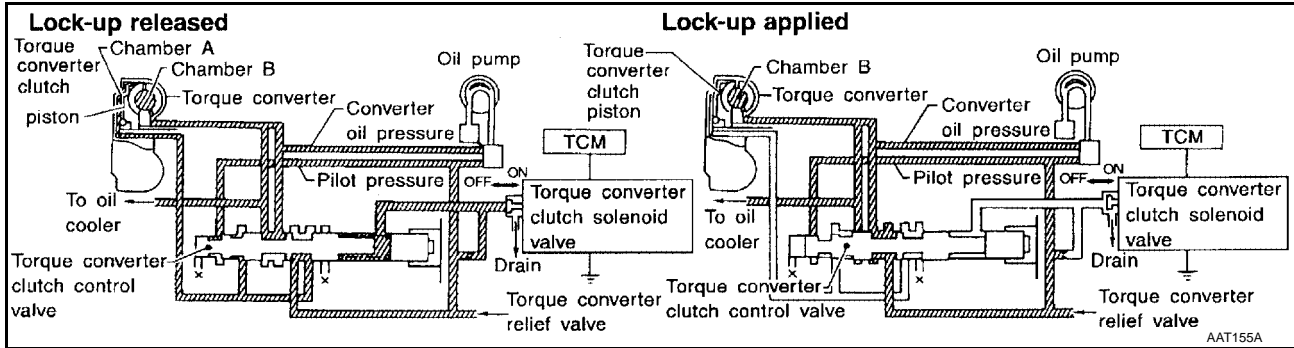

LOCK-UP RELEASED

The OFF-duration of the torque converter clutch solenoid valve is long, and pilot pressure is high. The pilot pressure pushes the end face of the torque converter clutch control valve in combination with spring force to move the valve to the left. As a result, converter pressure is applied to chamber A (torque converter clutch piston release side). Accordingly, the torque converter clutch piston remains unlocked.

LOCK-UP APPLIED

When the OFF-duration of the torque converter clutch solenoid valve is short, pilot pressure drains and becomes low. Accordingly, the control valve moves to the right by the pilot pressure of the other circuit and converter pressure. As a result, converter pressure is applied to chamber B, keeping the torque converter clutch piston applied.

Also smooth lock-up is provided by transient application and release of the lock-up.

OVERRUN CLUTCH CONTROL (ENGINE BRAKE CONTROL)

Forward one-way clutch is used to reduce shifting shocks in downshifting operations. This clutch transmits engine torque to the wheels. However, drive force from the wheels is not transmitted to the engine because the one-way clutch rotates idle. This means the engine brake is not effective.

The overrun clutch operates when the engine brake is needed.

Overrun Clutch Operating Conditions

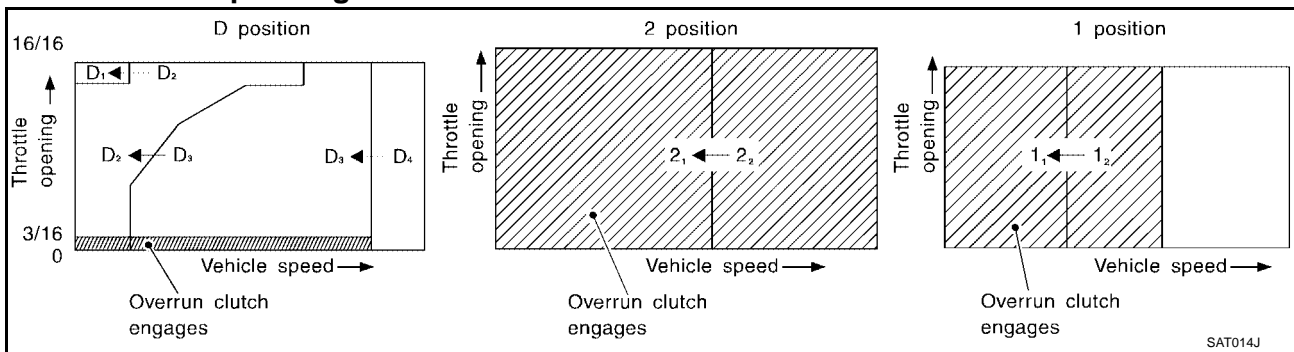

Selector lever position	Gear position	Throttle opening
D	D1, D2, D3	Less than 3/16
2	21, 22	
1	11, 12	At any position

OVERALL SYSTEM

Overrun Clutch Solenoid Valve Control

The overrun clutch solenoid valve is operated by an ON-OFF signal transmitted by the TCM to provide overrun clutch control (engine brake control).

When this solenoid valve is ON, the pilot pressure drain port closes. When it is OFF, the drain port opens.

During the solenoid valve ON pilot pressure is applied to the end face of the overrun clutch control valve.

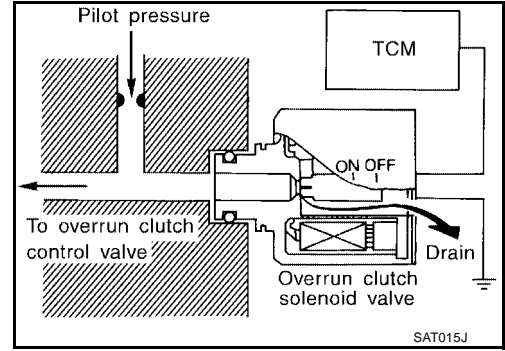

Overrun Clutch Control Valve Operation

When the solenoid valve is ON, pilot pressure is applied to the overrun clutch control valve. This pushes up the overrun clutch control valve. The line pressure is then shut off so that the clutch does not engage.

When the solenoid valve is OFF, pilot pressure is not generated. At this point, the overrun clutch control valve moves downward by spring force. As a result, overrun clutch operation pressure is provided by the overrun clutch reducing valve. This causes the overrun clutch to engage.

In the 1 position, the overrun clutch control valve remains pushed down so that the overrun clutch is engaged at all times.

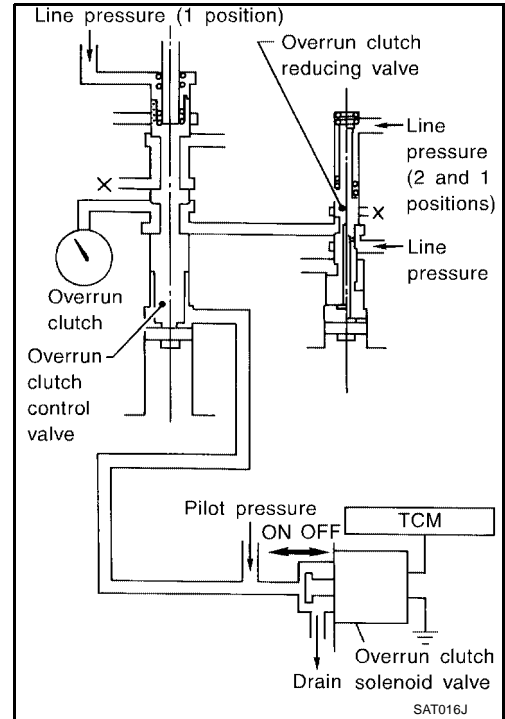

Control Valve

FUNCTION OF CONTROL VALVES

Valve name	Function
Pressure regulator valve, plug and sleeve plug	Regulates oil discharged from the oil pump to provide optimum line pressure for all driving conditions.
Pressure modifier valve and sleeve	Used as a signal supplementary valve to the pressure regulator valve. Regulates pressure-modifier pressure (signal pressure) which controls optimum line pressure for all driving conditions.
Pilot valve	Regulates line pressure to maintain a constant pilot pressure level which controls lock-up mechanism, overrun clutch, shift timing.
Accumulator control valve	Regulates accumulator back-pressure to pressure suited to driving conditions.
Manual valve	Directs line pressure to oil circuits corresponding to select positions. Hydraulic pressure drains when the shift lever is in Neutral.
Shift valve A	Simultaneously switches three oil circuits using output pressure of shift solenoid valve A to meet driving conditions (vehicle speed, throttle opening, etc.). Provides automatic downshifting and up-shifting (1st → 2nd → 3rd → 4th gears/4th → 3rd → 2nd → 1st gears) in combination with shift valve B.

ECS006AC

OVERALL SYSTEM

Valve name	Function
Shift valve B	Simultaneously switches two oil circuits using output pressure of shift solenoid valve B in relation to driving conditions (vehicle speed, throttle opening, etc.). Provides automatic downshifting and up-shifting (1st → 2nd → 3rd → 4th gears/4th → 3rd → 2nd → 1st gears) in combination with shift valve A.
Overrun clutch control valve	Switches hydraulic circuits to prevent engagement of the overrun clutch simultaneously with application of the brake band in D4 . (Interlocking occurs if the overrun clutch engages during D4 .)
"1" reducing valve	Reduces low & reverse brake pressure to dampen engine-brake shock when down-shifting from the 1 position 12 to 11 .
Overrun clutch reducing valve	Reduces oil pressure directed to the overrun clutch and prevents engine-brake shock. In 1 and 2 positions, line pressure acts on the overrun clutch reducing valve to increase the pressure-regulating point, with resultant engine brake capability.
Torque converter relief valve	Prevents an excessive rise in torque converter pressure.
Torque converter clutch control valve, plug and sleeve	Activates or inactivates the lock-up function. Also provides smooth lock-up through transient application and release of the lock-up system.
1-2 accumulator valve and piston	Dampens the shock encountered when 2nd gear band servo contracts, and provides smooth shifting.
3-2 timing valve	Switches the pace that oil pressure is released depending on vehicle speed; maximizes the high clutch release timing, and allows for soft down shifting.
Shuttle valve	Determines if the overrun clutch solenoid valve should control the 3-2 timing valve or the overrun clutch control valve and switches between the two.
Cooler check valve	At low speeds and with a small load when little heat is generated, saves the volume of cooler flow, and stores the oil pressure for lock up.

A
B
AT
D
E
F
G
H
I
J
K
L
M

ON BOARD DIAGNOSTIC SYSTEM DESCRIPTION

ON BOARD DIAGNOSTIC SYSTEM DESCRIPTION

PFP:00000

Introduction

ECS006AD

The A/T system has two self-diagnostic systems.

The first is the emission-related on board diagnostic system (OBD-II) performed by the TCM (transmission control module) in combination with the ECM. The malfunction is indicated by the MIL (malfunction indicator lamp) and is stored as a DTC in the ECM memory but not the TCM memory.

The second is the TCM original self-diagnosis indicated by the A/T check (position) indicator lamp. The malfunction is stored in the TCM memory. The detected items are overlapped with OBD-II self-diagnostic items. For details, refer to [AT-36, "OBD-II Function for A/T System"](#).

OBD-II Function for A/T System

ECS006AE

The ECM provides emission-related on board diagnostic (OBD-II) functions for the A/T system. One function is to receive a signal from the TCM used with OBD-related parts of the A/T system. The signal is sent to the ECM when a malfunction occurs in the corresponding OBD-related part. The other function is to indicate a diagnostic result by means of the MIL (malfunction indicator lamp) on the instrument panel. Sensors, switches and solenoid valves are used as sensing elements.

The MIL automatically illuminates in One or Two Trip Detection Logic when a malfunction is sensed in relation to A/T system parts.

One or Two Trip Detection Logic of OBD-II

ECS006AF

ONE TRIP DETECTION LOGIC

If a malfunction is sensed during the first test drive, the MIL will illuminate and the malfunction will be stored in the ECM memory as a DTC. The TCM is not provided with such a memory function.

TWO TRIP DETECTION LOGIC

When a malfunction is sensed during the first test drive, it is stored in the ECM memory as a 1st trip DTC (diagnostic trouble code) or 1st trip freeze frame data. At this point, the MIL will not illuminate. — First Trip

If the same malfunction as that experienced during the first test drive is sensed during the second test drive, the MIL will illuminate. — Second Trip

A/T-related parts for which the MIL illuminates during the first or second test drive are listed below.

Items	MIL	
	One trip detection	Two trip detection
Shift solenoid valve A — DTC: P0750	X	
Shift solenoid valve B — DTC: P0755	X	
Accelerator pedal position (APP) sensor — DTC: P1705	X	
Except above		X



The "trip" in the "One or Two Trip Detection Logic" means a driving mode in which self-diagnosis is performed during vehicle operation.

OBD-II Diagnostic Trouble Code (DTC)

ECS006AG

HOW TO READ DTC AND 1ST TRIP DTC

DTC and 1st trip DTC can be read by the following methods.

( **With CONSULT-II** or ( **GST**) CONSULT-II or GST (Generic Scan Tool) Examples: P0705, P0710, P0720, P0725, etc.

These DTCs are prescribed by SAE J2012.

(CONSULT-II also displays the malfunctioning component or system.)

- **1st trip DTC No. is the same as DTC No.**
- **Output of the diagnostic trouble code indicates that the indicated circuit has a malfunction. However, in case of the Mode II and GST they do not indicate whether the malfunction is still occurring or occurred in the past and returned to normal. CONSULT-II can identify them as shown below. Therefore, using CONSULT-II (if available) is recommended.**

ON BOARD DIAGNOSTIC SYSTEM DESCRIPTION

A sample of CONSULT-II display for DTC and 1st trip DTC is shown in the following page. DTC or 1st trip DTC of a malfunction is displayed in "SELF DIAGNOSIS" mode for "ENGINE" with CONSULT-II. Time data indicates how many times the vehicle was driven after the last detection of a DTC.

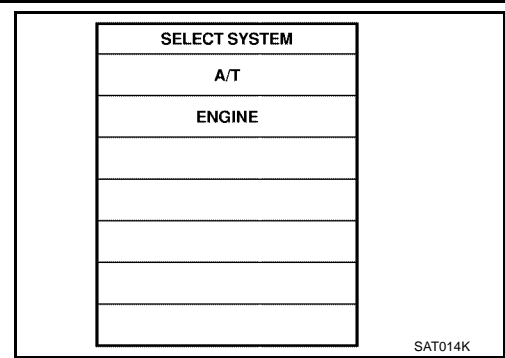

A
B
AT

If the DTC is being detected currently, the time data will be "0".

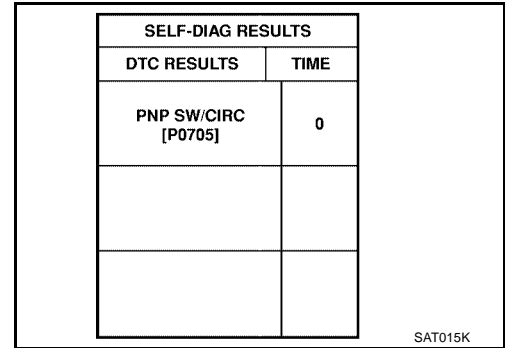

D
E
F
G

If a 1st trip DTC is stored in the ECM, the time data will be "1t".

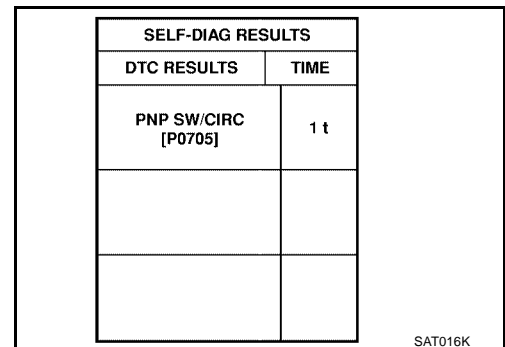

H
I
J
K

Freeze Frame Data and 1st Trip Freeze Frame Data

The ECM has a memory function, which stores the driving condition such as fuel system status, calculated load value, engine coolant temperature, short term fuel trim, long term fuel trim, engine speed and vehicle speed at the moment the ECM detects a malfunction.

Data which are stored in the ECM memory, along with the 1st trip DTC, are called 1st trip freeze frame data, and the data, stored together with the DTC data, are called freeze frame data and displayed on CONSULT-II or GST. The 1st trip freeze frame data can only be displayed on the CONSULT-II screen, not on the GST. For details, refer to [EC-57, "FREEZE FRAME DATA AND 1ST TRIP FREEZE FRAME DATA"](#) (with QR25DE) or [EC-682, "FREEZE FRAME DATA AND 1ST TRIP FREEZE FRAME DATA"](#) (with VQ35DE).

Only one set of freeze frame data (either 1st trip freeze frame data or freeze frame data) can be stored in the ECM. 1st trip freeze frame data is stored in the ECM memory along with the 1st trip DTC. There is no priority for 1st trip freeze frame data and it is updated each time a different 1st trip DTC is detected. However, once freeze frame data (2nd trip detection/MIL on) is stored in the ECM memory, 1st trip freeze frame data is no longer stored. Remember, only one set of freeze frame data can be stored in the ECM. The ECM has the following priorities to update the data.

L
M

Priority	Items	
1	Freeze frame data	Misfire — DTC: P0300 - P0306 Fuel Injection System Function — DTC: P0171, P0172, P0174, P0175
2		Except the above items (Includes A/T related items)
3	1st trip freeze frame data	

ON BOARD DIAGNOSTIC SYSTEM DESCRIPTION

Both 1st trip freeze frame data and freeze frame data (along with the DTCs) are cleared when the ECM memory is erased.

HOW TO ERASE DTC

The diagnostic trouble code can be erased by CONSULT-II, GST or ECM DIAGNOSTIC TEST MODE as described following.

- **If the battery terminal is disconnected, the diagnostic trouble code will be lost within 24 hours.**
- **When you erase the DTC, using CONSULT-II or GST is easier and quicker than switching the mode selector on the ECM.**

The following emission-related diagnostic information is cleared from the ECM memory when erasing DTC related to OBD-II. For details, refer to [EC-54, "Emission-related Diagnostic Information"](#) (with QR25DE), or [EC-678, "Emission-related Diagnostic Information"](#) (with VQ35DE).

- **Diagnostic trouble codes (DTC)**
- **1st trip diagnostic trouble codes (1st trip DTC)**
- **Freeze frame data**
- **1st trip freeze frame data**
- **System readiness test (SRT) codes**
- **Test values**

HOW TO ERASE DTC (WITH CONSULT-II)

- **If a DTC is displayed for both ECM and TCM, it needs to be erased for both ECM and TCM.**
1. If the ignition switch stays ON after repair work, be sure to turn ignition switch OFF once. Wait at least 10 seconds and then turn it ON (engine stopped) again.
 2. Turn CONSULT-II "ON" and touch "A/T".
 3. Touch "SELF-DIAG RESULTS".
 4. Touch "ERASE". (The DTC in the TCM will be erased.) Then touch "BACK" twice.
 5. Touch "ENGINE".
 6. Touch "SELF DIAGNOSIS".

ON BOARD DIAGNOSTIC SYSTEM DESCRIPTION

7. Touch "ERASE". (The DTC in the ECM will be erased.)

How to erase DTC (With CONSULT-II)

1. If the ignition switch stays ON after repair work, be sure to turn ignition switch OFF once. Wait at least 10 seconds and then turn it ON (engine stopped) again.

SELECT SYSTEM
A/T
ENGINE

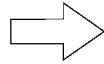

SELECT DIAG MODE
WORK SUPPORT
SELF-DIAG RESULTS
DATA MONITOR
CAN DIAG SUPPORT MNTR
FUNCTION TEST
DTC WORK SUPPORT

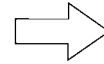

SELF DIAG RESULTS
DTC RESULTS
T/C CLUTCH SOL/V [P0740]

2. Turn CONSULT-II "ON", and touch "A/T".

3. Touch "SELF DIAG-RESULTS".

4. Touch "ERASE". (The DTC in the TCM will be erased.)

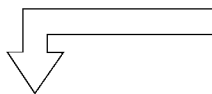

Touch "BACK".

Touch "BACK".

SELECT SYSTEM
A/T
ENGINE

SELECT DIAG MODE
WORK SUPPORT
SELF-DIAG RESULTS
DATA MONITOR
DATA MONITOR(SPEC)
CAN DIAG SUPPORT MNTR
ACTIVE TEST

SELF DIAG RESULTS	
DTC RESULTS	TIME
TCC SOLENOID/CIRC [P0740]	0

5. Touch "ENGINE".

6. Touch "SELF DIAG-RESULTS".

7. Touch "ERASE". (The DTC in the ECM will be erased.)

SCIA5586E

HOW TO ERASE DTC (WITH GST)

1. If the ignition switch stays ON after repair work, be sure to turn ignition switch OFF once. Wait at least 10 seconds and then turn it ON (engine stopped) again.
2. Perform "OBD-II SELF-DIAGNOSTIC PROCEDURE (No Tools)". Refer to [AT-50, "OBD-II SELF-DIAGNOSTIC PROCEDURE \(NO TOOLS\)"](#). (The engine warm-up step can be skipped when performing the diagnosis only to erase the DTC.)
3. Select Mode 4 with Generic Scan Tool (GST). For details, refer to [EC-67, "How to Erase DTC \(With GST\)"](#) (with QR25DE), or [EC-692, "How to Erase DTC \(With GST\)"](#) (with VQ35DE).

HOW TO ERASE DTC (NO TOOLS)

1. If the ignition switch stays ON after repair work, be sure to turn ignition switch OFF once. Wait at least 10 seconds and then turn it ON (engine stopped) again.
2. Perform "TCM SELF-DIAGNOSTIC PROCEDURE (NO TOOLS)". Refer to [AT-51, "TCM SELF-DIAGNOSTIC PROCEDURE \(NO TOOLS\)"](#). (The engine warm-up step can be skipped when performing the diagnosis only to erase the DTC.)

ON BOARD DIAGNOSTIC SYSTEM DESCRIPTION

Malfunction Indicator Lamp (MIL)

ECS006AH

1. The malfunction indicator lamp will light up when the ignition switch is turned ON without the engine running. This is for checking the lamp.
 - If the malfunction indicator lamp does not light up, refer to [DI-22, "WARNING LAMPS"](#).
[Or see [EC-68, "Malfunction Indicator Lamp \(MIL\)"](#) (with QR25DE), or [EC-693, "Malfunction Indicator Lamp \(MIL\)"](#) (with VQ35DE).]
2. When the engine is started, the malfunction indicator lamp should go off.
If the lamp remains on, the on board diagnostic system has detected an emission-related (OBD-II) malfunction. For details, refer to [EC-54, "Emission-related Diagnostic Information"](#) (with QR25DE), or [EC-678, "Emission-related Diagnostic Information"](#) (with VQ35DE).

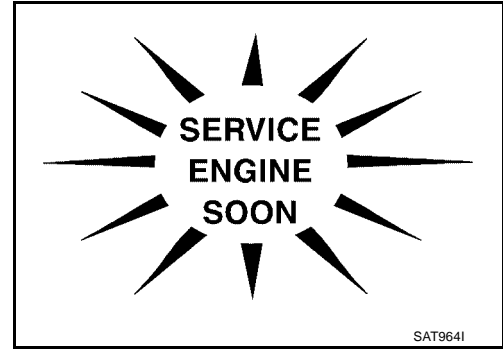

CONSULT-II

ECS006AI

After performing "SELF-DIAGNOSTIC PROCEDURE (WITH CONSULT-II)" ([AT-41, "SELF-DIAGNOSTIC PROCEDURE \(WITH CONSULT-II\)"](#)), place check marks for results on the "Diagnostic Worksheet", [AT-56, "DIAGNOSTIC WORKSHEET"](#). Reference pages are provide following the items.

NOTICE:

1. The CONSULT-II electrically displays shift timing and lock-up timing (that is, operation timing of each solenoid).
Check for time difference between actual shift timing and the CONSULT-II display. If the difference is noticeable, mechanical parts (except solenoids, sensors, etc.) may be malfunctioning. Check mechanical parts using applicable diagnostic procedures.
2. Shift schedule (which implies gear position) displayed on CONSULT-II and that indicated in Service Manual may differ slightly. This occurs because of the following reasons:
 - Actual shift schedule has more or less tolerance or allowance,
 - Shift schedule indicated in Service Manual refers to the point where shifts start, and
 - Gear position displayed on CONSULT-II indicates the point where shifts are completed.
3. Shift solenoid valve "A" or "B" is displayed on CONSULT-II at the start of shifting. Gear position is displayed upon completion of shifting (which is computed by TCM).
4. Additional CONSULT-II information can be found in the Operation Manual supplied with the CONSULT-II unit.

ON BOARD DIAGNOSTIC SYSTEM DESCRIPTION

FUNCTION

Diagnostic test mode	Function	Reference Page
Work support	This mode enables a technician to adjust some devices faster and more accurately by following the indications on CONSULT-II.	—
Self-diagnostic results	Self-diagnostic results can be read and erased quickly.	AT-41
Data monitor	Input/Output data in the ECM can be read.	AT-43
CAN diagnostic support monitor	The results of transmit/receive diagnosis of CAN communication can be read.	—
Function test	Performed by CONSULT-II instead of a technician to determine whether each system is "OK" or "NG".	—
DTC work support	Select the operating condition to confirm Diagnosis Trouble Codes.	AT-50
TCM ECU part number	TCM ECU part number can be read.	—

Ⓜ SELF-DIAGNOSTIC PROCEDURE (WITH CONSULT-II)

1. Touch on CONSULT-II, touch "START", and touch "ENGINE" for OBD-II detected items or touch "A/T" for TCM self-diagnosis. If A/T is not displayed, check TCM power supply and ground circuit. Refer to [AT-100, "TROUBLE DIAGNOSIS FOR POWER SUPPLY"](#) . If result is NG, refer to [PG-3, "POWER SUPPLY ROUTING CIRCUIT"](#) .

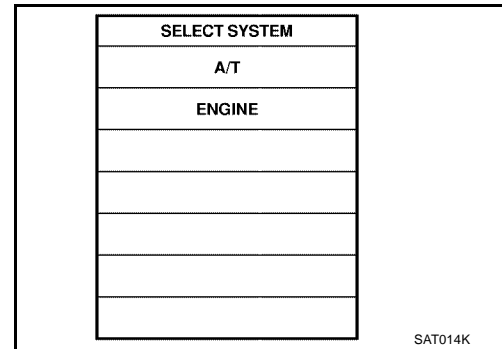

2. Touch "SELF DIAG RESULTS". Display shows malfunction experienced since the last erasing operation. CONSULT-II performs "Real Time Diagnosis". Also, any malfunction detected while in this mode will be displayed at real time.

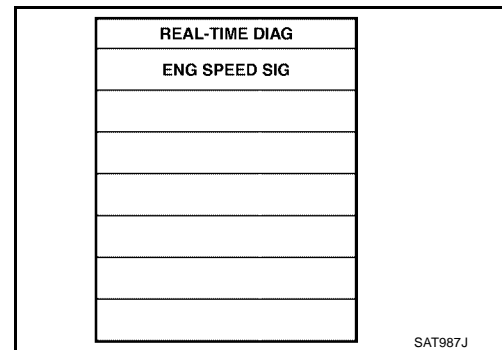

SELF-DIAGNOSTIC RESULT TEST MODE

Detected items (Screen terms for CONSULT-II, "SELF DIAGNOSIS" test mode)		Malfunction is detected when...	TCM self-diagnosis	OBD-II (DTC)
"A/T"	"ENGINE"		Available by A/T check (position) indicator lamp or "A/T" on CONSULT-II	Available by malfunction indicator lamp*2,  "ENGINE" on CONSULT-II or GST
Park/neutral position (PNP) switch circuit	PNP SW/CIRC	● TCM does not receive the correct voltage signal (based on the gear position) from the switch.	—	P0705
—				
Revolution sensor	VEH SPD SEN/ CIR AT	● TCM does not receive the proper voltage signal from the sensor.	X	P0720
VHCL SPEED SEN-A/T				
Vehicle speed sensor (Meter)	—	● TCM does not receive the proper voltage signal from the sensor.	X	—
VHCL SPEED SEN-MTR				

ON BOARD DIAGNOSTIC SYSTEM DESCRIPTION

Detected items (Screen terms for CONSULT-II, "SELF DIAGNOSIS" test mode)		Malfunction is detected when...	TCM self-diagnosis	OBD-II (DTC)
"A/T"	"ENGINE"		Available by A/T check (position) indicator lamp or "A/T" on CONSULT-II	Available by malfunction indicator lamp*2, <small>SERVICE ENGINE SOON</small> "ENGINE" on CONSULT-II or GST
A/T 1st gear function		● A/T cannot be shifted to the 1st gear position even if electrical circuit is good.	—	P0731*1
—	A/T 1ST GR FNCTN			
A/T 2nd gear function		● A/T cannot be shifted to the 2nd gear position even if electrical circuit is good.	—	P0732*1
—	A/T 2ND GR FNCTN			
A/T 3rd gear function		● A/T cannot be shifted to the 3rd gear position even if electrical circuit is good.	—	P0733*1
—	A/T 3RD GR FNCTN			
A/T 4th gear function		● A/T cannot be shifted to the 4th gear position even if electrical circuit is good.	—	P0734*1
—	A/T 4TH GR FNCTN			
A/T TCC S/V function (lock-up)		● A/T cannot perform lock-up even if electrical circuit is good.	—	P0744*1
—	A/T TCC S/V FNCTN			
Shift solenoid valve A		● TCM detects an improper voltage drop when it tries to operate the solenoid valve.	X	P0750
SHIFT SOLENOID/V A	SFT SOL A/CIRC			
Shift solenoid valve B		● TCM detects an improper voltage drop when it tries to operate the solenoid valve.	X	P0755
SHIFT SOLENOID/V B	SFT SOL B/CIRC			
Overrun clutch solenoid valve		● TCM detects an improper voltage drop when it tries to operate the solenoid valve.	X	P1760
OVERRUN CLUTCH S/V	O/R CLUCH SOL/CIRC			
T/C clutch solenoid valve		● TCM detects an improper voltage drop when it tries to operate the solenoid valve.	X	P0740
T/C CLUTCH SOL/V	TCC SOLENOID/CIRC			
Line pressure solenoid valve		● TCM detects an improper voltage drop when it tries to operate the solenoid valve.	X	P0745
LINE PRESSURE S/V	L/PRESS SOL/CIRC			
Throttle position sensor [accelerator pedal position (APP) sensor]		● TCM receives an excessively low or high voltage from this sensor	X	P1705
THROTTLE POSI SEN TP/SEN/CIRC A/T				
Engine speed signal		● TCM does not receive the proper voltage signal from the ECM.	X	P0725
ENGINE SPEED SIG				
A/T fluid temperature sensor		● TCM receives an excessively low or high voltage from the sensor.	X	P0710
BATT/FLUID TEMP SEN	ATF TEMP SEN/CIRC			
Engine control		● The ECM-A/T communication line is open or shorted.	X	U1000
A/T COMM LINE	—			
Turbine revolution sensor		● TCM does not receive proper voltage signal from sensor	X	—
TURBINE REV				

ON BOARD DIAGNOSTIC SYSTEM DESCRIPTION

Detected items (Screen terms for CONSULT-II, "SELF DIAGNOSIS" test mode)		Malfunction is detected when...	TCM self-diagnosis	OBD-II (DTC)
			Available by A/T check (position) indicator lamp or "A/T" on CONSULT-II	Available by malfunction indicator lamp*2, <small>(SERVICE ENGINE SOON)</small> "ENGINE" on CONSULT-II or GST
"A/T"	"ENGINE"			
TCM (RAM)		● TCM memory (RAM) is malfunctioning	—	—
CONTROL UNIT (RAM)	—			
TCM (ROM)		● TCM memory (ROM) is malfunctioning	—	—
CONTROL UNIT (ROM)	—			
TCM (EEP ROM)		● TCM memory (EEP ROM) is malfunctioning.	—	—
CONT UNIT(EEP ROM)	—			
Initial start		● This is not a malfunction message (Whenever shutting off a power supply to the TCM, this message appears on the screen.)	X	—
INITIAL START	—			
No failure (NO SELF DIAGNOSTIC FAILURE INDICATED FURTHER TESTING MAY BE REQUIRED**)		● No failure has been detected.	X	X

X: Applicable
 -: Not applicable

*1: These malfunctions cannot be displayed by MIL (SERVICE ENGINE SOON) if another malfunction is assigned to MIL.

*2: Refer to [EC-68, "Malfunction Indicator Lamp \(MIL\)"](#) (with QR25DE), or [EC-693, "Malfunction Indicator Lamp \(MIL\)"](#) (with VQ35DE).

DATA MONITOR MODE (A/T)

Item	Display	Monitor item			Description	Remarks
		TCM Input signals	Main signals	Selection from menu		
Vehicle speed sensor 1 (A/T) (Revolution sensor)	VHCL/SE-A/T [km/h] or [mph]	X	—	▼	● Vehicle speed computed from signal of revolution sensor is displayed.	● When racing engine in N or P with vehicle stationary, CONSULT-II data may not indicate 0 km/h (0 mph).
Vehicle speed sensor 2 (Meter)	VHCL/SE-MTR [km/h] or [mph]	X	—	▼	● Vehicle speed computed from signal of vehicle speed sensor is displayed.	● Vehicle speed display may not be accurate under approx. 10 km/h (6 mph). It may not indicate 0 km/h (0 mph) when vehicle is stationary.
Throttle position sensor [accelerator pedal position (APP) sensor]	THRTL POS SEN [V]	X	—	▼	● Throttle position sensor signal voltage is displayed	
A/T fluid temperature sensor	FLUID TEMP SE [V]	X	—	▼	● A/T fluid temperature sensor signal voltage is displayed. ● Signal voltage lowers as fluid temperature rises.	

ON BOARD DIAGNOSTIC SYSTEM DESCRIPTION

Item	Display	Monitor item			Description	Remarks
		TCM Input signals	Main signals	Selection from menu		
Battery voltage	BATTERY VOLT [V]	X	—	▼	<ul style="list-style-type: none"> ● Source voltage of TCM is displayed. 	
Engine speed	ENGINE SPEED [rpm]	X	X	▼	<ul style="list-style-type: none"> ● Engine speed, computed from engine speed signal, is displayed. 	<ul style="list-style-type: none"> ● Engine speed display may not be accurate under approx. 800 rpm. It may not indicate 0 rpm even when engine is not running.
Turbine revolution sensor	TURBINE REV	X	—	▼	<ul style="list-style-type: none"> ● Checks changing speed then performs oil pressure control and torque down control 	
Overdrive control switch	OVERDRIVE SW [ON/OFF]	X	—	▼	<ul style="list-style-type: none"> ● ON/OFF state computed from signal of 3 position switch is displayed. 	
PN position (PNP) switch	PN POSI SW [ON/OFF]	X	—	▼	<ul style="list-style-type: none"> ● ON/OFF state computed from signal of PN position SW is displayed. 	
R position switch	R POSITION SW [ON/OFF]	X	—	▼	<ul style="list-style-type: none"> ● ON/OFF state computed from signal of R position SW is displayed. 	
D position switch	D POSITION SW [ON/OFF]	X	—	▼	<ul style="list-style-type: none"> ● ON/OFF state computed from signal of D position SW is displayed. 	
2 position switch	2 POSITION SW [ON/OFF]	X	—	▼	<ul style="list-style-type: none"> ● ON/OFF status, computed from signal of 2 position SW, is displayed. 	
1 position switch	1 POSITION SW [ON/OFF]	X	—	▼	<ul style="list-style-type: none"> ● ON/OFF status, computed from signal of 1 position SW, is displayed. 	
ASCD cruise signal	ASCD-CRUISE [ON/OFF]	X	—	▼	<ul style="list-style-type: none"> ● Status of ASCD cruise signal is displayed. ON ... Cruising state OFF ... Normal running state 	
ASCD OD cut signal	ASCD-OD CUT [ON/OFF]	X	—	▼	<ul style="list-style-type: none"> ● Status of ASCD OD release signal is displayed. ON ... OD released OFF ... OD not released 	

ON BOARD DIAGNOSTIC SYSTEM DESCRIPTION

Item	Display	Monitor item			Description	Remarks
		TCM Input signals	Main signals	Selection from menu		
Kickdown switch	KICKDOWN SW [ON/OFF]	X	—	▼	<ul style="list-style-type: none"> ON/OFF status, computed from signal of kickdown SW, is displayed. 	<ul style="list-style-type: none"> This is displayed even when no kick-down switch is equipped.
Stop lamp switch	BRAKE SW [ON/OFF]	X	—	—	<ul style="list-style-type: none"> ON/OFF status is displayed. ON ... Brake pedal is depressed. OFF ... Brake pedal is released. 	
Selector lever position	SLCT LVR POSI	—	X	▼	<ul style="list-style-type: none"> Selector lever position data, used for computation by TCM, is displayed. 	<ul style="list-style-type: none"> A specific value used for control is displayed if fail-safe is activated due to error.
Vehicle speed	VEHICLE SPEED [km/h] or [mph]	—	X	▼	<ul style="list-style-type: none"> Vehicle speed data, used for computation by TCM, is displayed. 	
Throttle position [Accelerator pedal position (APP) sensor]	THROTTLE POSI [8]	—	X	—	<ul style="list-style-type: none"> Throttle position data, used for computation by TCM, is displayed. 	<ul style="list-style-type: none"> A specific value used for control is displayed if fail-safe is activated due to error.
Gear position	GEAR	—	X	▼	<ul style="list-style-type: none"> Gear position data used for computation by TCM, is displayed. 	
Line pressure duty	LINE PRES DTY [%]	—	X	—	<ul style="list-style-type: none"> Control value of line pressure solenoid valve, computed by TCM from each input signal, is displayed. 	
Torque converter clutch solenoid valve duty	TCC S/V DUTY [%]	—	X	—	<ul style="list-style-type: none"> Control value of torque converter clutch solenoid valve, computed by TCM from each input signal, is displayed. 	
Shift solenoid valve A	SHIFT S/V A [ON/OFF]	—	X	—	<ul style="list-style-type: none"> Control value of shift solenoid valve A, computed by TCM from each input signal, is displayed. 	<ul style="list-style-type: none"> Control value of solenoid is displayed even if solenoid circuit is disconnected. The OFF signal is displayed if solenoid circuit is shorted.
Shift solenoid valve B	SHIFT S/V B [ON/OFF]	—	X	—	<ul style="list-style-type: none"> Control value of shift solenoid valve B, computed by TCM from each input signal, is displayed. 	
Overrun clutch solenoid valve	OVERRUN/C S/V [ON/OFF]	—	X	▼	<ul style="list-style-type: none"> Control value of overrun clutch solenoid valve computed by TCM from each input signal is displayed. 	

A
B
AT
D
E
F
G
H
I
J
K
L
M

ON BOARD DIAGNOSTIC SYSTEM DESCRIPTION

Item	Display	Monitor item			Description	Remarks
		TCM Input signals	Main signals	Selection from menu		
Self-diagnosis display lamp [A/T check (position) indicator lamp]	SELF-D DP LMP [ON/OFF]	—	X	▼	<ul style="list-style-type: none"> Control status of A/T check (position) indicator lamp is displayed. 	
Torque converter slip ratio	TC SLIP RATIO [0.000]	—	—	▼	<ul style="list-style-type: none"> Ratio of engine revolution to input shaft revolution of torque converter. 	
Torque converter slip speed	TC SLIP SPEED [rpm]	—	—	▼	<ul style="list-style-type: none"> Difference in revolution between input shaft revolution and torque converter input shaft revolution. 	<ul style="list-style-type: none"> Display does not indicate engine is stopped even if 0 rpm — this is not a malfunction.
Voltage [V]		—	—	▼	<ul style="list-style-type: none"> Value measured by voltage probe is displayed. 	
Frequency [Hz]		—	—	▼	<ul style="list-style-type: none"> Value measured by pulse probe is displayed. If measurement is impossible, "#" sign is displayed. "#" sign is also displayed at the final data value until the measurement result is obtained. 	
DUTY-HI		—	—	▼	<ul style="list-style-type: none"> Duty cycle value for measurement probe is displayed. Measured pulse width of measurement probe is displayed. 	
DUTY-LOW		—	—	▼		
PLS WIDTH-HI		—	—	▼		
PLS WIDTH-LOW		—	—	▼		

- X: Applicable
 —: Not applicable
 ▼: Option

DTC WORK SUPPORT MODE WITH CONSULT-II

CONSULT-II Setting Procedure

- Turn ignition switch OFF.
- Connect CONSULT-II to Data link connector, which is located in left side dash panel.

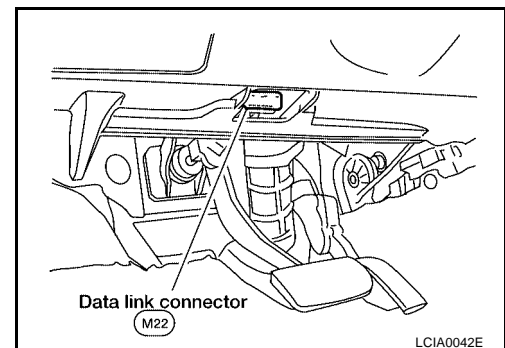

ON BOARD DIAGNOSTIC SYSTEM DESCRIPTION

3. Turn ignition switch ON.
4. Touch "START (NISSAN BASED VHCL)".

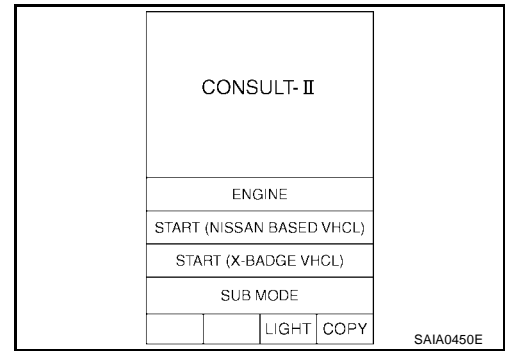

A
B
AT

5. Touch "A/T".

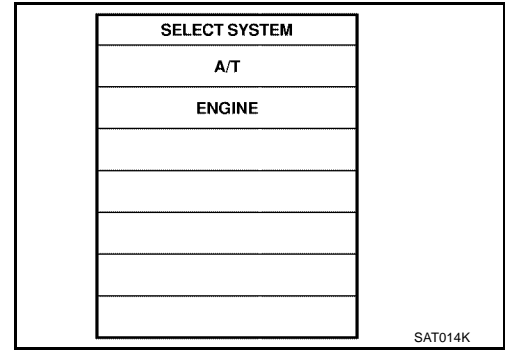

D
E
F
G

6. Touch "DTC WORK SUPPORT".

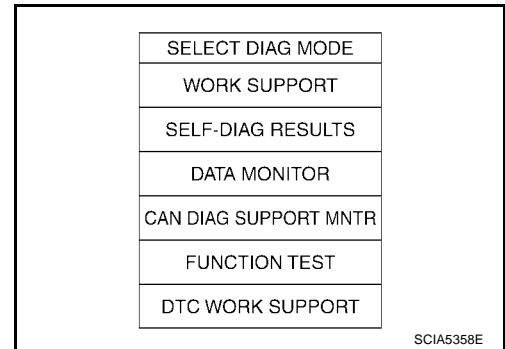

H
I
J
K

7. Touch select item menu (1ST, 2ND, etc.).

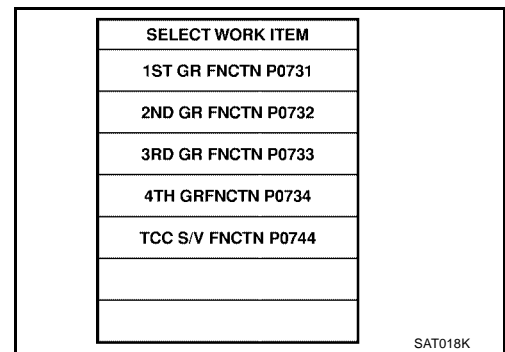

L
M

ON BOARD DIAGNOSTIC SYSTEM DESCRIPTION

8. Touch "START".

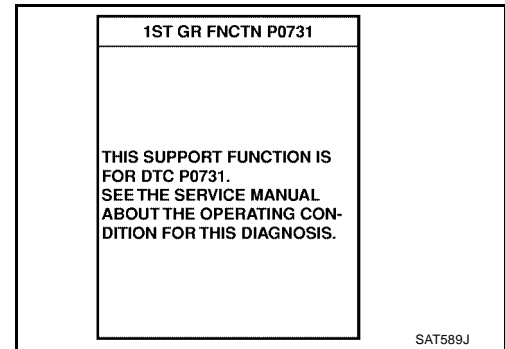

9. Perform driving test according to "DTC CONFIRMATION PROCEDURE" in "TROUBLE DIAGNOSIS FOR DTC".

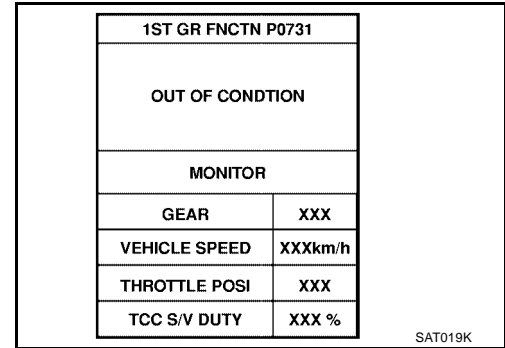

- When testing conditions are satisfied, CONSULT-II screen changes from "OUT OF CONDITION" to "TESTING".

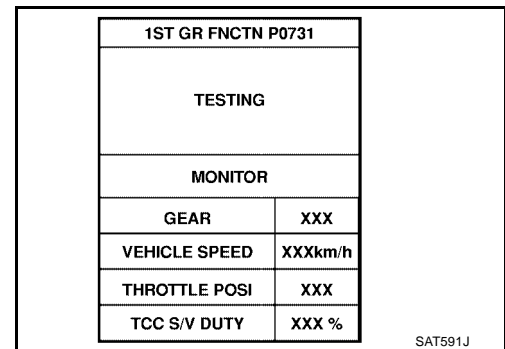

10. Stop vehicle. If "NG" appears on the screen, malfunction may exist. Go to "DIAGNOSTIC PROCEDURE".

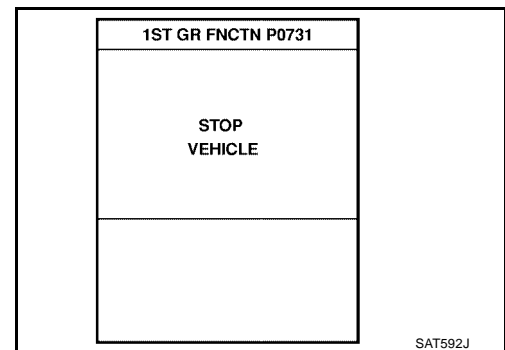

ON BOARD DIAGNOSTIC SYSTEM DESCRIPTION

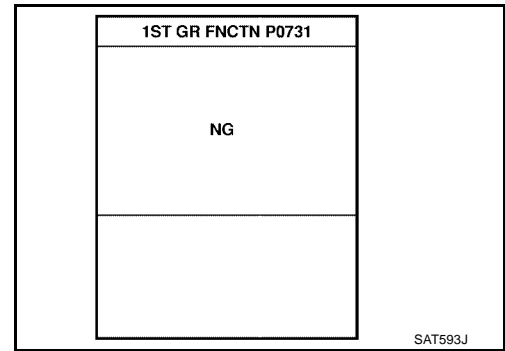

A
B
AT

11. Perform test drive to check gear shift feeling in accordance with instructions displayed.

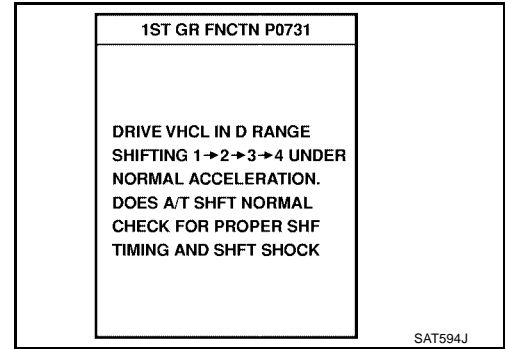

D
E
F
G

12. Touch "YES" or "NO".

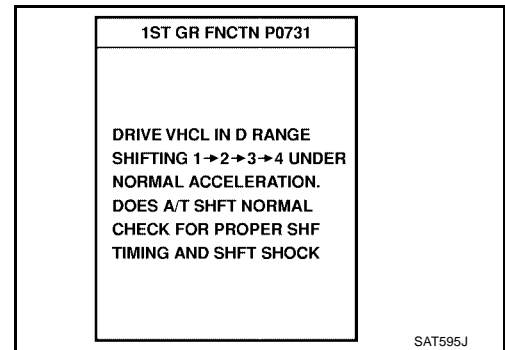

H
I
J
K

13. CONSULT-II procedure ended.

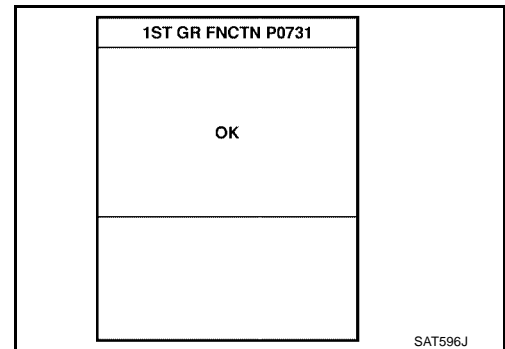

L
M

ON BOARD DIAGNOSTIC SYSTEM DESCRIPTION

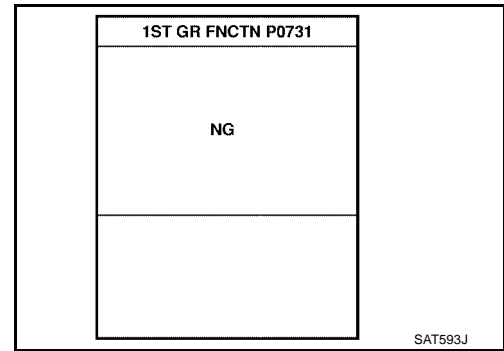

If “NG” appears on the screen, a malfunction may exist. Go to “DIAGNOSTIC PROCEDURE”.

DTC WORK SUPPORT MODE

DTC work support item	Description	Check item
1ST GR FNCTN P0731	<p>Following items for “A/T 1st gear function (P0731)” can be confirmed.</p> <ul style="list-style-type: none"> ● Self-diagnosis status (whether the diagnosis is being conducted or not) ● Self-diagnosis result (OK or NG) 	<ul style="list-style-type: none"> ● Shift solenoid valve A ● Shift solenoid valve B ● Each clutch ● Hydraulic control circuit
2ND GR FNCTN P0732	<p>Following items for “A/T 2nd gear function (P0732)” can be confirmed.</p> <ul style="list-style-type: none"> ● Self-diagnosis status (whether the diagnosis is being conducted or not) ● Self-diagnosis result (OK or NG) 	<ul style="list-style-type: none"> ● Shift solenoid valve B ● Each clutch ● Hydraulic control circuit
3RD GR FNCTN P0733	<p>Following items for “A/T 3rd gear function (P0733)” can be confirmed.</p> <ul style="list-style-type: none"> ● Self-diagnosis status (whether the diagnosis is being conducted or not) ● Self-diagnosis result (OK or NG) 	<ul style="list-style-type: none"> ● Shift solenoid valve A ● Each clutch ● Hydraulic control circuit
4TH GR FNCTN P0734	<p>Following items for “A/T 4th gear function (P0734)” can be confirmed.</p> <ul style="list-style-type: none"> ● Self-diagnosis status (whether the diagnosis is being conducted or not) ● Self-diagnosis result (OK or NG) 	<ul style="list-style-type: none"> ● Shift solenoid valve A ● Shift solenoid valve B ● Overrun clutch solenoid valve ● Line pressure solenoid valve ● Each clutch ● Hydraulic control circuit
TCC S/V FNCTN P0744	<p>Following items for “A/T TCC S/V function (lock-up) (P0744)” can be confirmed.</p> <ul style="list-style-type: none"> ● Self-diagnosis status (whether the diagnosis is being conducted or not) ● Self-diagnosis result (OK or NG) 	<ul style="list-style-type: none"> ● Torque converter clutch solenoid valve ● Each clutch ● Hydraulic control circuit

Diagnostic Procedure Without CONSULT-II

ECS006AJ

OBD-II SELF-DIAGNOSTIC PROCEDURE (WITH GST)

Refer to [EC-118, "Generic Scan Tool \(GST\) Function"](#) (with QR25DE), or [EC-749, "Generic Scan Tool \(GST\) Function"](#) (with VQ35DE).

OBD-II SELF-DIAGNOSTIC PROCEDURE (NO TOOLS)

Refer to [EC-68, "Malfunction Indicator Lamp \(MIL\)"](#) (with QR25DE), or [EC-693, "Malfunction Indicator Lamp \(MIL\)"](#) (with VQ35DE).

ON BOARD DIAGNOSTIC SYSTEM DESCRIPTION



TCM SELF-DIAGNOSTIC PROCEDURE (NO TOOLS)

1. CHECK A/T CHECK (POSITION) INDICATOR LAMP

1. Move selector lever to P position.
Start engine and warm it up to normal engine operating temperature.
2. Turn ignition switch to OFF position.
3. Wait 5 seconds.
4. Turn ignition switch to ON position.
(Do not start engine.)

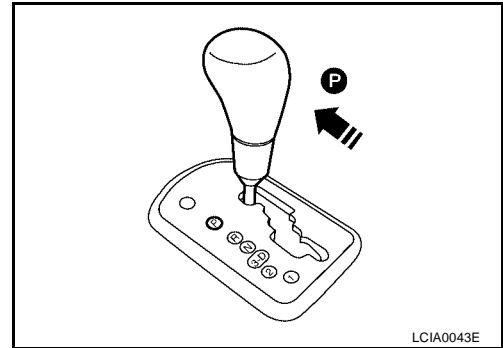

5. Does A/T check (position) indicator lamp come on for about 2 seconds?

Yes or No

Yes >> GO TO 2.

No >> Stop procedure. Perform [AT-213, "1. A/T Check \(Position\) Indicator Lamp Does Not Come On"](#) before proceeding.

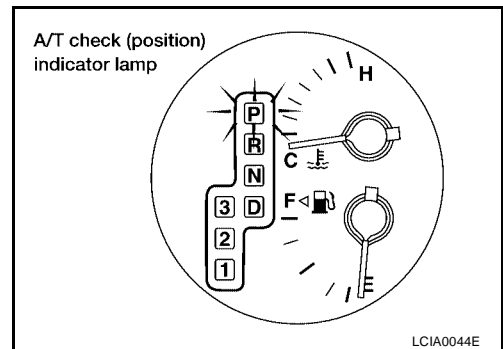

2. JUDGEMENT PROCEDURE STEP 1

1. Turn ignition switch to OFF position.
2. Turn ignition switch to ON position.
(Do not start engine.)
3. Depress the brake pedal, then move gear selector lever from P to D position.
4. Wait 3 seconds.

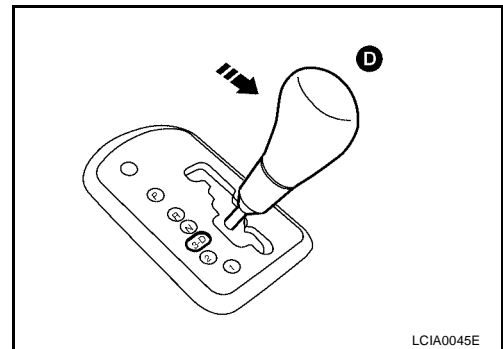

5. Move selector lever to 2 position.
6. Release brake pedal.

>> GO TO 3.

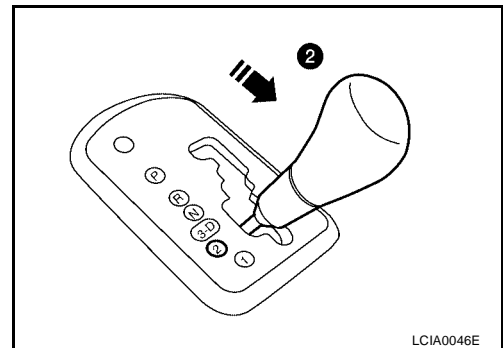

A
B
AT
D
E
F
G
H
I
J
K
L
M

ON BOARD DIAGNOSTIC SYSTEM DESCRIPTION

3. JUDGEMENT PROCEDURE STEP 2

1. Move selector lever to 1 position.
2. Depress brake pedal.
3. Depress accelerator pedal fully and release it.
4. The A/T check (position) indicator lamp will begin to flash.

>> GO TO 4.

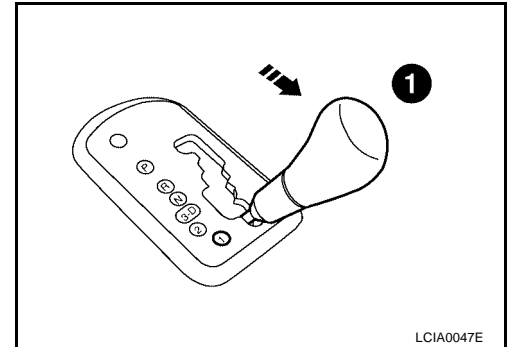

4. CHECK SELF-DIAGNOSTIC CODE

Check A/T check (position) indicator lamp.
Refer to [AT-52. "JUDGEMENT OF SELF-DIAGNOSIS CODE"](#).

>> DIAGNOSIS END

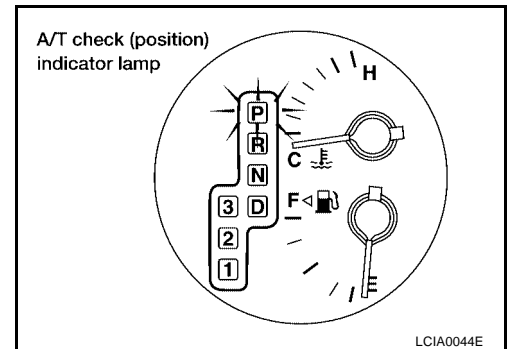

JUDGEMENT OF SELF-DIAGNOSIS CODE

A/T check (position) indicator lamp:

All judgement flickers are the same.

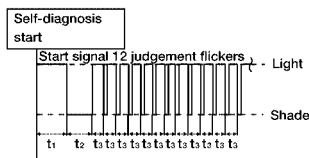

All circuits that can be confirmed by self-diagnosis are OK.

1st judgement flicker is longer than others.



Revolution sensor circuit is short-circuited or disconnected.
⇒ Go to [AT-115. "DTC P0720 VEHICLE SPEED SENSOR-A/T \(REVOLUTION SENSOR\)"](#).

2nd judgement flicker is longer than others.

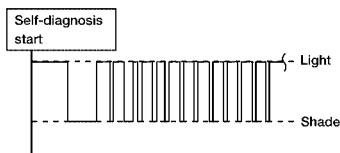

Vehicle speed sensor circuit is short-circuited or disconnected.
⇒ Go to [AT-196. "DTC VEHICLE SPEED SENSOR MTR"](#).

3rd judgement flicker is longer than others.

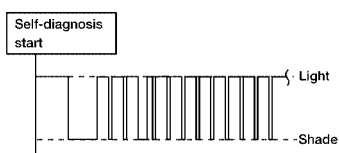

Throttle position sensor circuit is short-circuited or disconnected.
⇒ Go to [AT-175. "DTC P1705 THROTTLE POSITION SENSOR \[ACCELERATOR PEDAL POSITION \(APP\) SENSOR\]"](#).

ON BOARD DIAGNOSTIC SYSTEM DESCRIPTION

A/T check (position) indicator lamp:

4th judgement flicker is longer than others.

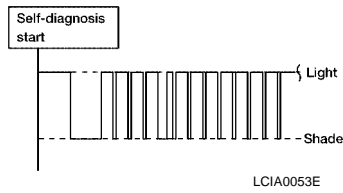

Shift solenoid valve A circuit is short-circuited or disconnected.
⇒ Go to [AT-165, "DTC P0750 SHIFT SOLENOID VALVE A"](#) .

5th judgement flicker is longer than others.

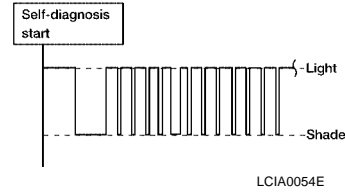

Shift solenoid valve B circuit is short-circuited or disconnected.
⇒ Go to [AT-170, "DTC P0755 SHIFT SOLENOID VALVE B"](#) .

6th judgement flicker is longer than others.

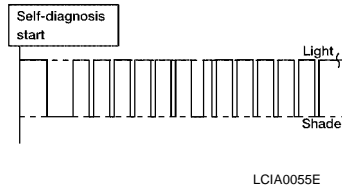

Overrun clutch solenoid valve circuit is short-circuited or disconnected.
⇒ Go to [AT-181, "DTC P1760 OVERRUN CLUTCH SOLENOID VALVE"](#) .

7th judgement flicker is longer than others.

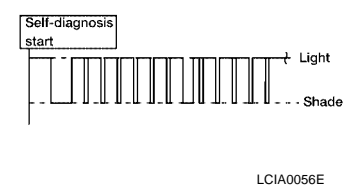

Torque converter clutch solenoid valve circuit is short-circuited or disconnected.
⇒ Go to [AT-146, "DTC P0740 TORQUE CONVERTER CLUTCH SOLENOID VALVE"](#) .

8th judgement flicker is longer than others.

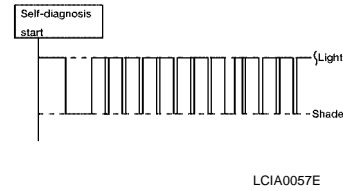

A/T fluid temperature sensor is disconnected or TCM power source circuit is damaged.
⇒ Go to [AT-109, "DTC P0710 A/T FLUID TEMPERATURE SENSOR CIRCUIT"](#) .

9th judgement flicker is longer than others.

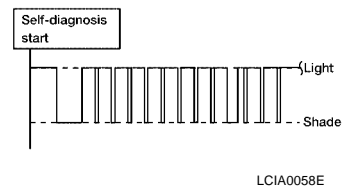

Engine speed signal circuit is short-circuited or disconnected.
⇒ Go to [AT-120, "DTC P0725 ENGINE SPEED SIGNAL"](#) .

10th judgement flicker is longer than others.

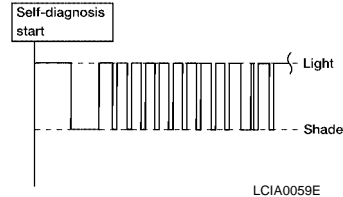

Turbine revolution sensor circuit is short-circuited or disconnected.
⇒ Go to [AT-200, "DTC TURBINE REVOLUTION SENSOR"](#) .

11th judgement flicker is longer than others.

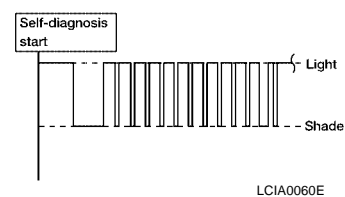

Line pressure solenoid valve circuit is short-circuited or disconnected.
⇒ Go to [AT-159, "DTC P0745 LINE PRESSURE SOLENOID VALVE"](#) .

ON BOARD DIAGNOSTIC SYSTEM DESCRIPTION

A/T check (position) indicator lamp:

12th judgement flicker is longer than others.

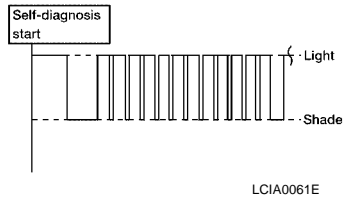

The ECM-A/T communication line is open or shorted.

⇒ Go to [AT-186. "DTC U1000 CAN COMMUNICATION LINE"](#).

Lamp turns off.

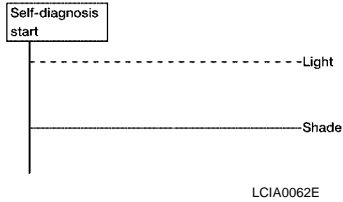

Park/neutral position (PNP) switch, and 3 position switch circuit is disconnected or TCM is damaged.

⇒ Go to [AT-250. "21. TCM Self-diagnosis Does Not Activate \(PNP & 3 Position Switches Circuit Checks\), and Throttle Position Sensor \[Accelerator Pedal Position \(APP\) Sensor\] Circuit Check"](#).

Flickers as shown below.

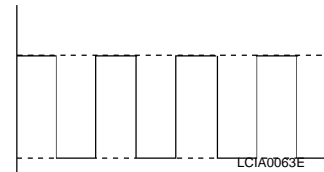

Battery power is low.

Battery has been disconnected for a long time.

Battery is connected conversely.

(When reconnecting TCM connectors. — This is not a problem.)

t1 = 2.5 seconds t2 = 2.0 seconds t3 = 1.0 second t4 = 1.0 second

TROUBLE DIAGNOSIS - INTRODUCTION

PFP:00000

ECS006AK

Introduction

The TCM receives a signal from the vehicle speed sensor, ECM (throttle opening) or park/neutral position (PNP) switch and provides shift control or lock-up control via A/T solenoid valves.

The TCM also communicates with the ECM by means of a signal sent from sensing elements used with the OBD-related parts of the A/T system for malfunction-diagnostic purposes. The TCM is capable of diagnosing malfunctioning parts while the ECM can store malfunctions in its memory.

Input and output signals must always be correct and stable in the operation of the A/T system. The A/T system must be in good operating condition and be free of valve seizure, solenoid valve malfunction, etc.

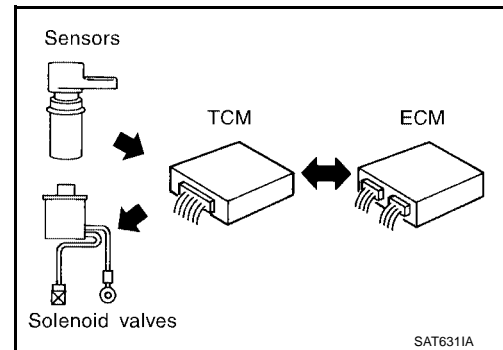

It is much more difficult to diagnose a problem that occurs intermittently rather than continuously. Most intermittent problems are caused by poor electric connections or improper wiring. In this case, careful checking of suspected circuits may help prevent the replacement of good parts.

A visual check only, may not find the cause of the problems. A road test with CONSULT-II (or GST) or a circuit tester connected should be performed. Follow the "Work Flow". Refer to [AT-59, "Work Flow"](#).

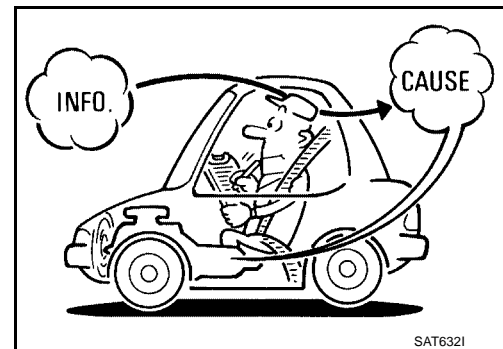

Before undertaking actual checks, take a few minutes to talk with a customer who approaches with a driveability complaint. The customer can supply good information about such problems, especially intermittent ones. Find out what symptoms are present and under what conditions they occur. A "DIAGNOSTIC WORKSHEET" like the example on page [AT-57](#) should be used.

Start your diagnosis by looking for "conventional" problems first. This will help troubleshoot driveability problems on an electronically controlled engine vehicle.

Also check related Service bulletins for information.

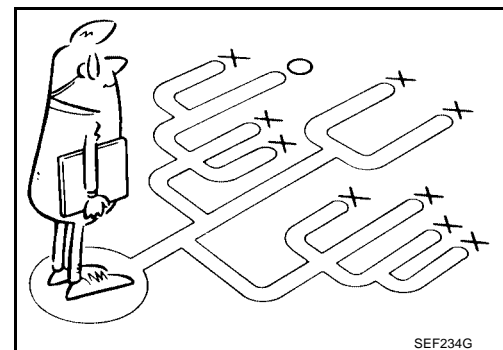

TROUBLE DIAGNOSIS - INTRODUCTION

DIAGNOSTIC WORKSHEET

Information from Customer

KEY POINTS

WHAT Vehicle & A/T model

WHEN Date, Frequencies

WHERE Road conditions

HOW Operating conditions, Symptoms

Customer name MR/MS	Model & Year	VIN
Trans. model	Engine	Mileage
Incident Date	Manuf. Date	In Service Date
Frequency	<input type="checkbox"/> Continuous <input type="checkbox"/> Intermittent (times a day)	
Symptoms	<input type="checkbox"/> Vehicle does not move. (<input type="checkbox"/> Any position <input type="checkbox"/> Particular position)	
	<input type="checkbox"/> No up-shift (<input type="checkbox"/> 1st → 2nd <input type="checkbox"/> 2nd → 3rd <input type="checkbox"/> 3rd → 4th)	
	<input type="checkbox"/> No down-shift (<input type="checkbox"/> 4th → 3rd <input type="checkbox"/> 3rd → 2nd <input type="checkbox"/> 2nd → 1st)	
	<input type="checkbox"/> Lockup malfunction	
	<input type="checkbox"/> Shift point too high or too low.	
	<input type="checkbox"/> Shift shock or slip (<input type="checkbox"/> N → D <input type="checkbox"/> Lockup <input type="checkbox"/> Any drive position)	
	<input type="checkbox"/> Noise or vibration	
	<input type="checkbox"/> No kickdown	
	<input type="checkbox"/> No pattern select	
A/T check (position) indicator lamp	Blinks for about 8 seconds.	
	<input type="checkbox"/> Continuously lit	<input type="checkbox"/> Not lit
Malfunction indicator lamp (MIL)	<input type="checkbox"/> Continuously lit	<input type="checkbox"/> Not lit

TROUBLE DIAGNOSIS - INTRODUCTION

Diagnostic Worksheet

1.	<input type="checkbox"/> Read the Fail-safe and listen to customer complaints.	AT-9	A		
2.	<input type="checkbox"/> CHECK A/T FLUID	AT-61			
	<input type="checkbox"/> Leakage (Follow specified procedure) <input type="checkbox"/> Fluid condition <input type="checkbox"/> Fluid level		B		
3.	<input type="checkbox"/> Perform STALL TEST and PRESSURE TEST.	AT-61 , AT-65	AT		
	<input type="checkbox"/> Stall test — Mark possible damaged components/others.				
	<table border="1" style="width: 100%; border-collapse: collapse;"> <tr> <td style="width: 50%; vertical-align: top;"> <input type="checkbox"/> Torque converter one-way clutch <input type="checkbox"/> Reverse clutch <input type="checkbox"/> Forward clutch <input type="checkbox"/> Overrun clutch <input type="checkbox"/> Forward one-way clutch </td> <td style="width: 50%; vertical-align: top;"> <input type="checkbox"/> Low & reverse brake <input type="checkbox"/> Low one-way clutch <input type="checkbox"/> Engine <input type="checkbox"/> Line pressure is low <input type="checkbox"/> Clutches and brakes except high clutch and brake band are OK </td> </tr> </table>	<input type="checkbox"/> Torque converter one-way clutch <input type="checkbox"/> Reverse clutch <input type="checkbox"/> Forward clutch <input type="checkbox"/> Overrun clutch <input type="checkbox"/> Forward one-way clutch	<input type="checkbox"/> Low & reverse brake <input type="checkbox"/> Low one-way clutch <input type="checkbox"/> Engine <input type="checkbox"/> Line pressure is low <input type="checkbox"/> Clutches and brakes except high clutch and brake band are OK		D
<input type="checkbox"/> Torque converter one-way clutch <input type="checkbox"/> Reverse clutch <input type="checkbox"/> Forward clutch <input type="checkbox"/> Overrun clutch <input type="checkbox"/> Forward one-way clutch	<input type="checkbox"/> Low & reverse brake <input type="checkbox"/> Low one-way clutch <input type="checkbox"/> Engine <input type="checkbox"/> Line pressure is low <input type="checkbox"/> Clutches and brakes except high clutch and brake band are OK				
	<input type="checkbox"/> Pressure test — Suspected parts:		E		
4.	<input type="checkbox"/> Perform all ROAD TEST and mark required procedures.	AT-66			
4-1.	Check before engine is started.	AT-68	F		
1.	<input type="checkbox"/> SELF-DIAGNOSTIC PROCEDURE - Mark detected items.				
	<input type="checkbox"/> Park/neutral position (PNP) switch, AT-103 . <input type="checkbox"/> A/T fluid temperature sensor, AT-109 . <input type="checkbox"/> Vehicle speed sensor-A/T (Revolution sensor), AT-115 . <input type="checkbox"/> Engine speed signal, AT-120 . <input type="checkbox"/> Turbine revolution sensor, AT-200 . <input type="checkbox"/> Torque converter clutch solenoid valve, AT-146 . <input type="checkbox"/> Line pressure solenoid valve, AT-159 . <input type="checkbox"/> Shift solenoid valve A, AT-165 . <input type="checkbox"/> Shift solenoid valve B, AT-170 . <input type="checkbox"/> Throttle position sensor [accelerator pedal position (APP) sensor], AT-175 . <input type="checkbox"/> Overrun clutch solenoid valve, AT-181 . <input type="checkbox"/> Park/neutral position (PNP) & 3 position switches circuit checks, and throttle position sensor [accelerator pedal position (APP) sensor circuit check AT-250 . <input type="checkbox"/> A/T fluid temperature sensor, AT-109 . <input type="checkbox"/> Vehicle speed sensor-MTR, AT-196 . <input type="checkbox"/> CAN communication line, AT-186 . <input type="checkbox"/> Control unit (RAM), Control unit (ROM), AT-205 . <input type="checkbox"/> Control unit (EEP ROM), AT-207 . <input type="checkbox"/> Battery <input type="checkbox"/> Others		G		
			H		
			I		
			J		
			K		
			L		

TROUBLE DIAGNOSIS - INTRODUCTION

4- 2.	<p>Check at idle</p> <ul style="list-style-type: none"> <input type="checkbox"/> 1. A/T Check (Position) Indicator Lamp Does Not Come On, AT-213 . <input type="checkbox"/> 2. Engine Cannot Be Started In P and N Position, AT-215 . <input type="checkbox"/> 3. In P Position, Vehicle Moves Forward or Backward When Pushed, AT-216 . <input type="checkbox"/> 4. In N Position, Vehicle Moves, AT-217 . <input type="checkbox"/> 5. Large Shock. N → R Position, AT-219 . <input type="checkbox"/> 6. Vehicle Does Not Creep Backward In R Position, AT-221 . <input type="checkbox"/> 7. Vehicle Does Not Creep Forward In D, 2 or 1 Position, AT-224 . 	AT-68
4- 3.	<p>Cruise test</p> <p>Part-1</p> <ul style="list-style-type: none"> <input type="checkbox"/> 8. Vehicle Cannot Be Started From D1 , AT-227 . <input type="checkbox"/> 9. A/T Does Not Shift: D1 → D2 or Does Not Kickdown: D4 → D2 , AT-230 . <input type="checkbox"/> 10. A/T Does Not Shift: D2 → D3 , AT-233 . <input type="checkbox"/> 11. A/T Does Not Shift: D3 → D4 , AT-236 . <input type="checkbox"/> 12. A/T Does Not Perform Lock-up, AT-239 . <input type="checkbox"/> 13. A/T Does Not Hold Lock-up Condition, AT-241 . <input type="checkbox"/> 14. Lock-up Is Not Released, AT-243 . <input type="checkbox"/> 15. Engine Speed Does Not Return To Idle (Light Braking D4 → D3) , AT-244 . <p>Part-2</p> <ul style="list-style-type: none"> <input type="checkbox"/> 16. Vehicle Does Not Start From D1 , AT-246 . <input type="checkbox"/> 9. A/T Does Not Shift: D1 → D2 or Does Not Kickdown: D4 → D2 , AT-230 . <input type="checkbox"/> 10. A/T Does Not Shift: D2 → D3 , AT-233 . <input type="checkbox"/> 11. A/T Does Not Shift: D3 → D4 , AT-236 . <p>Part-3</p> <ul style="list-style-type: none"> <input type="checkbox"/> 17. A/T Does Not Shift: D4 → D3 When Gear Selector Lever D → 3, AT-247 . <input type="checkbox"/> 15. Engine Speed Does Not Return To Idle (Engine Brake In D3) , AT-244 . <input type="checkbox"/> 18. A/T Does Not Shift: D3 → 22 , When Selector Lever D → 2 Position, AT-248 . <input type="checkbox"/> 15. Engine Speed Does Not Return To Idle (Engine Brake In 22) , AT-244 . <input type="checkbox"/> 19. A/T Does Not Shift: 22 → 11 , When Selector Lever 2 → 1 Position, AT-249 . <input type="checkbox"/> 20. Vehicle Does Not Decelerate By Engine Brake, AT-250 . <input type="checkbox"/> SELF-DIAGNOSTIC PROCEDURE — Mark detected items. 	AT-70 AT-75
4.	<ul style="list-style-type: none"> <input type="checkbox"/> Park/neutral position (PNP) switch, AT-103 . <input type="checkbox"/> A/T fluid temperature sensor, AT-109 . <input type="checkbox"/> Vehicle speed sensor-A/T (Revolution sensor), AT-115 . <input type="checkbox"/> Engine speed signal, AT-120 . <input type="checkbox"/> Turbine revolution sensor, AT-200 . <input type="checkbox"/> Torque converter clutch solenoid valve, AT-146 . <input type="checkbox"/> Line pressure solenoid valve, AT-159 . <input type="checkbox"/> Shift solenoid valve A, AT-165 . <input type="checkbox"/> Shift solenoid valve B, AT-170 . <input type="checkbox"/> Throttle position sensor [accelerator pedal position (APP) sensor], AT-175 . <input type="checkbox"/> Overrun clutch solenoid valve, AT-181 . <input type="checkbox"/> Park/neutral position (PNP) & 3 position switches circuit checks, and throttle position sensor [accelerator pedal position (APP) sensor] circuit check, AT-250 . <input type="checkbox"/> A/T fluid temperature sensor, AT-109 . <input type="checkbox"/> Vehicle speed sensor-MTR, AT-196 . <input type="checkbox"/> CAN communication line, AT-186 . <input type="checkbox"/> Control unit (RAM), Control unit (ROM), AT-205 . <input type="checkbox"/> Control unit (EEP ROM), AT-207 . <input type="checkbox"/> Battery <input type="checkbox"/> Others 	AT-78 AT-80
5.	<input type="checkbox"/> For self-diagnosis NG items, inspect each component. Repair or replace the damaged parts.	AT-264
6.	<input type="checkbox"/> Perform all ROAD TEST and re-mark required procedures.	AT-66

TROUBLE DIAGNOSIS - INTRODUCTION

7.	<input type="checkbox"/> Perform DTC CONFIRMATION PROCEDURE for following MIL indicating items and check out NG items. Refer to EC-54, "Emission-related Diagnostic Information" (with QR25DE), or EC-678, "Emission-related Diagnostic Information" (with VQ35DE).	EC-54, EC-678
	<input type="checkbox"/> DTC (P0731) A/T 1st gear function, AT-124 . <input type="checkbox"/> DTC (P0732) A/T 2nd gear function, AT-129 . <input type="checkbox"/> DTC (P0733) A/T 3rd gear function, AT-134 . <input type="checkbox"/> DTC (P0734) A/T 4th gear function, AT-139 . <input type="checkbox"/> DTC (P0744) A/T TCC S/V function (lock-up), AT-151 .	
8.	<input type="checkbox"/> Perform the Diagnostic Procedures for all remaining items marked NG. Repair or replace the damaged parts. Refer to the Symptom Chart when you perform the procedures. (The chart also shows some other possible symptoms and the component inspection orders.)	AT-41 AT-50
9.	<input type="checkbox"/> Erase DTC from TCM and ECM memories.	AT-38

Work Flow

ECS006AL

HOW TO PERFORM TROUBLE DIAGNOSES FOR QUICK AND ACCURATE REPAIR

A good understanding of the malfunction conditions can make troubleshooting faster and more accurate. In general, each customer feels differently about a problem. It is important to fully understand the symptoms or conditions for a customer complaint.

Make good use of the two sheets provided, [AT-56, "Information from Customer"](#) and [AT-57, "Diagnostic Worksheet"](#), to perform the best troubleshooting possible.

TROUBLE DIAGNOSIS - INTRODUCTION

WORK FLOW CHART

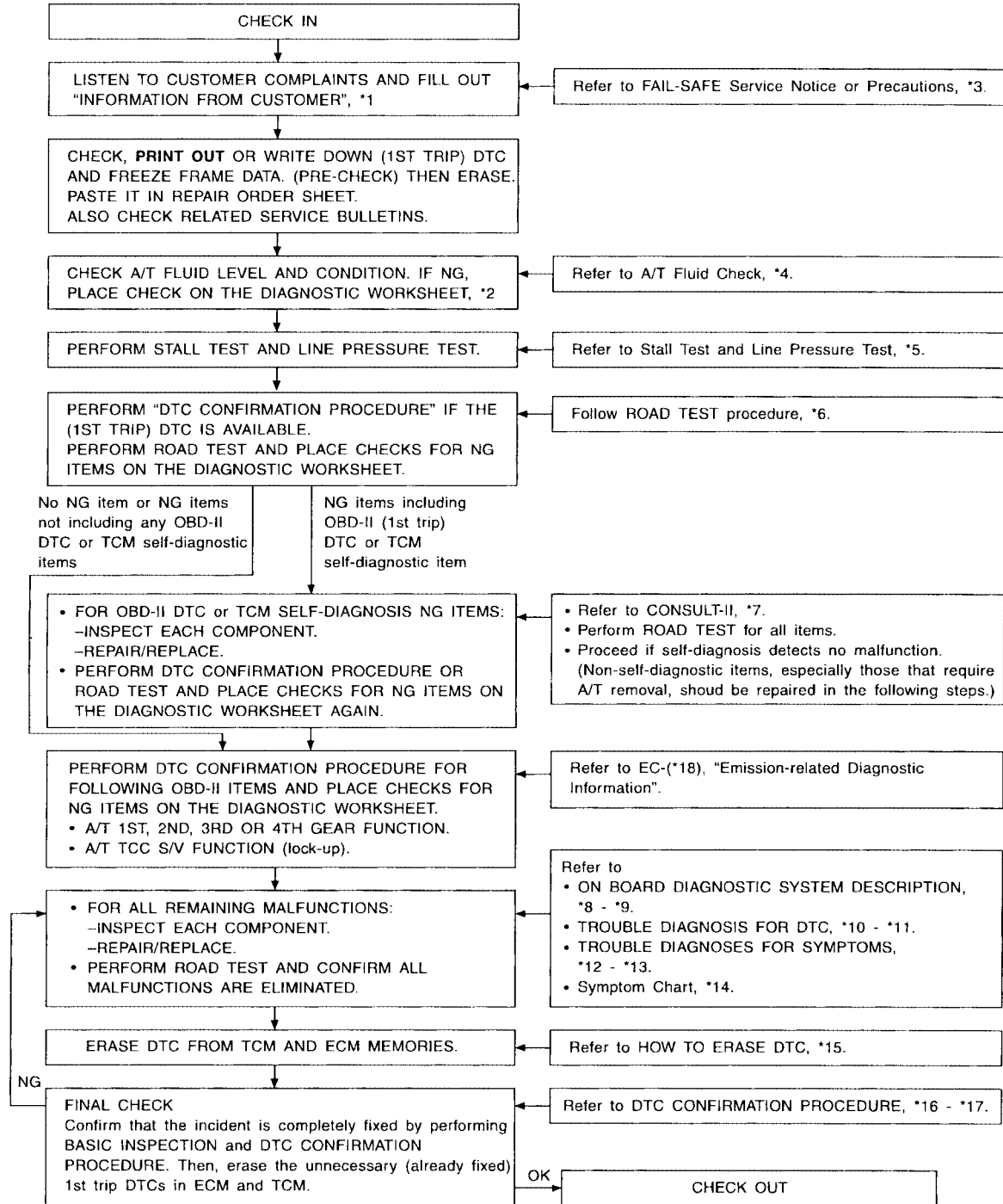

*1: [AT-56](#)

*4: [AT-61](#)

*7: [AT-40](#)

*10: [AT-36](#)

*13: [AT-209](#)

*16: [AT-103](#)

*2: [AT-57](#)

*5: [AT-61](#), [AT-65](#)

*8: [AT-36](#)

*11: [AT-36](#)

*14: [AT-82](#)

*17: [AT-189](#)

*3: [AT-9](#)

*6: [AT-66](#)

*9: [AT-36](#)

*12: [AT-209](#)

*15: [AT-38](#)

*18: [EC-54](#), [EC-678](#)

SAT086J

TROUBLE DIAGNOSIS - BASIC INSPECTION

TROUBLE DIAGNOSIS - BASIC INSPECTION

PF0:0000

A/T Fluid Check

ECS006AM

FLUID LEAKAGE CHECK

1. Clean area suspected of leaking. — for example, mating surface of converter housing and transmission case.
2. Start engine, apply foot brake, place selector lever in D position and wait a few minutes.
3. Stop engine.

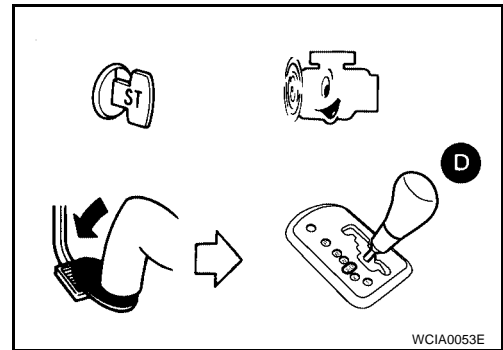

4. Check for fresh leakage.

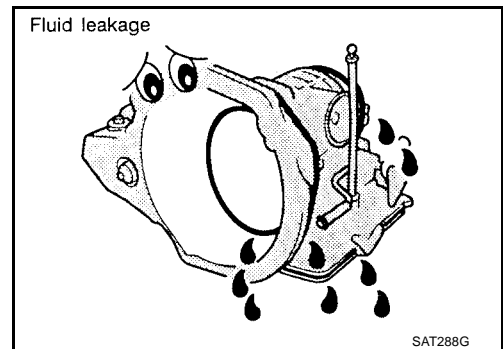

FLUID CONDITION CHECK

Fluid color	Suspected problem
Dark or black with burned odor	Wear of frictional material
Milky pink	Water contamination — Road water entering through filler tube or breather
Varnished fluid, light to dark brown and tacky	Oxidation — Over or under filling, — Overheating

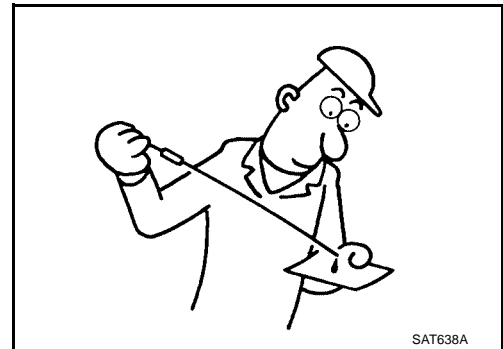

FLUID LEVEL CHECK

Refer to [MA-30, "Checking A/T Fluid"](#) .

Stall Test

STALL TEST PROCEDURE

1. Check A/T fluid and engine oil levels. If necessary, add fluid and oil.
2. Drive vehicle for approximately 10 minutes or until fluid and oil reach operating temperature.

ATF operating temperature :50 - 80°C (122 - 176°F)

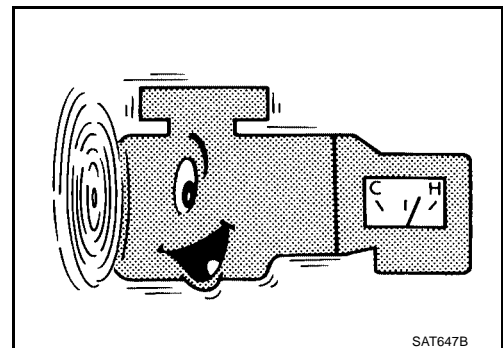

TROUBLE DIAGNOSIS - BASIC INSPECTION

3. Set parking brake and block wheels.
4. Install a tachometer where it can be seen by driver during test.
 - It is good practice to mark the point of specified engine rpm on indicator.

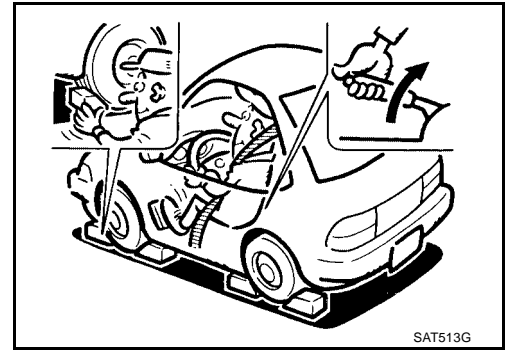

5. Start engine, apply foot brake, and place selector lever in D position.
6. Accelerate to wide open throttle gradually while applying foot brake.
7. Quickly note the engine stall revolution and immediately release throttle.
 - During test, never hold throttle wide open for less than 5 seconds.

Stall revolution

QR25DE : 2,350 - 2,800 rpm

VQ35DE : 2,550 - 3,050 rpm

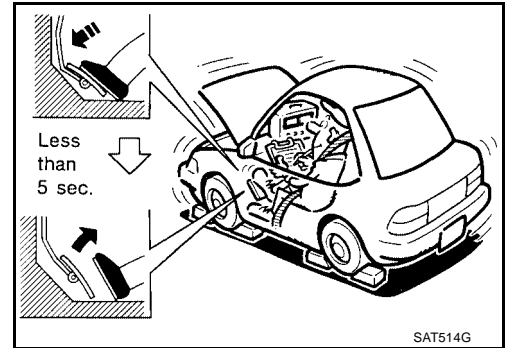

8. Move selector lever to N position.
9. Cool off ATF.
 - Run engine at idle for at least one minute.
10. Repeat steps 5 through 9 with selector lever in 2, 1 and R positions.

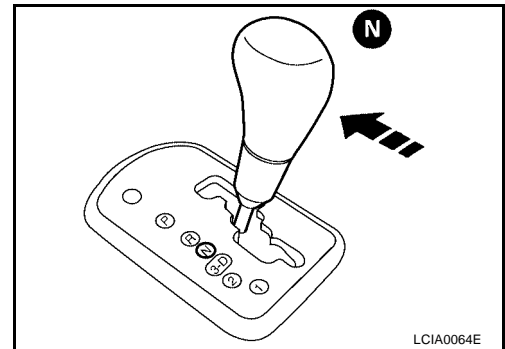

JUDGEMENT OF STALL TEST

The test result and possible damaged components relating to each result are shown in the illustrations on next page.

In order to pinpoint the possible damaged components, refer to [AT-60, "WORK FLOW CHART"](#).

NOTE:

Stall revolution is too high in D, 2 or 1 position:

- Slippage occurs in 1st gear but not in 2nd and 3rd gears. Low one-way clutch slippage
- Slippage occurs in the following gears:
 - 1st through 3rd gears in 3 position and engine brake functions.
 - 1st and 2nd gears in 2 position and engine brake functions with accelerator pedal released (fully closed throttle). Forward clutch or forward one-way clutch slippage

Stall revolution is too high in R position:

- Engine brake does not function in 1 position. Low & reverse brake slippage
- Engine brake functions in 1 position. Reverse clutch slippage

Stall revolution within specifications:

- Vehicle does not achieve speed of more than 80 km/h (50 MPH). One-way clutch seizure in torque converter housing

CAUTION:

Be careful since automatic fluid temperature increases abnormally.

TROUBLE DIAGNOSIS - BASIC INSPECTION

- Slippage occurs in 3rd and 4th gears in D position. High clutch slippage
- Slippage occurs in 2nd and 4th gear in D position. Brake band slippage
- Engine brake does not function in 2nd and 3rd gears in D position, 2nd gear in 2 position, and 1st gear in 1 position.

Stall revolution less than specifications:

A

B

AT

D

E

F

G

H

I

J

K

L

M

TROUBLE DIAGNOSIS - BASIC INSPECTION

- Poor acceleration during starts. One-way clutch seizure in torque converter

Selector lever position	Judgement		
D	H	O	L
2	H	O	L
1	H	O	L
R	O	H	L

O : Stall revolution is normal.
 H : Stall revolution is higher than specified.
 L : Stall revolution is lower than specified.

Damaged components

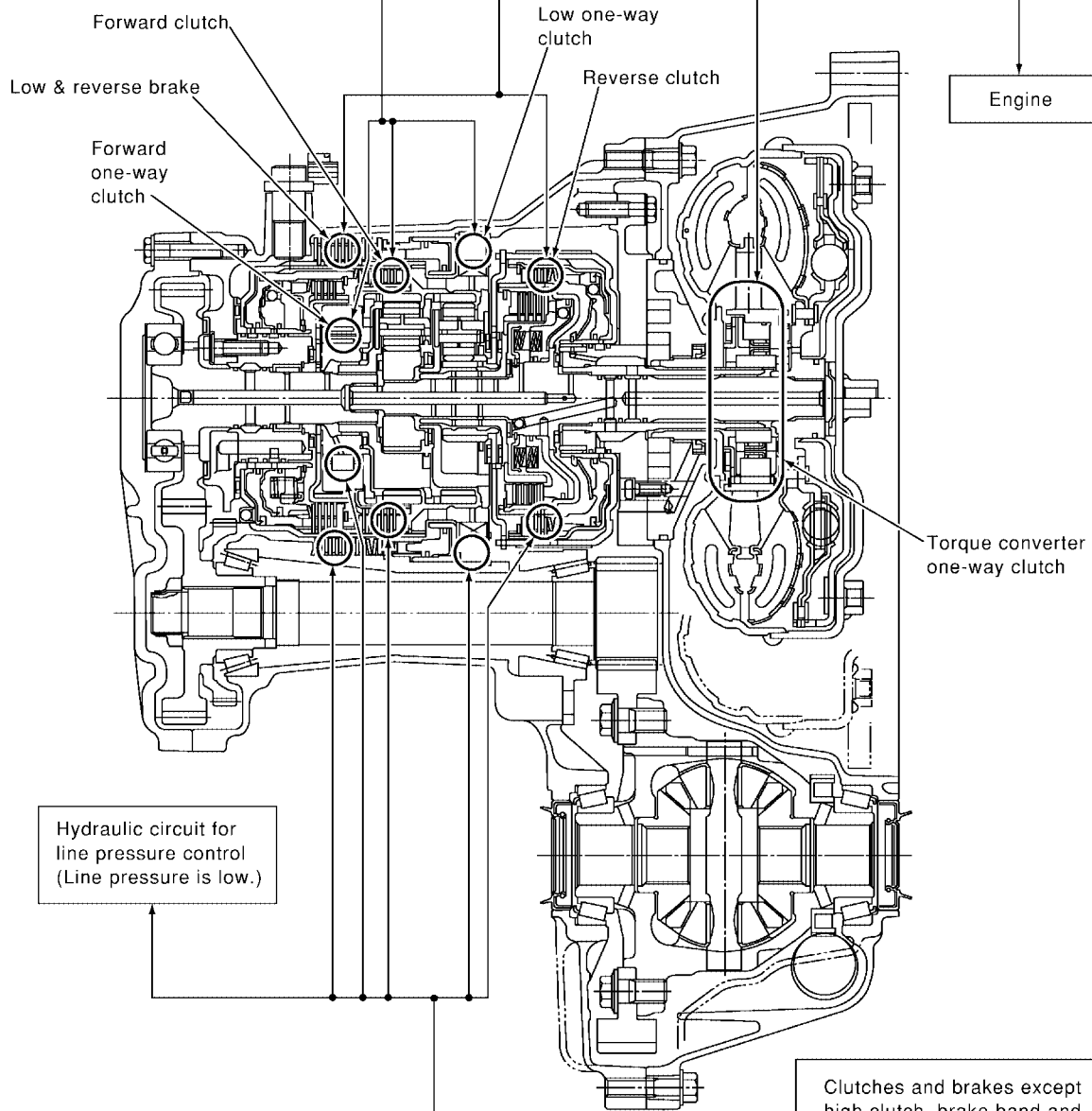

D	H	O
2	H	O
1	H	O
R	H	O
Selector lever position	Judgement	

SAT499K

TROUBLE DIAGNOSIS - BASIC INSPECTION

Line Pressure Test LINE PRESSURE TEST PORTS

ECS006AO

Location of line pressure test ports are shown in the illustration.

- Always replace pressure plugs as they are self-sealing bolts.

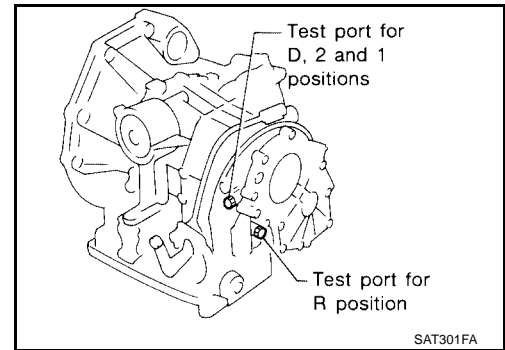

LINE PRESSURE TEST PROCEDURE

1. Check A/T fluid and engine oil levels. If necessary, add fluid and oil.
2. Drive vehicle for approximately 10 minutes or until fluid and oil reach operating temperature.

ATF operating temperature :50 - 80°C (122 - 176°F)

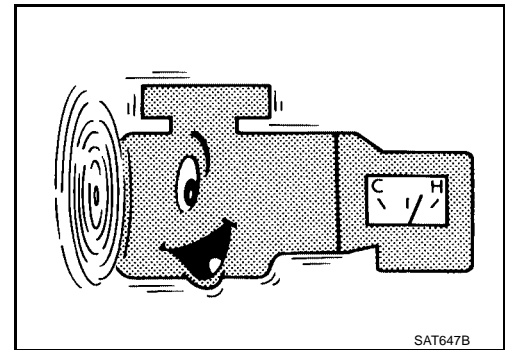

3. Install pressure gauge to corresponding line pressure port.

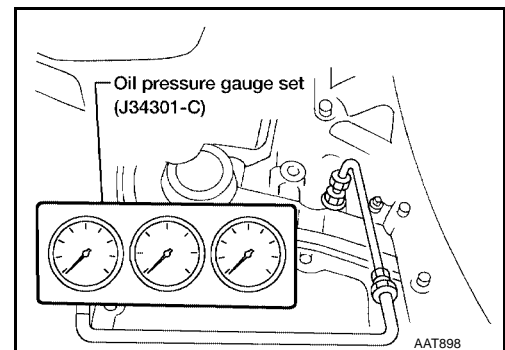

4. Set parking brake and block wheels.
 - Continue to depress brake pedal fully while line pressure test is being performed at stall speed.

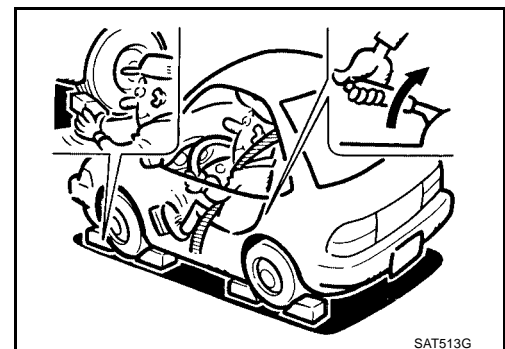

TROUBLE DIAGNOSIS - BASIC INSPECTION

5. Start engine and measure line pressure at idle and stall speed.
- When measuring line pressure at stall speed, follow the stall test procedure.

[AT-65, "Line Pressure Test"](#) : Refer to SDS, [AT-374, "Line Pressure"](#)

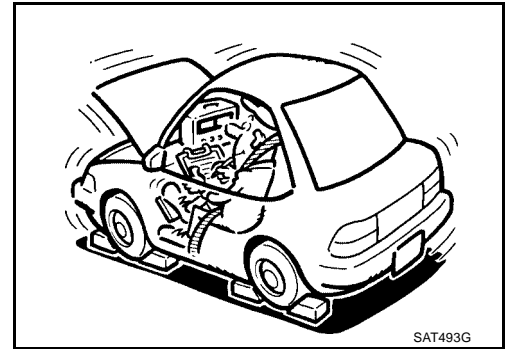

JUDGEMENT OF LINE PRESSURE TEST

Judgement		Suspected parts
At idle	Line pressure is low in all positions.	<ul style="list-style-type: none"> ● Oil pump wear ● Control piston damage ● Pressure regulator valve or plug sticking ● Spring for pressure regulator valve damaged ● Fluid pressure leakage between oil strainer and pressure regulator valve ● Clogged strainer
	Line pressure is low in particular position.	<ul style="list-style-type: none"> ● Fluid pressure leakage between manual valve and particular clutch ● For example, line pressure is: <ul style="list-style-type: none"> – Low in R and 1 positions, but – Normal in D and 2 positions. Therefore, fluid leakage exists at or around low and reverse brake circuit. Refer to AT-19, "CLUTCH AND BAND CHART" .
	Line pressure is high.	<ul style="list-style-type: none"> ● A/T fluid temperature sensor damaged ● Line pressure solenoid valve sticking ● Short circuit of line pressure solenoid valve circuit ● Pressure modifier valve sticking ● Pressure regulator valve or plug sticking ● Open in dropping resistor circuit
At stall speed	Line pressure is low.	<ul style="list-style-type: none"> ● Line pressure solenoid valve sticking ● Short circuit of line pressure solenoid valve circuit ● Pressure regulator valve or plug sticking ● Pressure modifier valve sticking ● Pilot valve sticking

Road Test DESCRIPTION

ECS006AP

- The purpose of the test is to determine overall performance of A/T and analyze causes of problems.
- The road test consists of the following three parts:
 1. Check before engine is started
 2. Check at idle
 3. Cruise test

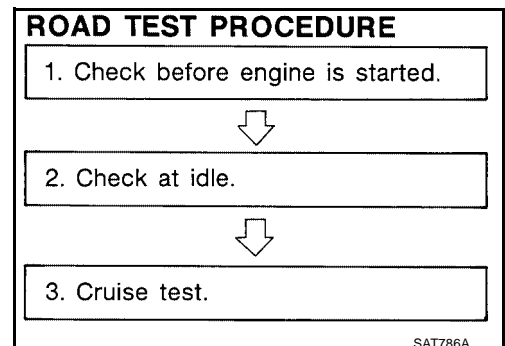

SAT786A

TROUBLE DIAGNOSIS - BASIC INSPECTION

- Before road test, familiarize yourself with all test procedures and items to check.
- Conduct tests on all items until specified symptom is found. Troubleshoot items which check out No Good after road test. Refer to [AT-36, "ON BOARD DIAGNOSTIC SYSTEM DESCRIPTION"](#) , and [AT-209, "TROUBLE DIAGNOSIS FOR SYMPTOMS"](#) .

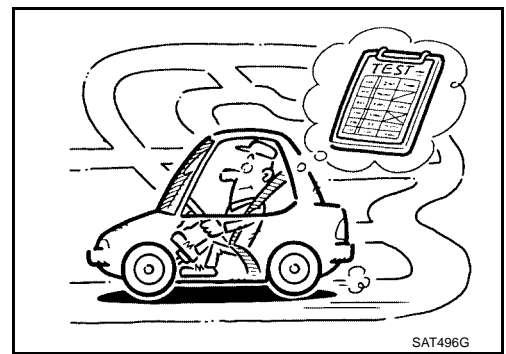

A

B

AT

D

E

F

G

H

I

J

K

L

M

TROUBLE DIAGNOSIS - BASIC INSPECTION

1. CHECK BEFORE ENGINE IS STARTED

1. CHECK A/T CHECK (POSITION) INDICATOR LAMP

1. Park vehicle on flat surface.
2. Move selector lever to P position.
3. Turn ignition switch to OFF position. Wait at least 5 seconds.
4. Turn ignition switch to ON position. (Do not start engine.)
5. Does A/T check (position) indicator lamp come on for about 2 seconds?

Yes or No

- Yes >> GO TO 2.
No >> Stop ROAD TEST. Go to [AT-213, "1. A/T Check \(Position\) Indicator Lamp Does Not Come On"](#).

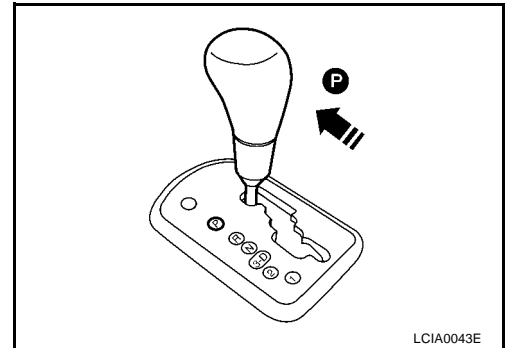

2. CHECK A/T CHECK (POSITION) INDICATOR LAMP

Does A/T check (position) OFF indicator lamp flicker for about 8 seconds?

Yes or No

- Yes >> Perform self-diagnosis and check NG items on the DIAGNOSTIC WORKSHEET, [AT-57](#). Refer to [AT-51, "TCM SELF-DIAGNOSTIC PROCEDURE \(NO TOOLS\)"](#).
- No >> 1. Turn ignition switch to OFF position.
2. Perform self-diagnosis and note NG items. Refer to [AT-51, "TCM SELF-DIAGNOSTIC PROCEDURE \(NO TOOLS\)"](#).
3. Go to [AT-68, "2. CHECK AT IDLE"](#).

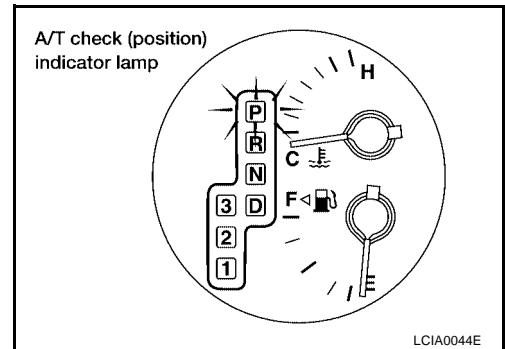

2. CHECK AT IDLE

1. CHECK ENGINE START

1. Park vehicle on flat surface.
2. Move selector lever to P position.
3. Turn ignition switch to OFF position.
4. Turn ignition switch to START position.
5. Is engine started?

Yes or No

- Yes >> GO TO 2.
No >> Mark the box on the DIAGNOSTIC WORKSHEET. Go to [AT-215, "2. Engine Cannot Be Started In P and N Position"](#). Continue ROAD TEST.

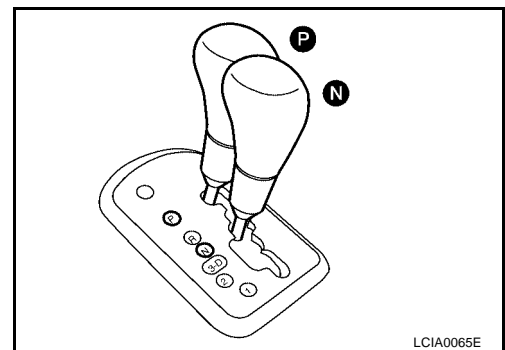

TROUBLE DIAGNOSIS - BASIC INSPECTION

2. CHECK ENGINE START

1. Turn ignition switch to ACC position.
2. Move selector lever to D, 1, 2 or R position.
3. Turn ignition switch to START position.
4. Is engine started?

Yes or No

- Yes >> Mark the box on the DIAGNOSTIC WORKSHEET. Go to [AT-215, "2. Engine Cannot Be Started In P and N Position"](#). Continue ROAD TEST.
- No >> GO TO 3.

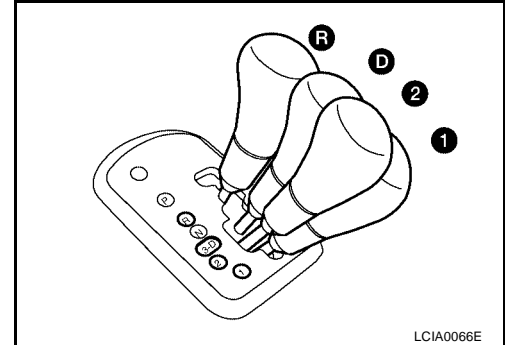

3. CHECK VEHICLE MOVE

1. Move selector lever to P position.
2. Turn ignition switch to OFF position.
3. Release parking brake.

4. Push vehicle forward or backward.
5. Does vehicle move when it is pushed forward or backward?
6. Apply parking brake.

Yes or No

- Yes >> Mark the box on the DIAGNOSTIC WORKSHEET. Go to [AT-216, "3. In P Position, Vehicle Moves Forward or Backward When Pushed"](#). Continue ROAD TEST.
- No >> GO TO 4.

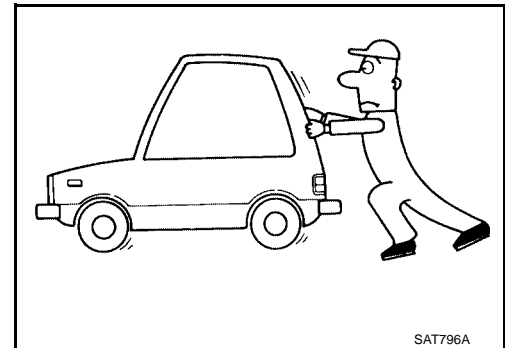
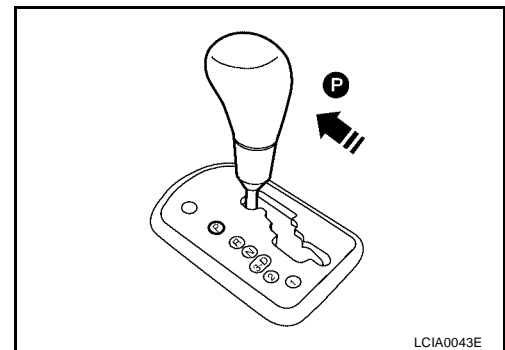

4. CHECK VEHICLE MOVE

1. Start engine.
2. Move selector lever to N position.
3. Release parking brake.
4. Does vehicle move forward or backward?

Yes or No

- Yes >> Mark the box on the DIAGNOSTIC WORKSHEET. Go to [AT-217, "4. In N Position, Vehicle Moves"](#). Continue ROAD TEST.
- No >> GO TO 5.

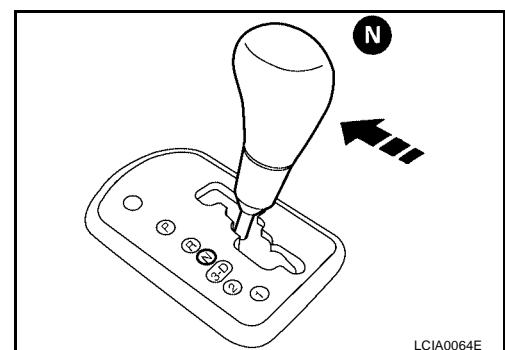

TROUBLE DIAGNOSIS - BASIC INSPECTION

5. CHECK SHIFT LOCK

1. Apply foot brake.

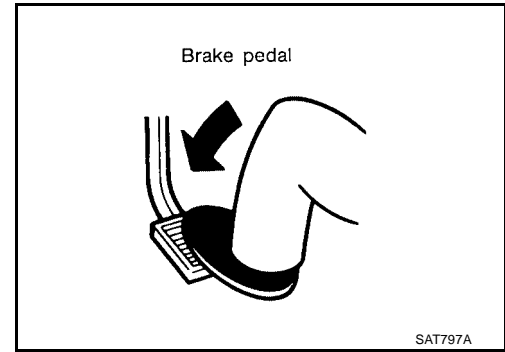

2. Move selector lever to R position.
3. Is there large shock when changing from N to R position?

Yes or No

- Yes >> Mark the box on the DIAGNOSTIC WORKSHEET. Go to [AT-219, "5. Large Shock. N → R Position"](#) . Continue ROAD TEST.
- No >> GO TO 6.

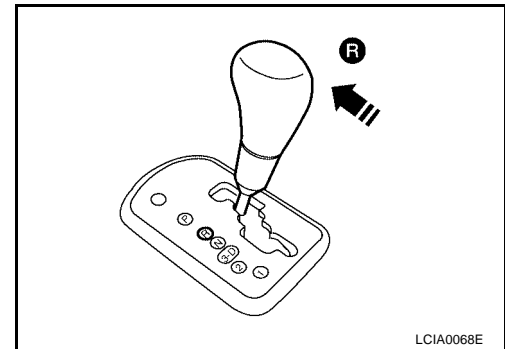

6. CHECK VEHICLE MOVE

1. Release foot brake for several seconds.
2. Does vehicle creep backward when foot brake is released?

Yes or No

- Yes >> GO TO 7.
- No >> Mark the box on the DIAGNOSTIC WORKSHEET. Go to [AT-221, "6. Vehicle Does Not Creep Backward In R Position"](#) . Continue ROAD TEST.

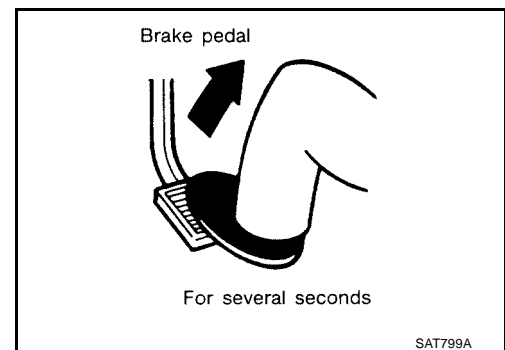

7. CHECK VEHICLE MOVE

1. Move selector lever to D, 2 and 1 positions and check if vehicle creeps forward.
2. Does vehicle creep forward in all three positions?

Yes or No

- Yes >> Go to [AT-70, "3. CRUISE TEST"](#) .
- No >> Mark the box on the DIAGNOSTIC WORKSHEET. Go to [AT-224, "7. Vehicle Does Not Creep Forward in D, 3, 2 or 1 Position"](#) . Continue ROAD TEST.

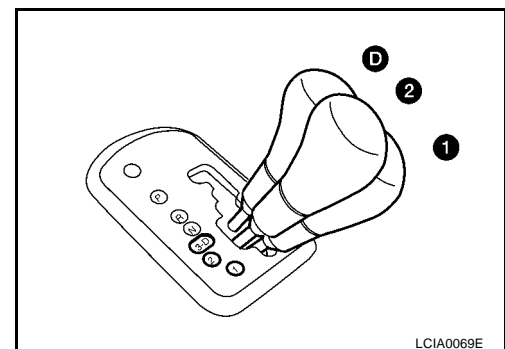

3. CRUISE TEST

- Check all items listed in Parts 1 through 3.

TROUBLE DIAGNOSIS - BASIC INSPECTION

④ With CONSULT-II

- Using CONSULT-II, conduct a cruise test and record the result.
- Print the result and ensure that shifts and lock-ups take place as per Shift Schedule. Refer to [AT-373, "Shift Schedule"](#)

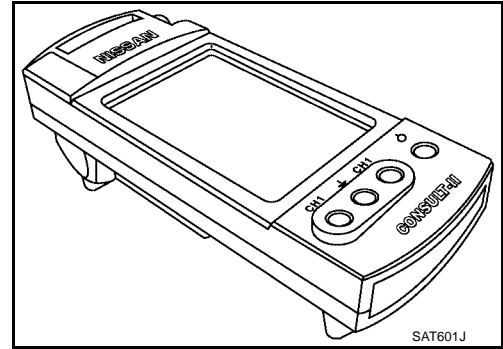

CONSULT-II Setting Procedure

1. Turn ignition switch OFF.
2. Connect CONSULT-II to data link connector, which is located in left side dash panel.

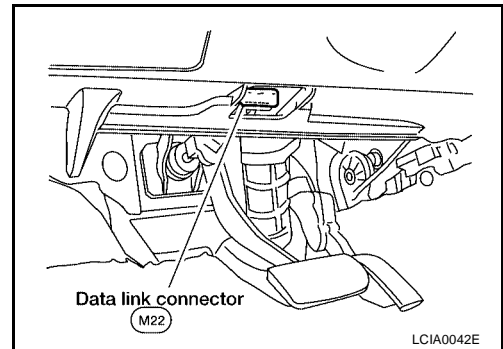

3. Turn ignition switch ON.
4. Touch "START (NISSAN BASED VHCL)".

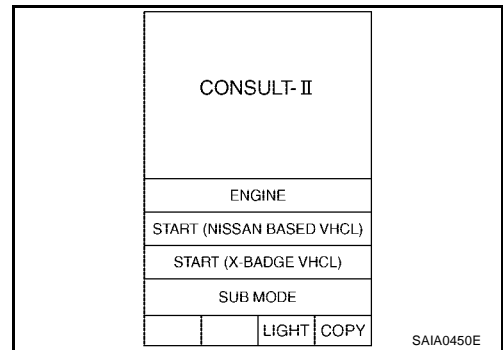

5. Touch "A/T".

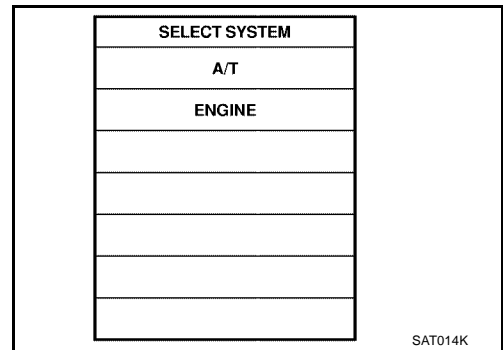

A

B

AT

D

E

F

G

H

I

J

K

L

M

TROUBLE DIAGNOSIS - BASIC INSPECTION

6. Touch "DATA MONITOR".

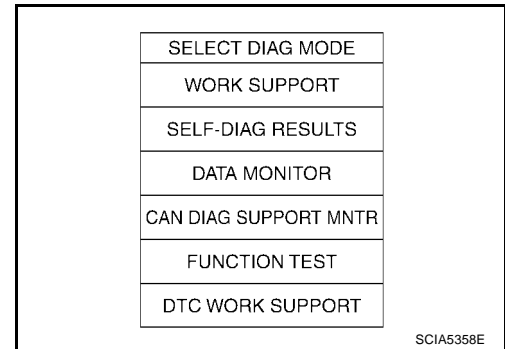

7. Touch "MAIN SIGNALS" or "TCM INPUT SIGNALS".

8. See "Numerical Display", "Barchart Display" or "Line Graph Display".

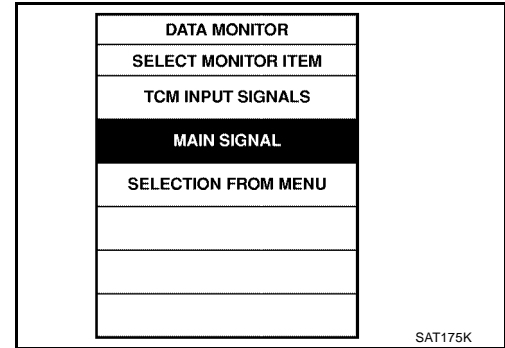

9. Touch "SETTING" to set recording condition ("AUTO TRIG" or "MANU TRIG") and touch "BACK".

10. Touch "Start".

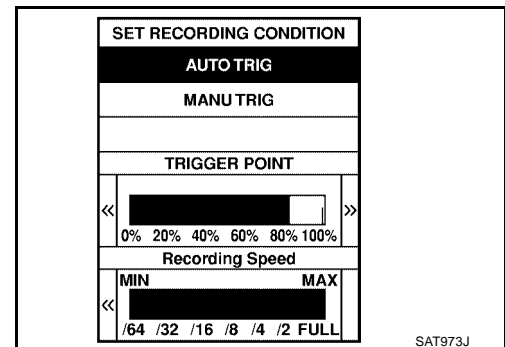

11. When performing cruise test, touch "RECORD".

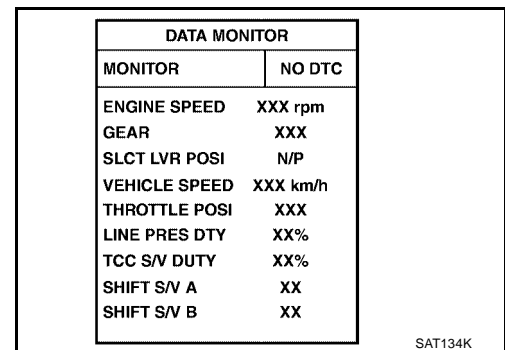

TROUBLE DIAGNOSIS - BASIC INSPECTION

12. After finishing cruise test part 1, touch "STOP".

DATA MONITOR		
Recording Data	X%	DTC
		DETECTED
ENGINE SPEED	XXX rpm	
GEAR	XXX	
SLCT LVR POSI	N/P	
VEHICLE SPEED	XXX km/h	
THROTTLE POSI	XXX	
LINE PRES DTY	XX%	
TCC S/V DUTY	XX%	
SHIFT S/V A	XX	
SHIFT S/V B	XX	

SAT135K

A
B
AT

13. Touch "STORE" and touch "BACK".

REAL-TIME DIAG
ENG SPEED SIG

SAT987J

D
E
F
G
H

STORE	
SYSTEM	SAVE REC DATA

SAT974J

I
J
K

- 14. Touch "DISPLAY".
- 15. Touch "PRINT".
- 16. Check the monitor data printed out.
- 17. Continue cruise test part 2 and 3.

Trigger	VHCL S/SEN A/T	VHCL S/SEN MTR	THRTL POSI SEN
	km/h	km/h	V

SAT975J

L
M

TROUBLE DIAGNOSIS - BASIC INSPECTION

⊗ Without CONSULT-II

- Throttle position sensor can be checked by voltage across terminals 41 (W) and 42 (B) of TCM.

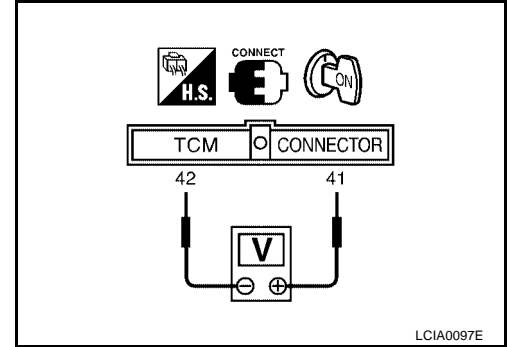

TROUBLE DIAGNOSIS - BASIC INSPECTION

Cruise Test — Part 1

1. CHECK STARTING GEAR (D1) POSITION

1. Drive vehicle for approximately 10 minutes to warm engine oil and ATF up to operating temperature.

ATF operating temperature :50 - 80°C (122 - 176°F)

2. Park vehicle on flat surface.
3. Set gear selector lever to P position.
4. Move selector lever to P position.
5. Start engine.

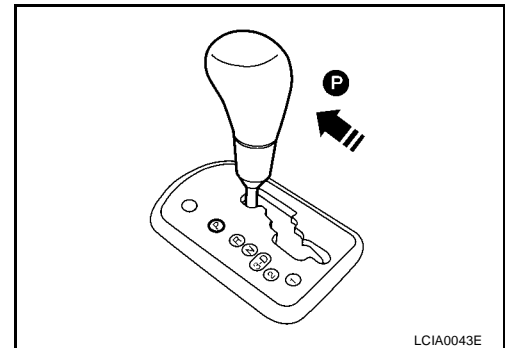

6. Move selector lever to D position.

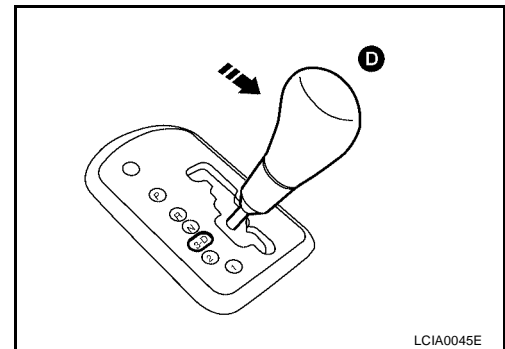

7. Accelerate vehicle by constantly depressing accelerator pedal half-way.
8. Does vehicle start from D1 ?

 **Read gear position.**

Yes or No

- Yes >> GO TO 2.
No >> Go to [AT-227, "8. Vehicle Cannot Be Started From D1"](#).
Continue ROAD TEST.

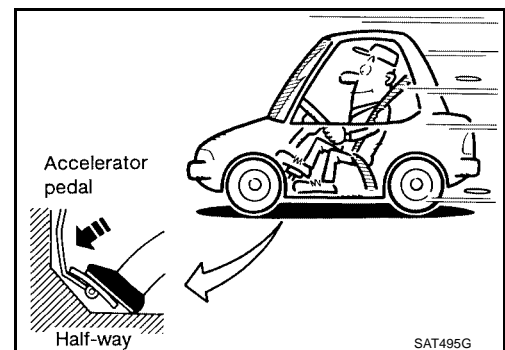

TROUBLE DIAGNOSIS - BASIC INSPECTION

2. CHECK SHIFT UP (D1 TO D2)

Does A/T shift from D1 to D2 at the specified speed?

① Read gear position, throttle opening and vehicle speed.

Specified speed when shifting from D1 to D2 :Refer to [AT-373, "Shift Schedule"](#) .

Yes or No

Yes >> GO TO 3.

No >> Go to [AT-230, "9. A/T Does Not Shift: D1 → D2 or Does Not Kickdown: D4 → D2"](#) . Continue ROAD TEST.

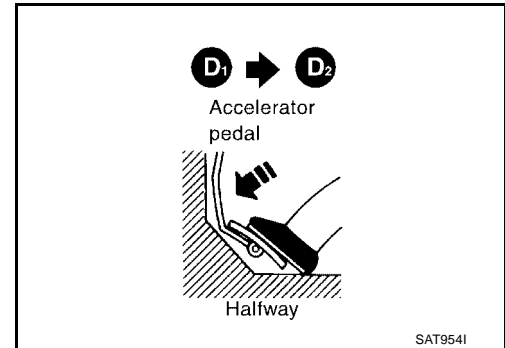

3. CHECK SHIFT UP (D2 TO D3)

Does A/T shift from D2 to D3 at the specified speed?

① Read gear position, throttle opening and vehicle speed.

Specified speed when shifting from D2 to D3 :Refer to [AT-373, "Shift Schedule"](#) .

Yes or No

Yes >> GO TO 4.

No >> Go to [AT-233, "10. A/T Does Not Shift: D2 → D3"](#) . Continue ROAD TEST.

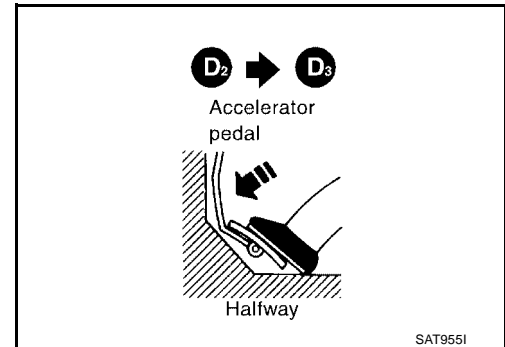

4. CHECK SHIFT UP (D3 TO D4)

Does A/T shift from D3 to D4 at the specified speed?

① Read gear position, throttle opening and vehicle speed.

Specified speed when shifting from D3 to D4 :Refer to [AT-373, "Shift Schedule"](#) .

Yes or No

Yes >> GO TO 5.

No >> Go to [AT-236, "11. A/T Does Not Shift: D3 → D4"](#) . Continue ROAD TEST.

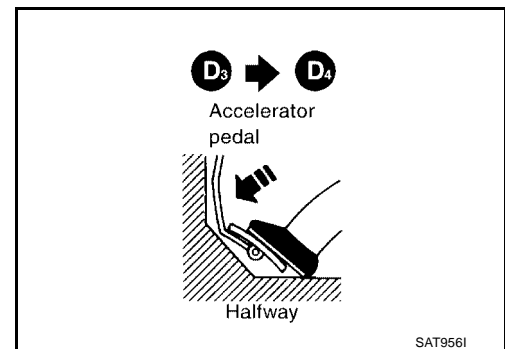

TROUBLE DIAGNOSIS - BASIC INSPECTION

5. CHECK LOCK-UP (D4 TO D4 L/U)

Does A/T perform lock-up at the specified speed?

 **Read vehicle speed, throttle opening when lock-up duty becomes 94%.**

Specified speed when lock-up occurs :Refer to [AT-373, "Shift Schedule"](#) .

Yes or No

Yes >> GO TO 6.

No >> Go to [AT-239, "12. A/T Does Not Perform Lock-up"](#) . Continue ROAD TEST.

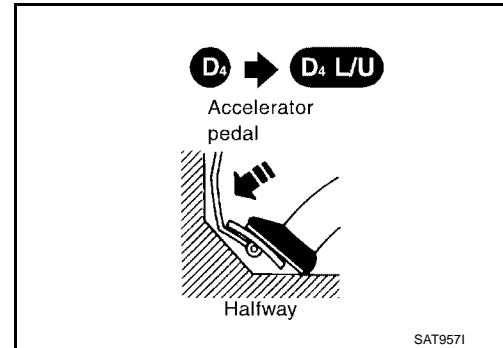

6. CHECK HOLD LOCK-UP

Does A/T hold lock-up condition for more than 30 seconds?

Yes or No

Yes >> GO TO 7.

No >> Go to [AT-241, "13. A/T Does Not Hold Lock-up Condition"](#) .

7. CHECK SHIFT DOWN (D4 L/U TO D4)

1. Release accelerator pedal.
2. Is lock-up released when accelerator pedal is released?

Yes or No

Yes >> GO TO 8.

No >> Go to [AT-243, "14. Lock-up Is Not Released"](#) . Continue ROAD TEST.

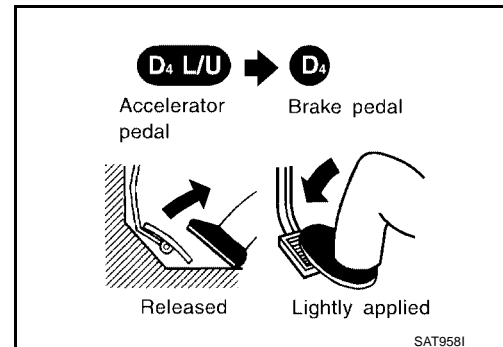

8. CHECK SHIFT DOWN (D4 TO D3)

1. Decelerate vehicle by applying foot brake lightly.
2. Does engine speed return to idle smoothly when A/T is shifted from D4 to D3 ?

 **Read gear position and engine speed.**

Yes or No

Yes >> 1. Stop vehicle.

2. Go to [AT-78, "Cruise Test — Part 2"](#) .

No >> Go to [AT-244, "15. Engine Speed Does Not Return To Idle \(Light Braking D4 → D3\)"](#) . Continue ROAD TEST.

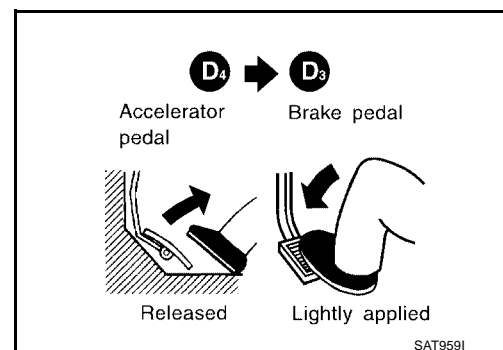

TROUBLE DIAGNOSIS - BASIC INSPECTION

Cruise Test — Part 2

1. CHECK STARTING GEAR (D1) POSITION

1. Confirm gear selector lever is in D position.
2. Accelerate vehicle by half throttle again.
3. Does vehicle start from D1 ?

 **Read gear position.**

Yes or No

Yes >> GO TO 2.

No >> Go to [AT-246, "16. Vehicle Does Not Start From D1"](#) .
Continue ROAD TEST.

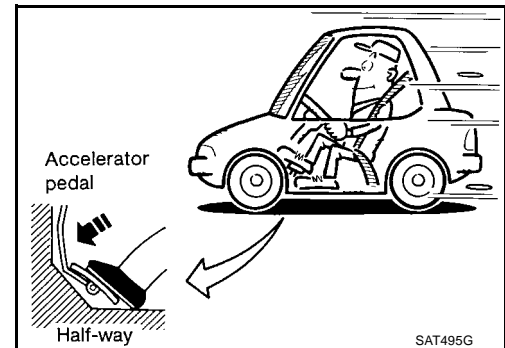

2. CHECK SHIFT UP AND SHIFT DOWN (D3 TO D4 TO D2)

1. Accelerate vehicle to 80 km/h (50 MPH) as shown in illustration.
2. Release accelerator pedal and then quickly depress it fully.
3. Does A/T shift from D4 to D2 as soon as accelerator pedal is depressed fully?

 **Read gear position and throttle opening.**

Yes or No

Yes >> GO TO 3.

No >> Go to [AT-230, "9. A/T Does Not Shift: D1 → D2 or Does Not Kickdown: D4 → D2"](#) . Continue ROAD TEST.

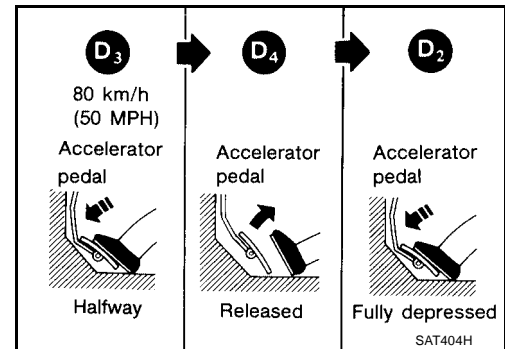

3. CHECK SHIFT UP (D2 TO D3)

Does A/T shift from D2 to D3 at the specified speed?

 **Read gear position, throttle opening and vehicle speed.**

Specified speed when shifting from D2 to D3 :Refer to [AT-373, "Shift Schedule"](#) .

Yes or No

Yes >> GO TO 4.

No >> Go to [AT-233, "10. A/T Does Not Shift: D2 → D3"](#) . Continue ROAD TEST.

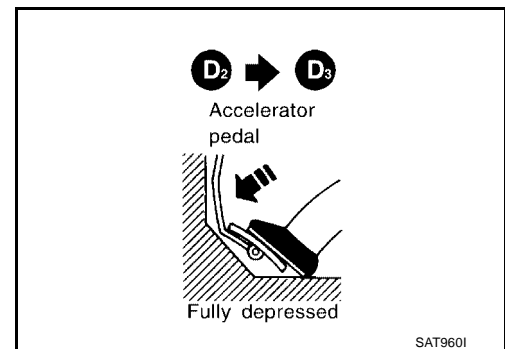

TROUBLE DIAGNOSIS - BASIC INSPECTION

4. CHECK SHIFT UP (D₃ TO D₄) AND ENGINE BRAKE

Release accelerator pedal after shifting from D₂ to D₃.

Does A/T shift from D₃ to D₄ and does vehicle decelerate by engine brake?

 **Read gear position, throttle opening and vehicle speed.**

Yes or No

- Yes >> 1. Stop vehicle.
2. Go to [AT-80, "Cruise Test — Part 3"](#).
- No >> Go to [AT-236, "11. A/T Does Not Shift: D₃ → D₄"](#). Continue ROAD TEST.

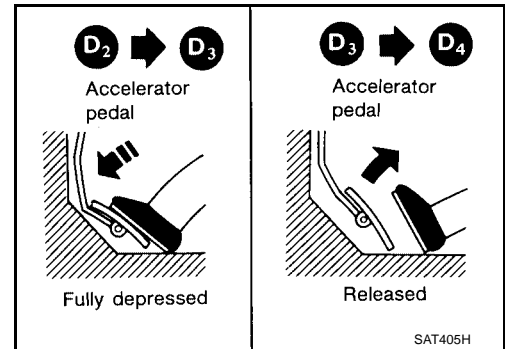

A
B
AT
D
E
F
G
H
I
J
K
L
M

TROUBLE DIAGNOSIS - BASIC INSPECTION

Cruise Test — Part 3

1. VEHICLE SPEED (D4) POSITION

1. Confirm gear selector lever is in D position.
2. Using half-throttle, accelerate vehicle until it shifts into D4 .

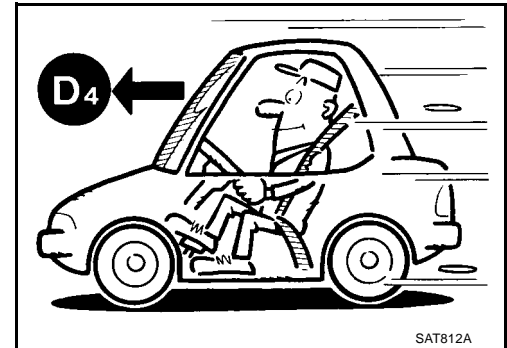

3. Release accelerator pedal.
4. Move gear selector lever from D position to 3 position while driving in D4 .
5. Does A/T shift from D4 to 3?
 Read gear position and vehicle speed.

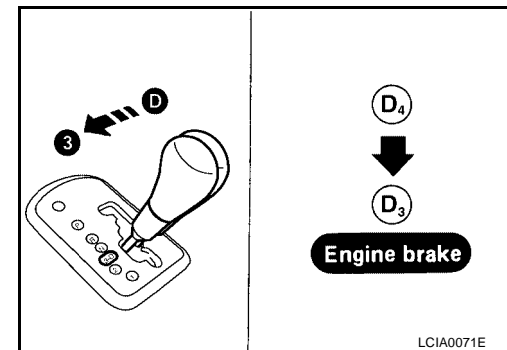
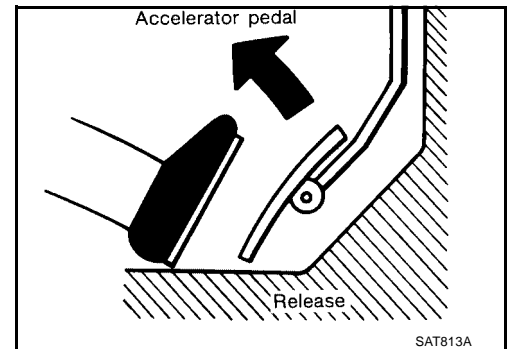

Yes or No

Yes >> GO TO 2.

No >> Go to [AT-247, "17. A/T Does Not Shift: D4 → 3₃ , When A/T Selector Lever D → 3"](#) . Continue ROAD TEST.

2. CHECK ENGINE BRAKE

Does vehicle decelerate by engine brake?

Yes or No

Yes >> GO TO 3.

No >> Go to [AT-244, "15. Engine Speed Does Not Return To Idle \(Light Braking D4 → D3\)"](#) . Continue ROAD TEST.

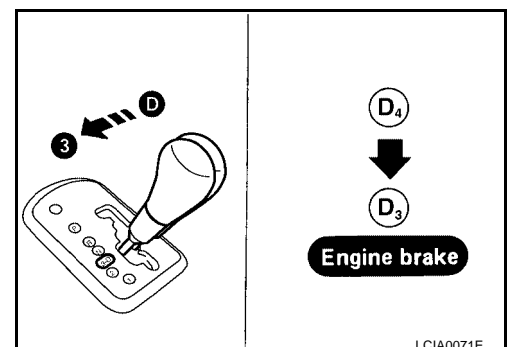

TROUBLE DIAGNOSIS - BASIC INSPECTION

3. CHECK SHIFT DOWN (3₃ TO 2₂)

1. Move selector lever from 3 to 2 position while driving in 3₃ .
2. Does A/T shift from 3₃ to 2₂ ?

 **Read gear position.**

Yes or No

- Yes >> GO TO 4.
No >> Go to [AT-248, "18. A/T Does Not Shift: 3₃ → 2₂ , When Selector Lever 3 → 2 Position"](#) . Continue ROAD TEST.

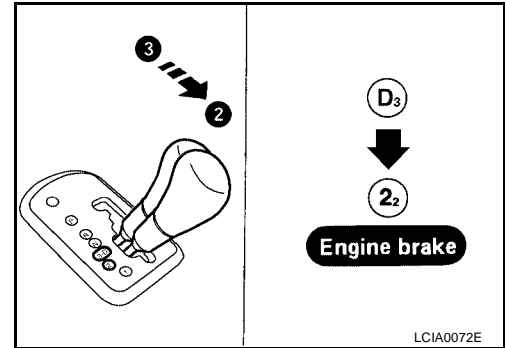

4. CHECK ENGINE BRAKE

Does vehicle decelerate by engine brake?

Yes or No

- Yes >> GO TO 5.
No >> Go to [AT-244, "15. Engine Speed Does Not Return To Idle \(Light Braking D₄ → D₃\)"](#) . Continue ROAD TEST.

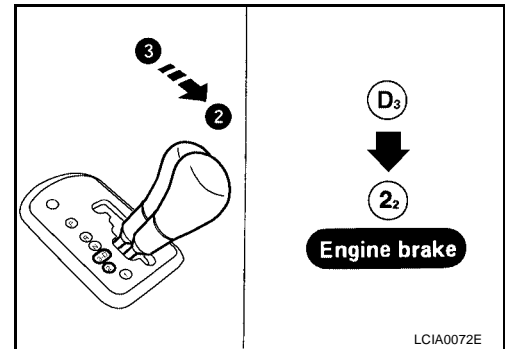

5. CHECK SHIFT DOWN (2₂ TO 1₁)

1. Move selector lever from 2 to 1 position while driving in 2₂ .
2. Does A/T shift from 2₂ to 1₁ position?

 **Read gear position.**

Yes or No

- Yes >> GO TO 6.
No >> Go to [AT-249, "19. A/T Does Not Shift: 2₂ → 1₁ , When Selector Lever 2 → 1 Position"](#) . Continue ROAD TEST.

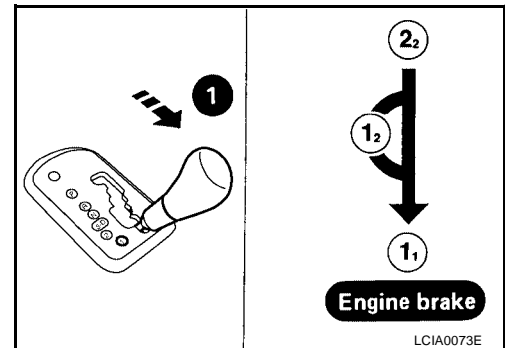

6. CHECK ENGINE BRAKE

Does vehicle decelerate by engine brake?

Yes or No

- Yes >> 1. Stop vehicle.
2. Perform self-diagnosis. Refer to [AT-51, "TCM SELF-DIAGNOSTIC PROCEDURE \(NO TOOLS\)"](#) .
No >> Go to [AT-250, "20. Vehicle Does Not Decelerate By Engine Brake"](#) . Continue ROAD TEST.

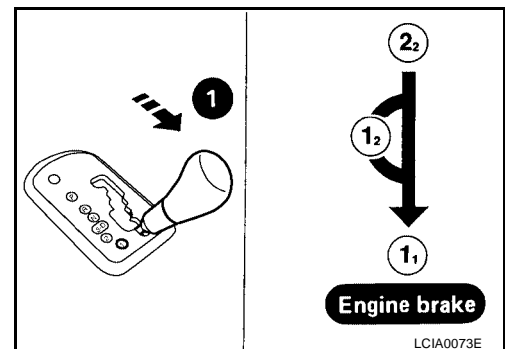

TROUBLE DIAGNOSIS - GENERAL DESCRIPTION

TROUBLE DIAGNOSIS - GENERAL DESCRIPTION

PFP:00000

Symptom Chart

ECS006AQ

Numbers are arranged in order of inspection.
Perform inspections starting with number one and work up.

Items	Symptom	Condition	Diagnostic Item	Reference Page
No Lock-up Engagement/ TCC Inoperative	Torque converter is not locked up.	ON vehicle	1. Throttle position sensor [accelerator pedal position (APP) sensor] adjustment	EC-48 (with QR25DE) EC-661 (with VQ35DE)
			2. Vehicle speed sensor-A/T (Revolution sensor) and vehicle speed sensor-MTR	AT-115 , AT-196
			3. Park/neutral position (PNP) switch adjustment	AT-266
			4. Engine speed signal	AT-120
			5. A/T fluid temperature sensor	AT-109
			6. Line pressure test	AT-65
			7. Torque converter clutch solenoid valve	AT-146
			8. Control valve assembly	AT-264
		OFF vehicle	9. Torque converter	AT-277
	Torque converter clutch piston slip.	ON vehicle	1. Fluid level	AT-61
			2. Throttle position sensor [accelerator pedal position (APP) sensor] adjustment	EC-48 (with QR25DE) EC-661 (with VQ35DE)
			3. Line pressure test	AT-65
			4. Torque converter clutch solenoid valve	AT-146
			5. Line pressure solenoid valve	AT-159
			6. Control valve assembly	AT-264
	OFF vehicle	7. Torque converter	AT-277	
Lock-up point is extremely high or low.	ON vehicle	1. Throttle position sensor [accelerator pedal position (APP) sensor] adjustment	EC-48 (with QR25DE) EC-661 (with VQ35DE)	
		2. Vehicle speed sensor-A/T (Revolution sensor) and vehicle speed sensor-MTR	AT-115 , AT-196	
		3. Torque converter clutch solenoid valve	AT-146	
		4. Control valve assembly	AT-264	
Shift Shock	ON vehicle	1. Engine idling rpm	EC-37 , EC-661	
		2. Throttle position sensor [accelerator pedal position (APP) sensor] adjustment	EC-48 (with QR25DE) EC-661 (with VQ35DE)	
		3. Line pressure test	AT-65	
		4. A/T fluid temperature sensor	AT-109	
		5. Engine speed signal	AT-120	
		6. Line pressure solenoid valve	AT-159	
		7. Control valve assembly	AT-264	
		8. Accumulator N-D	AT-277	
		OFF vehicle	9. Forward clutch	AT-322

TROUBLE DIAGNOSIS - GENERAL DESCRIPTION

Items	Symptom	Condition	Diagnostic Item	Reference Page
Shift Shock	Too sharp a shock in change from D1 to D2 .	ON vehicle	1. Throttle position sensor [accelerator pedal position (APP) sensor] adjustment	EC-48 (with QR25DE) EC-661 (with VQ35DE)
			2. Line pressure test	AT-65
			3. Accumulator servo release	AT-277
			4. Control valve assembly	AT-264
			5. A/T fluid temperature sensor	AT-109
		OFF vehicle	6. Brake band	AT-277
	Too sharp a shock in change from D2 to D3 .	ON vehicle	1. Throttle position sensor [accelerator pedal position (APP) sensor] adjustment	EC-48 (with QR25DE) EC-661 (with VQ35DE)
			2. Line pressure test	AT-65
			3. Control valve assembly	AT-264
		OFF vehicle	4. High clutch	AT-317
			5. Brake band	AT-277
	Too sharp a shock in change from D3 to D4 .	ON vehicle	1. Throttle position sensor [accelerator pedal position (APP) sensor] adjustment	EC-48 (with QR25DE) EC-661 (with VQ35DE)
			2. Line pressure test	AT-65
			3. Control valve assembly	AT-264
		OFF vehicle	4. Brake band	AT-277
			5. Overrun clutch	AT-322
	Gear change shock felt during deceleration by releasing accelerator pedal.	ON vehicle	1. Throttle position sensor [accelerator pedal position (APP) sensor] adjustment	EC-48 (with QR25DE) EC-661 (with VQ35DE)
			2. Line pressure test	AT-65
3. Overrun clutch solenoid valve			AT-181	
4. Control valve assembly			AT-264	
Large shock changing from 12 to 11 in 1 position.	ON vehicle	1. Control valve assembly	AT-264	
	ON vehicle	2. Low & reverse brake	AT-328	
Improper Shift Timing	Too high a gear change point from D1 to D2 , from D2 to D3 , from D3 to D4 .	ON vehicle	1. Throttle position sensor [accelerator pedal position (APP) sensor] adjustment	EC-48 (with QR25DE) EC-661 (with VQ35DE)
			2. Vehicle speed sensor-A/T (Revolution sensor) and vehicle speed sensor-MTR	AT-115 , AT-196
			3. Shift solenoid valve A	AT-165
			4. Shift solenoid valve B	AT-170
	Gear change directly from D1 to D3 occurs.	ON vehicle	1. Fluid level	AT-61
		OFF vehicle	2. Accumulator servo release	AT-272
	Too high a change point from D4 to D3 , from D3 to D2 , from D2 to D1 .	ON vehicle	3. Brake band	AT-277
			1. Throttle position sensor [accelerator pedal position (APP) sensor] adjustment	EC-48 (with QR25DE) EC-661 (with VQ35DE)
	Kickdown does not operate when depressing pedal in D4 within kick-down vehicle speed.	ON vehicle	2. Vehicle speed sensor-A/T (Revolution sensor) and vehicle speed sensor-MTR	AT-115 , AT-196
			1. Throttle position sensor [accelerator pedal position (APP) sensor] adjustment	EC-48 (with QR25DE) EC-661 (with VQ35DE)
			2. Vehicle speed sensor-A/T (Revolution sensor) and vehicle speed sensor-MTR	AT-115 , AT-196
			3. Shift solenoid valve A	AT-165
	4. Shift solenoid valve B	AT-170		

TROUBLE DIAGNOSIS - GENERAL DESCRIPTION

Items	Symptom	Condition	Diagnostic Item	Reference Page
Improper Shift Timing	Kickdown operates or engine overruns when depressing pedal in D4 beyond kickdown vehicle speed limit.	ON vehicle	1. Vehicle speed sensor-A/T (Revolution sensor) and vehicle speed sensor-MTR	AT-115 , AT-196
			2. Throttle position sensor [accelerator pedal position (APP) sensor] adjustment	EC-48 (with QR25DE) EC-661 (with VQ35DE)
			3. Shift solenoid valve A	AT-165
			4. Shift solenoid valve B	AT-170
	Gear change from 22 to 23 in 2 position.	ON vehicle	1. Park/neutral position (PNP) switch adjustment	AT-266
	Gear change from 11 to 12 in 1 position.	ON vehicle	1. Park/neutral position (PNP) switch adjustment	AT-266
No Down Shift	Failure to change gear from D4 to D3 .	ON vehicle	1. Fluid level	AT-61
			2. Throttle position sensor [accelerator pedal position (APP) sensor] adjustment	EC-48 (with QR25DE) EC-661 (with VQ35DE)
			3. Overrun clutch solenoid valve	AT-181
			4. Shift solenoid valve A	AT-165
			5. Line pressure solenoid valve	AT-159
			6. Control valve assembly	AT-264
		OFF vehicle	7. Low & reverse brake	AT-328
			8. Overrun clutch	AT-322
	Failure to change gear from D3 to D2 or from D4 to D2 .	ON vehicle	1. Fluid level	AT-61
			2. Throttle position sensor [accelerator pedal position (APP) sensor] adjustment	EC-48 (with QR25DE) EC-661 (with VQ35DE)
			3. Shift solenoid valve A	AT-165
			4. Shift solenoid valve B	AT-170
			5. Control valve assembly	AT-264
		OFF vehicle	6. High clutch	AT-317
			7. Brake band	AT-277
	Failure to change gear from D2 to D1 or from D3 to D1 .	ON vehicle	1. Fluid level	AT-61
			2. Throttle position sensor [accelerator pedal position (APP) sensor] adjustment	EC-48 (with QR25DE) EC-661 (with VQ35DE)
			3. Shift solenoid valve A	AT-165
			4. Shift solenoid valve B	AT-170
			5. Control valve assembly	AT-264
OFF vehicle		6. Low one-way clutch	AT-277	
		7. High clutch	AT-317	
		8. Brake band	AT-277	

TROUBLE DIAGNOSIS - GENERAL DESCRIPTION

Items	Symptom	Condition	Diagnostic Item	Reference Page	
No Down Shift	Failure to change from D3 to 22 when changing lever into 2 position. AT-248	ON vehicle	1. Park/neutral position (PNP) switch adjustment	AT-266	A
			2. Throttle position sensor [accelerator pedal position (APP) sensor] adjustment	EC-48 (with QR25DE) EC-661 (with VQ35DE)	B
			3. Overrun clutch solenoid valve	AT-181	AT
			4. Shift solenoid valve B	AT-170	
			5. Shift solenoid valve A	AT-165	
			6. Control valve assembly	AT-264	D
			7. Control cable adjustment	AT-267	
		OFF vehicle	8. Brake band	AT-277	E
			9. Overrun clutch	AT-322	F
	Does not change from 12 to 11 in 1 position.	ON vehicle	1. Park/neutral position (PNP) switch adjustment	AT-266	G
			2. Vehicle speed sensor-A/T (Revolution sensor) and vehicle speed sensor-MTR	AT-115 , AT-196	H
			3. Shift solenoid valve A	AT-165	I
			4. Control valve assembly	AT-264	J
			5. Overrun clutch solenoid valve	AT-181	K
OFF vehicle		6. Overrun clutch	AT-322	L	
		7. Low & reverse brake	AT-328	M	
No Up Shift	Failure to change gear from D1 to D2 .	ON vehicle	1. Park/neutral position (PNP) switch adjustment	AT-266	A
			2. Control cable adjustment	AT-267	B
			3. Shift solenoid valve A	AT-165	C
			4. Control valve assembly	AT-264	D
			5. Vehicle speed sensor-A/T (Revolution sensor) and vehicle speed sensor-MTR	AT-115 , AT-196	E
		OFF vehicle	6. Brake band	AT-277	F
	Failure to change gear from D2 to D3 .	ON vehicle	1. Park/neutral position (PNP) switch adjustment	AT-266	G
			2. Control cable adjustment	AT-267	H
			3. Shift solenoid valve B	AT-170	I
			4. Control valve assembly	AT-264	J
			5. Vehicle speed sensor-A/T (Revolution sensor) and vehicle speed sensor-MTR	AT-115 , AT-196	K
		OFF vehicle	6. High clutch	AT-317	L
			7. Brake band	AT-277	M

TROUBLE DIAGNOSIS - GENERAL DESCRIPTION

Items	Symptom	Condition	Diagnostic Item	Reference Page	
No Up Shift	Failure to change gear from D ₃ to D ₄ .	ON vehicle	1. Park/neutral position (PNP) switch adjustment	AT-266	
			2. Control cable adjustment	AT-267	
			3. Shift solenoid valve A	AT-165	
			4. Vehicle speed sensor-A/T (Revolution sensor) and vehicle speed sensor-MTR	AT-115 , AT-196	
			5. A/T fluid temperature sensor	AT-109	
		OFF vehicle	6. Brake band	AT-277	
	A/T does not shift to D ₄ when driving with overdrive control switch ON.	ON vehicle		1. Throttle position sensor [accelerator pedal position (APP) sensor] adjustment	EC-48 (with QR25DE) EC-661 (with VQ35DE)
				2. Park/neutral position (PNP) switch adjustment	AT-266
				3. Vehicle speed sensor-A/T (Revolution sensor) and vehicle speed sensor-MTR	AT-115 , AT-196
				4. Shift solenoid valve A	AT-165
5. Overrun clutch solenoid valve				AT-181	
6. Control valve assembly				AT-264	
7. A/T fluid temperature sensor				AT-109	
8. Line pressure solenoid valve				AT-159	
		OFF vehicle	9. Brake band	AT-277	
			10. Overrun clutch	AT-322	
Slips/Will Not Engage	Vehicle will not run in R position (but runs in D, 2 and 1 positions). Clutch slips. Very poor acceleration.	ON vehicle	1. Control cable adjustment	AT-267	
			2. Line pressure test	AT-65	
			3. Line pressure solenoid valve	AT-159	
			4. Control valve assembly	AT-264	
		OFF vehicle	5. Reverse clutch	AT-314	
			6. High clutch	AT-317	
			7. Forward clutch	AT-322	
			8. Overrun clutch	AT-322	
			9. Low & reverse brake	AT-328	
	Vehicle will not run in D and 2 positions (but runs in 1 and R positions).	ON vehicle	1. Control cable adjustment	AT-267	
OFF vehicle		2. Low one-way clutch	AT-277		

TROUBLE DIAGNOSIS - GENERAL DESCRIPTION

Items	Symptom	Condition	Diagnostic Item	Reference Page	
Slips/Will Not Engage	Vehicle will not run in D, 1, 2 positions (but runs in R position). Clutch slips. Very poor acceleration.	ON vehicle	1. Fluid level	AT-61	A
			2. Line pressure test	AT-65	
			3. Line pressure solenoid valve	AT-159	B
			4. Control valve assembly	AT-264	
			5. Accumulator N-D	AT-277	
		OFF vehicle	6. Reverse clutch	AT-314	AT
			7. High clutch	AT-317	
			8. Forward clutch	AT-322	D
			9. Forward one-way clutch	AT-277	
			10. Low one-way clutch	AT-277	
	Clutches or brakes slip somewhat in starting.	ON vehicle	1. Fluid level	AT-61	E
			2. Control cable adjustment	AT-267	
			3. Throttle position sensor [accelerator pedal position (APP) sensor] adjustment	EC-48 (with QR25DE) EC-661 (with VQ35DE)	F
			4. Line pressure test	AT-65	
			5. Line pressure solenoid valve	AT-159	G
			6. Control valve assembly	AT-264	
			7. Accumulator N-D	AT-277	
		OFF vehicle	8. Forward clutch	AT-322	H
			9. Reverse clutch	AT-314	
			10. Low & reverse brake	AT-328	I
			11. Oil pump	AT-295	
			12. Torque converter	AT-277	
	No creep at all. AT-221 , AT-224	ON vehicle	1. Fluid level	AT-61	J
			2. Line pressure test	AT-65	
			3. Control valve assembly	AT-264	
		OFF vehicle	4. Forward clutch	AT-322	K
			5. Oil pump	AT-295	
			6. Torque converter	AT-277	L
Almost no shock or clutches slipping in change from D1 to D2 .	ON vehicle	1. Fluid level	AT-61		
		2. Throttle position sensor [accelerator pedal position (APP) sensor] adjustment	EC-48 (with QR25DE) EC-661 (with VQ35DE)	M	
		3. Line pressure test	AT-65		
		4. Accumulator servo release	AT-272		
		5. Control valve assembly	AT-264		
	OFF vehicle	6. Brake band	AT-277		

TROUBLE DIAGNOSIS - GENERAL DESCRIPTION

Items	Symptom	Condition	Diagnostic Item	Reference Page
Slips/Will Not Engage	Almost no shock or slipping in change from D2 to D3 .	ON vehicle	1. Fluid level	AT-61
			2. Throttle position sensor [accelerator pedal position (APP) sensor] adjustment	EC-48 (with QR25DE) EC-661 (with VQ35DE)
			3. Line pressure test	AT-65
			4. Control valve assembly	AT-264
		OFF vehicle	5. High clutch	AT-317
			6. Forward clutch	AT-322
	Almost no shock or slipping in change from D3 to D4 .	ON vehicle	1. Fluid level	AT-61
			2. Throttle position sensor [accelerator pedal position (APP) sensor] adjustment	EC-48 (with QR25DE) EC-661 (with VQ35DE)
			3. Line pressure test	AT-65
			4. Control valve assembly	AT-264
		OFF vehicle	5. High clutch	AT-317
			6. Brake band	AT-277
	Races extremely fast or slips in changing from D4 to D3 when depressing pedal.	ON vehicle	1. Fluid level	AT-61
			2. Throttle position sensor [accelerator pedal position (APP) sensor] adjustment	EC-48 (with QR25DE) EC-661 (with VQ35DE)
			3. Line pressure test	AT-65
			4. Line pressure solenoid valve	AT-159
			5. Control valve assembly	AT-264
		OFF vehicle	6. High clutch	AT-317
			7. Forward clutch	AT-322
	Races extremely fast or slips in changing from D4 to D2 when depressing pedal.	ON vehicle	1. Fluid level	AT-61
			2. Throttle position sensor [accelerator pedal position (APP) sensor] adjustment	EC-48 (with QR25DE) EC-661 (with VQ35DE)
			3. Line pressure test	AT-65
			4. Line pressure solenoid valve	AT-159
			5. Shift solenoid valve A	AT-165
6. Control valve assembly			AT-264	
OFF vehicle		7. Brake band	AT-277	
		8. Forward clutch	AT-322	
Races extremely fast or slips in changing from D3 to D2 when depressing pedal.	ON vehicle	1. Fluid level	AT-61	
		2. Throttle position sensor [accelerator pedal position (APP) sensor] adjustment	EC-48 (with QR25DE) EC-661 (with VQ35DE)	
		3. Line pressure test	AT-65	
		4. Line pressure solenoid valve	AT-159	
		5. Control valve assembly	AT-264	
		6. A/T fluid temperature sensor	AT-109	
	OFF vehicle	7. Brake band	AT-277	
		8. Forward clutch	AT-322	
		9. High clutch	AT-317	

TROUBLE DIAGNOSIS - GENERAL DESCRIPTION

Items	Symptom	Condition	Diagnostic Item	Reference Page	
Slips/Will Not Engage	Races extremely fast or slips in changing from D4 or D3 to D1 when depressing pedal.	ON vehicle	1. Fluid level	AT-61	A
			2. Throttle position sensor [accelerator pedal position (APP) sensor] adjustment	EC-48 (with QR25DE) EC-661 (with VQ35DE)	B
			3. Line pressure test	AT-65	AT
			4. Line pressure solenoid valve	AT-159	
			5. Control valve assembly	AT-264	
	OFF vehicle	6. Forward clutch	AT-322	D	
		7. Forward one-way clutch	AT-277	E	
		8. Low one-way clutch	AT-277	F	
	Vehicle will not run in any position.	ON vehicle	1. Fluid level	AT-61	G
			2. Control cable adjustment	AT-267	H
3. Line pressure test			AT-65	I	
4. Line pressure solenoid valve			AT-159	J	
OFF vehicle		5. Oil pump	AT-295	K	
		6. High clutch	AT-317	L	
		7. Brake band	AT-277	M	
		8. Low & reverse brake	AT-328		
		9. Torque converter	AT-277		
		10. Parking components	AT-292		
NOT USED	Engine cannot be started in P and N positions. AT-215	ON vehicle	1. Ignition switch and starter	SC-16	I
			2. Control cable adjustment	AT-267	J
			3. Park/neutral position (PNP) switch adjustment	AT-266	K
	Engine starts in positions other than P and N.	ON vehicle	1. Control cable adjustment	AT-267	L
			2. Park/neutral position (PNP) switch adjustment	AT-266	M
	Transaxle noise in P and N positions.	ON vehicle	1. Fluid level	AT-61	L
			2. Line pressure test	AT-65	M
			3. Throttle position sensor [accelerator pedal position (APP) sensor] adjustment	EC-48 (with QR25DE) EC-661 (with VQ35DE)	
			4. Vehicle speed sensor-A/T (Revolution sensor) and vehicle speed sensor-MTR	AT-115 , AT-196	
			5. Engine speed signal	AT-120	
		OFF vehicle	6. Oil pump	AT-295	
			7. Torque converter	AT-277	
Vehicle moves when changing into P position or parking gear does not disengage when shifted out of P position.	ON vehicle	1. Control cable adjustment	AT-267		
	OFF vehicle	2. Parking components	AT-292		

TROUBLE DIAGNOSIS - GENERAL DESCRIPTION

Items	Symptom	Condition	Diagnostic Item	Reference Page
NOT USED	Vehicle runs in N position. AT-217	ON vehicle	1. Control cable adjustment	AT-267
		OFF vehicle	2. Forward clutch	AT-322
			3. Reverse clutch	AT-314
			4. Overrun clutch	AT-322
	Vehicle braked when shifting into R position.	ON vehicle	1. Fluid level	AT-61
			2. Control cable adjustment	AT-267
			3. Line pressure test	AT-65
			4. Line pressure solenoid valve	AT-159
			5. Control valve assembly	AT-264
		OFF vehicle	6. High clutch	AT-317
			7. Brake band	AT-277
			8. Forward clutch	AT-322
			9. Overrun clutch	AT-322
	Excessive creep.	ON vehicle	1. Engine idling rpm	EC-37 , EC-661
	Engine stops when shifting lever into R, D, 2 and 1.	ON vehicle	1. Engine idling rpm	EC-37 , EC-661
			2. Torque converter clutch solenoid valve	AT-146
			3. Control valve assembly	AT-264
		OFF vehicle	4. Torque converter	AT-277
	Vehicle braked by gear change from D1 to D2 .	ON vehicle	1. Fluid level	AT-61
		OFF vehicle	2. Reverse clutch	AT-314
			3. Low & reverse brake	AT-328
			4. High clutch	AT-317
			5. Low one-way clutch	AT-277
Vehicle braked by gear change from D2 to D3 .	ON vehicle	1. Fluid level	AT-61	
	OFF vehicle	2. Brake band	AT-277	
Vehicle braked by gear change from D3 to D4 .	ON vehicle	1. Fluid level	AT-61	
	OFF vehicle	2. Overrun clutch	AT-322	
		3. Forward one-way clutch	AT-277	
		4. Reverse clutch	AT-314	

TROUBLE DIAGNOSIS - GENERAL DESCRIPTION

Items	Symptom	Condition	Diagnostic Item	Reference Page	
NOT USED	Maximum speed not attained. Acceleration poor.	ON vehicle	1. Fluid level	AT-61	A
			2. Park/neutral position (PNP) switch adjustment	AT-266	B
			3. Shift solenoid valve A	AT-165	AT
			4. Shift solenoid valve B	AT-170	
			5. Control valve assembly	AT-264	
		OFF vehicle	6. Reverse clutch	AT-314	D
			7. High clutch	AT-317	
			8. Brake band	AT-277	E
			9. Low & reverse brake	AT-328	
			10. Oil pump	AT-295	
			11. Torque converter	AT-277	
	Transaxle noise in D, 2, 1 and R positions.	ON vehicle	1. Fluid level	AT-61	F
		ON vehicle	2. Torque converter	AT-277	
	Engine brake does not operate in "1" position.	ON vehicle	1. Park/neutral position (PNP) switch adjustment	AT-266	G
			2. Control cable adjustment	AT-267	
			3. Throttle position sensor [accelerator pedal position (APP) sensor] adjustment	EC-48 (with QR25DE) EC-661 (with VQ35DE)	H
			4. Vehicle speed sensor-A/T (Revolution sensor) and vehicle speed sensor-MTR	AT-115 , AT-196	
			5. Shift solenoid valve A	AT-165	I
			6. Control valve assembly	AT-264	
			7. Overrun clutch solenoid valve	AT-181	J
		OFF vehicle	8. Overrun clutch	AT-322	
			9. Low & reverse brake	AT-328	
	Transaxle overheats.	ON vehicle	1. Fluid level	AT-61	K
2. Engine idling rpm			EC-37 , EC-661		
3. Throttle position sensor [accelerator pedal position (APP) sensor] adjustment			EC-48 (with QR25DE) EC-661 (with VQ35DE)	L	
4. Line pressure test			AT-65		
5. Line pressure solenoid valve			AT-159	M	
6. Control valve assembly			AT-264		
OFF vehicle		7. Oil pump	AT-295		
		8. Reverse clutch	AT-314		
		9. High clutch	AT-317		
		10. Brake band	AT-277		
		11. Forward clutch	AT-322		
		12. Overrun clutch	AT-322		
		13. Low & reverse brake	AT-328		
		14. Torque converter	AT-277		

TROUBLE DIAGNOSIS - GENERAL DESCRIPTION

Items	Symptom	Condition	Diagnostic Item	Reference Page
NOT USED	ATF shoots out during operation. White smoke emitted from exhaust pipe during operation.	ON vehicle	1. Fluid level	AT-61
		OFF vehicle	2. Reverse clutch	AT-314
			3. High clutch	AT-317
			4. Brake band	AT-277
			5. Forward clutch	AT-322
			6. Overrun clutch	AT-322
			7. Low & reverse brake	AT-328
	Offensive smell at fluid charging pipe.	ON vehicle	1. Fluid level	AT-61
		OFF vehicle	2. Torque converter	AT-277
			3. Oil pump	AT-295
			4. Reverse clutch	AT-314
			5. High clutch	AT-317
			6. Brake band	AT-277
			7. Forward clutch	AT-322
			8. Overrun clutch	AT-322
9. Low & reverse brake			AT-328	
Engine is stopped at R, D, 2 and 1 positions.	ON vehicle	1. Fluid level	AT-61	
		2. Torque converter clutch solenoid valve	AT-146	
		3. Shift solenoid valve B	AT-170	
		4. Shift solenoid valve A	AT-165	
		5. Control valve assembly	AT-264	

TCM Terminals and Reference Value PREPARATION

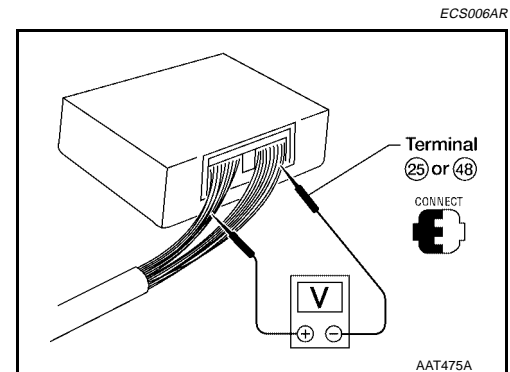

- Measure voltage between each terminal and terminal 25 or 48 by following "TCM INSPECTION TABLE".



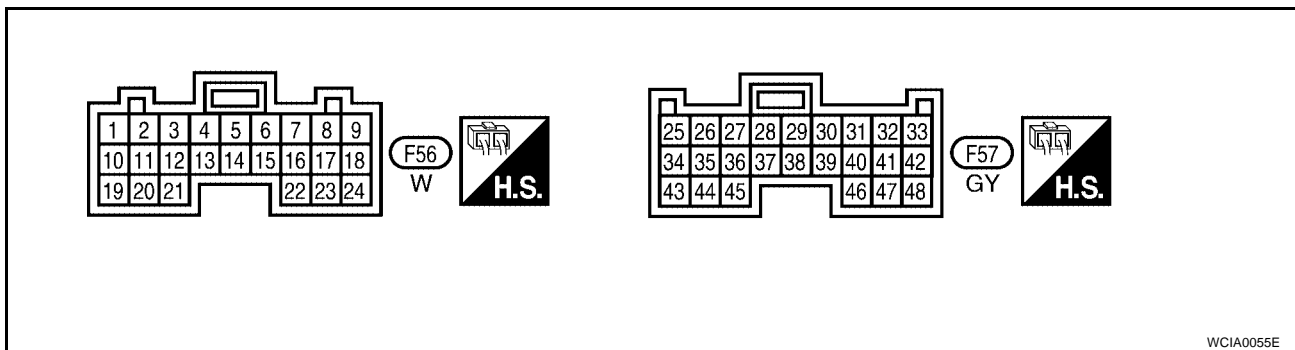









TCM HARNESS CONNECTOR TERMINAL LAYOUT











TROUBLE DIAGNOSIS - GENERAL DESCRIPTION

TCM INSPECTION TABLE

(Data are reference values.)

Terminal No.	Wire color	Item	Condition		Judgement standard (Approx.)
1	G/R	Line pressure solenoid valve		When releasing accelerator pedal after warming up engine.	1.5 - 3.0V
				When depressing accelerator pedal fully after warming up engine.	0V
2	W/B	Line pressure solenoid valve (with dropping resistor)		When releasing accelerator pedal after warming up engine.	4 - 14V
				When depressing accelerator pedal fully after warming up engine.	0V
3	G/B	Torque converter clutch solenoid valve		When A/T performs lock-up.	8 - 15V
				When A/T does not perform lock-up.	0V
5*	L	CAN-H	—	—	—
6*	Y	CAN-L	—	—	—
10	R/Y	Power source	 or 	With ignition switch ON.	Battery voltage
				With ignition switch OFF.	0V
11	R/Y	Shift solenoid valve A		When shift solenoid valve A operates. (When driving in D1 or D4 .)	Battery voltage
				When shift solenoid valve A does not operate. (When driving in D2 or D3 .)	0V
12	LG/B	Shift solenoid valve B		When shift solenoid valve B operates. (When driving in D1 or D2 .)	Battery voltage
				When shift solenoid valve B does not operate. (When driving in D3 or D4 .)	0V
19	R/Y	Power source	Same as No. 10		
20	BR/Y	Overrun clutch solenoid valve		When overrun clutch solenoid valve operates.	Battery voltage
				When overrun clutch solenoid valve does not operate.	0V
25	B	Ground	—	—	—
26	PU/W	PNP switch 1 position		When setting selector lever to 1 position.	Battery voltage
				When setting selector lever to other positions.	0V
27	P/B	PNP switch 2 position		When setting selector lever to 2 position.	Battery voltage
				When setting selector lever to other positions.	0V
28	Y/R	Power source (Memory back-up)	 or 	With ignition switch OFF.	Battery voltage
				With ignition switch ON.	Battery voltage

TROUBLE DIAGNOSIS - GENERAL DESCRIPTION

Terminal No.	Wire color	Item	Condition		Judgement standard (Approx.)
29	W	Revolution sensor		When moving at 20 km/h (12 MPH), use the CONSULT-II pulse frequency measuring function.*1 CAUTION: Connect the diagnosis data link cable to the vehicle diagnosis connector. *1: A circuit tester cannot be used to test this item.	450 Hz
				When vehicle is parked.	Under 1.3V or over 4.5V
30**	BR/Y	Data link connector (RX)		—	—
31**	LG	Data link connector (TX)		—	—
32	R	Sensor power		Ignition switch ON.	4.5 - 5.5V
			Ignition switch OFF.	0V	
34	G	PNP switch D position		When setting selector lever to D position.	Battery voltage
				When setting selector lever to other positions.	0V
35	G/W	PNP switch R position		When setting selector lever to R position.	Battery voltage
				When setting selector lever to other positions.	0V
36	R/B	PNP switch P or N position		When setting selector lever to P or N position.	Battery voltage
				When setting selector lever to other positions.	0V
38	G	Turbine revolution sensor		When moving at 20 km/h (12 MPH), use the CONSULT-II pulse frequency measuring function.*1 CAUTION: Connect the diagnosis data link cable to the vehicle diagnosis connector. *1: A circuit tester cannot be used to test this item.	240 Hz
				When vehicle is parked.	Under 1.3V or over 4.5V
39	W/G	Engine speed signal	 	Refer to EC-99, "ECM INSPECTION TABLE" (with QR25DE), or EC-727, "ECM INSPECTION TABLE" (with VQ35DE).	
40	PU/R	Vehicle speed sensor		When moving vehicle at 2 to 3 km/h (1 to 2 MPH) for 1 m (3 ft) or more.	Voltage varies between less than 1V and more than 4.5V
41	W	Throttle position sensor [accelerator pedal position (APP) sensor]		When depressing accelerator pedal slowly after warming up engine. (Voltage rises gradually in response to throttle position.)	Fully-closed throttle: 0.5V Fully-open throttle: 4V
42	B	Sensor ground	—	—	—

TROUBLE DIAGNOSIS - GENERAL DESCRIPTION

Terminal No.	Wire color	Item	Condition	Judgement standard (Approx.)	
47	G	A/T fluid temperature sensor		When ATF temperature is 20°C (68°F).	1.5V
				When ATF temperature is 80°C (176°F).	0.5V
48	B	Ground	—	—	

*: These terminals are connected to the ECM.

** : These terminals are connected to the Data link connector.

CAN Communication

ECS006AS

CAN (Controller Area Network) is a serial communication line for real time application. It is an on-vehicle multiplex communication line with high data communication speed and excellent error detection ability. Many electronic control units are equipped onto a vehicle, and each control unit shares information and links with other control units during operation (not independent). In CAN communication, control units are connected with 2 communication lines (CAN H line, CAN L line) allowing a high rate of information transmission with less wiring. Each control unit transmits/receives data but selectively reads required data only.

FOR TCS MODELS

System diagram

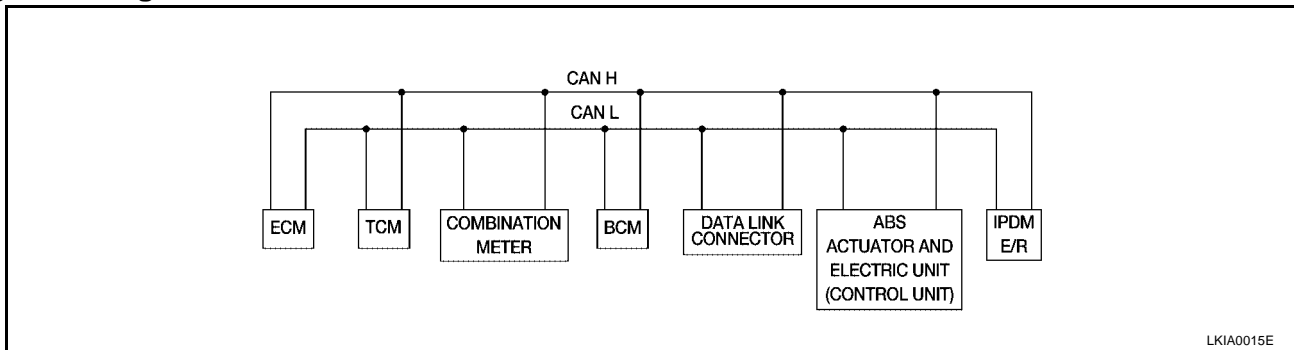

LKIA0015E

Input/output signal chart

T: Transmit R: Receive

Signals	ECM	TCM	COMBINATION METER	BCM	ABS/TCS control unit	IPDM E/R
Engine speed signal	T		R		R	
Engine coolant temperature signal	T		R			
Accelerator pedal position signal	T					
Fuel consumption monitor signal	T		R			
A/T warning lamp signal		T	R			
A/T position indicator signal	R		R	R (R range only)	R	
ABS operation signal	R				T	
TCS operation signal	R	R			T	
Air conditioner switch signal	R			T		
Air conditioner compressor signal	R					T
A/C compressor request signal	T					R
Cooling fan motor operation signal	R					T
Cooling fan speed request signal	T					R
Position lights request			R	T		R
Position lights status				R		T
Low beam request				T		R
Low beam status	R			R		T

TROUBLE DIAGNOSIS - GENERAL DESCRIPTION

Signals	ECM	TCM	COMBINATION METER	BCM	ABS/TCS control unit	IPDM E/R
High beam request			R	T		R
High beam status	R			R		T
Front fog lights request				T		R
Front fog light status				R		T
OD cancel switch signal		R	T			R
Brake switch signal		R	T			
Vehicle speed signal	R	T				
	R		T	R		
Oil pressure switch			R			T
Sleep request1			R	T		
Sleep request2				T		R
N range switch signal		R	T			
P range switch signal		R	T			
Seat belt buckle switch signal			T	R		
Door switch signal			R	T		R
Tail lamp request			R	T		R
Turn indicator signal			R	T		
Buzzer output signal			R	T		
Trunk switch signal			R	T		
ASCD main switch signal	T		R			
ASCD cruise signal	T		R			
Wiper operation				R		T
Wiper stop position signal				R		T
Rear window defogger switch signal				T		R
Rear window defogger control signal	R			R		T

FOR A/T MODELS

System diagram

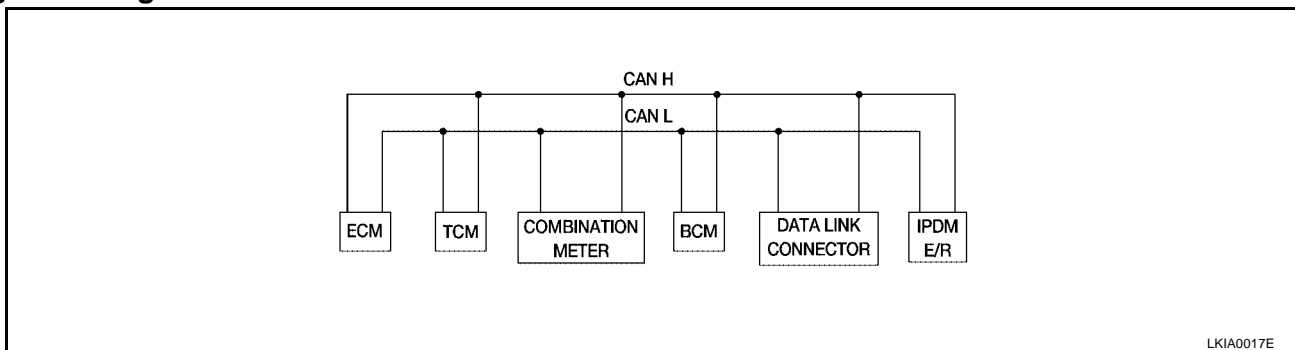

Input/output signal chart

T: Transmit R: Receive

Signals	ECM	TCM	COMBINATION METER	BCM	IPDM E/R
Engine speed signal	T		R		
Engine coolant temperature signal	T		R		
Accelerator pedal position signal	T				R

TROUBLE DIAGNOSIS - GENERAL DESCRIPTION

Signals	ECM	TCM	COMBINATION METER	BCM	IPDM E/R	
Fuel consumption monitor signal	T		R			A
A/T warning lamp signal		T	R			B
A/T position indicator signal	R	T	R	R(R range only)		B
Air conditioner switch signal	R			T		
Air conditioner compressor signal	R				T	AT
A/C compressor request signal	T				R	
Blower fan switch signal	R(QR25DE)			T		
Cooling fan motor operation signal	R			T		D
Cooling fan speed request signal	T				R	
Position lights request			R	T	R	E
Position lights status				R	T	
Low beam request				T	R	
Low beam status	R			R	T	F
High beam request			R	T	R	
High beam status	R			R	T	G
Front fog lights request				T	R	
Front fog light status				R	T	
OD cancel switch signal		R	T		R	H
Brake switch signal		R	T			
Vehicle speed signal	R	T				I
	R		T	R		
Oil pressure switch			R		T	
Sleep request1			R	T		J
Sleep request2				T	R	
N range switch signal		R	T			K
P range switch signal		R	T			
Seat belt buckle switch signal			T	R		
Door switch signal			R	T	R	L
Tail lamp request			R	T	R	
Turn indicator signal			R	T		M
Buzzer output signal			R	T		
Trunk switch signal			R	T		
ASCD main switch signal	T		R			
ASCD cruise signal	T		R			
Wiper operation				R	T	
Wiper stop position signal				R	T	
Rear window defogger switch signal				T	R	
Rear window defogger control signal	R			R	T	

TROUBLE DIAGNOSIS - GENERAL DESCRIPTION

FOR M/T MODELS

System diagram

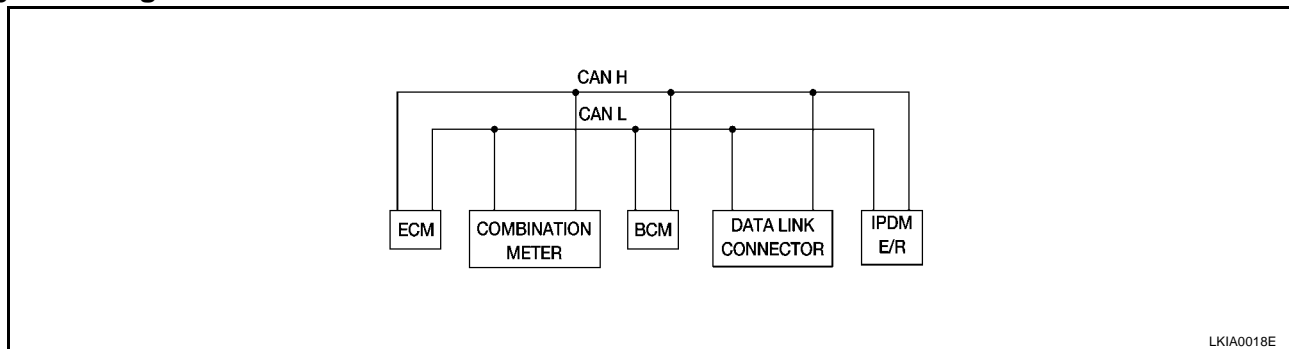

LKIA0018E

Input/output signal chart

T: Transmit R: Receive

Signals	ECM	COMBINATION METER	BCM	IPDM E/R
Engine speed signal	T			
Engine coolant temperature signal	T			
Fuel consumption monitor signal	T			
Air conditioner switch signal	R		T	
Air conditioner compressor signal	R			T
A/C compressor request signal	T			R
Blower fan switch signal	R(QR25DE)		T	
Cooling fan motor operation signal	R			T
Cooling fan speed request signal	T			R
Position lights request		R	T	R
Position lights status			R	T
Low beam request			T	R
Low beam status	R		R	T
High beam request		R	T	R
High beam status	R		R	T
Front fog lights request			T	R
Front fog light status			R	T
Vehicle speed signal	R	T		
Oil pressure switch		R		T
Sleep request1		R	T	
Sleep request2			T	R
Seat belt buckle switch signal		T	R	
Door switch signal		R	T	R
Tail lamp request		R	T	R
Turn indicator signal		R	T	
Buzzer output signal		R	T	
Trunk switch signal		R	T	
ASCD main switch signal	T	R		
ASCD cruise signal	T	R		
Wiper operation			R	T
Wiper stop position signal			R	T

TROUBLE DIAGNOSIS - GENERAL DESCRIPTION

Signals	ECM	COMBINATION METER	BCM	IPDM E/R
Rear window defogger switch signal			T	R
Rear window defogger control signal	R		R	T

A

B

AT

D

E

F

G

H

I

J

K

L

M

TROUBLE DIAGNOSIS FOR POWER SUPPLY

TROUBLE DIAGNOSIS FOR POWER SUPPLY

PF0:0000

Wiring Diagram — AT — MAIN

ECS006AT

AT-MAIN-01

: DETECTABLE LINE FOR DTC
 : NON-DETECTABLE LINE FOR DTC

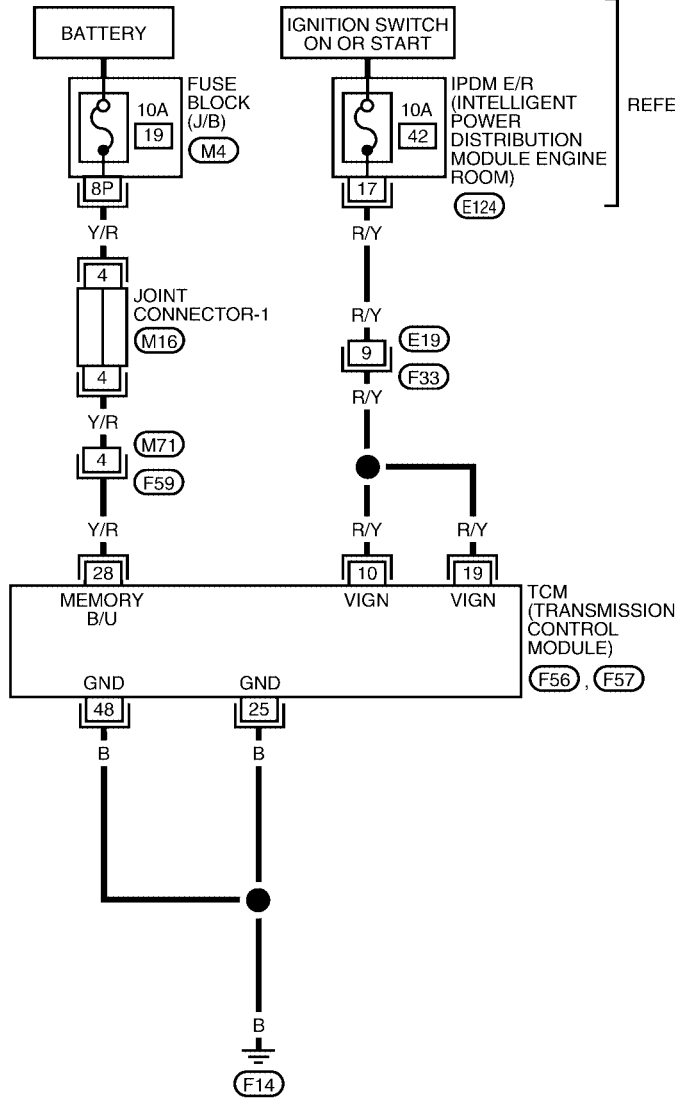

REFER TO "PG-POWER".

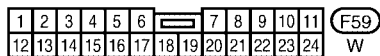
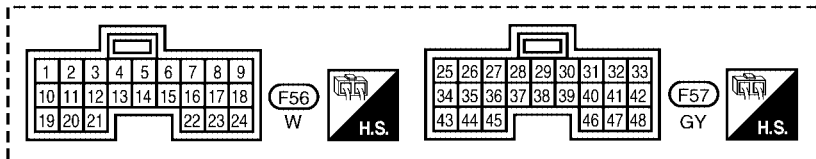
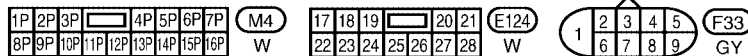

REFER TO THE FOLLOWING.

(M16) - JOINT CONNECTOR (JC)

WCWA0045E

TROUBLE DIAGNOSIS FOR POWER SUPPLY

TCM TERMINALS AND REFERENCE VALUE MEASURED BETWEEN EACH TERMINAL AND 25 OR 48 (TCM GROUND)

TERMINAL	WIRE COLOR	ITEM	CONDITION	DATA (APPROX.)
10	R/Y	POWER SOURCE	IGNITION ON	BATTERY VOLTAGE
			IGNITION OFF	0V
19	R/Y	POWER SOURCE	IGNITION ON	BATTERY VOLTAGE
			IGNITION OFF	0V
25	B	GROUND	—	—
28	Y/R	POWER SOURCE (MEMORY BACKUP)	IGNITION ON	BATTERY VOLTAGE
			IGNITION OFF	BATTERY VOLTAGE
48	B	GROUND	—	—

Diagnostic Procedure

ECS006AU

1. CHECK TCM POWER SOURCE STEP 1

- Turn ignition switch to ON position.
(Do not start engine.)
- Check voltage between TCM terminals 10, 19, 28 and ground.

Voltage : **Battery voltage**

OK or NG

- OK >> GO TO 2.
NG >> GO TO 3.

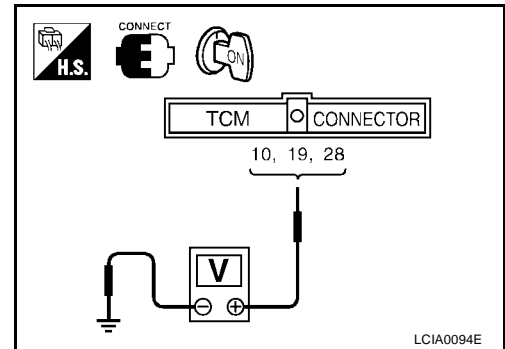

2. CHECK TCM POWER SOURCE STEP 2

- Turn ignition switch to OFF position.
- Check voltage between TCM terminal 28 (Y/R) and ground.

Voltage : **Battery voltage**

OK or NG

- OK >> GO TO 4.
NG >> GO TO 3.

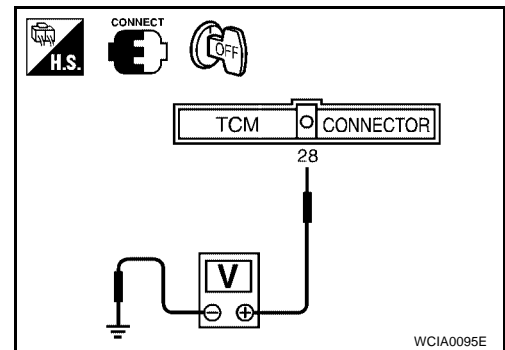

3. DETECT MALFUNCTIONING ITEM

Check the following items:

- Harness for short or open between ignition switch and TCM terminals 10, 19 and 28 (Main harness)
- Fuse
- Ignition switch
Refer to [PG-3, "POWER SUPPLY ROUTING CIRCUIT"](#).

OK or NG

- OK >> GO TO 4.
NG >> Repair or replace damaged parts.

TROUBLE DIAGNOSIS FOR POWER SUPPLY

4. CHECK TCM GROUND CIRCUIT

1. Turn ignition switch to OFF position.
2. Disconnect TCM harness connector.
3. Check continuity between TCM terminals 25, 48 and ground. Refer to [AT-100, "Wiring Diagram — AT — MAIN"](#).

Continuity should exist.

OK or NG

OK >> **INSPECTION END**

NG >> Repair open circuit or short to ground or short to power in harness or connectors.

DTC P0705 PARK/NEUTRAL POSITION SWITCH

DTC P0705 PARK/NEUTRAL POSITION SWITCH

PF03:32006

Description

ECS006AV

- The park/neutral position (PNP) switch includes a transmission range switch.
- The transmission range switch detects the selector lever position and sends a signal to the TCM.

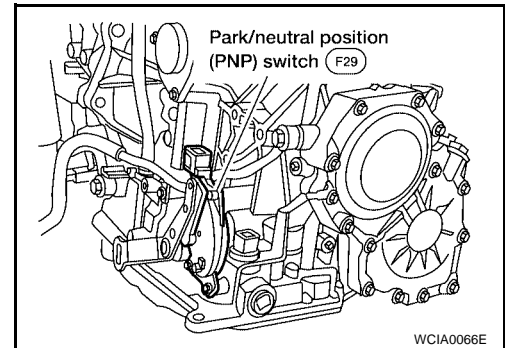

On Board Diagnosis Logic

ECS006AW

Diagnostic trouble code PNP SW/CIRC with CONSULT-II or P0705 without CONSULT-II is detected when TCM does not receive the correct voltage signal from the switch based on the gear position.

Possible Cause

ECS006AX

Check the following items.

- Harness or connectors
(The park/neutral position (PNP) switch circuit is open or shorted.)
- Park/neutral position (PNP) switch

Diagnostic Trouble Code (DTC) Confirmation Procedure

ECS006AY

CAUTION:

Always drive vehicle at a safe speed.

NOTE:

If "DTC Confirmation Procedure" has been previously conducted, always turn ignition switch OFF and wait at least 10 seconds before conducting the next test.

After the repair, perform the following procedure to confirm the malfunction is eliminated.

WITH CONSULT-II

1. Turn ignition switch ON.

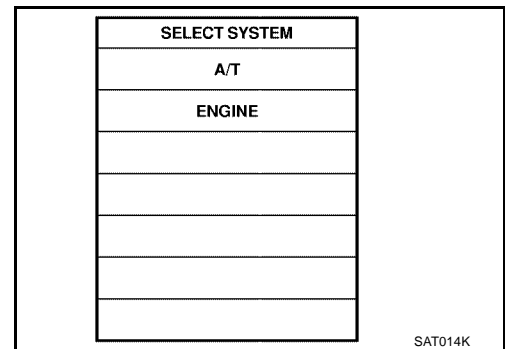

2. Select "DATA MONITOR" mode for "ENGINE" with CONSULT-II.
3. Start engine and maintain the following conditions for at least 5 consecutive seconds.

VHCL SPEED SE: 10 km/h (6 MPH) or more

THRTL POS SEN: More than 1.3V

Selector lever: 3 or D position

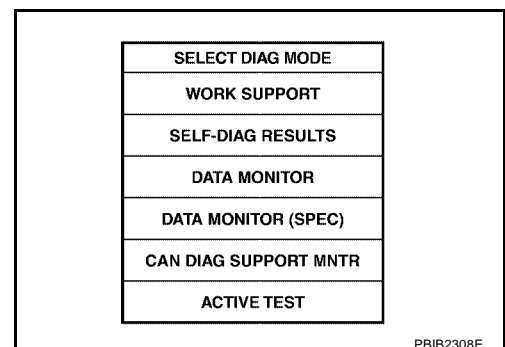

DTC P0705 PARK/NEUTRAL POSITION SWITCH

WITH GST

Follow the procedure "With CONSULT-II".

DTC P0705 PARK/NEUTRAL POSITION SWITCH

ECS006AZ

Wiring Diagram — AT — PNP/SW

AT-PNP/SW-01

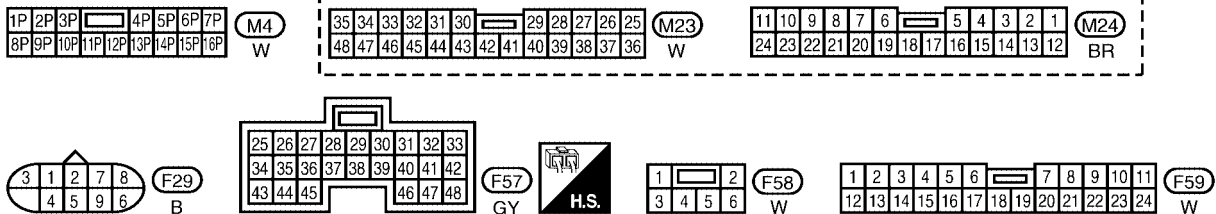
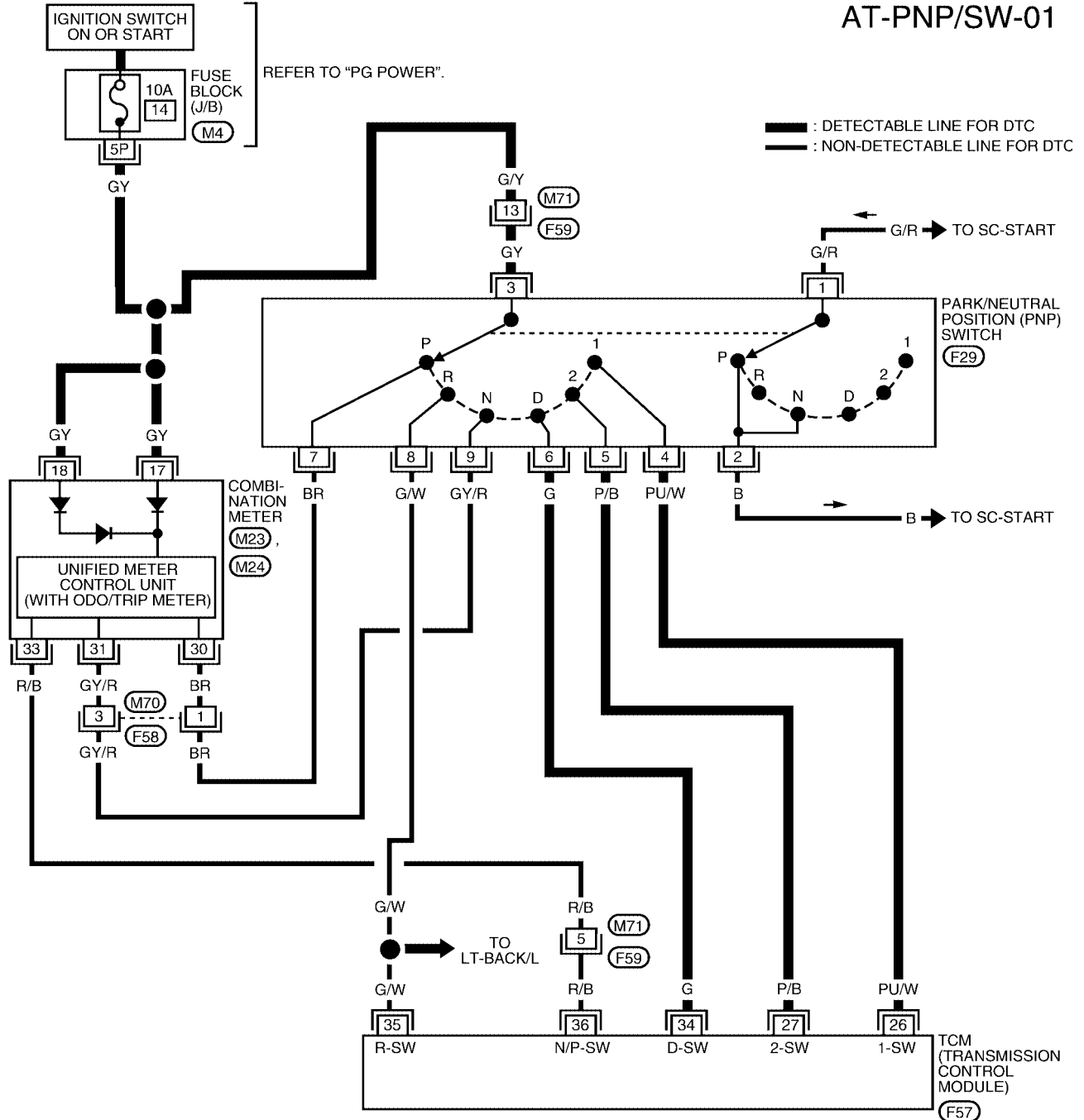

WCWA0046E

DTC P0705 PARK/NEUTRAL POSITION SWITCH

TCM TERMINALS AND REFERENCE VALUE MEASURED BETWEEN EACH TERMINAL AND 25 OR 48 (TCM GROUND)

TERMINAL	WIRE COLOR	ITEM	CONDITION	DATA (APPROX.)
26	PU/W	PNP SWITCH 1 POSITION	WHEN SETTING SELECTOR LEVER IN 1 POSITION	BATTERY VOLTAGE
			WHEN SETTING SELECTOR LEVER IN OTHER POSITIONS	0V
27	P/B	PNP SWITCH 2 POSITION	WHEN SETTING SELECTOR LEVER IN 2 POSITION	BATTERY VOLTAGE
			WHEN SETTING SELECTOR LEVER IN OTHER POSITIONS	0V
34	G	PNP SWITCH D POSITION	WHEN SETTING SELECTOR LEVER IN D POSITION	BATTERY VOLTAGE
			WHEN SETTING SELECTOR LEVER IN OTHER POSITIONS	0V
35	G/W	PNP SWITCH R POSITION	WHEN SETTING SELECTOR LEVER IN R POSITION	BATTERY VOLTAGE
			WHEN SETTING SELECTOR LEVER IN OTHER POSITIONS	0V
36	R/B	PNP SWITCH P OR N POSITION	WHEN SETTING SELECTOR LEVER IN P OR N POSITION	BATTERY VOLTAGE
			WHEN SETTING SELECTOR LEVER IN OTHER POSITIONS	0V

Diagnostic Procedure

ECS006B0

1. INSPECTION START

Do you have CONSULT-II?

Yes or No

- Yes >> GO TO 2.
- No >> GO TO 6.

2. CHECK PARK/NEUTRAL POSITION (PNP) SWITCH CIRCUIT (WITH CONSULT-II)

With CONSULT-II

1. Turn ignition switch to ON position.
(Do not start engine.)
2. Select "TCM INPUT SIGNALS" in "DATA MONITOR" mode for "A/T" with CONSULT-II.
3. Read out P, R, N, D, 2 and 1 position switches moving selector lever to each position.
Check that the signal of the selector lever position is indicated properly.

OK or NG

- OK >> GO TO 7.
- NG >> GO TO 3.

DATA MONITOR	
MONITORING	
PN POSI SW	OFF
R POSITION SW	OFF
D POSITION SW	OFF
2 POSITION SW	ON
1 POSITION SW	OFF

SAT701J

DTC P0705 PARK/NEUTRAL POSITION SWITCH

3. DETECT MALFUNCTIONING ITEM

Check the following item:

- Park/neutral position (PNP) switch
Check continuity between park/neutral position (PNP) switch F29 terminals 1 (G/R) and 2 (B) and between terminals 3 (G/Y) and 4 (PU/W), 5 (P/B), 6 (G), 7 (BR), 8 (G/W) and 9 (GY/R) while moving manual shaft through each position.

Lever position	Terminal No.	
P	3 - 7	1 - 2
R	3 - 8	
N	3 - 9	1 - 2
D	3 - 6	
2	3 - 5	
1	3 - 4	

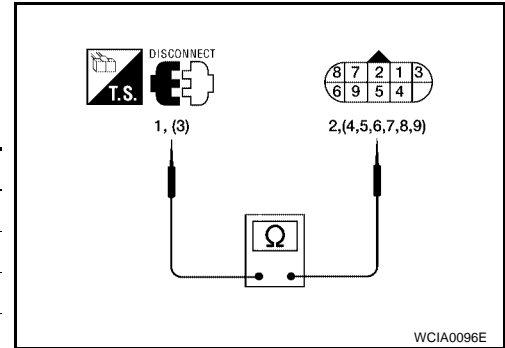

OK or NG

- OK >> GO TO 5.
- NG >> GO TO 4.

4. CHECK MANUAL CONTROL CABLE ADJUSTMENT

Check PNP switch again with manual control cable disconnected from manual shaft of A/T assembly. Refer to test group 1.

OK or NG

- OK >> Adjust manual control cable. Refer to [AT-267, "Control Cable Adjustment"](#).
- NG >> Repair or replace PNP switch.

5. DETECT MALFUNCTIONING ITEM

Check the following items:

- Harness for short or open between ignition switch and park/neutral position (PNP) switch (Main harness)
- Harness for short or open between park/neutral position (PNP) switch and TCM (Main harness)
- Fuse
- Joint connector-3 M29
- Ignition switch
Refer to [PG-3, "POWER SUPPLY ROUTING CIRCUIT"](#).

OK or NG

- OK >> GO TO 7.
- NG >> Repair or replace damaged parts.

DTC P0705 PARK/NEUTRAL POSITION SWITCH

6. CHECK PARK/NEUTRAL POSITION (PNP) SWITCH CIRCUIT (WITHOUT CONSULT-II)

⊗ Without CONSULT-II

1. Turn ignition switch to ON position. (Do not start engine.)
2. Check voltage between TCM terminals 26 (PU/W), 27 (P/B), 34 (G), 35 (G/W), 36 (R/B) and ground while moving selector lever through each position.

Lever Position	Terminal No.				
	36	35	34	27	26
P, N	B	0	0	0	0
R	0	B	0	0	0
D	0	0	B	0	0
2	0	0	0	B	0
1	0	0	0	0	B

B = Battery voltage

0 = 0V

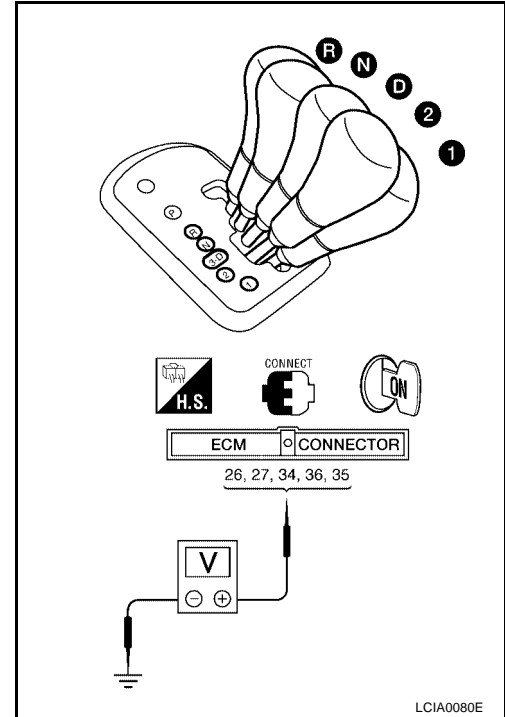

OK or NG

- OK >> GO TO 7.
 NG >> GO TO 5.

7. CHECK DTC

Perform [AT-103. "Diagnostic Trouble Code \(DTC\) Confirmation Procedure"](#) .

OK or NG

- OK >> **INSPECTION END**
 NG >> GO TO 8.

8. CHECK TCM INSPECTION

1. Perform TCM input/output signal inspection.
2. If NG, recheck TCM pin terminals for damage or loose connection with harness connector.

OK or NG

- OK >> **INSPECTION END**
 NG >> Repair or replace damaged parts.

DTC P0710 A/T FLUID TEMPERATURE SENSOR CIRCUIT

DTC P0710 A/T FLUID TEMPERATURE SENSOR CIRCUIT

PF3:31940

Description

ECS006B1

The A/T fluid temperature sensor detects the A/T fluid temperature and sends a signal to the TCM.

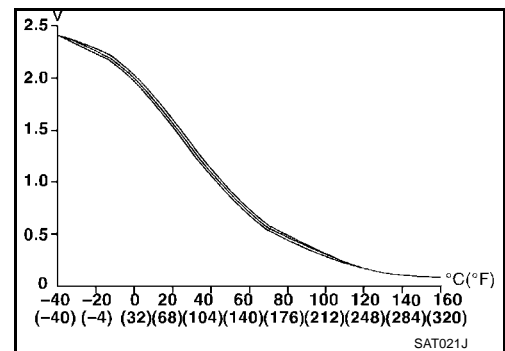
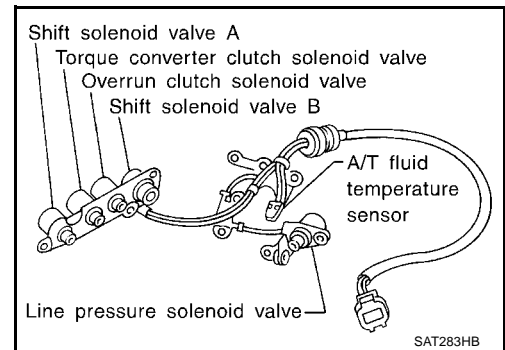

CONSULT-II REFERENCE VALUE IN DATA MONITOR MODE

Remarks: Specification data are reference values.

Monitor item	Condition	Specification (Approximately)	
A/T fluid temperature sensor	Cold [20°C (68°F)]	1.5V	2.5 kΩ
	↓ Hot [80°C (176°F)]	0.5V	0.3 kΩ

On Board Diagnosis Logic

ECS006B2

Diagnostic trouble code ATF TEMP SEN/CIRC with CONSULT-II or P0710 without CONSULT-II is detected when TCM receives an excessively low or high voltage from the sensor.

Possible Cause

ECS006B3

Check the following items.

- Harness or connectors
(The sensor circuit is open or shorted.)
- A/T fluid temperature sensor

Diagnostic Trouble Code (DTC) Confirmation Procedure

ECS006B4

CAUTION:

Always drive vehicle at a safe speed.

NOTE:

If "DTC Confirmation Procedure" has been previously conducted, always turn ignition switch OFF and wait at least 10 seconds before conducting the next test.

After the repair, perform the following procedure to confirm the malfunction is eliminated.

DTC P0710 A/T FLUID TEMPERATURE SENSOR CIRCUIT

WITH CONSULT-II

1. Turn ignition switch ON and select "DATA MONITOR" mode for "ENGINE" with CONSULT-II.

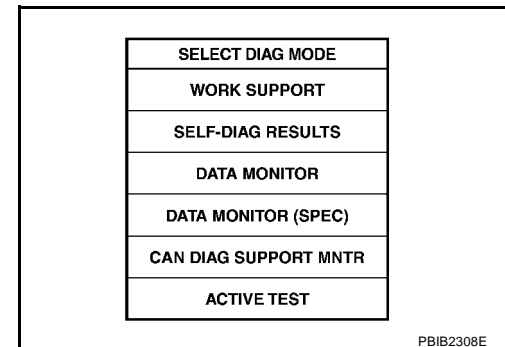
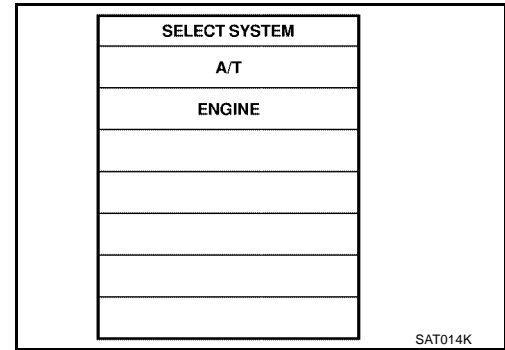

2. Select "ECM INPUT SIGNALS" touch "START".
3. Start engine and maintain the following conditions for at least 10 minutes (Total). (It is not necessary to maintain continuously.)
 - ENG SPEED: 450 rpm or more**
 - VEHICLE SPEED: 10 km/h (6 MPH) or more**
 - THRTL POSI: More than 1.2V**
 - Selector lever: D position**

WITH GST

Follow the procedure "With CONSULT-II".

DTC P0710 A/T FLUID TEMPERATURE SENSOR CIRCUIT

Wiring Diagram — AT — FTS

ECS006B5

AT-FTS-01

: DETECTABLE LINE FOR DTC
 : NON-DETECTABLE LINE FOR DTC

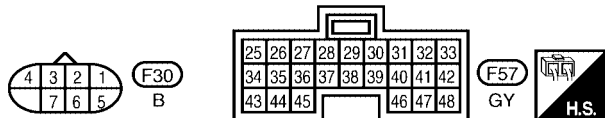
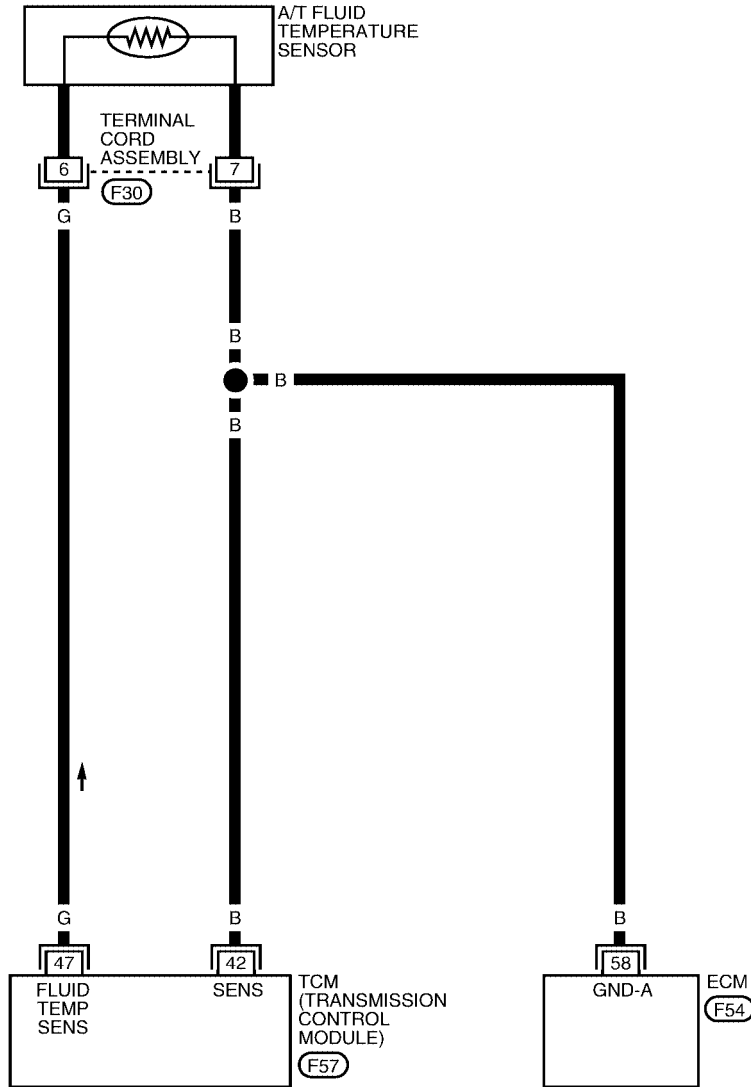

REFER TO THE FOLLOWING.
 (F54) - ELECTRICAL UNITS

WCWA0047E

DTC P0710 A/T FLUID TEMPERATURE SENSOR CIRCUIT

TCM TERMINALS AND REFERENCE VALUE MEASURED BETWEEN EACH TERMINAL AND 25 OR 48 (TCM GROUND)				
TERMINAL	WIRE COLOR	ITEM	CONDITION	DATA (APPROX.)
42	B	SENSOR GROUND	—	—
47	G	A/T FLUID TEMPERATURE SENSOR	IGNITION ON AND ATF TEMPERATURE IS 20°C (68°F)	1.5V
			IGNITION ON AND ATF TEMPERATURE IS 80°C (176°F)	0.5V

DTC P0710 A/T FLUID TEMPERATURE SENSOR CIRCUIT

ECS006B6

Diagnostic Procedure

1. INSPECTION START

Do you have CONSULT-II?

Yes or No

- Yes >> GO TO 2.
- No >> GO TO 6.

2. CHECK INPUT SIGNAL OF A/T FLUID TEMPERATURE SENSOR (WITH CONSULT-II)

 With CONSULT-II

1. Start engine.
2. Select "TCM INPUT SIGNALS" in "DATA MONITOR" mode for "A/T" with CONSULT-II.
3. Read out the value of "FLUID TEMP SE".

Voltage :Cold [20°C (68°F)] → Hot [80°C (176°F)]
:Approximately 1.5V → 0.5V

OK or NG

- OK >> GO TO 7.
- NG >> GO TO 3.

DATA MONITOR	
MONITORING	
VHCL/S SE-A/T	XXX km/h
VHCL/S SE-MTR	XXX km/h
THRTL POS SEN	XXX V
FLUID TEMP SE	XXX V
BATTERY VOLT	XXX V

LCIA0090E

3. CHECK A/T FLUID TEMPERATURE SENSOR WITH TERMINAL CORD ASSEMBLY

1. Turn ignition switch to OFF position.
2. Disconnect terminal cord assembly connector in engine compartment.
3. Check resistance between terminal cord F30 terminals 6 and 7 (component side) when A/T is cold.

Temperature	Resistance (Approx.)
Cold [20°C (68°F)]	2.5kΩ

4. Reinstall any part removed.

OK or NG

- OK >> GO TO 4.
- NG >> GO TO 5.

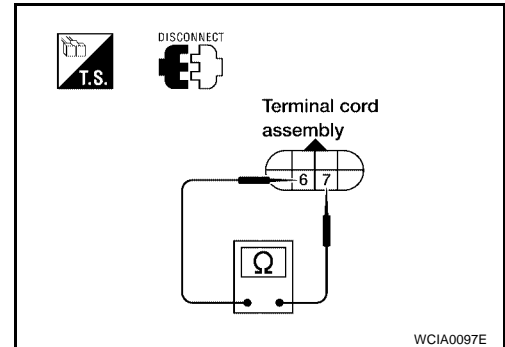

4. DETECT MALFUNCTIONING ITEM

Check the following items:

- Harness for short to ground or short to power or open between TCM, ECM and terminal cord assembly (Main harness)
- Ground circuit for ECM
Refer to [PG-3. "POWER SUPPLY ROUTING CIRCUIT"](#).

OK or NG

- OK >> GO TO 7.
- NG >> Repair or replace damaged parts.

DTC P0710 A/T FLUID TEMPERATURE SENSOR CIRCUIT

5. DETECT MALFUNCTIONING ITEM

1. Remove oil pan.
2. Check the following items:
 - A/T fluid temperature sensor
Check resistance between two terminals while changing temperature as shown in figure.

Temperature	Resistance (Approx.)
20 (68)	25k Ω
80 (176)	0.3k Ω

- Harness of terminal cord assembly for short or open

OK or NG

- OK >> GO TO 7.
- NG >> Repair or replace damaged parts.

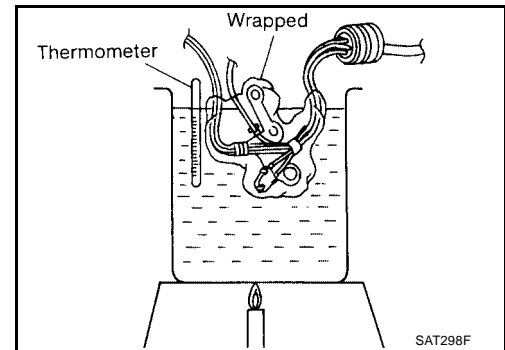

6. CHECK INPUT SIGNAL OF A/T FLUID TEMPERATURE SENSOR (WITHOUT CONSULT-II)

⊗ Without CONSULT-II

1. Start engine.
2. Check voltage between TCM terminal 47 (G) and ground while warming up A/T.

Temperature	Voltage (Approx.)
Cold [20°C (68°F)] → Hot [80°C (176°F)]	1.5V → 0.5V

OK or NG

- OK >> GO TO 7.
- NG >> GO TO 3.

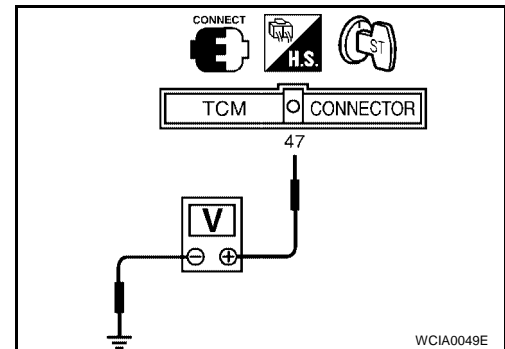

7. CHECK DTC

Perform [AT-109, "Diagnostic Trouble Code \(DTC\) Confirmation Procedure"](#) .

OK or NG

- OK >> **INSPECTION END**
- NG >> GO TO 8.

8. CHECK TCM INSPECTION

1. Perform TCM input/output signal inspection.
2. If NG, recheck TCM pin terminals for damage or loose connection with harness connector.

OK or NG

- OK >> **INSPECTION END**
- NG >> Repair or replace damaged parts.

DTC P0720 VEHICLE SPEED SENSOR-A/T (REVOLUTION SENSOR)

DTC P0720 VEHICLE SPEED SENSOR-A/T (REVOLUTION SENSOR)

PF:32702

Description

ECS006B7

The revolution sensor detects the revolution of the idler gear parking pawl lock gear and emits a pulse signal. The pulse signal is sent to the TCM which converts it into vehicle speed.

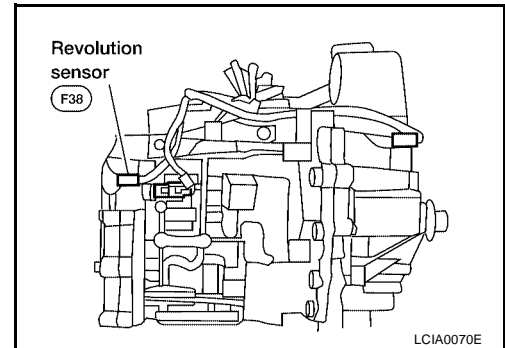

On Board Diagnosis Logic

ECS006B8

Diagnostic trouble code VEH SPD SEN/CIR AT with CONSULT-II or P0720 without CONSULT-II is detected when TCM does not receive the proper voltage signal from the sensor.

Possible Cause

ECS006B9

Check the following items.

- Harness or connectors
(The sensor circuit is open or shorted.)
- Revolution sensor

Diagnostic Trouble Code (DTC) Confirmation Procedure

ECS006BA

CAUTION:

- Always drive vehicle at a safe speed.
- Be careful not to rev engine into the red zone on the tachometer.

NOTE:

If "DTC Confirmation Procedure" has been previously conducted, always turn ignition switch OFF and wait at least 10 seconds before conducting the next test.

After the repair, perform the following procedure to confirm the malfunction is eliminated.

WITH CONSULT-II

1. Turn ignition switch ON and select "DATA MONITOR" mode for "A/T" with CONSULT-II.

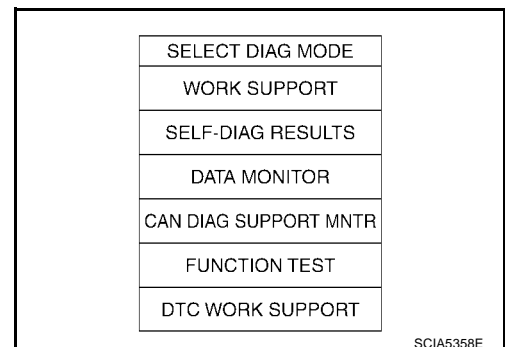
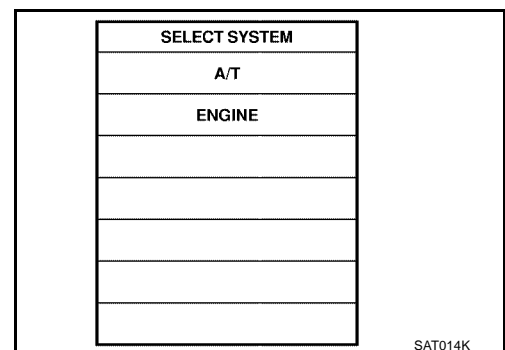

DTC P0720 VEHICLE SPEED SENSOR-A/T (REVOLUTION SENSOR)

2. Drive vehicle and check for an increase of "VHCL/S SE-MTR" value.
If the check result is NG, go to [AT-118, "Diagnostic Procedure"](#).
If the check result is OK, go to following step.
3. Select "DATA MONITOR" mode for "ENGINE" with CONSULT-II.

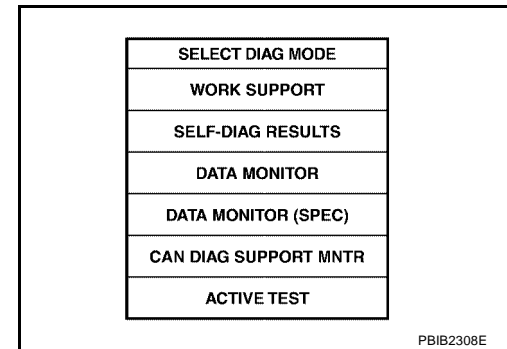
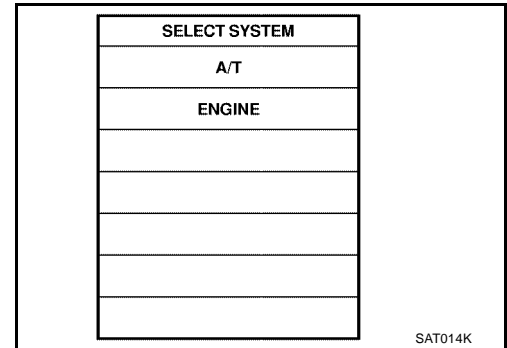

4. Start engine and maintain the following conditions for at least 5 consecutive seconds.
VHCL SPEED SE: 30 km/h (19 MPH) or more
THRTL POS SEN: More than 1.2V
Selector lever: D position
Driving location: Driving the vehicle uphill (increased engine load) will help maintain the driving conditions required for this test.
If the check result is NG, go to [AT-118, "Diagnostic Procedure"](#).
If the check result is OK, go to following step.
5. Maintain the following conditions for at least 5 consecutive seconds.
CMPS-RPM (REF): 3,500 rpm or more
THRTL POS SEN: More than 1.2V
Selector lever: D position
Driving location: Driving the vehicle uphill (increased engine load) will help maintain the driving conditions required for this test.

WITH GST

Follow the procedure "With CONSULT-II".

DTC P0720 VEHICLE SPEED SENSOR-A/T (REVOLUTION SENSOR)

Wiring Diagram — AT — VSSA/T

ECS006BB

AT-VSSA/T-01

— : DETECTABLE LINE FOR DTC
— : NON-DETECTABLE LINE FOR DTC

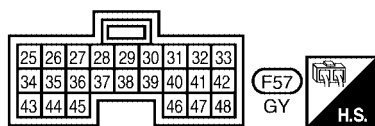
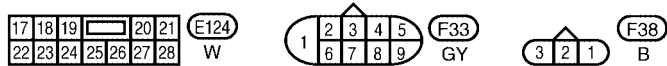
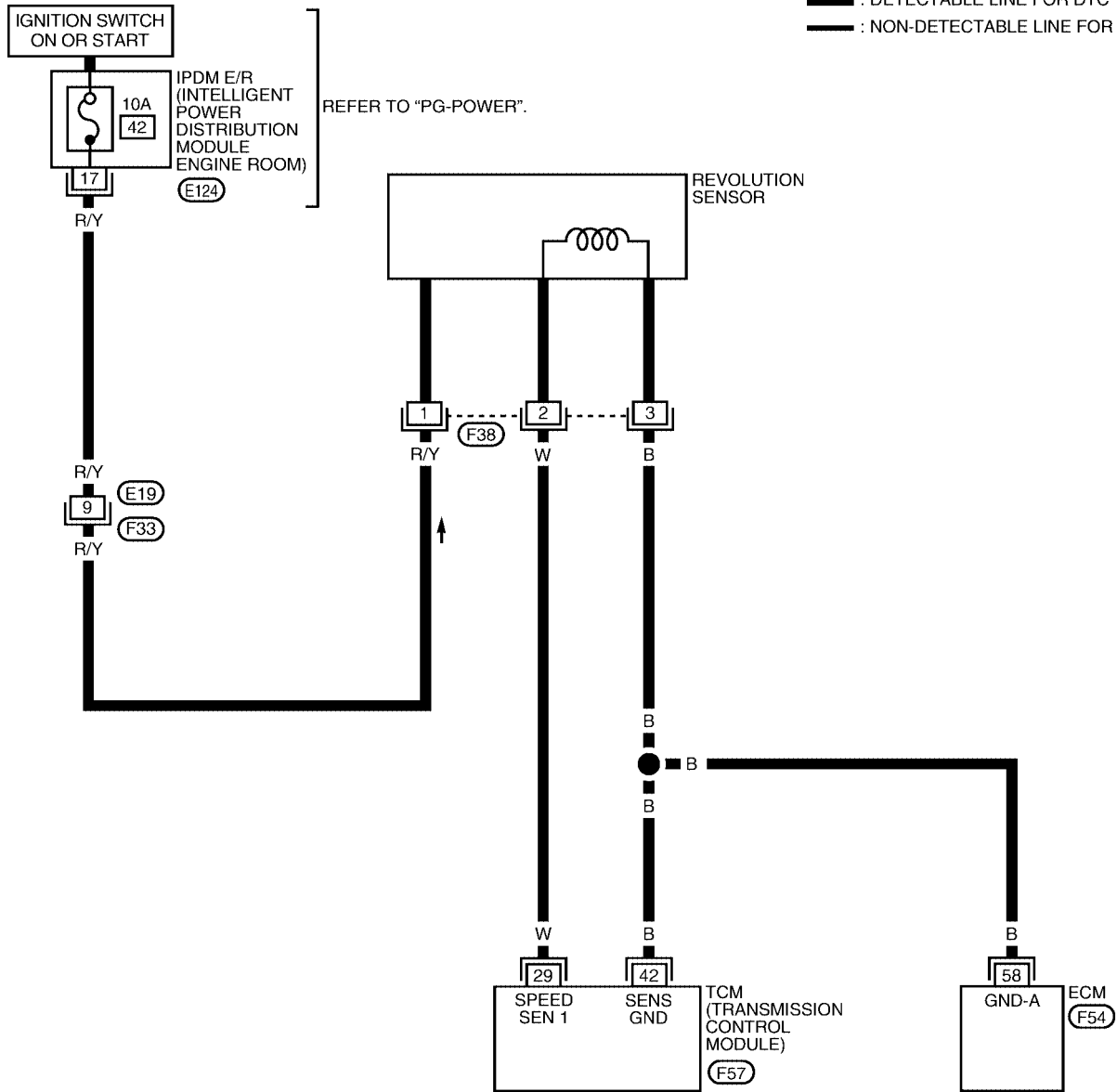

REFER TO THE FOLLOWING.
(F54) - ELECTRICAL UNITS

WCWA0048E

DTC P0720 VEHICLE SPEED SENSOR-A/T (REVOLUTION SENSOR)

TERMINALS AND REFERENCE VALUE MEASURED BETWEEN EACH TERMINAL

TERMINAL	WIRE COLOR	ITEM	CONDITION	DATA (DC)
29	W	REVOLUTION SENSOR	VEHICLE MOVING AT 20 KM/H (12 MPH). USE THE CONSULT-II PULSE FREQUENCY MEASURING FUNCTION. A CIRCUIT TESTER CANNOT BE USED TO TEST THIS ITEM. CAUTION: CONNECT THE DIAGNOSIS DATA LINK CABLE TO THE VEHICLE DIAGNOSIS CONNECTOR.	450 HZ
			VEHICLE NOT MOVING.	LESS THAN 1.3V OR GREATER THAN 4.5V
42	B	SENSOR GROUND	—	—

Diagnostic Procedure

ECS006BC

1. CHECK INPUT SIGNAL (WITH CONSULT-II)

With CONSULT-II

1. Start engine.
2. Select "TCM INPUT SIGNALS" in "DATA MONITOR" mode for "A/T" with CONSULT-II.
3. Read out the value of "VHCL/S SE-A/T" while driving.
Check the value changes according to driving speed.

OK or NG

- OK >> GO TO 3.
NG >> GO TO 2.

DATA MONITOR	
MONITORING	
VHCL/S SE-A/T	XXX km/h
VHCL/S SE-MTR	XXX km/h
THRTL POS SEN	XXX V
FLUID TEMP SE	XXX V
BATTERY VOLT	XXX V

LCIA0090E

2. CHECK REVOLUTION SENSOR (WITH CONSULT-II)

With CONSULT-II

1. Start engine.
- Harness for short or open between TCM, ECM and revolution sensor (Main harness)

OK or NG

- OK >> GO TO 3.
NG >> Repair or replace damaged parts.

Condition	Judgement standard (Approx.)
When moving at 20 km/h (12 MPH), use the CONSULT-II pulse frequency measuring function. *1 CAUTION: Connect the diagnosis data link cable to the vehicle diagnosis connector. *1: A circuit tester cannot be used to test this item.	450 Hz
When vehicle parks.	0V

LCIA0091E

3. CHECK DTC

Perform [AT-115. "Diagnostic Trouble Code \(DTC\) Confirmation Procedure"](#) .

OK or NG

- OK >> **INSPECTION END**
NG >> GO TO 4.

DTC P0720 VEHICLE SPEED SENSOR-A/T (REVOLUTION SENSOR)

4. CHECK TCM INSPECTION

1. Perform TCM input/output signal inspection.
2. If NG, recheck TCM pin terminals for damage or loose connection with harness connector.

OK or NG

- OK >> **INSPECTION END**
NG >> Repair or replace damaged parts.

A

B

AT

D

E

F

G

H

I

J

K

L

M

DTC P0725 ENGINE SPEED SIGNAL

DTC P0725 ENGINE SPEED SIGNAL

PF2:24825

Description

ECS006BD

The engine speed signal is sent from the ECM to the TCM.

On Board Diagnosis Logic

ECS006BE

Diagnostic trouble code ENGINE SPEED SIG with CONSULT-II or P0725 without CONSULT-II is detected when TCM does not receive the proper voltage signal from ECM.

Possible Cause

ECS006BF

Check harness or connectors. (The sensor circuit is open or shorted.)

Diagnostic Trouble Code (DTC) Confirmation Procedure

ECS006BG

CAUTION:

Always drive vehicle at a safe speed.

NOTE:

If "DTC Confirmation Procedure" has been previously conducted, always turn ignition switch OFF and wait at least 10 seconds before conducting the next test.

After the repair, perform the following procedure to confirm the malfunction is eliminated.

WITH CONSULT-II

1. Turn ignition switch ON and select "DATA MONITOR" mode for "ENGINE" with CONSULT-II.

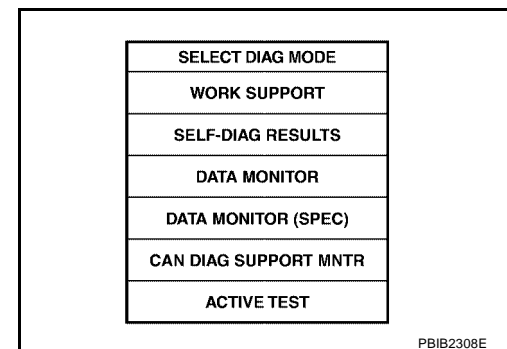
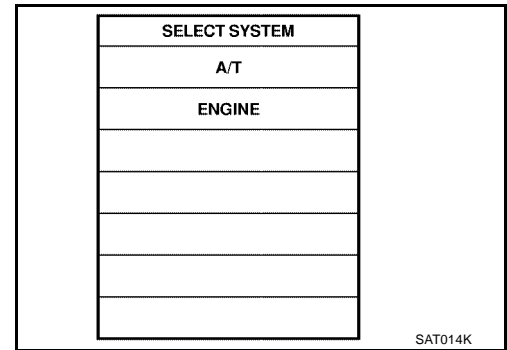

2. Start engine and maintain the following conditions for at least 10 consecutive seconds.

VHCL SPEED SE: 10 km/h (6 MPH) or more

THRTL POS SEN: More than 1.2V

Selector lever: D position

WITH GST

Follow the procedure "With CONSULT-II".

DTC P0725 ENGINE SPEED SIGNAL

Wiring Diagram — AT — ENGSS

ECS006BH

AT-ENGSS-01

A
B
AT
D
E
F
G
H
I
J
K
L
M

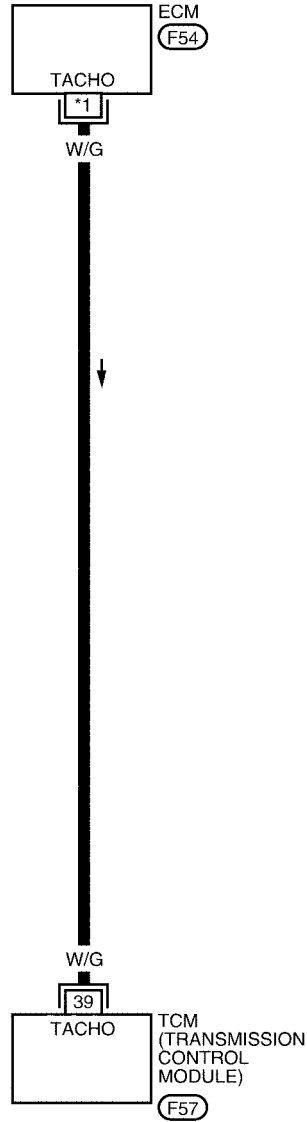

- : DETECTABLE LINE FOR DTC
- : NON-DETECTABLE LINE FOR DTC
- : WITH QR25DE
- : WITH VQ35DE
- : 36
- : 34

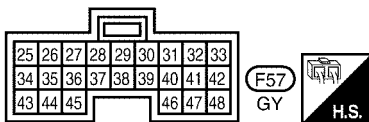

REFER TO THE FOLLOWING.
F54 - ELECTRICAL UNITS

WCWA0049E

DTC P0725 ENGINE SPEED SIGNAL

TCM TERMINALS AND REFERENCE VALUE MEASURED BETWEEN EACH TERMINAL AND 25 OR 48 (TCM GROUND)

TERMINAL	WIRE COLOR	ITEM	CONDITION	DATA
39	W/G	ENGINE SPEED SIGNAL	EC-99, "ECM INSPECTION TABLE" (with QR25DE), or EC-727, "ECM INSPECTION TABLE" (with VQ35DE)	

Diagnostic Procedure

ECS006BI

1. CHECK DTC WITH ECM

- Check P code.
Turn ignition switch ON and select "SELF-DIAGNOSTIC RESULTS" mode for "ENGINE" with CONSULT-II.
Refer to [EC-68, "Malfunction Indicator Lamp \(MIL\)"](#) (with QR25DE), or [EC-693, "Malfunction Indicator Lamp \(MIL\)"](#) (with VQ35DE).

OK or NG

OK (with CONSULT-II)>> GO TO 2.

OK (without CONSULT-II)>> GO TO 4.

NG >> Check ignition signal circuit for engine control. Refer to [EC-559, "IGNITION SIGNAL"](#) (with QR25DE), or [EC-1235, "IGNITION SIGNAL"](#) (with VQ35DE).

2. CHECK INPUT SIGNAL (WITH CONSULT-II)

Ⓜ With CONSULT-II

- Start engine.
- Select "TCM INPUT SIGNALS" in "DATA MONITOR" mode for "A/T" with CONSULT-II.
- Read out the value of "ENGINE SPEED".
Check engine speed changes according to throttle position.

OK or NG

OK >> GO TO 6.

NG >> GO TO 3.

DATA MONITOR	
MONITORING	
ENGINE SPEED	XXX rpm
TURBINE REV	XXX rpm
OVERDRIVE SW	ON
PN POSI SW	OFF
R POSITION SW	OFF

SAT645J

3. DETECT MALFUNCTIONING ITEM

Check the following items:

- Harness for short or open between TCM and ECM
- Resistor and ignition coil
Refer to [EC-559, "IGNITION SIGNAL"](#) (with QR25DE), or [EC-1235, "IGNITION SIGNAL"](#) (with VQ35DE).

OK or NG

OK >> GO TO 6.

NG >> Repair or replace damaged parts.

DTC P0725 ENGINE SPEED SIGNAL

4. CHECK INPUT SIGNAL (WITHOUT CONSULT-II)

⊗ Without CONSULT-II

1. Start engine.
2. Check voltage between TCM terminal 39 (W/G) and ground.

Voltage :0.6 (Idle speed) - 2.2V (3,000 rpm)

OK or NG

- OK >> GO TO 6.
- NG >> GO TO 5.

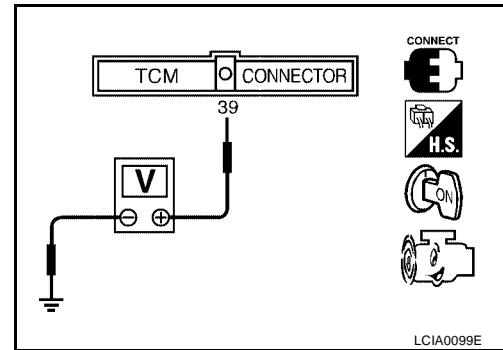

5. DETECT MALFUNCTIONING ITEM

Check the following items:

- Harness for short or open between TCM and ECM
- Resistor and ignition coil
Refer to [EC-559, "IGNITION SIGNAL"](#) (with QR25DE), or [EC-1235, "IGNITION SIGNAL"](#) (with VQ35DE).

OK or NG

- OK >> GO TO 6.
- NG >> Repair or replace damaged parts.

6. CHECK DTC

Perform [AT-120, "Diagnostic Trouble Code \(DTC\) Confirmation Procedure"](#).

OK or NG

- OK >> **INSPECTION END**
- NG >> GO TO 7.

7. CHECK TCM INSPECTION

1. Perform TCM input/output signal inspection.
2. If NG, recheck TCM pin terminals for damage or loose connection with harness connector.

OK or NG

- OK >> **INSPECTION END**
- NG >> Repair or replace damaged parts.

DTC P0731 A/T 1ST GEAR FUNCTION

DTC P0731 A/T 1ST GEAR FUNCTION

PFP:31940

Description

ECS006BJ

- This is an OBD-II self-diagnostic item and not available in TCM self-diagnosis.
- This malfunction will not be detected while the A/T check (position) indicator lamp is indicating another self-diagnosis malfunction.
- This malfunction is detected when the A/T does not shift into first gear position as instructed by the TCM. This is not caused by electrical malfunction (circuits open or shorted) but by mechanical malfunction such as control valve sticking, improper solenoid valve operation, etc.

Gear position	1	2	3	4
Shift solenoid valve A	ON (Closed)	OFF (Open)	OFF (Open)	ON (Closed)
Shift solenoid valve B	ON (Closed)	ON (Closed)	OFF (Open)	OFF (Open)

On Board Diagnosis Logic

ECS006BK

This diagnosis monitors actual gear position by checking the torque converter slip ratio calculated by TCM as follows:

Torque converter slip ratio = $A \times C/B$

A: Output shaft revolution signal from revolution sensor

B: Engine speed signal from ECM

C: Gear ratio determined as gear position which TCM supposes

If the actual gear position is higher than the position (1st) supposed by TCM, the slip ratio will be more than normal. In case the ratio exceeds the specified value, TCM judges this diagnosis malfunction.

This malfunction will be caused when either shift solenoid valve A is stuck open or shift solenoid valve B is stuck open.

Gear positions supposed by TCM are as follows.

In case of gear position with no malfunctions: **1** , 2, 3 and 4 positions

In case of gear position with shift solenoid valve A stuck open: **2*** , 2, 3 and 3 positions

In case of gear position with shift solenoid valve B stuck open: **4*** , 3, 3 and 4 positions to each gear position above

*: P0731 is detected.

Diagnostic trouble code A/T 1ST GR FNCTN with CONSULT-II or P0731 without CONSULT-II is detected when A/T cannot be shifted to the 1st gear position even if electrical circuit is good.

Possible Cause

ECS006BL

Check the following items.

- Shift solenoid valve A
- Shift solenoid valve B
- Each clutch
- Hydraulic control circuit

Diagnostic Trouble Code (DTC) Confirmation Procedure

ECS006BM

CAUTION:

- Always drive vehicle at a safe speed.
- Be careful not to rev engine into the red zone on the tachometer.

NOTE:

If "DTC Confirmation Procedure" has been previously conducted, always turn ignition switch OFF and wait at least 10 seconds before conducting the next test.

TESTING CONDITION:

Always drive vehicle on a level road to improve the accuracy of test.

After the repair, perform the following procedure to confirm the malfunction is eliminated.

DTC P0731 A/T 1ST GEAR FUNCTION

WITH CONSULT-II

1. Start engine and select "DATA MONITOR" mode for "A/T" with CONSULT-II.
2. Make sure that output voltage of A/T fluid temperature sensor is within the range below.
FLUID TEMP SEN: 0.4 - 1.5V
If out of range, drive the vehicle to decrease the voltage (warm up the fluid) or stop engine to increase the voltage (cool down the fluid).
3. Select "1ST GR FNCTN P0731" of "DTC WORK SUPPORT" mode for "A/T" with CONSULT-II and touch "START".

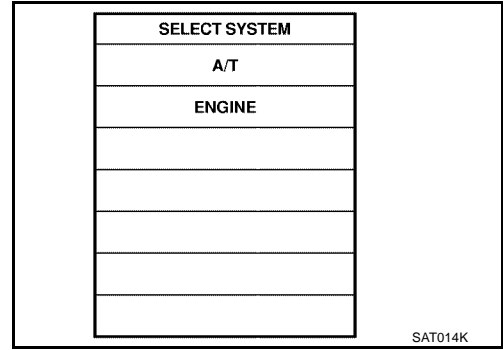

4. Accelerate vehicle to 20 to 25 km/h (12 to 16 MPH) under the following condition and release the accelerator pedal completely.

THROTTLE POSI: Less than 1.0/8 (at all times during step 4)
Selector lever: D position

- Check that "GEAR" shows "2" after releasing pedal.

5. Depress accelerator pedal to WOT (more than 7.0/8 of "THROTTLE POSI") quickly from a speed of 20 to 25 km/h (12 to 16 MPH) until "TESTING" changes to "STOP VEHICLE" or "COMPLETED". (It will take approximately 3 seconds.)

If the check result NG appears on CONSULT-II screen, go to [AT-127, "Diagnostic Procedure"](#).

If "STOP VEHICLE" appears on CONSULT-II screen, go to the following step.

- Check that "GEAR" shows "1" when depressing accelerator pedal to WOT.
- If "TESTING" does not appear on CONSULT-II for a long time, select "SELF-DIAG RESULTS" for "ENGINE". In case a 1st trip DTC other than P0731 is shown, refer to applicable "TROUBLE DIAGNOSIS FOR DTC".

6. Stop vehicle.
7. Follow the instruction displayed. (Check for normal shifting referring to the table below.)

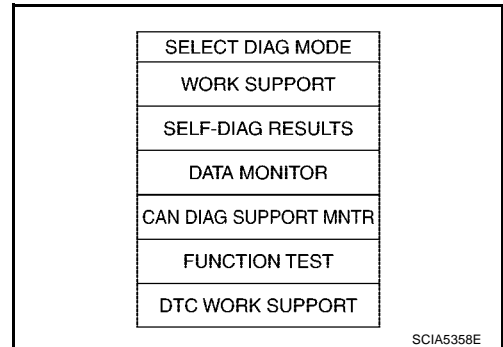

Vehicle condition	Gear on actual transmission shift pattern when screen is changed to 1 → 2 → 3 → 4
No malfunction exists.	1 → 2 → 3 → 4
Malfunction for P0731 exists.	2 → 2 → 3 → 3
	4 → 3 → 3 → 4

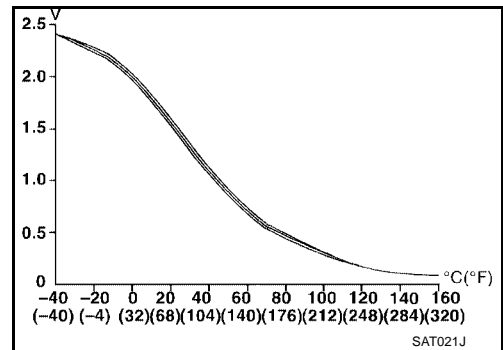

8. Make sure that "OK" is displayed. (If "NG" is displayed, refer to "DIAGNOSTIC PROCEDURE".)
Refer to [AT-127, "Diagnostic Procedure"](#).
Refer to [AT-373, "Shift Schedule"](#).

WITH GST

Follow the procedure "With CONSULT-II".

DTC P0731 A/T 1ST GEAR FUNCTION

Wiring Diagram — AT — 1ST

ECS006BN

AT-1STSIG-01

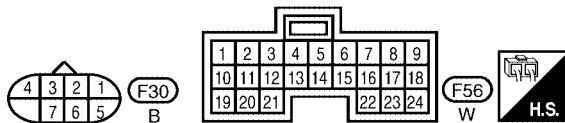
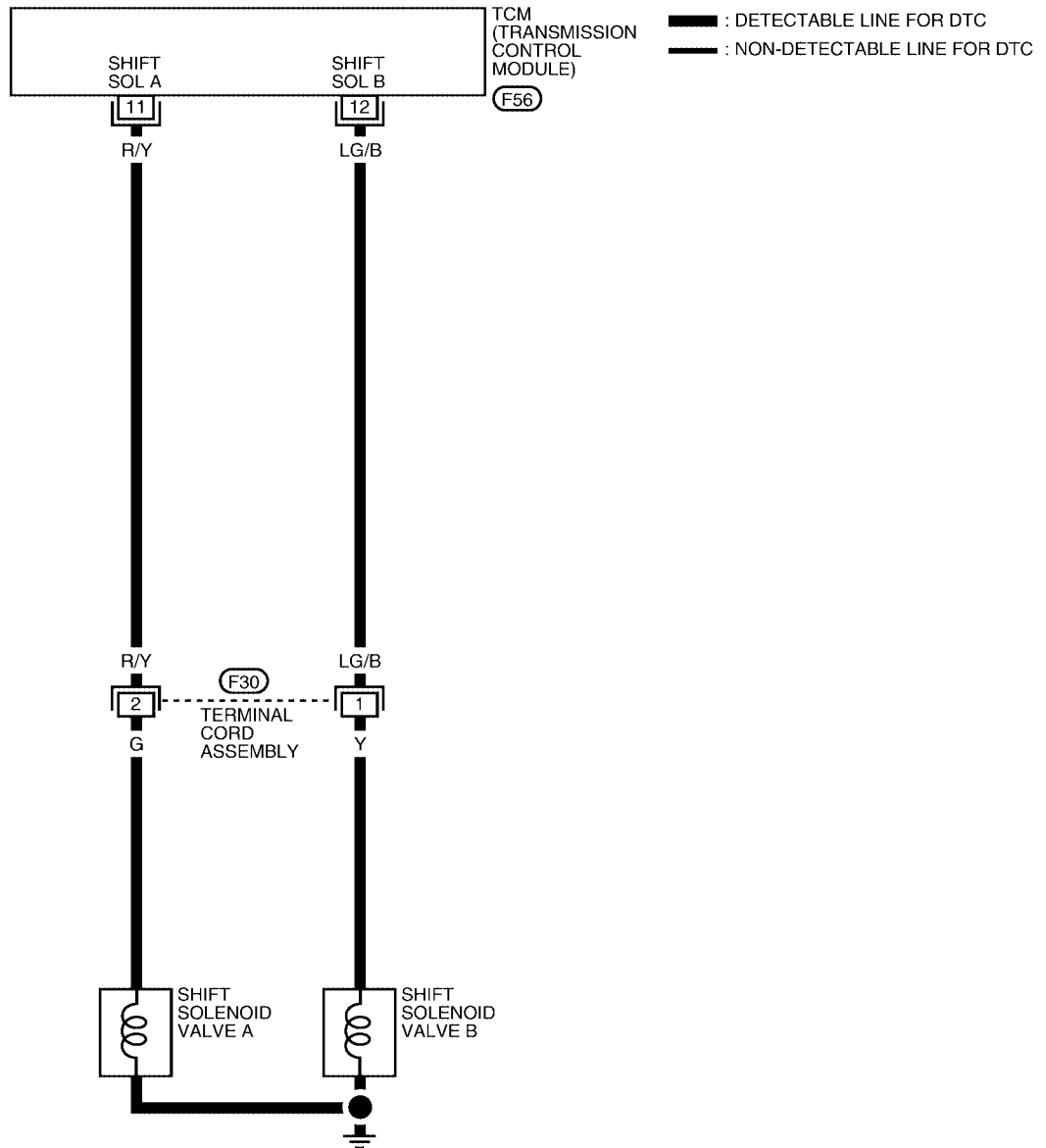

LCWA0010E

DTC P0731 A/T 1ST GEAR FUNCTION

TCM TERMINALS AND REFERENCE VALUE MEASURED BETWEEN EACH TERMINAL AND 25 OR 48 (TCM GROUND)

TERMINAL	WIRE COLOR	ITEM	CONDITION	DATA (APPROX.)
11	R/Y	SHIFT SOLENOID VALVE A	WHEN SHIFT SOLENOID VALVE A IS OPERATING (DRIVING IN D1 OR D4)	BATTERY VOLTAGE
			WHEN SHIFT SOLENOID VALVE A IS NOT OPERATING (DRIVING IN D2 OR D3)	0V
12	LG/B	SHIFT SOLENOID VALVE B	WHEN SHIFT SOLENOID VALVE B IS OPERATING (DRIVING IN D1 OR D2)	BATTERY VOLTAGE
			WHEN SHIFT SOLENOID VALVE B IS NOT OPERATING (DRIVING IN D3 OR D4)	0V

Diagnostic Procedure

ECS006B0

1. CHECK VALVE RESISTANCE

- Remove control valve assembly. Refer to [AT-264, "Control Valve Assembly and Accumulators"](#) .
 - Shift solenoid valve A
 - Shift solenoid valve B
- Check resistance between two terminals.

Solenoid valve	Terminal No.	Resistance (Approx.)
Shift solenoid valve A	2	20 - 30Ω
Shift solenoid valve B	1	

OK or NG

- OK >> GO TO 2.
 NG >> Repair or replace damaged parts.

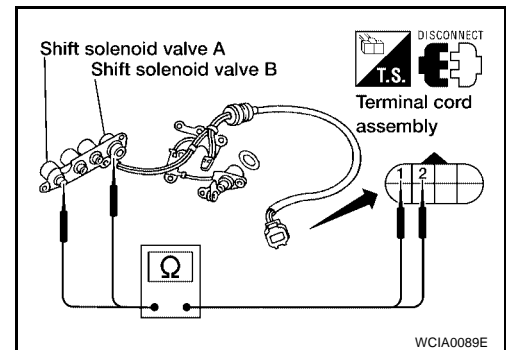

2. CHECK VALVE OPERATION

- Remove control valve assembly. Refer to [AT-264, "Control Valve Assembly and Accumulators"](#) .
 - Shift solenoid valve A
 - Shift solenoid valve B
- Check solenoid valve by listening for its operating sound while applying battery voltage to the terminal and ground.

OK or NG

- OK >> GO TO 3.
 NG >> Repair or replace shift solenoid valve assembly.

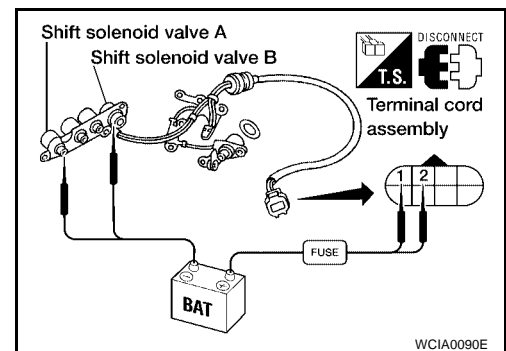

DTC P0731 A/T 1ST GEAR FUNCTION

3. CHECK CONTROL VALVE

1. Disassemble control valve assembly. Refer to [AT-299, "Control Valve Assembly"](#) .
2. Check to ensure that:
 - Valve, sleeve and plug slide along valve bore under their own weight.
 - Valve, sleeve and plug are free from burrs, dents and scratches.
 - Control valve springs are free from damage, deformation and fatigue.
 - Hydraulic line is free from obstacles.

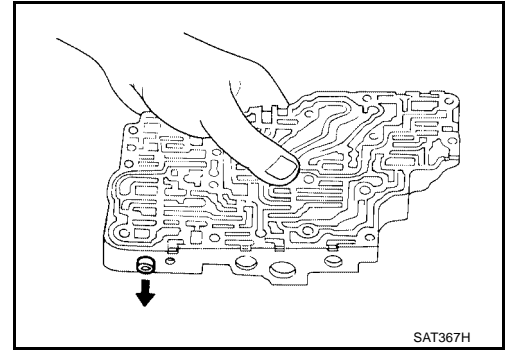

OK or NG

- OK >> GO TO 4.
- NG >> Repair control valve assembly.

4. CHECK DTC

Perform [AT-124, "Diagnostic Trouble Code \(DTC\) Confirmation Procedure"](#) .

OK or NG

- OK >> **INSPECTION END**
- NG >> Check control valve again. Repair or replace control valve assembly.

DTC P0732 A/T 2ND GEAR FUNCTION

DTC P0732 A/T 2ND GEAR FUNCTION

PFP:31940

Description

ECS006BP

- This is an OBD-II self-diagnostic item and not available in TCM self-diagnosis.
- This malfunction will not be detected while the A/T check (position) indicator lamp is indicating another self-diagnosis malfunction.
- This malfunction is detected when the A/T does not shift into second gear position as instructed by the TCM. This is not caused by electrical malfunction (circuits open or shorted) but by mechanical malfunction such as control valve sticking, improper solenoid valve operation, etc.

Gear position	1	2	3	4
Shift solenoid valve A	ON (Closed)	OFF (Open)	OFF (Open)	ON (Closed)
Shift solenoid valve B	ON (Closed)	ON (Closed)	OFF (Open)	OFF (Open)

On Board Diagnosis Logic

ECS006BQ

This diagnosis monitors actual gear position by checking the torque converter slip ratio calculated by TCM as follows:

Torque converter slip ratio = A x C/B

A: Output shaft revolution signal from revolution sensor

B: Engine speed signal from ECM

C: Gear ratio determined as gear position which TCM supposes

If the actual gear position is higher than the position (2nd) supposed by TCM, the slip ratio will be more than normal. In case the ratio exceeds the specified value, TCM judges this diagnosis malfunction.

This malfunction will be caused when shift solenoid valve B is stuck open.

Gear positions supposed by TCM are as follows.

In case of gear position with no malfunctions: 1, 2, 3 and 4 positions

In case of gear position with shift solenoid valve B stuck open: 4, 3*, 3 and 4 positions to each gear position above

*: P0732 is detected.

Diagnostic trouble code A/T 2ND GR FNCTN with CONSULT-II or P0732 without CONSULT-II is detected when A/T cannot be shifted to the 2nd gear position even if electrical circuit is good.

Possible Cause

ECS006BR

Check the following items.

- Shift solenoid valve B
- Each clutch
- Hydraulic control circuit

Diagnostic Trouble Code (DTC) Confirmation Procedure

ECS006BS

CAUTION:

- Always drive vehicle at a safe speed.
- Be careful not to rev engine into the red zone on the tachometer.

NOTE:

If "DTC Confirmation Procedure" has been previously conducted, always turn ignition switch OFF and wait at least 10 seconds before conducting the next test.

TESTING CONDITION:

Always drive vehicle on a level road to improve the accuracy of test.

After the repair, perform the following procedure to confirm the malfunction is eliminated.

DTC P0732 A/T 2ND GEAR FUNCTION

WITH CONSULT-II

1. Start engine and select "DATA MONITOR" mode for "A/T" with CONSULT-II.
2. Make sure that output voltage of A/T fluid temperature sensor is within the range below.
FLUID TEMP SEN: 0.4 - 1.5V
If out of range, drive the vehicle to decrease the voltage (warm up the fluid) or stop engine to increase the voltage (cool down the fluid).
3. Select "2ND GR FNCTN P0732" of "DTC WORK SUPPORT" mode for "A/T" with CONSULT-II and touch "START".

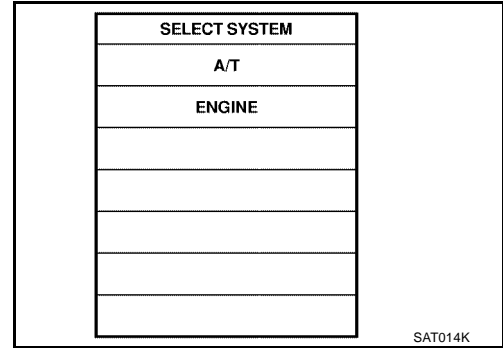

4. Accelerate vehicle to 45 to 50 km/h (28 to 31 MPH) under the following condition and release the accelerator pedal completely.

THROTTLE POSI: Less than 1.0/8

Selector lever: D position

- Check that "GEAR" shows "3" or "4" after releasing pedal.
5. Depress accelerator pedal to WOT (more than 7.0/8 of "THROTTLE POSI") quickly from a speed of 45 to 50 km/h (28 to 31 MPH) until "TESTING" changes to "STOP VEHICLE" or "COMPLETE". (It will take approximately 3 seconds.)
If the check result NG appears on CONSULT-II screen, go to [AT-132, "Diagnostic Procedure"](#).
If "STOP VEHICLE" appears on CONSULT-II screen, go to following step.
 - Check that "GEAR" shows "2" when depressing accelerator pedal to WOT.
 - If "TESTING" does not appear on CONSULT-II for a long time, select "SELF-DIAG RESULTS" for "ENGINE". In case a 1st trip DTC other than P0732 is shown, refer to applicable "TROUBLE DIAGNOSIS FOR DTC".
 6. Stop vehicle.
 7. Follow the instruction displayed. (Check for normal shifting referring to the table below.)

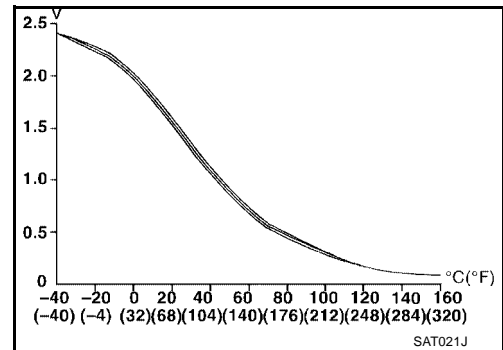
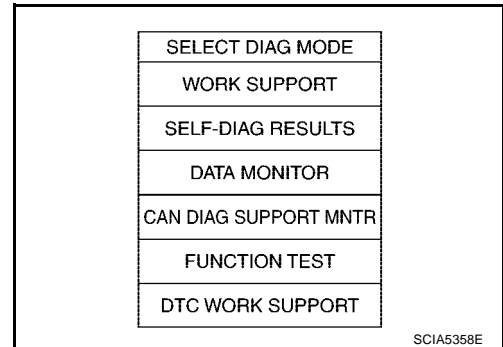

Vehicle condition	Gear on actual transmission shift pattern when screen is changed to 1 → 2 → 3 → 4
No malfunction exists	1 → 2 → 3 → 4
Malfunction for P0732 exists.	4 → 3 → 3 → 4

8. Make sure that "OK" is displayed. (If "NG" is displayed, refer to "DIAGNOSTIC PROCEDURE".)
Refer to [AT-132, "Diagnostic Procedure"](#).
Refer to [AT-373, "Shift Schedule"](#).

WITH GST

Follow the procedure "With CONSULT-II".

DTC P0732 A/T 2ND GEAR FUNCTION

Wiring Diagram — AT — 2ND

ECS006BT

AT-2NDSIG-01

A
B
AT
D
E
F
G
H
I
J
K
L
M

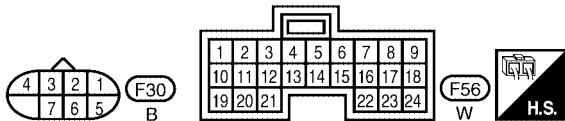
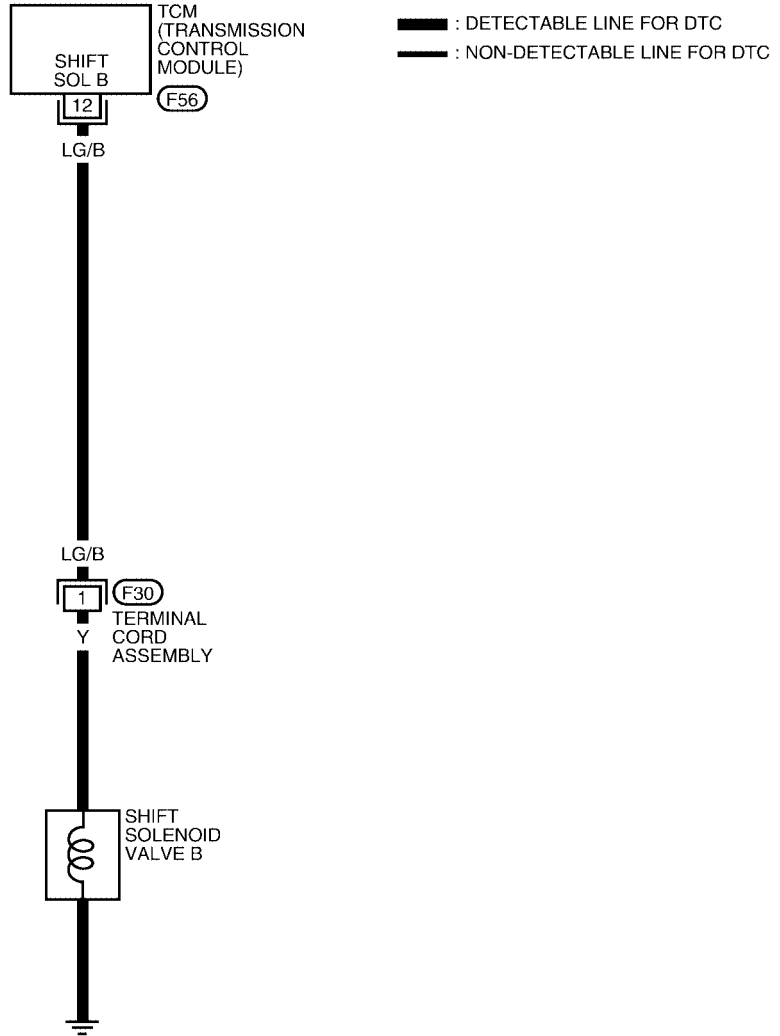

LCWA0011E

DTC P0732 A/T 2ND GEAR FUNCTION

TCM TERMINALS AND REFERENCE VALUE MEASURED BETWEEN EACH TERMINAL AND 25 OR 48 (TCM GROUND)

TERMINAL	WIRE COLOR	ITEM	CONDITION	DATA (APPROX.)
12	LG/B	SHIFT SOLENOID VALVE B	WHEN SHIFT SOLENOID VALVE B IS OPERATING (DRIVING IN D1 OR D2)	BATTERY VOLTAGE
			WHEN SHIFT SOLENOID VALVE B IS NOT OPERATING (DRIVING IN D3 OR D4)	0V

Diagnostic Procedure

ECS006BU

1. CHECK VALVE RESISTANCE

- Remove control valve assembly. Refer to [AT-264, "Control Valve Assembly and Accumulators"](#).
 - Shift solenoid valve B
- Check resistance to the terminal and ground.

Solenoid valve	Terminal No.	Resistance (Approx.)
Shift solenoid valve B	1 Ground	5 - 20Ω

OK or NG

- OK >> GO TO 2.
 NG >> Repair or replace shift solenoid valve assembly.

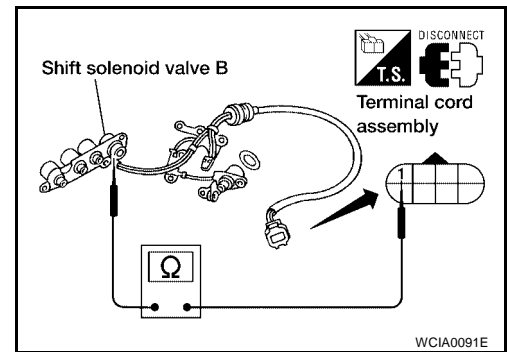

2. CHECK VALVE OPERATION

- Remove control valve assembly. Refer to [AT-264, "Control Valve Assembly and Accumulators"](#).
 - Shift solenoid valve B
- Check solenoid valve by listening for its operating sound while applying battery voltage to the terminal and ground.

OK or NG

- OK >> GO TO 3.
 NG >> Repair or replace shift solenoid valve assembly.

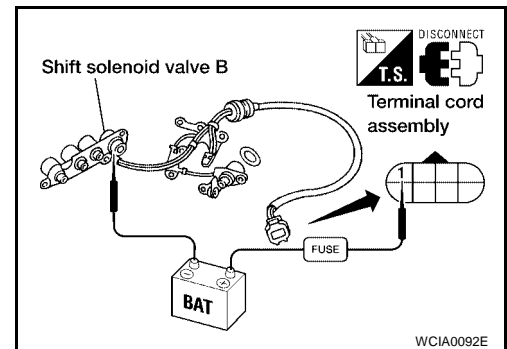

3. CHECK CONTROL VALVE

- Disassemble control valve assembly. Refer to [AT-299, "Control Valve Assembly"](#).
- Check to ensure that:
 - Valve, sleeve and plug slide along valve bore under their own weight.
 - Valve, sleeve and plug are free from burrs, dents and scratches.
 - Control valve springs are free from damage, deformation and fatigue.
 - Hydraulic line is free from obstacles.

OK or NG

- OK >> GO TO 4.
 NG >> Repair control valve assembly.

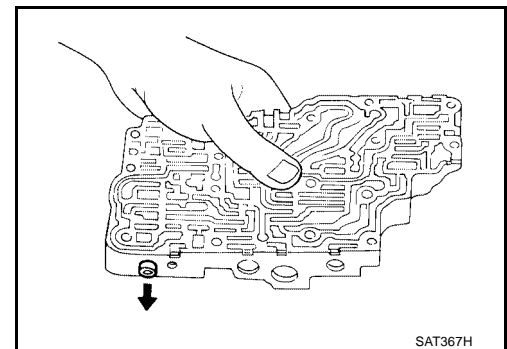

DTC P0732 A/T 2ND GEAR FUNCTION

4. CHECK DTC

Perform [AT-129, "Diagnostic Trouble Code \(DTC\) Confirmation Procedure"](#) .

OK or NG

OK >> **INSPECTION END**

NG >> Check control valve again. Repair or replace control valve assembly.

A

B

AT

D

E

F

G

H

I

J

K

L

M

DTC P0733 A/T 3RD GEAR FUNCTION

DTC P0733 A/T 3RD GEAR FUNCTION

PFP:31940

Description

ECS006BV

- This is an OBD-II self-diagnostic item and not available in TCM self-diagnosis.
- This malfunction will not be detected while the A/T check (position) indicator lamp is indicating another self-diagnosis malfunction.
- This malfunction is detected when the A/T does not shift into third gear position as instructed by the TCM. This is not caused by electrical malfunction (circuits open or shorted) but by mechanical malfunction such as control valve sticking, improper solenoid valve operation, malfunctioning servo piston or brake band, etc.

Gear position	1	2	3	4
Shift solenoid valve A	ON (Closed)	OFF (Open)	OFF (Open)	ON (Closed)
Shift solenoid valve B	ON (Closed)	ON (Closed)	OFF (Open)	OFF (Open)

On Board Diagnosis Logic

ECS006BW

This diagnosis monitors actual gear position by checking the torque converter slip ratio calculated by TCM as follows:

Torque converter slip ratio = $A \times C/B$

A: Output shaft revolution signal from revolution sensor

B: Engine speed signal from ECM

C: Gear ratio determined as gear position which TCM supposes

If the actual gear position is higher than the position (3rd) supposed by TCM, the slip ratio will be more than normal. In case the ratio exceeds the specified value, TCM judges this diagnosis malfunction.

This malfunction will be caused when shift solenoid valve A is stuck closed.

Gear positions supposed by TCM are as follows.

In case of gear position with no malfunctions: 1, 2, **3** and 4 positions

In case of gear position with shift solenoid valve A stuck closed: 1, 1, **4*** and 4 positions to each gear position above

*: P0733 is detected.

Diagnostic trouble code A/T 3RD GR FNCTN with CONSULT-II or P0733 without CONSULT-II is detected when A/T cannot be shifted to the 3rd gear position even if electrical circuit is good.

Possible Cause

ECS006BX

Check the following items.

- Shift solenoid valve A
- Each clutch
- Hydraulic control circuit

Diagnostic Trouble Code (DTC) Confirmation Procedure

ECS006BY

CAUTION:

- Always drive vehicle at a safe speed.
- Be careful not to rev engine into the red zone on the tachometer.

NOTE:

If "DTC Confirmation Procedure" has been previously conducted, always turn ignition switch "OFF" and wait at least 10 seconds before conducting the next test.

TESTING CONDITION:

Always drive vehicle on a level road to improve the accuracy of test.

After the repair, perform the following procedure to confirm the malfunction is eliminated.

DTC P0733 A/T 3RD GEAR FUNCTION

WITH CONSULT-II

1. Start engine and select "DATA MONITOR" mode for "A/T" with CONSULT-II.
2. Make sure that output voltage of A/T fluid temperature sensor is within the range below.
FLUID TEMP SEN: 0.4 - 1.5V
If out of range, drive the vehicle to decrease the voltage (warm up the fluid) or stop engine to increase the voltage (cool down the fluid).
3. Select "3RD GR FNCTN P0733" of "DTC WORK SUPPORT" mode for "A/T" with CONSULT-II and touch "START".

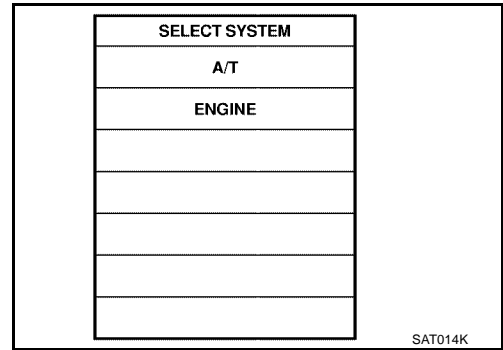

4. Accelerate vehicle to 60 to 75 km/h (37 to 47 MPH) under the following condition and release the accelerator pedal completely.

THROTTLE POSI: Less than 1.0/8 (at all times during step 4)
Selector lever: D position

- Check that "GEAR" shows "4" after releasing pedal.
5. Depress accelerator pedal steadily with 3.5/8 - 4.5/8 of "THROTTLE POSI" from a speed of 60 to 75 km/h (37 to 47 MPH) until "TESTING" changes to "STOP VEHICLE" or "COMPLETED". (It will take approximately 3 seconds.)
If the check result NG appears on CONSULT-II screen, go to [AT-137, "Diagnostic Procedure"](#).
If "STOP VEHICLE" appears on CONSULT-II screen, go to following step.
 - Check that "GEAR" shows "3" when depressing accelerator pedal with 3.5/8 - 4.5/8 of "THROTTLE POSI".
 - If "TESTING" does not appear on CONSULT-II for a long time, select "SELF-DIAG RESULTS" for "ENGINE". In case a 1st trip DTC other than P0733 is shown, refer to applicable "TROUBLE DIAGNOSIS FOR DTC".
 6. Stop vehicle.
 7. Follow the instruction displayed. (Check for normal shifting referring to the table below.)

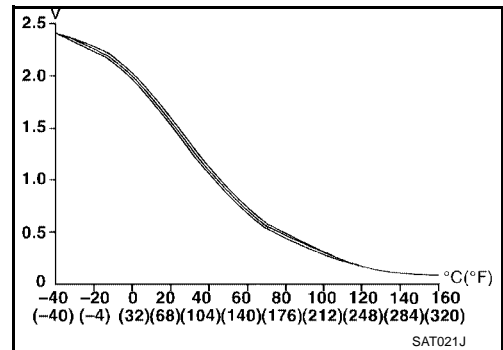
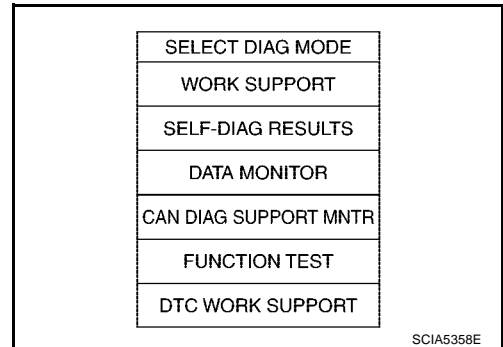

Vehicle condition	Gear on actual transmission shift pattern when screen is changed to 1 → 2 → 3 → 4
No malfunction exists.	1 → 2 → 3 → 4
Malfunction for P0733 exists.	1 → 1 → 4 → 4

8. Make sure that "OK" is displayed. (If "NG" is displayed, refer to "DIAGNOSTIC PROCEDURE".)
Refer to [AT-137, "Diagnostic Procedure"](#).
Refer to [AT-373, "Shift Schedule"](#).

WITH GST

Follow the procedure "With CONSULT-II".

DTC P0733 A/T 3RD GEAR FUNCTION

Wiring Diagram — AT — 3RD

ECS006BZ

AT-3RDSIG-01

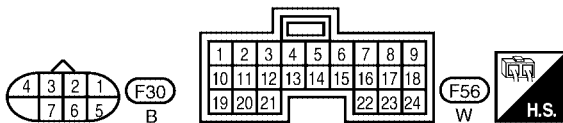
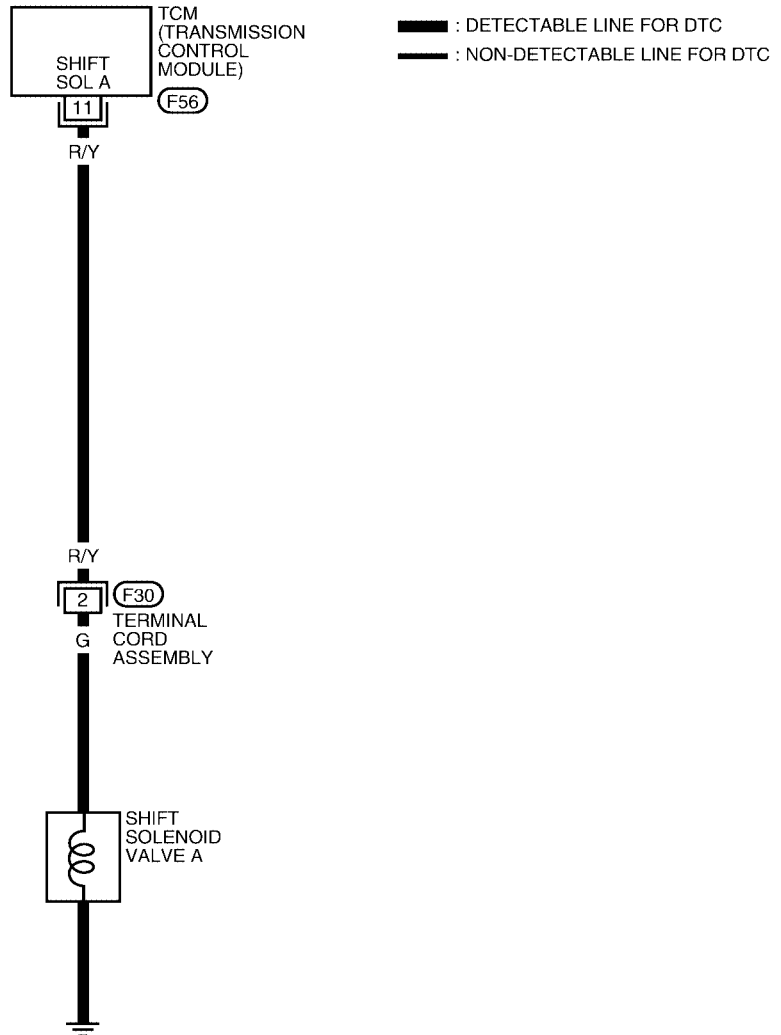

LCWA0012E

DTC P0733 A/T 3RD GEAR FUNCTION

TCM TERMINALS AND REFERENCE VALUE MEASURED BETWEEN EACH TERMINAL AND 25 OR 48 (TCM GROUND)

TERMINAL	WIRE COLOR	ITEM	CONDITION	DATA (APPROX.)
11	R/Y	SHIFT SOLENOID VALVE A	WHEN SHIFT SOLENOID VALVE A IS OPERATING (DRIVING IN D1 OR D4)	BATTERY VOLTAGE
			WHEN SHIFT SOLENOID VALVE A IS NOT OPERATING (DRIVING IN D2 OR D3)	0V

Diagnostic Procedure

ECS006C0

1. CHECK VALVE RESISTANCE

- Remove control valve assembly. Refer to [AT-264, "Control Valve Assembly and Accumulators"](#) .
 - Shift solenoid valve A
- Check resistance to the terminal and ground.

Solenoid valve	Terminal No.	Resistance (Approx.)
Shift solenoid valve A	2 Ground	20 - 30Ω

OK or NG

- OK >> GO TO 2.
 NG >> Repair or replace shift solenoid valve assembly.

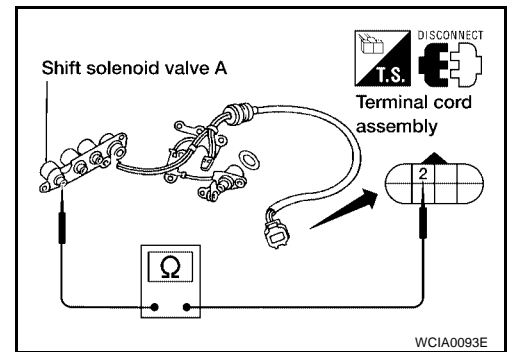

WCIA0093E

2. CHECK VALVE OPERATION

- Remove control valve assembly. Refer to [AT-264, "Control Valve Assembly and Accumulators"](#) .
 - Shift solenoid valve A
- Check solenoid valve by listening for its operating sound while applying battery voltage to the terminal and ground.

OK or NG

- OK >> GO TO 3.
 NG >> Repair or replace shift solenoid valve assembly.

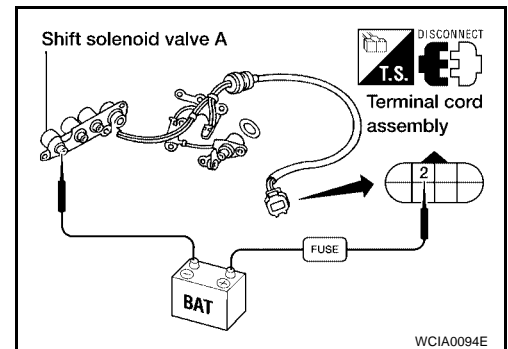

WCIA0094E

3. CHECK CONTROL VALVE

- Disassemble control valve assembly. Refer to [AT-299, "Control Valve Assembly"](#) .
- Check to ensure that:
 - Valve, sleeve and plug slide along valve bore under their own weight.
 - Valve, sleeve and plug are free from burrs, dents and scratches.
 - Control valve springs are free from damage, deformation and fatigue.
 - Hydraulic line is free from obstacles.

OK or NG

- OK >> GO TO 4.
 NG >> Repair control valve assembly.

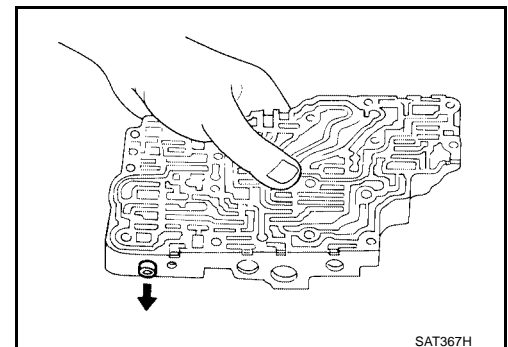

SAT367H

DTC P0733 A/T 3RD GEAR FUNCTION

4. CHECK DTC

Perform [AT-134, "Diagnostic Trouble Code \(DTC\) Confirmation Procedure"](#) .

OK or NG

OK >> **INSPECTION END**

NG >> Check control valve again. Repair or replace control valve assembly.

DTC P0734 A/T 4TH GEAR FUNCTION

DTC P0734 A/T 4TH GEAR FUNCTION

PF3:31940

Description

ECS006C1

- This is an OBD-II self-diagnostic item and not available in TCM self-diagnosis.
- This malfunction will not be detected while the A/T check (position) indicator lamp is indicating another self-diagnosis malfunction.
- This malfunction is detected when the A/T does not shift into fourth gear position or the torque converter clutch does not lock up as instructed by the TCM. This is not caused by electrical malfunction (circuits open or shorted) but by mechanical malfunction such as control valve sticking, improper solenoid valve operation, malfunctioning oil pump or torque converter clutch, etc.

Gear position	1	2	3	4
Shift solenoid valve A	ON (Closed)	OFF (Open)	OFF (Open)	ON (Closed)
Shift solenoid valve B	ON (Closed)	ON (Closed)	OFF (Open)	OFF (Open)

CONSULT-II REFERENCE VALUE IN DATA MONITOR MODE

Remarks: Specification data are reference values.

Monitor item	Condition	Specification
Torque converter clutch solenoid valve duty	Lock-up OFF	Approximately 4%
	↓ Lock-up ON	↓ Approximately 94%
Line pressure solenoid valve duty	Small throttle opening (Low line pressure)	Approximately 24%
	↓ Large throttle opening (High line pressure)	↓ Approximately 95%

On Board Diagnosis Logic

ECS006C2

This diagnosis monitors actual gear position by checking the torque converter slip ratio calculated by TCM as follows:

Torque converter slip ratio = A x C/B

A: Output shaft revolution signal from revolution sensor

B: Engine speed signal from ECM

C: Gear ratio determined as gear position which TCM supposes

If the actual gear position is much lower than the position (4th) supposed by TCM, the slip ratio will be much less than normal. In case the ratio does not reach the specified value, TCM judges this diagnosis malfunction. This malfunction will be caused when shift solenoid valve B is stuck closed.

Gear positions supposed by TCM are as follows.

In case of gear position with no malfunctions: 1, 2, 3 and 4 positions

In case of gear position with shift solenoid valve B stuck closed: 1, 2, 2 and 1* positions to each gear position above

*: P0734 is detected.

Diagnostic trouble code A/T 4TH GR FNCTN with CONSULT-II or P0734 without CONSULT-II is detected when A/T cannot be shifted to the 4th gear position even if electrical circuit is good.

Possible Cause

ECS006C3

Check the following items.

- Shift solenoid valve A
- Shift solenoid valve B
- Line pressure solenoid valve
- Each clutch
- Hydraulic control circuit

Diagnostic Trouble Code (DTC) Confirmation Procedure

ECS006C4

CAUTION:

- Always drive vehicle at a safe speed.
- If conducting this "DTC CONFIRMATION PROCEDURE" again, always turn ignition switch OFF and wait at least 10 seconds before continuing.
- Be careful not to rev engine into the red zone on the tachometer.

DTC P0734 A/T 4TH GEAR FUNCTION

NOTE:

If "DTC Confirmation Procedure" has been previously conducted, always turn ignition switch OFF and wait at least 10 seconds before conducting the next test.

TESTING CONDITION:

Always drive vehicle on a level road to improve the accuracy of test.

After the repair, perform the following procedure to confirm the malfunction is eliminated.

WITH CONSULT-II

1. Start engine and select "DATA MONITOR" mode for "A/T" with CONSULT-II.
2. Make sure that output voltage of A/T fluid temperature sensor is within the range below.
FLUID TEMP SEN: 0.4 - 1.5V
 If out of range, drive the vehicle to decrease the voltage (warm up the fluid) or stop engine to increase the voltage (cool down the fluid).
3. Select "4TH GR FNCTN P0734" of "DTC WORK SUPPORT" mode for "A/T" with CONSULT-II and touch "START".

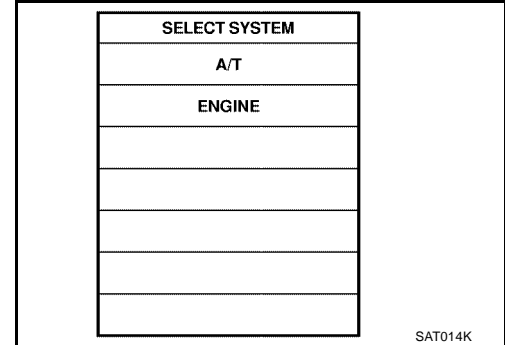

4. Accelerate vehicle to 55 to 65 km/h (34 to 40 MPH) under the following condition and release the accelerator pedal completely.

THROTTLE POSI: Less than 5.5/8 (at all times during step 4)
Selector lever: D position

- Check that "GEAR" shows "3" after releasing pedal.
5. Depress accelerator pedal steadily with 1.0/8 - 2.0/8 of "THROTTLE POSI" from a speed of 55 to 65 km/h (34 to 40 MPH) until "TESTING" has turned to "STOP VEHICLE" or "COMPLETED". (It will take approximately 3 seconds.)

If the check result NG appears on CONSULT-II screen, go to [AT-142, "Diagnostic Procedure"](#).

If "STOP VEHICLE" appears on CONSULT-II screen, go to following step.

- Check that "GEAR" shows "4" when depressing accelerator pedal with 1.0/8 - 2.0/8 of "THROTTLE POSI".
- If "TESTING" does not appear on CONSULT-II for a long time, select "SELF-DIAG RESULTS" for "ENGINE". In case a 1st trip DTC other than P0734 is shown, refer to applicable "TROUBLE DIAGNOSIS FOR DTC".

6. Stop vehicle.
7. Follow the instruction displayed. (Check for normal shifting referring to the table below.)

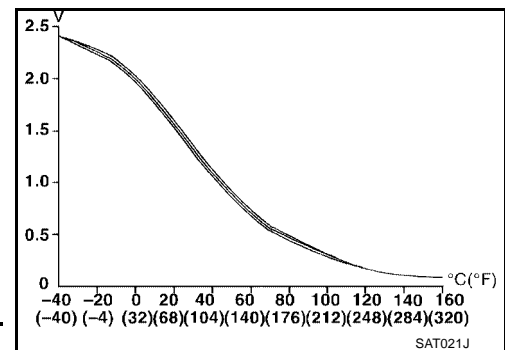
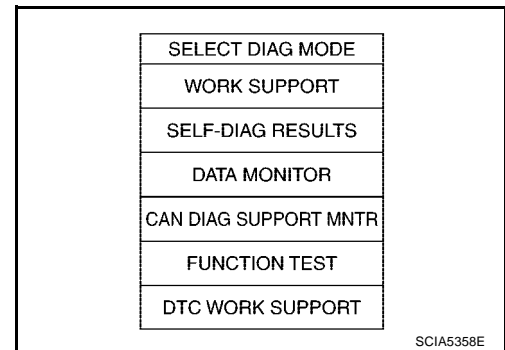

Vehicle condition	Gear on actual transmission shift pattern when screen is changed to 1 → 2 → 3 → 4
No malfunction exists	1 → 2 → 3 → 4
Malfunction for P0734 exists.	1 → 2 → 2 → 1

8. Make sure that "OK" is displayed. (If "NG" is displayed, refer to "DIAGNOSTIC PROCEDURE".)
 Refer to [AT-142, "Diagnostic Procedure"](#).
 Refer to [AT-373, "Shift Schedule"](#).

WITH GST



Follow the procedure "With CONSULT-II".

DTC P0734 A/T 4TH GEAR FUNCTION

Wiring Diagram — AT — 4TH

ECS006C5

AT-4THSIG-01

- : DETECTABLE LINE FOR DTC
- : NON-DETECTABLE LINE FOR DTC
-  : WITH QR25DE
-  : WITH VQ35DE

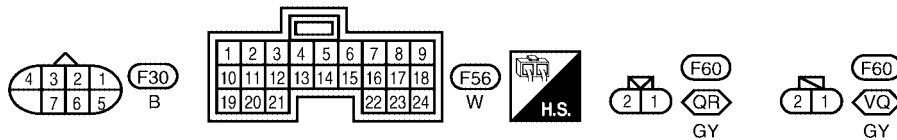
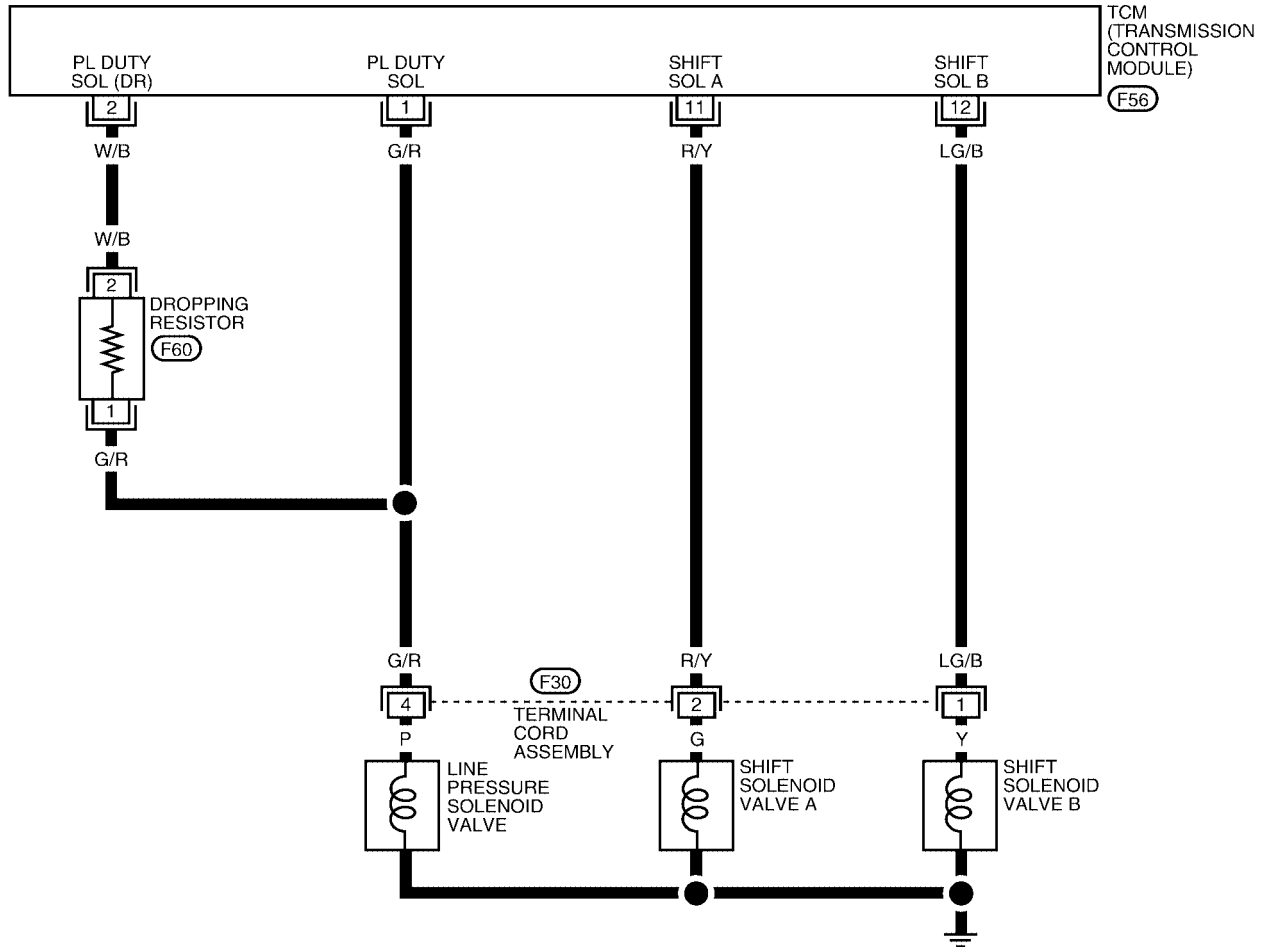

WCWA0050E

DTC P0734 A/T 4TH GEAR FUNCTION

TCM TERMINALS AND REFERENCE VALUE MEASURED BETWEEN EACH TERMINAL AND 25 OR 48 (TCM GROUND)

TERMINAL	WIRE COLOR	ITEM	CONDITION	DATA (APPROX.)
1	G/R	LINE PRESSURE SOLENOID VALVE	WHEN ACCELERATOR PEDAL IS RELEASED WHILE DRIVING	1.5 - 3.0V
			WHEN ACCELERATOR PEDAL IS DEPRESSED WHILE DRIVING	0V
2	W/B	LINE PRESSURE SOLENOID VALVE (DROPPING RESISTOR)	WHEN ACCELERATOR PEDAL IS RELEASED WHILE DRIVING	4 - 14V
			WHEN ACCELERATOR PEDAL IS DEPRESSED WHILE DRIVING	0V
11	R/Y	SHIFT SOLENOID VALVE A	WHEN SHIFT SOLENOID VALVE A IS OPERATING (DRIVING IN D1 OR D4)	BATTERY VOLTAGE
			WHEN SHIFT SOLENOID VALVE A IS NOT OPERATING (DRIVING IN D2 OR D3)	0V
12	LG/B	SHIFT SOLENOID VALVE B	WHEN SHIFT SOLENOID VALVE B IS OPERATING (DRIVING IN D1 OR D2)	BATTERY VOLTAGE
			WHEN SHIFT SOLENOID VALVE BE IS NOT OPERATING (DRIVING IN D3 OR D4)	0V

Diagnostic Procedure

ECS006C6

1. CHECK SHIFT UP (D3 TO D4)

During [AT-75, "Cruise Test — Part 1"](#) , does A/T shift from D3 to D4 at the specified speed?

Yes or No

- Yes >> GO TO 11.
- No >> GO TO 2.

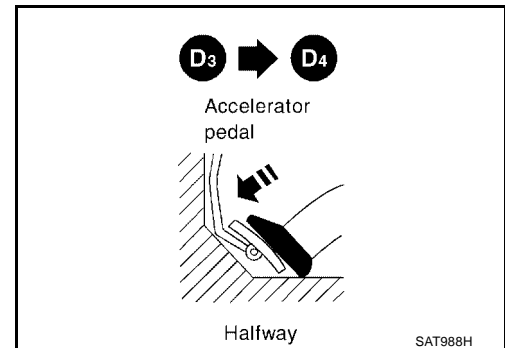

2. CHECK LINE PRESSURE

Perform line pressure test.

Engine Speed RPM	Line Pressure kPa (kg/cm ² , psi)			
	QR25DE		VQ35DE	
	D, 2 and 1 Position	R Position	D, 2 and 1 Position	R Position
Idle	500 (5.1, 73)	778 (7.9, 113)	500 (5.1, 73)	778 (7.9, 113)
Stall	1.233 (12.6, 179)	1.918 (19.6, 278)	1.233 (12.6, 179)	1.918 (19.6, 278)

Refer to [AT-65, "Line Pressure Test"](#) .

OK or NG

- OK >> GO TO 3.
- NG >> GO TO 7.

DTC P0734 A/T 4TH GEAR FUNCTION

3. CHECK VALVE RESISTANCE

- Remove control valve assembly. Refer to [AT-264, "Control Valve Assembly and Accumulators"](#) .
 - Shift solenoid valve A
 - Shift solenoid valve B
- Check resistance between two terminals.

Solenoid valve	Terminal No.	Resistance (Approx.)
Shift solenoid valve A	2	20 - 30Ω
Shift solenoid valve B	1	
	Ground	5 - 20Ω

OK or NG

- OK >> GO TO 5.
- NG >> Replace solenoid valve assembly.

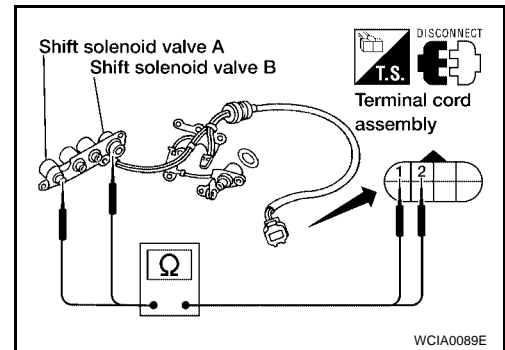

4. CHECK VALVE OPERATION

- Remove control valve assembly. Refer to [AT-264, "Control Valve Assembly and Accumulators"](#) .
 - Shift solenoid valve A
 - Shift solenoid valve B
- Check solenoid valve by listening for its operating sound while applying battery voltage to the terminal and ground.

OK or NG

- OK >> GO TO 5.
- NG >> Replace solenoid valve assembly.

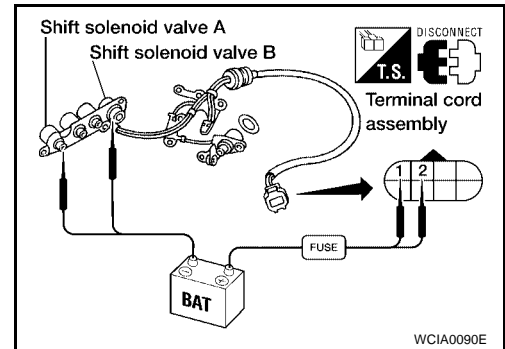

5. CHECK CONTROL VALVE

- Disassemble control valve assembly. Refer to [AT-299, "Control Valve Assembly"](#) .
- Check to ensure that:
 - Valve, sleeve and plug slide along valve bore under their own weight.
 - Valve, sleeve and plug are free from burrs, dents and scratches.
 - Control valve springs are free from damage, deformation and fatigue.
 - Hydraulic line is free from obstacles.

OK or NG

- OK >> GO TO 6.
- NG >> Repair control valve.

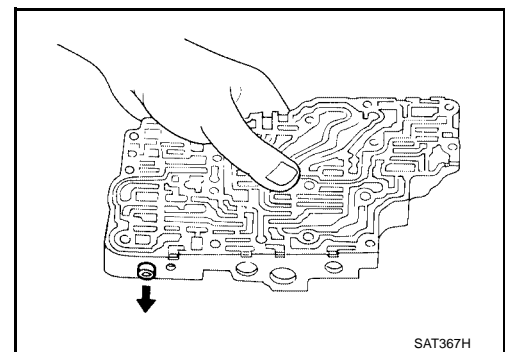

6. CHECK SHIFT UP (D3 TO D4)

Does A/T shift from D3 to D4 at the specified speed?

OK or NG

- OK >> GO TO 11.
- NG >> Check control valve again. Repair or replace control valve assembly.

DTC P0734 A/T 4TH GEAR FUNCTION

7. CHECK VALVE RESISTANCE

- Remove control valve assembly. Refer to [AT-264, "Control Valve Assembly and Accumulators"](#) .
 - Line pressure solenoid valves
- Check resistance to the terminal and ground.

Solenoid valve	Terminal No.		Resistance (Approx.)
Line pressure solenoid valve	4	Ground	2.5 - 5Ω

OK or NG

- OK >> GO TO 9.
 NG >> Replace solenoid valve assembly.

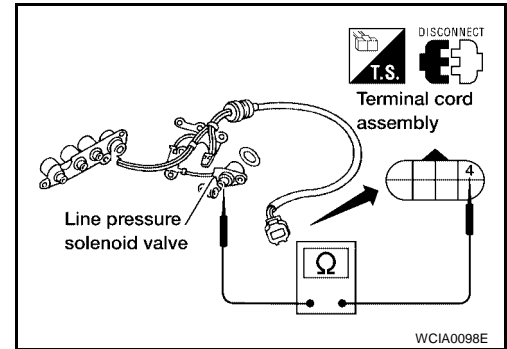

8. CHECK VALVE OPERATION

- Remove control valve assembly. Refer to [AT-264, "Control Valve Assembly and Accumulators"](#) .
 - Line pressure solenoid valves
- Check solenoid valve by listening for its operating sound while applying battery voltage to the terminal and ground.

OK or NG

- OK >> GO TO 9.
 NG >> Replace solenoid valve assembly.

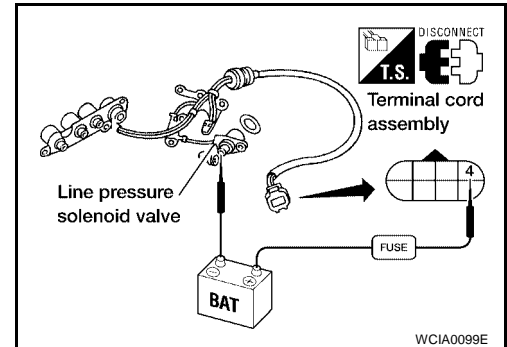

9. CHECK CONTROL VALVE

- Disassemble control valve assembly. Refer to [AT-299, "Control Valve Assembly"](#) .
- Check line pressure circuit valves for sticking.
 - Pressure regulator valve
 - Pilot valve
 - Pressure modifier valve

OK or NG

- OK >> GO TO 10.
 NG >> Repair control valve.

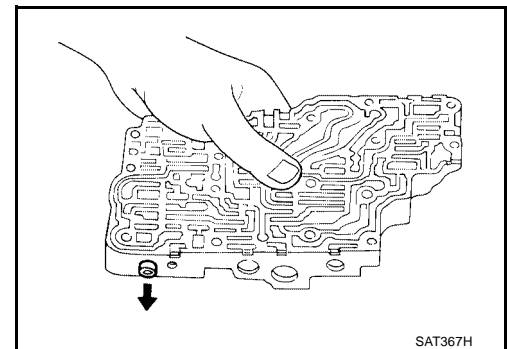

10. CHECK SHIFT UP (D3 TO D4)

Does A/T shift from D3 to D4 at the specified speed?

OK or NG

- OK >> GO TO 11.
 NG >> Check control valve again. Repair or replace control valve assembly.

DTC P0734 A/T 4TH GEAR FUNCTION

11. CHECK DTC

Perform [AT-139, "Diagnostic Trouble Code \(DTC\) Confirmation Procedure"](#) .

OK or NG

OK >> **INSPECTION END**

NG >> Perform "Cruise test — Part 1" again and return to the start point of this test group.

A

B

AT

D

E

F

G

H

I

J

K

L

M

DTC P0740 TORQUE CONVERTER CLUTCH SOLENOID VALVE

DTC P0740 TORQUE CONVERTER CLUTCH SOLENOID VALVE

PFP:31940

Description

ECS006C7

The torque converter clutch solenoid valve is activated, with the gear in D4, by the TCM in response to signals sent from the vehicle speed and the ECM (throttle opening). Lock-up piston operation will then be controlled.

Lock-up operation, however, is prohibited when A/T fluid temperature is too low.

When the accelerator pedal is depressed (less than 2/8) in lock-up condition, the engine speed should not change abruptly. If there is a big jump in engine speed, there is no lock-up.

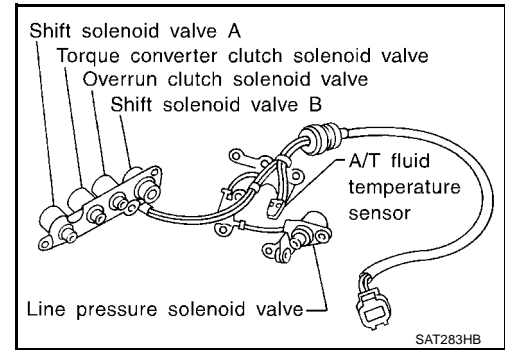

CONSULT-II REFERENCE VALUE IN DATA MONITOR MODE

Remarks: Specification data are reference values.

Monitor item	Condition	Specification
Torque converter clutch solenoid valve duty	Lock-up OFF	Approximately 4%
	↓ Lock-up ON	↓ Approximately 94%

On Board Diagnosis Logic

ECS006C8

Diagnostic trouble code TCC SOLENOID/CIRC with CONSULT-II or P0740 without CONSULT-II is detected when TCM detects an improper voltage drop when it tries to operate the solenoid valve.

Possible Cause

ECS006C9

Check the following items.

- Torque converter clutch solenoid valve
- Harness or connectors
(The solenoid circuit is open or shorted.)

Diagnostic Trouble Code (DTC) Confirmation Procedure

ECS006CA

NOTE:

If "DTC Confirmation Procedure" has been previously conducted, always turn ignition switch OFF and wait at least 10 seconds before conducting the next test.

After the repair, perform the following procedure to confirm the malfunction is eliminated.

WITH CONSULT-II

1. Turn ignition switch ON.

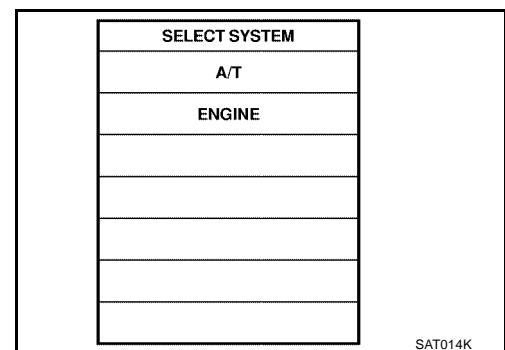

DTC P0740 TORQUE CONVERTER CLUTCH SOLENOID VALVE

2. Select "DATA MONITOR" mode for "ENGINE" with CONSULT-II and wait at least 1 second.

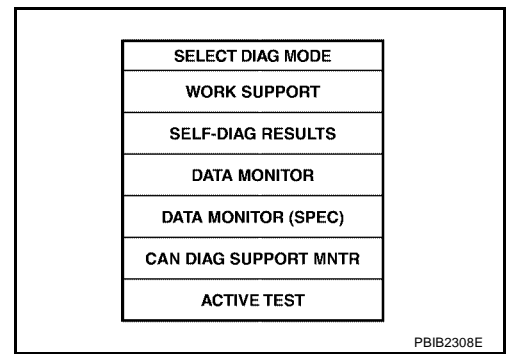

WITH GST

Follow the procedure "With CONSULT-II".

A
B
AT
D
E
F
G
H
I
J
K
L
M

DTC P0740 TORQUE CONVERTER CLUTCH SOLENOID VALVE

Wiring Diagram — AT — TCV

ECS006CB

AT-TCV-01

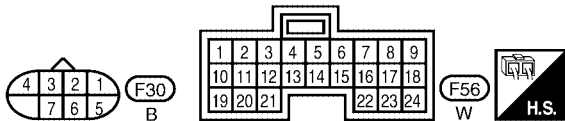
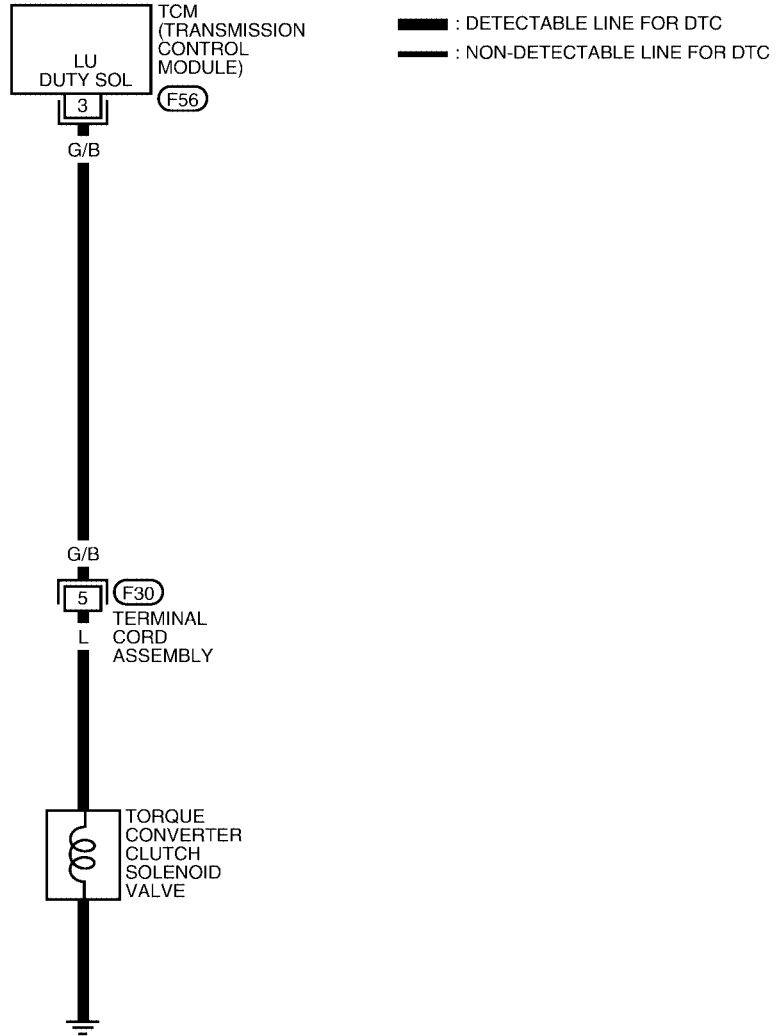

LCWA0014E

DTC P0740 TORQUE CONVERTER CLUTCH SOLENOID VALVE

TCM TERMINALS AND REFERENCE VALUE MEASURED BETWEEN EACH TERMINAL AND 25 OR 48 (TCM GROUND)

TERMINAL	WIRE COLOR	ITEM	CONDITION	DATA (APPROX.)
3	G/B	TORQUE CONVERTER CLUTCH SOLENOID VALVE	WITH TORQUE CONVERTER LOCK-UP	8 - 15V
			WITHOUT TORQUE CONVERTER LOCK-UP	0V

Diagnostic Procedure

ECS006CC

1. CHECK VALVE RESISTANCE

- Turn ignition switch to OFF position.
- Disconnect terminal cord assembly connector in engine compartment.
- Check resistance between terminal 5 and ground.

Resistance : 5 - 20Ω

OK or NG

- OK >> GO TO 3.
NG >> GO TO 2.

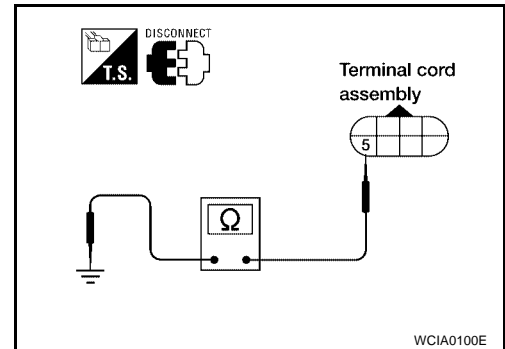

2. CHECK VALVE OPERATION

- Remove oil pan.
- Check the following items:
 - Torque converter clutch solenoid valve
 - Check solenoid valve by listening for its operating sound while applying battery voltage to the terminal and ground.
 - Harness of terminal cord assembly for short or open

OK or NG

- OK >> GO TO 3.
NG >> Repair or replace damaged parts.

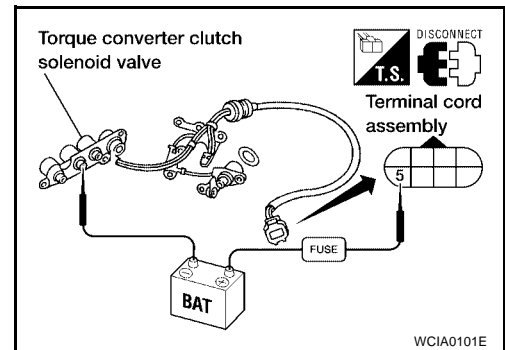

3. CHECK POWER SOURCE CIRCUIT

- Turn ignition switch to OFF position.
- Disconnect TCM harness connector.
- Check continuity between terminal cord assembly harness connector terminal 5 and TCM harness connector terminal 3. Refer to [AT-148, "Wiring Diagram — AT — TCV"](#).

Continuity should exist.

- Reinstall any part removed.

OK or NG

- OK >> GO TO 4.
NG >> Repair open circuit or short to ground or short to power in harness or connectors.

DTC P0740 TORQUE CONVERTER CLUTCH SOLENOID VALVE

4. CHECK DTC

Perform [AT-146, "Diagnostic Trouble Code \(DTC\) Confirmation Procedure"](#) .

OK or NG

OK >> **INSPECTION END**
NG >> GO TO 5.

5. CHECK TCM INSPECTION

1. Perform TCM input/output signal inspection.
2. If NG, recheck TCM pin terminals for damage or loose connection with harness connector.

OK or NG

OK >> **INSPECTION END**
NG >> Repair or replace damaged parts.

DTC P0744 A/T TCC S/V FUNCTION (LOCK-UP)

DTC P0744 A/T TCC S/V FUNCTION (LOCK-UP)

PDF:31940

Description

ECS006CD

- This is an OBD-II self-diagnostic item and not available in TCM self-diagnosis.
- This malfunction will not be detected while the A/T check position indicator lamp is indicating another self-diagnosis malfunction.
- This malfunction is detected when the A/T does not shift into fourth gear position or the torque converter clutch does not lock up as instructed by the TCM. This is not caused by electrical malfunction (circuits open or shorted) but by mechanical malfunction such as control valve sticking, improper solenoid valve operation, malfunctioning oil pump or torque converter clutch, etc.

CONSULT-II REFERENCE VALUE IN DATA MONITOR MODE

Remarks: Specification data are reference values.

Monitor item	Condition	Specification
Torque converter clutch solenoid valve duty	Lock-up OFF	Approximately 4%
	↓ Lock-up ON	↓ Approximately 94%

On Board Diagnosis Logic

ECS006CE

This diagnosis monitors actual gear position by checking the torque converter slip ratio calculated by TCM as follows:

Torque converter slip ratio = A x C/B

A: Output shaft revolution signal from revolution sensor

B: Engine speed signal from ECM

C: Gear ratio determined as gear position which TCM supposes

If the actual gear position is much lower than the position (4th) supposed by TCM, the slip ratio will be much less than normal. In case the ratio does not reach the specified value, TCM judges this diagnosis malfunction. This malfunction will be caused when shift solenoid valve B is stuck closed.

Gear positions supposed by TCM are as follows.

In case of gear position with no malfunctions: 1, 2, 3 and 4 positions

In case of gear position with shift solenoid valve B stuck closed: 1, 2, 2 and 1* positions to each gear position above

*: P0744 is detected.

Diagnostic trouble code A/T TCC S/V FNCTN with CONSULT-II or P0744 without CONSULT-II is detected when A/T cannot perform lock-up even if electrical circuit is good.

Possible Cause

ECS006CF

Check the following items.

- Line pressure solenoid valve
- Torque converter clutch solenoid valve
- Each clutch
- Hydraulic control circuit

Diagnostic Trouble Code (DTC) Confirmation Procedure

ECS006CG

CAUTION:

Always drive vehicle at a safe speed.

NOTE:

If "DTC Confirmation Procedure" has been previously conducted, always turn ignition switch OFF and wait at least 10 seconds before conducting the next test.

After the repair, perform the following procedure to confirm the malfunction is eliminated.

DTC P0744 A/T TCC S/V FUNCTION (LOCK-UP)

WITH CONSULT-II

1. Start engine and select "DATA MONITOR" mode for "A/T" with CONSULT-II.
2. Make sure that output voltage of A/T fluid temperature sensor is within the range below.
FLUID TEMP SEN: 0.4 - 1.5V
If out of range, drive vehicle to decrease voltage (warm up the fluid) or stop engine to increase voltage (cool down the fluid).
3. Select "TCC S/V FNCTN P0744" of "DTC WORK SUPPORT" mode for "A/T" with CONSULT-II and touch "START".

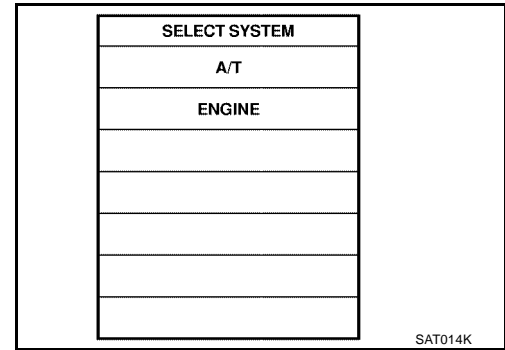

4. Accelerate vehicle to more than 80 km/h (50 MPH) and maintain the following condition continuously until "TESTING" has turned to "COMPLETE". (It will take approximately 30 seconds after "TESTING" shows.)

THROTTLE POSI: 1.0/8 - 2.0/8 (at all times during step 4)

Selector lever: D position

TCC S/V DUTY: More than 94%

VHCL/S SE-A/T: Constant speed of more than 80 km/h (50 MPH)

- Check that "GEAR" shows "4".
 - For shift schedule, refer to [AT-373, "Shift Schedule"](#).
 - If "TESTING" does not appear on CONSULT-II for a long time, select "SELF-DIAG RESULTS". In case a 1st trip DTC other than P0744 is shown, refer to applicable "TROUBLE DIAGNOSIS FOR DTC".
5. Make sure that "OK" is displayed. (If "NG" is displayed, refer to "DIAGNOSTIC PROCEDURE".)
Refer to [AT-154, "Diagnostic Procedure"](#).
Refer to [AT-373, "Shift Schedule"](#).

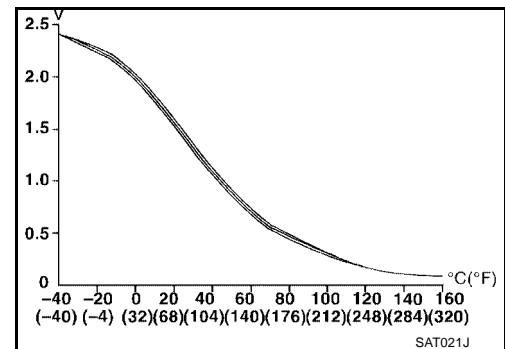
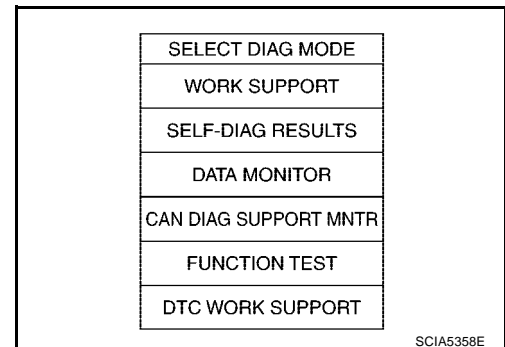

WITH GST

Follow the procedure "With CONSULT-II".

DTC P0744 A/T TCC S/V FUNCTION (LOCK-UP)

Wiring Diagram — AT — TCCSIG

ECS006CH

AT-TCCSIG-01

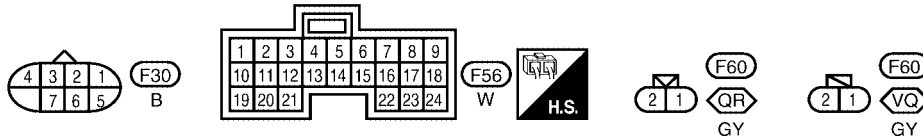
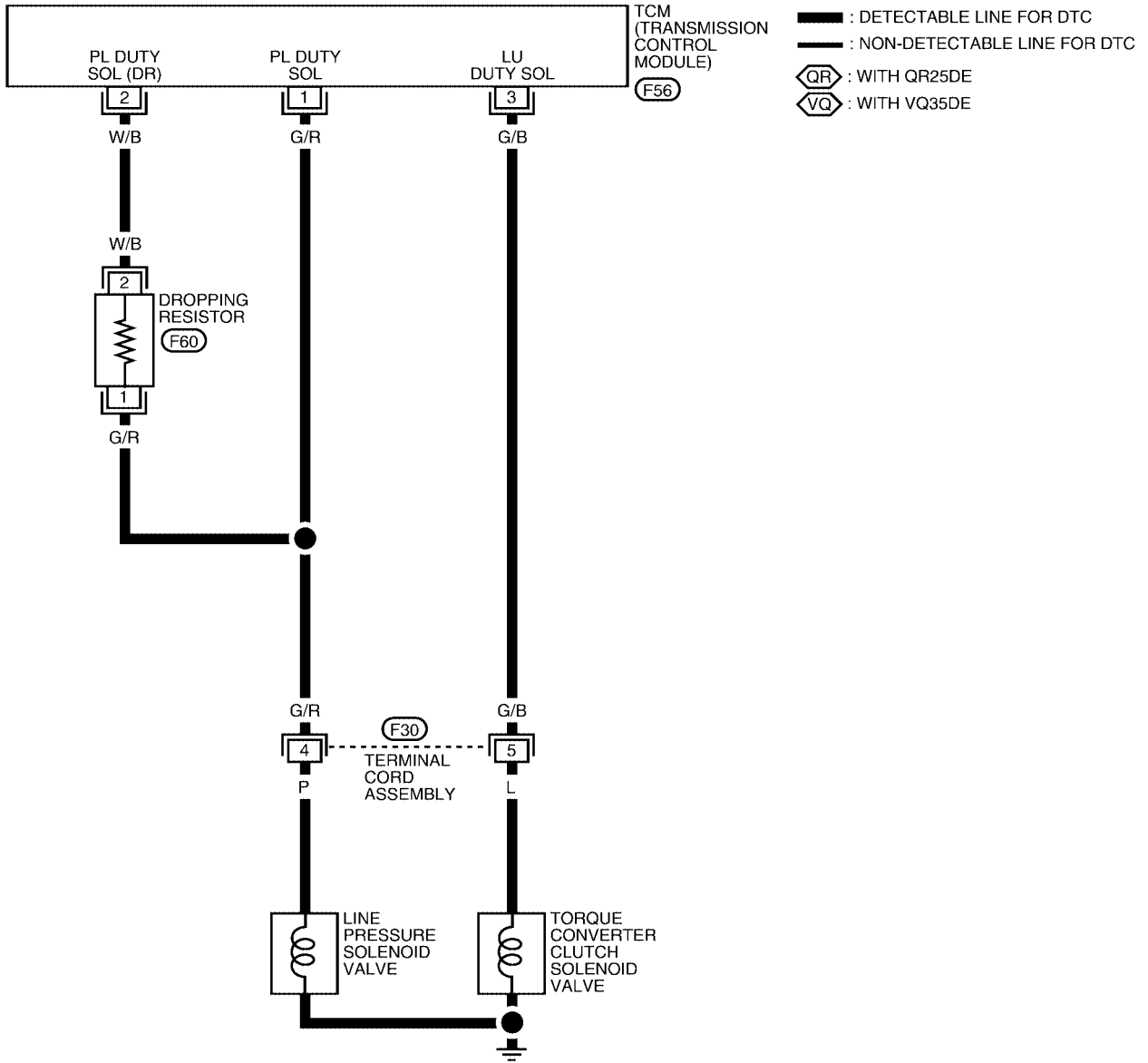

WCWA0051E

DTC P0744 A/T TCC S/V FUNCTION (LOCK-UP)

TCM TERMINALS AND REFERENCE VALUE MEASURED BETWEEN EACH TERMINAL AND 25 OR 48 (TCM GROUND)

TERMINAL	WIRE COLOR	ITEM	CONDITION	DATA (APPROX.)
1	G/R	LINE PRESSURE SOLENOID VALVE	WHEN ACCELERATOR PEDAL IS RELEASED WHILE DRIVING	1.5 - 3.0V
			WHEN ACCELERATOR PEDAL IS DEPRESSED WHILE DRIVING	0V
2	W/B	LINE PRESSURE SOLENOID VALVE (DROPPING RESISTOR)	WHEN ACCELERATOR PEDAL IS RELEASED WHILE DRIVING	4 - 14V
			WHEN ACCELERATOR PEDAL IS DEPRESSED WHILE DRIVING	0V
3	G/B	TORQUE CONVERTER CLUTCH SOLENOID VALVE	WITH TORQUE CONVERTER LOCK-UP	8 - 15V
			WITHOUT TORQUE CONVERTER LOCK-UP	0V

Diagnostic Procedure

ECS006C1

1. CHECK SHIFT UP (D3 TO D4)

During [AT-75, "Cruise Test — Part 1"](#), does A/T shift from D3 to D4 at the specified speed?

Yes or No

Yes >> GO TO 11.

No >> GO TO 2.

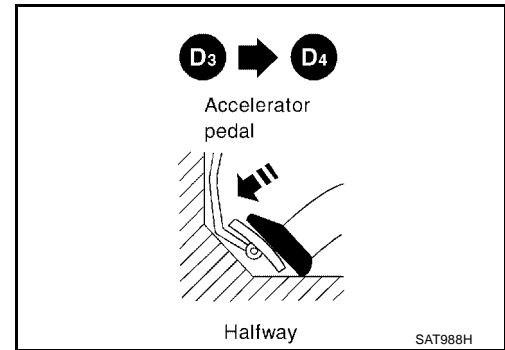

2. CHECK LINE PRESSURE

Perform line pressure test.

Engine Speed RPM	Line Pressure kPa (kg/cm ² , psi)			
	QR25DE		VQ35DE	
	D, 2 and 1 Position	R Position	D, 2 and 1 Position	R Position
Idle	500 (5.1, 73)	778 (7.9, 113)	500 (5.1, 73)	778 (7.9, 113)
Stall	1.233 (12.6, 179)	1.918 (19.6, 278)	1.233 (12.6, 179)	1.918 (19.6, 278)

Refer to [AT-65, "Line Pressure Test"](#).

OK or NG

OK >> GO TO 3.

NG >> GO TO 6.

DTC P0744 A/T TCC S/V FUNCTION (LOCK-UP)

3. CHECK CONTROL VALVE

1. Disassemble control valve assembly. Refer to [AT-299, "Control Valve Assembly"](#) .
2. Check to ensure that:
 - Valve, sleeve and plug slide along valve bore under their own weight.
 - Valve, sleeve and plug are free from burrs, dents and scratches.
 - Control valve springs are free from damage, deformation and fatigue.
 - Hydraulic line is free from obstacles.

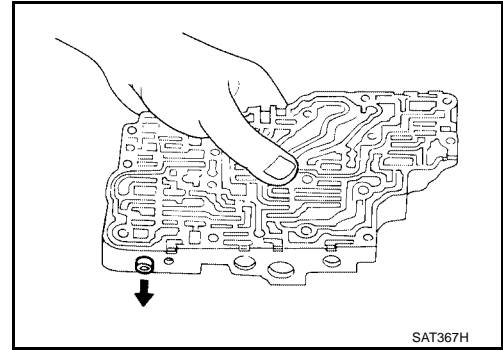

OK or NG

- OK >> GO TO 4.
- NG >> Repair control valve.

4. CHECK SHIFT UP (D₃ TO D₄)

Does A/T shift from D₃ to D₄ at the specified speed?

OK or NG

- OK >> GO TO 5.
- NG >> Check control valve again. Repair or replace control valve assembly.

5. CHECK DTC

Perform [AT-151, "Diagnostic Trouble Code \(DTC\) Confirmation Procedure"](#) .

OK or NG

- OK >> **INSPECTION END**
- NG >> GO TO 11. Check for proper lock-up.

6. CHECK VALVE RESISTANCE

1. Remove control valve assembly. Refer to [AT-264, "Control Valve Assembly and Accumulators"](#) .
 - Line pressure solenoid valve
2. Check resistance to the terminal and ground.

Solenoid valve	Terminal No.		Resistance (Approx.)
Line pressure solenoid valve	4	Ground	2.5 - 5Ω

OK or NG

- OK >> GO TO 8.
- NG >> Replace solenoid valve assembly.

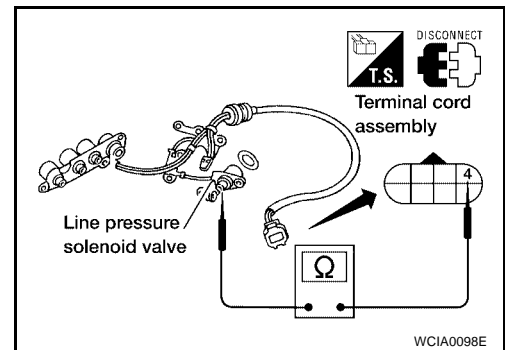

DTC P0744 A/T TCC S/V FUNCTION (LOCK-UP)

7. CHECK VALVE OPERATION

1. Remove control valve assembly. Refer to [AT-264, "Control Valve Assembly and Accumulators"](#) .
 - Line pressure solenoid valve
2. Check solenoid valve by listening for its operating sound while applying battery voltage to the terminal and ground.

OK or NG

- OK >> GO TO 8.
- NG >> Replace solenoid valve assembly.

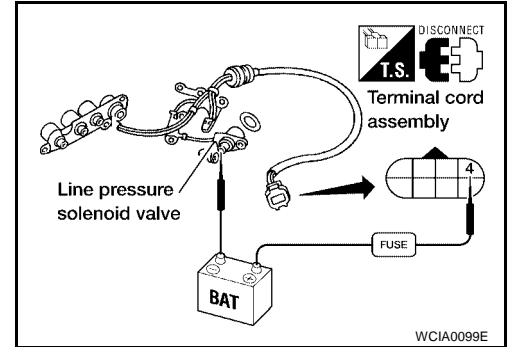

8. CHECK CONTROL VALVE

1. Disassemble control valve assembly. Refer to [AT-299, "Control Valve Assembly"](#) .
2. Check line pressure circuit valves for sticking.
 - Pressure regulator valve
 - Pilot valve
 - Pressure modifier valve

OK or NG

- OK >> GO TO 9.
- NG >> Repair control valve.

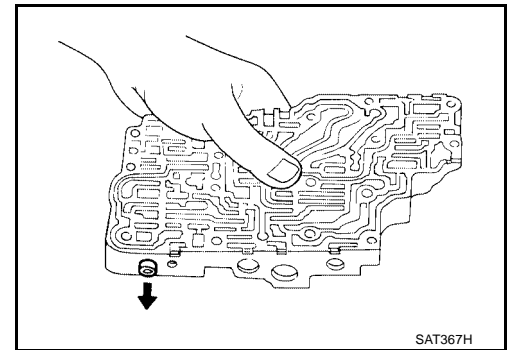

9. CHECK SHIFT UP (D3 TO D4)

Does A/T shift from D3 to D4 at the specified speed?

OK or NG

- OK >> GO TO 10.
- NG >> Check control valve again. Repair or replace control valve assembly.

10. CHECK DTC

Perform [AT-151, "Diagnostic Trouble Code \(DTC\) Confirmation Procedure"](#) .

OK or NG

- OK >> **INSPECTION END**
- NG >> GO TO 11. Check for proper lock-up.

11. CHECK LOCK-UP

During [AT-75, "Cruise Test — Part 1"](#) , does A/T perform lock-up at the specified speed?

Yes or No

- Yes >> Perform "Cruise test — Part 1" again and return to the start point of this test group.
- No >> GO TO 12.

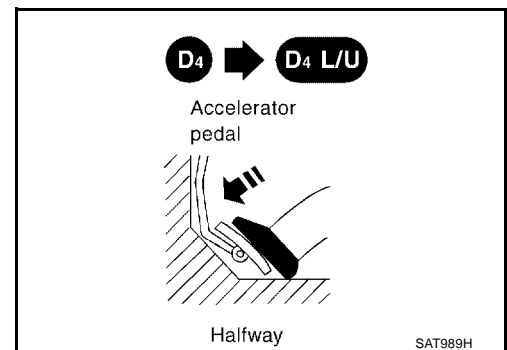

DTC P0744 A/T TCC S/V FUNCTION (LOCK-UP)

12. CHECK VALVE RESISTANCE

1. Remove control valve assembly. Refer to [AT-264, "Control Valve Assembly and Accumulators"](#) .
 - Torque converter clutch solenoid valve
2. Check resistance to the terminal and ground.

Solenoid valve	Terminal No.		Resistance (Approx.)
Torque converter clutch solenoid valve	5	Ground	5 - 20Ω

OK or NG

- OK >> GO TO 14.
- NG >> Replace solenoid valve assembly.

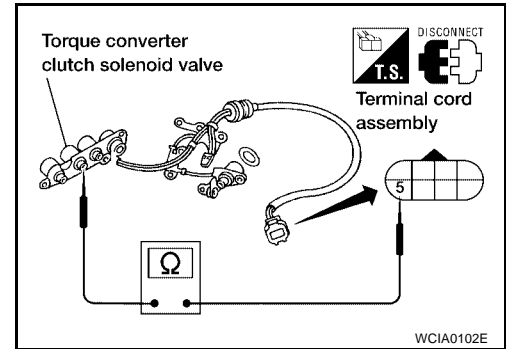

13. CHECK VALVE OPERATION

1. Remove control valve assembly. Refer to [AT-264, "Control Valve Assembly and Accumulators"](#) .
 - Torque converter clutch solenoid valve
2. Check solenoid valve by listening for its operating sound while applying battery voltage to the terminal and ground.

OK or NG

- OK >> GO TO 14.
- NG >> Replace solenoid valve assembly.

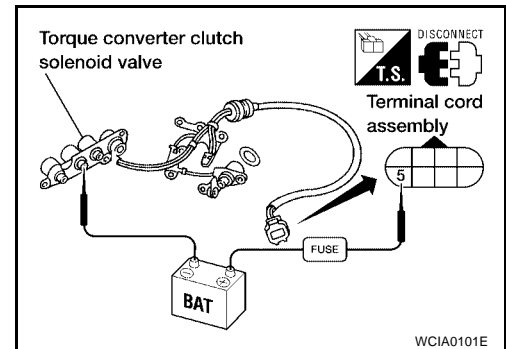

14. CHECK CONTROL VALVE

1. Disassemble control valve assembly. Refer to [AT-299, "Control Valve Assembly"](#) .
2. Check control valves for sticking.
 - Torque converter clutch control valve
 - Torque converter clutch relief valve

OK or NG

- OK >> GO TO 15.
- NG >> Repair control valve.

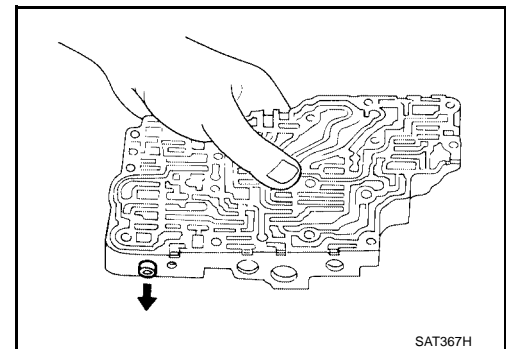

15. CHECK LOCK-UP

Does A/T perform lock-up at the specified speed?

Yes or No

- Yes >> GO TO 16.
- No >> Check control valve again. Repair or replace control valve assembly.

DTC P0744 A/T TCC S/V FUNCTION (LOCK-UP)

16. CHECK DTC

Perform [AT-151, "Diagnostic Trouble Code \(DTC\) Confirmation Procedure"](#) .

OK or NG

OK >> **INSPECTION END**

NG >> Perform "Cruise test — Part 1" again and return to the start point of this test group.

DTC P0745 LINE PRESSURE SOLENOID VALVE

DTC P0745 LINE PRESSURE SOLENOID VALVE

PF3:31940

ECS006CJ

Description

The line pressure solenoid valve regulates the oil pump discharge pressure to suit the driving condition in response to a signal sent from the TCM.

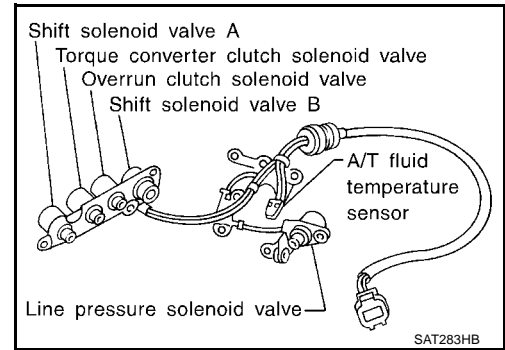

CONSULT-II REFERENCE VALUE IN DATA MONITOR MODE

Remarks: Specification data are reference values.

Monitor item	Condition	Specification
Line pressure solenoid valve duty	Small throttle opening (Low line pressure)	Approximately 24%
	↓ Large throttle opening (High line pressure)	↓ Approximately 95%

On Board Diagnosis Logic

ECS006CK

Diagnostic trouble code L/PRESS SOL/CIRC with CONSULT-II or P0745 without CONSULT-II is detected when TCM detects an improper voltage drop when it tries to operate the solenoid valve.

Possible Cause

ECS006CL

Check the following items.

- Harness or connectors
(The solenoid circuit is open or shorted.)
- Line pressure solenoid valve

Diagnostic Trouble Code (DTC) Confirmation Procedure

ECS006CM

NOTE:

If "DTC Confirmation Procedure" has been previously conducted, always turn ignition switch OFF and wait at least 10 seconds before conducting the next test.

After the repair, perform the following procedure to confirm the malfunction is eliminated.

WITH CONSULT-II

1. Turn ignition switch ON and select "DATA MONITOR" mode for "ENGINE" with CONSULT-II.

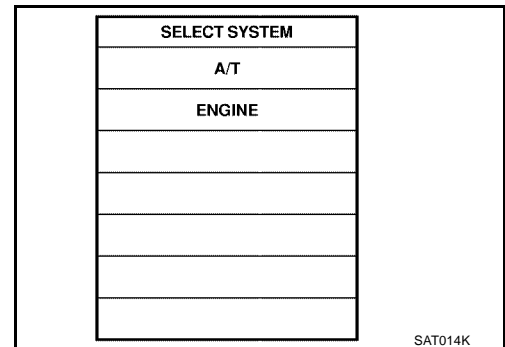

DTC P0745 LINE PRESSURE SOLENOID VALVE

- Depress accelerator pedal completely and wait at least 1 second.

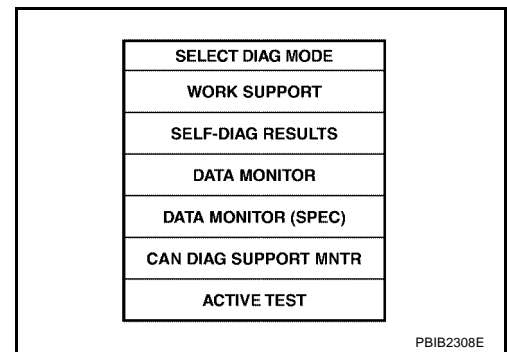

WITH GST

Follow the procedure "With CONSULT-II".

DTC P0745 LINE PRESSURE SOLENOID VALVE

Wiring Diagram — AT — LPSV

ECS006CN

AT-LPSV-01

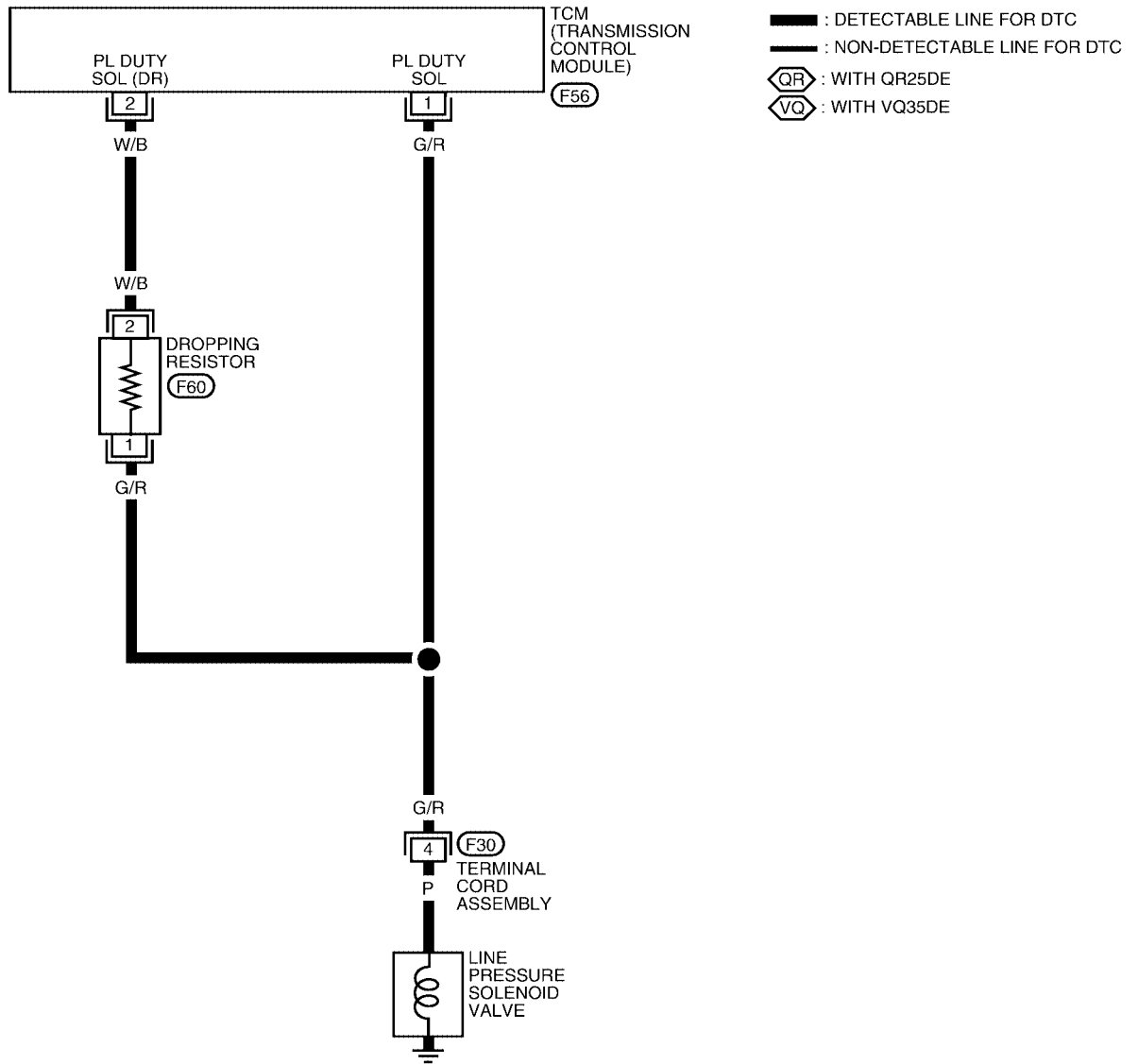

A
B
AT
D
E
F
G
H
I
J
K
L
M

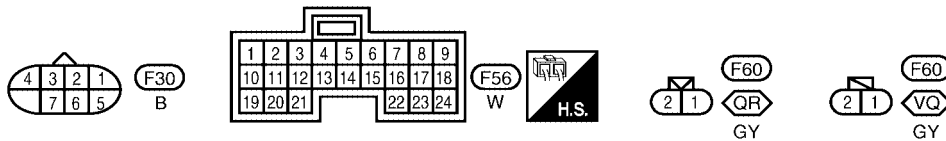

WCWA0052E

DTC P0745 LINE PRESSURE SOLENOID VALVE

TCM TERMINALS AND REFERENCE VALUE MEASURED BETWEEN EACH TERMINAL AND 25 OR 48 (TCM GROUND)

TERMINAL	WIRE COLOR	ITEM	CONDITION	DATA (APPROX.)
1	G/R	LINE PRESSURE SOLENOID VALVE	WHEN ACCELERATOR PEDAL IS RELEASED WHILE DRIVING	1.5 - 3.0V
			WHEN ACCELERATOR PEDAL IS DEPRESSED WHILE DRIVING	0V
2	W/B	LINE PRESSURE SOLENOID VALVE (DROPPING RESISTOR)	WHEN ACCELERATOR PEDAL IS RELEASED WHILE DRIVING	4 - 14V
			WHEN ACCELERATOR PEDAL IS DEPRESSED WHILE DRIVING	0V

Diagnostic Procedure

ECS006CO

1. CHECK VALVE RESISTANCE

1. Turn ignition switch to OFF position.
2. Disconnect terminal cord assembly connector in engine compartment.
3. Check resistance between terminal cord assembly harness connector terminal 4 and ground.

Resistance : 2.5 - 5Ω

OK or NG

- OK >> GO TO 3.
 NG >> GO TO 2.

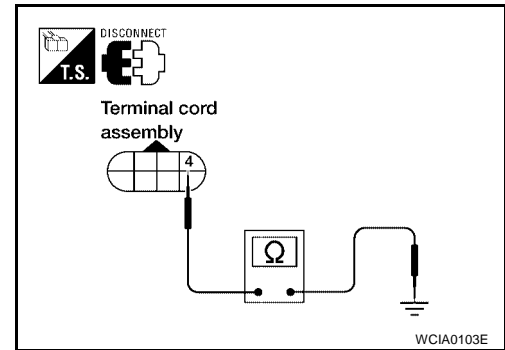

2. CHECK VALVE OPERATION

1. Remove control valve assembly. Refer to [AT-264, "Control Valve Assembly and Accumulators"](#).
2. Check the following items:
 - Line pressure solenoid valve
 - Check solenoid valve by listening for its operating sound while applying battery voltage to the terminal and ground.
 - Harness of terminal cord assembly for short or open

OK or NG

- OK >> GO TO 3.
 NG >> Repair or replace damaged parts.

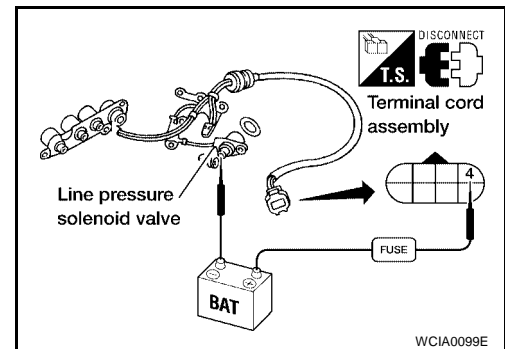

DTC P0745 LINE PRESSURE SOLENOID VALVE

3. CHECK POWER SOURCE AND DROPPING RESISTOR CIRCUIT

1. Turn ignition switch to OFF position.
2. Disconnect TCM harness connector.
3. Check resistance between terminal 4 (G/R) and TCM harness connector terminal 2 (W/B).

Resistance : 10 - 15Ω

OK or NG

- OK >> GO TO 5.
- NG >> GO TO 4.

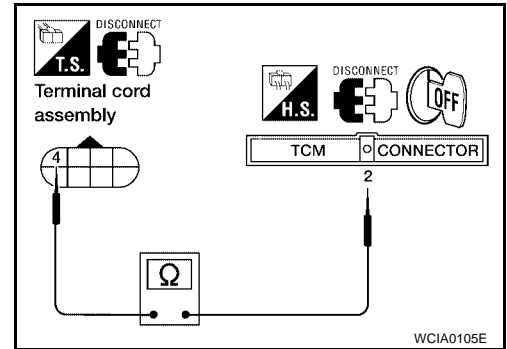

4. DETECT MALFUNCTIONING ITEM

Check the following items:

- Dropping resistor
- Check resistance between two terminals.

Resistance : 10 - 15Ω

- Harness for short or open between TCM terminal 2 and terminal cord assembly (Main harness)

OK or NG

- OK >> GO TO 5.
- NG >> Repair or replace damaged parts.

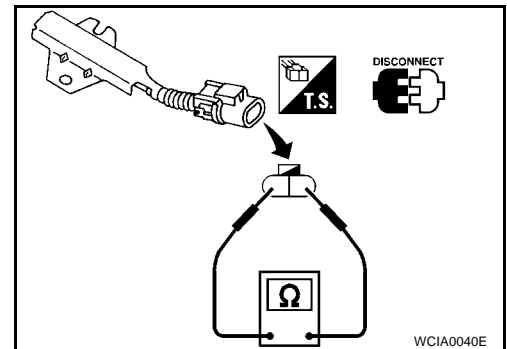

5. CHECK POWER SOURCE CIRCUIT

1. Turn ignition switch to OFF position.
2. Check continuity between terminal cord assembly harness connector terminal 4 and TCM harness connector terminal 1. Refer to [AT-161, "Wiring Diagram — AT — LPSV"](#).

Continuity should exist.

3. Reinstall any part removed.

OK or NG

- OK >> GO TO 6.
- NG >> Repair open circuit or short to ground or short to power in harness or connectors.

6. CHECK DTC

Perform [AT-159, "Diagnostic Trouble Code \(DTC\) Confirmation Procedure"](#).

OK or NG

- OK >> **INSPECTION END**
- NG >> GO TO 7.

DTC P0745 LINE PRESSURE SOLENOID VALVE

7. CHECK TCM INSPECTION

1. Perform TCM input/output signal inspection.
2. If NG, recheck TCM pin terminals for damage or loose connection with harness connector.

OK or NG

- OK >> **INSPECTION END**
NG >> Repair or replace damaged parts.

DTC P0750 SHIFT SOLENOID VALVE A

DTC P0750 SHIFT SOLENOID VALVE A

PF31940

Description

ECS006CP

Shift solenoid valves A and B are turned ON or OFF by the TCM in response to signals sent from the park/neutral position (PNP) switch, vehicle speed and ECM (throttle opening). Gears will then be shifted to the optimum position.

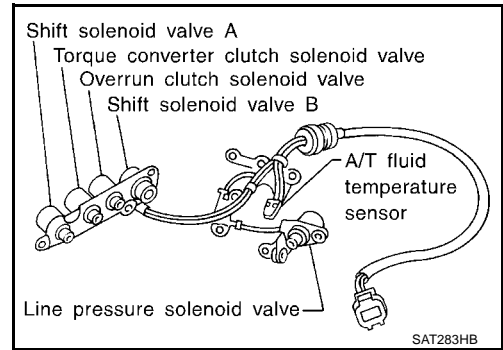

Gear position	1	2	3	4
Shift solenoid valve A	ON (Closed)	OFF (Open)	OFF (Open)	ON (Closed)
Shift solenoid valve B	ON (Closed)	ON (Closed)	OFF (Open)	OFF (Open)

On Board Diagnosis Logic

ECS006CQ

Diagnostic trouble code SFT SOL A/CIRC with CONSULT-II or P0750 without CONSULT-II is detected when TCM detects an improper voltage drop when it tries to operate the solenoid valve.

Possible Cause

ECS006CR

Check the following items.

- Harness or connectors
(The solenoid circuit is open or shorted.)
- Shift solenoid valve A

Diagnostic Trouble Code (DTC) Confirmation Procedure

ECS006CS

CAUTION:

Always drive vehicle at a safe speed.

NOTE:

If "DTC Confirmation Procedure" has been previously conducted, always turn ignition switch OFF and wait at least 10 seconds before conducting the next test.

After the repair, perform the following procedure to confirm the malfunction is eliminated.

WITH CONSULT-II

1. Turn ignition switch ON and select "DATA MONITOR" mode for "ENGINE" with CONSULT-II.

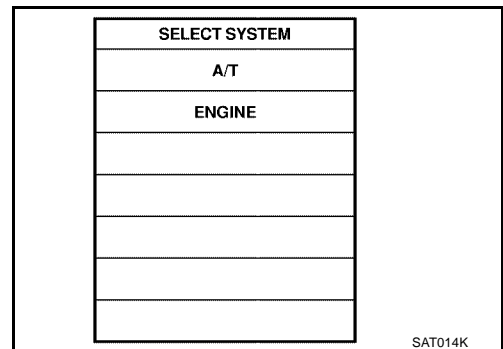

SAT014K

DTC P0750 SHIFT SOLENOID VALVE A

2. Start engine.
3. Drive vehicle in D position and allow the transmission to shift 1 → 2 (“GEAR”).

SELECT DIAG MODE
WORK SUPPORT
SELF-DIAG RESULTS
DATA MONITOR
DATA MONITOR (SPEC)
CAN DIAG SUPPORT MNTR
ACTIVE TEST

PBIB2308E

WITH GST

Follow the procedure “With CONSULT-II”.

DTC P0750 SHIFT SOLENOID VALVE A

Wiring Diagram — AT — SSV/A

ECS006CT

AT-SSV/A-01

A
B
AT
D
E
F
G
H
I
J
K
L
M

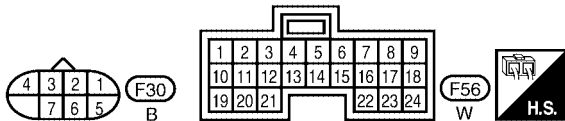
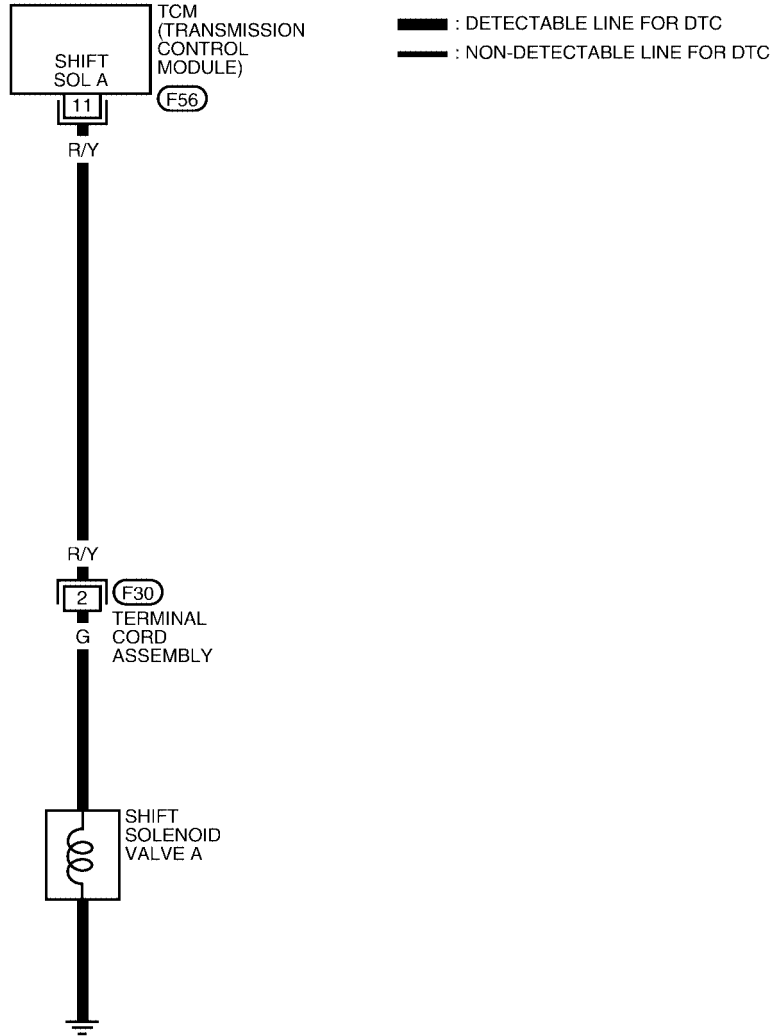

LCWA0017E

DTC P0750 SHIFT SOLENOID VALVE A

TCM TERMINALS AND REFERENCE VALUE MEASURED BETWEEN EACH TERMINAL AND 25 OR 48 (TCM GROUND)

TERMINAL	WIRE COLOR	ITEM	CONDITION	DATA (APPROX.)
11	R/Y	SHIFT SOLENOID VALVE A	WHEN SHIFT SOLENOID VALVE A IS OPERATING (DRIVING IN D1 OR D4)	BATTERY VOLTAGE
			WHEN SHIFT SOLENOID VALVE A IS NOT OPERATING (DRIVING IN D2 OR D3)	0V

Diagnostic Procedure

ECS006CU

1. CHECK VALVE RESISTANCE

- Turn ignition switch to OFF position.
- Disconnect terminal cord assembly connector in engine compartment.
- Check resistance between terminal cord assembly harness connector terminal 2 and ground.

Resistance : 20 - 30Ω

OK or NG

- OK >> GO TO 3.
NG >> GO TO 2.

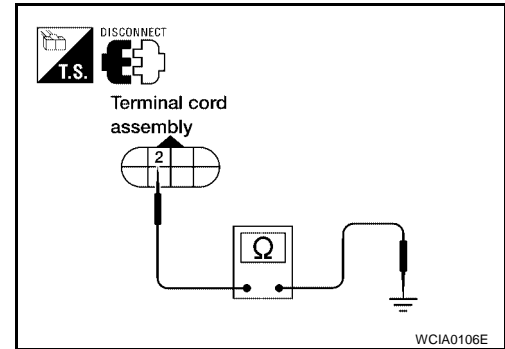

2. CHECK VALVE OPERATION

- Remove control valve assembly. Refer to [AT-264, "Control Valve Assembly and Accumulators"](#).
- Check the following items:
 - Shift solenoid valve A
 - Operation check
 - Check solenoid valve by listening for its operating sound while applying battery voltage to the terminal and ground.
 - Harness of terminal cord assembly for short or open

OK or NG

- OK >> GO TO 3.
NG >> Repair or replace damaged parts.

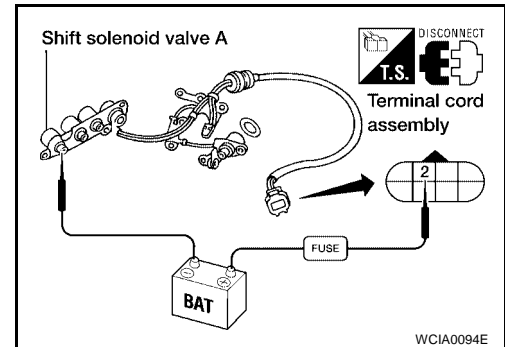

3. CHECK POWER SOURCE CIRCUIT

- Turn ignition switch to OFF position.
- Disconnect TCM harness connector.
- Check continuity between terminal cord assembly harness connector terminal 2 and TCM harness connector terminal 11. Refer to [AT-167, "Wiring Diagram — AT — SSV/A"](#).

Continuity should exist.

- Reinstall any part removed.

OK or NG

- OK >> GO TO 4.
NG >> Repair open circuit or short to ground or short to power in harness or connectors.

DTC P0750 SHIFT SOLENOID VALVE A

4. CHECK DTC

Perform [AT-165, "Diagnostic Trouble Code \(DTC\) Confirmation Procedure"](#) .

OK or NG

OK >> **INSPECTION END**
NG >> GO TO 5.

5. CHECK TCM INSPECTION

1. Perform TCM input/output signal inspection.
2. If NG, recheck TCM pin terminals for damage or loose connection with harness connector.

OK or NG

OK >> **INSPECTION END**
NG >> Repair or replace damaged parts.

A

B

AT

D

E

F

G

H

I

J

K

L

M

DTC P0755 SHIFT SOLENOID VALVE B

DTC P0755 SHIFT SOLENOID VALVE B

PFP:31940

Description

ECS006CV

Shift solenoid valves A and B are turned ON or OFF by the TCM in response to signals sent from the park/neutral position (PNP) switch, vehicle speed and ECM (throttle opening). Gears will then be shifted to the optimum position.

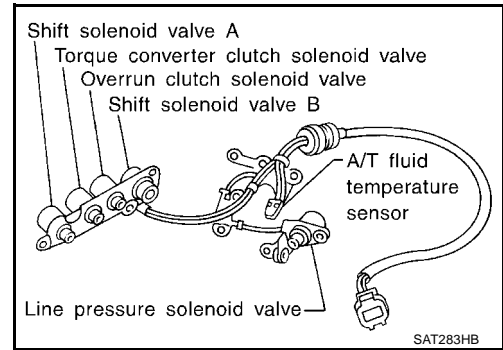

Gear position	1	2	3	4
Shift solenoid valve A	ON (Closed)	OFF (Open)	OFF (Open)	ON (Closed)
Shift solenoid valve B	ON (Closed)	ON (Closed)	OFF (Open)	OFF (Open)

On Board Diagnosis Logic

ECS006CW

Diagnostic trouble code SFT SOL B/CIRC with CONSULT-II or P0755 without CONSULT-II is detected when TCM detects an improper voltage drop when it tries to operate the solenoid valve.

Possible Cause

ECS006CX

Check the following items.

- Harness or connectors
(The solenoid circuit is open or shorted.)
- Shift solenoid valve B

Diagnostic Trouble Code (DTC) Confirmation Procedure

ECS006CY

CAUTION:

Always drive vehicle at a safe speed.

NOTE:

If "DTC Confirmation Procedure" has been previously conducted, always turn ignition switch OFF and wait at least 10 seconds before conducting the next test.

After the repair, perform the following procedure to confirm the malfunction is eliminated.

WITH CONSULT-II

1. Turn ignition switch ON and select "DATA MONITOR" mode for "ENGINE" with CONSULT-II.

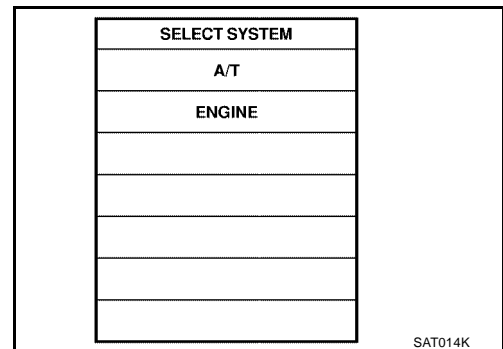

SAT014K

DTC P0755 SHIFT SOLENOID VALVE B

2. Start engine.
3. Drive vehicle in D position and allow the transmission to shift 1 → 2 → 3 (“GEAR”).

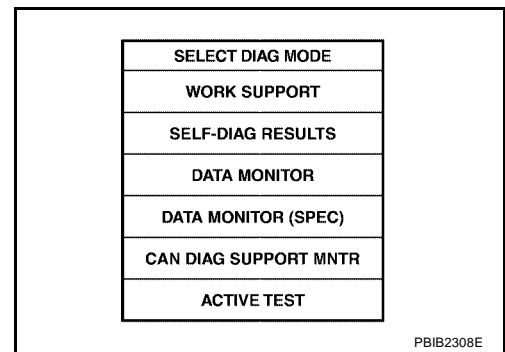

WITH GST

Follow the procedure “With CONSULT-II”.

DTC P0755 SHIFT SOLENOID VALVE B

Wiring Diagram — AT — SSV/B

ECS006CZ

AT-SSV/B-01

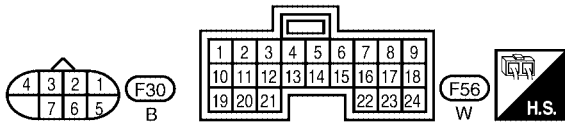
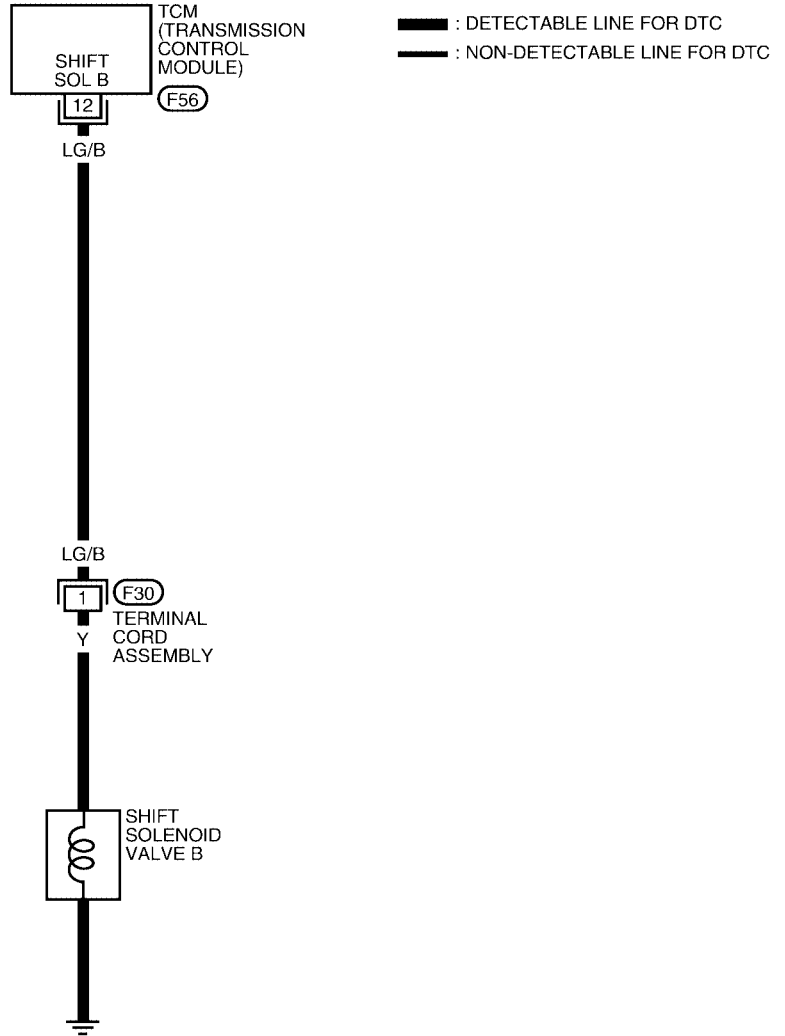

LCWA0018E

DTC P0755 SHIFT SOLENOID VALVE B

TCM TERMINALS AND REFERENCE VALUE MEASURED BETWEEN EACH TERMINAL AND 25 OR 48 (TCM GROUND)

TERMINAL	WIRE COLOR	ITEM	CONDITION	DATA (APPROX.)
12	LG/B	SHIFT SOLENOID VALVE B	WHEN SHIFT SOLENOID VALVE B IS OPERATING (DRIVING IN D1 OR D2)	BATTERY VOLTAGE
			WHEN SHIFT SOLENOID VALVE BE IS NOT OPERATING (DRIVING IN D3 OR D4)	0V

Diagnostic Procedure

ECS006D0

1. CHECK VALVE RESISTANCE

- Turn ignition switch to OFF position.
- Disconnect terminal cord assembly connector in engine compartment.
- Check resistance between terminal cord assembly harness connector terminal 1 and ground.

Resistance : 5 - 20Ω

OK or NG

- OK >> GO TO 3.
NG >> GO TO 2.

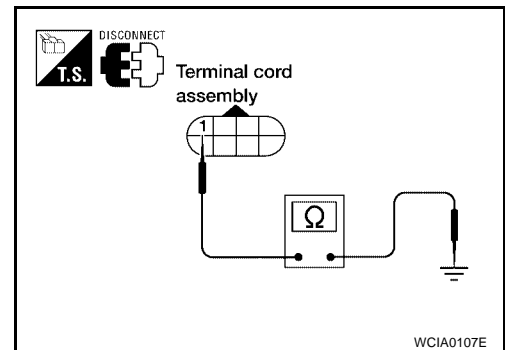

2. CHECK VALVE OPERATION

- Remove control valve assembly. Refer to [AT-264, "Control Valve Assembly and Accumulators"](#).
- Check the following items:
 - Shift solenoid valve B
 - Operation check
 - Check solenoid valve by listening for its operating sound while applying battery voltage to the terminal and ground.
 - Harness of terminal cord assembly for short or open

OK or NG

- OK >> GO TO 3.
NG >> Repair or replace damaged parts.

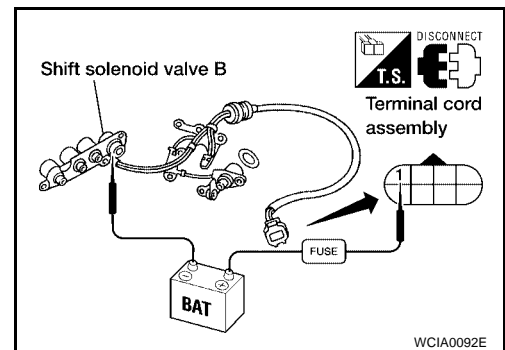

3. CHECK POWER SOURCE CIRCUIT

- Turn ignition switch to OFF position.
- Disconnect TCM harness connector.
- Check continuity between terminal cord harness connector terminal 1 and TCM harness connector terminal 12. Refer to [AT-172, "Wiring Diagram — AT — SSV/B"](#).

Continuity should exist.

- Reinstall any part removed.

OK or NG

- OK >> GO TO 4.
NG >> Repair open circuit or short to ground or short to power in harness or connectors.

DTC P0755 SHIFT SOLENOID VALVE B

4. CHECK DTC

Perform [AT-170, "Diagnostic Trouble Code \(DTC\) Confirmation Procedure"](#) .

OK or NG

OK >> **INSPECTION END**
NG >> GO TO 5.

5. CHECK TCM INSPECTION

1. Perform TCM input/output signal inspection.
2. If NG, recheck TCM pin terminals for damage or loose connection with harness connector.

OK or NG

OK >> **INSPECTION END**
NG >> Repair or replace damaged parts.

DTC P1705 THROTTLE POSITION SENSOR [ACCELERATOR PEDAL POSITION (APP) SENSOR]

DTC P1705 THROTTLE POSITION SENSOR [ACCELERATOR PEDAL POSITION (APP) SENSOR]

PFP:22560

Description

ECS006D1

The throttle position sensor [accelerator pedal position (APP) sensor] is part of the system that controls throttle position. This system also uses an electric throttle control actuator, which consists of a throttle control motor and throttle position sensors. Accelerator pedal position signal is sent to the ECM.

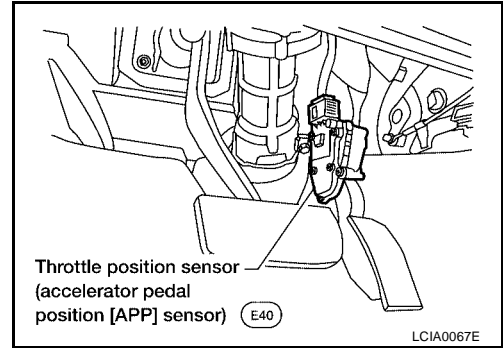

CONSULT-II REFERENCE VALUE IN DATA MONITOR MODE

Remarks: Specification data are reference values.

Monitor item	Condition	Specification
Throttle position sensor [accelerator pedal position (APP) sensor]	Fully-closed throttle	Approximately 0.5V
	Fully-open throttle	Approximately 4V

DTC P1705 THROTTLE POSITION SENSOR [ACCELERATOR PEDAL POSITION (APP) SENSOR]

On Board Diagnosis Logic

ECS006D2

Diagnostic trouble code TP SEN/CIRC A/T or P1705 with CONSULT-II, or 3rd judgement flicker without CONSULT-II is detected when TCM receives an excessively low or high voltage from the ECM.

Possible Cause

ECS006D3

Harness or connectors
(The sensor circuit is open or shorted.)

Diagnostic Trouble Code (DTC) Confirmation Procedure

ECS006D4

CAUTION:

Always drive vehicle at a safe speed.

NOTE:

If "DTC Confirmation Procedure" has been previously conducted, always turn ignition switch OFF and wait at least 10 seconds before conducting the next test.

After the repair, perform the following procedure to confirm the malfunction is eliminated.

WITH CONSULT-II

1. Turn ignition switch ON and select "DATA MONITOR" mode for "A/T" with CONSULT-II.
2. Touch "SELECTION FROM MENU".
3. Touch "THRTL POS SEN".
Touch "START"

Accelerator pedal condition	THRTL POS SEN
Fully released	Less than 4.7V
Partially depressed	0.1 - 4.6V
Fully depressed	1.9 - 4.6V

If the check result is NG, go to [AT-179, "Diagnostic Procedure"](#).
If the check result is OK, go to following step.

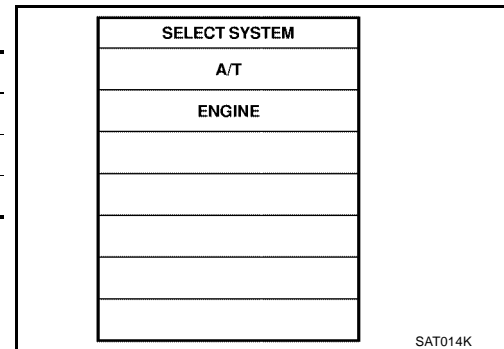

4. Turn ignition switch ON and select "DATA MONITOR" mode for "ENGINE" with CONSULT-II.
5. Touch "SELECTION FROM MENU"
6. Touch "VHCL SPEED SE" and "THRTL SEN 1".
Touch "START".
7. Start engine and maintain the following conditions for at least 3 consecutive seconds. Then release accelerator pedal completely.

VHCL SPEED SE: 10 km/h (6 MPH) or more

THRTL POS 1: Approximately 3V or less

Selector lever: D position

If the check result is NG, go to [AT-179, "Diagnostic Procedure"](#).

If the check result is OK, go to following step.

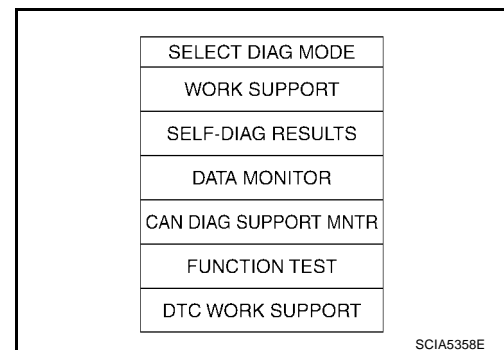

8. Maintain the following conditions for at least 3 consecutive seconds. Then release accelerator pedal completely.

VHCL SPEED SE: 10 km/h (6 MPH) or more

Accelerator pedal: Wide open throttle

DTC P1705 THROTTLE POSITION SENSOR [ACCELERATOR PEDAL POSITION (APP) SENSOR]

Selector lever: D position

SELECT SYSTEM
A/T
ENGINE

SAT014K

SELECT DIAG MODE
WORK SUPPORT
SELF-DIAG RESULTS
DATA MONITOR
DATA MONITOR (SPEC)
CAN DIAG SUPPORT MNTR
ACTIVE TEST

PBIB2308E

A
B
AT
D
E
F
G
H
I
J
K
L
M

WITH GST

Follow the procedure "With CONSULT-II".

DTC P1705 THROTTLE POSITION SENSOR [ACCELERATOR PEDAL POSITION (APP) SENSOR]

Wiring Diagram — AT — TPS

ECS006D5

AT-TPS-01

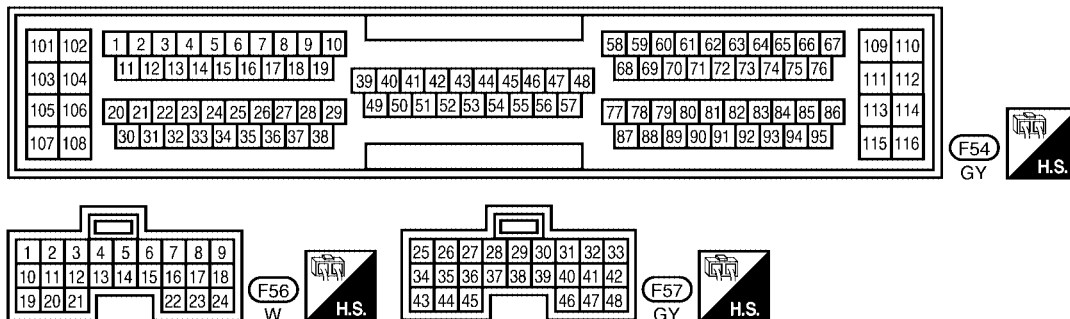
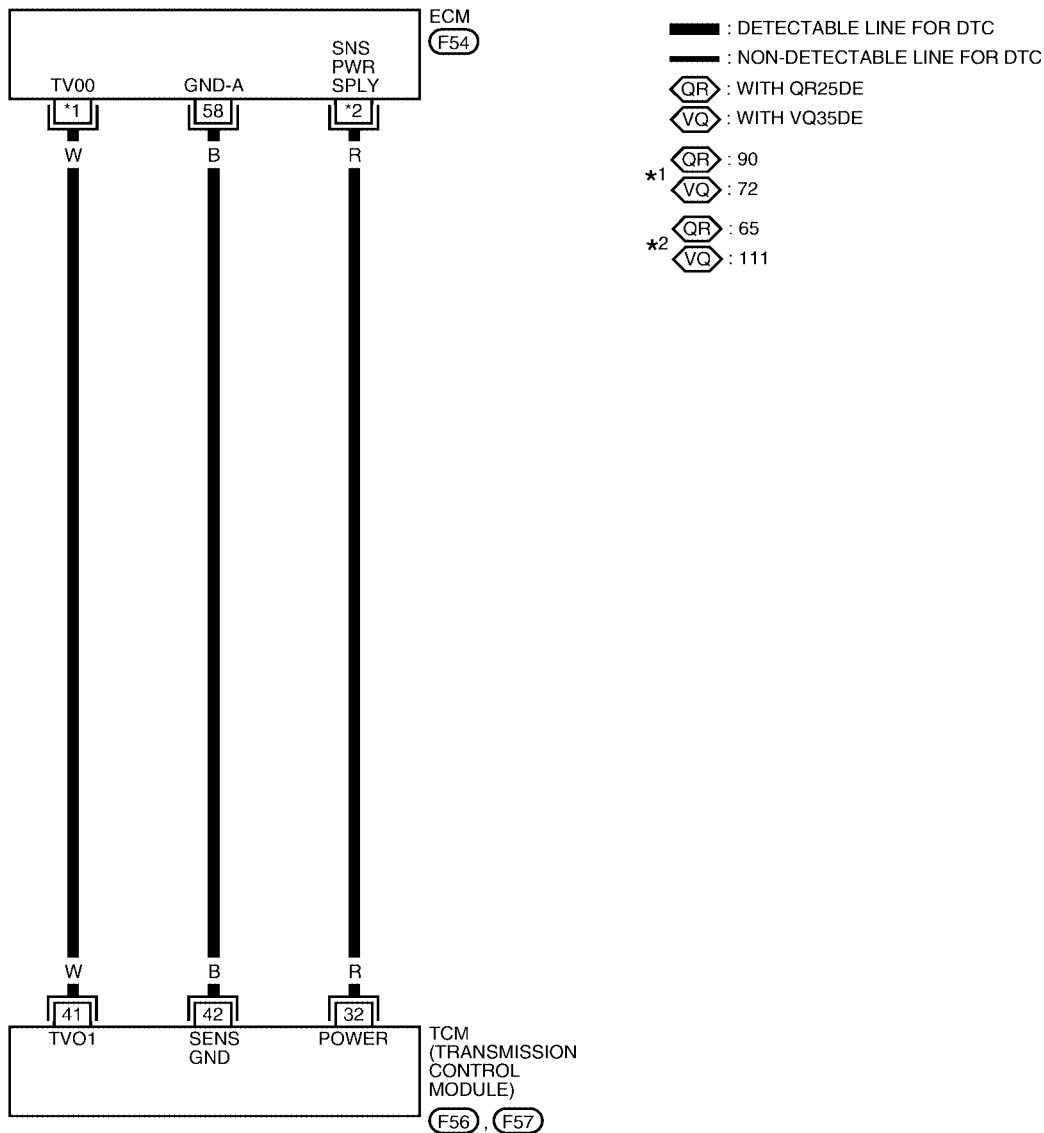

LCWA0019E

DTC P1705 THROTTLE POSITION SENSOR [ACCELERATOR PEDAL POSITION (APP) SENSOR]

TCM TERMINALS AND REFERENCE VALUE MEASURED BETWEEN EACH TERMINAL AND 25 OR 48 (TCM GROUND)				
TERMINAL	WIRE COLOR	ITEM	CONDITION	DATA (APPROX.)
32	R	SENSOR POWER	IGNITION SWITCH ON	4.5 -5.5V
			IGNITION SWITCH OFF	0V
41	W	THROTTLE POSITION SENSOR [ACCELERATOR PEDAL POSITION (APP) SENSOR]	IGNITION ON AND ACCELERATOR PEDAL IS DEPRESSED SLOWLY AFTER WARMING UP ENGINE	FULLY CLOSED THROTTLE: 0.5V FULLY OPEN THROTTLE: 4V
42	B	SENSOR GROUND	—	—

Diagnostic Procedure

ECS006D6

1. CHECK DTC WITH ECM

- Check P code with CONSULT-II "ENGINE".
Turn ignition switch ON and select "SELF DIAGNOSTIC RESULTS" mode for "ENGINE" with CONSULT-II.

Refer to [EC-68. "Malfunction Indicator Lamp \(MIL\)"](#) (with QR25DE), or [EC-693. "Malfunction Indicator Lamp \(MIL\)"](#) (with VQ35DE).

OK or NG

OK (with CONSULT-II)>> GO TO 2.

NG >> Check accelerator pedal position (APP) sensor circuit for engine control. Refer to [EC-178. "DTC P0122, P0123 TP SENSOR"](#) and [EC-534. "DTC P2122, P2123 APP SENSOR"](#) (with QR25DE), or [EC-822. "DTC P0122, P0123 TP SENSOR"](#) and [EC-1209. "DTC P2122, P2123 APP SENSOR"](#) (with VQ35DE). If CAN communication line is detected, GO TO [AT-186. "DTC U1000 CAN COMMUNICATION LINE"](#).

2. CHECK INPUT SIGNAL (WITH CONSULT-II)

 **With CONSULT-II**

- Turn ignition switch to ON position.
(Do not start engine.)
- Select "TCM INPUT SIGNALS" in "DATA MONITOR" mode for "A/T" with CONSULT-II.
- Read out the value of "THRTL POS SEN".

Voltage:

Fully-closed throttle :Approximately 0.5V

Fully-open throttle :Approximately 4V

OK or NG

OK >> GO TO 4.

NG >> Check harness for short or open between ECM and TCM regarding throttle position sensor circuit. (Main harness)

DATA MONITOR	
MONITORING	
VHCL/S SE-A/T	XXX km/h
VHCL/S SE-MTR	XXX km/h
THRTL POS SEN	XXX V
FLUID TEMP SE	XXX V
BATTERY VOLT	XXX V

LCIA0090E

DTC P1705 THROTTLE POSITION SENSOR [ACCELERATOR PEDAL POSITION (APP) SENSOR]

3. CHECK INPUT SIGNAL (WITHOUT CONSULT-II)

⊗ Without CONSULT-II

1. Turn ignition switch to ON position. (Do not start engine.)
2. Check voltage between TCM terminals 41 (W) and 42 (B) while accelerator pedal is depressed slowly.

Voltage:

Fully-closed throttle valve :Approximately 0.5V

Fully-open throttle valve :Approximately 4V

(Voltage rises gradually in response to throttle position.)

OK or NG

OK >> GO TO 4.

NG >> Check harness for short or open between ECM and TCM regarding throttle position sensor circuit. (Main harness)

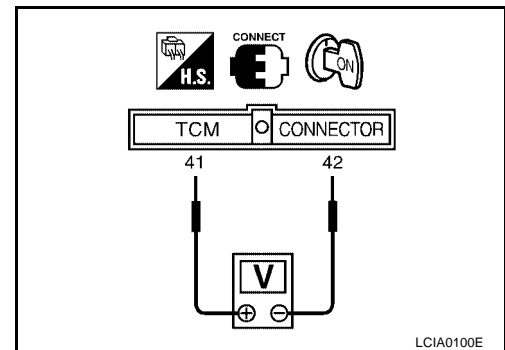

4. CHECK TCM INSPECTION

1. Perform TCM input/output signal inspection.
2. If NG, recheck TCM pin terminals for damage or loose connection with harness connector.

OK or NG

OK >> **INSPECTION END**

NG >> Repair or replace damaged parts.

DTC P1760 OVERRUN CLUTCH SOLENOID VALVE

DTC P1760 OVERRUN CLUTCH SOLENOID VALVE

PFP:31940

Description

ECS006D7

The overrun clutch solenoid valve is activated by the TCM in response to signals sent from the park/neutral position (PNP) switch, overdrive control switch, vehicle speed and ECM (throttle opening). The overrun clutch operation will then be controlled.

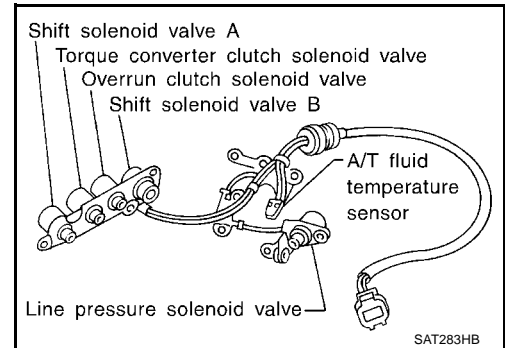

On Board Diagnosis Logic

ECS006D8

Diagnostic trouble code O/R CLTCH SOL/CIRC with CONSULT-II or P1760 without CONSULT-II is detected when TCM detects an improper voltage drop when it tries to operate the solenoid valve.

Possible Cause

ECS006D9

Check the following items.

- Harness or connectors
(The solenoid circuit is open or shorted.)
- Overrun clutch solenoid valve

Diagnostic Trouble Code (DTC) Confirmation Procedure

ECS006DA

CAUTION:

Always drive vehicle at a safe speed.

NOTE:

If "DIAGNOSTIC TROUBLE CODE CONFIRMATION PROCEDURE" has been previously conducted, always turn ignition switch OFF and wait at least 10 seconds before conducting the next test.

TESTING CONDITION:

Always drive vehicle on a level road to improve accuracy of test.

After the repair, perform the following procedure to confirm the malfunction is eliminated.

WITH CONSULT-II

1. Turn ignition switch ON and select "DATA MONITOR" mode for "A/T" with CONSULT-II.
2. Touch "MAIN SIGNALS".
Touch "START".
3. Start engine.
4. Accelerate vehicle to a speed of more than 10 km/h (6 MPH) with selector lever in D position.

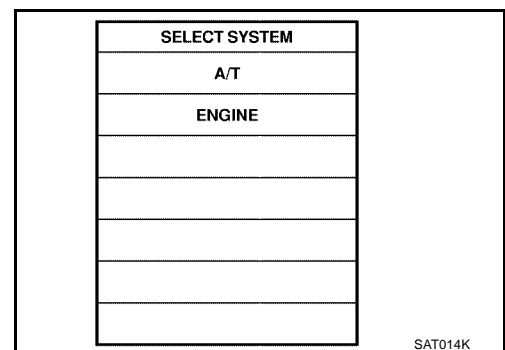

DTC P1760 OVERRUN CLUTCH SOLENOID VALVE

5. Release accelerator pedal completely with selector lever in 3 position.

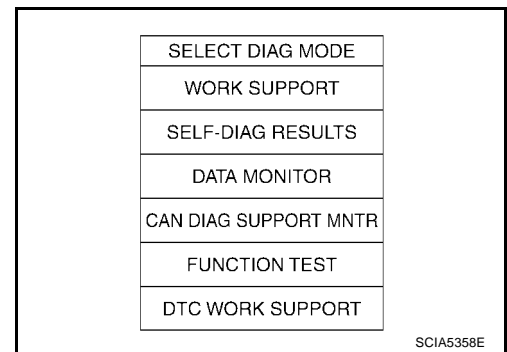

6. Verify operation of "OVERRUN/C S/V".

WITH GST

Follow the procedure "With CONSULT-II".

DTC P1760 OVERRUN CLUTCH SOLENOID VALVE

Wiring Diagram — AT — OVRCSV

ECS006DB

AT-OVRCSV-01

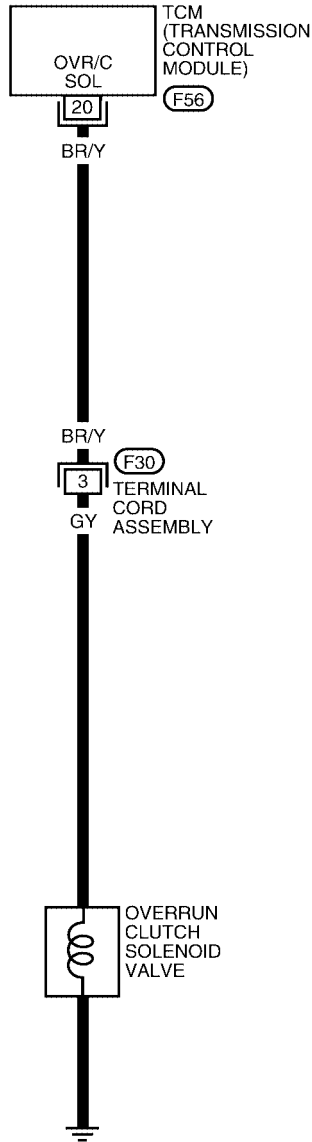

— : DETECTABLE LINE FOR DTC
 — : NON-DETECTABLE LINE FOR DTC

A
 B
AT
 D
 E
 F
 G
 H
 I
 J
 K
 L
 M

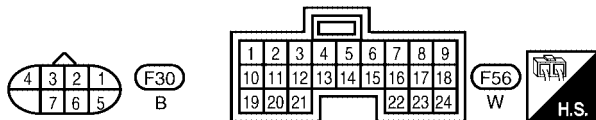

WCWA0053E

DTC P1760 OVERRUN CLUTCH SOLENOID VALVE

TCM TERMINALS AND REFERENCE VALUE MEASURED BETWEEN EACH TERMINAL AND 25 OR 48 (TCM GROUND)

TERMINAL	WIRE COLOR	ITEM	CONDITION	DATA (APPROX.)
20	BR/Y	OVERRUN CLUTCH SOLENOID VALVE	WHEN OVERRUN CLUTCH SOLENOID VALVE OPERATES	BATTERY VOLTAGE
			WHEN OVERRUN CLUTCH SOLENOID VALVE DOES NOT OPERATE	0V

Diagnostic Procedure

ECS006DC

1. CHECK VALVE RESISTANCE

1. Turn ignition switch to OFF position.
2. Disconnect terminal cord assembly connector in engine compartment.
3. Check resistance between terminal cord assembly F30 terminal 3 (component side) and ground.

Resistance : 20 - 30Ω

OK or NG

- OK >> GO TO 3.
NG >> GO TO 2.

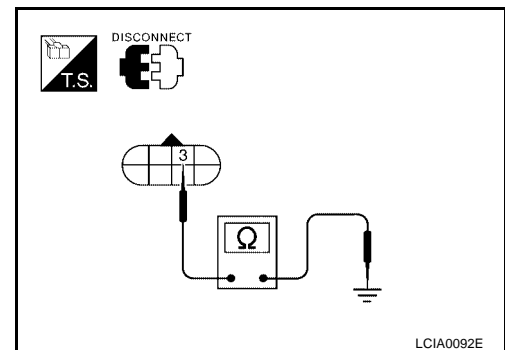

2. CHECK VALVE OPERATION

1. Remove control valve assembly. Refer to [AT-264, "Control Valve Assembly and Accumulators"](#).
2. Check the following items:
 - Overrun clutch solenoid valve
 - Operation check
 - Check solenoid valve by listening for its operating sound while applying battery voltage to the terminal and ground.
 - Harness of terminal cord assembly for short or open

OK or NG

- OK >> GO TO 3.
NG >> Repair or replace damaged parts.

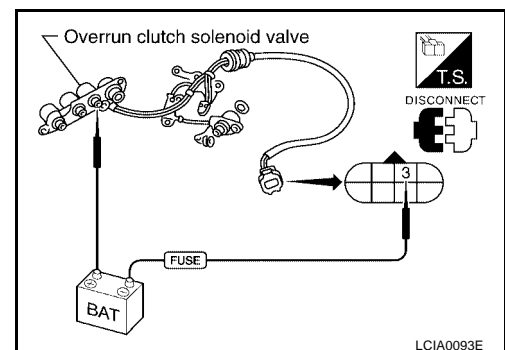

3. CHECK POWER SOURCE CIRCUIT

1. Turn ignition switch to OFF position.
2. Disconnect TCM harness connector.
3. Check continuity between terminal cord assembly harness connector terminal 3 and TCM harness connector terminal 20. Refer to [AT-183, "Wiring Diagram — AT — OVRCSV"](#).

Continuity should exist.

4. Reinstall any part removed.

OK or NG

- OK >> GO TO 4.
NG >> Repair open circuit or short to ground or short to power in harness or connectors.

DTC P1760 OVERRUN CLUTCH SOLENOID VALVE

4. CHECK DTC

Perform [AT-181, "Diagnostic Trouble Code \(DTC\) Confirmation Procedure"](#) .

OK or NG

OK >> **INSPECTION END**

NG >> GO TO 5.

5. CHECK TCM INSPECTION

1. Perform TCM input/output signal inspection.
2. If NG, recheck TCM pin terminals for damage or loose connection with harness connector.

OK or NG

OK >> **INSPECTION END**

NG >> Repair or replace damaged parts.

A

B

AT

D

E

F

G

H

I

J

K

L

M

DTC U1000 CAN COMMUNICATION LINE

DTC U1000 CAN COMMUNICATION LINE

PFP:23710

Description

ECS006DD

CAN (Controller Area Network) is a serial communication line for real time application. It is an on-vehicle multiplex communication line with high data communication speed and excellent error detection ability. Many electronic control units are equipped onto a vehicle, and each control unit shares information and links with other control units during operation (not independent). In CAN communication, control units are connected with 2 communication lines (CAN H line, CAN L line) allowing a high rate of information transmission with less wiring. Each control unit transmits/receives data but selectively reads required data only.

On Board Diagnosis Logic

ECS006DE

- This is an OBD-II self-diagnostic item.
- Diagnostic trouble code A/T COMM LINE or U1000 with CONSULT-II and 12th judgement flicker without CONSULT-II is detected when TCM cannot communicate to other control unit.

Possible Cause

ECS006DF

Harness or connectors
(CAN communication line is open or shorted.)

DTC Confirmation Procedure

ECS006DG

NOTE:

If "DTC Confirmation Procedure" has been previously conducted, always turn ignition switch "OFF" and wait at least 10 seconds before conducting the next test.

After the repair, perform the following procedure to confirm the malfunction is eliminated.

④ WITH CONSULT-II

1. Turn ignition switch to "ON" position. (Do not start engine.)
2. Select "DATA MONITOR" mode for "ENGINE" with CONSULT-II.
3. Start engine and wait for at least 6 seconds.
4. If DTC is detected, go to [AT-188, "Diagnostic Procedure"](#).

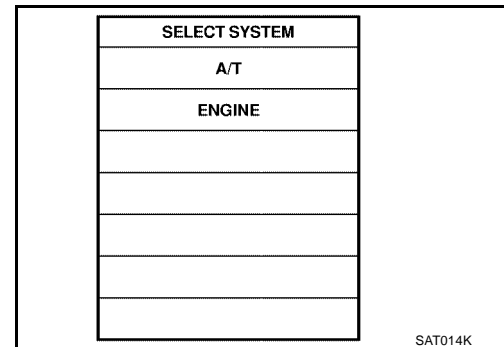

④ WITH GST

Follow the procedure "WITH CONSULT-II".

⊗ WITHOUT CONSULT-II

1. Turn ignition switch "ON".
2. Wait at least 6 seconds or start engine and wait at least 6 seconds.
3. Perform self-diagnosis. Refer to [AT-51, "TCM SELF-DIAGNOSTIC PROCEDURE \(NO TOOLS\)"](#).

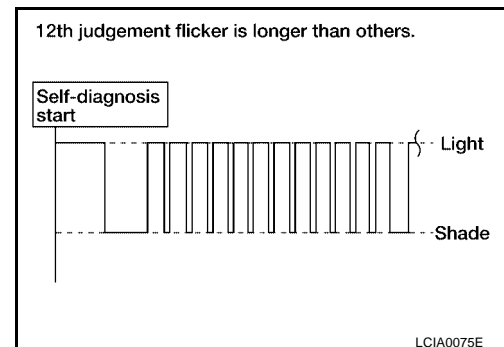

DTC U1000 CAN COMMUNICATION LINE

Wiring Diagram — AT — CAN

ECS006DH

AT-CAN-01

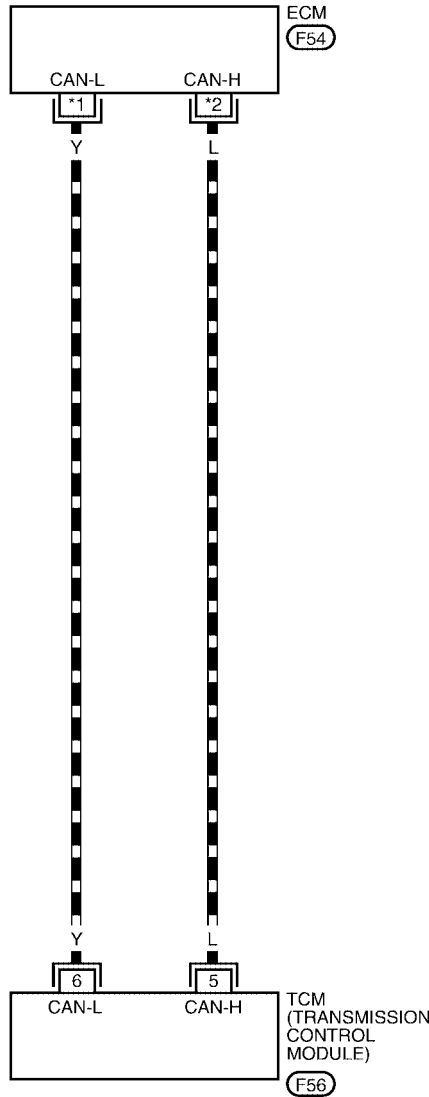

- : DETECTABLE LINE FOR DTC
- : NON-DETECTABLE LINE FOR DTC
- : DATA LINE
- : WITH QR25DE
- : WITH VQ35DE
- *1 : 34
- *1 : 113
- *2 : 33
- *2 : 109

A
B
AT
D
E
F
G
H
I
J
K
L
M

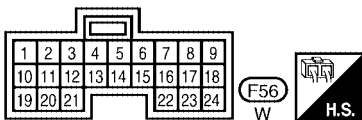

REFER TO THE FOLLOWING.
 - ELECTRICAL UNITS

LCWA0024E

DTC U1000 CAN COMMUNICATION LINE

ECS006DI

Diagnostic Procedure

1. CHECK CAN COMMUNICATION CIRCUIT

 With CONSULT-II

1. Turn ignition switch "ON" and start engine.
2. Select "SELF-DIAG RESULTS" mode for "A/T" with CONSULT-II.

Is any malfunction of the "CAN COMM CIRCUIT" indicated?

Yes >> Print out CONSULT-II screen, GO TO LAN section.
Refer to [LAN-28. "CAN SYSTEM \(FOR A/T MODELS\)"](#)

No >> Inspection End.

SELF-DIAG RESULTS			
DTC RESULTS			
CAN COMM CIRCUIT [U1000]			
ERASE		PRINT	
MODE	BACK	LIGHT	COPY

PCIA0061E

DTC BATT/FLUID TEMP SEN (A/T FLUID TEMP SENSOR CIRCUIT AND TCM POWER SOURCE)

DTC BATT/FLUID TEMP SEN (A/T FLUID TEMP SENSOR CIRCUIT AND TCM POWER SOURCE)

PFP:31940

Description

ECS006DJ

The A/T fluid temperature sensor detects the A/T fluid temperature and sends a signal to the TCM.

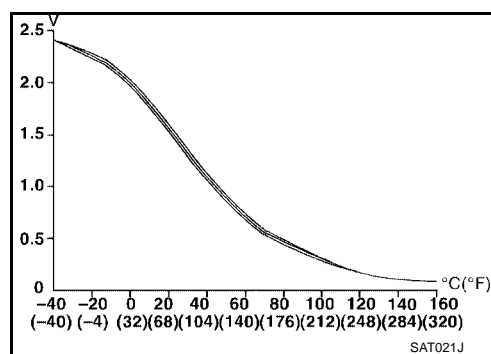
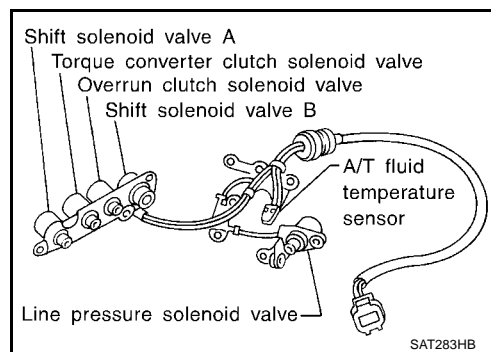

CONSULT-II REFERENCE VALUE IN DATA MONITOR MODE

Remarks: Specification data are reference values.

Monitor item	Condition	Specification (Approximately)	
A/T fluid temperature sensor	Cold [20°C (68°F)]	1.5V	2.5 kΩ
	Hot [80°C (176°F)]	0.5V	0.3 kΩ

On Board Diagnosis Logic

ECS006DK

Diagnostic trouble code BATT/FLUID TEMP SEN with CONSULT-II or 8th judgement flicker without CONSULT-II is detected when TCM receives an excessively low or high voltage from the sensor.

Possible Cause

ECS006DL

Check the following items.

- Harness or connectors
(The sensor circuit is open or shorted.)
- A/T fluid temperature sensor

Diagnostic Trouble Code (DTC) Confirmation Procedure

ECS006DM

After the repair, perform the following procedure to confirm the malfunction is eliminated.

WITH CONSULT-II

1. Start engine.

DTC BATT/FLUID TEMP SEN (A/T FLUID TEMP SENSOR CIRCUIT AND TCM POWER SOURCE)

2. Select "DATA MONITOR" mode for "A/T" with CONSULT-II.

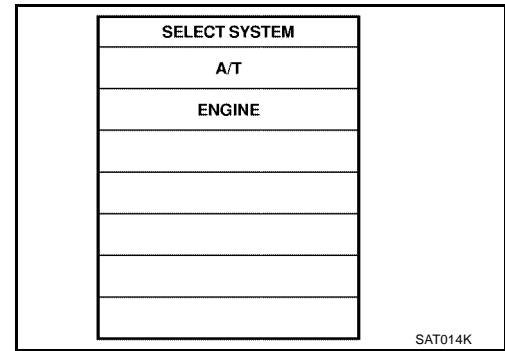

3. Drive vehicle under the following conditions:
Selector lever in "D", vehicle speed higher than 20 km/h (12 MPH).

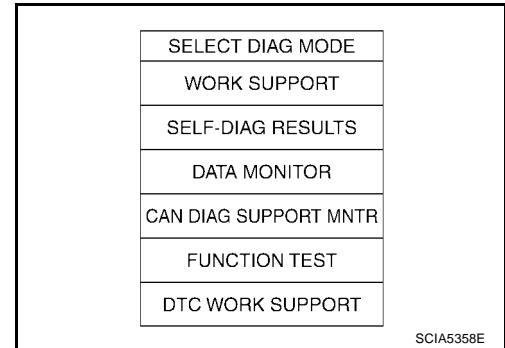

WITHOUT CONSULT-II

1. Start engine.
2. Drive vehicle under the following conditions:
Selector lever in "D", vehicle speed higher than 20 km/h (12 MPH).
3. Perform self-diagnosis.
Refer to [AT-51, "TCM SELF-DIAGNOSTIC PROCEDURE \(NO TOOLS\)"](#).

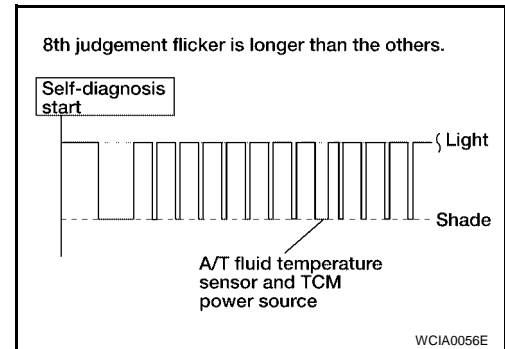

DTC BATT/FLUID TEMP SEN (A/T FLUID TEMP SENSOR CIRCUIT AND TCM POWER SOURCE)

Wiring Diagram — AT — BA/FTS

ECS006DN

AT-BA/FTS-01

: DETECTABLE LINE FOR DTC
 : NON-DETECTABLE LINE FOR DTC

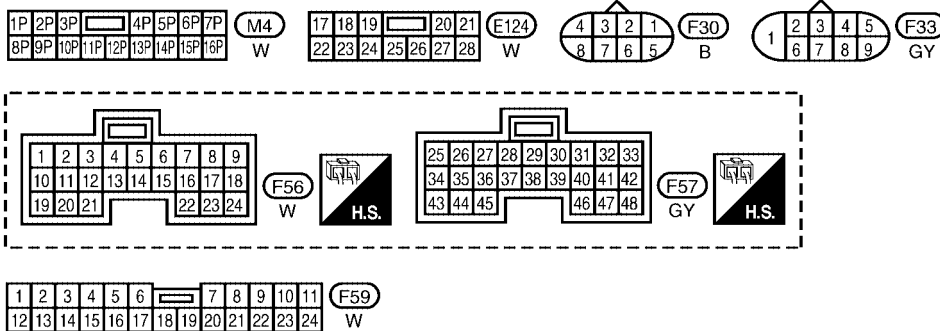
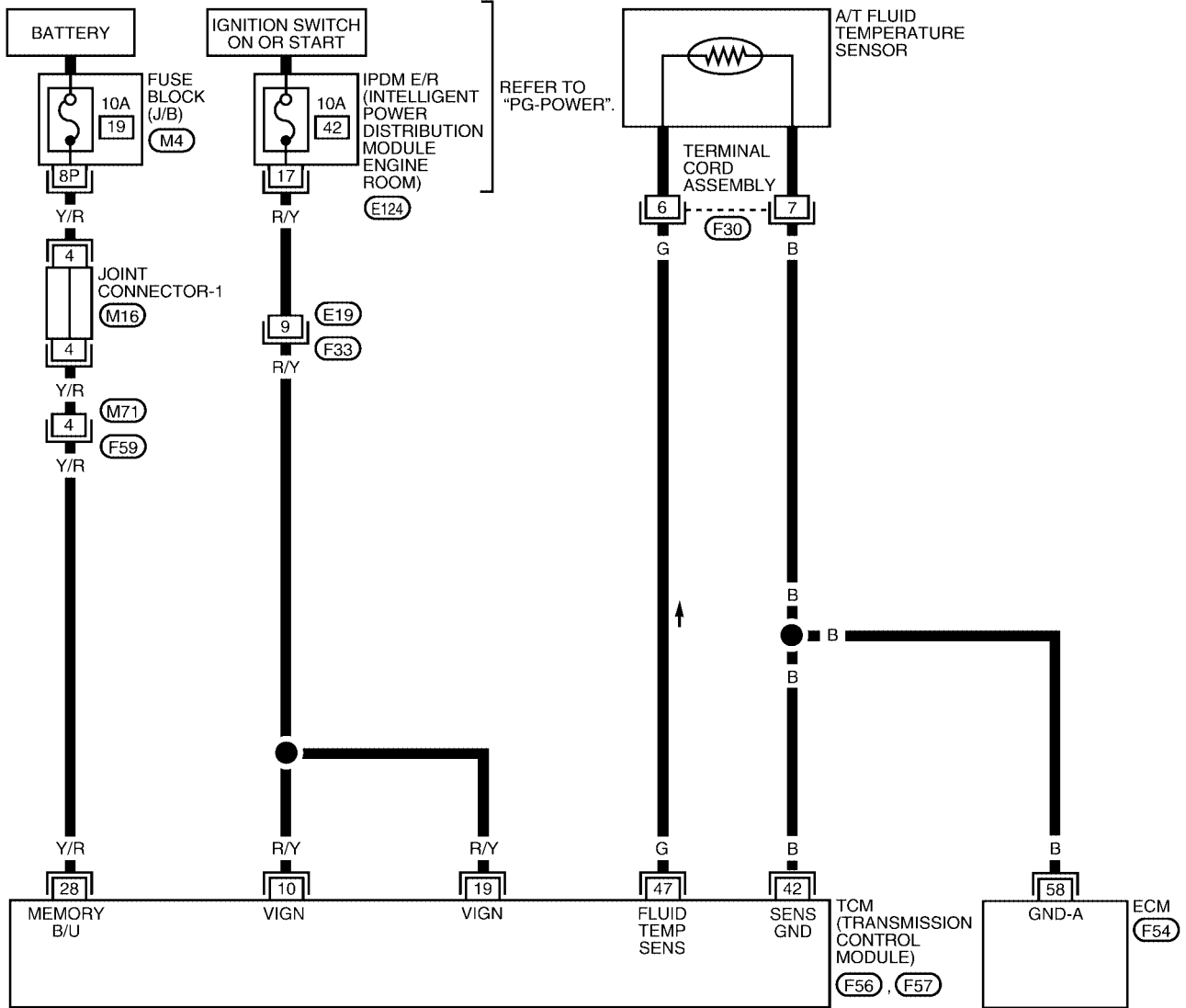

REFER TO THE FOLLOWING.
 (F54) - ELECTRICAL UNITS
 (M16) - JOINT CONNECTOR (JC)

WCWA0054E

DTC BATT/FLUID TEMP SEN (A/T FLUID TEMP SENSOR CIRCUIT AND TCM POWER SOURCE)

TERMINALS AND REFERENCE VALUE MEASURED BETWEEN EACH TERMINAL				
TERMINAL	WIRE COLOR	ITEM	CONDITION	DATA (APPROX.)
10	R/Y	POWER SOURCE	IGNITION ON	BATTERY VOLTAGE
			IGNITION OFF	0V
19	R/Y	POWER SOURCE	IGNITION ON	BATTERY VOLTAGE
			IGNITION OFF	0V
28	Y/R	POWER SOURCE (MEMORY BACKUP)	IGNITION ON	BATTERY VOLTAGE
			IGNITION OFF	BATTERY VOLTAGE
42	B	SENSOR GROUND	—	—
47	G	A/T FLUID TEMPERATURE SENSOR	IGNITION ON WITH ATF TEM- PERATURE AT 20°C (68°F)	1.5V
			IGNITION ON WITH ATF TEM- PERATURE AT 80°C (176°F)	0.5V

Diagnostic Procedure

ECS006DO

1. CHECK INPUT SIGNAL OF A/T FLUID TEMPERATURE SENSOR (WITH CONSULT-II)

With CONSULT-II

1. Start engine.
2. Select "TCM INPUT SIGNALS" in "DATA MONITOR" mode for "A/T" with CONSULT-II.
3. Read out the value of "FLUID TEMP SE".

Voltage :Cold [20°C (68°F)] → Hot [80°C (176°F)]
:Approximately 1.5V → 0.5V

OK or NG

- OK >> GO TO 9.
NG >> GO TO 2.

DATA MONITOR	
MONITORING	VALUE
VHCL/S SE-A/T	XXX km/h
VHCL/S SE-MTR	XXX km/h
THRTL POS SEN	XXX V
FLUID TEMP SE	XXX V
BATTERY VOLT	XXX V

LCIA0090E

2. DETECT MALFUNCTIONING ITEM

Check the following items:

- Harness for short or open between TCM, ECM and terminal cord assembly (Main harness)
- Ground circuit for ECM
Refer to [EC-131, "POWER SUPPLY CIRCUIT FOR ECM"](#) (with QR25DE), or [EC-763, "POWER SUPPLY CIRCUIT FOR ECM"](#) (with VQ35DE).

OK or NG

- OK >> GO TO 9.
NG >> Repair or replace damaged parts.

DTC BATT/FLUID TEMP SEN (A/T FLUID TEMP SENSOR CIRCUIT AND TCM POWER SOURCE)

3. CHECK TCM POWER SOURCE STEP 1

1. Turn ignition switch to ON position.
(Do not start engine.)
2. Check voltage between TCM harness connector terminals 10 (R/Y), 19 (R/Y), 28 (Y/R) and ground.

Voltage : Battery voltage

OK or NG

- OK >> GO TO 4.
NG >> GO TO 5.

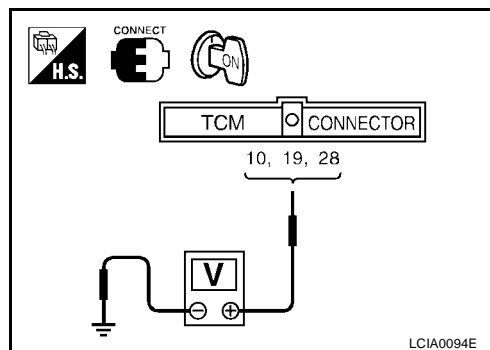

4. CHECK TCM POWER SOURCE STEP 2

1. Turn ignition switch to OFF position.
2. Check voltage between TCM harness connector terminal 28 (Y/R) and ground.

Voltage : Battery voltage

OK or NG

- OK >> GO TO 6.
NG >> GO TO 5.

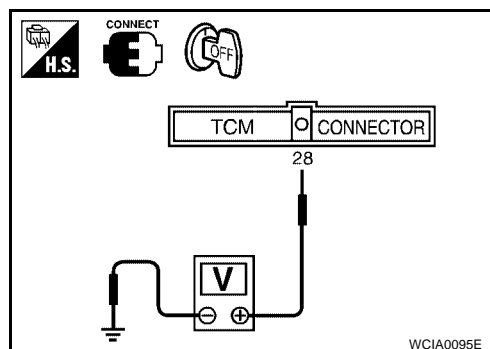

5. DETECT MALFUNCTIONING ITEM

Check the following items:

- Harness for short or open between ignition switch and TCM (Main harness)
- Ignition switch and fuse
Refer to [PG-3, "POWER SUPPLY ROUTING CIRCUIT"](#).

OK or NG

- OK >> GO TO 6.
NG >> Repair or replace damaged parts.

6. CHECK A/T FLUID TEMPERATURE SENSOR WITH TERMINAL CORD ASSEMBLY

1. Turn ignition switch to OFF position.
2. Disconnect terminal cord assembly connector in engine compartment.
3. Check resistance between terminal cord assembly F30 terminals 6 and 7 (component side) when A/T is cold.

Temperature	Resistance (Approx.)
Cold 20°C (68°F)	2.5kΩ

4. Reinstall any part removed.

OK or NG

- OK (without CONSULT-II) >> GO TO 8.
NG >> GO TO 7.

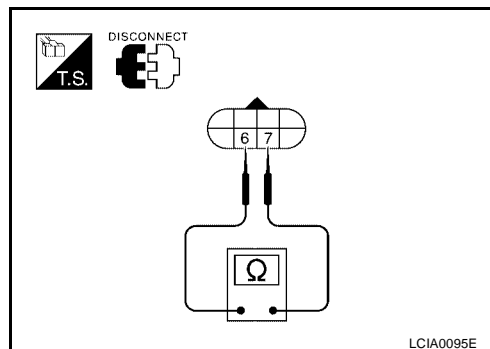

DTC BATT/FLUID TEMP SEN (A/T FLUID TEMP SENSOR CIRCUIT AND TCM POWER SOURCE)

7. DETECT MALFUNCTIONING ITEM

1. Remove oil pan.
2. Check the following items:
 - A/T fluid temperature sensor
 - Check resistance between two terminals while changing temperature as shown.

Temperature °C (°F)	Resistance (Approx.)
20 (68)	2.5kΩ
80 (176)	0.3kΩ

- Harness of terminal cord assembly for short or open

OK or NG

OK (without CONSULT-II) >> GO TO 8.

NG >> Repair or replace damaged parts.

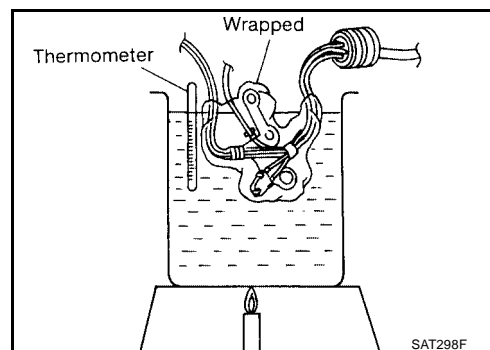

8. CHECK INPUT SIGNAL OF A/T FLUID TEMPERATURE SENSOR (WITHOUT CONSULT-II)

⊗ **Without CONSULT-II**

1. Start engine.
2. Check voltage between TCM harness connector terminal 47 and ground while warming up A/T.

Temperature	Voltage (Approx.)
Cold [20°C (68°F)] → Hot [80°C (176°F)]	1.5V → 0.5V

3. Turn ignition switch to OFF position.
4. Disconnect TCM harness connector.
5. Check resistance between terminal 42 and ground. Refer to [AT-191, "Wiring Diagram — AT — BA/FTS"](#).

Continuity should exist.

OK or NG

OK >> GO TO 10.

NG >> GO TO 9.

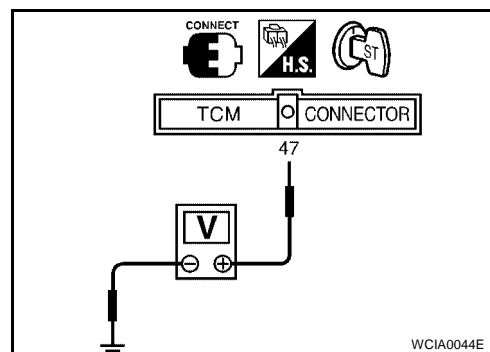

9. DETECT MALFUNCTIONING ITEM

Check the following items:

- Harness for short or open between TCM, ECM and terminal cord assembly (Main harness)
- Ground circuit for ECM
Refer to [EC-131, "POWER SUPPLY CIRCUIT FOR ECM"](#) (with QR25DE), or [EC-763, "POWER SUPPLY CIRCUIT FOR ECM"](#) (with VQ35DE).

OK or NG

OK >> GO TO 10.

NG >> Repair or replace damaged parts.

10. CHECK DTC

Perform [AT-189, "Diagnostic Trouble Code \(DTC\) Confirmation Procedure"](#).

OK or NG

OK >> **INSPECTION END**

NG >> GO TO 11.

DTC BATT/FLUID TEMP SEN (A/T FLUID TEMP SENSOR CIRCUIT AND TCM POWER SOURCE)

11. CHECK TCM INSPECTION

1. Perform TCM input/output signal inspection.
2. If NG, recheck TCM pin terminals for damage or loose connection with harness connector.

OK or NG

- OK >> **INSPECTION END**
NG >> Repair or replace damaged parts.

A

B

AT

D

E

F

G

H

I

J

K

L

M

DTC VEHICLE SPEED SENSOR MTR

DTC VEHICLE SPEED SENSOR MTR

PFP:24814

Description

ECS006DP

The vehicle speed sensor-MTR is built into the speedometer assembly. The sensor functions as an auxiliary device to the revolution sensor when it is malfunctioning. The TCM will then use a signal sent from the vehicle speed sensor-MTR.

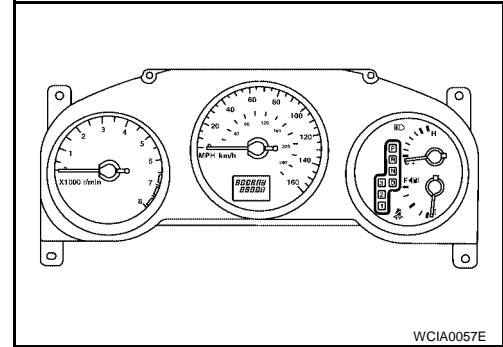

On Board Diagnosis Logic

ECS006DQ

Diagnostic trouble code VHCL SPEED SEN-MTR with CONSULT-II or 2nd judgement flicker without CONSULT-II is detected when TCM does not receive the proper voltage signal from the sensor.

Possible Cause

ECS006DR

Check the following items.

- Harness or connectors
(The sensor circuit is open or shorted.)
- Vehicle speed sensor

Diagnostic Trouble Code (DTC) Confirmation Procedure

ECS006DS

CAUTION:

- Always drive vehicle at a safe speed.
- If conducting this “DTC Confirmation Procedure” again, always turn ignition switch OFF and wait at least 10 seconds before continuing.

After the repair, perform the following procedure to confirm the malfunction is eliminated.

WITH CONSULT-II

1. Turn ignition switch ON and select “DATA MONITOR” mode for “A/T” with CONSULT-II.

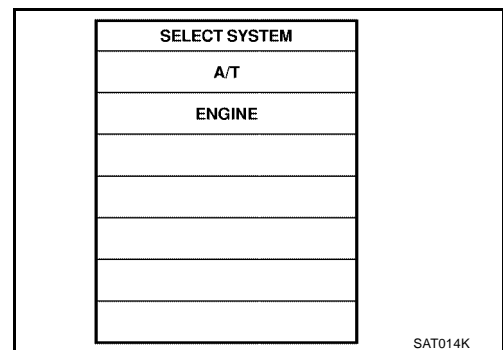

2. Start engine and accelerate vehicle from 0 to 25 km/h (0 to 16 MPH).

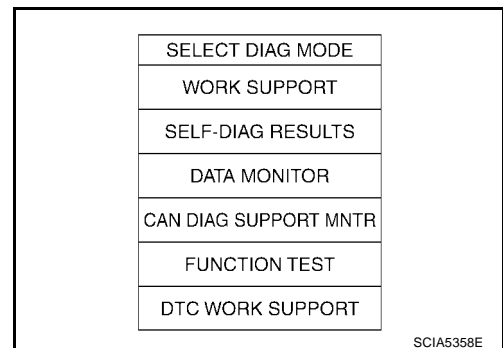

WITHOUT CONSULT-II

1. Start engine.

DTC VEHICLE SPEED SENSOR MTR

2. Drive vehicle under the following conditions:
Selector lever in D and vehicle speed higher than 25 km/h (16 MPH).
3. Perform self-diagnosis.
Refer to [AT-51, "TCM SELF-DIAGNOSTIC PROCEDURE \(NO TOOLS\)"](#) .

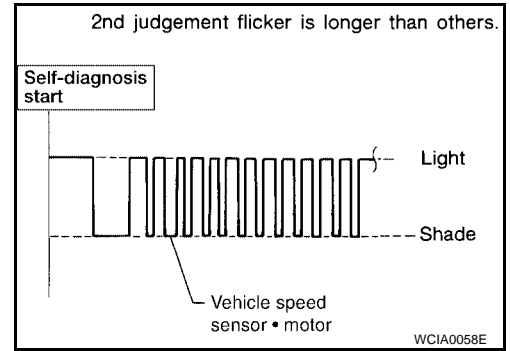

A

B

AT

D

E

F

G

H

I

J

K

L

M

DTC VEHICLE SPEED SENSOR MTR

ECS006DT

Wiring Diagram — AT — VSSMTR

AT-VSSMTR-01

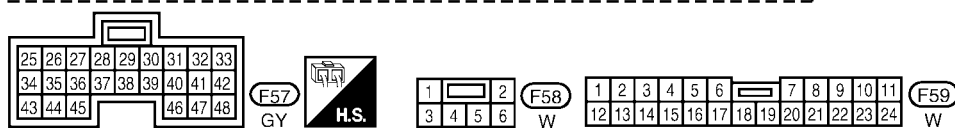
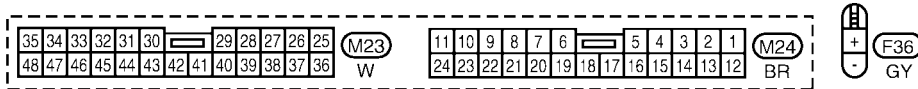
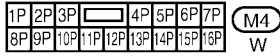
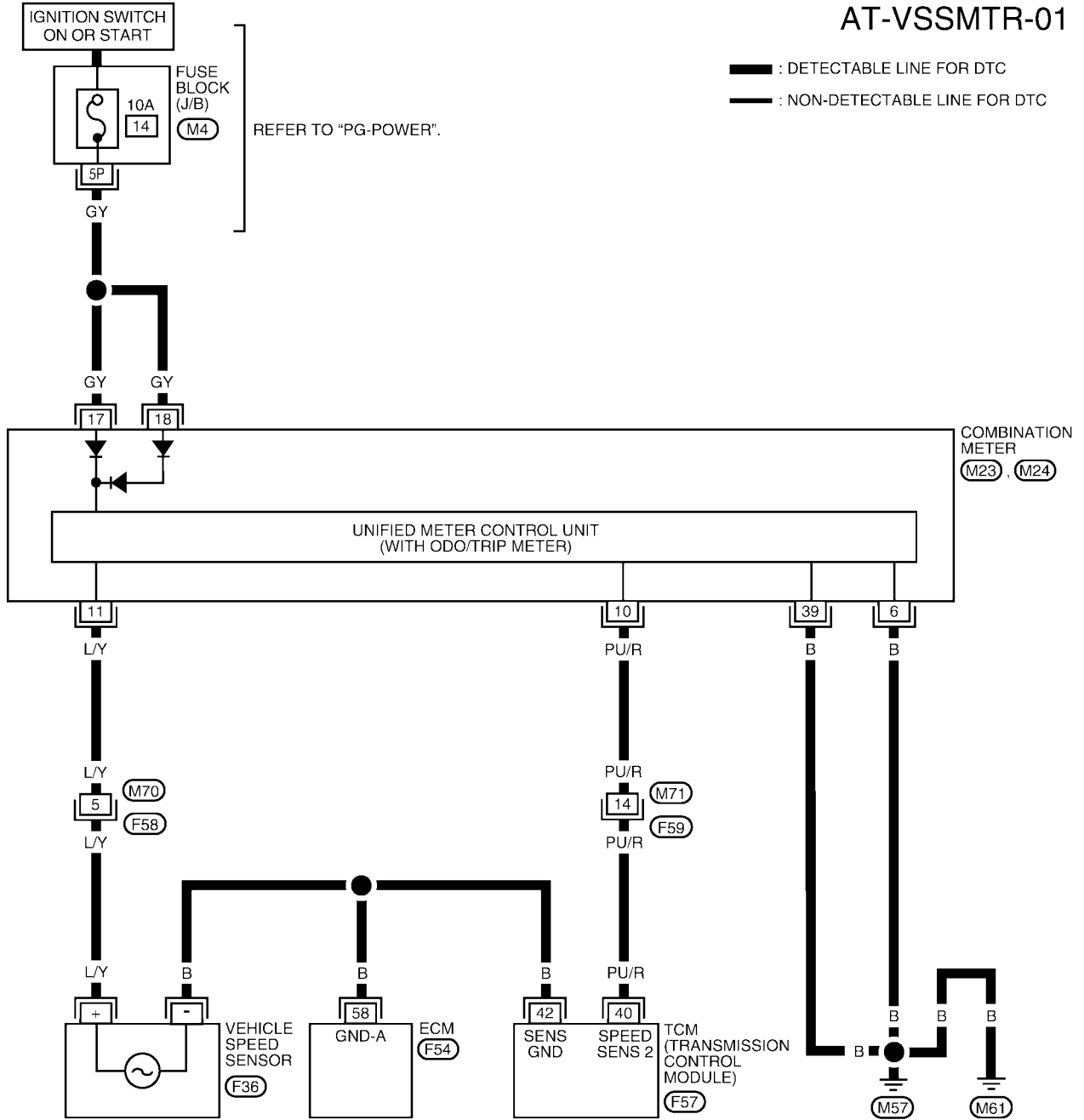

REFER TO THE FOLLOWING.
(F54) - ELECTRICAL UNITS

WCWA0055E

DTC VEHICLE SPEED SENSOR MTR

Diagnostic Procedure

ECS006DU

1. CHECK INPUT SIGNAL

With CONSULT-II

1. Start engine.
2. Select "TCM INPUT SIGNALS" in "DATA MONITOR" mode for "A/T" with CONSULT-II.
3. Read out the value of "VHCL/S SE·MTR" while driving. Check the value changes according to driving speed.

DATA MONITOR	
MONITORING	
VHCL/S SE-A/T	XXX km/h
VHCL/S SE-MTR	XXX km/h
THRTL POS SEN	XXX V
FLUID TEMP SE	XXX V
BATTERY VOLT	XXX V

LCIA0090E

Without CONSULT-II

1. Start engine.
2. Check voltage between TCM terminal 40 and ground while driving at 2 to 3 km/h (1 to 2 MPH) for 1 m (3 ft) or more.

Voltage : Voltage varies between less than 1V and more than 4.5V.

OK or NG

- OK >> GO TO 3.
NG >> GO TO 2.

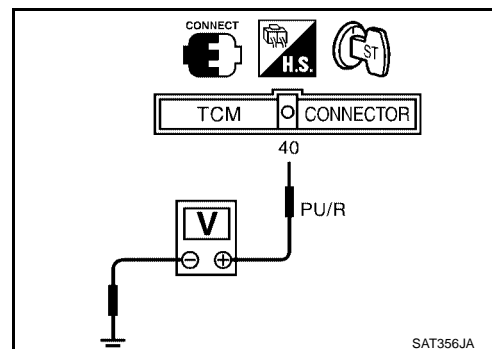

2. DETECT MALFUNCTIONING ITEM

Check the following items:

- Vehicle speed sensor and ground circuit for vehicle speed sensor
Refer to [DI-19, "Vehicle Speed System"](#) .
- Harness for short or open between TCM and vehicle speed sensor (Main harness)

OK or NG

- OK >> GO TO 3.
NG >> Repair or replace damaged parts.

3. CHECK DTC

Perform [AT-196, "Diagnostic Trouble Code \(DTC\) Confirmation Procedure"](#) .

OK or NG

- OK >> **INSPECTION END**
NG >> GO TO 4.

4. CHECK TCM INSPECTION

1. Perform TCM input/output signal inspection.
2. If NG, recheck TCM pin terminals for damage or loose connection with harness connector.

OK or NG

- OK >> **INSPECTION END**
NG >> Repair or replace damaged parts.

DTC TURBINE REVOLUTION SENSOR

PF3:31935

DTC TURBINE REVOLUTION SENSOR

ECS006DV

Description

The turbine revolution sensor detects forward clutch drum rpm (revolutions per minute). It is located on the input side of the automatic transaxle. The vehicle speed sensor A/T (Revolution sensor) is located on the output side of the automatic transaxle. With the two sensors, input and output rpms are accurately detected. The result is optimal shift timing during deceleration and improved shifting.

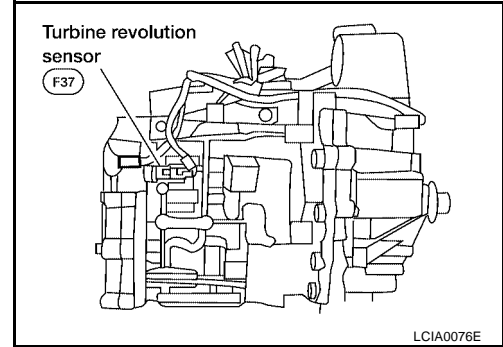

ON BOARD DIAGNOSIS LOGIC

Diagnostic trouble code	Malfunction is detected when ...	Check items (Possible cause)
ⓘ : TURBINE REV ⓘ : 10th judgement flicker	TCM does not receive the proper voltage signal from the sensor.	<ul style="list-style-type: none"> ● Harness or connectors (The sensor circuit is open or shorted.) ● Turbine revolution sensor

DIAGNOSTIC TROUBLE CODE (DTC) CONFIRMATION PROCEDURE

CAUTION:

- Always drive vehicle at a safe speed.
- If conducting this “DTC CONFIRMATION PROCEDURE” again, always turn ignition switch “OFF” and wait at least 5 seconds before continuing.

After the repair, perform the following procedure to confirm the malfunction is eliminated.

ⓘ With CONSULT-II

1. Start engine.

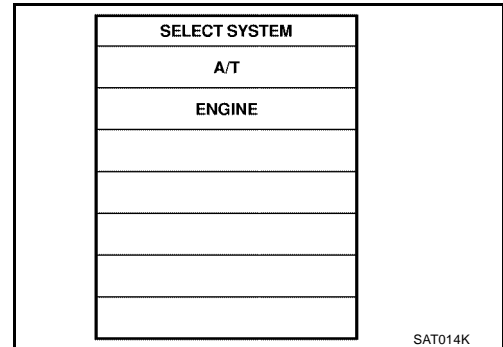

2. Select “DATA MONITOR” mode for “A/T” with CONSULT-II.
3. Drive vehicle under the following conditions: Selector lever in “D”, vehicle speed higher than 40 km/h (25 MPH), engine speed higher than 1,500 rpm, throttle opening greater than 1.0/8 of the full throttle position and driving for more than 5 seconds.

⊗ Without CONSULT-II

1. Start engine.
2. Drive vehicle under the following conditions: Selector lever in “D” and vehicle speed higher than 40 km/h (25 MPH), engine speed higher than 1,500 rpm, throttle opening greater than 1/8 of the full throttle position and driving for more than 5 seconds.

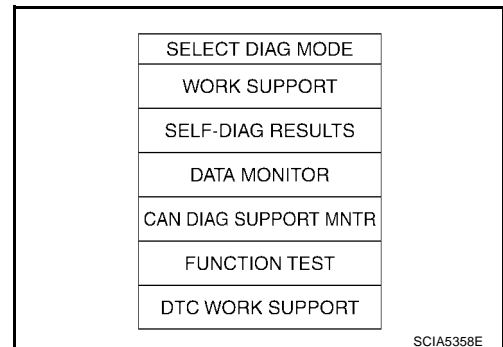

DTC TURBINE REVOLUTION SENSOR

3. Perform self-diagnosis.
Refer to [AT-51, "TCM SELF-DIAGNOSTIC PROCEDURE \(NO TOOLS\)"](#) .

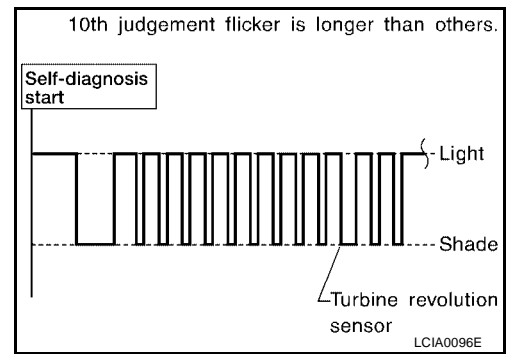

A
B
AT

D

E

F

G

H

I

J

K

L

M

DTC TURBINE REVOLUTION SENSOR

Wiring Diagram — AT — TRSA/T

ECS006DW

AT-TRSA/T-01

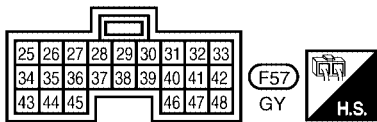
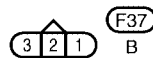
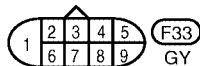
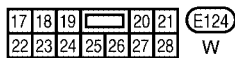
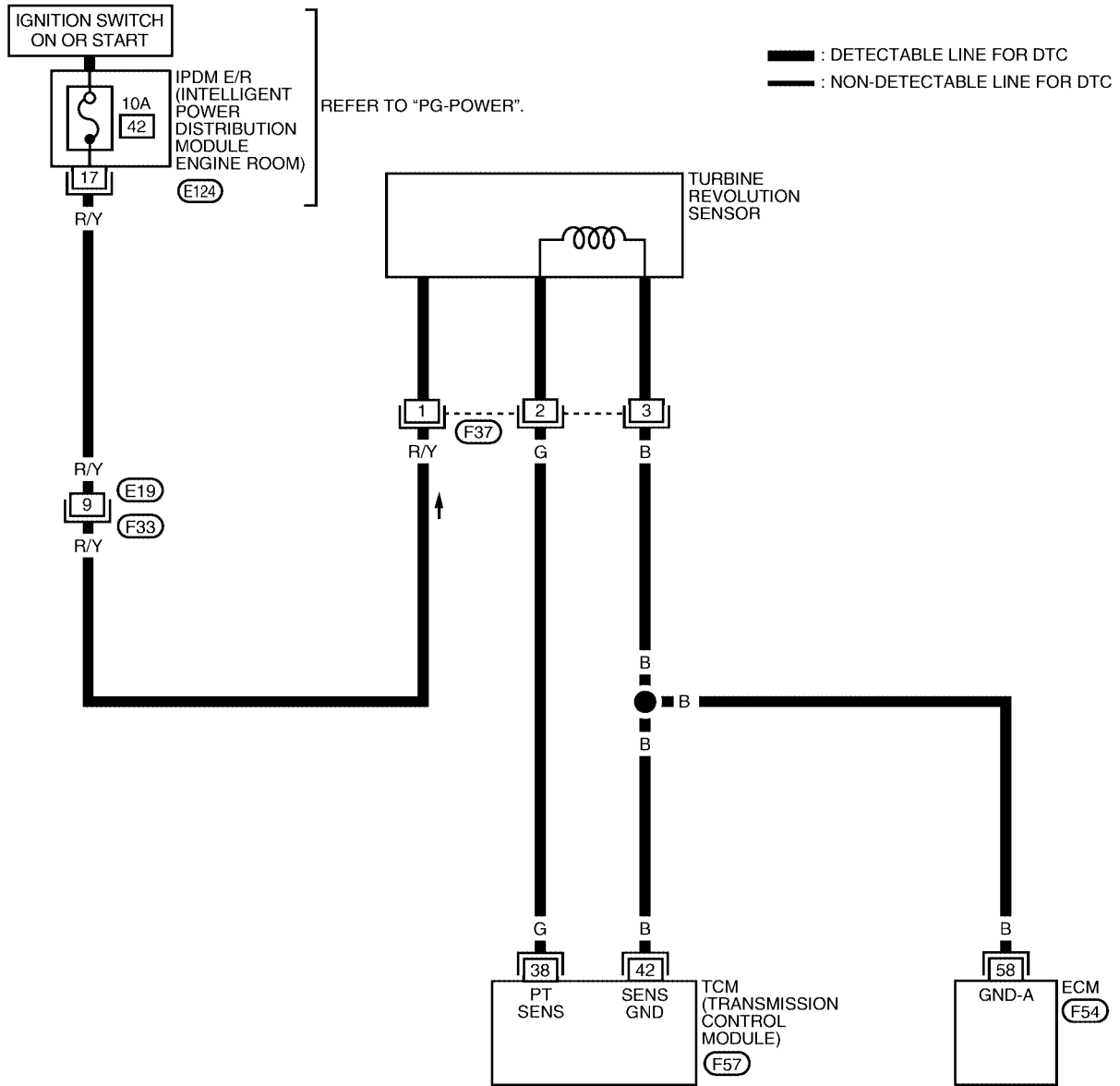

REFER TO THE FOLLOWING.
(F54) - ELECTRICAL UNITS

WCWA0056E

DTC TURBINE REVOLUTION SENSOR

TCM TERMINALS AND REFERENCE VALUE MEASURED BETWEEN EACH TERMINAL AND 25 OR 48 (TCM GROUND)

TERMINAL	WIRE COLOR	ITEM	CONDITION	DATA (DC)
38	G	TURBINE REVOLUTION SENSOR (SIGNAL)	WHEN MOVING AT 20 KM/H (12 MPH), USE THE CONSULT-II PULSE FREQUENCY MEASURING FUNCTION.*1	240 Hz
			CAUTION: CONNECT THE DIAGNOSIS DATA LINK CABLE TO THE VEHICLE DIAGNOSIS CONNECTOR. *1: A CIRCUIT TESTER CANNOT BE USED TO TEST THIS ITEM.	
			WHEN VEHICLE IS PARKED.	UNDER 1.3V OR OVER 4.5V
42	B	SENSOR GROUND	—	—

Diagnostic Procedure

ECS006DX

1. CHECK INPUT SIGNAL

With CONSULT-II

1. Start engine.
2. Select "TCM INPUT SIGNALS" in "DATA MONITOR" mode for "A/T" with CONSULT-II.
3. Read out the value of "TURBINE REV" while driving. Check the value changes according to driving speed.

DATA MONITOR	
MONITORING	
ENGINE SPEED	XXX rpm
TURBINE REV	XXX rpm
OVERDRIVE SW	ON
PN POSI SW	OFF
R POSITION SW	OFF

SAT740J

Without CONSULT-II

1. Start engine.
2. Check frequency between TCM terminal 38 and ground.

Frequency : Approximately 240 Hz when driving 20 km/h (12 MPH)

OK or NG

- OK >> GO TO 3.
 NG >> GO TO 2.

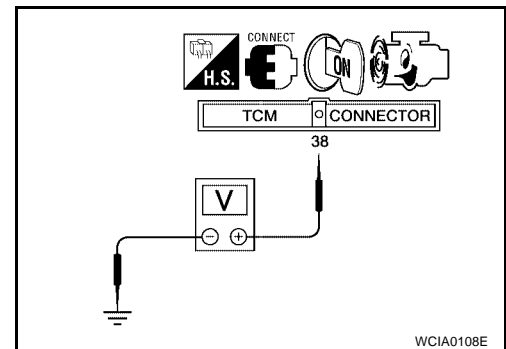

2. DETECT MALFUNCTIONING ITEM

Check harness for short or open between TCM and turbine revolution sensor.

OK or NG

- OK >> GO TO 3.
 NG >> Repair or replace damaged parts.

DTC TURBINE REVOLUTION SENSOR

3. CHECK DTC

Perform [AT-200, "DIAGNOSTIC TROUBLE CODE \(DTC\) CONFIRMATION PROCEDURE"](#) .

OK or NG

- OK >> **INSPECTION END.**
- NG >> GO TO 4.

4. CHECK TCM INSPECTION

1. Perform TCM input/output signal inspection.
2. If NG, recheck TCM pin terminal for damage or loose connection with harness connector.

OK or NG

- OK >> **INSPECTION END.**
- NG >> Repair or replace damaged parts.

Component Inspection TURBINE REVOLUTION SENSOR

ECS006DY

- Check resistance between terminals 1, 2 and 3.

Terminal No.		Resistance (Approx.)
1	2	No continuity
1	3	No continuity
2	3	2.4 - 2.8 kΩ

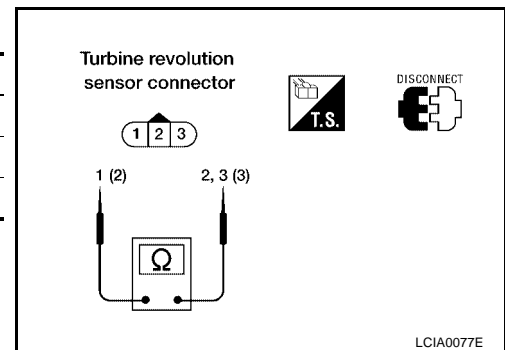

DTC CONTROL UNIT (RAM), CONTROL UNIT (ROM)

DTC CONTROL UNIT (RAM), CONTROL UNIT (ROM)

PFP:31036

Description

ECS006DZ

The TCM consists of a microcomputer and connectors for signal input and output and for power supply. The unit controls the A/T.

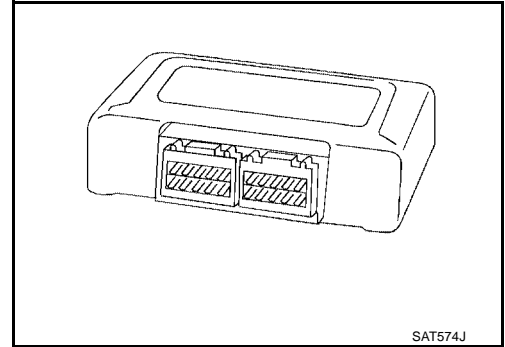

On Board Diagnosis Logic

ECS006E0

Diagnostic trouble code CONTROL UNIT (RAM), CONTROL UNIT (ROM) with CONSULT-II is detected when TCM memory (RAM) or (ROM).

Possible Cause

ECS006E1

Check TCM.

Diagnostic Trouble Code (DTC) Confirmation Procedure

ECS006E2

NOTE:

If "DTC Confirmation Procedure" has been previously conducted, always turn ignition switch OFF and wait at least 10 seconds before conducting the next test.

WITH CONSULT-II

1. Turn ignition switch ON and select "DATA MONITOR" mode for A/T with CONSULT-II.
2. Start engine.

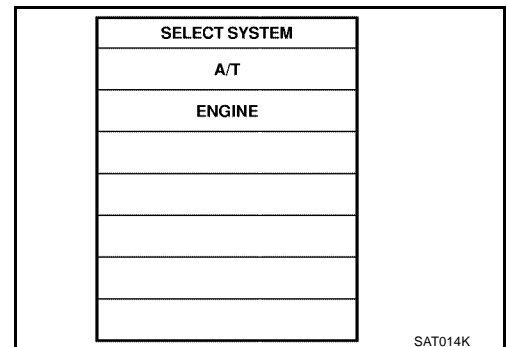

3. Run engine for at least 2 seconds at idle speed.

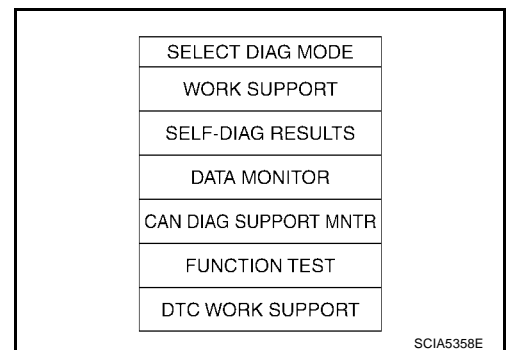

DTC CONTROL UNIT (RAM), CONTROL UNIT (ROM)

Diagnostic Procedure

ECS006E3

1. INSPECTION START

With CONSULT-II

1. Turn ignition switch ON and select "SELF DIAGNOSIS" mode for A/T with CONSULT-II.
2. Touch "ERASE".
3. Perform [AT-205, "Diagnostic Trouble Code \(DTC\) Confirmation Procedure"](#) .
4. Is the "CONTROL UNIT (RAM)" or "CONTROL UNIT (ROM)" displayed again?

Yes or No

Yes >> Replace TCM.

No >> **INSPECTION END**

DTC CONTROL UNIT (EEP ROM)

DTC CONTROL UNIT (EEP ROM)

PF3:31036

ECS006E4

Description

The TCM consists of a microcomputer and connectors for signal input and output and for power supply. The unit controls the A/T.

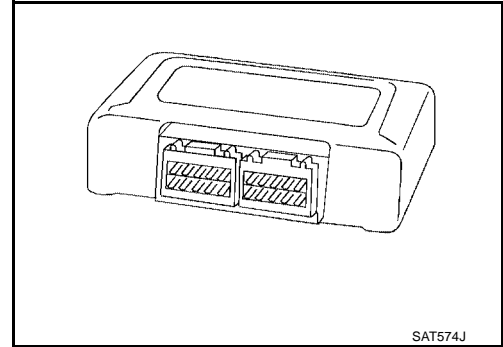

ON BOARD DIAGNOSIS LOGIC

Diagnostic trouble code	Malfunction is detected when ...	Check item (Possible cause)
Ⓜ : CONT UNIT (EEP ROM)	TCM memory (EEP ROM) is malfunctioning.	● TCM

DIAGNOSTIC TROUBLE CODE (DTC) CONFIRMATION PROCEDURE

NOTE:

If "DIAGNOSTIC TROUBLE CODE CONFIRMATION PROCEDURE" has been previously conducted, always turn ignition switch "OFF" and wait at least 5 seconds before conducting the next test.

Ⓜ With CONSULT-II

1. Turn ignition switch "ON" and select "DATA MONITOR" mode for A/T with CONSULT-II.
2. Start engine.
3. Run engine for at least 2 seconds at idle speed.

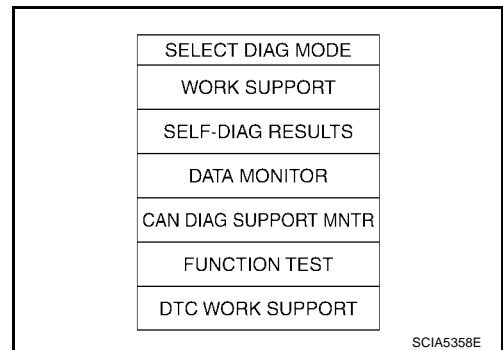
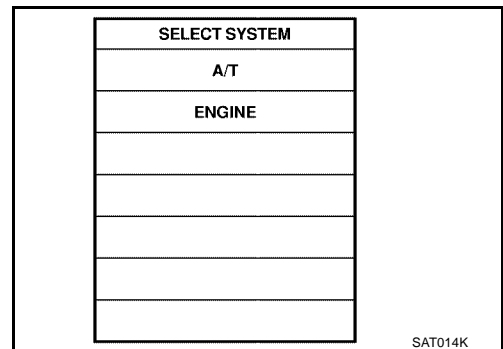

DTC CONTROL UNIT (EEP ROM)

Diagnostic Procedure

ECS006E5

1. CHECK DTC

With CONSULT-II

1. Turn ignition switch "ON" and select "SELF DIAGNOSIS" mode for A/T with CONSULT-II.
2. Move selector lever to "R" position.
3. Depress accelerator pedal (Full throttle position).
4. Touch "ERASE".
5. Turn ignition switch "OFF" position for 10 seconds.

Perform [AT-207, "DIAGNOSTIC TROUBLE CODE \(DTC\) CONFIRMATION PROCEDURE"](#).

Is the "CONT UNIT (EEP ROM)" displayed again?

Yes >> Replace TCM.

No >> **INSPECTION END**

TROUBLE DIAGNOSIS FOR SYMPTOMS

TROUBLE DIAGNOSIS FOR SYMPTOMS

PF0:00007

Wiring Diagram — AT — NONDTC

ECS006E6

AT-NONDTC-01

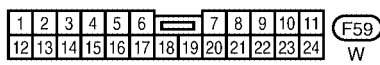
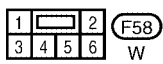
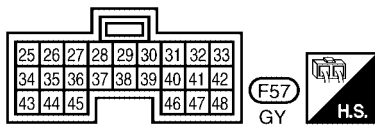
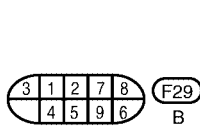
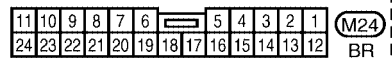
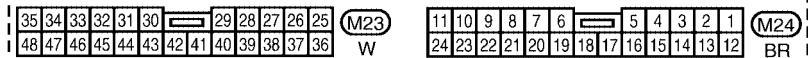
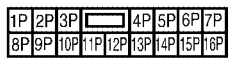
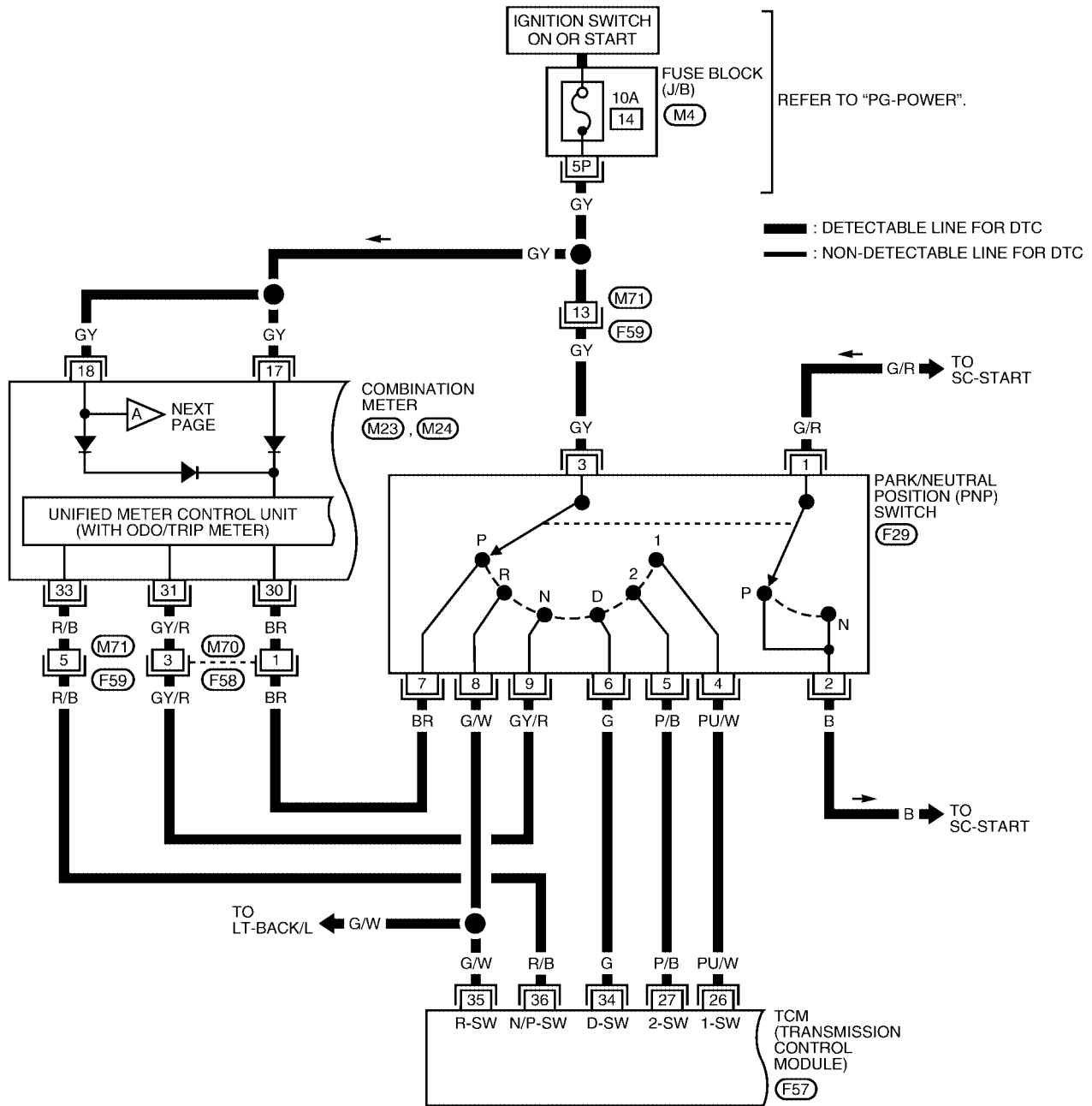

LCWA0025E

TROUBLE DIAGNOSIS FOR SYMPTOMS

TCM TERMINALS AND REFERENCE VALUE MEASURED BETWEEN EACH TERMINAL AND 25 OR 48 (TCM GROUND)

TERMINAL	WIRE COLOR	ITEM	CONDITION	DATA (APPROX.)
26	PU/W	PNP SWITCH 1 POSITION	IGNITION ON AND SELECTOR LEVER IN 1 POSITION	BATTERY VOLTAGE
			IGNITION ON AND SELECTOR LEVER IN OTHER POSITIONS	0V
27	P/B	PNP SWITCH 2 POSITION	IGNITION ON AND SELECTOR LEVER IN 2 POSITION	BATTERY VOLTAGE
			IGNITION ON AND SELECTOR LEVER IN OTHER POSITIONS	0V
34	G	PNP SWITCH D POSITION	IGNITION ON AND SELECTOR LEVER IN D POSITION	BATTERY VOLTAGE
			IGNITION ON AND SELECTOR LEVER IN OTHER POSITIONS	0V
35	G/W	PNP SWITCH R POSITION	IGNITION ON AND SELECTOR LEVER IN R POSITION	BATTERY VOLTAGE
			IGNITION ON AND SELECTOR LEVER IN OTHER POSITIONS	0V
36	R/B	PNP SWITCH P OR N POSITION	IGNITION ON AND SELECTOR LEVER IN P OR N POSITION	BATTERY VOLTAGE
			IGNITION ON AND SELECTOR LEVER IN OTHER POSITIONS	0V

TROUBLE DIAGNOSIS FOR SYMPTOMS

AT-NONDTC-02

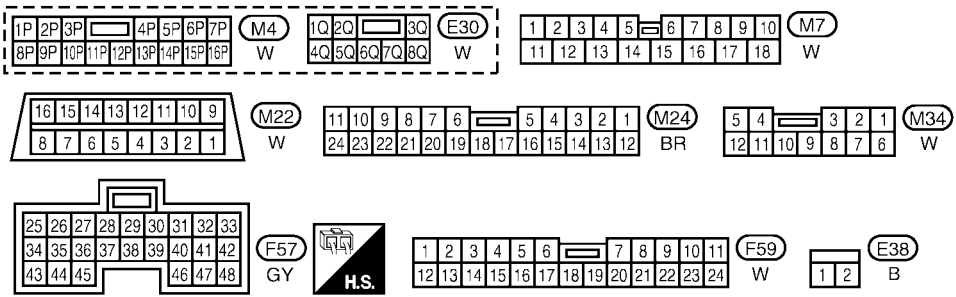
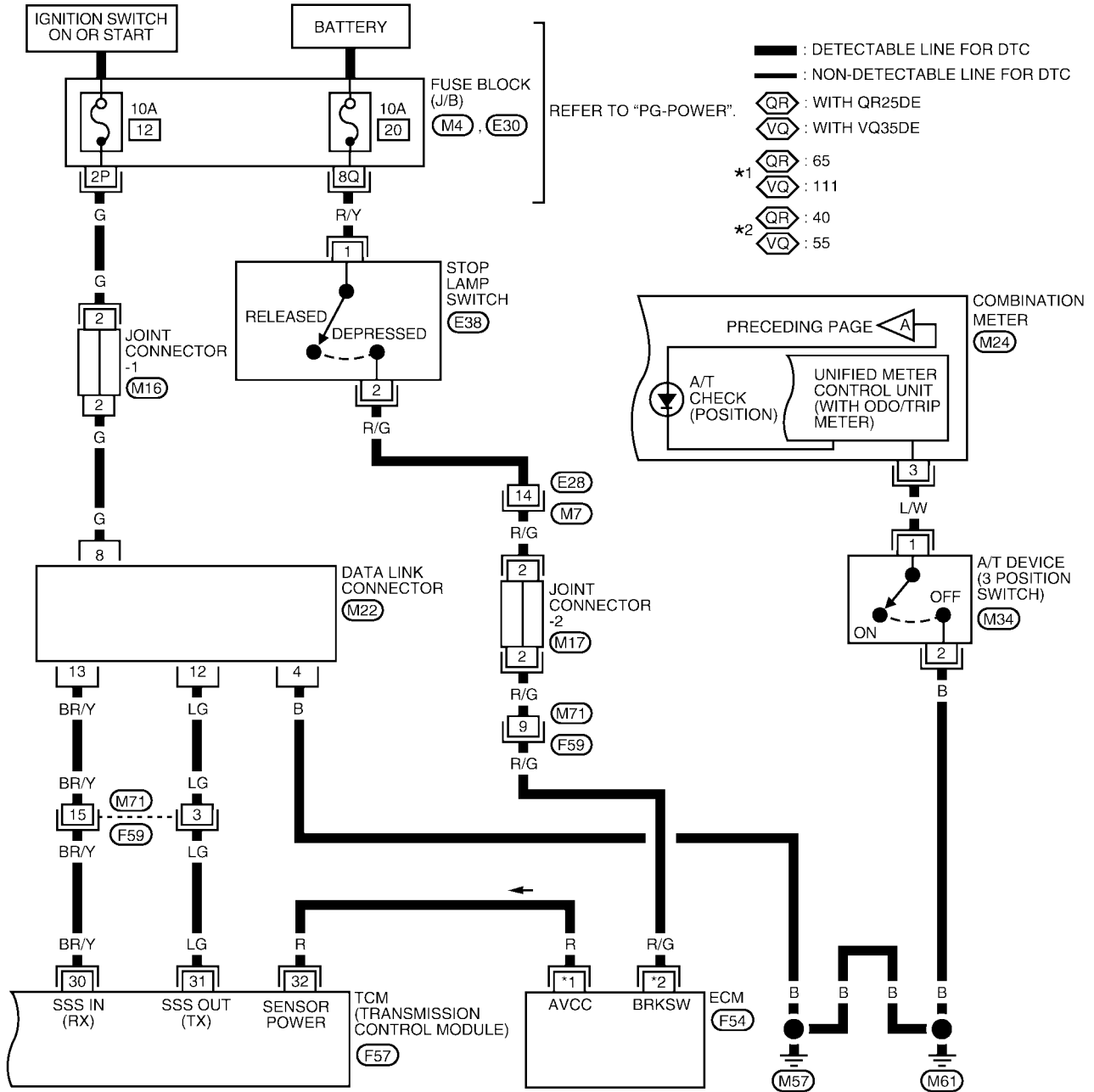

REFER TO THE FOLLOWING.
 (M16), (M17) - JOINT CONNECTOR (J/C)
 (F54) - ELECTRICAL UNITS

WCWA0057E

TROUBLE DIAGNOSIS FOR SYMPTOMS

TCM TERMINALS AND REFERENCE VALUE MEASURED BETWEEN EACH TERMINAL AND 25 OR 48 (TCM GROUND)				
TERMINAL	WIRE COLOR	ITEM	CONDITION	DATA (APPROX.)
30	BR/Y	DATA LINK CONNECTOR	—	—
31	LG	DATA LINK CONNECTOR	—	—
32	R	SENSOR POWER	IGNITION SWITCH ON	4.5 - 5.5V
			IGNITION SWITCH OFF	0V

TROUBLE DIAGNOSIS FOR SYMPTOMS

1. A/T Check (Position) Indicator Lamp Does Not Come On

ECS006E7

SYMPTOM:

A/T check (position) indicator lamp does not come on for about 2 seconds when turning ignition switch to ON.

1. CHECK TCM POWER SOURCE

1. Turn ignition switch to ON position.
(Do not start engine.)
2. Check voltage between TCM terminals 10 (R/Y), 19 (R/Y), and 28 (Y/R) and ground.

Voltage : **Battery voltage**

OK or NG

- OK >> GO TO 2.
NG >> GO TO 3.

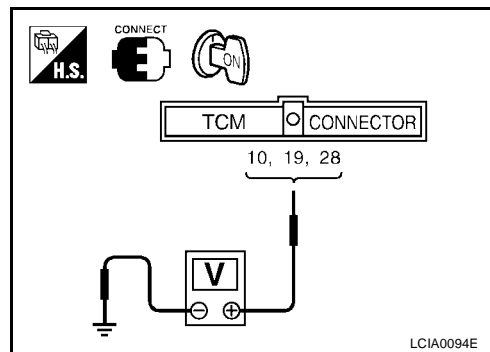

2. CHECK POWER SOURCE STEP 2

1. Turn ignition switch to OFF position.
2. Check voltage between TCM terminal 28 (Y/R) and ground.

Voltage : **Battery voltage**

OK or NG

- OK >> GO TO 4.
NG >> GO TO 3.

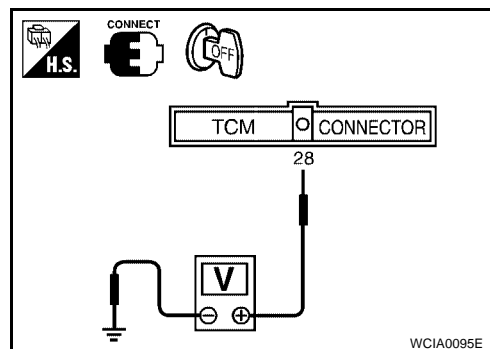

3. DETECT MALFUNCTIONING ITEM

Check the following items:

- Harness for short or open between ignition switch and TCM (Main harness)
Refer to [AT-100, "Wiring Diagram — AT — MAIN"](#) .
- Ignition switch and fuse
Refer to [PG-3, "POWER SUPPLY ROUTING CIRCUIT"](#) .

OK or NG

- OK >> GO TO 4.
NG >> Repair or replace damaged parts.

TROUBLE DIAGNOSIS FOR SYMPTOMS

4. CHECK TCM GROUND CIRCUIT

1. Turn ignition switch to OFF position.
2. Disconnect TCM harness connector.
3. Check continuity between TCM harness connector terminals 25, 48 and ground.

Continuity should exist.

OK or NG

OK >> GO TO 5.

NG >> Repair open circuit or short to ground or short to power in harness or connectors. Refer to [AT-100, "Wiring Diagram — AT — MAIN"](#).

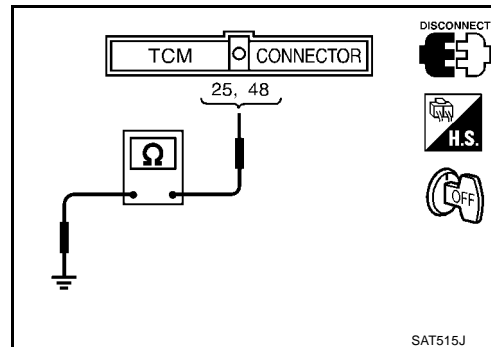

5. DETECT MALFUNCTIONING ITEM

Check the following items:

- Harness and fuse for short or open between ignition switch and A/T check (position) indicator lamp (Main harness)
Refer to [PG-3, "POWER SUPPLY ROUTING CIRCUIT"](#).
- Harness for short or open between A/T check (position) indicator lamp and TCM

OK or NG

OK >> GO TO 6.

NG >> Repair or replace damaged parts.

6. CHECK SYMPTOM

Check again.

OK or NG

OK >> **INSPECTION END**

NG >> GO TO 8.

7. CHECK TCM INSPECTION

1. Perform TCM input/output signal inspection.
2. If NG, recheck TCM pin terminals for damage or loose connection with harness connector.

OK or NG

OK >> **INSPECTION END**

NG >> Repair or replace damaged parts.

TROUBLE DIAGNOSIS FOR SYMPTOMS

ECS006E8

2. Engine Cannot Be Started In P and N Position

SYMPTOM:

- Engine cannot be started with selector lever in P or N position.
- Engine can be started with selector lever in D, 2, 1 or R position.

1. CHECK PARK/NEUTRAL POSITION (PNP) SWITCH CIRCUIT

With CONSULT-II

Does "TCM INPUT SIGNALS" in "DATA MONITOR" show damage to park/neutral position (PNP) switch circuit?

Without CONSULT-II

Does self-diagnosis show damage to park/neutral position (PNP) switch circuit?

Yes or No

- Yes >> Check park/neutral position (PNP) switch circuit. Refer to [AT-103, "DTC P0705 PARK/NEUTRAL POSITION SWITCH"](#).
- No >> GO TO 2.

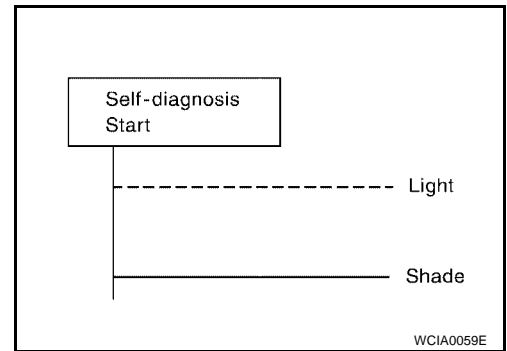

2. CHECK PARK/NEUTRAL POSITION (PNP) SWITCH

Check for short or open of park/neutral position (PNP) switch harness connector terminals 1 and 2. Refer to [SC-19, "DIAGNOSTIC PROCEDURE 2"](#).

OK or NG

- OK >> GO TO 3.
- NG >> Repair or replace park/neutral position (PNP) switch.

3. CHECK STARTING SYSTEM

Check starting system. Refer to [SC-17, "WORK FLOW"](#).

OK or NG

- OK >> **INSPECTION END**
- NG >> Repair or replace damaged parts.

TROUBLE DIAGNOSIS FOR SYMPTOMS

3. In P Position, Vehicle Moves Forward or Backward When Pushed

ECS006E9

SYMPTOM:

Vehicle moves when it is pushed forward or backward with selector lever in P position.

1. CHECK PARKING COMPONENTS

Check parking components. Refer to [AT-272, "OVERHAUL"](#) and [AT-277, "DISASSEMBLY"](#).

OK or NG

- OK >> **INSPECTION END**
- NG >> Repair or replace damaged parts.

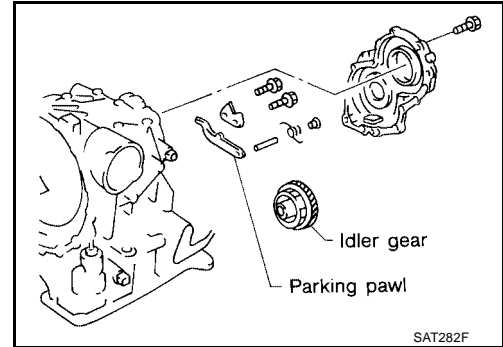

TROUBLE DIAGNOSIS FOR SYMPTOMS

ECS006EA

4. In N Position, Vehicle Moves

SYMPTOM:

Vehicle moves forward or backward when selecting N position.

1. CHECK PARK/NEUTRAL POSITION (PNP) SWITCH CIRCUIT

With CONSULT-II

Does "TCM INPUT SIGNALS" in "DATA MONITOR" show damage to park/neutral position (PNP) switch circuit?

Without CONSULT-II

Does self-diagnosis show damage to park/neutral position (PNP) switch circuit?

Yes or No

- Yes >> Check park/neutral position (PNP) switch circuit. Refer to [AT-103, "DTC P0705 PARK/NEUTRAL POSITION SWITCH"](#).
- No >> GO TO 2.

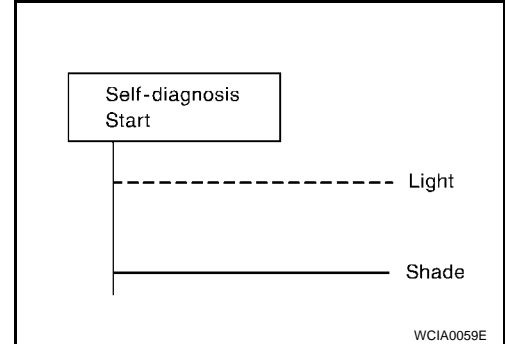

2. CHECK CONTROL LINKAGE

Check control cable. Refer to [AT-263, "Control Cable"](#).

OK or NG

- OK >> GO TO 4.
- NG >> GO TO 3.

3. ADJUST CONTROL CABLE

Adjust control cable.

- >> Refer to [AT-267, "Control Cable Adjustment"](#).

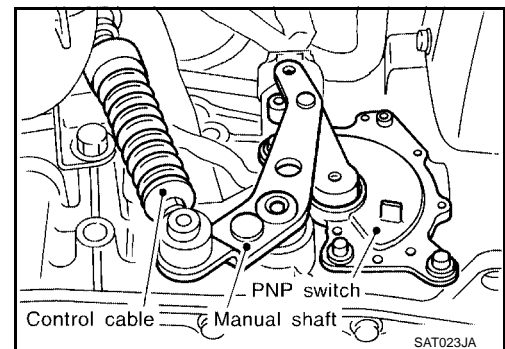

4. CHECK A/T FLUID LEVEL

Check A/T fluid level again.

OK or NG

- OK >> GO TO 5.
- NG >> Refill ATF.

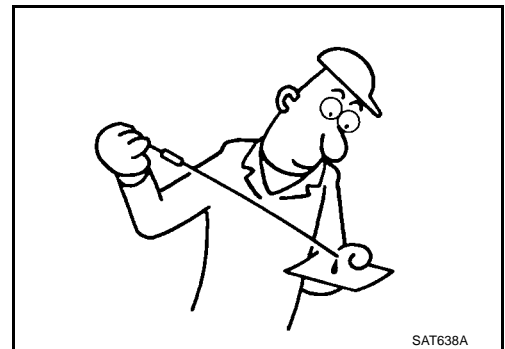

TROUBLE DIAGNOSIS FOR SYMPTOMS

5. CHECK A/T FLUID CONDITION

1. Remove oil pan.
2. Check A/T fluid condition.

OK or NG

- OK >> GO TO 7.
NG >> GO TO 6.

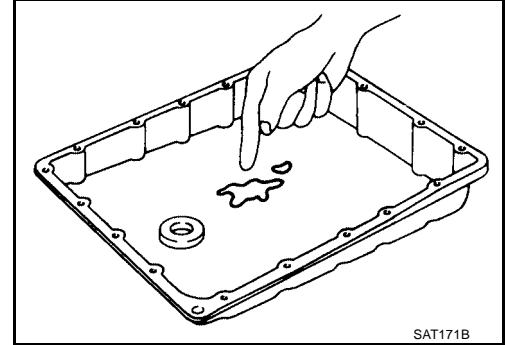

6. DETECT MALFUNCTIONING ITEM

1. Disassemble A/T.
2. Check the following items:
 - Forward clutch assembly
 - Overrun clutch assembly
 - Reverse clutch assembly

OK or NG

- OK >> GO TO 7.
NG >> Repair or replace damaged parts.

7. CHECK SYMPTOM

Check again.

OK or NG

- OK >> **INSPECTION END**
NG >> GO TO 8.

8. CHECK TCM INSPECTION

1. Perform TCM input/output signal inspection.
2. If NG, recheck TCM pin terminals for damage or loose connection with harness connector.

OK or NG

- OK >> **INSPECTION END**
NG >> Repair or replace damaged parts.

TROUBLE DIAGNOSIS FOR SYMPTOMS

5. Large Shock. N → R Position

ECS006EB

SYMPTOM:

There is large shock when changing from N to R position.

1. CHECK SELF-DIAGNOSTIC RESULTS

Does self-diagnosis show damage to A/T fluid temperature sensor, line pressure solenoid valve or throttle position sensor [accelerator pedal position (APP) sensor] circuit?

Yes or No

- Yes >> GO TO 2.
- No >> GO TO 3.

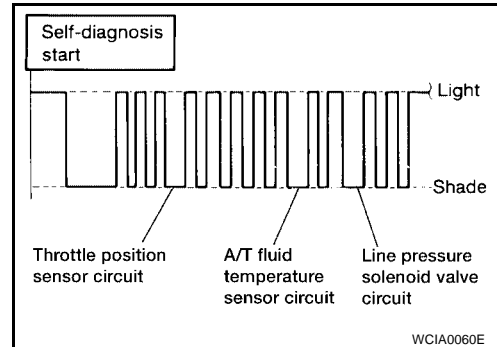

2. CHECK DAMAGED CIRCUIT

Check damaged circuit.

- >> Refer to [AT-109, "DTC P0710 A/T FLUID TEMPERATURE SENSOR CIRCUIT"](#) , [AT-159, "DTC P0745 LINE PRESSURE SOLENOID VALVE"](#) or [AT-175, "DTC P1705 THROTTLE POSITION SENSOR \[ACCELERATOR PEDAL POSITION \(APP\) SENSOR\]"](#) .

3. CHECK THROTTLE POSITION SENSOR [ACCELERATOR PEDAL POSITION (APP) SENSOR]

Check throttle position sensor [accelerator pedal position (APP) sensor]. Refer to [EC-178, "DTC P0122, P0123 TP SENSOR"](#) and [EC-534, "DTC P2122, P2123 APP SENSOR"](#) (with QR25DE), or [EC-822, "DTC P0122, P0123 TP SENSOR"](#) and [EC-1209, "DTC P2122, P2123 APP SENSOR"](#) (with VQ35DE).

OK or NG

- OK >> GO TO 4.
- NG >> Repair or replace throttle position sensor [accelerator pedal position (APP) sensor].

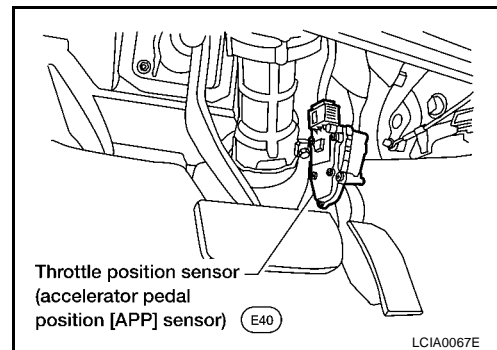

4. CHECK LINE PRESSURE

Check line pressure at idle with selector lever in D position. Refer to [AT-65, "Line Pressure Test"](#) .

OK or NG

- OK >> GO TO 6.
- NG >> GO TO 5.

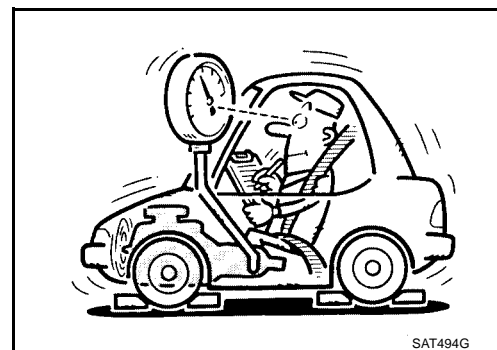

TROUBLE DIAGNOSIS FOR SYMPTOMS

5. DETECT MALFUNCTIONING ITEM

1. Remove control valve assembly. Refer to [AT-264, "Control Valve Assembly and Accumulators"](#) .
2. Check the following items:
 - Valves to control line pressure (Pressure regulator valve, pressure modifier valve, pilot valve and pilot filter)
 - Line pressure solenoid valve

OK or NG

OK >> GO TO 6.

NG >> Repair or replace damaged parts.

6. CHECK SYMPTOM

Check again.

OK or NG

OK >> **INSPECTION END**

NG >> GO TO 7.

7. CHECK TCM INSPECTION

1. Perform TCM input/output signal inspection.
2. If NG, recheck TCM pin terminals for damage or loose connection with harness connector.

OK or NG

OK >> **INSPECTION END**

NG >> Repair or replace damaged parts.

TROUBLE DIAGNOSIS FOR SYMPTOMS

6. Vehicle Does Not Creep Backward In R Position

ECS006EC

SYMPTOM:

Vehicle does not creep backward when selecting R position.

1. CHECK A/T FLUID LEVEL

Check A/T fluid level again.

OK or NG

- OK >> GO TO 2.
- NG >> Refill ATF.

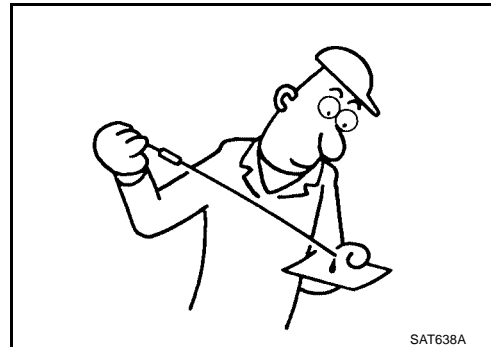

2. CHECK STALL REVOLUTION

Check stall revolution with selector lever in 1 and R positions.

OK or NG

- OK >> GO TO 5.
- OK in 1 position, NG in R position >> GO TO 3.
- NG in both 1 and R positions >> GO TO 4.

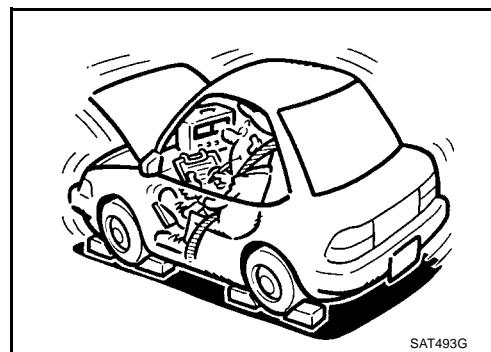

3. DETECT MALFUNCTIONING ITEM

1. Remove control valve assembly. Refer to [AT-264, "Control Valve Assembly and Accumulators"](#).
2. Check the following items:
 - Valves to control line pressure (Pressure regulator valve, pressure modifier valve, pilot valve and pilot filter)
 - Line pressure solenoid valve
3. Disassemble A/T.
4. Check the following items:
 - Oil pump assembly
 - Torque converter
 - Reverse clutch assembly
 - High clutch assembly

OK or NG

- OK >> GO TO 5.
- NG >> Repair or replace damaged parts.

TROUBLE DIAGNOSIS FOR SYMPTOMS

4. DETECT MALFUNCTIONING ITEM

1. Remove control valve assembly. Refer to [AT-264, "Control Valve Assembly and Accumulators"](#) .
2. Check the following items:
 - Valves to control line pressure (Pressure regulator valve, pressure modifier valve, pilot valve and pilot filter)
 - Line pressure solenoid valve
3. Disassemble A/T.
4. Check the following items:
 - Oil pump assembly
 - Torque converter
 - Reverse clutch assembly
 - High clutch assembly
 - Low & reverse brake assembly
 - Low one-way clutch

OK or NG

OK >> GO TO 5.

NG >> Repair or replace damaged parts.

5. CHECK LINE PRESSURE

Check line pressure at idle with selector lever in R position. Refer to [AT-65, "Line Pressure Test"](#) .

OK or NG

OK >> GO TO 7.

NG >> GO TO 6.

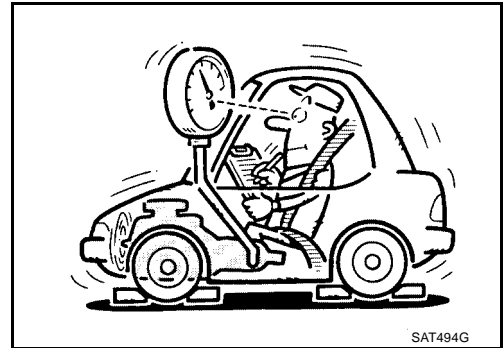

SAT494G

6. DETECT MALFUNCTIONING ITEM

1. Remove control valve assembly. Refer to [AT-264, "Control Valve Assembly and Accumulators"](#) .
2. Check the following items:
 - Valves to control line pressure (Pressure regulator valve, pressure modifier valve, pilot valve and pilot filter)
 - Line pressure solenoid valve
3. Disassemble A/T.
4. Check the following item:
 - Oil pump assembly

OK or NG

OK >> GO TO 7.

NG >> Repair or replace damaged parts.

TROUBLE DIAGNOSIS FOR SYMPTOMS

7. CHECK A/T FLUID CONDITION

1. Remove oil pan.
2. Check A/T fluid condition.

OK or NG

- OK >> GO TO 9.
NG >> GO TO 8.

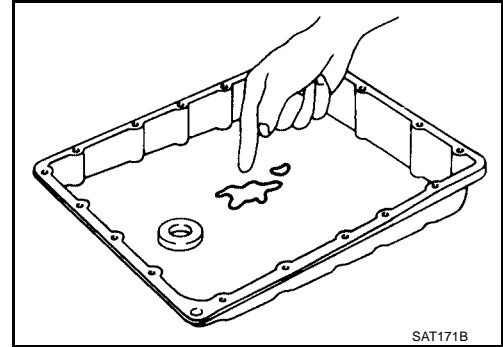

8. DETECT MALFUNCTIONING ITEM

1. Remove control valve assembly. Refer to [AT-264, "Control Valve Assembly and Accumulators"](#).
2. Check the following items:
 - Valves to control line pressure (Pressure regulator valve, pressure modifier valve, pilot valve and pilot filter)
 - Line pressure solenoid valve
3. Disassemble A/T.
4. Check the following items:
 - Oil pump assembly
 - Torque converter
 - Reverse clutch assembly
 - High clutch assembly
 - Low & reverse brake assembly
 - Low one-way clutch

OK or NG

- OK >> GO TO 9.
NG >> Repair or replace damaged parts.

9. CHECK SYMPTOM

Check again.

OK or NG

- OK >> **INSPECTION END**
NG >> GO TO 10.

10. CHECK TCM INSPECTION

1. Perform TCM input/output signal inspection.
2. If NG, recheck TCM pin terminals for damage or loose connection with harness connector.

OK or NG

- OK >> **INSPECTION END**
NG >> Repair or replace damaged parts.

TROUBLE DIAGNOSIS FOR SYMPTOMS

ECS006ED

7. Vehicle Does Not Creep Forward in D, 3, 2 or 1 Position

SYMPTOM:

Vehicle does not creep forward when selecting D, 3, 2 or 1 position.

1. CHECK A/T FLUID LEVEL

Check A/T fluid level again.

OK or NG

- OK >> GO TO 2.
- NG >> Refill ATF.

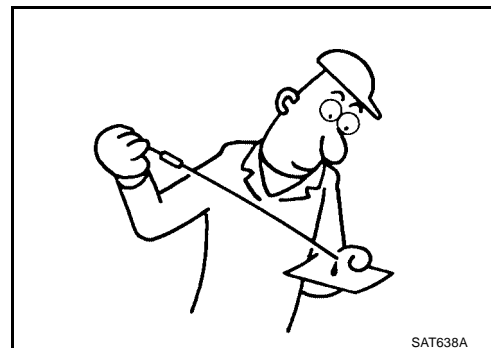

2. CHECK STALL REVOLUTION

Check stall revolution with selector lever in D position. Refer to [AT-61, "Stall Test"](#).

OK or NG

- OK >> GO TO 4.
- NG >> GO TO 3.

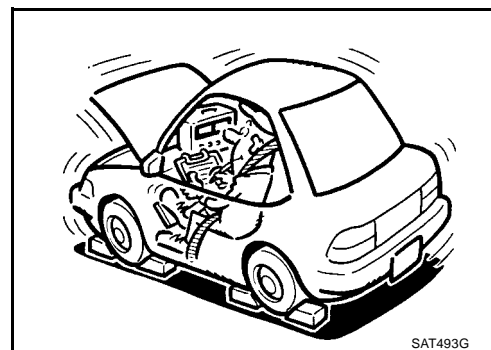

3. DETECT MALFUNCTIONING ITEM

1. Remove control valve assembly. Refer to [AT-264, "Control Valve Assembly and Accumulators"](#).
2. Check the following items:
 - Valves to control line pressure (Pressure regulator valve, pressure modifier valve, pilot valve and pilot filter)
 - Line pressure solenoid valve
3. Disassemble A/T.
4. Check the following items:
 - Oil pump assembly
 - Forward clutch assembly
 - Forward one-way clutch
 - Low one-way clutch
 - Low & reverse brake assembly
 - Torque converter

OK or NG

- OK >> GO TO 4.
- NG >> Repair or replace damaged parts.

TROUBLE DIAGNOSIS FOR SYMPTOMS

4. CHECK LINE PRESSURE

Check line pressure at idle with selector lever in D position. Refer to [AT-65, "Line Pressure Test"](#) .

OK or NG

- OK >> GO TO 6.
- NG >> GO TO 5.

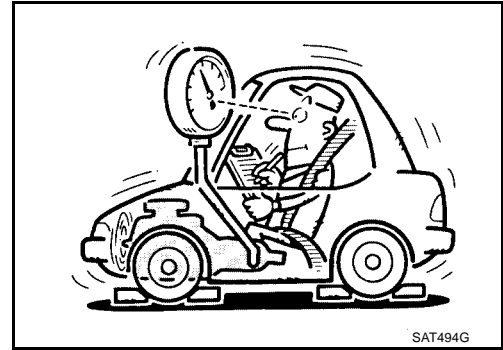

5. DETECT MALFUNCTIONING ITEM

1. Remove control valve assembly. Refer to [AT-264, "Control Valve Assembly and Accumulators"](#) .
2. Check the following items:
 - Valves to control line pressure (Pressure regulator valve, pressure modifier valve, pilot valve and pilot filter)
 - Line pressure solenoid valve
3. Disassemble A/T.
4. Check the following item:
 - Oil pump assembly

OK or NG

- OK >> GO TO 6.
- NG >> Repair or replace damaged parts.

6. CHECK A/T FLUID CONDITION

1. Remove oil pan.
2. Check A/T fluid condition.

OK or NG

- OK >> GO TO 8.
- NG >> GO TO 7.

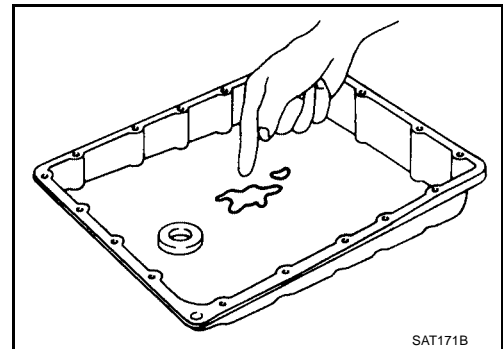

TROUBLE DIAGNOSIS FOR SYMPTOMS

7. DETECT MALFUNCTIONING ITEM

1. Remove control valve assembly. Refer to [AT-264, "Control Valve Assembly and Accumulators"](#) .
2. Check the following items:
 - Valves to control line pressure (Pressure regulator valve, pressure modifier valve, pilot valve and pilot filter)
 - Line pressure solenoid valve
3. Disassemble A/T.
4. Check the following items:
 - Oil pump assembly
 - Forward clutch assembly
 - Forward one-way clutch
 - Low one-way clutch
 - Low & reverse brake assembly
 - Torque converter

OK or NG

- OK >> GO TO 8.
NG >> Repair or replace damaged parts.

8. CHECK SYMPTOM

Check again.

OK or NG

- OK >> **INSPECTION END**
NG >> GO TO 9.

9. CHECK TCM INSPECTION

1. Perform TCM input/output signal inspection.
2. If NG, recheck TCM pin terminals for damage or loose connection with harness connector.

OK or NG

- OK >> **INSPECTION END**
NG >> Repair or replace damaged parts.

TROUBLE DIAGNOSIS FOR SYMPTOMS

ECS006EE

8. Vehicle Cannot Be Started From D1

SYMPTOM:

Vehicle cannot be started from D1 on Cruise test — Part 1.

1. CHECK SYMPTOM

Is "6. Vehicle Does Not Creep Backward In R Position" OK?

Yes or No

Yes >> GO TO 2.

No >> Go to [AT-221, "6. Vehicle Does Not Creep Backward In R Position"](#).

2. CHECK SELF-DIAGNOSTIC RESULTS

Does self-diagnosis show damage to vehicle speed sensor-A/T (revolution sensor), shift solenoid valve A, B or vehicle speed sensor-MTR after cruise test?

Yes or No

Yes >> Check damaged circuit. Refer to [AT-115, "DTC P0720 VEHICLE SPEED SENSOR-A/T \(REVOLUTION SENSOR\)"](#), [AT-165, "DTC P0750 SHIFT SOLENOID VALVE A"](#), [AT-170, "DTC P0755 SHIFT SOLENOID VALVE B"](#) or [AT-196, "DTC VEHICLE SPEED SENSOR MTR"](#).

No >> GO TO 3.

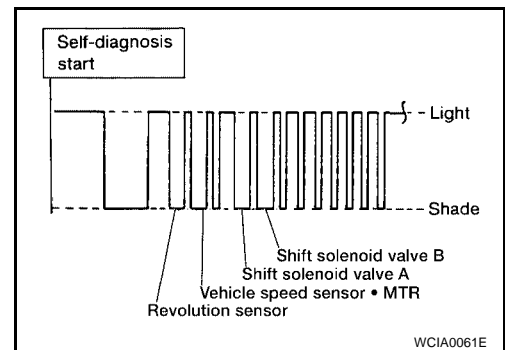

3. CHECK THROTTLE POSITION SENSOR [ACCELERATOR PEDAL POSITION (APP) SENSOR]

Check throttle position sensor [accelerator pedal position (APP) sensor]. Refer to [EC-178, "DTC P0122, P0123 TP SENSOR"](#) and [EC-534, "DTC P2122, P2123 APP SENSOR"](#) (with QR25DE), or [EC-822, "DTC P0122, P0123 TP SENSOR"](#) and [EC-1209, "DTC P2122, P2123 APP SENSOR"](#) (with VQ35DE).

OK or NG

OK >> GO TO 4.

NG >> Repair or replace throttle position sensor [accelerator pedal position (APP) sensor].

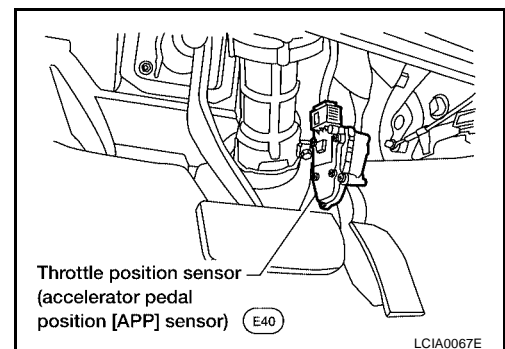

4. CHECK LINE PRESSURE

Check line pressure at stall point with selector lever in D position. Refer to [AT-65, "Line Pressure Test"](#).

OK or NG

OK >> GO TO 6.

NG >> GO TO 5.

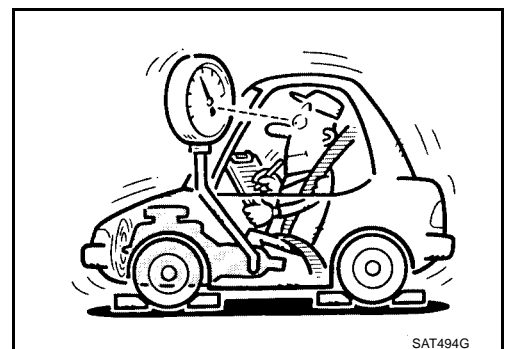

TROUBLE DIAGNOSIS FOR SYMPTOMS

5. DETECT MALFUNCTIONING ITEM

1. Remove control valve assembly. Refer to [AT-264, "Control Valve Assembly and Accumulators"](#) .
2. Check the following items:
 - Shift valve A
 - Shift valve B
 - Shift solenoid valve A
 - Shift solenoid valve B
 - Pilot valve
 - Pilot filter
3. Disassemble A/T.
4. Check the following items:
 - Forward clutch assembly
 - Forward one-way clutch
 - Low one-way clutch
 - High clutch assembly
 - Torque converter
 - Oil pump assembly

OK or NG

- OK >> GO TO 8.
NG >> Repair or replace damaged parts.

6. CHECK A/T FLUID CONDITION

1. Remove oil pan.
2. Check A/T fluid condition.

OK or NG

- OK >> GO TO 7.
NG >> GO TO 5.

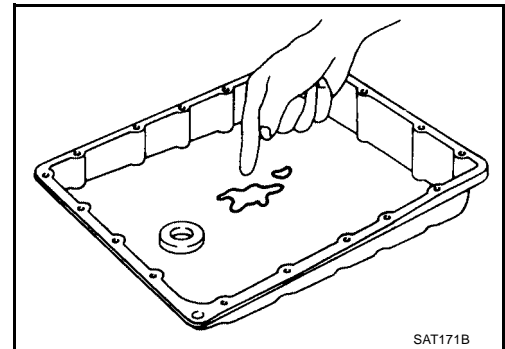

7. DETECT MALFUNCTIONING ITEM

1. Remove control valve assembly. Refer to [AT-264, "Control Valve Assembly and Accumulators"](#) .
2. Check the following items:
 - Shift valve A
 - Shift valve B
 - Shift solenoid valve A
 - Shift solenoid valve B
 - Pilot valve
 - Pilot filter

OK or NG

- OK >> GO TO 8.
NG >> Repair or replace damage parts.

TROUBLE DIAGNOSIS FOR SYMPTOMS

8. CHECK SYMPTOM

Check again.

OK or NG

OK >> **INSPECTION END**

NG >> GO TO 9.

9. CHECK TCM INSPECTION

1. Perform TCM input/output signal inspection.
2. If NG, recheck TCM pin terminals for damage or loose connection with harness connector.

OK or NG

OK >> **INSPECTION END**

NG >> Repair or replace damaged parts.

A

B

AT

D

E

F

G

H

I

J

K

L

M

TROUBLE DIAGNOSIS FOR SYMPTOMS

9. A/T Does Not Shift: D1 → D2 or Does Not Kickdown: D4 → D2

ECS006EF

SYMPTOM:

A/T does not shift from D1 to D2 at the specified speed.

A/T does not shift from D4 to D2 when depressing accelerator pedal fully at the specified speed.

1. CHECK SYMPTOM

Are "7. Vehicle Does Not Creep Forward In D, 3, 2 Or 1 Position" and "8. Vehicle Cannot Be Started From D1" OK?

Yes or No

Yes >> GO TO 2.

No >> Go to [AT-224, "7. Vehicle Does Not Creep Forward in D, 3, 2 or 1 Position"](#) and [AT-227, "8. Vehicle Cannot Be Started From D1"](#).

2. CHECK SELF-DIAGNOSTIC RESULTS

Ⓜ With CONSULT-II

Does "TCM INPUT SIGNALS" in "DATA MONITOR" show damage to park/neutral position (PNP) switch circuit?

ⓧ Without CONSULT-II

Does self-diagnosis show damage to park/neutral position (PNP) switch circuit?

Yes or No

Yes >> Check park/neutral position (PNP) switch circuit. Refer to [AT-103, "DTC P0705 PARK/NEUTRAL POSITION SWITCH"](#).

No >> GO TO 3.

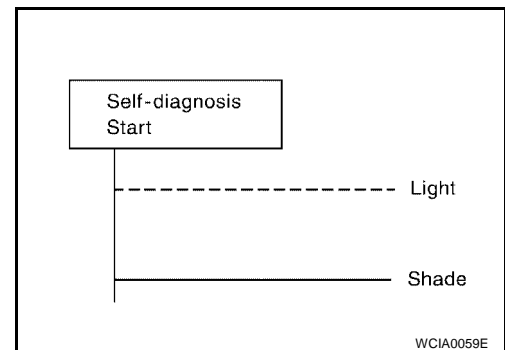

3. CHECK VEHICLE SPEED SENSOR-A/T AND VEHICLE SPEED SENSOR-MTR CIRCUIT

Check vehicle speed sensor-A/T (revolution sensor) and vehicle speed sensor-MTR circuit. Refer to [AT-115, "DTC P0720 VEHICLE SPEED SENSOR-A/T \(REVOLUTION SENSOR\)"](#) and [AT-196, "DTC VEHICLE SPEED SENSOR MTR"](#).

OK or NG

OK >> GO TO 4.

NG >> Repair or replace vehicle speed sensor-A/T (revolution sensor) and vehicle speed sensor-MTR circuits.

4. CHECK THROTTLE POSITION SENSOR [ACCELERATOR PEDAL POSITION (APP) SENSOR]

Check throttle position sensor [accelerator pedal position (APP) sensor]. Refer to [EC-178, "DTC P0122, P0123 TP SENSOR"](#) and [EC-534, "DTC P2122, P2123 APP SENSOR"](#) (with QR25DE), or [EC-822, "DTC P0122, P0123 TP SENSOR"](#) and [EC-1209, "DTC P2122, P2123 APP SENSOR"](#) (with VQ35DE).

OK or NG

OK >> GO TO 5.

NG >> Repair or replace throttle position sensor [accelerator pedal position (APP) sensor].

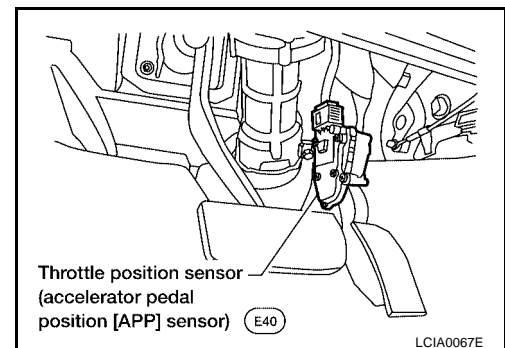

TROUBLE DIAGNOSIS FOR SYMPTOMS

5. CHECK A/T FLUID CONDITION

1. Remove oil pan.
2. Check A/T fluid condition.

OK or NG

- OK >> GO TO 7.
- NG >> GO TO 6.

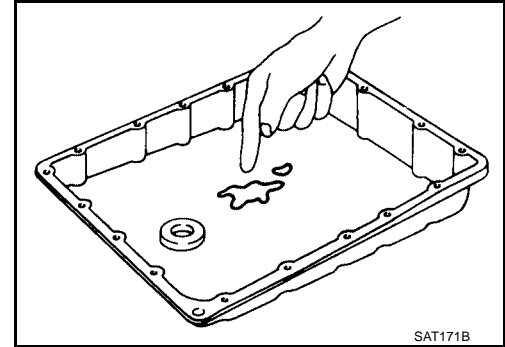

6. DETECT MALFUNCTIONING ITEM

1. Remove control valve. Refer to [AT-264, "Control Valve Assembly and Accumulators"](#) .
2. Check the following items:
 - Shift valve A
 - Shift solenoid valve A
 - Pilot valve
 - Pilot filter
3. Disassemble A/T.
4. Check the following items:
 - Servo piston assembly
 - Brake band
 - Oil pump assembly

OK or NG

- OK >> GO TO 8.
- NG >> Repair or replace damaged parts.

7. DETECT MALFUNCTIONING ITEM

1. Remove control valve. Refer to [AT-264, "Control Valve Assembly and Accumulators"](#) .
2. Check the following items:
 - Shift valve A
 - Shift solenoid valve A
 - Pilot valve
 - Pilot filter

OK or NG

- OK >> GO TO 8.
- NG >> Repair or replace damaged parts.

8. CHECK SYMPTOM

Check again.

OK or NG

- OK >> **INSPECTION END**
- NG >> GO TO 9.

TROUBLE DIAGNOSIS FOR SYMPTOMS

9. CHECK TCM INSPECTION

1. Perform TCM input/output signal inspection.
2. If NG, recheck TCM pin terminals for damage or loose connection with harness connector.

OK or NG

- OK >> **INSPECTION END**
NG >> Repair or replace damaged parts.

TROUBLE DIAGNOSIS FOR SYMPTOMS

10. A/T Does Not Shift: D2 → D3

ECS006EG

SYMPTOM:

A/T does not shift from D2 to D3 at the specified speed.

1. CHECK SYMPTOM

Are 7. Vehicle Does Not Creep Forward In D, 3, 2 Or 1 Position and 8. Vehicle Cannot Be Started From D1 OK?

Yes or No

Yes >> GO TO 2.

No >> Go to [AT-224, "7. Vehicle Does Not Creep Forward in D, 3, 2 or 1 Position"](#) and [AT-227, "8. Vehicle Cannot Be Started From D1"](#).

2. CHECK PARK/NEUTRAL POSITION (PNP) SWITCH CIRCUIT

With CONSULT-II

Does "TCM INPUT SIGNALS" in "DATA MONITOR" show damage to park/neutral position (PNP) switch circuit?

Without CONSULT-II

Does self-diagnosis show damage to park/neutral position (PNP) switch circuit?

Yes or No

Yes >> Check park/neutral position (PNP) switch circuit. Refer to [AT-103, "DTC P0705 PARK/NEUTRAL POSITION SWITCH"](#).

No >> GO TO 3.

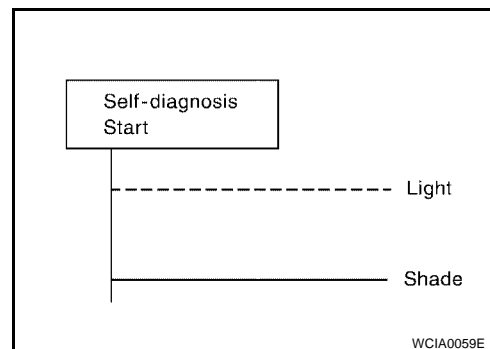

3. CHECK THROTTLE POSITION SENSOR [ACCELERATOR PEDAL POSITION (APP) SENSOR]

Check throttle position sensor [accelerator pedal position (APP) sensor]. Refer to [EC-178, "DTC P0122, P0123 TP SENSOR"](#) and [EC-534, "DTC P2122, P2123 APP SENSOR"](#) (with QR25DE), or [EC-822, "DTC P0122, P0123 TP SENSOR"](#) and [EC-1209, "DTC P2122, P2123 APP SENSOR"](#) (with VQ35DE).

OK or NG

OK >> GO TO 4.

NG >> Repair or replace throttle position sensor [accelerator pedal position (APP) sensor].

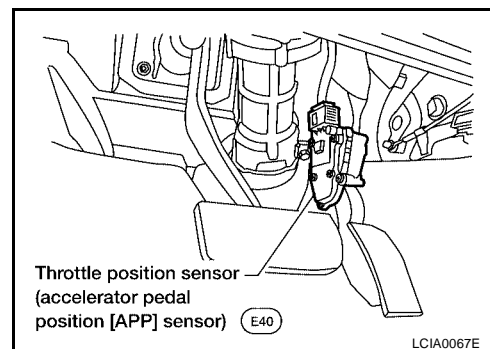

TROUBLE DIAGNOSIS FOR SYMPTOMS

4. CHECK A/T FLUID CONDITION

1. Remove oil pan.
2. Check A/T fluid condition.

OK or NG

- OK >> GO TO 6.
NG >> GO TO 5.

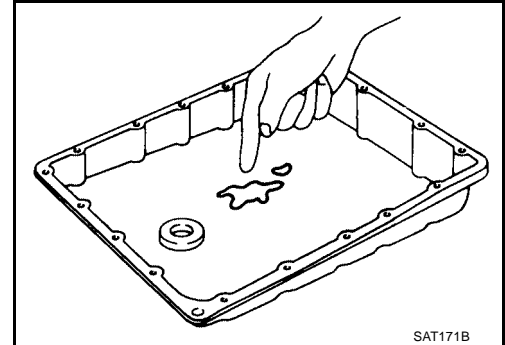

5. DETECT MALFUNCTIONING ITEM

1. Remove control valve assembly. Refer to [AT-264, "Control Valve Assembly and Accumulators"](#).
2. Check the following items:
 - Shift valve B
 - Shift solenoid valve B
 - Pilot valve
 - Pilot filter
3. Disassemble A/T.
4. Check the following items:
 - Servo piston assembly
 - High clutch assembly
 - Oil pump assembly

OK or NG

- OK >> GO TO 7.
NG >> Repair or replace damaged parts.

6. DETECT MALFUNCTIONING ITEM

1. Remove control valve assembly. Refer to [AT-264, "Control Valve Assembly and Accumulators"](#).
2. Check the following items:
 - Shift valve B
 - Shift solenoid valve B
 - Pilot valve
 - Pilot filter

OK or NG

- OK >> GO TO 7.
NG >> Repair or replace damaged parts.

7. CHECK SYMPTOM

Check again.

OK or NG

- OK >> **INSPECTION END**
NG >> GO TO 8.

TROUBLE DIAGNOSIS FOR SYMPTOMS

8. CHECK TCM INSPECTION

1. Perform TCM input/output signal inspection.
2. If NG, recheck TCM pin terminals for damage or loose connection with harness connector.

OK or NG

- OK >> **INSPECTION END**
NG >> Repair or replace damaged parts.

A

B

AT

D

E

F

G

H

I

J

K

L

M

TROUBLE DIAGNOSIS FOR SYMPTOMS

ECS006EH

11. A/T Does Not Shift: D3 → D4

SYMPTOM:

- A/T does not shift from D3 to D4 at the specified speed.
- A/T must be warm before D3 to D4 shift will occur.

1. CHECK SYMPTOM

Are "7. Vehicle Does Not Creep Forward In D, 3, 2 Or 1 Position" and "8. Vehicle Cannot Be Started From D1" OK?

Yes or No

- Yes >> GO TO 2.
- No >> Go to [AT-224, "7. Vehicle Does Not Creep Forward in D, 3, 2 or 1 Position"](#) and [AT-227, "8. Vehicle Cannot Be Started From D1"](#).

2. CHECK SELF-DIAGNOSTIC RESULTS

With CONSULT-II

Does self-diagnosis, after cruise test, show damage to any of the following circuits?

- Park/neutral position (PNP) switch
- Overdrive control switch
- A/T fluid temperature sensor
- Vehicle speed sensor-A/T (revolution sensor)
- Shift solenoid valve A or B

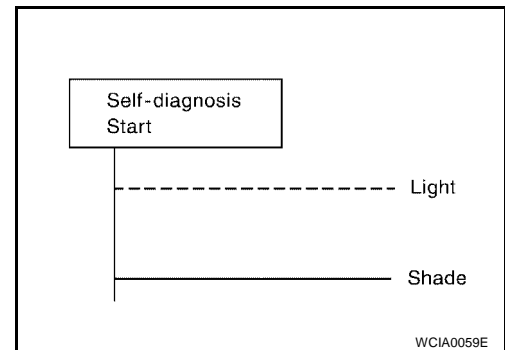

- Vehicle speed sensor-MTR

Yes or No

- Yes >> Check damaged circuit. Refer to [AT-103, "DTC P0705 PARK/NEUTRAL POSITION SWITCH"](#), [AT-109, "DTC P0710 A/T FLUID TEMPERATURE SENSOR CIRCUIT"](#), [AT-115, "DTC P0720 VEHICLE SPEED SENSOR-A/T \(REVOLUTION SENSOR\)"](#), [AT-165, "DTC P0750 SHIFT SOLENOID VALVE A"](#), [AT-170, "DTC P0755 SHIFT SOLENOID VALVE B"](#) or [AT-196, "DTC VEHICLE SPEED SENSOR MTR"](#).
- No >> GO TO 3.

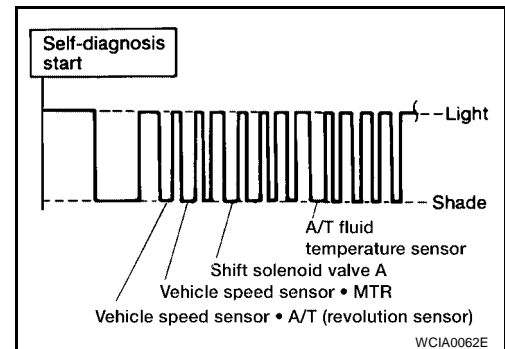

3. CHECK THROTTLE POSITION SENSOR [ACCELERATOR PEDAL POSITION (APP) SENSOR]

Check throttle position sensor [accelerator pedal position (APP) sensor]. Refer to [EC-178, "DTC P0122, P0123 TP SENSOR"](#) and [EC-534, "DTC P2122, P2123 APP SENSOR"](#) (with QR25DE), or [EC-822, "DTC P0122, P0123 TP SENSOR"](#) and [EC-1209, "DTC P2122, P2123 APP SENSOR"](#) (with VQ35DE).

OK or NG

- OK >> GO TO 4.
- NG >> Repair or replace throttle position sensor [accelerator pedal position (APP) sensor].

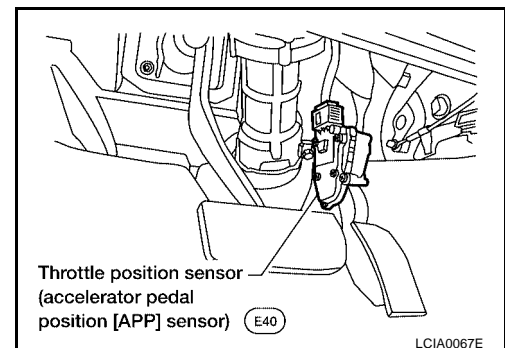

TROUBLE DIAGNOSIS FOR SYMPTOMS

4. CHECK A/T FLUID CONDITION

1. Remove oil pan.
2. Check A/T fluid condition.

OK or NG

- OK >> GO TO 6.
NG >> GO TO 5.

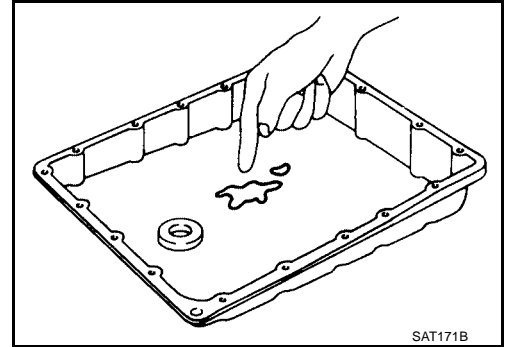

5. DETECT MALFUNCTIONING ITEM

1. Remove control valve assembly. Refer to [AT-264, "Control Valve Assembly and Accumulators"](#).
2. Check the following items:
 - Shift valve B
 - Overrun clutch control valve
 - Shift solenoid valve B
 - Pilot valve
 - Pilot filter
3. Disassemble A/T.
4. Check the following items:
 - Servo piston assembly
 - Brake band
 - Torque converter
 - Oil pump assembly

OK or NG

- OK >> GO TO 7.
NG >> Repair or replace damaged parts.

6. DETECT MALFUNCTIONING ITEM

1. Remove control valve assembly. Refer to [AT-264, "Control Valve Assembly and Accumulators"](#).
2. Check the following items:
 - Shift valve B
 - Overrun clutch control valve
 - Shift solenoid valve B
 - Pilot valve
 - Pilot filter

OK or NG

- OK >> GO TO 7.
NG >> Repair or replace damaged parts.

7. CHECK SYMPTOM

Check again.

OK or NG

- OK >> **INSPECTION END**
NG >> GO TO 8.

TROUBLE DIAGNOSIS FOR SYMPTOMS

8. CHECK TCM INSPECTION

1. Perform TCM input/output signal inspection.
2. If NG, recheck TCM pin terminals for damage or loose connection with harness connector.

OK or NG

- OK >> **INSPECTION END**
NG >> Repair or replace damaged parts.

TROUBLE DIAGNOSIS FOR SYMPTOMS

ECS006E1

12. A/T Does Not Perform Lock-up

SYMPTOM:

A/T does not perform lock-up at the specified speed.

1. CHECK SELF-DIAGNOSTIC RESULTS

Does self-diagnosis show damage to torque converter clutch solenoid valve circuit after cruise test?

Yes or No

- Yes >> Check torque converter clutch solenoid valve circuit. Refer to [AT-146, "DTC P0740 TORQUE CONVERTER CLUTCH SOLENOID VALVE"](#).
- No >> GO TO 2.

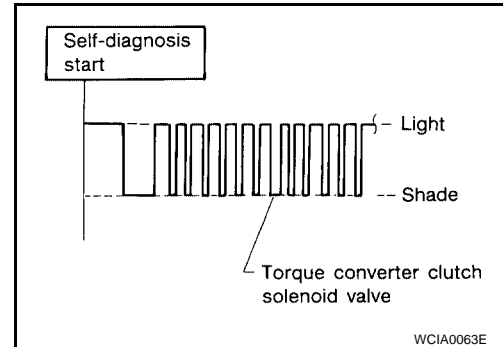

2. CHECK THROTTLE POSITION SENSOR [ACCELERATOR PEDAL POSITION (APP) SENSOR]

Check throttle position sensor [accelerator pedal position (APP) sensor]. Refer to [EC-178, "DTC P0122, P0123 TP SENSOR"](#) and [EC-534, "DTC P2122, P2123 APP SENSOR"](#) (with QR25DE), or [EC-822, "DTC P0122, P0123 TP SENSOR"](#) and [EC-1209, "DTC P2122, P2123 APP SENSOR"](#) (with VQ35DE).

OK or NG

- OK >> GO TO 3.
- NG >> Repair or replace throttle position sensor [accelerator pedal position (APP) sensor].

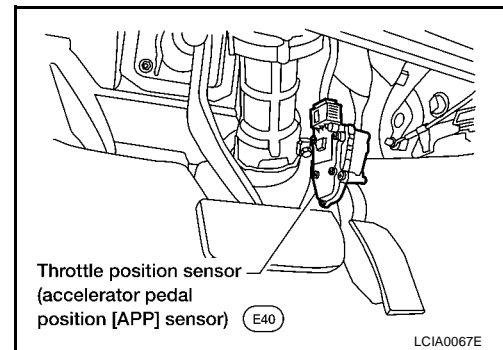

3. DETECT MALFUNCTIONING ITEM

1. Remove control valve. Refer to [AT-264, "Control Valve Assembly and Accumulators"](#).
2. Check following items:
 - Torque converter clutch control valve
 - Torque converter relief valve
 - Torque converter clutch solenoid valve
 - Pilot valve
 - Pilot filter

OK or NG

- OK >> GO TO 4.
- NG >> Repair or replace damaged parts.

4. CHECK SYMPTOM

Check again.

OK or NG

- OK >> **INSPECTION END**
- NG >> GO TO 5.

TROUBLE DIAGNOSIS FOR SYMPTOMS

5. CHECK TCM INSPECTION

1. Perform TCM input/output signal inspection.
2. If NG, recheck TCM pin terminals for damage or loose connection with harness connector.

OK or NG

OK >> **INSPECTION END**

NG >> Repair or replace damaged parts.

TROUBLE DIAGNOSIS FOR SYMPTOMS

ECS006EJ

13. A/T Does Not Hold Lock-up Condition

SYMPTOM:

A/T does not hold lock-up condition for more than 30 seconds.

1. CHECK SELF-DIAGNOSTIC RESULTS

Does self-diagnosis show damage to engine speed signal circuit after cruise test?

Yes or No

- Yes >> Check engine speed signal circuit. Refer to [AT-120](#), "[DTC P0725 ENGINE SPEED SIGNAL](#)".
- No >> GO TO 2.

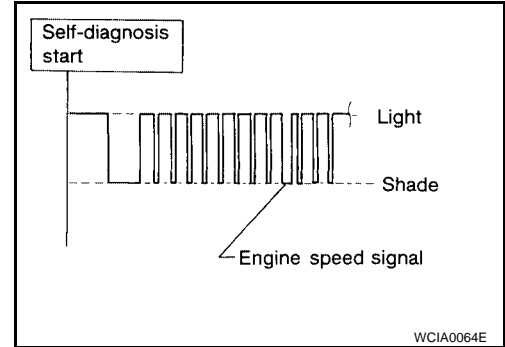

2. CHECK A/T FLUID CONDITION

1. Remove oil pan.
2. Check A/T fluid condition.

OK or NG

- OK >> GO TO 4.
- NG >> GO TO 3.

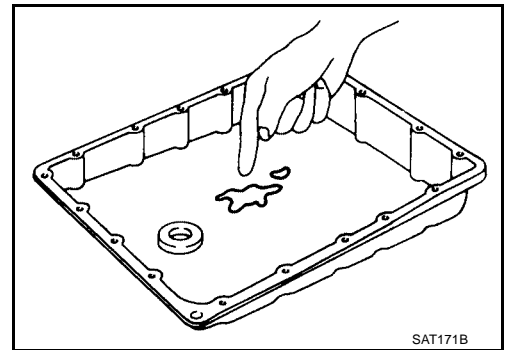

3. DETECT MALFUNCTIONING ITEM

1. Remove control valve assembly. Refer to [AT-264](#), "[Control Valve Assembly and Accumulators](#)".
2. Check the following items:
 - Torque converter clutch control valve
 - Pilot valve
 - Pilot filter
3. Disassemble A/T.
4. Check torque converter and oil pump assembly.

OK or NG

- OK >> GO TO 5.
- NG >> Repair or replace damaged parts.

TROUBLE DIAGNOSIS FOR SYMPTOMS

4. DETECT MALFUNCTIONING ITEM

1. Remove control valve assembly. Refer to [AT-264, "Control Valve Assembly and Accumulators"](#) .
2. Check the following items:
 - Torque converter clutch control valve
 - Pilot valve
 - Pilot filter

OK or NG

- OK >> GO TO 5.
NG >> Repair or replace damaged parts.

5. CHECK SYMPTOM

Check again.

OK or NG

- OK >> **INSPECTION END**
NG >> GO TO 6.

6. CHECK TCM INSPECTION

1. Perform TCM input/output signal inspection.
2. If NG, recheck TCM pin terminals for damage or loose connection with harness connector.

OK or NG

- OK >> **INSPECTION END**
NG >> Repair or replace damaged parts.

TROUBLE DIAGNOSIS FOR SYMPTOMS

ECS006EK

14. Lock-up Is Not Released

SYMPTOM:

Lock-up is not released when accelerator pedal is released.

1. CHECK THROTTLE POSITION SENSOR [ACCELERATOR PEDAL POSITION (APP) SENSOR] CIRCUIT

With CONSULT-II

Does "TCM INPUT SIGNALS" in "DATA MONITOR" show damage to throttle position sensor [accelerator pedal position (APP) sensor] circuit?

Without CONSULT-II

Does self-diagnosis show damage to throttle position sensor [accelerator pedal position (APP) sensor] circuit?

Yes or No

- Yes >> Check throttle position sensor [accelerator pedal position (APP) sensor]. Refer to [EC-178, "DTC P0122, P0123 TP SENSOR"](#) and [EC-534, "DTC P2122, P2123 APP SENSOR"](#) (with QR25DE), or [EC-822, "DTC P0122, P0123 TP SENSOR"](#) and [EC-1209, "DTC P2122, P2123 APP SENSOR"](#) (with VQ35DE).
- No >> GO TO 2.

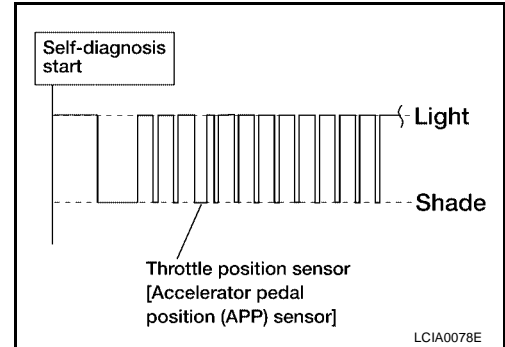

2. CHECK SYMPTOM

Check again.

OK or NG

- OK >> **INSPECTION END**
- NG >> GO TO 3.

3. CHECK TCM INSPECTION

1. Perform TCM input/output signal inspection.
2. If NG, recheck TCM pin terminals for damage or loose connection with harness connector.

OK or NG

- OK >> **INSPECTION END**
- NG >> Repair or replace damaged parts.

TROUBLE DIAGNOSIS FOR SYMPTOMS

ECS006EL

15. Engine Speed Does Not Return To Idle (Light Braking D4 → D3)

SYMPTOM:

- Engine speed does not smoothly return to idle when A/T shifts from D4 to D3 .
- Vehicle does not decelerate by engine brake when A/T selector lever is in 3 position.
- Vehicle does not decelerate by engine brake when shifting A/T from D to 2 position.

1. CHECK SELF-DIAGNOSTIC RESULTS

Does self-diagnosis show damage to overrun clutch solenoid valve circuit after cruise test?

Yes or No

- Yes >> Check overrun clutch solenoid valve circuit. Refer to [AT-181, "DTC P1760 OVERRUN CLUTCH SOLENOID VALVE"](#).
- No >> GO TO 2.

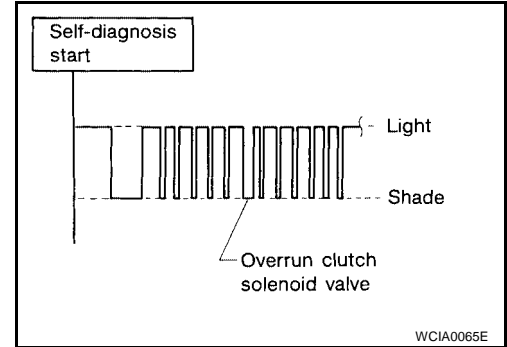

2. CHECK THROTTLE POSITION SENSOR [ACCELERATOR PEDAL POSITION (APP) SENSOR]

Check throttle position sensor [accelerator pedal position (APP) sensor]. Refer to [EC-178, "DTC P0122, P0123 TP SENSOR"](#) and [EC-534, "DTC P2122, P2123 APP SENSOR"](#) (with QR25DE), or [EC-822, "DTC P0122, P0123 TP SENSOR"](#) and [EC-1209, "DTC P2122, P2123 APP SENSOR"](#) (with VQ35DE).

OK or NG

- OK >> GO TO 3.
- NG >> Repair or replace throttle position sensor [accelerator pedal position (APP) sensor].

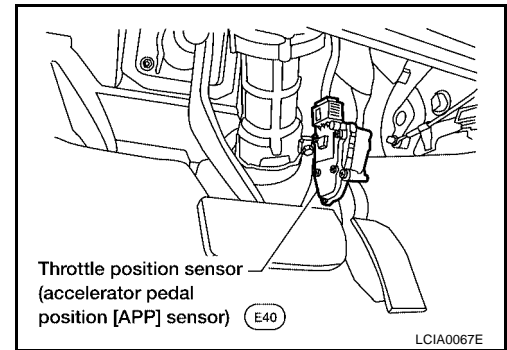

3. CHECK A/T FLUID CONDITION

1. Remove oil pan.
2. Check A/T fluid condition.

OK or NG

- OK >> GO TO 5.
- NG >> GO TO 4.

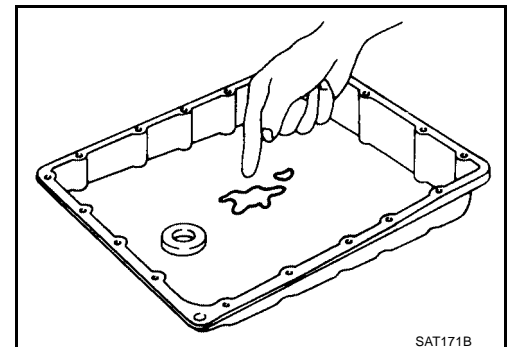

TROUBLE DIAGNOSIS FOR SYMPTOMS

4. DETECT MALFUNCTIONING ITEM

- 1. Remove control valve assembly. Refer to [AT-264, "Control Valve Assembly and Accumulators"](#) .
- 2. Check the following items:
 - Overrun clutch control valve
 - Overrun clutch reducing valve
 - Overrun clutch solenoid valve
- 3. Disassemble A/T.
- 4. Check the following items:
 - Overrun clutch assembly
 - Oil pump assembly

OK or NG

- OK >> GO TO 6.
- NG >> Repair or replace damaged parts.

5. DETECT MALFUNCTIONING ITEM

- 1. Remove control valve assembly. Refer to [AT-264, "Control Valve Assembly and Accumulators"](#) .
- 2. Check the following items:
 - Overrun clutch control valve
 - Overrun clutch reducing valve
 - Overrun clutch solenoid valve

OK or NG

- OK >> GO TO 6.
- NG >> Repair or replace damaged parts.

6. CHECK SYMPTOM

Check again.

OK or NG

- OK >> **INSPECTION END**
- NG >> GO TO 7.

7. CHECK TCM INSPECTION

- 1. Perform TCM input/output signal inspection.
- 2. If NG, recheck TCM pin terminals for damage or loose connection with harness connector.

OK or NG

- OK >> **INSPECTION END**
- NG >> Repair or replace damaged parts.

A

B

AT

D

E

F

G

H

I

J

K

L

M

TROUBLE DIAGNOSIS FOR SYMPTOMS

ECS006EM

16. Vehicle Does Not Start From D1

SYMPTOM:

Vehicle does not start from D1 on Cruise test — Part 2.

1. CHECK SELF-DIAGNOSTIC RESULTS

Does self-diagnosis show damage to vehicle speed sensor-A/T (revolution sensor), shift solenoid valve A, B or vehicle speed sensor-MTR after cruise test?

Yes or No

- Yes >> Check damaged circuit. Refer to [AT-115, "DTC P0720 VEHICLE SPEED SENSOR-A/T \(REVOLUTION SENSOR\)"](#), [AT-165, "DTC P0750 SHIFT SOLENOID VALVE A"](#), [AT-170, "DTC P0755 SHIFT SOLENOID VALVE B"](#) or [AT-196, "DTC VEHICLE SPEED SENSOR MTR"](#).
- No >> GO TO 2.

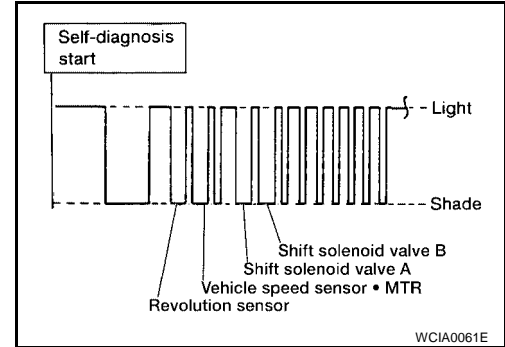

2. CHECK SYMPTOM

Check again.

OK or NG

- OK >> Go to [AT-227, "8. Vehicle Cannot Be Started From D1"](#).
- NG >> GO TO 3.

3. CHECK TCM INSPECTION

1. Perform TCM input/output signal inspection.
2. If NG, recheck TCM pin terminals for damage or loose connection with harness connector.

OK or NG

- OK >> **INSPECTION END**
- NG >> Repair or replace damaged parts.

TROUBLE DIAGNOSIS FOR SYMPTOMS

17. A/T Does Not Shift: D4 → 3₃ , When A/T Selector Lever D → 3

ECS006EN

SYMPTOM:

A/T does not shift from D₄ to 3₃ when changing A/T selector lever from D → 3 position.

1. CHECK 3 POSITION SWITCH CIRCUIT

With CONSULT-II

Does "TCM INPUT SIGNALS" in "DATA MONITOR" show damage to 3 position switch circuit?

Without CONSULT-II

Does self-diagnosis show damage to 3 position switch circuit?

Yes or No

- Yes >> Check 3 position switch circuit. Refer to [AT-103, "DTC P0705 PARK/NEUTRAL POSITION SWITCH"](#) .
- No >> Go to [AT-233, "10. A/T Does Not Shift: D₂ → D₃"](#) .

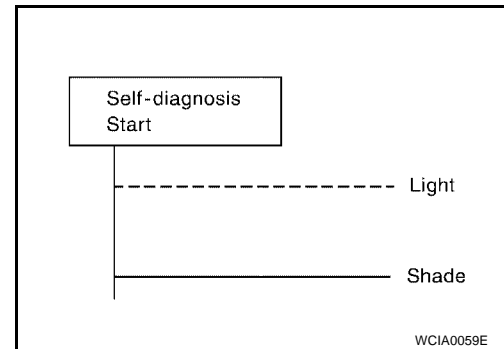

TROUBLE DIAGNOSIS FOR SYMPTOMS

18. A/T Does Not Shift: 33 → 22 , When Selector Lever 3 → 2 Position

ECS006EO

SYMPTOM:

A/T does not shift from 33 to 22 when changing selector lever from 3 to 2 position.

1. CHECK PARK/NEUTRAL POSITION (PNP) SWITCH CIRCUIT

With CONSULT-II

Does "TCM INPUT SIGNALS" in "DATA MONITOR" show damage to park/neutral position (PNP) switch circuit?

Without CONSULT-II

Does self-diagnosis show damage to park/neutral position (PNP) switch circuit?

Yes or No

- Yes >> Check park/neutral position (PNP) switch circuit. Refer to [AT-103, "DTC P0705 PARK/NEUTRAL POSITION SWITCH"](#) .
- No >> Go to [AT-230, "9. A/T Does Not Shift: D1 → D2 or Does Not Kickdown: D4 → D2"](#) .

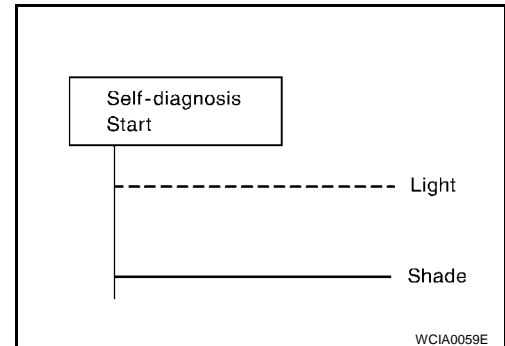

TROUBLE DIAGNOSIS FOR SYMPTOMS

19. A/T Does Not Shift: 22 → 11 , When Selector Lever 2 → 1 Position

ECS006EP

SYMPTOM:

A/T does not shift from 22 to 11 when changing selector lever from 2 to 1 position.

1. CHECK PARK/NEUTRAL POSITION (PNP) SWITCH CIRCUIT

With CONSULT-II

Does "TCM INPUT SIGNALS" in "DATA MONITOR" show damage to park/neutral position (PNP) switch circuit?

Without CONSULT-II

Does self-diagnosis show damage to park/neutral position (PNP) switch circuit?

Yes or No

- Yes >> Check park/neutral position (PNP) switch circuit. Refer to [AT-103, "DTC P0705 PARK/NEUTRAL POSITION SWITCH"](#).
- No >> GO TO 2.

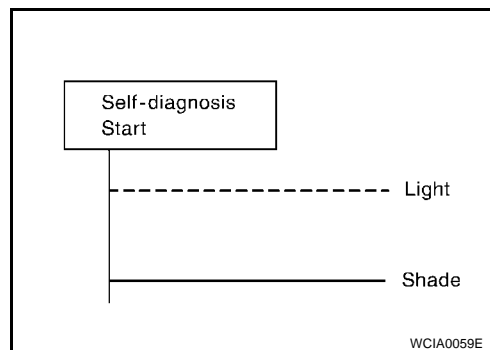

2. CHECK SYMPTOM

Check again.

OK or NG

- OK >> **INSPECTION END**
- NG >> GO TO 3.

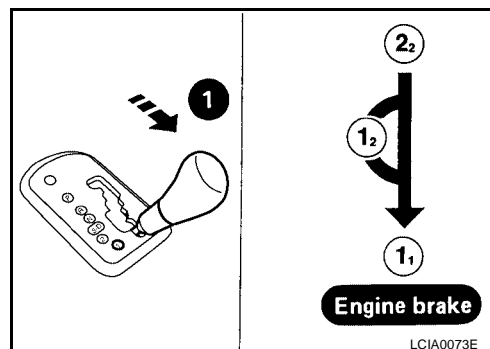

3. CHECK TCM INSPECTION

1. Perform TCM input/output signal inspection.
2. If NG, recheck TCM pin terminals for damage or loose connection with harness connector.

OK or NG

- OK >> **INSPECTION END**
- NG >> Repair or replace damaged parts.

TROUBLE DIAGNOSIS FOR SYMPTOMS

20. Vehicle Does Not Decelerate By Engine Brake

ECS006EQ

SYMPTOM:

Vehicle does not decelerate by engine brake when shifting from 22 (12) to 11.

1. CHECK SYMPTOM

Is "6. Vehicle Does Not Creep Backward In R Position" OK?

Yes or No

- Yes >> Go to [AT-244, "15. Engine Speed Does Not Return To Idle \(Light Braking D4 → D3\)"](#).
- No >> Go to [AT-221, "6. Vehicle Does Not Creep Backward In R Position"](#).

21. TCM Self-diagnosis Does Not Activate (PNP & 3 Position Switches Circuit Checks), and Throttle Position Sensor [Accelerator Pedal Position (APP) Sensor] Circuit Check

ECS006ER

SYMPTOM:

A/T check (position) indicator lamp does not come on in TCM self-diagnostic procedure even if the lamp circuit is good.

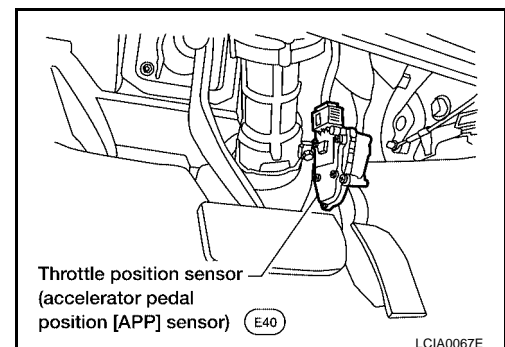
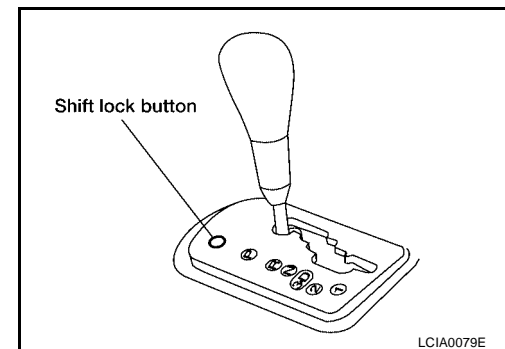
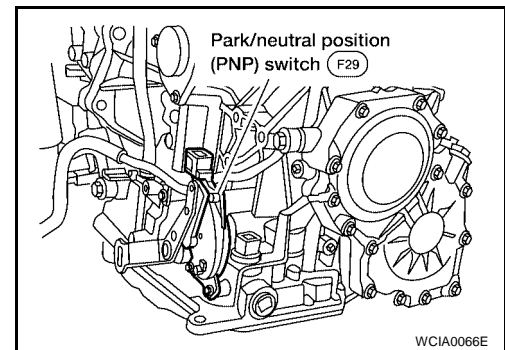

DESCRIPTION

- Park/neutral position (PNP) switch
The park/neutral (PNP) switch assembly includes a transmission range switch. The transmission range switch detects the selector lever position and sends a signal to the TCM.
- 3 position switch

TROUBLE DIAGNOSIS FOR SYMPTOMS

Detects the A/T selector lever in 3 position and sends a signal to the TCM.

- Throttle position sensor [accelerator pedal position (APP) sensor]
The throttle position sensor [accelerator pedal position (APP) sensor] is part of the system that controls the throttle position. This system also uses an electric throttle control actuator, which consists of a throttle control motor and throttle position sensors. Accelerator pedal position signal is sent to the ECM.

A
B

AT

D

E

F

G

H

I

J

K

L

M

TROUBLE DIAGNOSIS FOR SYMPTOMS

DIAGNOSTIC PROCEDURE

NOTE:

The diagnostic procedure includes inspection for the 3 position switch circuit.

1. CHECK PARK/NEUTRAL POSITION (PNP) SWITCH CIRCUIT (WITH CONSULT-II)

With CONSULT-II

- Turn ignition switch to "ON" position.
(Do not start engine.)
- Select "TCM INPUT SIGNALS" in "DATA MONITOR" mode for "A/T" with CONSULT-II.
- Read out P/N, R, D, 2 and 1 position switches moving selector lever to each position.
Check that the signal of the selector lever position is indicated properly.

OK or NG

- OK >> GO TO 5.
NG >> GO TO 2.

DATA MONITOR	
MONITORING	
PN POSI SW	OFF
R POSITION SW	OFF
D POSITION SW	OFF
2 POSITION SW	ON
1 POSITION SW	OFF

SAT701J

2. DETECT MALFUNCTIONING ITEM

Check the following items:

- Park/neutral position (PNP) switch
 - Check continuity between park/neutral position (PNP) switch F29 terminals 1 (G/R) and 2 (B) and between terminals 3 (G/Y) and 4 (PU/W), 5 (P/B), 6 (G), 7 (BR), 8 (G/W) and 9 (GY/R) while moving manual shaft through each position.

Lever position	Terminal No.	
P	3 - 7	1 - 2
R	3 - 8	
N	3 - 9	1 - 2
D	3 - 6	
2	3 - 5	
1	3 - 4	

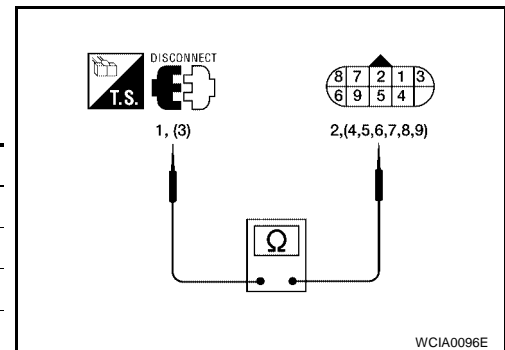

- If NG, check again with manual control cable disconnected from manual shaft of A/T assembly. Refer to step a.
- If OK on step b, adjust manual control cable. Refer to [AT-267, "Control Cable Adjustment"](#).
- If NG on step b, remove park/neutral position (PNP) switch from A/T and check continuity of park/neutral position (PNP) switch terminals. Refer to step a.
- If OK on step d, adjust park/neutral position (PNP) switch. Refer to [AT-266, "Park/Neutral Position \(PNP\) Switch Adjustment"](#).
- If NG on step d, replace park/neutral position (PNP) switch.
- Harness for short or open between ignition switch and park/neutral position (PNP) switch (Main harness)
- Harness for short or open between park/neutral position (PNP) switch and TCM (Main harness)

OK or NG

- OK >> GO TO 5.
NG >> Repair or replace damaged parts.

TROUBLE DIAGNOSIS FOR SYMPTOMS

3. CHECK PARK/NEUTRAL POSITION (PNP) SWITCH CIRCUIT (WITHOUT CONSULT-II)

⊗ **Without CONSULT-II**

1. Turn ignition switch to ON position. (Do not start engine.)
2. Check voltage between TCM terminals 26 (PU/W), 27 (P/B), 34 (G), 35 (G/W), 36 (R/B) and ground while moving selector lever through each position.

Lever Position	Terminal No.				
	36	35	34	27	26
P, N	B	0	0	0	0
R	0	B	0	0	0
D	0	0	B	0	0
2	0	0	0	B	0
1	0	0	0	0	B

**Volt-
age:**

B : Battery voltage

0 : 0V

OK or NG

OK >> GO TO 6.

NG >> GO TO 4.

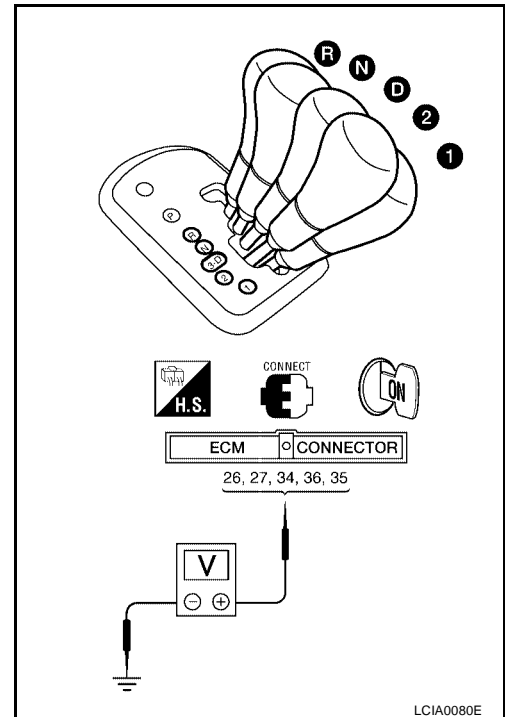

A
B
AT
D
E
F
G
H
I
J
K
L
M

TROUBLE DIAGNOSIS FOR SYMPTOMS

4. DETECT MALFUNCTIONING ITEM

Check the following items:

- Park/neutral position (PNP) switch
 - Check continuity between park/neutral position (PNP) switch terminals 1 (G/R) and 2 (B), and between terminals 3 (G/Y) and 4 (PU/W), 5 (P/B), 6 (G), 7 (BR), 8 (G/W) and 9 (GY/R) while moving manual shaft through each position.

Lever position	Terminal No.	
P	3 - 7	1 - 2
R	3 - 8	
N	3 - 9	1 - 2
D	3 - 6	
2	3 - 5	
1	3 - 4	

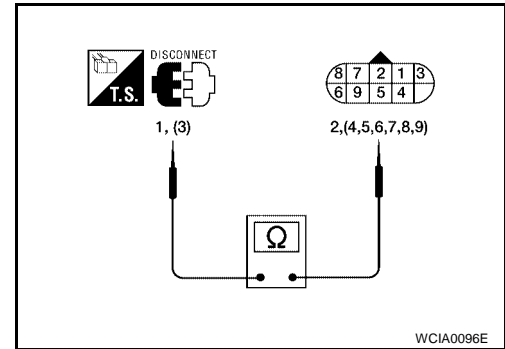

- If NG, check again with manual control cable disconnected from manual shaft of A/T assembly. Refer to step a.
- If OK on step b, adjust manual control cable. Refer to [AT-267, "Control Cable Adjustment"](#).
- If NG on step b, remove park/neutral position (PNP) switch from A/T and check continuity of park/neutral position (PNP) switch terminals. Refer to step a.
- If OK on step d, adjust park/neutral position (PNP) switch. Refer to [AT-266, "Park/Neutral Position \(PNP\) Switch Adjustment"](#).
- If NG on step d, replace park/neutral position (PNP) switch.
- Harness for short or open between ignition switch and park/neutral position (PNP) switch (Main harness)
- Harness for short or open between park/neutral position (PNP) switch and TCM (Main harness)

OK or NG

- OK >> GO TO 7.
- NG >> Repair or replace damaged parts.

5. CHECK 3 POSITION SWITCH CIRCUIT (WITH CONSULT-II)

Ⓜ With CONSULT-II

1. Turn ignition switch to "ON" position.
(Do not start engine.)
2. Select "TCM INPUT SIGNALS" in "DATA MONITOR" mode for "A/T" with CONSULT-II.
3. Read out "OVERDRIVE SW".
Check the signal of the 3 position switch is indicated properly.
(Overdrive switch "ON" displayed on CONSULT-II means overdrive "OFF".)

OK or NG

- OK >> GO TO 7.
- NG >> GO TO 6.

DATA MONITOR	
MONITORING	
ENGINE SPEED	XXX rpm
TURBINE REV	XXX rpm
OVERDRIVE SW	ON
PN POSI SW	OFF
R POSITION SW	OFF

SAT645J

TROUBLE DIAGNOSIS FOR SYMPTOMS

6. DETECT MALFUNCTIONING ITEM

Check the following items:

- 3 position switch M34.
 - Check for continuity between terminals 1 (L/W) and 2 (B) with selector lever in 3 position.
- Harness for short or open between meter and 3 position switch (Main harness)
- Harness of ground circuit for 3 position switch (Main harness) for short or open

OK or NG

OK >> GO TO 7.

NG >> Repair or replace damaged parts.

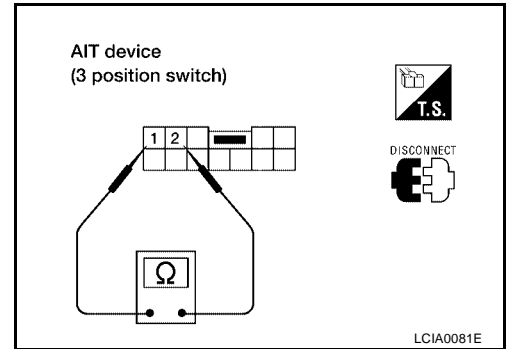

7. CHECK THROTTLE POSITION SENSOR [ACCELERATOR PEDAL POSITION (APP) SENSOR]

- Perform throttle position sensor [accelerator pedal position (APP) sensor] inspection. Refer to [AT-175, "DTC P1705 THROTTLE POSITION SENSOR \[ACCELERATOR PEDAL POSITION \(APP\) SENSOR\]"](#).

OK or NG

OK >> GO TO 8.

NG >> Repair or replace damaged parts.

8. CHECK TCM INSPECTION

1. Perform TCM input/output inspection. Refer to [AT-93, "TCM INSPECTION TABLE"](#)

OK or NG

OK >> **INSPECTION END**

NG >> Inspect TCM terminals and related wiring harnesses for damage or loose connections. Repair or replace damaged parts.

A/T SHIFT LOCK SYSTEM

A/T SHIFT LOCK SYSTEM

PFP:34950

Description

ECS006ES

- The mechanical key interlock mechanism also operates as a shift lock:
With the key switch turned to ON, the selector lever cannot be shifted from "P" (parking) to any other position unless the brake pedal is depressed.
With the key removed, the selector lever cannot be shifted from "P" to any other position.
The key cannot be removed unless the selector lever is placed in "P".
- The shift lock and key interlock mechanisms are controlled by the ON-OFF operation of the shift lock solenoid and by the operation of the rotator and slider located inside the key cylinder.

Shift Lock System Electrical Parts Location

ECS006ET

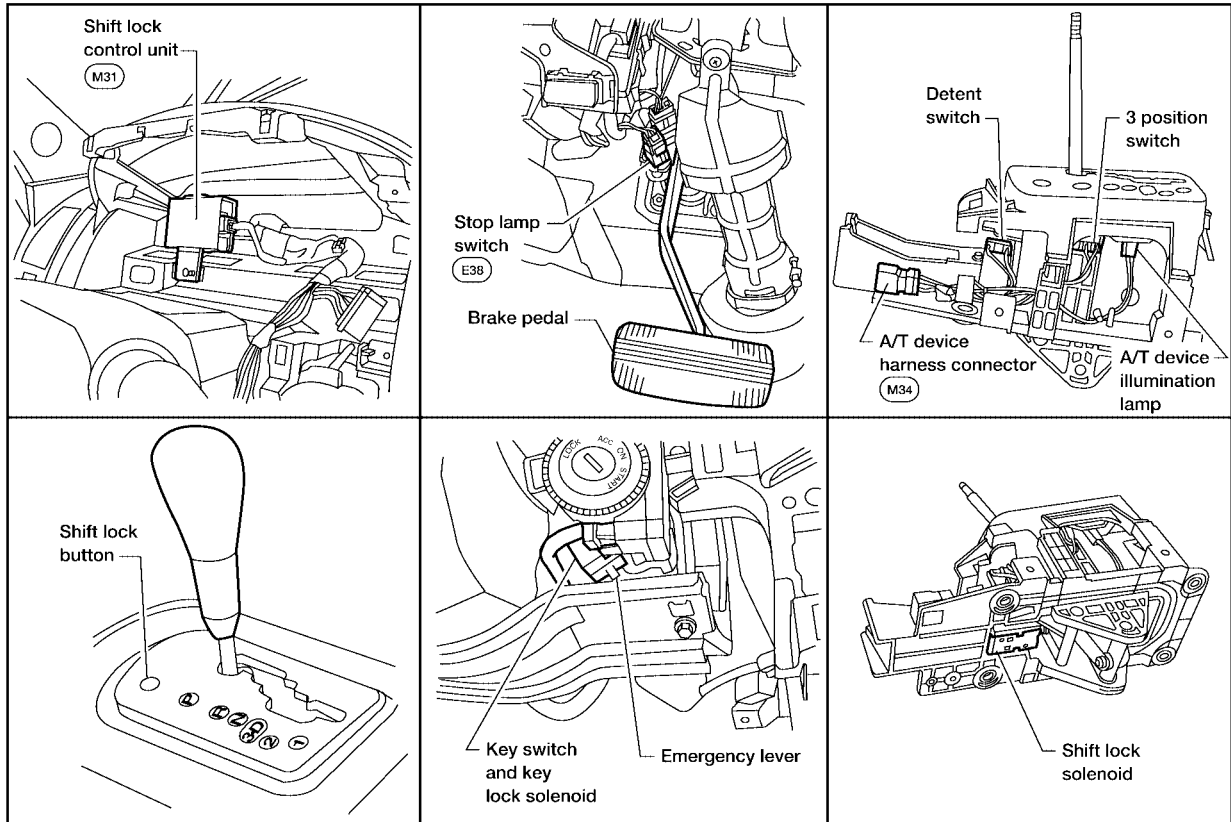

LCIA0082E

A/T SHIFT LOCK SYSTEM

Wiring Diagram — SHIFT —

ECS006EU

AT-SHIFT-01

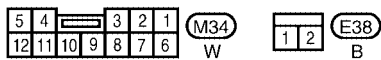
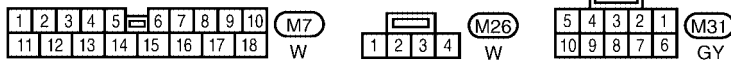
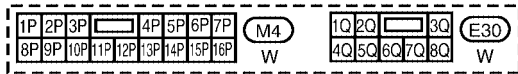
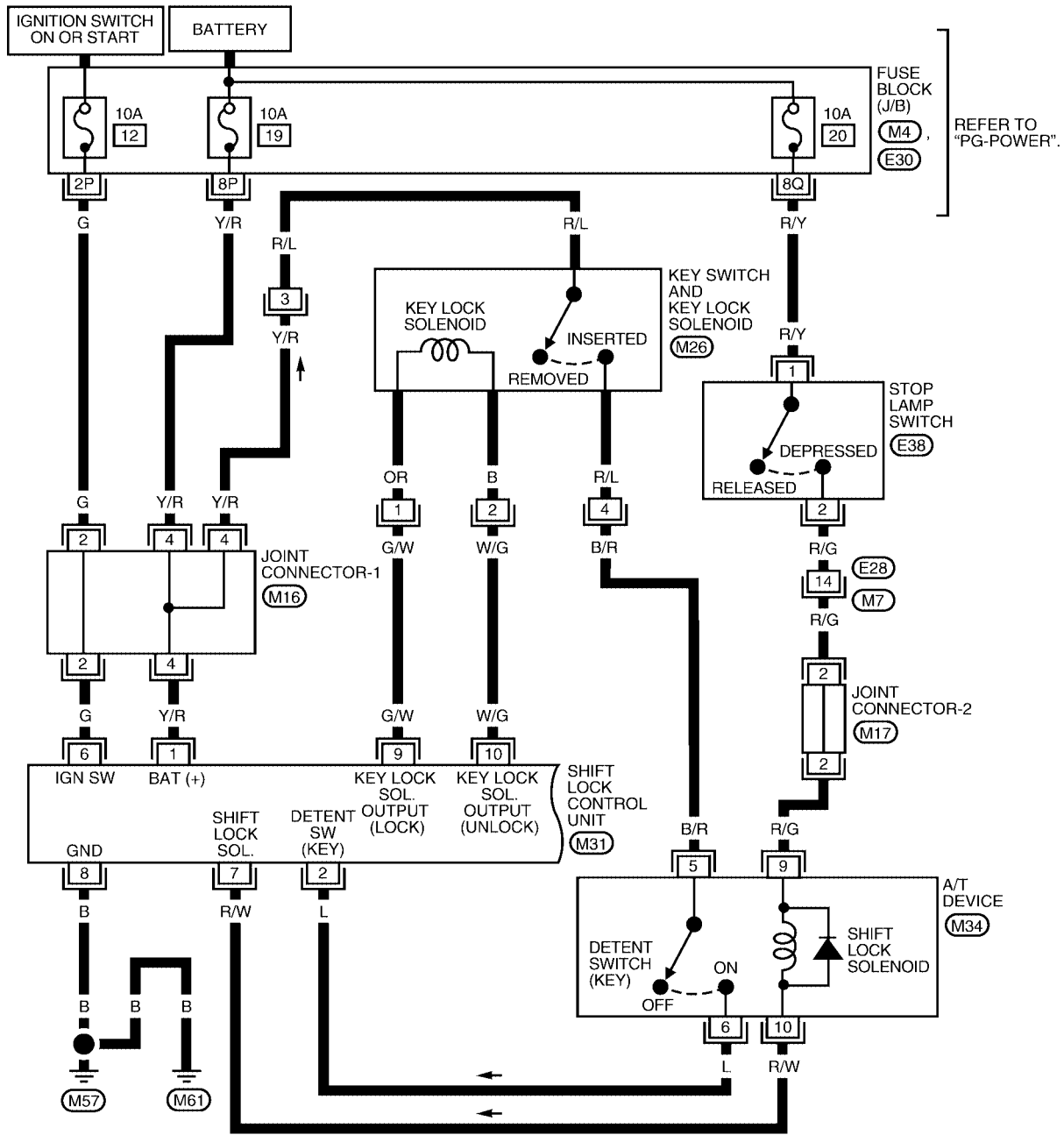

REFER TO THE FOLLOWING.

M16, M17 - JOINT CONNECTOR (J/C)

LCWA0027E

A/T SHIFT LOCK SYSTEM

AT-SHIFT-02

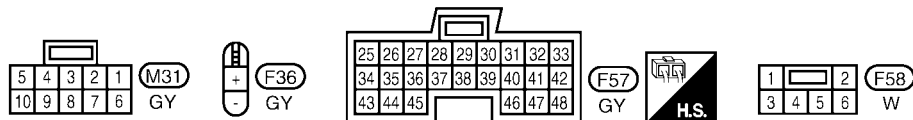
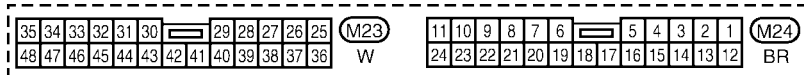
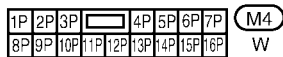
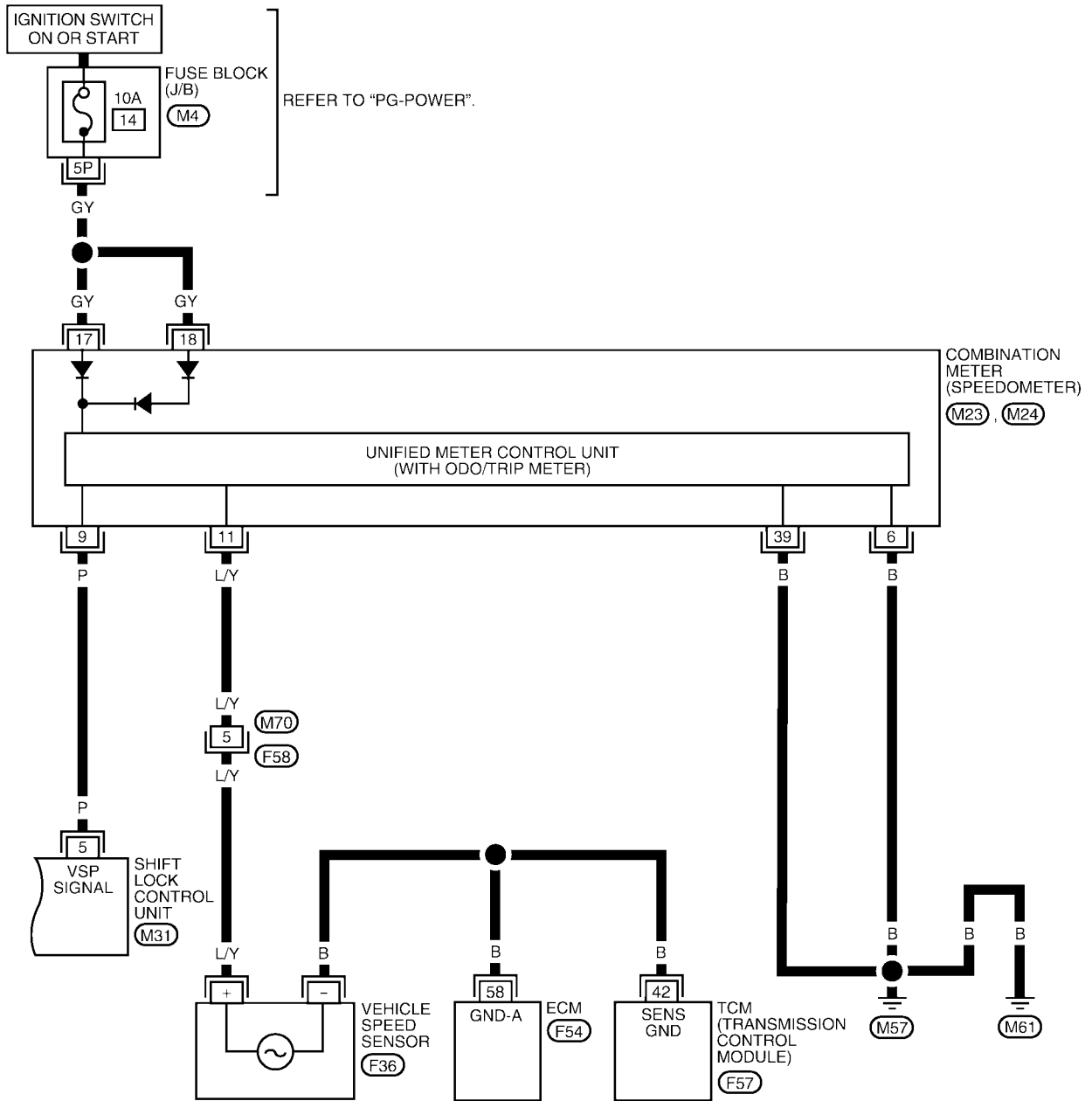

REFER TO THE FOLLOWING.
 (F51) - ELECTRICAL UNITS

WCWA0058E

A/T SHIFT LOCK SYSTEM

Shift Lock Control Unit Reference Values SHIFT LOCK HARNESS CONNECTOR TERMINAL LAYOUT

ECS006EV

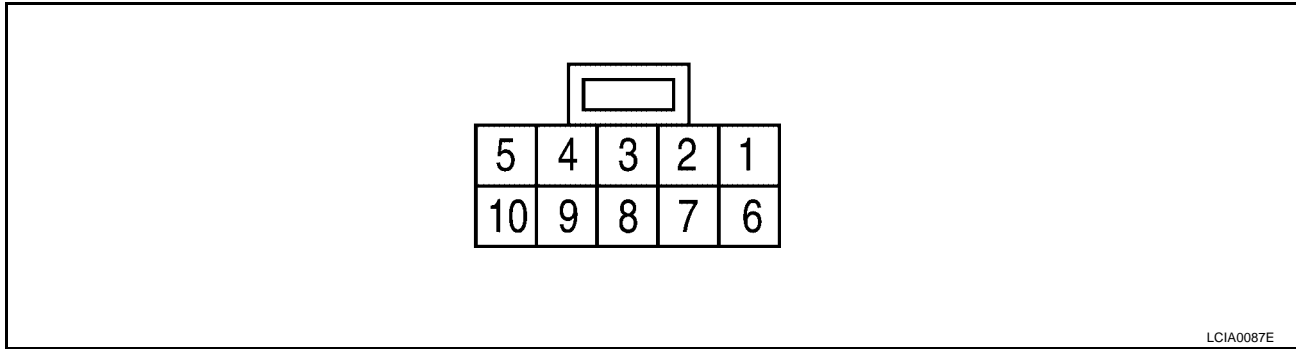

LCIA0087E

SHIFT LOCK CONTROL UNIT INSPECTION TABLE

Data are reference values.

Terminal No.		Item	Condition	Judgement standard
(+)	(-)			
1	8	Power source	IGN SW: "ON"	Battery voltage
			IGN SW: "OFF"	
2	8	Detent SW (key)	The position when the key is inserted and the selector lever is set to a position other than the "P" position	Battery voltage
			Except the above	Approx. 0V
6	8	IGN Signal	IGN SW: "ON"	Battery voltage
			IGN SW: "OFF"	Approx. 0V
7	8	Shift Lock Solenoid	When the brake pedal is depressed	Battery voltage
			IGN SW: "ON" and vehicle speed is less than 8 km/h (5 mph)	Approx. 0V
8	-	Ground	IGN SW: "ON"	Approx. 0V
9	8	Key Lock Signal	When the selector lever is set to a position other than the "P" position	-12V for approx. 30 ms
			Except the above	Approx. 0V
10	8	Key Unlock Signal	When the selector lever is set to the "P" position	Battery voltage for approx. 150 ms
			Except the above	Approx. 0V

CAUTION:

Confirm that the pointer swings only momentarily because the output time is so short. If the inspection is done with an oscilloscope, it should be observed that the power source voltage lasts for 3.5 to 10 ms.

Component Inspection SHIFT LOCK SOLENOID

ECS006EW

- Check operation by applying battery voltage to A/T device connector.

CAUTION:

Be sure to apply the voltage of the correct polarity to the respective terminals. Otherwise, the part may be damaged.

Connector No.	Terminal No.
M34	9 (Battery voltage) - 10 (Ground)

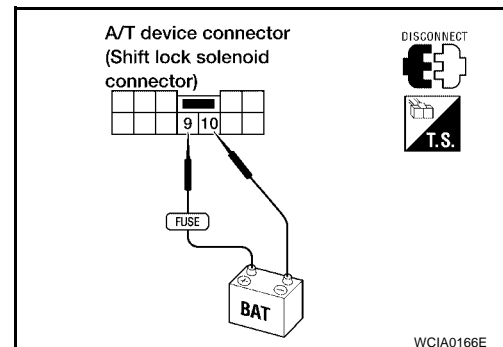

WCIA0166E

A/T SHIFT LOCK SYSTEM

DETENT SWITCH

For Key:

- Check continuity between terminals of the A/T device connector.

Condition	Connector No.	Terminal No.	Continuity
The position when the selector lever is set to a position other than the "P" position, or when it is shifted from the "R" to the "P" position	M34	5 - 6	Yes
Except the above			No

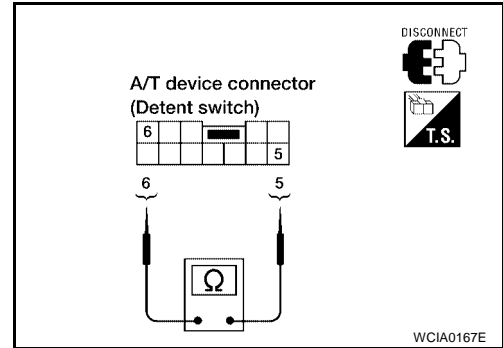

KEY LOCK SOLENOID

Key Lock

- Check operation by applying battery voltage to key switch and key lock solenoid connector.

CAUTION:

Be careful not to cause burnout of the harness.

Connector No.	Terminal No.
M26	1 (Battery voltage) - 2 (Ground)

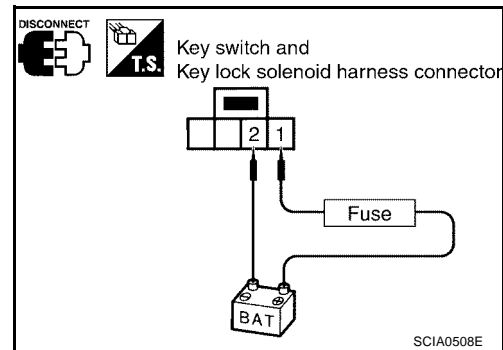

Key Unlock

- Check operation by applying battery voltage to key switch and key lock solenoid connector.

CAUTION:

Be careful not to cause burnout of the harness.

Connector No.	Terminal No.
M26	2 (Battery voltage) - 1 (Ground)

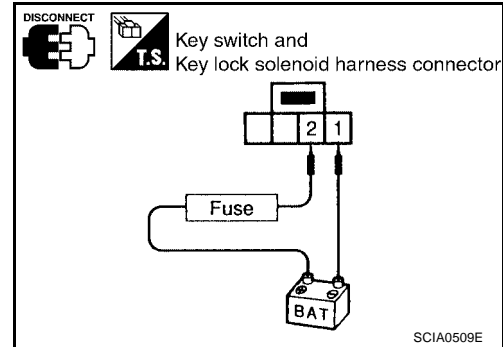

KEY SWITCH

- Check continuity between terminals of the key switch and key lock solenoid connector.

Condition	Connector No.	Terminal No.	Continuity
Key inserted	M26	3 - 4	Yes
Key removed			No

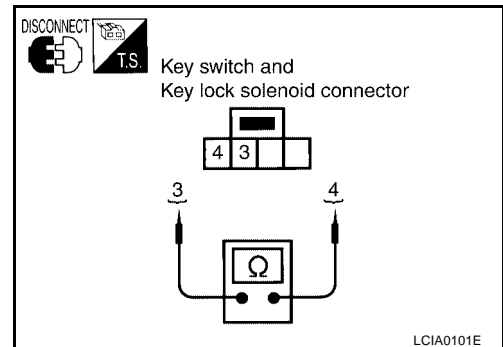

A/T SHIFT LOCK SYSTEM

STOP LAMP SWITCH

- Check continuity between terminals of the stop lamp switch connector.

Condition	Connector No.	Terminal No.	Continuity
When brake pedal is depressed	E38	1 - 2	Yes
When brake pedal is released			No

Check stop lamp switch after adjusting brake pedal. Refer to [BR-6](#), "[Inspection and Adjustment](#)".

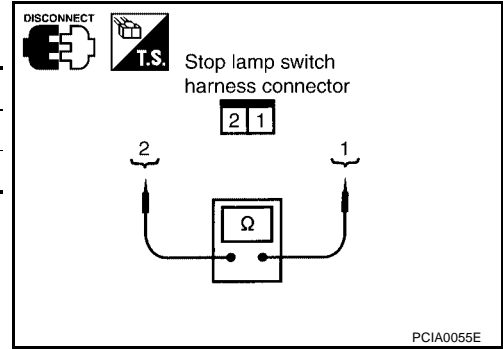

A
B
AT
D
E
F
G
H
I
J
K
L
M

SHIFT CONTROL SYSTEM

SHIFT CONTROL SYSTEM

PFP:34901

Control Device

ECS006EX

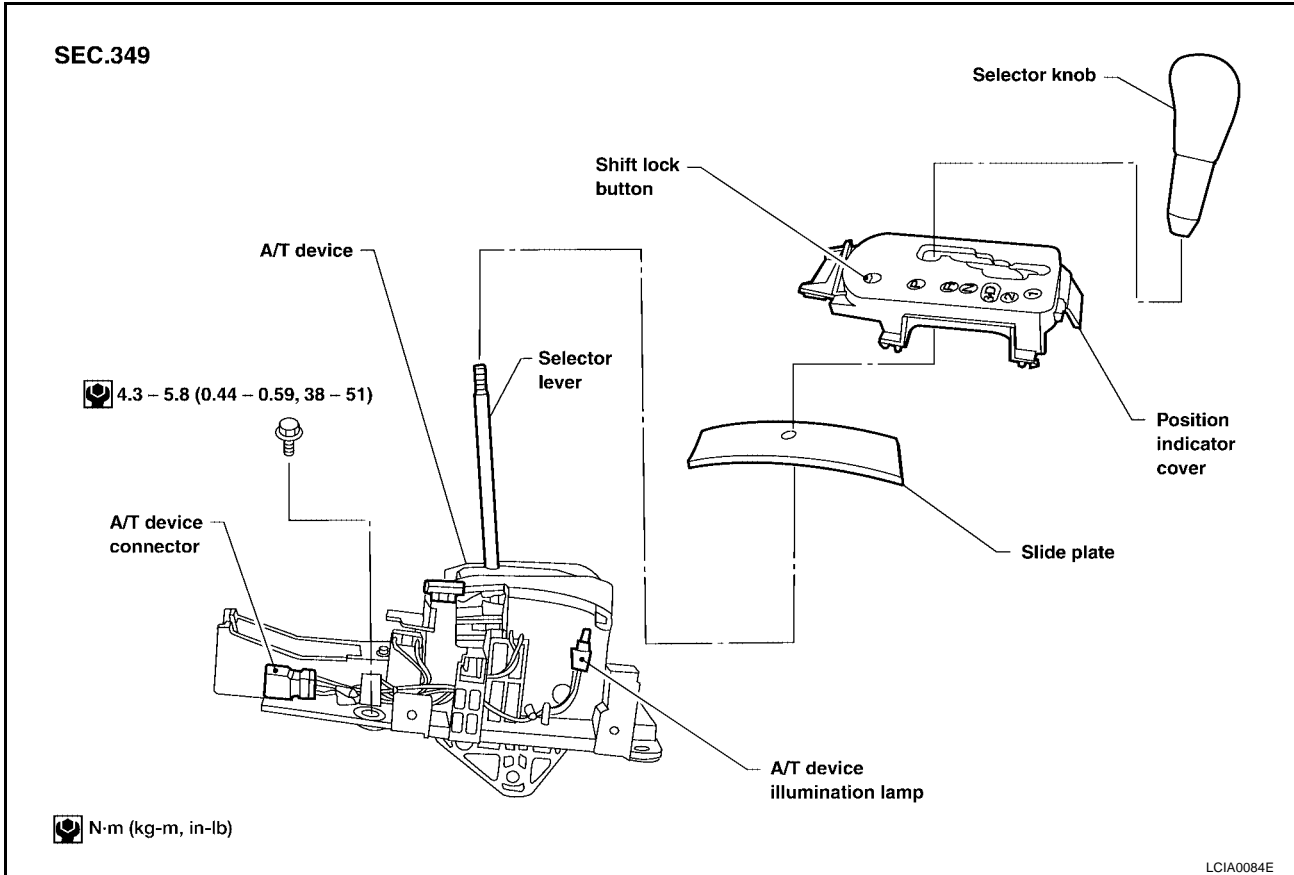

SHIFT CONTROL SYSTEM

Control Cable

ECS006EY

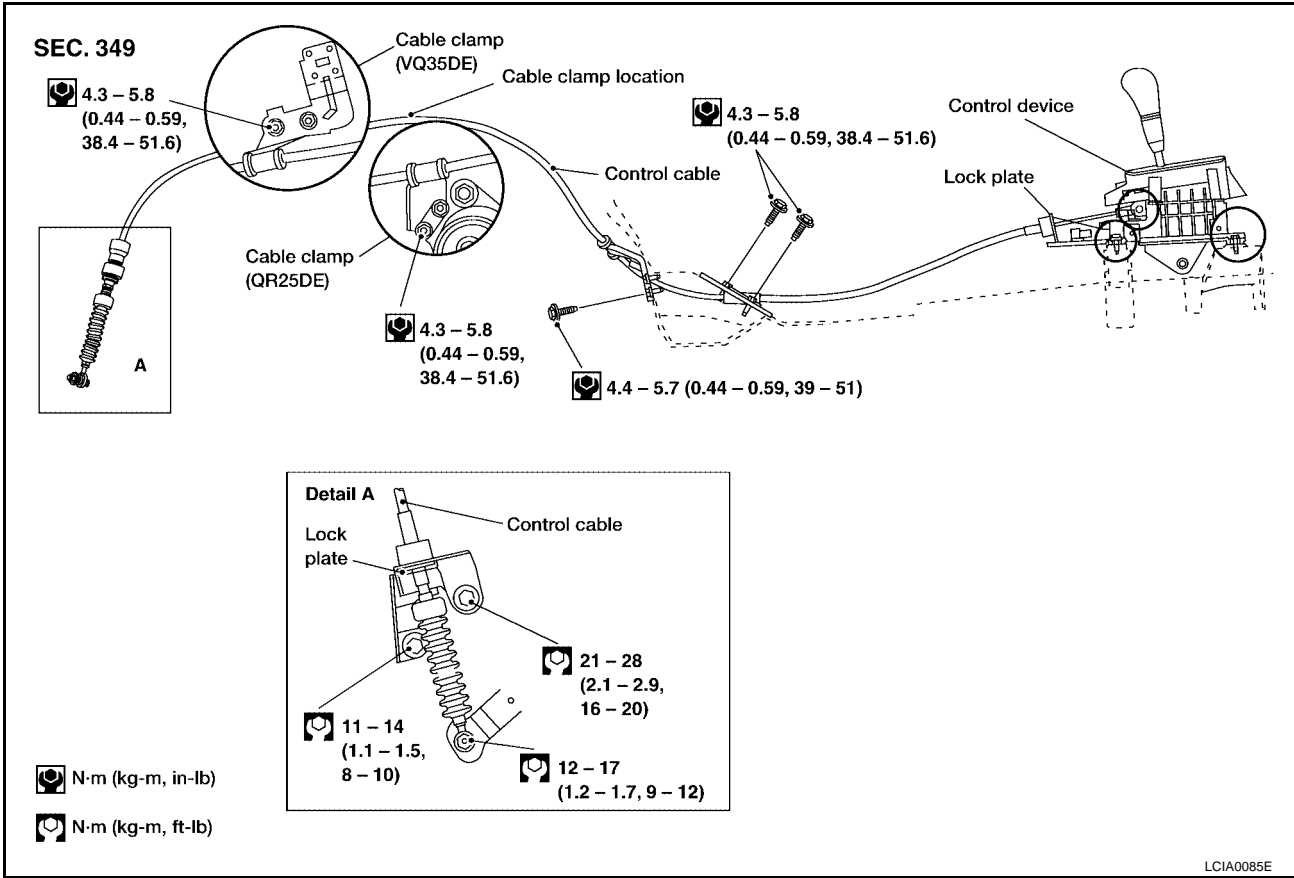

A
B
AT
D
E
F
G
H
I
J
K
L
M

ON-VEHICLE SERVICE

Control Valve Assembly and Accumulators REMOVAL

1. Drain ATF from transaxle.
 - Do not reuse oil pan bolts.

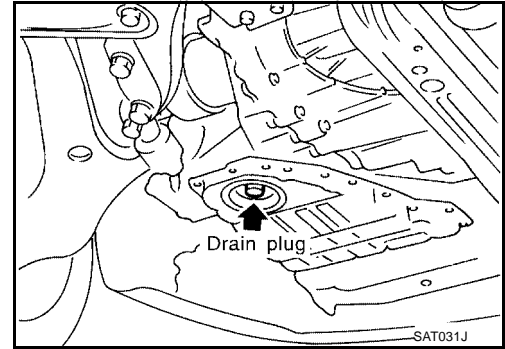

3. Disconnect terminal cord assembly harness connector.

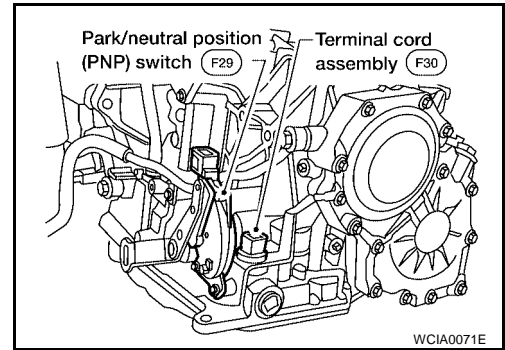

4. Remove stopper ring from terminal cord assembly harness terminal body.
5. Remove terminal cord assembly harness from transmission case by pushing on terminal body.

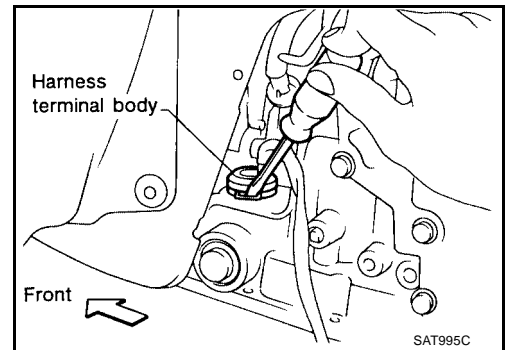

ON-VEHICLE SERVICE

6. Remove control valve assembly by removing fixing bolts I , X and ●.
- Bolt length, number and location are shown in the illustration.
- **Be careful not to drop manual valve and servo release accumulator return spring.**
7. Disassemble and inspect control valve assembly if necessary. Refer to [AT-299, "Control Valve Assembly"](#).

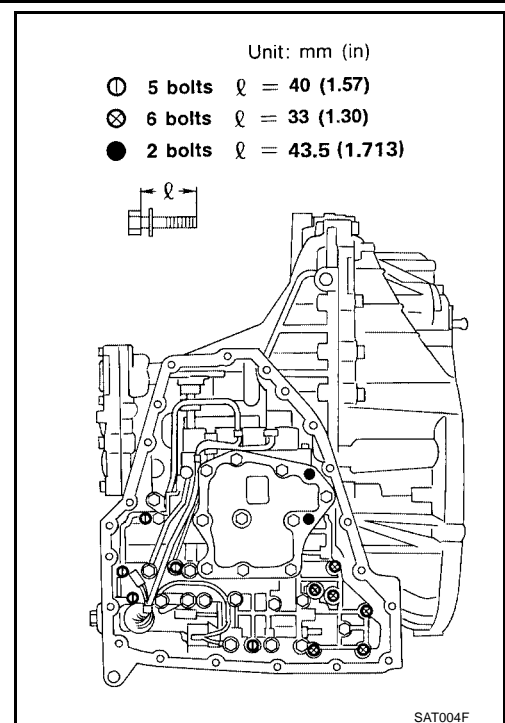

8. Remove servo release and N-D accumulators by applying compressed air if necessary.
- **Hold each piston with a rag.**

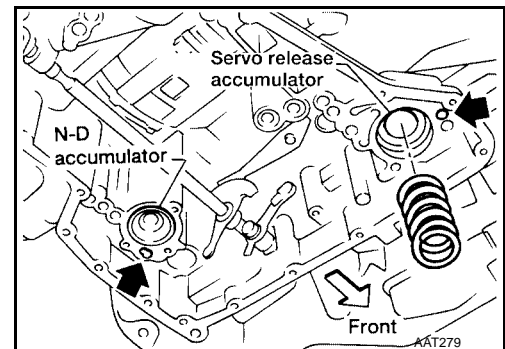

INSTALLATION

- **Set manual shaft in Neutral, then align manual plate with groove in manual valve.**
- **After installing control valve assembly, make sure that selector lever can be moved to all positions.**

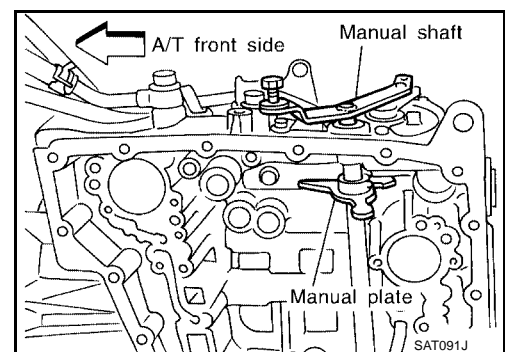

Revolution Sensor Replacement

ECS006F0

1. Disconnect electrical connector.
2. Remove revolution sensor from A/T.
3. Reinstall any part removed.
 - **Always use new sealing parts.**

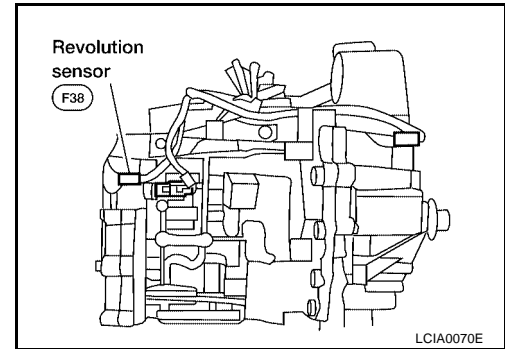

Turbine Revolution Sensor Replacement

ECS006F1

1. Disconnect electrical connector.
2. Remove bolt, and turbine revolution sensor from A/T.
3. Reinstall any part removed.
 - **Always use new sealing parts.**

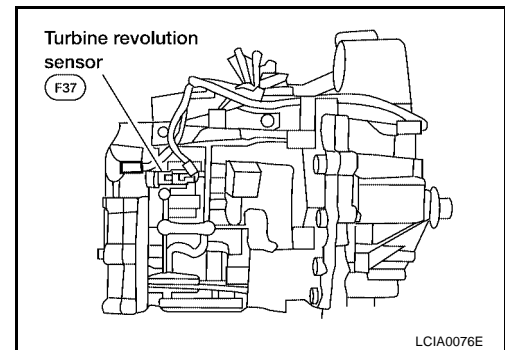

Park/Neutral Position (PNP) Switch Adjustment

ECS006F2

1. Remove control cable from manual shaft.
2. Set manual shaft in N position.
3. Loosen park/neutral position (PNP) switch fixing bolts.

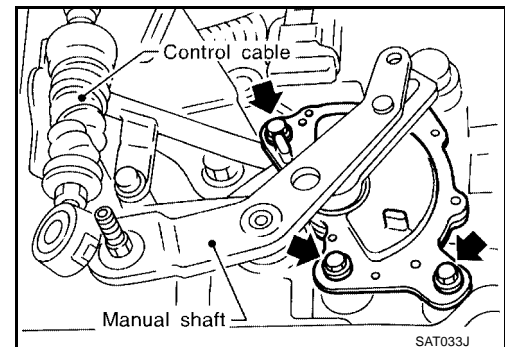

4. Insert pin into adjustment holes in both park/neutral position (PNP) switch and manual shaft as near vertical as possible.
5. Reinstall any part removed.
6. Check continuity of park/neutral position (PNP) switch. Refer to [AT-106, "Diagnostic Procedure"](#).

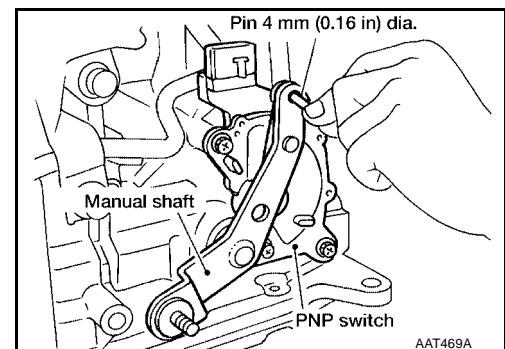

Control Cable Adjustment

ECS006F3

Move selector lever from the P position to the 1 position. You should be able to feel the detent in each position. If the detent cannot be felt or the pointer indicating the position is improperly aligned, the control cable needs adjustment.

1. Place selector lever in the P position.

CAUTION:

Turn wheels more than 1/4 turn and apply the parking brake.

2. Loosen control cable lock nut.
3. Secure the manual lever.
4. Using the specified force, push control cable in the direction of the arrow shown in the illustration.

Specified force : 9.8 N (1.0 kg, 2.2 lb)

5. Tighten control cable lock nut.
6. Move selector lever from P to 1 position. Make sure that selector lever moves smoothly.
 - Make sure that the starter operates when the selector lever is placed in the N or P position.
 - Make sure that the transmission is locked properly when the selector lever is placed in the P position.

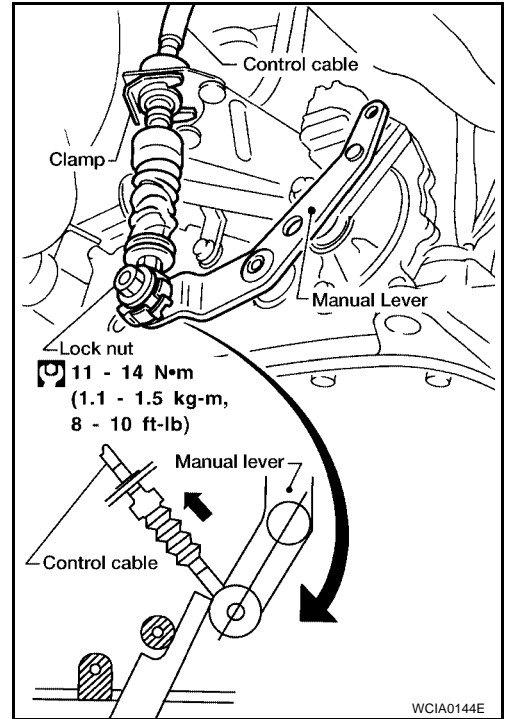

WCIA0144E

Differential Side Oil Seal Replacement

ECS006F4

1. Remove drive shaft assembly. Refer to [FAX-11, "FRONT DRIVE SHAFT"](#).
2. Remove oil seal.

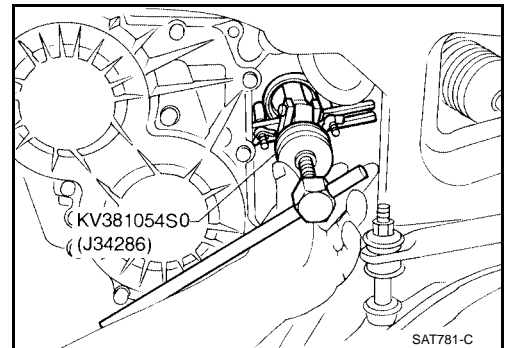

3. Install oil seal.
 - Apply ATF before installing.

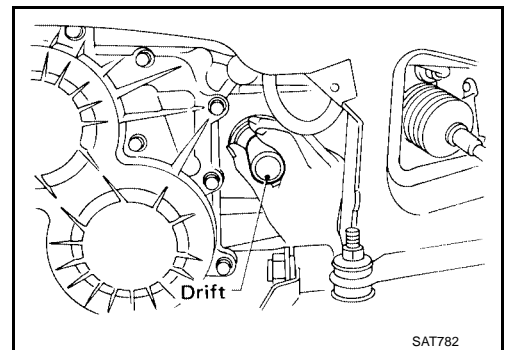

A
B
AT
D
E
F
G
H
I
J
K
L
M

ON-VEHICLE SERVICE

- Install oil seals so dimension A is within specification

A : -0.5 mm (-0.02 in) to 0.5 mm (0.02 in)

4. Reinstall any part removed.

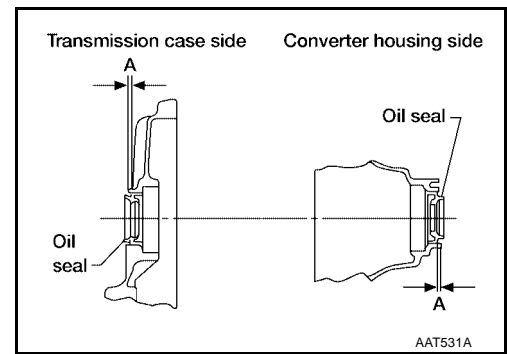

REMOVAL AND INSTALLATION

PF0:0000

ECS006F5

REMOVAL AND INSTALLATION

Removal

CAUTION:

When removing the transaxle assembly from engine, first remove the crankshaft position sensor from the assembly (with VQ35DE).

Be careful not to damage sensor edge.

1. Remove battery and bracket.
2. Remove air cleaner assembly, refer to [EM-16, "Removal and Installation"](#) (with QR25DE), or [EC-983, "CONSULT-II Reference Value in Data Monitor Mode"](#) (with VQ35DE).
3. Disconnect terminal cord assembly harness connector and park/neutral position (PNP) switch harness connectors.
4. Disconnect harness connectors of revolution sensor, ground, vehicle speed sensor, mass air flow sensor, and turbine revolution sensor.
5. Remove crankshaft position sensor from transaxle (with VQ35DE).
6. Remove LH mounting bracket from transaxle and body.
7. Disconnect control cable at transaxle side.
8. Remove drive shafts. Refer to [FAX-11, "FRONT DRIVE SHAFT"](#).
9. Drain ATF.
10. Remove push clips and engine undercover.
11. Disconnect fluid cooler piping.
12. Remove starter motor from transaxle refer to [SC-23, "Removal and Installation"](#).

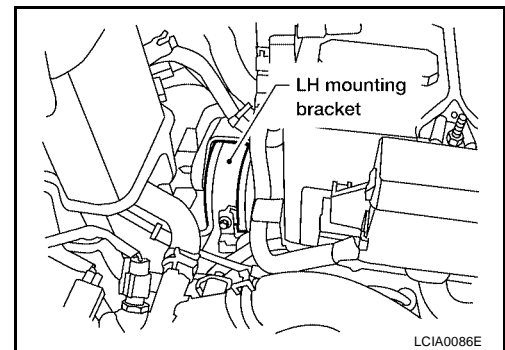

13. Support engine.
14. Remove upper transaxle to engine bolts.
15. Remove front suspension member, refer to [FSU-14, "Removal and Installation"](#).
16. Remove rear cover plate and bolts securing torque converter to drive plate.
 - **Rotate crankshaft for access to securing bolts.**

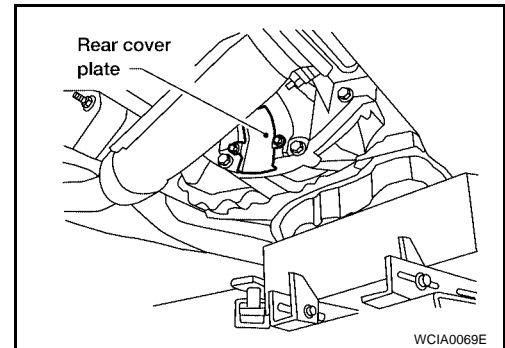

17. Support transaxle with a jack.
18. Remove lower transaxle to engine bolts.
19. Lower transaxle while supporting it with a jack.

REMOVAL AND INSTALLATION

ECS006F6

Installation

- Drive plate runout

CAUTION:

Do not allow any magnetic materials to contact the ring gear teeth.

Maximum allowable runout:

Refer to [EM-100, "SERVICE DATA AND SPECIFICATIONS \(SDS\)"](#) (with QR25DE).

Refer to [EM-227, "SERVICE DATA AND SPECIFICATIONS \(SDS\)"](#) (with VQ35DE).

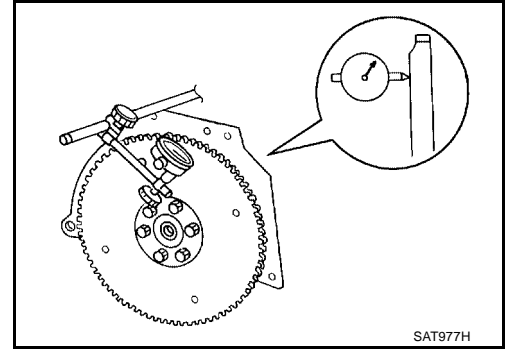

SAT977H

- If this runout is out of allowance, replace drive plate and ring gear.
- When connecting torque converter to transaxle, measure distance "A" to be certain that they are correctly assembled.

Distance "A" : 14 mm (0.55 in) or more

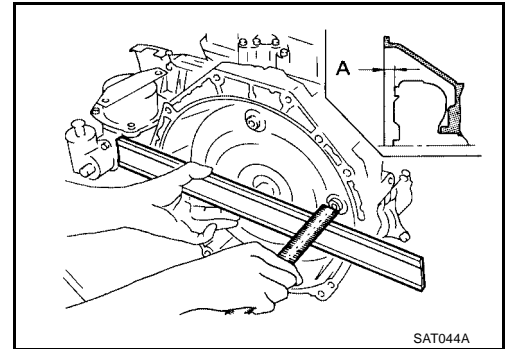

SAT044A

- Install bolts fixing converter to drive plate.
- **With converter installed, rotate crankshaft several turns to check that transaxle rotates freely without binding.**

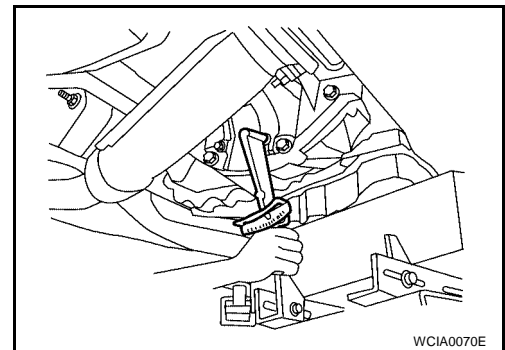

WCIA0070E

- Tighten bolts securing transaxle.
- Tighten LH mounting bracket bolts to the specified torque. Refer to [EM-72, "Removal and Installation"](#) (with QR25DE), or [EC-1008, "Diagnostic Procedure"](#) (with VQ35DE).
- Tighten front suspension member bolts to the specified torque. Refer to [FSU-14, "FRONT SUSPENSION MEMBER"](#).
- Tighten rear plate cover bolts to the specified torque. Refer to [AT-272, "OVERHAUL"](#).

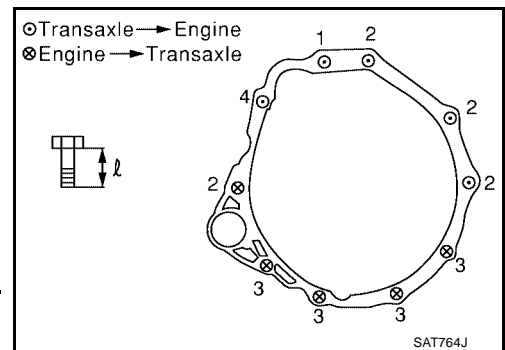

SAT764J

Bolt No.	Tightening torque N-m (kg-m, ft-lb)	l mm (in)
1	70 - 79 (7.1 - 8.1, 52 - 58)	65 (2.56)
2	70 - 79 (7.1 - 8.1, 52 - 58)	52 (2.05)
3	70 - 79 (7.1 - 8.1, 52 - 58)	40 (1.57)
4	78 - 98 (7.9 - 10.0, 58 - 72)	124 (4.88)

- Reinstall any part removed.
- Reconnect electrical connectors.

REMOVAL AND INSTALLATION

- Check fluid level in transaxle.
- Move selector lever through all positions to be sure that transaxle operates correctly.
With parking brake applied, rotate engine at idling. Move selector lever through N to D, to 2, to 1 and to R position. A slight shock should be felt by hand gripping selector each time transaxle is shifted.
- Perform road test. Refer to [AT-66, "Road Test"](#) .

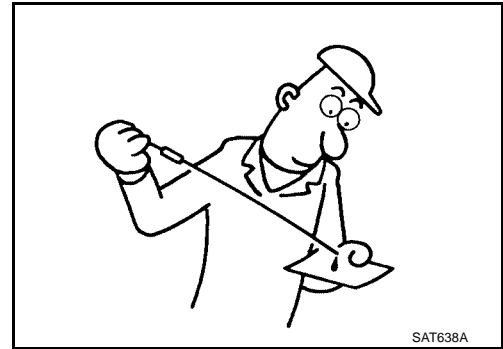

A

B

AT

D

E

F

G

H

I

J

K

L

M

OVERHAUL

PFP:00000

ECS006F7

OVERHAUL Components

SEC. 311•313•327•381

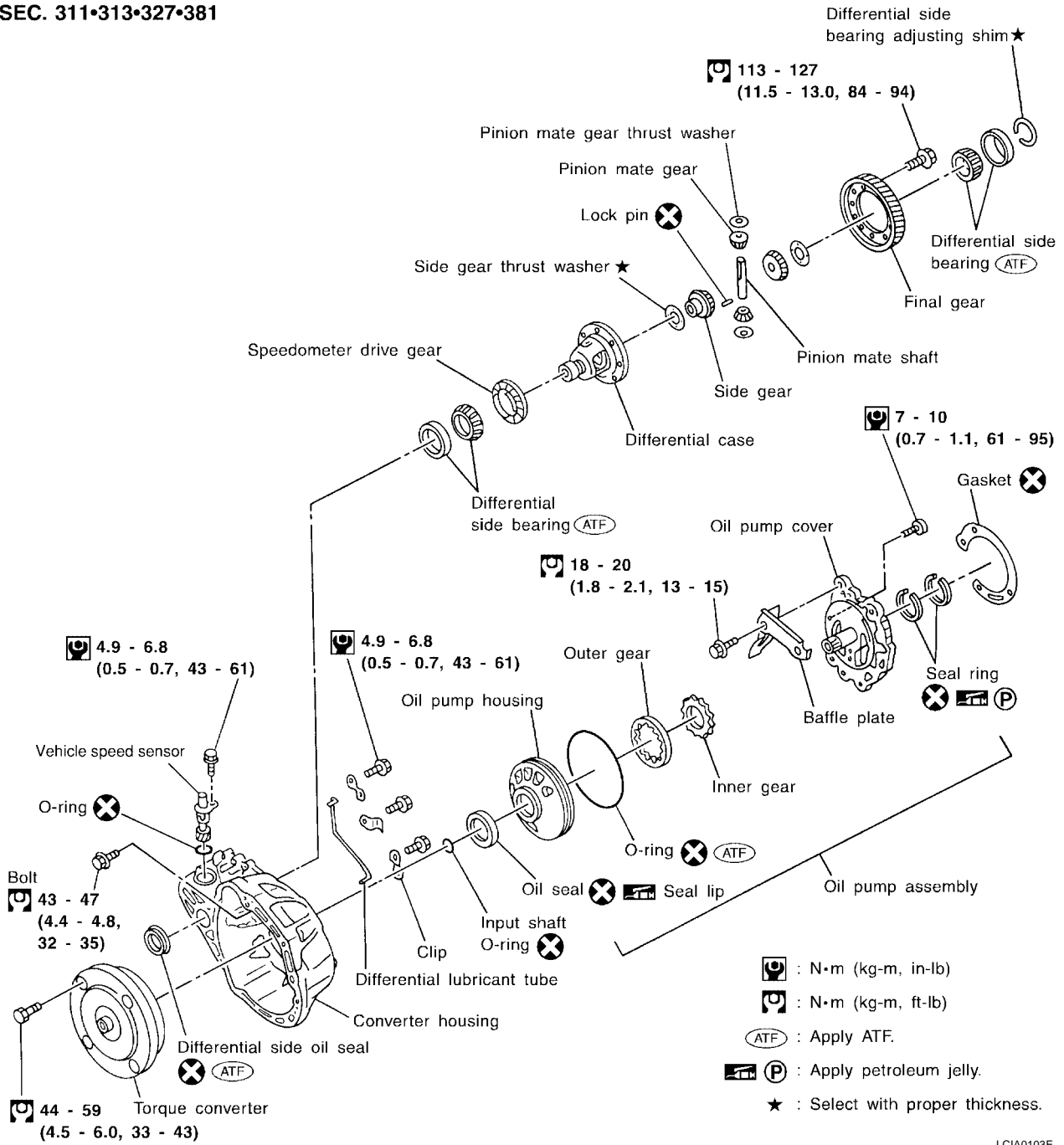

LCIA0103E

OVERHAUL

ECS006F8

Oil Channel

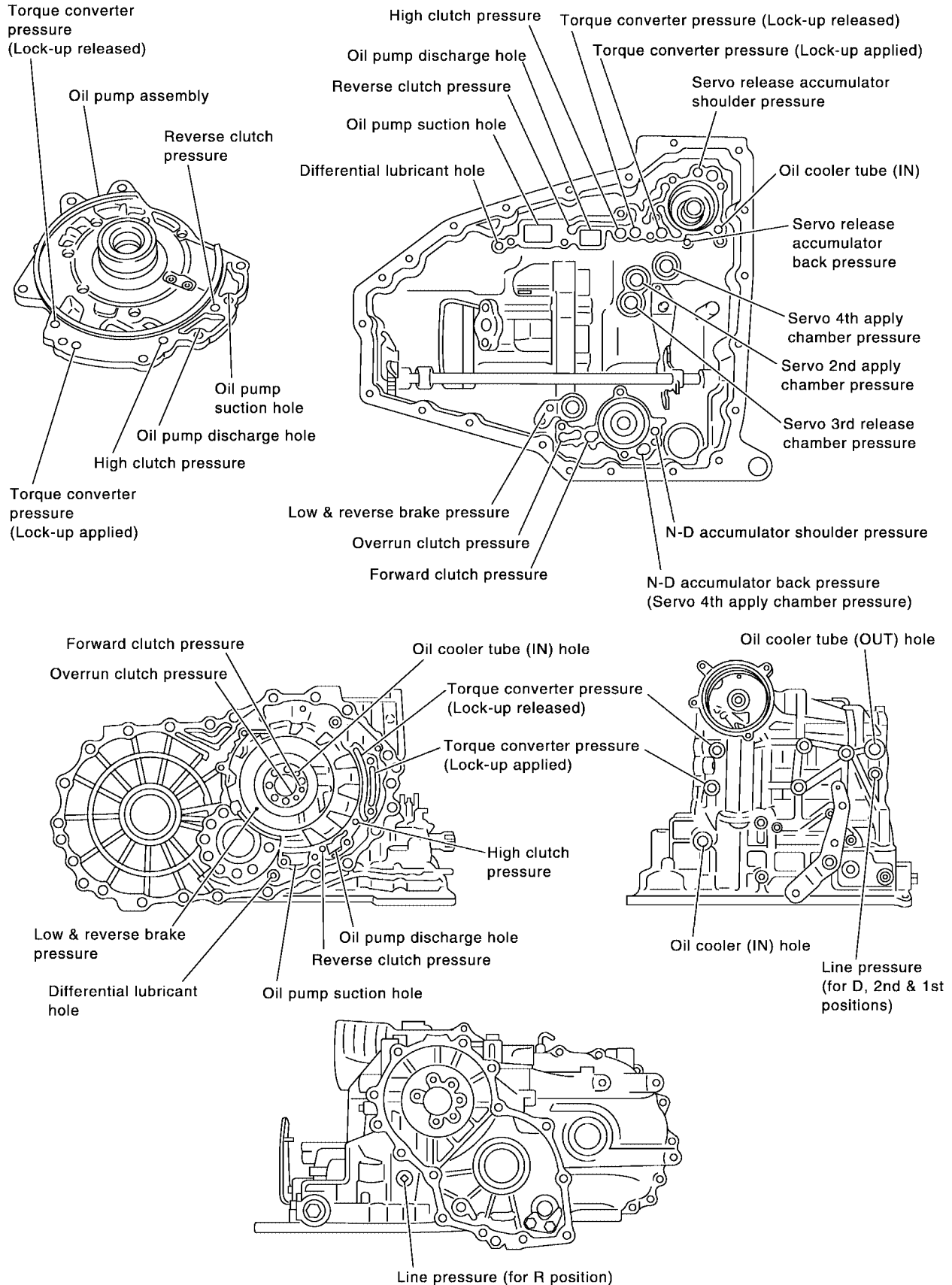

SAT573K

OVERHAUL

Locations of Adjusting Shims, Needle Bearings, Thrust Washers and Snap Rings

ECS006F9

Outer diameter of thrust washers

Item number	Outer diameter mm (in)	Parts number*
J ★	76.0 (2.992)	31508 80X13 - 31508 80X20
K ★	80.0 (3.150)	31438 80X60 - 31438 80X70

Outer and inner diameter of needle bearings

Item number	Outer diameter mm (in)	Inner diameter mm (in)	Parts number*
A	50.0 (1.969)	35.1 (1.382)	31407 80X10
B	42.0 (1.654)	23.7 (0.933)	31407 80X01
C	70.0 (2.756)	50.0 (1.969)	31407 80X09
D	51.0 (2.008)	33.1 (1.303)	31407 80X02
E	48.0 (1.890)	30.0 (1.181)	31407 80X03
F	50.0 (1.969)	35.1 (1.382)	31407 80X10
G	56.5 (2.224)	38.5 (1.516)	31407 80X08
H	87.0 (3.425)	69.0 (2.717)	31407 80X07
I	108.0 (4.252)	85.15 (3.3524)	31407 80X06

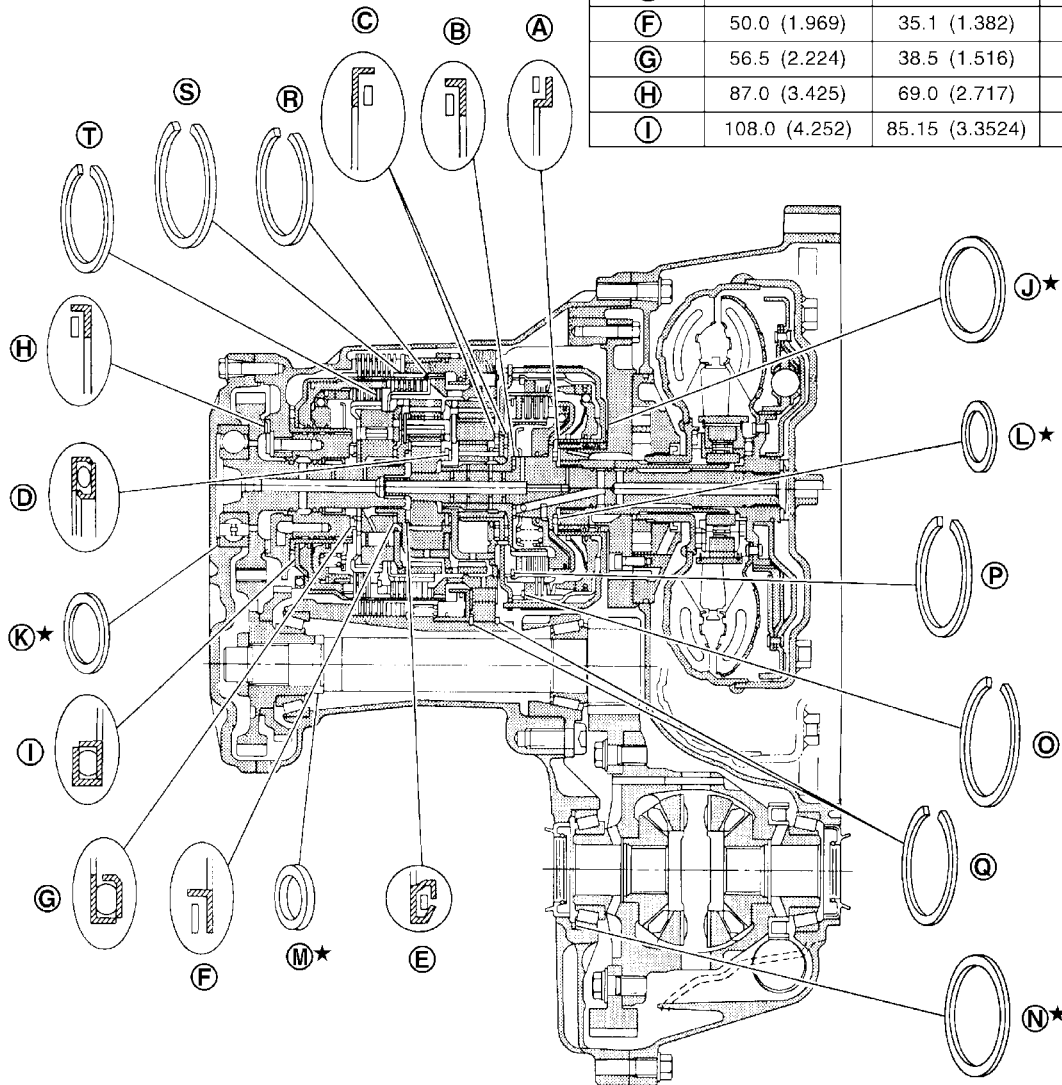

Outer & inner diameter of bearing races, adjusting shims and adjusting spacer

Item number	Outer diameter mm (in)	Inner diameter mm (in)	Parts number*
L ★	51.0 (2.008)	36.0 (1.417)	31435 80X00 - 31439 80X14
M ★	38.0 (1.496)	28.1 (1.106)	31439 85X01 - 31439 85X06 31439 83X11 - 31439 83X24 31439 81X00 - 31439 81X24 31439 81X46 - 31439 81X49 31439 81X60 - 31439 81X74
N ★	75.0 (2.953)	67.0 (2.638)	31438 80X00 - 31439 80X11

Outer diameter of snap rings

Item number	Outer diameter mm (in)	Parts number*
O	150 (5.91)	31506 80X13
P	119.1 (4.689)	31506 80X06
Q	182.8 (7.197)	31506 80X08
R	144.8 (5.701)	31506 80X03
S	173.8 (6.843)	31506 80X09
T	133.9 (5.272)	31506 80X01

★ : Select proper thickness.

* : Always check with the Parts Department for the latest parts information.

SAT565K

DISASSEMBLY

DISASSEMBLY

PFP:31020

ECS006FA

Disassembly

1. Drain ATF through drain plug.
2. Remove torque converter.

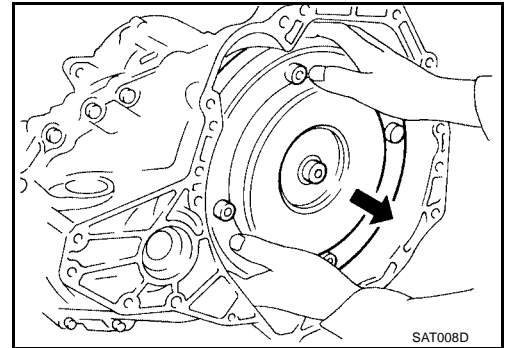

3. Check torque converter one-way clutch using check tool as shown at left.
 - a. Insert check tool into the groove of bearing support built into one-way clutch outer race.
 - b. When fixing bearing support with check tool, rotate one-way clutch spline using screwdriver.
 - c. Check that inner race rotates clockwise only. If not, replace torque converter assembly.

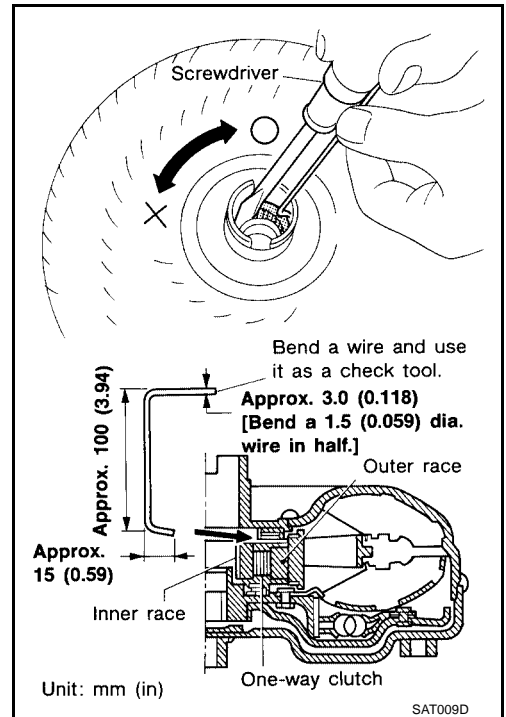

4. Remove A/T fluid charging pipe and fluid cooler tube.

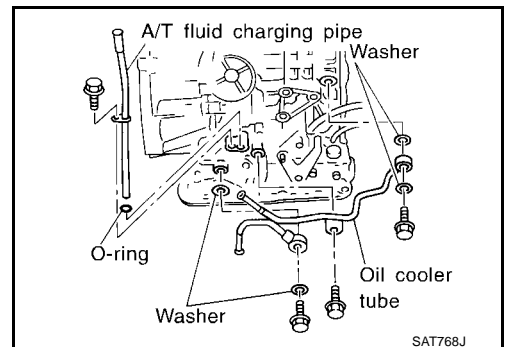

DISASSEMBLY

5. Set manual shaft to position P.
6. Remove park/neutral position (PNP) switch.

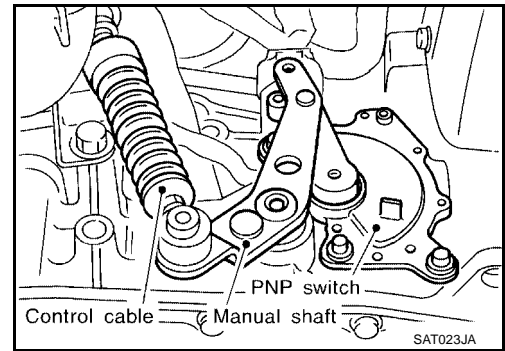

7. Remove oil pan using power tools, and oil pan gasket.
 - Do not reuse oil pan bolts.
8. Check foreign materials in oil pan to help determine causes of malfunction. If the fluid is very dark, smells burned, or contains foreign particles, the frictional material (clutches, band) may need replacement. A tacky film that will not wipe clean indicates varnish build up. Varnish can cause valves, servo, and clutches to stick and can inhibit pump pressure.
 - If frictional material is detected, replace radiator after repair of A/T. Refer to [CO-10, "RADIATOR"](#) (with QR25DE), or [CO-31, "RADIATOR"](#) (with VQ35DE).

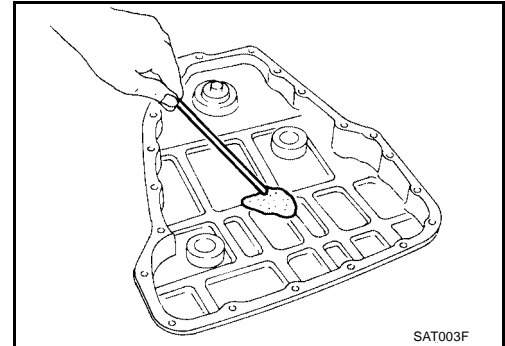

9. Remove control valve assembly according to the following procedures.
 - a. Remove control valve assembly mounting bolts I, X and ●.

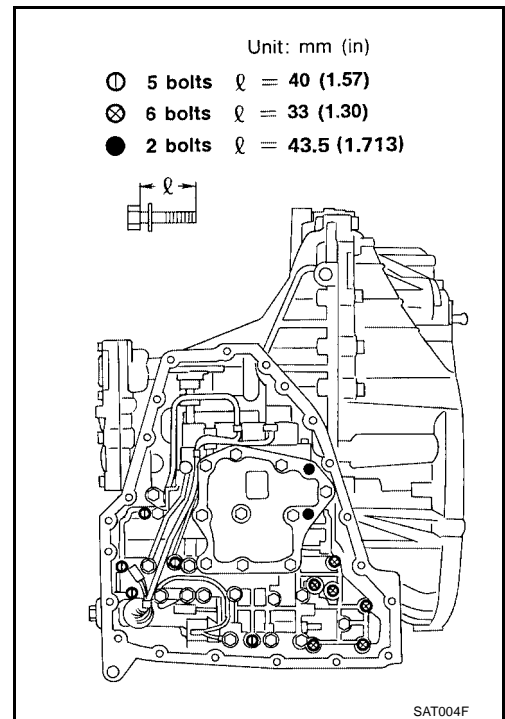

- b. Remove snap ring from terminal body.

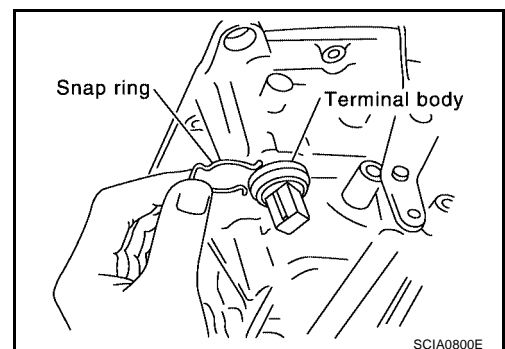

DISASSEMBLY

- c. Push terminal body into transmission case and draw out terminal cord assembly.

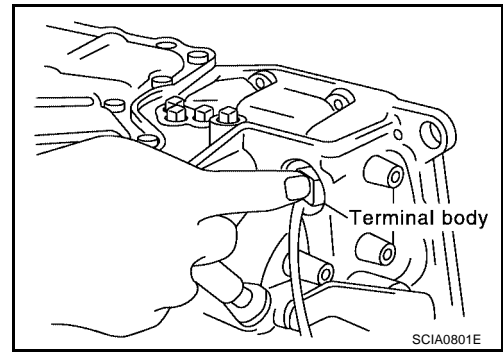

10. Remove manual valve from control valve assembly.

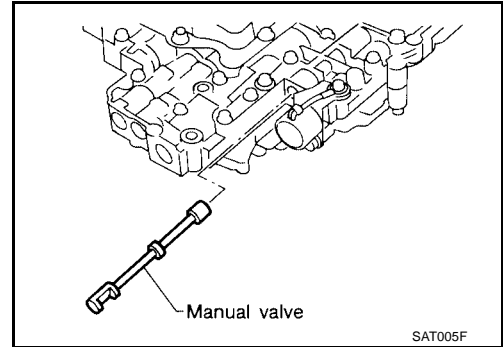

11. Remove return spring from servo release accumulator piston.

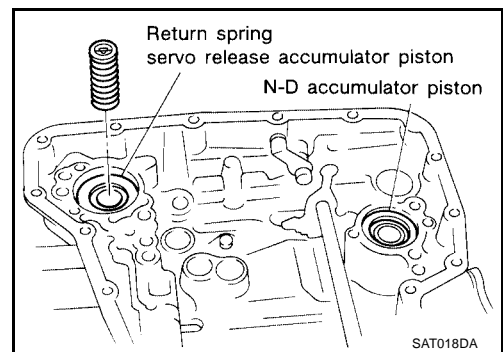

12. Remove servo release accumulator piston with compressed air.

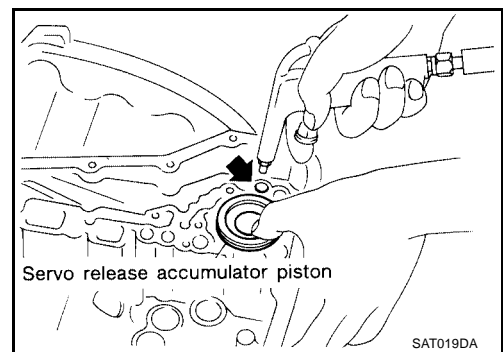

13. Remove O-rings from servo release accumulator piston.

A
B
AT
D
E
F
G
H
I
J
K
L
M

DISASSEMBLY

14. Remove N-D accumulator piston and return spring with compressed air.

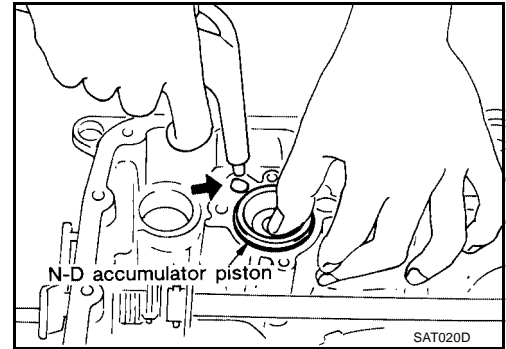

15. Remove O-rings from N-D accumulator piston.
16. Check accumulator pistons and contact surface of transmission case for damage.

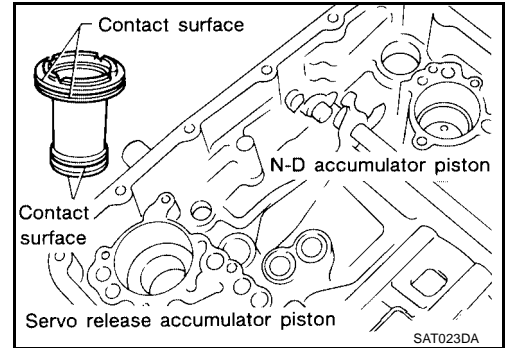

17. Check accumulator return springs for damage and free length.
18. Remove lip seals.

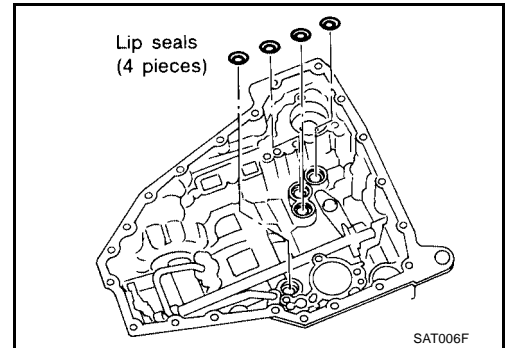

19. Remove L & R oil tube and oil sleeve.

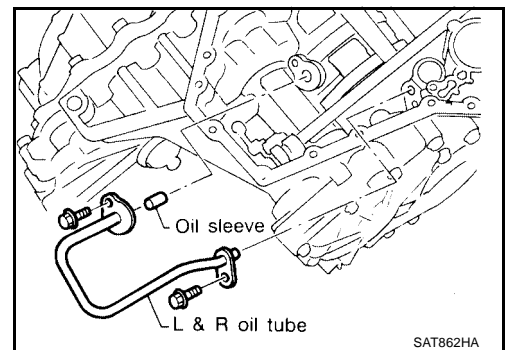

DISASSEMBLY

20. Remove converter housing according to the following procedures.
- Remove converter housing mounting bolts using power tools.
 - Remove converter housing by tapping it lightly.

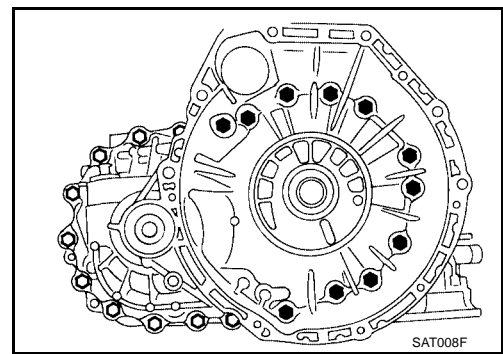

- Remove O-ring from differential oil port.

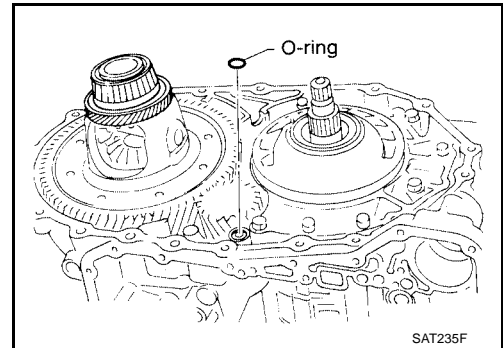

21. Remove final drive assembly from transmission case.

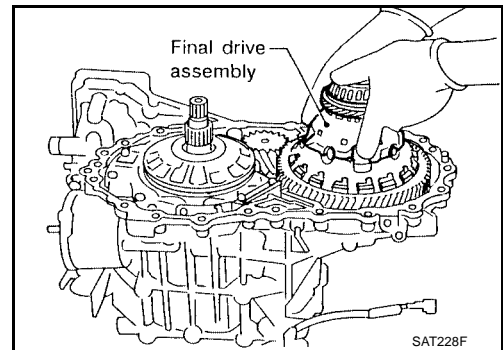

22. Remove differential side bearing outer race and side bearing adjusting shim from transmission case.

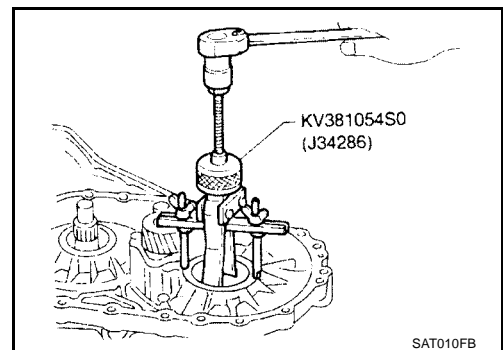

23. Remove differential side bearing adjusting shim from transmission case.

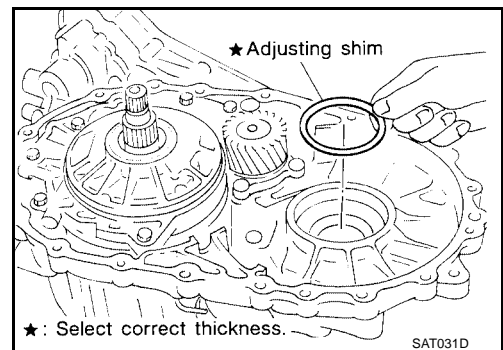

A
B
AT
D
E
F
G
H
I
J
K
L
M

DISASSEMBLY

24. Remove differential side bearing outer race from converter housing.

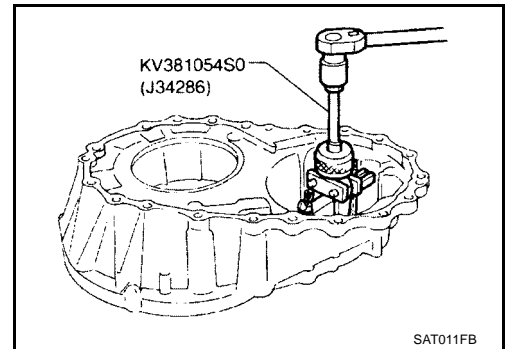

25. Remove oil seal with screwdriver from converter housing.
● Be careful not to damage case.

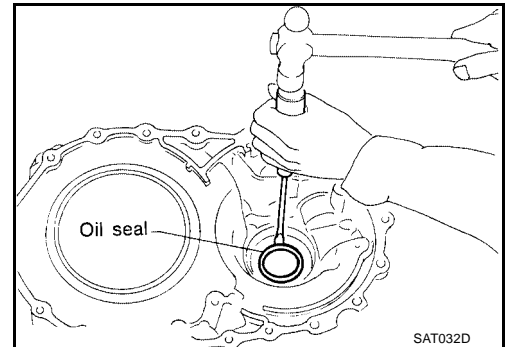

26. Remove differential lubricant tube from converter housing.

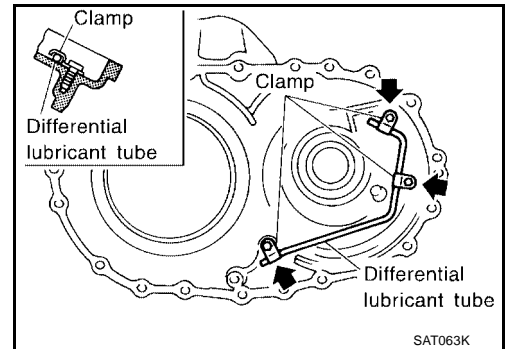

27. Remove oil pump according to the following procedures.
a. Remove O-ring from input shaft.

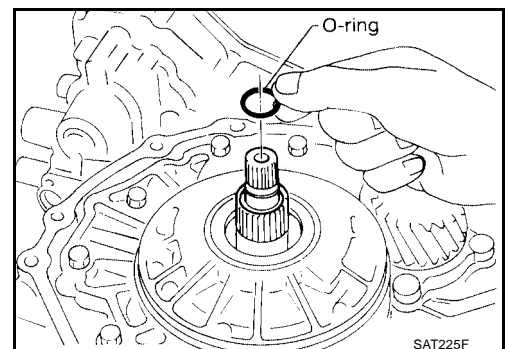

b. Remove oil pump assembly, baffle plate and gasket from transmission case.

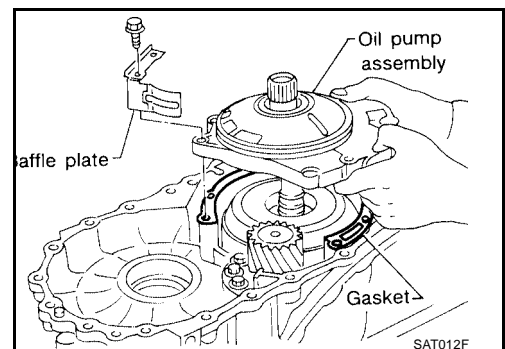

DISASSEMBLY

- c. Remove thrust washer and bearing race from oil pump assembly.

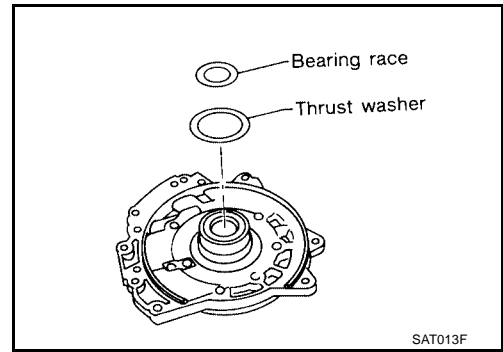

28. Remove brake band according to the following procedures.

- a. Loosen lock nut, then back off anchor end pin.

- Do not reuse anchor end pin.

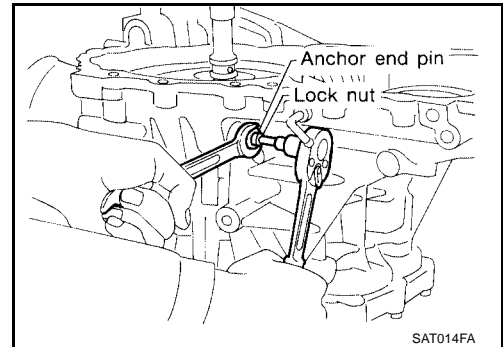

- b. Remove brake band and strut from transmission case.

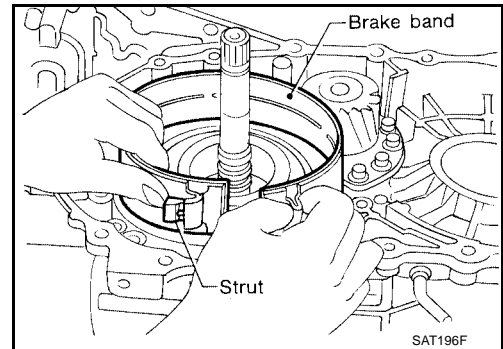

- To prevent brake linings from cracking or peeling, do not stretch the flexible band unnecessarily. When removing the brake band, always secure it with a clip as shown in the figure at left. Leave the clip in position after removing the brake band.

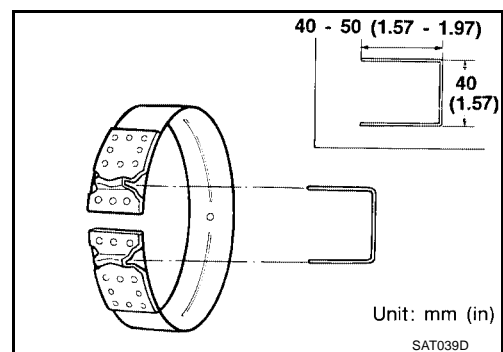

- c. Check brake band facing for damage, cracks, wear or burns.

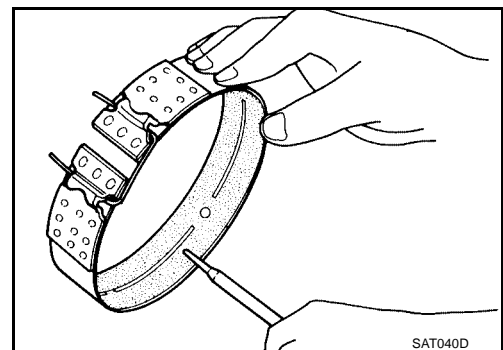

A
B
AT
D
E
F
G
H
I
J
K
L
M

DISASSEMBLY

29. Remove input shaft assembly (high clutch) and reverse clutch according to the following procedures.

a. Remove input shaft assembly (high clutch) with reverse clutch.

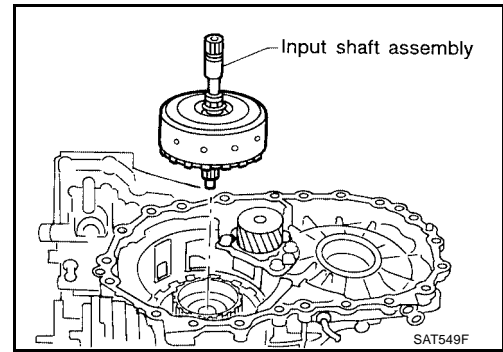

b. Remove input shaft assembly (high clutch) from reverse clutch.

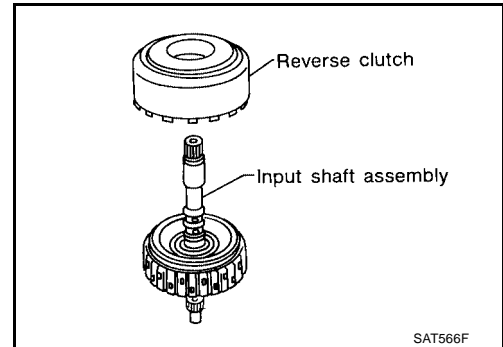

c. Remove needle bearings from high clutch drum and check for damage or wear.

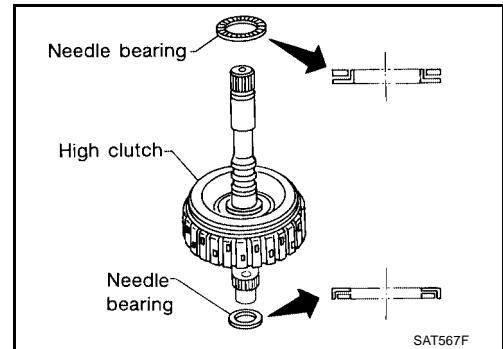

d. Remove high clutch hub and front sun gear from transmission case.

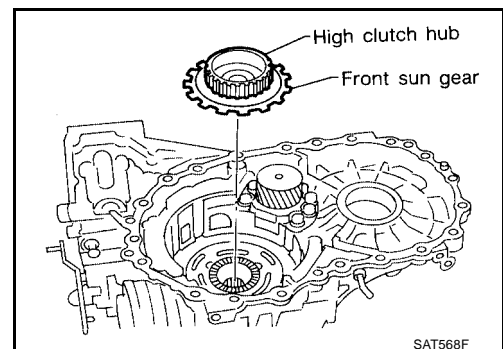

e. Remove front sun gear and needle bearing from high clutch hub and check for damage or wear.

f. Remove bearing race from front sun gear and check for damage or wear.

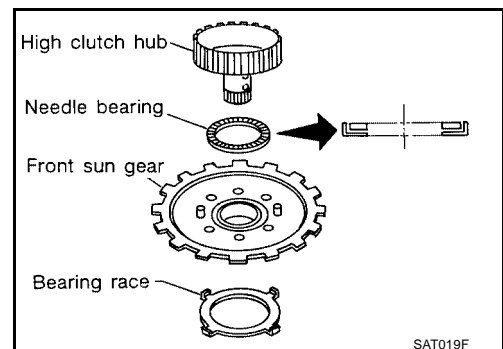

DISASSEMBLY

30. Remove needle bearing from transmission case and check for damage or wear.

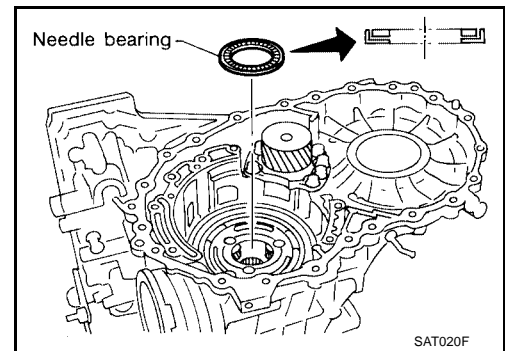

31. Apply compressed air and check to see that low and reverse brake operates.

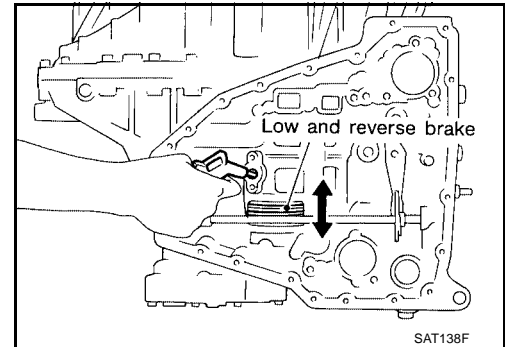

32. Remove low one-way clutch and front planetary carrier assembly according to the following procedures.

- a. Remove snap ring with flat-bladed screwdriver.

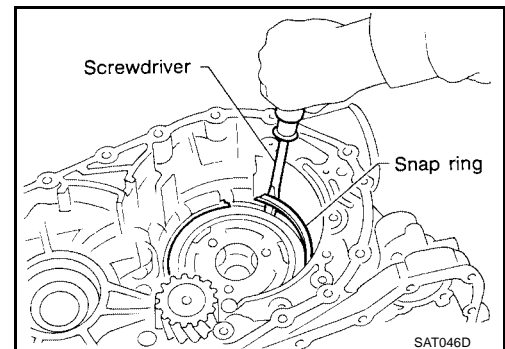

- b. Remove low one-way clutch with a hook made of wire.

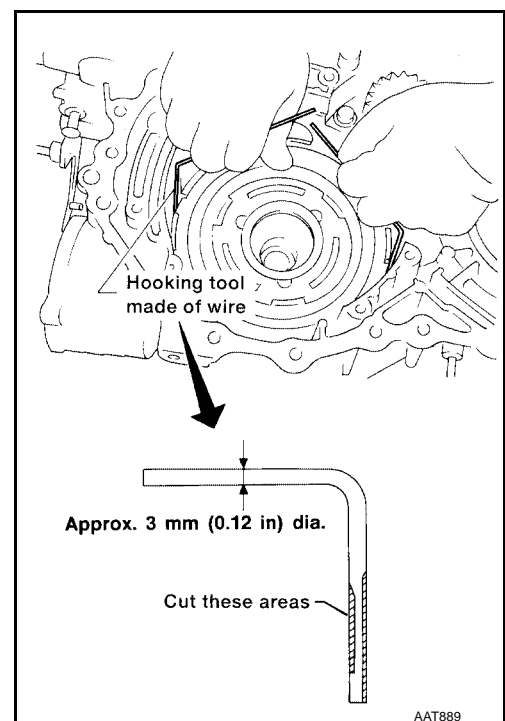

DISASSEMBLY

- c. Remove snap ring with flat-bladed screwdriver.

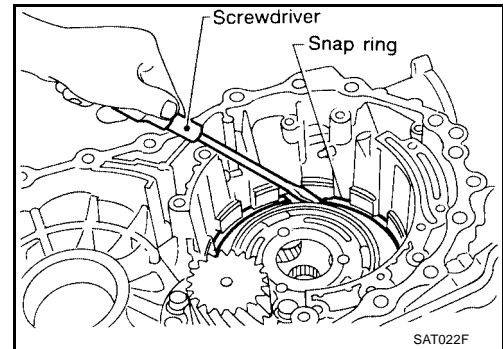

- d. Remove front planetary carrier with low and reverse brake piston and retainer.

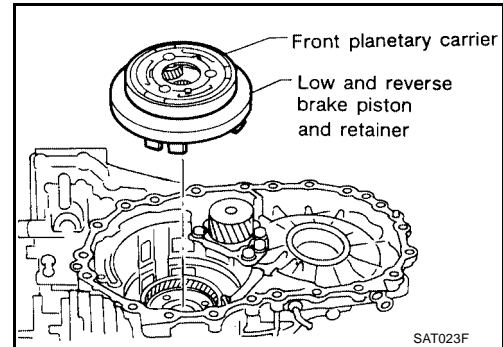

- e. Remove low and reverse brake spring retainer.
● Do not remove return springs from spring retainer.

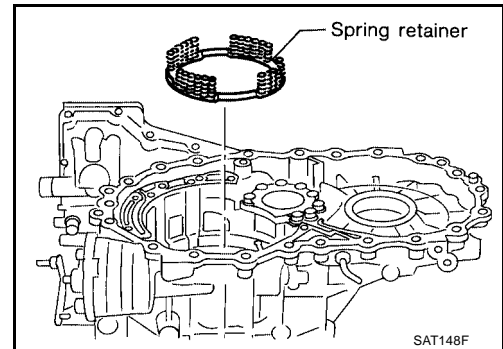

- f. Check that low one-way clutch rotates in the direction of the clockwise arrow and locks in the opposite direction.

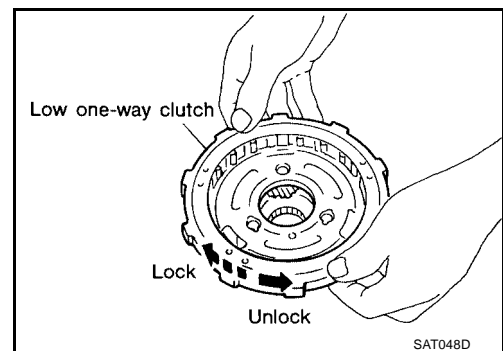

- g. Remove needle bearing, low and reverse brake piston and retainer from front planetary carrier.
h. Check front planetary carrier, low one-way clutch and needle bearing for damage or wear.

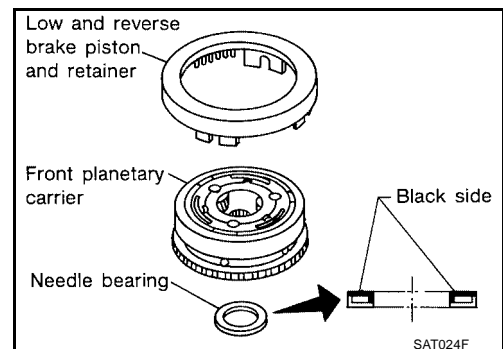

DISASSEMBLY

- i. Check clearance between planetary gears and planetary carrier with feeler gauge.

Standard clearance : 0.20 - 0.70 mm
(0.0079 - 0.0276 in)

Allowable limit : 0.80 mm (0.0315 in)

Replace front planetary carrier if the clearance exceeds allowable limit.

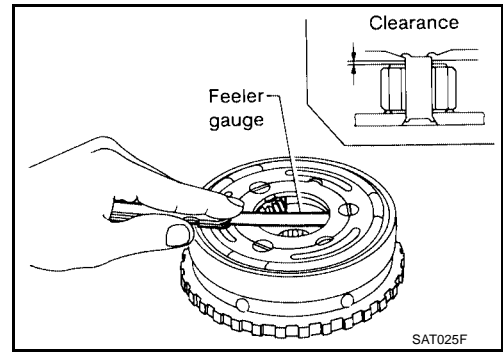

33. Remove rear planetary carrier assembly and rear sun gear according to the following procedures.

- a. Remove rear planetary carrier assembly from transmission case.

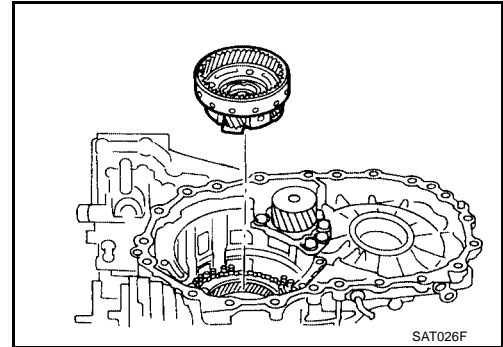

- b. Remove rear sun gear from rear planetary carrier.

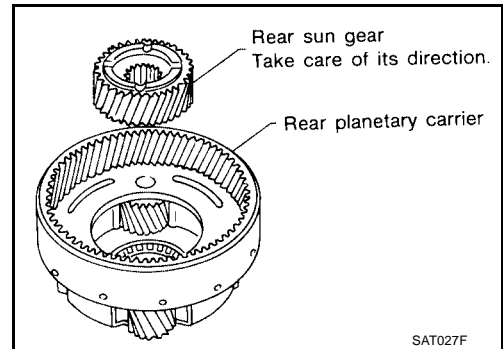

- c. Remove needle bearings from rear planetary carrier assembly.
d. Check rear planetary carrier, rear sun gear and needle bearings for damage or wear.

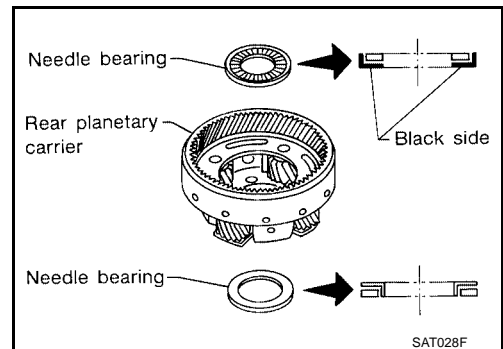

- e. Check clearance between pinion washer and rear planetary carrier with feeler gauge.

Standard clearance : 0.20 - 0.70 mm
(0.0079 - 0.0276 in)

Allowable limit : 0.80 mm (0.0315 in)

Replace rear planetary carrier if the clearance exceeds allowable limit.

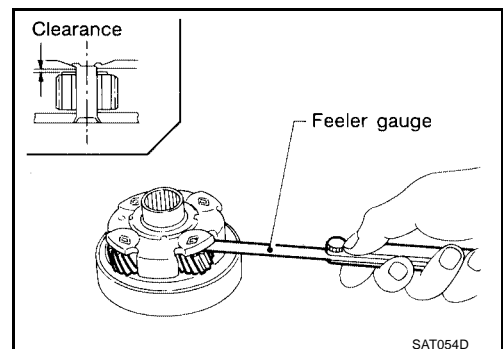

DISASSEMBLY

34. Remove rear internal gear and forward clutch hub from transmission case.

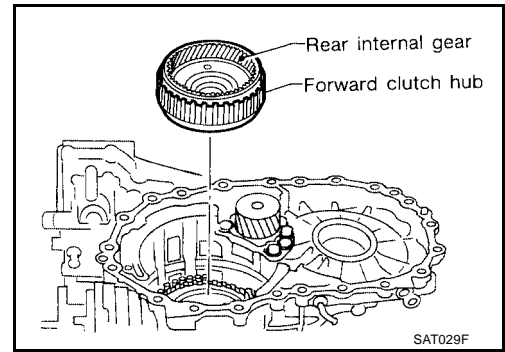

35. Remove overrun clutch hub from transmission case.

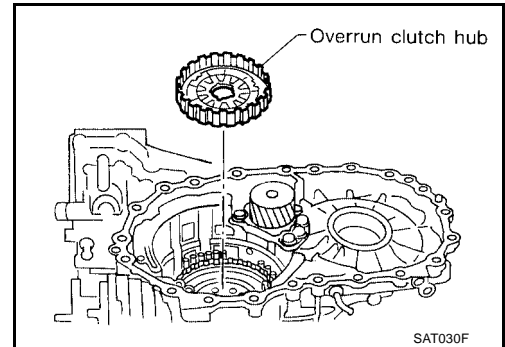

36. Remove needle bearing from overrun clutch hub and check for damage or wear.

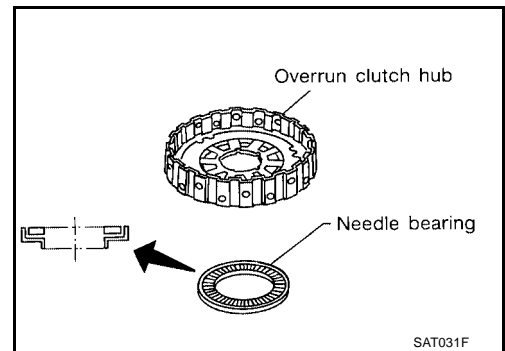

37. Remove forward clutch assembly from transmission case.

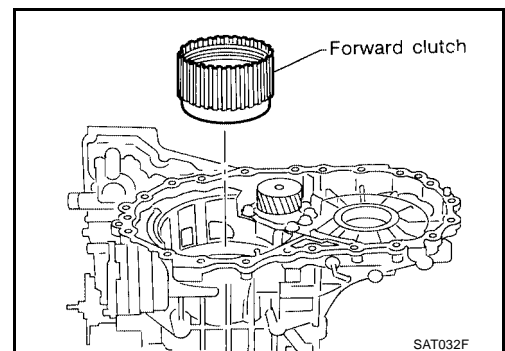

38. Remove needle bearing from transmission case.

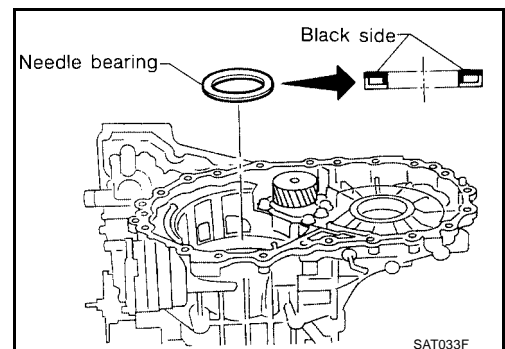

DISASSEMBLY

39. Remove output shaft assembly according to the following procedures.

a. Remove side cover bolts.

- Do not mix bolts A and B.
- Always replace bolts A as they are self-sealing bolts.

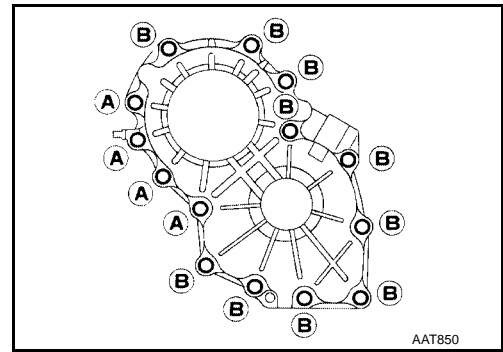

b. Remove side cover by lightly tapping it with a soft hammer.

- Be careful not to drop output shaft assembly. It might come out when removing side cover.

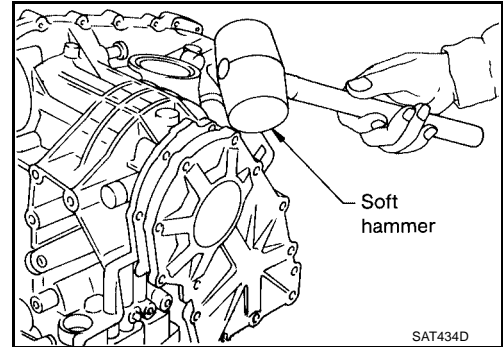

c. Remove adjusting shim.

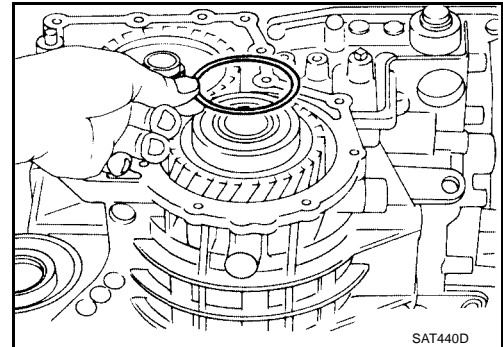

d. Remove output shaft assembly.

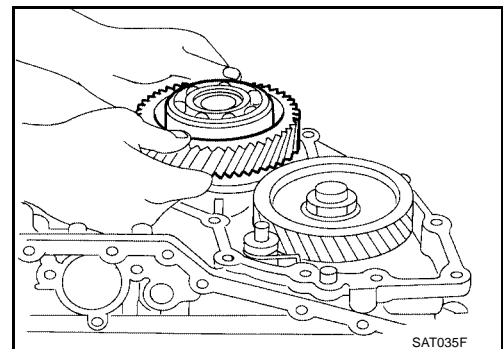

- If output shaft assembly came off with side cover, tap cover with a soft hammer to separate.

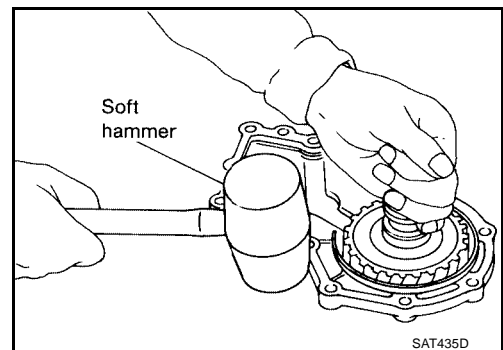

A
B
AT
D
E
F
G
H
I
J
K
L
M

DISASSEMBLY

- e. Remove needle bearing.

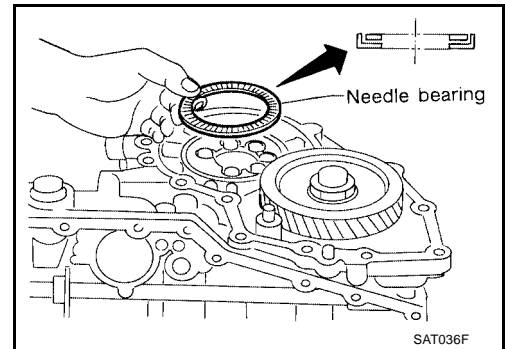

40. Disassemble reduction pinion gear according to the following procedures.

- a. Set manual shaft to position P to fix idler gear.
b. Unlock idler gear lock nut using a pin punch.

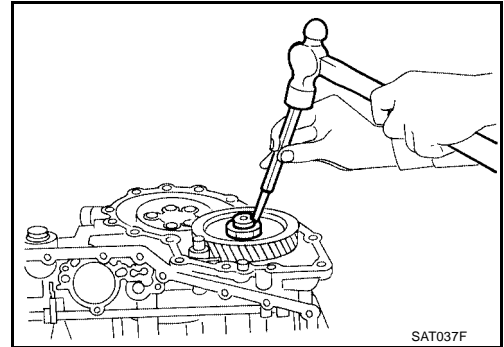

- c. Remove idler gear lock nut.

- Do not reuse idler gear lock nut.

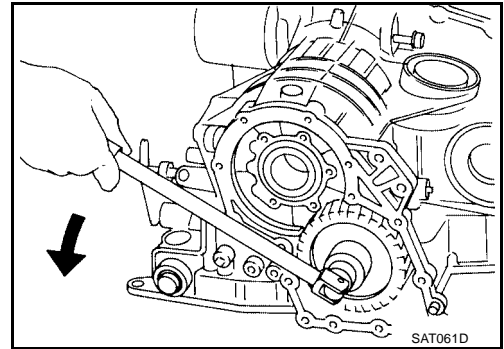

- d. Remove idler gear with puller.

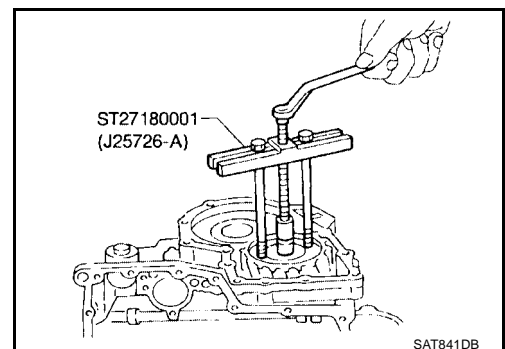

- e. Remove reduction pinion gear.

- f. Remove adjusting shim from reduction pinion gear.

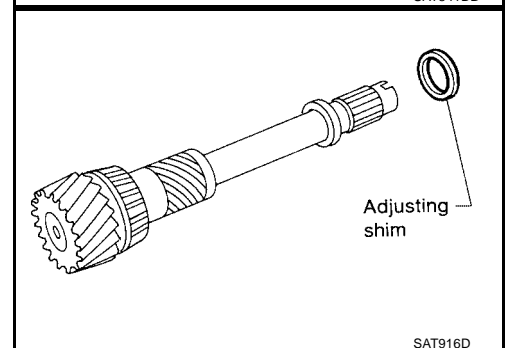

DISASSEMBLY

41. Remove return spring from parking shaft with screwdriver.
42. Draw out parking shaft and remove parking pawl from transmission case.
43. Check parking pawl and shaft for damage or wear.

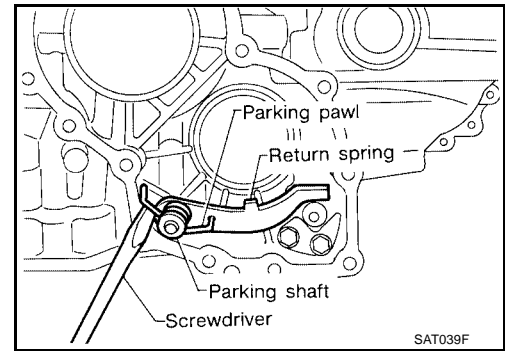

44. Remove parking actuator support from transmission case.
45. Check parking actuator support for damage or wear.

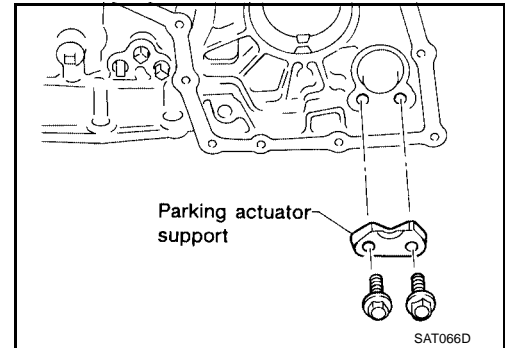

46. Remove side oil seal with screwdriver from transmission case.

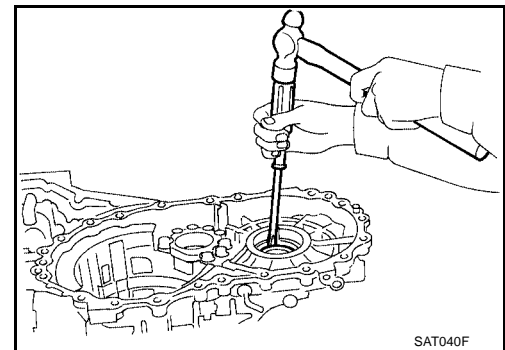

A
B
AT
D
E
F
G
H
I
J
K
L
M

REPAIR FOR COMPONENT PARTS

REPAIR FOR COMPONENT PARTS

PFP:00000

Manual Shaft COMPONENTS

ECS006FB

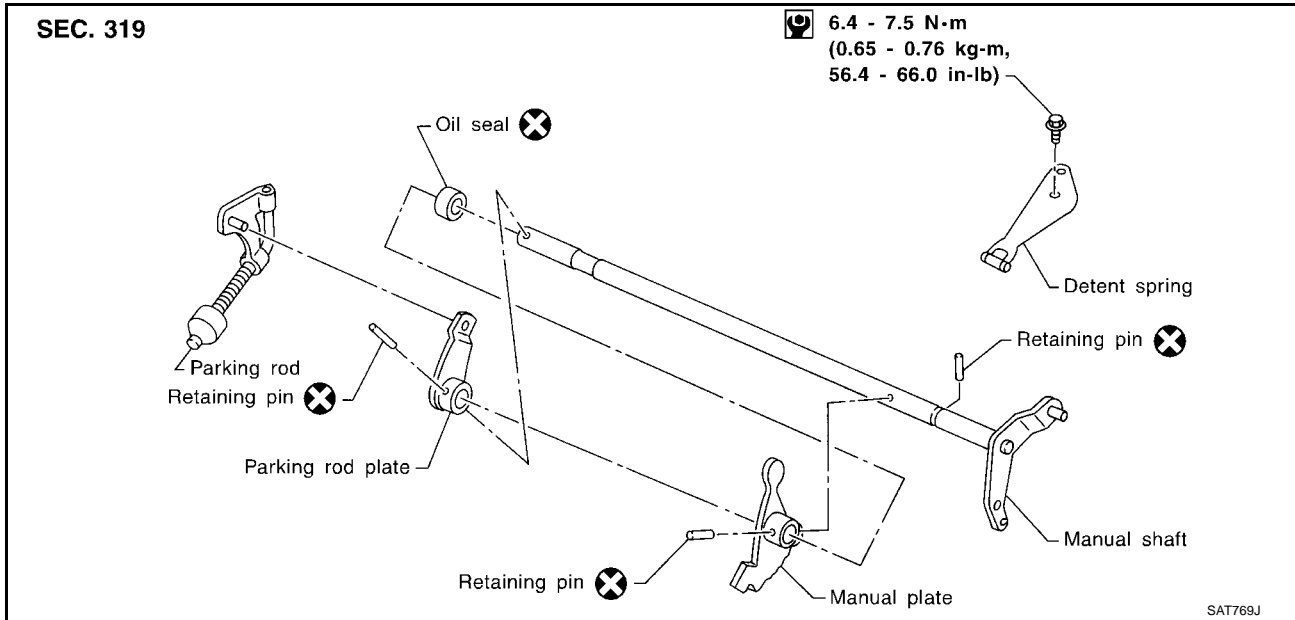

REMOVAL

1. Remove detent spring from transmission case.

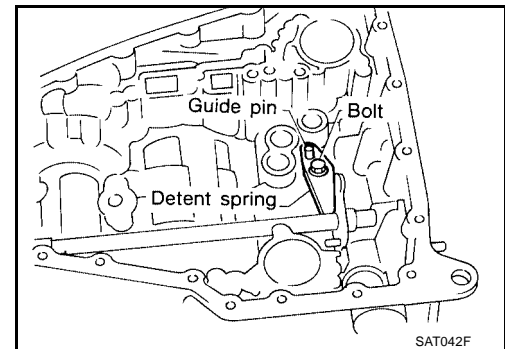

2. Drive out manual plate retaining pin.

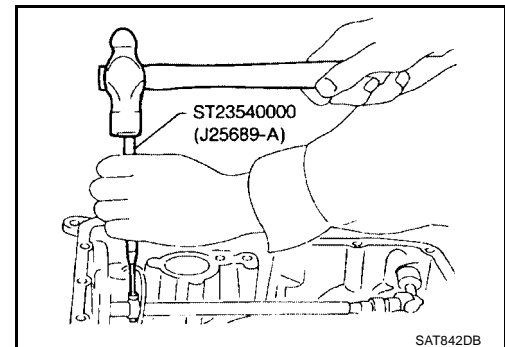

REPAIR FOR COMPONENT PARTS

3. Drive and pull out parking rod plate retaining pin.
4. Remove parking rod plate from manual shaft.
5. Draw out parking rod from transmission case.

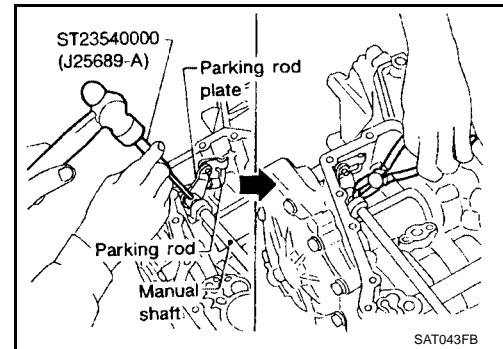

6. Pull out manual shaft retaining pin.
7. Remove manual shaft and manual plate from transmission case.

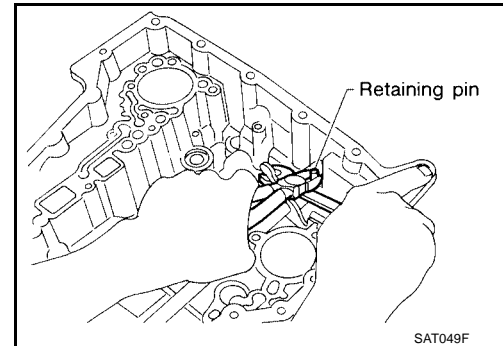

8. Remove manual shaft oil seal.

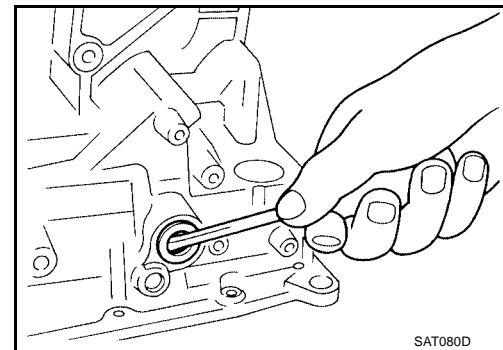

INSPECTION

- Check component parts for wear or damage. Replace if necessary.

INSTALLATION

1. Install manual shaft oil seal.
 - Apply ATF to outer surface of oil seal.

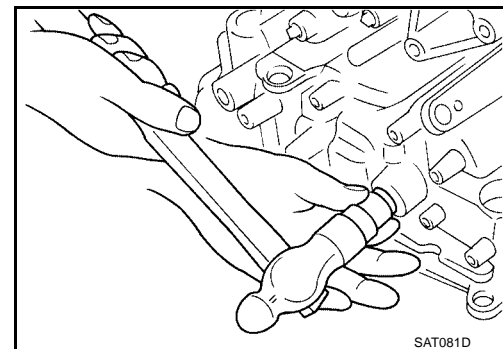

A
B
AT
D
E
F
G
H
I
J
K
L
M

REPAIR FOR COMPONENT PARTS

2. Install manual shaft and manual plate.

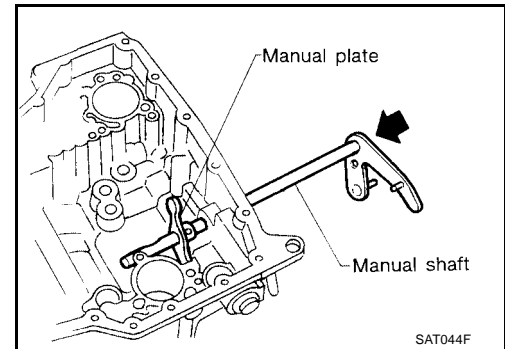

3. Align groove of manual shaft and hole of transmission case.
4. Install manual shaft retaining pin up to bottom of hole.

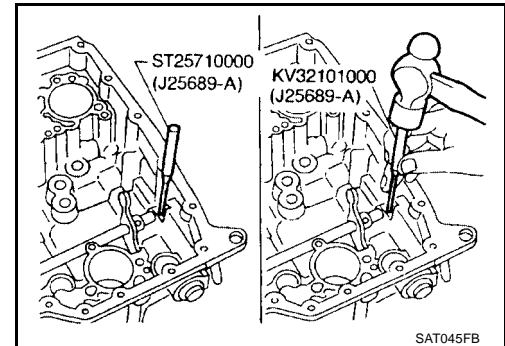

5. Install parking rod to parking rod plate.
6. Set parking rod assembly onto manual shaft and drive retaining pin.
- Both ends of pin should protrude.

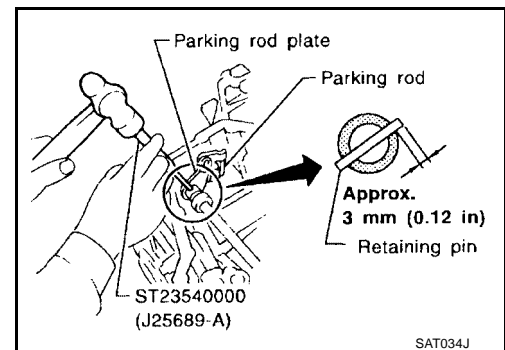

7. Drive manual plate retaining pin.
- Both ends of pin should protrude.

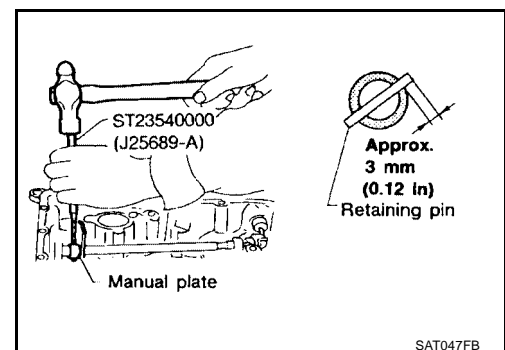

8. Install detent spring. Tighten detent spring bolts to the specified torque. Refer to [AT-292, "COMPONENTS"](#).

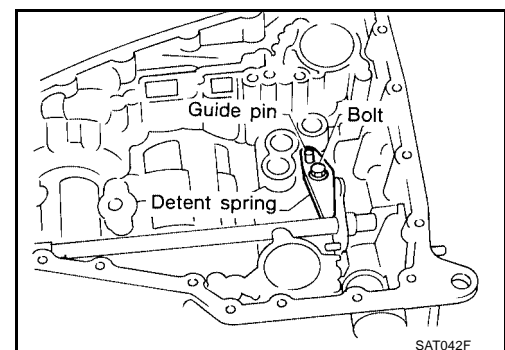

REPAIR FOR COMPONENT PARTS

Oil Pump COMPONENTS

ECS006FC

SEC. 313

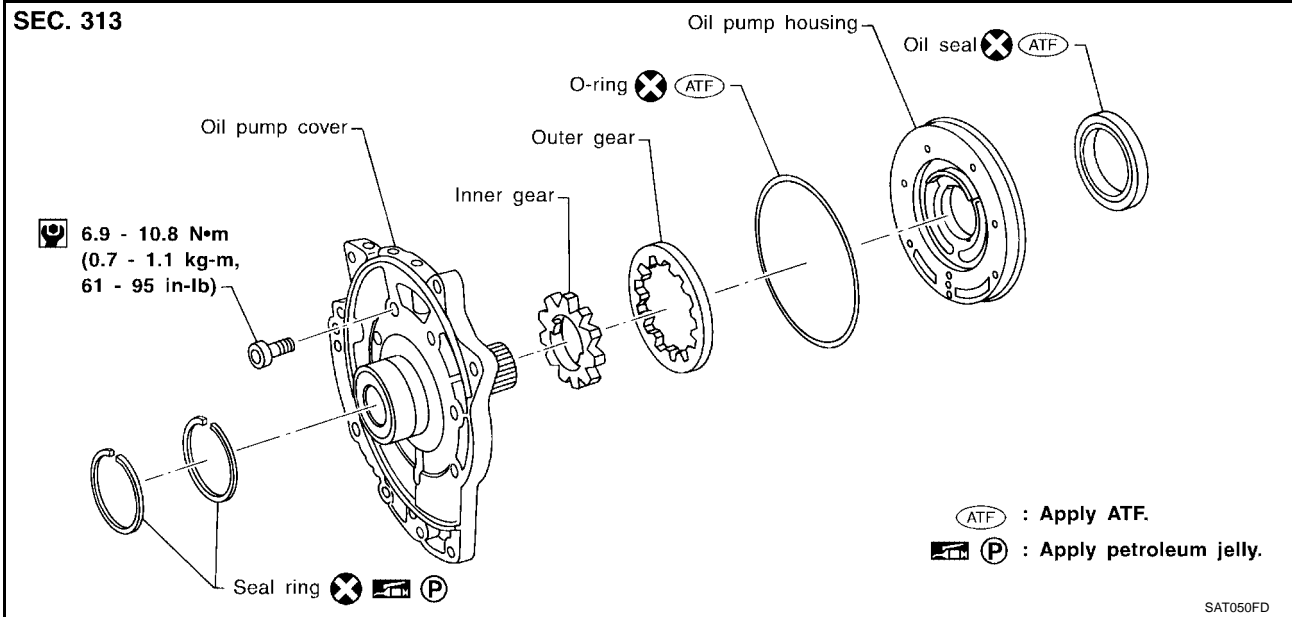

DISASSEMBLY

1. Remove seal rings.

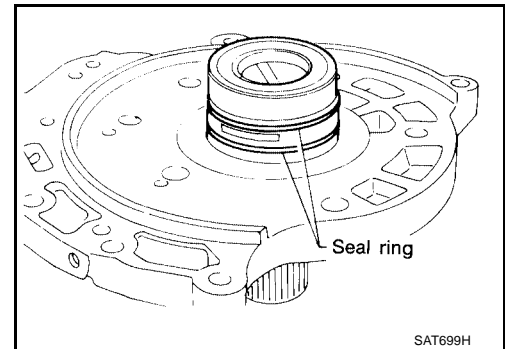

2. Loosen bolts in a crisscross pattern and remove oil pump cover.

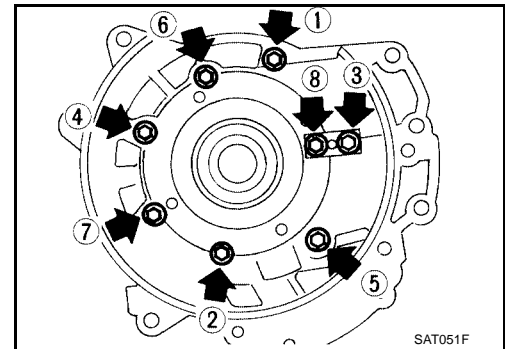

3. Remove inner and outer gear from oil pump housing.

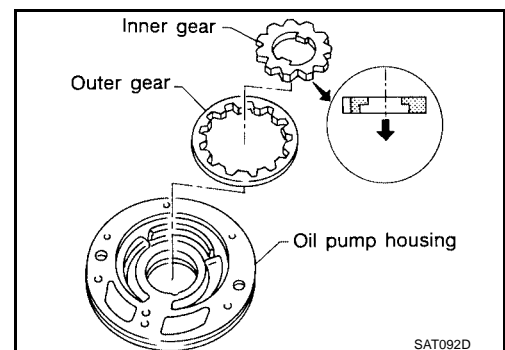

A
B
AT
D
E
F
G
H
I
J
K
L
M

REPAIR FOR COMPONENT PARTS

4. Remove O-ring from oil pump housing.

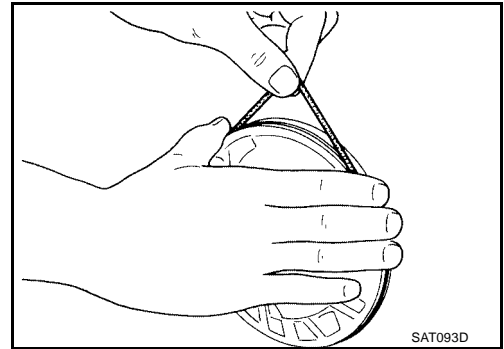

5. Remove oil pump housing oil seal.

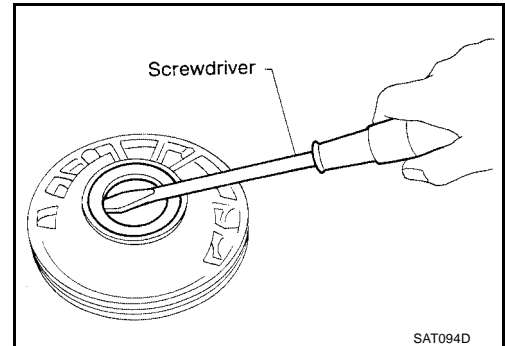

INSPECTION

Oil Pump Housing, Oil Pump Cover, Inner Gear and Outer Gear

- Check for wear or damage.

Side Clearances

- Measure side clearance of inner and outer gears in at least four places around each outside edge. Maximum measured values should be within specified positions.

**Standard clearance : 0.030 - 0.050 mm
(0.0012 - 0.0020 in)**

- If clearance is less than standard, select inner and outer gear as a set so that clearance is within specifications.

Inner and outer gear:

Refer to [AT-373, "SERVICE DATA AND SPECIFICATIONS \(SDS\)"](#).

- If clearance is more than standard, replace whole oil pump assembly except oil pump cover.

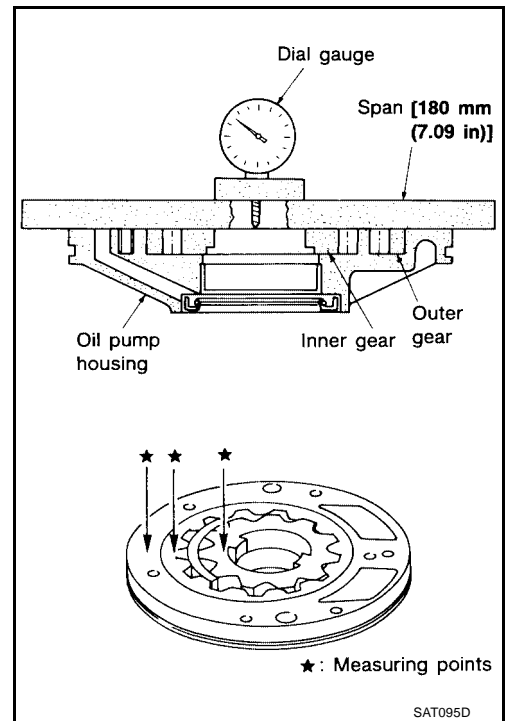

REPAIR FOR COMPONENT PARTS

- Measure clearance between outer gear and oil pump housing.

Standard clearance : 0.111 - 0.181 mm
(0.0044 - 0.0071 in)

Allowable limit : 0.181 mm (0.0071 in)

- If not within allowable limit, replace whole oil pump assembly except oil pump cover.

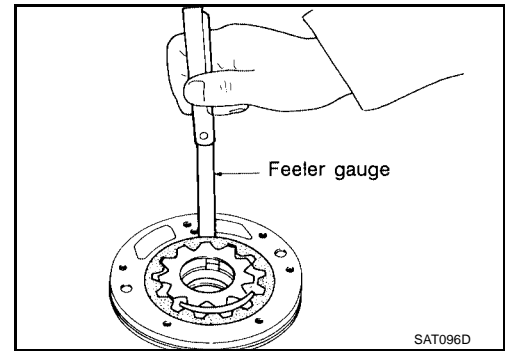

Seal Ring Clearance

- Measure clearance between seal ring and ring groove.

Standard clearance : 0.1 - 0.25 mm (0.0039 - 0.0098 in)

Allowable limit : 0.25 mm (0.0098 in)

- If not within allowable limit, replace oil pump cover assembly.

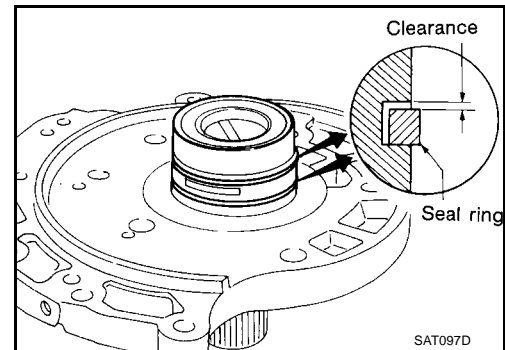

ASSEMBLY

1. Install oil seal on oil pump housing.

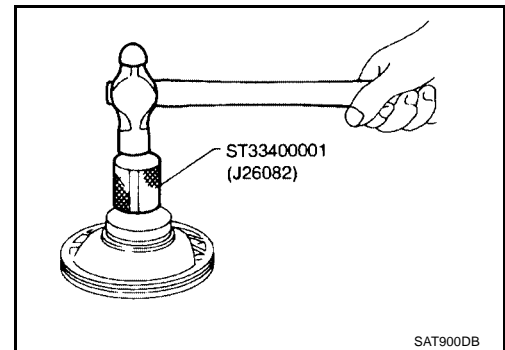

2. Install O-ring on oil pump housing.
 - Apply ATF to O-ring.

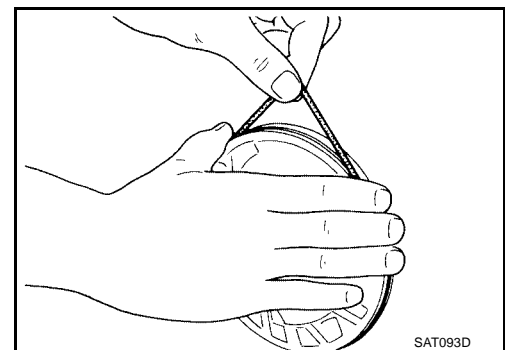

A
B
AT
D
E
F
G
H
I
J
K
L
M

REPAIR FOR COMPONENT PARTS

3. Install inner and outer gears on oil pump housing.

- Be careful of direction of inner gear.

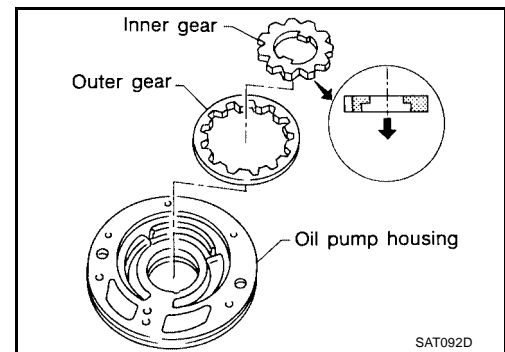

4. Install oil pump cover on oil pump housing.

- Wrap masking tape around splines of oil pump cover assembly to protect seal. Position oil pump cover assembly on oil pump housing assembly, then remove masking tape.
- Tighten bolts in a crisscross pattern. Tighten oil pump cover bolts to the specified torque. Refer to [AT-295, "COMPONENTS"](#)

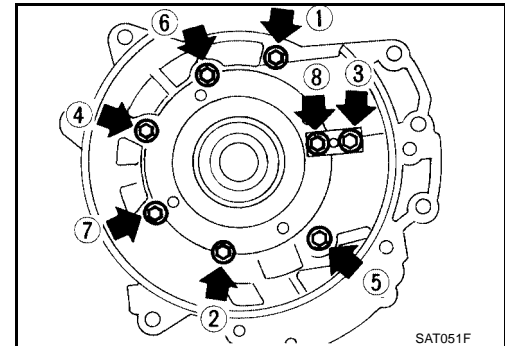

5. Install new seal rings carefully after packing ring groove with petroleum jelly.

- Do not spread gap of seal ring excessively while installing. The ring may be deformed.

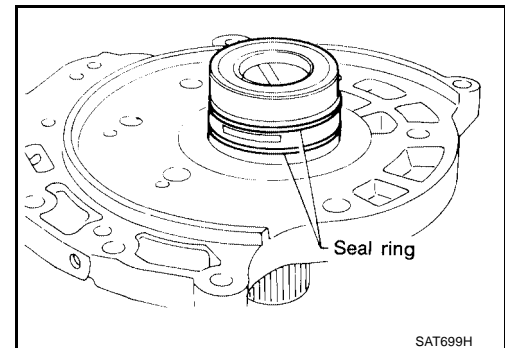

REPAIR FOR COMPONENT PARTS

ECS006FD

Control Valve Assembly COMPONENTS

SEC. 317

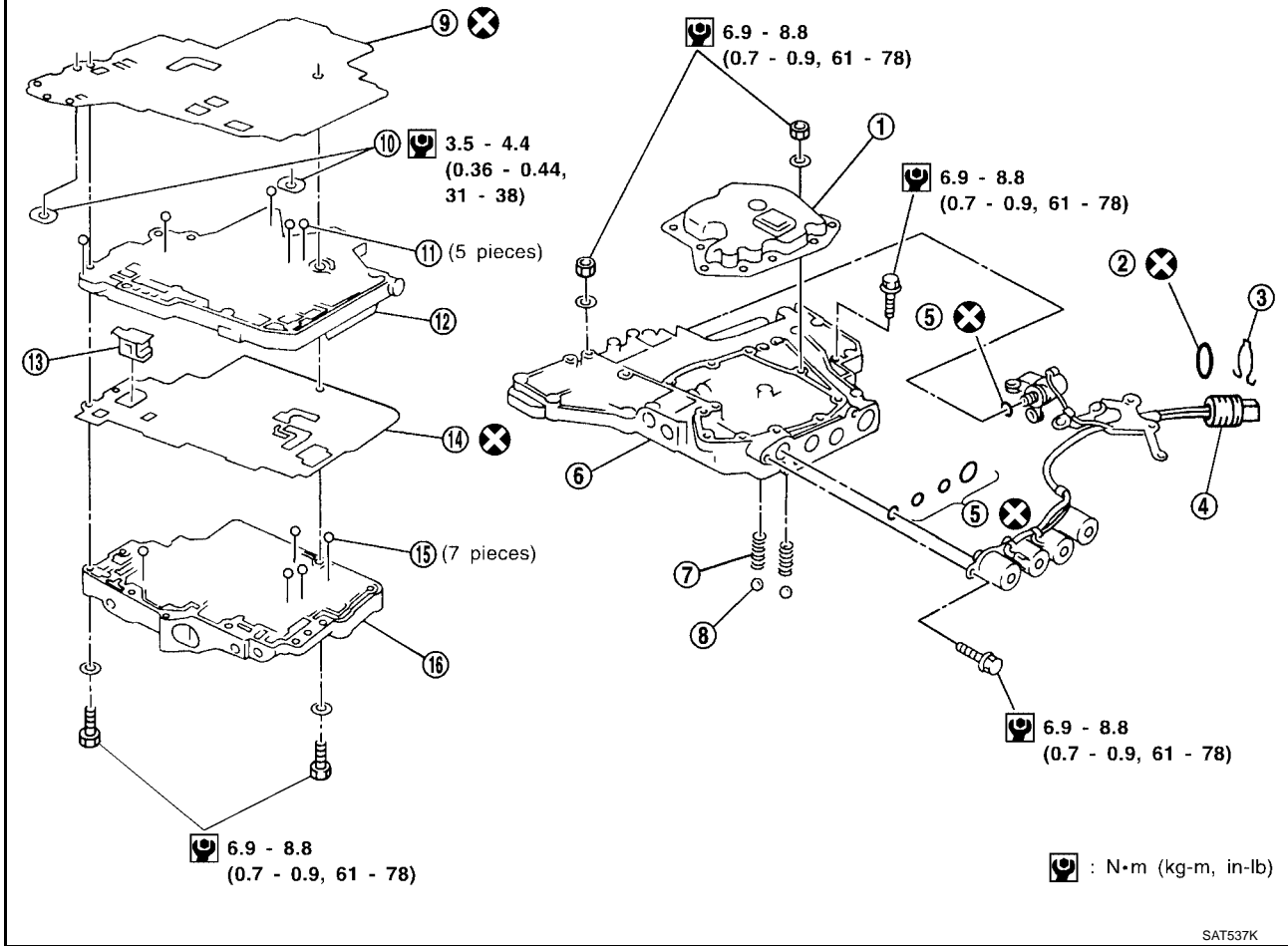

- | | | |
|-----------------------------------|----------------------|------------------------------|
| 1. Oil strainer | 2. O-ring | 3. Snap ring |
| 4. Terminal body | 5. O-rings | 6. Control valve lower body |
| 7. Oil cooler relief valve spring | 8. Check ball | 9. Separating plate |
| 10. Support plate | 11. Steel ball | 12. Control valve inter body |
| 13. Pilot filter | 14. Separating plate | 15. Steel ball |
| 16. Control valve upper body | | |

DISASSEMBLY

Disassemble upper, inter and lower bodies.

REPAIR FOR COMPONENT PARTS

Bolt length, number and location:

Bolt symbol	a	b	c	d	e	f	g
Bolt length "ℓ" mm (in) 	13.5 (0.531)	58.0 (2.283)	40.0 (1.575)	66.0 (2.598)	33.0 (1.299)	78.0 (3.071)	18.0 (0.709)
Number of bolts	6	3	6	11	2	2	1

f: Reamer bolt and nut.

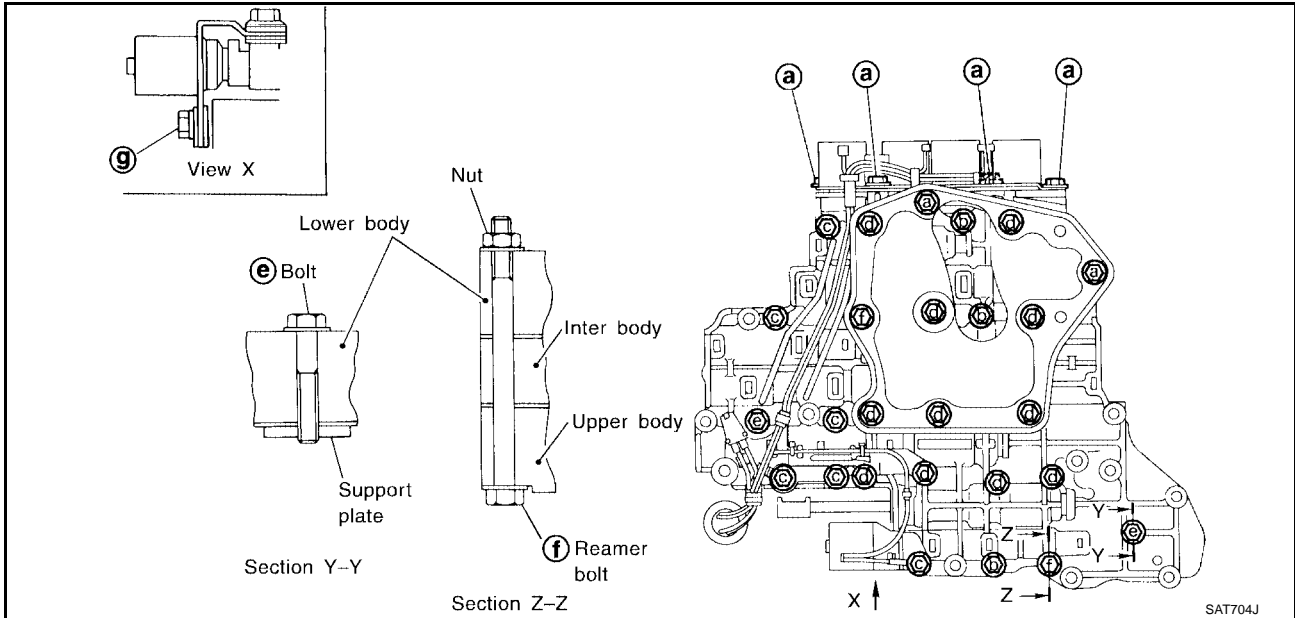

1. Remove bolts **a**, **d** and nut **f** and remove oil strainer from control valve assembly.

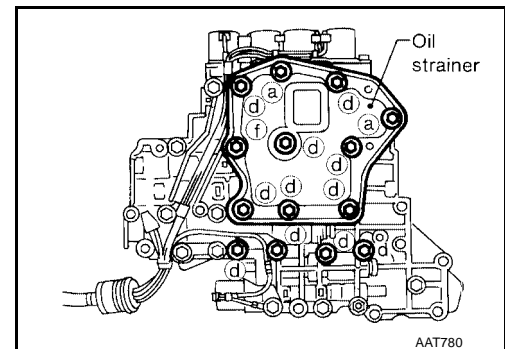

2. Remove solenoid valve assembly and line pressure solenoid valve from control valve assembly.

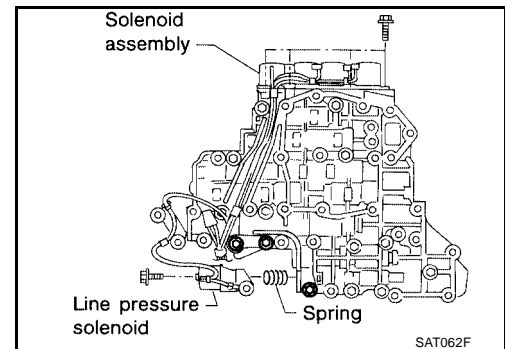

REPAIR FOR COMPONENT PARTS

9. Remove inter body from upper body.

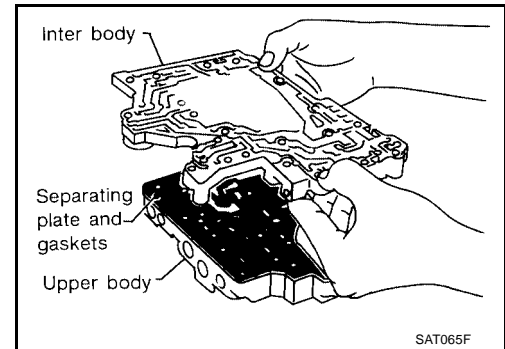

10. Check to see that steel balls are properly positioned in inter body and then remove them.

- Be careful not to lose steel balls.

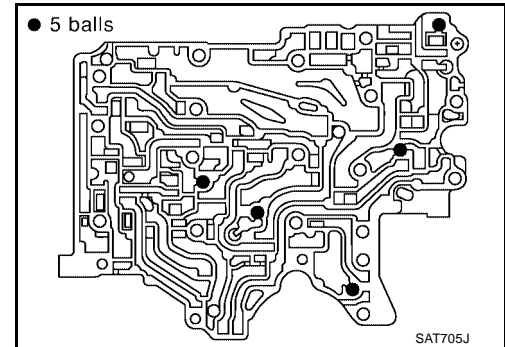

11. Check to see that steel balls are properly positioned in upper body and then remove them.

- Be careful not to lose steel balls.

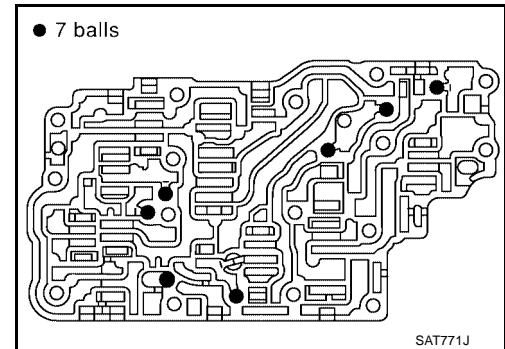

INSPECTION

Lower and Upper Bodies

- Check to see that retainer plates are properly positioned in lower body.

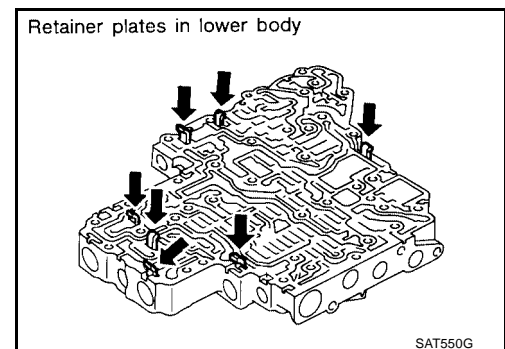

REPAIR FOR COMPONENT PARTS

- Check to see that retainer plates are properly positioned in upper body.
- **Be careful not to lose these parts.**

Retainer plates in upper body

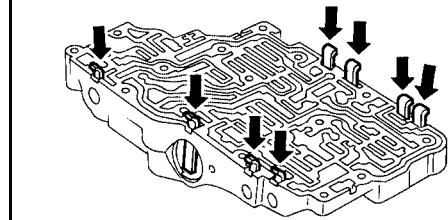

SAT551G

Oil Strainer

- Check wire netting of oil strainer for damage.

Shift Solenoid Valves "A" and "B", Line Pressure Solenoid Valve, Torque Converter Clutch Solenoid Valve and Overrun Clutch Solenoid Valve

- Measure resistance.
- For shift solenoid valve A, refer to [AT-168, "Diagnostic Procedure"](#).
- For shift solenoid valve B, refer to [AT-173, "Diagnostic Procedure"](#).
- For line pressure solenoid valve, refer to [AT-162, "Diagnostic Procedure"](#).
- For torque converter clutch solenoid valve, refer to [AT-149, "Diagnostic Procedure"](#).
- For overrun clutch solenoid valve, refer to [AT-184, "Diagnostic Procedure"](#).

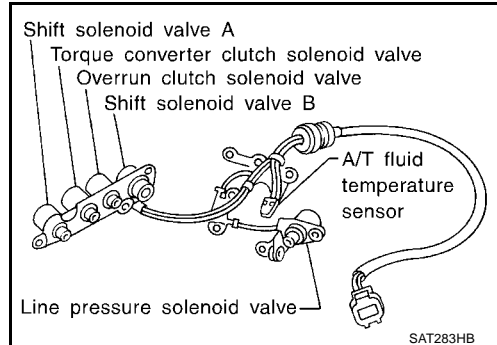

SAT283HB

Oil Cooler Relief Valve Spring

- Check springs for damage or deformation.
- Measure free length and outer diameter.

Inspection standard : Refer to [AT-374, "Control Valves"](#).

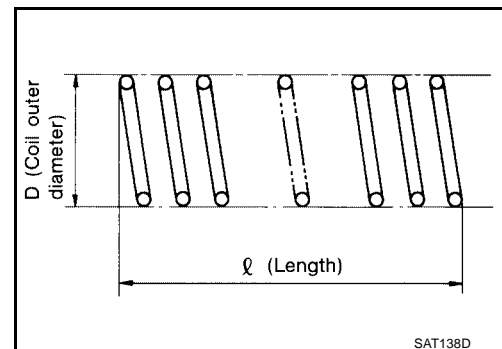

SAT138D

ASSEMBLY

1. Install upper, inter and lower body.
 - a. Place oil circuit of upper body face up. Install steel balls in their proper positions.

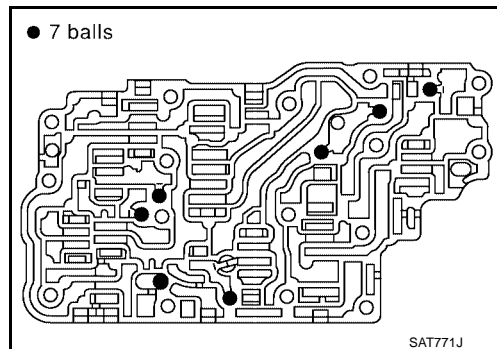

SAT771J

REPAIR FOR COMPONENT PARTS

- b. Install upper separating gasket, upper inter separating gasket and upper separating plate in order shown in illustration.

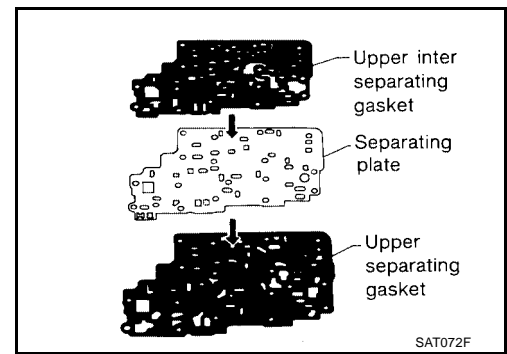

- c. Install reamer bolts **f** from bottom of upper body. Using reamer bolts as guides, install separating plate and gaskets as a set.

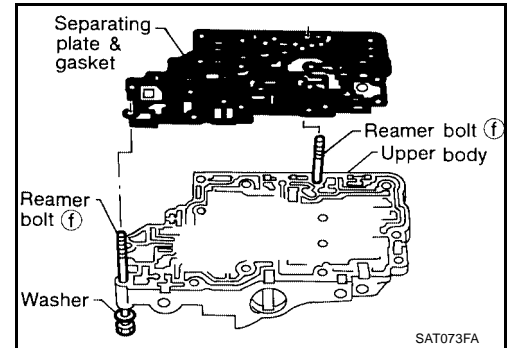

- d. Install pilot filter.

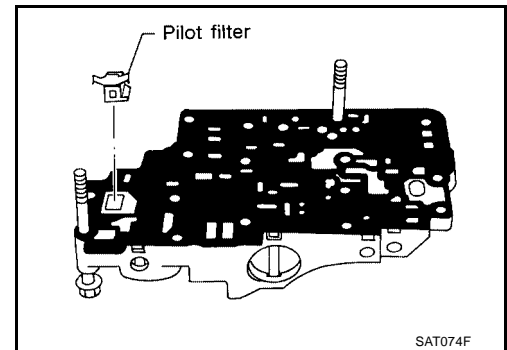

- e. Place lower body as shown in illustration (side of inter body face up). Install steel balls in their proper positions.

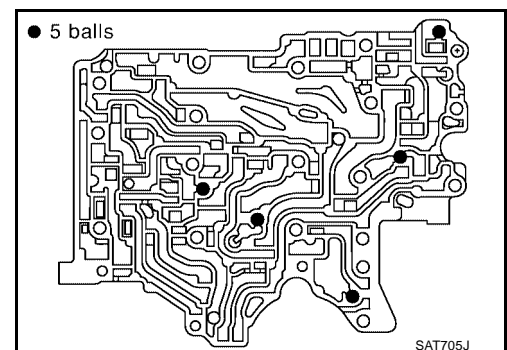

- f. Install inter body on upper body using reamer bolts **f** as guides.
● Be careful not to dislocate or drop steel balls.

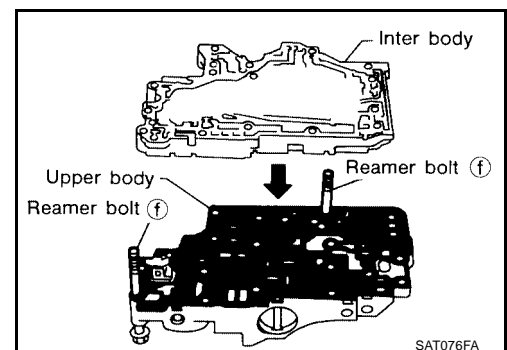

REPAIR FOR COMPONENT PARTS

- g. Install check balls and oil cooler relief valve springs in their proper positions in lower body.

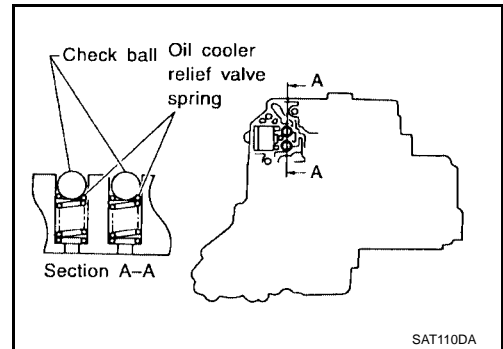

- h. Install lower separating gasket, lower inter separating gasket and lower separating plate in order shown in illustration.

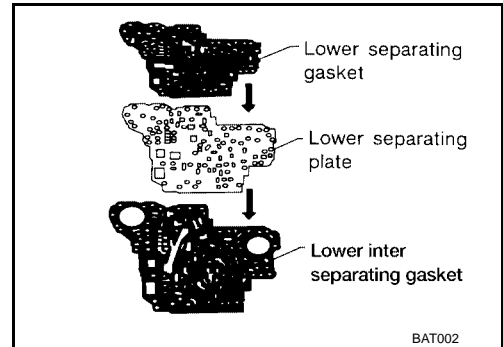

- i. Install bolts **e** from bottom of lower body. Using bolts **e** as guides, install separating plate and gaskets as a set.

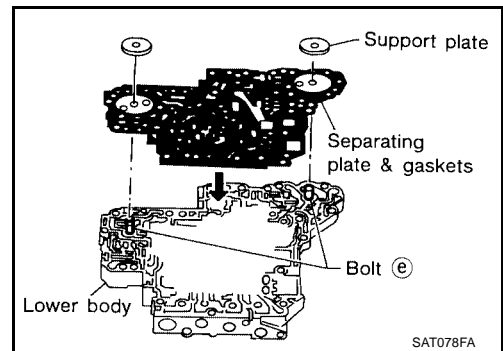

- j. Temporarily install support plates on lower body.
- k. Install lower body on inter body using reamer bolts **f** as guides and tighten reamer bolts **f** slightly.

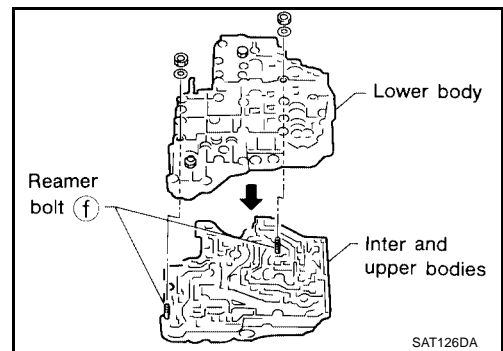

A
B
AT
D
E
F
G
H
I
J
K
L
M

REPAIR FOR COMPONENT PARTS

2. Install O-rings to solenoid valves and terminal body.

- Apply ATF to O-rings.

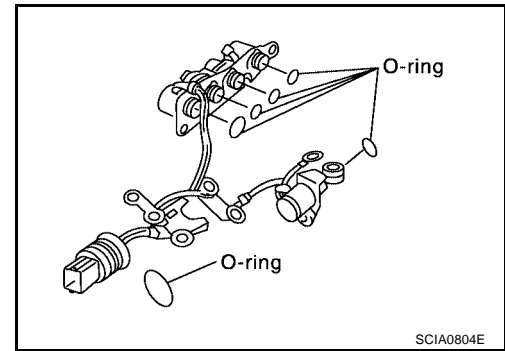

3. Install and tighten bolts.

Bolt length, number and location:

Bolt symbol	a	b	c	d	e	f	g
Bolt length "ℓ" mm (in) ℓ	13.5 (0.53 1)	58.0 (2.28 3)	40.0 (1.57 5)	66.0 (2.59 8)	33.0 (1.29 9)	78.0 (3.07 1)	18.0 (0.70 9)
Number of bolts	6	3	6	11	2	2	1

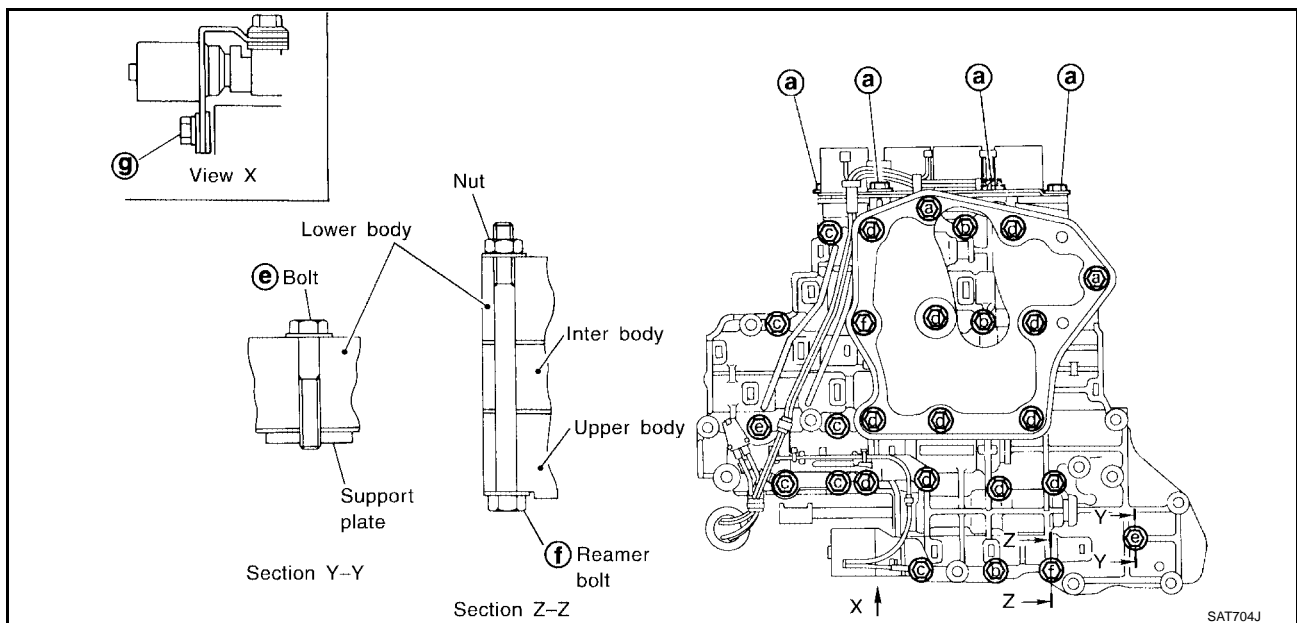

a. Install and tighten bolts **b** to specified torque.

- : 7 - 9 N-m (0.7 - 0.9 kg-m, 61 - 78 in-lb)

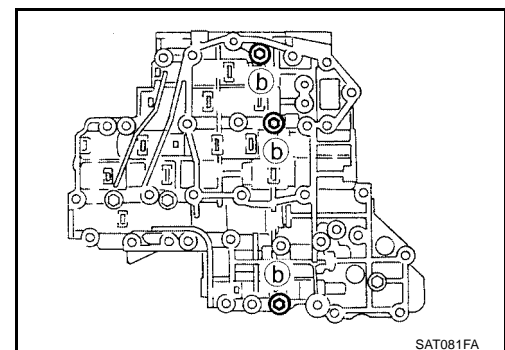

REPAIR FOR COMPONENT PARTS

- b. Install solenoid valve assembly and line pressure solenoid valve to lower body.

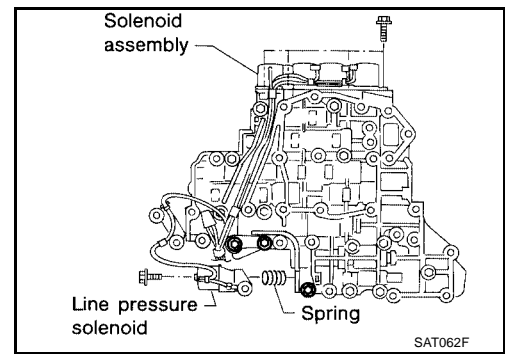

- c. Set oil strainer, then tighten bolts **a** , **c** , **d** and nuts **f** to specified torque.

 : 7 - 9 N-m (0.7 - 0.9 kg-m, 61 - 78 in-lb)

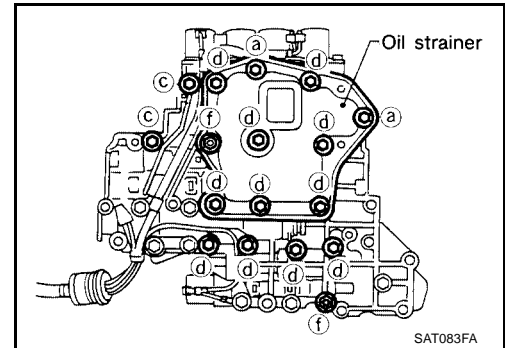

- d. Tighten bolts **e** to specified torque.

 : 3.4 - 4.4 N-m (0.35 - 0.45 kg-m, 30.4 - 39.1 in-lb)

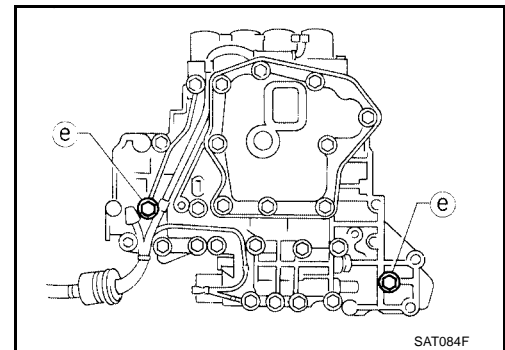

Control Valve Upper Body COMPONENTS

Apply ATF to all components before installation.

ECS006FE

A
B
AT
D
E
F
G
H
I
J
K
L
M

REPAIR FOR COMPONENT PARTS

SEC. 317

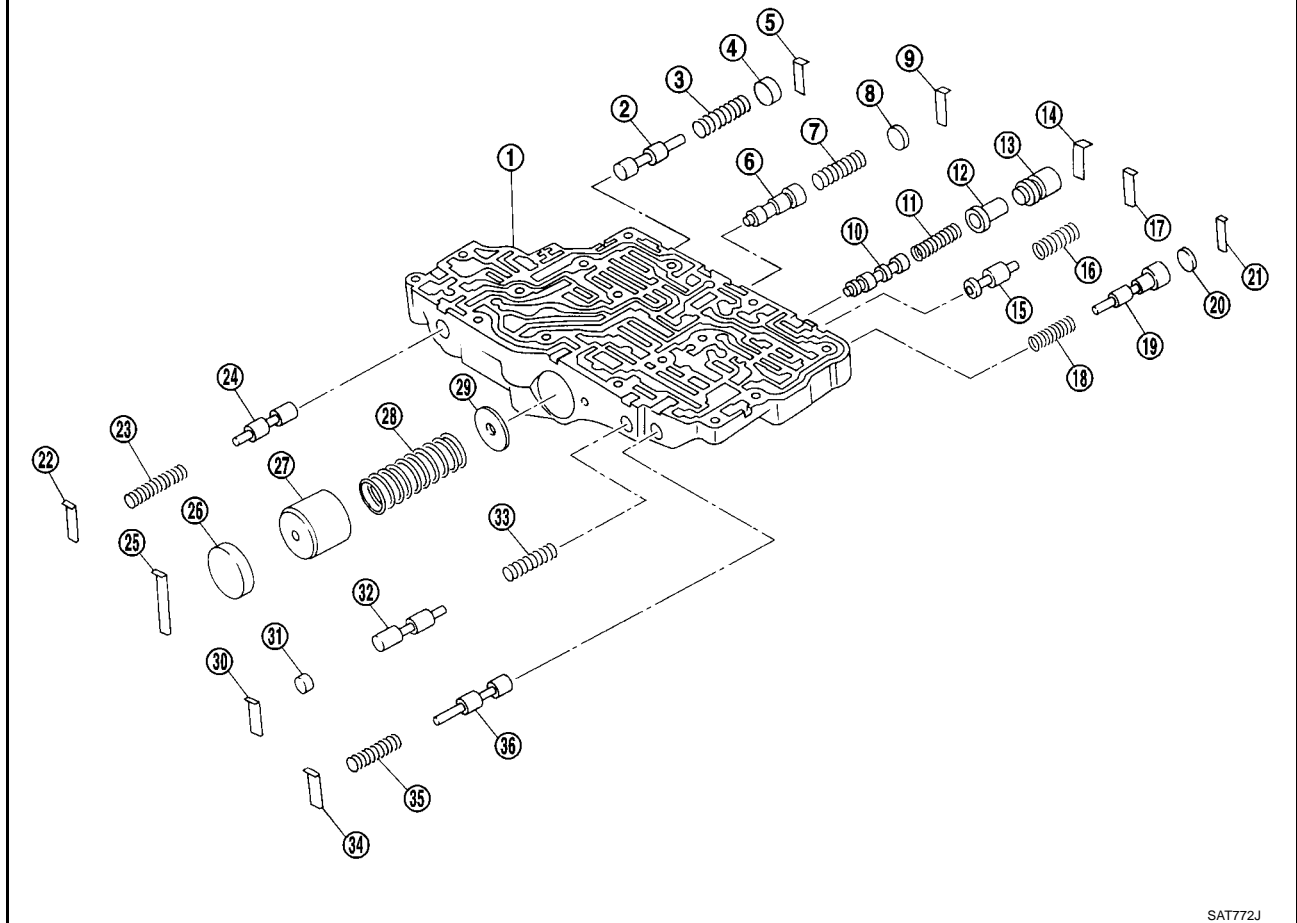

SAT772J

- | | | |
|--|------------------------------------|--|
| 1. Upper body | 2. Cooler check valve | 3. Return spring |
| 4. Plug | 5. Retainer plate | 6. 1-2 accumulator valve |
| 7. Return spring | 8. Plug | 9. Retainer plate |
| 10. Torque converter clutch control valve | 11. Return spring | 12. Torque converter clutch control plug |
| 13. Torque converter clutch control sleeve | 14. Retainer plate | 15. Torque converter relief valve |
| 16. Return spring | 17. Retainer plate | 18. Return spring |
| 19. Overrun clutch reducing valve | 20. Plug | 21. Retainer plate |
| 22. Retainer plate | 23. Return spring | 24. Pilot valve |
| 25. Retainer plate | 26. Plug | 27. 1-2 accumulator piston |
| 28. Return spring | 29. 1-2 accumulator retainer plate | 30. Retainer plate |
| 31. Plug | 32. 1st reducing valve | 33. Return spring |
| 34. Retainer plate | 35. Return spring | 36. 3-2 timing valve |

REPAIR FOR COMPONENT PARTS

DISASSEMBLY

1. Remove valves at retainer plates.
 - Do not use a magnetic pick-up tool.

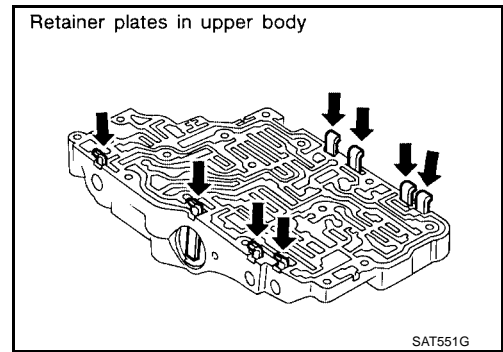

- a. Use a screwdriver to remove retainer plates.

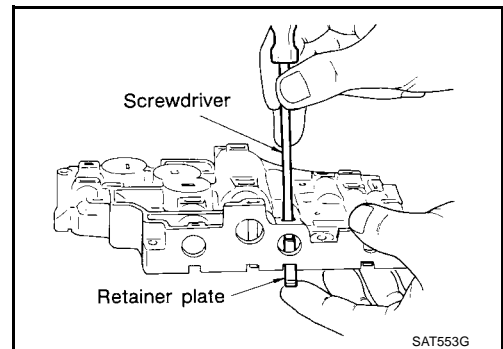

- b. Remove retainer plates while holding spring, plugs or sleeves.
 - Remove plugs slowly to prevent internal parts from jumping out.

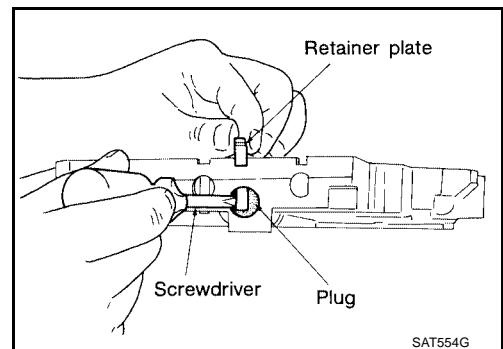

- c. Place mating surface of valve body face down, and remove internal parts.
 - If a valve is hard to remove, place valve body face down and lightly tap it with a soft hammer.
 - Be careful not to drop or damage valves and sleeves.

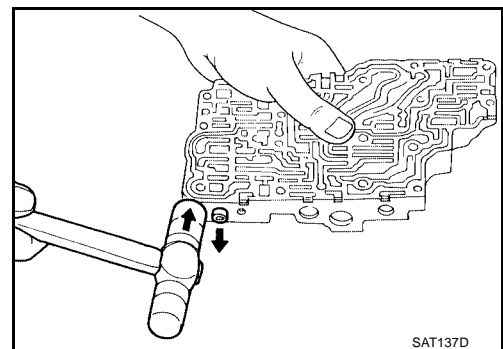

A
B
AT
D
E
F
G
H
I
J
K
L
M

REPAIR FOR COMPONENT PARTS

INSPECTION

Valve Spring

- Measure free length and outer diameter of each valve spring. Also check for damage or deformation.

Inspection standard : Refer to [AT-374, "Control Valves"](#) .

- Replace valve springs if deformed or fatigued.

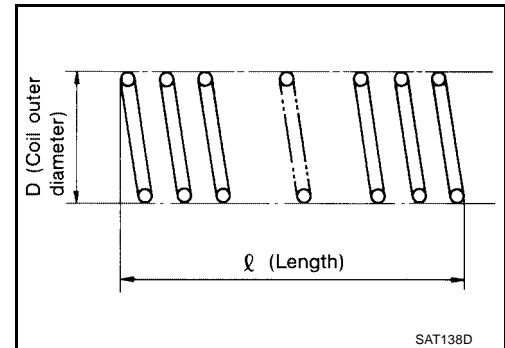

Control Valves

- Check sliding surfaces of valves, sleeves and plugs.

ASSEMBLY

- Lay control valve body down when installing valves. Do not stand the control valve body upright.

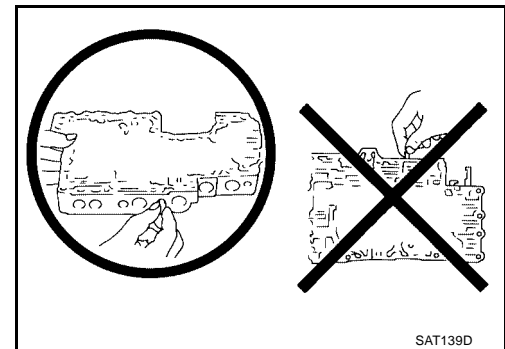

1. Lubricate the control valve body and all valves with ATF. Install control valves by sliding them carefully into their bores.

- Be careful not to scratch or damage valve body.

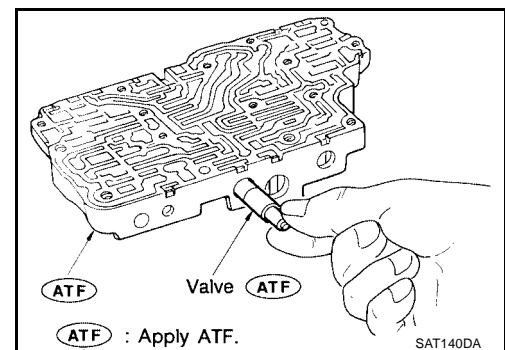

- Wrap a small screwdriver with vinyl tape and use it to insert the valves into their proper positions.

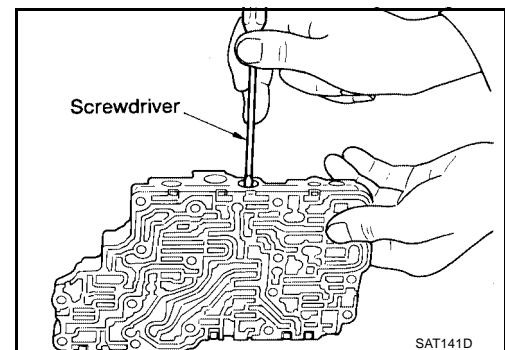

REPAIR FOR COMPONENT PARTS

1-2 Accumulator Valve

- Install 1-2 accumulator valve. Align 1-2 accumulator retainer plate from opposite side of control valve body.
- Install return spring, 1-2 accumulator piston and plug.

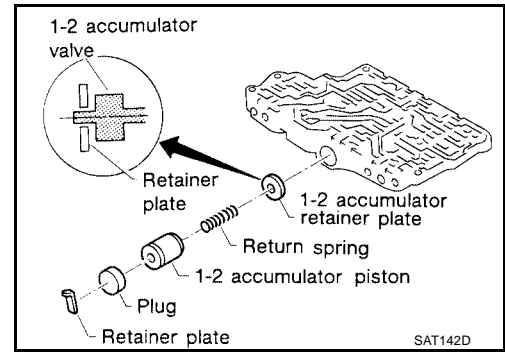

1. Install retainer plates.
 - While pushing plug or return spring, install retainer plate.

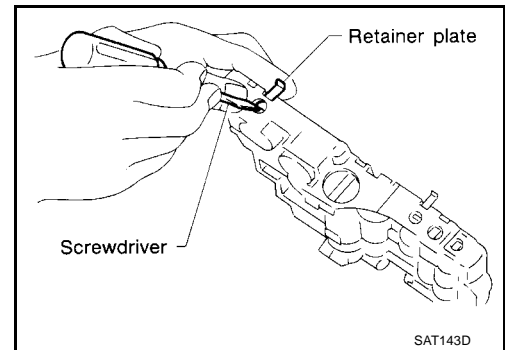

Retainer Plate (Upper Body)

Unit: mm (in)

No.	Name of control valve	Width A	Length B
22	Pilot valve	6.0 (0.236)	21.5 (0.846)
30	1st reducing valve		
34	3-2 timing valve		
17	Torque converter relief valve		38.5 (1.516)
9	1-2 accumulator valve		
25	1-2 accumulator piston valve		24.0 (0.945)
21	Overrun clutch reducing valve		
5	Cooler check valve		28.0 (1.102)
14	Torque converter clutch control valve		

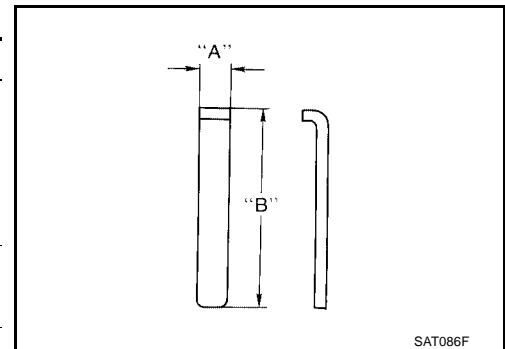

- Install proper retainer plates.
Refer to [AT-307, "COMPONENTS"](#).

Control Valve Lower Body COMPONENTS

ECS006FF

Apply ATF to all components before installation.

REPAIR FOR COMPONENT PARTS

SEC. 317

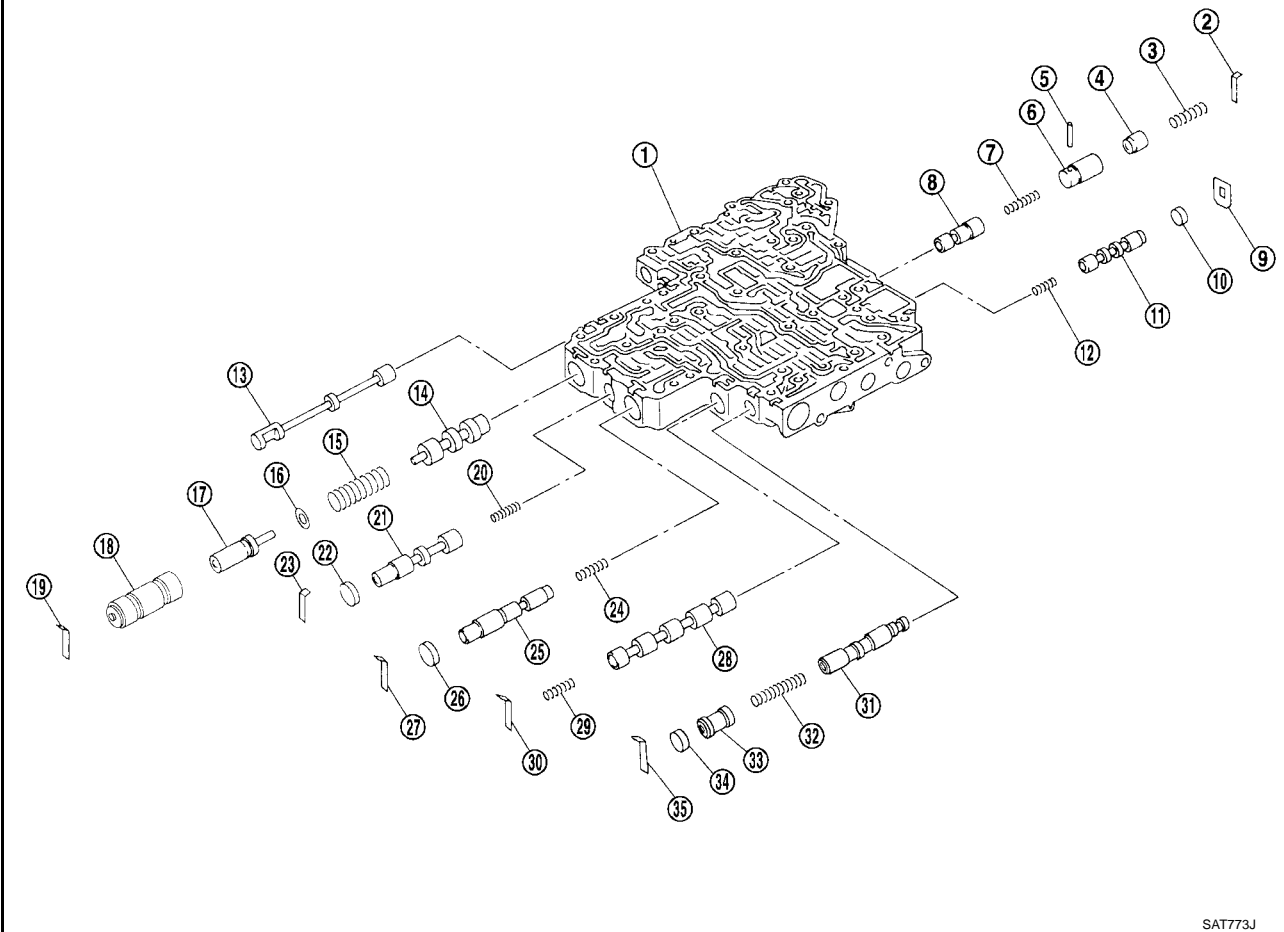

SAT773J

- | | | |
|-------------------------------|------------------------------|----------------------------------|
| 1. Lower body | 2. Retainer plate | 3. Return spring |
| 4. Piston | 5. Parallel pin | 6. Sleeve |
| 7. Return spring | 8. Pressure modifier valve | 9. Retainer plate |
| 10. Plug | 11. Shift valve B | 12. Return spring |
| 13. Manual valve | 14. Pressure regulator valve | 15. Return spring |
| 16. Spring seat | 17. Plug | 18. Sleeve |
| 19. Retainer plate | 20. Return spring | 21. Overrun clutch control valve |
| 22. Plug | 23. Retainer plate | 24. Return spring |
| 25. Accumulator control valve | 26. Plug | 27. Retainer plate |
| 28. Shift valve A | 29. Return spring | 30. Retainer plate |
| 31. Shuttle valve | 32. Return spring | 33. Plug |
| 34. Plug | 35. Retainer plate | |

DISASSEMBLY

- Remove valves at retainer plate.
For removal procedures, refer to [AT-311, "COMPONENTS"](#).

Retainer plates in lower body

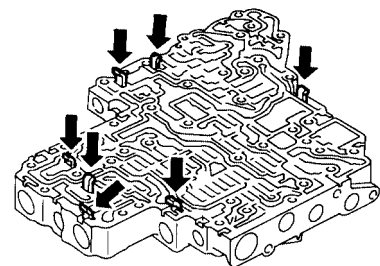

SAT550G

REPAIR FOR COMPONENT PARTS

INSPECTION

Valve Springs

- Check each valve spring for damage or deformation. Also measure free length and outer diameter.

Inspection standard : Refer to [AT-374, "Control Valves"](#) .

- Replace valve springs if deformed or fatigued.

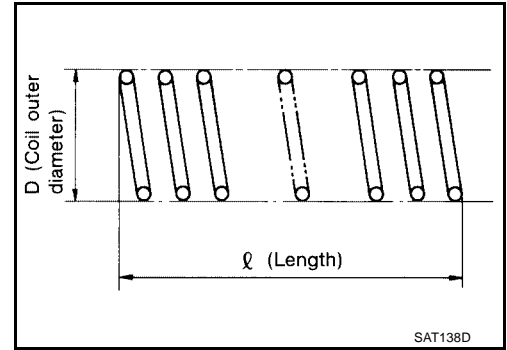

Control Valves

- Check sliding surfaces of control valves, sleeves and plugs for damage.

ASSEMBLY

- Install control valves.
For installation procedures, refer to [AT-311, "COMPONENTS"](#) .

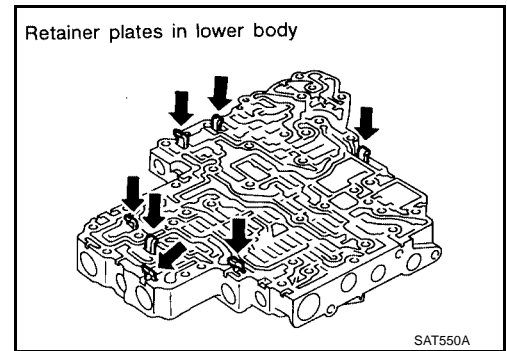

Retainer Plate (Lower Body)

Unit: mm (in)

No.	Name of control valve and plug	Width A	Length B	Type
19	Pressure regulator valve	6.0 (0.236)	28.0 (1.102)	I
27	Accumulator control valve			
30	Shift valve A			
23	Overrun clutch control valve			
2	Pressure modifier valve			
35	Shuttle valve	—	—	II
9	Shift valve B			

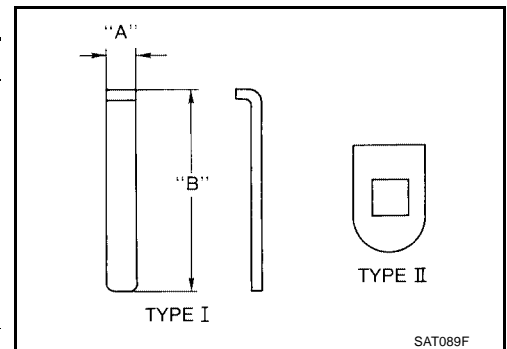

- Install proper retainer plates.
Refer to [AT-311, "COMPONENTS"](#) .

REPAIR FOR COMPONENT PARTS

ECS006FG

Reverse Clutch COMPONENTS

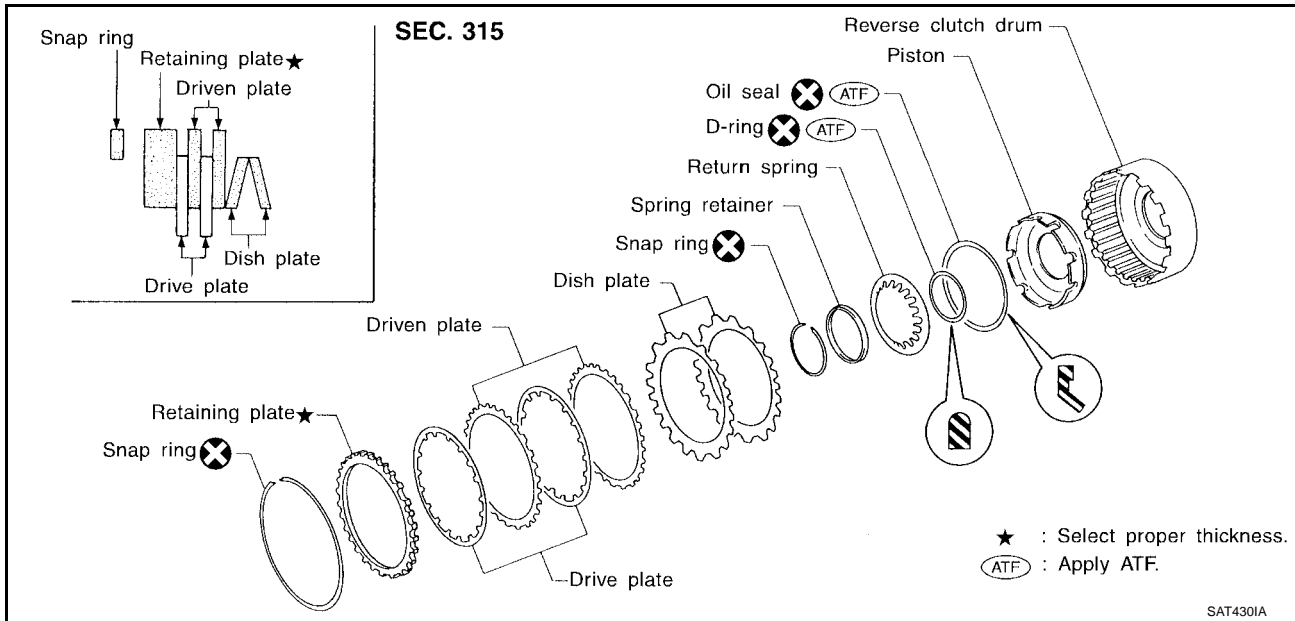

DISASSEMBLY

1. Check operation of reverse clutch
 - a. Install seal ring onto drum support of oil pump cover and install reverse clutch assembly. Apply compressed air to oil hole.
 - b. Check to see that retaining plate moves to snap ring.
 - c. If retaining plate does not contact snap ring:
 - D-ring might be damaged.
 - Oil seal might be damaged.
 - Fluid might be leaking past piston check ball.
2. Remove snap ring.
3. Remove drive plates, driven plates, retaining plate, and dish plates.
4. Set Tool on spring retainer and remove snap ring from reverse clutch drum while compressing return springs.
 - **Set Tool directly over springs.**
 - **Do not expand snap ring excessively.**
5. Remove spring retainer and return springs.

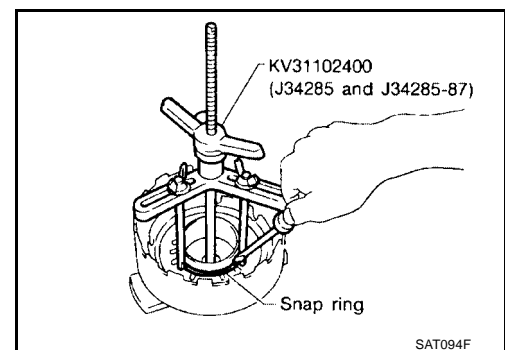
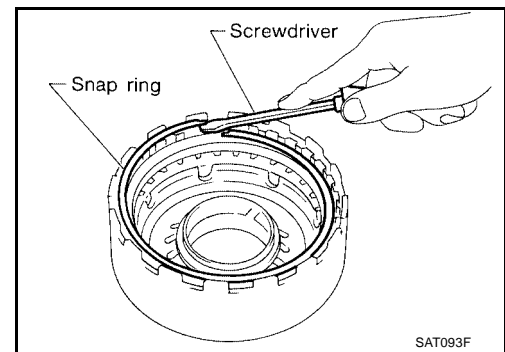
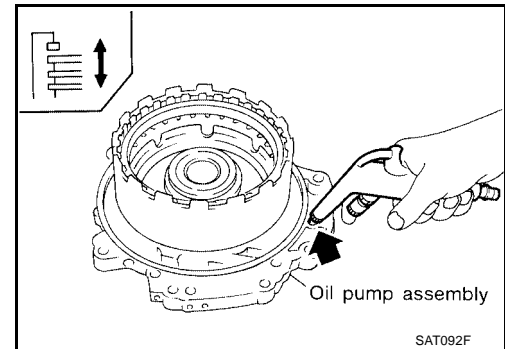

REPAIR FOR COMPONENT PARTS

- Remove piston from reverse clutch drum by turning it.
- Remove D-ring and oil seal from piston.

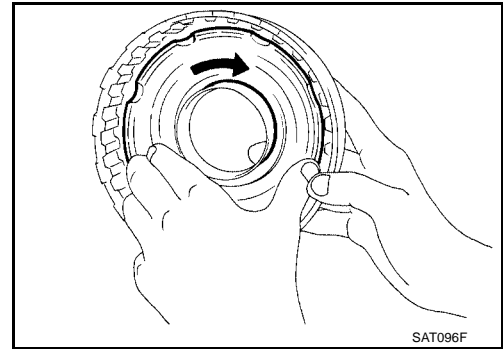

INSPECTION

Reverse Clutch Snap Ring, Spring Retainer and Return Springs

- Check for deformation, fatigue or damage. If necessary, replace.

Reverse Clutch Drive Plates

- Check facing for burns, cracks or damage.
- Measure thickness of facing.

Thickness of drive plate:

Standard value : 1.6 mm (0.063 in)

Wear limit : 1.4 mm (0.055 in)

- If not within wear limit, replace.

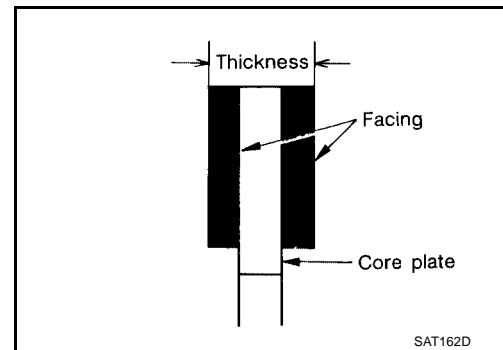

Reverse Clutch Dish Plates

- Check for deformation or damage.
- Measure thickness of dish plate.

Thickness of dish plate : 3.08 mm (0.1213 in)

- If deformed or fatigued, replace.

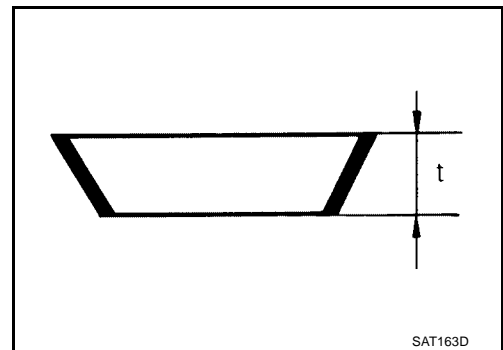

Reverse Clutch Piston

- Make sure that check balls are not fixed.
- Apply compressed air to check ball oil hole opposite the return spring. Make sure there is no air leakage.
- Apply compressed air to oil hole on return spring side to make sure that air leaks past ball.

ASSEMBLY

- Install D-ring and oil seal on piston.
 - Take care with the direction of oil seal.
 - Apply ATF to both parts.

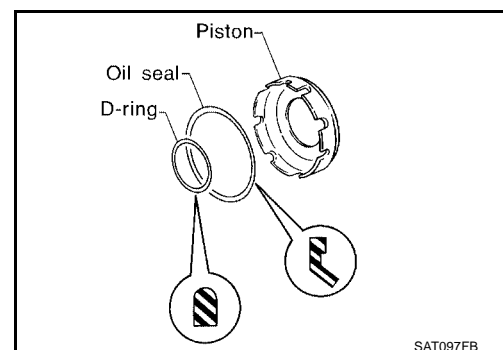

A
B
AT
D
E
F
G
H
I
J
K
L
M

REPAIR FOR COMPONENT PARTS

2. Install piston assembly by turning it slowly.
 - **Apply ATF to inner surface of drum.**

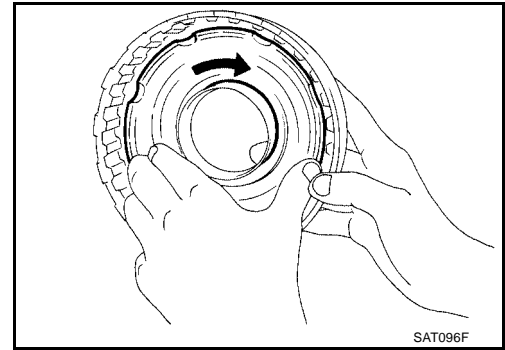

3. Install return springs and spring retainer on piston.

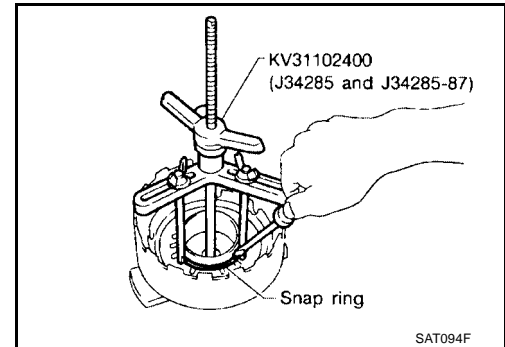

4. Set Tool on spring retainer and install snap ring while compressing return springs.
 - **Set Tool directly over return springs.**
5. Install drive plates, driven plates, retaining plate and dish plates.
 - **Take care with order of plates.**
6. Install snap ring.

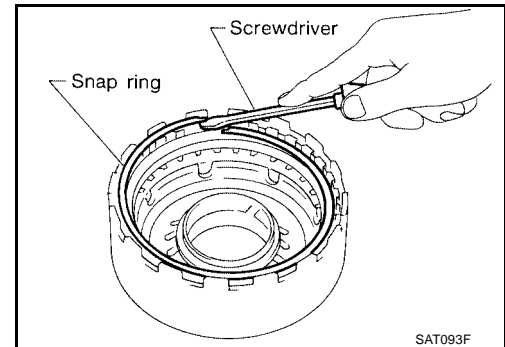

7. Measure clearance between retaining plate and snap ring. If not within allowable limit, select proper retaining plate.

Specified clearance

Standard : 0.5 - 0.8 mm
(0.020 - 0.031 in)

Allowable limit : 1.2 mm (0.047 in)

Retaining plate : Refer to [AT-376](#),
"REVERSE CLUTCH" .

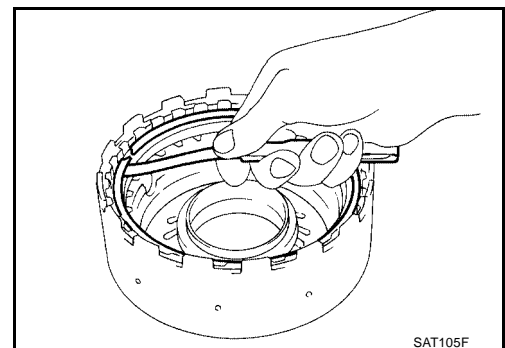

REPAIR FOR COMPONENT PARTS

8. Check operation of reverse clutch.

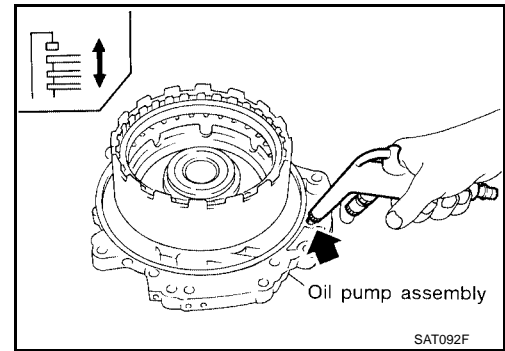

High Clutch COMPONENTS

ECS006FH

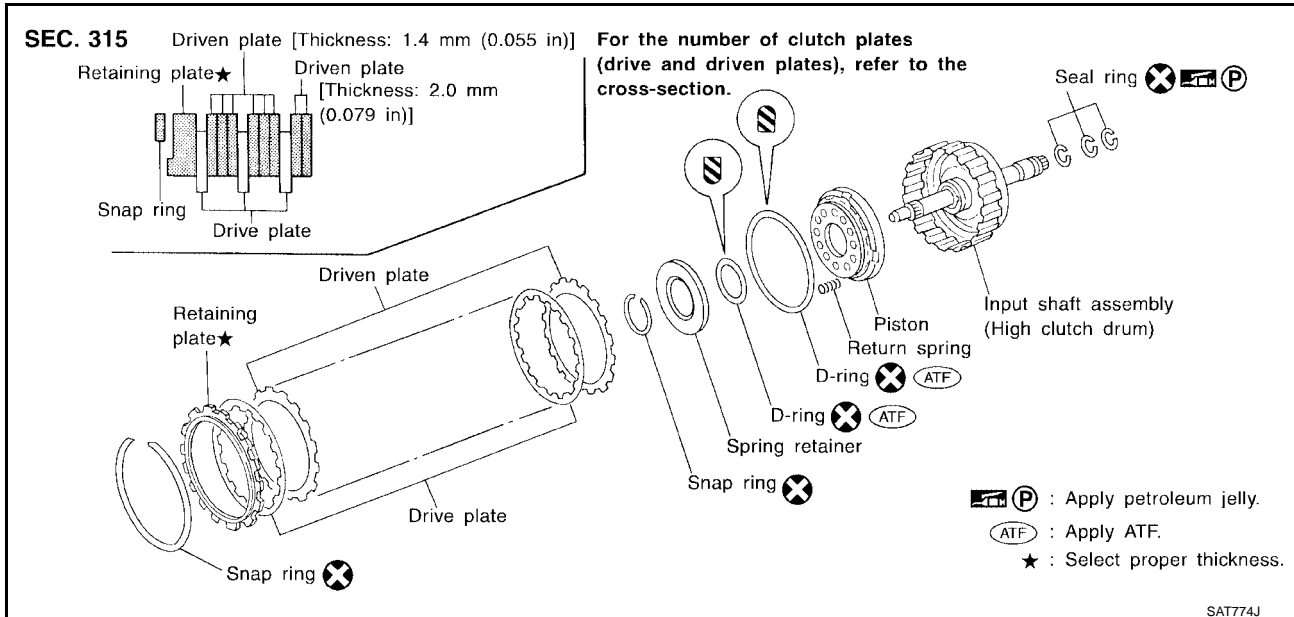

DISASSEMBLY

1. Check operation of high clutch.
 - a. Apply compressed air to oil hole of input shaft with nylon cloth.
 - Stop up hole on opposite side of input shaft with nylon cloth.
 - b. Check to see that retaining plate moves to snap ring.
 - c. If retaining plate does not contact snap ring:
 - D-ring might be damaged.
 - Oil seal might be damaged.
 - Fluid might be leaking past piston check ball.
2. Remove seal rings from input shaft.
 - Always replace when removed.

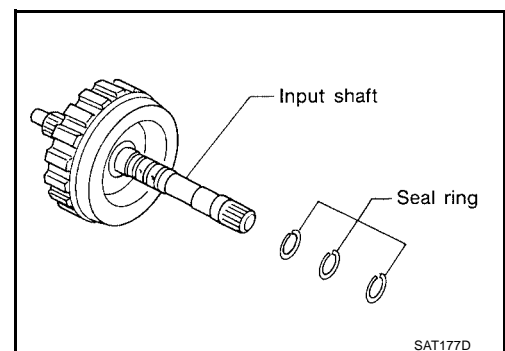
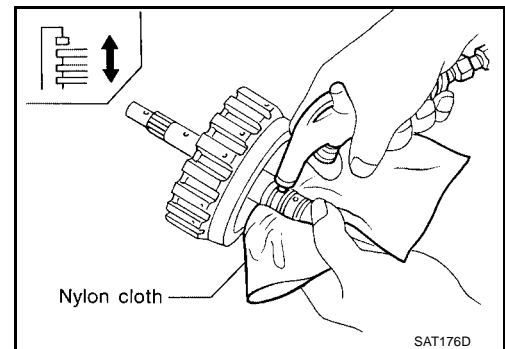

REPAIR FOR COMPONENT PARTS

3. Remove snap ring.
4. Remove drive plates, driven plates and retaining plate.

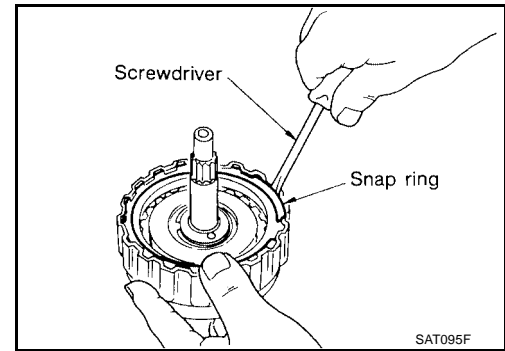

5. Set Tool on spring retainer and remove snap ring from high clutch drum while compressing return springs.
 - **Set Tool directly over springs.**
 - **Do not expand snap ring excessively.**
6. Remove spring retainer and return springs.

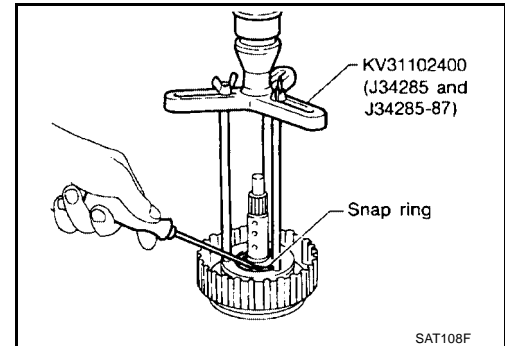

7. Remove piston from high clutch drum by turning it.

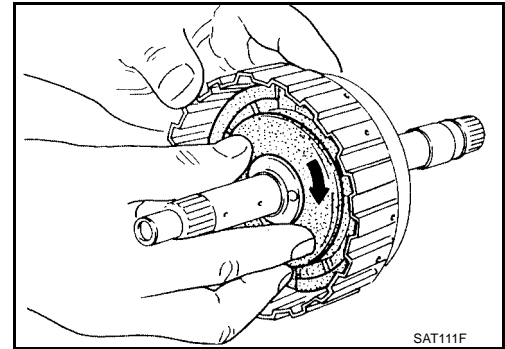

8. Remove D-rings from piston.

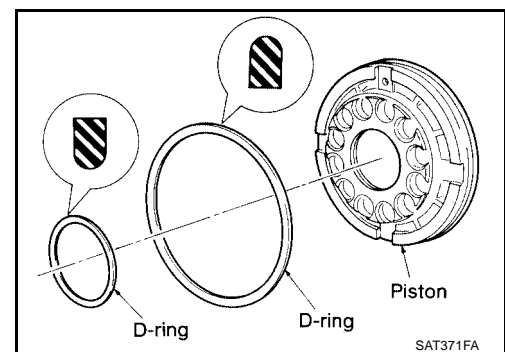

INSPECTION

High Clutch Snap Ring, Spring Retainer and Return Springs

- Check for deformation, fatigue or damage. If necessary, replace.
- **When replacing spring retainer and return springs, replace them as a set.**

REPAIR FOR COMPONENT PARTS

High Clutch Drive Plates

- Check facing for burns, cracks or damage.
- Measure thickness of facing.

Thickness of drive plate:

Standard value : 1.6 mm (0.063 in)

Wear limit : 1.4 mm (0.055 in)

- If not within wear limit, replace.

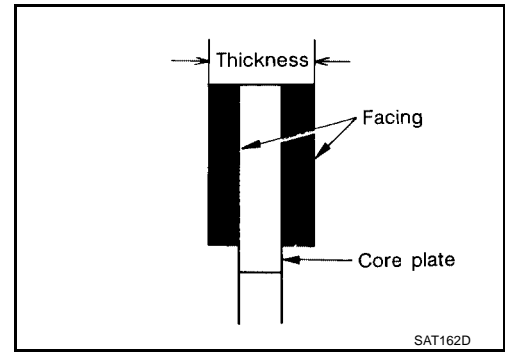

High Clutch Piston

- Make sure that check balls are not fixed.
- Apply compressed air to check ball oil hole opposite the return spring. Make sure there is no air leakage.
- Apply compressed air to oil hole on return spring side to make sure that air leaks past ball.

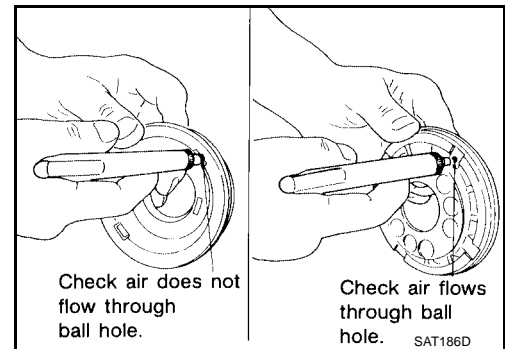

Seal Ring Clearance

- Install new seal rings onto input shaft.
- Measure clearance between seal ring and ring groove.

Standard clearance : 0.08 - 0.23 mm
(0.0031 - 0.0091 in)

Allowable limit : 0.23 mm (0.0091 in)

- If not within allowable limit, replace input shaft assembly.

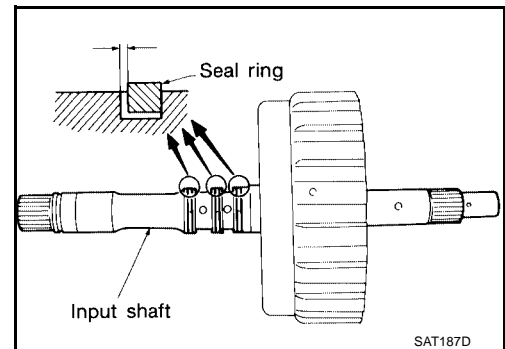

ASSEMBLY

1. Install D-rings on piston.
 - Apply ATF to both parts.

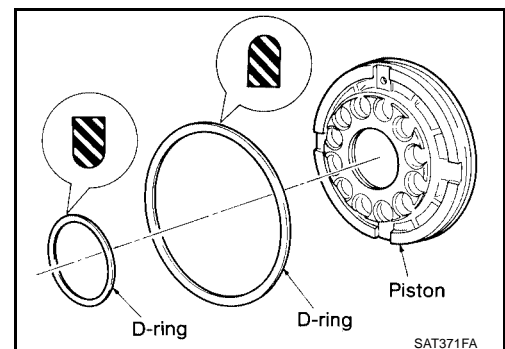

REPAIR FOR COMPONENT PARTS

2. Install piston assembly by turning it slowly.

- **Apply ATF to inner surface of drum.**

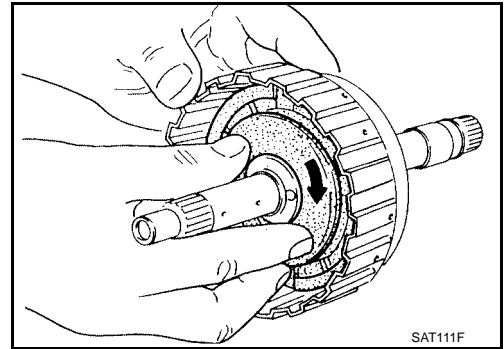

3. Install return springs and spring retainer on piston.

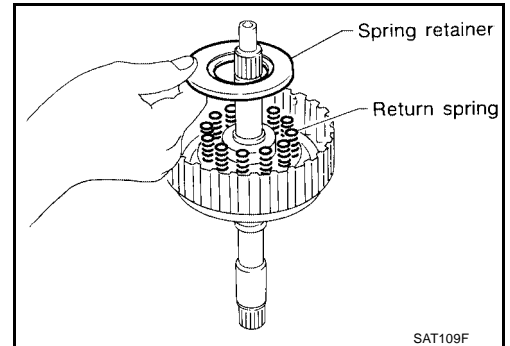

4. Set Tool on spring retainer and install snap ring while compressing return springs.

- **Set Tool directly over return springs.**

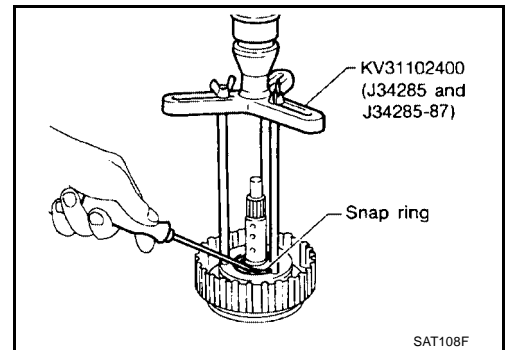

- **Do not align snap ring gap with spring retainer stopper.**

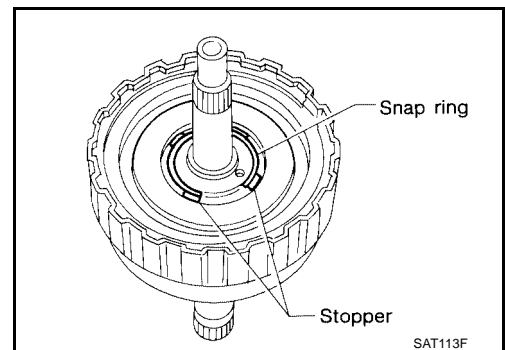

5. Install drive plates, driven plates and retaining plate.

- **Take care with the order and direction of plates.**

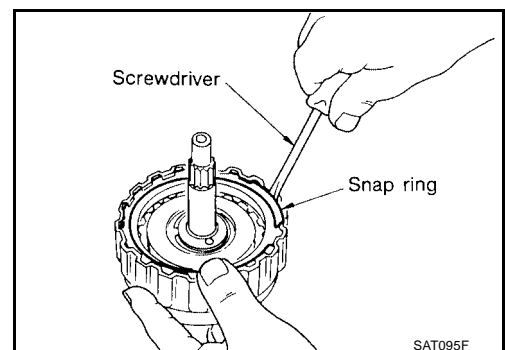

REPAIR FOR COMPONENT PARTS

- Install snap ring.
- Measure clearance between retaining plate and snap ring. If not within allowable limit, select proper retaining plate.

Specified clearance

Standard : 1.8 - 2.2 mm (0.071 - 0.087 in)

Allowable limit : 2.8 mm (0.110 in)

Retaining plate

: Refer to [AT-376, "HIGH CLUTCH — QR25DE MODEL"](#)

.

: Refer to [AT-376, "HIGH CLUTCH — VQ35DE MODEL"](#)

.

- Check operation of high clutch.

- Install seal rings to input shaft.

- Apply petroleum jelly to seal rings.
- Always replace when removed.

- Roll paper around seal rings to prevent seal rings from spreading.

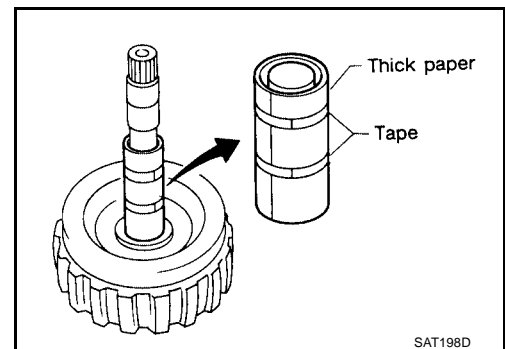
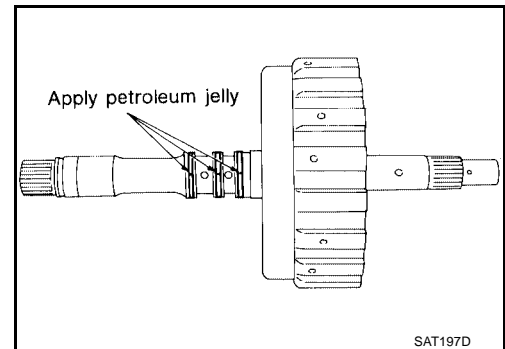
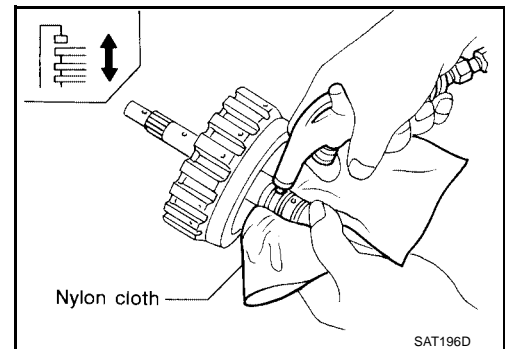
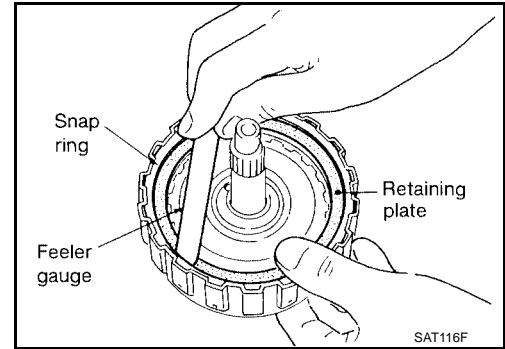

REPAIR FOR COMPONENT PARTS

EC5006F1

Forward and Overrun Clutches COMPONENTS

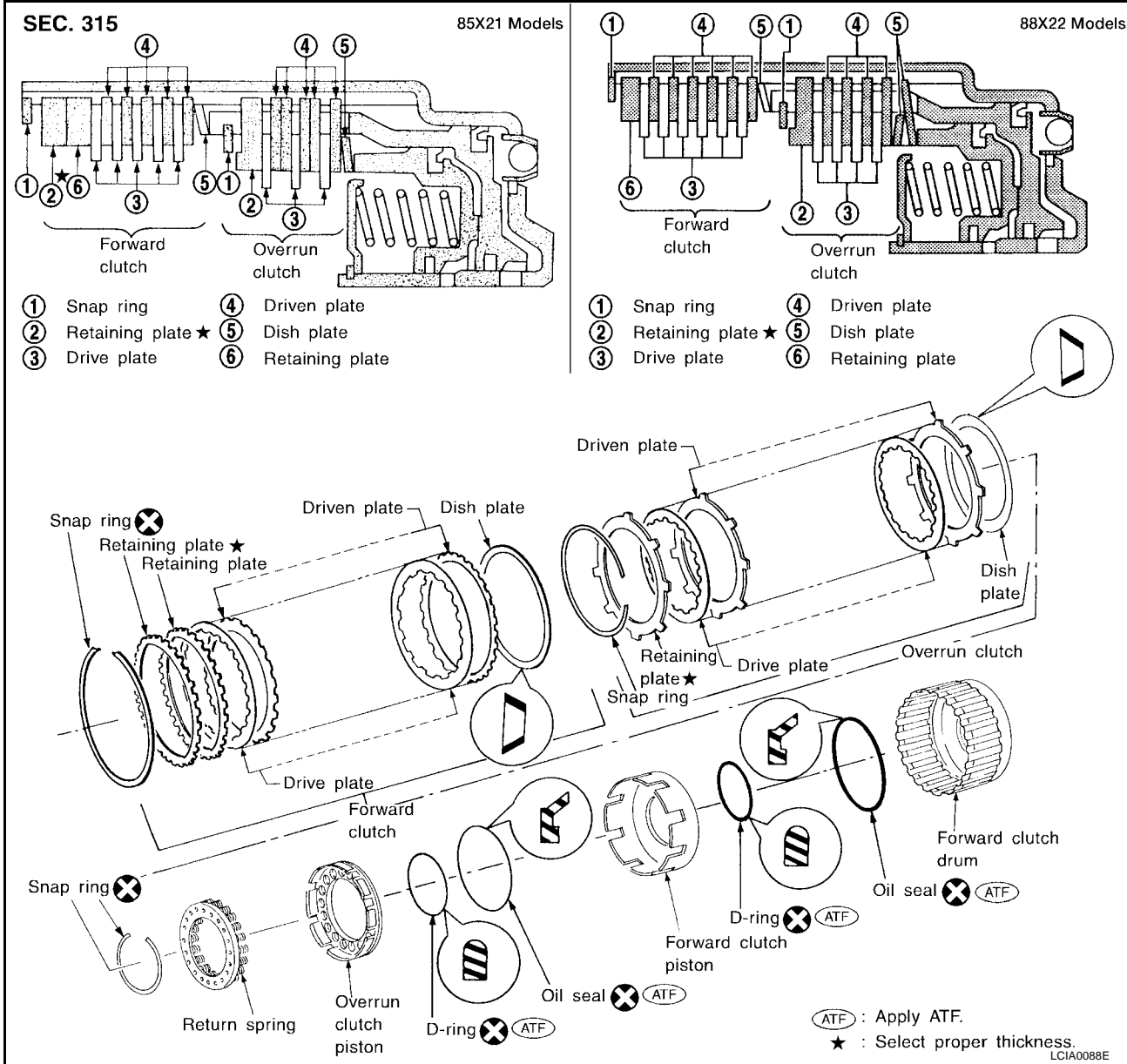

DISASSEMBLY

1. Check operation of forward clutch and overrun clutch.
 - a. Install bearing retainer on forward clutch drum.
 - b. Apply compressed air to oil hole of forward clutch drum.
 - c. Check to see that retaining plate moves to snap ring.
 - d. If retaining plate does not contact snap ring:
 - D-ring might be damaged.
 - Oil seal might be damaged.
 - Fluid might be leaking past piston check ball.

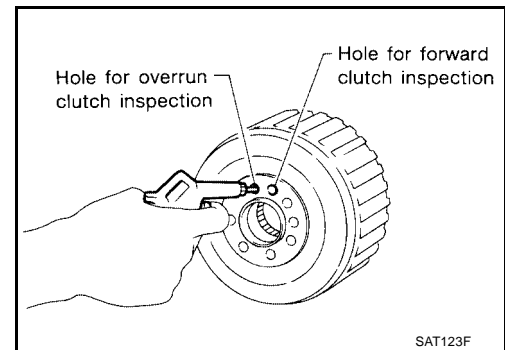

REPAIR FOR COMPONENT PARTS

2. Remove snap ring for forward clutch.
3. Remove drive plates, driven plates, retaining plate and dish plate for forward clutch.

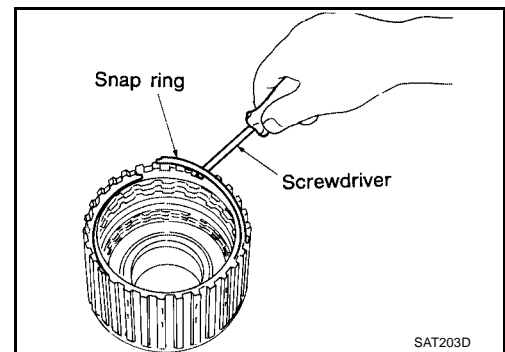

4. Remove snap ring for overrun clutch.
5. Remove drive plates, driven plates, retaining plate and dish plate for overrun clutch.

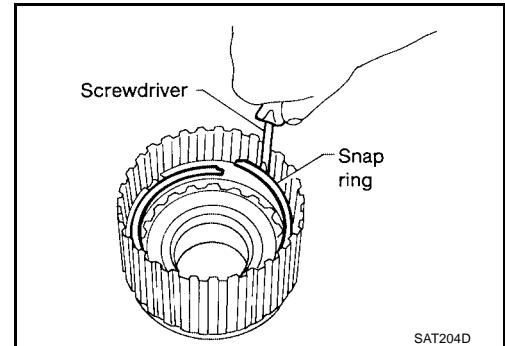

6. Set Tool on spring retainer and remove snap ring from forward clutch drum while compressing return springs.
 - Set Tool directly over return springs.
 - Do not expand snap ring excessively.
7. Remove spring retainer and return springs.
 - Do not remove return springs from spring retainer.

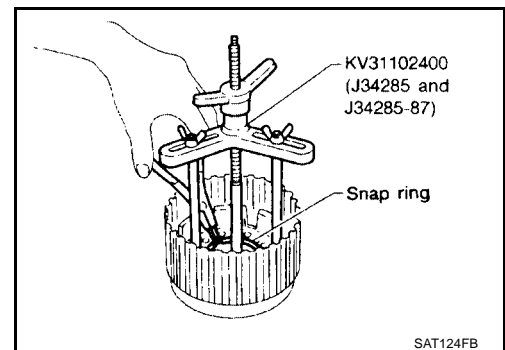

8. Remove forward clutch piston with overrun clutch piston from forward clutch drum by turning it.

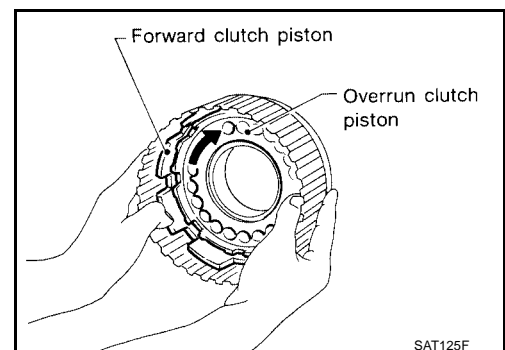

9. Remove overrun clutch piston from forward clutch piston by turning it.

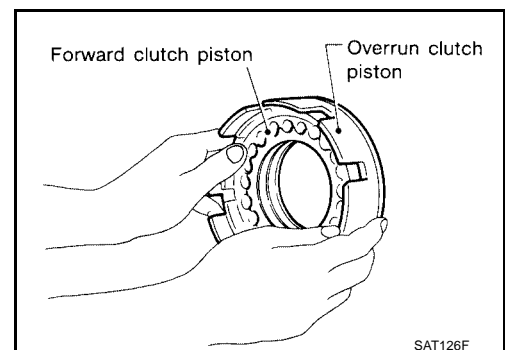

A
B
AT
D
E
F
G
H
I
J
K
L
M

REPAIR FOR COMPONENT PARTS

10. Remove D-rings and oil seals from forward clutch piston and overrun clutch piston.

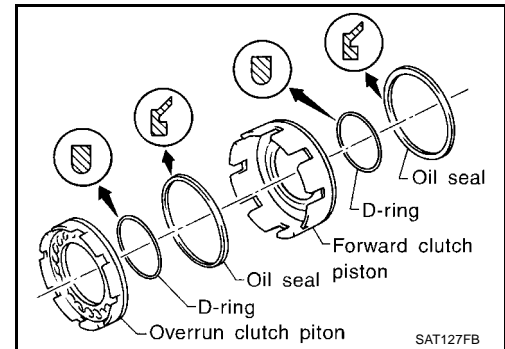

INSPECTION

Snap Rings, Spring Retainer and Return Springs

- Check for deformation, fatigue or damage.
- Replace if necessary.
- **When replacing spring retainer and return springs, replace them as a set.**

Forward Clutch and Overrun Clutch Drive Plates

- Check facing for burns, cracks or damage.
- Measure thickness of facing.

Thickness of drive plate:

Forward clutch

Standard value : 1.6 mm (0.063 in)

Wear limit : 1.4 mm (0.055 in)

Overrun clutch

Standard value : 1.6 mm (0.063 in)

Wear limit : 1.4 mm (0.055 in)

- If not within wear limit, replace.

Forward Clutch and Overrun Clutch Dish Plates

- Check for deformation or damage.
- Measure thickness of dish plate.

Thickness of dish plate

Forward clutch : 2.7 mm (0.106 in)

Overrun clutch : 2.7 mm (0.106 in)

- If deformed or fatigued, replace.

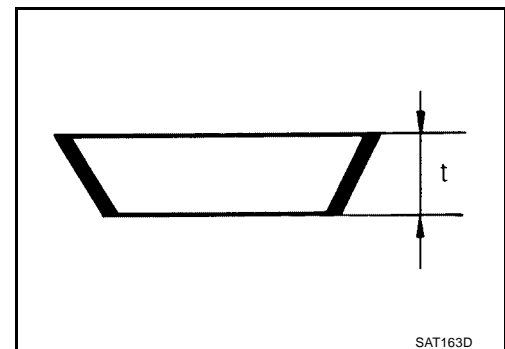
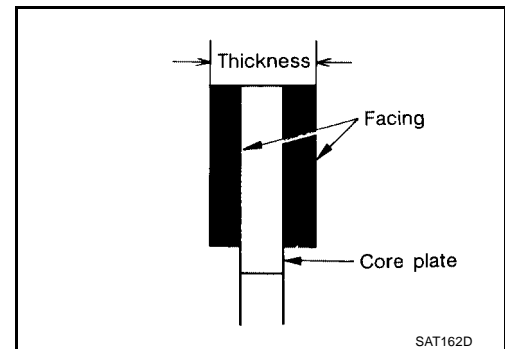

Forward Clutch Drum

- Make sure that check balls are not fixed.
- Apply compressed air to check ball oil hole from outside of forward clutch drum. Make sure air leaks past ball.
- Apply compressed air to oil hole from inside of forward clutch drum. Make sure there is no air leakage.

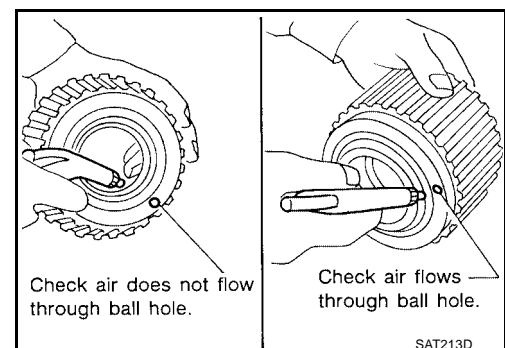

REPAIR FOR COMPONENT PARTS

Overrun Clutch Piston

- Make sure that check balls are not fixed.
- Apply compressed air to check ball oil hole opposite the return spring. Make sure there is no air leakage.
- Apply compressed air to oil hole on return spring side. Make sure that air leaks past ball.

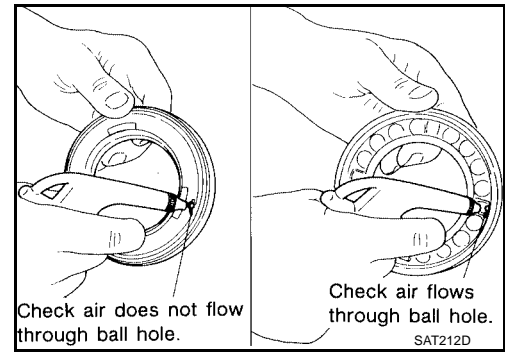

ASSEMBLY

1. Install D-rings and oil seals on forward clutch piston and overrun clutch piston.
 - Take care with direction of oil seal.
 - Apply ATF to both parts.

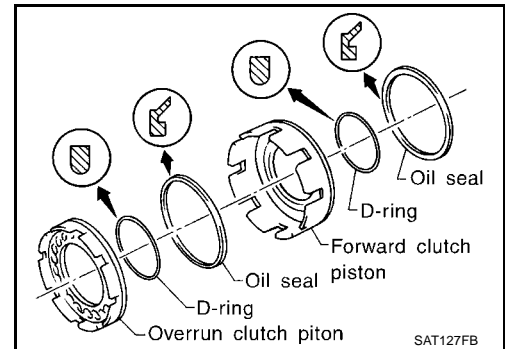

2. Install overrun clutch piston assembly on forward clutch piston by turning it slowly.
 - Apply ATF to inner surface of forward clutch piston.

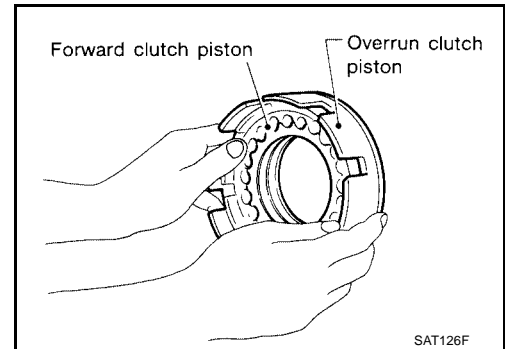

3. Install forward clutch piston assembly on forward clutch drum by turning it slowly.
 - Apply ATF to inner surface of drum.

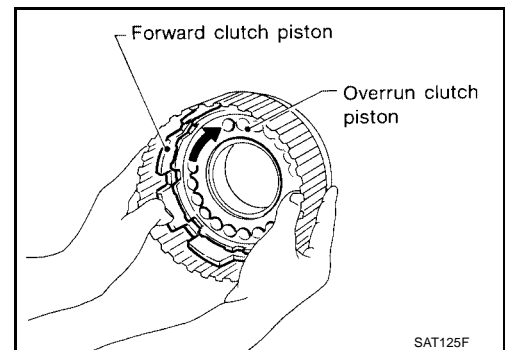

REPAIR FOR COMPONENT PARTS

4. Install return spring on overrun clutch piston.

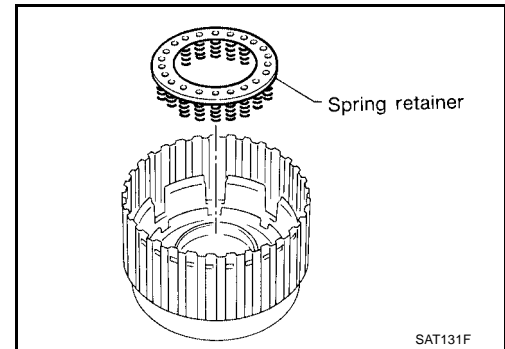

- Align the mark on spring retainer with check ball in overrun clutch piston.

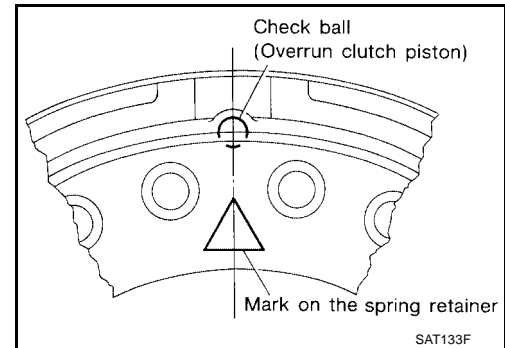

5. Set Tool on spring retainer and install snap ring while compressing return springs.

- **Set Tool directly over return springs.**

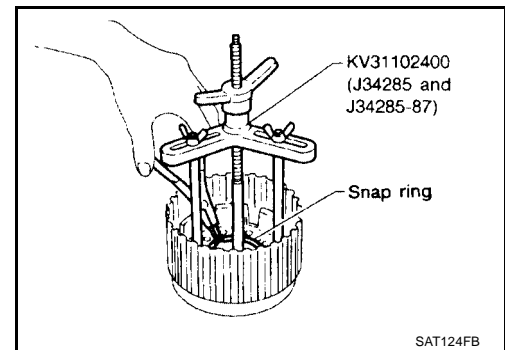

- **Do not align snap ring gap with spring retainer stopper.**

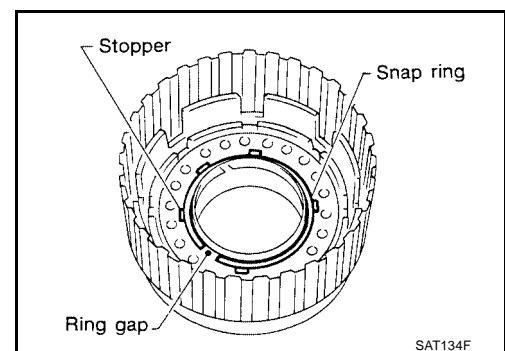

6. Install drive plates, driven plates, retaining plate and dish plate for overrun clutch.

- **Take care with order of plates.**

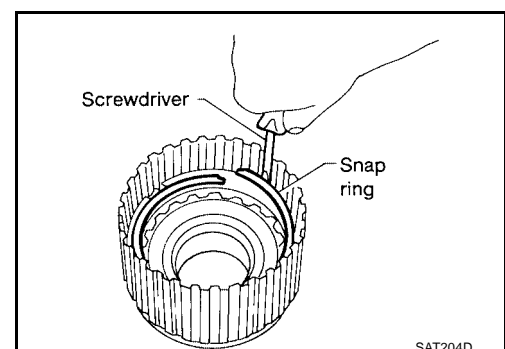

REPAIR FOR COMPONENT PARTS

7. Install snap ring for overrun clutch.
8. Measure clearance between overrun clutch retaining plate and snap ring.
If not within allowable limit, select proper retaining plate.

Specified clearance

Standard : 0.7 - 1.1 mm (0.028 - 0.043 in)

Allowable limit : 1.7 mm (0.067 in)

Overrun clutch retaining plate : Refer to [AT-377, "OVERRUN CLUTCH"](#) .

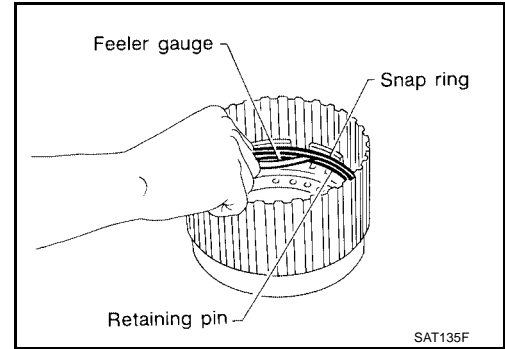

9. Install drive plates, driven plates, retaining plate and dish plate for forward clutch.
 - **Take care with order of plates.**
10. Install snap ring for forward clutch.

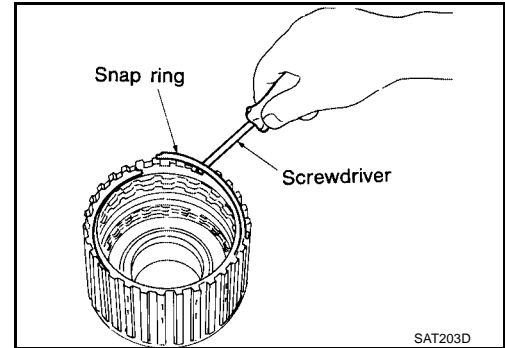

11. Measure clearance between forward clutch retaining plate and snap ring.
If not within allowable limit, select proper retaining plate.

Specified clearance

Standard : 0.45 - 0.85 mm
(0.0177 - 0.0335 in)

Allowable limit : 1.85 mm (0.0728 in)

Forward clutch retaining plate : Refer to [AT-377, "FORWARD CLUTCH"](#) .

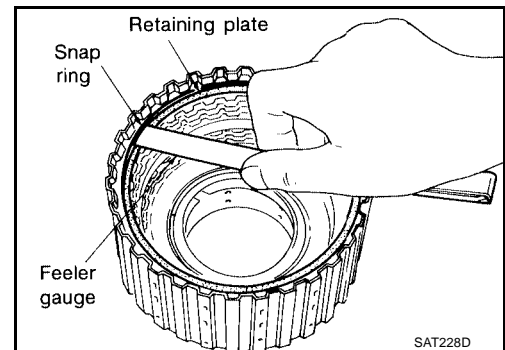

12. Check operation of forward clutch.
13. Check operation of overrun clutch.

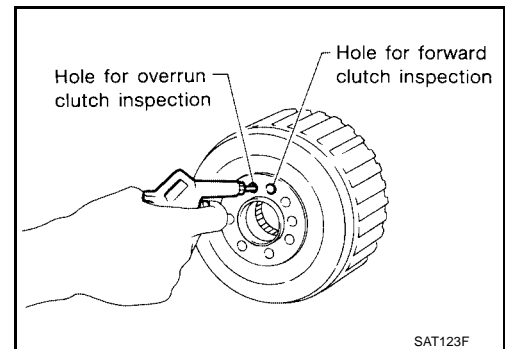

A
B
AT
D
E
F
G
H
I
J
K
L
M

REPAIR FOR COMPONENT PARTS

ECS006FJ

Low & Reverse Brake COMPONENTS

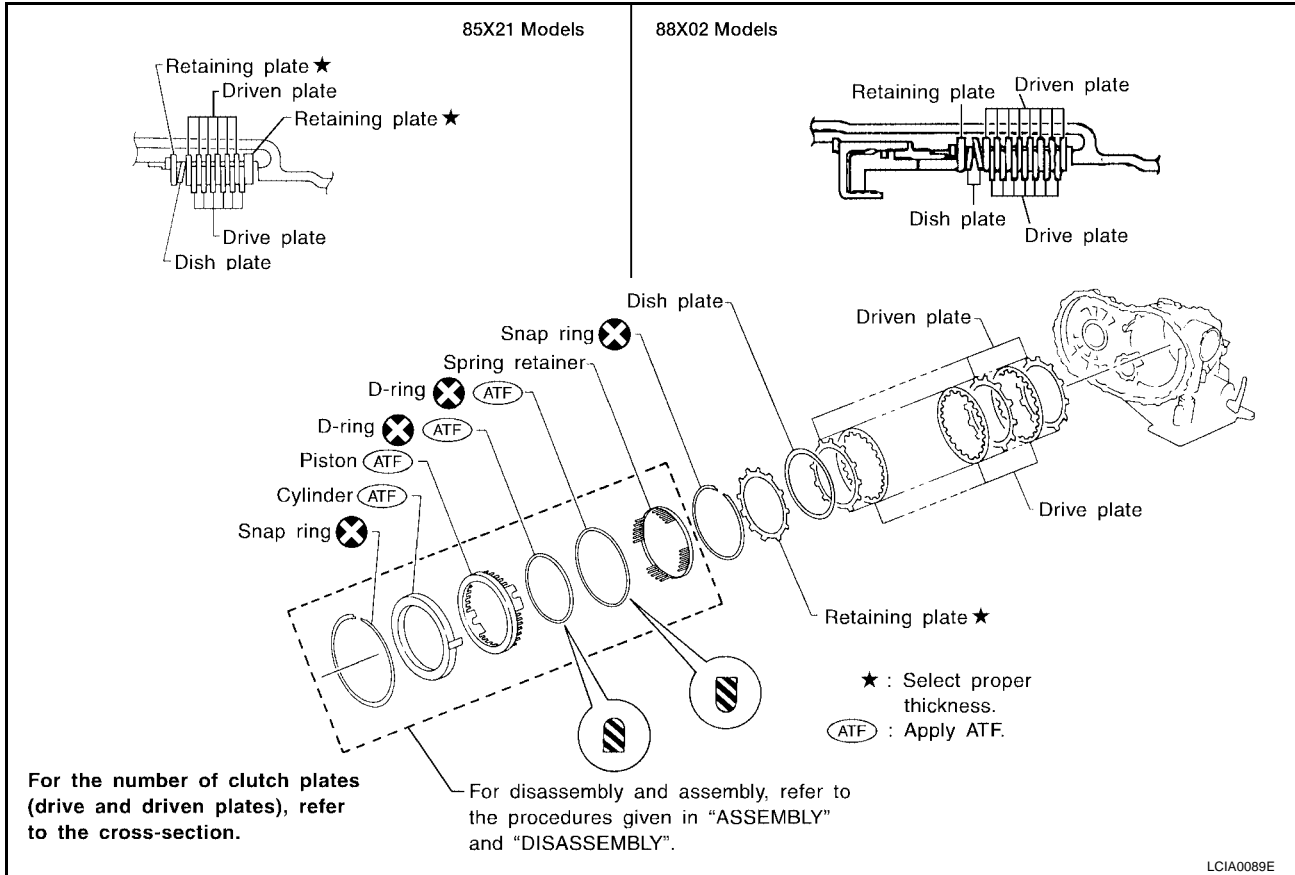

DISASSEMBLY

1. Check operation of low & reverse brake.
 - a. Apply compressed air to oil hole of transmission case.
 - b. Check to see that retaining plate moves to snap ring.
 - c. If retaining plate does not contact snap ring:
 - D-ring might be damaged.
 - Fluid might be leaking past piston check ball.

2. In order to remove piston, apply compressed air to oil hole of retainer while holding piston.
 - Apply air gradually and allow piston to come out evenly.

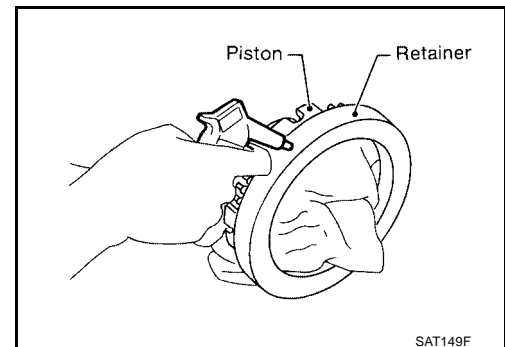
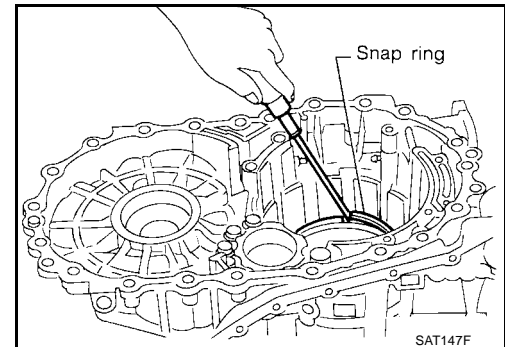

REPAIR FOR COMPONENT PARTS

3. Remove D-rings from piston.

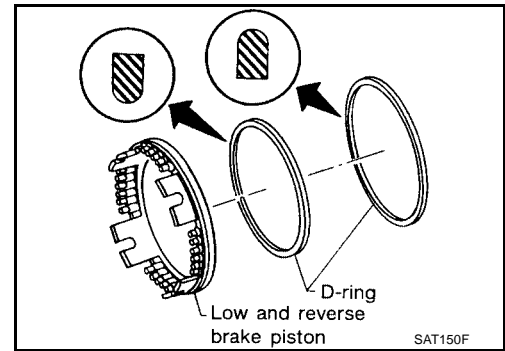

INSPECTION

Low and Reverse Brake Snap Ring, Spring Retainer and Return Springs

- Check for deformation, fatigue or damage. If necessary, replace.
- **When replacing spring retainer and return springs, replace them as a set.**

Low and Reverse Brake Drive Plate

- Check facing for burns, cracks or damage.
- Measure thickness of facing.

Thickness of drive plate

Standard value : 1.8 mm (0.071 in)

Wear limit : 1.6 mm (0.063 in)

- If not within wear limit, replace.

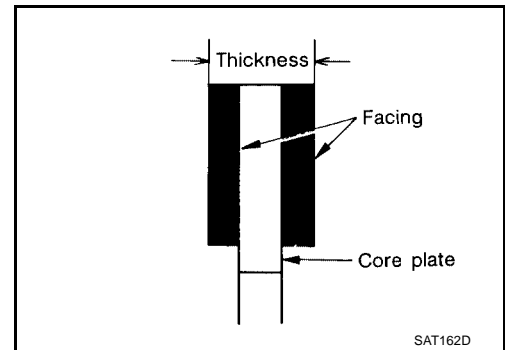

ASSEMBLY

1. Install D-rings on piston.
 - **Apply ATF to both parts.**

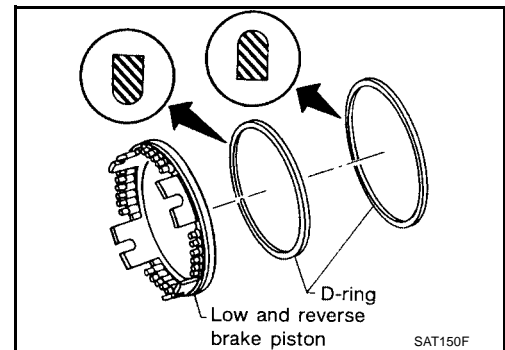

2. Set and align piston with retainer.
 - **This operation is required in order to engage the protrusions of piston to return springs correctly. Further procedures are given in "ASSEMBLY".**

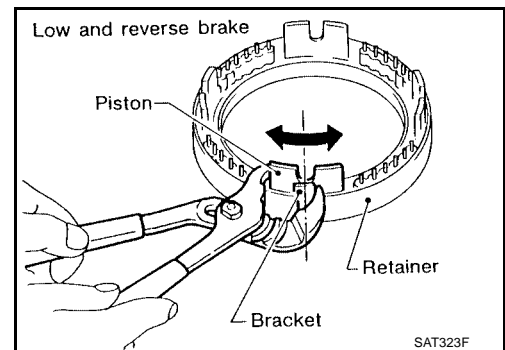

REPAIR FOR COMPONENT PARTS

3. Install driven plates, drive plates, retaining plate and dish plate on transmission case.
- Take care with order of plates and direction of dish plate.

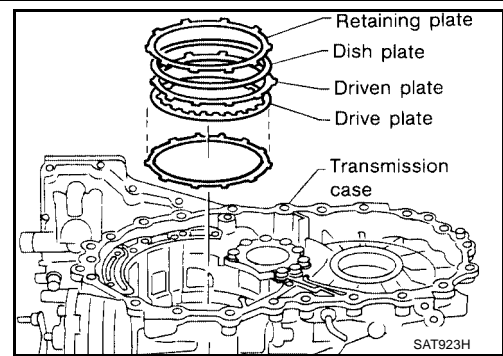

4. Install snap ring.

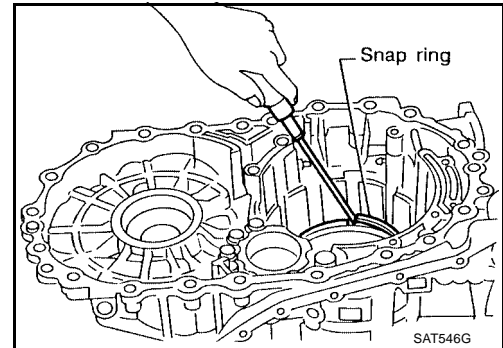

5. Measure clearance between driven plate and transmission case. If not within allowable limit, select proper retaining plate. (front side)

Specified clearance

Standard : 1.7 - 2.1 mm (0.067 - 0.083 in)

Allowable limit : 3.3 mm (0.130 in)

Retaining plate Refer to [AT-377, "LOW & REVERSE BRAKE"](#) .

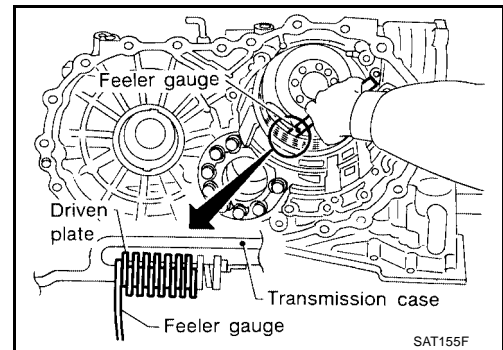

REPAIR FOR COMPONENT PARTS

Rear Internal Gear, Forward Clutch Hub and Overrun Clutch Hub COMPONENTS

ECS006FK

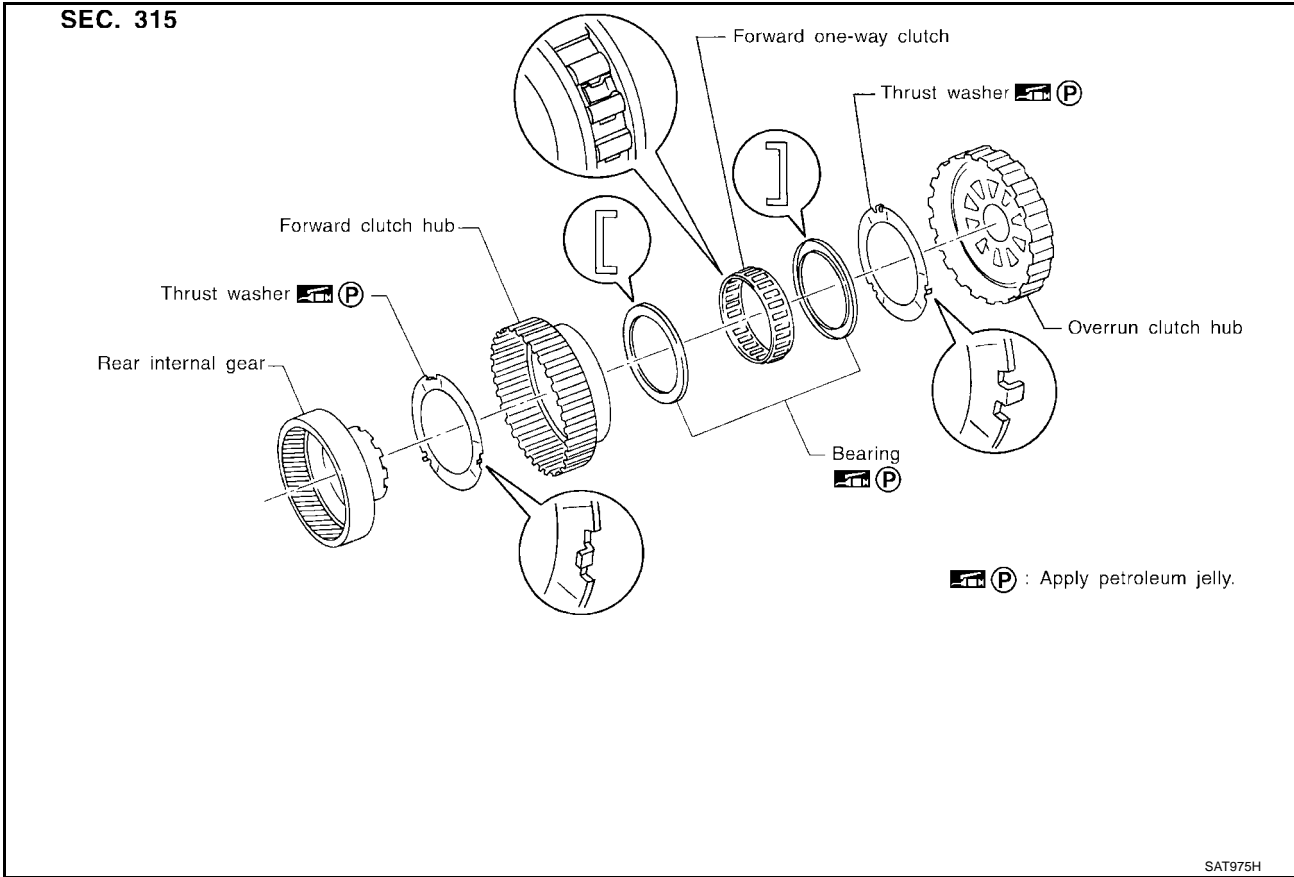

DISASSEMBLY

1. Remove overrun clutch hub and thrust washer from forward clutch hub.

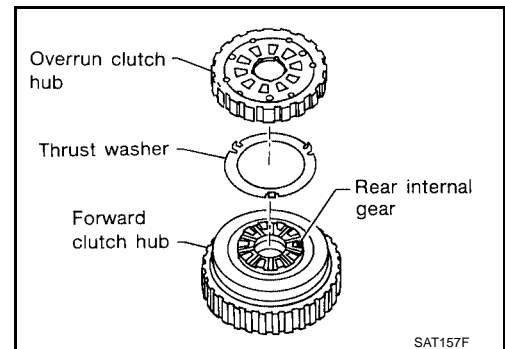

2. Remove forward clutch hub from rear internal gear.

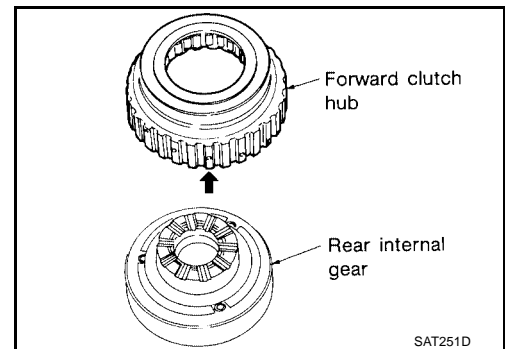

A
B
AT
D
E
F
G
H
I
J
K
L
M

REPAIR FOR COMPONENT PARTS

3. Remove bearing from rear internal gear.

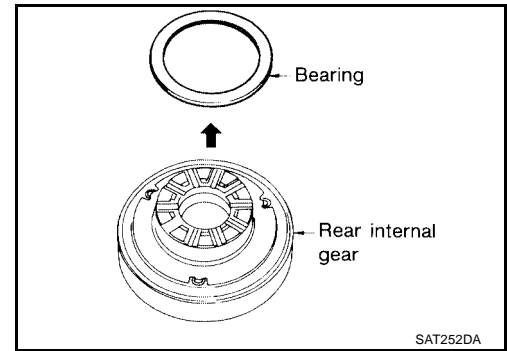

4. Remove thrust washer from rear internal gear.

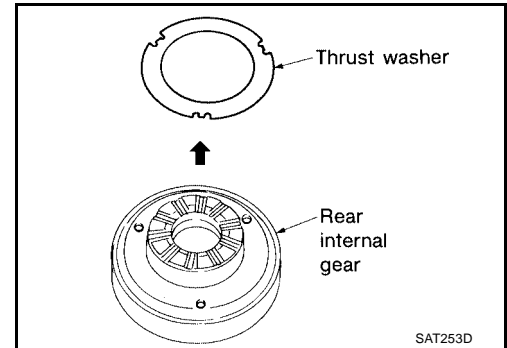

5. Remove bearing from forward one-way clutch.

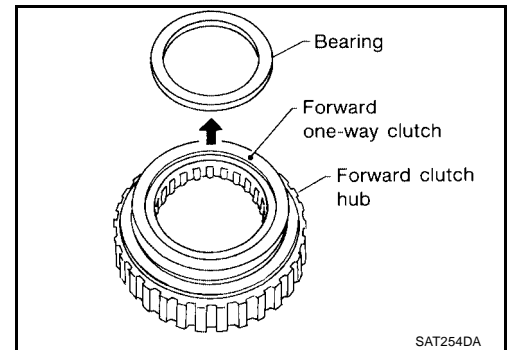

6. Remove forward one-way clutch from forward clutch hub.

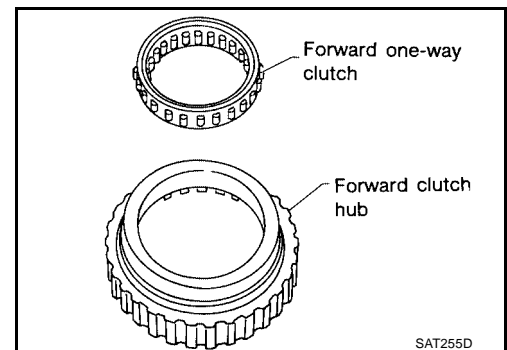

REPAIR FOR COMPONENT PARTS

INSPECTION

Rear Internal Gear, Forward Clutch Hub and Overrun Clutch Hub

- Check rubbing surfaces for wear or damage.

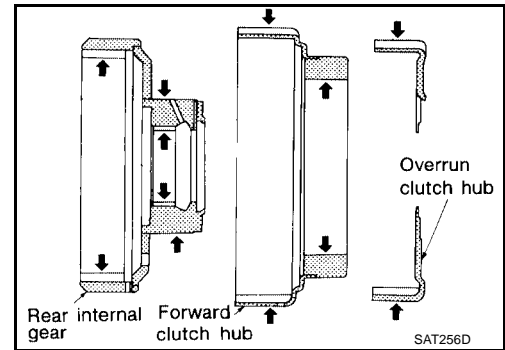

Bearings and Forward One-Way Clutch

- Check bearings for deformation and damage.
- Check forward one-way clutch for wear and damage.

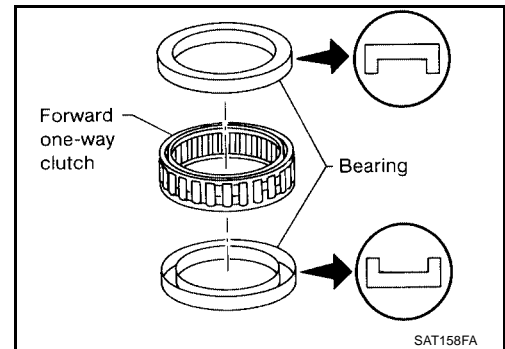

ASSEMBLY

1. Install forward one-way clutch on forward clutch.
 - Take care with the direction of forward one-way clutch.

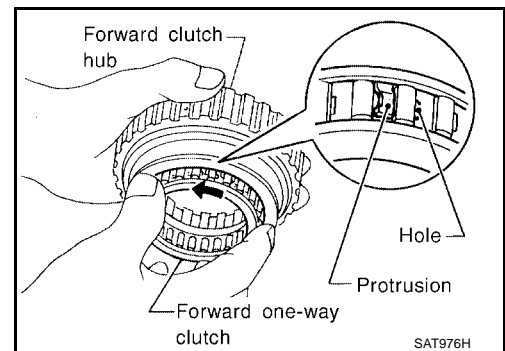

2. Install bearing on forward one-way clutch.
 - Apply petroleum jelly to bearing.

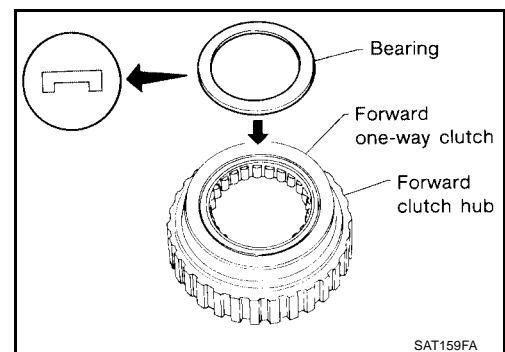

A
B
AT
D
E
F
G
H
I
J
K
L
M

REPAIR FOR COMPONENT PARTS

3. Install thrust washer on rear internal gear.
- Apply petroleum jelly to thrust washer.
 - Align hooks of thrust washer with holes of rear internal gear.

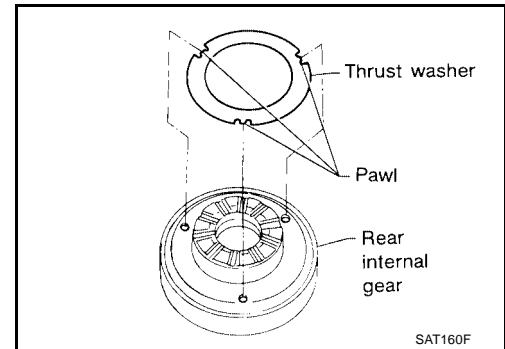

4. Install bearing on rear internal gear.
- Apply petroleum jelly to bearing.

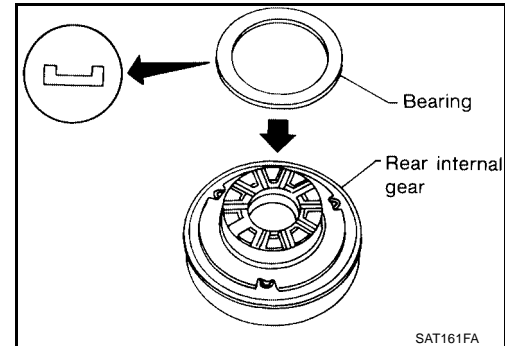

5. Install thrust washer and overrun clutch hub.
- Apply petroleum jelly to thrust washer.
 - Align hooks of thrust washer with holes of overrun clutch hub.
 - Align projections of rear internal gear with holes of overrun clutch hub.

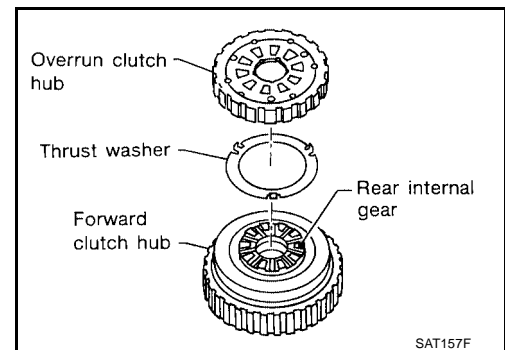

6. Install forward clutch hub on rear internal gear.
- Check operation of forward one-way clutch. Hold rear internal gear and turn forward clutch hub. Check forward clutch hub for correct locking and unlocking directions.
 - If not as shown in illustration, check installation direction of forward one-way clutch.

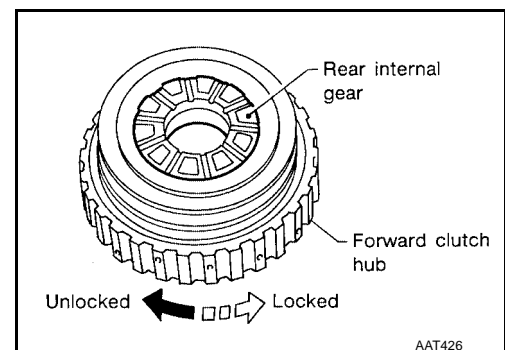

REPAIR FOR COMPONENT PARTS

Output Shaft, Idler Gear, Reduction Pinion Gear and Bearing Retainer COMPONENTS

ECS006FL

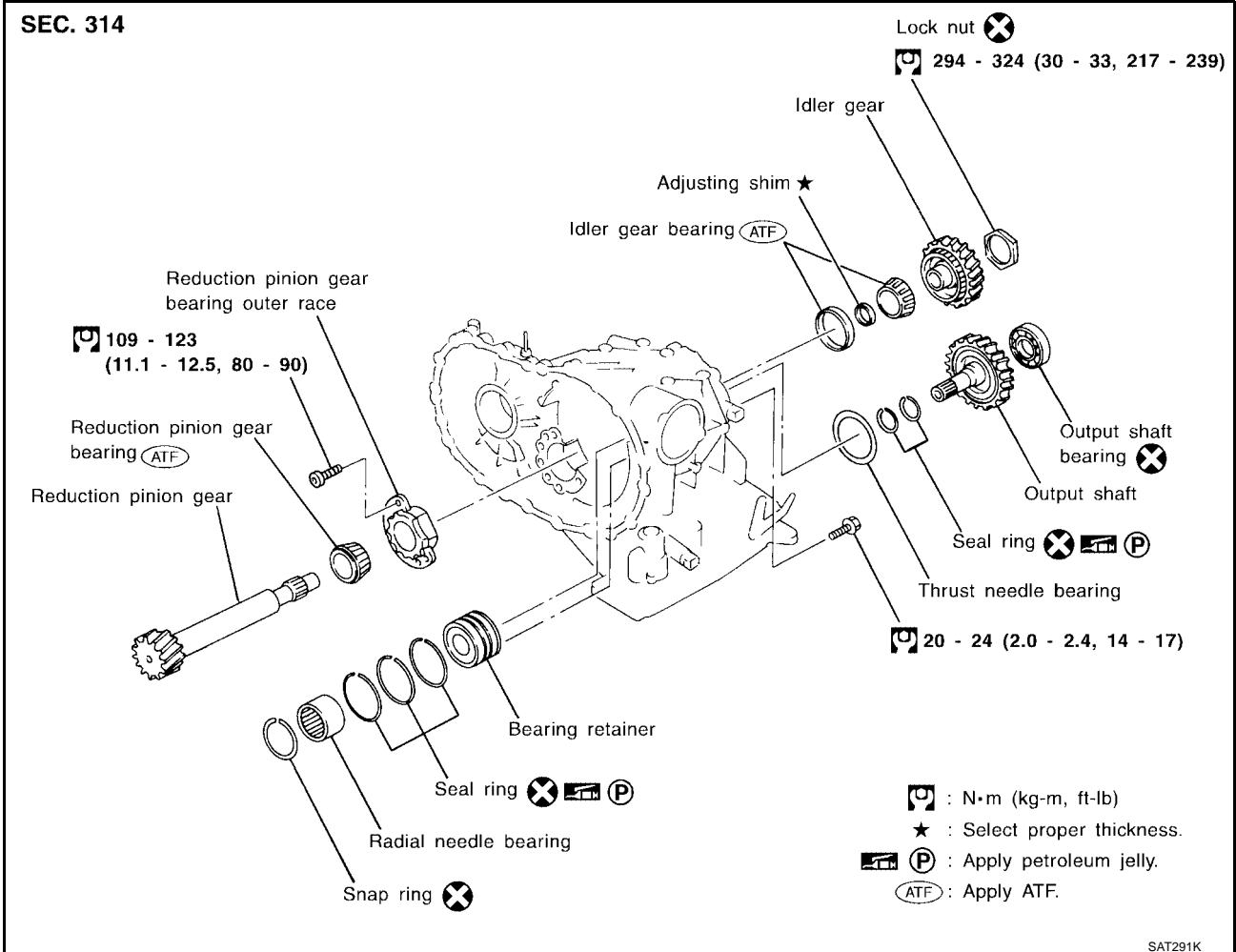

DISASSEMBLY

1. Remove seal rings from output shaft and bearing retainer.

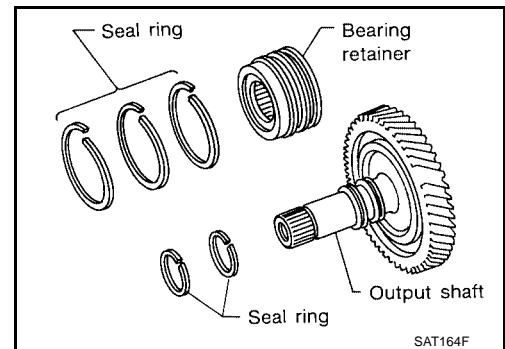

2. Remove output shaft bearing with screwdrivers.
 - Always replace bearing with a new one when removed.
 - Do not damage output shaft.

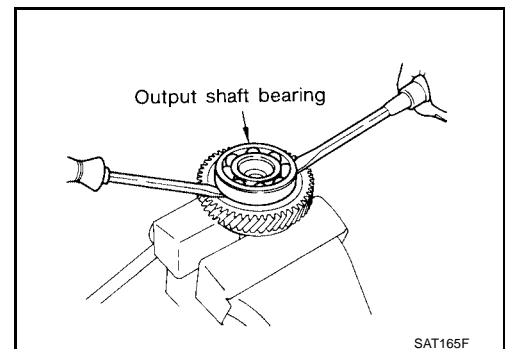

REPAIR FOR COMPONENT PARTS

3. Remove snap ring from bearing retainer.

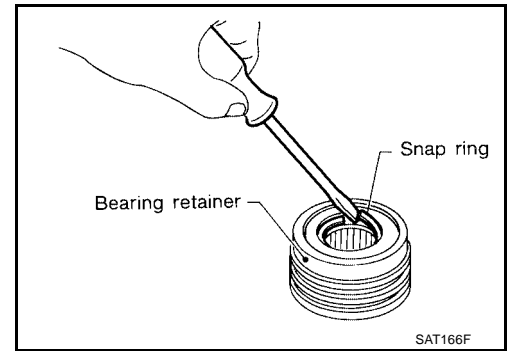

4. Remove needle bearing from bearing retainer.

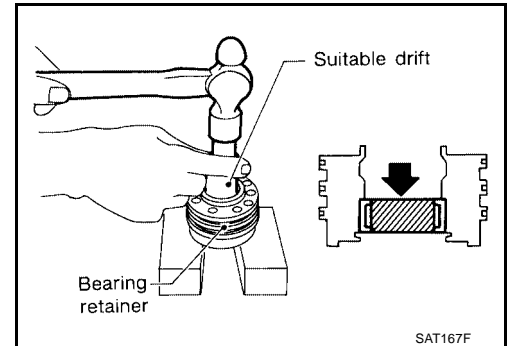

5. Remove idler gear bearing inner race from idler gear.

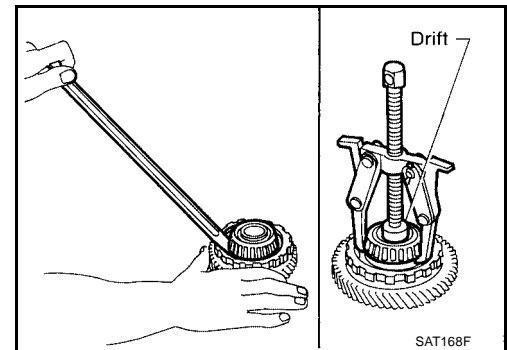

6. Remove idler gear bearing outer race from transmission case.

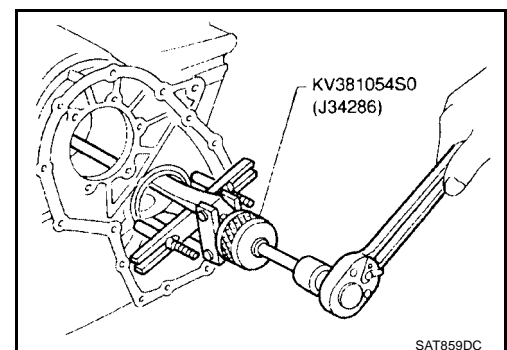

7. Press out reduction pinion gear bearing inner race from reduction pinion gear.

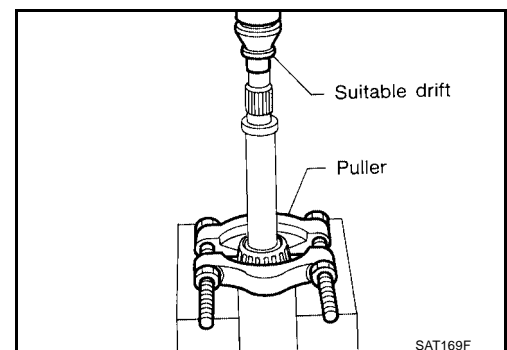

REPAIR FOR COMPONENT PARTS

- Remove reduction pinion gear bearing outer race from transmission case.

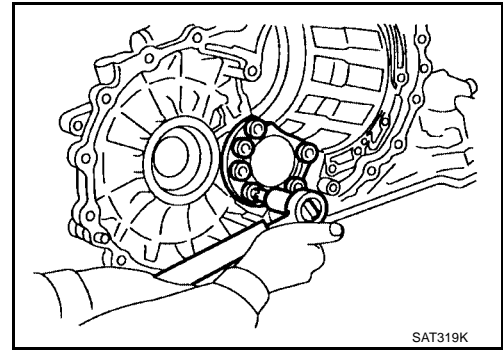

INSPECTION

Output Shaft, Idler Gear and Reduction Pinion Gear

- Check shafts for cracks, wear or bending.
- Check gears for wear, chips and cracks.

Bearing

- Make sure bearings roll freely and are free from noise, cracks, pitting or wear.
- When replacing taper roller bearing, replace outer and inner race as a set.**

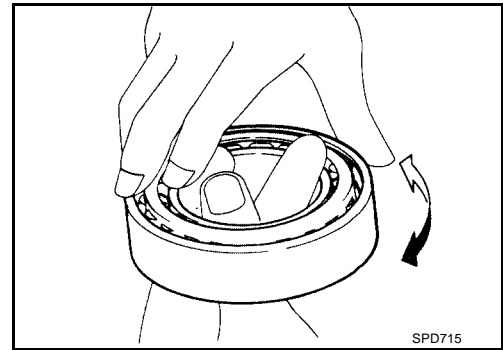

Seal Ring Clearance

- Install new seal rings to output shaft.
- Measure clearance between seal ring and ring groove of output shaft.

Standard clearance : 0.10 - 0.25 mm
(0.0039 - 0.0098 in)

Allowable limit : 0.25 mm (0.0098 in)

- If not within allowable limit, replace output shaft.
- Install new seal rings to bearing retainer.
- Measure clearance between seal ring and ring groove of bearing retainer.

Standard clearance : 0.10 - 0.30 mm (0.0039 - 0.0118 in)

Allowable limit : 0.30 mm (0.0118 in)

- If not within allowable limit, replace bearing retainer.

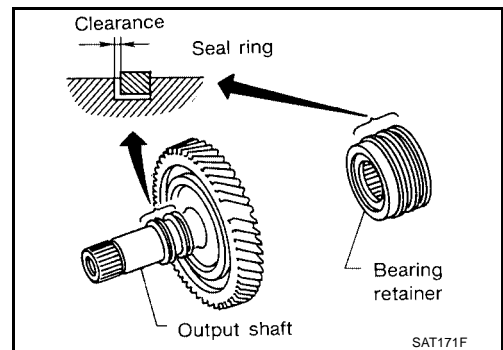

A
B
AT
D
E
F
G
H
I
J
K
L
M

REPAIR FOR COMPONENT PARTS

ASSEMBLY

1. Press reduction pinion gear bearing inner race on reduction pinion gear.

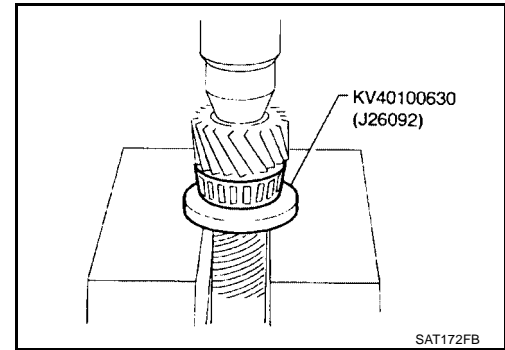

2. Install reduction pinion gear bearing outer race on transmission case.



: 109 - 123 N-m (11.1 - 12.5 kg-m, 80 - 90 ft-lb)

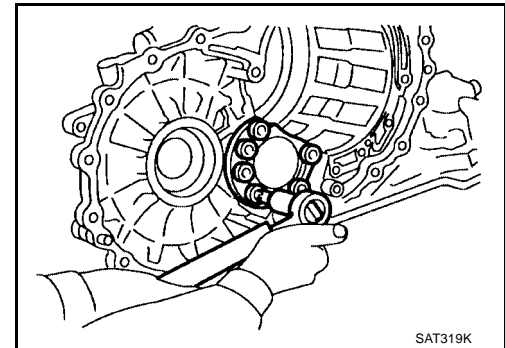

3. Press idler gear bearing inner race on idler gear.

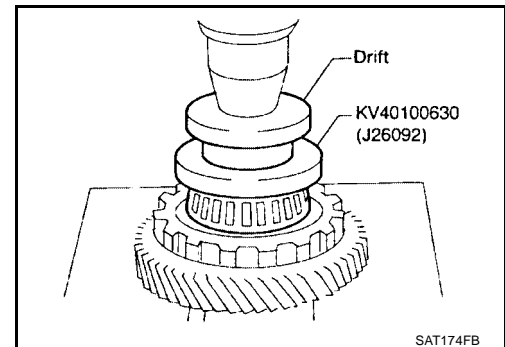

4. Install idler gear bearing outer race on transmission case.

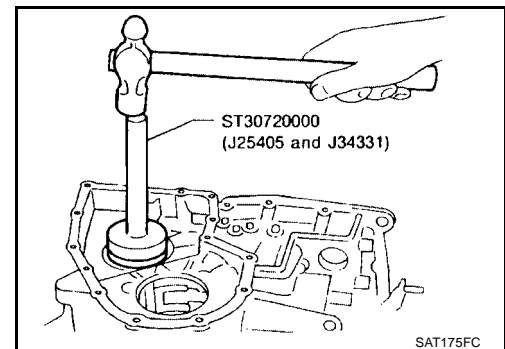

REPAIR FOR COMPONENT PARTS

5. Press output shaft bearing on output shaft.

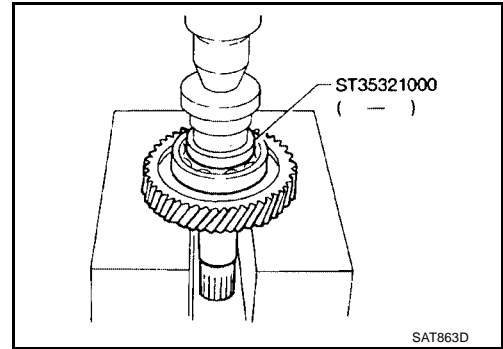

6. Press needle bearing on bearing retainer.

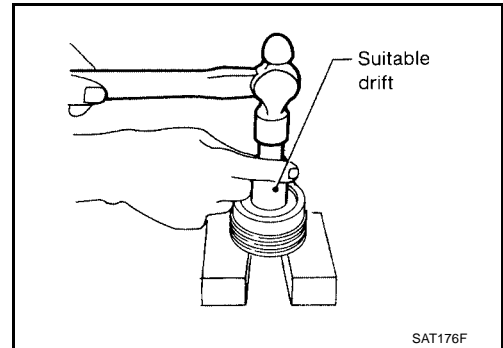

7. Install snap ring to bearing retainer.

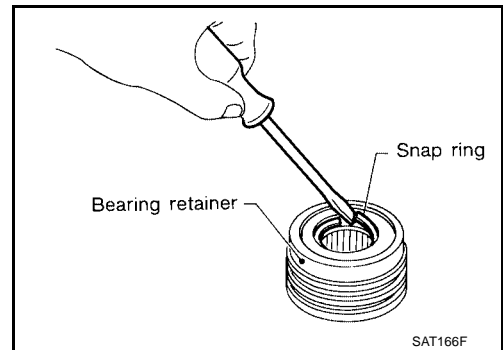

8. After packing ring grooves with petroleum jelly, carefully install new seal rings on output shaft and bearing retainer.

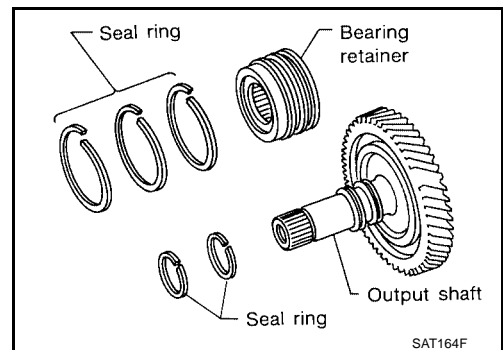

● Roll paper around seal rings to prevent seal rings from spreading.

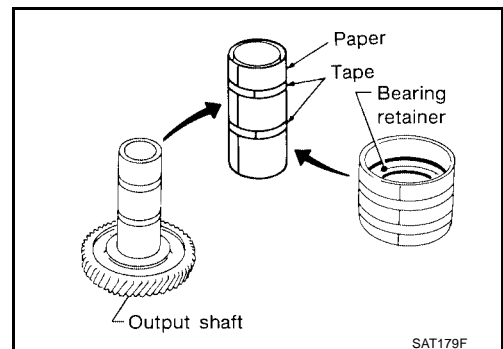

A
B
AT
D
E
F
G
H
I
J
K
L
M

REPAIR FOR COMPONENT PARTS

ECS006FM

Band Servo Piston Assembly COMPONENTS

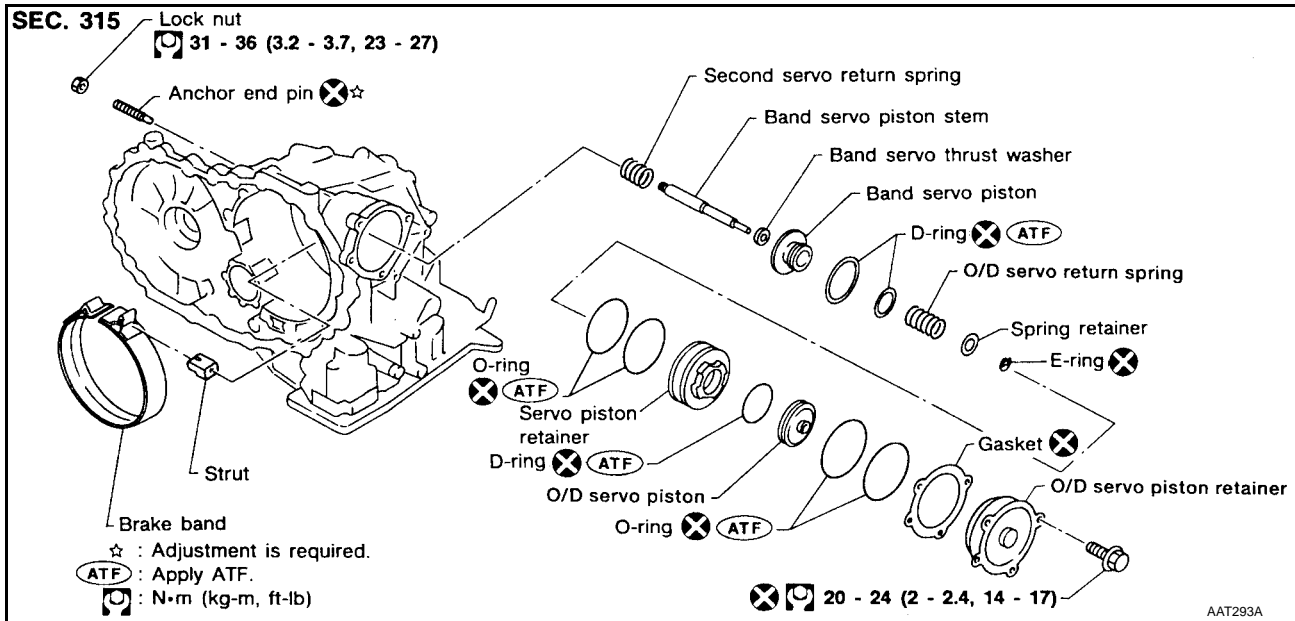

DISASSEMBLY

1. Remove band servo piston fixing bolts.

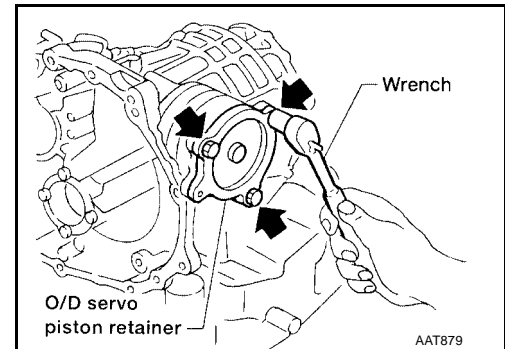

2. Apply compressed air to oil hole in transmission case to remove O/D servo piston retainer and band servo piston assembly.
 - Hold band servo piston assembly with a rag or nylon waste.

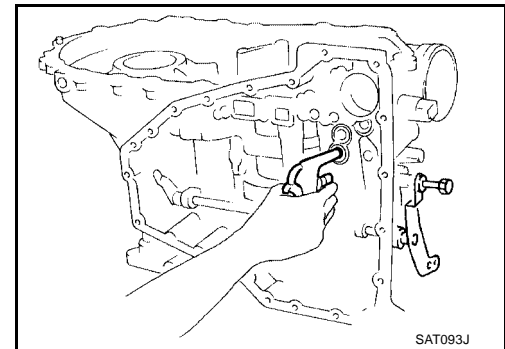

3. Apply compressed air to oil hole in O/D servo piston retainer to remove O/D servo piston from retainer.
 - Hold O/D band servo piston while applying compressed air.

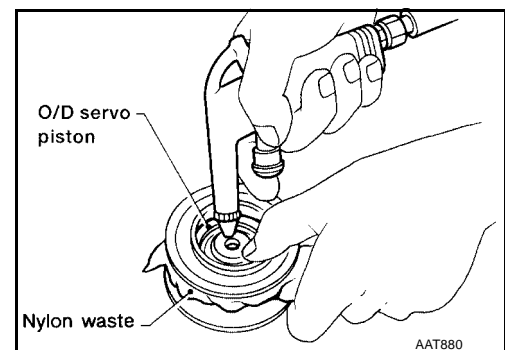

REPAIR FOR COMPONENT PARTS

4. Remove D-ring from O/D servo piston.

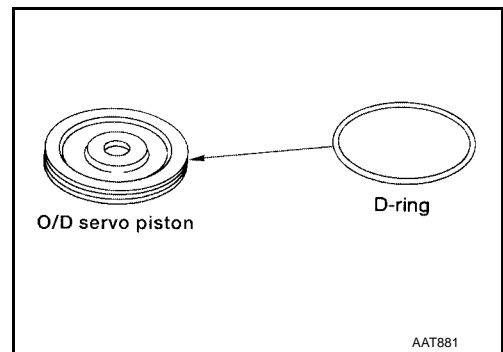

5. Remove O-rings from O/D servo piston retainer.

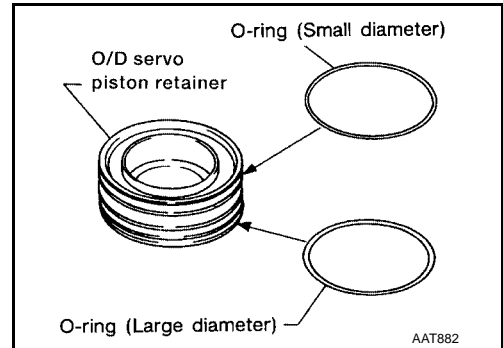

6. Remove band servo piston assembly from servo piston retainer by pushing it forward.

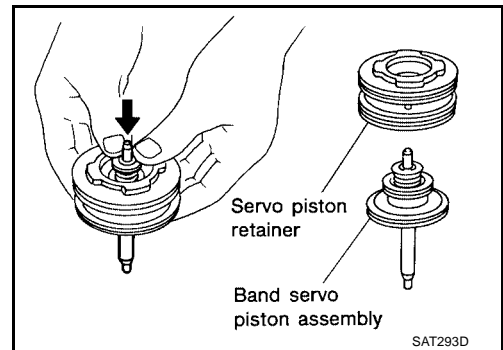

7. Place piston stem end on a wooden block. While pushing servo piston spring retainer down, remove E-ring.

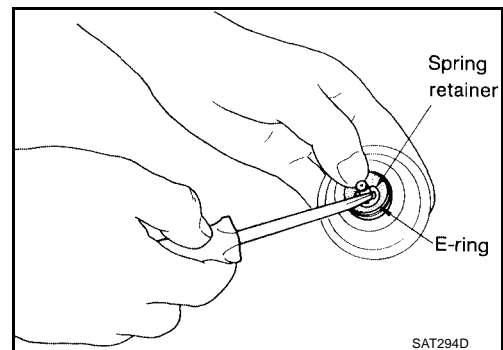

8. Remove O/D servo return spring, band servo thrust washer and band servo piston stem from band servo piston.

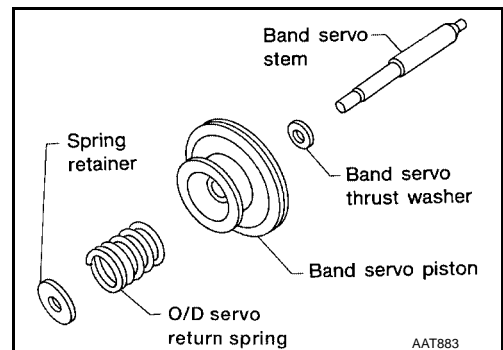

A
B
AT
D
E
F
G
H
I
J
K
L
M

REPAIR FOR COMPONENT PARTS

9. Remove O-rings from servo piston retainer.

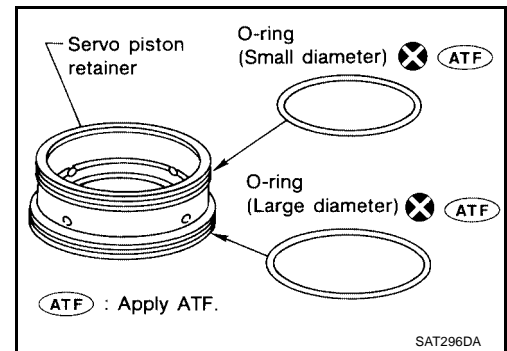

10. Remove D-rings from band servo piston.

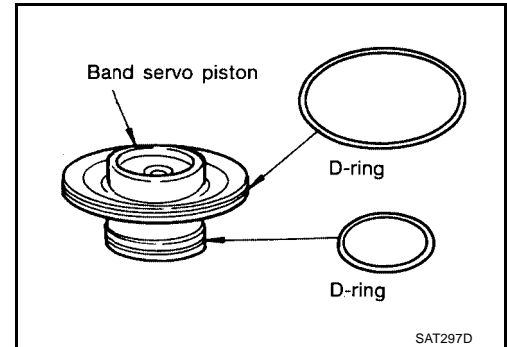

INSPECTION

Pistons, Retainers and Piston Stem

- Check frictional surfaces for abnormal wear or damage.

Return Springs

- Check for deformation or damage.
- Measure free length and outer diameter.

Inspection standard : Refer to [AT-380, "Band Servo"](#)

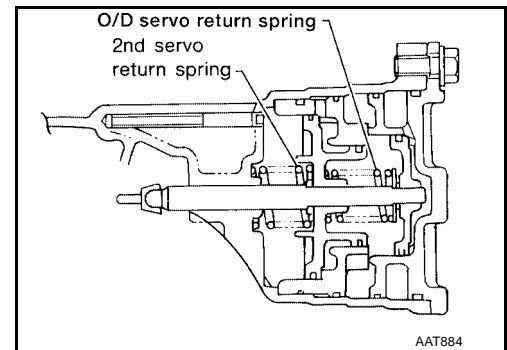

ASSEMBLY

1. Install D-rings to servo piston retainer.

- **Apply ATF to D-rings.**
- **Pay attention to position of each O-ring.**

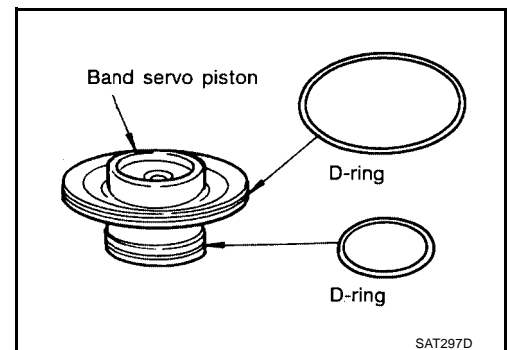

REPAIR FOR COMPONENT PARTS

2. Install band servo piston stem, band servo thrust washer, O/D servo return spring and spring retainer to band servo piston.

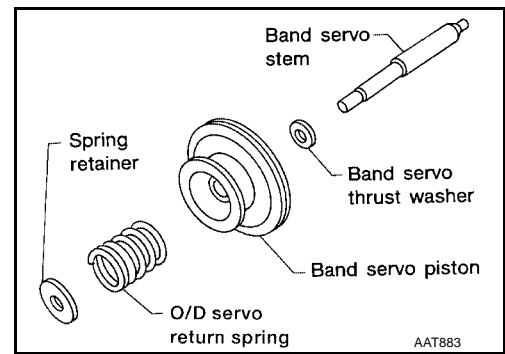

3. Place piston stem end on a wooden block. While pushing servo piston spring retainer down, install E-ring.

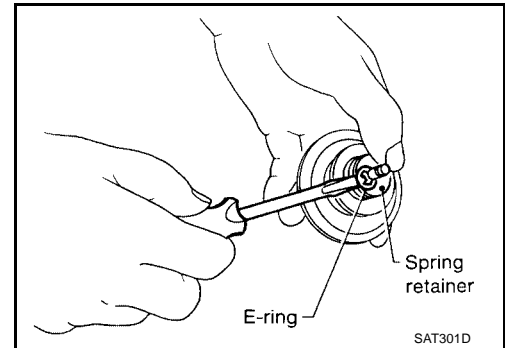

4. Install O-rings to servo piston retainer.
- **Apply ATF to O-rings.**
 - **Pay attention to position of each O-ring.**

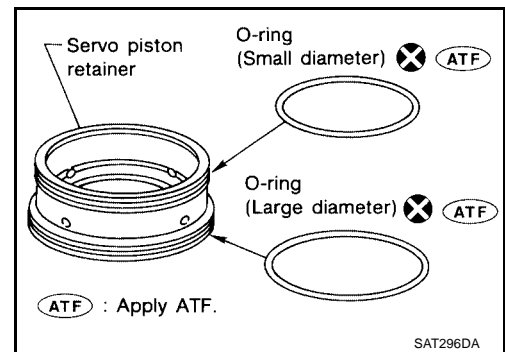

5. Install band servo piston assembly to servo piston retainer by pushing it inward.

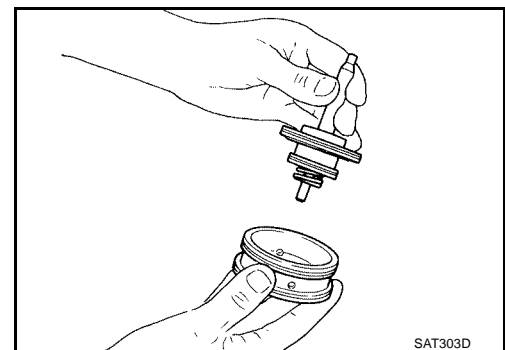

6. Install D-ring to O/D servo piston.
- **Apply ATF to D-ring.**

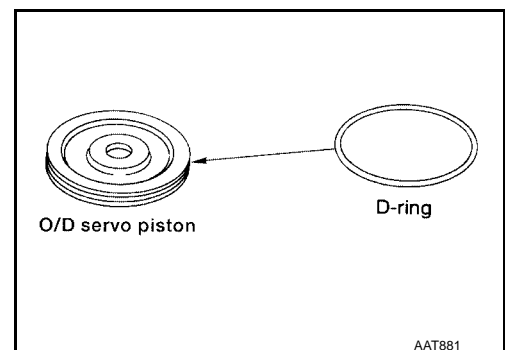

REPAIR FOR COMPONENT PARTS

7. Install O-rings to O/D servo piston retainer.

- Apply ATF to O-rings.
- Pay attention to position of each O-ring.

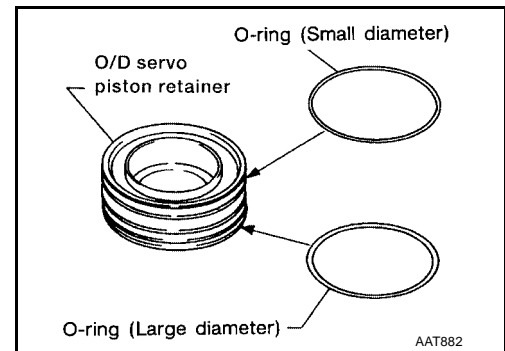

8. Install O/D servo piston to O/D servo piston retainer.

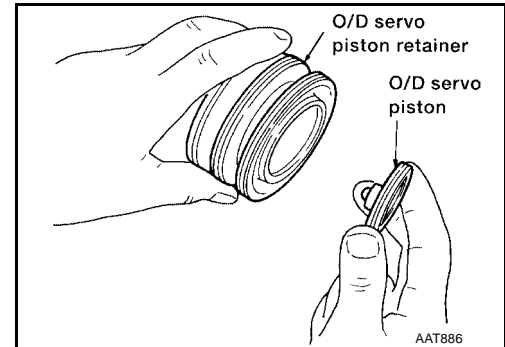

9. Install band servo piston assembly and 2nd servo return spring to transmission case.

- Apply ATF to O-ring of band servo piston and transmission case.

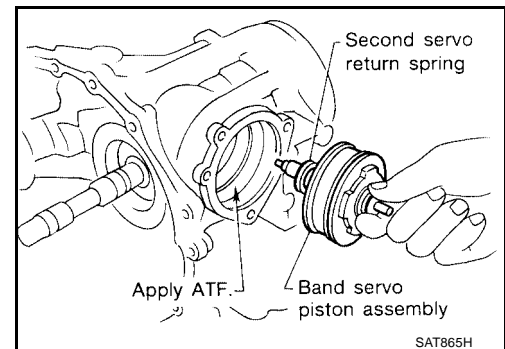

10. Install O/D servo piston assembly to transmission case.

- Apply ATF to O-ring of band servo piston and transmission case.

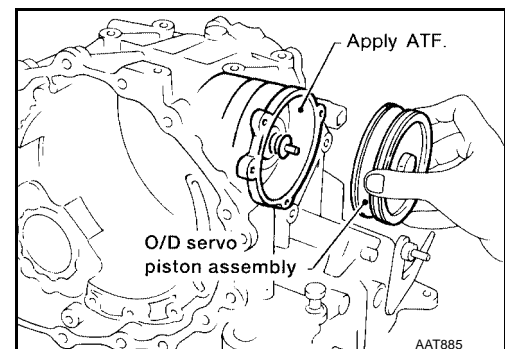

11. Install O/D servo piston retainer to transmission case.

Refer to [AT-340, "COMPONENTS"](#).

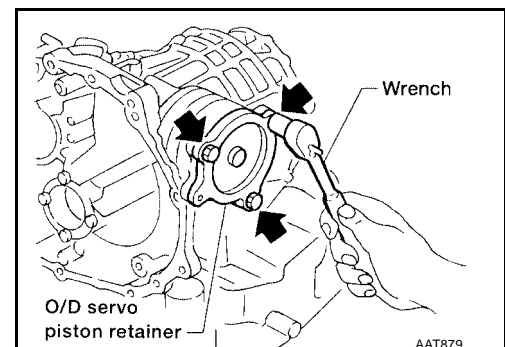

REPAIR FOR COMPONENT PARTS

ECS006FN

Final Drive COMPONENTS

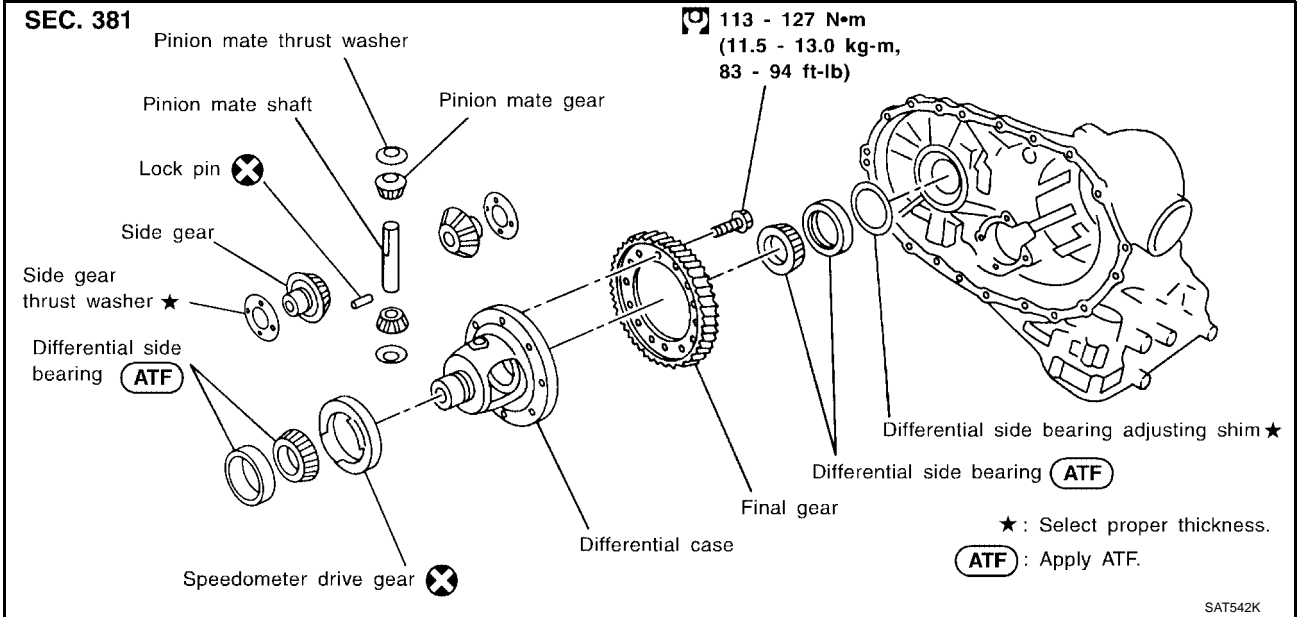

DISASSEMBLY

1. Remove final gear.

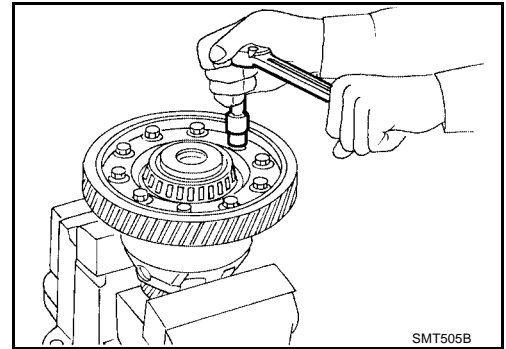

2. Press out differential side bearings.
 - Be careful not to mix up the right and left bearings.

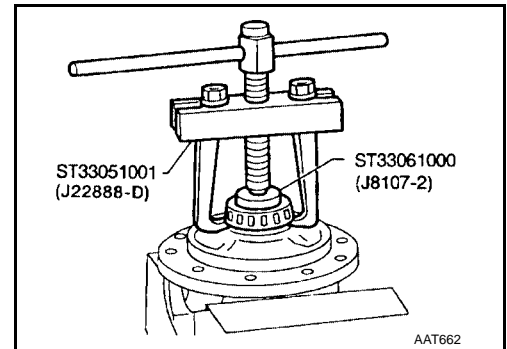

3. Remove differential side bearing outer race and side bearing adjusting shim from transmission case.

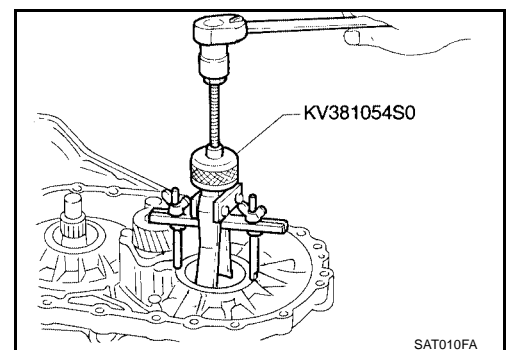

REPAIR FOR COMPONENT PARTS

4. Remove speedometer drive gear.

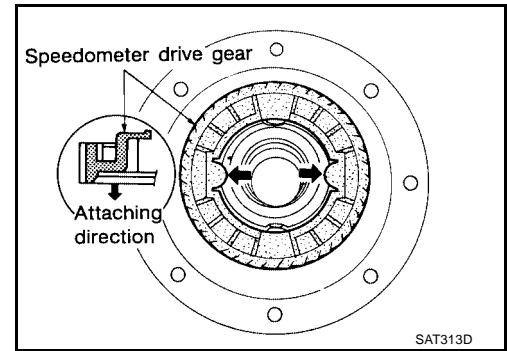

5. Drive out pinion mate shaft lock pin.

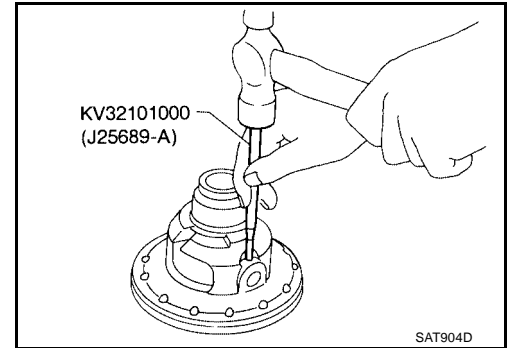

6. Draw out pinion mate shaft lock pin.
7. Remove pinion mate gears and side gears.

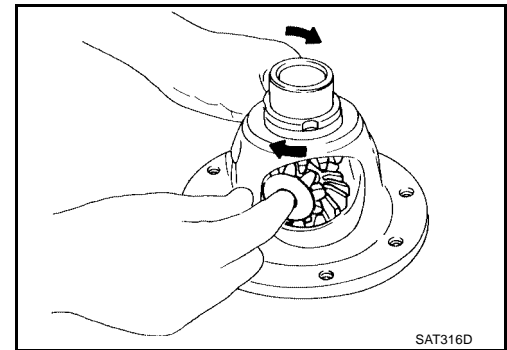

INSPECTION

Gear, Washer, Shaft and Case

- Check mating surfaces of differential case, side gears and pinion mate gears.
- Check washers for wear.

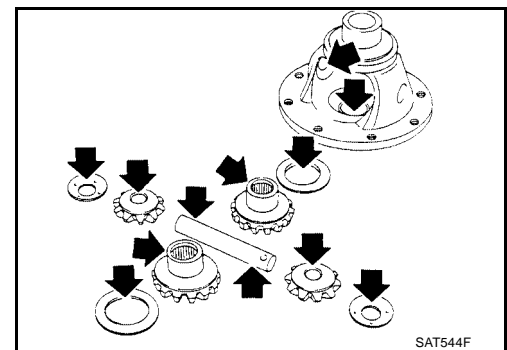

REPAIR FOR COMPONENT PARTS

Bearings

- Make sure bearings roll freely and are free from noise, cracks, pitting or wear.
- **When replacing taper roller bearing, replace outer and inner race as a set.**

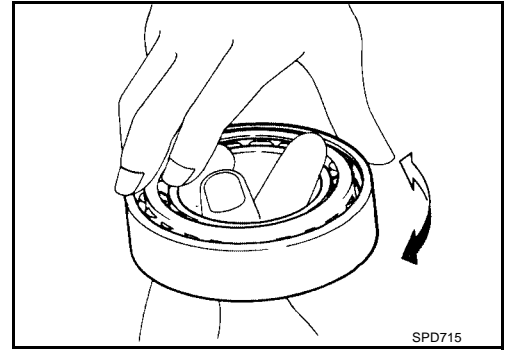

ASSEMBLY

1. Attach side gear thrust washers to side gears, then install pinion mate thrust washers and pinion mate gears in place.
 - **Apply ATF to any parts.**

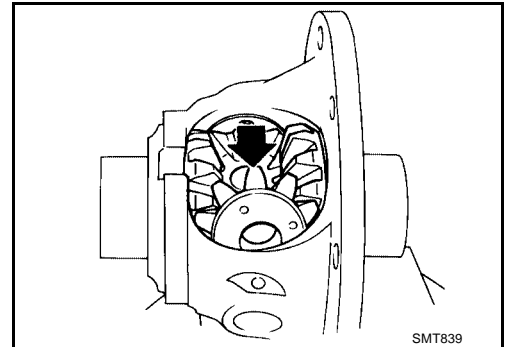

2. Insert pinion mate shaft.
 - **When inserting, be careful not to damage pinion mate thrust washers.**

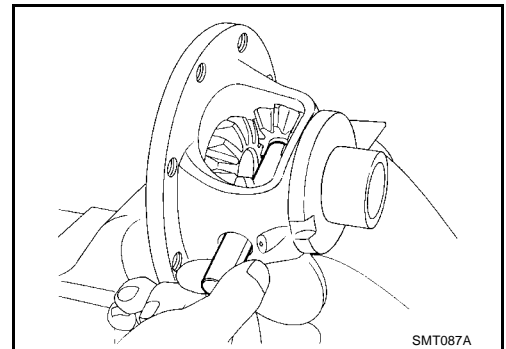

3. Measure clearance between side gear and differential case with washers following the procedure below:
 - a. Set Tool and dial indicator on side gear.

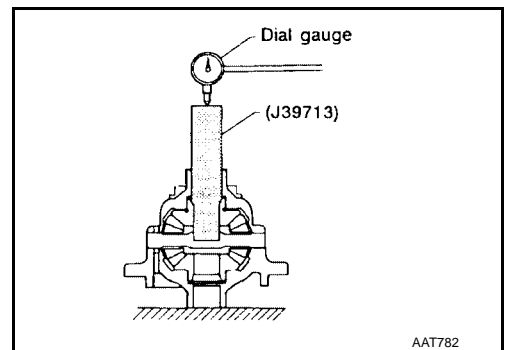

A
B
AT
D
E
F
G
H
I
J
K
L
M

REPAIR FOR COMPONENT PARTS

- b. Move side gear up and down to measure dial indicator deflection. Always measure indicator deflection on both side gears.

Clearance between side gear and differential case with washer : 0.1 - 0.2 mm (0.004 - 0.008 in)

- c. If not within specification, adjust clearance by changing thickness of differential side gear thrust washers.

Differential side gear thrust washers : Refer to AT-378, "DIFFERENTIAL SIDE GEAR THRUST WASHERS" .

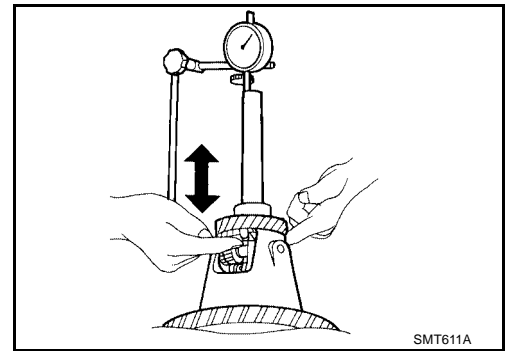

4. Install lock pin.

- **Make sure that lock pin is flush with case.**

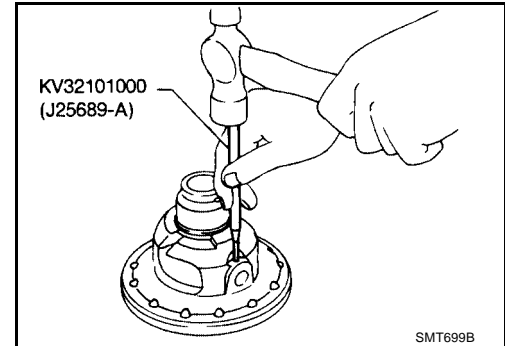

5. Install speedometer drive gear on differential case.

- **Align the projection of speedometer drive gear with the groove of differential case.**

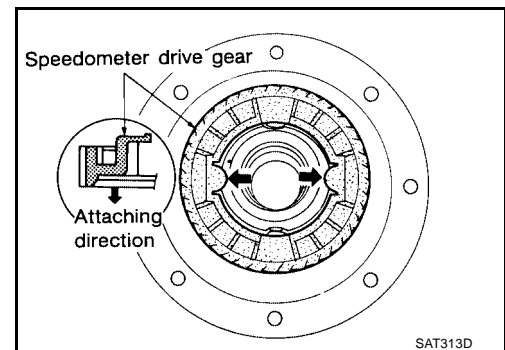

6. Press on differential side bearings.

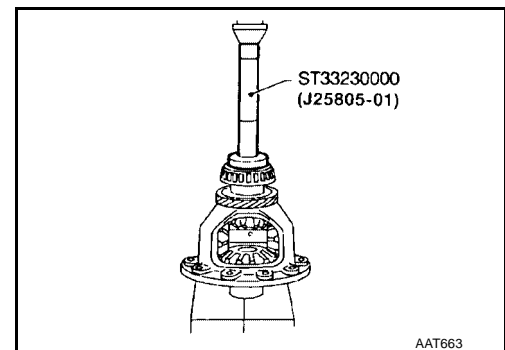

REPAIR FOR COMPONENT PARTS

7. Install final gear and tighten fixing bolts in a crisscross pattern. Tighten final gear bolts to the specified torque. Refer to [AT-345](#), "[COMPONENTS](#)".

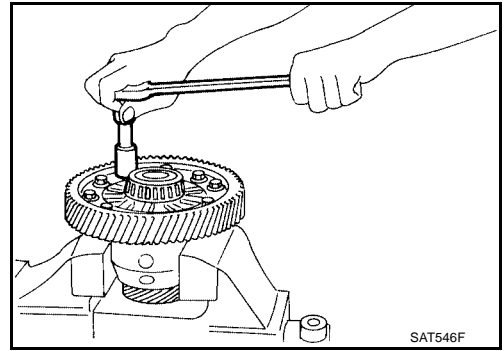

A

B

AT

D

E

F

G

H

I

J

K

L

M

ASSEMBLY

ASSEMBLY

PFP:00000

Assembly (1)

ECS006FO

1. Install differential side oil seals on transmission case and converter housing.

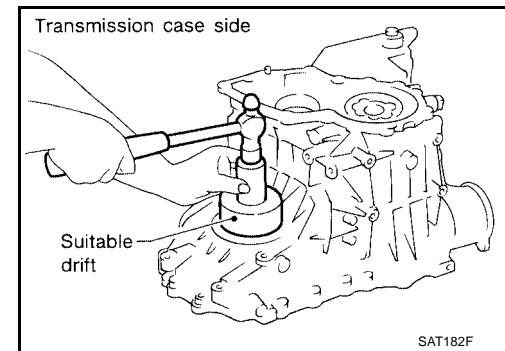
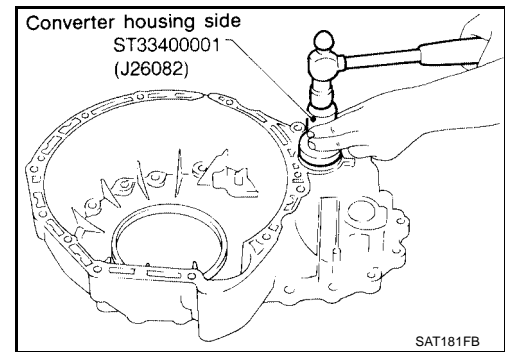

2. Install parking actuator support to transmission case. Tighten parking actuator support bolts to the specified torque. Refer to [AT-272, "OVERHAUL"](#).
 - Pay attention to direction of parking actuator support.

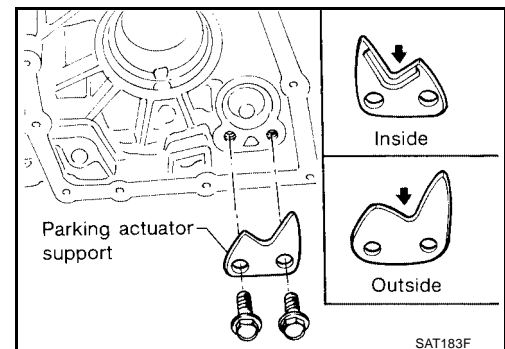

3. Install parking pawl on transmission case and fix it with parking shaft.
4. Install return spring.

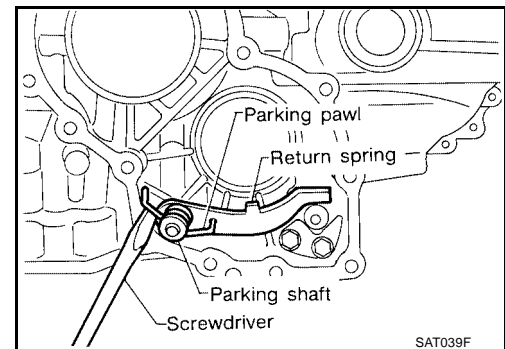

ASSEMBLY

ECS006FP

Adjustment (1)

DIFFERENTIAL SIDE BEARING PRELOAD

1. Install differential side bearing outer race without adjusting shim on transmission case.
2. Install differential side bearing outer race on converter housing.

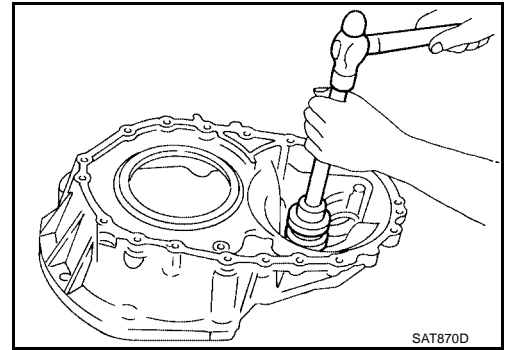

3. Place final drive assembly on transmission case.
4. Install transmission case on converter housing. Tighten transmission case fixing bolts to the specified torque. Refer to [AT-272, "OVERHAUL"](#).

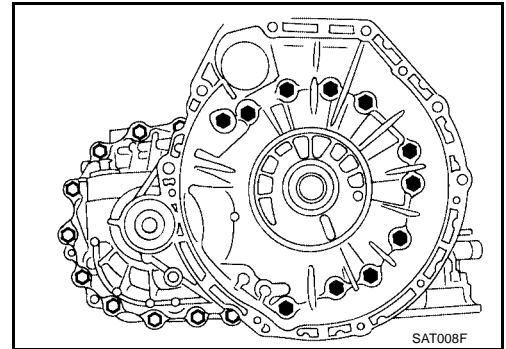

5. Attach dial indicator on differential case at converter housing side.
6. Insert Tool into differential side gear from transmission case side.
7. Move Tool up and down and measure dial indicator deflection.
8. Select proper thickness of differential side bearing adjusting shim(s).

Suitable shim thickness = Dial indicator deflection + Specified bearing preload

Differential side bearing preload adjusting shim : Refer to [AT-379, "DIFFERENTIAL SIDE BEARING PRELOAD ADJUSTING SHIMS"](#).

Bearing preload : 0.05 - 0.09 mm (0.0020 - 0.0035 in)

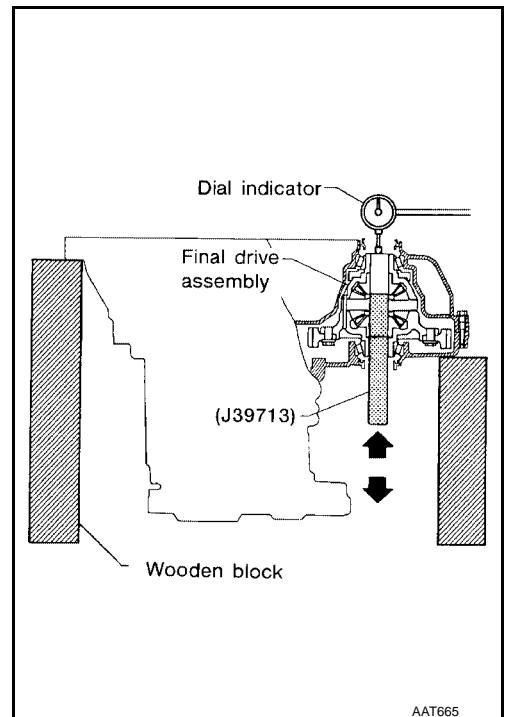

ASSEMBLY

9. Remove converter housing from transmission case.
10. Remove final drive assembly from transmission case.
11. Remove differential side bearing outer race from transmission case.
12. Reinstall differential side bearing outer race and shim(s) selected from SDS table on transmission case.
13. Reinstall converter housing on transmission case and tighten transmission case fixing bolts to the specified torque. Refer to [AT-272, "OVERHAUL"](#) .

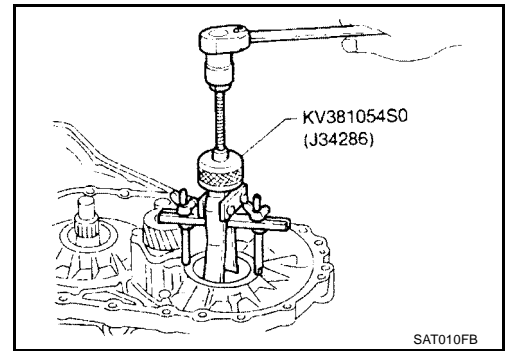

14. Insert Tool and measure turning torque of final drive assembly.
 - Turn final drive assembly in both directions several times to seat bearing rollers correctly.

Turning torque of final drive assembly (New bearing) : 0.78 - 1.37 N-m (8.0 - 14.0 kg-cm, 6.9 - 12.2 in-lb)
 - When old bearing is used again, turning torque will be slightly less than the above.
 - Make sure torque is close to the specified range.

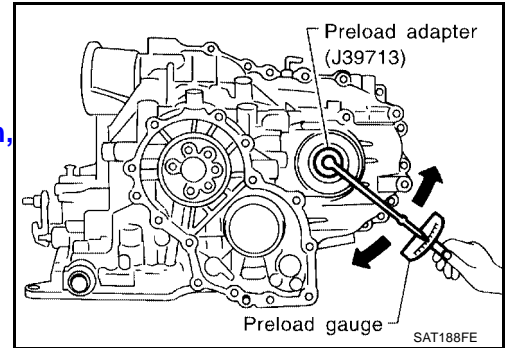

Preload adapter : RE4F04B-(J39713)

REDUCTION PINION GEAR BEARING PRELOAD

1. Remove transmission case and final drive assembly from converter housing.
2. Select proper thickness of reduction pinion gear bearing adjusting shim using the following procedures.
 - a. Place reduction pinion gear on transmission case as shown.

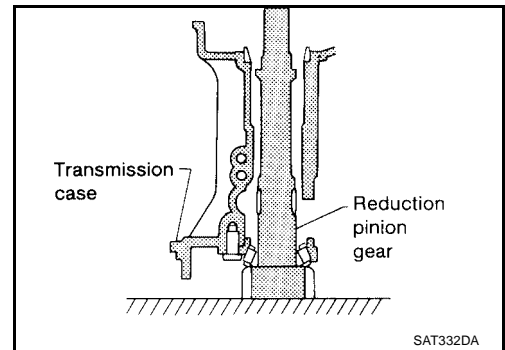

- b. Place idler gear bearing on transmission case.
 - c. Measure dimensions "B" "C" and "D" and calculate dimension "A".

$$A = D - (B + C)$$

"A"

: Distance between the surface of idler gear bearing inner race and the adjusting shim mating surface of reduction pinion gear.

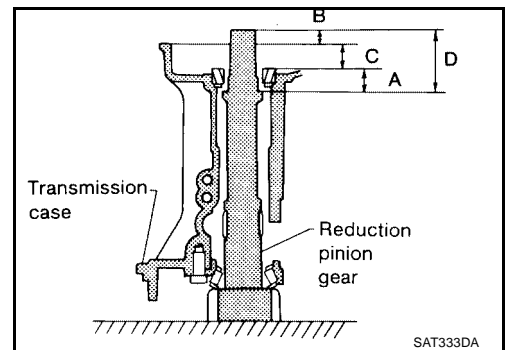

ASSEMBLY

- Measure dimension "B" between the end of reduction pinion gear and the surface of transmission case.
- **Measure dimension "B" in at least two places.**

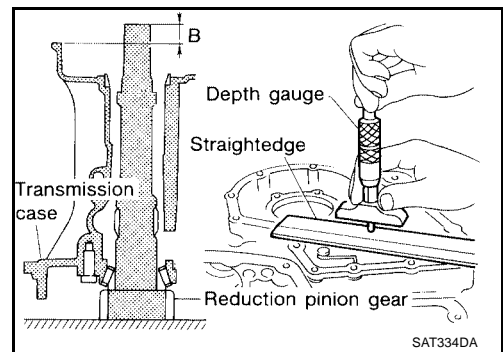

- Measure dimension "C" between the surface of idler gear bearing inner race and the surface of transmission case.
- **Measure dimension "C" in at least two places.**

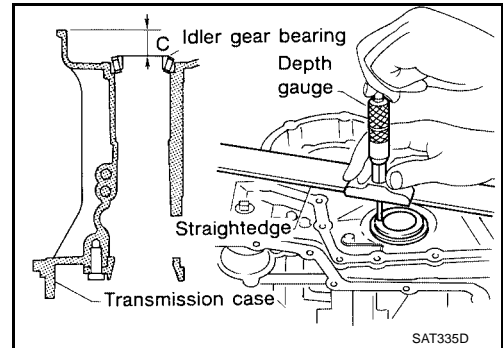

- Measure dimension "D" between the end of reduction pinion gear and the adjusting shim mating surface of reduction pinion gear.
- **Measure dimension "D" in at least two places.**
- Calculate dimension "A".

$$A = D - (B + C)$$

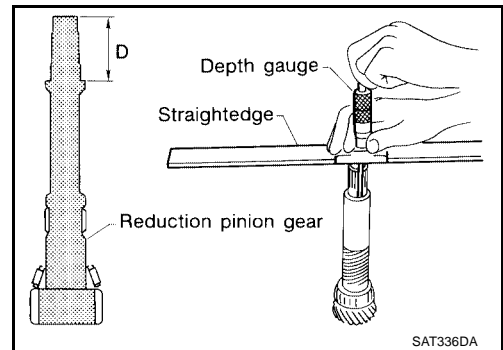

- d. Measure dimension "E" between the end of idler gear and the idler gear bearing inner race mating surface of idler gear.
- **Measure dimension "E" in at least two places.**
- e. Select proper thickness of reduction pinion gear bearing adjusting shim.

$$\text{Proper shim thickness} = A - E - 0.05 \text{ mm (0.0020 in)*}$$

(*: Bearing preload)

Reduction pinion gear bearing adjusting shim

: Refer to [AT-380](#), "[REDUCTION PINION GEAR BEARING ADJUSTING SHIMS](#)".

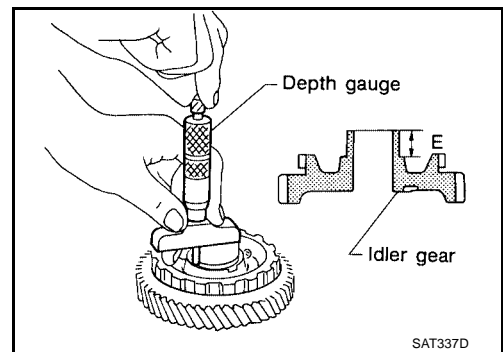

A
B
AT
D
E
F
G
H
I
J
K
L
M

ASSEMBLY

3. Install reduction gear and reduction gear bearing adjusting shim selected in step 2-e on transmission case.
4. Press idler gear bearing inner race on idler gear.
5. Press idler gear on reduction gear.
 - Press idler gear until idler gear fully contacts adjusting shim.

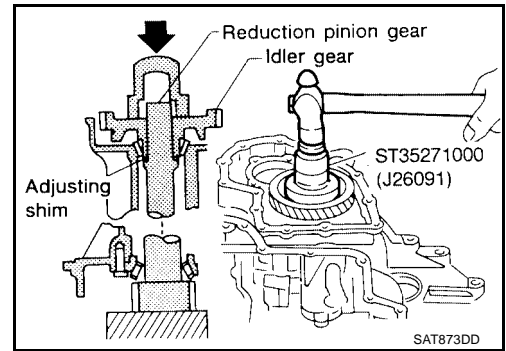

6. Tighten idler gear lock nut to the specified torque. Refer to [AT-272, "OVERHAUL"](#).
 - Lock idler gear with parking pawl when tightening lock nut.

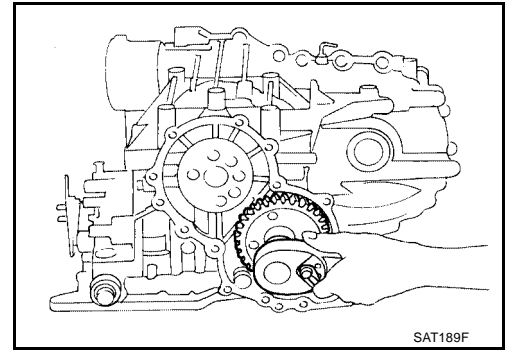

7. Measure turning torque of reduction pinion gear.
 - When measuring turning torque, turn reduction pinion gear in both directions several times to seat bearing rollers correctly.

Turning torque of reduction pinion gear : 0.05 - 0.39 N-m (0.5 - 4.0 kg-cm, 0.43 - 3.47 in-lb)

- If turning torque is out of specification, decrease or increase thickness of reduction pinion gear bearing adjusting shim.

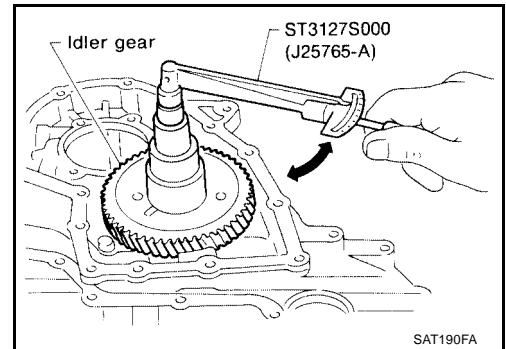

8. After properly adjusting turning torque, clinch idler gear lock nut as shown.

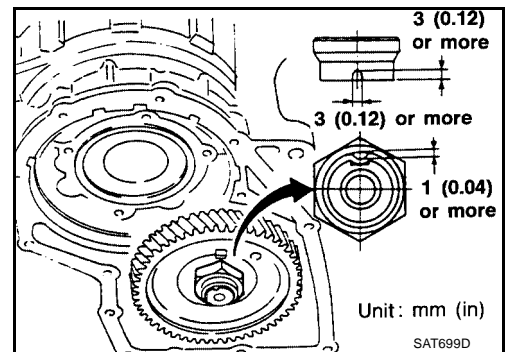

ASSEMBLY

OUTPUT SHAFT END PLAY

- Measure clearance between side cover and the end of the output shaft bearing.
- Select proper thickness of adjusting shim so that clearance is within specifications.

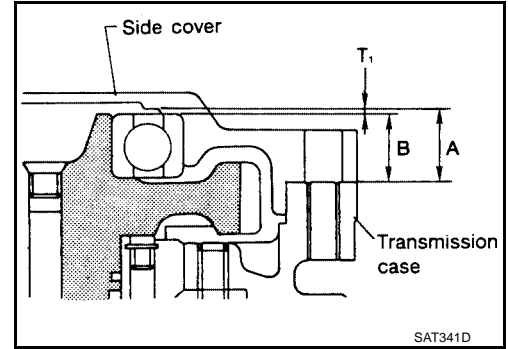

1. Install bearing retainer for output shaft.

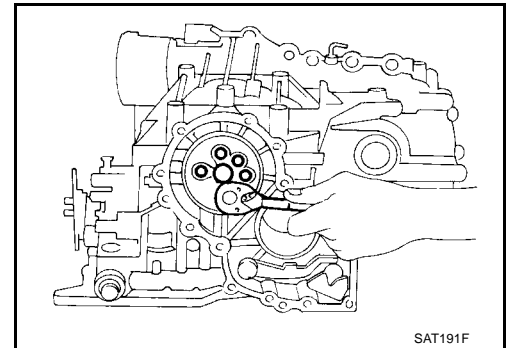

2. Install output shaft thrust needle bearing on bearing retainer.

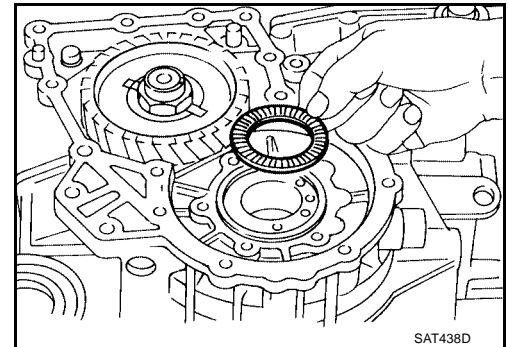

3. Install output shaft on transmission case.

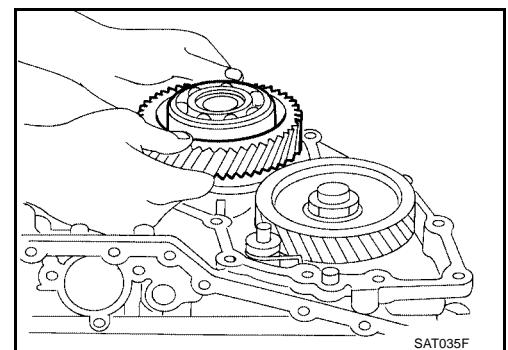

A
B
AT
D
E
F
G
H
I
J
K
L
M

ASSEMBLY

4. Measure dimensions " ℓ_1 " and " ℓ_2 " at side cover and then calculate dimension "A".

- Measure dimension " ℓ_1 " and " ℓ_2 " in at least two places.

"A" : Distance between transmission case fitting surface and adjusting shim mating surface.

$$A = \ell_1 - \ell_2$$

ℓ_2 : Height of gauge

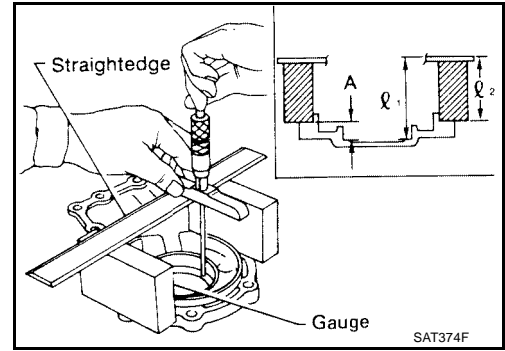

5. Measure dimensions " ℓ_2 " and " ℓ_3 " and then calculate dimension "B".

- Measure " ℓ_2 " and " ℓ_3 " in at least two places.

"B" : Distance between the end of output shaft bearing outer race and the side cover fitting surface of transmission case.

$$B = \ell_2 - \ell_3$$

ℓ_2 : Height of gauge

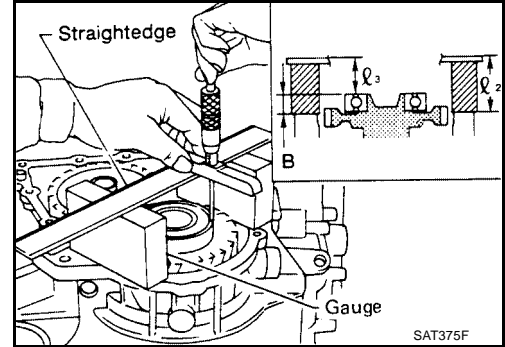

6. Select proper thickness of adjusting shim so that output shaft end play (clearance between side cover and output shaft bearing) is within specifications.

Output shaft end play (A - B) : 0 - 0.15 mm (0 - 0.0059 in)

Output shaft end play adjusting shims : Refer to [AT-381, "OUTPUT SHAFT ADJUSTING SHIMS"](#).

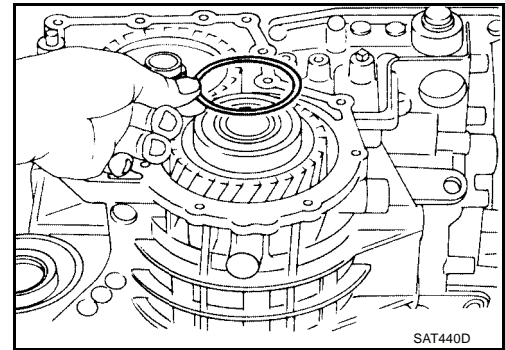

7. Install adjusting shim on output shaft bearing.

Assembly (2)

1. Apply anaerobic liquid gasket to transmission case as shown in illustration. Refer to [GI-43, "Recommended Chemical Products and Sealants"](#).

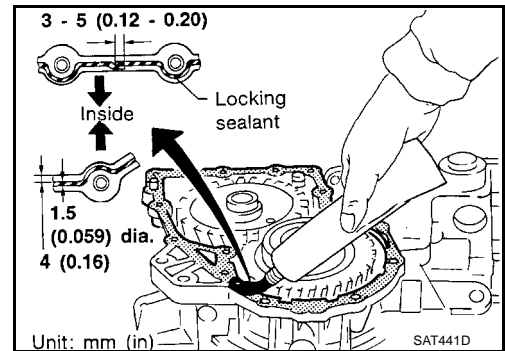

ECS006FQ

ASSEMBLY

2. Set side cover on transmission case.
 - **Apply locking sealant to the mating surface of transmission case.**

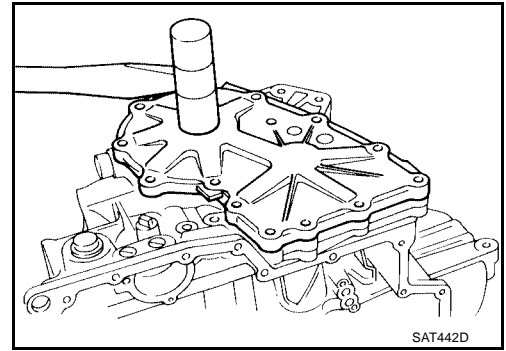

3. Tighten side cover fixing bolts to specified torque. Refer to [AT-272, "OVERHAUL"](#).
 - **Do not mix bolts A and B.**
 - **Always replace bolts A as they are self-sealing bolts.**

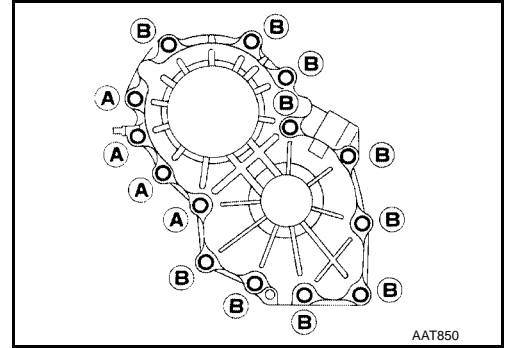

4. Remove paper rolled around bearing retainer.
5. Install thrust washer on bearing retainer.
 - **Apply petroleum jelly to thrust washer.**

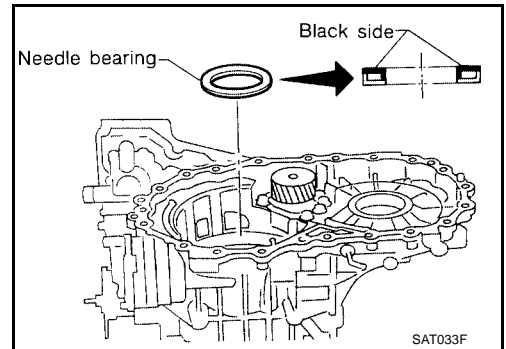

A
B
AT
D
E
F
G
H
I
J
K
L
M

ASSEMBLY

6. Install forward clutch assembly.

- **Align teeth of low & reverse brake drive plates before installing.**
- **Make sure that bearing retainer seal rings are not spread.**
- **If forward clutch assembly is correctly seated, points 1 and 2 are at almost same level.**

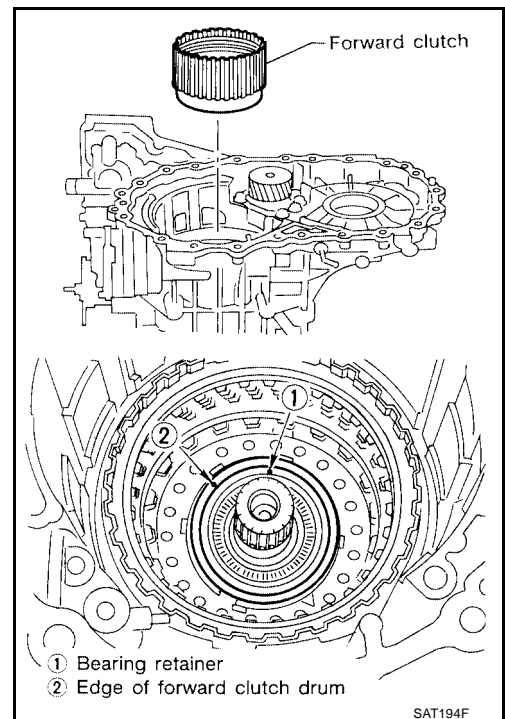

7. Install thrust needle bearing on bearing retainer.

- **Apply petroleum jelly to thrust needle bearing.**
- **Pay attention to direction of thrust needle bearing.**

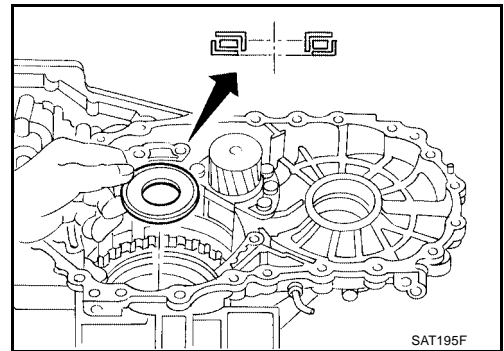

8. Install overrun clutch hub.

- **Apply petroleum jelly to thrust washers.**
- **Align teeth of overrun clutch drive plates before installing.**

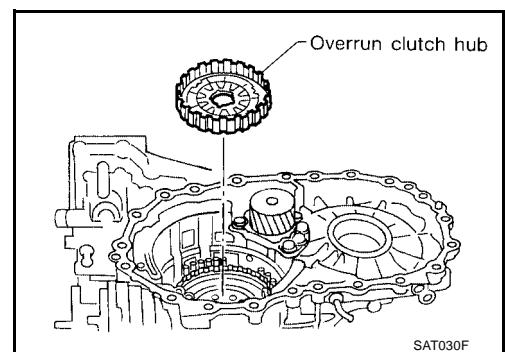

ASSEMBLY

9. Hold forward clutch hub and turn rear internal gear.
Check overrun clutch hub for correct directions of lock and unlock.
- If not shown as illustrated, check installed direction of forward one-way clutch.

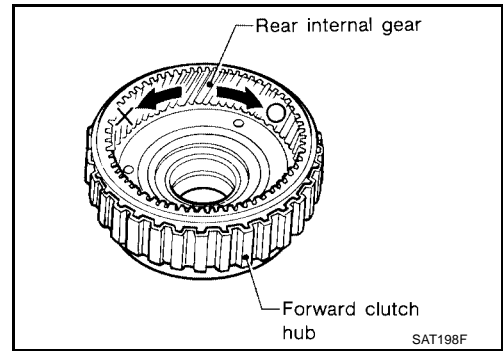

10. Install forward clutch hub and rear internal gear assembly.
- Align teeth of forward clutch drive plates before installing.
 - Check that three hooks of thrust washer are correctly aligned after installing.

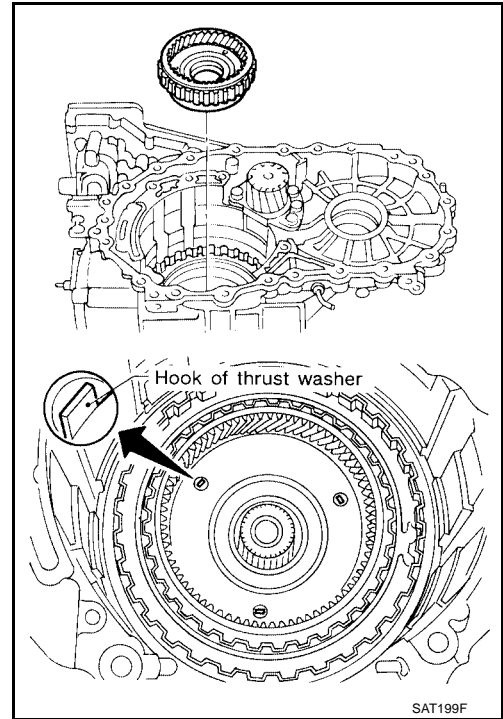

11. Install rear planetary carrier assembly and rear sun gear according to the following procedures.

- a. Install needle bearings on rear planetary carrier.
- Apply petroleum jelly to needle bearings.
 - Pay attention to direction of needle bearings.

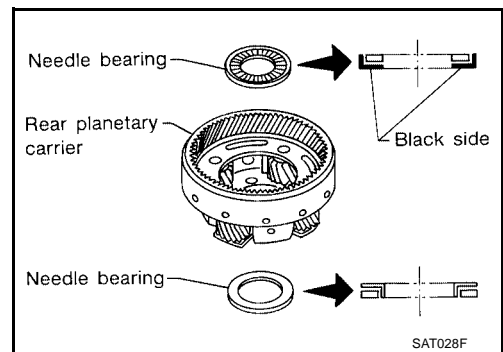

- b. Install rear sun gear on rear planetary carrier.
- Pay attention to direction of rear sun gear.

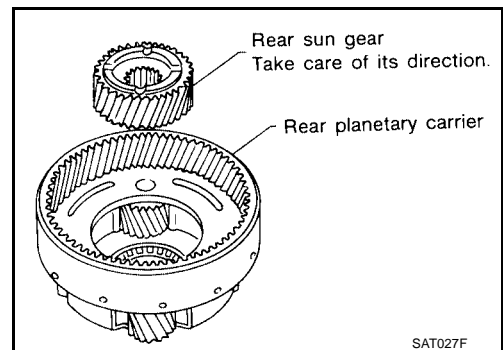

A
B
AT
D
E
F
G
H
I
J
K
L
M

ASSEMBLY

c. Install rear planetary carrier on transmission case.

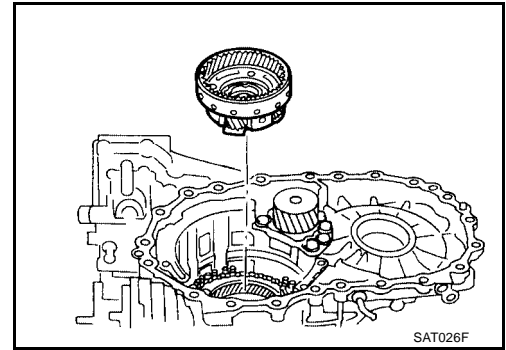

12. Install thrust needle bearing on front planetary carrier, then install them together on transmission case.

- Apply petroleum jelly to thrust needle bearing.
- Pay attention to direction of thrust needle bearing.

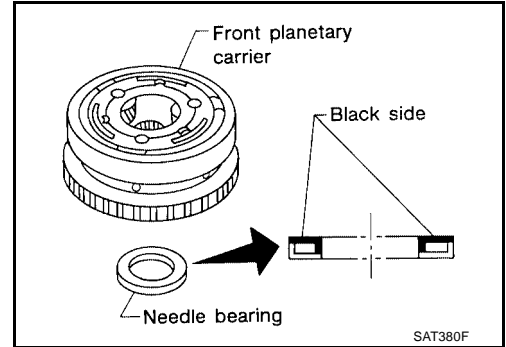

13. Install low and reverse brake piston according to the following procedures.

a. Set and align return springs to transmission case gutters as shown in illustration.

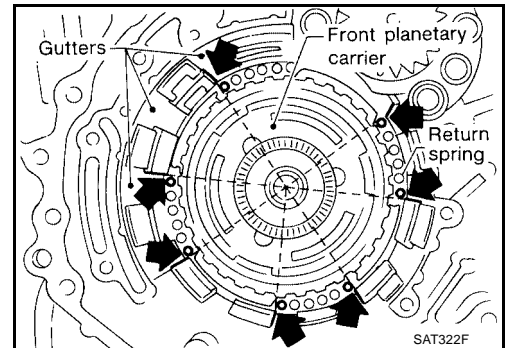

b. Set and align piston with retainer.

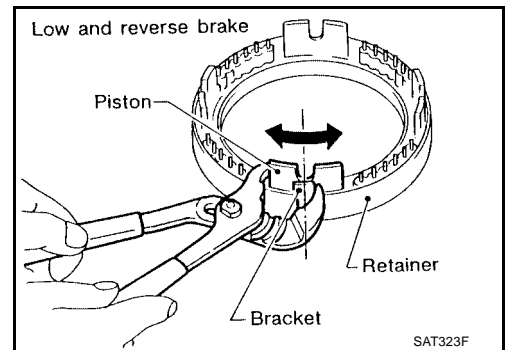

ASSEMBLY

- c. Install piston and retainer assembly on the transmission case.
- **Align bracket to specified gutter as indicated in illustration.**

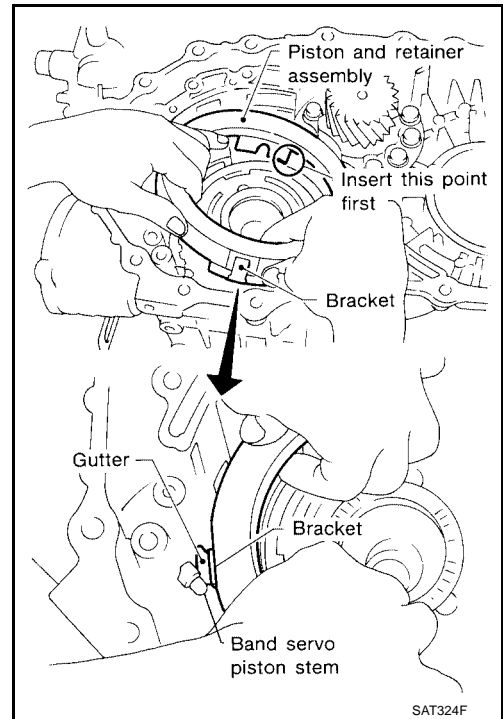

- d. Check that each protrusion of piston is correctly set to corresponding return spring as follows.
- **Push piston and retainer assembly evenly and confirm they move smoothly.**
 - **If they can not move smoothly, remove piston and retainer assembly and align return spring correctly as instructed in step "a".**

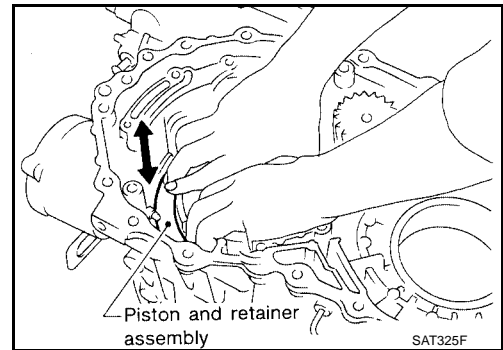

- e. Push down piston and retainer assembly and install snap ring.

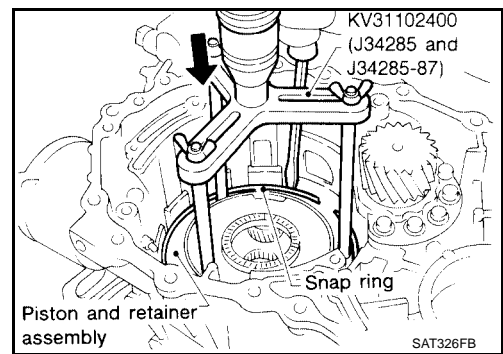

14. Install low one-way clutch to front planetary carrier by turning carrier in the direction of the arrow shown.

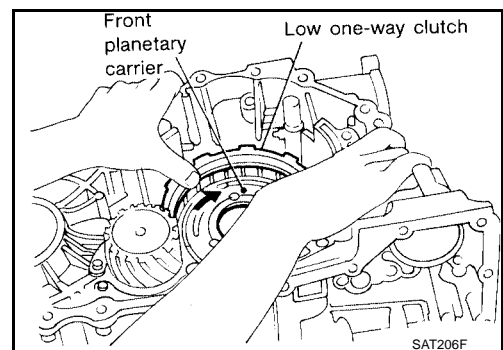

A
B
AT
D
E
F
G
H
I
J
K
L
M

ASSEMBLY

15. Install snap ring with screwdriver.

- Forward clutch and bearing must be correctly installed for snap ring to fit into groove of transmission case.

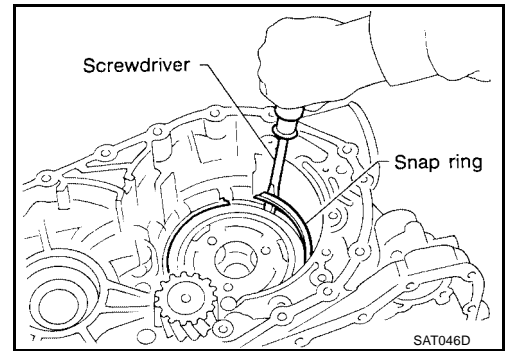

16. Install needle bearing on transmission case.

- Apply petroleum jelly to needle bearing.
- Pay attention to direction of needle bearing.

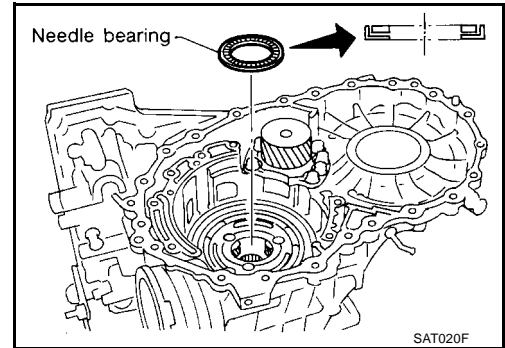

17. Install bearing race, needle bearing and high clutch hub on front sun gear.

- Apply petroleum jelly to needle bearing.
- Pay attention to direction of needle bearing.

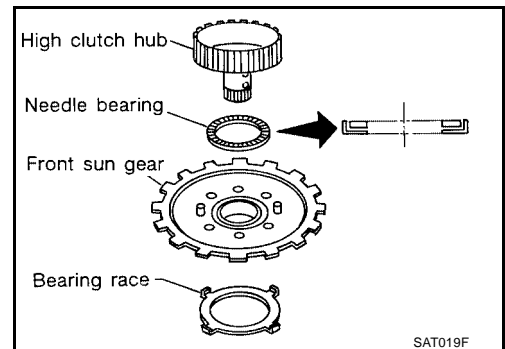

18. Install needle bearing and high clutch drum on high clutch hub.

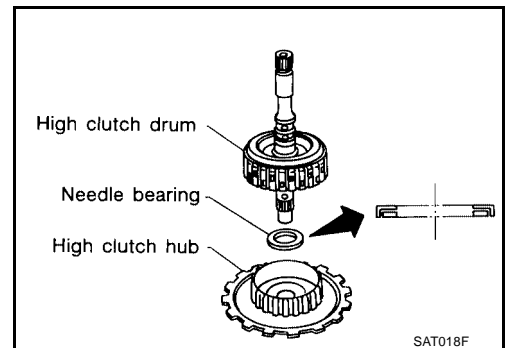

ASSEMBLY

19. Install needle bearing on high clutch drum.

- **Apply petroleum jelly to needle bearing.**
- **Pay attention to direction of needle bearing.**

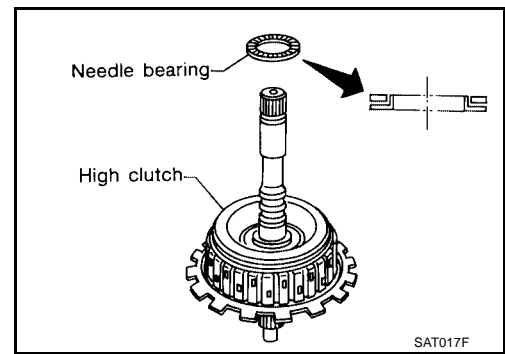

20. Remove paper rolled around input shaft.

21. Install input shaft assembly in reverse clutch.

- **Align teeth of reverse clutch drive plates before installing.**

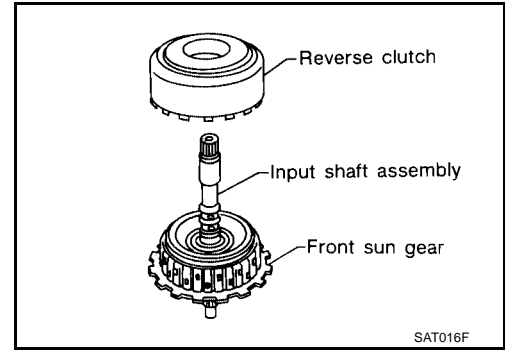

22. Install reverse clutch assembly on transmission case.

- **Align teeth of high clutch drive plates before installing.**

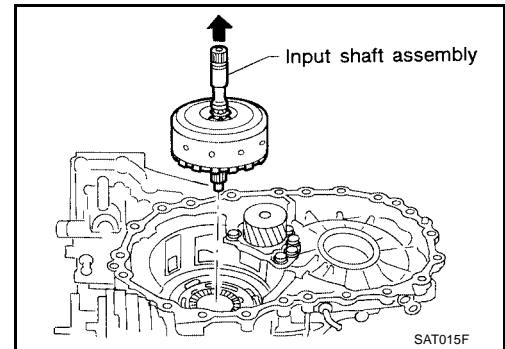

Adjustment (2)

When any parts listed below are replaced, adjust total end play and reverse clutch end play.

Part name	Total end play	Reverse clutch end play
Transmission case	●	●
Overrun clutch hub	●	●
Rear internal gear	●	●
Rear planetary carrier	●	●
Rear sun gear	●	●
Front planetary carrier	●	●
Front sun gear	●	●
High clutch hub	●	●
High clutch drum	●	●
Oil pump cover	●	●
Reverse clutch drum	—	●

ECS006FR

A
B
AT
D
E
F
G
H
I
J
K
L
M

ASSEMBLY

TOTAL END PLAY

1. Adjust total end play "T₁".

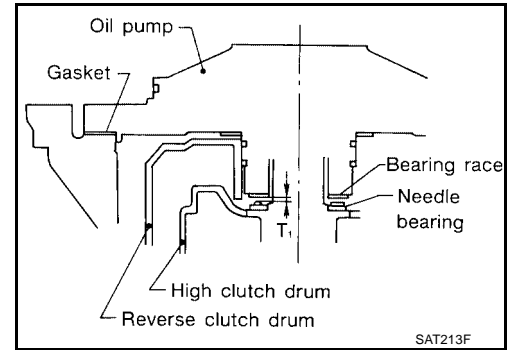

a. With original bearing race installed, place Tool onto oil pump. The long ends of legs should be placed firmly on machined surface of oil pump assembly. The gauging cylinder should rest on top of bearing race. Lock gauging cylinder in place with set screw.

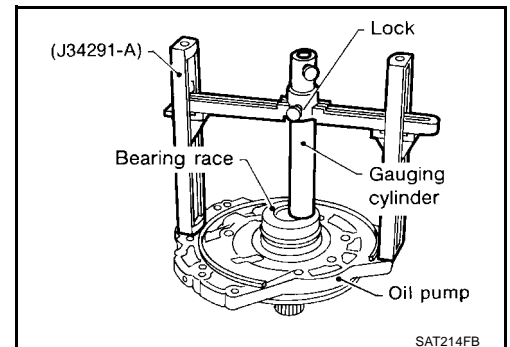

b. Install gauging plunger into cylinder.

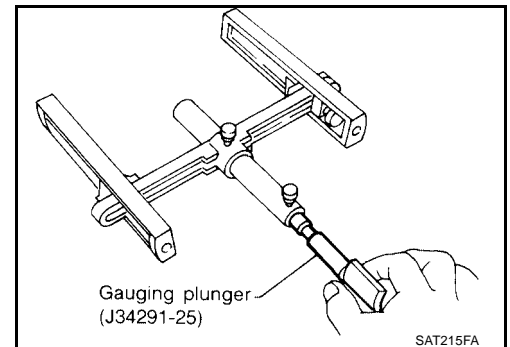

c. With needle bearing installed on high clutch drum, place Tool legs on machined surface of transmission case (with gasket). Then allow plunger to rest on needle bearing.

d. Measure gap between cylinder and plunger. This measurement should give exact total end play.

**Total end play "T₁" : 0.25 - 0.55 mm
(0.0098 - 0.0217 in)**

- If end play is out of specification, decrease or increase thickness of bearing race as necessary.

Available bearing race for adjusting total end play : Refer to [AT-381, "BEARING RACE FOR ADJUSTING TOTAL END PLAY"](#).

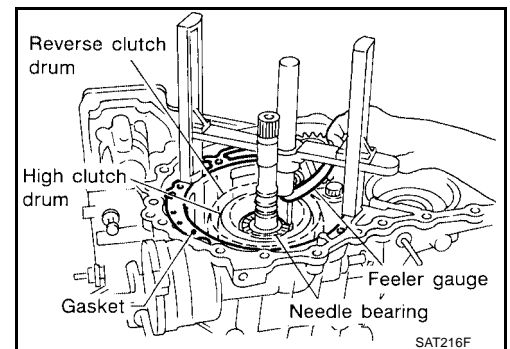

ASSEMBLY

2. Adjust reverse clutch drum end play "T₂".

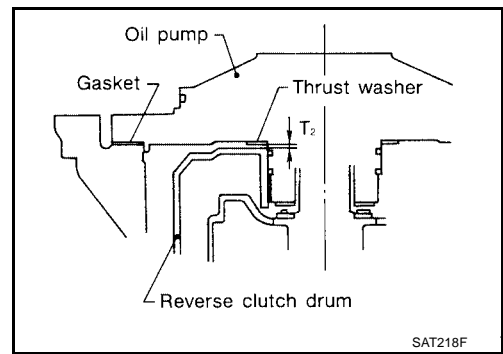

a. Place Tool on machined surface of transmission case (with gasket). Then allow gauging cylinder to rest on reverse clutch drum. Lock cylinder in place with set screw.

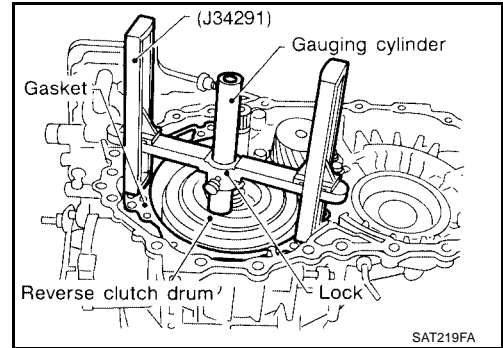

b. Install gauging plunger into cylinder.

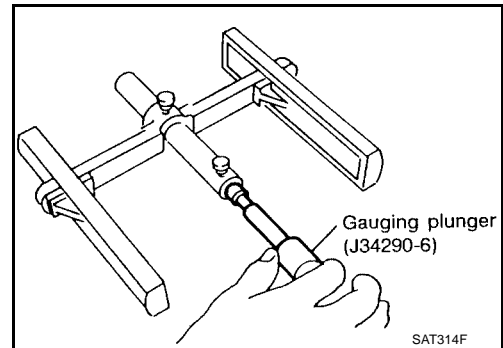

c. With original thrust washer installed on oil pump, place Tool legs onto machined surface of oil pump assembly. Then allow plunger to rest on thrust washer.

d. Measure gap between cylinder and plunger with feeler gauge. This measurement should give exact reverse clutch drum end play.

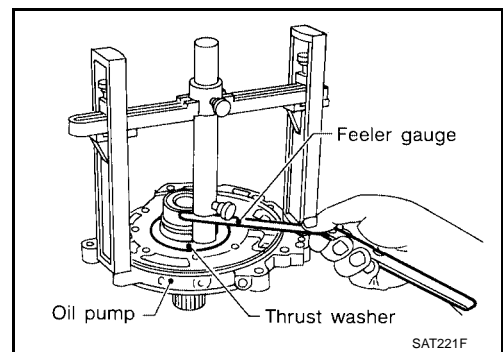

Reverse clutch drum end play "T₂" : 0.55 - 0.90 mm (0.0217 - 0.0354 in)

- If end play is out of specification, decrease or increase thickness of thrust washer as necessary.

Available thrust washer for adjusting reverse clutch drum end play : Refer to [AT-382, "THRUST WASHERS FOR ADJUSTING REVERSE CLUTCH DRUM END PLAY"](#) .

ASSEMBLY

Assembly (3)

ECS006FS

1. Install anchor end pin and lock nut on transmission case.
2. Place brake band on outside of reverse clutch drum. Tighten anchor end pin just enough so that brake band is evenly fitted on reverse clutch drum.

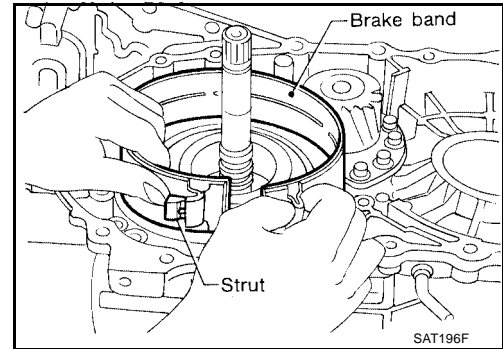

3. Place bearing race selected in total end play adjustment step on oil pump cover.
 - **Apply petroleum jelly to bearing race.**
4. Place thrust washer selected in reverse clutch end play step on reverse clutch drum.
 - **Apply petroleum jelly to thrust washer.**

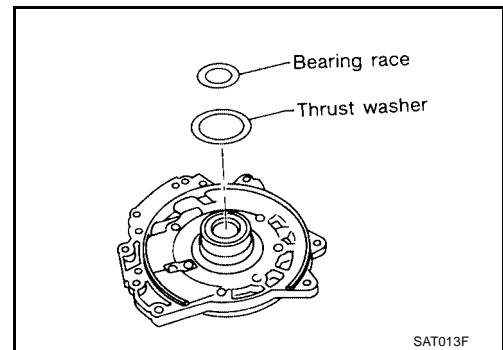

5. Install oil pump assembly, baffle plate and gasket on transmission case.
6. Tighten oil pump fixing bolts to the specified torque.

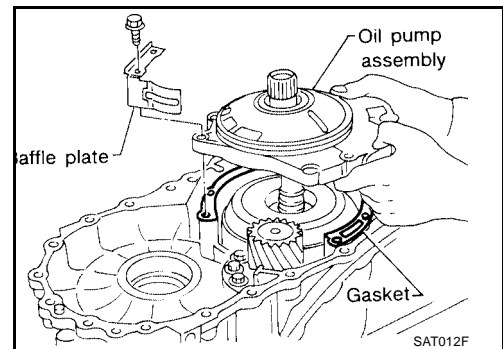

7. Install O-ring to input shaft.
 - **Apply ATF to O-ring.**

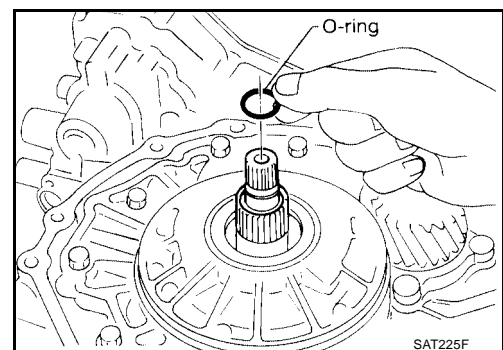

ASSEMBLY

8. Adjust brake band.
- a. Tighten anchor end pin to the specified torque.

Anchor end pin : Refer to [AT-378, "BRAKE BAND"](#) .

- b. Back off anchor end pin two and a half turns.
- c. While holding anchor end pin, tighten lock nut.

Lock nut : Refer to [AT-378, "BRAKE BAND"](#) .

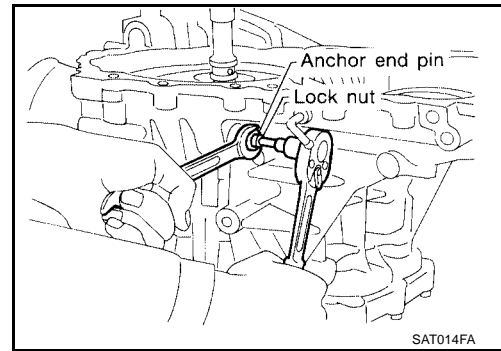

9. Apply compressed air to oil holes of transmission case and check operation of brake band.

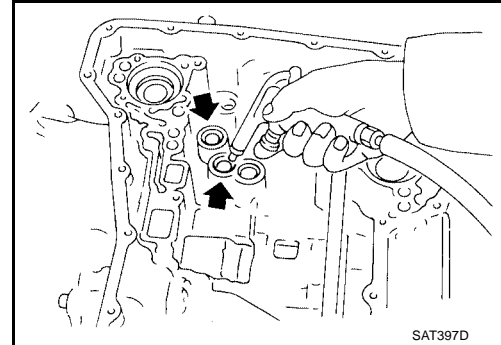

10. Install final drive assembly on transmission case.

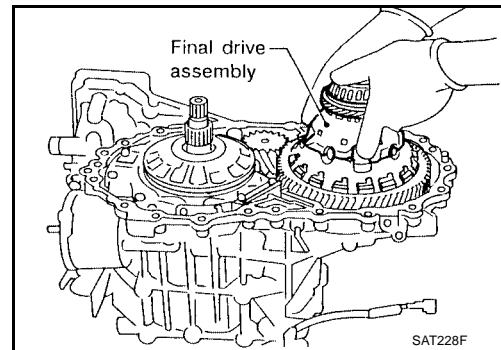

11. Install differential lubricant tube on converter housing. Tighten differential lubricant tube bolts to the specified torque. Refer to [AT-272, "OVERHAUL"](#) .

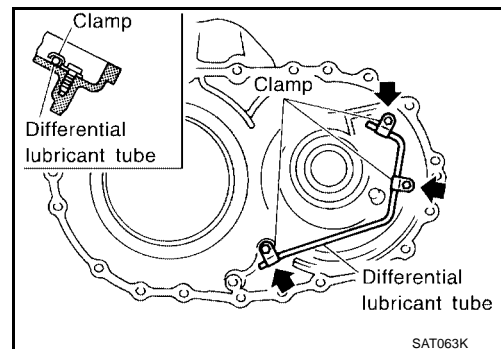

ASSEMBLY

12. Install O-ring on differential oil port of transmission case.

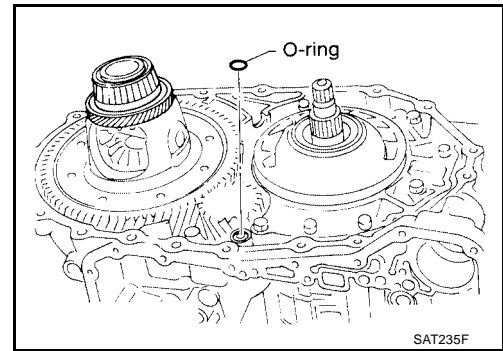

13. Install converter housing on transmission case.

- Apply locking sealant to mating surface of converter housing.

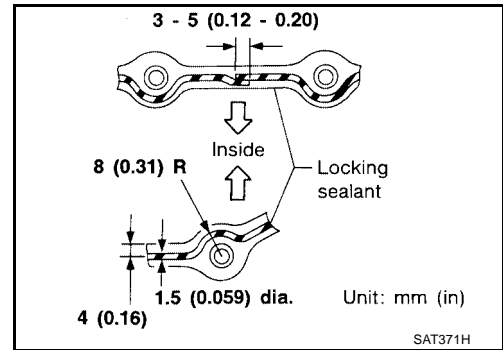

- Tighten converter housing bolts to the specified torque. Refer to [AT-272, "OVERHAUL"](#).

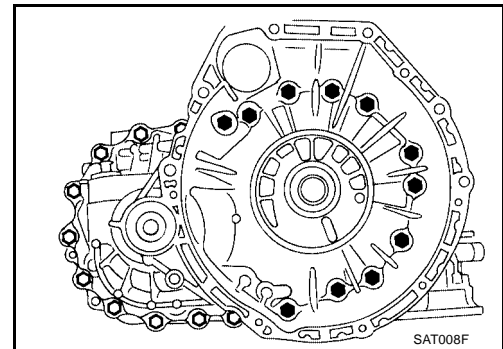

14. Install accumulator piston.

- a. Check contact surface of accumulator piston for damage.

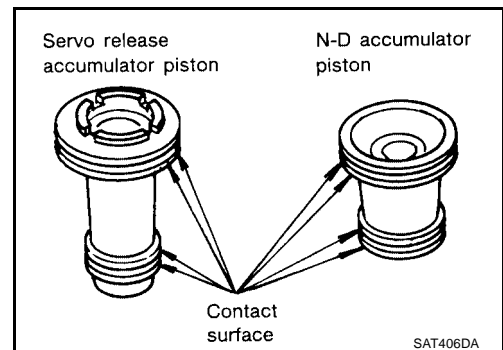

ASSEMBLY

b. Install O-rings on accumulator piston.

- **Apply ATF to O-rings.**

Accumulator piston O-rings : Refer to [AT-375, "O-RING"](#)

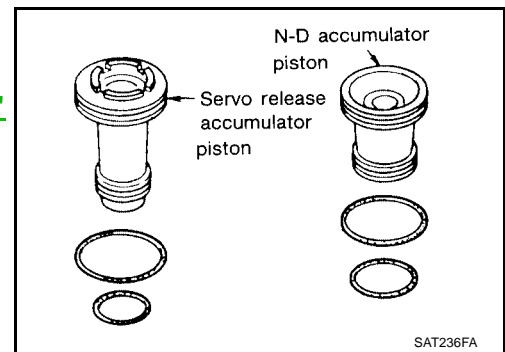

c. Install accumulator pistons and return springs on transmission case.

- **Apply ATF to inner surface of transmission case.**

Return springs : Refer to [AT-376, "RETURN SPRING"](#) .

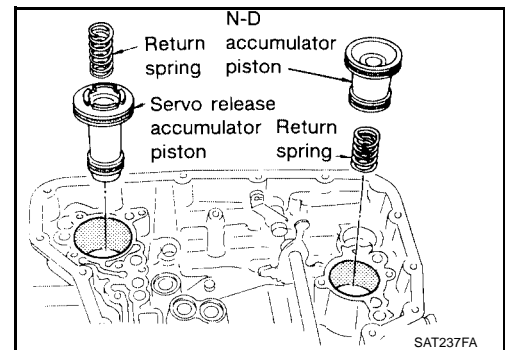

15. Install lip seals for band servo oil holes on transmission case.

- **Apply petroleum jelly to lip seals.**

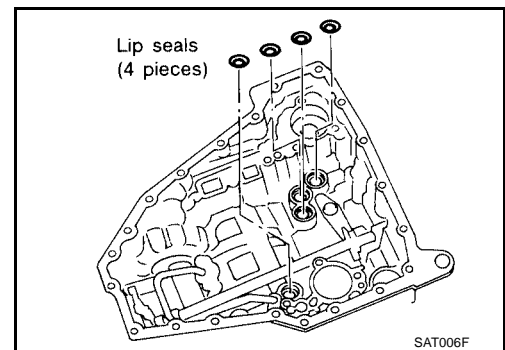

16. Install L & R oil tube and oil sleeve. Tighten L & R oil tube bolts to the specified torque. Refer to [AT-272, "OVERHAUL"](#) .

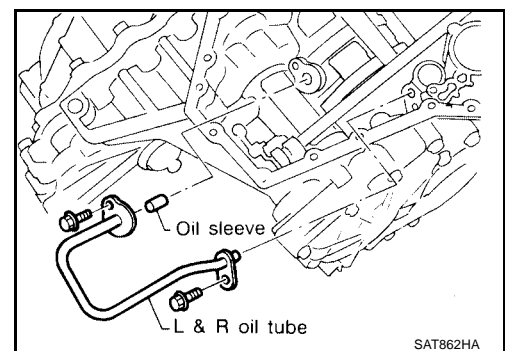

ASSEMBLY

17. Install control valve assembly.

a. Insert manual valve into control valve assembly.

- Apply ATF to manual valve.

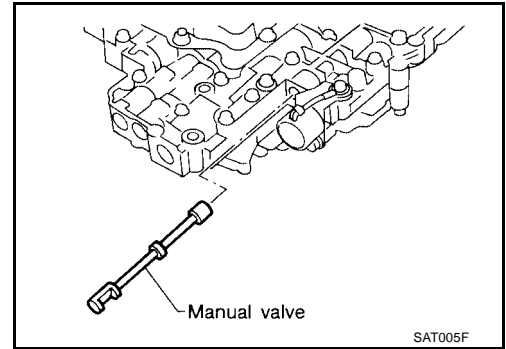

b. Set manual shaft in Neutral position.

c. Install control valve assembly on transmission case while aligning manual valve with manual plate.

d. Pass solenoid harness through transmission case and install terminal body on transmission case by pushing it.

e. Install stopper ring to terminal body.

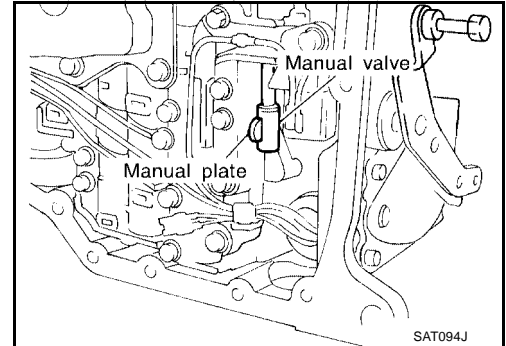

f. Tighten bolts I, X and ●.

Bolt length, number and location:

Bolt symbol	I	X	●
Bolt length "ℓ" mm (in)	40 (1.57)	33 (1.30)	43.5 (1.713)
Number of bolts	5	6	2

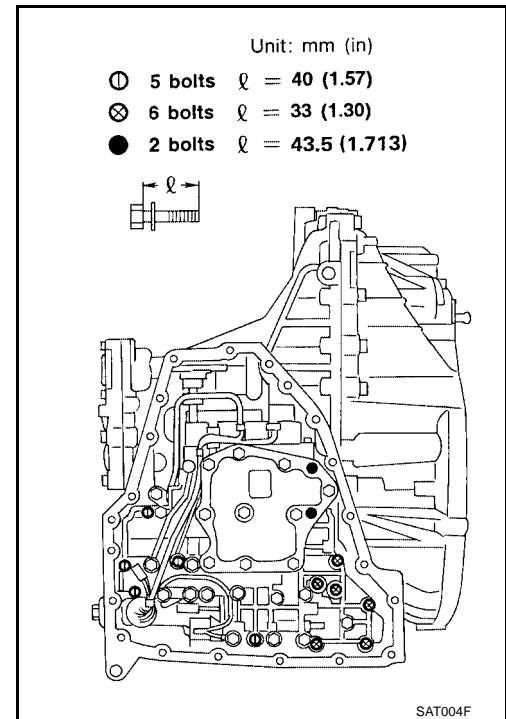

18. Install oil pan.

a. Attach a magnet to oil pan.

b. Install new oil pan gasket on transmission case.

c. Install oil pan on transmission case.

- Always replace oil pan bolts as they are self-sealing bolts.
- Tighten four bolts in a criss-cross pattern to prevent dislocation of gasket.

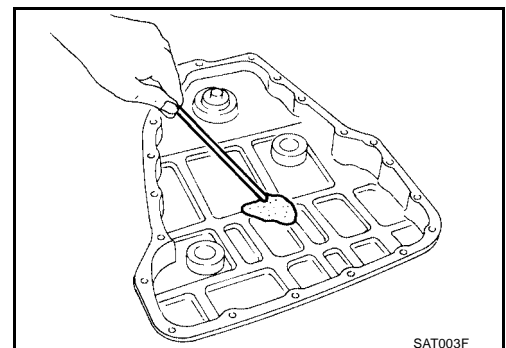

ASSEMBLY

- d. Tighten oil pan bolts and drain plug to the specified torque. Refer to [AT-272, "OVERHAUL"](#).
19. Install park/neutral position (PNP) switch.
- Set manual shaft in P position.
 - Temporarily install park/neutral position (PNP) switch on manual shaft.
 - Move selector lever to N position.

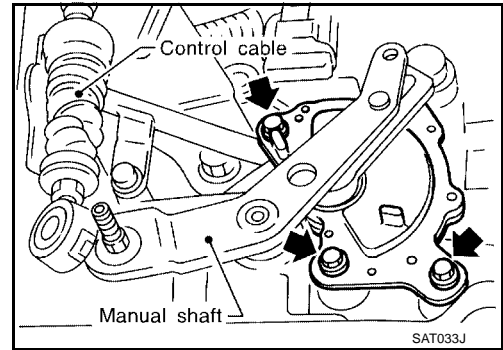

- d. Use a 4 mm (0.16 in) pin for this adjustment.
- Insert the pin straight into the manual shaft adjustment hole.
 - Rotate park/neutral position (PNP) switch until the pin can also be inserted straight into hole in park/neutral position (PNP) switch.
- e. Tighten park/neutral position (PNP) switch fixing bolts. Refer to [AT-272, "OVERHAUL"](#).
- f. Remove pin from adjustment hole after adjusting park/neutral position (PNP) switch.

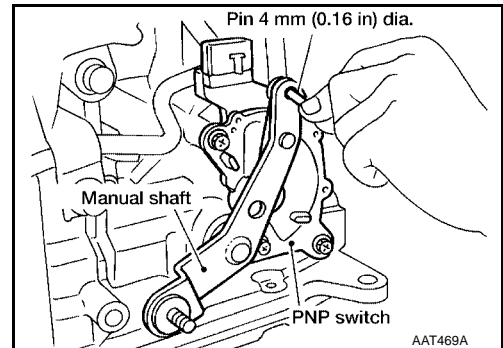

20. Install A/T fluid charging pipe and fluid cooler tube to transmission case. Tighten A/T fluid charging pipe and fluid cooler tube bolts to the specified torque. Refer to [AT-272, "OVERHAUL"](#).

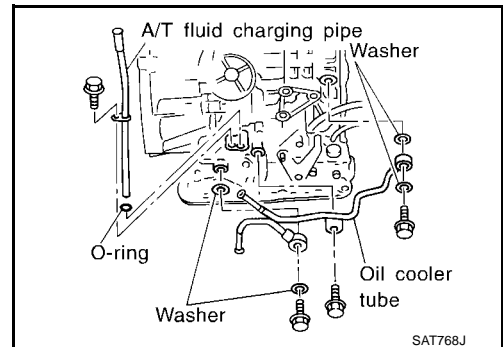

21. Install torque converter.
- Pour ATF into torque converter.
 - **Approximately 1 liter (1-1/8 US qt, 7/8 Imp qt) of fluid is required for a new torque converter.**
 - **When reusing old torque converter, add the same amount of fluid as was drained.**

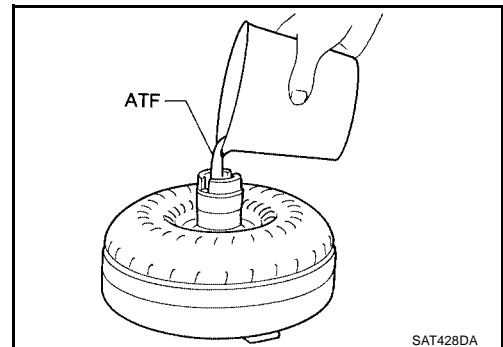

ASSEMBLY

- b. Install torque converter while aligning notches of torque converter with notches of oil pump.

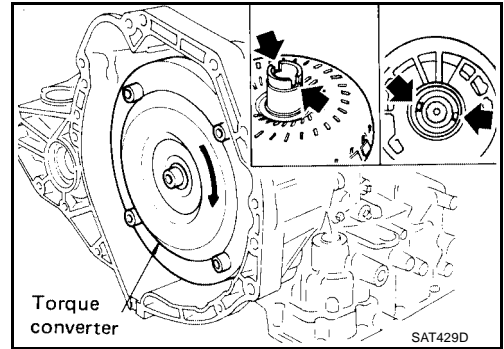

- c. Measure distance "A" to check that torque converter is in proper position.

Distance A : 14 mm (0.55 in) or more

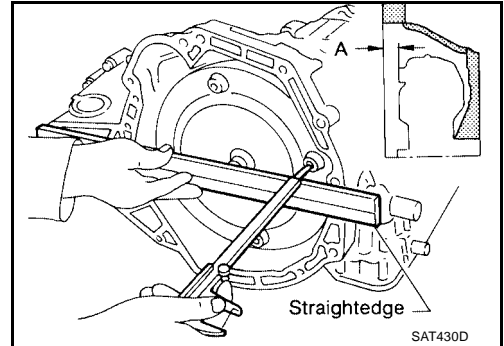

SERVICE DATA AND SPECIFICATIONS (SDS)

SERVICE DATA AND SPECIFICATIONS (SDS)

PF0:00030

General Specifications

ECS006FT

Engine		QR25DE	VQ35DE
Automatic transaxle model		RE4F04B	
Automatic transaxle assembly	Model code number	85X21	88X02
Transaxle gear ratio	1st	2.785	
	2nd	1.545	
	3rd	1.000	
	4th	0.694	
	Reverse	2.272	
	Final drive	4.087	3.789
Recommended fluid		Nissan Matic "D" (Continental U.S. and Alaska) or Canada Nissan Automatic Transmission Fluid*	
Fluid capacity ℓ (US qt, Imp qt)		9.2 (9.75, 8.125)	

*: Refer to [MA-12, "RECOMMENDED FLUIDS AND LUBRICANTS"](#).

Shift Schedule

ECS006FU

VEHICLE SPEED WHEN SHIFTING GEARS THROTTLE POSITION — QR25DE MODEL

Throttle position	Shift pattern	Vehicle speed km/h (MPH)					
		D1 → D2	D2 → D3	D3 → D4	D4 → D3	D3 → D2	D2 → D1
Full throttle	Comfort	57 - 65 (35 - 40)	106 - 114 (66 - 71)	166 - 174 (103 - 108)	162 - 170 (101 - 106)	96 - 104 (60 - 65)	41 - 49 (25 - 30)
	Auto power	57 - 65 (35 - 40)	106 - 114 (66 - 71)	166 - 174 (103 - 108)	162 - 17 (101 - 106)	96 - 104 (60 - 65)	41 - 49 (25 - 30)
Half throttle	Comfort	40 - 48 (25 - 30)	73 - 81 (45 - 50)	129 - 137 (80 - 85)	76 - 84 (47 - 52)	43 - 51 (27 - 32)	24 - 32 (15 - 20)
	Auto power	43 - 51 (27 - 32)	80 - 88 (50 - 55)	129 - 137 (80 - 85)	76 - 84 (47 - 52)	49 - 57 (30 - 35)	24 - 32 (15 - 20)

VEHICLE SPEED WHEN PERFORMING AND RELEASING LOCK-UP — QR25DE MODEL

Unit: km/h (MPH)

Selector lever position	D position		3 position	
	Comfort	Auto power	Comfort	Auto power
Lock-up "ON"	102 - 110 (63 - 68)	102 - 110 (63 - 68)	86 - 94 (53 - 58)	86 - 94 (53 - 58)
Lock-up "OFF"	86 - 94 (53 - 58)	86 - 94 (53 - 58)	83 - 91 (52 - 57)	83 - 91 (52 - 57)

NOTE:

- Lock-up vehicle speed indicates the speed in D4 position.
- Perform lock-up inspection after warming up engine.
- Lock-up vehicle speed may vary depending on the driving conditions and circumstances.

VEHICLE SPEED WHEN SHIFTING GEARS THROTTLE POSITION — VQ35DE MODEL

Throttle position	Shift pattern	Vehicle speed km/h (MPH)					
		D1 → D2	D2 → D3	D3 → D4	D4 → D3	D3 → D2	D2 → D1
Full throttle	Comfort	61 - 69 (38 - 43)	114 - 122 (71 - 76)	179 - 187 (111 - 116)	175 - 183 (109 - 114)	104 - 112 (65 - 70)	41 - 49 (25 - 30)
	Auto power	61 - 69 (38 - 43)	114 - 122 (71 - 76)	179 - 187 (111 - 116)	175 - 183 (109 - 114)	104 - 112 (65 - 70)	41 - 49 (25 - 30)

SERVICE DATA AND SPECIFICATIONS (SDS)

Throttle position	Shift pattern	Vehicle speed km/h (MPH)					
		D1 → D2	D2 → D3	D3 → D4	D4 → D3	D3 → D2	D2 → D1
Half throttle	Comfort	39 - 47 (24 - 28)	73 - 81 (45 - 50)	137 - 145 (85 - 90)	87 - 95 (54 - 59)	33 - 41 (21 - 25)	9 - 17 (6 - 11)
	Auto power	45 - 53 (28 - 33)	86 - 94 (53 - 58)	137 - 145 (85 - 90)	87 - 95 (54 - 59)	51 - 59 (32 - 37)	9 - 17 (6 - 11)

VEHICLE SPEED WHEN PERFORMING AND RELEASING LOCK-UP — VQ35DE MODEL

Unit: km/h (MPH)

Selector lever position	D position		3 position	
Shift pattern	Comfort	Auto power	Comfort	Auto power
Lock-up "ON"	109 - 117 (68 - 73)	109 - 117 (68 - 73)	86 - 94 (53 - 58)	86 - 94 (53 - 58)
Lock-up "OFF"	74 - 82 (46 - 51)	74 - 82 (46 - 51)	83 - 91 (52 - 57)	83 - 91 (52 - 57)

NOTE:

- Lock-up vehicle speed indicates the speed in D4 position.
- Perform lock-up inspection after warming up engine.
- Lock-up vehicle speed may vary depending on the driving conditions and circumstances.

Stall Revolution

ECS006FV

Engine	Stall revolution rpm
QR25DE	2,350 - 2,800
VQ35DE	2,550 - 3,050

Line Pressure

ECS006FW

Engine speed rpm	Line pressure kPa (kg/cm ² , psi)			
	D, 2 and 1 positions		R position	
	QR25DE	VQ35DE	QR25DE	VQ35DE
Idle	500 (5.1, 73)		778 (7.9, 113)	
Stall	1,223 (12.6, 179)		1,918 (19.6, 278)	

Control Valves

ECS006FX

CONTROL VALVE AND PLUG RETURN SPRINGS

Unit: mm (in)

	Parts	Item			
		Part No.*	Free length	Outer diameter	
Upper body	23	Pilot valve spring	31742-80L13	38.98 (1.535)	8.9 (0.350)
	7	1-2 accumulator valve spring	31742-80L15	20.5 (0.807)	6.95 (0.274)
	28	1-2 accumulator piston spring	31742-80L14	55.26 (2.176)	19.6 (0.772)
			31742-80L17**	55.7 (2.193)	19.5 (0.768)
	33	1st reducing valve spring	31742-80L08	27.0 (1.063)	7.0 (0.276)
	35	3-2 timing valve spring	31736-01X00	23.0 (0.906)	6.65 (0.262)
	18	Overrun clutch reducing valve spring	31742-80L09	37.5 (1.476)	6.9 (0.272)
	16	Torque converter relief valve spring	31742-80L10	31.0 (1.220)	9.0 (0.354)
	11	Torque converter clutch control valve	31742-80L16	56.98 (2.243)	6.5 (0.256)
3	Cooler check valve spring	31742-85X01	29.4 (1.157)	6.0 (0.236)	

SERVICE DATA AND SPECIFICATIONS (SDS)

Parts			Item		
			Part No.*	Free length	Outer diameter
Lower body	15	Pressure regulator valve spring	31742-80L01	45.0 (1.772)	15.0 (0.591)
	20	Overrun clutch control valve spring	31762-80L00	21.7 (0.854)	7.0 (0.276)
	24	Accumulator control valve spring	31742-80L02	22.0 (0.866)	6.5 (0.256)
	29	Shift valve A spring	31762-80L00	21.7 (0.854)	7.0 (0.276)
	32	Shuttle valve spring	31762-41X04	51.0 (2.008)	5.65 (0.222)
	12	Shift valve B spring	31762-80L00	21.7 (0.854)	7.0 (0.276)
	7	Pressure modifier valve spring	31742-80L13	30.5 (1.201)	9.8 (0.386)
	3		31742-80L04	32.0 (1.260)	6.9 (0.272)
	—	Oil cooler relief valve spring	31742-80L12	17.02 (0.670)	8.0 (0.315)

*: Always check with the Parts Department for the latest parts information.

**: This part is for model code number "88X02".

Accumulator O-RING

ECS006FY

Unit: mm (in)

Accumulator	Part No.*	Inner diameter (Small)	Part No.*	Inner diameter (Large)
Servo release accumulator	31526-41X03	26.9 (1.059)	31526-41X02	44.2 (1.740)
N-D accumulator	31526-31X08	34.6 (1.362)	31672-21X00	39.4 (1.551)

*: Always check with the Parts Department for the latest parts information.

SERVICE DATA AND SPECIFICATIONS (SDS)

RETURN SPRING

Unit: mm (in)

Accumulator	Part number*	Free length	Outer diameter
Servo release accumulator	31605-85X00	62.8 (2.473)	21 (0.827)
N-D accumulator	31605-80L03	43.5 (1.713)	28.0 (1.102)

*: Always check with the Parts Department for the latest parts information.

Clutch and Brakes REVERSE CLUTCH

ECS006FZ

Model code number		85X21 and 88X02	
Number of drive plates		2	
Number of driven plates		2	
Drive plate thickness mm (in)	Standard	1.6 (0.063)	
	Allowable limit	1.4 (0.055)	
Driven plate thickness mm (in)		Standard 1.8 (0.070)	
Clearance mm (in)	Standard	0.5 - 0.8 (0.020 - 0.031)	
	Allowable limit	1.2 (0.047)	
Thickness of retaining plates		Thickness mm (in)	Part number*
		6.6 (0.260)	31537-80L00
		6.8 (0.268)	31537-80L01
		7.0 (0.276)	31537-80L02
		7.2 (0.283)	31537-80L03
		7.4 (0.291)	31537-80L04
		7.6 (0.299)	31537-80L05
		7.8 (0.307)	31537-80L06

*: Always check with the Parts Department for the latest parts information.

HIGH CLUTCH — QR25DE MODEL

Model code number		85X21	
Number of drive plates		3	
Number of driven plates		7*2 + 1*3	
Drive plate thickness mm (in)	Standard	1.6 (0.063)	
	Allowable limit	1.4 (0.055)	
Driven plate thickness mm (in)	Standard	*2	*3
		1.4 (0.055)	2.0 (0.079)
Clearance mm (in)	Standard	1.8 - 2.2 (0.071 - 0.087)	
	Allowable limit	2.8 (0.110)	
Thickness of retaining plates		Thickness mm (in)	Part number*
		3.2 (0.126)	31537-80L20
		3.4 (0.134)	31537-80L21
		3.6 (0.142)	31537-80L22
		3.8 (0.150)	31537-80L23
		4.0 (0.157)	31537-80L24

*: Always check with the Parts Department for the latest parts information.

HIGH CLUTCH — VQ35DE MODEL

Model code number		88X02	
Number of drive plates		4	
Number of driven plates		6*4 + 1*5	
Drive plate thickness mm (in)	Standard	1.6 (0.063)	
	Allowable limit	1.4 (0.055)	

SERVICE DATA AND SPECIFICATIONS (SDS)

Driven plate thickness mm (in)	Standard	*4	*5
		1.4 (0.055)	2.0 (0.079)
Clearance mm (in)	Standard	1.8 - 2.2 (0.071 - 0.087)	
	Allowable limit	2.8 (0.110)	
Thickness of retaining plates	Thickness mm (in)		Part number*
	3.0 (0.118)		31537-80L19
	3.2 (0.126)		31537-80L20
	3.4 (0.134)		31537-80L21
	3.6 (0.142)		31537-80L22
	3.8 (0.150)		31537-80L23

*: Always check with the Parts Department for the latest parts information.

FORWARD CLUTCH

Model code number	85X21		88X02
Number of drive plates	5		6
Number of driven plates	5		6
Drive plate thickness mm (in)	Standard	1.6 (0.063)	
	Allowable limit	1.4 (0.055)	
Driven plate thickness mm (in)	Standard	1.8 (0.071)	
Clearance mm (in)	Standard	0.45 - 0.85 (0.0177 - 0.0335)	
	Allowable limit	1.85 (0.0728)	
Thickness of retaining plates	Thickness mm (in)		Part number*
	3.2 (0.126)		31537-80L18
	3.4 (0.134)		31537-80L17
	3.6 (0.142)		31537-80L12
	3.8 (0.150)		31537-80L13
	4.0 (0.157)		31537-80L14
	4.2 (0.165)		31537-80L15
4.4 (0.173)		31537-80L16	

*: Always check with the Parts Department for the latest parts information.

OVERRUN CLUTCH

Model code number	85X21 and 88X02		
Number of drive plates	3		
Number of driven plates	5		
Drive plate thickness mm (in)	Standard	1.6 (0.063)	
	Allowable limit	1.4 (0.055)	
Driven plate thickness mm (in)	Standard	1.8 (0.071)	
Clearance mm (in)	Standard	0.7 - 1.1 (0.028 - 0.043)	
	Allowable limit	1.7 (0.067)	
Thickness of retaining plates	Thickness mm (in)		Part number*
	3.0 (0.118)		31537-80L07
	3.2 (0.126)		31537-80L08
	3.4 (0.134)		31537-80L09
	3.6 (0.142)		31537-80L10
	3.8 (0.150)		31537-80L11

*: Always check with the Parts Department for the latest parts information.

LOW & REVERSE BRAKE

Model code number	85X21	88X02
Number of drive plates	6	7
Number of driven plates	6	7 + 1

SERVICE DATA AND SPECIFICATIONS (SDS)

Drive plate thickness mm (in)	Standard	1.8 (0.071)
	Allowable limit	1.6 (0.063)
Driven plate thickness mm (in)	Standard	1.8 (0.071)
Clearance mm (in)	Standard	1.7 - 2.1 (0.067 - 0.083)
	Allowable limit	3.3 (0.130)
Thickness of retaining plates	Thickness mm (in)	Part number*
	2.0 (0.079)	31667-80L00
	2.2 (0.087)	31667-80L01
	2.4 (0.094)	31667-80L02
	2.6 (0.102)	31667-80L03
	2.8 (0.110)	31667-80L04
	3.0 (0.118)	31667-80L05
	3.2 (0.126)	31667-80L06
3.4 (0.134)	31667-80L07	

*: Always check with the Parts Department for the latest parts information.

CLUTCH AND BRAKE RETURN SPRINGS

Unit: mm (in)

Parts	Part number*	Free length	Outer diameter
Forward clutch (Overrun clutch) (22 pcs)	31505-80L00	21.4 (0.843)	10.3 (0.406)
High clutch (10 pcs)	31505-80L02	22.5 (0.886)	10.8 (0.425)
Low & reverse brake (24 pcs)	31505-80L01	24.1 (0.949)	6.6 (0.260)

*: Always check with the Parts Department for the latest parts information.

BRAKE BAND

Anchor end pin tightening torque N-m (kg-m, in-lb)	4.0 - 5.8 (0.4 - 0.6, 36 - 52)
Number of returning revolutions for anchor end pin	2.5
Lock nut tightening torque N-m (kg-m, ft-lb)	31 - 36 (3.2 - 3.7, 23 - 27)

Final Drive DIFFERENTIAL SIDE GEAR CLEARANCE

ECS006G0

Clearance between side gear and differential case with washer mm (in)	0.1 - 0.2 (0.004 - 0.008)
---	---------------------------

DIFFERENTIAL SIDE GEAR THRUST WASHERS

Thickness mm (in)	Part number*
0.75 (0.0295)	38424-81X00
0.80 (0.0315)	38424-81X01
0.85 (0.0335)	38424-81X02
0.90 (0.0354)	38424-81X03
0.95 (0.0374)	38424-81X04

*: Always check with the Parts Department for the latest parts information.

SERVICE DATA AND SPECIFICATIONS (SDS)

DIFFERENTIAL SIDE BEARING PRELOAD ADJUSTING SHIMS

Thickness mm (in)	Part number*
0.48 (0.0189)	31438-80X00
0.52 (0.0205)	31438-80X01
0.56 (0.0220)	31438-80X02
0.60 (0.0236)	31438-80X03
0.64 (0.0252)	31438-80X04
0.68 (0.0268)	31438-80X05
0.72 (0.0283)	31438-80X06
0.76 (0.0299)	31438-80X07
0.80 (0.0315)	31438-80X08
0.84 (0.0331)	31438-80X09
0.88 (0.0346)	31438-80X10
0.92 (0.0362)	31438-80X11

*: Always check with the Parts Department for the latest parts information.

BEARING PRELOAD

Differential side bearing preload mm (in)	0.05 - 0.09 (0.0020 - 0.0035)
---	-------------------------------

TURNING TORQUE

Turning torque of final drive assembly N-m (kg-cm, in-lb)	0.78 - 1.37 (8.0 - 14.0, 6.9 - 12.2)
---	--------------------------------------

Planetary Carrier and Oil Pump PLANETARY CARRIER

ECS006G1

Clearance between planetary carrier and pinion washer mm (in)	Standard	0.20 - 0.70 (0.0079 - 0.0276)
	Allowable limit	0.80 (0.0315)

OIL PUMP

Oil pump side clearance mm (in)	0.030 - 0.050 (0.0012 - 0.0020)	
Thickness of inner gears and outer gears	Inner gear	
	Thickness mm (in)	Part number*
	11.99 - 12.0 (0.4720 - 0.4724)	31346-80L00
	11.98 - 11.99 (0.4717 - 0.4720)	31346-80L01
	11.97 - 11.98 (0.4713 - 0.4717)	31346-80L02
	Outer gear	
	Thickness mm (in)	Part number*
	11.99 - 12.0 (0.4720 - 0.4724)	31347-80L00
11.98 - 11.99 (0.4717 - 0.4720)	31347-80L01	
11.97 - 11.98 (0.4713 - 0.4717)	31347-80L02	
Clearance between oil pump housing and outer gear mm (in)	Standard	0.111 - 0.181 (0.0044 - 0.0071)
	Allowable limit	0.181 (0.0071)
Oil pump cover seal ring clearance mm (in)	Standard	0.1 - 0.25 (0.0039 - 0.0098)
	Allowable limit	0.25 (0.0098)

*: Always check with the Parts Department for the latest parts information.

Input Shaft SEAL RING CLEARANCE

ECS006G2

Input shaft seal ring clearance mm (in)	Standard	0.08 - 0.23 (0.0031 - 0.0091)
	Allowable limit	0.23 (0.0091)

SEAL RING

Outer diameter mm (in)	Inner diameter mm (in)	Width mm (in)	Part number*
26 (1.024)	22.4 (0.882)	1.971 (0.078)	31525-80X02

*: Always check with the Parts Department for the latest parts information.

SERVICE DATA AND SPECIFICATIONS (SDS)

Reduction Pinion Gear TURNING TORQUE

ECS006G3

Turning torque of reduction pinion gear N-m (kg-cm, in-lb)	0.05 - 0.39 (0.5 - 4.0, 0.43 - 3.47)
--	--------------------------------------

REDUCTION PINION GEAR BEARING ADJUSTING SHIMS

NO.	Thickness mm (in)	Part number	NO.	Thickness mm (in)	Part number*
1	5.00 (0.1969)	31439-81X00	18	5.34 (0.2102)	31439-81X17
2	5.02 (0.1976)	31439-81X01	19	5.36 (0.2110)	31439-81X18
3	5.04 (0.1984)	31439-81X02	20	5.38 (0.2118)	31439-81X19
4	5.06 (0.1992)	31439-81X03	21	5.40 (0.2126)	31439-81X20
5	5.08 (0.2000)	31439-81X04	22	5.42 (0.2134)	31439-81X21
6	5.10 (0.2008)	31439-81X05	23	5.44 (0.2142)	31439-81X22
7	5.12 (0.2016)	31439-81X06	24	5.46 (0.2150)	31439-81X23
8	5.14 (0.2024)	31439-81X07	25	5.48 (0.2157)	31439-81X24
9	5.16 (0.2031)	31439-81X08	26	5.50 (0.2165)	31439-81X46
10	5.18 (0.2039)	31439-81X09	27	5.52 (0.2173)	31439-81X47
11	5.20 (0.2047)	31439-81X10	28	5.54 (0.2181)	31439-81X48
12	5.22 (0.2055)	31439-81X11	29	5.56 (0.2189)	31439-81X49
13	5.24 (0.2063)	31439-81X12	30	5.58 (0.2197)	31439-81X60
14	5.26 (0.2071)	31439-81X13	31	5.60 (0.2205)	31439-81X61
15	5.28 (0.2079)	31439-81X14	32	5.62 (0.2213)	31439-81X62
16	5.30 (0.2087)	31439-81X15	33	5.64 (0.2220)	31439-81X63
17	5.32 (0.2094)	31439-81X16	34	5.66 (0.2228)	31439-81X64
35	5.68 (0.2236)	31439-81X65	50	4.70 (0.1850)	31439-83X06
36	5.70 (0.2244)	31439-81X66	51	4.72 (0.1858)	31439-83X11
37	5.72 (0.2252)	31439-81X67	52	4.74 (0.1866)	31439-83X12
38	5.74 (0.2260)	31439-81X68	53	4.76 (0.1874)	31439-83X13
39	5.76 (0.2268)	31439-81X69	54	4.78 (0.1882)	31439-83X14
40	5.78 (0.2276)	31439-81X70	55	4.80 (0.1890)	31439-83X15
41	5.80 (0.2283)	31439-81X71	56	4.82 (0.1898)	31439-83X16
42	5.82 (0.2291)	31439-81X72	57	4.84 (0.1906)	31439-83X17
43	5.84 (0.2299)	31439-81X73	58	4.86 (0.1913)	31439-83X18
44	5.86 (0.2307)	31439-81X74	59	4.88 (0.1921)	31439-83X19
45	4.60 (0.1811)	31439-85X01	60	4.90 (0.1929)	31439-83X20
46	4.62 (0.1819)	31439-85X02	61	4.92 (0.1937)	31439-83X21
47	4.64 (0.1827)	31439-85X03	62	4.94 (0.1945)	31439-83X22
48	4.66 (0.1835)	31439-85X04	63	4.96 (0.1953)	31439-83X23
49	4.68 (0.1843)	31439-85X05	64	4.98 (0.1961)	31439-83X24

*: Always check with the Parts Department for the latest parts information.

Band Servo RETURN SPRING

ECS006G4

Unit: mm (in)

Return spring	Part number*	Free length	Outer diameter
2nd servo return spring	31605-80L05	32.5 (1.280)	25.9 (1.020)
OD servo return spring	31605-80L06	62.6 (2.465)	21.7 (0.854)

*: Always check with the Parts Department for the latest parts information.

SERVICE DATA AND SPECIFICATIONS (SDS)

Output Shaft

ECS006G5

SEAL RING CLEARANCE

Output shaft seal ring clearance mm (in)	Standard	0.10 - 0.25 (0.0039 - 0.0098)
	Allowable limit	0.25 (0.0098)

SEAL RING

Outer diameter mm (in)	Inner diameter mm (in)	Width mm (in)	Part number*
33.71 (1.327)	30.25 (1.191)	1.95 (0.077)	31525-80809

*: Always check with the Parts Department for the latest parts information.

END PLAY

Output shaft end play mm (in)	0 - 0.15 (0 - 0.0059)
-------------------------------	-----------------------

OUTPUT SHAFT ADJUSTING SHIMS

Thickness mm (in)	Part number*
0.80 (0.0315)	31438-80X60
0.84 (0.0331)	31438-80X61
0.88 (0.0346)	31438-80X62
0.92 (0.0362)	31438-80X63
0.96 (0.0378)	31438-80X64
1.00 (0.0394)	31438-80X65
1.04 (0.0409)	31438-80X66
1.08 (0.0425)	31438-80X67
1.12 (0.0441)	31438-80X68
1.16 (0.0457)	31438-80X69
1.20 (0.0472)	31438-80X70

*: Always check with the Parts Department for the latest parts information.

Bearing Retainer

ECS006G6

SEAL RING CLEARANCE

Bearing retainer seal ring clearance mm (in)	Standard	0.10 - 0.30 (0.0039 - 0.0118)
	Allowable limit	0.30 (0.0118)

Total End Play

ECS006G7

Total end play mm (in)	0.25 - 0.55 (0.0098 - 0.0217)
------------------------	-------------------------------

BEARING RACE FOR ADJUSTING TOTAL END PLAY

Thickness mm (in)	Part number*
0.8 (0.031)	31435-80X00
1.0 (0.039)	31435-80X01
1.2 (0.047)	31435-80X02
1.4 (0.055)	31435-80X03
1.6 (0.063)	31435-80X04
1.8 (0.071)	31435-80X05
2.0 (0.079)	31435-80X06
0.9 (0.035)	31435-80X09
1.1 (0.043)	31435-80X10
1.3 (0.051)	31435-80X11
1.5 (0.059)	31435-80X12
1.7 (0.067)	31435-80X13
1.9 (0.075)	31435-80X14

*: Always check with the Parts Department for the latest parts information.

Reverse Clutch End Play

ECS006G8

Reverse clutch end play mm (in)	0.55 - 0.90 (0.0217 - 0.0354)
---------------------------------	-------------------------------

SERVICE DATA AND SPECIFICATIONS (SDS)

THRUST WASHERS FOR ADJUSTING REVERSE CLUTCH DRUM END PLAY

Thickness mm (in)	Part number*
0.80 (0.0315)	31508-80X13
0.95 (0.0374)	31508-80X14
1.10 (0.0433)	31508-80X15
1.25 (0.0492)	31508-80X16
1.40 (0.0551)	31508-80X17
1.55 (0.0610)	31508-80X18
1.70 (0.0669)	31508-80X19
1.85 (0.0728)	31508-80X20

*: Always check with the Parts Department for the latest parts information.

Removal and Installation

ECS006G9

Unit: mm (in)

Distance between end of converter housing and torque converter	14 (0.55)
--	-----------

Shift Solenoid Valves

ECS006GA

Gear position	1	2	3	4
Shift solenoid valve A	ON (Closed)	OFF (Open)	OFF (Open)	ON (Closed)
Shift solenoid valve B	ON (Closed)	ON (Closed)	OFF (Open)	OFF (Open)

Solenoid Valves

ECS006GB

Solenoid valves	Resistance (Approx.) Ω	Terminal No.
Shift solenoid valve A	20 - 30	2
Shift solenoid valve B	5 - 20	1
Overrun clutch solenoid valve	20 - 30	3
Line pressure solenoid valve	2.5 - 5	4
Torque converter clutch solenoid valve	5 - 20	5

A/T Fluid Temperature Sensor

ECS006GC

Remarks: Specification data are reference values.

Monitor item	Condition	Specification (Approximately)	
A/T fluid temperature sensor	Cold [20°C (68°F)]	1.5V	2.5 kΩ
	↓	↓	↓
	Hot [80°C (176°F)]	0.5V	0.3 kΩ

Revolution Sensor

ECS006GD

Condition	Judgement standard
When moving at 20 km/h (12 MPH), use the CONSULT-II pulse frequency measuring function.*1 CAUTION: Connect the diagnosis data link cable to the vehicle diagnosis connector. *1: A circuit tester cannot be used to test this item.	450 Hz (Approx.)
When vehicle parks.	0V

Dropping Resistor

ECS006GE

Resistance	10 - 15Ω
------------	----------

SERVICE DATA AND SPECIFICATIONS (SDS)

Turbine Revolution Sensor

ECS006GF

Condition	Judgement standard
When moving at 20 km/h (12 MPH), use the CONSULT-II pulse frequency measuring function.*1 CAUTION: Connect the diagnosis data link cable to the vehicle diagnosis connector. *1: A circuit tester cannot be used to test this item.	240 Hz (Approx.)
When vehicle parks.	Under 1.3V or over 4.5V

A

B

AT

D

E

F

G

H

I

J

K

L

M

SERVICE DATA AND SPECIFICATIONS (SDS)
