

A
B
C

SECTION SC

STARTING & CHARGING SYSTEM

CONTENTS

<p>PRECAUTIONS 2</p> <p> Precautions for Supplemental Restraint System (SRS) "AIR BAG" and "SEAT BELT PRE-TENSIONER" 2</p> <p> Wiring Diagrams and Trouble Diagnosis 2</p> <p>PREPARATION 3</p> <p> Special Service Tool 3</p> <p> Commerical Service Tools 3</p> <p>BATTERY 4</p> <p> How to Handle Battery 4</p> <p> METHODS OF PREVENTING OVER-DISCHARGE 4</p> <p> CHECKING ELECTROLYTE LEVEL 4</p> <p> SPECIFIC GRAVITY CHECK 5</p> <p> CHARGING THE BATTERY 6</p> <p> Trouble Diagnoses with Battery/Starting/Charging System Tester 6</p> <p> DIAGNOSTIC RESULT ITEM CHART 8</p> <p>STARTING SYSTEM 9</p> <p> System Description 9</p> <p> M/T MODEL 9</p> <p> A/T MODEL 9</p> <p> CAN Communication System Description 9</p> <p> FOR TCS MODELS 10</p> <p> FOR A/T MODELS 11</p> <p> FOR M/T MODELS 12</p> <p> Wiring Diagram — START — 14</p> <p> M/T MODEL 14</p> <p> A/T MODEL 15</p> <p> Trouble Diagnoses with Battery/Starting/Charging System Tester 16</p>	<p> DIAGNOSTIC RESULT ITEM CHART 16</p> <p> WORK FLOW 17</p> <p> DIAGNOSTIC PROCEDURE 1 18</p> <p> DIAGNOSTIC PROCEDURE 2 19</p> <p> MINIMUM SPECIFICATION OF CRANKING VOLTAGE REFERENCING COOLANT TEMPERATURE 20</p> <p> Construction 20</p> <p> Removal and Installation 23</p> <p> REMOVAL 23</p> <p> Pinion/Clutch Check 24</p> <p>CHARGING SYSTEM 25</p> <p> System Description 25</p> <p> Wiring Diagram — CHARGE — 26</p> <p> Trouble Diagnoses with Battery/Starting/Charging System Tester 27</p> <p> DIAGNOSTIC RESULT ITEM CHART 28</p> <p> WORK FLOW 29</p> <p> DIAGNOSTIC PROCEDURE 1 30</p> <p> DIAGNOSTIC PROCEDURE 2 31</p> <p> DIAGNOSTIC PROCEDURE 3 32</p> <p> MALFUNCTION INDICATOR 33</p> <p> Construction 33</p> <p> Removal and Installation 33</p> <p> QR25DE 33</p> <p> VQ35DE 34</p> <p>SERVICE DATA AND SPECIFICATIONS (SDS) 35</p> <p> Battery 35</p> <p> Starter 35</p> <p> Generator 35</p>
---	--

A
B
C
D
E
F
G
H
I
J
K
L
M
SC

PRECAUTIONS

PRECAUTIONS

PF0:00001

Precautions for Supplemental Restraint System (SRS) “AIR BAG” and “SEAT BELT PRE-TENSIONER”

EKS007RT

The Supplemental Restraint System such as “AIR BAG” and “SEAT BELT PRE-TENSIONER”, used along with a front seat belt, helps to reduce the risk or severity of injury to the driver and front passenger for certain types of collision. This system includes seat belt switch inputs and dual stage front air bag modules. The SRS system uses the seat belt switches to determine the front air bag deployment, and may only deploy one front air bag, depending on the severity of a collision and whether the front occupants are belted or unbelted. Information necessary to service the system safely is included in the SRS and SB section of this Service Manual.

WARNING:

- To avoid rendering the SRS inoperative, which could increase the risk of personal injury or death in the event of a collision which would result in air bag inflation, all maintenance must be performed by an authorized NISSAN/INFINITI dealer.
- Improper maintenance, including incorrect removal and installation of the SRS, can lead to personal injury caused by unintentional activation of the system. For removal of Spiral Cable and Air Bag Module, see the SRS section.
- Do not use electrical test equipment on any circuit related to the SRS unless instructed to in this Service Manual. SRS wiring harnesses can be identified by yellow and/or orange harnesses or harness connectors.

Wiring Diagrams and Trouble Diagnosis

EKS003BF

When you read wiring diagrams, refer to the following:

- [GI-12, "How to Read Wiring Diagrams"](#) .
- [PG-3, "POWER SUPPLY ROUTING CIRCUIT"](#) for power distribution circuit.

When you perform trouble diagnosis, refer to the following:

- [GI-10, "HOW TO FOLLOW TEST GROUPS IN TROUBLE DIAGNOSES"](#).
- [GI-25, "How to Perform Efficient Diagnosis for an Electrical Incident"](#).

PREPARATION

PREPARATION

PFP:00002

Special Service Tool

EKS003BG

A

B

C

D

E

F

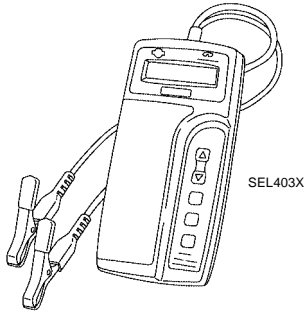
Tool number Tool name	Description
J-44373 Model 620 Battery/Starting/Charging system tester	 <p>SEL403X</p>

Commerical Service Tools

EKS003BH

G

H

I

J

Tool number Tool name	Description
Power tool	Loosening bolts and nuts

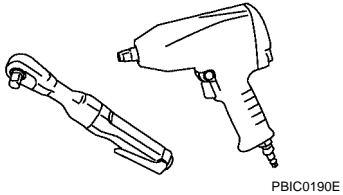

PBIC0190E

SC

L

M

BATTERY

PFP:AYBGL

EKS003BI

BATTERY

How to Handle Battery

CAUTION:

- If it becomes necessary to start the engine with a booster battery and jumper cables, use a 12-volt booster battery.
- After connecting battery cables, ensure that they are tightly clamped to battery terminals for good contact.
- Never add distilled water through the hole used to check specific gravity.

METHODS OF PREVENTING OVER-DISCHARGE

The following precautions must be taken to prevent over-discharging a battery.

- The battery surface (particularly its top) should always be kept clean and dry.
- The terminal connections should be clean and tight.
- At every routine maintenance, check the electrolyte level. This also applies to batteries designated as "low maintenance" and "maintenance-free".

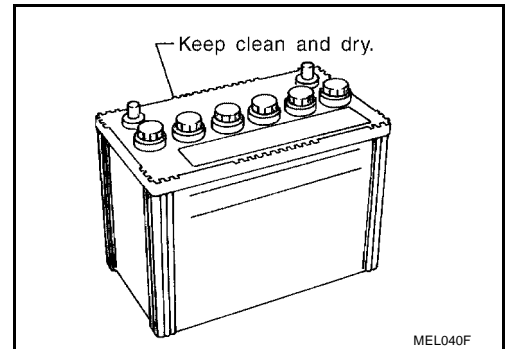

- When the vehicle is not going to be used over a long period of time, disconnect the negative battery terminal.

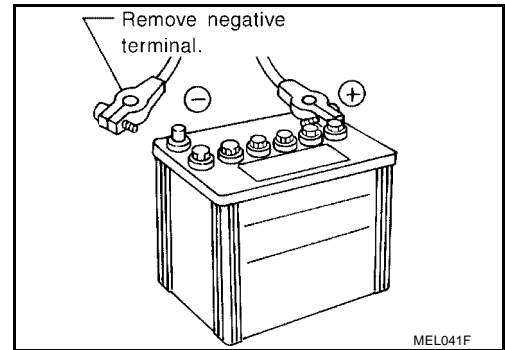

- Check the charge condition of the battery. Periodically check the specific gravity of the electrolyte. Keep a close check on charge condition to prevent over-discharge.

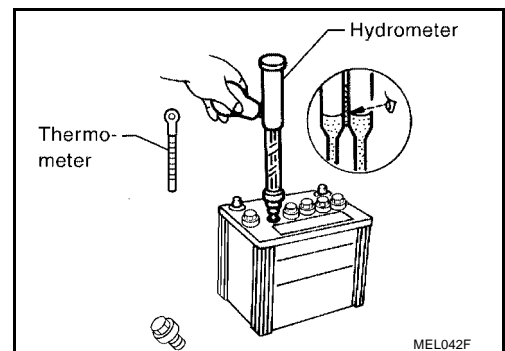

CHECKING ELECTROLYTE LEVEL

WARNING:

Do not allow battery fluid to come in contact with skin, eyes, fabrics, or painted surfaces. After touching a battery, do not touch or rub your eyes until you have thoroughly washed your hands. If acid contacts eyes, skin or clothing, immediately flush with water for 15 minutes and seek medical attention.

BATTERY

- Remove the cell plug using a suitable tool.
- Add distilled water up to the MAX level.

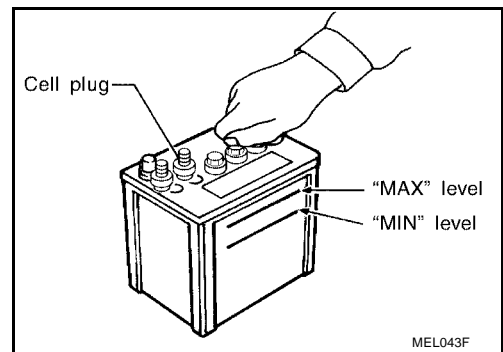

Sulphation

A battery will be completely discharged if it is left unattended for a long time and the specific gravity will become less than 1.100. This may result in sulphation on the cell plates.

To determine if a battery has been “sulphated”, note its voltage and current when charging it. As shown in the figure, less current and higher voltage are observed in the initial stage of charging sulphated batteries.

A sulphated battery may sometimes be brought back into service by means of a long, slow charge, 12 hours or more, followed by a battery capacity test.

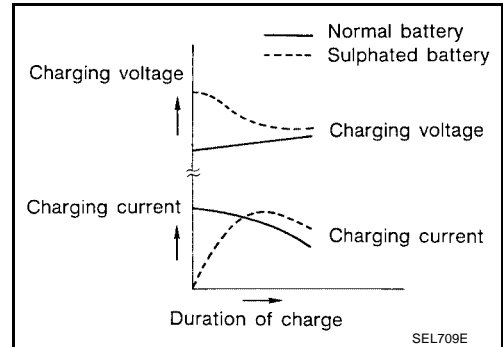

SPECIFIC GRAVITY CHECK

1. Read hydrometer and thermometer indications at eye level.
2. Use the following chart to correct your hydrometer reading according to electrolyte temperature.

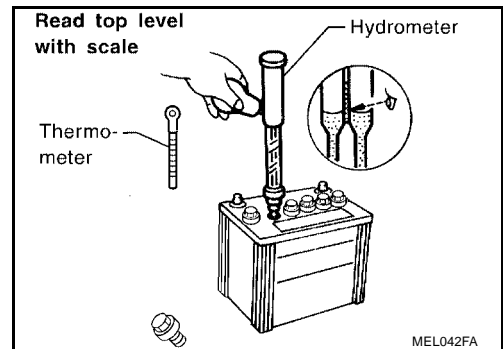

Hydrometer Temperature Correction

Battery electrolyte temperature °C (°F)	Add to specific gravity reading
71 (160)	0.032
66 (150)	0.028
60 (140)	0.024
54 (130)	0.020
49 (120)	0.016
43 (110)	0.012
38 (100)	0.008
32 (90)	0.004
27 (80)	0
21 (70)	-0.004
16 (60)	-0.008
10 (50)	-0.012
4 (40)	-0.016
-1 (30)	-0.020
-7 (20)	-0.024

A
B
C
D
E
F
G
H
I
J
SC
L
M

BATTERY

Battery electrolyte temperature °C (°F)	Add to specific gravity reading
-12 (10)	-0.028
-18 (0)	-0.032

Corrected specific gravity	Approximate charge condition
1.260 - 1.280	Fully charged
1.230 - 1.250	3/4 charged
1.200 - 1.220	1/2 charged
1.170 - 1.190	1/4 charged
1.140 - 1.160	Almost discharged
1.110 - 1.130	Completely discharged

CHARGING THE BATTERY

CAUTION:

- Do not “quick charge” a fully discharged battery.
- Keep the battery away from open flame while it is being charged.
- When connecting the charger, connect the leads first, then turn on the charger. Do not turn on the charger first, as this may cause a spark.
- If battery electrolyte temperature rises above 60°C (140°F), stop charging. Always charge battery at a temperature below 60°C (140°F).

Charging Rates

Amps	Time
50	1 hour
25	2 hours
10	5 hours
5	10 hours

Do not charge at more than 50 ampere rate.

NOTE:

The ammeter reading on your battery charger will automatically decrease as the battery charges. This indicates that the voltage of the battery is increasing normally as the state of charge improves. The charging amps indicated above refer to initial charge rate.

- If, after charging, the specific gravity of any two cells varies more than .050, the battery should be replaced.

Trouble Diagnoses with Battery/Starting/Charging System Tester

EKS003BJ

CAUTION:

When working with batteries, always wear appropriate eye protection.

NOTE:

- To ensure a complete and thorough diagnosis, the battery, starter and generator test segments must be done as a set from start to finish.
- If battery surface charge is detected while testing, the tester will prompt you to turn on the headlights to remove the surface charge.
- If necessary, the tester will prompt you to determine if the battery temperature is above or below 0°C (32°F). Choose the appropriate selection by pressing the up or down arrow button, then press “ENTER” to make the selection.

BATTERY

1. Turn off all loads on the vehicle electrical system. Clean or repair as necessary.
2. Visually inspect the battery, battery terminals and cable ends with ignition switch in "OFF" position.

NOTE:

The contact surface between the battery terminals, cable ends and tester leads must be clean for a valid test. A poor connection will prevent testing and a "CHECK CONNECTION" message will appear during the test procedures. If this occurs, clean the battery post and terminals, reconnect them and restart the test.

3. Connect the red tester lead clamp to the positive battery terminal, and the black to the negative terminal.
4. The tester will turn on automatically. Using the arrow keys, select "IN-VEHICLE" on the tester and then press the "ENTER" key.

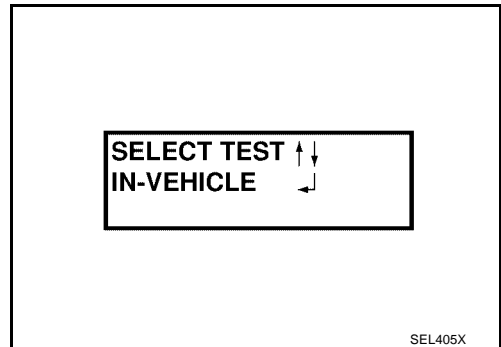
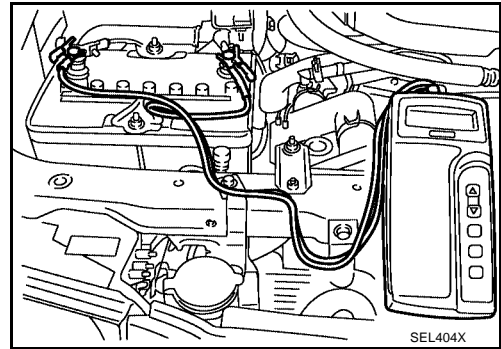

5. Locate the battery type and rating stamped or written on the top case of the battery to be tested.

NOTE:

The battery type and rating will have either of the following.

CCA: Cold Cranking Amps (490 CCA, 550 CCA, etc.)

JIS: Japanese Industrial Standard.

Battery is stamped with a number such as:

80D26L: 80 (rank of output), D (physical size-depth), 26 (width in cm). The last character L (post configuration) is not input into the tester.

The tester requires the rating for the battery be entered exactly as it is written or stamped on the battery. Do not attempt a CCA conversion for JIS stamped batteries. JIS must be input directly.

6. Using the arrow and "ENTER" keys alternately, select the battery type and rating.

NOTE:

The tester lists five choices; CCA, JIS, IEC, DIN, and EN. Only use CCA or JIS.

7. Press "ENTER" to begin the test. Diagnosis results are displayed on the tester. Refer to [SC-8. "DIAGNOSTIC RESULT ITEM CHART"](#).

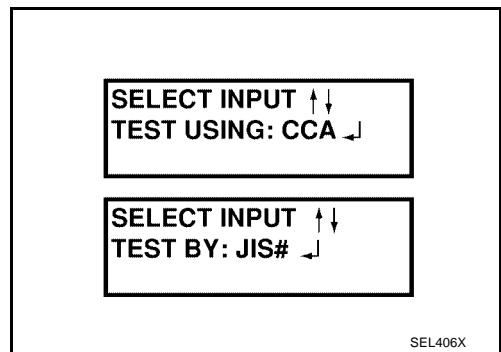

A
B
C
D
E
F
G
H
I
J
SC
L
M

BATTERY

8. Press "ENTER", then test output code is displayed. Record the test output code on the repair order.
9. Toggle back to the "DIAGNOSTIC SCREEN" for test results.

NOTE:

- If necessary, the tester will ask the user to determine if the battery has just been charged. Choose the appropriate selection by pressing the up or down arrow button and then press the "ENTER" button to make the selection.
- When testing a battery installed in a vehicle that has recently been driven, select "BEFORE CHARGE".
- If the battery has just been slow charged due to a "CHARGE & RETEST" decision by the tester, and the tester asks the user "BEFORE CHARGE/AFTER CHARGE", select "AFTER CHARGE".

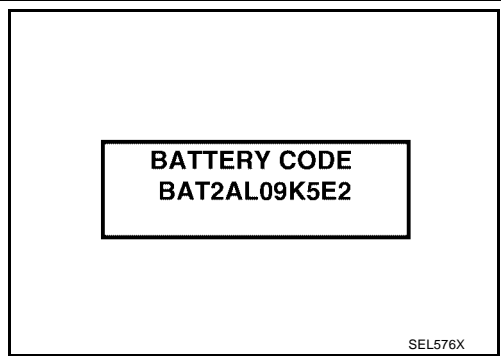

DIAGNOSTIC RESULT ITEM CHART

Diagnostic item	Service procedure
GOOD BATTERY	Battery is OK. Refer to SC-6. "Trouble Diagnoses with Battery/Starting/Charging System Tester" .
REPLACE BATTERY	Replace battery. Before replacing battery, clean the battery cable clamps and battery posts. Perform battery test again with Battery/Starting/Charging system tester. If second test result is "Replace Battery", then do so. Perform battery test again to confirm repair.
BAD CELL-REPLACE	Replace the battery. Perform battery test again with Battery/Starting/Charging system tester to confirm repair.
GOOD-RECHARGE	Perform the slow battery charging procedure. (Initial rate of charge is 10A for 12 hours.) Perform battery test again with Battery/Starting/Charging system tester.
CHARGE & RETEST	Perform the slow battery charging. (Initial rate of charge is 10A for 12 hours.) Perform battery test again with Battery/Starting/Charging system tester to confirm repair. NOTE: If the tester asks the user "BEFORE CHARGE/AFTER CHARGE", select "AFTER CHARGE".

STARTING SYSTEM

STARTING SYSTEM

PF2:23300

System Description M/T MODEL

EKS003BK

Power is supplied at all times:

- through 40A fusible link (letter **m** , located in the fuse and fusible link box)
- to ignition switch terminal B.

With the ignition switch in the START position, power is supplied:

- from ignition switch terminal ST
- to intelligent power distribution module engine room (IPDM E/R) terminal 11.

With the ignition switch in the ON or START position, power is supplied:

- through 10A fuse [No. 12, located in the fuse block (J/B)]
- to intelligent power distribution module engine room (IPDM E/R) terminal 43.

When the clutch pedal is depressed, ground is supplied to intelligent power distribution module engine room (IPDM E/R) terminal 46 through the clutch interlock switch and body grounds E15 and E24.

Provided that the intelligent power distribution module (IPDM E/R) receives a starter relay on signal from the BCM over the CAN lines, the IPDM E/R is energized and power is supplied:

- from terminal 4 of the starter relay
- to terminal S of the starter motor windings.

The starter motor plunger closes and provides a closed circuit between the battery and the starter motor. The starter motor is grounded to the cylinder block. With power and ground supplied, the starter motor operates. In the event that the CAN communication line fails, the IPDM E/R will continue to receive a starter relay on signal from the BCM as long as the ignition switch remains in the START or ON positions.

A/T MODEL

Power is supplied at all times:

- through 40A fusible link (letter **m** , located in the fuse and fusible link box)
- to ignition switch terminal B.

With the ignition switch in the START position, power is supplied:

- from ignition switch terminal ST
- to intelligent power distribution module engine room (IPDM E/R) terminal 11.

With the ignition switch in the ON or START position, power is supplied:

- through 10A fuse [No. 12, located in the fuse block (J/B)]
- to intelligent power distribution module engine room (IPDM E/R) terminal 43.

Ground is supplied, with the selector lever in the P or N position:

- to intelligent power distribution module engine room (IPDM E/R) terminal 46
- through park/neutral position switch terminal 1 and 2
- through engine grounds F17 and F15.

The starter motor plunger closes and provides a closed circuit between the battery and the starter motor. The starter motor is grounded to the cylinder block. With power and ground supplied, the starter motor operates. In the event that the CAN communication line fails, the IPDM E/R will continue to receive a starter relay on signal from the BCM as long as the ignition switch remains in the START or ON positions.

CAN Communication System Description

EKS003BL

CAN (Controller Area Network) is a serial communication line for real time application. It is an on-vehicle multiplex communication line with high data communication speed and excellent error detection ability. Many electronic control units are equipped onto a vehicle, and each control unit shares information and links with other control units during operation (not independent). In CAN communication, control units are connected with 2 communication lines (CAN H line, CAN L line) allowing a high rate of information transmission with less wiring. Each control unit transmits/receives data but selectively reads required data only.

STARTING SYSTEM

FOR TCS MODELS

System diagram

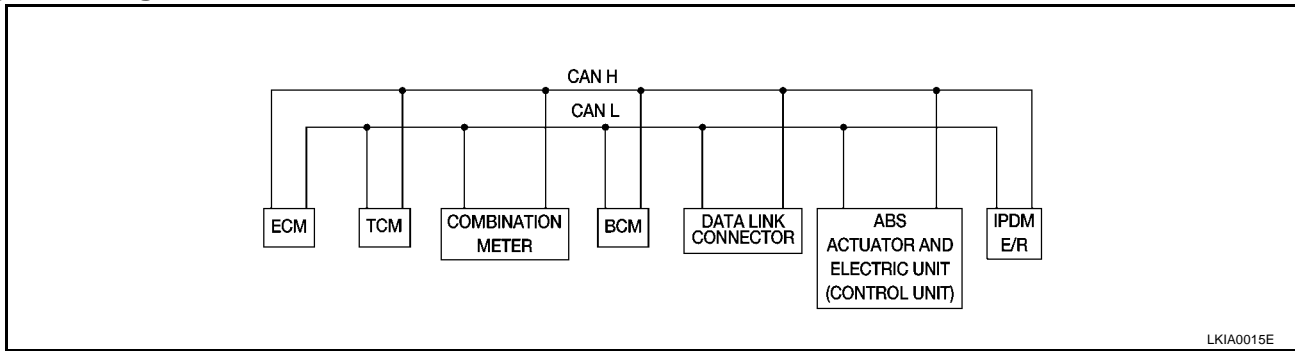

LKIA0015E

Input/output signal chart

T: Transmit R: Receive

Signals	ECM	TCM	COMBINATION METER	BCM	ABS/TCS control unit	IPDM E/R
Engine speed signal	T		R		R	
Engine coolant temperature signal	T		R			
Accelerator pedal position signal	T					
Fuel consumption monitor signal	T		R			
A/T warning lamp signal		T	R			
A/T position indicator signal	R	T	R	R ^(R range only)	R	
ABS operation signal	R				T	
TCS operation signal	R	R			T	
Air conditioner switch signal	R			T		
Air conditioner compressor signal	R					T
A/C compressor request signal	T					R
Cooling fan motor operation signal	R					T
Cooling fan speed request signal	T					R
Position lights request			R	T		R
Position lights status				R		T
Low beam request				T		R
Low beam status	R			R		T
High beam request			R	T		R
High beam status	R			R		T
Front fog lights request				T		R
Front fog light status				R		T
OD cancel switch signal		R	T			R
Brake switch signal		R	T			
Vehicle speed signal	R		T			
	R		T	R		
Oil pressure switch			R			T
Sleep request1			R	T		
Sleep request2				T		R
N range switch signal		R	T			
P range switch signal		R	T			
Seat belt buckle switch signal			T	R		

STARTING SYSTEM

Signals	ECM	TCM	COMBINATION METER	BCM	ABS/TCS control unit	IPDM E/R
Door switch signal			R	T		R
Tail lamp request			R	T		R
Turn indicator signal			R	T		
Buzzer output signal			R	T		
Trunk switch signal			R	T		
ASCD main switch signal	T		R			
ASCD cruise signal	T		R			
Wiper operation				R		T
Wiper stop position signal				R		T
Rear window defogger switch signal				T		R
Rear window defogger control signal	R			R		T

FOR A/T MODELS

System diagram

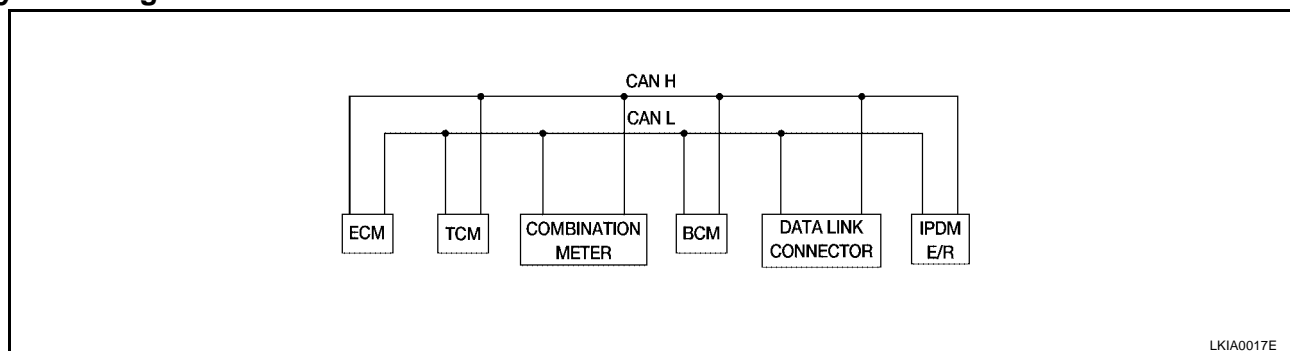

LKIA0017E

Input/output signal chart

T: Transmit R: Receive

Signals	ECM	TCM	COMBINATION METER	BCM	IPDM E/R
Engine speed signal	T		R		
Engine coolant temperature signal	T		R		
Accelerator pedal position signal	T				R
Fuel consumption monitor signal	T		R		
A/T warning lamp signal		T	R		
A/T position indicator signal	R	T	R	R ^(R range only)	
Air conditioner switch signal	R			T	
Air conditioner compressor signal	R				T
A/C compressor request signal	T				R
Blower fan switch signal	R ^(QR25DE)			T	
Cooling fan motor operation signal	R			T	
Cooling fan speed request signal	T				R
Position lights request			R	T	R
Position lights status				R	T
Low beam request				T	R
Low beam status	R			R	T
High beam request			R	T	R

STARTING SYSTEM

Signals	ECM	TCM	COMBINATION METER	BCM	IPDM E/R
High beam status	R			R	T
Front fog lights request				T	R
Front fog light status				R	T
OD cancel switch signal		R	T		R
Brake switch signal		R	T		
Vehicle speed signal	R		T		
	R		T	R	
Oil pressure switch			R		T
Sleep request1			R	T	
Sleep request2				T	R
N range switch signal		R	T		
P range switch signal		R	T		
Seat belt buckle switch signal			T	R	
Door switch signal			R	T	R
Tail lamp request			R	T	R
Turn indicator signal			R	T	
Buzzer output signal			R	T	
Trunk switch signal			R	T	
ASCD main switch signal	T		R		
ASCD cruise signal	T		R		
Wiper operation				R	T
Wiper stop position signal				R	T
Rear window defogger switch signal				T	R
Rear window defogger control signal	R			R	T

FOR M/T MODELS

System diagram

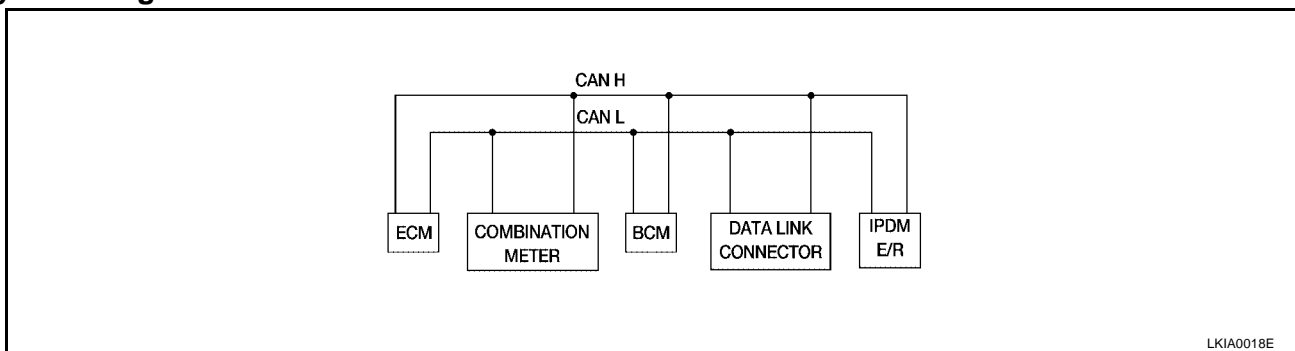

LKIA0018E

Input/output signal chart

T: Transmit R: Receive

Signals	ECM	COMBINATION METER	BCM	IPDM E/R
Engine speed signal	T			
Engine coolant temperature signal	T			
Fuel consumption monitor signal	T			
Air conditioner switch signal	R		T	
Air conditioner compressor signal	R			T
A/C compressor request signal	T			R

STARTING SYSTEM

Signals	ECM	COMBINATION METER	BCM	IPDM E/R	
Blower fan switch signal	R ^(QR25DE)		T		A
Cooling fan motor operation signal	R			T	B
Cooling fan speed request signal	T			R	
Position lights request		R	T	R	C
Position lights status			R	T	
Low beam request			T	R	
Low beam status	R		R	T	D
High beam request		R	T	R	E
High beam status	R		R	T	
Front fog lights request			T	R	F
Front fog light status			R	T	
Vehicle speed signal	R	T			G
Oil pressure switch		R		T	
Sleep request1		R	T		H
Sleep request2			T	R	
Seat belt buckle switch signal		T	R		I
Door switch signal		R	T	R	
Tail lamp request		R	T	R	J
Turn indicator signal		R	T		
Buzzer output signal		R	T		
Trunk switch signal		R	T		
ASCD main switch signal	T	R			
ASCD cruise signal	T	R			
Wiper operation			R	T	
Wiper stop position signal			R	T	
Rear window defogger switch signal			T	R	
Rear window defogger control signal	R		R	T	

A
B
C
D
E
F
G
H
I
J
L
M

SC

STARTING SYSTEM

EKS003BM

Wiring Diagram — START — M/T MODEL

SC-START-01

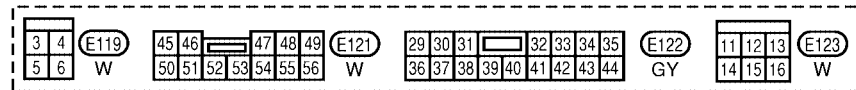
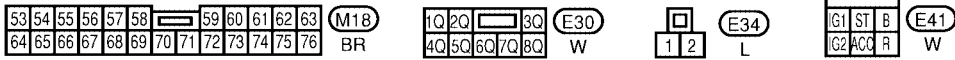
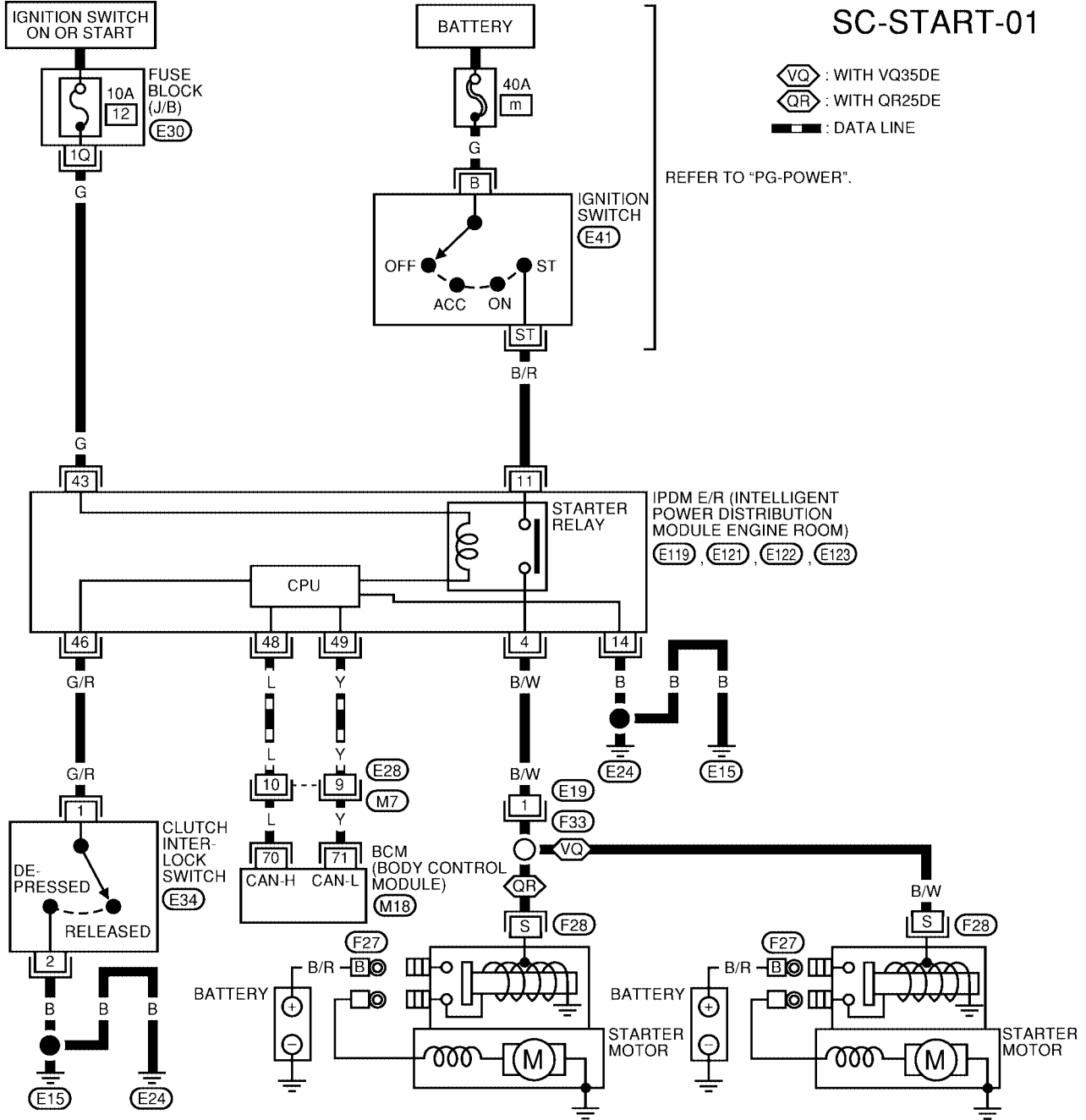

WKWA1147E

STARTING SYSTEM

A/T MODEL

SC-START-02

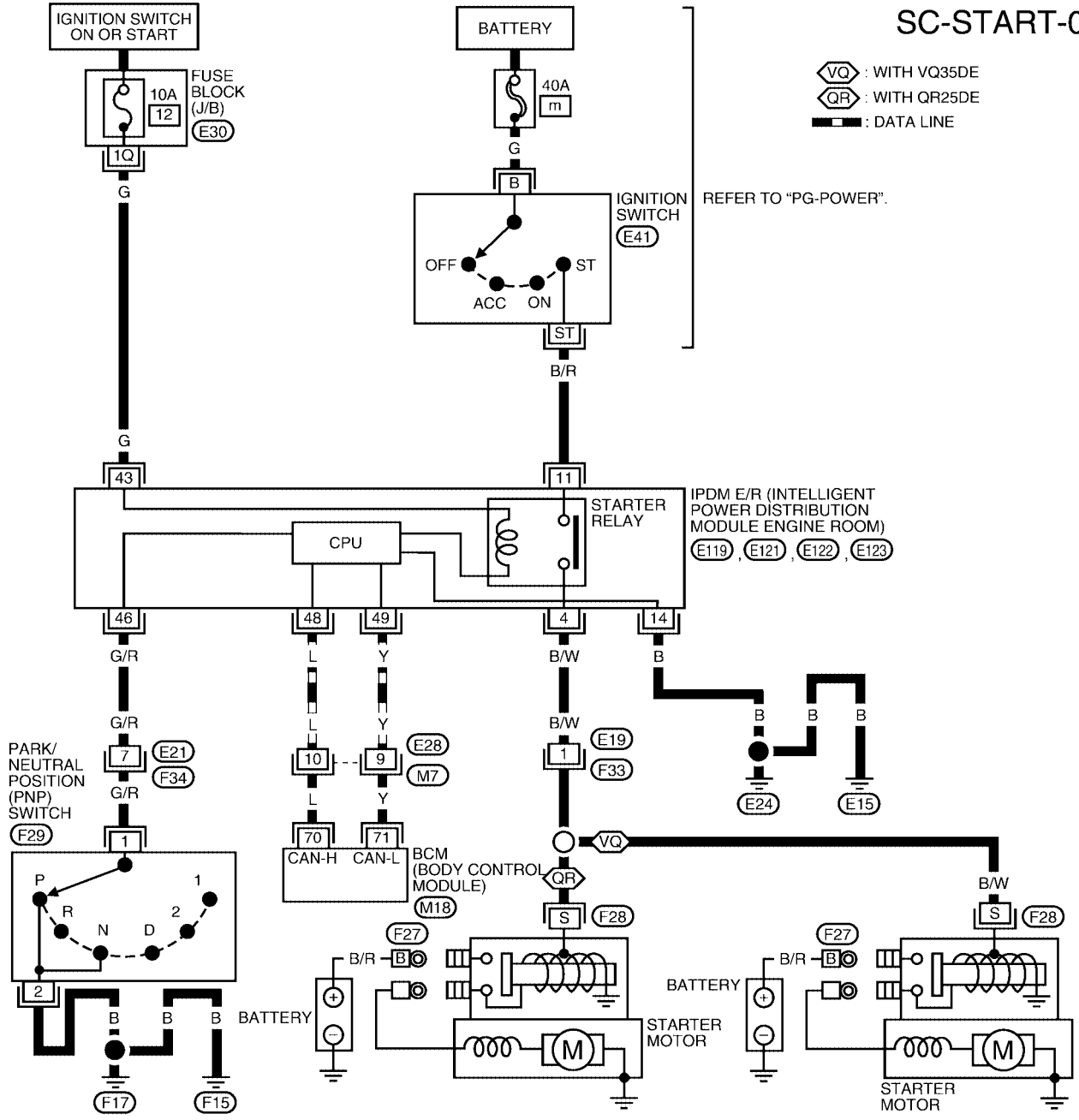

A
B
C
D
E
F
G
H
I
J
SC
L
M

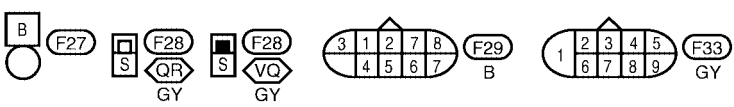
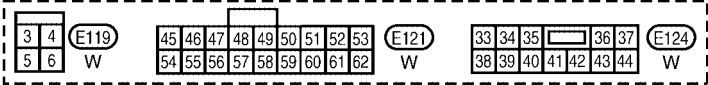
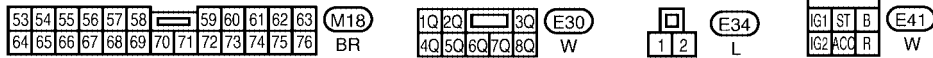

WKWA1148E

STARTING SYSTEM

EKS003BN

Trouble Diagnoses with Battery/Starting/Charging System Tester

NOTE:

To ensure a complete and thorough diagnosis, the battery, starter and generator test segments must be done as a set from start to finish.

1. Turn off all loads on the vehicle electrical system.
2. Perform battery test with Battery/Starting/Charging system tester. Refer to [SC-16, "Trouble Diagnoses with Battery/Starting/Charging System Tester"](#).
3. Press "ENTER" to begin the starting system test.



4. Start the engine.

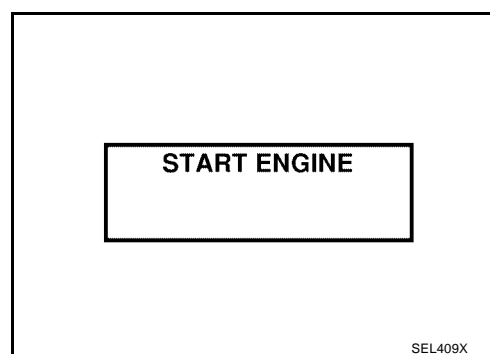

5. Diagnosis result is displayed on the tester. Refer to [SC-16, "DIAGNOSTIC RESULT ITEM CHART"](#).

NOTE:

- If the starter performs normally but the engine does not start, perform engine diagnosis.
- For intermittent "NO CRANK" or "NO STARTER OPERATION" incidents, refer to [SC-19, "DIAGNOSTIC PROCEDURE 2"](#).

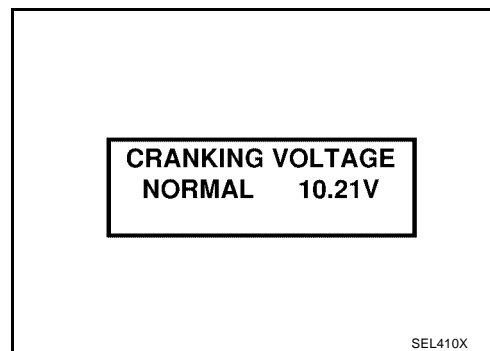

DIAGNOSTIC RESULT ITEM CHART

Diagnostic item	Service procedure
CRANKING VOLTAGE NORMAL	Go to "WORK FLOW", SC-17, "WORK FLOW" .
CRANKING VOLTAGE LOW	Go to "WORK FLOW", SC-17, "WORK FLOW" .
CHARGE BATTERY	Perform the slow battery charging procedure. (Initial rate of charge is 10A for 12 hours.) Perform battery test again with Battery/Starting/Charging system tester. Refer to SC-16, "Trouble Diagnoses with Battery/Starting/Charging System Tester" .
REPLACE BATTERY	Before replacing battery, clean the battery cable clamps and battery posts. Perform battery test again with Battery/Starting/Charging system tester. Refer to SC-16, "Trouble Diagnoses with Battery/Starting/Charging System Tester" . If second test result is "REPLACE BATTERY", then do so. Perform battery test again to confirm repair.

STARTING SYSTEM

WORK FLOW

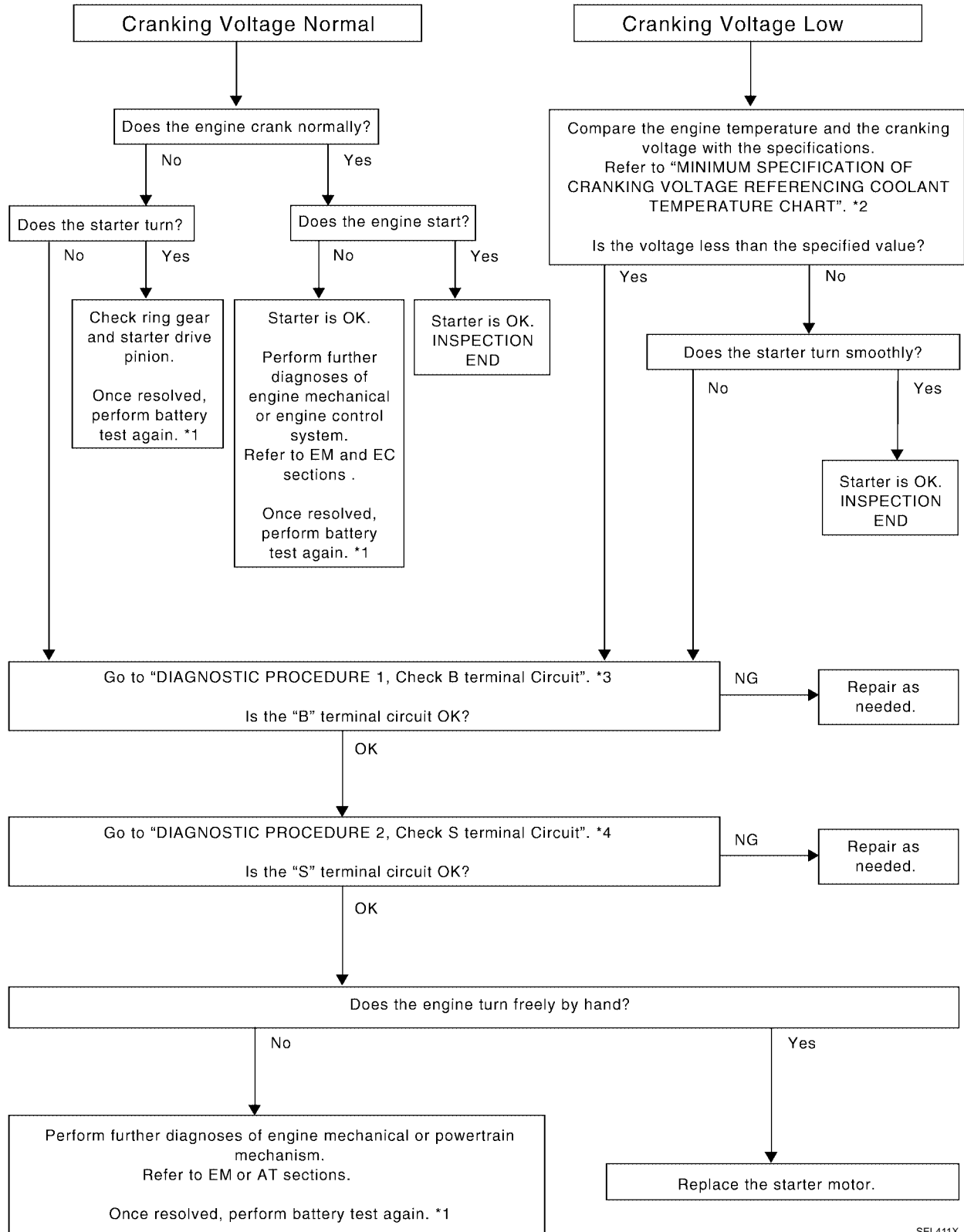

*1 [SC-16](#)

*2 [SC-18](#)

*3 [SC-19](#)

*4 [SC-19](#)

SEL411X

STARTING SYSTEM

DIAGNOSTIC PROCEDURE 1

Check "B" Terminal Circuit

1. CHECK POWER SUPPLY FOR STARTER MOTOR "B" TERMINAL

1. Remove the fuel pump fuse.
2. Crank or start the engine (where possible) until the fuel pressure is released.
3. Turn the ignition switch OFF.
4. Check that the starter motor connector F27 terminal B (B/R) connection is clean and tight.
5. Check voltage between starter motor connector F27 terminal B (B/R) and ground using a digital circuit tester.

Battery voltage should exist

OK or NG

OK >> GO TO 2.

NG >> Check harness between the battery and the starter motor for open circuit.

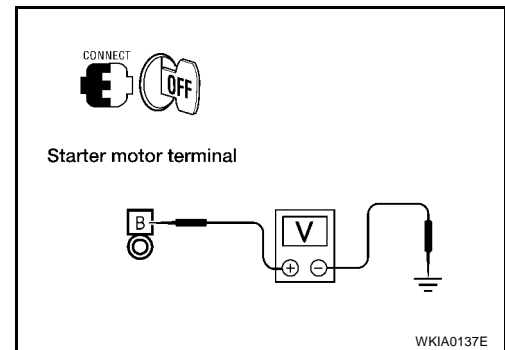

2. CHECK BATTERY CABLE CONNECTION QUALITY (VOLTAGE DROP TEST)

1. Check voltage between starter motor connector F27 terminal B (B/R) and battery positive terminal using a digital circuit tester.

Ignition switch in START : Less than 0.5V

OK or NG

OK >> GO TO 3.

NG >> Check harness between the battery and the starter motor for poor continuity.

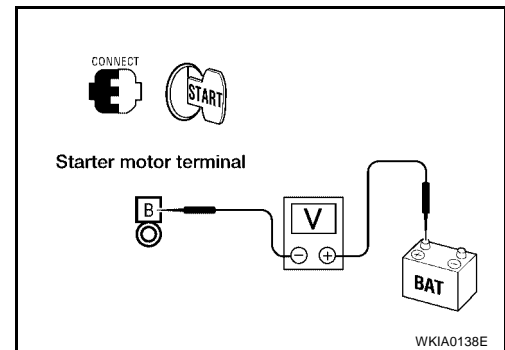

3. CHECK STARTER MOTOR GROUND CIRCUIT (VOLTAGE DROP TEST)

1. Check voltage between starter motor case and battery negative terminal using a digital circuit tester.

Ignition switch in START : Less than 0.2V

OK or NG

OK >> Starter motor "B" terminal circuit is OK. Further inspection is necessary. Refer to [SC-17, "WORK FLOW"](#).

NG >> Check harness between the starter motor case and ground for poor continuity.

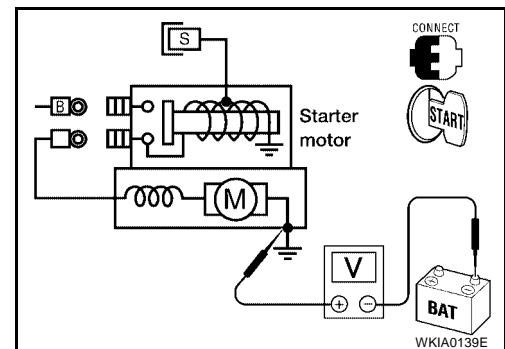

STARTING SYSTEM

DIAGNOSTIC PROCEDURE 2

Check "S" Terminal Circuit

1. CHECK POWER SUPPLY FOR STARTER MOTOR "S" TERMINAL

1. Remove the fuel pump fuse.
2. Crank or start the engine (where possible) until the fuel pressure is released.
3. Turn the ignition switch OFF.
4. Disconnect starter motor connector F28.
5. Check voltage between starter motor connector F28 terminal S (B/W) and ground using a digital circuit tester.

Ignition switch in START : Battery voltage

OK or NG

OK >> GO TO 2.

NG >> Check the following.

- 40A fusible link (letter **m** , located in fuse and fusible link box)
- Starter relay [within the intelligent power distribution module engine room (IPDM E/R)]
- Harness for open or short

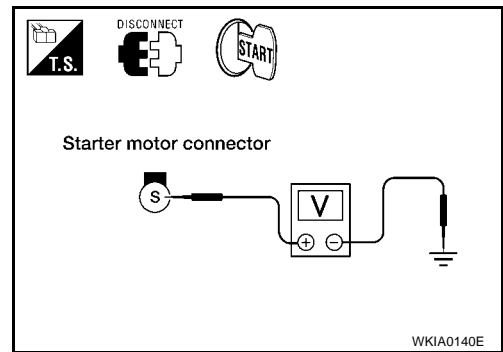

2. CHECK "S" TERMINAL CONNECTION QUALITY (VOLTAGE DROP TEST)

1. Connect starter motor connector F28.
2. Check voltage between starter motor connector F28 terminal S (B/W) and battery positive terminal using a digital tester.

Ignition switch in START : Less than 1V

OK or NG

OK >> Starter motor "S" terminal circuit is OK. Further inspection is necessary. Refer to [SC-17. "WORK FLOW"](#).

NG >> Check harness between the battery and the starter motor "S" terminal for poor continuity.

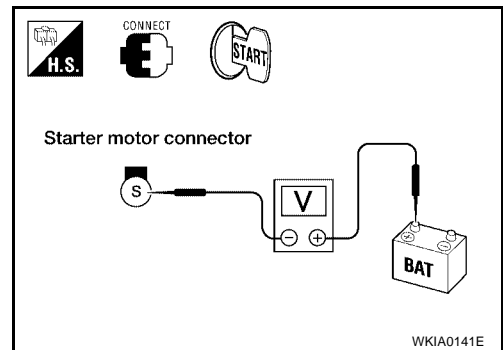

STARTING SYSTEM

MINIMUM SPECIFICATION OF CRANKING VOLTAGE REFERENCING COOLANT TEMPERATURE

Engine coolant temperature	Voltage V	
	QR25DE	VQ35DE
-30°C to -20°C (-22°F to -4°F)	8.7	8.4
-19°C to -10°C (-2°F to 14°F)	9.2	8.9
-9°C to 0°C (16°F to 32°F)	9.6	9.3
More than 1°C (More than 34°F)	10.0	9.7

Construction

EKS003BO

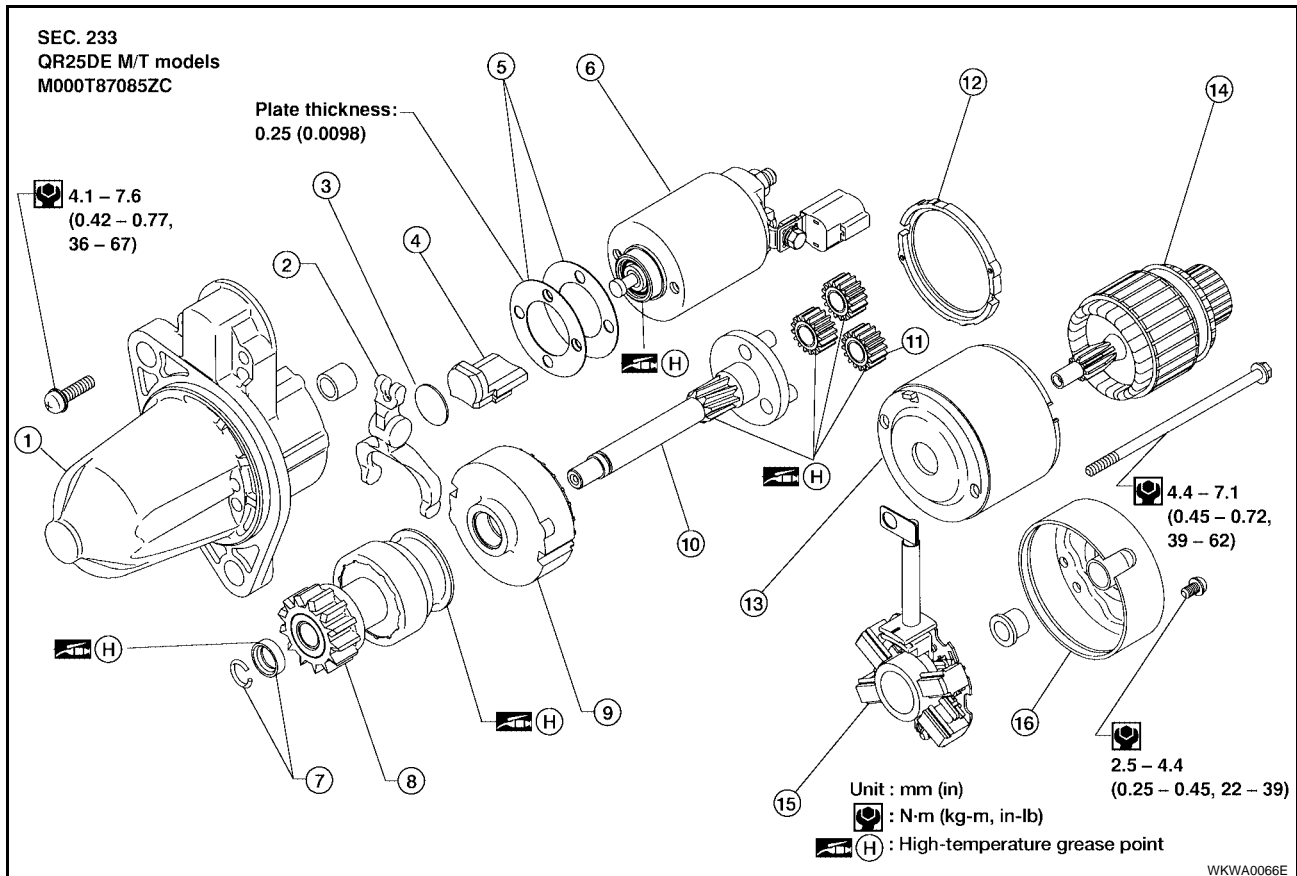

- | | | |
|-----------------------|--------------------|-----------------------------|
| 1. Gear case | 2. Shift lever | 3. Plate |
| 4. Packing | 5. Adjusting plate | 6. Magnetic switch assembly |
| 7. Pinion stopper set | 8. Pinion assembly | 9. Internal gear |
| 10. Pinion shaft | 11. Planetary gear | 12. Packing |
| 13. Yoke | 14. Armature | 15. Brush holder assembly |
| 16. Rear cover | | |

STARTING SYSTEM

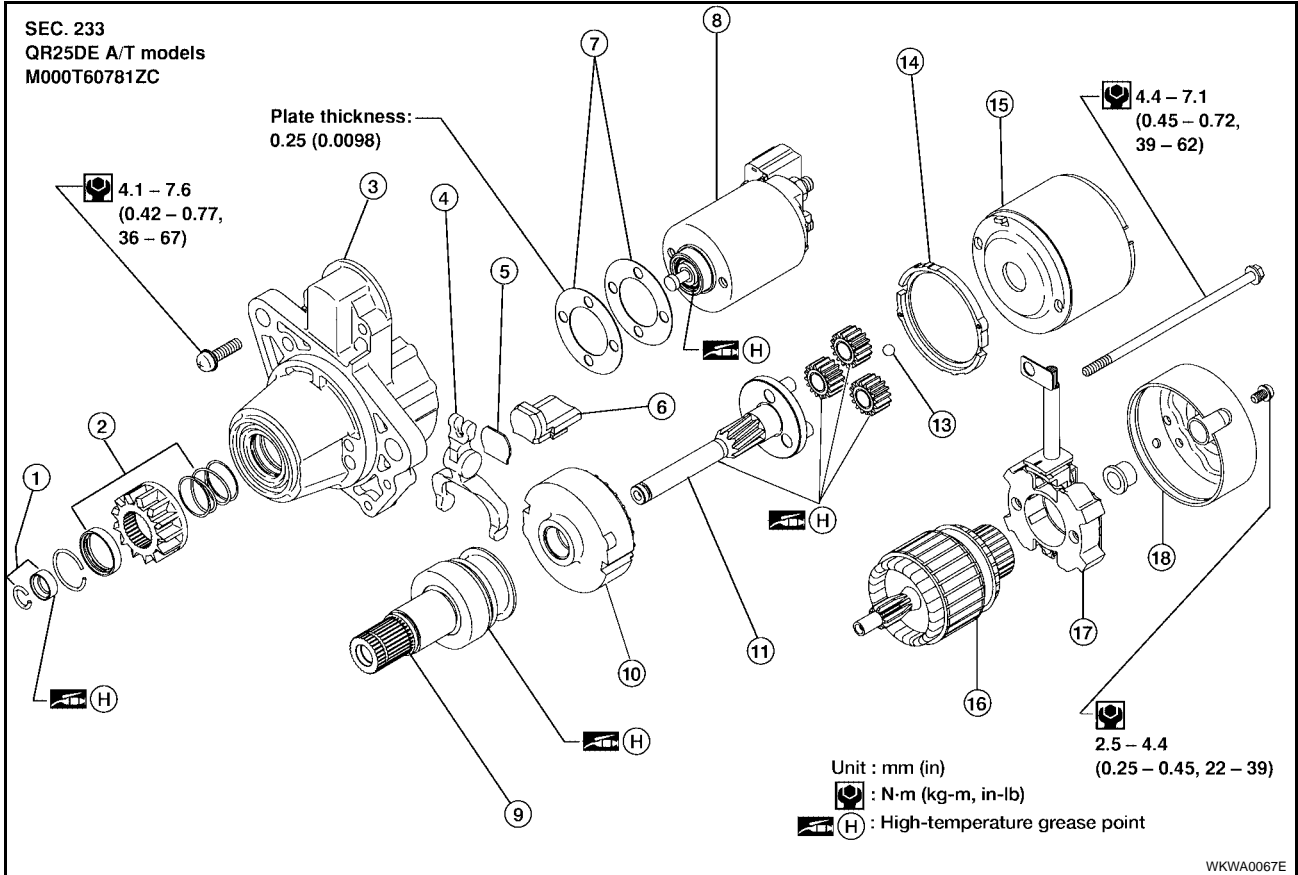

1. Pinion stopper set

2. Pinion set

3. Front bracket

4. Shift lever

5. Plate

6. Magnetic switch assembly

7. Adjusting plate

8. Internal gear

9. Gear shaft

10. Planetary gears

11. Ball

12. Center bracket

13. Yoke assembly

14. Armature

15. Brush assembly

16. Rear bracket

17.

18.

2. Pinion set

5. Plate

8. Magnetic switch assembly

11. Gear shaft

14. Center bracket

17. Brush assembly

10. Internal gear

13. Yoke assembly

16. Armature

19.

20.

21.

22.

23.

24.

25.

26.

3. Front bracket

6. Packing

9. Clutch gear

12. Planetary gears

15. Yoke assembly

18. Rear bracket

10. Internal gear

13. Yoke assembly

16. Armature

19.

20.

21.

22.

23.

24.

25.

26.

A
B
C
D
E
F
G
H
I
J
L
M

SC

STARTING SYSTEM

SEC. 233
VQ35DE M/T models
M000T87281ZC

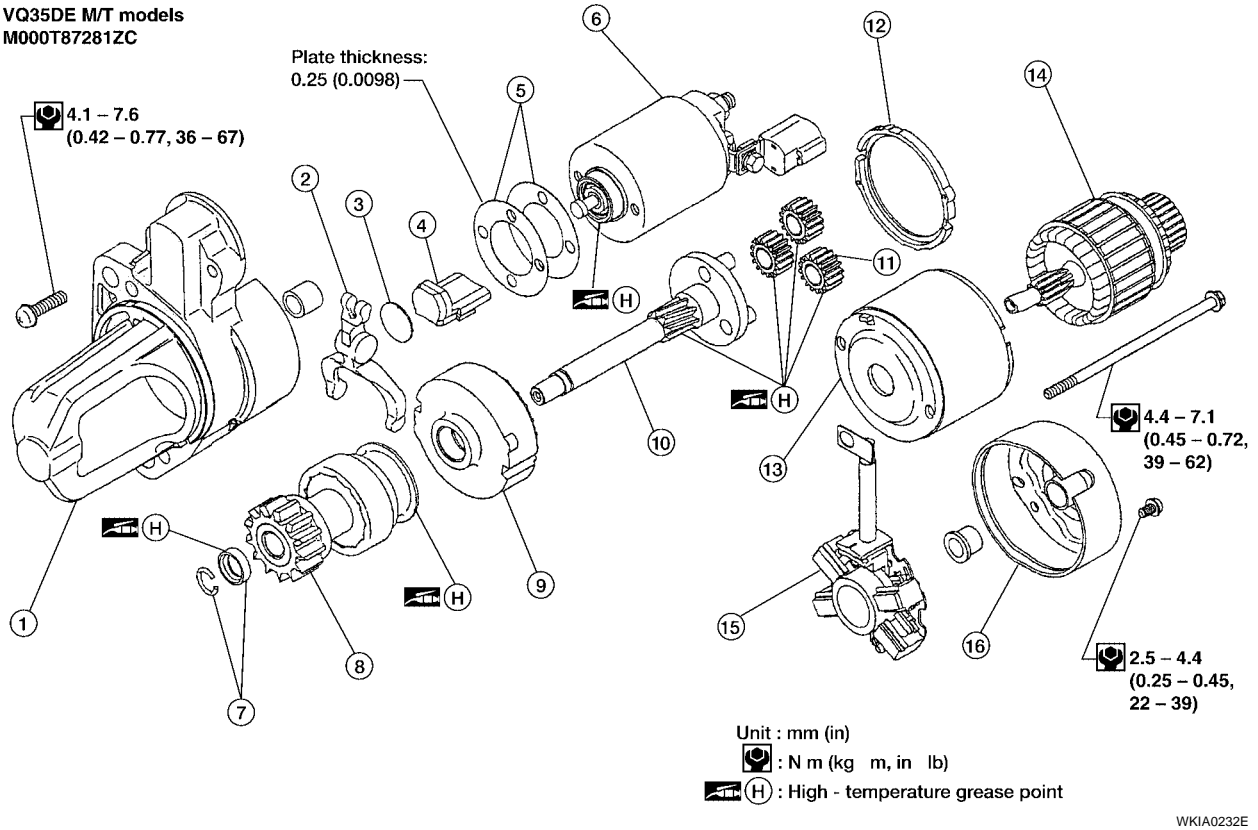

WKIA0232E

- | | | |
|-----------------------|--------------------|-----------------------------|
| 1. Gear case | 2. Shift lever | 3. Plate |
| 4. Packing | 5. Adjusting plate | 6. Magnetic switch assembly |
| 7. Pinion stopper set | 8. Pinion assembly | 9. Internal gear |
| 10. Pinion shaft | 11. Planetary gear | 12. Packing |
| 13. Yoke | 14. Armature | 15. Brush holder assembly |
| 16. Rear cover | | |

STARTING SYSTEM

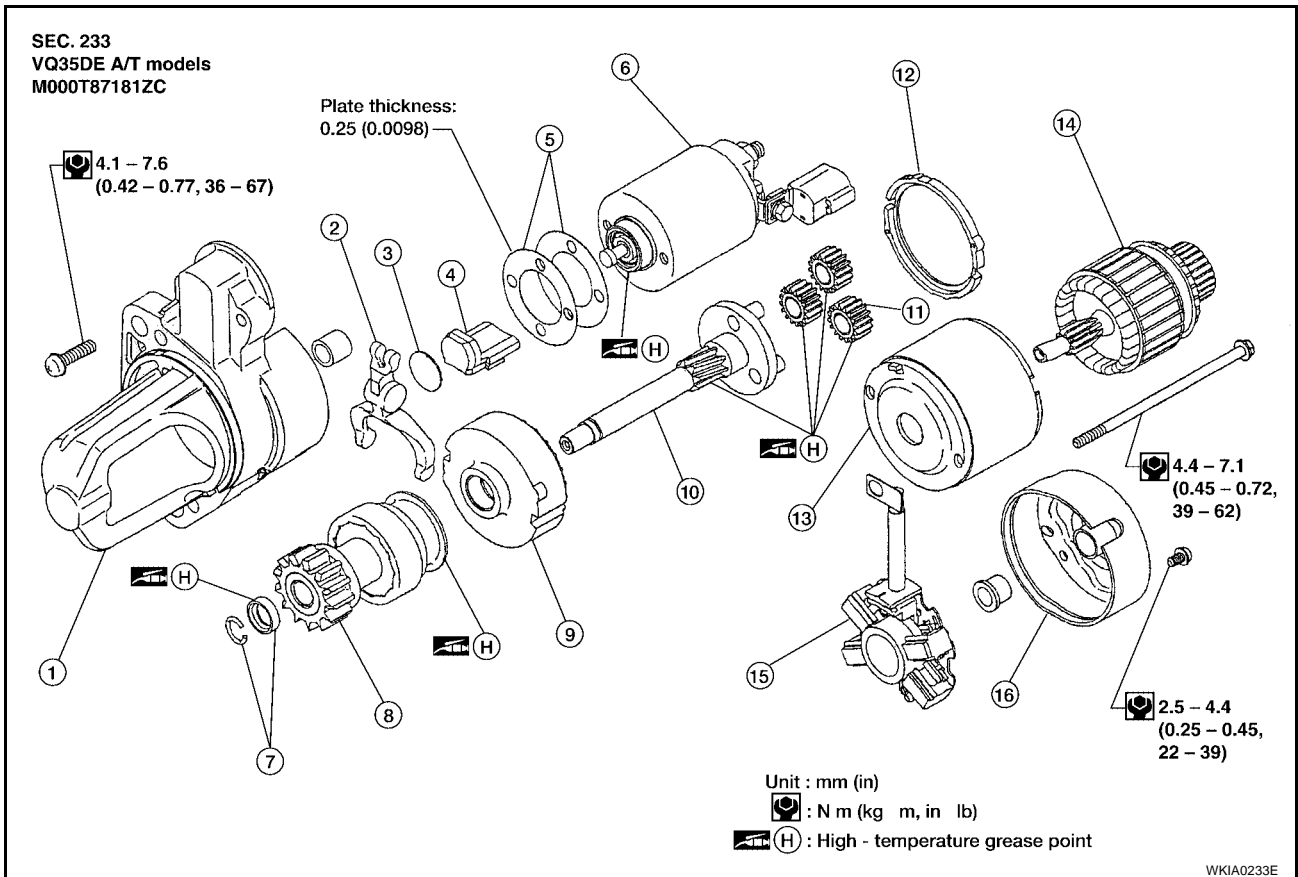

- | | | |
|-----------------------|--------------------|-----------------------------|
| 1. Gear case | 2. Shift lever | 3. Plate |
| 4. Packing | 5. Adjusting plate | 6. Magnetic switch assembly |
| 7. Pinion stopper set | 8. Pinion assembly | 9. Internal gear |
| 10. Pinion shaft | 11. Planetary gear | 12. Packing |
| 13. Yoke | 14. Armature | 15. Brush holder assembly |
| 16. Rear cover | | |

Removal and Installation

REMOVAL

1. Disconnect the negative battery terminal.
2. Remove the air cleaner cover and the air cleaner to intake manifold collector duct (A/T models only).
3. Remove the harness protector from the starter engine room harness.
4. Disconnect the starter harness connectors.
5. Remove the two starter mounting bolts, using power tools.
6. Remove the starter.

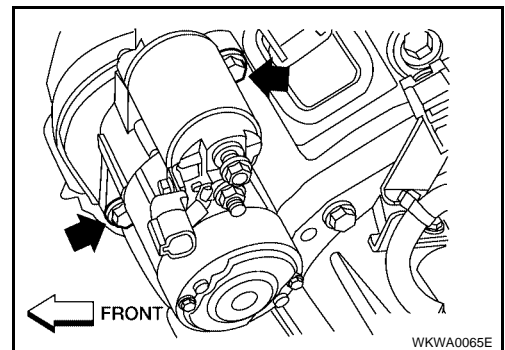

STARTING SYSTEM

Installation

To install, reverse the removal procedure.

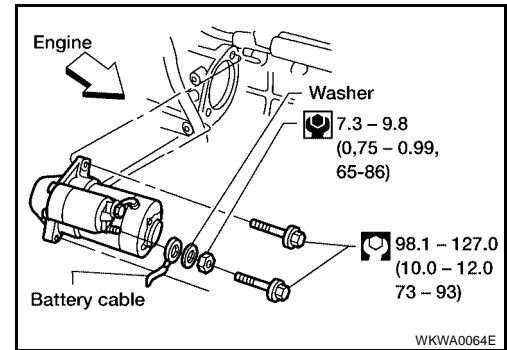

EKS003BQ

Pinion/Clutch Check

1. Inspect pinion assembly teeth.
 - Replace pinion assembly if teeth are worn or damaged. (Also check condition of ring gear teeth.)
2. Inspect planetary gears/planetary gear teeth.
 - Replace planetary gears/planet gears if teeth are worn or damaged. (Also check condition of pinion shaft/drive shaft gear teeth.)
3. Check to see if pinion assembly locks in one direction and rotates smoothly in the opposite direction.
 - If it locks or rotates in both directions, or if unusual resistance is evident, replace.

CHARGING SYSTEM

CHARGING SYSTEM

PFP:23100

System Description

EKS003BR

NOTE:

For vehicles with QR25DE engine, a low tone whistling noise coming from the generator for less than 10 seconds after engine shut down is normal. This is caused by the rotor "slow-down" function. Do not replace the generator exclusively for this symptom.

The generator provides DC voltage to operate the vehicle's electrical system and to keep the battery charged. The voltage output is controlled by the IC regulator.

Power is supplied at all times to generator terminal B through:

- 120A fusible link (letter **a**, located in the fusible link box).

Power is supplied at all times to generator terminal S through:

- 10A fuse (No. 26, located in the fuse and fusible link box).

Terminal B supplies power to charge the battery and operate the vehicle's electrical system. Output voltage is controlled by the IC regulator at terminal S detecting the input voltage. The charging circuit is protected by the 120A fusible link.

The generator is grounded to the engine block.

With the ignition switch in the ON or START position, power is supplied:

- through 10A fuse [No. 14, located in the fuse block (J/B)]
- to combination meter terminals 17 and 18 for the charge warning lamp.

Ground is supplied to terminal 24 of the combination meter through terminal L of the generator. With power and ground supplied, the charge warning lamp will illuminate. When the generator is providing sufficient voltage with the engine running, the ground is opened and the charge warning lamp will go off.

If the charge warning lamp illuminates with the engine running, a fault is indicated.

A

B

C

D

E

F

G

H

I

J

SC

L

M

CHARGING SYSTEM

Wiring Diagram — CHARGE —

EKS003BS

SC-CHARGE-01

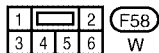
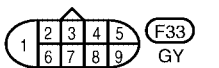
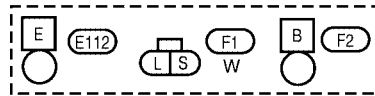
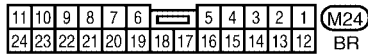
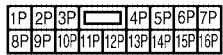
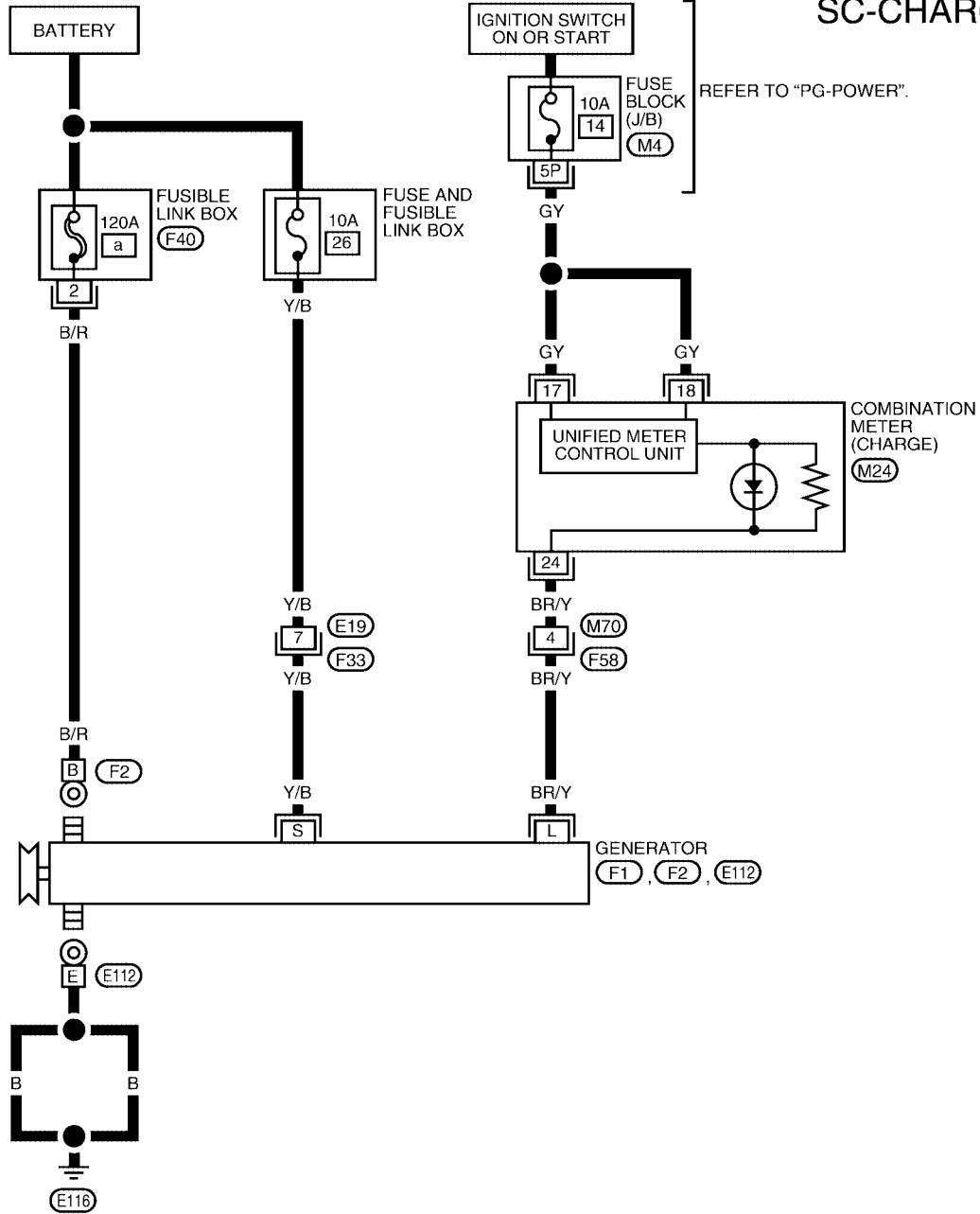

WKWA0158E

CHARGING SYSTEM

Trouble Diagnoses with Battery/Starting/Charging System Tester

EKS003BT

NOTE:

To ensure a complete and thorough diagnosis, the battery, starter and generator test segments must be done as a set from start to finish.

1. Turn off all loads on the vehicle electrical system.
2. Perform battery and starting system test with Battery/Starting/Charging system tester.
3. Press "ENTER" to begin the charging system test.
4. Start engine.

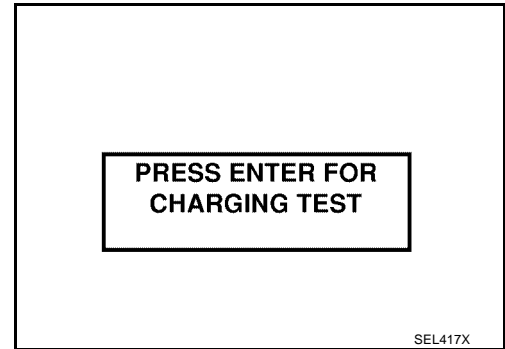

5. Press "ENTER" until "LOADS OFF REV ENGINE 5 SEC" is displayed.
6. Raise and hold the engine speed at 1,500 to 2,000 rpm for about 5 seconds, then return the engine to idle. Once the increase in engine rpm is detected, press "ENTER" to continue.

NOTE:

- If after 30 seconds an increase in engine idle speed is not detected, "RPM NOT DETECTED" will display.
- Some engines may have a higher idle initially after starting, particularly when the engine is cold. The tester may detect this without any other action being taken. If this occurs, continue on with the testing process. The final results will not be affected.

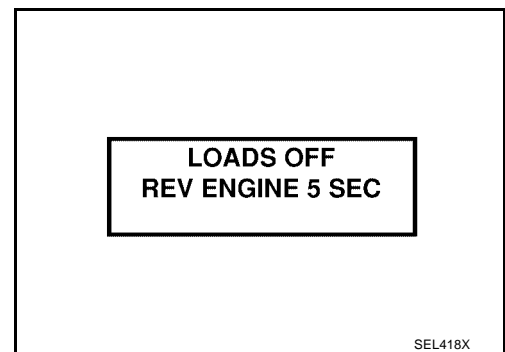

7. The tester now checks the engine at idle and performs the DIODE/RIPPLE check.
8. When complete, the tester will prompt you to turn on the following electrical loads.
 - Heater fan set to highest speed. Do not run the A/C or windshield defroster.
 - Headlamp high beam
 - Rear window defogger

NOTE:

Do not run the windshield wipers or any other cyclical loads.

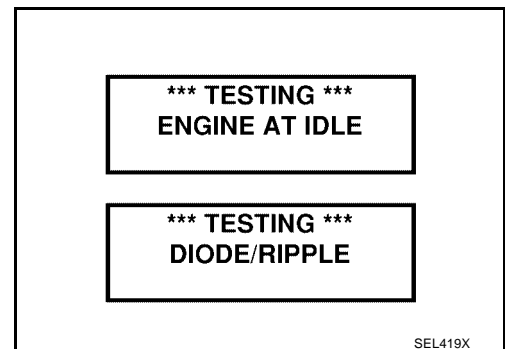

9. Press "ENTER" to continue.

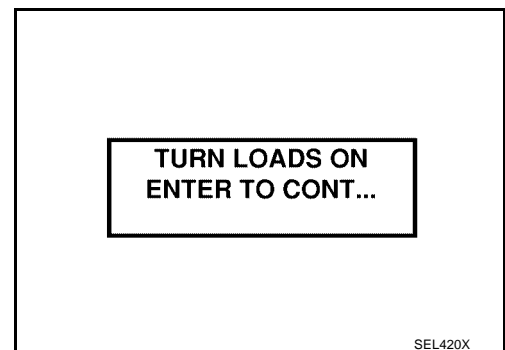

A
B
C
D
E
F
G
H
I
J
SC
L
M

CHARGING SYSTEM

10. Raise and hold the engine speed at 1,500 to 2,000 rpm for about 5 seconds, then return the engine to idle. Once the increase in engine rpm is detected, press "ENTER" to continue.

NOTE:

If after 30 seconds an increase in engine idle speed is not detected, "RPM NOT DETECTED" will be displayed. Press "ENTER" to restart the test.

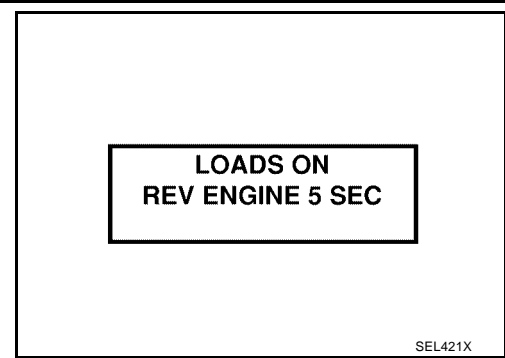

11. Diagnostic result is displayed on the tester. Refer to [SC-28, "DIAGNOSTIC RESULT ITEM CHART"](#) .

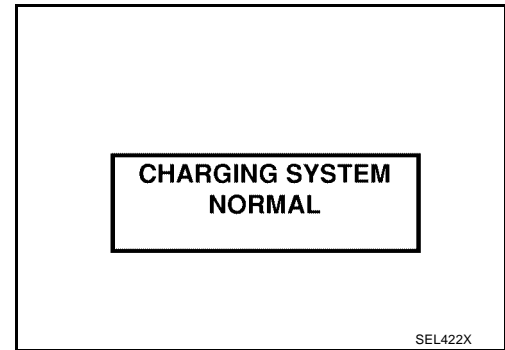

12. Press "ENTER" then test output code is displayed. Record the test output code on the repair order.
 13. Toggle back to the "DIAGNOSTIC SCREEN" for test results.

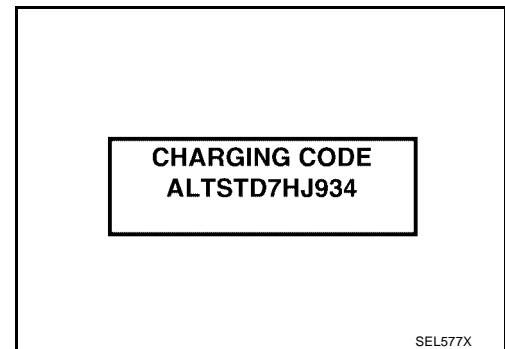

DIAGNOSTIC RESULT ITEM CHART

Diagnostic item	Service procedure
CHARGING SYSTEM NORMAL	Charging system is normal and will also show DIODE RIPPLE test result.
NO CHARGING VOLTAGE	Go to SC-29, "WORK FLOW" .
LOW CHARGING VOLTAGE	Go to SC-29, "WORK FLOW" .
HIGH CHARGING VOLTAGE	Go to SC-29, "WORK FLOW" .
DIODE RIPPLE NORMAL	Diode ripple is OK and will also show CHARGING VOLTAGE test result.
EXCESS RIPPLE DETECTED	Replace the generator. Perform "DIODE RIPPLE" test again using Battery/Starting/Charging system tester to confirm repair.
DIODE RIPPLE NOT DETECTED	Go to SC-29, "WORK FLOW" .

CHARGING SYSTEM

WORK FLOW

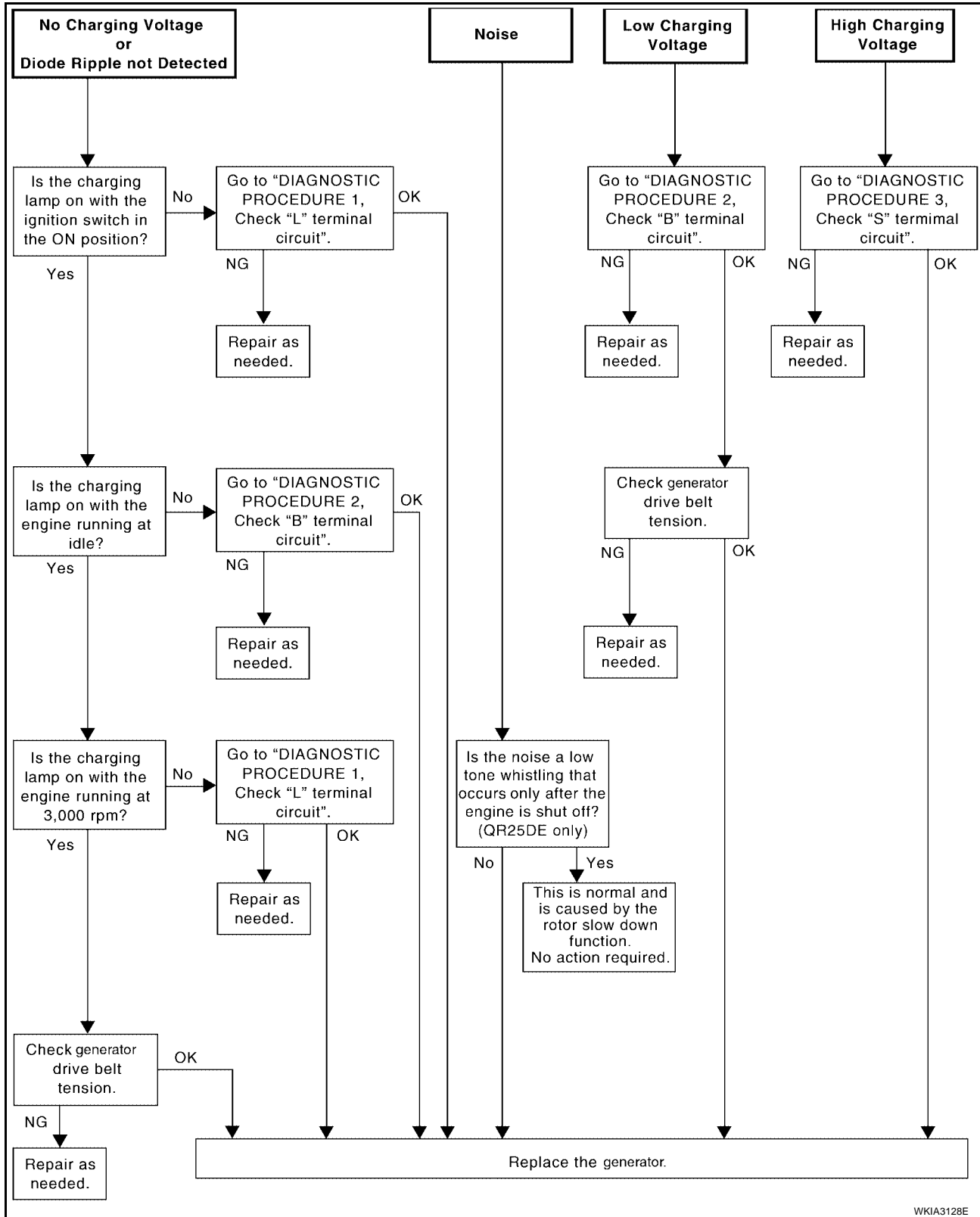

WKIA3128E

A
B
C
D
E
F
G
H
I
J
SC
L
M

CHARGING SYSTEM

DIAGNOSTIC PROCEDURE 1

Check "L" Terminal Circuit

1. CHECK "L" TERMINAL CONNECTION

Check to see if "L" terminal is clean and tight.

OK or NG

OK >> GO TO 2.

NG >> Repair "L" terminal connection. Confirm repair by performing complete Battery/Starting/Charging system test.

2. CHECK "L" TERMINAL CIRCUIT

1. Disconnect F1 connector from generator.
2. Apply ground to connector F1 terminal L (BR/Y) with the ignition switch in the ON position.

CHARGE lamp should light up.

OK or NG

OK >> Replace the generator. Confirm repair by performing complete Battery/Starting/Charging system test.

NG >> Check the following.

- 10A fuse [No. 14, located in fuse block (J/B)]
- CHARGE lamp
- Harness for open or short between combination meter and fuse
- Harness for open or short between combination meter and generator

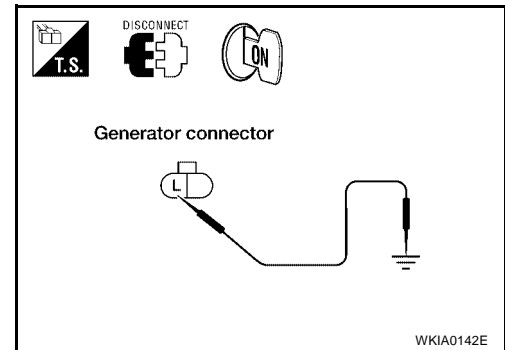

CHARGING SYSTEM

DIAGNOSTIC PROCEDURE 2

Check "B" Terminal Circuit

1. CHECK "B" TERMINAL CONNECTION

Check to see if "B" terminal is clean and tight.

OK or NG

- OK >> GO TO 2. Confirm repair by performing complete Battery/Starting/Charging system test.
NG >> Repair "B" terminal connection.

2. CHECK GENERATOR "B" TERMINAL CIRCUIT

Check voltage between generator connector F2 terminal B (B/R) and ground using a digital circuit tester.

Battery voltage should exist.

OK or NG

- OK >> GO TO 3.
NG >> Check the following.
- 120A fusible link (letter **a** , located in fusible link box)
 - Harness for open or short between generator and fusible link

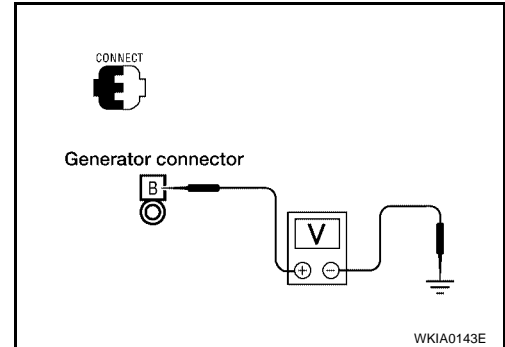

3. CHECK "B" TERMINAL CONNECTION QUALITY (VOLTAGE DROP TEST)

Check voltage between generator connector F2 terminal B (B/R) and battery positive terminal using a digital tester.

With engine running : Less than 0.2V at idle and warm

OK or NG

- OK >> Replace the generator. Confirm repair by performing complete Battery/Starting/Charging system test.
NG >> Check harness between the battery and the generator for poor continuity.

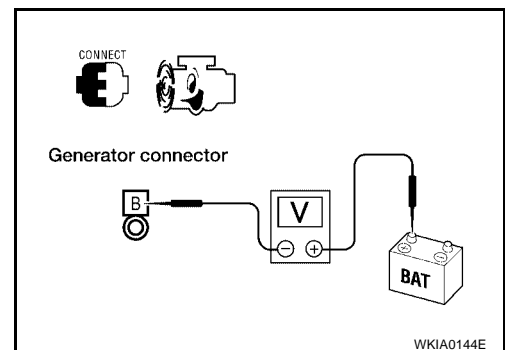

CHARGING SYSTEM

DIAGNOSTIC PROCEDURE 3

Check "S" Terminal Circuit

1. CHECK "S" TERMINAL CONNECTION

Check to see if "S" terminal is clean and tight.

OK or NG

OK >> GO TO 2.

NG >> Repair "S" terminal connection. Confirm repair by performing complete Battery/Starting/Charging system test.

2. CHECK GENERATOR "S" TERMINAL CIRCUIT

Check voltage between generator connector F1 terminal S (Y/B) and ground using a digital circuit tester.

Battery voltage should exist.

OK or NG

OK >> GO TO 3.

NG >> Check the following.

- 10A fuse (No. 26, located in fuse and fusible link box)
- Harness for open or short between generator and fuse

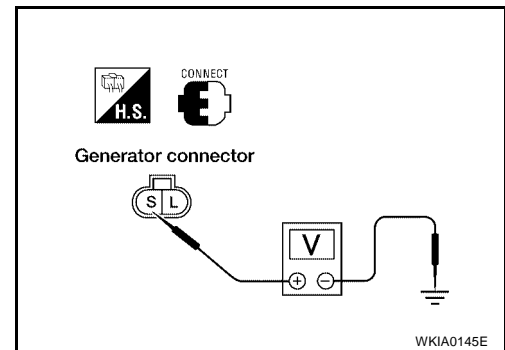

3. CHECK "S" TERMINAL CONNECTION QUALITY (VOLTAGE DROP TEST)

Check voltage between generator connector F1 terminal S (Y/B) and battery positive terminal using a digital tester.

**With engine running : Less than 0.2V
at idle and warm**

OK or NG

OK >> Replace the generator. Confirm repair by performing complete Battery/Starting/Charging system test.

NG >> Check harness between the battery and the generator for poor continuity.

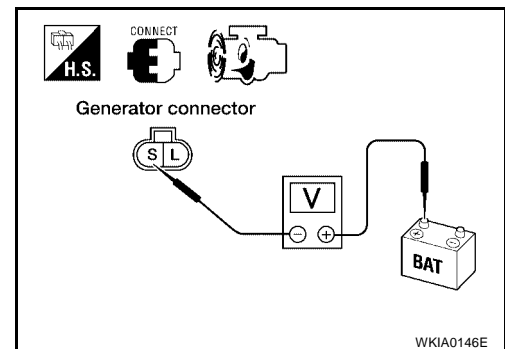

CHARGING SYSTEM

MALFUNCTION INDICATOR

The IC regulator warning function activates to illuminate "CHARGE" warning lamp, if any of the following symptoms occur while generator is operating:

- Excessive voltage is produced.
- No voltage is produced.

Construction

EKS003BU

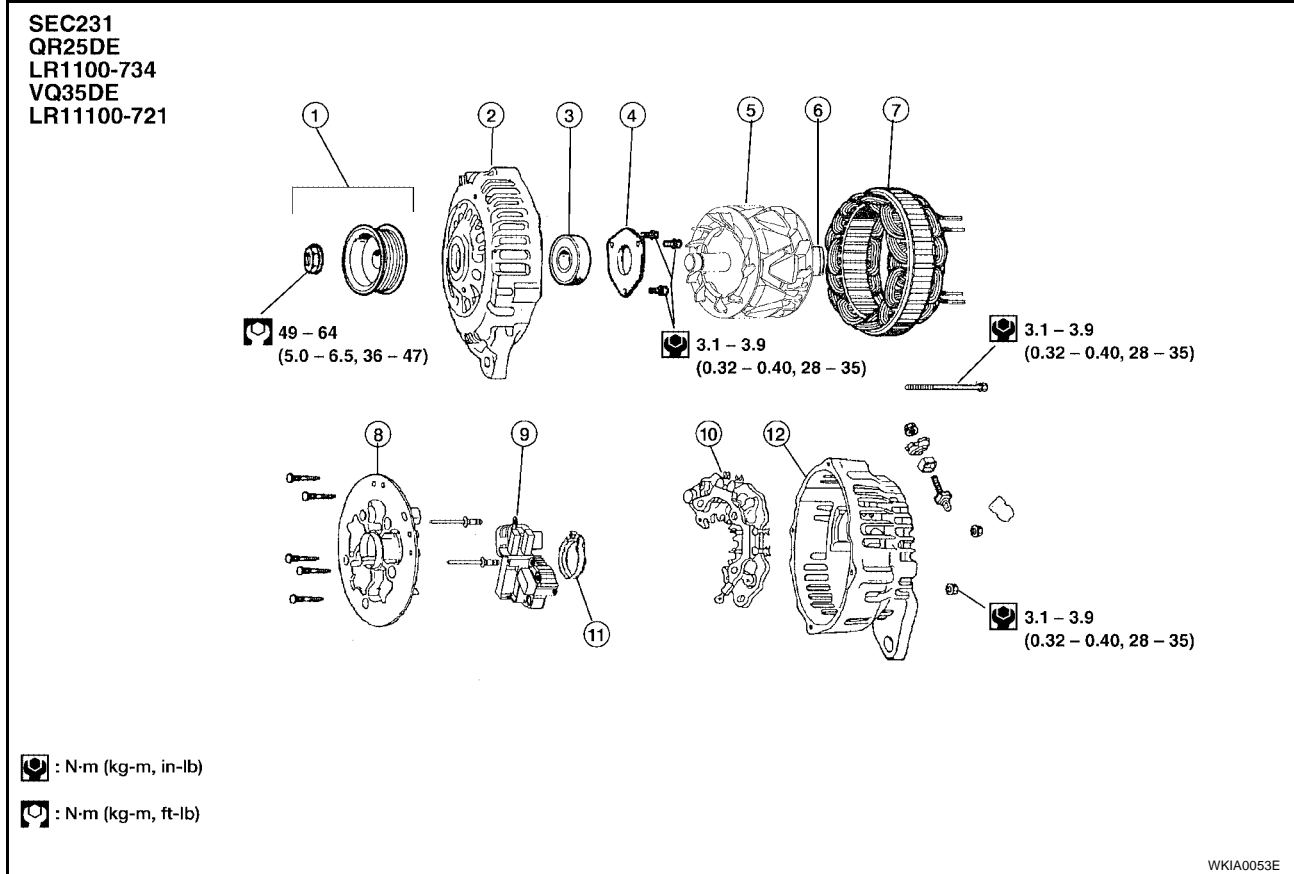

WKIA0053E

- | | | |
|--------------------|----------------|--------------------------|
| 1. Pulley assembly | 2. Front cover | 3. Front bearing |
| 4. Retainer | 5. Rotor | 6. Slip ring |
| 7. Stator | 8. Fan guide | 9. IC regulator assembly |
| 10. Diode assembly | 11. Packing | 12. Rear cover |

Removal and Installation

QR25DE

EKS003BV

NOTE:

A low tone whistling noise coming from the generator for less than 10 seconds after engine shut down is normal. This is caused by the rotor "slow-down" function. Do not replace the generator exclusively for this symptom.

Removal

1. Disconnect the negative battery terminal.
2. Remove the engine cover.
3. Remove the front/right-side engine undercover, using power tools.
4. Remove the drive belt. Refer to [EM-13, "Removal and Installation"](#).
5. Disconnect the generator harness connector.
6. Disconnect the engine ground wire from top mount.

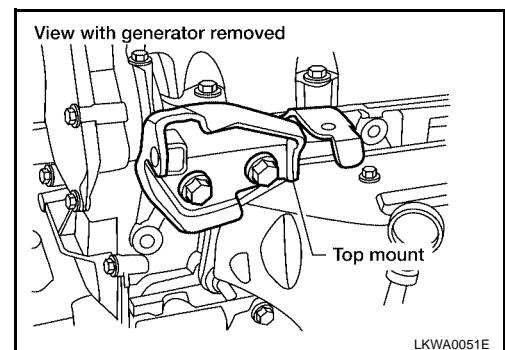

LKWA0051E

CHARGING SYSTEM

7. Remove the generator upper and lower mounting bolts, using power tools.
8. Set the generator aside and remove the generator top mount.
9. Slide the generator out and remove.

Installation

To install, reverse the removal procedure.

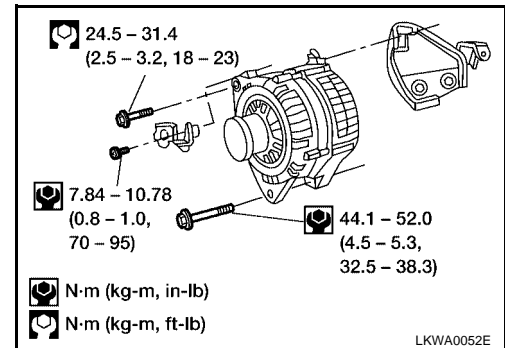

VQ35DE

Removal

1. Disconnect the negative battery terminal.
2. Remove radiator, refer [EC-1078, "Component Description"](#) .
3. Remove front/right-side engine under cover
4. Remove the drive belt, refer to [EM-118, "DRIVE BELTS"](#) .
5. Remove idler pulley.
6. Remove the generator adjustable top mount, using power tools.
7. Remove the generator lower mount bolt and nuts, using power tools.
8. Remove the generator lower front bracket bolt, using power tools.
9. Disconnect the generator harness connectors.
10. Slide the generator out and remove.

Installation

To install, reverse the removal procedure.

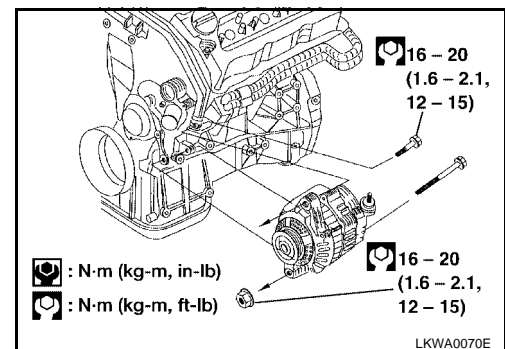

SERVICE DATA AND SPECIFICATIONS (SDS)

SERVICE DATA AND SPECIFICATIONS (SDS)

PF0:00030

Battery

EKS003BW

Type	GR.24F (BCI)
Capacity (20 HR) minimum V-AH	12-63
Cold cranking current A (For reference value)	550 @ -18°C (0°F)

Starter

EKS003BX

Application	QR25DE		VQ35DE	
	M/T model	A/T model	M/T model	A/T model
Manufacturer	Mitsubishi M000T87085ZC	Mitsubishi M000T60781ZC	Mitsubishi M000T87281ZC	Mitsubishi M000T87181ZC
Type	Reduction gear type			
System voltage	12V			
No-load	Terminal voltage	11V		
	Current	90A Max.		
	Revolution	2,500 rpm Min.	2,800 rpm Min.	
Minimum diameter of commutator	28.8 mm			
Minimum length of brush	5.5mm	7.0 mm		
Brush spring tension	15.0-20.4 N (1.53-2.08 kg, 3.37-4.59 lb)	18.3-24.8 N (1.87-2.53 kg, 4.11-5.58 lb)		
Clearance between pinion front edge and pinion stopper	0.5-2.0 mm			

Generator

EKS003BY

Application	QR25DE	VQ35DE
Type	LR1100-734	LR1100-721
	HITACHI	
Nominal rating	12V-110A	
Ground polarity	Negative	
Minimum revolution under no-load (When 13.5 volts is applied)	950 rpm	1100 rpm
Hot output current (When 13.5 volts is applied)	More than 35A/1,300 rpm More than 83A/2,500 rpm More than 95A/5,000 rpm	More than 35A/1,300 rpm More than 91A/2,500 rpm More than 110A/5,000 rpm
Regulated output voltage	14.1 - 14.7V	
Minimum length of brush	6 mm (0.236 in)	
Brush spring pressure	1.000 - 3.432 N (0.102 - 0.350 kg, 0.225 - 0.772 lbs)	
Slip ring minimum outer diameter	26.0 mm (1.024 in)	
Rotor (Field coil) resistance	2.31 ohms	

SERVICE DATA AND SPECIFICATIONS (SDS)
