

SECTION **SRS**

SUPPLEMENTAL RESTRAINT SYSTEM (SRS)

A
B
C
D
E
F
G
H
I
J
K
L
M

CONTENTS

PRECAUTIONS	3	DIAGNOSTIC PROCEDURE 5	27
Precautions for Supplemental Restraint System (SRS) "AIR BAG" and "SEAT BELT PRE-TENSIONER"	3	Trouble diagnoses without CONSULT-II.	32
Precautions for SRS "AIR BAG" and "SEAT BELT PRE-TENSIONER" Service	3	DIAGNOSTIC PROCEDURE 6	32
Trouble Diagnosis Precaution	3	WARNING LAMP FLASH CODE CHART	33
PREPARATION	4	Trouble Diagnoses: "AIR BAG" Warning Lamp Does Not Turn Off	37
Special Service Tool	4	DIAGNOSTIC PROCEDURE 6	37
SUPPLEMENTAL RESTRAINT SYSTEM (SRS)	5	Trouble Diagnoses: "AIR BAG" Warning Lamp Does Not Turn On	38
SRS Configuration	5	DIAGNOSTIC PROCEDURE 7	38
Front Seat Belt Pre-tensioner with Load Limiter	6	DRIVER AIR BAG MODULE	39
Front Side Air Bag	6	Removal and Installation	39
Side Curtain Air Bag	6	REMOVAL	39
Direct-connect SRS Component Connectors	7	INSTALLATION	40
TROUBLE DIAGNOSIS	8	SPIRAL CABLE	41
Trouble Diagnoses Introduction	8	Removal and Installation	41
DIAGNOSIS FUNCTION	8	REMOVAL	41
HOW TO PERFORM TROUBLE DIAGNOSES FOR QUICK AND ACCURATE REPAIR	8	INSTALLATION	42
WORK FLOW	9	FRONT PASSENGER AIR BAG MODULE	43
SRS Components Parts Location	10	Removal and Installation	43
Schematic	11	REMOVAL	43
Wiring Diagram-SRS-	12	INSTALLATION	44
CONSULT-II FUNCTION	17	WIRING HARNESS MODIFICATION	44
DIAGNOSIS MODE FOR CONSULT-II	17	FRONT SIDE AIR BAG MODULE	47
HOW TO CHANGE SELF-DIAGNOSIS MODE WITH CONSULT-II	17	Removal	47
HOW TO ERASE SELF-DIAGNOSIS RESULTS..	18	SIDE CURTAIN AIR BAG MODULE	48
SELF-DIAGNOSIS FUNCTION (WITHOUT CONSULT-II)	18	Removal and Installation	48
HOW TO CHANGE SELF-DIAGNOSIS MODE..	18	REMOVAL	48
HOW TO ERASE SELF-DIAGNOSIS RESULTS..	18	INSTALLATION	49
SRS Operation Check	19	CRASH ZONE SENSOR	50
DIAGNOSTIC PROCEDURE 1	19	Removal and Installation	50
Trouble Diagnoses with CONSULT-II	21	REMOVAL	50
DIAGNOSTIC PROCEDURE 2	21	INSTALLATION	50
DIAGNOSTIC PROCEDURE 3	25	SIDE AIR BAG (SATELLITE) SENSOR	51
DIAGNOSTIC PROCEDURE 4 (CONTINUED FROM DIAGNOSTIC PROCEDURE 2)	27	Removal and Installation	51
		REMOVAL	51
		INSTALLATION	51
		FRONT SEAT BELT PRE-TENSIONER	52
		Removal and Installation	52

SRS

DIAGNOSIS SENSOR UNIT	53	MOUNTED IN VEHICLE	60
Removal and Installation	53	DISPOSING OF AIR BAG MODULE AND SEAT	
REMOVAL	53	BELT PRE-TENSIONER	60
INSTALLATION	53	COLLISION DIAGNOSIS	61
ECU DISCRIMINATED NO.	53	For Frontal Collision	61
DISPOSAL OF AIR BAG MODULE AND SEAT BELT		WHEN SRS (EXCEPT THE FRONT SIDE AIR	
PRE-TENSIONER	54	BAG AND SIDE CURTAIN AIR BAG MODULES)	
Caution for Air Bag Module and Seat Belt Pre-tensioner	54	IS ACTIVATED IN A COLLISION	61
CHECKING DEPLOYMENT TOOL	54	WHEN SRS IS NOT ACTIVATED IN A COLLISION	61
DEPLOYMENT PROCEDURES FOR AIR BAG MODULE (OUTSIDE OF VEHICLE)	55	SRS INSPECTION (FOR FRONTAL COLLISION)	61
DEPLOYMENT PROCEDURES FOR SEAT BELT PRE-TENSIONER (OUTSIDE OF VEHICLE)	59	For Side Collision	62
DEPLOYMENT OF AIR BAG MODULE AND SEAT BELT PRE-TENSIONER WHILE		WHEN SRS IS ACTIVATED IN THE SIDE COLLISION	62
		WHEN SRS IS NOT ACTIVATED IN THE SIDE COLLISION	62
		SRS INSPECTION (FOR SIDE COLLISION)	63

PRECAUTIONS

PRECAUTIONS

PFP:00001

Precautions for Supplemental Restraint System (SRS) “AIR BAG” and “SEAT BELT PRE-TENSIONER”

EHS000LF

The Supplemental Restraint System such as “AIR BAG” and “SEAT BELT PRE-TENSIONER”, used along with a front seat belt, helps to reduce the risk or severity of injury to the driver and front passenger for certain types of collision. This system includes seat belt switch inputs and dual stage front air bag modules. The SRS system uses the seat belt switches to determine the front air bag deployment, and may only deploy one front air bag, depending on the severity of a collision and whether the front occupants are belted or unbelted. Information necessary to service the system safely is included in the SRS and SB section of this Service Manual.

WARNING:

- To avoid rendering the SRS inoperative, which could increase the risk of personal injury or death in the event of a collision which would result in air bag inflation, all maintenance must be performed by an authorized NISSAN/INFINITI dealer.
- Improper maintenance, including incorrect removal and installation of the SRS, can lead to personal injury caused by unintentional activation of the system. For removal of Spiral Cable and Air Bag Module, see the SRS section.
- Do not use electrical test equipment on any circuit related to the SRS unless instructed to in this Service Manual. SRS wiring harnesses can be identified by yellow and/or orange harness connectors.

Precautions for SRS “AIR BAG” and “SEAT BELT PRE-TENSIONER” Service

EHS000KH

- Do not use electrical test equipment to check SRS circuits unless instructed to in this Service Manual.
- Before servicing the SRS, turn ignition switch OFF, disconnect both battery cables and wait at least 3 minutes.
For approximately 3 minutes after the cables are removed, it is still possible for the air bag and seat belt pre-tensioner to deploy. Therefore, do not work on any SRS connectors or wires until at least 3 minutes have passed.
- The diagnosis sensor unit must always be installed with the arrow mark “←” pointing toward the front of the vehicle for proper operation. Also check diagnosis sensor unit for cracks, deformities or rust before installation and replace as required.
- The spiral cable must be aligned with the neutral position since its rotations are limited. Do not attempt to turn steering wheel or column after removal of steering gear.
- Handle air bag module carefully. Always place driver and front passenger air bag modules with the pad side facing upward and seat mounted front side air bag module standing with the stud bolt side facing down.
- Conduct self-diagnosis to check entire SRS for proper function after replacing any components.
- After air bag inflates, the front instrument panel assembly should be replaced if damaged.

Trouble Diagnosis Precaution

EHS000KI

When you read wiring diagrams, refer to the following:

- [GI-12, "How to Read Wiring Diagrams"](#) in GI section
- [PG-3, "POWER SUPPLY ROUTING CIRCUIT"](#) in PG section

When you perform trouble diagnosis, refer to the following:

- [GI-10, "HOW TO FOLLOW TEST GROUPS IN TROUBLE DIAGNOSES"](#) in GI section
- [GI-25, "How to Perform Efficient Diagnosis for an Electrical Incident"](#) in GI section

Check for any service bulletins before servicing the vehicle.

PREPARATION



PFP:00002

EHS000KJ

PREPARATION

Special Service Tool

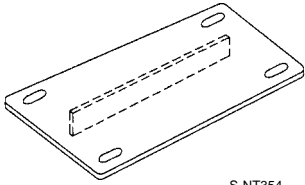
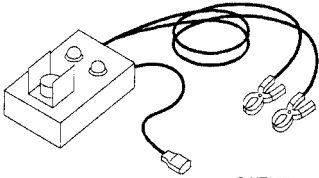
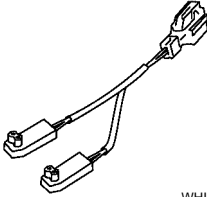
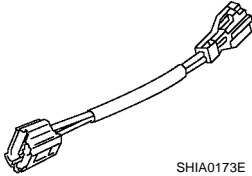
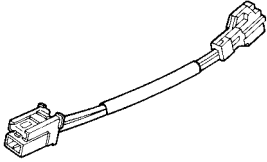
The actual shapes of Kent-Moore tools may differ from those of special service tools illustrated here.

Tool number (Kent-Moore No.) Tool name	Description
KV99105300 (J41246) Air bag module bracket	 <p style="text-align: center;">S-NT354</p>
KV99106400 (J38381) Deployment tool	 <p style="text-align: center;">S-NT357</p>
(J38381-80) Deployment tool adapter for front driver air bag module, side curtain air bag module and front seat belt pre-tensioner	 <p style="text-align: center;">WHIA0089E</p>
(J38381-65) Deployment tool adapter for front passenger air bag module (service replacement)	 <p style="text-align: center;">SHIA0173E</p>
KV99109000 (J44230) Deployment tool adapter for front side air bag module	 <p style="text-align: center;">ZZA1190D</p>
(J44615) Air bag lock master key set	 <p style="text-align: center;">LRS210</p>

SUPPLEMENTAL RESTRAINT SYSTEM (SRS)

SUPPLEMENTAL RESTRAINT SYSTEM (SRS)

PF:28556

SRS Configuration

EHS000KK

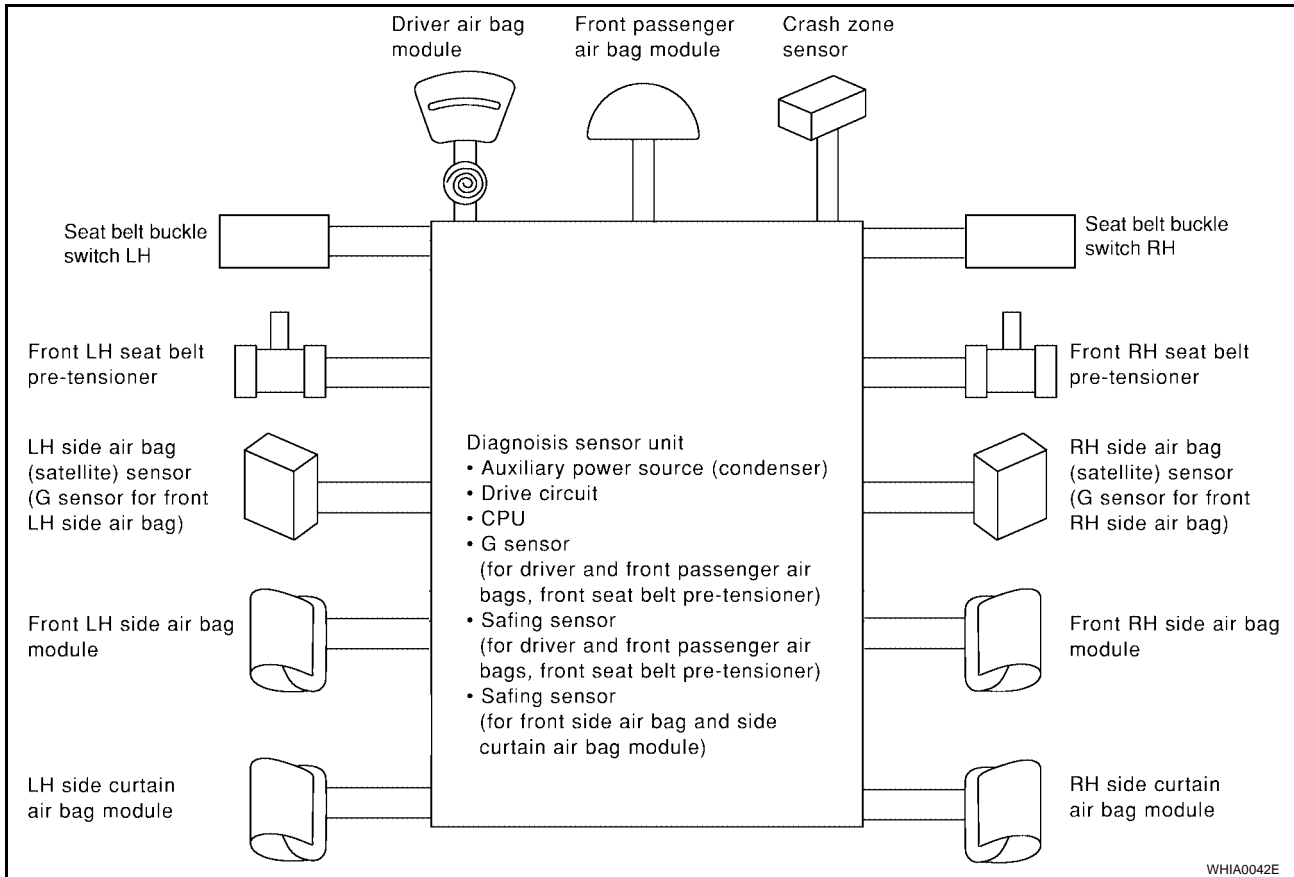

The air bag deploys if the diagnosis sensor unit activates while the ignition switch is in the ON or START position.

The collision modes for which supplemental restraint systems are activated are different among the SRS systems. For example, the driver air bag module and front passenger air bag module are activated in a frontal collision but not in a side collision.

SRS configurations which are activated for some collision modes are as follows;

SRS configuration	Frontal collision	Left side collision	Right side collision
Driver air bag module	×	—	—
Front passenger air bag module	×	—	—
Front LH seat belt pre-tensioner	×	—	—
Front RH seat belt pre-tensioner	×	—	—
Front LH side air bag module	—	×	—
Front RH side air bag module	—	—	×
LH side curtain air bag module	—	×	—
RH side curtain air bag module	—	—	×

SUPPLEMENTAL RESTRAINT SYSTEM (SRS)

Front Seat Belt Pre-tensioner with Load Limiter

EHS000KL

The seat belt pre-tensioner system with load limiter is installed for both the driver's seat and the front passenger's seat. It operates simultaneously with the SRS air bag system in the event of a frontal collision with an impact exceeding a specified level.

When the frontal collision with an impact exceeding a specified level occurs, seat belt slack resulting from clothing or other factors is immediately taken up by the pre-tensioner. Vehicle passengers are securely restrained.

When passengers in a vehicle are thrown forward in a collision and the restraining force of the seat belt exceeds a specified level, the load limiter permits the specified extension of the seat belt by the twisting of the ELR shaft, and a relaxation of the chest-area seat belt web tension while maintaining force.

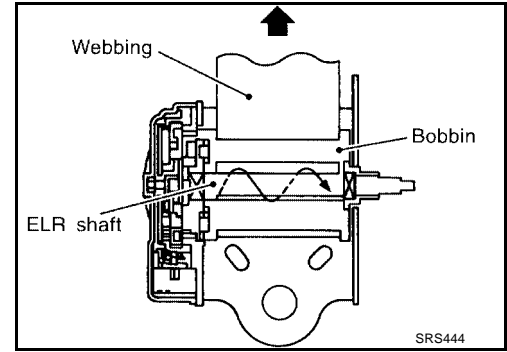

Front Side Air Bag

EHS000KM

Front side air bag is built-in type.

The front seatbacks with built-in type side air bag have the labels as shown.

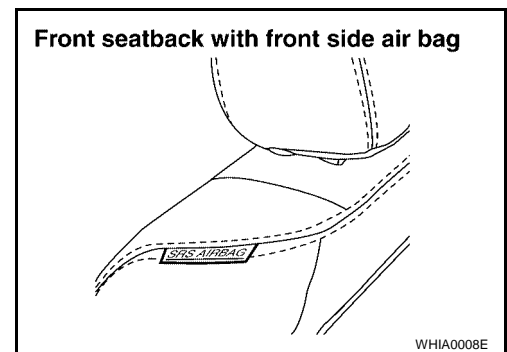

Side Curtain Air Bag

EHS000KN

The side curtain air bags have the labels as shown.



SUPPLEMENTAL RESTRAINT SYSTEM (SRS)

Direct-connect SRS Component Connectors

EHS000LG

The following SRS components use direct-connect style harness connectors.

- Driver air bag module
- Front passenger air bag module
- LH side curtain air bag module
- RH side curtain air bag module
- Front LH seat belt pre-tensioner
- Front RH seat belt pre-tensioner

Always pull up to release black locking tab prior to removing connector from SRS component.

Always push down to lock black locking tab after installing connector to SRS component. When locked, the black locking tab is level with the connector housing.

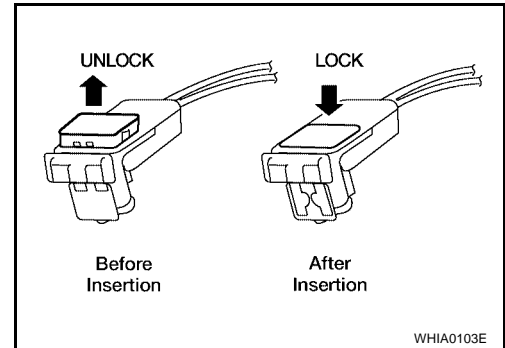

A

B

C

D

E

F

G

SRS

I

J

K

L

M

TROUBLE DIAGNOSIS

TROUBLE DIAGNOSIS

PFP:00004

Trouble Diagnoses Introduction

EHS000KO

CAUTION:

- Do not use electrical test equipment on any circuit related to the SRS unless instructed to in this Service Manual. SRS wiring harnesses can be identified by yellow and/or orange harness connectors.
- Do not attempt to repair, splice or modify the SRS wiring harness. If the harness is damaged, replace it with a new one.
- Keep ground portion clean.

DIAGNOSIS FUNCTION

The SRS self-diagnosis results can be read by using "AIR BAG" warning lamp and/or CONSULT-II.

The User mode is exclusively prepared for the customer (driver). This mode warns the driver of a system malfunction through the operation of the "AIR BAG" warning lamp.

The Diagnosis mode allows the technician to locate and inspect the malfunctioning part.

The mode applications for the "AIR BAG" warning lamp and CONSULT-II are as follows:

	User mode	Diagnosis mode	Display type
"AIR BAG" warning lamp	X	X	ON-OFF operation
CONSULT-II	—	X	Monitoring

HOW TO PERFORM TROUBLE DIAGNOSES FOR QUICK AND ACCURATE REPAIR

A good understanding of the malfunction conditions can make troubleshooting faster and more accurate.

In general, each customer feels differently about a malfunction. It is important to fully understand the symptoms or conditions for a customer complaint.

Information From Customer

WHAT..... Vehicle model

WHEN..... Date, Frequencies

WHERE..... Road conditions

HOW..... Operating conditions, Symptoms

Preliminary Check

Check that the following parts are in good order.

- Battery (Refer to [SC-4, "How to Handle Battery"](#) .)
- Fuse (Refer to [SRS-11, "Schematic"](#) .)
- System component-to-harness connections

TROUBLE DIAGNOSIS

WORK FLOW

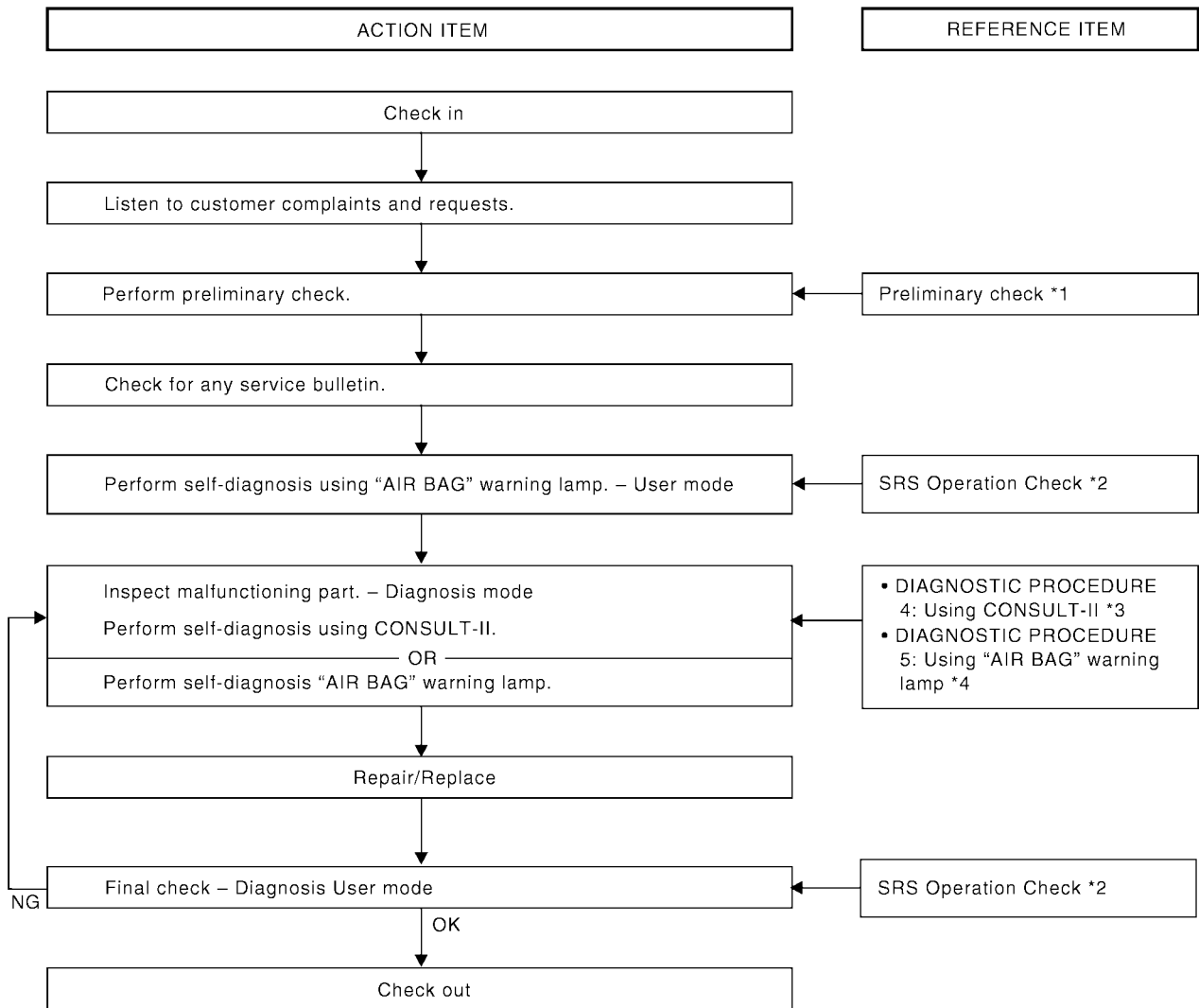

*1: [SRS-8](#)

*2: [SRS-19](#)

*3: [SRS-27](#)

*4: [SRS-27](#)

SHIA0175E

A
B
C
D
E
F
G
SRS
I
J
K
L
M

TROUBLE DIAGNOSIS

SRS Components Parts Location

EHS000KP

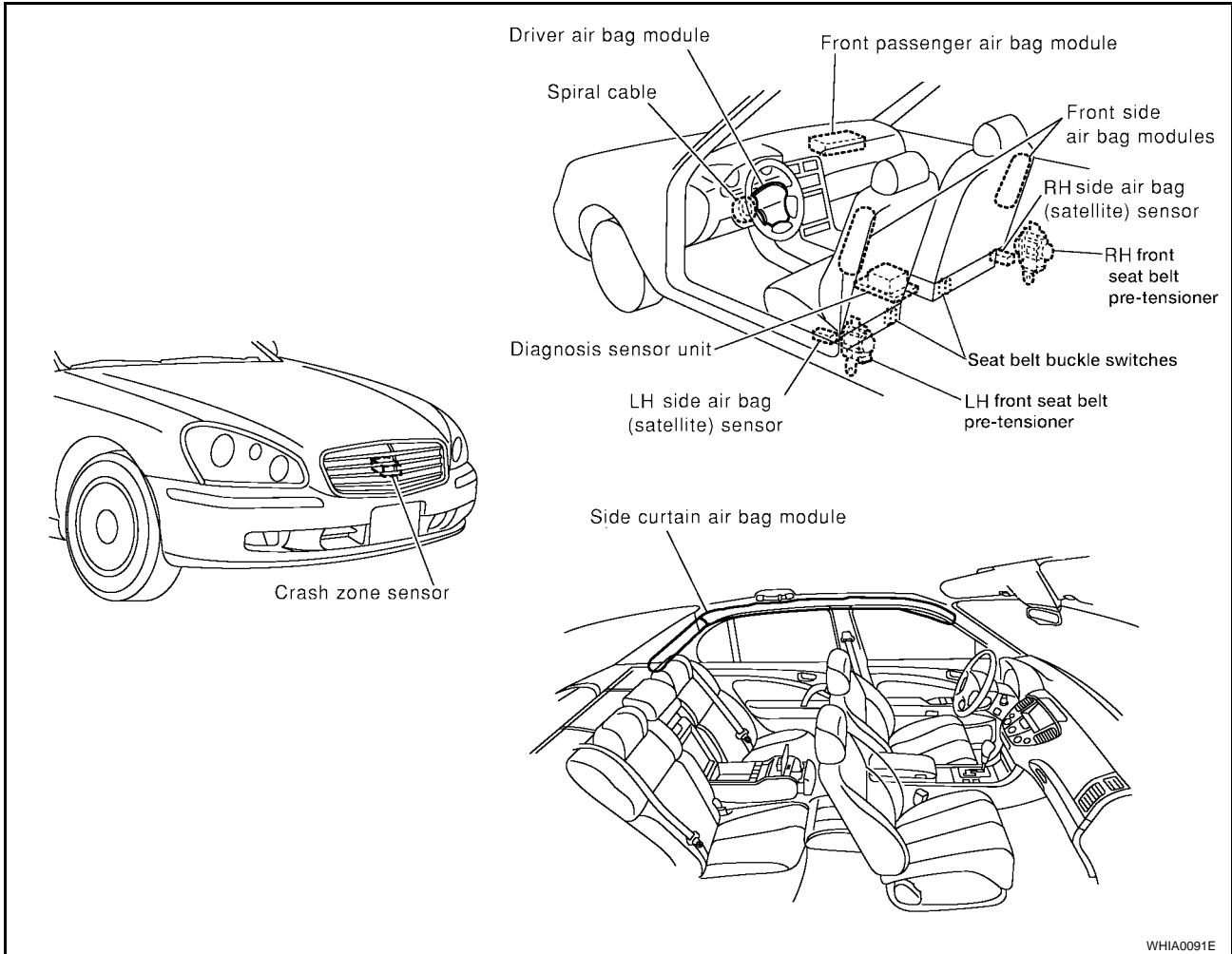

TROUBLE DIAGNOSIS

Schematic

EHS000KQ

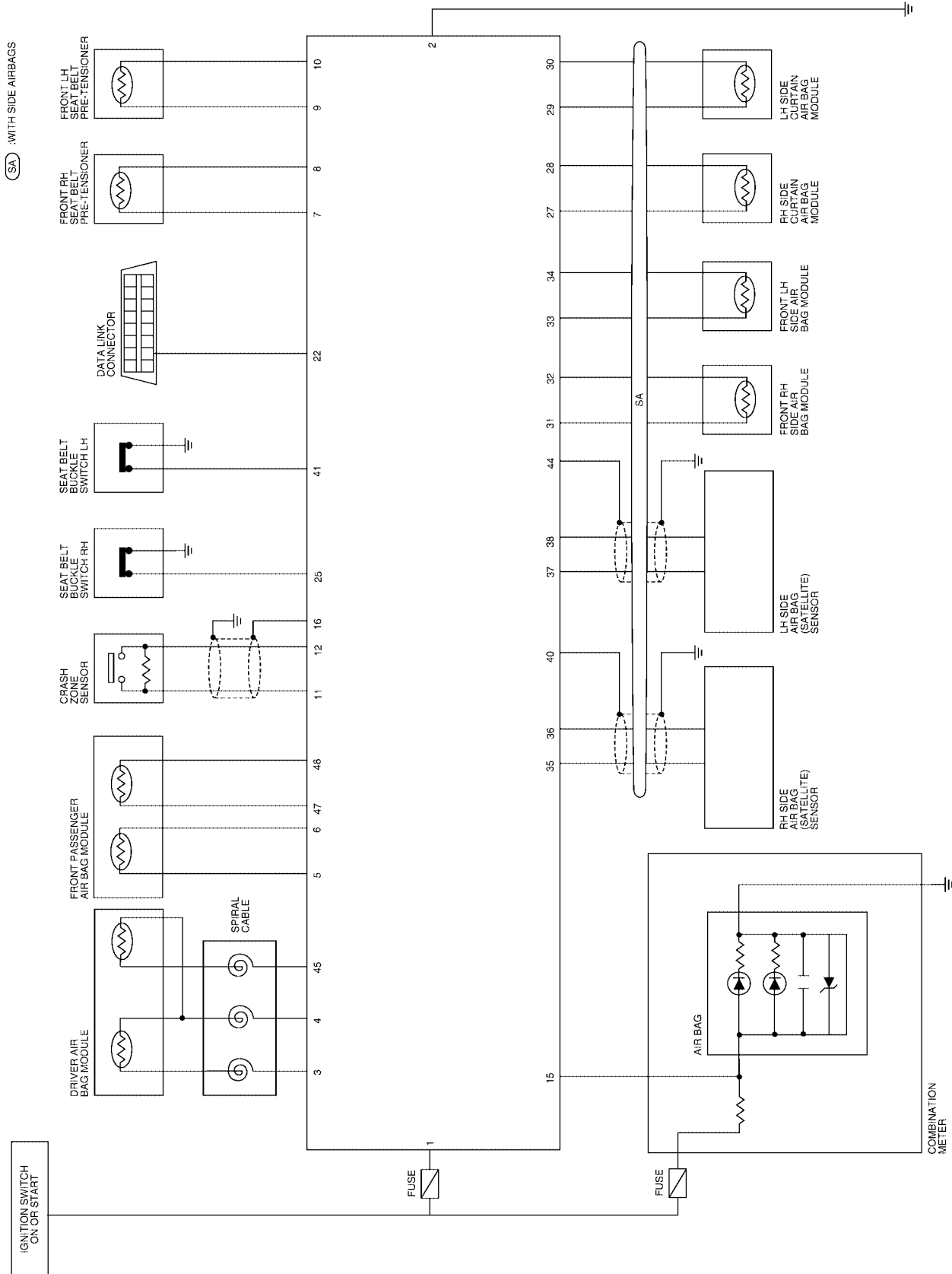

A
B
C
D
E
F
G
H
I
J
K
L
M

SRS

WHWA0017E

TROUBLE DIAGNOSIS

Wiring Diagram-SRS-

EHS000KR

SRS-SRS-01

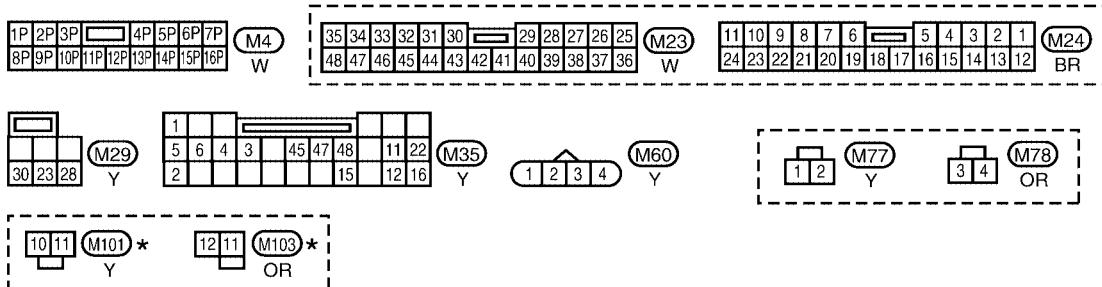
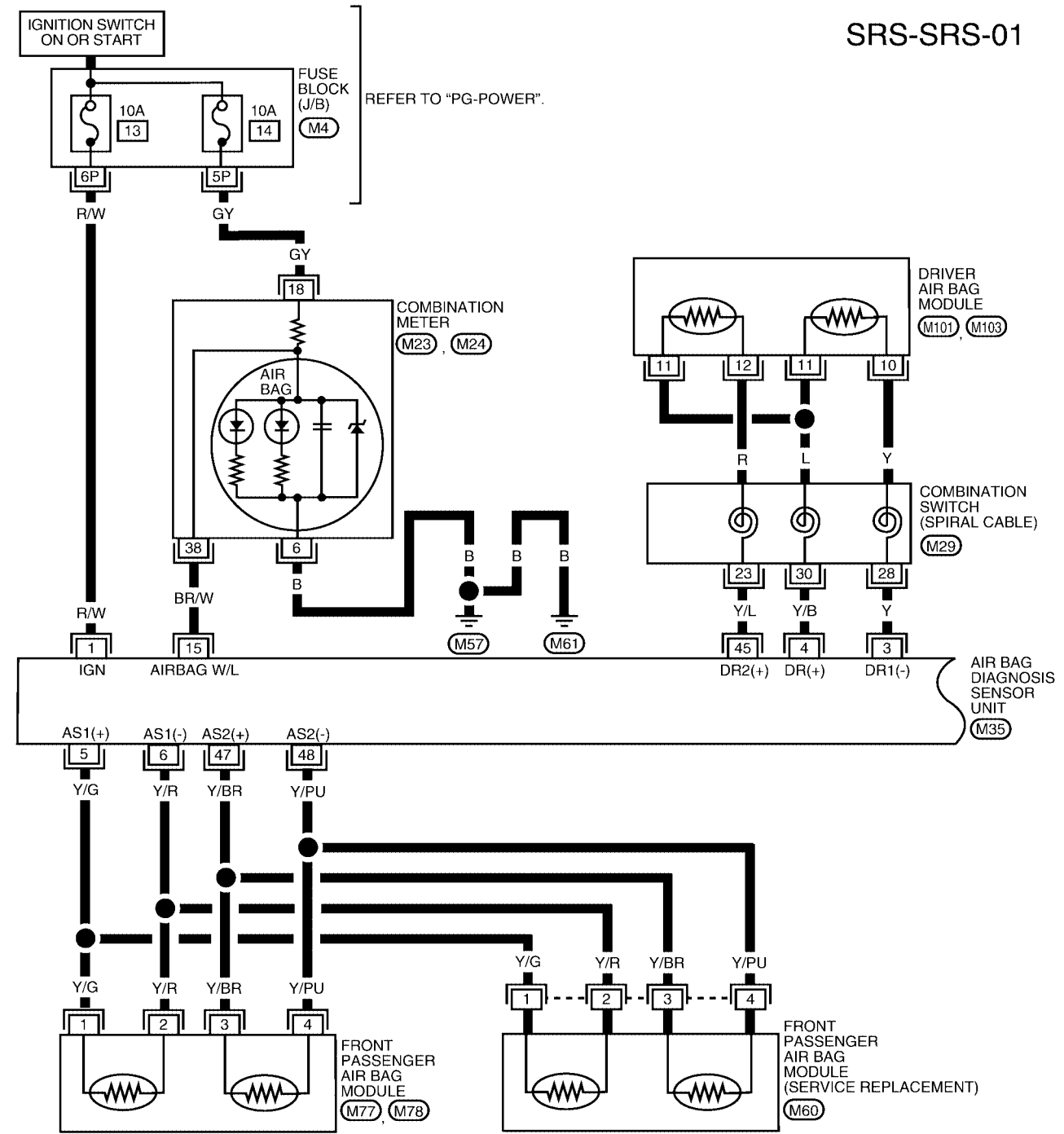

*: THIS CONNECTOR IS NOT SHOWN IN "HARNESS LAYOUT" OF PG SECTION.

WHWA0018E

TROUBLE DIAGNOSIS

SRS-SRS-02

A
B
C
D
E
F
G
H
I
J
K
L
M

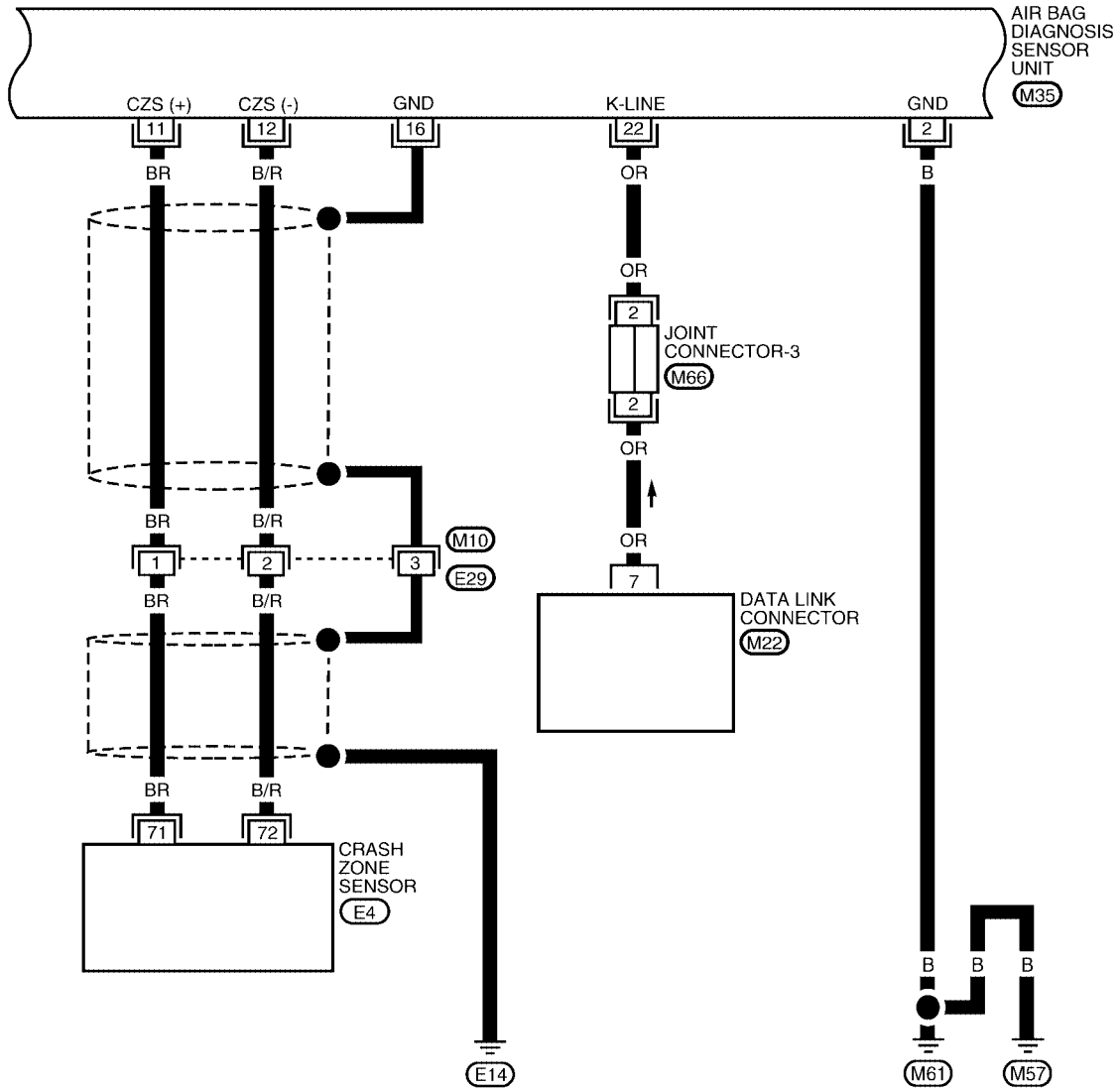

SRS

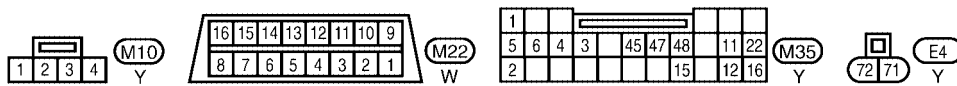

REFER TO THE FOLLOWING.
M66 - JOINT CONNECTOR

WHWA0019E

TROUBLE DIAGNOSIS

SRS-SRS-03

◊SA◊ : WITH SIDE AIR BAGS

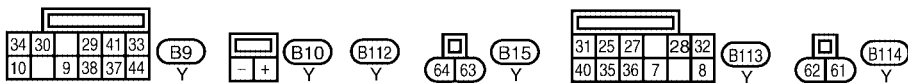
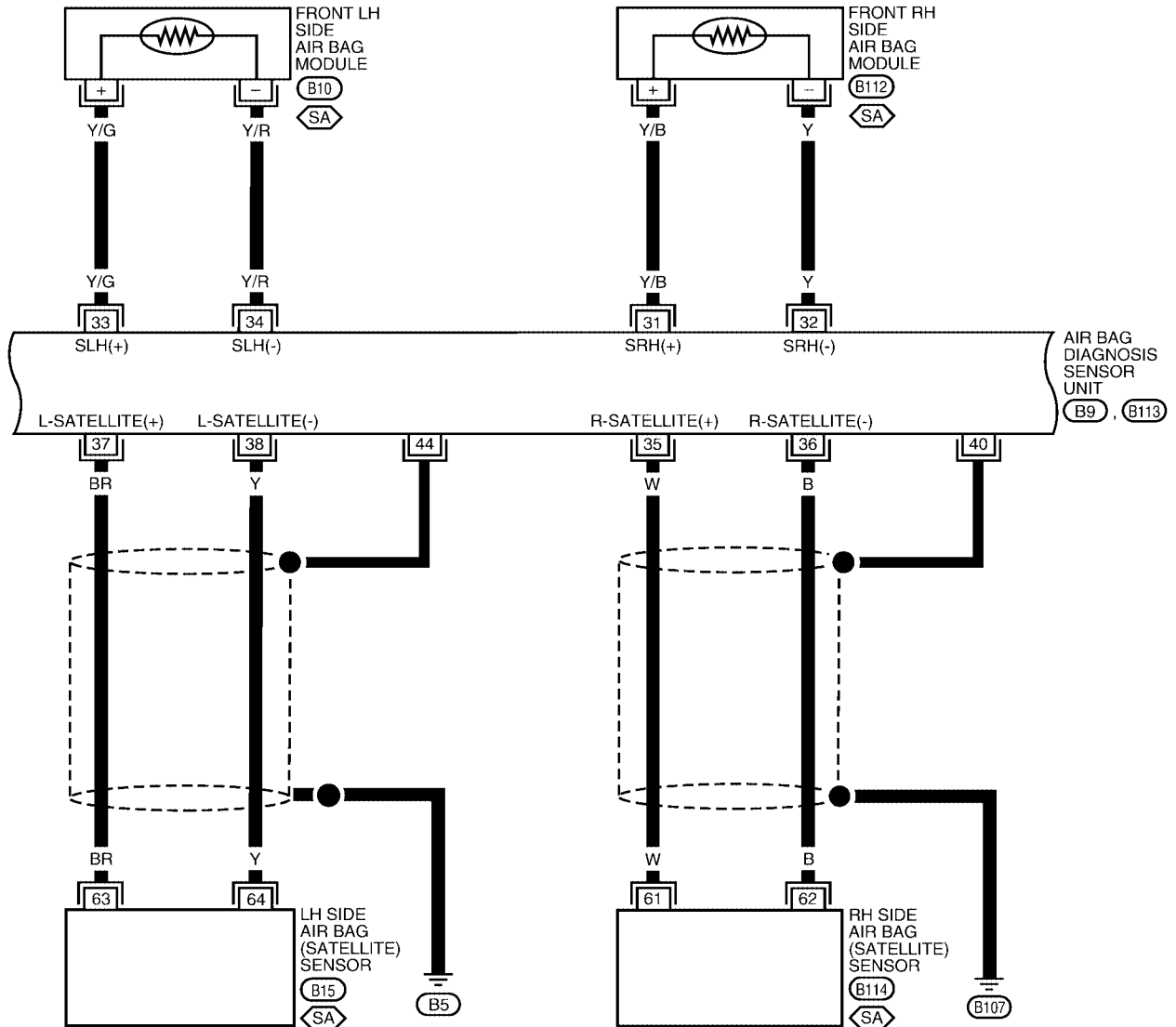

WHWA0020E

TROUBLE DIAGNOSIS

SRS-SRS-04

⬡SA⬡ : WITH SIDE AIR BAGS

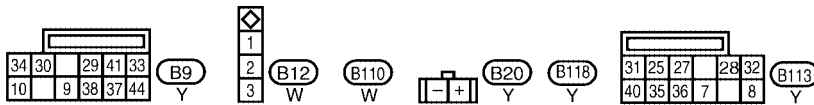
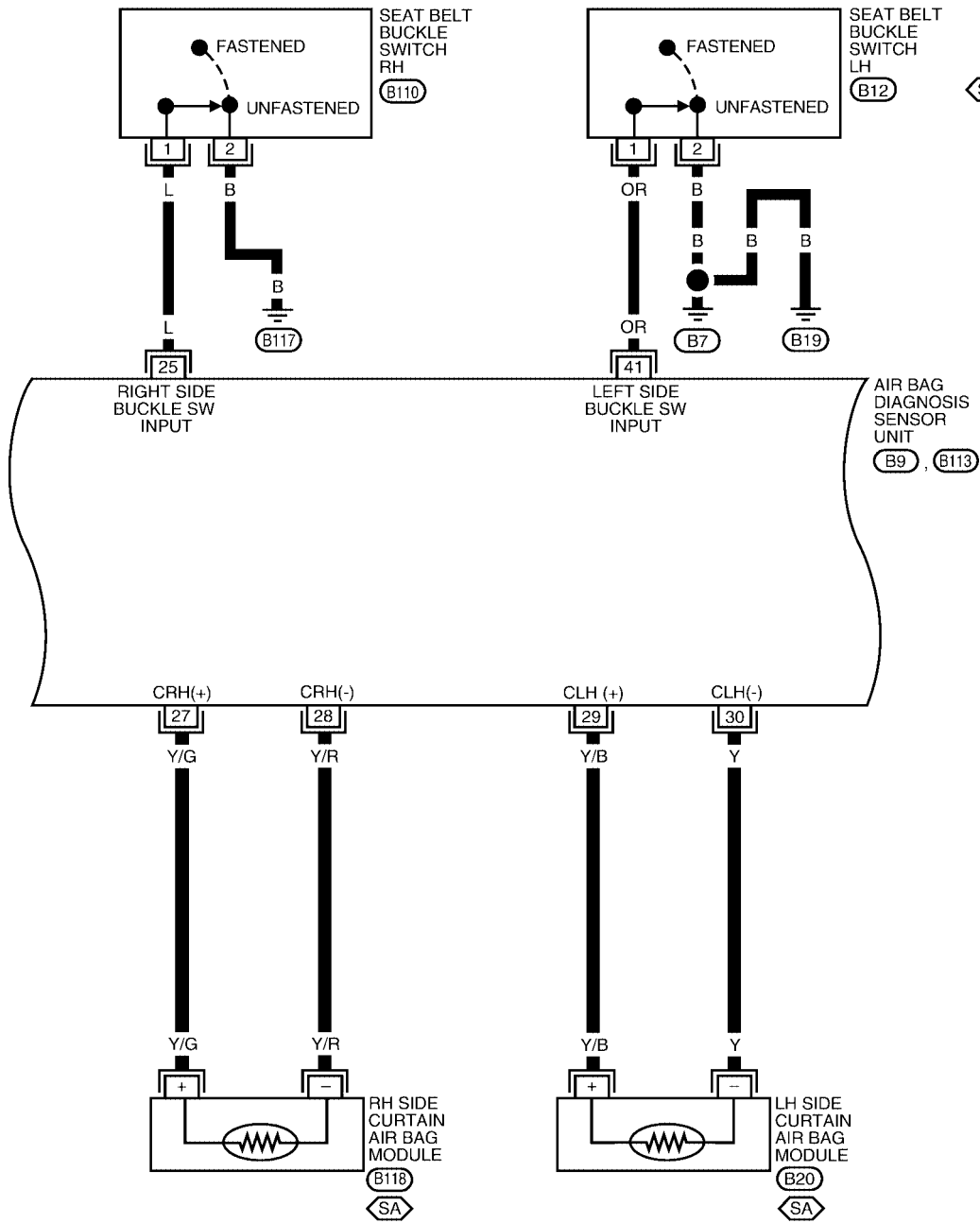

WHWA0021E

TROUBLE DIAGNOSIS

SRS-SRS-05

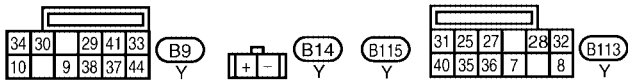
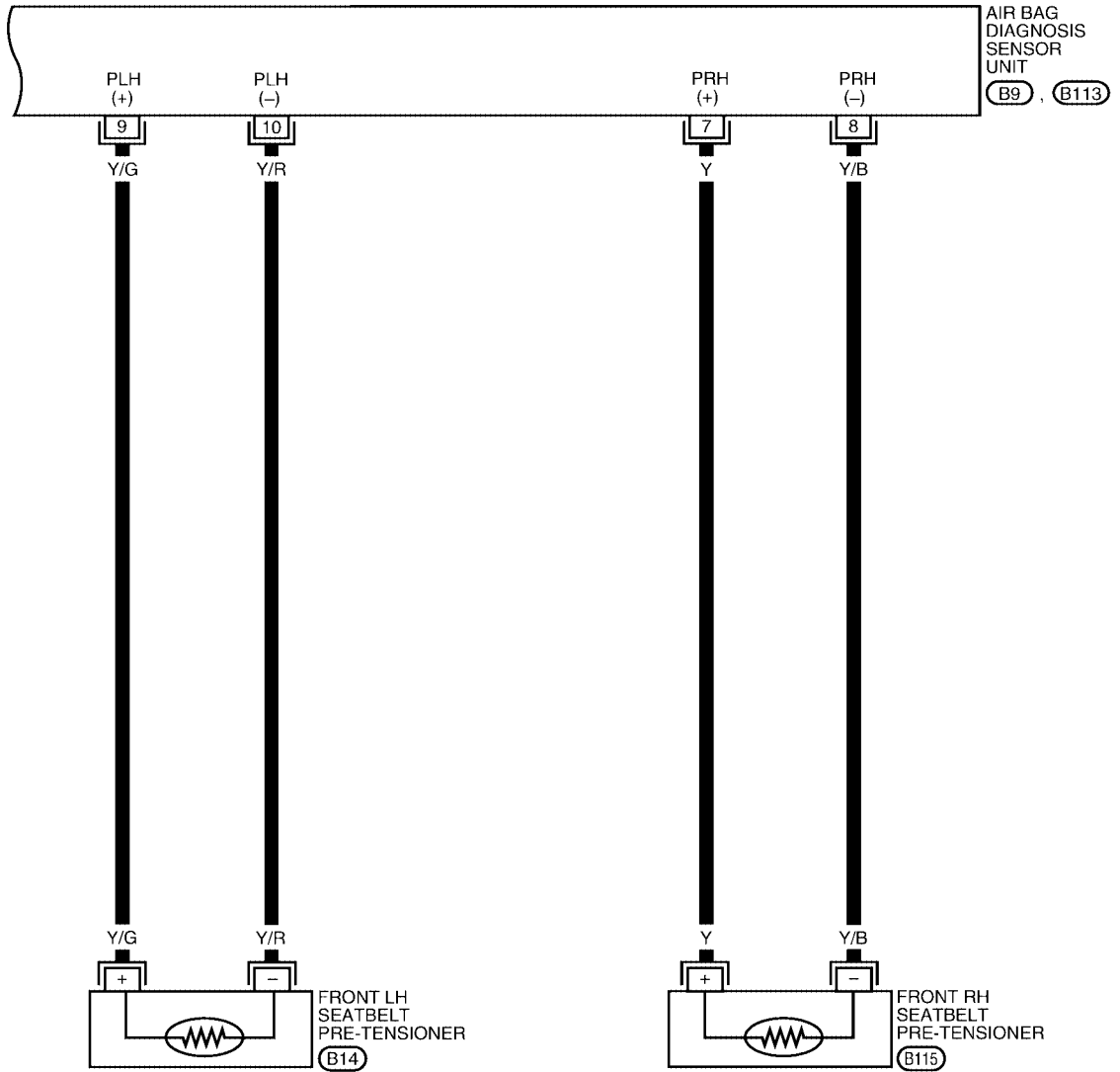

WHWA0022E

TROUBLE DIAGNOSIS

EHS000KS

CONSULT-II FUNCTION DIAGNOSIS MODE FOR CONSULT-II

- “SELF-DIAG [CURRENT]”
A current Self-diagnosis result (also indicated by the number of warning lamp flashes in the Diagnosis mode) is displayed on the CONSULT-II screen in real time. This refers to a malfunctioning part requiring repairs.
- “SELF-DIAG [PAST]”
Diagnosis results previously stored in the memory are displayed on the CONSULT-II screen. The stored results are not erased until memory erasing is executed.
- “TROUBLE DIAG RECORD”
With TROUBLE DIAG RECORD, diagnosis results previously erased by a reset operation can be displayed on the CONSULT-II screen.
- “ECU DISCRIMINATED NO.”
The diagnosis sensor unit for each vehicle model is assigned with its own, individual classification number. This number will be displayed on the CONSULT-II screen, as shown. When replacing the diagnosis sensor unit, refer to the part number for the compatibility. After installation, replacement with a correct unit can be checked by confirming this classification number on the CONSULT-II screen.

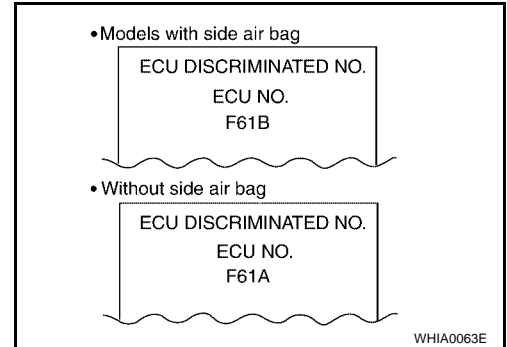

Ⓢ HOW TO CHANGE SELF-DIAGNOSIS MODE WITH CONSULT-II

From User Mode to Diagnosis Mode

After selecting “AIR BAG” on the “SELECT SYSTEM” screen, User mode automatically changes to Diagnosis mode.

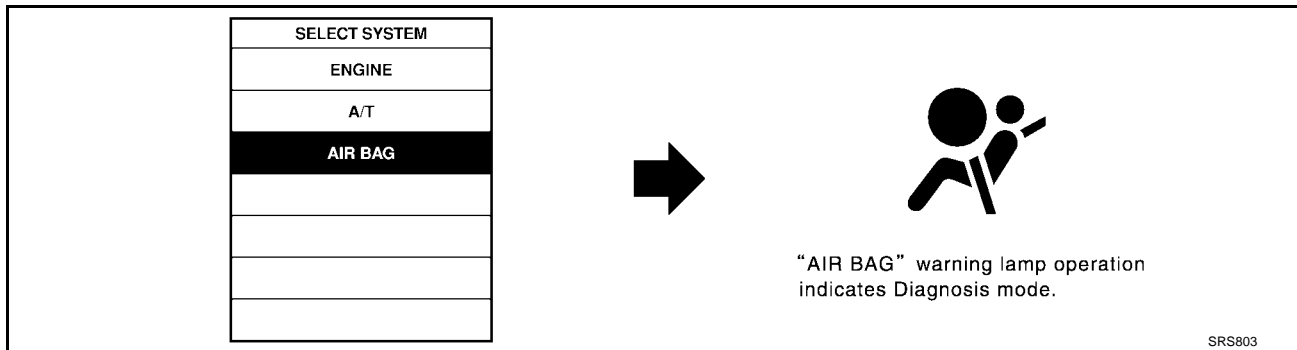

From Diagnosis Mode to User Mode

To return to User mode from Diagnosis mode, touch “BACK” key of CONSULT-II until “SELECT SYSTEM” appears, Diagnosis mode automatically changes to User mode.

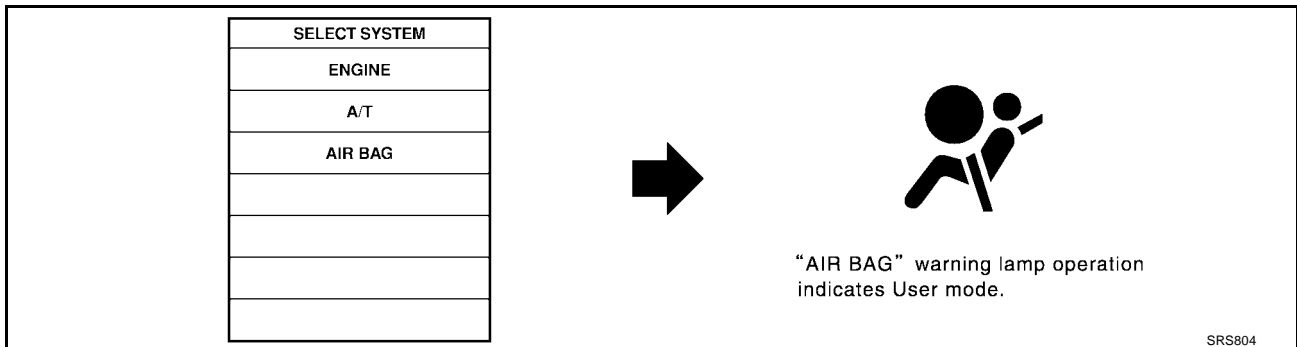

TROUBLE DIAGNOSIS

HOW TO ERASE SELF-DIAGNOSIS RESULTS

- “SELF-DIAG [CURRENT]”
A current Self-diagnosis result is displayed on the CONSULT-II screen in real time.
After the malfunction is repaired completely, no malfunction is detected on “SELF-DIAG [CURRENT]”.
- “SELF-DIAG [PAST]”
Return to the “SELF-DIAG [CURRENT]” CONSULT-II screen by touching “BACK” key of CONSULT-II and select “SELF-DIAG [CURRENT]” in SELECT DIAG MODE. Touch “ERASE” in “SELF-DIAG [CURRENT]” mode.

NOTE:

If the memory of the malfunction in “SELF-DIAG [PAST]” is not erased, the User mode shows the system malfunction by the operation of the warning lamp even if the malfunction is repaired completely.

- “TROUBLE DIAG RECORD”
The memory of “TROUBLE DIAG RECORD” cannot be erased.

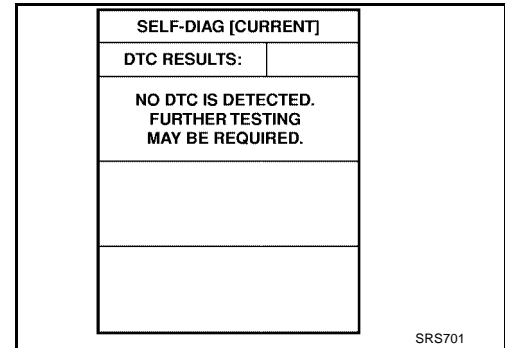

SELF-DIAGNOSIS FUNCTION (WITHOUT CONSULT-II)

EHS000KT

- The reading of these results is accomplished using one of two modes — “User mode” and “Diagnosis mode”.
- After a malfunction is repaired, turn the ignition switch OFF for at least one second, then back ON. Diagnosis mode returns to the User mode. At that time, the self-diagnostic result is cleared.

HOW TO CHANGE SELF-DIAGNOSIS MODE

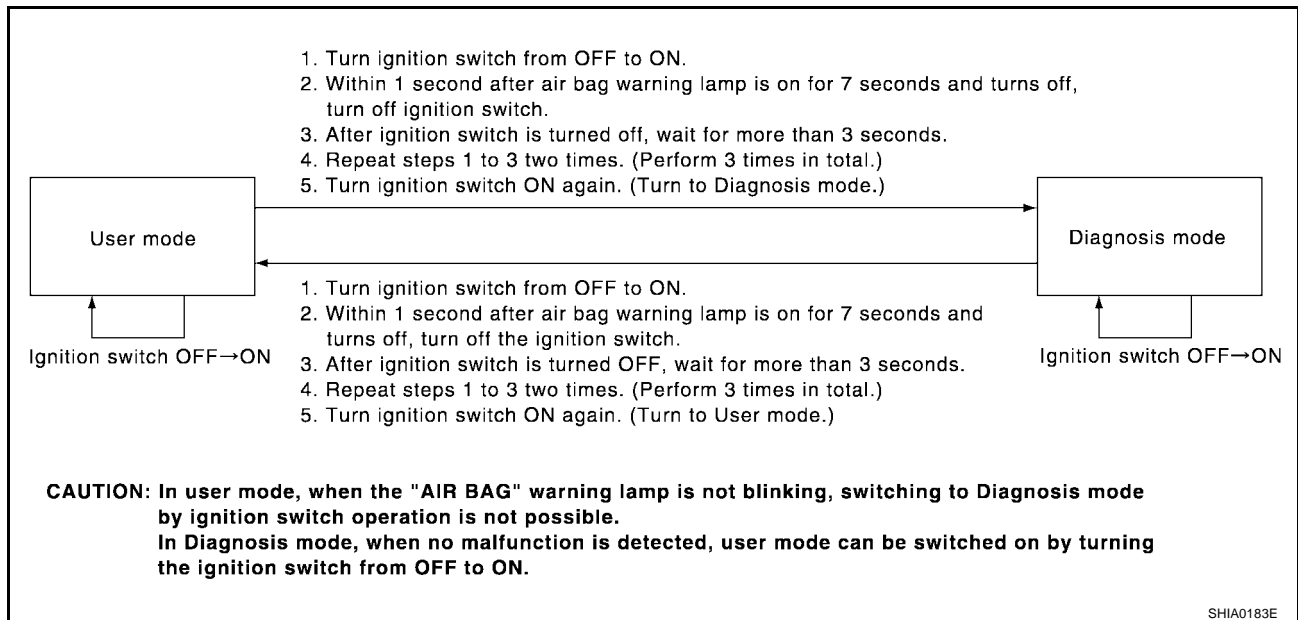

HOW TO ERASE SELF-DIAGNOSIS RESULTS

After a malfunction is repaired, turn the ignition switch OFF for at least one second, then back ON. Diagnosis mode returns to the User mode. At that time, the self-diagnostic result is cleared.

TROUBLE DIAGNOSIS

SRS Operation Check DIAGNOSTIC PROCEDURE 1

EHS000KU

Checking Air Bag Operation by Using "AIR BAG" Warning Lamp-User Mode

1. Turn the ignition switch from OFF to ON, and check that the air bag warning lamp blinks.
2. Compare the SRS air bag warning lamp blinking pattern with the examples.

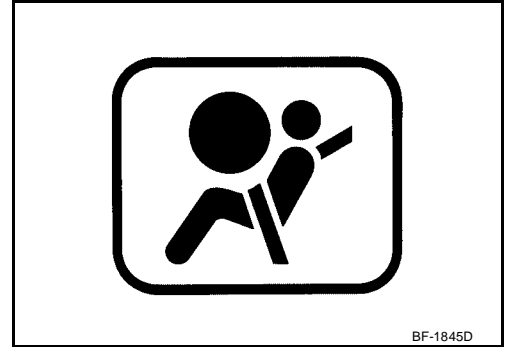



A
B
C
D
E
F
G
I
J
K
L
M

SRS

TROUBLE DIAGNOSIS

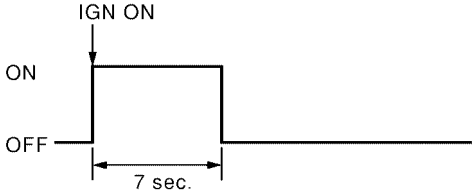
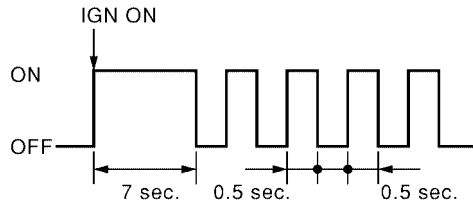
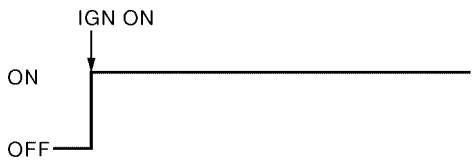
Warning lamp examples

"AIR BAG" warning lamp operation-User mode-	SRS condition	Reference item
 <p style="text-align: right;">SHIA0011E</p>	<ul style="list-style-type: none"> ● No malfunction is detected. ● No further action is necessary. 	—
 <p style="text-align: right;">SHIA0012E</p>	<ul style="list-style-type: none"> ● The system is malfunctioning and need to be repaired as indicated. 	Go to SRS-21, "DIAGNOSTIC PROCEDURE 2" or SRS-32, "DIAGNOSTIC PROCEDURE 6" .
 <p style="text-align: right;">SHIA0013E</p>	<ul style="list-style-type: none"> ● Air bag is deployed. ● Seat belt pre-tensioner is deployed. 	Go to SRS-61, "COLLISION DIAGNOSIS" .
 <p style="text-align: right;">SHIA0014E</p>	<ul style="list-style-type: none"> ● Diagnosis sensor unit is malfunctioning. ● Air bag power supply circuit is malfunctioning. ● SRS air bag warning lamp circuit is malfunctioning. 	Go to SRS-37, "Trouble Diagnoses: "AIR BAG" Warning Lamp Does Not Turn Off" .

TROUBLE DIAGNOSIS

Trouble Diagnoses with CONSULT-II DIAGNOSTIC PROCEDURE 2

EHS000KV

1. Turn ignition switch OFF.
2. Connect CONSULT-II to the data link connector.

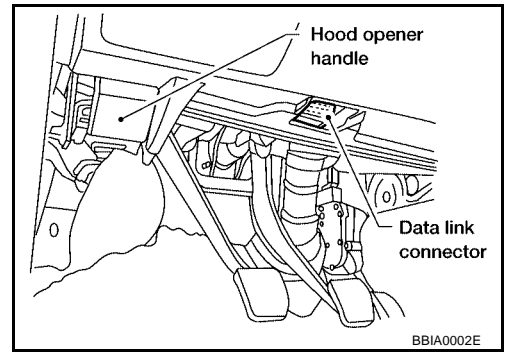

3. Turn ignition switch ON.
4. Touch "START".

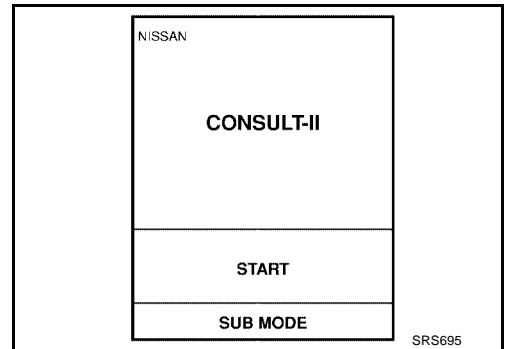

5. Touch "AIR BAG".

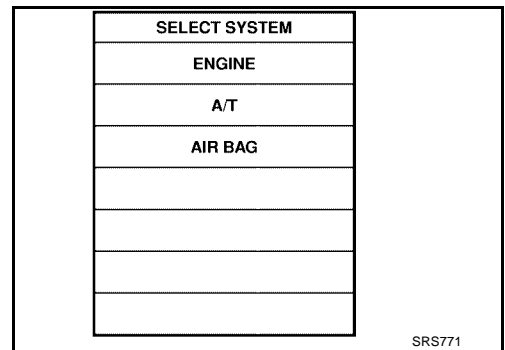

6. Touch "SELF-DIAG [CURRENT]".

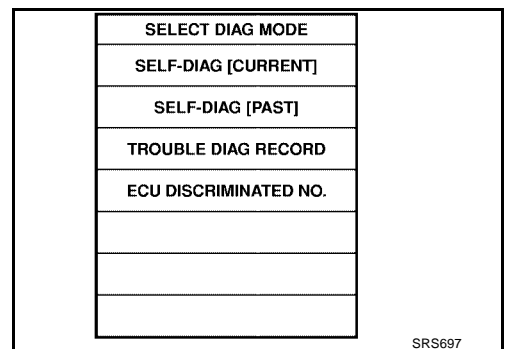

A
B
C
D
E
F
G
I
J
K
L
M

SRS

TROUBLE DIAGNOSIS

7. Diagnostic code is displayed on "SELF-DIAG [CURRENT]".

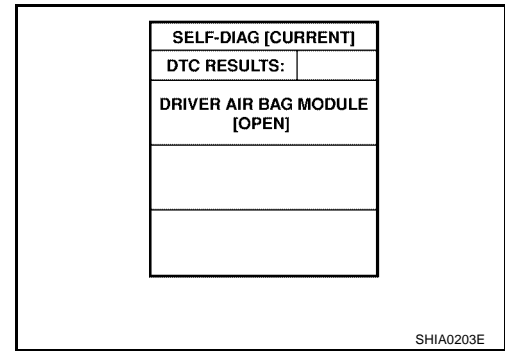

If no malfunction is detected on "SELF-DIAG [CURRENT]" even though malfunction is detected in "SRS Operation Check", refer to [SRS-27, "DIAGNOSTIC PROCEDURE 4 \(CONTINUED FROM DIAGNOSTIC PROCEDURE 2\)"](#), to diagnose the following cases:

- Self-diagnostic result "SELF-DIAG [PAST]" (previously stored in the memory) might not be erased after repair.
- The SRS system malfunctions intermittently.

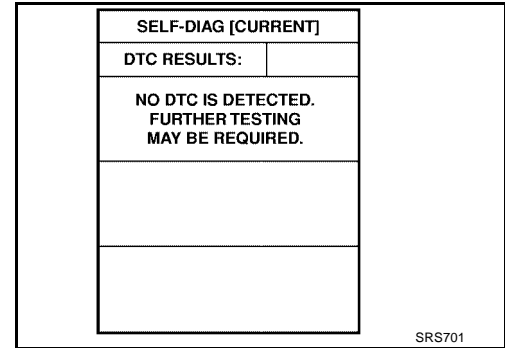

CONSULT-II Diagnostic Code Chart ("SELF-DIAG [CURRENT]")

Diagnostic item	Explanation	Repair order Recheck SRS at each replacement
NO DTC IS DETECTED.	When malfunction is indicated by the "AIR BAG" warning lamp in User mode. <ul style="list-style-type: none"> ● Low battery voltage (Less than 9V) ● Self-diagnostic result "SELF-DIAG [PAST]" (previously stored in the memory) might not be erased after repair. ● Intermittent malfunction has been detected in the past. 	<ul style="list-style-type: none"> ● Go to SRS-25, "DIAGNOSTIC PROCEDURE 3". ● Go to SRS-27, "DIAGNOSTIC PROCEDURE 4 (CONTINUED FROM DIAGNOSTIC PROCEDURE 2)". ● Go to SRS-27, "DIAGNOSTIC PROCEDURE 5".
	<ul style="list-style-type: none"> ● No malfunction is detected. 	—
DRIVER AIRBAG MODULE [OPEN]	<ul style="list-style-type: none"> ● Driver air bag module circuit is open (including the spiral cable). 	<ol style="list-style-type: none"> 1. Visually check the wiring harness connection. 2. Replace the harness if it has visible damage. 3. Replace driver air bag module. (Before disposal, it must be deployed.) 4. Replace the spiral cable. 5. Replace the diagnosis sensor unit. 6. Replace the related harness.
DRIVER AIRBAG MODULE [VB-SHORT]	<ul style="list-style-type: none"> ● Driver air bag module circuit is shorted to some power supply circuit (including the spiral cable). 	
DRIVER AIRBAG MODULE [GND-SHORT]	<ul style="list-style-type: none"> ● Driver air bag module circuit is shorted to ground (including the spiral cable). 	
DRIVER AIRBAG MODULE [SHORT]	<ul style="list-style-type: none"> ● Driver air bag module circuits are shorted to each other. 	
ASSIST A/B MODULE [VB-SHORT]	<ul style="list-style-type: none"> ● Front passenger air bag module circuit is shorted to some power supply circuit. 	<ol style="list-style-type: none"> 1. Visually check the wiring harness connection. 2. Replace the harness if it has visible damage. 3. Replace front passenger air bag module. (Before disposal, it must be deployed.) 4. Replace the diagnosis sensor unit. 5. Replace the related harness.
ASSIST A/B MODULE [OPEN]	<ul style="list-style-type: none"> ● Front passenger air bag module circuit is open. 	
ASSIST A/B MODULE [GND-SHORT]	<ul style="list-style-type: none"> ● Front passenger air bag module circuit is shorted to ground. 	
ASSIST A/B MODULE [SHORT]	<ul style="list-style-type: none"> ● Front passenger air bag module circuits are shorted to each other. 	

TROUBLE DIAGNOSIS

Diagnostic item	Explanation	Repair order Recheck SRS at each replacement	
CRASH ZONE SEN [UNIT FAIL] CRASH ZONE SEN [COMM FAIL] CRASH ZONE SEN [UNMATCH]	● Crash zone sensor	1. Visually check the wiring harness connection. 2. Replace the harness if it has visible damage. 3. Replace the crash zone sensor. 4. Replace the diagnosis sensor unit. 5. Replace the related harness.	A
SIDE MODULE LH [OPEN]	● Front LH side air bag module circuit is open.	1. Visually check the wiring harness connection.	D
SIDE MODULE LH [VB-SHORT]	● Front LH side air bag module circuit is shorted to some power supply circuit.	2. Replace the harness if it has visible damage.	B
SIDE MODULE LH [GND-SHORT]	● Front LH side air bag module circuit is shorted to ground.	3. Replace front LH seatback assembly (front LH side air bag module). (Before disposal, it must be deployed.)	C
SIDE MODULE LH [SHORT]	● Front LH side air bag module circuits are shorted to each other.	4. Replace the diagnosis sensor unit. 5. Replace the related harness.	E
SIDE MODULE RH [OPEN]	● Front RH side air bag module circuit is open.	1. Visually check the wiring harness connection.	F
SIDE MODULE RH [VB-SHORT]	● Front RH side air bag module circuit is shorted to some power supply circuit.	2. Replace the harness if it has visible damage.	G
SIDE MODULE RH [GND-SHORT]	● Front RH side air bag module circuit is shorted to ground.	3. Replace front RH seatback assembly (front RH side air bag module). (Before disposal, it must be deployed.)	I
SIDE MODULE RH [SHORT]	● Front RH side air bag module circuits are shorted to each other.	4. Replace the diagnosis sensor unit. 5. Replace the related harness.	J
SATELLITE SENS LH [UNIT FAIL] SATELLITE SENS LH [COMM FAIL] SATELLITE SENS LH [UNMATCH]	● LH side air bag (Satellite) sensor	1. Visually check the wiring harness connection. 2. Replace the harness if it has visible damage. 3. Replace the LH side air bag (satellite) sensor. 4. Replace the diagnosis sensor unit. 5. Replace the related harness.	K
SATELLITE SENS RH [UNIT FAIL] SATELLITE SENS RH [COMM FAIL] SATELLITE SENS RH [UNMATCH]	● RH side air bag (Satellite) sensor	1. Visually check the wiring harness connection. 2. Replace the harness if it has visible damage. 3. Replace the RH side air bag (satellite) sensor. 4. Replace the diagnosis sensor unit. 5. Replace the related harness.	L
			M

SRS

TROUBLE DIAGNOSIS

Diagnostic item	Explanation	Repair order Recheck SRS at each replacement
PRE-TEN FRONT LH [OPEN]	<ul style="list-style-type: none"> The circuit for front LH pre-tensioner is open. 	<ol style="list-style-type: none"> 1. Visually check the wiring harness connections. 2. Replace the harness if it has visible damage. 3. Replace front LH seat belt pre-tensioner. (Before disposal, it must be deployed.) 4. Replace the diagnosis sensor unit. 5. Replace the related harness.
PRE-TEN FRONT LH [VB-SHORT]	<ul style="list-style-type: none"> The circuit for front LH pre-tensioner is shorted to some power supply circuit. 	
PRE-TEN FRONT LH [GND-SHORT]	<ul style="list-style-type: none"> The circuit for front LH pre-tensioner is shorted to ground. 	
PRE-TEN FRONT LH [SHORT]	The circuits for the front LH pre-tensioner are shorted to each other.	
PRE-TEN FRONT RH [OPEN]	<ul style="list-style-type: none"> The circuit for front RH pre-tensioner is shorted to some power supply circuit. 	<ol style="list-style-type: none"> 1. Visually check the wiring harness connections. 2. Replace the harness if it has visible damage. 3. Replace front RH seat belt pre-tensioner. (Before disposal, it must be deployed.) 4. Replace the diagnosis sensor unit. 5. Replace the related harness.
PRE-TEN FRONT RH [VB-SHORT]	<ul style="list-style-type: none"> The circuit for front RH pre-tensioner is shorted to some power supply circuit. 	
PRE-TEN FRONT RH [GND-SHORT]	<ul style="list-style-type: none"> The circuit for front RH pre-tensioner is shorted to ground. 	
PRE-TEN FRONT RH [SHORT]	The circuits for the front RH pre-tensioner are shorted to each other.	
CURTAIN MODULE LH [OPEN]	<ul style="list-style-type: none"> The LH side curtain air bag module circuit is open. 	<ol style="list-style-type: none"> 1. Visually check the wiring harness connection. 2. Replace the harness if it has visible damage. 3. Replace LH side curtain air bag module. (Before disposal, it must be deployed.) 4. Replace the diagnosis sensor unit. 5. Replace the related harness.
CURTAIN MODULE LH [VB-SHORT]	<ul style="list-style-type: none"> The LH side curtain air bag module circuit is shorted to some power supply circuits. 	
CURTAIN MODULE LH [GND-SHORT]	<ul style="list-style-type: none"> The LH side curtain air bag module circuit is shorted to ground. 	
CURTAIN MODULE RH [OPEN]	<ul style="list-style-type: none"> The RH side curtain air bag module circuit is open. 	<ol style="list-style-type: none"> 1. Visually check the wiring harness connection. 2. Replace the harness if it has visible damage. 3. Replace RH side curtain air bag module. (Before disposal, it must be deployed.) 4. Replace the diagnosis sensor unit. 5. Replace the related harness.
CURTAIN MODULE RH [VB-SHORT]	<ul style="list-style-type: none"> The RH side curtain air bag module circuit is shorted to some power supply circuit. 	
CURTAIN MODULE RH [GND-SHORT]	<ul style="list-style-type: none"> The RH side curtain air bag module circuit is shorted to ground. 	
CONTROL UNIT	<ul style="list-style-type: none"> Diagnosis sensor unit is malfunctioning. 	<ol style="list-style-type: none"> 1. Visually check the wiring harness connection. 2. Replace the diagnosis sensor unit.

NOTE:

- Follow the procedures in numerical order when repairing malfunctioning parts. Confirm whether malfunction is eliminated using air bag warning lamp or CONSULT-II each time repair is finished. If malfunction is still observed, proceed to the next step. When malfunction is eliminated, further repair work is not required.

TROUBLE DIAGNOSIS

DIAGNOSTIC PROCEDURE 3

Final checking after repairing SRS by using CONSULT-II — Diagnosis mode

1. After repairing SRS, connect both battery cables.
2. Connect CONSULT-II to data link connector.
3. Turn ignition switch "ON".

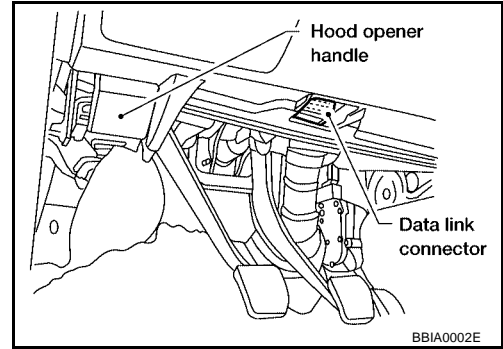

4. Touch "START".

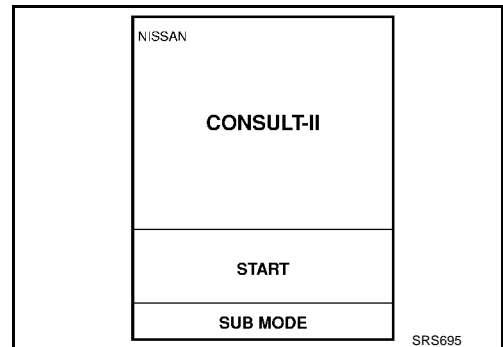

5. Touch "AIR BAG".

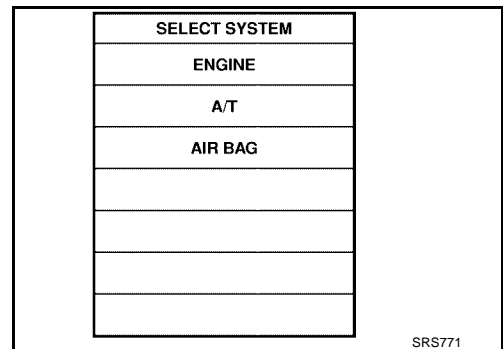

6. Touch "SELF-DIAG [CURRENT]".

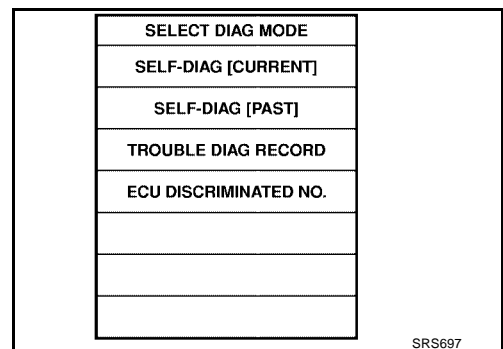

A
B
C
D
E
F
G
I
J
K
L
M

SRS

TROUBLE DIAGNOSIS

7. If no malfunction is detected on "SELF-DIAG [CURRENT]", repair of SRS is completed. Go to step 8.
 If any malfunction is detected on "SELF-DIAG [CURRENT]", the malfunctioning part is not repaired completely or another malfunctioning part is detected. Go to [SRS-21, "DIAGNOSTIC PROCEDURE 2"](#), and repair malfunctioning part completely.

SELF-DIAG [CURRENT]	
DTC RESULTS:	
NO DTC IS DETECTED. FURTHER TESTING MAY BE REQUIRED.	

SRS701

8. Touch "ERASE".

NOTE:

Touch "ERASE" to clear the memory of the malfunction ("SELF-DIAG [PAST])."

If the memory of the malfunction in "SELF-DIAG [PAST]" is not erased, the User mode shows the system malfunction by the operation of the warning lamp even if the malfunction is repaired completely.

SELF-DIAG [CURRENT]	
DTC RESULTS:	
AIR BAG MODULE [OPEN]	
ERASE	

SRS773

9. Touch "BACK" key of CONSULT-II to "SELECT DIAG MODE" screen. Touch "SELF-DIAG [PAST]".

SELECT DIAG MODE
SELF-DIAG [CURRENT]
SELF-DIAG [PAST]
TROUBLE DIAG RECORD
ECU DISCRIMINATED NO.

SRS697

10. Check that no malfunction is detected on "SELF-DIAG [PAST]".
 11. Touch "BACK" key of CONSULT-II until "SELECT SYSTEM" appears in order to return to User mode from Diagnosis mode.
 12. Turn ignition switch OFF then turn off and disconnect CONSULT-II.
 13. Go to [SRS-19, "Checking Air Bag Operation by Using "AIR BAG" Warning Lamp-User Mode"](#).

SELF-DIAG [PAST]	
DTC RESULTS:	
NO DTC IS DETECTED. FURTHER TESTING MAY BE REQUIRED.	

SRS702

TROUBLE DIAGNOSIS

DIAGNOSTIC PROCEDURE 4 (CONTINUED FROM DIAGNOSTIC PROCEDURE 2)

Inspecting SRS malfunctioning record

1. CONSIDER POSSIBILITY OF NOT ERASING SELF-DIAGNOSTIC RESULT AFTER REPAIRING

Is it the first time for maintenance of SRS?

Yes or No

Yes >> Go to [SRS-21, "DIAGNOSTIC PROCEDURE 2"](#).

No >> Self-diagnostic result "SELF-DIAG [PAST]" (previously stored in the memory) might not be erased after repair. Go to [SRS-25, "DIAGNOSTIC PROCEDURE 3"](#).

DIAGNOSTIC PROCEDURE 5

Inspecting SRS intermittent malfunction by using CONSULT-II — Diagnosis mode

1. Turn ignition switch OFF.
2. Connect "CONSULT-II" to data link connector.

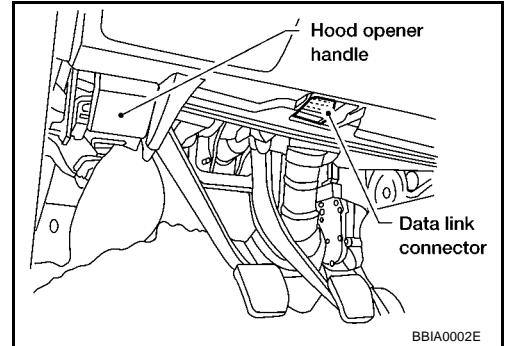

3. Turn ignition switch ON.
4. Touch "START".

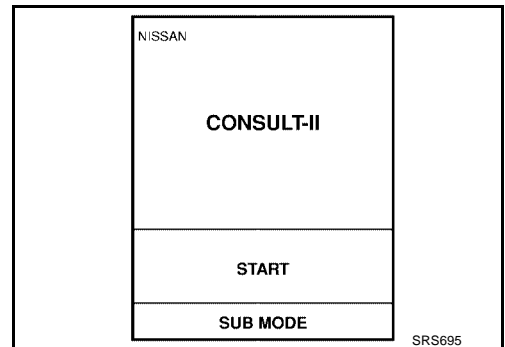

5. Touch "AIR BAG".

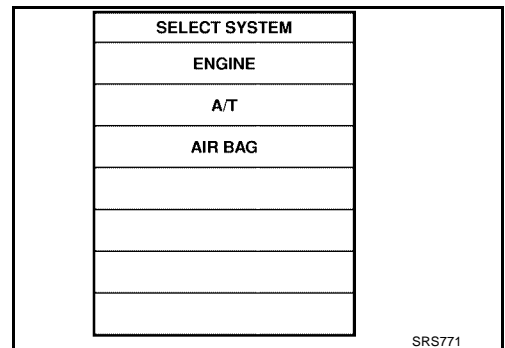

TROUBLE DIAGNOSIS

6. Touch "SELF-DIAG [PAST]".

SELECT DIAG MODE
SELF-DIAG [CURRENT]
SELF-DIAG [PAST]
TROUBLE DIAG RECORD
ECU DISCRIMINATED NO.

SRS697

7. If diagnostic codes are displayed on "SELF-DIAG [PAST]", go to step 10.

SELF-DIAG [PAST]	
DTC RESULTS:	
AIR BAG MODULE [OPEN]	

SRS700

If no malfunction is detected on "SELF-DIAG [PAST]", touch "BACK" and go back to "SELECT DIAG MODE".

SELF-DIAG [PAST]	
DTC RESULTS:	
NO DTC IS DETECTED. FURTHER TESTING MAY BE REQUIRED.	

SRS702

8. Touch "TROUBLE DIAG RECORD".

NOTE:
With "TROUBLE DIAG RECORD", diagnosis results previously erased by a reset operation can be displayed.

SELECT DIAG MODE
SELF-DIAG [CURRENT]
SELF-DIAG [PAST]
TROUBLE DIAG RECORD
ECU DISCRIMINATED NO.

SRS697

- 9. Diagnostic code is displayed on "TROUBLE DIAG RECORD".
- 10. Touch "PRINT".
- 11. Compare diagnostic codes to [SRS-29, "CONSULT-II Diagnostic Code Chart \("SELF-DIAG \[PAST\]" or "TROUBLE DIAG RECORD"\)"](#) .
- 12. Touch "BACK" key of CONSULT-II until "SELECT SYSTEM" appears.
- 13. Turn ignition switch OFF, then turn off and disconnect CONSULT-II, and both battery cables.

TROUBLE DIAG RECORD	
DTC RESULTS:	
DRIVER AIR BAG MODULE [OPEN]	

SHIA0182E

TROUBLE DIAGNOSIS

14. Repair the system as outlined by the "Repair order" in "Intermittent Malfunction Diagnostic Code Chart", that corresponds to the self-diagnostic result. For replacement procedure of component parts, refer to the Removal and Installation procedure for the appropriate component.

15. Go to [SRS-25, "DIAGNOSTIC PROCEDURE 3"](#), for final checking.

CONSULT-II Diagnostic Code Chart ("SELF-DIAG [PAST]" or "TROUBLE DIAG RECORD")

Diagnostic item	Explanation	Repair order Recheck SRS at each replacement
NO DTC IS DETECTED.	When malfunction is indicated by the "AIR BAG" warning lamp in User mode.	<ul style="list-style-type: none"> ● Low battery voltage (Less than 9V) ● Go to SRS-25, "DIAGNOSTIC PROCEDURE 3".
	<ul style="list-style-type: none"> ● Self-diagnostic result "SELF-DIAG [PAST]" (previously stored in the memory) might not be erased after repair. ● Intermittent malfunction has been detected in the past. 	<ul style="list-style-type: none"> ● Go to SRS-27, "DIAGNOSTIC PROCEDURE 4 (CONTINUED FROM DIAGNOSTIC PROCEDURE 2)". ● Go to SRS-27, "DIAGNOSTIC PROCEDURE 5".
	<ul style="list-style-type: none"> ● No malfunction is detected. 	—
DRIVER AIRBAG MODULE [OPEN]	<ul style="list-style-type: none"> ● Driver air bag module circuit is open (including the spiral cable). 	<ol style="list-style-type: none"> 1. Visually check the wiring harness connection. 2. Replace the harness if it has visible damage.
DRIVER AIRBAG MODULE [VB-SHORT]	<ul style="list-style-type: none"> ● Driver air bag module circuit is shorted to some power supply circuit (including the spiral cable). 	<ol style="list-style-type: none"> 3. Replace driver air bag module. (Before disposal, it must be deployed.)
DRIVER AIRBAG MODULE [GND-SHORT]	<ul style="list-style-type: none"> ● Driver air bag module circuit is shorted to ground (including the spiral cable). 	<ol style="list-style-type: none"> 4. Replace the spiral cable. 5. Replace the diagnosis sensor unit.
DRIVER AIRBAG MODULE [SHORT]	<ul style="list-style-type: none"> ● Driver air bag module circuits are shorted to each other. 	<ol style="list-style-type: none"> 6. Replace the related harness.
ASSIST A/B MODULE [VB-SHORT]	<ul style="list-style-type: none"> ● Front passenger air bag module circuit is shorted to some power supply circuit. 	<ol style="list-style-type: none"> 1. Visually check the wiring harness connection.
ASSIST A/B MODULE [OPEN]	<ul style="list-style-type: none"> ● Front passenger air bag module circuit is open. 	<ol style="list-style-type: none"> 2. Replace the harness if it has visible damage.
ASSIST A/B MODULE [GND-SHORT]	<ul style="list-style-type: none"> ● Front passenger air bag module circuit is shorted to ground. 	<ol style="list-style-type: none"> 3. Replace front passenger air bag module. (Before disposal, it must be deployed.)
ASSIST A/B MODULE [SHORT]	<ul style="list-style-type: none"> ● Front passenger air bag module circuits are shorted to each other. 	<ol style="list-style-type: none"> 4. Replace the diagnosis sensor unit. 5. Replace the related harness.
CRASH ZONE SEN [UNIT FAIL] CRASH ZONE SEN [COMM FAIL] CRASH ZONE SEN [UNMATCH]	<ul style="list-style-type: none"> ● Crash zone sensor 	<ol style="list-style-type: none"> 1. Visually check the wiring harness connection. 2. Replace the harness if it has visible damage. 3. Replace the crash zone sensor. 4. Replace the diagnosis sensor unit. 5. Replace the related harness.
SIDE MODULE LH [OPEN]	<ul style="list-style-type: none"> ● Front LH side air bag module circuit is open. 	<ol style="list-style-type: none"> 1. Visually check the wiring harness connection.
SIDE MODULE LH [VB-SHORT]	<ul style="list-style-type: none"> ● Front LH side air bag module circuit is shorted to some power supply circuit. 	<ol style="list-style-type: none"> 2. Replace the harness if it has visible damage.
SIDE MODULE LH [GND-SHORT]	<ul style="list-style-type: none"> ● Front LH side air bag module circuit is shorted to ground. 	<ol style="list-style-type: none"> 3. Replace front LH seatback assembly (front LH side air bag module). (Before disposal, it must be deployed.)
SIDE MODULE LH [SHORT]	<ul style="list-style-type: none"> ● Front LH side air bag module circuits are shorted to each other. 	<ol style="list-style-type: none"> 4. Replace the diagnosis sensor unit. 5. Replace the related harness.

TROUBLE DIAGNOSIS

Diagnostic item	Explanation	Repair order Recheck SRS at each replacement
SIDE MODULE RH [OPEN]	<ul style="list-style-type: none"> ● Front RH side air bag module circuit is open. 	<ol style="list-style-type: none"> 1. Visually check the wiring harness connection. 2. Replace the harness if it has visible damage. 3. Replace front RH seatback assembly (front RH side air bag module). (Before disposal, it must be deployed.) 4. Replace the diagnosis sensor unit. 5. Replace the related harness.
SIDE MODULE RH [VB-SHORT]	<ul style="list-style-type: none"> ● Front RH side air bag module circuit is shorted to some power supply circuit. 	
SIDE MODULE RH [GND-SHORT]	<ul style="list-style-type: none"> ● Front RH side air bag module circuit is shorted to ground. 	
SIDE MODULE RH [SHORT]	<ul style="list-style-type: none"> ● Front RH side air bag module circuits are shorted to each other. 	
SATELLITE SENS LH [UNIT FAIL] SATELLITE SENS LH [COMM FAIL] SATELLITE SENS LH [UNMATCH]	<ul style="list-style-type: none"> ● LH side air bag (Satellite) sensor 	<ol style="list-style-type: none"> 1. Visually check the wiring harness connection. 2. Replace the harness if it has visible damage. 3. Replace the LH side air bag (satellite) sensor. 4. Replace the diagnosis sensor unit. 5. Replace the related harness.
SATELLITE SENS RH [UNIT FAIL] SATELLITE SENS RH [COMM FAIL] SATELLITE SENS RH [UNMATCH]	<ul style="list-style-type: none"> ● RH side air bag (Satellite) sensor 	<ol style="list-style-type: none"> 1. Visually check the wiring harness connection. 2. Replace the harness if it has visible damage. 3. Replace the RH side air bag (satellite) sensor. 4. Replace the diagnosis sensor unit. 5. Replace the related harness.
PRE-TEN FRONT LH [OPEN]	<ul style="list-style-type: none"> ● The circuit for front LH pre-tensioner is open. 	<ol style="list-style-type: none"> 1. Visually check the wiring harness connections. 2. Replace the harness if it has visible damage. 3. Replace front LH seat belt pre-tensioner. (Before disposal, it must be deployed.) 4. Replace the diagnosis sensor unit. 5. Replace the related harness.
PRE-TEN FRONT LH [VB-SHORT]	<ul style="list-style-type: none"> ● The circuit for front LH pre-tensioner is shorted to some power supply circuit. 	
PRE-TEN FRONT LH [GND-SHORT]	<ul style="list-style-type: none"> ● The circuit for front LH pre-tensioner is shorted to ground. 	
PRE-TEN FRONT RH [OPEN]	<ul style="list-style-type: none"> ● The circuit for front RH pre-tensioner is shorted to some power supply circuit. 	<ol style="list-style-type: none"> 1. Visually check the wiring harness connections. 2. Replace the harness if it has visible damage. 3. Replace front RH seat belt pre-tensioner. (Before disposal, it must be deployed.) 4. Replace the diagnosis sensor unit. 5. Replace the related harness.
PRE-TEN FRONT RH [VB-SHORT]	<ul style="list-style-type: none"> ● The circuit for front RH pre-tensioner is shorted to some power supply circuit. 	
PRE-TEN FRONT RH [GND-SHORT]	<ul style="list-style-type: none"> ● The circuit for front RH pre-tensioner is shorted to ground. 	

TROUBLE DIAGNOSIS

Diagnostic item	Explanation	Repair order Recheck SRS at each replacement	
CURTAIN MODULE LH [OPEN]	<ul style="list-style-type: none"> The LH side curtain air bag module circuit is open. 	1. Visually check the wiring harness connection.	A
CURTAIN MODULE LH [VB-SHORT]	<ul style="list-style-type: none"> The LH side curtain air bag module circuit is shorted to some power supply circuits. 	2. Replace the harness if it has visible damage.	B
CURTAIN MODULE LH [GND-SHORT]	<ul style="list-style-type: none"> The LH side curtain air bag module circuit is shorted to ground. 	3. Replace LH side curtain air bag module. (Before disposal, it must be deployed.)	C
		4. Replace the diagnosis sensor unit.	D
		5. Replace the related harness.	
CURTAIN MODULE RH [OPEN]	<ul style="list-style-type: none"> The RH side curtain air bag module circuit is open. 	1. Visually check the wiring harness connection.	
CURTAIN MODULE RH [VB-SHORT]	<ul style="list-style-type: none"> The RH side curtain air bag module circuit is shorted to some power supply circuit. 	2. Replace the harness if it has visible damage.	E
CURTAIN MODULE RH [GND-SHORT]	<ul style="list-style-type: none"> The RH side curtain air bag module circuit is shorted to ground. 	3. Replace RH side curtain air bag module. (Before disposal, it must be deployed.)	F
		4. Replace the diagnosis sensor unit.	G
		5. Replace the related harness.	
CONTROL UNIT	<ul style="list-style-type: none"> Diagnosis sensor unit is malfunctioning. 	1. Visually check the wiring harness connection.	
		2. Replace the diagnosis sensor unit.	SRS

I
J
K
L
M

TROUBLE DIAGNOSIS

Trouble diagnoses without CONSULT-II.

EHS000KW

DIAGNOSTIC PROCEDURE 6

Inspecting SRS malfunctioning parts by using "AIR BAG" warning lamp—Diagnosis mode

NOTE:

SRS will not enter Diagnosis mode if no malfunction is detected in User mode.

1. Turn ignition switch ON.
2. After "AIR BAG" warning lamp lights for 7 seconds, turn ignition switch OFF within 1 second.
3. Wait more than 3 seconds.
4. Repeat steps 1 to 3 two times.
5. Turn ignition switch ON.

SRS is now in Diagnosis mode.

"AIR BAG" warning lamp operates in Diagnosis mode as follows:

TROUBLE DIAGNOSIS

WARNING LAMP FLASH CODE CHART

<Diagnosis results (previously stored in the memory) might not be erased after repair or intermittent malfunctions have been detected in the past.>

Flash pattern	Repair order
<p>a through b are repeated.</p>	<p>1. Go to DIAGNOSTIC PROCEDURES 2 and 3.</p>

SHIA0026E

<Driver air bag module>	
Flash pattern	Repair order
<p>a through d are repeated. d: Two flashes indicate malfunctioning driver air bag module circuits.</p>	<ol style="list-style-type: none"> 1. Visually check the wiring harness connection. 2. Replace the harness if it has visible damage. 3. Replace the spiral cable. 4. Replace driver air bag module. (Before disposal, it must be deployed.) 5. Replace the diagnosis sensor unit. 6. Replace the related harness.

LHIA0023E

<Diagnosis sensor unit>	
Flash pattern	Repair order
<p>a through d are repeated. d: Seven flashes indicate malfunctioning diagnosis sensor unit circuit.</p>	<ol style="list-style-type: none"> 1. Visually check the wiring harness connections. 2. Replace the harness if it has visible damage. 3. Replace the diagnosis sensor unit. 4. Replace the related harness.

SHIA0028E

<Front passenger air bag module>	
Flash pattern	Repair order
<p>a through d are repeated. d: Eight flashes indicate malfunctioning front passenger air bag module circuit.</p>	<ol style="list-style-type: none"> 1. Visually check the wiring harness connection. 2. Replace the harness if it has visible damage. 3. Replace front passenger air bag module. (Before disposal, it must be deployed.) 4. Replace the diagnosis sensor unit. 5. Replace the related harness.

SHIA0029E

TROUBLE DIAGNOSIS

<Crash zone sensor>	
Flash pattern	Repair order
<p>a through d are repeated. d: Six flashes indicate malfunctioning crash zone sensor circuit.</p>	<ol style="list-style-type: none"> 1. Visually check the wiring harness connection. 2. Replace the harness if it has visible damage. 3. Replace the crash zone sensor. 4. Replace the diagnosis sensor unit. 5. Replace the related harness.

SHIA0083E

<Front RH seat belt pre-tensioner>	
Flash pattern	Repair order
<p>a through d are repeated. d: One flash indicates malfunctioning front RH seat belt pre-tensioner circuit.</p>	<ol style="list-style-type: none"> 1. Visually check the wiring harness connections. 2. Replace the harness if it has visible damage. 3. Replace front RH seat belt pre-tensioner. (Before disposal, it must be activated.) 4. Replace the diagnosis sensor unit. 5. Replace the related harness.

SHIA0030E

<Front LH seat belt pre-tensioner>	
Flash pattern	Repair order
<p>a through d are repeated. d: Three flashes indicate malfunctioning front LH seat belt pre-tensioner circuit.</p>	<ol style="list-style-type: none"> 1. Visually check the wiring harness connections. 2. Replace the harness if it has visible damage. 3. Replace front LH seat belt pre-tensioner. (Before disposal, it must be activated.) 4. Replace the diagnosis sensor unit. 5. Replace the related harness.

SHIA0031E

<RH side air bag (Satellite) sensor>	
Flash pattern	Repair order
<p>a through f are repeated. f: Three flashes indicate malfunctioning RH side air bag (Satellite) sensor circuit.</p>	<ol style="list-style-type: none"> 1. Visually check the wiring harness connection. 2. Replace the harness if it has visible damage. 3. Replace the RH side air bag (Satellite) sensor. 4. Replace the diagnosis sensor unit. 5. Replace the related harness.

SHIA0032E

TROUBLE DIAGNOSIS

<LH side air bag (Satellite) sensor>	
Flash pattern	Repair order
<p>a through f are repeated. f: Four flashes indicate malfunctioning LH side air bag (Satellite) sensor.</p>	<ol style="list-style-type: none"> 1. Visually check the wiring harness connection. 2. Replace the harness if it has visible damage. 3. Replace the LH side air bag (Satellite) sensor. 4. Replace the diagnosis sensor unit. 5. Replace the related harness.

SHIA0033E

<Front RH side air bag module>	
Flash pattern	Repair order
<p>a through f are repeated. f: One flash indicate malfunctioning front RH side air bag module circuit.</p>	<ol style="list-style-type: none"> 1. Visually check the wiring harness connection. 2. Replace the harness if it has visible damage. 3. Replace front RH seat back assembly. (Before disposal, side air bag module must be deployed.) 4. Replace the diagnosis sensor unit. 5. Replace the related harness.

WHIA0064E

<Front LH side air bag module>	
Flash pattern	Repair order
<p>a through f are repeated. f: Two flashes indicate malfunctioning front LH side air bag module circuit.</p>	<ol style="list-style-type: none"> 1. Visually check the wiring harness connection. 2. Replace the harness if it has visible damage. 3. Replace front LH seat back assembly. (Before disposal, side air bag module must be deployed.) 4. Replace the diagnosis sensor unit. 5. Replace the related harness.

WHIA0065E

<RH side curtain air bag module>	
Flash pattern	Repair order
<p>a through f are repeated. f: Five flashes indicate malfunctioning RH side curtain air bag module circuit.</p>	<ol style="list-style-type: none"> 1. Visually check the wiring harness connection. 2. Replace the harness if it has visible damage. 3. Replace RH side curtain air bag module. (Before disposal, it must be deployed.) 4. Replace the diagnosis sensor unit. 5. Replace the related harness.

SHIA0084E

TROUBLE DIAGNOSIS

<LH side curtain air bag module>

Flash pattern	Repair order
<p>a through f are repeated. f: Six flashes indicate malfunctioning LH side curtain air bag module circuit.</p>	<ol style="list-style-type: none"> 1. Visually check the wiring harness connection. 2. Replace the harness if it has visible damage. 3. Replace LH side curtain air bag module. (Before disposal, it must be deployed.) 4. Replace the diagnosis sensor unit. 5. Replace the related harness.

SHIA0086E

TROUBLE DIAGNOSIS

Trouble Diagnoses: "AIR BAG" Warning Lamp Does Not Turn Off DIAGNOSTIC PROCEDURE 6

EHS000KX

1. SEE THE DEPLOYMENT OF AIR BAG MODULE

Is air bag module deployed?

Yes or No

- Yes >> Refer to [SRS-61, "COLLISION DIAGNOSIS"](#).
- No >> GO TO 2.

2. CHECK THE AIR BAG FUSE

Check 10A fuse [No. 13, located in the fuse block (J/B)].
Refer to [PG-3, "POWER SUPPLY ROUTING CIRCUIT"](#).

OK or NG

- OK >> GO TO 4.
- NG >> GO TO 3.

3. CHECK AIR BAG FUSE AGAIN

Replace "AIR BAG" fuse and turn ignition switch ON.

Does the "AIR BAG" fuse blow again?

- Yes >> Repair main harness.
- No >> **INSPECTION END.**

4. CHECK DIAGNOSIS SENSOR UNIT



Connect CONSULT-II and touch "START".

- Is "AIR BAG" displayed on CONSULT-II?

Yes or No

- Yes >> GO TO 5.
- No >> Visually check the wiring harness connection of diagnosis sensor unit. If the harness connection check result is OK, replace diagnosis sensor unit.

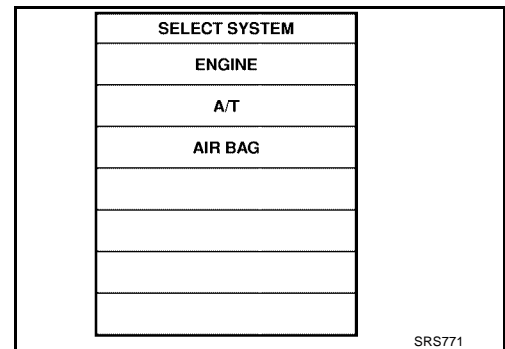

5. CHECK HARNESS CONNECTION

Is harness connection between warning lamp and diagnosis sensor unit OK?

OK or NG

- OK >> Replace diagnosis sensor unit.
- NG >> Connect "AIR BAG" warning lamp and diagnosis sensor unit connector properly. If "AIR BAG" warning lamp still does not go off, replace harness.

TROUBLE DIAGNOSIS

Trouble Diagnoses: "AIR BAG" Warning Lamp Does Not Turn On DIAGNOSTIC PROCEDURE 7

EHS000KY

1. CHECK "METER" FUSE

Check the 10A meter fuse [No. 14, located in the fuse block (J/B)] .
Refer to [PG-3, "POWER SUPPLY ROUTING CIRCUIT"](#) .

OK or NG

OK >> GO TO 3.
NG >> GO TO 2.

2. CHECK "METER" FUSE AGAIN

Replace 10A meter fuse [No. 14, located in the fuse block (J/B)] and turn ignition switch ON.

Does the meter fuse blow again?

Yes >> Repair the related harness.
No >> **INSPECTION END.**

3. CHECK HARNESS CONNECTION BETWEEN DIAGNOSIS SENSOR UNIT AND COMBINATION METER

Disconnect diagnosis sensor unit connector and turn ignition switch ON.

● Does "AIR BAG" warning lamp turn on?

Yes or No

Yes >> Replace diagnosis sensor unit.
No >> Check the ground circuit of "AIR BAG" warning lamp.

DRIVER AIR BAG MODULE

PFK:K8510

EHS000KZ

DRIVER AIR BAG MODULE

Removal and Installation

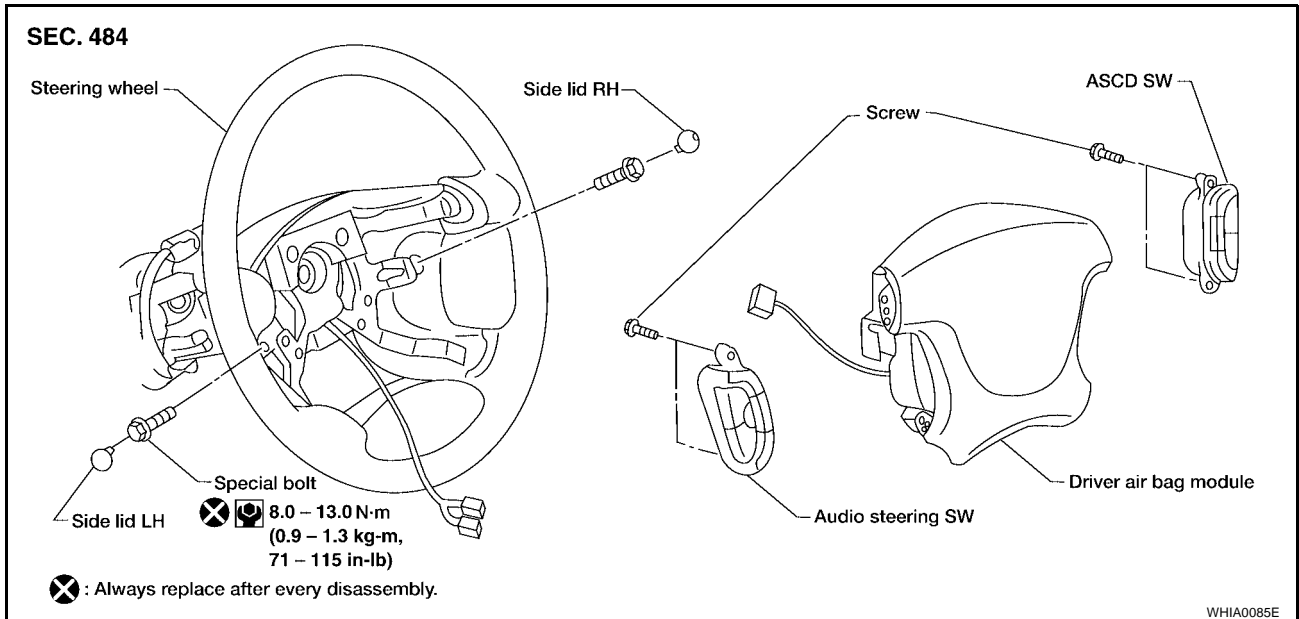

REMOVAL

CAUTION:

- Do not attempt to repair or replace damaged direct-connect driver air bag module connectors. If a direct-connect harness connector is damaged, the spiral cable must be replaced.
 - Before servicing SRS, turn the ignition switch off, disconnect both battery cables and wait at least 3 minutes.
 - Always work from the side of driver air bag module.
1. Remove the side lids.
 2. Remove the right and left side special hex head bolts.

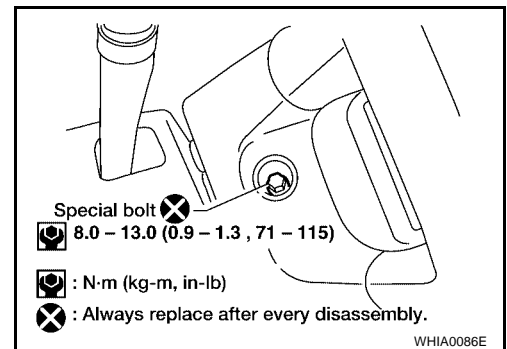

3. Disconnect the steering wheel switches sub-harness connector.
4. Disconnect the air bag harness connectors, and remove the air bag module.
 - For removal/installation of the direct-connect SRS connectors, refer to [SRS-7, "Direct-connect SRS Component Connectors"](#).

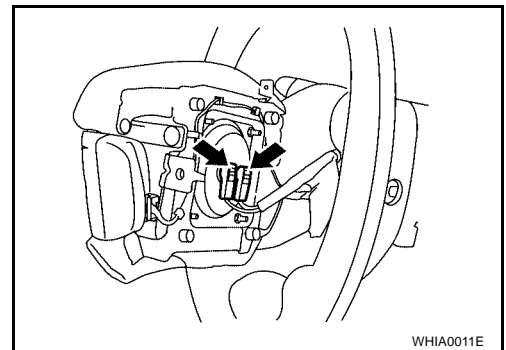

DRIVER AIR BAG MODULE

5. Remove the steering switch from the air bag module.

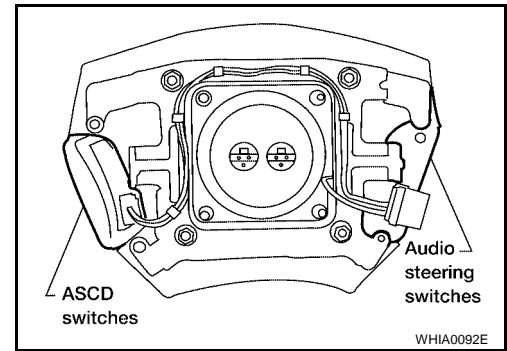

CAUTION:

- Always work from the side of driver air bag module.
- Always place driver air bag module with pad side facing upward.
- Do not insert any foreign objects (screwdriver, etc.) into driver air bag module.
- Do not attempt to disassemble driver air bag module.
- Do not use old bolts after removal; replace with new bolts.

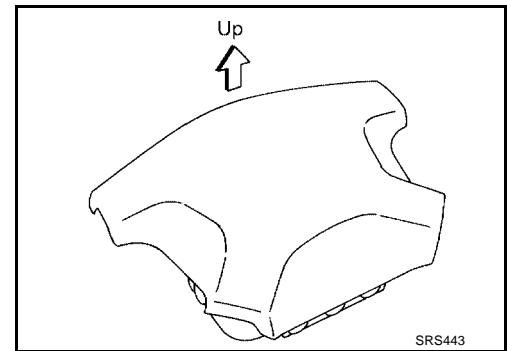

- Do not expose the driver air bag module to temperatures exceeding 90°C (194°F).
- Replace driver air bag module if it has been dropped or sustained an impact.
- Do not allow oil, grease or water to come in contact with the front passenger air bag module.

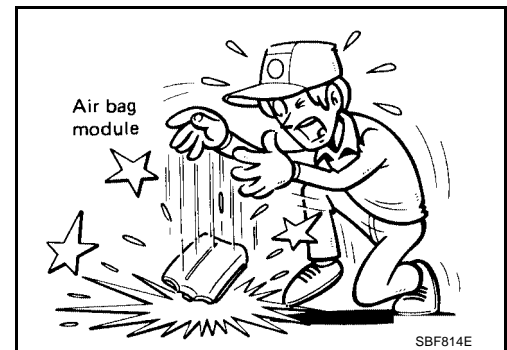

INSTALLATION

To install, reverse the removal procedure.

- For removal/installation of the direct-connect SRS connectors, refer to [SRS-7, "Direct-connect SRS Component Connectors"](#).
- For installing the air bag module, tighten the special bolts with the center of the horn pad pressed to make the contacts (RH/LH) ON.
- After the work is completed, perform self-diagnosis to check that no malfunction is detected. Refer to [SRS-19, "SRS Operation Check"](#).

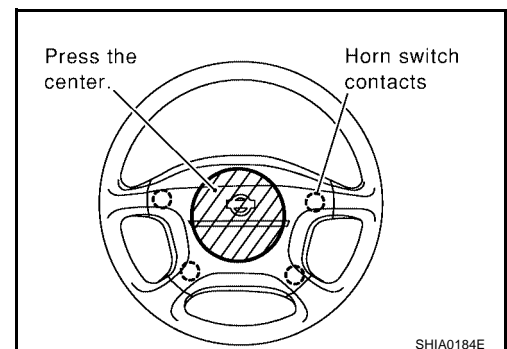

SPIRAL CABLE

PF2:25554

SPIRAL CABLE

Removal and Installation

EHS000L0

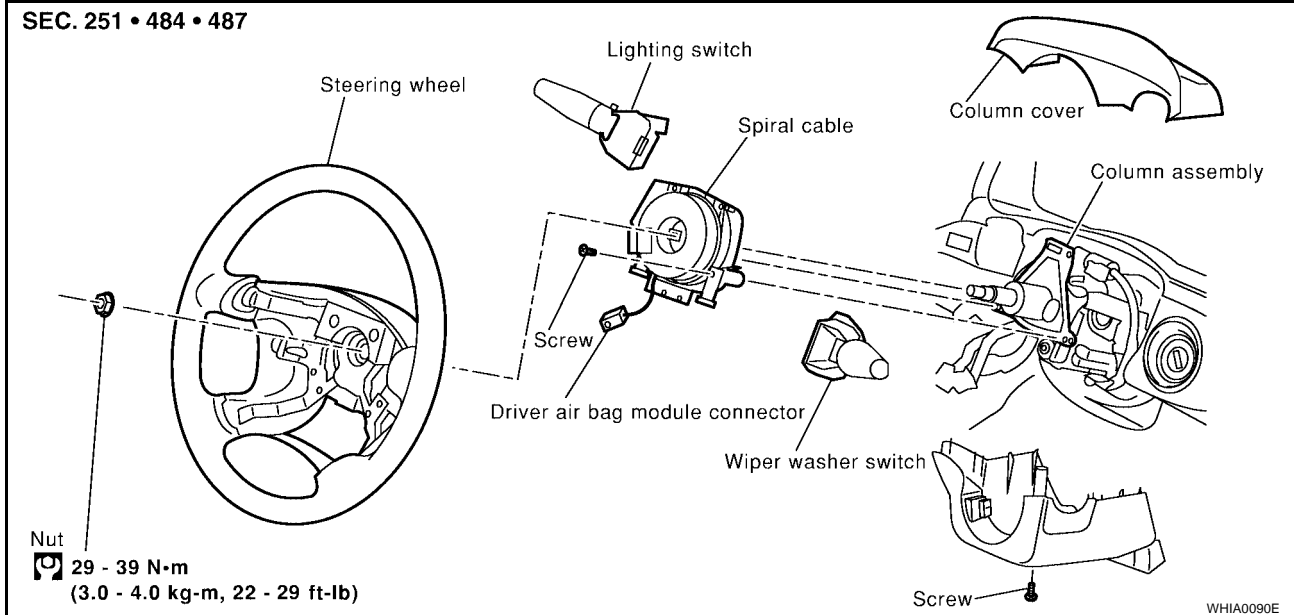

REMOVAL

CAUTION:

- Before servicing SRS, turn the ignition switch off, disconnect both battery cables and wait at least 3 minutes.

1. Remove driver air bag module. Refer to [SRS-39, "Removal and Installation"](#).
2. Set the steering wheel in the neutral position.
3. Disconnect the horn switch connector.
4. Remove the column cover. Refer to [IP-10, "INSTRUMENT PANEL ASSEMBLY"](#).
5. Disconnect the spiral cable connector.

CAUTION:

Do not tap or bump the steering wheel.

6. Remove steering wheel with steering wheel puller. Be careful not to over-tighten puller on steering wheel.

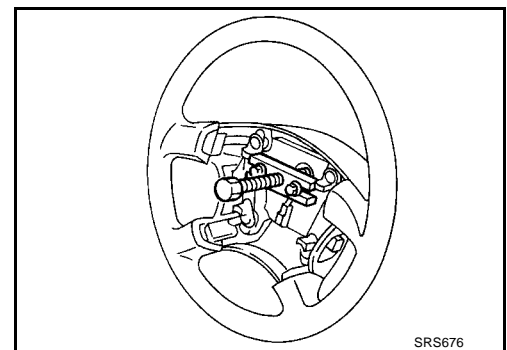

7. Remove the spiral cable fixing screws, remove the spiral cable.

CAUTION:

- Do not attempt to disassemble spiral cable.
- Do not apply lubricant to the spiral cable.

8. Remove the wiper washer switch and lighting switch from the spiral cable.

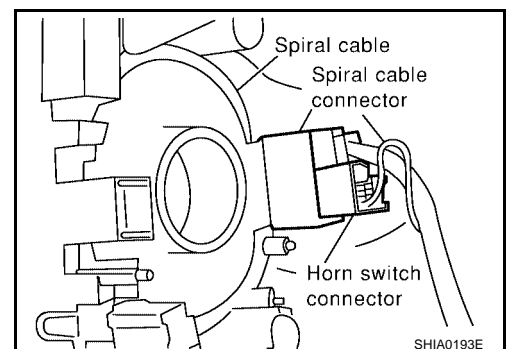

A
B
C
D
E
F
G

SRS

I
J
K
L
M

SPIRAL CABLE

CAUTION:

- The spiral cable may snap due to steering operation if the cable is installed in an improper position.
- Also, with the steering linkage disconnected the cable may snap by turning the steering wheel beyond the limited number of turns. The spiral cable can be turned counterclockwise about 2.5 turns from the right end position.

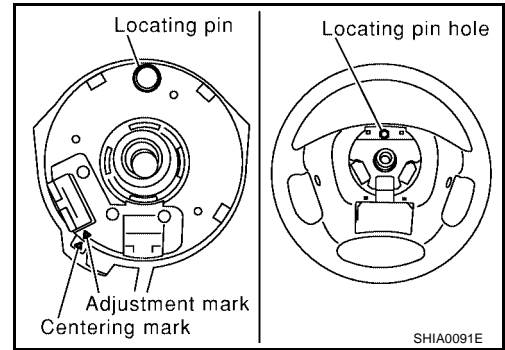

INSTALLATION

To install, reverse the removal procedure.

- After the work is completed, perform self-diagnosis to check that no malfunction is detected. Refer to [SRS-19, "SRS Operation Check"](#).

FRONT PASSENGER AIR BAG MODULE

FRONT PASSENGER AIR BAG MODULE

PFM:K8515

Removal and Installation

EHS000L1

The passenger air bag module originally installed in the vehicle uses direct-connect style harness connectors. Service replacement passenger air bag modules use tab-locking style harness connectors. If the passenger air bag module is replaced or if the direct-connect harness connectors are damaged, the vehicle wiring harness must be modified to allow connection of the service replacement passenger air bag module. Refer to [SRS-44, "WIRING HARNESS MODIFICATION"](#) for wiring harness modification procedure.

REMOVAL

CAUTION:

- Do not attempt to repair or replace damaged direct-connect front passenger air bag module connectors. If a direct-connect harness connector is damaged, the front passenger air bag must be replaced and the wiring harness modified.
 - Before servicing SRS, turn the ignition switch off, disconnect both battery cables and wait at least 3 minutes.
 - Always work from the side of or under front passenger air bag module.
1. Remove the glove box. Refer to [IP-14, "Glove Box"](#).
 2. Remove cluster lid C. Refer to [IP-12, "Cluster Lid C"](#).
 3. Remove cluster lid D. Refer to [IP-12, "Cluster Lid D"](#).
 4. Remove the side ventilator grille RH. Refer to [ATC-117, "Side Ventilator Grille RH"](#) (auto A/C) or [MTC-78, "Side Ventilator Grille RH"](#) (manual A/C).
 5. Remove screws retaining instrument panel pad assembly.
 6. Remove hex head bolt (through glove box opening) retaining front passenger air bag module to instrument panel crossmember.
 7. Remove instrument panel pad and front passenger air bag module assembly from opening in instrument panel. Rest air bag module on the front edge of the instrument panel opening (crossmember) taking care to not allow module to hang by the connected wiring.

CAUTION:

- Do not allow the front passenger air bag module to hang by the connected wires.

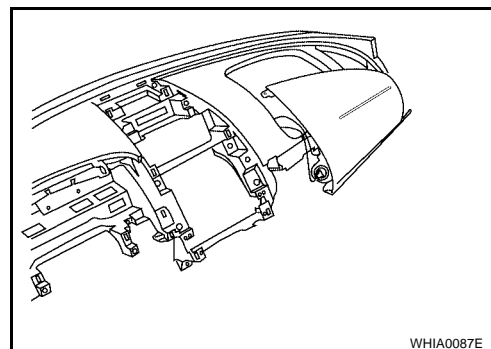

8. Disconnect the passenger air bag module electrical connector(s) and remove the instrument panel pad and front passenger air bag module assembly from the vehicle.
 - For removal/installation of the direct-connect SRS connectors, refer to [SRS-7, "Direct-connect SRS Component Connectors"](#).

FRONT PASSENGER AIR BAG MODULE

CAUTION:

- Always place front passenger air bag module with caution label side facing upward.
- Do not insert any foreign objects (screwdriver, etc.) into front passenger air bag module.
- Do not attempt to disassemble front passenger air bag module.
- Do not use old bolt after removal; replace with new bolt.

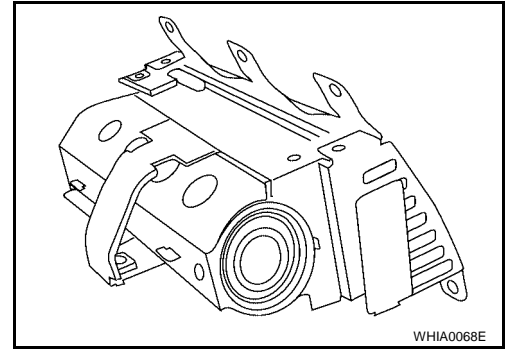

- Replace front passenger air bag module if it has been dropped or sustained an impact.
- Do not expose the front passenger air bag module to temperatures exceeding 90°C (194°F).
- Do not allow oil, grease or water to come in contact with the front passenger air bag module.

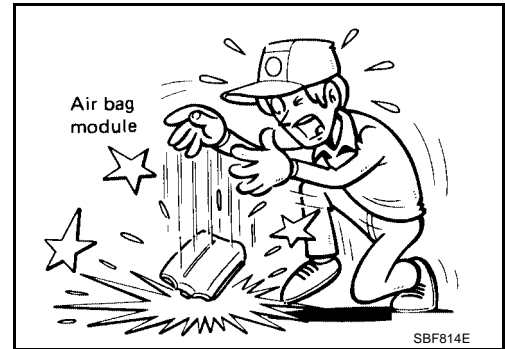

INSTALLATION

Original Passenger Air Bag Module

To install, reverse the removal procedure.

- For removal/installation of the direct-connect SRS connectors, refer to [SRS-7, "Direct-connect SRS Component Connectors"](#).

CAUTION:

- Always work from the side of or under front passenger air bag module.
- After the work is completed, perform self-diagnosis to check that no malfunction is detected. Refer to [SRS-19, "SRS Operation Check"](#).

Service Replacement Passenger Air Bag Module

1. Untape yellow 4-pin service replacement air bag connector from the main harness.
2. Position the front passenger air bag module and instrument panel pad assembly in the instrument panel.
3. Install the hex head bolt to secure front passenger air bag module to the instrument panel crossmember.
4. Install screws to secure the instrument panel pad.
5. Clip the front passenger air bag module connector to the mounting bracket.
6. Install the side ventilator grille RH. Refer to [ATC-117, "Side Ventilator Grille RH"](#) (auto A/C) or [MTC-78, "Side Ventilator Grille RH"](#) (manual A/C).
7. Install cluster lid D. Refer to [IP-12, "Cluster Lid D"](#).
8. Install cluster lid C. Refer to [IP-12, "Cluster Lid C"](#).
9. Install the glove box. Refer to [IP-14, "Glove Box"](#).
10. Connect the front passenger air bag module harness connector to yellow 4-pin service replacement air bag connector.

CAUTION:

- Always work from the side of or under front passenger air bag module.
- After the work is completed, perform self-diagnosis to check that no malfunction is detected. Refer to [SRS-19, "SRS Operation Check"](#).

WIRING HARNESS MODIFICATION

The passenger air bag module originally installed in the vehicle uses direct-connect style harness connectors. Service replacement passenger air bag modules use tab-locking style harness connectors. If the passenger

FRONT PASSENGER AIR BAG MODULE

air bag module is replaced or if the direct-connect harness connectors are damaged, the vehicle wiring harness must be modified to allow connection of the service replacement passenger air bag module.

NOTE:

The wiring harness modification is to be performed only if the vehicle is equipped with the original passenger air bag which uses direct-connect harness connectors. If the passenger air bag is to be replaced in a vehicle that has already had the service replacement passenger air bag installed, the wiring harness modification is not required.

CAUTION:

- Do not attempt to repair or replace damaged direct-connect front passenger air bag module connectors. If a direct-connect harness connector is damaged, the front passenger air bag must be replaced and the wiring harness modified.
- Before servicing SRS, turn the ignition switch off, disconnect both battery cables and wait at least 3 minutes.
- Always work from the side of or under front passenger air bag module.
- After the work is completed, perform self-diagnosis to check that no malfunction is detected. Refer to [SRS-19, "SRS Operation Check"](#).

1. Locate the yellow and orange direct-connect passenger air bag module harness connectors.
2. Use wire cutters to cut back both previously used direct-connect passenger air bag module harness connectors from the vehicle wiring harness approximately 50 mm (1.9 in) from the connectors.
3. Remove approximately 150 mm (5.9 in) of the vehicle harness covering from the cut end.
4. Slide a piece of dual-wall heat shrink tubing (provided in the passenger air bag service kit) onto each wire of the previously used vehicle wiring harness.

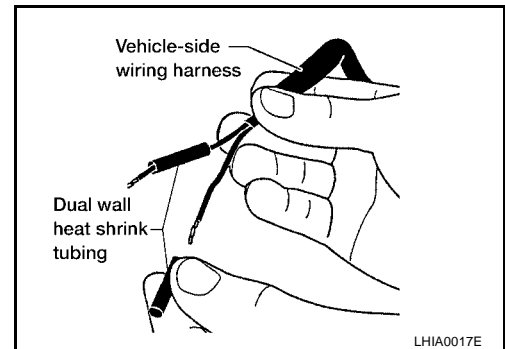

5. Fold each wire back and insert into the end of the heat shrink tubing so that the end of the wire is approximately centered in the heat shrink tubing.

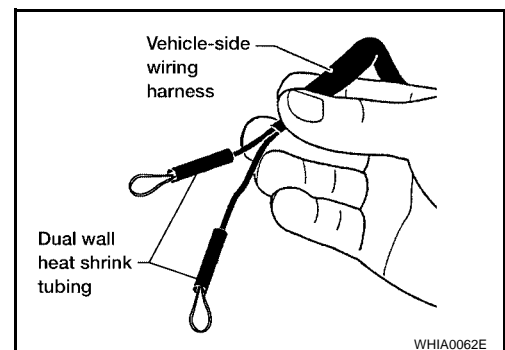

6. Use a heat gun to shrink the heat shrink tubing and seal the wire.
7. Use electrical tape to secure the modified circuits to the outside of the wiring harness.

FRONT PASSENGER AIR BAG MODULE

8. Locate the front passenger air bag service replacement connector that is taped back to the main harness. Unwrap the tape to access the yellow service replacement connector.

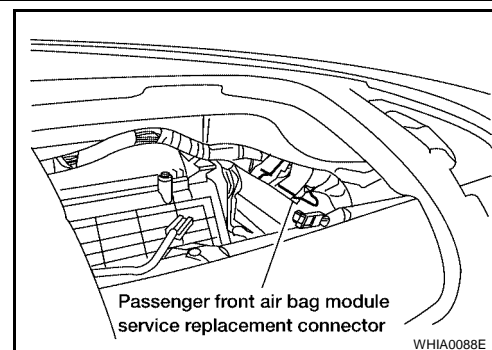

FRONT SIDE AIR BAG MODULE

PPF:K8EH0

EHS000L2

FRONT SIDE AIR BAG MODULE

Removal

WARNING:

Removal of front side air bag module should only be done to allow deployment of front side air bag module prior to disposal of seatback assembly.

Only complete seatback assemblies can be replaced. Refer to [SE-16, "Removal of seatback assembly"](#).

CAUTION:

- Before servicing SRS, turn the ignition switch off, disconnect both battery cables and wait at least 3 minutes.
 - Always work from the rear of the front side air bag module.
1. Remove the front seat. Refer to [SE-15, "REMOVAL"](#).
 2. Remove the seatback trim and pad. Refer to [SE-15, "SEAT-BACK TRIM AND PAD"](#).
 3. Remove the seatback rear finisher, and remove the retainers securing the seat cushion trim. Refer to [SE-16, "SEAT CUSHION TRIM AND PAD"](#).
 4. Remove air bag module harness clips.
 5. Remove the special fasteners coated with bonding agent from the front side air bag module, and remove the front side air bag module.

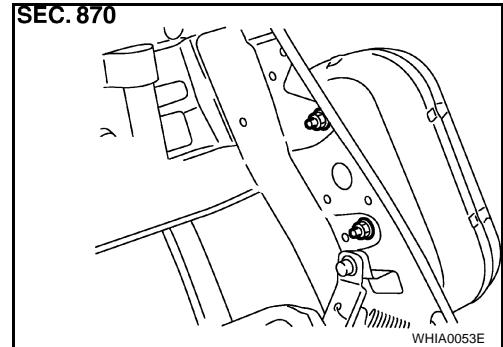

CAUTION:

- When using a clip removal tool to remove the seatback board, take care not to damage the harness for front side air bag module.
- Always place the front side air bag module standing with the stud bolt side facing down.
- Do not insert any foreign objects (screwdrivers, etc.) into front side air bag module.
- Do not attempt to disassemble front side air bag module.

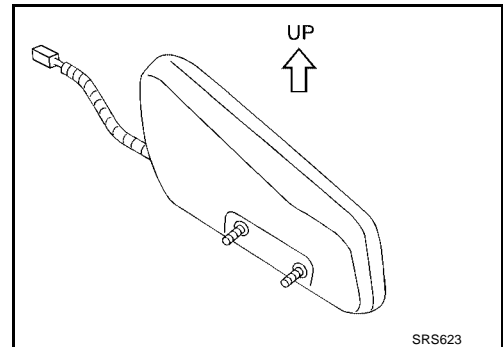

- Replace front seatback assembly (side air bag module) if it has been dropped or sustained an impact.
- Do not expose front seatback assembly (side air bag module) to temperatures exceeding 90°C (194°F).
- Do not allow oil, grease or water to come in contact with the front side air bag module.
- After front side air bag module inflates, front seatback assembly must be replaced.

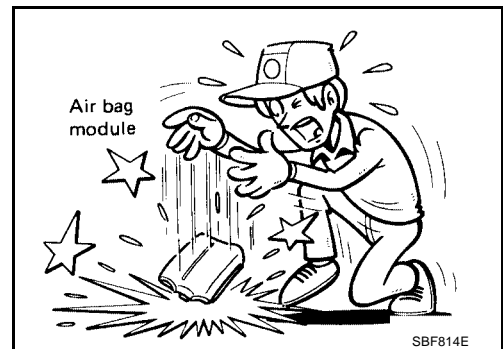

SIDE CURTAIN AIR BAG MODULE

SIDE CURTAIN AIR BAG MODULE

PF9:985P0

Removal and Installation

EHS000L3

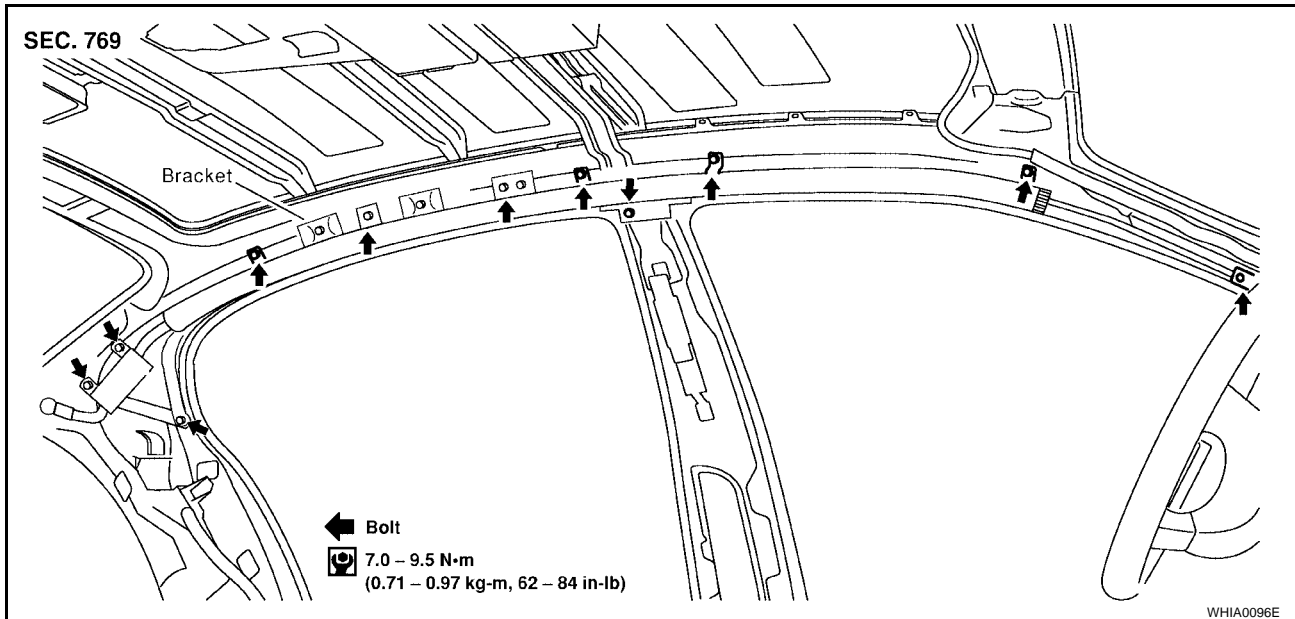

REMOVAL

CAUTION:

- Do not attempt to repair or replace damaged direct-connect side curtain air bag module connectors. If a direct-connect harness connector is damaged, the harness must be replaced.
 - Before servicing SRS, turn the ignition switch off, disconnect both battery cables and wait at least 3 minutes.
 - Always work from the side of the side curtain air bag module.
1. Remove headlining. Refer to [EI-33, "Removal and Installation"](#).
 2. Remove three rearmost side curtain air bag inflator fixing bolts, and unhook the side curtain air bag inflator.
 3. Disconnect side curtain air bag connector.
 - For removal/installation of the direct-connect SRS connectors, refer to [SRS-7, "Direct-connect SRS Component Connectors"](#).
 4. Unclip wiring harness from side curtain air bag module bracket.
 5. Remove side curtain air bag module fixing bolts and remove the side curtain air bag module.

CAUTION:

- Always place the side curtain air bag module with the warning label facing upward.
- Do not attempt to disassemble side curtain air bag module.
- Do not insert any foreign objects (screwdriver, etc.) into air bag module connector.

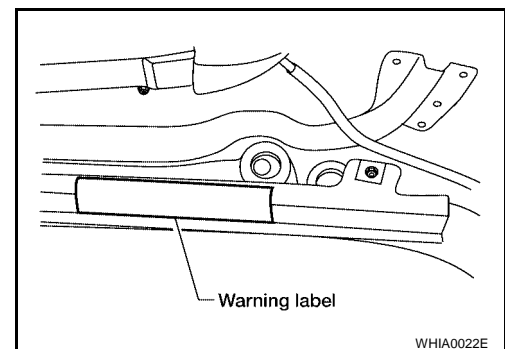

SIDE CURTAIN AIR BAG MODULE

- Replace side curtain air bag module if it has been dropped or sustained an impact.
- Do not expose the air bag module to temperatures exceeding 90°C (194°F).
- Do not allow oil, grease or water to come in contact with the side curtain air bag module.

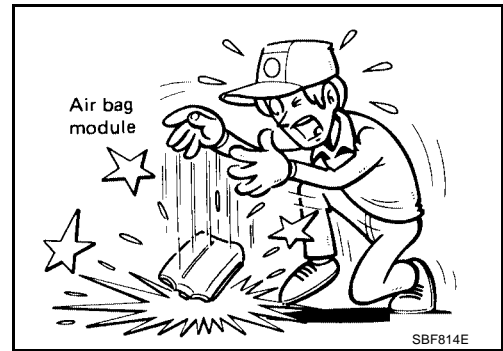

INSTALLATION

To install, reverse the removal procedure.

- For removal/installation of the direct-connect SRS connectors, refer to [SRS-7, "Direct-connect SRS Component Connectors"](#).

CAUTION:

- Always work from the side of the side curtain air bag module.
- After replacement of side curtain air bag module, perform self-diagnosis to check that no malfunction is detected. Refer to [SRS-19, "SRS Operation Check"](#).

A
B
C
D
E
F
G
I
J
K
L
M

SRS

CRASH ZONE SENSOR

PFP:98531

CRASH ZONE SENSOR

Removal and Installation REMOVAL

EHS000L4

CAUTION:

- Before servicing SRS, turn the ignition switch off, disconnect both battery cables and wait at least 3 minutes.
1. Remove front grille. Refer to [EI-17, "Removal and Installation"](#).
 2. Remove crash zone sensor connector.
 3. Remove crash zone sensor fixing nuts.

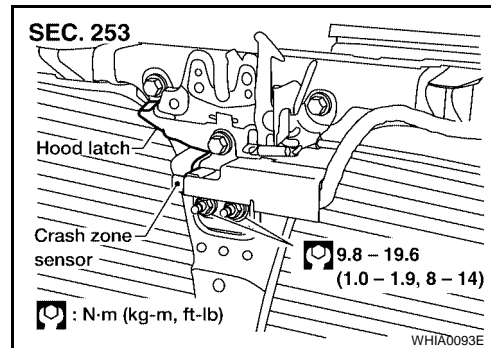

CAUTION:

- Replace crash zone sensor if it has been dropped or sustained an impact.
- Do not attempt to disassemble crash zone sensor.

INSTALLATION

To install, reverse the removal procedure.

CAUTION:

- Check crash zone sensor for proper installation.
- After the work is complete, perform self-diagnosis to check that no malfunction is detected. Refer to [SRS-19, "SRS Operation Check"](#).

SIDE AIR BAG (SATELLITE) SENSOR

PFP:98830

SIDE AIR BAG (SATELLITE) SENSOR

Removal and Installation REMOVAL

EHS000L5

CAUTION:

- Before servicing SRS, turn the ignition switch off, disconnect both battery cables and wait at least 3 minutes.
- 1. Remove seat belt pre-tensioner. Refer to [SB-4, "Removal and Installation of Front Seat Belt"](#).
- 2. Remove side air bag (satellite) sensor fixing nuts.
- 3. Remove the side air bag (satellite) sensor connector.

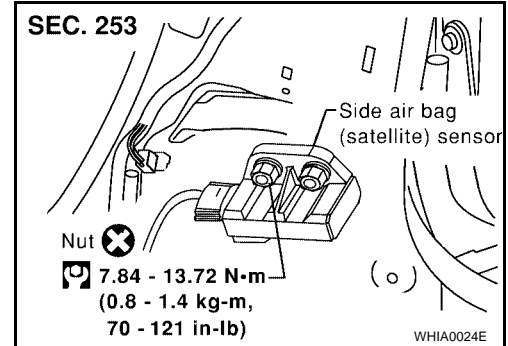

CAUTION:

- Do not use old nuts; replace with new ones.
- Check side air bag (satellite) sensor to ensure it is free of deformities, dents, cracks or rust. If it shows any visible signs of damage, replace it with new one.
- Do not attempt to disassemble side air bag (satellite) sensor.
- Replace side air bag (satellite) sensor if it has been dropped or sustained an impact.

INSTALLATION

To install, reverse the removal procedure.

CAUTION:

- Check side air bag (satellite) sensor for proper installation.
- After replacement of side air bag (satellite) sensor, perform self-diagnosis to check that no malfunction is detected. Refer to [SRS-19, "SRS Operation Check"](#).

FRONT SEAT BELT PRE-TENSIONER

FRONT SEAT BELT PRE-TENSIONER

PF:86884

Removal and Installation

EHS000L6

For removal and installation procedures, refer to [SB-4, "Removal and Installation of Front Seat Belt"](#) .

DIAGNOSIS SENSOR UNIT

PFP:28556

EHS000L7

DIAGNOSIS SENSOR UNIT

Removal and Installation

REMOVAL

CAUTION:

- Before servicing SRS, turn the ignition switch off, disconnect both battery cables and wait at least 3 minutes.
1. Disconnect each harness connector for the air bag module and seat belt pre-tensioner.
 2. Remove center console. Refer to [IP-10, "INSTRUMENT PANEL ASSEMBLY"](#).
 3. Disconnect diagnosis sensor unit connectors.
 4. Remove special hex bolts from the diagnosis sensor unit.

CAUTION:

- Do not use old bolts. Replace with new ones.
- Check diagnosis sensor unit bracket to ensure it is free of deformities, dents, cracks or rust. If it shows any visible signs of damage, replace with new one.
- Replace diagnosis sensor unit if it has been dropped or sustained an impact.

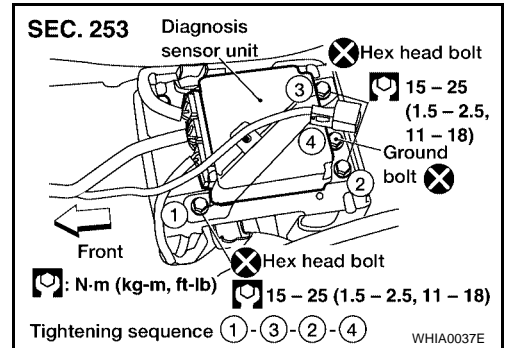

INSTALLATION

To install, reverse the removal procedure.

NOTE:

The diagnosis sensor unit must always be installed with the arrow mark "←" pointing toward the front of the vehicle for proper operation.

CAUTION:

- Check the diagnosis sensor unit for proper installation.
- After replacement of diagnosis sensor unit, perform self-diagnosis to check that no malfunction is detected. Refer to [SRS-19, "SRS Operation Check"](#).

ECU DISCRIMINATED NO.

After replacing the diagnosis sensor unit, confirm that the diagnosis sensor unit identification is correct for the vehicle as equipped. Refer to [SRS-17, "DIAGNOSIS MODE FOR CONSULT-II"](#).

A
B
C
D
E
F
G
I
J
K
L
M

SRS

DISPOSAL OF AIR BAG MODULE AND SEAT BELT PRE-TENSIONER

DISPOSAL OF AIR BAG MODULE AND SEAT BELT PRE-TENSIONER

PF0:00014

Caution for Air Bag Module and Seat Belt Pre-tensioner

EHS000L8

- Before disposing of air bag module, seat belt pre-tensioner or vehicle equipped with such systems, deploy the systems. If such systems have already been deployed due to an accident, dispose of them as indicated in "[SRS-60, "DISPOSING OF AIR BAG MODULE AND SEAT BELT PRE-TENSIONER"](#)".
- When deploying the air bag module or seat belt pre-tensioner, always use the Special Service Tool; Deployment tool [KV99106400 (J38381)].
- When deploying the air bag module or seat belt pre-tensioner, stand at least 5 m (16 ft) away from the deployment component.
- When deploying air bag module or seat belt pre-tensioner, a fairly loud noise is made, followed by smoke being released. The smoke is not poisonous, however, be careful not to inhale smoke since it irritates the throat and can cause choking.
- Always deploy one air bag module at a time.
- Due to heat, leave air bag module unattended for more than 30 minutes after deployment. Also leave seat belt pre-tensioner unattended for more than 10 minutes after deployment.
- Be sure to wear gloves when handling a deployed air bag module or seat belt pre-tensioner.
- Never apply water to the deployed air bag module or seat belt pre-tensioner.
- Wash your hands clean after finishing work.
- Place the vehicle outdoors with an open space of at least 6 m (20 ft) on all sides when deploying air bag module or seat belt pre-tensioner while mounted in vehicle.
- Use a voltmeter to make sure the vehicle battery is fully charged.
- Do not dispose of the air bag module or seat belt pre-tensioner undeployed.

CHECKING DEPLOYMENT TOOL

Connecting to Battery

CAUTION:

The battery must show voltage of 9.6V or more.

Remove the battery from the vehicle and place it on dry wood blocks approximately 5 m (16 ft) away from the vehicle.

- Wait 3 minutes after the vehicle battery is disconnected before proceeding.
- Connect red clip of deployment tool to battery positive terminal and black clip to negative terminal.

Make sure the polarity is correct. The right side lamp in the tool marked "deployment tool power" should glow with a green light. If the right side lamp glows red, reverse the connections to the battery.

Deployment Tool Check

Press the deployment tool switch to the ON position. The left side lamp in the tool, marked "air bag connector voltage" should illuminate. If it does not illuminate, replace the tool.

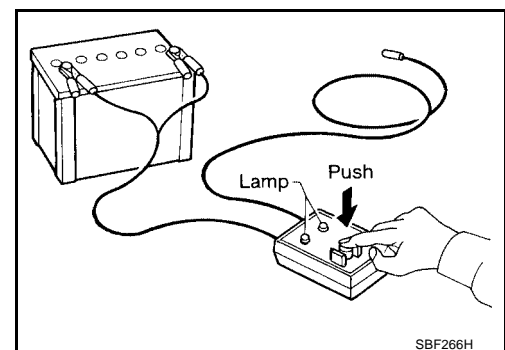
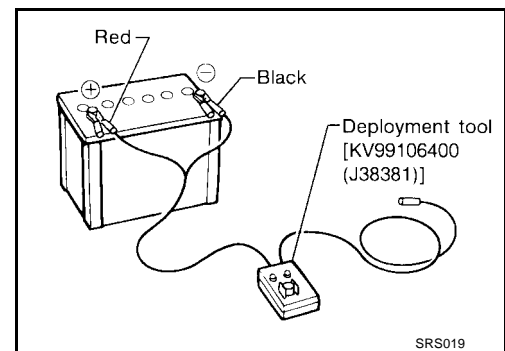

DISPOSAL OF AIR BAG MODULE AND SEAT BELT PRE-TENSIONER

Air Bag Deployment Tool Lamp Illumination Chart (Battery connected)

Switch operation	Left side lamp, green* "AIR BAG CONNECTOR VOLTAGE"	Right side lamp, green* "DEPLOYMENT TOOL POWER"
OFF	OFF	ON
ON	ON	ON

*: If this lamp glows red, the tool is connected to the battery incorrectly. Reverse the connections and make sure the lamp glows green.

DEPLOYMENT PROCEDURES FOR AIR BAG MODULE (OUTSIDE OF VEHICLE)

Unless the vehicle is being scrapped, deploying the air bag in the vehicle is not recommended. This may cause damage to the vehicle interior.

Anchor air bag module bracket [KV99105300 (J41246)] in a vise secured to a firm foundation during deployment.

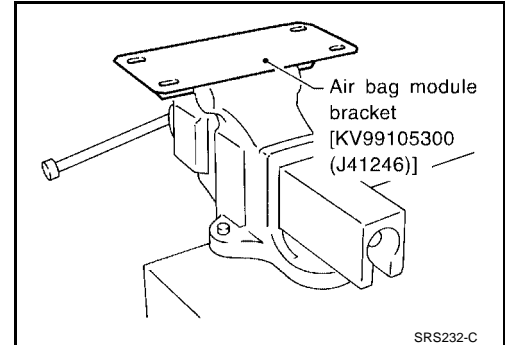

Deployment of Driver Air Bag Module (Outside of vehicle)

- Using wire, secure air bag module to air bag module bracket [SST: KV99105300 (J41246)] at two places.

CAUTION:

Use wire of at least 1 mm (0.04 in) diameter.

- Firmly secure air bag module bracket [SST: KV99105300 (J41246)] with air bag module attached, in a vise.

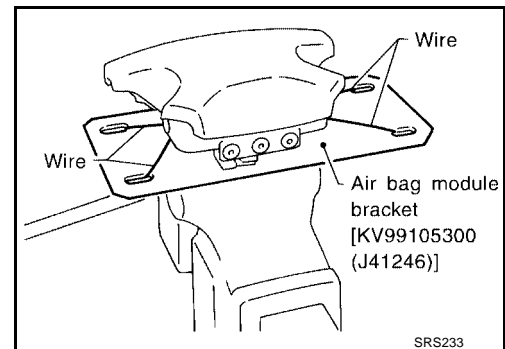

- Connect deployment tool [SST: KV99106400 (J38381)] to air bag module connector using deployment tool adapter (J38381-80).

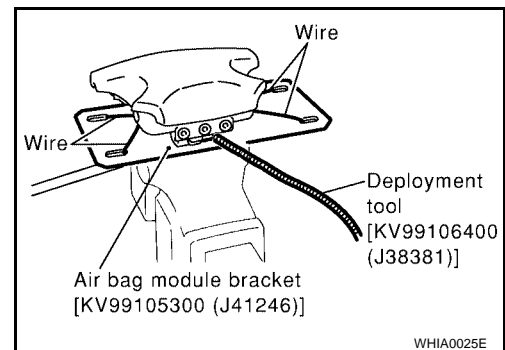

DISPOSAL OF AIR BAG MODULE AND SEAT BELT PRE-TENSIONER

4. Connect red clip of deployment tool to battery positive terminal and black clip to negative terminal.
5. The lamp on the right side of the tool, marked "deployment tool power", should glow green, not red.
6. Press the button on the deployment tool. The left side lamp on the tool, marked "air bag connector voltage", will illuminate and the air bag module will deploy.

CAUTION:

When deploying the driver air bag module, stand at least 5 m (16 ft) away from the air bag module.

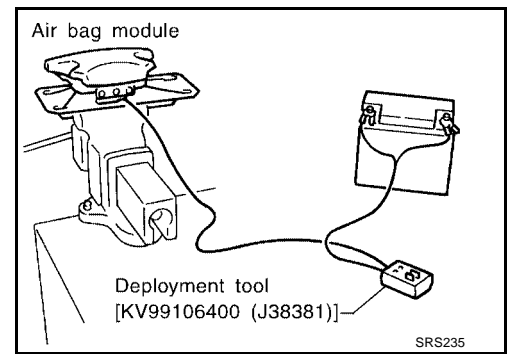

Deployment of Front Passenger Air Bag Module (Outside of vehicle)

1. Make an 8.5 mm (0.335 in) diameter hole in air bag module bracket [SST: KV99105300 (J41246)] at the position shown in figure.
2. Firmly secure air bag module bracket [SST: KV99105300 (J41246)] in a vise.

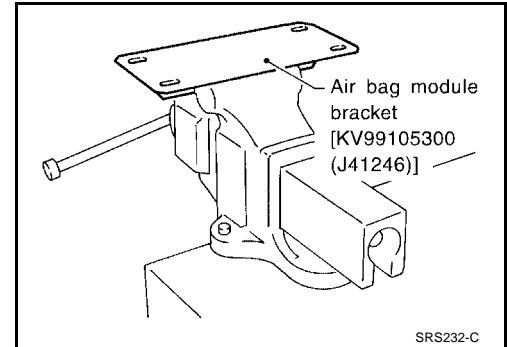

3. Match the two holes in air bag module bracket (held in vise) and front passenger air bag module and fix them with two bolts [M8 x 25 - 30 mm (0.98 - 1.18 in)].

CAUTION:

If a gap exists between front passenger air bag module and air bag module bracket, use a piece of wood inserted in the gap to stabilize the air bag module.

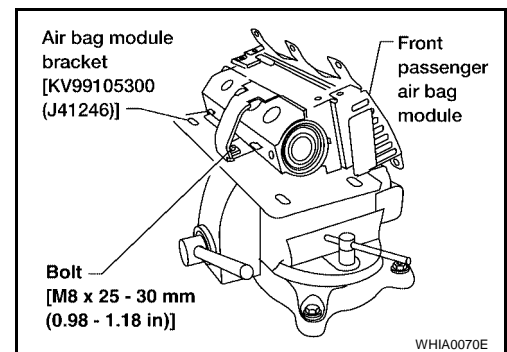

4. Connect deployment tool [SST: KV99106400 (J38381)] to front passenger air bag module. For service replacement front passenger air bag module, use deployment tool adapter (J38381-65).
5. Connect red clip of deployment tool to battery positive terminal and black clip to negative terminal.
6. The lamp on the right side of the tool, marked "deployment tool power", should glow green, not red.

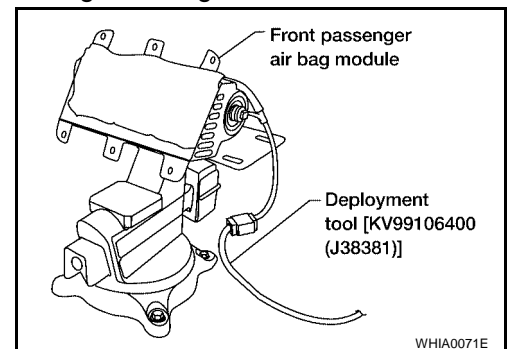

DISPOSAL OF AIR BAG MODULE AND SEAT BELT PRE-TENSIONER

- Press the button on the deployment tool. The left side lamp on the tool, marked "air bag connector voltage", will illuminate and the air bag module will deploy.

CAUTION:

- When deploying the front passenger air bag module, do not stand on the deploying side.
- Stand at least 5 m (16 ft) away from the air bag module.

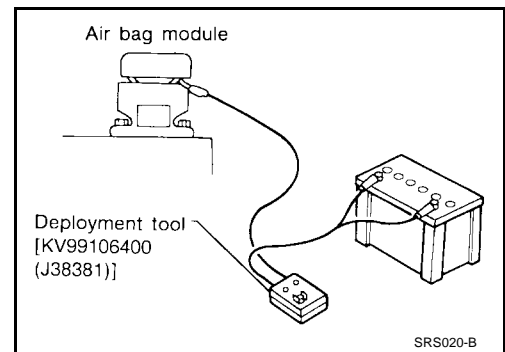

Deployment of Front Side Air Bag Module (Outside of vehicle)

- Make 6.5 mm (0.256 in) diameter holes in air bag module bracket [SST: KV99105300 (J41246)] at the position shown in figure.

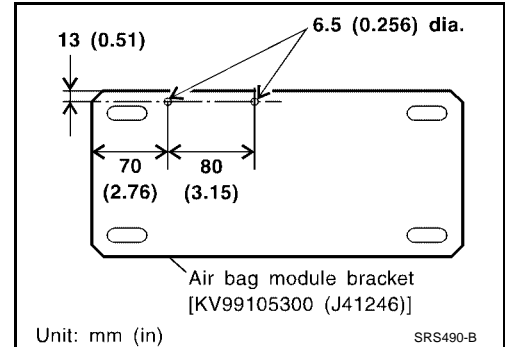

- Firmly secure air bag module bracket [SST: KV99105300 (J41246)] in a vise.
- Insert the stud bolts of side air bag module into the two holes in air bag module bracket (held in vise) and fix them with two M6 nuts.

CAUTION:

Side air bag module should be secured to air bag module bracket [SST: KV99105300 (J41246)] in a vise with stud bolt side facing down.

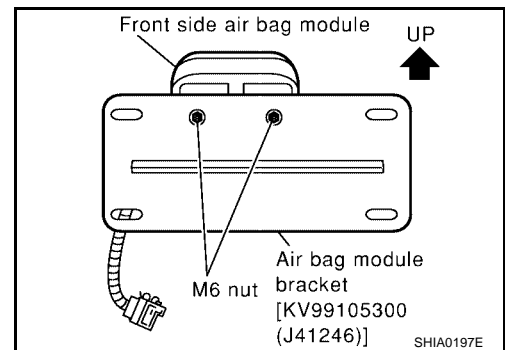

- Connect deployment tool [SST: KV99106400 (J38381)] connector to connector on air bag module using deployment tool adapter [SST: KV99109000 (J44230)].

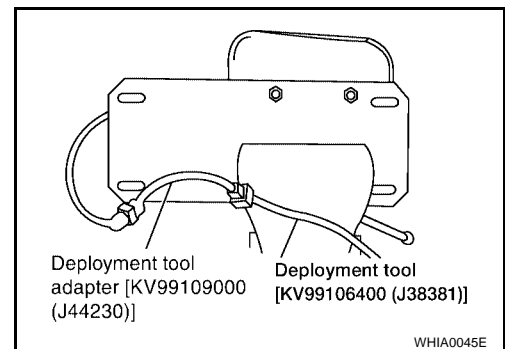

A
B
C
D
E
F
G
SRS
I
J
K
L
M

DISPOSAL OF AIR BAG MODULE AND SEAT BELT PRE-TENSIONER

5. Connect red clip of deployment tool to battery positive terminal and black clip to negative terminal.
6. The lamp on the right side of the tool, marked "deployment tool power", should glow green, not red.
7. Press the button on the deployment tool. The left side lamp on the tool, marked "air bag connector voltage", will illuminate and the air bag module will deploy.

CAUTION:

When deploying the front side air bag module, stand at least 5 m (16 ft) away from the air bag module.

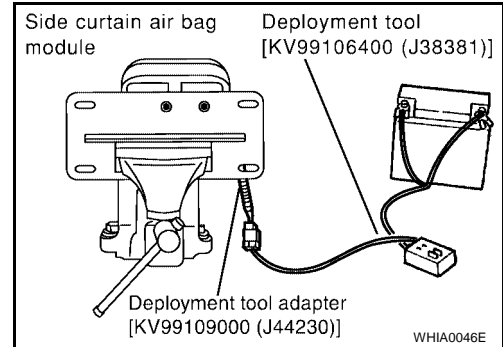

Deployment of Side Curtain Air Bag Module (Outside of vehicle)

1. Cut the inflator from side curtain air bag module.

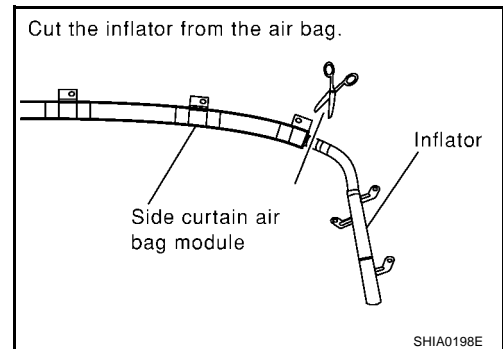

2. Connect deployment tool [SST: KV99106400 (J38381)] to the inflator using deployment tool adapter (J38381-80).

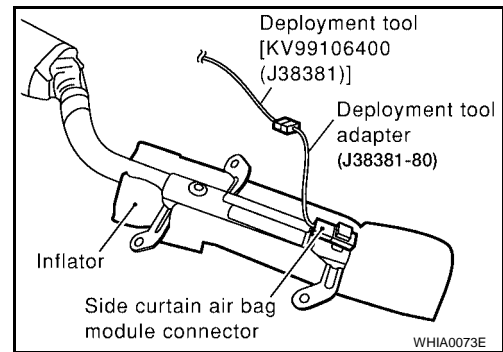

3. Put the inflator connected with the deployment tool [SST: KV99106400 (J38381)] into a tire without a wheel.

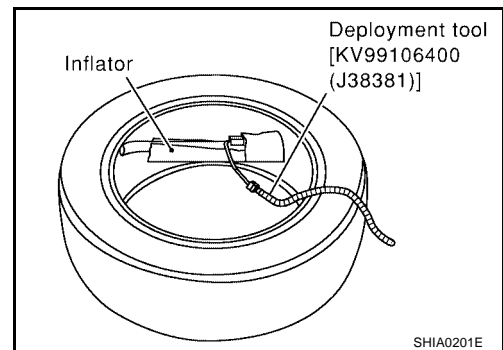

DISPOSAL OF AIR BAG MODULE AND SEAT BELT PRE-TENSIONER

- Put the tire with the inflator onto another tire without wheel. Add an additional tire without a wheel and then a tire mounted on a wheel on top.

CAUTION:

Tie all tires together with a strap in order keep them standing.

- Connect red clip of deployment tool to battery positive terminal and black clip to negative terminal.
- The lamp on the right side of the tool, marked "deployment tool power", should glow green, not red.
- Press the button on the deployment tool. The left side lamp on the tool, marked "air bag connector voltage", will illuminate and the air bag module will deploy.

CAUTION:

When deploying the side curtain air bag module, stand at least 5 m (16 ft) away from the side curtain air bag module.

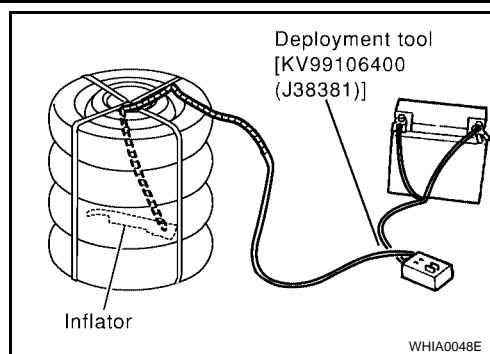

DEPLOYMENT PROCEDURES FOR SEAT BELT PRE-TENSIONER (OUTSIDE OF VEHICLE)

- Firmly grip pre-tensioner in a vise and cut off the webbing.

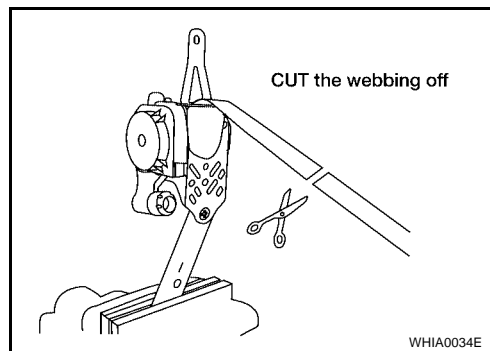

- Connect deployment tool [SST: KV99106400 (J38381)] connector to front seat belt pre-tensioner using deployment tool adapter (J38381-80).

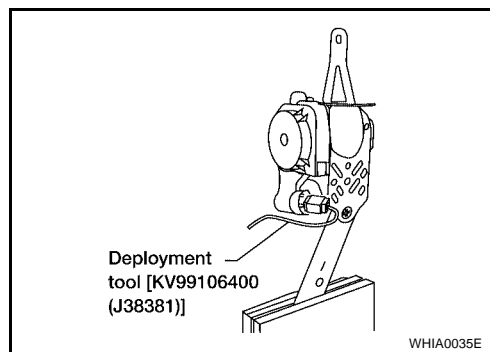

- Connect red clip of deployment tool to battery positive terminal and black clip to negative terminal.
- The lamp on the right side of the tool, marked "deployment tool power", should glow green, not red.
- Press the button on the deployment tool. The left side lamp on the tool, marked "seat belt pre-tensioner connector voltage", will illuminate and the seat belt pre-tensioner will deploy.

CAUTION:

When deploying the front seat belt pre-tensioner, stand at least 5 m (16 ft) away from the seat belt pre-tensioner.

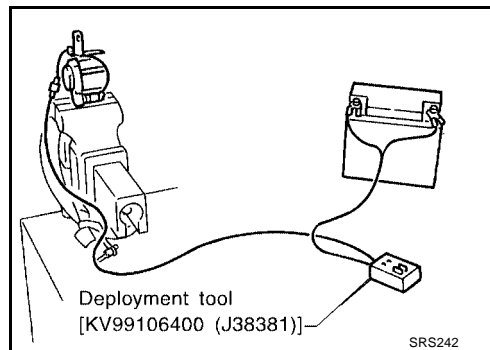

A
B
C
D
E
F
G
I
J
K
L
M

SRS

DISPOSAL OF AIR BAG MODULE AND SEAT BELT PRE-TENSIONER

DEPLOYMENT OF AIR BAG MODULE AND SEAT BELT PRE-TENSIONER WHILE MOUNTED IN VEHICLE

When disposing of a vehicle, deploy air bag module and seat belt pre-tensioners while they are mounted in vehicle.

CAUTION:

When deploying air bag module or seat belt pre-tensioner, ensure vehicle is empty.

1. Disconnect both the vehicle battery cables and wait 3 minutes.
2. Disconnect air bag module and seat belt pre-tensioner connector.
3. Connect deployment tool [SST: KV99106400 (J38381)] to air bag module or seat belt pre-tensioner.
For front driver air bag module, use deployment tool adapter (J38381-80).
For front passenger air bag module (service replacement), use deployment tool adapter (J38381-65).
For side curtain air bag module, use deployment tool adapter (J38381-80).
For side air bag module, use deployment tool adapter [SST: KV99109000 (J44230)].
4. Connect red clip of deployment tool to battery positive terminal and black clip to negative terminal.
5. The lamp on the right side of the tool, marked "deployment tool power", should glow green, not red.
6. Press the button on the deployment tool. The left side lamp on the tool, marked "air bag connector voltage", will illuminate and the air bag module or seat belt pre-tensioner will deploy.

CAUTION:

Activate only one air bag module or seat belt pre-tensioner at a time.

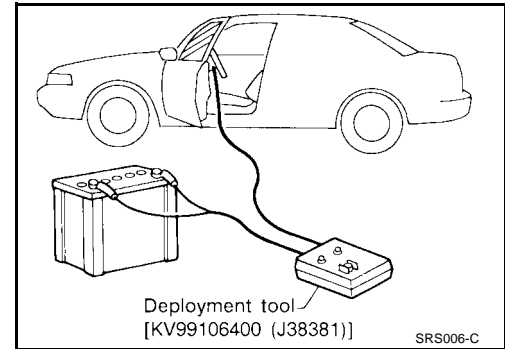

DISPOSING OF AIR BAG MODULE AND SEAT BELT PRE-TENSIONER

Deployed air bag module and seat belt pre-tensioner are very hot. Before disposing of air bag module or seat belt pre-tensioner, wait at least 30 minutes or 10 minutes, respectively. Seal them in a plastic bag before disposal.

CAUTION:

- Never apply water to a deployed air bag module or seat belt pre-tensioner.
- Be sure to wear gloves when handling a deployed air bag module or seat belt pre-tensioner.
- No poisonous gas is produced upon air bag module deployment. However, be careful not to inhale gas since it irritates the throat and can cause choking.
- Do not attempt to disassemble air bag module or seat belt pre-tensioner.
- Air bag module and seat belt pre-tensioner cannot be reused.
- Wash your hands clean after finishing work.

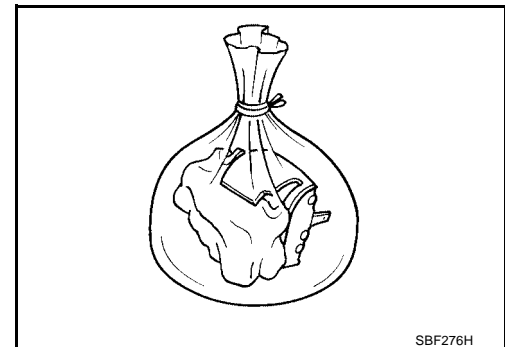

COLLISION DIAGNOSIS

PFP:00015

COLLISION DIAGNOSIS

For Frontal Collision

EHS000L9

To repair the SRS, perform the following steps.

WHEN SRS (EXCEPT THE FRONT SIDE AIR BAG AND SIDE CURTAIN AIR BAG MODULES) IS ACTIVATED IN A COLLISION

1. Replace the diagnosis sensor unit.
2. Remove the air bag modules (except the front side air bag modules and side curtain air bag modules), crash zone sensor assembly, bracket and seat belt pre-tensioner assemblies.
3. Check the SRS components using the table below:
 - Replace any SRS components showing visible signs of damage (dents, cracks and deformation).
4. Install new air bag modules (except the front side air bag modules and side curtain air bag modules) crash zone sensor assembly, bracket and seat belt pre-tensioner assemblies.
5. Conduct self-diagnosis using CONSULT-II or "AIR BAG" warning lamp. Refer to [SRS-19, "SRS Operation Check"](#) for details. Ensure entire SRS operates properly.

WHEN SRS IS NOT ACTIVATED IN A COLLISION

1. Check the SRS components using the table below:
 - Replace any SRS components showing visible signs of damage (dents, cracks and deformation).
2. Conduct self-diagnosis using CONSULT-II or "AIR BAG" warning lamp. Refer to [SRS-19, "SRS Operation Check"](#) for details. Ensure entire SRS operates properly.

SRS INSPECTION (FOR FRONTAL COLLISION)

Part	SRS is activated	SRS is NOT activated
Air bag module (driver and front passenger air bag module)	REPLACE Install with new bolts.	<ol style="list-style-type: none"> 1. Remove air bag module. Check harness cover and connectors for damage, terminals for deformities, and harness for binding. 2. Install driver air bag module into the steering wheel to check fit and alignment with the wheel. 3. Install passenger air bag module into the instrument panel to check fit with the instrument panel. 4. If no damage is found, reinstall with new bolts. 5. If damaged—REPLACE. Install air bag modules with new special bolts. Air bag modules must be deployed before disposal.
Crash zone sensor	REPLACE the crash zone sensor and bracket with new nuts.	<ol style="list-style-type: none"> 1. Remove the crash zone sensor. Check harness connectors for damage, terminals for deformities, and harness for binding. 2. Check for visible signs of damage (dents, cracks, deformation) of the crash zone sensor and bracket. 3. Install the crash zone sensor to check fit. 4. If no damage is found, reinstall with new nuts. 5. If damaged—REPLACE the crash zone sensor and bracket with new nuts.
Seat belt pre-tensioner assemblies	REPLACE Install seat belt pre-tensioner with new bolts.	<ol style="list-style-type: none"> 1. Remove seat belt pre-tensioners. Check harness cover and connectors for damage, terminals for deformities, and harness for binding. 2. Check belts for damage and anchors for loose mounting. 3. Check retractor for smooth operation. 4. Check seat belt adjuster for damage. 5. If no damage is found, reinstall seat belt pre-tensioner assembly. 6. If damaged—REPLACE. Install the seat belt pre-tensioners with new bolts. Seat belt pre-tensioners must be deployed before disposal.
Diagnosis sensor unit	REPLACE Install with new bolts.	<ol style="list-style-type: none"> 1. Check case for dents, cracks or deformities. 2. Check connectors for damage, and terminals for deformities. 3. If no damage is found, reinstall with new bolts and ground bolt. 4. If damaged—REPLACE. Install diagnosis sensor unit with new bolts and ground bolt.

SRS

COLLISION DIAGNOSIS

Part	SRS is activated	SRS is NOT activated
Steering wheel	<ol style="list-style-type: none"> 1. Visually check steering wheel for deformities. 2. Check harness (built into steering wheel) and connectors for damage, and terminals for deformities. 3. Install air bag module to check fit or alignment with steering wheel. 4. Check steering wheel for excessive free play. 5. If no damage is found, reinstall with nuts. 6. If damaged—REPLACE. 	
Spiral cable	<ol style="list-style-type: none"> 1. Visually check spiral cable and combination switch for damage. 2. Check connectors and protective tape for damage. 3. Check steering wheel for noise, binding or heavy operation. 4. If no damage is found, reinstall with screws. 5. If damaged—REPLACE. 	
Harness and connectors	<ol style="list-style-type: none"> 1. Check connectors for poor connection, damage, and terminals for deformities. 2. Check harness for binding, chafing, cuts, or deformities. 3. If no damage is found, reinstall the harness and connectors. 4. If damaged—REPLACE the damaged harness. Do not attempt to repair, splice or modify any SRS harness. 	
Instrument panel	<ol style="list-style-type: none"> 1. Visually check instrument panel for damage. 2. If no damage is found, reinstall the instrument panel. 3. If damaged—REPLACE the instrument panel with bolts. 	

For Side Collision

EHS000LA

To repair the SRS, perform the following steps.

WHEN SRS IS ACTIVATED IN THE SIDE COLLISION

1. Replace the following components:
 - Front seat back assembly (on the side on which side air bag is activated)
 - Diagnosis sensor unit
 - (LH and RH) side air bag (satellite) sensors
2. Check the SRS components and the related parts using the following table.
 - Replace any SRS components and the related parts showing visible signs of damage (dents, cracks, deformation).
3. Conduct self-diagnosis using CONSULT-II and “AIR BAG” warning lamp. Refer to [SRS-19. "SRS Operation Check"](#) for details. Ensure entire SRS operates properly.

WHEN SRS IS NOT ACTIVATED IN THE SIDE COLLISION

1. Check the SRS components and the related parts using the following table.
 - If the front seat back assembly is damaged, the front seat back assembly must be replaced.
2. Conduct self-diagnosis using CONSULT-II and “AIR BAG” warning lamp. Refer to [SRS-19. "SRS Operation Check"](#) for details. Ensure entire SRS operates properly.

COLLISION DIAGNOSIS

SRS INSPECTION (FOR SIDE COLLISION)

Part	Front side air bag and side curtain air bag are activated	Front side air bag and side curtain air bag are NOT activated
(LH or RH) side curtain air bag module	Replace the side curtain air bag module. (Repair the center pillar inner, etc. before installing new one if damaged.)	<ol style="list-style-type: none"> 1. Check for visible signs of damage (dents, tears, deformation) of the center pillar on the collision side. 2. If damaged— Remove the side curtain air bag module. 3. Check for visible signs of damaged (tears etc.) of the side curtain air bag module. 4. Check harness and connectors for damage, and terminals for deformities. 5. If no damage is found, reinstall the side curtain air bag module with new bolts. 6. If damaged—REPLACE the side curtain air bag module with new bolts. Air bag modules must be deployed before disposal.
Front (LH or RH) side air bag module	REPLACE front seat back assembly.	<ol style="list-style-type: none"> 1. Check for visible signs of damage (dents, tears, deformation) of the seat back on the collision side. 2. Check harness and connectors for damage, and terminals for deformities. 3. If damaged—REPLACE the front seat back assembly.
(LH or RH) side air bag (satellite) sensor	REPLACE the side air bag (satellite) sensor on the collision side with new nuts. (Repair the center pillar inner, etc. before installing new one if damaged.)	<ol style="list-style-type: none"> 1. Remove the side air bag (satellite) sensor on the collision side. Check harness connectors for damage, terminals for deformities, and harness for binding. 2. Check for visible signs of damage (dents, cracks, deformation) of the side air bag (satellite) sensor. 3. Install the side air bag (satellite) sensor to check fit. 4. If no damage is found, reinstall the side air bag (satellite) sensor with new nuts. 5. If damaged—REPLACE the side air bag (satellite) sensor with new nuts.
Diagnosis sensor unit	REPLACE the diagnosis sensor unit with the new bolts.	<ol style="list-style-type: none"> 1. Check case and bracket for dents, cracks or deformities. 2. Check connectors for damage, and terminals for deformities. 3. If no damage is found, reinstall the diagnosis sensor unit with new bolts and ground bolt. 4. If damaged—REPLACE the diagnosis sensor unit with new bolts and ground bolt.
Seat belt pre-tensioner assembly	<ol style="list-style-type: none"> 1. Check if the seat belt can be extended smoothly. If the seat belt cannot be extended smoothly, <ul style="list-style-type: none"> – Check for deformities of the center pillar inner. – If the center pillar inner has no damage, REPLACE the seat belt pre-tensioner assembly. 2. Remove the seat belt pre-tensioner assembly on the collision side. Check harness cover and connectors for damage, terminals for deformities, and harness for binding. 3. Check for visible signs of damage (dents, cracks, deformation) of the seat belt pre-tensioner assembly. 4. Check seat belt adjuster for damage. 5. If no damage is found, reinstall the seat belt pre-tensioner assembly. 6. If damaged—REPLACE the seat belt pre-tensioner assembly with new bolts. The seat belt pre-tensioner assembly must be deployed before disposing of it. 	
Seat (with front side air bag)	REPLACE front seat back assembly.	<ol style="list-style-type: none"> 1. Visually check the seat on the collision side. 2. Remove the seat on the collision side and check the following for damage and deformities. <ul style="list-style-type: none"> – Harness, connectors and terminals – Frame and recliner (for front and rear seat), and also adjuster and slides (for front seat) 3. If no damage is found, reinstall the seat. 4. If damaged—REPLACE the damaged seat parts using new bolts. If the front seat back is damaged, the front seat back assembly must be replaced.
Center inner pillar	<ol style="list-style-type: none"> 1. Check the center inner pillar on the collision side for damage (dents, cracks, deformation). 2. If damaged—REPAIR the center inner pillar. 	
Trim/headliner	<ol style="list-style-type: none"> 1. Check for visible signs of damage (dents, cracks, deformation) of the interior trim on the collision side. 2. If damaged—REPLACE the damaged trim parts. 	

A
B
C
D
E
F
G

SRS

I
J
K
L
M

COLLISION DIAGNOSIS
