

Edition: July 2005
 Revision: November 2006
 Publication No. SM6E-1L31U1

QUICK REFERENCE INDEX

**NISSAN
 ALTIMA
 MODEL L31 SERIES**

A GENERAL INFORMATION	GI General Information
B ENGINE	EM Engine Mechanical
	LU Engine Lubrication System
	CO Engine Cooling System
	EC Engine Control System
	FL Fuel System
	EX Exhaust System
	ACC Accelerator Control System
	CL Clutch
C TRANSMISSION/ TRANSAXLE	MT Manual Transaxle
	AT Automatic Transaxle
	FAX Front Axle
D DRIVELINE/AXLE	RAX Rear Axle
	FSU Front Suspension
E SUSPENSION	RSU Rear Suspension
	WT Road Wheels & Tires
	BR Brake System
F BRAKES	PB Parking Brake System
	BRC Brake Control System
	PS Power Steering System
G STEERING	
H RESTRAINTS	SB Seat Belts
	SRS Supplemental Restraint System (SRS)
	BL Body, Lock & Security System
I BODY	GW Glasses, Window System & Mirrors
	RF Roof
	EI Exterior & Interior
	IP Instrument Panel
	SE Seat
	ATC Automatic Air Conditioner
	MTC Manual Air Conditioner
J AIR CONDITIONER	SC Starting & Charging System
	LT Lighting System
	DI Driver Information System
	WW Wiper, Washer & Horn
	BCS Body Control System
	LAN LAN System
	AV Audio Visual & Telephone System
	ACS Auto Cruise Control System
	PG Power Supply, Ground & Circuit Elements
	MA Maintenance
	IDX Alphabetical Index
	L MAINTENANCE
M INDEX	

A

B

C

D

E

F

G

H

I

J

K

L

M

FOREWORD

This manual contains maintenance and repair procedures for the 2006 NISSAN ALTIMA.

In order to assure your safety and the efficient functioning of the vehicle, this manual should be read thoroughly. It is especially important that the PRECAUTIONS in the GI section be completely understood before starting any repair task.

All information in this manual is based on the latest product information at the time of publication. The right is reserved to make changes in specifications and methods at any time without notice.

IMPORTANT SAFETY NOTICE

The proper performance of service is essential for both the safety of the technician and the efficient functioning of the vehicle.

The service methods in this Service Manual are described in such a manner that the service may be performed safely and accurately. Service varies with the procedures used, the skills of the technician and the tools and parts available. Accordingly, anyone using service procedures, tools or parts which are not specifically recommended by NISSAN must first be completely satisfied that neither personal safety nor the vehicle's safety will be jeopardized by the service method selected.



NISSAN NORTH AMERICA, INC.
Technical Publications Department



PLEASE HELP MAKE THIS SERVICE MANUAL BETTER!

Your comments are important to NISSAN and will help us to improve our Service Manuals. Use this form to report any issues or comments you may have regarding our Service Manuals.

Please print this form and type or write your comments below. Mail or fax to:

Nissan North America, Inc.
Technical Service Information
39001 Sunrise Drive, P.O. Box 9200
Farmington Hills, MI USA 48331
FAX: (248) 488-3910

SERVICE MANUAL: Model: _____ **Year:** _____

PUBLICATION NO. (Refer to Quick Reference Index): _____

Please describe any Service Manual issues or problems in detail:

Page number(s) _____ *Note: Please include a copy of each page, marked with your comments.*

Are the trouble diagnosis procedures logical and easy to use? (circle your answer) YES NO

If no, what page number(s)? _____ *Note: Please include a copy of each page, marked with your comments.*

Please describe the issue or problem in detail: _____

Is the organization of the manual clear and easy to follow? (circle your answer) YES NO

Please comment: _____

What information should be included in NISSAN Service Manuals to better support you in servicing or repairing customer vehicles?

DATE: _____ YOUR NAME: _____ POSITION: _____

DEALER: _____ DEALER NO.: _____ ADDRESS: _____

CITY: _____ STATE/PROV./COUNTRY: _____ ZIP/POSTAL CODE: _____

QUICK REFERENCE CHART: ALTIMA (EQUIPPED WITH 2.5L QR25DE ENGINE)

2006

QUICK REFERENCE CHART: ALTIMA (EQUIPPED WITH 2.5L QR25DE ENGINE)

PFP:00000

Engine Tune-Up Data

ELS001PZ

Cylinder arrangement		In-line 4
Displacement cm ³ (in ³)		2,488 (151.82)
Bore and stroke mm (in)		89.0 x 100 (3.50 x 3.94)
Valve arrangement		DOHC
Firing order		1-3-4-2
Number of piston rings	Compression	2
	Oil	1
Compression ratio		9.5:1
Compression pressure kPa (kg/cm ² , psi) / 250 rpm	Standard	1,250 (12.8, 181.3)
	Minimum	1,060 (10.8, 153.7)
	Differential limit between cylinders	100 (1.0, 14)

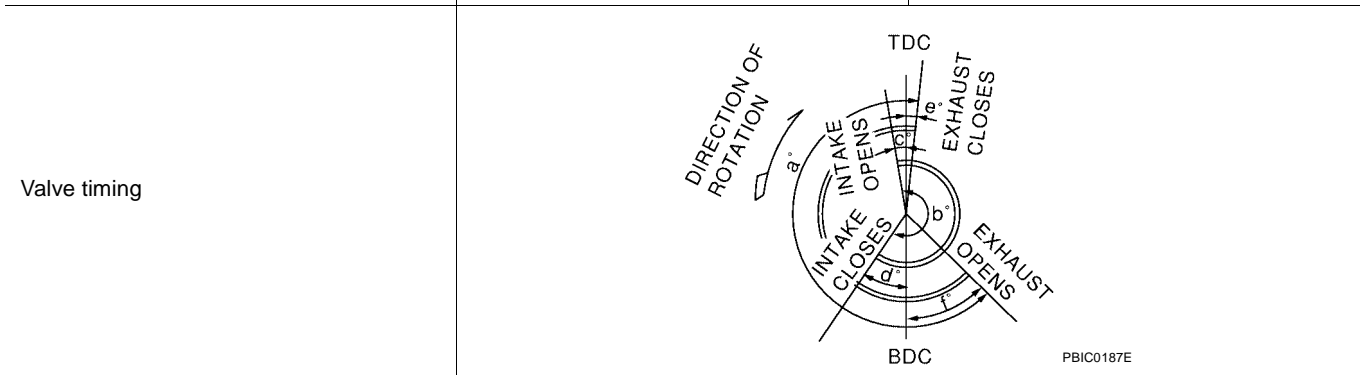

Unit: degree					
a	b	c	d	e	f
224°	244°	0°	64°	3°	41°

Drive Belt Deflection and Tension

Tension of drive belts	Auto adjustment by auto-tensioner
------------------------	-----------------------------------

Spark Plugs (Double Platinum Tipped)

Make		NGK
Type	Standard	PLFR5A-11
	Hot	PLFR4A-11
	Cold	PLFR6A-11
Plug gap (nominal)		1.1 mm (0.043 in)

QUICK REFERENCE CHART: ALTIMA (EQUIPPED WITH 2.5L QR25DE ENGINE)

2006

Front Wheel Alignment (Unladen*1)

ELS001Q0

Market		United States and Canada	Mexico	
Engine		QR25DE	QR25DE	
Model		Base/S	Base/S	
Tire size		215/60R16	215/60R16	
Camber Degree minute (decimal degree)	Minimum	-1°00' (-1.00°)	-0°40' (-0.67°)	
	Nominal	-0°15' (-0.25°)	0°05' (0.08°)	
	Maximum	0°30' (0.50°)	0°50' (0.83°)	
	Left and right difference	45' (0.75°) or less		
Caster Degree minute (decimal degree)	Minimum	2°05' (2.08°)	1°55' (1.92°)	
	Nominal	2°50' (2.83°)	2°40' (2.67°)	
	Maximum	3°35' (3.58°)	3°25' (3.42°)	
	Left and right difference	45' (0.75°) or less		
Kingpin inclination Degree minute (decimal degree)	Minimum	13°50' (13.83°)	13°10' (13.17°)	
	Nominal	14°35' (14.58°)	13°55' (13.93°)	
	Maximum	15°20' (15.33°)	14°40' (14.67°)	
Total toe-in	Distance (A – B) mm (in)	Minimum	-0.5 (-0.02)	0.0 (0.00)
		Nominal	0.5 (0.02)	1.0 (0.04)
		Maximum	1.5 (0.06)	2.0 (0.08)
	Angle (left, right) Degree minute (decimal degree)	Minimum	-0°04' (-0.07°)	-0°03' (-0.05°)
		Nominal	0°02' (0.03°)	0°03' (0.03°)
		Maximum	0°08' (0.13°)	0°09' (0.15°)
Wheel turning angle Full turn*2	Inside Degree minute (decimal degree)	Minimum	34°30' (34.5°)	
		Nominal	38°00' (38.0°)	
		Maximum	39°00' (39.0°)	
	Outside Degree minute (decimal degree)	Nominal	30°30' (30.5°)	

*1: Fuel, engine coolant and engine oil full. Spare tire, jack, hand tools and mats in designated positions.

*2: On power steering models, wheel turning force (at circumference of steering wheel) of 98 to 147 N (10 to 15 kg, 22 to 33 lb) with engine idle.

QUICK REFERENCE CHART: ALTIMA (EQUIPPED WITH 2.5L QR25DE ENGINE)

2006

Rear Wheel Alignment (Unladen*)

ELS001Q1

Market	United States and Canada	Mexico	
Engine	QR25DE	QR25DE	
Model	Base / S	Base / S	
Camber Degree minute (Decimal degree)	Minimum	-0° 04' (-0.07°)	-0° 30' (0.50°)
	Nominal	-0° 34' (-0.57°)	0° 0' (0°)
	Maximum	-0° 64' (-1.07°)	0° 30' (0.50°)

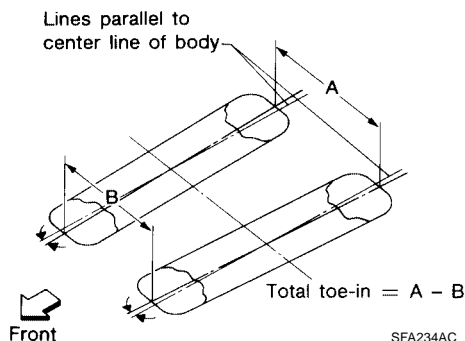

Total toe-in	Distance (A - B) mm (in)	Minimum	2.4 (0.09)	1.3 (0.05)
		Nominal	3.9 (0.15)	2.8 (0.11)
		Maximum	5.4 (0.21)	4.3 (0.17)
	Distance difference between RH and LH side mm (in)	Minimum	-2 (-0.08)	
		Nominal	0 (0)	
		Maximum	2 (0.08)	
	Angle (left plus right) Degree minute (decimal degree)	Minimum	0° 6' (0.10°)	0° 3' (0.05°)
		Nominal	0° 10' (0.17°)	0° 7' (0.12°)
		Maximum	0° 14' (0.23°)	0° 11' (0.18°)

*: Fuel, engine coolant and engine oil full. Spare tire, jack, hand tools and mats in designated positions.

Wheelarch Height (Unladen*)

EES0024U

Unit: mm (in)

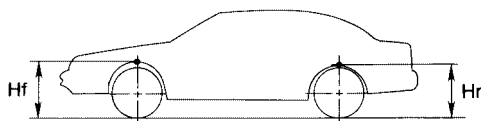

SFA818A

Market	United States and Canada	Mexico
Engine	QR25DE	QR25DE
Model	Base/S	Base/S
Tire size	215/60R16	215/60R16
Front (Hf)	722 (28.43)	742 (29.21)
Rear (Hr)	695 (27.36)	715 (28.15)

*: Fuel, engine coolant and engine oil full. Spare tire, jack, hand tools and mats in designated positions.

QUICK REFERENCE CHART: ALTIMA (EQUIPPED WITH 2.5L QR25DE ENGINE)

2006

Brake

ELS001Q2

Unit: mm (in)

Front brake	Brake model		CLZ25VD disc brake
	Cylinder bore diameter		57.2 (2.25)
	Pad Length × width × thickness		125.6 × 46 × 11 (4.94 × 1.81 × 0.43)
	Rotor outer diameter × thickness		297 × 24 (11.7 × 0.94)
Rear brake	Brake model		AD9A disc brake
	Cylinder bore diameter		34.9 (1.3740)
	Pad Length × width × thickness		89.1 × 39.5 × 10 (3.508 × 1.555 × 0.31)
	Rotor outer diameter × thickness		292 × 9 (11.5 × 0.35)
Master cylinder	Cylinder bore diameter		23.81 (15/16)
Control valve	Screw in type		30 × 0.4 (1.18 × 0.02)
Brake booster	Booster model		M215T
	Diaphragm diameter	Primary	230 (9.06)
		Secondary	205 (8.07)
Recommended brake fluid			Genuine NISSAN Super Heavy Duty Brake Fluid or equivalent DOT 3 (US FMVSS No. 16)

Disc Brake - Repair Limits

Unit: mm (in)

Brake model		CLZ25VD (Front)	AD9A (Rear)
Pad wear limit	Minimum thickness	2.0 (0.079)	1.5 (0.059)
	Maximum runout	0.07 (0.0028)	
Rotor repair limit	Minimum thickness	22.0 (0.866)	8.0 (0.31)
	Maximum thickness variation (at least 8 positions)	0.015 (0.0006)	

Brake Pedal

Unit: mm (in)

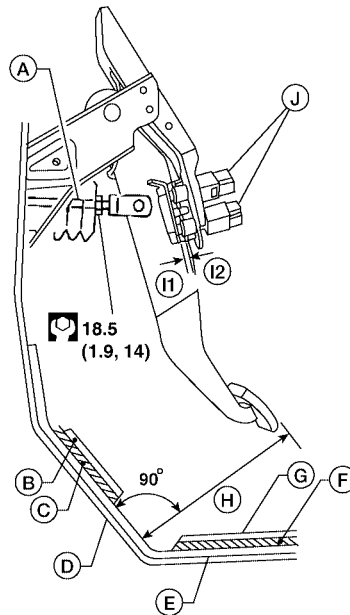

QUICK REFERENCE CHART: ALTIMA (EQUIPPED WITH 2.5L QR25DE ENGINE)

2006

Free height "H"	M/T	164.1 - 174.1 (6.46 - 6.85)
	A/T	173.1 - 183.1 (6.81 - 7.21)
Pedal height (with engine running, brake pedal force 490 N {50 kg-f, 110 lb-f} "H")	M/T	More than 84 (3.31)
	A/T	More than 90.3 (3.55)
Clearance "I1" or "I2" between pedal stopper and threaded end of stop lamp switch or ASCD switch		0.74 - 1.96 (0.0291 - 0.0772)
Pedal play		3 - 11 (0.12 - 0.43)

*: Measured from surface of dash reinforcement panel to surface of pedal pad

A: Input rod

B: Floor carpet

C: Dash Insulator

D: Floor Panel

E: Dash reinforcement panel

F: Dash insulator

G: Floor carpet

I1, I2: Gap

J: Stop lamp switch and ASCD switch

Refill Capacities

ELS001Q3

Description	Capacity (Approximate)			
	Liter	US measure	Imp measure	
Fuel	75.6	20 gal	16 5/8 gal	
Engine oil Drain and refill	With oil filter change	4.2	4 1/2 qt	3 3/4 qt
	Without oil filter change	4.0	4 1/4 qt	3 1/2 qt
Dry engine (engine overhaul)	4.6	4 7/8 qt	4 qt	
Cooling system	With reservoir at MAX level	7.6	2 gal	1 5/8 gal
Manual transaxle fluid (MTF)	2.2	2 3/8 qt	2 qt	
Automatic transaxle (4A/T) fluid (ATF)	9.2	9 3/4 qt	8 1/8 qt	
Power steering fluid (PSF)	1.0	2 1/8 pt	1 3/4 pt	
Air conditioning system refrigerant	0.50 ± 0.025 kg	1.10 ± 0.055 lb	1.10 ± 0.055 lb	
Air conditioning system oil	150 m ℓ	5.03 fl oz	5.01 fl oz	

QUICK REFERENCE CHART: ALTIMA (EQUIPPED WITH 3.5L VQ35DE ENGINE)

2006

QUICK REFERENCE CHART: ALTIMA (EQUIPPED WITH 3.5L VQ35DE ENGINE)

PFP:00000

Engine Tune-Up Data

ELS001Q4

Cylinder arrangement		V-6
Displacement cm^3 (in^3)		3,498 (213.45)
Bore and stroke mm (in)		95.5 x 81.4 (3.76 x 3.205)
Valve arrangement		DOHC
Firing order		1-2-3-4-5-6
Number of piston rings	Compression	2
	Oil	1
Number of main bearings		4
Compression ratio		10.0:1
Compression pressure kPa (kg/cm^2 , psi)/300 rpm	Standard	1,275 (13.0, 185)
	Minimum	981 (10.0, 142)
	Differential limit between cylinders	98 (1.0, 14)

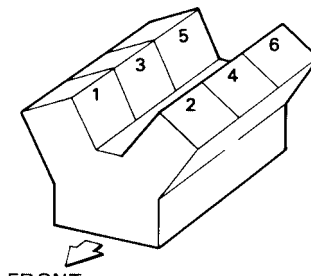
Cylinder number	 <p style="text-align: center;">FRONT</p> <p style="text-align: right; font-size: small;">SEM713A</p>
-----------------	--

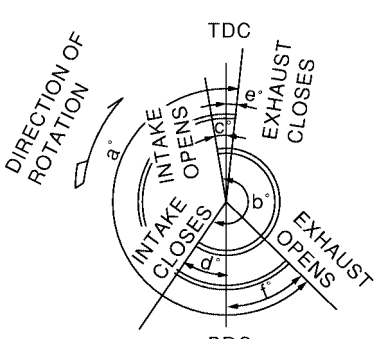
Valve timing (IVTC - OFF)	 <p style="text-align: right; font-size: small;">PBIC0187E</p>
---------------------------	--

Unit: degree					
a	b	c	d	e	f
240°	238°	- 6°	64°	8°	52°

Drive Belt Deflection and Tension

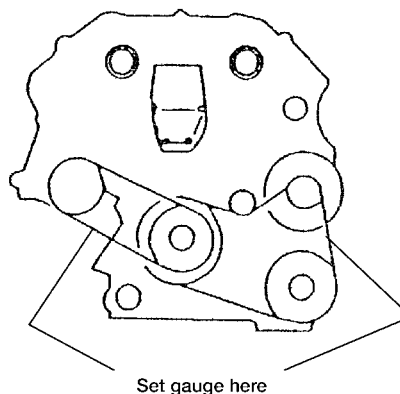
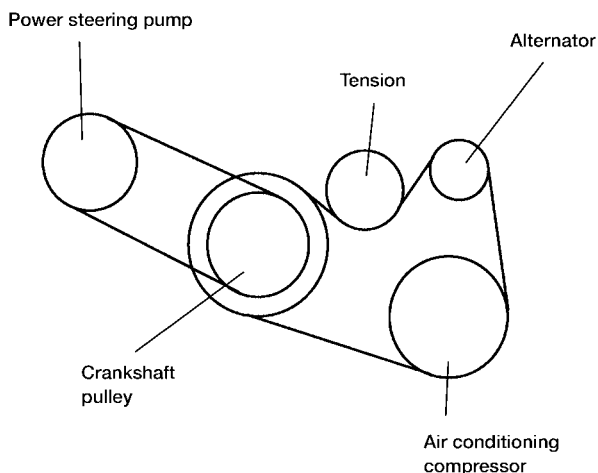

L8IA0076E

	Deflection adjustment			Unit: mm (in)	Tension adjustment*		Unit: N (kg, lb)
	Used belt		New belt	Used belt		New belt	
	Limit	After adjustment		Limit	After adjustment		
Alternator and air conditioning compressor	7 (0.28)	4.2 - 4.6 (0.17 - 0.18)	3.7 - 4.1 (0.15 - 0.16)	294 (30, 66)	730 - 818 (74.5 - 83.5, 164 - 184)	838 - 926 (85.5 - 94.5, 188 - 208)	
Power steering pump	11 (0.43)	7.3 - 8 (0.29 - 0.30)	6.5 - 7.2 (0.26 - 0.28)	196 (20, 44)	495 - 583 (50.5 - 59.5, 111 - 131)	603 - 691 (61.5 - 70.5, 135.6 - 155.4)	
Applied pushing force	98 N (10 kg, 22 lb)			—			

*: If belt tension gauge cannot be installed at check points shown, check drive belt tension at different location on the belt.

Spark Plugs (Double Platinum Tipped)

Make			NGK
Type	Standard	PLFR5A-11	
	Hot	PLFR4A-11	
	Cold	PLFR6A-11	
Gap (nominal)			1.1 mm (0.043 in)

QUICK REFERENCE CHART: ALTIMA (EQUIPPED WITH 3.5L VQ35DE ENGINE)

2006

Front Wheel Alignment (Unladen*1)

ELS001Q5

Market		United States and Canada			Mexico
		VQ35DE			VQ35DE
Engine		SL	SE	SE-R	SE
Model		215/60R16	215/55R17	225/45R18	215/55R17
Tire size					
Camber Degree minute (Decimal degree)	Minimum	-1°00' (-1.00°)			-0°40' (-0.67°)
	Nominal	-0°15' (-0.25°)			0°05' (0.08°)
	Maximum	0°30' (0.50°)			0°50' (0.83°)
	Left and right difference	45' (0.75°) or less			45' (0.75°) or less
Caster Degree minute (Decimal degree)	Minimum	2°05' (2.08°)			1°55' (1.92°)
	Nominal	2°50' (2.83°)			2°40' (2.67°)
	Maximum	3°35' (3.58°)			3°25' (3.42°)
	Left and right difference	45' (0.75°) or less			45' (0.75°) or less
Kingpin inclination Degree minute (Decimal degree)	Minimum	13°50' (13.83°)			13°10' (13.17°)
	Nominal	14°35' (14.58°)			13°55' (13.93°)
	Maximum	15°20' (15.33°)			14°40' (14.67°)
Total toe-in	Distance (A - B) mm (in)	Minimum	-0.5 (-0.02)		0.0 (0.00)
		Nominal	0.5 (0.02)		1.0 (0.04)
		Maximum	1.5 (0.06)		2.0 (0.08)
	Angle (left, right) Degree minute (Decimal degree)	Minimum	-0°04' (-0.07°)		-0°03' (-0.05°)
		Nominal	0°02' (0.03°)		0°03' (0.03°)
		Maximum	0°08' (0.13°)		0°09' (0.15°)
Wheel turning angle Full turn*2	Inside Degree minute (Decimal degree)	Minimum	32°00' (32.0°)	31°00' (31.0°)	32°00' (32.0°)
		Nominal	35°30' (35.5°)	34°30' (34.5°)	35°30' (35.5°)
		Maximum	36°30' (36.5°)	35°30' (35.5°)	36°30' (36.5°)
	Outside Degree minute (Decimal degree)	Nominal	29°00' (29.0°)	29°00' (29.0°)	29°00' (29.0°)

*1: Fuel, engine coolant and engine oil full. Spare tire, jack, hand tools and mats in designated positions.

*2: On power steering models, wheel turning force (at circumference of steering wheel) of 98 to 147 N (10 to 15 kg, 22 to 33 lb) with engine idle.

QUICK REFERENCE CHART: ALTIMA (EQUIPPED WITH 3.5L VQ35DE ENGINE)

2006

Rear Wheel Alignment (Unladen*)

ELS001Q6

Market		United States and Canada		Mexico
Engine		VQ35DE		VQ35DE
Model		SL / SE	SE-R	SE
Camber Degree minute (Decimal degree)	Minimum	-0° 2' (-0.03°)	-0° 13' (-0.22°)	-0° 30' (0.50°)
	Nominal	-0° 32' (-0.53°)	-0° 43' (-0.72°)	0° 0' (0°)
	Maximum	-1° 2' (-1.03°)	-1° 13' (-1.22°)	0° 30' (0.50°)

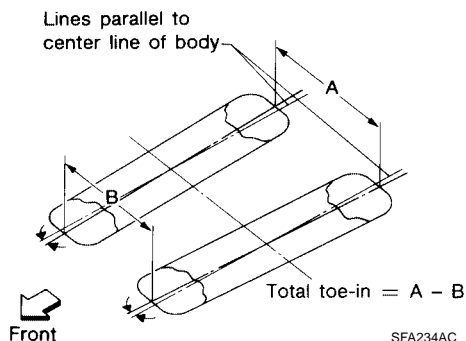

Total toe-in	Distance (A - B) mm (in)	Minimum	2.4 (0.09)	2.3 (0.09)	1.3 (0.05)
		Nominal	3.9 (0.15)	3.8 (0.15)	2.8 (0.11)
		Maximum	5.4 (0.21)	5.3 (0.21)	4.3 (0.17)
	Distance difference between RH and LH side mm (in)	Minimum	-2 (-0.08)		
		Nominal	0 (0)		
		Maximum	2 (0.08)		
	Angle (left plus right) Degree minute (decimal degree)	Minimum	0° 6' (0.10°)		0° 3' (0.05°)
		Nominal	0° 10' (0.17°)		0° 7' (0.12°)
		Maximum	0° 14' (0.23°)		0° 11' (0.18°)

*: Fuel, engine coolant and engine oil full. Spare tire, jack, hand tools and mats in designated positions.

Wheelarch Height (Unladen*)

EES001C1

Unit: mm (in)

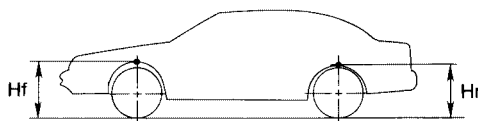

SFA818A

Market		United States and Canada			Mexico
Engine		VQ35DE			VQ35DE
Model		SL	SE	SE-R	SE
Tire size		215/60R16	215/55R17	225/45R18	215/55R17
Front (Hf)		717 (28.23)	722 (28.43)	721 (28.39)	741 (29.17)
Rear (Hr)		696 (27.40)	701 (27.60)	695 (27.36)	718 (28.27)

*: Fuel, engine coolant and engine oil full. Spare tire, jack, hand tools and mats in designated positions.

QUICK REFERENCE CHART: ALTIMA (EQUIPPED WITH 3.5L VQ35DE ENGINE)

2006

Brake

ELS001Q7

Unit: mm (in)

Front brake	Brake model		CLZ25VD disc brake	CLZ25VE disc brake
	Cylinder bore diameter		57.2 (2.25)	
	Pad Length × width × thickness		125.6 × 46 × 11 (4.94 × 1.81 × 0.43)	111.0 × 62.5 × 9.5 (4.37 × 2.46 × 0.37)
	Rotor outer diameter × thickness		297 × 24 (11.7 × 0.94)	320 × 28 (12.6 × 1.10)
Rear brake	Brake model		AD9A disc brake	
	Cylinder bore diameter		34.9 (1.3740)	
	Pad Length × width × thickness		89.1 × 39.5 × 10 (3.508 × 1.555 × 0.31)	
	Rotor outer diameter × thickness		292 × 9 (11.5 × 0.35)	
Master cylinder	Cylinder bore diameter		23.81 (15/16)	
Control valve	Screw in type		30 × 0.4 (1.18 × 0.02)	
Brake booster	Booster model		M215T	
	Diaphragm diameter	Primary	230 (9.06)	
		Secondary	205 (8.07)	
Recommended brake fluid			Genuine NISSAN Super Heavy Duty Brake Fluid or equivalent DOT 3 (US FMVSS No. 116)	

Disc Brake - Repair Limits

Unit: mm (in)

Brake model		CLZ25VD	CLZ25VE	AD9A
Pad wear limit	Minimum thickness	2.0 (0.079)		1.5 (0.059)
	Maximum runout	0.07 (0.0028)		
Rotor repair limit	Minimum thickness	22.0 (0.866)	26.0 (1.02)	8.0 (0.31)
	Maximum thickness variation (at least 8 positions)	0.015 (0.0006)		

QUICK REFERENCE CHART: ALTIMA (EQUIPPED WITH 3.5L VQ35DE ENGINE)

2006

Brake Pedal

Unit: mm (in)

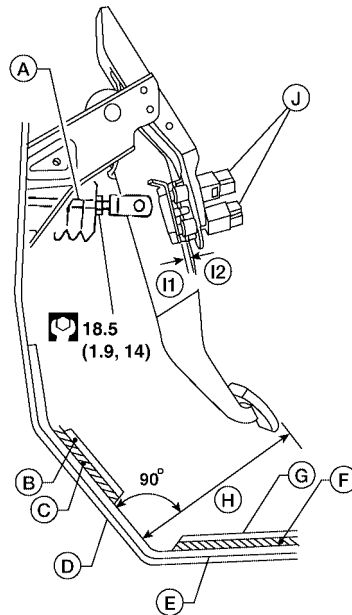

WFIA0423E

Free height "H"	M/T	164.1 - 174.1 (6.46 - 6.85)
	A/T	173.1 - 183.1 (6.81 - 7.21)
Pedal height (with engine running, brake pedal force 490 N {50 kg-f, 110 lb-f} "H")	M/T	More than 84 (3.31)
	A/T	More than 90.3 (3.55)
Clearance "I1" or "I2" between pedal stopper and threaded end of stop lamp switch or ASCD switch		0.74 - 1.96 (0.0291 - 0.0772)
Pedal play		3 - 11 (0.12 - 0.43)

*: Measured from surface of dash reinforcement panel to surface of pedal pad

A: Input rod

B: Floor carpet

C: Dash Insulator

D: Floor Panel

E: Dash reinforcement panel

F: Dash insulator

G: Floor carpet

I1, I2: Gap

J: Stop lamp switch and ASCD switch

QUICK REFERENCE CHART: ALTIMA (EQUIPPED WITH 3.5L VQ35DE ENGINE)

2006

Refill Capacities

ELS001Q8

Description		Capacity (Approximate)		
		Liter	US measure	Imp measure
Fuel		75.6	20 gal	16 5/8 gal
Engine oil	With oil filter change	4.2	4 1/2 qt	3 3/4 qt
Drain and refill	Without oil filter change	4.0	4 1/4 qt	3 1/2 qt
Dry engine (engine overhaul)		4.6	4 7/8 qt	4 qt
Cooling system	With reservoir at MAX level	8.2	2 1/8 gal	1 3/4 gal
Manual transaxle fluid (MTF)		2.2	2 3/8 qt	2 qt
Automatic transaxle (5A/T) fluid (ATF)		7.3	7 3/4 qt	6 3/8 qt
Power steering fluid (PSF)		1.0	2 1/8 pt	1 3/4 pt
Air conditioning system refrigerant		0.50 ± 0.025 kg	1.10 ± 0.055 lb	1.10 ± 0.055 lb
Air conditioning system oil		150 m ℓ	5.03 fl oz	5.01 fl oz