

Edition: January 2007

Revision: May 2007

Publication No. SM7E-1H32U1

NISSAN ALTIMA HYBRID MODEL HL32 SERIES



© 2007

NISSAN NORTH
AMERICA, INC.

All rights reserved. No part of this Service Manual may be reproduced or stored in a retrieval system, or transmitted in any form, or by any means, electronic, mechanical, photo-copying, recording or otherwise, without the prior written permission of Nissan North America, Inc.

QUICK REFERENCE INDEX

A GENERAL INFORMATION	GI General Information
B ENGINE	EM Engine Mechanical
	LU Engine Lubrication System
	CO Engine Cooling System
	EC Engine Control System
	FL Fuel System
	EX Exhaust System
	STR Starting System
	ACC Accelerator Control System
	HBC Hybrid Control System
	HBB Hybrid Battery System
HBR Hybrid Brake System	
C HYBRID	CL Clutch System
	TM Transaxle & Transmission
	DLN Driveline
	FAX Front Axle
	RAX Rear Axle
D TRANSMISSION & DRIVE-LINE	FSU Front Suspension
	RSU Rear Suspension
	SCS Suspension Control System
	WT Road Wheels & Tires
	BR Brake System
E SUSPENSION	PB Parking Brake System
	BRC Brake Control System
	ST Steering System
F BRAKES	STC Steering Control System
	SB Seat Belt
	SBC Seat Belt Control System
G STEERING	SRS SRS Airbag
	SRC SRS Airbag Control System
	VTL Ventilation System
H RESTRAINTS	HA Heater & Air Conditioning System
	HAC Heater & Air Conditioning Control System
	INT Interior
I VENTILATION, HEATER & AIR CONDITIONER	IP Instrument Panel
	SE Seat
	ADP Automatic Drive Positioner
	DLK Door & Lock
	SEC Security Control System
J BODY INTERIOR	GW Glass & Window System
	PWC Power Window Control System
	RF Roof
	EXT Exterior
	BRM Body Repair Manual
	MIR Mirrors
	EXL Exterior Lighting System
	INL Interior Lighting System
	WW Wiper & Washer
	DEF Defogger
K BODY EXTERIOR, DOORS, ROOF & VEHICLE SECURITY	HRN Horn
	PWO Power Outlet
	BCS Body Control System
	LAN LAN System
	PCS Power Control System
	CHG Charging System
	PG Power Supply, Ground & Circuit Elements
	MWI Meter, Warning Lamp & Indicator
	WCS Warning Chime System
	SN Sonar System
AV Audio, Visual & Navigation System	
L DRIVER CONTROLS	CCS Cruise Control System
	MA Maintenance
M ELECTRICAL & POWER CONTROL	
N DRIVER INFORMATION & MULTIMEDIA	
O CRUISE CONTROL	
P MAINTENANCE	

A
B
C
D
E
F
G
H
I
J
K
L
M
N
O
P

FOREWORD

This manual contains maintenance and repair procedure for the 2007 NISSAN ALTIMA HYBRID.

In order to assure your safety and the efficient functioning of the vehicle, this manual should be read thoroughly. It is especially important that the PRECAUTIONS in the GI section be completely understood before starting any repair task.

All information in this manual is based on the latest product information at the time of publication. The right is reserved to make changes in specifications and methods at any time without notice.

IMPORTANT SAFETY NOTICE

The proper performance of service is essential for both the safety of the technician and the efficient functioning of the vehicle.

The service methods in this Service Manual are described in such a manner that the service may be performed safely and accurately. Service varies with the procedures used, the skills of the technician and the tools and parts available. Accordingly, anyone using service procedures, tools or parts which are not specifically recommended by NISSAN must first be completely satisfied that neither personal safety nor the vehicle's safety will be jeopardized by the service method selected.



NISSAN NORTH AMERICA, INC.
Technical Publications Department



PLEASE HELP MAKE THIS SERVICE MANUAL BETTER!

Your comments are important to NISSAN and will help us to improve our Service Manuals.
Use this form to report any issues or comments you may have regarding our Service Manuals.
Please print this form and type or write your comments below. Mail or fax to:

Nissan North America, Inc.
Technical Service Information
39001 Sunrise Drive, P.O. Box 9200
Farmington Hills, MI USA 48331
FAX: (248) 488-3910

SERVICE MANUAL: Model: _____ **Year:** _____

PUBLICATION NO. (Refer to Quick Reference Index): _____

Please describe any Service Manual issues or problems in detail:

Page number(s) _____ *Note: Please include a copy of each page, marked with your comments.*

Are the trouble diagnosis procedures logical and easy to use? (circle your answer) YES NO

If no, what page number(s)? _____ *Note: Please include a copy of each page, marked with your comments.*

Please describe the issue or problem in detail: _____

Is the organization of the manual clear and easy to follow? (circle your answer) YES NO

Please comment: _____

What information should be included in NISSAN Service Manuals to better support you in servicing or repairing customer vehicles?

DATE: _____ YOUR NAME: _____ POSITION: _____

DEALER: _____ DEALER NO.: _____ ADDRESS: _____

CITY: _____ STATE/PROV./COUNTRY: _____ ZIP/POSTAL CODE: _____

QUICK REFERENCE CHART: ALTIMA HYBRID

Engine Tune-Up Data

INFOID:000000001303700

GENERAL SPECIFICATIONS

Cylinder arrangement		In-line 4
Displacement cm ³ (in ³)		2,488 (151.82)
Bore and stroke mm (in)		89.0 x 100 (3.50 x 3.94)
Valve arrangement		DOHC
Firing order		1-3-4-2
Number of piston rings	Compression	2
	Oil	1
Compression ratio		9.5:1
Compression pressure (kg/cm ² , psi) / 250 rpm	Standard	1,250 (12.8, 181.3)
	Minimum	1,060 (10.8, 153.7)
	Differential limit between cylinders	100 (1.0, 14)

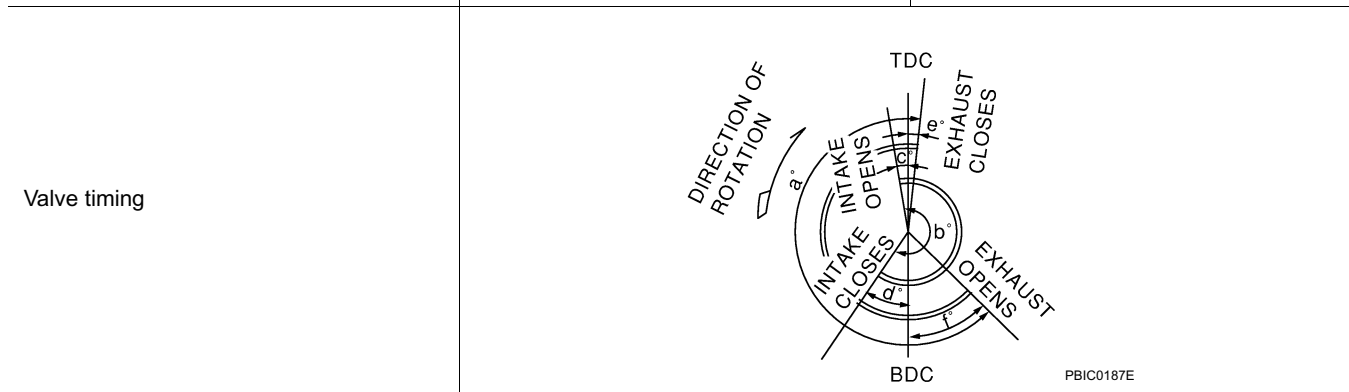

Unit: degree

a	b	c	d	e	f
220°	232°	-41°	93°	10°	30°

DRIVE BELTS

Tension of drive belts	Auto adjustment by auto tensioner
------------------------	-----------------------------------

SPARK PLUG

Unit: mm (in)

Make	NGK	
Type	Standard	DILKAR6A-11
Gap (nominal)	1.1 (0.043)	

Front Wheel Alignment*

Camber* Decimal degree	LH	Minimum	- 1.15°
		Nominal	- 0.40°
		Maximum	0.35°
	RH	Minimum	- 1.40°
		Nominal	- 0.65°
		Maximum	0.10°
Left and right difference			0.55°
Caster* Decimal degree	Minimum	4.25°	
	Nominal	5.00°	
	Maximum	5.75°	
	Left and right difference	0.25°	
Kingpin offset* Decimal degree	Minimum	11.80°	
	Nominal	12.55°	
	Maximum	13.30°	

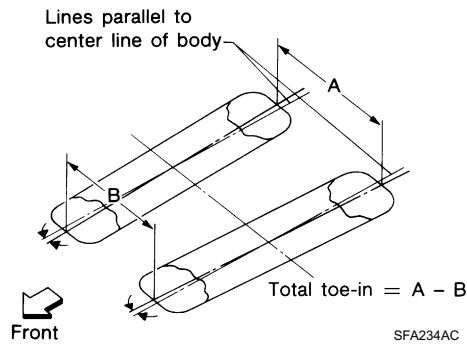

Total toe-in*	Distance (A - B)	Minimum	0 mm (0 in)
		Nominal	1 mm (0.04 in)
		Maximum	2 mm (0.08 in)

*:Fuel, radiator coolant and engine oil full. Spare tire, jack, hand tools and mats in designated positions.

Rear Wheel Alignment *

Camber Degree minute (Decimal degree)	Minimum	-1° 12' (-1.20°)
	Nominal	-0° 42' (-0.70°)
	Maximum	-0° 12' (-1.20°)

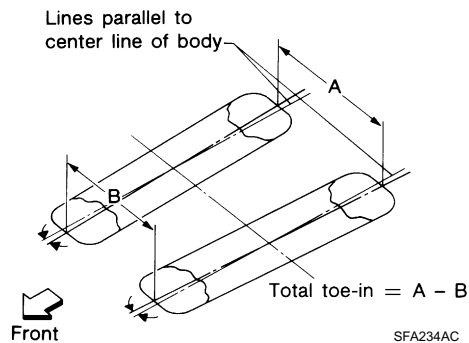

QUICK REFERENCE CHART: ALTIMA HYBRID

2007

Total toe-in	Distance (A – B) mm (in)	Minimum	1.1 (0.04)
		Nominal	2.7 (0.11)
		Maximum	4.3 (0.17)
	Distance difference between RH and LH side mm (in)	Minimum	-2 (-0.08)
		Nominal	0 (0)
		Maximum	2 (0.08)
	Angle (left plus right) Degree minute (decimal degree)	Minimum	0° 3' (0.05°)
		Nominal	0° 7' (0.12°)
		Maximum	0° 11' (0.18°)

*: Fuel, engine coolant and engine oil full. Spare tire, jack, hand tools and mats in designated positions.

Wheel Height

Unit: mm (in)

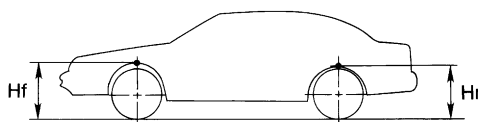

SFA818A

Destination	USA	Canada
Tire size	215/60R16	215/60R16
Front (Hf)*	727 (28.62)	727 (28.62)
Rear (Hr)*	718 (28.27)	719 (28.31)

*: Fuel, engine coolant and engine oil full. Spare tire, jack, hand tools and mats in designated positions.

Brake - General Specifications

Unit: mm (in)

Front brake	Cylinder bore diameter (each)	57.2 (2.25)
	Pad length × width × thickness	132 × 50 × 11 (5.20 × 1.969 × 0.433)
	Rotor outer diameter × thickness	296 × 26 (11.65 × 1.024)
Rear brake	Cylinder bore diameter	34.93 (1.375)
	Pad length × width × thickness	83.0 × 31.9 × 8.5 (3.268 × 1.256 × 0.335)
	Rotor outer diameter × thickness	292 × 9 (11.50 × 0.35)
Recommended brake fluid		DOT 3

Brake Pedal

Brake pedal height (from dash lower panel top surface)	189.7 - 203.7 mm (7.47 - 8.02 in)
Depressed pedal height [under a force of 490 N (50 kg-f, 110 lb-f) with engine running]	90 mm (3.54 in) or more
Clearance between stopper rubber and threaded end of the stop lamp switch and brake switch	0.74 - 1.96 mm (0.0291 - 0.0772 in)
Pedal play	3 - 11 mm (0.12 - 0.43 in)

QUICK REFERENCE CHART: ALTIMA HYBRID

2007

Front Disc Brake

Brake pad	Standard thickness (new)	11.0 mm (0.433 in)
	Repair limit thickness	2.0 mm (0.079 in)
Disc rotor	Standard thickness (new)	26.0 mm (1.024 in)
	Repair limit thickness	24.0 mm (0.945 in)
	Thickness variation (measured at 8 positions)	0.015 mm (0.0006 in)
	Maximum runout (with it attached to the vehicle)	0.035 mm (0.0014 in)

Rear Disc Brake

Brake pad	Standard thickness (new)	8.5 mm (0.335 in)
	Repair limit thickness	1.0 mm (0.039 in)
Disc rotor	Standard thickness (new)	9.0 mm (0.354 in)
	Repair limit thickness	8.0 mm (0.315 in)
	Thickness variation (measured at 8 positions)	0.015 mm (0.0006 in)
	Maximum runout (with it attached to the vehicle)	0.05 mm (0.002 in)

Fluids and Lubricants

Description	Capacity (Approximate)			
	US measure	Imp measure	Liter	
Fuel	20 gal	16-5/8 gal	75.6	
Engine oil Drain and refill	With oil filter change	4-7/8 qt	4 qt	4.6
	Without oil filter change	4-1/2 qt	3-3/4 qt	4.3
Dry engine (Overhaul)	5-3/4 qt	4-3/4 qt	5.4	
Engine cooling system with reservoir tank	2 gal	1-3/4 gal	7.7	
Inverter coolant with reservoir tank	3/4 gal	7/8 gal	3.2	
HEV transaxle fluid	4-3/8 qt	3-5/8 qt	4.1	
Brake fluid	—	—	—	
Brake grease	—	—	—	
Brake pad plate grease	—	—	—	
HEV transaxle grease	—	—	—	
Multi-purpose grease	—	—	—	
Air conditioning system refrigerant	1.10 ± 0.055 lb	0.50 ± 0.025 kg	0.50 ± 0.025 kg	
Air conditioning system oil	4.06 fl oz	4.22 fl oz	120 m ℓ	