

SECTION **SR**
SRS AIRBAG

A
B
C
D
E
F
G
SR
I
J
K
L
M
N
O
P

CONTENTS

PRECAUTION	2	Removal and Installation	9
PRECAUTIONS	2	SIDE CURTAIN AIR BAG MODULE	11
Precaution for Supplemental Restraint System (SRS) "AIR BAG" and "SEAT BELT PRE-TENSIONER"	2	Exploded View	11
Service	2	Removal and Installation	11
Occupant Classification System	2	CRASH ZONE SENSOR	13
PREPARATION	3	Exploded View	13
PREPARATION	3	Removal and Installation	13
Special Service Tool	3	SIDE AIR BAG (SATELLITE) SENSOR	14
Commercial Service Tools	3	Exploded View	14
ON-VEHICLE REPAIR	4	Removal and Installation	14
DRIVER AIR BAG MODULE	4	DIAGNOSIS SENSOR UNIT	15
Exploded View	4	Exploded View	15
Removal and Installation	4	Removal and Installation	15
SPIRAL CABLE	7	OCCUPANT CLASSIFICATION SYSTEM CONTROL UNIT	17
Removal and Installation	7	Removal and Installation	17
FRONT PASSENGER AIR BAG MODULE	9	COLLISION DIAGNOSIS	18
		For Frontal Collision	18
		For Side and Rollover Collision	20

PRECAUTIONS

< PRECAUTION >

PRECAUTION

PRECAUTIONS

Precaution for Supplemental Restraint System (SRS) "AIR BAG" and "SEAT BELT PRE-TENSIONER"

INFOID:000000005809571

The Supplemental Restraint System such as "AIR BAG" and "SEAT BELT PRE-TENSIONER", used along with a front seat belt, helps to reduce the risk or severity of injury to the driver and front passenger for certain types of collision. This system includes seat belt switch inputs and dual stage front air bag modules. The SRS system uses the seat belt switches to determine the front air bag deployment, and may only deploy one front air bag, depending on the severity of a collision and whether the front occupants are belted or unbelted. Information necessary to service the system safely is included in the SR and SB section of this Service Manual.

WARNING:

- To avoid rendering the SRS inoperative, which could increase the risk of personal injury or death in the event of a collision which would result in air bag inflation, all maintenance must be performed by an authorized NISSAN/INFINITI dealer.
- Improper maintenance, including incorrect removal and installation of the SRS, can lead to personal injury caused by unintentional activation of the system. For removal of Spiral Cable and Air Bag Module, see the SR section.
- Do not use electrical test equipment on any circuit related to the SRS unless instructed to in this Service Manual. SRS wiring harnesses can be identified by yellow and/or orange harnesses or harness connectors.

PRECAUTIONS WHEN USING POWER TOOLS (AIR OR ELECTRIC) AND HAMMERS

WARNING:

- When working near the Airbag Diagnosis Sensor Unit or other Airbag System sensors with the Ignition ON or engine running, DO NOT use air or electric power tools or strike near the sensor(s) with a hammer. Heavy vibration could activate the sensor(s) and deploy the air bag(s), possibly causing serious injury.
- When using air or electric power tools or hammers, always switch the Ignition OFF, disconnect the battery, and wait at least 3 minutes before performing any service.

Service

INFOID:000000005440347

- Do not use electrical test equipment to check SRS circuits unless instructed to in this Service Manual.
- Before servicing the SRS, turn ignition switch OFF, disconnect both 12-volt battery terminals and wait at least 3 minutes.
For approximately 3 minutes after the 12-volt battery terminals are removed, it is still possible for the air bag and seat belt pre-tensioner to deploy. Therefore, do not work on any SRS connectors or wires until at least 3 minutes have passed.
- Diagnosis sensor unit must always be installed with their arrow marks "⇐" pointing towards the front of the vehicle for proper operation. Also check diagnosis sensor unit for cracks, deformities or rust before installation and replace as required.
- The spiral cable must be aligned with the neutral position since its rotations are limited. Do not turn steering wheel and column after removal of steering gear.
- Handle air bag module carefully. Always place driver and front passenger air bag modules with the pad side facing upward and seat mounted front side air bag module standing with the stud bolt side facing down.
- Conduct self-diagnosis to check entire SRS for proper function after replacing any components.
- After air bag inflates, the front instrument panel assembly should be replaced if damaged.
- Always replace instrument panel pad following front passenger air bag deployment.

Occupant Classification System

INFOID:000000005440348

- Replace occupant classification system control unit and passenger front seat cushion as an assembly. Refer to [SE-29. "PASSENGER SIDE : Disassembly"](#).

PREPARATION

< PREPARATION >

PREPARATION

PREPARATION

Special Service Tool

INFOID:000000005440349

The actual shapes of Kent-Moore tools may differ from those of special service tools illustrated here.

Tool number (Kent-Moore No.) Tool name	Description
— (J-44615) Air bag lock master key set	Removing and installing air bag lock



Commercial Service Tools

INFOID:000000005440350

Tool name	Description
Power tools	Loosening bolts, nuts and screws



A
B
C
D
E
F
G
I
J
K
L
M
N
O
P

SR

DRIVER AIR BAG MODULE

< ON-VEHICLE REPAIR >

ON-VEHICLE REPAIR

DRIVER AIR BAG MODULE

Exploded View

INFOID:000000005440351

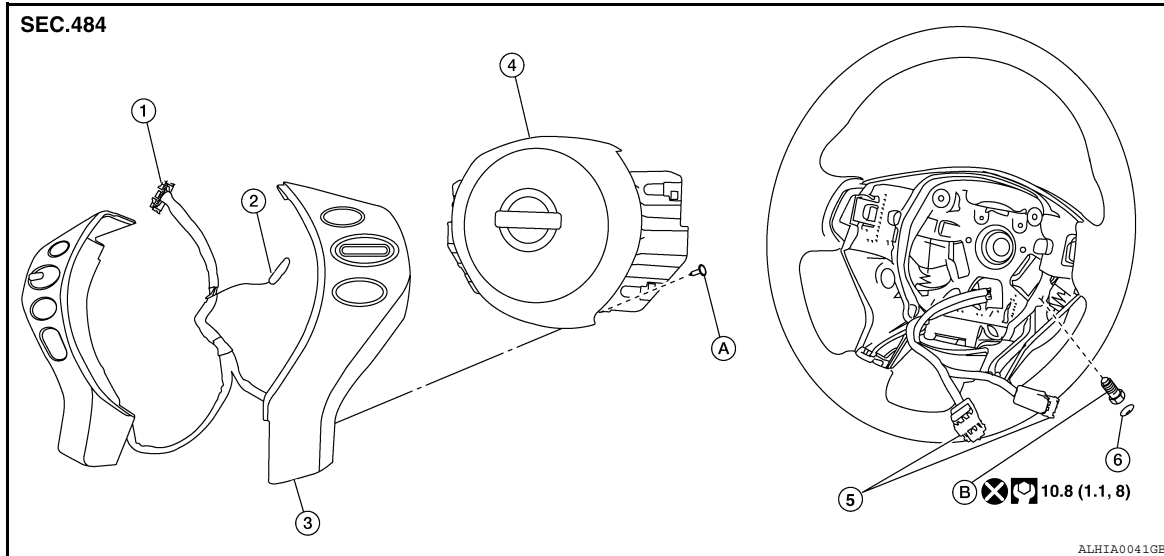

- | | | |
|------------------------------|---------------------------------------|----------------------|
| 1. Steering switch connector | 2. Steering switch ground connector | 3. Steering switches |
| 4. Driver air bag module | 5. Driver air bag module connectors | 6. Side lid (RH/LH) |
| A. Steering switch screw | B. Driver air bag module bolt (RH/LH) | |

Removal and Installation

INFOID:000000005440352

REMOVAL

CAUTION:

- Before servicing, turn ignition switch OFF, disconnect both 12-volt battery terminals and wait at least 3 minutes.
- Do not use air tools or electric tools for servicing.
- Always work from the side of air bag module. Do not work from the front of it.
- Always place air bag module with pad side facing upward.
- Do not use old bolts after removal; replace with new bolts.
- Do not cause impact to the air bag module by dropping etc. Replace the air bag module if it has been dropped or sustained an impact.

1. Disconnect the negative and positive 12-volt battery terminals, then wait at least 3 minutes.
2. Remove side lids, then remove the driver air bag module bolts (RH/LH).
3. Raise driver air bag module away from the steering wheel, then disconnect the steering switch.
4. Disconnect the driver air bag module connectors, then remove driver air bag module from steering wheel.
 - For installing/removing direct-connect SRS connectors, refer to [SRC-9. "Direct-connect SRS Component Connectors"](#).

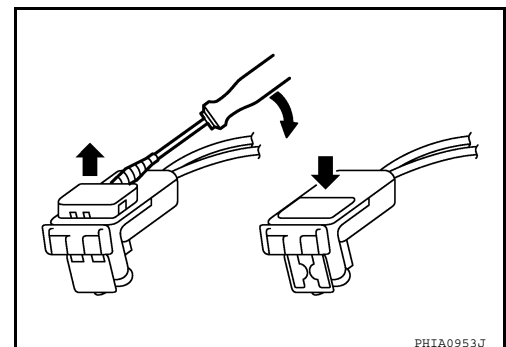

DRIVER AIR BAG MODULE

< ON-VEHICLE REPAIR >

5. Disconnect the steering switch ground connector (1), then release the harness (2) from the clips.
6. Remove the steering switch screws (RH/LH) (A), then remove the steering switches from driver air bag module.

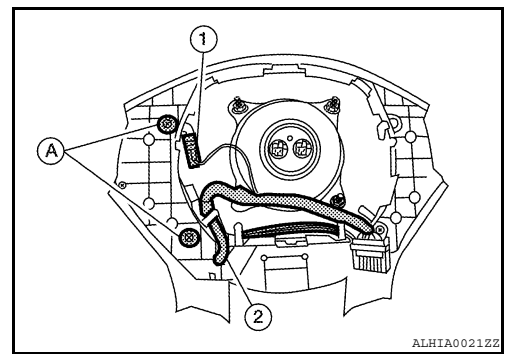

INSTALLATION

1. Attach steering switches (RH/LH) to driver air bag module.
2. Place the driver air bag module near the steering wheel and attach connectors (A) as shown.
3. Lift the driver air bag module while rotating counterclockwise into position over steering wheel.

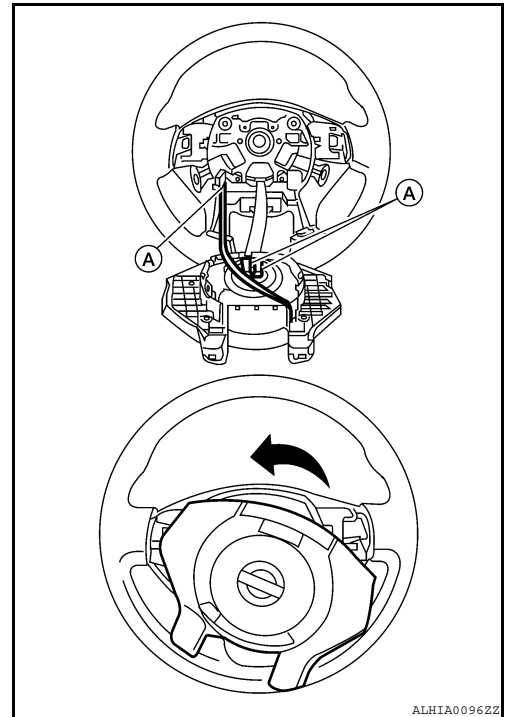

A
B
C
D
E
F
G
SR
I
J
K
L
M
N
O
P

DRIVER AIR BAG MODULE

< ON-VEHICLE REPAIR >

4. Pulling down on the steering switch harness, install the air bag module into the steering wheel.
 - Make sure that the steering switch harness is routed below the center of the air bag module inflator (1) as shown (B), and is not routed so it is pinched between the driver air bag module inflator (1) and steering column shaft threads as shown (A).

CAUTION:

Make sure the steering switch harness is correctly routed below the center of the driver air bag module inflator (1) as shown (B), and NOT incorrectly routed across the driver air bag module inflator as shown (A).

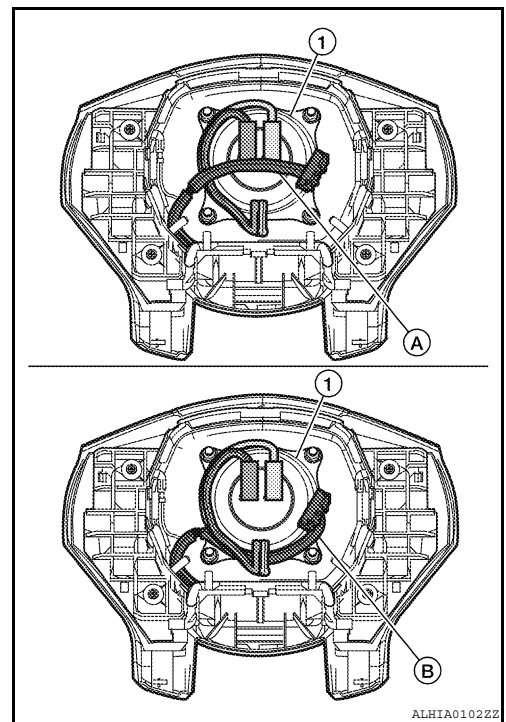

5. Install the remaining components in the reverse order of removal.

CAUTION:

- Be careful not to damage or pinch the harness while installing.
- Tighten the driver air bag module bolts after centering the holes between the driver air bag module and the steering wheel horn contact bracket. If the holes are misaligned, the bolt threads may become damaged and the module will not install securely.
- After the work is completed, make sure no system malfunction is detected by air bag warning lamp.
- In case a malfunction is detected by the air bag warning lamp, reset by the self-diagnosis function and delete the memory by CONSULT-III.
- If a malfunction is still detected after the above operation, perform self-diagnosis to repair malfunctions. Refer to [SRC-12, "SRS Operation Check"](#).

SPIRAL CABLE

< ON-VEHICLE REPAIR >

SPIRAL CABLE

Removal and Installation

INFOID:000000005440353

REMOVAL

CAUTION:

- Before servicing, turn ignition switch OFF, disconnect both 12-volt battery terminals and wait at least 3 minutes.
 - Do not use air tools or electric tools for servicing.
 - Do not disassemble the spiral cable.
 - Do not allow oil, grease, detergent or water to come in contact with the spiral cable.
 - Do not cause impact to the spiral cable by dropping etc. Replace the spiral cable if it has been dropped or sustained an impact.
 - With the steering linkage disconnected, the cable may snap by turning the steering wheel beyond the limited number of turns. The spiral cable can be turned counterclockwise about 2 turns from the neutral position.
1. Disconnect the 12-volt battery negative and positive terminals, then wait at least 3 minutes.
 2. Remove the steering wheel. Refer to [ST-7, "Removal and Installation"](#).
 3. Remove the column cover. Refer to [IP-10, "Exploded View"](#).
 4. Disconnect the harness connectors (2) from spiral cable (1).

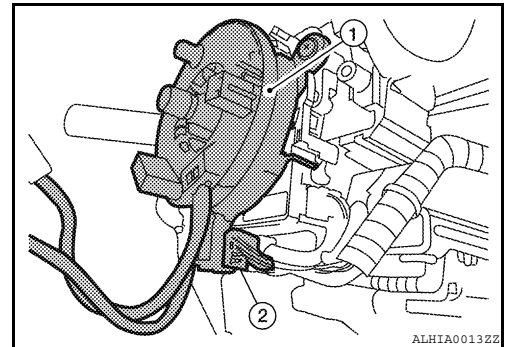

5. Rotate the spiral cable slightly so the locating pin (2) is positioned at the top.
 - Locating hole (1)
 - Alignment arrows (B)
6. Remove the lighting and turn signal switch, and wiper and washer switch.
7. Remove the screws (A), then remove spiral cable from the steering column.

CAUTION:

Do not turn the spiral cable quickly or beyond the limit number of turns (approximately 2 turns from the neutral position), this may cause the cable to snap.

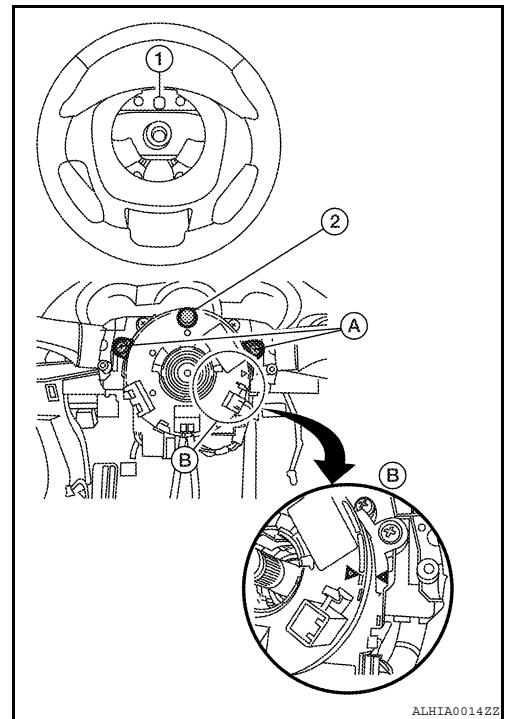

8. Remove the steering angle sensor. Refer to [BRC-202, "Removal and Installation"](#).

INSTALLATION

Installation is in the reverse order of removal.

A
B
C
D
E
F
G
SR
I
J
K
L
M
N
O
P

SPIRAL CABLE

< ON-VEHICLE REPAIR >

- Set the spiral cable neutral position.
- Slowly turn the spiral cable clockwise to the end position.
- Next, turn it counterclockwise (approximately 2 turns) then stop turning at the point when the alignment arrows (B) are directly across from each other.
- Rotate the spiral cable slightly so the locating pin (2) is positioned at the top.

NOTE:

A service part is installed in the neutral position with a stopper clip in place and should not be adjusted after the stopper clip is removed.

- Align the locating hole (1) at the top of the steering wheel with the locating pin (2) of the spiral cable during installation.
- Reset steering angle sensor. Refer to [BRC-9, "PERFORM ZERO POINT OF STEERING ANGLE SENSOR : Special Repair Requirement"](#).

CAUTION:

- The spiral cable may snap by steering operation if the cable is installed in an improper position.
- Do not turn the spiral cable quickly or beyond the limit number of turns. (This can cause the cable to snap.)
- After the work is completed, make sure no system malfunction is detected by air bag warning lamp.
- In case a malfunction is detected by the air bag warning lamp, reset with the self-diagnosis function and delete the memory with CONSULT-III.
- If a malfunction is still detected after the above operation, perform self-diagnosis to repair malfunctions. Refer to [SRC-12, "SRS Operation Check"](#).

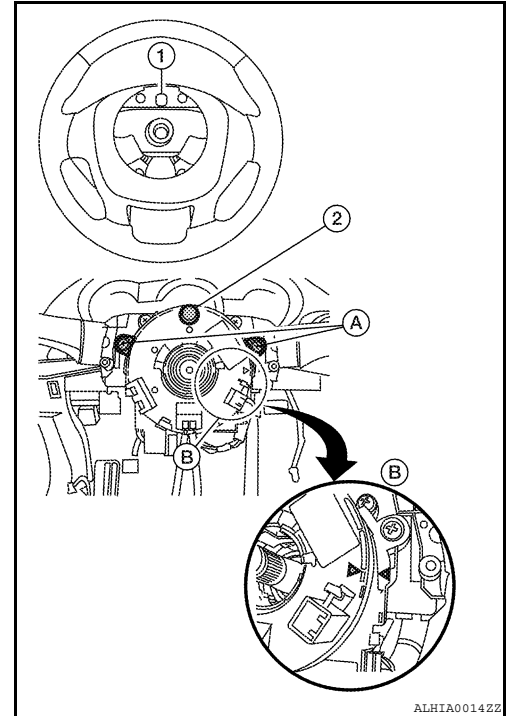

FRONT PASSENGER AIR BAG MODULE

< ON-VEHICLE REPAIR >

FRONT PASSENGER AIR BAG MODULE

Removal and Installation

INFOID:000000005440354

REMOVAL

CAUTION:

- Before servicing, turn ignition switch OFF, disconnect both 12-volt battery terminals and wait at least 3 minutes.
- Do not use air tools or electric tools for servicing.
- Always work from the side of air bag module. Do not work from the front of it.
- Always place air bag module with pad side facing upward.
- Do not use old bolts after removal; replace with new bolts.
- Do not cause impact to the air bag module by dropping etc. Replace the air bag module if it has been dropped or sustained an impact.

1. Disconnect the 12-volt battery negative and positive terminals, then wait at least 3 minutes.
2. Remove the glove box assembly. Refer to [IP-10, "Exploded View"](#).
3. Disconnect both front passenger air bag module connectors (1).

- ⇐ Vehicle front.

NOTE:

The figure shows installed condition of the front passenger air bag module. (Lower view of the module installed, and with the glove box removed.)

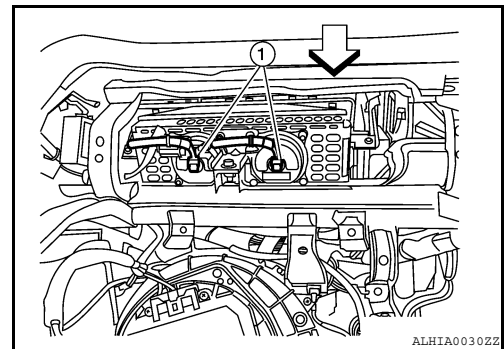

4. Remove front passenger air bag module bolt (A).

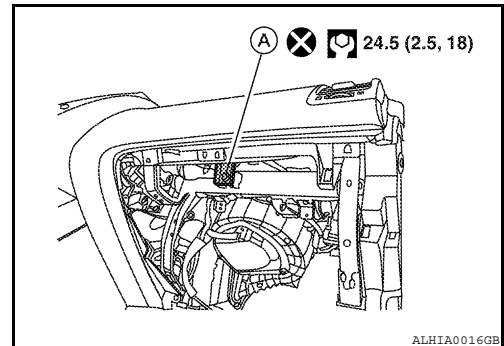

5. Remove the remaining instrument panel from the vehicle. Refer to [IP-11, "Removal and Installation"](#).
6. Remove the front passenger air bag module screws (A).
⇐ Vehicle front.
7. Rotate the front passenger air bag module and release the rear side hooks (1) from the instrument panel.
8. Remove the front passenger air bag module from the instrument panel.

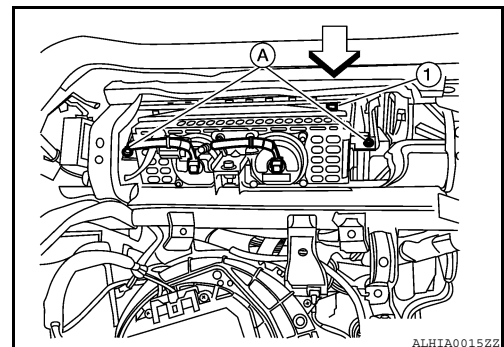

INSTALLATION - ORIGINAL PASSENGER AIR BAG MODULE

Installation is in the reverse order of removal.

CAUTION:

- Be careful not to damage the harness while installing.
- After the work is completed, make sure no system malfunction is detected by air bag warning lamp.

A
B
C
D
E
F
G
SR
I
J
K
L
M
N
O
P

FRONT PASSENGER AIR BAG MODULE

< ON-VEHICLE REPAIR >

- In case a malfunction is detected by the air bag warning lamp, reset with the self-diagnosis function and delete the memory by CONSULT-III.
- If a malfunction is still detected after the above operation, perform self-diagnosis to repair malfunctions. Refer to [SRC-12, "SRS Operation Check"](#).

INSTALLATION - SERVICE REPLACEMENT PASSENGER AIR BAG MODULE

1. Install front passenger air bag module to the instrument panel assembly.
2. Install the instrument panel assembly. Refer to [IP-11, "Removal and Installation"](#).
3. Connect the front passenger air bag module harness connector to yellow 4-pin service replacement connector and fasten to mounting bracket.

Wiring Harness Modification

The front passenger air bag module originally installed in the vehicle uses direct-connect style harness connectors. Service replacement passenger air bag modules use tab-locking style harness connectors. If the front passenger air bag module is replaced, or if the direct-connect harness connectors are damaged, the vehicle wiring harness must be modified to allow connection of the service replacement front passenger air bag module.

NOTE:

The wiring harness modification is to be performed only if the vehicle is equipped with the original front passenger air bag module which uses direct-connect harness connectors. If the front passenger air bag module is to be replaced in a vehicle that has already had the service replacement front passenger air bag module installed, the wiring harness modification is not required.

1. Locate the yellow and orange direct-connect front passenger air bag module harness connectors.
2. Use wire cutters to cut back both previously used direct-connect front passenger air bag module harness connectors from the vehicle wiring harness approximately 50 mm (1.9 in) from the connectors.
3. Remove approximately 150 mm (5.9 in) of the vehicle harness covering from the cut end.
4. Slide a piece of dual-wall heat shrink tubing (provided in the passenger air bag module service kit) onto each wire of the previously used vehicle wiring harness.

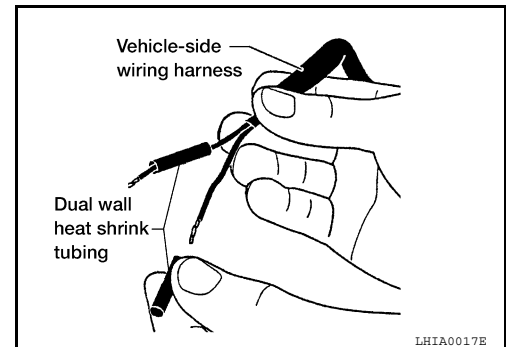

5. Fold each wire back and insert into the end of the heat shrink tubing so that the end of the wire is approximately centered in the heat shrink tubing.
6. Use a heat gun to shrink the heat shrink tubing and seal the wire.
7. Use electrical tape to secure the modified circuits to the outside of the wiring harness.

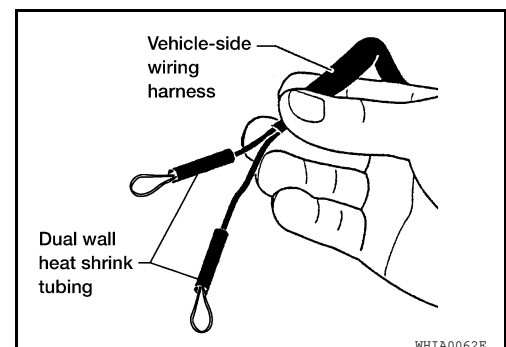

8. Locate the front passenger air bag module service replacement connector that is taped back to the main harness. Unwrap the tape to access the yellow service replacement connector and remove the dust cover from the connector.
 9. Connect service connector to front passenger air bag module.
 10. Clip to service connector clipping point.
- After the work is completed, perform self-diagnosis to check that no malfunction is detected. Refer to [SRC-12, "SRS Operation Check"](#).

SIDE CURTAIN AIR BAG MODULE

< ON-VEHICLE REPAIR >

SIDE CURTAIN AIR BAG MODULE

Exploded View

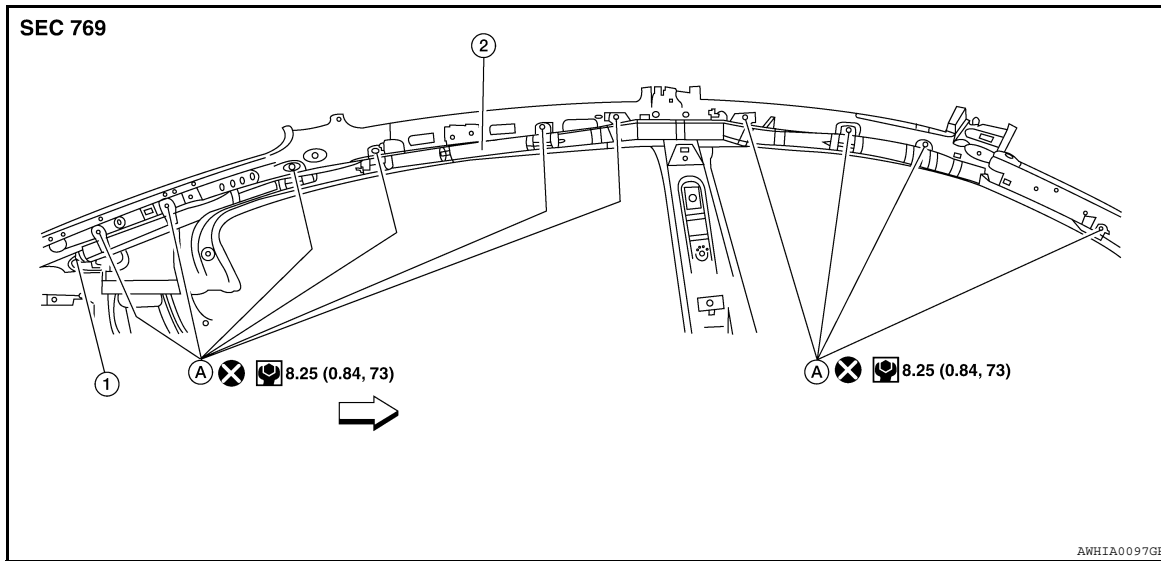

1. Side curtain air bag module connector 2. Side curtain air bag module A. Side curtain air bag module bolt
↔ Vehicle front

Removal and Installation

INFOID:000000005440356

REMOVAL

CAUTION:

- Before servicing, turn ignition switch OFF, disconnect both 12-volt battery terminals and wait at least 3 minutes.
- Do not use air tools or electric tools for servicing.
- Always work from the side of air bag module. Do not work from the front of it.
- Always place the curtain air bag module with air bag deployment side facing upward.
- Do not cause impact to the air bag module by dropping etc. Replace the air bag module if it has been dropped or sustained an impact.

1. Disconnect the 12-volt battery negative and positive terminals, then wait at least 3 minutes.
2. Remove the headlining. Refer to [INT-26, "Removal and Installation"](#).
3. Disconnect the side curtain air bag module connector.
 - For installing/removing direct-connect SRS connectors, refer to [SRC-9, "Direct-connect SRS Component Connectors"](#).
4. Remove the bolts, then remove side curtain air bag module.

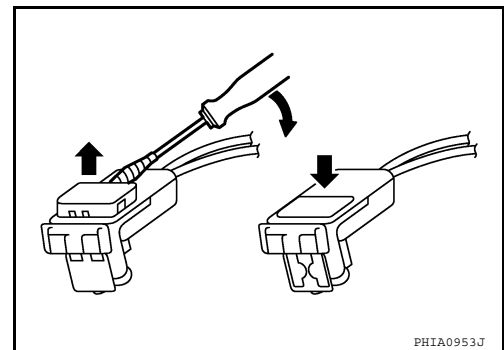

INSTALLATION

Installation is in the reverse order of removal.

CAUTION:

- Be careful not to damage the air bag harness.
- After the work is completed, make sure no system malfunction is detected by air bag warning lamp.
- In case a malfunction is detected by the air bag warning lamp, reset by the self-diagnosis function and delete the memory by CONSULT-III.

SIDE CURTAIN AIR BAG MODULE

< ON-VEHICLE REPAIR >

- If a malfunction is still detected after the above operation, perform self-diagnosis to repair malfunctions. Refer to [SRC-12, "SRS Operation Check"](#).
- Make sure the side curtain air bag module is not twisted at any point along the vehicle when installed.

CRASH ZONE SENSOR

< ON-VEHICLE REPAIR >

CRASH ZONE SENSOR

Exploded View

INFOID:000000005440357

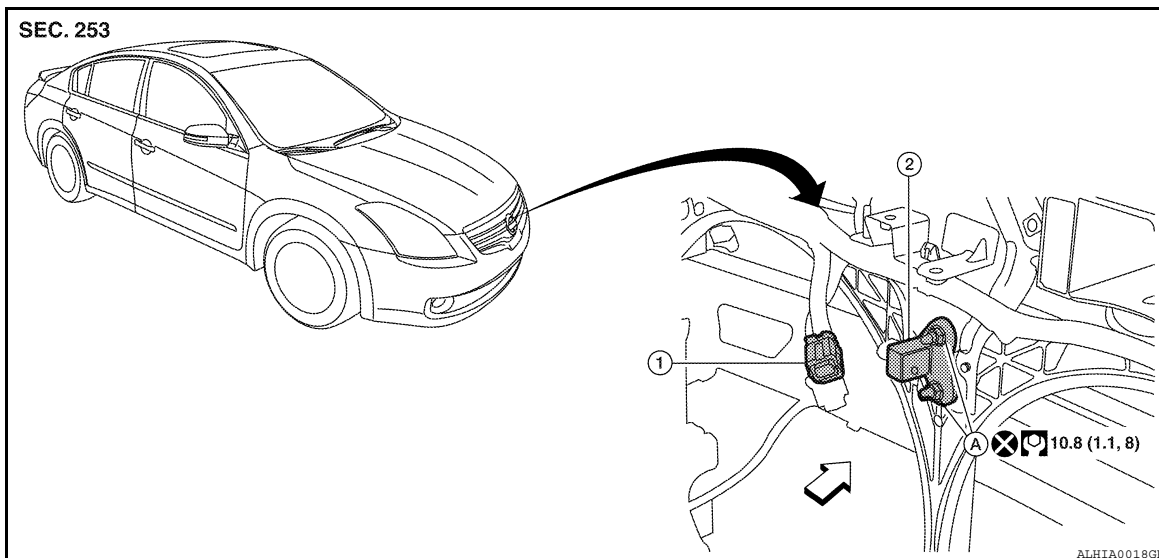

1. Crash zone sensor harness connector
2. Crash zone sensor
A. Crash zone sensor nuts

← Vehicle front

SR

Removal and Installation

INFOID:000000005440358

REMOVAL

CAUTION:

- Before servicing, turn ignition switch OFF, disconnect both 12-volt battery terminals and wait at least 3 minutes.
- Do not use air tools or electric tools for servicing.
- Do not use old fixing nuts after removal; replace with new nuts.
- Do not cause impact to the crash zone sensor by dropping etc. Replace the crash zone sensor if it has been dropped or sustained an impact.
- Replace the crash zone sensor of deployed SRS driver air bag and deployed SRS front passenger air bag.

1. Disconnect the 12-volt battery negative and positive terminals, then wait at least 3 minutes.
2. Remove the cover and the air duct.
3. Disconnect the crash zone sensor harness connector.
4. Remove the nuts, then remove crash zone sensor.

INSTALLATION

Installation is in the reverse order of removal.

CAUTION:

- Be careful not to damage the crash zone sensor harness.
- After the work is completed, make sure no system malfunction is detected by air bag warning lamp.
- In case a malfunction is detected by the air bag warning lamp, reset by the self-diagnosis function and delete the memory by CONSULT-III.
- If a malfunction is still detected after the above operation, perform self-diagnosis to repair malfunctions. Refer to [SRC-12, "SRS Operation Check"](#).

SIDE AIR BAG (SATELLITE) SENSOR

< ON-VEHICLE REPAIR >

SIDE AIR BAG (SATELLITE) SENSOR

Exploded View

INFOID:000000005440359

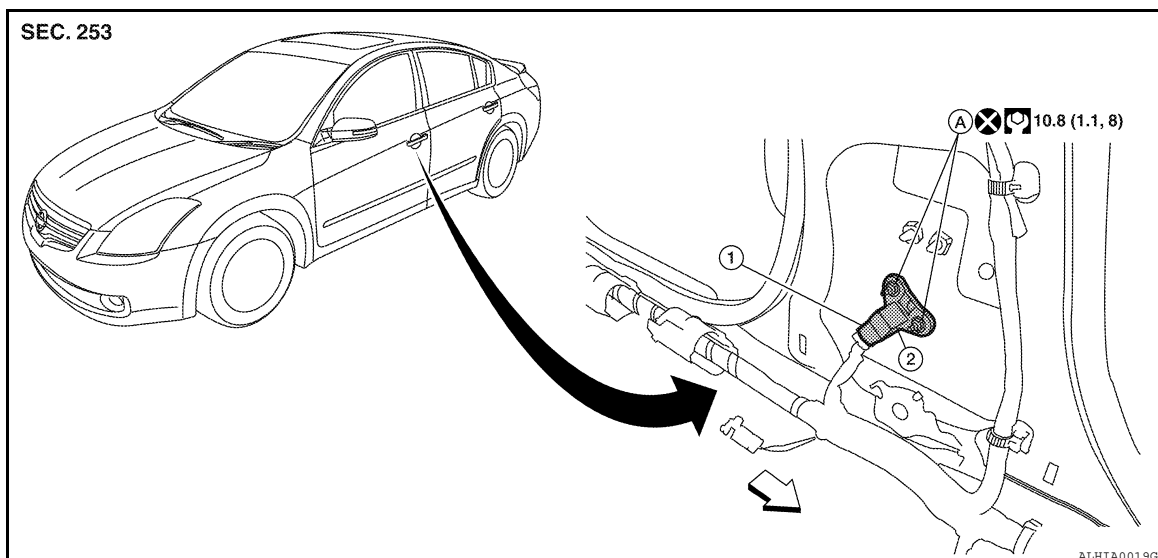

1. Side air bag (satellite) sensor harness connector 2. Side air bag (satellite) sensor A. Side air bag (satellite) sensor nuts

↶ Vehicle front

Removal and Installation

INFOID:000000005440360

REMOVAL

CAUTION:

- Before servicing, turn ignition switch OFF, disconnect both 12-volt battery terminals and wait at least 3 minutes.
- Do not use air tools or electric tools for servicing.
- Do not use old fixing nuts after removal; replace with new nuts.
- Do not cause impact to the side air bag (satellite) sensor by dropping etc. Replace the side air bag (satellite) sensor if it has been dropped or sustained an impact.
- Replace the satellite sensor of deployed SRS front side air bag and deployed SRS side curtain air bag.

1. Disconnect the 12-volt battery negative and positive terminals, then wait at least 3 minutes.
2. Remove the front seat belt retractor. Refer to [SB-6, "Removal and Installation"](#).
3. Disconnect the side air bag (satellite) sensor harness connector.
4. Remove the nuts, then remove side air bag (satellite) sensor.

INSTALLATION

Installation is in the reverse order of removal.

CAUTION:

- Be careful not to damage the satellite sensor harness.
- After the work is completed, make sure no system malfunction is detected by air bag warning lamp.
- In case a malfunction is detected by the air bag warning lamp, reset by the self-diagnosis function and delete the memory by CONSULT-III.
- If a malfunction is still detected after the above operation, perform self-diagnosis to repair malfunctions. Refer to [SRC-12, "SRS Operation Check"](#).

DIAGNOSIS SENSOR UNIT

< ON-VEHICLE REPAIR >

DIAGNOSIS SENSOR UNIT

Exploded View

INFOID:000000005440361

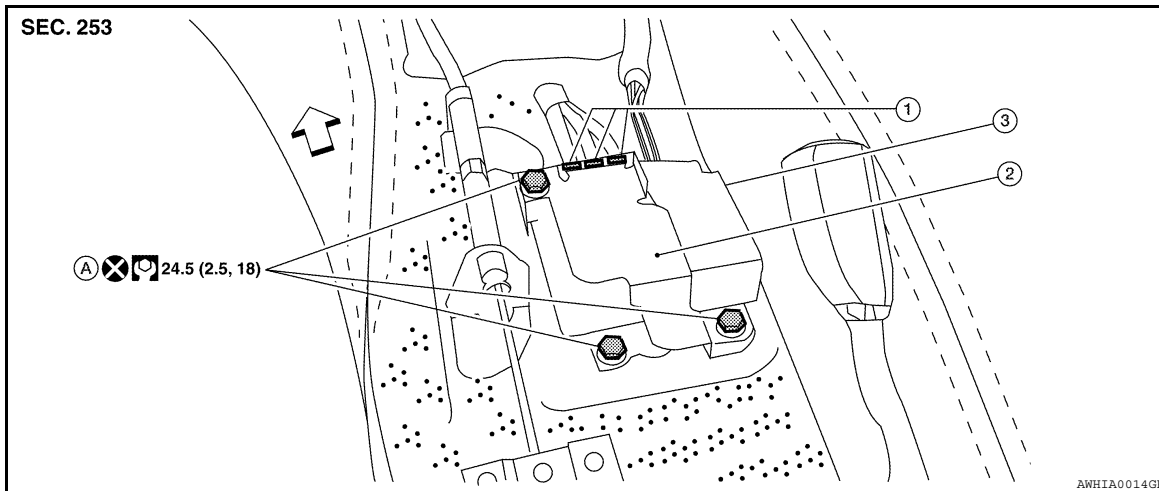

1. Diagnosis sensor unit harness connector 2. Diagnosis sensor unit shield 3. Diagnosis sensor unit
- A. Diagnosis sensor unit bolts ← Vehicle front

Removal and Installation

INFOID:000000005440362

REMOVAL

CAUTION:

- Before servicing, turn ignition switch OFF, disconnect both 12-volt battery terminals and wait at least 3 minutes.
- Before disconnecting the air bag sensor unit harness connector, be sure to disconnect the harness connector of each air bag module and pre-tensioner seat belt to prevent air bag deployment by static electricity.
- Do not use air tools or electric tools for servicing.
- Do not use old bolts after removal; replace with new bolts.
- Do not cause an impact to the diagnosis sensor unit by dropping etc. Replace the diagnosis sensor unit if it has been dropped or sustained an impact.
- Replace the diagnosis sensor unit of deployed SRS air bag and deployed SRS front seat belt pre-tensioner.
- When replacing the air bag diagnosis sensor unit, always check with the parts department for the latest parts information. Installing an incorrect air bag diagnosis sensor unit may or may not cause the air bag warning lamp to illuminate and may cause incorrect deployment of the supplemental air bags and seat belt pre-tensioner in a collision resulting in serious personal injury or death.

1. Always check the air bag diagnosis sensor unit ECU discriminated number (identification number) using CONSULT-III.
2. Disconnect the 12-volt battery negative and positive terminals, then wait at least 3 minutes.
3. Disconnect connector of each air bag module and seat belt pre-tensioner. Refer to [SR-4, "Removal and Installation"](#) (Driver air bag module), [SR-9, "Removal and Installation"](#) (Front passenger air bag module), [SR-11, "Removal and Installation"](#) (Side curtain air bag module), [SE-29, "PASSENGER SIDE : Disassembly"](#) (Side air bag), [SR-11, "Removal and Installation"](#) (Front seat belt retractor).
4. Remove the center console. Refer to [IP-11, "Removal and Installation"](#).
5. Disconnect the diagnosis sensor unit harness connectors.
6. Remove the bolts, then remove the diagnosis sensor unit.

INSTALLATION

Installation is in the reverse order of removal.

CAUTION:

DIAGNOSIS SENSOR UNIT

< ON-VEHICLE REPAIR >

- Be careful not to damage the diagnosis sensor unit harness.
- After the work is completed, make sure no system malfunction is detected by air bag warning lamp.
- In case a malfunction is detected by the air bag warning lamp, reset by the self-diagnosis function and delete the memory by CONSULT-III.
- If a malfunction is still detected after the above operation, perform self-diagnosis to repair malfunctions. Refer to [SRC-12. "SRS Operation Check"](#).
- After replacing the air bag diagnosis sensor unit, confirm using CONSULT-III that the ECU discriminated number (identification number) of the new replacement air bag diagnosis sensor unit matches the ECU discriminated number (identification number) of the replaced (old) air bag diagnosis sensor unit.

NOTE:

If the ECU discriminated number of the new replacement air bag diagnosis sensor unit differs from the ECU discriminated number of the replaced air bag diagnosis sensor unit, reconfirm the parts information and verify that the correct air bag diagnosis sensor unit was installed.

OCCUPANT CLASSIFICATION SYSTEM CONTROL UNIT

< ON-VEHICLE REPAIR >

OCCUPANT CLASSIFICATION SYSTEM CONTROL UNIT

Removal and Installation

INFOID:000000005440363

The occupant classification system control unit, occupant classification system sensor, and sensor mat are an integral part of the front passenger seat cushion and are replaced as an assembly. Refer to [SE-29, "PASSENGER SIDE : Disassembly"](#).

A

B

C

D

E

F

G

SR

I

J

K

L

M

N

O

P

COLLISION DIAGNOSIS

< ON-VEHICLE REPAIR >

COLLISION DIAGNOSIS

For Frontal Collision

INFOID:000000005809572

FOR FRONTAL COLLISION: When SRS is activated in a collision

CAUTION:

Due to varying models and option levels, not all parts listed in the chart below apply to all vehicles.

WORK PROCEDURE

1. Before performing any of the following steps, ensure that all vehicle body and structural repairs have been completed.
2. Replace the diagnosis sensor unit.
3. Remove the front air bag modules, crash zone sensor assembly, bracket and seat belt pre-tensioner assemblies.
4. Check the SRS components using the table below:
Replace any SRS components showing visible signs of damage. (dents, cracks and deformation, etc.)
5. Install new front air bag modules, crash zone sensor assembly, bracket and seat belt pre-tensioner assemblies.
6. Perform self-diagnosis using CONSULT-III or air bag warning lamp. Refer to [SRC-14, "Self-Diagnosis Function \(Without CONSULT-III\)"](#) for details.
Ensure entire SRS operates properly.
7. After the work is completed, perform self-diagnosis to check that no malfunction is detected. Refer to [SRC-12, "SRS Operation Check"](#).

SRS INSPECTION (FOR FRONTAL COLLISION)

Part	Inspection
Driver air bag module	If the driver air bag has deployed: REPLACE Install with new fasteners.
Front passenger air bag module (if equipped)	If the front passenger air bag has deployed: REPLACE Install with new fasteners.
Crash zone sensor	If any of the front air bags or seat belt pre-tensioners* have been activated: REPLACE the crash zone sensor and bracket with new fasteners. *: Confirm seat belt pre-tensioner activation using CONSULT-III only.
Seat belt pre-tensioner assemblies (All applicable locations: buckle, retractor, lap outer)	If either the driver or passenger seat belt pre-tensioner* has been activated: REPLACE all seat belt pre-tensioner assemblies with new fasteners. *: Confirm seat belt pre-tensioner activation using CONSULT-III only.
Diagnosis sensor unit	If any of the SRS components have been activated: REPLACE the diagnosis sensor unit. Install with new fasteners.
Steering wheel	<ol style="list-style-type: none"> 1. Visually check steering wheel for deformities. 2. Check harness (built into steering wheel) and connectors for damage, and terminals for deformities. 3. Install driver air bag module into the steering wheel to check fit and alignment with the wheel. 4. Check steering wheel for excessive free play. 5. If no damage is found, reinstall. 6. If damaged—REPLACE.
Spiral cable	If the driver front air bag has deployed: REPLACE the spiral cable.
Occupant classification system (Passenger seat)	<ol style="list-style-type: none"> 1. Remove passenger seat assembly. 2. Check control unit case for dents, cracks or deformities. 3. Check connectors and pressure sensor tube for damage, and terminals for deformities. 4. Check seat frame and cushion pan for dents or deformities. 5. If no damage is found, reinstall seat with new fasteners. 6. If damaged — REPLACE seat cushion assembly with new fasteners.

COLLISION DIAGNOSIS

< ON-VEHICLE REPAIR >

Part	Inspection
Harness and connectors	<ol style="list-style-type: none"> 1. Check connectors for poor connection, damage, and terminals for deformities. 2. Check harness for binding, chafing, cuts, or deformities. 3. If no damage is found, reinstall the harness and connectors. 4. If damaged—REPLACE the damaged harness. Do not attempt to repair, splice or modify any SRS harness.
Instrument panel assembly	If the passenger front air bag has deployed: REPLACE the instrument panel assembly. (integrated type)

FOR FRONTAL COLLISION: When SRS is not activated in a collision

CAUTION:

Due to varying models and option levels, not all parts listed in the chart below apply to all vehicles.

WORK PROCEDURE

1. Before performing any of the following steps, ensure that all vehicle body and structural repairs have been completed.
2. Check the SRS components using the table below:
Replace any SRS components showing visible signs of damage. (dents, cracks and deformation, etc.)
3. Perform self-diagnosis using CONSULT-III or air bag warning lamp. Refer to [SRC-14. "Self-Diagnosis Function \(Without CONSULT-III\)"](#) for details.
Ensure entire SRS operates properly.
4. After the work is completed, perform self-diagnosis to check that no malfunction is detected. Refer to [SRC-12. "SRS Operation Check"](#).

SRS INSPECTION (FOR FRONTAL COLLISION)

Part	Inspection
Driver air bag module	<p>If the driver air bag has NOT been activated:</p> <ol style="list-style-type: none"> 1. Remove driver air bag module. Check harness cover and connectors for damage, terminals for deformities, and harness for binding. 2. Install driver air bag module into the steering wheel to check fit and alignment with the wheel. 3. If no damage is found, reinstall with new fasteners. 4. If damaged—REPLACE. Install driver air bag modules with new fasteners.
Front passenger air bag module (if equipped)	<p>If the front passenger air bag has NOT been activated:</p> <ol style="list-style-type: none"> 1. Remove front passenger air bag module. Check harness cover and connectors for damage, terminals for deformities, and harness for binding. 2. Install front passenger air bag module into the instrument panel to check fit with the instrument panel. 3. If no damage is found, reinstall with new fasteners. 4. If damaged—REPLACE. Install front passenger air bag modules with new fasteners.
Crash zone sensor	<p>If the front air bags or seat belt pre-tensioners have NOT been activated:</p> <ol style="list-style-type: none"> 1. Remove the crash zone sensor. Check harness connectors for damage, terminals for deformities, and harness for binding. 2. Check for visible signs of damage (dents, cracks, deformation) of the crash zone sensor and bracket. 3. Install the crash zone sensor to check fit. 4. If no damage is found, reinstall with new fasteners. 5. If damaged—REPLACE the crash zone sensor and bracket with new fasteners.
Seat belt pre-tensioner assemblies (All applicable locations: buckle, retractor, lap outer)	<p>If the pre-tensioners have NOT been activated:</p> <ol style="list-style-type: none"> 1. Remove seat belt pre-tensioners. Check harness cover and connectors for damage, terminals for deformities, and harness for binding. 2. Check belts for damage and anchors for loose mounting. 3. Check retractor for smooth operation. 4. Check seat belt adjuster for damage. 5. Check for deformities of the center pillar inner. 6. If the center pillar inner has no damage, REPLACE the seat belt pre-tensioner assembly. 7. If no damage is found, reinstall seat belt pre-tensioner assembly. 8. If damaged—REPLACE. Install the seat belt pre-tensioners with new fasteners.

COLLISION DIAGNOSIS

< ON-VEHICLE REPAIR >

Part	Inspection
Diagnosis sensor unit	If none of the SRS components have been activated: <ol style="list-style-type: none"> 1. Check case for dents, cracks or deformities. 2. Check connectors for damage, and terminals for deformities. 3. If no damage is found, reinstall with new fasteners. 4. If damaged—REPLACE. Install diagnosis sensor unit with new fasteners.
Steering wheel	<ol style="list-style-type: none"> 1. Visually check steering wheel for deformities. 2. Check harness (built into steering wheel) and connectors for damage, and terminals for deformities. 3. Install driver air bag module into the steering wheel to check fit and alignment with the wheel. 4. Check steering wheel for excessive free play. 5. If no damage is found, reinstall. 6. If damaged—REPLACE.
Spiral cable	If the driver front air bag has not deployed: <ol style="list-style-type: none"> 1. Visually check spiral cable and combination switch for damage. 2. Check connectors and protective tape for damage. 3. Check steering wheel for noise, binding or heavy operation. 4. If no damage is found, reinstall. 5. If damaged—REPLACE.
Occupant classification system (Passenger seat)	<ol style="list-style-type: none"> 1. Remove passenger seat assembly. 2. Check control unit case for dents, cracks or deformities. 3. Check connectors and pressure sensor tube for damage, and terminals for deformities. 4. Check seat frame and cushion pan for dents or deformities. 5. If no damage is found, reinstall seat with new fasteners. 6. If damaged — REPLACE seat cushion assembly with new fasteners.
Harness and connectors	<ol style="list-style-type: none"> 1. Check connectors for poor connection, damage, and terminals for deformities. 2. Check harness for binding, chafing, cuts, or deformities. 3. If no damage is found, reinstall the harness and connectors. 4. If damaged—REPLACE the damaged harness. Do not attempt to repair, splice or modify any SRS harness.
Instrument panel assembly	If the passenger front air bag has NOT deployed: <ol style="list-style-type: none"> 1. Visually check instrument panel for damage. 2. If no damage is found, reinstall the instrument panel assembly. 3. If damaged—REPLACE the instrument panel assembly.

For Side and Rollover Collision

INFOID:000000005809573

FOR SIDE AND ROLLOVER COLLISION: When SRS is activated in a collision

CAUTION:

Due to varying models and option levels, not all parts listed in the chart below apply to all vehicles.

WORK PROCEDURE

1. Before performing any of the following steps, ensure that all vehicle body and structural repairs have been completed.
2. Replace the following components:
 - Front seat back assembly (on the side on which side air bag is activated).
 - Door finisher (on the side on which door-mounted curtain air bag is activated).
 - Pop-up roll bar assemblies and pop-up roll bar covers.
 - Side air bag (satellite) sensor LH/RH (on the side on which side air bag is activated).
 - Diagnosis sensor unit.
 - Seat belt pre-tensioner assemblies.
3. Check the SRS components and the related parts using the following table. Replace any SRS components and the related parts showing visible signs of damage (dents, cracks, deformation, etc.).
4. Perform self-diagnosis using CONSULT-III and "AIR BAG" warning lamp. Refer to [SRC-12, "SRS Operation Check"](#) for details. Make sure entire SRS operates properly.
5. After the work is completed, perform self-diagnosis to check that no malfunction is detected. Refer to [SRC-14, "Self-Diagnosis Function \(Without CONSULT-III\)"](#).

SRS INSPECTION (FOR SIDE AND ROLLOVER COLLISION)

COLLISION DIAGNOSIS

< ON-VEHICLE REPAIR >

Part	Inspection	A
Side curtain air bag module LH	If the side curtain air bag LH has deployed: REPLACE the side curtain air bag module LH. Install with new fasteners.	B
Side curtain air bag module RH	If the side curtain air bag RH has deployed: REPLACE the side curtain air bag module RH. Install with new fasteners.	C
Front side air bag module LH	If the front side air bag LH has deployed: REPLACE front seatback assembly LH.	D
Front side air bag module RH	If the front side air bag RH has deployed: REPLACE front seatback assembly RH.	E
Side air bag (satellite) sensor (LH or RH)	If any of the SRS components have deployed: REPLACE the side air bag (satellite) sensor on the collision side with new fasteners.	F
Diagnosis sensor unit	If any of the SRS components have deployed: REPLACE the diagnosis sensor unit with new fasteners.	G
Seat belt pre-tensioner assemblies (All applicable locations: buckle, retractor, lap outer)	If either the driver or passenger seat belt pre-tensioner* has been activated: REPLACE all seat belt pre-tensioner assemblies with new fasteners. *: Confirm seat belt pre-tensioner activation using CONSULT-III only.	SR
Center inner pillar	1. Check the center inner pillar on the collision side for damage (dents, cracks, deformation). 2. If damaged—REPAIR the center inner pillar.	I
Seat (if equipped with front side air bag)	If either the front LH or front RH side air bag modules has been deployed: REPLACE front seatback assembly on the deployed side.	J
Trim/headlining	1. Check for visible signs of damage (dents, cracks, deformation) of the interior trim on the collision side. 2. If damaged—REPLACE the damaged trim parts.	K
Door-mounted curtain air bag module LH	If the door-mounted curtain air bag module LH has been deployed: REPLACE the door finisher LH and door-mounted curtain air bag module. Install with new fasteners.	L
Door-mounted curtain air bag module RH	If the door-mounted curtain air bag module RH has been deployed: REPLACE the door finisher RH and door-mounted curtain air bag module. Install with new fasteners.	M
Pop-up roll bar assemblies	If the pop-up roll bar has deployed: REPLACE pop-up roll bar assemblies and pop-up roll bar covers. Install with new fasteners.	N

FOR SIDE AND ROLLOVER COLLISION: When SRS is not activated in a collision

CAUTION:

Due to varying models and option levels, not all parts listed in the chart below apply to all vehicles.

WORK PROCEDURE

1. Before performing any of the following steps, ensure that all vehicle body and structural repairs have been completed.
2. Check the SRS components and the related parts using the following table.
 - If the front seat back assembly is damaged, the front seat back assembly must be replaced.
 - If the door finisher assembly is damaged, the door finisher assembly and door-mounted curtain air bag module must be replaced.
3. Perform self-diagnosis using CONSULT-III and "AIR BAG" warning lamp. Refer to [SRC-12. "SRS Operation Check"](#) for details. Make sure entire SRS operates properly.
4. After the work is completed, perform self-diagnosis to check that no malfunction is detected. Refer to [SRC-14. "Self-Diagnosis Function \(Without CONSULT-III\)"](#).

SRS INSPECTION (FOR SIDE AND ROLLOVER COLLISION)

COLLISION DIAGNOSIS

< ON-VEHICLE REPAIR >

Part	Inspection
Side curtain air bag module LH	<p>If the side curtain air bag LH has NOT deployed:</p> <ol style="list-style-type: none"> 1. Check for visible signs of damage (dents, tears, deformation) of the center pillar on the collision side. 2. If damaged—Remove the side curtain air bag module LH. 3. Check for visible signs of damaged (tears etc.) of the side curtain air bag module LH. 4. Check harness and connectors for damage, and terminals for deformities. 5. If no damage is found, reinstall the side curtain air bag module LH with new fasteners. 6. If damaged—REPLACE the side curtain air bag module LH with new fasteners.
Side curtain air bag module RH	<p>If the side curtain air bag RH has NOT deployed:</p> <ol style="list-style-type: none"> 1. Check for visible signs of damage (dents, tears, deformation) of the center pillar on the collision side. 2. If damaged—Remove the side curtain air bag module RH. 3. Check for visible signs of damaged (tears etc.) of the side curtain air bag module RH. 4. Check harness and connectors for damage, and terminals for deformities. 5. If no damage is found, reinstall the side curtain air bag module RH with new fasteners. 6. If damaged—REPLACE the side curtain air bag module RH with new fasteners.
Front side air bag module LH	<p>If the front LH side air bag has NOT deployed:</p> <ol style="list-style-type: none"> 1. Check for visible signs of damage (dents, tears, deformation) of the seat back on the collision side. 2. Check harness and connectors for damage, and terminals for deformities. 3. If damaged—REPLACE the front seatback assembly LH.
Front side air bag module RH	<p>If the front side air bag RH has NOT deployed:</p> <ol style="list-style-type: none"> 1. Check for visible signs of damage (dents, tears, deformation) of the seat back on the collision side. 2. Check harness and connectors for damage, and terminals for deformities. 3. If damaged—REPLACE the front seatback assembly RH.
Side air bag (satellite) sensor (LH or RH)	<p>If none of the SRS components have been activated:</p> <ol style="list-style-type: none"> 1. Remove the side air bag (satellite) sensor (LH or RH) on the collision side. Check harness connectors for damage, terminals for deformities, and harness for binding. 2. Check for visible signs of damage (dents, cracks, deformation) of the side air bag (satellite) sensor (LH or RH). 3. Install the side air bag (satellite) sensor (LH or RH) to check fit. 4. If no damage is found, reinstall the side sir bag (satellite) sensor (LH or RH) with new fasteners. 5. If damaged—REPLACE the side air bag (satellite) sensor (LH or RH) with new fasteners.
Diagnosis sensor unit	<p>If none of the SRS components have been activated:</p> <ol style="list-style-type: none"> 1. Check case and bracket for dents, cracks or deformities. 2. Check connectors for damage, and terminals for deformities. 3. If no damage is found, reinstall the diagnosis sensor unit with new fasteners. 4. If damaged—REPLACE the diagnosis sensor unit with new fasteners.
Seat belt pre-tensioner assemblies (All applicable locations: buckle, retractor, lap outer)	<p>If the pre-tensioners have NOT been activated:</p> <ol style="list-style-type: none"> 1. Remove seat belt pre-tensioners. Check harness cover and connectors for damage, terminals for deformities, and harness for binding. 2. Check belts for damage and anchors for loose mounting. 3. Check retractor for smooth operation. 4. Check seat belt adjuster for damage. 5. Check for deformities of the center pillar inner. 6. If the center pillar inner has no damage, REPLACE the seat belt pre-tensioner assembly. 7. If no damage is found, reinstall seat belt pre-tensioner assembly. 8. If damaged—REPLACE. Install the seat belt pre-tensioners with new fasteners.
Seat (with front side air bag)	<p>If the front LH or front RH side air bag modules have NOT deployed:</p> <ol style="list-style-type: none"> 1. Visually check the seat on the collision side. 2. Remove the seat on the collision side and check the following for damage and deformities. <ul style="list-style-type: none"> - Harness, connectors and terminals - Frame and recliner (for front and rear seat), and also adjuster and slides (for front seat) 3. If no damage is found, reinstall the seat. 4. If damaged—REPLACE the damaged seat parts using new fasteners. If the front seat back is damaged, the front seat back assembly must be replaced.

COLLISION DIAGNOSIS

< ON-VEHICLE REPAIR >

Part	Inspection	
Center inner pillar	<ol style="list-style-type: none"> 1. Check the center inner pillar on the collision side for damage (dents, cracks, deformation, etc.). 2. If damaged - REPAIR the center inner pillar. 	A
Trim/headlining	<ol style="list-style-type: none"> 1. Check for visible signs of damage (dents, cracks, deformation, etc.) of the interior trim on the collision side. 2. If damaged - REPLACE the damaged trim parts. 	B
Door-mounted curtain air bag module LH	<p>If the door-mounted curtain air bag LH has NOT deployed:</p> <ol style="list-style-type: none"> 1. Check for visible signs of damage (dents tears, deformation, etc.) of the door finisher on the collision side. 2. If damaged - REPLACE the door finisher LH with new fasteners. 3. Check for visible signs of damaged (dents etc.) of the door-mounted curtain air bag module LH. 4. Check harness and connectors for damage, and terminals for deformities. 5. If no damage is found, reinstall door finisher. <p>CAUTION: When removing door mounted curtain air bag module from door finisher, never reuse door finisher.</p> <ol style="list-style-type: none"> 6. If damaged - REPLACE the door finisher LH and door-mounted curtain air bag module LH with new fasteners. 	C D E F
Door-mounted curtain air bag module RH	<p>If the door-mounted curtain air bag RH has NOT deployed:</p> <ol style="list-style-type: none"> 1. Check for visible signs of damage (dents tears, deformation, etc.) of the door finisher on the collision side. 2. If damaged - REPLACE the door finisher RH with new fasteners. 3. Check for visible signs of damaged (tears etc.) of the door-mounted curtain air bag module RH. 4. Check harness and connectors for damage, and terminals for deformities. 5. If no damage is found, reinstall door finisher. <p>CAUTION: When removing door mounted curtain air bag module from door finisher, never reuse door finisher.</p> <ol style="list-style-type: none"> 6. If damaged - REPLACE the door finisher RH and door-mounted curtain air bag module RH with new fasteners. 	G SR I
Pop-up roll bar	<p>If the pop-up roll bar NOT deployed:</p> <ol style="list-style-type: none"> 1. Check for visible signs of damage (dents tears, deformation, etc.) of the pop-up roll bar. 2. If damaged - REPLACE the pop-up roll bar with new fasteners. 3. Check harness and connectors for damage, and terminals for deformities. 4. If no damage is found, reinstall the pop-up roll bar with new fasteners. 5. Check for visible signs of damage (dents, cracks, deformation, etc.) of the seatback support brace assembly. 6. If damaged - REPAIR the seatback support brace assembly. 	J K L