

SECTION **ST**
STEERING SYSTEM

A
 B
 C
 D
 E
 F
ST
 H
 I
 J
 K
 L
 M
 N
 O
 P

CONTENTS

PRECAUTION	2	STEERING COLUMN	8
PRECAUTIONS	2	Exploded View	8
Precaution for Supplemental Restraint System (SRS) "AIR BAG" and "SEAT BELT PRE-TENSIONER"	2	Removal and Installation	8
Precautions For High-Voltage System	2	STEERING GEAR AND LINKAGE	11
General Precautions	2	Exploded View	11
SYMPTOM DIAGNOSIS	3	Removal and Installation	11
NOISE, VIBRATION AND HARSHNESS (NVH) TROUBLESHOOTING	3	DISASSEMBLY AND ASSEMBLY	13
NVH Troubleshooting Chart	3	STEERING COLUMN	13
PREPARATION	4	Disassembly and Assembly	13
PREPARATION	4	STEERING GEAR AND LINKAGE	14
Special Service Tool	4	Exploded View	14
Commercial Service Tool	4	Disassembly	14
ON-VEHICLE MAINTENANCE	5	Inspection	14
STEERING WHEEL	5	Assembly	15
Inspection	5	SERVICE DATA AND SPECIFICATIONS (SDS)	16
ON-VEHICLE REPAIR	7	SERVICE DATA AND SPECIFICATIONS (SDS)	16
STEERING WHEEL	7	Steering Wheel	16
Removal and Installation	7	Steering Angle	16
		Steering Column	16
		Steering Gear	17

PRECAUTIONS

< PRECAUTION >

PRECAUTION

PRECAUTIONS

Precaution for Supplemental Restraint System (SRS) "AIR BAG" and "SEAT BELT PRE-TENSIONER"

INFOID:000000005804653

The Supplemental Restraint System such as "AIR BAG" and "SEAT BELT PRE-TENSIONER", used along with a front seat belt, helps to reduce the risk or severity of injury to the driver and front passenger for certain types of collision. This system includes seat belt switch inputs and dual stage front air bag modules. The SRS system uses the seat belt switches to determine the front air bag deployment, and may only deploy one front air bag, depending on the severity of a collision and whether the front occupants are belted or unbelted. Information necessary to service the system safely is included in the SR and SB section of this Service Manual.

WARNING:

- To avoid rendering the SRS inoperative, which could increase the risk of personal injury or death in the event of a collision which would result in air bag inflation, all maintenance must be performed by an authorized NISSAN/INFINITI dealer.
- Improper maintenance, including incorrect removal and installation of the SRS, can lead to personal injury caused by unintentional activation of the system. For removal of Spiral Cable and Air Bag Module, see the SR section.
- Do not use electrical test equipment on any circuit related to the SRS unless instructed to in this Service Manual. SRS wiring harnesses can be identified by yellow and/or orange harnesses or harness connectors.

PRECAUTIONS WHEN USING POWER TOOLS (AIR OR ELECTRIC) AND HAMMERS

WARNING:

- When working near the Airbag Diagnosis Sensor Unit or other Airbag System sensors with the Ignition ON or engine running, DO NOT use air or electric power tools or strike near the sensor(s) with a hammer. Heavy vibration could activate the sensor(s) and deploy the air bag(s), possibly causing serious injury.
- When using air or electric power tools or hammers, always switch the Ignition OFF, disconnect the battery, and wait at least 3 minutes before performing any service.

Precautions For High-Voltage System

INFOID:000000005440443

Refer to [GI-24, "Precautions For High-Voltage System"](#).

General Precautions

INFOID:000000005440445

- In case of removing steering gear assembly, make the final tightening with grounded and unloaded vehicle condition, and then check wheel alignment.
- Observe the following precautions when disassembling.
 - Before disassembly, thoroughly clean the outside of the unit.
 - Disassembly should be done in a clean work area. It is important to prevent the internal parts from becoming contaminated by dirt or other foreign matter.
 - For easier and proper assembly, place disassembled parts in order on a parts rack.
 - Use nylon cloth or paper towels to clean the parts; common shop rags can leave lint that might interfere with their operation.
 - Do not reuse non-reusable parts.
 - Before assembling, apply the specified grease to the directed parts.
- Perform EPS motor angle sensor initialization and torque sensor calibration when replacing steering gear assembly. Refer to [STC-5, "EPS MOTOR ANGLE SENSOR INITIALIZATION AND TORQUE SENSOR CALIBRATION : Special Repair Requirement"](#).

NOISE, VIBRATION AND HARSHNESS (NVH) TROUBLESHOOTING

< SYMPTOM DIAGNOSIS >

SYMPTOM DIAGNOSIS

NOISE, VIBRATION AND HARSHNESS (NVH) TROUBLESHOOTING

NVH Troubleshooting Chart

INFOID:000000005440441

Use chart below to help you find the cause of the symptom. If necessary, repair or replace these parts.

Symptom		Steering	Possible cause and SUSPECTED PARTS										Reference page											
			Outer socket ball joint swinging force	Outer socket ball joint rotating torque	Outer socket ball joint end play	Steering wheel play	Steering gear rack sliding force	Improper steering wheel	Mounting rubber deterioration	Steering column deformation or damage	Improper installation or looseness of steering column	Steering linkage looseness		WHEEL HUB AND AXLE	SUSPENSION	TIRES	ROAD WHEEL	DRIVE SHAFT	BRAKES					
Noise	Shake	Vibration	Shimmy	Shudder	x	x	x	x	x												ST-14			
																							ST-14	
																								ST-14
																								ST-5
																								ST-14
																				—				
																				ST-11				
																				ST-8				
																				ST-8				
																				ST-11				
																				FAX-3, "NVH Troubleshooting Chart"				
																				FSU-3, "NVH Troubleshooting Chart"				
																				WT-55, "NVH Troubleshooting Chart"				
																				WT-55, "NVH Troubleshooting Chart"				
																				FAX-3, "NVH Troubleshooting Chart"				
																				BR-6, "NVH Troubleshooting Chart"				

x: Applicable

A
B
C
D
E
F
ST
H
I
J
K
L
M
N
O
P

PREPARATION

< PREPARATION >

PREPARATION

PREPARATION

Special Service Tool

INFOID:000000005440446

The actual shapes of Kent-Moore tools may differ from those of special service tools illustrated here.

Tool number (Kent-Moore No.) Tool name	Description
ST27180001 (J-25726-A) Steering wheel puller <div data-bbox="617 546 909 714" style="text-align: center;"> <p>S-NT544</p> </div>	Removing steering wheel
ST3127S000 (See J-25765-A) Preload gauge 1. GG9103000 (J-25765-A) Torque wrench 2. HT62940000 (-) Socket adapter 3. HT62900000 (-) Socket adapter <div data-bbox="600 861 925 1029" style="text-align: center;"> <p>S-NT541</p> </div>	Inspecting of rotating torque for ball joint and steering column
— (J-44372) sPRING gauge <div data-bbox="665 1197 860 1323" style="text-align: center;"> <p>LST024</p> </div>	Measuring steering wheel turning force, rack sliding force and ball joint swinging force
HT72520000 (J-25730-A) Ball joint remover <div data-bbox="665 1365 860 1554" style="text-align: center;"> <p>NT146</p> </div>	Removing ball joint

Commercial Service Tool

INFOID:000000005440447

Tool number Tool name	Description
Power tool <div data-bbox="617 1806 925 1995" style="text-align: center;"> <p>PBIC0190E</p> </div>	<ul style="list-style-type: none"> • Removing wheel nuts • Removing undercover

STEERING WHEEL

< ON-VEHICLE MAINTENANCE >

ON-VEHICLE MAINTENANCE

STEERING WHEEL

Inspection

INFOID:000000005440448

STEERING WHEEL AXIAL END PLAY

- Check installation conditions of steering gear assembly, front suspension assembly, axle and steering column assembly.
- Check if movement exists when steering wheel is moved up and down, to the left and right and to the axial direction.

Steering wheel axial end play : 0 mm (0 in)

- Check steering gear assembly mounting bolts and nut for looseness. Refer to [ST-11. "Exploded View"](#).

STEERING WHEEL PLAY

- Turn steering wheel so that front wheels come to the straight-ahead position. Start engine and lightly turn steering wheel to the left and right until front wheels start to move. Measure steering wheel movement on the outer circumference as shown.

Steering wheel play : Refer to [ST-16. "Steering Wheel"](#).

- When the measurement value is outside the standard value, check backlash for each joint of steering column assembly and installation condition of steering gear assembly.

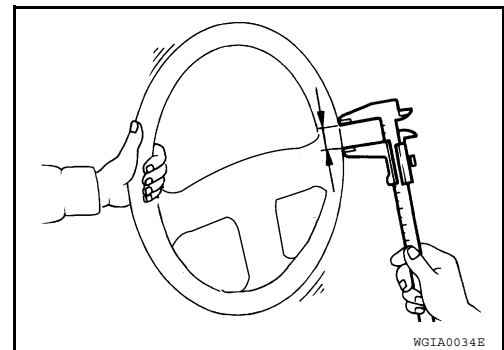

NEUTRAL POSITION OF STEERING WHEEL

- Make sure that steering gear assembly, steering column assembly and steering wheel are installed in the correct position.
- Perform neutral position inspection after wheel alignment. Refer to [BRC-9. "PERFORM ZERO POINT OF STEERING ANGLE SENSOR : Special Repair Requirement"](#).
- Set vehicle to the straight-ahead position and confirm steering wheel is in the neutral position.
- Loosen outer socket lock nut and turn inner socket to left and right equally to make fine adjustments if steering wheel is not in the neutral position.

STEERING WHEEL TURNING FORCE

1. Park vehicle on a level, dry surface and set parking brake.
2. Start engine.
3. Tires need to be inflated to normal pressure.
4. Check steering wheel turning force when steering wheel has been turned 360° from the neutral position using Tool.

Tool Number : — (J-44372)

Steering wheel turning force : Refer to [ST-16. "Steering Wheel"](#)

5. If steering wheel turning force is out of specification, check rack sliding force. Refer to [ST-14. "Inspection"](#).
6. If rack sliding force is not within specifications, adjust rack sliding force. Refer to [ST-14. "Inspection"](#).
7. If rack sliding force is OK, inspect steering column. Refer to [ST-8. "Removal and Installation"](#).

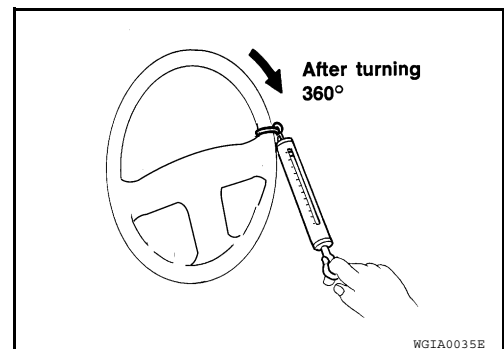

FRONT WHEEL TURNING ANGLE

STEERING WHEEL

< ON-VEHICLE MAINTENANCE >

- Check front wheel turning angle after toe-in inspection. Place front wheels on turning radius gauges and rear wheels on stands. Check the maximum inner and outer wheel turning angles for LH and RH road wheels.

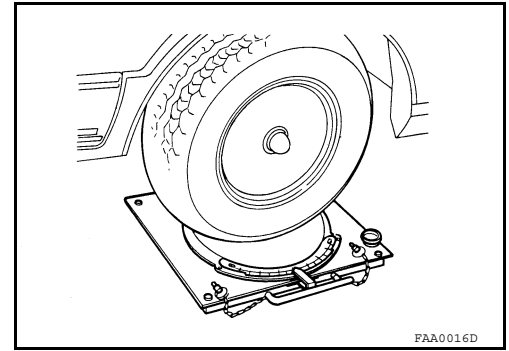

- With the engine at idle, turn steering wheel from full left stop to full right stop and measure the turning angles.

Inner wheel (Angle: A) : Refer to [ST-16, "Steering Angle"](#).
Outer wheel (Angle: B) : Refer to [ST-16, "Steering Angle"](#).

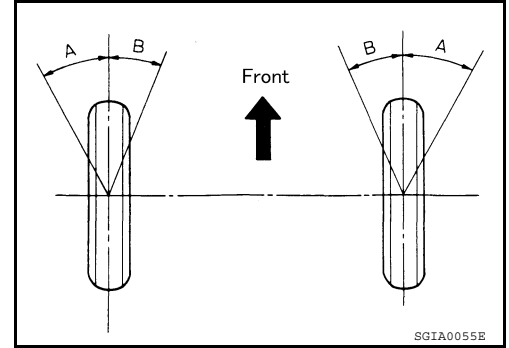

- Measure rack stroke if angles are outside the specified value.

Rack stroke (L) : Refer to [ST-17, "Steering Gear"](#).

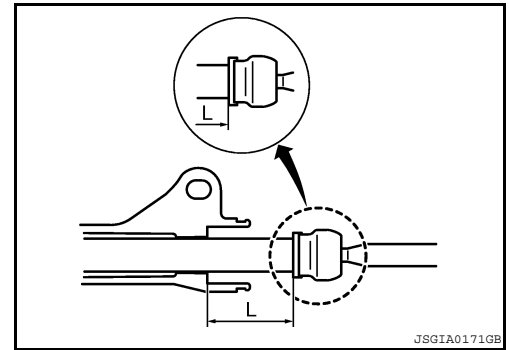

STEERING WHEEL

< ON-VEHICLE REPAIR >

ON-VEHICLE REPAIR

STEERING WHEEL

Removal and Installation

INFOID:000000005440449

REMOVAL

NOTE:

When reconnecting spiral cable, fix cable with a tape so that fixing case and rotating part keep aligned. This will omit neutral position alignment procedure during spiral cable installation.

1. Set front wheels to straight-ahead position.
2. Remove driver air bag module. Refer to [SR-9, "Removal and Installation"](#).
3. Remove steering wheel lock nut and washer after steering column is locked.
4. Remove steering wheel using Tool (A).

Tool number (A) : ST27180001 (J-25726-A)

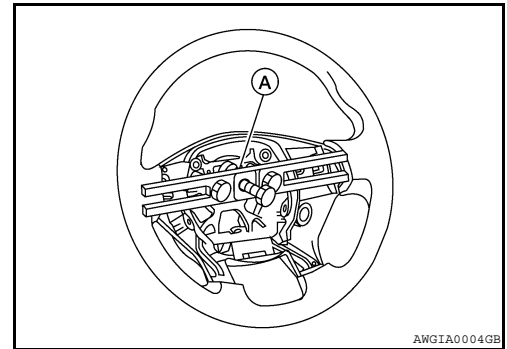

INSTALLATION

Installation is in the reverse order of removal.

Steering wheel lock nut : Refer to [ST-8, "Exploded View"](#).

- As necessary, set the spiral cable neutral position.
- Slowly turn the spiral cable clockwise to the end position.
- Next, turn it counterclockwise (approximately 2 turns) then stop turning at the point when the alignment arrows (B) are directly across from each other.
- Rotate the spiral cable slightly so the locating pin (2) is positioned at the top.

NOTE:

- A service part is installed in the neutral position with a stopper clip in place and should not be adjusted after the stopper clip is removed.
- Align the locating hole (1) at the top of the steering wheel with the locating pin (2) of the spiral cable during installation.
- Spiral cable screws (A)

CAUTION:

- **The spiral cable may snap by steering operation if the cable is installed in an improper position.**
- **Do not turn the spiral cable quickly or beyond the limit number of turns. (This can cause the cable to snap.)**
- **After the work is completed, make sure no system malfunction is detected by air bag warning lamp.**
- **In case a malfunction is detected by the air bag warning lamp, reset with the self-diagnosis function and delete the memory with CONSULT-III.**
- **If a malfunction is still detected after the above operation, perform self-diagnosis to repair malfunctions. Refer to [SRC-7, "Driver Air Bag Module"](#).**

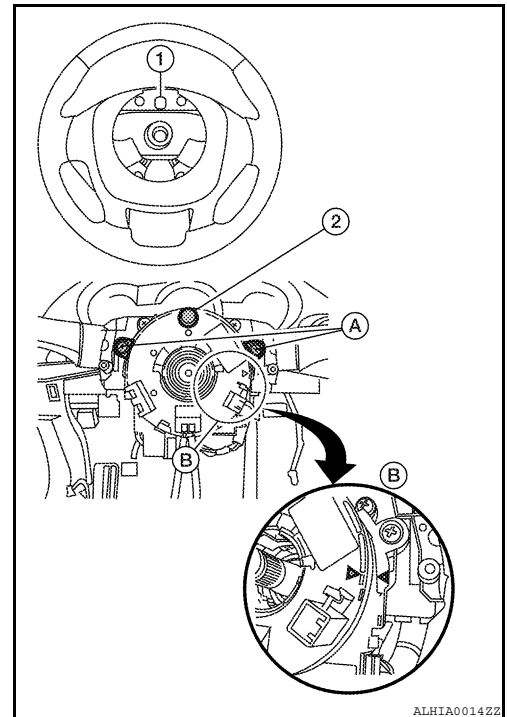

STEERING COLUMN

< ON-VEHICLE REPAIR >

STEERING COLUMN

Exploded View

INFOID:000000005440450

SEC. 481 • 488

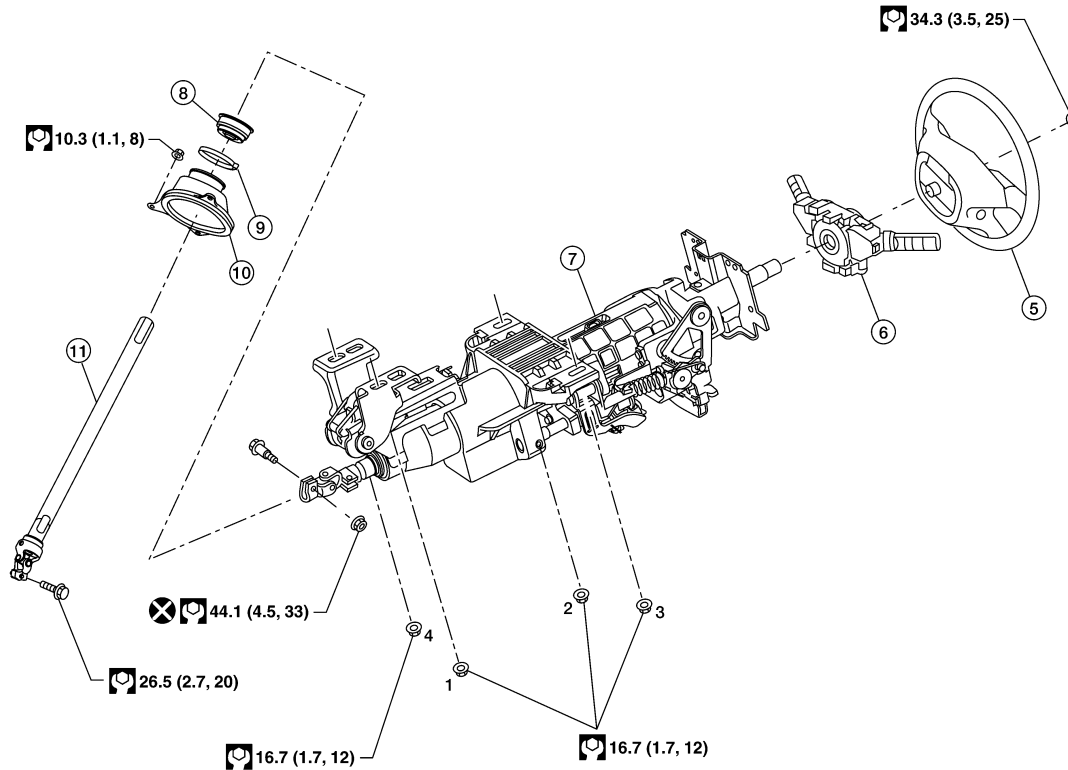

AWGIA0105GB

- | | | |
|--|--------------------------|--|
| 1-4. Steering column assembly nut tightening order | 5. Steering wheel | 6. Combination switch and spiral cable |
| 7. Steering column assembly | 8. Hole cover seal | 9. Herbie clip |
| 10. Hole cover | 11. Lower shaft assembly | |

Removal and Installation

INFOID:000000005440451

CAUTION:

- Any time the ignition switch has been disconnected, removed or installed, the keys must be re-registered in the BCM. Refer to Consult-III operations IVIS/NVIS.

REMOVAL

1. Disconnect 12 volt battery negative and positive terminals. Refer to [PG-71, "Removal and Installation"](#).
2. Set wheels to the straight ahead-position.

STEERING COLUMN

< ON-VEHICLE REPAIR >

3. Remove steering column shaft pinch bolts.

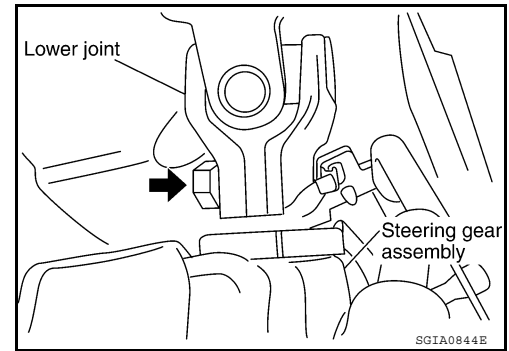

4. Loosen herbie clip, then remove hole cover seal from hole cover.
5. Remove instrument side mask (LH), instrument lower cover (LH) and steering column covers. Refer to [IP-11. "Removal and Installation"](#).
6. Disconnect harness from steering column.
7. Remove steering column nuts, then remove steering column assembly.
8. If replacing steering column, remove the following:
 - Remove driver air bag module. Refer to [SR-4. "Removal and Installation"](#).
 - Remove steering wheel. Refer to [ST-7. "Removal and Installation"](#).
 - Remove combination switch.
 - Remove spiral cable. Refer to [SR-7. "Removal and Installation"](#).

INSPECTION AFTER REMOVAL

Hole Cover Seal, Hole Cover, Lower Shaft Assembly

Check each part of hole cover seal, hole cover and steering column, lower shaft and lower joint for damage or other malfunctions. Replace if necessary.

Steering Column Assembly

- Check each part of steering column assembly for damage or other malfunctions. Replace if necessary.
- Measure the length (L) as shown if vehicle has been involved in a minor collision. Replace steering column assembly if outside the specifications.

Steering column length (L)

Telescopic minimum, maximum : Refer to [ST-16. "Steering Column"](#).

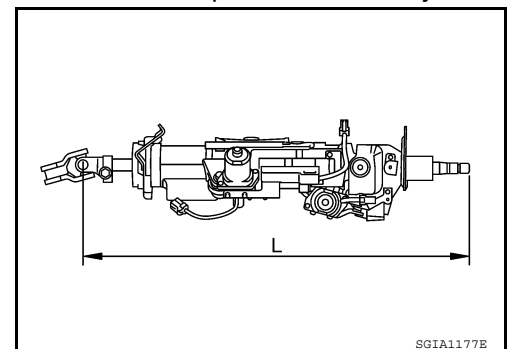

- Measure steering column rotating torque using Tool. Replace steering column assembly if outside the standard.

Tool number : ST3127S000 (J-25765-A)

Rotating torque : Refer to [ST-16. "Steering Column"](#).

STEERING COLUMN

< ON-VEHICLE REPAIR >

- Check tilt and telescopic mechanism operating range (L^1 , L^2) as shown.

Tilt operating range (L^1) and
Telescopic operating range (L^2) : Refer to [ST-16.](#)
["Steering Column"](#).

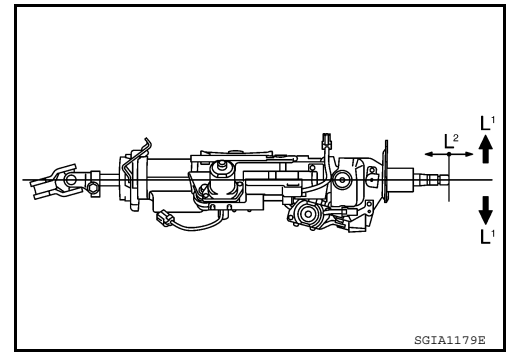

INSTALLATION

Installation is in the reverse order of removal. For tightening specifications, refer to [ST-8. "Exploded View"](#).

- When installing lower shaft assembly to steering gear assembly, follow the procedure listed below.
- Set rack of steering gear in the neutral position.

NOTE:

To get the neutral position of rack, turn gear-sub assembly and measure the distance of inner socket, and then measure the intermediate position of the distance.

- Install slit part (A) of lower shaft assembly joint aligning with the marking position (B) of steering gear assembly input shaft. Make sure that the slit part of lower joint (A) is aligned with the marking position (B) of gear housing assembly input shaft.
- Perform final tightening of nuts and bolts on each part under unladen conditions with tires on level ground when removing steering gear assembly. Check wheel alignment. Refer to [FSU-6. "Inspection and Adjustment"](#).

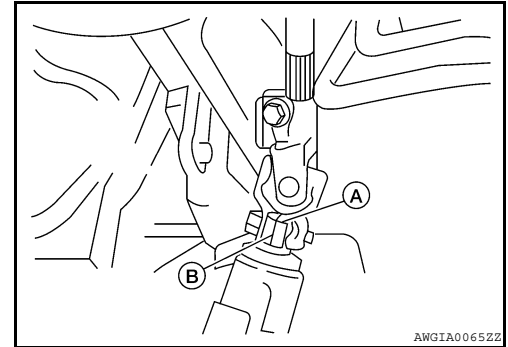

STEERING GEAR AND LINKAGE

< ON-VEHICLE REPAIR >

STEERING GEAR AND LINKAGE

Exploded View

INFOID:000000005440452

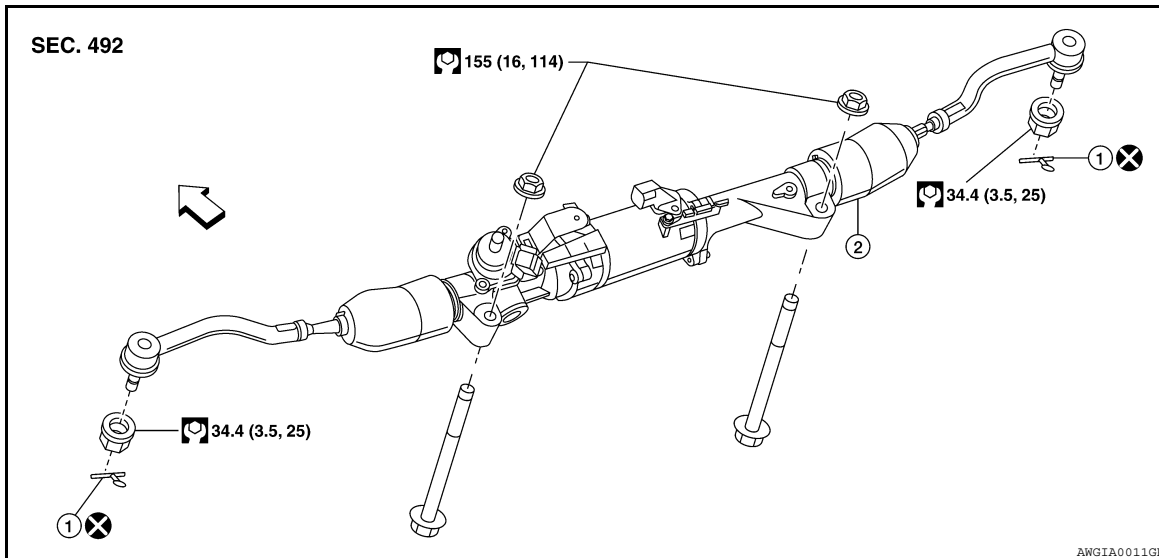

1. Cotter pin

2. Steering gear assembly

← Front

Removal and Installation

INFOID:000000005440453

REMOVAL

1. Remove tires using power tool. Refer to [WT-60, "Adjustment"](#).
2. Remove undercover using power tool.
3. Remove stabilizer bar connecting rods from struts and reposition stabilizer bar.
4. Remove front exhaust tube. Refer to [EX-6, "Removal and Installation"](#).
5. Remove steering column joint pinch bolts.
6. Remove the steering outer socket cotter pin and then loosen the nut.

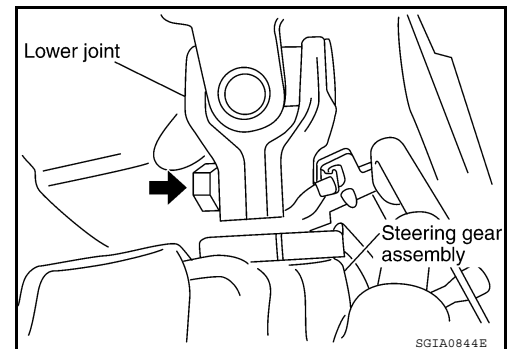

7. Remove steering outer socket from steering knuckle so as not to damage ball joint boot using Tool as shown.

Tool number : HT72520000 (J-25730-A)

CAUTION:

Temporarily tighten the nut to prevent damage to threads and to prevent the Tool from suddenly coming off.

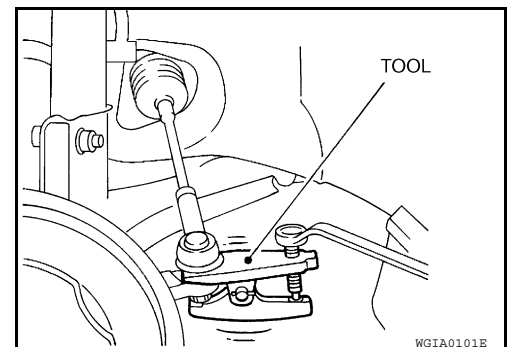

STEERING GEAR AND LINKAGE

< ON-VEHICLE REPAIR >

8. Disconnect EPS torque sensor harness connector (1), EPS motor angle sensor harness connector (2) and EPS motor power line connector (3) from the steering gear (4).

NOTE:

For EPS motor power line connector (3), perform the following;

1. Pull lock plate (5) up until it stops.
2. Turn the lock lever (6) until it stops.
3. Pull EPS motor power line connector (3) to disconnect it.

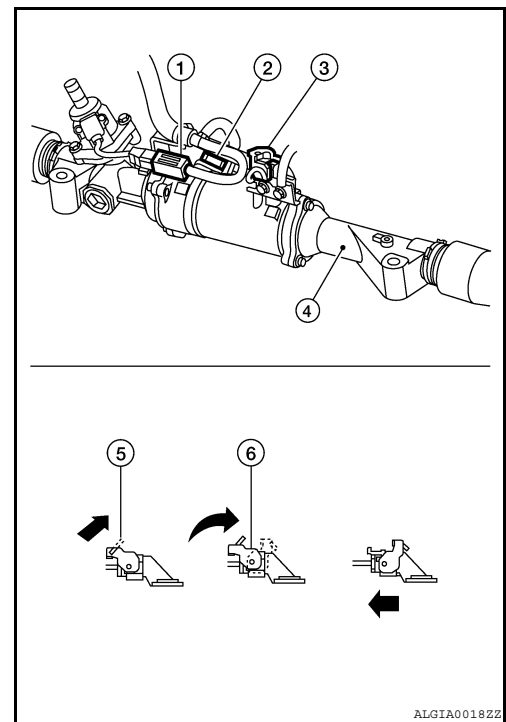

9. Remove ground bracket and harness bracket on steering gear.
10. Remove bolts and nuts of steering gear assembly, and then remove steering gear assembly from vehicle.

INSPECTION AFTER REMOVAL

Check for damage to steering gear. If any exist, replace steering gear as an assembly.

INSTALLATION

Installation is the reverse order of removal. For tightening specifications, refer to [ST-11. "Exploded View"](#).

CAUTION:

After connecting the EPS motor power line connector, make sure the connector is locked.

- When installing lower joint to steering gear assembly, follow the procedure listed below.
 - Set rack of steering gear in the neutral position.

NOTE:

To get the neutral position of rack, turn gear-sub assembly and measure the distance of inner socket, and then measure the intermediate position of the distance.

- Install slit part (A) of lower shaft assembly joint aligning with the marking position (B) of steering gear assembly input shaft. Make sure that the slit part of lower joint (A) is aligned with the marking position (B) of gear housing assembly input shaft.

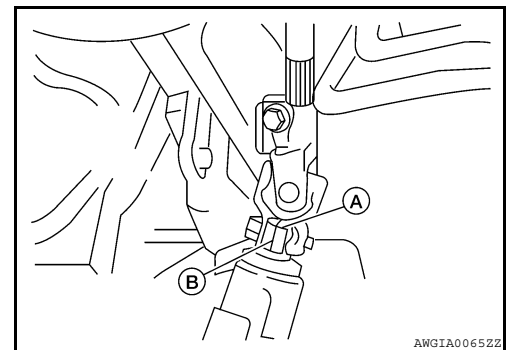

- Perform final tightening of nuts and bolts on each part under unladen conditions with tires on level ground when removing steering gear assembly. Check wheel alignment. Refer to [FSU-6. "Inspection and Adjustment"](#).
- Calibrate EPS. Refer to [STC-5. "EPS MOTOR ANGLE SENSOR INITIALIZATION AND TORQUE SENSOR CALIBRATION : Special Repair Requirement"](#).

INSPECTION AFTER INSTALLATION

Make sure that steering wheel operates smoothly by turning several times from full left stop to full right stop.

STEERING COLUMN

< DISASSEMBLY AND ASSEMBLY >

DISASSEMBLY AND ASSEMBLY

STEERING COLUMN

Disassembly and Assembly

INFOID:000000005809546

CAUTION:

- Any time the ignition switch has been disconnected, removed or installed, the keys must be re-registered in the BCM. Refer to Consult-III operations IVIS/NVIS.

The steering column assembly is not serviceable and must be replaced as an assembly.

A

B

C

D

E

F

ST

H

I

J

K

L

M

N

O

P

STEERING GEAR AND LINKAGE

< DISASSEMBLY AND ASSEMBLY >

STEERING GEAR AND LINKAGE

Exploded View

INFOID:000000005440455

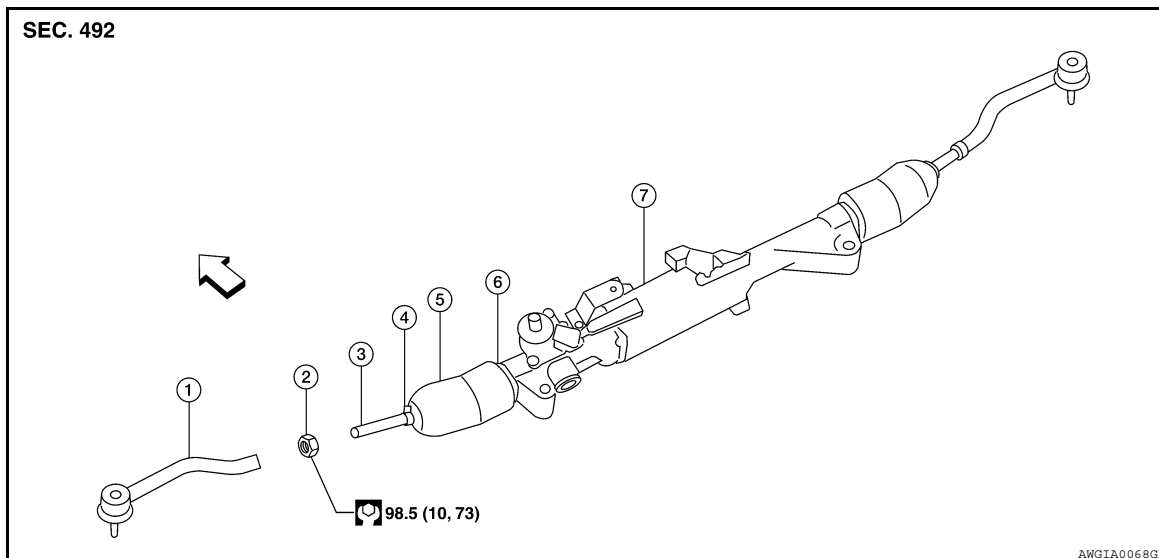

- | | | |
|---------------------|-------------|---------------------|
| 1. Outer socket | 2. Lock nut | 3. Inner socket |
| 4. Small boot clamp | 5. Boot | 6. Large boot clamp |
| 7. Gear assembly | ← Front | |

Disassembly

INFOID:000000005440456

Remove outer socket locknut and outer socket.

NOTE:

Only outer socket can be disassembled. Do not disassemble steering gear assembly.

Inspection

INFOID:000000005440457

INSPECTION AFTER DISASSEMBLY

Boot

Check the boot for cracks and replace as necessary.

Outer Socket and Inner Socket

1. Ball joint swinging torque

- Hook Tool (spring balance) at the hooking position (cotter pin hole) as shown. Pull on Tool (spring balance) and make sure that Tool (spring balance) reads the specified value when outer socket ball stud and inner socket (at measuring point *) start to move. Replace outer socket and steering gear assembly (part of inner socket) if the readings are outside the standard specified value. Refer to [ST-17. "Steering Gear"](#).

Tool number : — (J-44372)

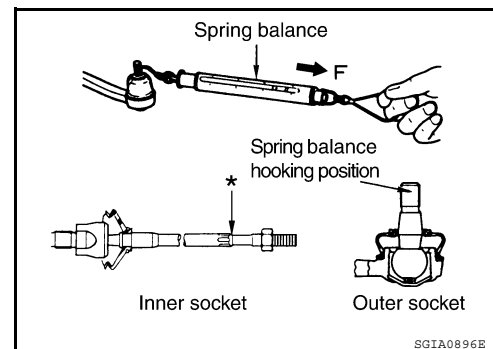

STEERING GEAR AND LINKAGE

< DISASSEMBLY AND ASSEMBLY >

2. Ball joint rotating torque
- Make sure that the reading is within the following specified range using Tool as shown. Replace outer socket if the reading is outside the specified value. Refer to [ST-17. "Steering Gear"](#).

Tool number : ST31227S000 (J-25765-A)

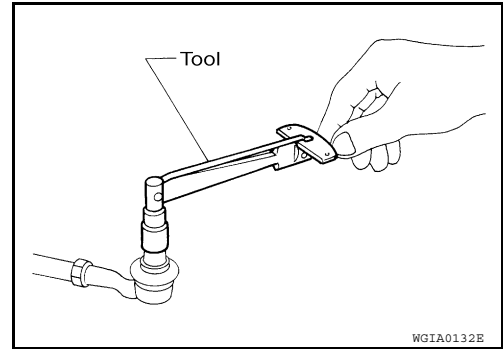

3. Ball joint axial end play
- Apply an axial load of 490 N (50 kg-f, 111 lb-f) to ball stud. Measure amount of stud movement using a dial gauge, and then make sure that the value is within the specified range. Replace outer socket and inner socket if the measured value is outside the standard. Refer to [ST-17. "Steering Gear"](#).

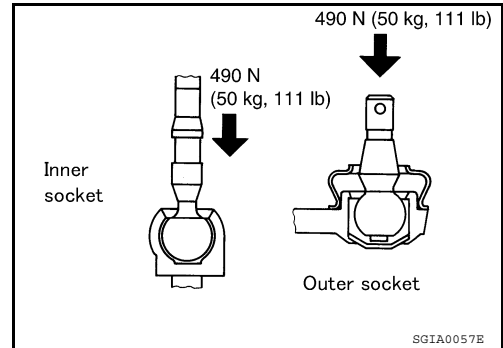

Assembly

Assembly is in the reverse order of disassembly.

- Adjust inner socket to standard length (L), and then tighten lock nut to the specified torque. Refer to [ST-14. "Exploded View"](#). Check length of inner socket (L) again after tightening lock nut. Make sure that the length is the standard.

Inner socket length (L) : Refer to [ST-17. "Steering Gear"](#).

CAUTION:

Adjust toe-in after assembly. Inner socket length achieved after toe-in adjustment should not exceed the maximum specification.

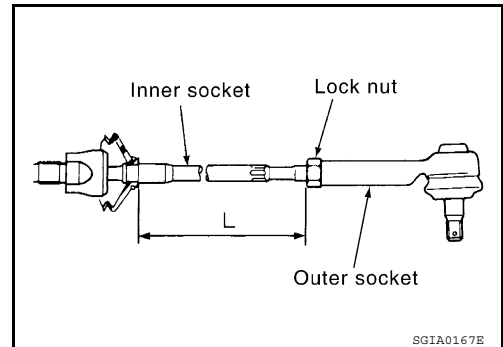

INFOID:000000005440458

SERVICE DATA AND SPECIFICATIONS (SDS)

< SERVICE DATA AND SPECIFICATIONS (SDS)

SERVICE DATA AND SPECIFICATIONS (SDS)

SERVICE DATA AND SPECIFICATIONS (SDS)

Steering Wheel

INFOID:000000005440459

Steering wheel axial end play	0 mm (0 in)
Steering wheel play	0 - 35 mm (0 - 1.38 in)
Steering wheel turning force	39 N (4 kg-f, 9 lb-f) or less

Steering Angle

INFOID:000000005440460

Unit: degree minute (decimal degree)

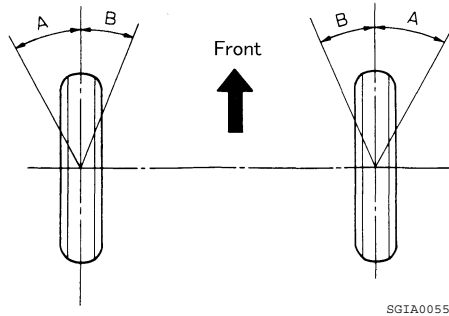

Inner wheel (Angle: A)	Minimum	35° 30' (35.5°)
	Nominal	38° 30' (38.5°)
	Maximum	39° 30' (39.5°)
Outer wheel (Angle: B)	Nominal	31° 30' (31.5°)

Steering Column

INFOID:000000005440461

STEERING COLUMN LENGTH

Unit: mm (in)

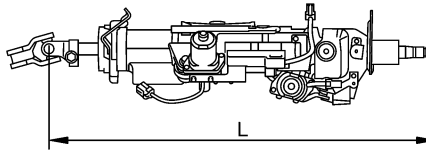

Steering column length (L)	Telescopic maximum	513 - 543 (20.20 - 21.38)
	Telescopic minimum	503 - 513 (19.80 - 20.20)

STEERING COLUMN ROTATING TORQUE

Unit: N·m (kg·m, in·lb)

Steering column rotating torque	0 - 0.2 (0 - 0.2, 0 - 1)
---------------------------------	--------------------------

TILT MECHANISM OPERATING RANGE

SERVICE DATA AND SPECIFICATIONS (SDS)

< SERVICE DATA AND SPECIFICATIONS (SDS)

Unit: mm (in)

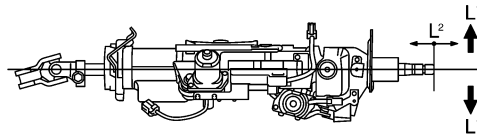

SGIA1179E

Tilt operating range (L ¹)	41 (1.61)
Telescopic operating range (L ²)	40 (1.57)

Steering Gear

INFOID:000000005440462

STEERING OUTER SOCKET AND INNER SOCKET

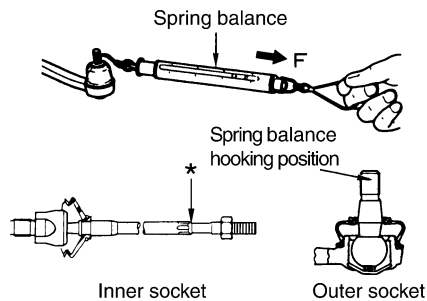

SGIA0896E

Steering gear type		PR26AF
Outer socket	Swinging torque	0.1 - 2.9 N·m (0.01 - 0.29 kg·m, 1.0 - 25 in-lb)
	Measurement on spring balance Measuring point: cotter pin hole of stud	1.4 - 42.7 N (0.14 - 4.4 kg, 0.31 - 9.7 lb)
	Rotating torque	0.3 - 2.9 N·m (0.03 - 0.29 kg·m, 3.0 - 25 in-lb)
	Axial end play	0.5 mm (0.020 in) or less
Inner socket	Swinging torque	0.1 - 7.8 N·m (0.01 - 0.79 kg·m, 1.0 - 69 in-lb)
	<ul style="list-style-type: none"> Measurement on spring balance Measuring point at (* mark shown) 	0.8 - 64 N (0.082 - 6.5 kg, 0.18 - 14.4 lb)
	Axial end play	0.2 mm (0.008 in) or less

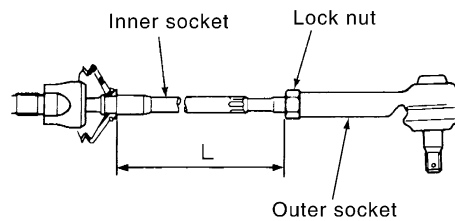

SGIA0167E

Inner socket length (L)	Standard	43.9 mm (1.728 in)
	Maximum	48.9 mm (1.925 in)

SERVICE DATA AND SPECIFICATIONS (SDS)

< SERVICE DATA AND SPECIFICATIONS (SDS)

RACK STROKE

Unit: mm (in)

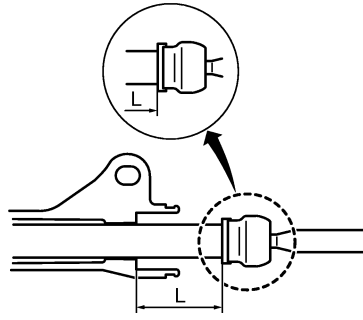

JSGIA0171GB

Steering gear model	PR26AF
Rack neutral position, dimension (L) (rack stroke)	69 (2.72)