

SECTION **CL**
CLUTCH

A
B
C

CL

CONTENTS

E
F
G
H
I
J
K
L
M
N
O
P

SYMPTOM DIAGNOSIS	2	Exploded View	9
NOISE, VIBRATION AND HARSHNESS (NVH) TROUBLESHOOTING	2	Removal and Installation	9
NVH Troubleshooting Chart	2	Inspection	9
PRECAUTION	3	CLUTCH MASTER CYLINDER	10
PRECAUTIONS	3	Removal and Installation	10
Precaution for Supplemental Restraint System (SRS) "AIR BAG" and "SEAT BELT PRE-TENSIONER"	3	CLUTCH PIPING	12
Precaution for Procedure without Cowl Top Cover.....	3	Exploded View	12
Service Notice or Precautions	3	Removal and Installation	12
PREPARATION	5	REMOVAL AND INSTALLATION	13
PREPARATION	5	CSC (CONCENTRIC SLAVE CYLINDER)	13
Special Service Tools	5	Exploded View	13
Commercial Service Tools	5	Removal and Installation	13
ON-VEHICLE MAINTENANCE	6	CLUTCH DISC AND CLUTCH COVER	14
CLUTCH PEDAL	6	Exploded View	14
Inspection and Adjustment	6	Removal and Installation	14
CLUTCH FLUID	7	Inspection	15
Air Bleeding Procedure	7	SERVICE DATA AND SPECIFICATIONS (SDS)	17
ON-VEHICLE REPAIR	9	SERVICE DATA AND SPECIFICATIONS (SDS)	17
CLUTCH PEDAL	9	Clutch Control System	17
		Clutch Pedal	17
		Clutch Disc	17
		Clutch Cover	17

NOISE, VIBRATION AND HARSHNESS (NVH) TROUBLESHOOTING

< SYMPTOM DIAGNOSIS >

SYMPTOM DIAGNOSIS

NOISE, VIBRATION AND HARSHNESS (NVH) TROUBLESHOOTING

NVH Troubleshooting Chart

INFOID:000000005431935

Use the chart below to help you find the cause of the symptom. The numbers indicate the order of the inspection. If necessary, repair or replace these parts.

		Reference page															
		CL-6	CL-7	CL-13	EM-71 (QR25DE), EM-20Z (VQ35DE)	CL-17	CL-15	CL-15	CL-15	CL-15	CL-15	CL-15	CL-14	CL-14	CL-14	EM-75 (QR25DE), EM-212 (VQ35DE)	
		SUSPECTED PARTS (Possible cause)															
		CLUTCH PEDAL (Inspection and adjustment)	CLUTCH LINE (Air in line)	CSC (Concentric slave cylinder) (Worn, dirty or damaged)	ENGINE MOUNTING (Loose)	CLUTCH DISC (Out of true)	CLUTCH DISC (Runout is excessive)	CLUTCH DISC (Lining broken)	CLUTCH DISC (Dirty or burned)	CLUTCH DISC (Oily)	CLUTCH DISC (Worn out)	CLUTCH DISC (Hardened)	CLUTCH DISC (Lack of spline grease)	DIAPHRAGM SPRING (Damaged)	DIAPHRAGM SPRING (Out of tip alignment)	PRESSURE PLATE (Distortion)	FLYWHEEL (Distortion)
Symptom	Clutch grabs/chatters				1		2			2	2	2			2		
	Clutch pedal spongy		1														
	Clutch noisy			1													
	Clutch slips	1								2	2			3		4	5
	Clutch does not disengage	1	2	4		5	5	5	5	5			5	6	6	7	

PRECAUTIONS

< PRECAUTION >

PRECAUTION

PRECAUTIONS

Precaution for Supplemental Restraint System (SRS) "AIR BAG" and "SEAT BELT PRE-TENSIONER"

INFOID:000000005786525

The Supplemental Restraint System such as "AIR BAG" and "SEAT BELT PRE-TENSIONER", used along with a front seat belt, helps to reduce the risk or severity of injury to the driver and front passenger for certain types of collision. This system includes seat belt switch inputs and dual stage front air bag modules. The SRS system uses the seat belt switches to determine the front air bag deployment, and may only deploy one front air bag, depending on the severity of a collision and whether the front occupants are belted or unbelted. Information necessary to service the system safely is included in the SR and SB section of this Service Manual.

WARNING:

- To avoid rendering the SRS inoperative, which could increase the risk of personal injury or death in the event of a collision which would result in air bag inflation, all maintenance must be performed by an authorized NISSAN/INFINITI dealer.
- Improper maintenance, including incorrect removal and installation of the SRS, can lead to personal injury caused by unintentional activation of the system. For removal of Spiral Cable and Air Bag Module, see the SR section.
- Do not use electrical test equipment on any circuit related to the SRS unless instructed to in this Service Manual. SRS wiring harnesses can be identified by yellow and/or orange harnesses or harness connectors.

PRECAUTIONS WHEN USING POWER TOOLS (AIR OR ELECTRIC) AND HAMMERS

WARNING:

- When working near the Airbag Diagnosis Sensor Unit or other Airbag System sensors with the Ignition ON or engine running, DO NOT use air or electric power tools or strike near the sensor(s) with a hammer. Heavy vibration could activate the sensor(s) and deploy the air bag(s), possibly causing serious injury.
- When using air or electric power tools or hammers, always switch the Ignition OFF, disconnect the battery, and wait at least 3 minutes before performing any service.

Precaution for Procedure without Cowl Top Cover

INFOID:000000005431938

When performing the procedure after removing cowl top cover, cover the lower end of windshield with urethane, etc.

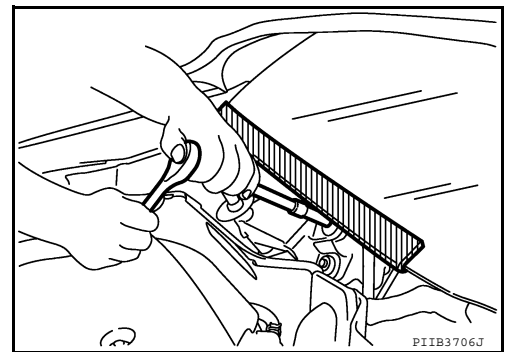

Service Notice or Precautions

INFOID:000000005431939

- Always use recommended fluid. Refer to [MA-15. "FOR USA AND CANADA : Fluids and Lubricants"](#).
- Never reuse drained fluid.
- Be careful not to splash fluid on painted areas.

PRECAUTIONS

< PRECAUTION >

- When removing and installing clutch piping, use tool.
- Use new fluid to clean or wash all parts of master cylinder.
- Never use mineral oils such as gasoline or kerosene. It will ruin the rubber parts of the hydraulic system.

WARNING:

After cleaning clutch disc, wipe it with a dust collector. Do not use compressed air.

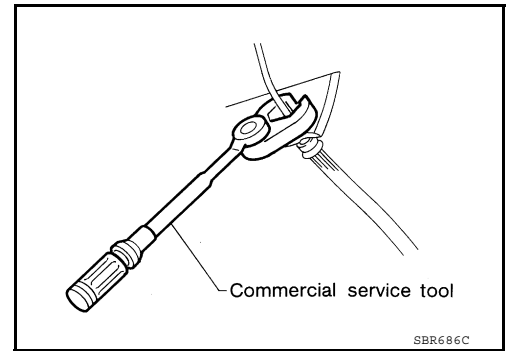

PREPARATION

< PREPARATION >

PREPARATION

PREPARATION

Special Service Tools

INFOID:000000005431940

The actual shapes of Kent-Moore tools may differ from those of special service tools illustrated here.

Tool number (Kent-Moore No.) Tool name	Description
ST20050240 (—) Diaphragm adjusting wrench	Adjusting unevenness of diaphragm spring of clutch cover
KV30101000 (—) Clutch aligning bar	Installing clutch disc a: 15.9 mm (0.626 in) dia. b: 17.9 mm (0.705 in) dia. C: 40 mm (1.57 in) dia.



ZZA0508D

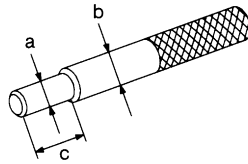

NT405

Commercial Service Tools

INFOID:000000005431941

Tool name	Description
<ol style="list-style-type: none"> Flare nut crowfoot Torque wrench 	Removing and installing clutch piping a: 10 mm (0.39 in)
Power tool	Loosening bolts and nuts

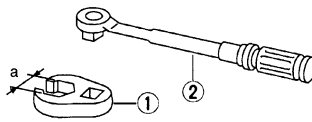

S-NT360

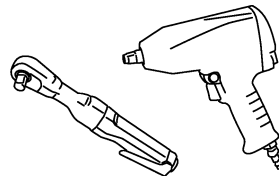

PBIC0190E

CLUTCH PEDAL

< ON-VEHICLE MAINTENANCE >

ON-VEHICLE MAINTENANCE

CLUTCH PEDAL

Inspection and Adjustment

INFOID:000000005431942

1. Check to see if the master cylinder rod end moves freely. It should not be bound by the clutch pedal.
 - If the rod end does not move freely, remove the rod end and check for deformation or damage on the rod end. Leave the rod end removed for step 2.
2. Check the clutch pedal stroke for free range of movement.

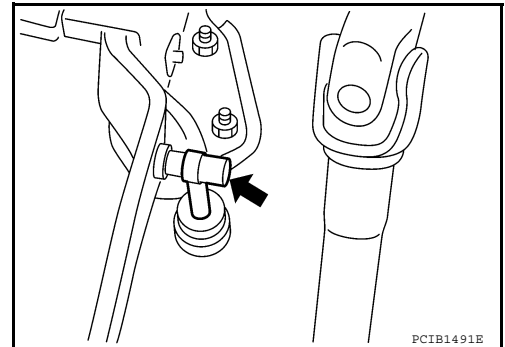

- a. With the master cylinder rod end removed, manually move the clutch pedal up and down to determine if it moves freely.
 - b. If any sticking is noted, replace the clutch pedal assembly. Reverify that the master cylinder rod end moves freely.
3. Inspect the ASCD switch position.
 - a. If the rod end does not move freely, check that the ASCD switch is not applying pressure to the clutch pedal causing the rod end to bind. To adjust, disconnect the ASCD switch electrical connector and turn the ASCD switch.
 - b. Connect the ASCD switch electrical connector.
4. Adjust clutch interlock switch (1) position so that clearance between clutch pedal (2) and thread end of clutch interlock switch (1), with clutch pedal fully depressed, is within specification (C).

Clearance C : 0.74 - 1.96 mm (0.0291 - 0.0772 in)

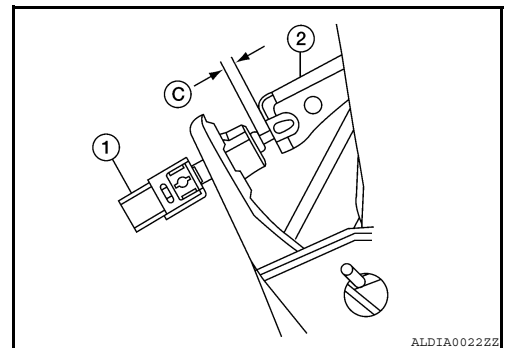

5. Adjust ASCD clutch switch (1) position so that clearance between clutch pedal (2) and thread end of ASCD clutch switch (1), with clutch pedal fully released, is within specification (A).

Clearance A : 0.74 - 1.96 mm (0.0291 - 0.0772 in)

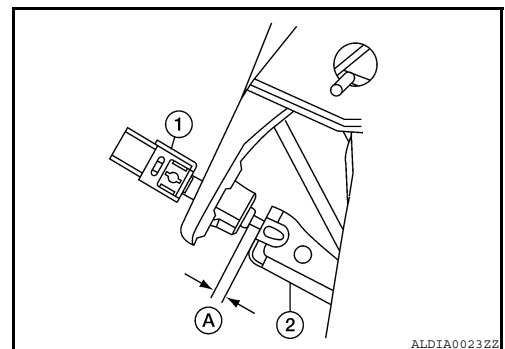

6. Check the clutch hydraulic system components (clutch master cylinder, CSC) for sticking or binding.
- a. If any sticking or binding is noted, repair or replace the related parts as necessary.
- b. If any hydraulic system repair was necessary, bleed the clutch hydraulic system. Refer to [CL-7, "Air Bleeding Procedure"](#).

NOTE:

Do not use a vacuum assist or any other type of power bleeder on this system. Use of a vacuum assist or power bleeder will not purge all of the air from the system.

CLUTCH FLUID

< ON-VEHICLE MAINTENANCE >

CLUTCH FLUID

Air Bleeding Procedure

INFOID:000000005431943

CAUTION:

Do not spill clutch fluid onto painted surfaces. If it spills, wipe up immediately and wash the affected area with water.

NOTE:

- Do not use a vacuum assist or any other type of power bleeder on this system. Use of vacuum assist or power bleeder will not purge all the air from the system.
- Carefully monitor clutch fluid level in reservoir tank during bleeding operation.
- First bleed the air from the bleeding connector on the CSC and then from the air bleed connector valve.

1. Fill master cylinder reservoir tank with new clutch fluid.
2. Connect a transparent vinyl tube and container to the bleeding connector (1) on the CSC.
3. Depress and release the clutch pedal slowly and fully 15 times at an interval of two to three seconds and release the clutch pedal.

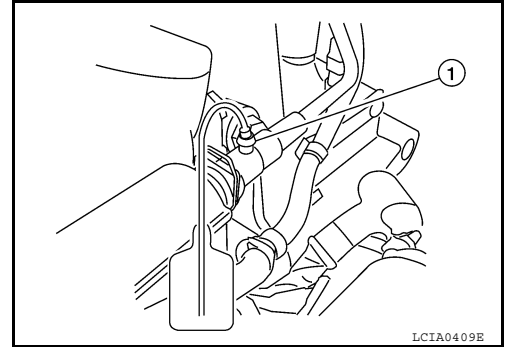

4. Bleed the air from the clutch system according to the following:
 1. Push in the lock pin (1) of the bleeding connector (2), and hold it in.

CAUTION:

Hold the lock pin in to prevent the bleeding connector from separating when fluid pressure is applied.

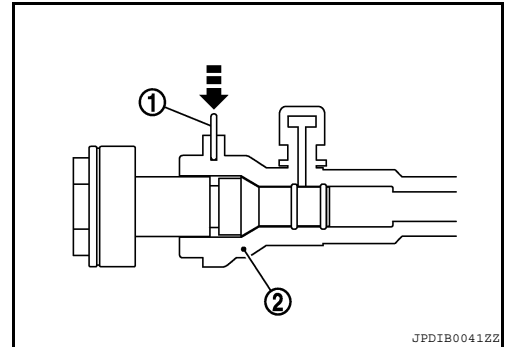

2. Slide the bleeding connector (1) away from the transaxle housing (2) to the specified distance (A) to allow air to bleed from the clutch system.

Dimension (A) : 10 mm (0.39 in)

3. Depress the clutch pedal and hold it down.

CAUTION:

Hold the clutch pedal down to prevent air from getting back into the clutch system.

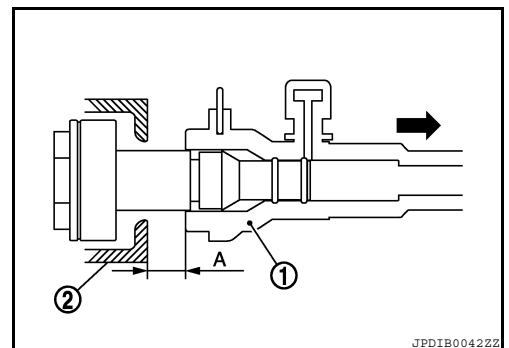

5. Return the bleeding connector and lock pin to their original positions.
6. Release the clutch pedal and wait for five seconds.
7. Repeat steps 3 through 6 until no air bubbles can be observed in the clutch fluid.

CLUTCH FLUID

< ON-VEHICLE MAINTENANCE >

8. Connect a transparent vinyl tube and container to the air bleed connector valve (1).
9. Fully depress the clutch pedal several times.
10. With clutch pedal depressed, open the air bleed connector valve.
11. Close the air bleed connector valve.
12. Release the clutch pedal and wait for five seconds.
13. Repeat steps 9 through 12 until no air bubble can be observed in the clutch fluid.
14. Check clutch fluid level in reservoir tank.

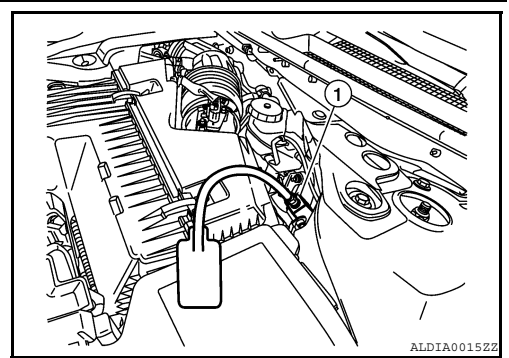

CLUTCH PEDAL

< ON-VEHICLE REPAIR >

ON-VEHICLE REPAIR

CLUTCH PEDAL

Exploded View

INFOID:000000005431944

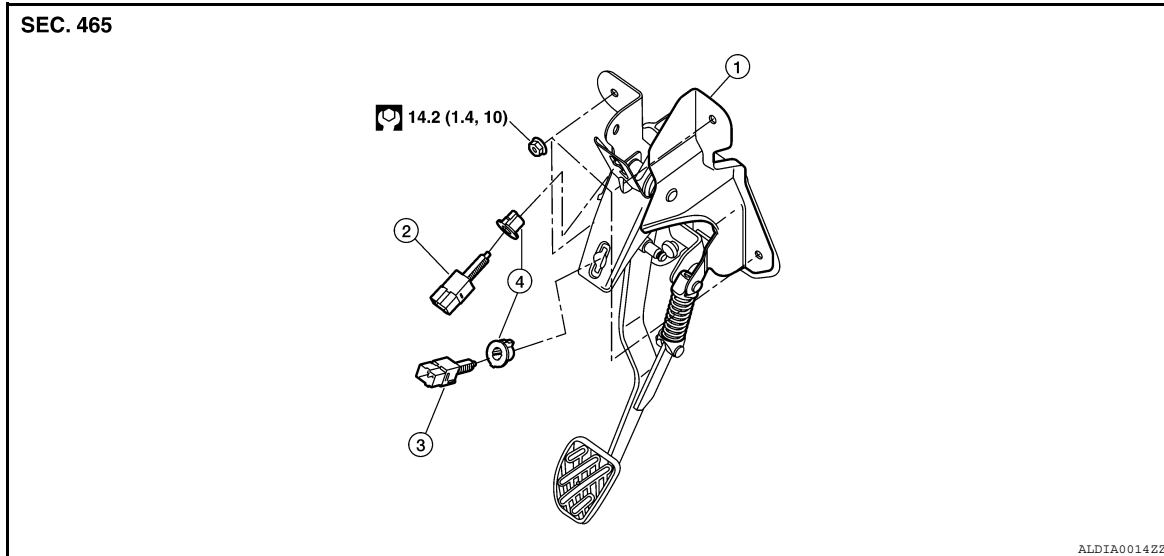

1. Clutch pedal assembly
4. Lock nut

2. Clutch interlock switch

3. ASCD clutch switch

Removal and Installation

INFOID:000000005431945

REMOVAL

1. Disconnect master cylinder rod end from clutch pedal lever.
2. Disconnect the ASCD clutch switch and clutch interlock switch harness connectors.
3. Remove clutch pedal assembly nuts and then remove clutch pedal assembly.

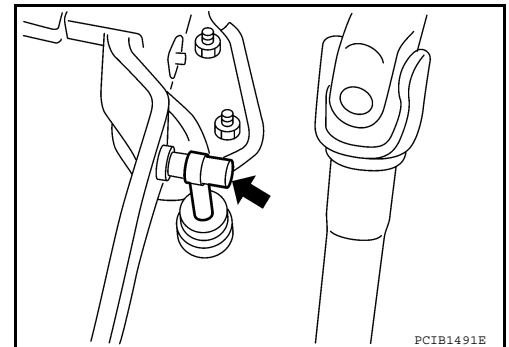

INSTALLATION

Installation is in the reverse order of removal.

- After installing the clutch switches, adjust the switch positions. Refer to [CL-6. "Inspection and Adjustment"](#).

Inspection

INFOID:000000005431946

- After removal, check clutch pedal for bend, damage or a cracked weld. If bend, damage or a cracked weld is found, replace clutch pedal assembly.

CLUTCH MASTER CYLINDER

< ON-VEHICLE REPAIR >

CLUTCH MASTER CYLINDER

Removal and Installation

INFOID:000000005431947

REMOVAL

1. Remove cowl top. Refer to [EXT-19, "Removal and Installation"](#) (Coupe models) or [EXT-41, "Removal and Installation"](#) (Sedan models).
2. Remove engine room cover.
3. Remove the air cleaner and air duct. Refer to [EM-19, "Removal and Installation"](#) (QR25DE models) or [EM-123, "Removal and Installation"](#) (VQ35DE models).
4. Use one of the following methods to remove hose from master cylinder.
 - Drain clutch fluid from reservoir tank and remove hose.
 - Remove hose from master cylinder. Immediately plug hose and reservoir tank to prevent clutch fluid from dripping.

CAUTION:

Do not spill clutch fluid onto painted surfaces. If it spills, wipe up immediately and wash the affected area with water.

5. Remove master cylinder rod end from clutch pedal assembly.

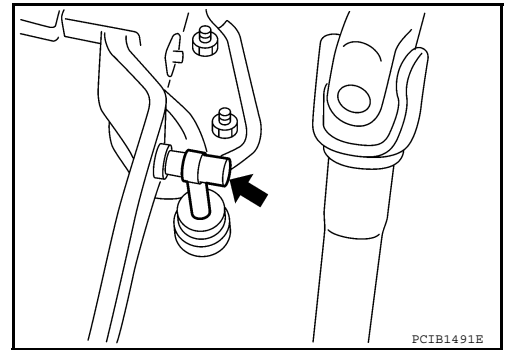

6. Remove lock pin (1) from connector of master cylinder (2) and separate clutch tube (3).

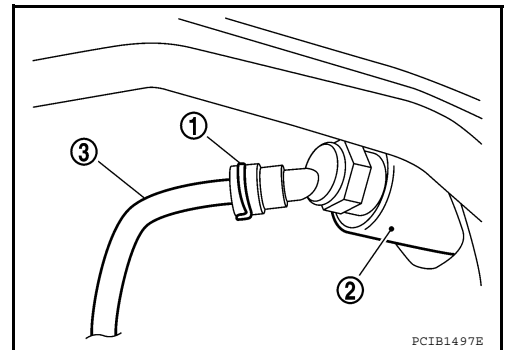

7. Rotate master cylinder clockwise by 45° and remove from the vehicle.

INSTALLATION

1. Tilt master cylinder clockwise by 45° and insert it in the mounting hole. Rotate counterclockwise to secure it. At this time, nipple is in the up position.
2. Install master cylinder rod end to clutch pedal.

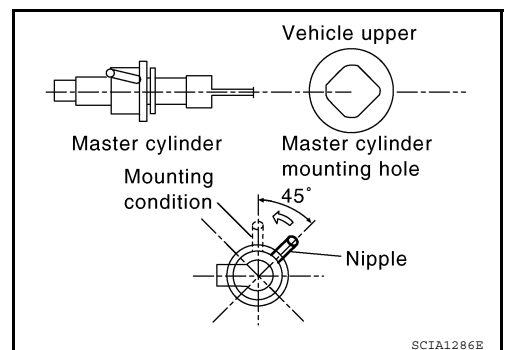

CLUTCH MASTER CYLINDER

< ON-VEHICLE REPAIR >

3. Install clutch tube (1) fully into connector of master cylinder (2).
4. Install lock pin (3) fully into connector of master cylinder (2).
5. Fill with new clutch fluid and bleed clutch hydraulic system. Refer to [CL-6, "Inspection and Adjustment"](#).
6. Inspect clutch pedal operation. Refer to [CL-6, "Inspection and Adjustment"](#).
7. Install the air cleaner and air duct. Refer to [EM-19, "Removal and Installation"](#) (QR25DE models) or [EM-123, "Removal and Installation"](#) (VQ35DE models).
8. Install engine room cover.
9. Install cowl top. Refer to [EXT-19, "Removal and Installation"](#) (Coupe models) or [EXT-41, "Removal and Installation"](#) (Sedan models).

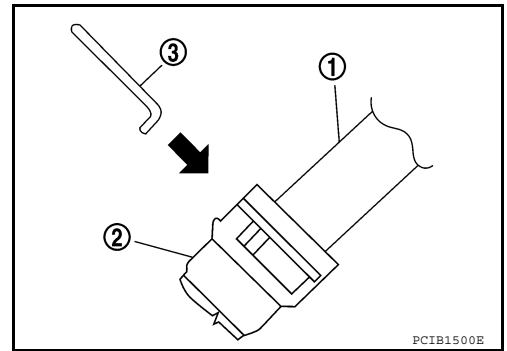

A
B
C
CL

E
F
G
H
I
J
K
L
M
N
O
P

CSC (CONCENTRIC SLAVE CYLINDER)

< REMOVAL AND INSTALLATION >

REMOVAL AND INSTALLATION

CSC (CONCENTRIC SLAVE CYLINDER)

Exploded View

INFOID:000000005431950

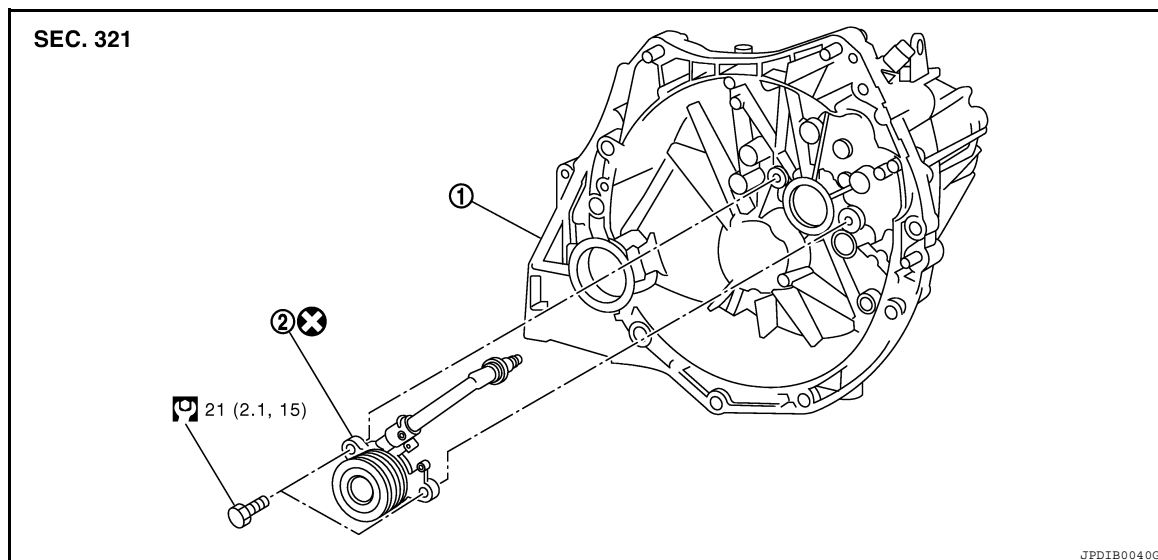

1. Transaxle assembly
2. CSC (Concentric Slave Cylinder)

Removal and Installation

INFOID:000000005431951

CAUTION:

- If transaxle assembly is removed from the vehicle, always replace CSC. Return CSC insert to original position to remove transaxle assembly. Dust on clutch disc sliding parts may damage CSC seal and may cause clutch fluid leakage.
- Do not spill clutch fluid onto painted surfaces. If it spills, wipe up immediately and wash the affected area with water.

REMOVAL

1. Remove the engine and transaxle assembly. Refer to [EM-71, "Removal and Installation"](#) (QR25DE models) or [EM-207, "Removal and Installation"](#) (VQ35DE models).
2. Separate transaxle from engine.
3. Remove CSC bolts and CSC from clutch housing.

INSTALLATION

Installation is in the reverse order of removal.

CAUTION:

- Do not reuse CSC.
- Do not insert and operate CSC because piston and stopper of CSC components may fall off.

After installation, bleed clutch hydraulic system. Refer to [CL-7, "Air Bleeding Procedure"](#).

CLUTCH DISC AND CLUTCH COVER

< REMOVAL AND INSTALLATION >

- If flywheel is removed, align dowel pin with the smallest hole of flywheel (VQ35DE models). Refer to [EM-212, "Disassembly and Assembly"](#).
- Replace clutch disc and clutch cover as a set (VQ35DE models).

REMOVAL

1. Remove the engine and transaxle assembly. Refer to [TM-27, "Removal and Installation"](#).
2. Separate the transaxle from the engine.
3. Loosen clutch cover bolts evenly. Then remove clutch cover and clutch disc.

INSTALLATION

1. Clean clutch disc and input shaft splines to remove grease and dust caused by abrasion.
2. Apply recommended grease to clutch disc and input shaft splines.

CAUTION:

Be sure to apply grease to the points specified. Otherwise, noise, poor disengagement, or damage to the clutch may result. Excessive grease may cause slip or shudder. If it adheres to CSC seal, it will cause clutch fluid leakage. Wipe off excess grease.

3. Install clutch disc using Tool.

Tool number : KV30101000 (—)

4. Install clutch cover. Pre-tighten clutch cover bolts.
5. Tighten clutch cover bolts evenly in two steps in the order shown. Refer to [CL-14, "Exploded View"](#).
6. Install engine and transaxle assembly. Refer to [TM-27, "Removal and Installation"](#).

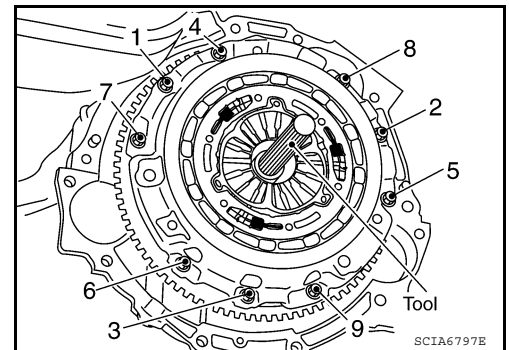

Inspection

CLUTCH DISC

- Measure clutch disc runout and backlash. If either measurement exceeds the specification, replace clutch disc (QR25DE models) or clutch disc and clutch cover as a set (VQ35DE models).

Runout and backlash : Refer to [CL-17, "Clutch Disc"](#).

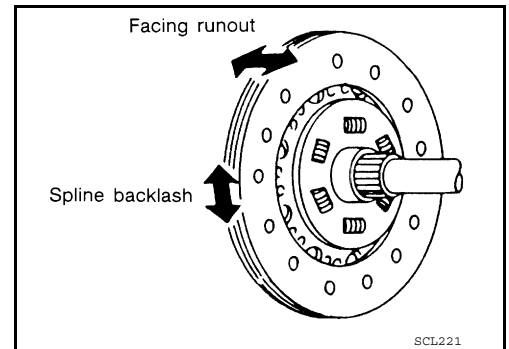

- Check clutch disc for burns, discoloration or oil or grease leakage. Replace if necessary.
- Determine the clutch facing wear limit (depth to the rivet head). If measurement exceeds specifications, replace clutch disc (QR25DE models) or clutch disc and clutch cover as a set (VQ35DE models).

Clutch facing wear : Refer to [CL-17, "Clutch Disc"](#).

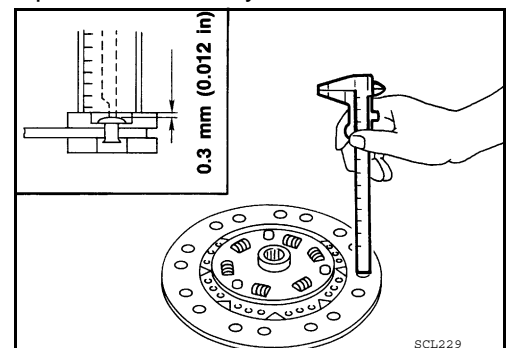

CLUTCH COVER

CLUTCH DISC AND CLUTCH COVER

< REMOVAL AND INSTALLATION >

- Check clutch cover installed on vehicle for unevenness of diaphragm spring toe height. If unevenness exceeds specifications, adjust the height using Tool (A).

Uneven limit of diaphragm spring toe height : Refer to [CL-17, "Clutch Cover"](#).

Tool number : ST20050240 (—)

- Check clutch cover thrust ring for wear or breakage. If wear or breakage is found, replace clutch cover (QR25DE models) or clutch disc and clutch cover as a set (VQ35DE models).

NOTE:

- Worn thrust ring will generate a beating noise when tapped at the rivet using suitable tool.
- Broken thrust ring will make a clinking sound when cover is shaken up and down.
- If a trace of burn or discoloration is found on clutch cover pressure plate to clutch disc contact surface, repair the surface with sandpaper. If surface is damaged or distorted, replace clutch cover (QR25DE models) or clutch disc and clutch cover as a set (VQ35DE models).

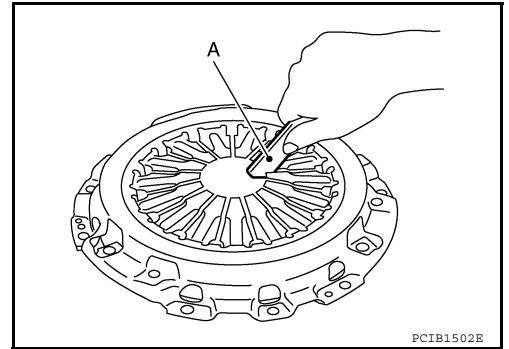

SERVICE DATA AND SPECIFICATIONS (SDS)

< SERVICE DATA AND SPECIFICATIONS (SDS)

SERVICE DATA AND SPECIFICATIONS (SDS)

SERVICE DATA AND SPECIFICATIONS (SDS)

Clutch Control System

INFOID:000000005431955

Type of clutch control	Hydraulic
------------------------	-----------

Clutch Pedal

INFOID:000000005431956

Unit: mm (in)

Clearance between clutch pedal and ASCD switch threaded end while clutch pedal is fully released.	0.74 - 1.96 (0.0291 - 0.0772)
Clearance between clutch pedal and clutch interlock switch threaded end while clutch pedal is fully depressed.	0.74 - 1.96 (0.0291 - 0.0772)

Clutch Disc

INFOID:000000005431957

Unit: mm (in)

Engine model	QR25DE	VQ35DE
Model	240	
Facing size (Outer dia. × Inner dia. × Thickness)	240 × 160 × 8.0 (9.45 × 6.30 × 0.31)	240 × 160 × 8.4 (9.45 × 6.30 × 0.33)
Thickness of disc assembly with load	7.15 - 7.65 (0.2815 - 0.3012) with 6,370 N (649.7 kg, 1,432.0 lb)	7.6 - 8.0 (0.299 - 0.31) with 9,900 N (1,009.8 kg, 2,225.5 lb)
Runout limit/diameter of the area to be measured	0.7 (0.028) or less / 230 (9.06) dia.	1.0 (0.039) or less / 230 (9.06) dia.
Maximum spline backlash (at outer edge disc)	1.0 (0.039)	
Wear limit (depth to the rivet head)	0.3 (0.012)	

Clutch Cover

INFOID:000000005431958

Unit: mm (in)

Engine model	QR25DE	VQ35DE
Set-load	6,370 N (649.7 kg, 1432.0 lb)	9,900 N (1,009.8 kg, 2,225.5 lb)
Diaphragm spring lever height	28.6 - 30.6 (1.126 - 1.205)	41.6 - 43.8 (1.638 - 1.724)
Uneven limit of diaphragm spring toe height	0.7 (0.028) or less	0.8 (0.031) or less