

SECTION **FAX**
FRONT AXLE

A
B
C

FAX

CONTENTS

E

PRECAUTION	2	ON-VEHICLE REPAIR	7	F
PRECAUTIONS	2	FRONT WHEEL HUB AND KNUCKLE	7	G
Precaution for Supplemental Restraint System (SRS) "AIR BAG" and "SEAT BELT PRE-TENSIONER"	2	Removal and Installation	7	
General Precautions	2	FRONT DRIVE SHAFT	9	H
SYMPTOM DIAGNOSIS	3	Removal and Installation (Left Side)	9	
NOISE, VIBRATION, AND HARSHNESS (NVH) TROUBLESHOOTING	3	Removal and Installation (Right Side)	10	
NVH Troubleshooting Chart	3	DISASSEMBLY AND ASSEMBLY	13	I
PREPARATION	4	FRONT DRIVE SHAFT	13	J
PREPARATION	4	Disassembly and Assembly (Left Side)	13	
Special Service Tool	4	Disassembly and Assembly (Right Side)	18	
Commercial Service Tool	4	SERVICE DATA AND SPECIFICATIONS (SDS)	25	K
ON-VEHICLE MAINTENANCE	5	SERVICE DATA AND SPECIFICATIONS (SDS)	25	L
FRONT WHEEL HUB	5	Wheel Bearing	25	
Inspection	5	Drive Shaft	25	
FRONT DRIVE SHAFT	6	Dynamic Damper	25	M
Inspection	6	Boot Bands	26	

N
O
P

PRECAUTIONS

< PRECAUTION >

PRECAUTION

PRECAUTIONS

Precaution for Supplemental Restraint System (SRS) "AIR BAG" and "SEAT BELT PRE-TENSIONER"

INFOID:000000005786167

The Supplemental Restraint System such as "AIR BAG" and "SEAT BELT PRE-TENSIONER", used along with a front seat belt, helps to reduce the risk or severity of injury to the driver and front passenger for certain types of collision. This system includes seat belt switch inputs and dual stage front air bag modules. The SRS system uses the seat belt switches to determine the front air bag deployment, and may only deploy one front air bag, depending on the severity of a collision and whether the front occupants are belted or unbelted. Information necessary to service the system safely is included in the SR and SB section of this Service Manual.

WARNING:

- **To avoid rendering the SRS inoperative, which could increase the risk of personal injury or death in the event of a collision which would result in air bag inflation, all maintenance must be performed by an authorized NISSAN/INFINITI dealer.**
- **Improper maintenance, including incorrect removal and installation of the SRS, can lead to personal injury caused by unintentional activation of the system. For removal of Spiral Cable and Air Bag Module, see the SR section.**
- **Do not use electrical test equipment on any circuit related to the SRS unless instructed to in this Service Manual. SRS wiring harnesses can be identified by yellow and/or orange harnesses or harness connectors.**

PRECAUTIONS WHEN USING POWER TOOLS (AIR OR ELECTRIC) AND HAMMERS

WARNING:

- **When working near the Airbag Diagnosis Sensor Unit or other Airbag System sensors with the Ignition ON or engine running, DO NOT use air or electric power tools or strike near the sensor(s) with a hammer. Heavy vibration could activate the sensor(s) and deploy the air bag(s), possibly causing serious injury.**
- **When using air or electric power tools or hammers, always switch the Ignition OFF, disconnect the battery, and wait at least 3 minutes before performing any service.**

General Precautions

INFOID:000000005430057

Observe the following precautions when disassembling and assembling drive shaft.

- Joint sub-assembly does not disassemble because it is non-overhaul parts.
- Perform work in a location which is as dust-free as possible.
- Before disassembling and assembling, clean the outside of parts.
- Prevention of the entry of foreign objects must be taken into account during disassembly of the service location.
- Disassembled parts must be carefully reassembled in the correct order. If work is interrupted, a clean cover must be placed over parts.
- Paper shop cloths must be used. Fabric shop cloths must not be used because of the danger of lint adhering to parts.
- Disassembled parts (except for rubber parts) should be cleaned with kerosene which shall be removed by blowing with air or wiping with paper shop cloths.

NOISE, VIBRATION, AND HARSHNESS (NVH) TROUBLESHOOTING

< SYMPTOM DIAGNOSIS >

SYMPTOM DIAGNOSIS

NOISE, VIBRATION, AND HARSHNESS (NVH) TROUBLESHOOTING

NVH Troubleshooting Chart

INFOID:000000005430054

Use chart below to help you find the cause of the symptom. If necessary, repair or replace these parts.

Reference page			Possible cause and SUSPECTED PARTS												
			Excessive joint angle	Joint sliding resistance	Imbalance	Improper installation, looseness	Parts interference	Wheel bearing damage	SUSPENSION	FRONT AXLE	TIRES	ROAD WHEEL	DRIVE SHAFT	BRAKES	STEERING
Symptom	DRIVE SHAFT	Noise	x	x					x	x	x	x		x	x
		Shake	x		x				x	x	x	x		x	x
	FRONT AXLE	Noise				x	x		x		x	x	x	x	x
		Shake				x	x		x		x	x	x	x	x
		Vibration				x	x		x		x		x		x
		Shimmy				x	x		x		x	x		x	x
		Shudder				x			x		x	x		x	x
		Poor quality ride or handling				x	x	x	x		x	x			

x: Applicable

A
B
C
D
E
F
G
H
I
J
K
L
M
N
O
P

FAX

PREPARATION

< PREPARATION >



PREPARATION

PREPARATION

Special Service Tool

INFOID:000000005430058

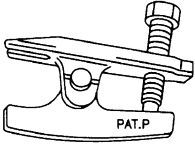
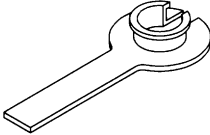
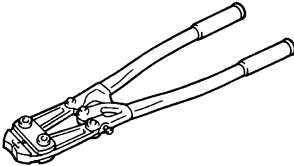
The actual shapes of Kent-Moore tools may differ from those of special service tools illustrated here.

Tool number (Kent-Moore No.) Tool name		Description
HT72520000 (J-25730-A) Ball joint remover	 <small>PAT.P</small> <small>NT146</small>	Removing outer tie-rod
KV38106700 (J-34296) KV38106800 (J-34297) Differential side oil seal protector	 <small>NT147</small>	Installing drive shaft LH: KV38106700 (J-34296) RH: KV38106800 (J-34297)
KV40107300 (—) Boot Band crimping tool	 <small>ZZA1229D</small>	Installing boot bands
KV40107500 (—) Drive shaft attachment	 <small>ZZA1230D</small>	Removing drive shaft

Commercial Service Tool

INFOID:000000005430059

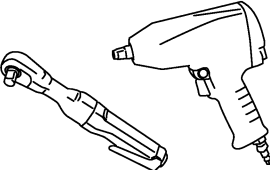
Tool name		Description
Power tool	 <small>PBIC0190E</small>	Removing nuts and bolts

FRONT WHEEL HUB

< ON-VEHICLE MAINTENANCE >

ON-VEHICLE MAINTENANCE

FRONT WHEEL HUB

Inspection

INFOID:000000005430060

- Move wheel hub and bearing assembly in the axial direction by hand. Make sure there is no looseness of wheel bearing.

Axial end play : 0.05 mm (0.002 in) or less

- Rotate wheel hub and make sure that is no unusual noise or other irregular conditions. If there is any of irregular conditions, replace wheel hub and bearing assembly

A

B

C

FAX

E

F

G

H

I

J

K

L

M

N

O

P

FRONT DRIVE SHAFT

< ON-VEHICLE MAINTENANCE >

FRONT DRIVE SHAFT

Inspection

INFOID:000000005430061

- Check drive shaft mounting point and joint for looseness and other damage.
- Check boot for cracks and other damage.

CAUTION:

Replace entire drive shaft assembly when noise or vibration occur from drive shaft.

FRONT WHEEL HUB AND KNUCKLE

< ON-VEHICLE REPAIR >

ON-VEHICLE REPAIR

FRONT WHEEL HUB AND KNUCKLE

Removal and Installation

INFOID:000000005430062

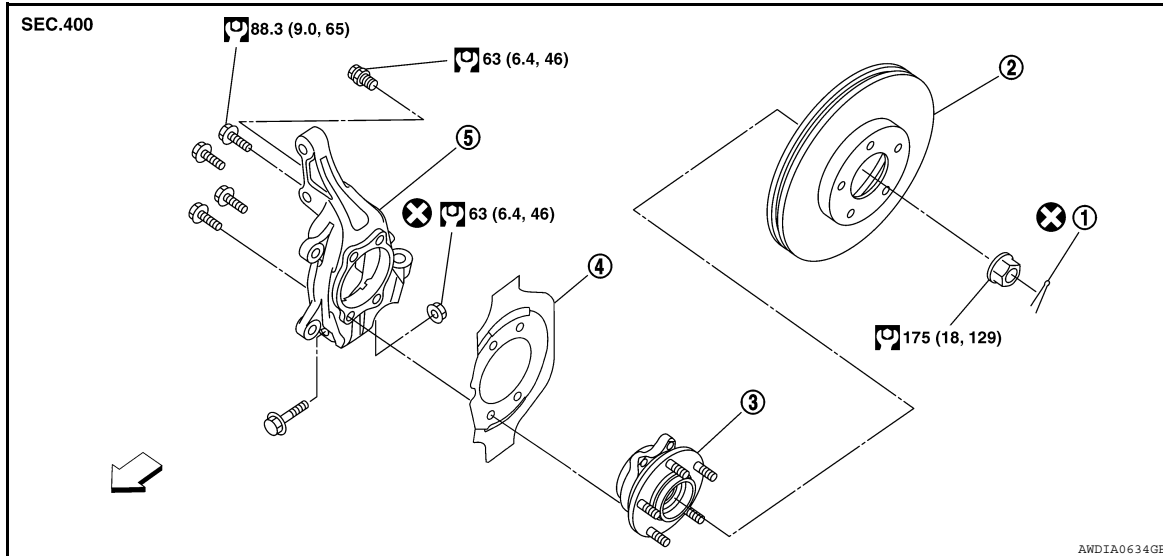

- | | | |
|-----------------|---------------------|-----------------------------------|
| 1. Cotter pin | 2. Disc rotor | 3. Wheel hub and bearing assembly |
| 4. Splash guard | 5. Steering knuckle | ⇐ Front |

REMOVAL

1. Remove wheel and tire from vehicle. Refer to [WT-65. "Adjustment"](#).
2. Remove brake caliper using power tool, leaving brake caliper hydraulic lines connected. Reposition brake caliper aside with wire. Refer to [BR-30. "BRAKE CALIPER ASSEMBLY : Exploded View"](#).

NOTE:

Avoid depressing brake pedal while brake caliper is removed.

3. Put alignment marks on disc rotor and wheel hub and bearing assembly, then remove disc rotor.
4. Remove wheel sensor from steering knuckle. Refer to [BRC-57. "Removal and Installation"](#) (ABS), [BRC-163. "Removal and Installation"](#) (VDC/TCS/ABS).

CAUTION:

Do not pull on wheel sensor harness.

5. Remove cotter pin, then remove lock nut from drive shaft using power tool.
6. Remove steering outer tie-rod cotter pin at steering knuckle, then loosen nut using power tool. Refer to [ST-16. "Removal and Installation"](#).

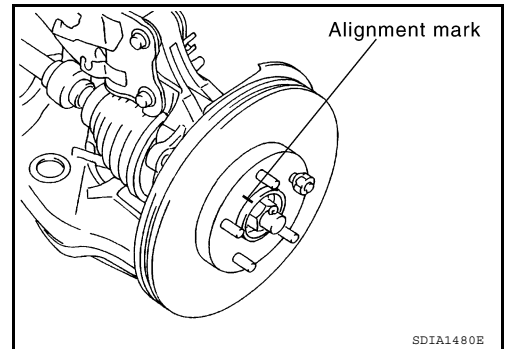

7. Disconnect the outer tie-rod end from steering knuckle using Tool. Be careful not to damage ball joint boot.

CAUTION:

To prevent damage to threads and to prevent Tool from coming off suddenly, temporarily tighten mounting nut.

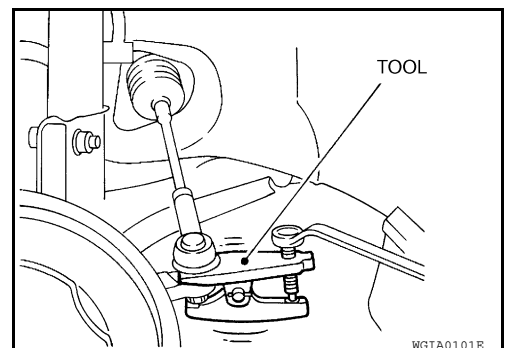

Tool number : HT72520000 (J-25730-A)

FRONT WHEEL HUB AND KNUCKLE

< ON-VEHICLE REPAIR >

8. Remove transverse link and steering knuckle pinch bolt and nut using power tool. Refer to [FSU-12. "Exploded View"](#).
9. Remove wheel hub and bearing assembly from drive shaft using a puller or suitable tool.

CAUTION:

- When removing wheel hub and bearing assembly, do not apply an excessive angle to drive shaft joint. Also be careful not to excessively extend slide joint.
- Support drive shaft when removing.

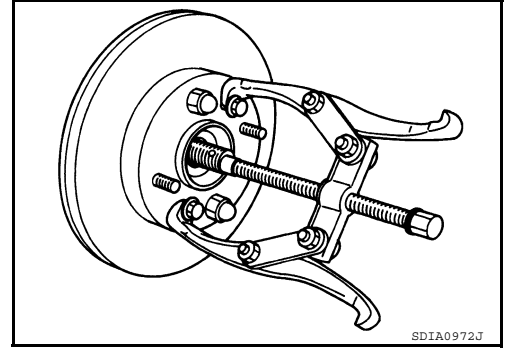

10. Remove wheel hub and bearing assembly bolts using power tool.
11. Remove splash guard and wheel hub and bearing assembly from steering knuckle.
12. Remove the lower strut bolts and nuts using power tool. Refer to [FSU-12. "Exploded View"](#).
13. Remove steering knuckle from vehicle.

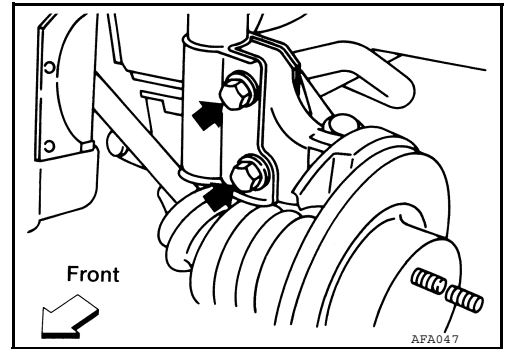

INSPECTION AFTER REMOVAL

Check for deformity, cracks and damage on each part, replace if necessary.

Ball Joint Inspection

- Check for boot breakage, axial looseness, and torque of transverse link ball joint and repair as necessary.

INSTALLATION

Installation is in the reverse order of removal.

CAUTION:

Do not reuse non-reusable parts.

- When installing wheel hub and bearing assembly to steering knuckle, align cutout in toner ring cover with wheel sensor mounting hole in steering knuckle.
- When installing disc rotor on wheel hub and bearing assembly, align the marks.
(When not using the alignment mark, refer to [BR-7. "DISC ROTOR : Inspection"](#).)

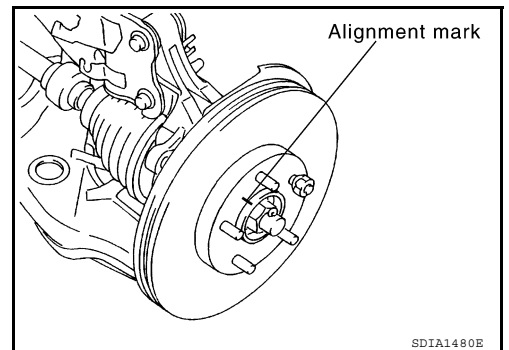

FRONT DRIVE SHAFT

< ON-VEHICLE REPAIR >

FRONT DRIVE SHAFT

Exploded View

INFOID:000000005825197

LEFT SIDE

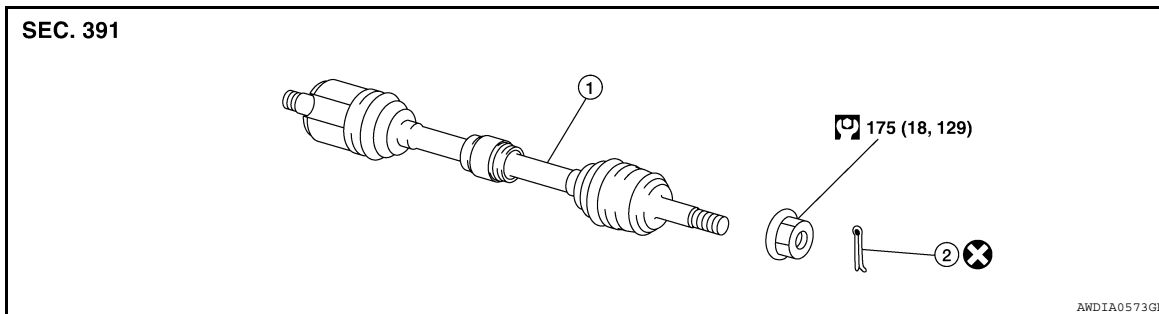

1. Drive shaft
2. Cotter pin

Removal and Installation (Left Side)

INFOID:000000005786169

REMOVAL

1. Remove wheel and tire using power tool.
2. Remove wheel sensor from steering knuckle. Refer to [BRC-57, "Removal and installation"](#) (ABS), [BRC-163, "Removal and installation"](#) (VDC/TCS/ABS).
3. Remove cotter pin. Then remove lock nut from drive shaft.
4. Remove brake hose lock plate. Then remove brake hose from strut.
5. Remove brake caliper using power tool, leaving hydraulic line attached. Hang caliper aside using wire. Refer to [BR-31, "BRAKE CALIPER ASSEMBLY: Removal and Installation"](#).
6. Remove front strut to steering knuckle bolts and nuts, then separate steering knuckle from strut. Refer to [FSU-8, "Removal and Installation"](#).
7. Remove drive shaft from wheel hub and bearing assembly, using a puller or suitable tool.

CAUTION:

- When removing drive shaft, do not apply an excessive angle to drive shaft joint. Also be careful not to excessively extend slide joint.

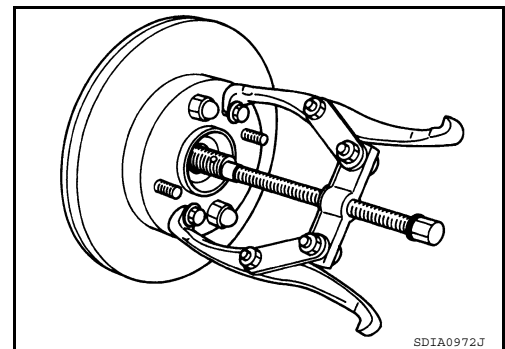

8. Remove the left hand drive shaft from the transaxle.
 - Remove drive shaft from transaxle using Tool and drive shaft puller or suitable tool.
 - Set Tool and a drive shaft puller or suitable tool between drive shaft (slide joint side) and transaxle as shown, then remove drive shaft.

Tool number : KV40107500 (—)

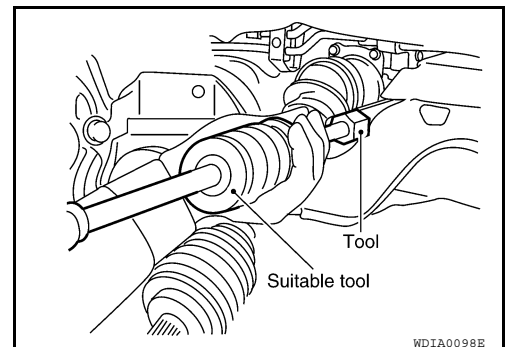

INSPECTION AFTER REMOVAL

- Move joint up/down, left/right, and in axial direction. Check for any rough movement or significant looseness.

A
B
C
FAX
E
F
G
H
I
J
K
L
M
N
O
P

FRONT DRIVE SHAFT

< ON-VEHICLE REPAIR >

- Check boot for cracks or other damage, and for grease leakage.
- If damaged, disassemble drive shaft to verify damage, and repair or replace as necessary.

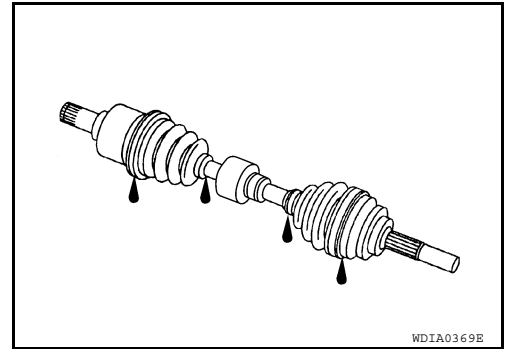

INSTALLATION

Installation is in the reverse order of removal.

CAUTION:

Do not reuse non-reusable parts.

- Tighten the drive shaft lock nut to specification. Refer to [FAX-9, "Exploded View"](#).
- In order to prevent damage to differential side oil seal, place Tool (A) onto oil seal before inserting drive shaft as shown. Slide drive shaft into slide joint and tap with a hammer to install securely.

Tool number : KV38106700 (J-34296)

- Install new circlip on drive shaft in the circular clip groove on transaxle side. Refer to [FAX-13, "Disassembly and Assembly \(Left Side\)"](#).

CAUTION:

Make sure the new circlip on the drive shaft is securely fastened.

- After its insertion, try to pull the flange out of the slide joint by hand. If it pulls out, the circlip is not properly meshed with the transaxle side gear.

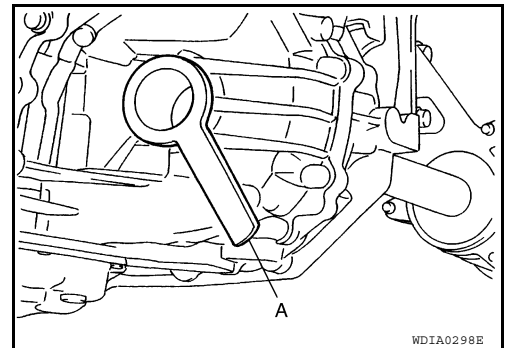

Exploded View

INFOID:000000005825196

RIGHT SIDE

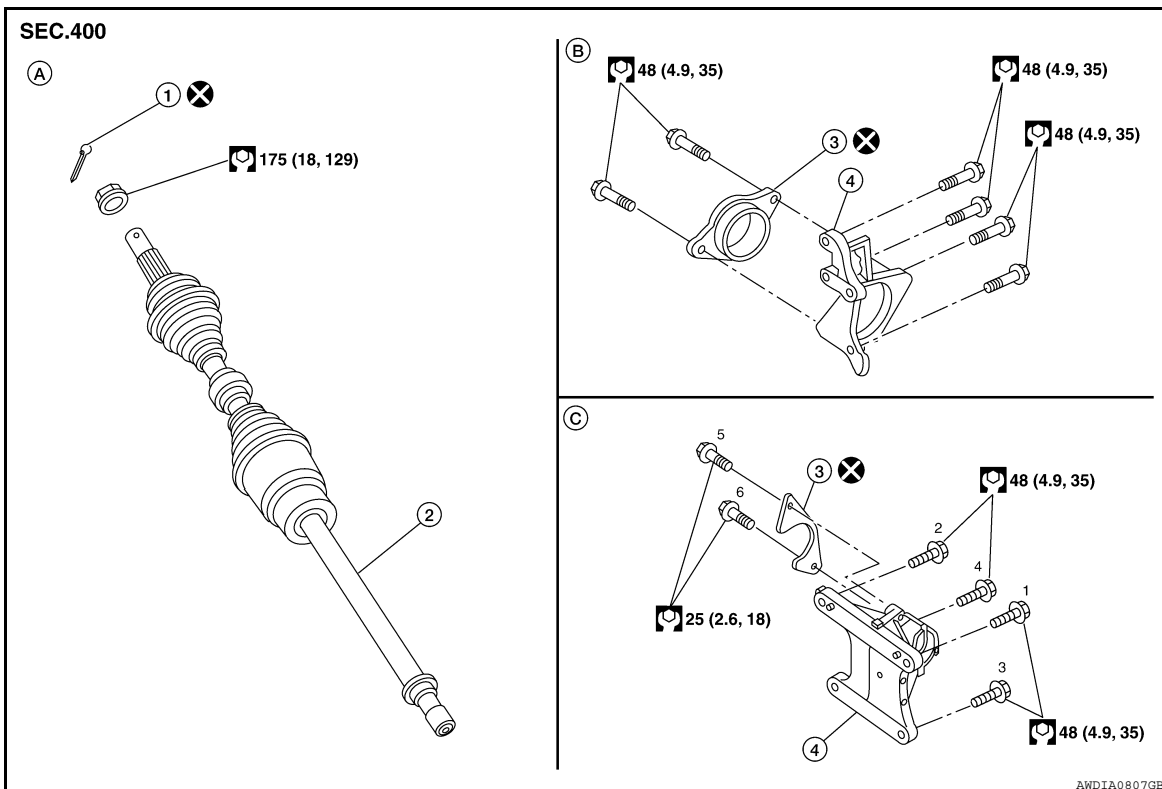

FRONT DRIVE SHAFT

< ON-VEHICLE REPAIR >

- | | | |
|----------------------------|-------------------------|----------------------|
| 1. Cotter pin | 2. Drive shaft | 3. Retaining bracket |
| 4. Support bearing bracket | A. Front RH drive shaft | B. VQ35DE engine |
| C. QR25DE engine | | |

Removal and Installation (Right Side)

INFOID:000000005786170

REMOVAL

1. Remove wheel and tire using power tool.
2. Remove wheel sensor from steering knuckle. Refer to [BRC-57, "Removal and installation"](#) (ABS), [BRC-163, "Removal and Installation"](#) (VDC/TCS/ABS).
3. Remove cotter pin. Then remove lock nut from drive shaft using power tool.
4. Remove brake hose lock plate. Then remove brake hose from strut.
5. Remove brake caliper using power tool, leaving hydraulic brake line attached. Hang caliper aside using wire. Refer to [BR-31, "BRAKE CALIPER ASSEMBLY: Removal and Installation"](#).
6. Remove front strut to steering knuckle bolts and nuts, then separate steering knuckle front strut. Refer to [FSU-8, "Removal and Installation"](#).
7. Remove drive shaft from wheel hub and bearing assembly, using a puller or suitable tool.

CAUTION:

- When removing drive shaft, do not apply an excessive angle to drive shaft joint. Also be careful not to excessively extend slide joint.

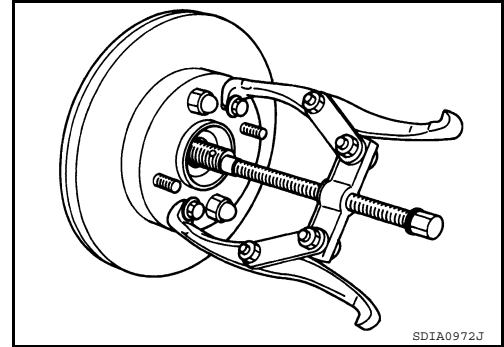

8. Remove retaining bracket bolts using power tool, and pry drive shaft from transaxle.

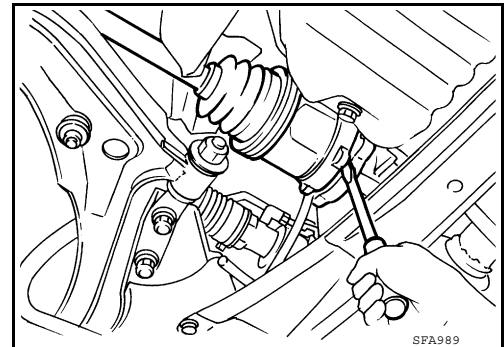

INSPECTION AFTER REMOVAL

- Move joint up/down, left/right, and in axial direction. Check for any rough movement or significant looseness.
- Check boot for cracks or other damage, and for grease leakage.
- If damaged, disassemble drive shaft to verify damage, and repair or replace as necessary.

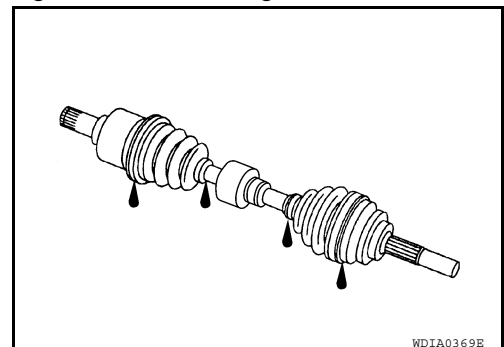

INSTALLATION

Installation is in the reverse order of removal.

A

B

C

FAX

E

F

G

H

I

J

K

L

M

N

O

P

FRONT DRIVE SHAFT

< ON-VEHICLE REPAIR >

- Tighten retaining bracket bolts and support bearing bracket bolts to specifications. Refer to [FAX-10. "Exploded View"](#).
- For QR25DE models, install the retaining bracket with the notch facing up and follow the bolt tightening order.

CAUTION:

Do not reuse non-reusable parts.

- In order to prevent damage to differential side oil seal, place Tool (A) onto oil seal before inserting drive shaft as shown. Slide drive shaft into slide joint and tap with a hammer to install securely.

Tool number : KV38106800 (J-34297)

- Install new circlip on drive shaft in the circular clip groove on transaxle side. Refer to [FAX-18. "Disassembly and Assembly \(Right Side\)"](#).

CAUTION:

Make sure the new circlip on the drive shaft is securely fastened.

- After its insertion, try to pull the flange out of the slide joint by hand. If it pulls out, the circlip is not properly meshed with the transaxle side gear.

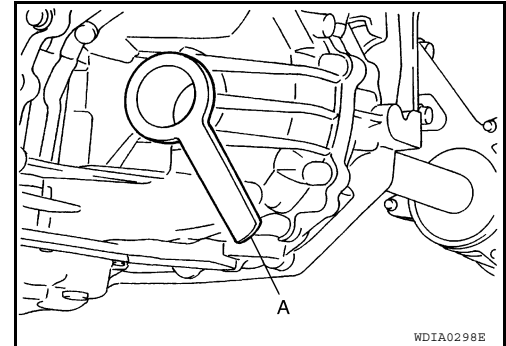

FRONT DRIVE SHAFT

< DISASSEMBLY AND ASSEMBLY >

DISASSEMBLY AND ASSEMBLY

FRONT DRIVE SHAFT

Disassembly and Assembly (Left Side)

INFOID:000000005430065

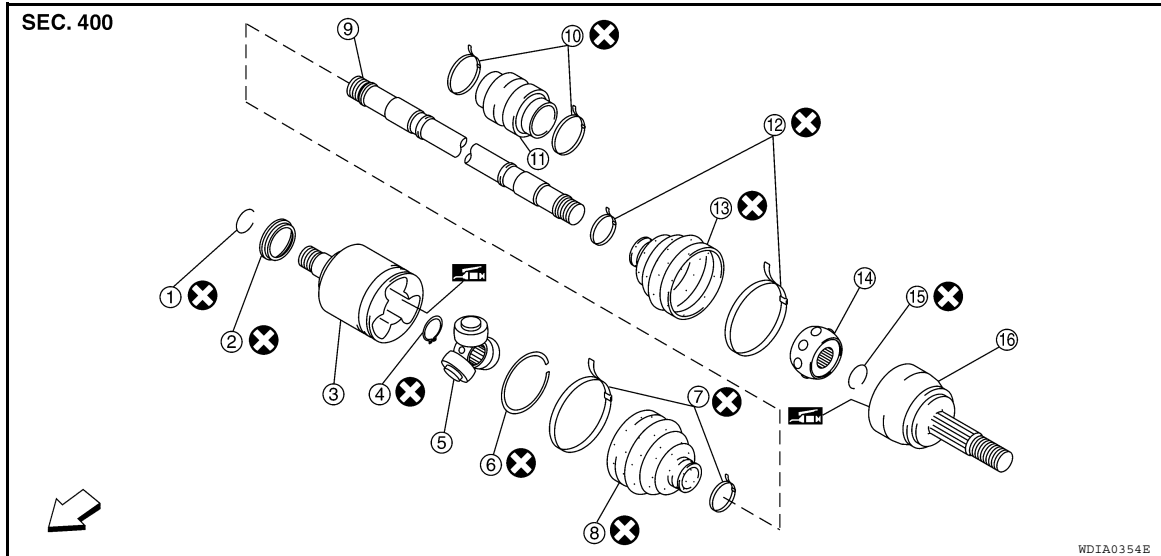

- | | | |
|------------------------|--|------------------------|
| 1. Circlip | 2. Dust shield | 3. Slide joint housing |
| 4. Snap ring | 5. Spider assembly | 6. Stopper ring |
| 7. Boot band | 8. Boot | 9. Shaft |
| 10. Damper band | 11. Damper | 12. Boot band |
| 13. Boot | 14. Ball cage / Steel ball / Inner race assembly | 15. Circlip |
| 16. Joint sub-assembly | ← Front | |

DISASSEMBLY

Transaxle Side

1. Mount front drive shaft in a vise.

CAUTION:

When mounting shaft in a vise, always use copper or aluminum plates between vise and shaft.

2. Remove boot bands and slide the boot back.
3. Remove circlip and dust shield from slide joint housing.
4. Put matching marks on slide joint housing and shaft before separating joint assembly.
5. Remove stopper ring with a suitable tool, then pull out slide joint housing.

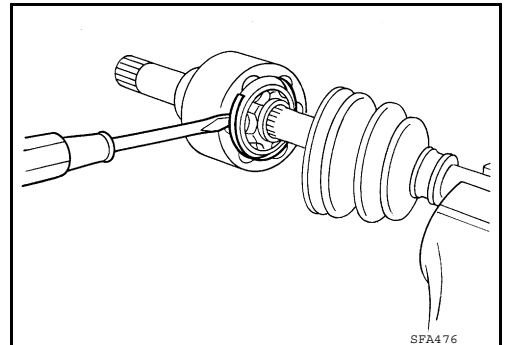

FRONT DRIVE SHAFT

< DISASSEMBLY AND ASSEMBLY >

- Put matching marks on spider assembly and shaft.

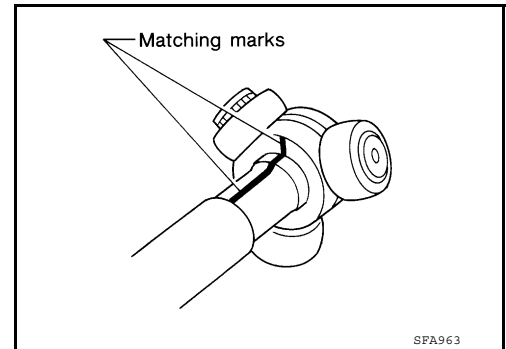

- Remove snap ring using a suitable tool, then remove spider assembly from shaft.
- Remove boot from shaft.
- Clean the old grease off of the slide joint assembly.

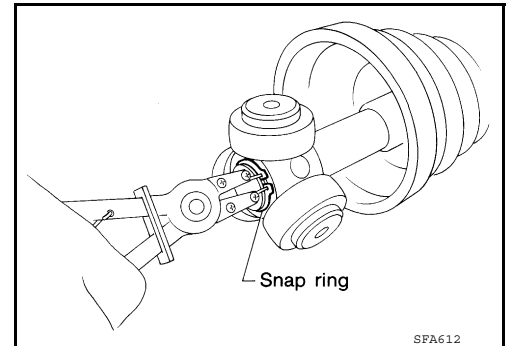

Wheel Side

- Mount the front drive shaft in a vise.

CAUTION:

When mounting shaft in a vise, always use copper or aluminum plates between vise and shaft.

- Remove boot bands and slide the boot back.
- Screw a sliding hammer or suitable tool 30 mm (1.18 in) or more into threaded part of joint sub-assembly. Pull joint sub-assembly out of shaft.

CAUTION:

- Align sliding hammer or suitable tool and drive shaft then remove joint sub-assembly by pulling directly.
- If joint sub-assembly cannot be removed after five or more unsuccessful attempts, replace the entire drive shaft assembly.

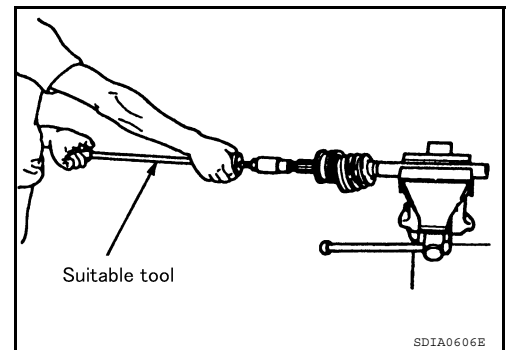

- Remove boot from shaft.
- Remove circlip from shaft.
- While rotating ball cage, clean the old grease off of the joint sub-assembly.

Damper

- Remove damper bands, then remove damper from shaft.

INSPECTION AFTER DISASSEMBLY

Shaft

- Replace shaft if there is bending, cracking, or other damage.

Joint Sub-Assembly

- Make sure there is no rough rotation or unusual axial looseness.
- Make sure there is no foreign material inside joint sub-assembly.
- Check joint sub-assembly for compression scars, cracks or fractures.

CAUTION:

If there are any irregular conditions of joint sub-assembly components, replace the entire joint sub-assembly.

FRONT DRIVE SHAFT

< DISASSEMBLY AND ASSEMBLY >

Slide Joint Housing

- Make sure there are no compression scars, cracks or fractures or unusual wear of ball rolling surface.
- Make sure there is no damage to shaft screws.
- Make sure there is no deformation of boot installation parts.

Ball Cage

- Make sure there are no compression scars, cracks, fractures of sliding surface.

Steel Ball

- Make sure there are no compression scars, cracks, fractures or unusual wear.

Inner Race

- Check ball sliding surface for compression scars, cracks or fractures.
- Make sure there is no damage to serrated part.

CAUTION:

If there are any irregular conditions in the component, replace with a new set of joint sub-assembly, ball cage, steel ball and inner race.

Damper

- Check damper for cracks or wear. Install damper with new damper bands.

ASSEMBLY

Transaxle Side

1. Install new boot and new small boot band on shaft.

CAUTION:

- **Cover drive shaft serration with tape to prevent damage to boot during installation.**

2. Remove protective tape wound around serrated part of shaft.

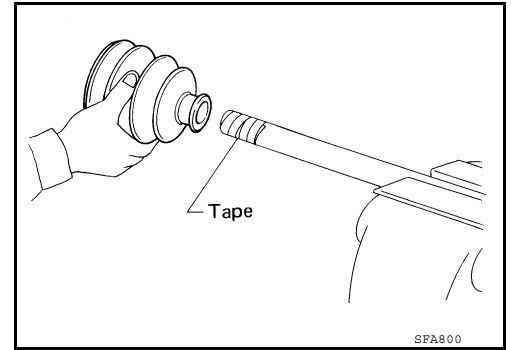

3. Install spider assembly securely, making sure the matching marks which were made during disassembly are properly aligned.
4. Install new snap ring using a suitable tool.
5. Pack drive shaft with specified amount of new grease (Genuine NISSAN Grease or equivalent).

Grease amount : 134 – 144 g (4.73 – 5.08 oz)

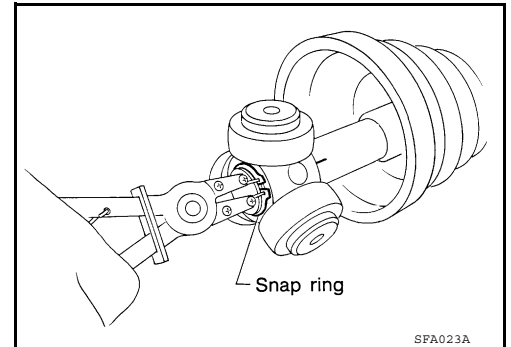

6. Install new stopper ring to housing of slide joint assembly.
7. After installation, pull shaft to check engagement between slide joint assembly and stopper ring.

A
B
C
FAX
E
F
G
H
I
J
K
L
M
N
O
P

FRONT DRIVE SHAFT

< DISASSEMBLY AND ASSEMBLY >

8. Install boot securely into grooves (indicated by * marks) as shown.

CAUTION:

If there is grease on boot mounting surfaces (indicated by * marks) of shaft and housing, boot may come off. Clean all grease from surfaces.

9. Make sure boot installation length (L) is the length specified below. Insert a flat-bladed screwdriver or similar tool into the large end of boot. Bleed air from boot to prevent boot deformation.

Boot installation length (L) : 167.9 mm (6.61 in)

CAUTION:

- Boot may break if boot installation length is less than standard value.
- Be careful that screwdriver tip does not contact inside surface of boot.

10. Secure large and small ends of boot with new boot bands as shown.

CAUTION:

Discard old boot bands and replace with new ones.

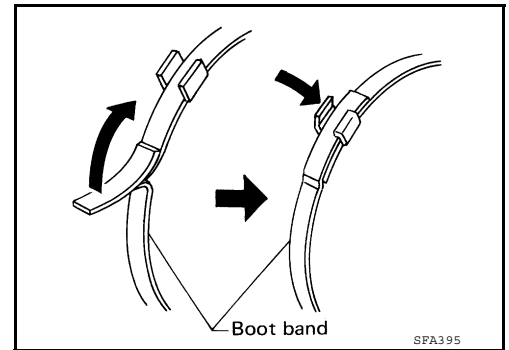
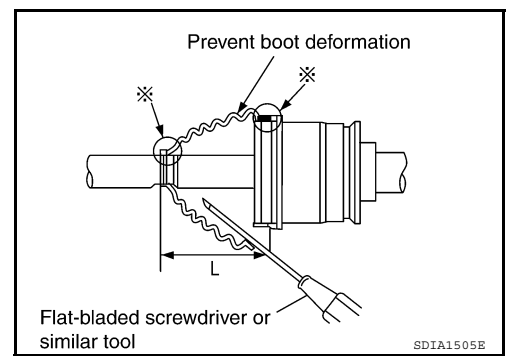

11. Install new dust shield to slide joint housing.

12. After installing housing and shaft, make sure boot position is correct. If boot position is not correct, remove old boot bands then reposition the boot and secure with new boot bands.

Wheel Side

1. Insert the amount of grease (Genuine NISSAN Grease or equivalent) into joint sub-assembly serration hole until grease begins to ooze from ball groove and serration hole. After inserting grease, use a shop cloth to wipe off old grease that has oozed out.

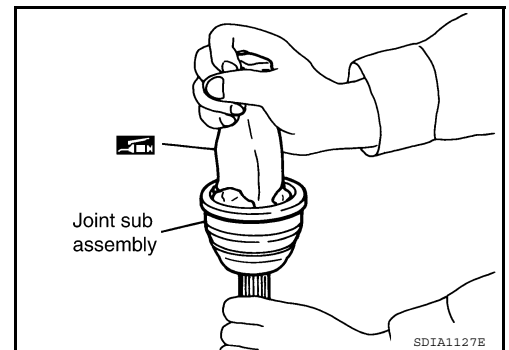

2. Cover serrated part of shaft with tape. Install new boot band and boot to shaft. Be careful not to damage boot.

CAUTION:

Discard old boot band and boot; replace with new one.

3. Remove protective tape wound around serrated part of shaft.

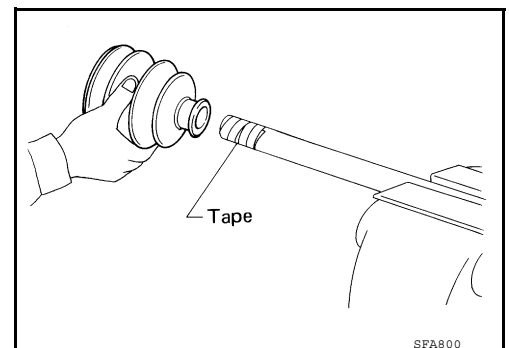

FRONT DRIVE SHAFT

< DISASSEMBLY AND ASSEMBLY >

4. Attach new circlip to shaft. The circlip must fit securely into shaft groove. Attach nut to joint sub-assembly. Use a suitable tool to press-fit.

CAUTION:

Discard old circlip and replace with new one.

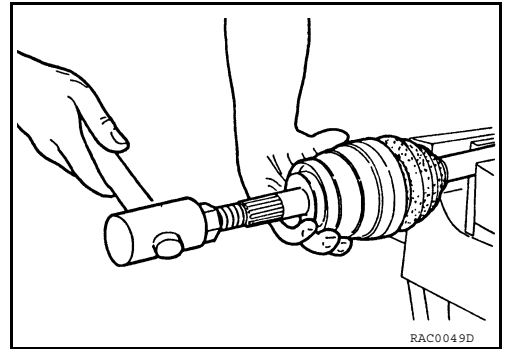

5. Insert the amount of new grease (Genuine NISSAN Grease or equivalent) listed below into housing from large end of boot.

Grease amount : 170 – 190 g (6.00 – 6.70 oz)

6. Install boot securely into grooves (indicated by * marks) as shown.

CAUTION:

If there is grease on boot mounting surfaces (indicated by * marks) of shaft and housing, boot may come off. Remove all grease from surfaces.

7. Make sure boot installation length (L) is the specified length indicated below. Insert a flat-bladed screwdriver or similar tool into the large end of boot. Bleed air from boot to prevent boot deformation.

Boot installation length (L) : 163 mm (6.42 in)

CAUTION:

- Boot may break if boot installation length is less than standard value.
- Be careful that screwdriver tip does not contact inside surface of boot.

8. Install new large and small boot bands securely using Tool.

Tool number : KV40107300 (—)

NOTE:

Do not reuse boot bands.

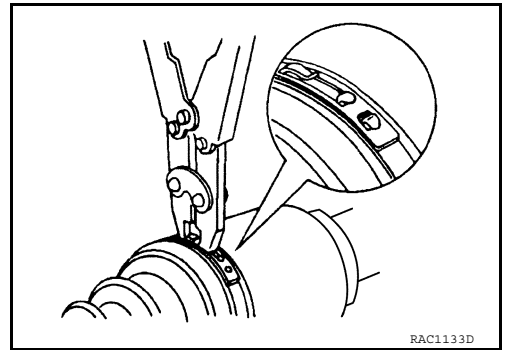
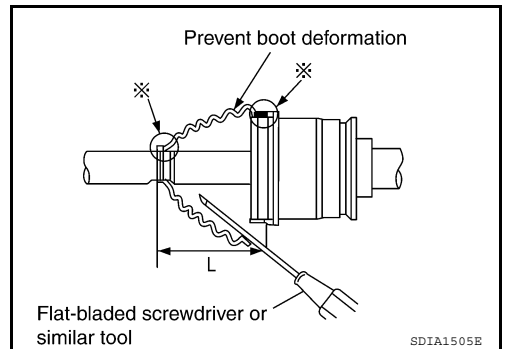

CAUTION:

- Secure boot band so that dimension (M) meets specification as shown.

Dimension (M) : 1.0 – 4.0 mm (0.039 – 0.157 in)

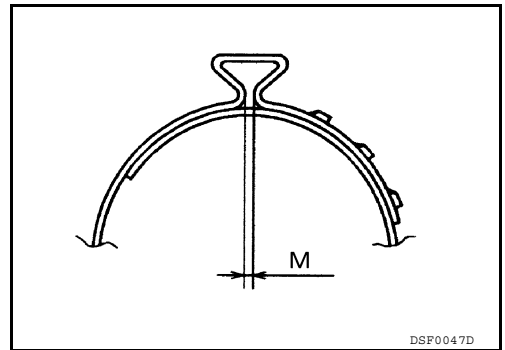

9. After installing housing and shaft, rotate boot to check whether or not the actual position is correct. If boot position is not correct, remove old boot bands then reposition the boot and secure with new boot bands.

A
B
C
FAX
E
F
G
H
I
J
K
L
M
N
O
P

FRONT DRIVE SHAFT

< DISASSEMBLY AND ASSEMBLY >

Damper

1. Use new damper bands for installation.
2. Install damper from stationary-joint side while holding it securely.

- (A) : 205 – 215 mm (8.07 – 8.46 in)
 (B) : 70 mm (2.76 in)

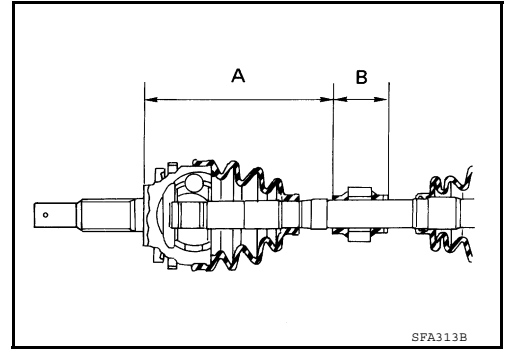

Disassembly and Assembly (Right Side)

INFOID:000000005430066

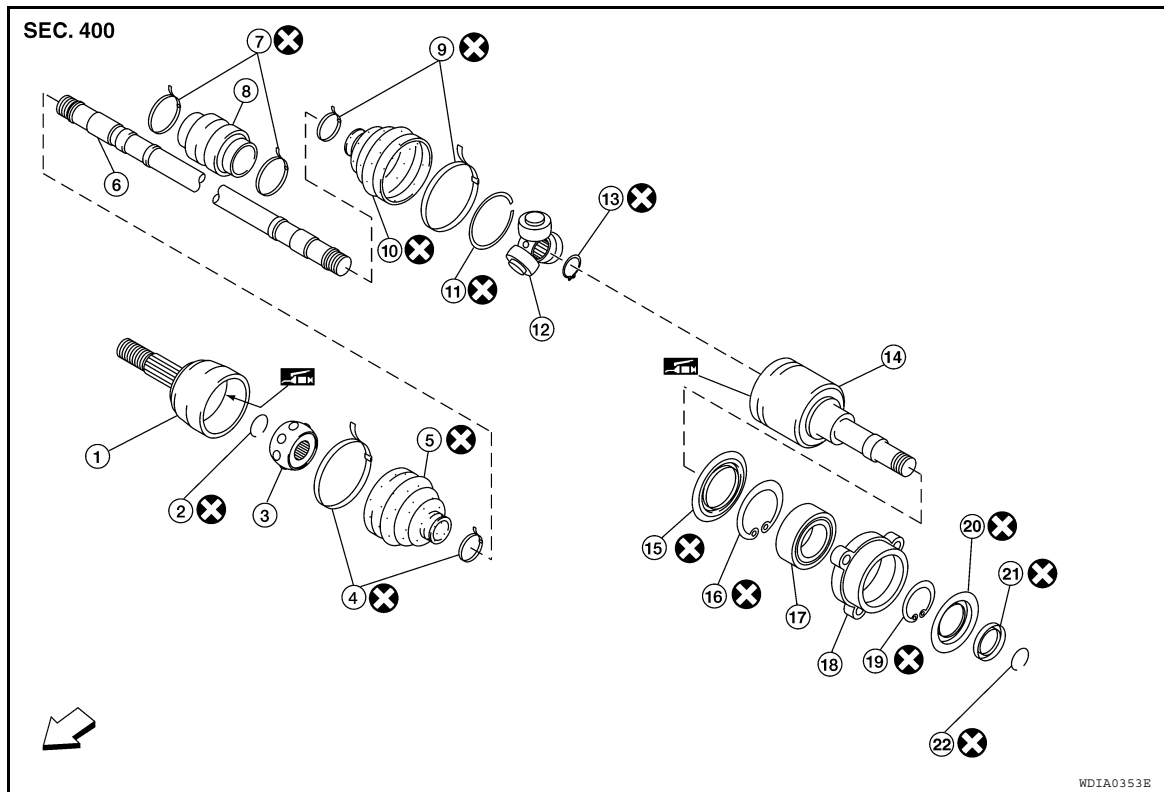

- | | | |
|-----------------------|-------------------------|---|
| 1. Joint sub-assembly | 2. Circlip | 3. Ball cage / Steel ball / Inner race assembly |
| 4. Boot bands | 5. Boot | 6. Shaft |
| 7. Damper bands | 8. Damper | 9. Boot band |
| 10. Boot | 11. Stopper ring | 12. Spider assembly |
| 13. Snap ring | 14. Slide joint housing | 15. Dust cover |
| 16. Snap ring | 17. Bearing | 18. Retaining bracket (QR25DE engine) |
| 19. Snap ring | 20. Dust shield | 21. Dust shield |
| 22. Circlip | ⇐ Front | |

DISASSEMBLY

Transaxle Side

1. Press shaft in a vise.
CAUTION:
When retaining shaft in a vise, always use copper or aluminum plates between vise and shaft.
2. Remove circlip and dust shield from slide joint housing.

FRONT DRIVE SHAFT

< DISASSEMBLY AND ASSEMBLY >

3. Remove boot bands and slide the boots back.
4. Put matching marks on slide joint housing and shaft before separating slide joint housing.
5. Remove stopper ring using a suitable tool, then pull out slide joint housing.

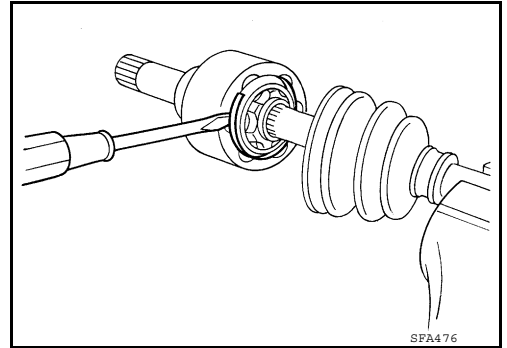

6. Put matching marks on spider assembly and shaft.

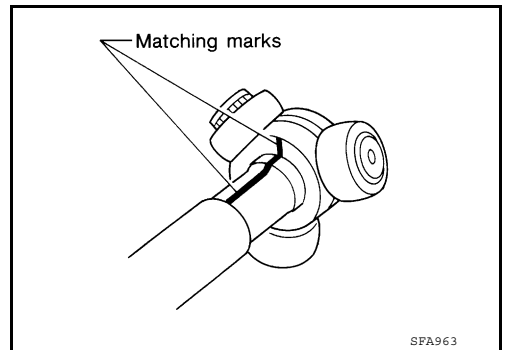

7. Remove snap ring using a suitable tool, then remove spider assembly from shaft.
8. Remove boot from shaft.
9. Clean old grease off of the slide joint housing.

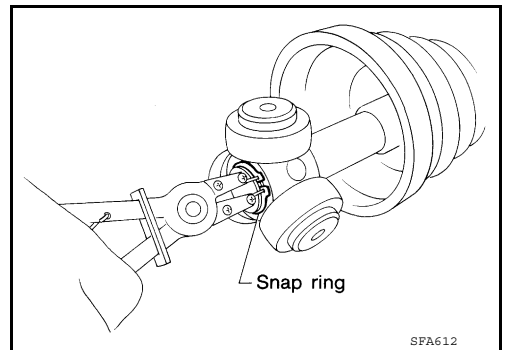

Wheel Side

1. Mount the front drive shaft in a vise.

CAUTION:

When mounting shaft in a vise, always use copper or aluminum plates between vise and shaft.

2. Remove boot bands and slide the boot back.
3. Screw a sliding hammer or suitable tool 30 mm (1.18 in) or more into threaded part of joint sub-assembly. Pull joint sub-assembly out of shaft.

CAUTION:

- Align sliding hammer or suitable tool and drive shaft then remove joint sub-assembly by pulling directly.
- If joint sub-assembly cannot be removed after five or more unsuccessful attempts, replace the entire drive shaft assembly.

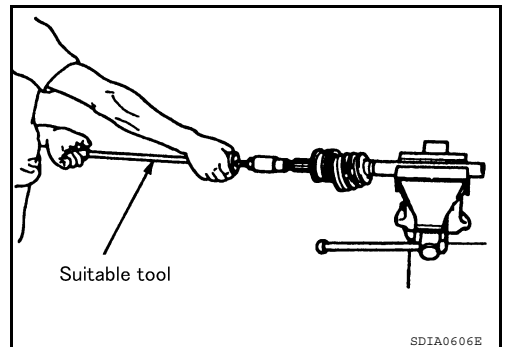

4. Remove boot from shaft.
5. Remove circlip from shaft.
6. While rotating ball cage, clean the old grease off of the joint sub-assembly.

FRONT DRIVE SHAFT

< DISASSEMBLY AND ASSEMBLY >

Support Bearing

1. Remove dust shield from slide joint assembly using a suitable tool.

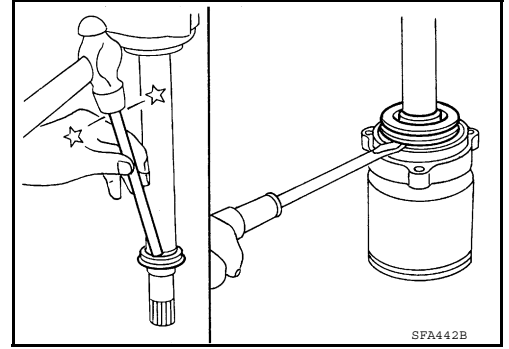

2. Remove snap ring using a suitable tool.

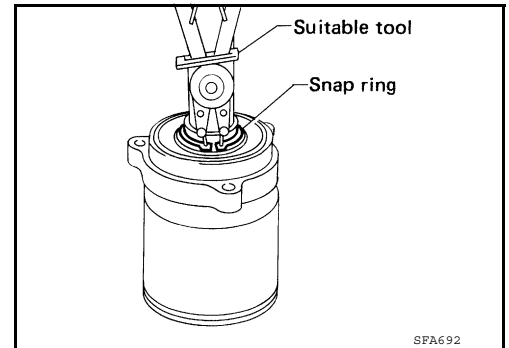

3. Press support bearing assembly off slide joint assembly using a suitable tool.

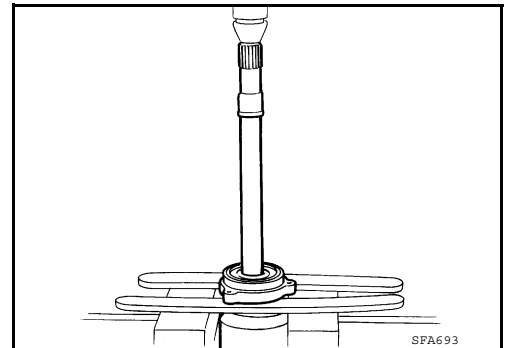

4. With QR25DE engine, separate support bearing from retaining bracket using a suitable tool.

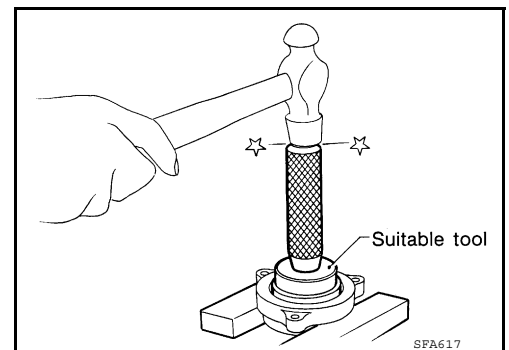

Damper

- Remove damper bands, then remove damper from shaft.

INSPECTION AFTER DISASSEMBLY

Shaft

- Replace shaft if there is any bending, cracking, or other damage.

Joint Sub-assembly

- Make sure there is no rough rotation or unusual axial looseness.
- Make sure there is no foreign material inside joint sub-assembly.
- Check joint sub-assembly for compression scars, cracks or fractures.

FRONT DRIVE SHAFT

< DISASSEMBLY AND ASSEMBLY >

CAUTION:

If there are any irregular conditions of joint sub-assembly components, replace the entire joint sub-assembly.

Sliding Joint Housing and Spider Assembly

- If roller surface of spider assembly has scratches or wear, replace housing and spider assembly.

NOTE:

Housing and spider assembly are components which are used as a set.

Support Bearing

- Make sure wheel bearing rolls freely and is free from noise, cracks, pitting or wear.

Damper

- Check damper for cracks or wear. Install damper with new damper bands.

ASSEMBLY

Transaxle Side

1. Cover serrated part of shaft with tape. Install new boot and boot band onto shaft. Be careful not to damage boot.

CAUTION:

- **Discard old boot and boot band; replace with new ones.**

2. Remove protective tape wound around serrated part of shaft.

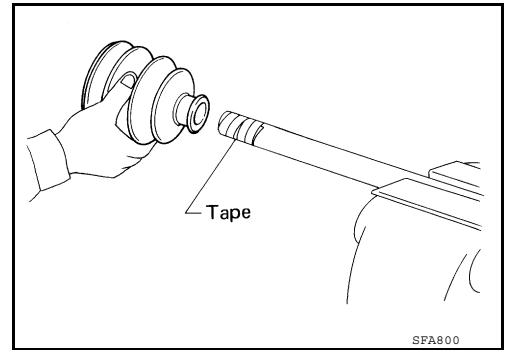

3. Install spider assembly securely, making sure the matching marks which were made during disassembly are properly aligned.
4. Install new snap ring using a suitable tool.
5. Pack drive shaft with specified amount of grease (Genuine NIS-SAN Grease or equivalent).

Grease amount : 134 - 144 g (4.73 - 5.08 oz)

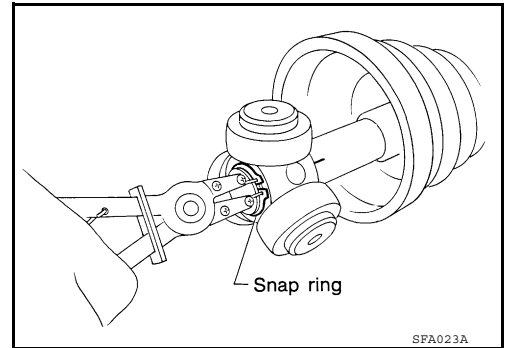

6. Install new stopper ring to slide joint assembly.
7. After installation, pull shaft to check engagement between slide joint assembly and stopper ring.
8. Install boot securely into grooves (indicated by * marks) as shown.

CAUTION:

If there is grease on boot mounting surfaces (indicated by * marks) of shaft and housing, boot may come off. Remove all grease from surfaces.

9. Make sure boot installation length (L) is the length indicated below. Insert a flat-bladed screwdriver or similar tool into the large end of boot. Bleed air from boot to prevent boot deformation.

Boot installation length (L) : 189.30 mm (7.45 in)

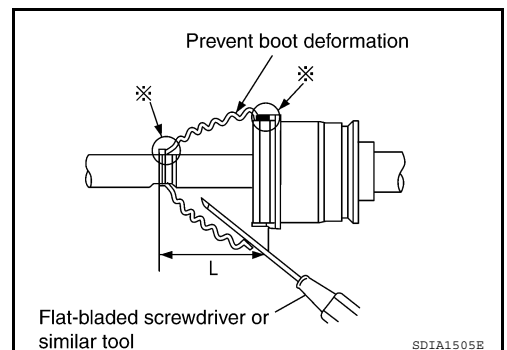

CAUTION:

- **Boot may break if boot installation length is less than standard value.**
- **Be careful that screwdriver tip does not contact inside surface of boot.**

FRONT DRIVE SHAFT

< DISASSEMBLY AND ASSEMBLY >

10. Secure big and small ends of boot with new boot bands as shown.

CAUTION:

Discard old boot bands; replace with new ones.

11. Install new dust shield to slide joint housing.
12. After installing housing and shaft, rotate boot to check whether or not the actual position is correct. If boot position is not correct, remove old boot bands then reposition the boot and secure with new boot bands.

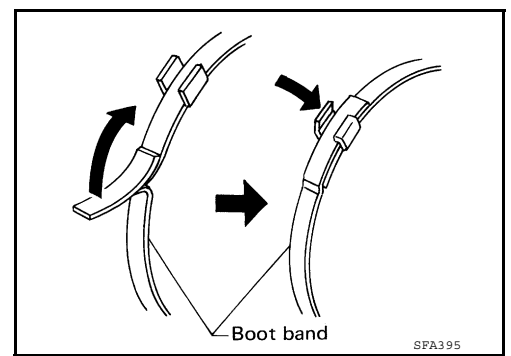

Wheel Side

1. Insert the amount of grease (Genuine NISSAN Grease or equivalent) into joint sub-assembly serration hole until grease begins to ooze from ball groove and serration hole. After inserting grease, use a shop cloth to wipe off old grease that has oozed out.

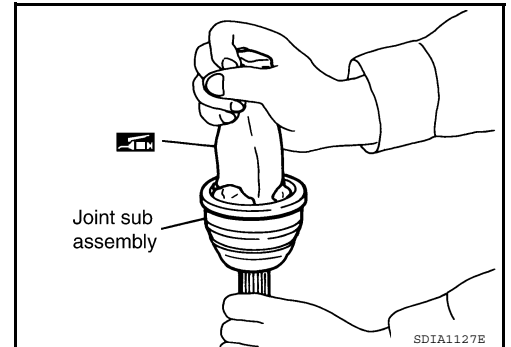

2. Cover serrated part of shaft with tape. Install new boot and boot band onto shaft. Be careful not to damage boot.

CAUTION:

Discard old boot and boot band; replace with new ones.

3. Remove protective tape wound around serrated part of shaft.

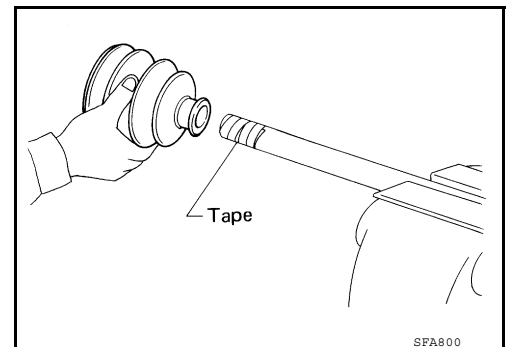

4. Attach new circlip to shaft. The circlip must fit securely into shaft groove. Attach nut to joint sub-assembly. Use a suitable tool to press-fit.

CAUTION:

Discard old circlip; replace with new ones.

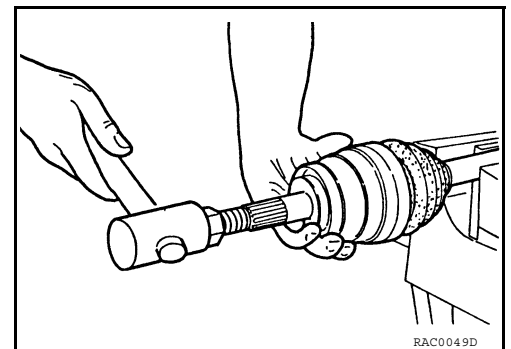

5. Insert the amount of new grease (Genuine NISSAN Grease or equivalent) listed below into housing from large end of boot.

Grease amount : 170 – 190 g (6.00 – 6.70 oz)

FRONT DRIVE SHAFT

< DISASSEMBLY AND ASSEMBLY >

6. Install boot securely into grooves (indicated by * marks) as shown.

CAUTION:

If there is grease on boot mounting surfaces (indicated by * marks) of shaft and housing, boot may come off. Remove all grease from surfaces.

7. Make sure boot installation length (L) is the specified length. Insert a flat-bladed screwdriver or similar tool into the large end of boot. Bleed air from boot to prevent boot deformation.

Boot installation length (L) : 163 mm (6.42 in)

CAUTION:

- Boot may break if boot installation length is less than standard value.
- Be careful that screwdriver tip does not contact inside surface of boot.

8. Install new large and small boot bands securely using Tool.

Tool number : KV40107300 (—)

NOTE:

Do not reuse boot bands.

CAUTION:

- Secure boot band so that dimension (M) meets specification as shown.

Dimension (M) : 1.0 – 4.0 mm (0.039 – 0.157 in)

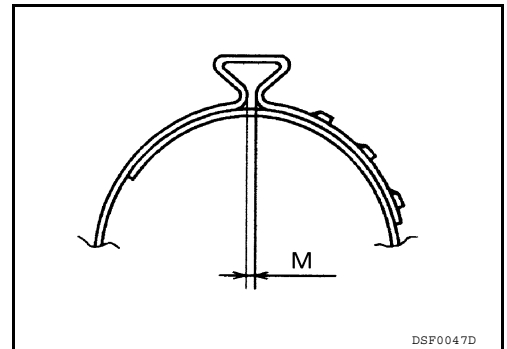
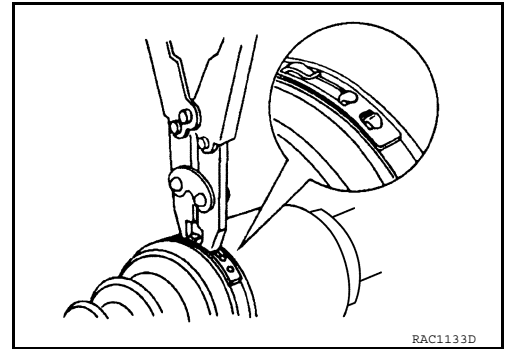
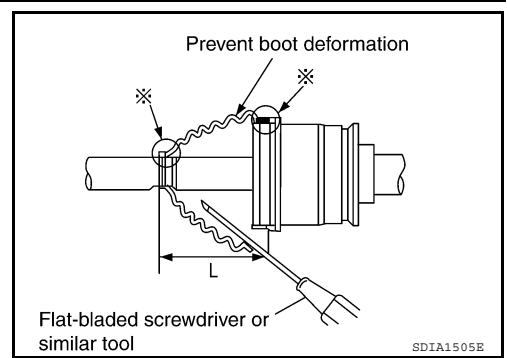

9. After installing housing and shaft, rotate boot to check whether or not the actual position is correct. If boot position is not correct, remove old boot bands then reposition the boot and secure with new boot bands.

Support Bearing

1. With QR25DE engine, press support bearing into retaining bracket using a suitable tool.
2. Install support bearing onto slide joint assembly.
3. Install snap ring.
4. Install dust shield.

Damper

A
B
C
FAX
E
F
G
H
I
J
K
L
M
N
O
P

FRONT DRIVE SHAFT

< DISASSEMBLY AND ASSEMBLY >

1. Use new damper bands for installation.
2. Install damper from stationary-joint side while holding it securely.

(A) : 205 – 215 mm (8.07 – 8.46 in)

(B) : 70 mm (2.76 in)

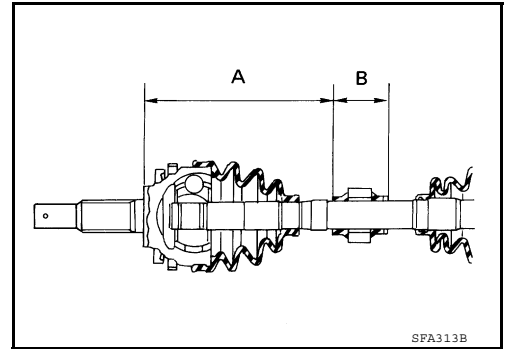

SERVICE DATA AND SPECIFICATIONS (SDS)

< SERVICE DATA AND SPECIFICATIONS (SDS)

SERVICE DATA AND SPECIFICATIONS (SDS)

SERVICE DATA AND SPECIFICATIONS (SDS)

Wheel Bearing

INFOID:000000005430067

Axial end play limit	0.05 mm (0.002 in) or less
----------------------	----------------------------

Drive Shaft

INFOID:000000005430068

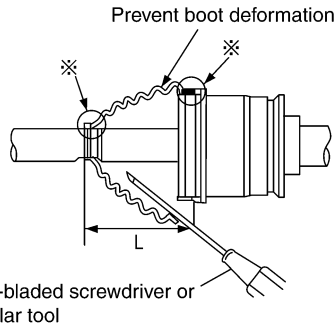

Joint type	Wheel side		Transaxle side	
	LH	RH	LH	RH
Grease quantity	170 - 190 g (6.00 - 6.70 oz)		134 - 144 g (4.73 - 5.08 oz)	
Boots installed length	163 mm (6.42 in)		167.9 mm (6.61 in)	189.30 (7.45 in)

Dynamic Damper

INFOID:000000005430069

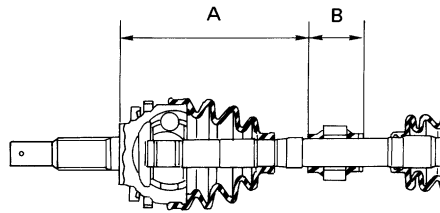

(A)	205 - 215 mm (8.07 - 8.46 in)
(B)	70 mm (2.76 in)

SERVICE DATA AND SPECIFICATIONS (SDS)

< SERVICE DATA AND SPECIFICATIONS (SDS)

Boot Bands

INFOID:000000005430070

Unit: mm (in)

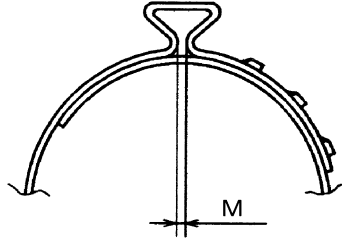

DSP0047D

Dimension (M)	1.0 - 4.0 (0.039 - 0.157)
---------------	---------------------------