

SECTION **RAX**
REAR AXLE

A
B
C

RAX

CONTENTS

E
F
G
H
I
J
K
L
M
N
O
P

PRECAUTION	2	ON-VEHICLE MAINTENANCE	5
PRECAUTIONS	2	WHEEL HUB	5
Precaution for Supplemental Restraint System (SRS) "AIR BAG" and "SEAT BELT PRE-TENSIONER"	2	On-vehicle Service	5
General Precautions	2	ON-VEHICLE REPAIR	6
SYMPTOM DIAGNOSIS	3	WHEEL HUB	6
NOISE, VIBRATION, AND HARSHNESS(NVH) TROUBLESHOOTING	3	Removal and Installation	6
NVH Troubleshooting Chart	3	SERVICE DATA AND SPECIFICATIONS (SDS)	8
PREPARATION	4	SERVICE DATA AND SPECIFICATIONS (SDS)	8
PREPARATION	4	Wheel Hub Bearing	8
Commercial Service Tool	4		

PRECAUTIONS

< PRECAUTION >

PRECAUTION

PRECAUTIONS

Precaution for Supplemental Restraint System (SRS) "AIR BAG" and "SEAT BELT PRE-TENSIONER"

INFOID:000000005783544

The Supplemental Restraint System such as "AIR BAG" and "SEAT BELT PRE-TENSIONER", used along with a front seat belt, helps to reduce the risk or severity of injury to the driver and front passenger for certain types of collision. This system includes seat belt switch inputs and dual stage front air bag modules. The SRS system uses the seat belt switches to determine the front air bag deployment, and may only deploy one front air bag, depending on the severity of a collision and whether the front occupants are belted or unbelted. Information necessary to service the system safely is included in the SR and SB section of this Service Manual.

WARNING:

- To avoid rendering the SRS inoperative, which could increase the risk of personal injury or death in the event of a collision which would result in air bag inflation, all maintenance must be performed by an authorized NISSAN/INFINITI dealer.
- Improper maintenance, including incorrect removal and installation of the SRS, can lead to personal injury caused by unintentional activation of the system. For removal of Spiral Cable and Air Bag Module, see the SR section.
- Do not use electrical test equipment on any circuit related to the SRS unless instructed to in this Service Manual. SRS wiring harnesses can be identified by yellow and/or orange harnesses or harness connectors.

PRECAUTIONS WHEN USING POWER TOOLS (AIR OR ELECTRIC) AND HAMMERS

WARNING:

- When working near the Airbag Diagnosis Sensor Unit or other Airbag System sensors with the Ignition ON or engine running, DO NOT use air or electric power tools or strike near the sensor(s) with a hammer. Heavy vibration could activate the sensor(s) and deploy the air bag(s), possibly causing serious injury.
- When using air or electric power tools or hammers, always switch the Ignition OFF, disconnect the battery, and wait at least 3 minutes before performing any service.

General Precautions

INFOID:000000005433581

- When installing each rubber part, final tightening must be carried out under unladen condition* with tires on ground.
*: Fuel, radiator coolant and engine oil full. Spare tire, jack, hand tools and mats in designated positions.
- After installing removed suspension parts, check wheel alignment.
- Do not jack up at the trailing arm and lateral link.

NOISE, VIBRATION, AND HARSHNESS(NVH) TROUBLESHOOTING

< SYMPTOM DIAGNOSIS >

SYMPTOM DIAGNOSIS

NOISE, VIBRATION, AND HARSHNESS(NVH) TROUBLESHOOTING

NVH Troubleshooting Chart

INFOID:000000005433578

Use the chart below to help you find the cause of the symptom. If necessary, repair or replace these parts.

Reference page		RAX-6	RAX-6	RAX-6	WT-60. "NVH Troubleshooting Chart"	WT-60. "NVH Troubleshooting Chart"	
Possible cause and SUSPECTED PARTS		Improper installation, looseness	Parts interference	Wheel bearing damage	TIRES	ROAD WHEEL	
Symptom	REAR AXLE	Noise	x	x		x	x
		Shake	x	x		x	x
		Vibration	x	x		x	
		Shimmy	x	x		x	x
		Shudder	x			x	x
		Poor quality ride or handling	x	x	x	x	x

x: Applicable

A
B
C
RAX
E
F
G
H
I
J
K
L
M
N
O
P

PREPARATION

< PREPARATION >

PREPARATION

PREPARATION

Commercial Service Tool

INFOID:000000005433582

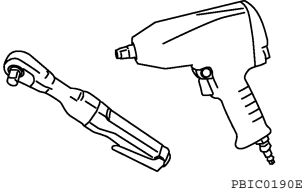
Tool name	Description
<p data-bbox="140 415 252 441">Power tool</p>  <p data-bbox="837 634 911 646">PBIC0190E</p>	<p data-bbox="999 415 1254 441">Loosening bolts and nuts</p>

WHEEL HUB

< ON-VEHICLE MAINTENANCE >

ON-VEHICLE MAINTENANCE

WHEEL HUB

On-vehicle Service

INFOID:000000005796896

Check axle and suspension parts for excessive play, wear or damage.

- Shake each rear wheel to check for excessive play.

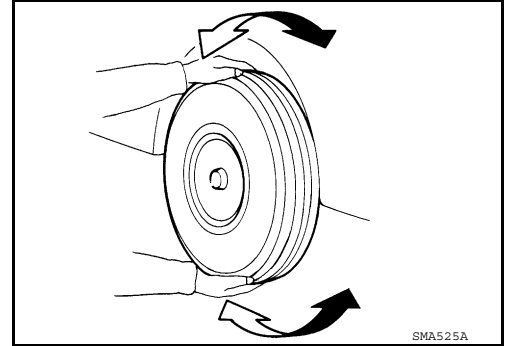

Wheel Hub Bearing

- Check wheel hub bearing axial end play.

Axial end play : 0.1 mm (0.004 in) or less

- Check that wheel hub bearings operate smoothly.
- Replace wheel hub assembly if there is axial end play or wheel bearing does not turn smoothly. Refer to [RAX-6. "Removal and Installation"](#).

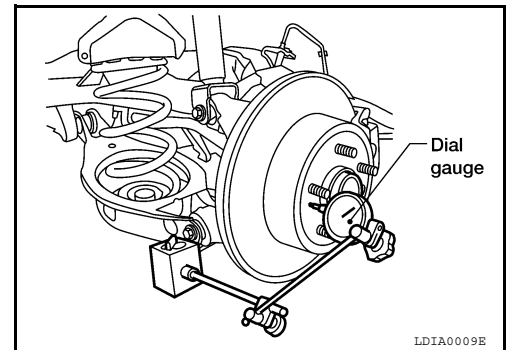

A
B
C
RAX
E
F
G
H
I
J
K
L
M
N
O
P

WHEEL HUB

< ON-VEHICLE REPAIR >

ON-VEHICLE REPAIR

WHEEL HUB

Removal and Installation

INFOID:000000005796894

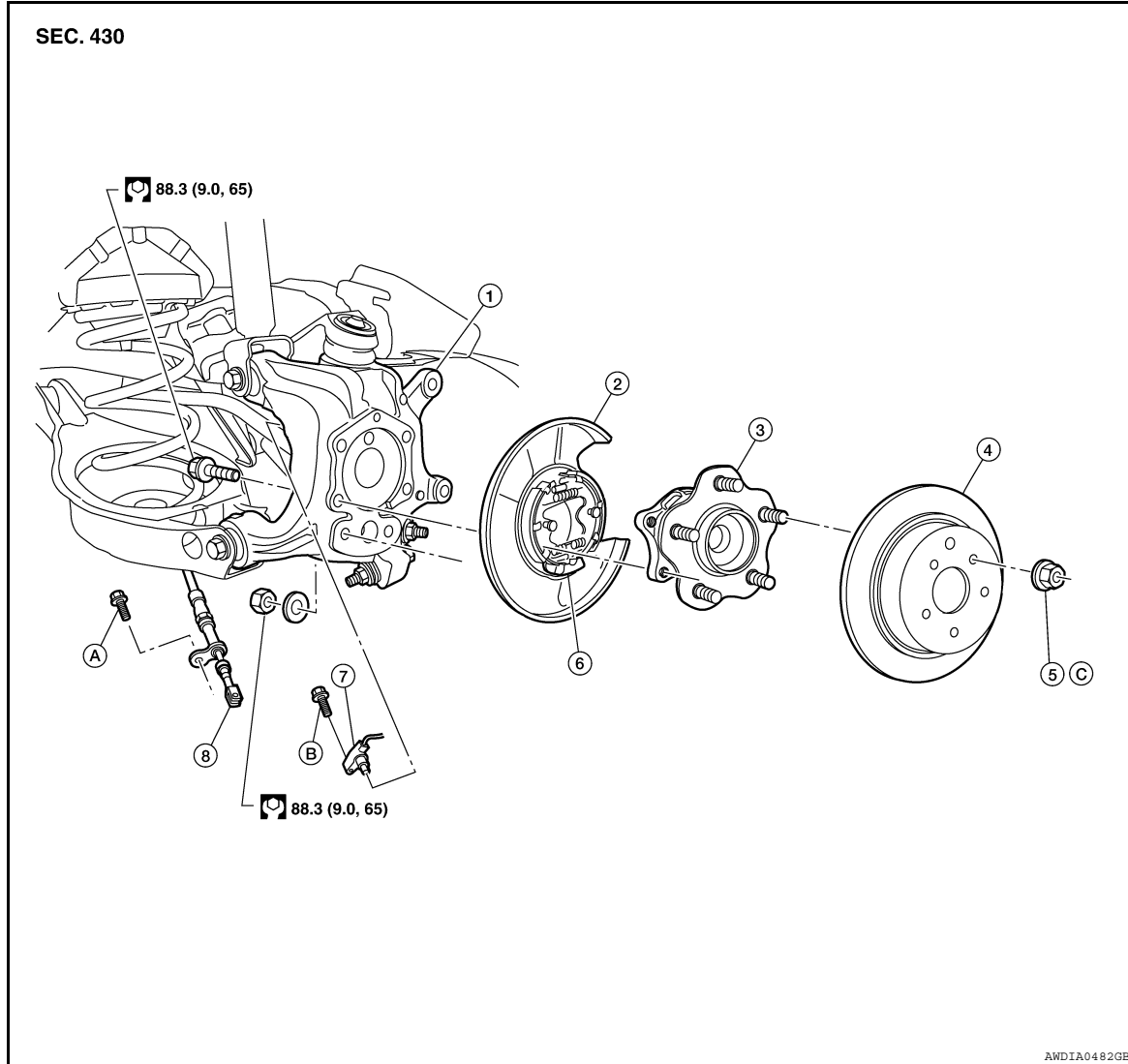

- | | | |
|----------------|------------------------|-----------------------|
| 1. Knuckle | 2. Baffle plate | 3. Wheel hub assembly |
| 4. Brake rotor | 5. Wheel nut | 6. Anchor block |
| 7. ABS sensor | 8. Parking brake cable | |
- A. Refer to [PB-8, "PEDAL TYPE : Exploded View"](#) (Pedal type), [PB-9, "LEVER TYPE : Exploded View"](#) (Lever type).
B. Refer to [BRC-57, "Removal and Installation"](#) (ABS), [BRC-163, "Removal and Installation"](#) (VDC/TCS/ABS).
C. Refer to [WT-65, "Adjustment"](#).

REMOVAL

CAUTION:

Wheel hub assembly does not require maintenance. If any of the following symptoms are noted, replace the wheel hub assembly.

- A growling noise is emitted from the wheel hub assembly while driving.
- The wheel hub assembly drags or turns roughly.

1. Remove the rear wheel and tire.
2. Remove the brake caliper assembly using power tool.
 - The brake hose does not need to be disconnected from the brake caliper.

WHEEL HUB

< ON-VEHICLE REPAIR >

- Suspend the brake caliper assembly using wire, do not stretch the brake hose.
 - Do not depress the brake pedal, or the caliper piston will pop out.
 - Do not twist the brake hose.
3. Remove the brake rotor.
 4. Remove the rear ABS sensor, then move it away from the wheel hub assembly.

CAUTION:

Failure to remove the ABS sensor may result in damage to the sensor wires and the sensor being inoperative.

5. Remove the wheel hub assembly from knuckle.

INSPECTION AFTER REMOVAL

Check for any deformity, cracks, or damage on the wheel hub assembly, replace if necessary.

INSTALLATION

Installation is in the reverse order of removal.

- Check that the wheel bearings operate smoothly.
- Check that the wheel hub bearing axial end play is within specification.

Axial end play : 0.1 mm (0.004 in) or less

- Install wheel and tire, tightening to specification. Refer to [WT-65](#), "[Adjustment](#)".

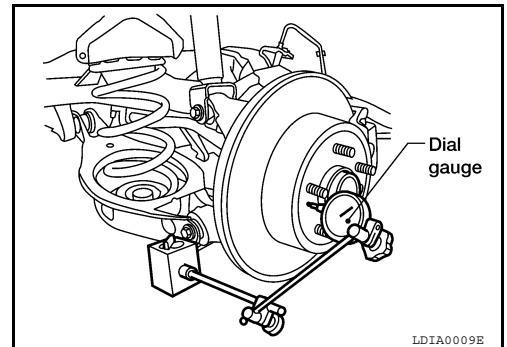

A
B
C
RAX
E
F
G
H
I
J
K
L
M
N
O
P

SERVICE DATA AND SPECIFICATIONS (SDS)

< SERVICE DATA AND SPECIFICATIONS (SDS)

SERVICE DATA AND SPECIFICATIONS (SDS)

SERVICE DATA AND SPECIFICATIONS (SDS)

Wheel Hub Bearing

INFOID:000000005796895

Axial end play	0.1 mm (0.004 in) or less
----------------	---------------------------