

SECTION BR
BRAKE SYSTEM

A
B
C
D
E

CONTENTS

PRECAUTION	3	BRAKE MASTER CYLINDER	10	BR
PRECAUTIONS	3	On Board Inspection	10	
Precaution for Supplemental Restraint System (SRS) "AIR BAG" and "SEAT BELT PRE-TENSIONER"	3	BRAKE TUBE AND HOSE	11	G
Necessary for Steering Wheel Rotation After Battery Disconnect	3	Hydraulic Circuit	11	
Precaution for Procedure without Cowl Top Cover.....	4	FRONT BRAKE	11	H
Precaution for Brake System	4	FRONT BRAKE : Inspection	11	
PREPARATION	5	REAR BRAKE	12	I
PREPARATION	5	REAR BRAKE : Inspection	12	
Special Service Tool	5	PERIODIC MAINTENANCE	13	J
Commercial Service Tool	5	BRAKE PEDAL	13	
SYSTEM DESCRIPTION	6	Inspection and Adjustment	13	K
NOISE, VIBRATION AND HARSHNESS (NVH) TROUBLESHOOTING	6	BRAKE FLUID	15	L
NVH Troubleshooting Chart	6	Inspection	15	
BASIC INSPECTION	7	Drain and Refill	15	M
FRONT DISC BRAKE	7	Bleeding Brake System	16	
BRAKE PAD	7	REMOVAL AND INSTALLATION	17	N
BRAKE PAD : Inspection	7	BRAKE PEDAL	17	
DISC ROTOR	7	Exploded View	17	O
DISC ROTOR : Inspection	7	Removal and Installation	17	
REAR DISC BRAKE	8	BRAKE TUBE AND HOSE	18	P
BRAKE PAD	8	Hydraulic Circuit	18	
BRAKE PAD : Inspection	8	FRONT BRAKE	18	
DISC ROTOR	8	FRONT BRAKE : Removal and Installation	18	
DISC ROTOR : Inspection	8	REAR BRAKE	20	
BRAKE BOOSTER	9	REAR BRAKE : Removal and Installation	20	
Inspection	9	BRAKE MASTER CYLINDER	22	
		Exploded View	22	
		Removal and Installation	22	
		BRAKE BOOSTER	24	
		Exploded View	24	
		Removal and installation	24	

VACUUM LINES	26	FRONT DISC BRAKE	38
Exploded View	26	BRAKE CALIPER ASSEMBLY	38
Removal and Installation	26	BRAKE CALIPER ASSEMBLY : Exploded View ...	38
Inspection After Removal	27	BRAKE CALIPER ASSEMBLY : Disassembly	38
FRONT DISC BRAKE	28	BRAKE CALIPER ASSEMBLY : Inspection After	
BRAKE PAD	28	Disassembly	39
BRAKE PAD : Exploded View	28	BRAKE CALIPER ASSEMBLY : Assembly	39
BRAKE PAD : Removal and Installation	28	REAR DISC BRAKE	41
BRAKE PAD : Brake Burnishing Procedure	30	BRAKE CALIPER ASSEMBLY	41
BRAKE CALIPER ASSEMBLY	30	BRAKE CALIPER ASSEMBLY : Exploded View ...	41
BRAKE CALIPER ASSEMBLY : Exploded View ...	30	BRAKE CALIPER ASSEMBLY : Disassembly	41
BRAKE CALIPER ASSEMBLY : Removal and In-		BRAKE CALIPER ASSEMBLY : Inspection After	
stallation	31	Disassembly	42
REAR DISC BRAKE	33	BRAKE CALIPER ASSEMBLY : Assembly	42
BRAKE PAD	33	SERVICE DATA AND SPECIFICATIONS	
BRAKE PAD : Exploded View	33	(SDS)	44
BRAKE PAD : Removal and Installation	33	SERVICE DATA AND SPECIFICATIONS	
BRAKE CALIPER ASSEMBLY	34	(SDS)	44
BRAKE CALIPER ASSEMBLY : Exploded View ...	35	General Specifications	44
BRAKE CALIPER ASSEMBLY : Removal and In-		Brake Pedal	44
stallation	35	Check Valve	45
UNIT DISASSEMBLY AND ASSEMBLY ...	38	Brake Booster	45
		Front Disc Brake	45
		Rear Disc Brake	45

PRECAUTIONS

< PRECAUTION >

PRECAUTION

PRECAUTIONS

Precaution for Supplemental Restraint System (SRS) "AIR BAG" and "SEAT BELT PRE-TENSIONER"

INFOID:000000006390847

The Supplemental Restraint System such as "AIR BAG" and "SEAT BELT PRE-TENSIONER", used along with a front seat belt, helps to reduce the risk or severity of injury to the driver and front passenger for certain types of collision. This system includes seat belt switch inputs and dual stage front air bag modules. The SRS system uses the seat belt switches to determine the front air bag deployment, and may only deploy one front air bag, depending on the severity of a collision and whether the front occupants are belted or unbelted. Information necessary to service the system safely is included in the SR and SB section of this Service Manual.

WARNING:

- To avoid rendering the SRS inoperative, which could increase the risk of personal injury or death in the event of a collision which would result in air bag inflation, all maintenance must be performed by an authorized NISSAN/INFINITI dealer.
- Improper maintenance, including incorrect removal and installation of the SRS, can lead to personal injury caused by unintentional activation of the system. For removal of Spiral Cable and Air Bag Module, see the SR section.
- Do not use electrical test equipment on any circuit related to the SRS unless instructed to in this Service Manual. SRS wiring harnesses can be identified by yellow and/or orange harnesses or harness connectors.

PRECAUTIONS WHEN USING POWER TOOLS (AIR OR ELECTRIC) AND HAMMERS

WARNING:

- When working near the Airbag Diagnosis Sensor Unit or other Airbag System sensors with the Ignition ON or engine running, DO NOT use air or electric power tools or strike near the sensor(s) with a hammer. Heavy vibration could activate the sensor(s) and deploy the air bag(s), possibly causing serious injury.
- When using air or electric power tools or hammers, always switch the Ignition OFF, disconnect the battery, and wait at least 3 minutes before performing any service.

Necessary for Steering Wheel Rotation After Battery Disconnect

INFOID:000000006390848

NOTE:

- Before removing and installing any control units, first turn the push-button ignition switch to the LOCK position, then disconnect both battery cables.
- After finishing work, confirm that all control unit connectors are connected properly, then re-connect both battery cables.
- Always use CONSULT to perform self-diagnosis as a part of each function inspection after finishing work. If a DTC is detected, perform trouble diagnosis according to self-diagnosis results.

This vehicle is equipped with a push-button ignition switch and a steering lock unit.

If the battery is disconnected or discharged, the steering wheel will lock and cannot be turned.

If turning the steering wheel is required with the battery disconnected or discharged, follow the procedure below before starting the repair operation.

OPERATION PROCEDURE

1. Connect both battery cables.

NOTE:

Supply power using jumper cables if battery is discharged.

2. Carry the Intelligent Key or insert it to the key slot and turn the push-button ignition switch to ACC position. (At this time, the steering lock will be released.)
3. Disconnect both battery cables. The steering lock will remain released with both battery cables disconnected and the steering wheel can be turned.
4. Perform the necessary repair operation.
5. When the repair work is completed, re-connect both battery cables. With the brake pedal released, turn the push-button ignition switch from ACC position to ON position, then to LOCK position. (The steering wheel will lock when the push-button ignition switch is turned to LOCK position.)

PRECAUTIONS

< PRECAUTION >

6. Perform self-diagnosis check of all control units using CONSULT.

Precaution for Procedure without Cowl Top Cover

INFOID:000000006390849

When performing the procedure after removing cowl top cover, cover the lower end of windshield with urethane, etc.

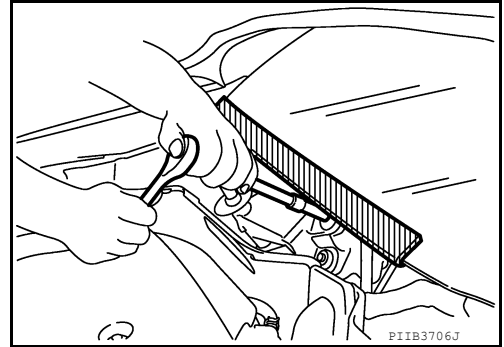

Precaution for Brake System

INFOID:000000006390850

- Clean dust on front brake and rear brake with a vacuum dust collector. Do not blow with compressed air.
- Recommended fluid is brake fluid "DOT 3".
- Never reuse drained brake fluid.
- Be careful not to splash brake fluid on painted areas; it may cause paint damage. If brake fluid is splashed on painted areas, wash it away with water immediately.
- Use clean brake fluid, to clean or wash all parts of master cylinder and disc brake caliper, etc.
- Never use mineral oils such as gasoline or kerosene. They will ruin rubber parts of the hydraulic system.
- Use flare nut torque wrench when installing brake tube.
- When installing brake tube and hose, be sure to check torque.
- Before working, turn ignition switch OFF and disconnect connectors of ABS actuator and electric unit (control unit) or battery cable from the negative terminal.
- Burnish the brake contact surfaces after refinishing or replacing rotors, after replacing pads, or if a soft pedal occurs at very low mileage. Refer to [BR-30. "BRAKE PAD : Brake Burnishing Procedure"](#).

WARNING:

- **Clean brake pads and shoes with a waste cloth, then wipe with a dust collector.**

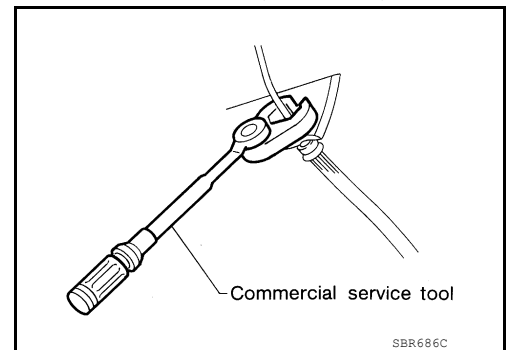

PREPARATION

< PREPARATION >

PREPARATION

PREPARATION

Special Service Tool

INFOID:000000006390851

The actual shapes of Kent-Moore tools may differ from those of special service tools illustrated here.

Tool number (Kent-Moore No.) Tool name	Description
— (J-46532) Brake and clutch pedal height measurement tool	Measuring brake pedal height
38-PFM90.5 (—) Pro-Cut PFM 90 On-Car Brake Lathe	Turning rotors

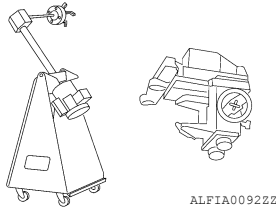
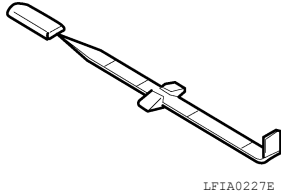

Commercial Service Tool

INFOID:000000006390852

Tool name	Description
1. Flare nut crowfoot 2. Torque wrench	Removing and installing brake tube and hose flare nuts a:10 mm (0.39 in) / 12 mm (0.47 in)
Power tool	Loosening nuts, screws and bolts

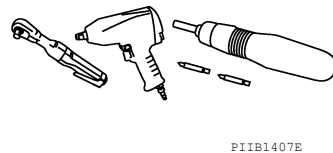
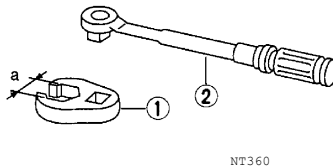

NOISE, VIBRATION AND HARSHNESS (NVH) TROUBLESHOOTING

< SYSTEM DESCRIPTION >

SYSTEM DESCRIPTION

NOISE, VIBRATION AND HARSHNESS (NVH) TROUBLESHOOTING

NVH Troubleshooting Chart

INFOID:000000006390853

Use the chart below to help you find the cause of the symptom. If necessary, repair or replace these parts.

Symptom		Possible cause and SUSPECTED PARTS																		
		Pads - damaged	Pads - uneven wear	Shims damaged	Rotor imbalance	Rotor damage	Rotor runout	Rotor deformation	Rotor deflection	Rotor rust	Rotor thickness variation	Drum out of round	WHEEL HUB	SUSPENSION	AXLE	TIRES	ROAD WHEEL	DRIVE SHAFT	STEERING	
Noise	Noise	x	x	x																
	Shake				x							x	x	x	x	x	x	x	x	x
	Shimmy, Shudder				x	x	x	x	x	x	x		x	x	x	x	x	x	x	x
Reference page		BR-7, BR-8	BR-7, BR-8	BR-7, BR-8	—	—	BR-7, BR-8	—	—	—	BR-7, BR-8	—	FAX-2, RAX-4	FSU-4	FAX-2 (front axle), RAX-4 (rear axle)	WT-59, "NVH Troubleshooting Chart"	WT-59, "NVH Troubleshooting Chart"	FAX-2, "NVH Troubleshooting Chart"	ST-5, "NVH Troubleshooting Chart"	

x: Applicable

FRONT DISC BRAKE

< BASIC INSPECTION >

BASIC INSPECTION

FRONT DISC BRAKE

BRAKE PAD

BRAKE PAD : Inspection

INFOID:000000006390854

PAD WEAR

Check pad thickness from an inspection hole on cylinder body.
Check using a scale if necessary.

Standard thickness : Refer to [BR-45, "Front Disc Brake"](#).

Wear limit thickness : Refer to [BR-45, "Front Disc Brake"](#).

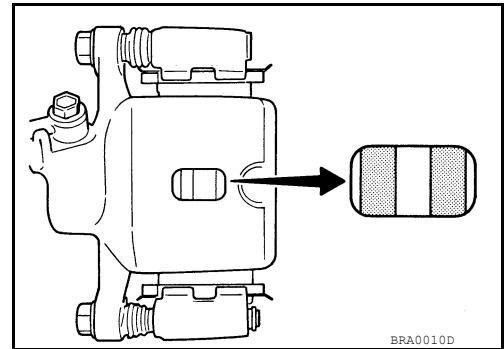

DISC ROTOR

DISC ROTOR : Inspection

INFOID:000000006390855

VISUAL

Check surface of disc rotor for uneven wear, cracks, and serious damage. Replace if necessary.

RUNOUT

1. Attach the disc rotor to wheel hub using wheel nuts at two or more positions.
2. Inspect runout using a dial gauge. Set the dial gauge to measure at 10 mm (0.39 in) inside the disc edge.

Maximum runout : Refer to [BR-45, "Front Disc Brake"](#).
(with it attached to the vehicle)

NOTE:

Before measuring, make sure that wheel bearing axial end play is within the specification. Refer to [FAX-6, "Inspection"](#).

3. When runout exceeds limit value, displace mounting positions of disc rotor by one hole. And then find a position of the minimum value for runout.
4. If runout is outside the specified value after performing the above operation, turn the disc rotor using Tool.

Tool number : 38-PFM90.5

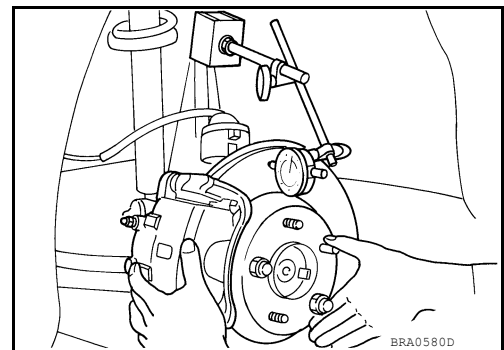

THICKNESS

Check thickness of the disc rotor using a micrometer. Replace disc rotor if thickness is under the wear limit.

Standard thickness : Refer to [BR-45, "Front Disc Brake"](#).

Wear limit thickness : Refer to [BR-45, "Front Disc Brake"](#).

Thickness variation (Measured at 8 positions) : Refer to [BR-45, "Front Disc Brake"](#).

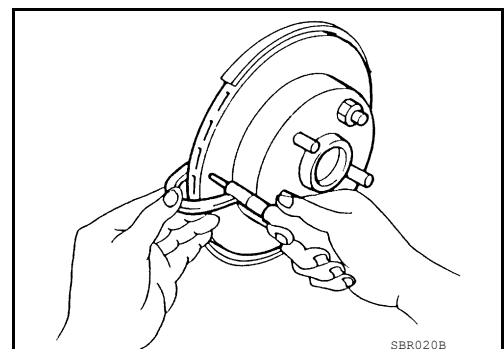

A
B
C
D
E
BR
G
H
I
J
K
L
M
N
O
P

REAR DISC BRAKE

< BASIC INSPECTION >

REAR DISC BRAKE

BRAKE PAD

BRAKE PAD : Inspection

INFOID:000000006390856

PAD WEAR

Check pad thickness from an inspection hole on cylinder body.
Check using a scale if necessary.

Standard thickness : Refer to [BR-45, "Rear Disc Brake"](#).

Wear limit thickness : Refer to [BR-45, "Rear Disc Brake"](#).

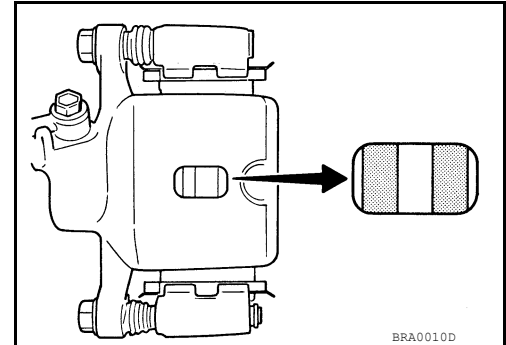

DISC ROTOR

DISC ROTOR : Inspection

INFOID:000000006390857

VISUAL

Check surface of disc rotor for uneven wear, cracks, and serious damage. Replace if necessary.

RUNOUT

1. Attach the disc rotor to wheel hub using wheel nuts at two or more positions.
2. Inspect runout using dial gauge. Set the dial gauge to measure at 10 mm (0.39 in) inside disc edge.

Maximum runout : Refer to [BR-45, "Rear Disc Brake"](#).
(with it attached to the vehicle)

NOTE:

Before measuring, make sure that wheel bearing axial end play is within the specification. Refer to [FAX-6, "Inspection"](#).

3. When runout exceeds limit value, displace mounting positions of disc rotor by one hole. And then find a position of the minimum value for runout.
4. If runout is outside the specified value after performing the above operation, turn the disc rotor using Tool.

Tool number : 38-PFM90.5

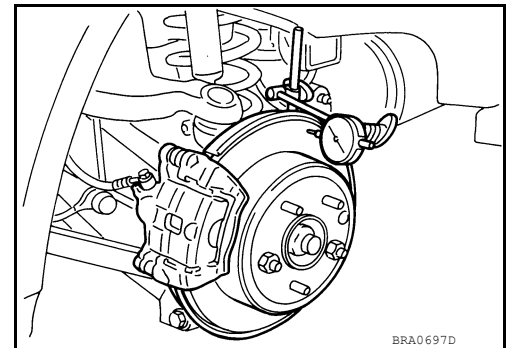

THICKNESS

Check the thickness of the disc rotor using a micrometer. Replace disc rotor if the thickness is under the wear limit.

Standard thickness : Refer to [BR-45, "Rear Disc Brake"](#).

Wear limit thickness : Refer to [BR-45, "Rear Disc Brake"](#).

Thickness variation (measured at 8 positions) : Refer to [BR-45, "Rear Disc Brake"](#).

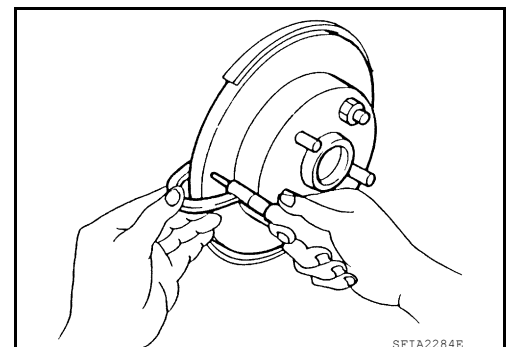

BRAKE BOOSTER

< BASIC INSPECTION >

BRAKE BOOSTER

Inspection

INFOID:000000006390858

OPERATION

With engine stopped, change vacuum to atmospheric pressure by depressing brake pedal several times. Then with brake pedal fully depressed, start engine and when vacuum pressure reaches the standard, make sure that clearance between brake pedal and floor panel decreases.

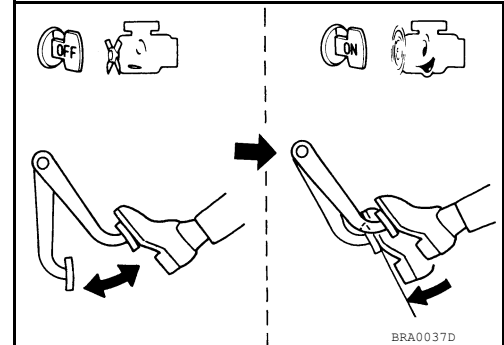

AIR TIGHT

• Run engine at idle for approximately 1 minute, and stop it after applying vacuum to booster. Depress brake pedal normally to change vacuum to atmospheric pressure. Make sure that distance at intervals of 5 seconds between brake pedal and floor panel gradually increases.

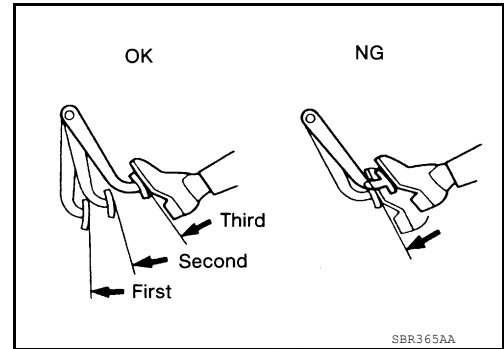

• Depress brake pedal while engine is running, and stop engine with pedal depressed. The pedal stroke should not change after holding pedal down for 30 seconds.

BRAKE MASTER CYLINDER

< BASIC INSPECTION >

BRAKE MASTER CYLINDER

On Board Inspection

INFOID:000000006390859

LEAK INSPECTION

Check for leaks in the master cylinder installation surface, reservoir tank installation surface, and brake pipe and hose connections.

BRAKE TUBE AND HOSE

< BASIC INSPECTION >

BRAKE TUBE AND HOSE

Hydraulic Circuit

INFOID:000000006390860

Four Channel Hydraulic Circuit

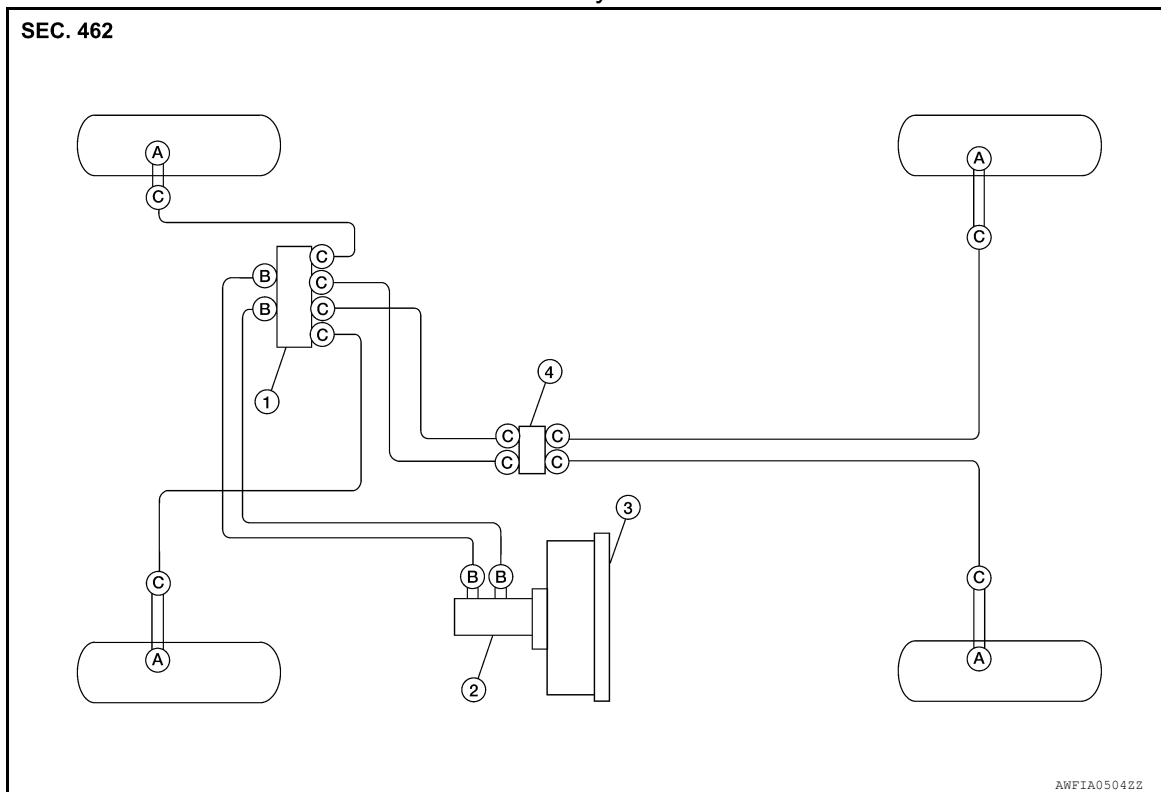

- | | | |
|---|--|---|
| 1. ABS actuator and electric unit (control unit) | 2. Master cylinder | 3. Booster |
| 4. Connector | A. Union bolt
18.2 N·m (1.9 kg-m, 13 ft-lb) | B. Flare nut M12
18.2 N·m (1.9 kg-m, 13 ft-lb) |
| C. Flare nut M10
16.2 N·m (1.7 kg-m, 12 ft-lb) | | |

CAUTION:

- All hoses and piping (tubes) must be free from excessive bending, twisting and pulling.
- Make sure there is no interference with other parts when turning steering both clockwise and counterclockwise.
- The brake piping is an important safety part. If a brake fluid leak is detected, always disassemble the parts. Replace applicable part with a new one, if necessary.
- Be careful not to splash brake fluid on painted areas; it may cause paint damage. If brake fluid is splashed on painted areas, wash it away with water immediately.
- Do not bend or twist brake hose sharply, or strongly pull it.
- When removing components, cover connections so that no dirt, dust, or other foreign matter gets in.
- Do not reuse drained brake fluid.
- After installation of the ABS actuator and electric unit (control unit), refill brake system with new brake fluid. Then bleed the air from the system. Refer to [BR-16, "Bleeding Brake System"](#).

FRONT BRAKE

FRONT BRAKE : Inspection

INFOID:000000006390861

INSPECTION AFTER REMOVAL

CAUTION:

- Brake tubes and hoses are important safety parts. Always disassemble the parts and retighten their fittings, if a brake fluid leak is detected. Replace applicable part with a new one, if damaged part is detected.

BRAKE TUBE AND HOSE

< BASIC INSPECTION >

1. Check brake lines (tubes and hoses) and connections for fluid leakage, damage, twists, deformation, contacts with other parts, and loose connections. Replace any damage parts.
2. While depressing brake pedal under a force of 785 N (80 kg-f, 177 lb-f) with engine running for approximately 5 seconds, check each part for fluid leakage.

REAR BRAKE

REAR BRAKE : Inspection

INFOID:000000006390862

INSPECTION AFTER REMOVAL

CAUTION:

Brake tubes and hoses are important safety parts. Always disassemble the parts and retighten their fittings, if a brake fluid leak is detected. Replace applicable part with a new one, if damaged part is detected.

1. Check brake lines (tubes and hoses) and connections for fluid leakage, damage, twists, deformation, contacts with other parts, and loose connections. Replace any damage parts.
2. While depressing brake pedal under a force of 785 N (80 kg-f, 177 lb-f) with engine running for approximately 5 seconds, then check each part for fluid leakage.

BRAKE PEDAL

< PERIODIC MAINTENANCE >

PERIODIC MAINTENANCE

BRAKE PEDAL

Inspection and Adjustment

INFOID:000000006390863

INSPECTION

1. Inspect the brake pedal height (H) from the floor using Tool at a 90° angle to the floor.

Tool number : — (J-46532)

2. Adjust the brake pedal height to specifications.

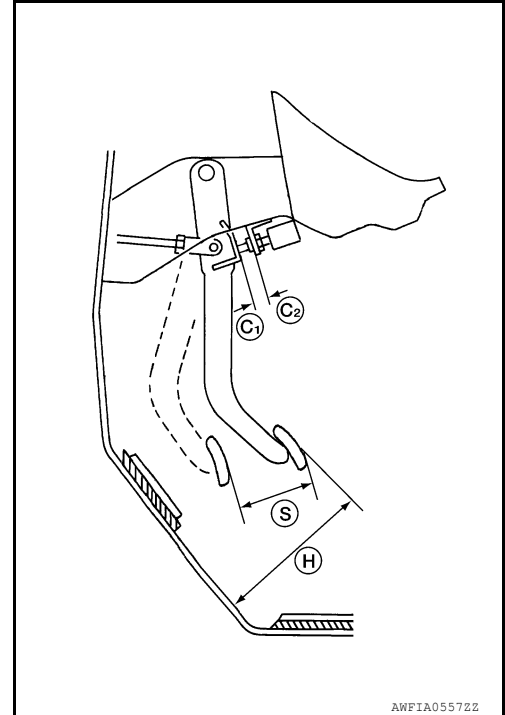

Brake Pedal Specifications

Brake pedal height (H) (from dash lower panel top surface)	CVT	Refer to BR-44, "Brake Pedal" .
	M/T	Refer to BR-44, "Brake Pedal" .
Brake pedal full stroke (S)	CVT	Refer to BR-44, "Brake Pedal" .
	M/T	Refer to BR-44, "Brake Pedal" .
Clearance between stopper bracket (C1) and threaded end of the stop lamp switch and ASCD cancel switch (C2).		Refer to BR-44, "Brake Pedal" .

ADJUSTMENT

BRAKE PEDAL

< PERIODIC MAINTENANCE >

1. Loosen the stop lamp switch and ASCD cancel switch by turning it counterclockwise by 45°.
2. Loosen lock nut (A) on the input rod, then turn input rod to adjust the brake pedal height to specification, and tighten lock nut (A).

Lock nut torque Refer to [BR-45, "Brake Booster"](#)

CAUTION:

Make sure the threaded end of input rod stays inside clevis.

3. With the pedal pulled up and held by hand, press the stop lamp switch and ASCD cancel switch until the threaded end contacts the stopper.
4. With the threaded end of the stop lamp switch and ASCD cancel switch contacting the bracket, rotate the switch clockwise by 45° to secure.

CAUTION:

Make sure that the clearance (C) between bracket and end of stop lamp switch and brake switch is within the standard.

Refer to [BR-13, "Inspection and Adjustment"](#).

5. Check the brake pedal for smooth operation.

CAUTION:

Make sure that stop lamps are off when the brake pedal is released.

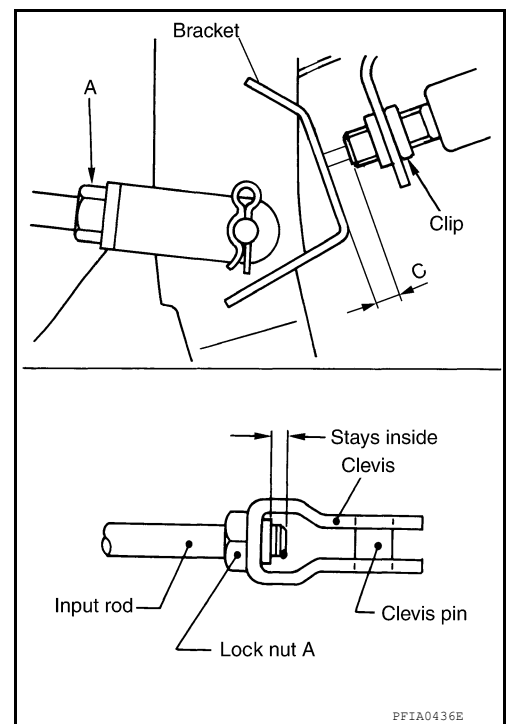

PFIA0436E

BRAKE FLUID

< PERIODIC MAINTENANCE >

BRAKE FLUID

Inspection

INFOID:000000006390864

BRAKE FLUID LEVEL

- Make sure that a brake fluid level in reservoir tank is within the specified range between the MAX and MIN lines.
- Visually check around reservoir tank for fluid leaks.
- If the level is excessively low, check brake system for leaks.
- Release parking brake pedal and see if brake warning lamp goes off. If not, check brake system for fluid leaks.

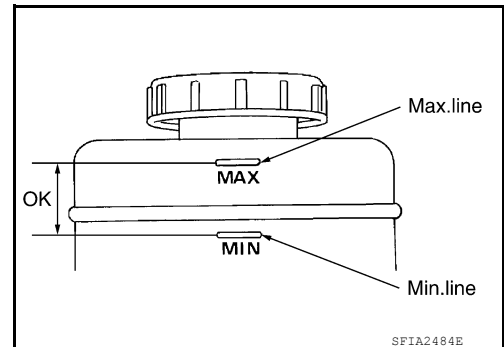

BRAKE LINE

CAUTION:

If leakage occurs around joints, retighten or, if necessary, replace damaged parts.

1. Check brake lines (tubes and hoses) for cracks, deterioration or other damage. Replace any damaged parts.
2. Check for oil leaks by fully depressing brake pedal while the engine is running.

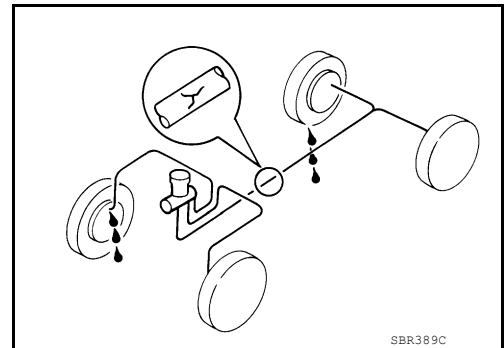

Drain and Refill

INFOID:000000006390865

DRAINING

CAUTION:

- Be careful not to splash brake fluid on painted areas; it may cause paint damage. If brake fluid is splashed on painted areas, wash it away with water immediately.
- Before working, disconnect connectors of ABS actuator and electric unit (control unit) or battery cable from the negative terminal.

1. Connect a vinyl tube to bleed valve.
2. Depress brake pedal, loosen bleed valve, and gradually remove brake fluid.

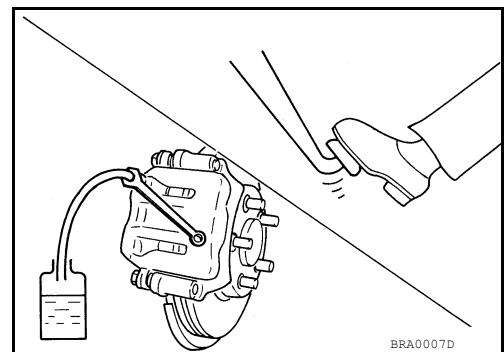

REFILLING

CAUTION:

- Refill with new brake fluid "DOT 3".
- Never reuse drained brake fluid.

A
B
C
D
E
BR
G
H
I
J
K
L
M
N
O
P

BRAKE FLUID

< PERIODIC MAINTENANCE >

- Before working, disconnect connectors of ABS actuator and electric unit (control unit) or battery cable from the negative terminal.
1. Make sure there is no foreign material in the reservoir tank, and refill with new brake fluid.
 2. Loosen bleed valve, depress brake pedal slowly to full stroke and then release it. Repeat the procedure every 2 or 3 seconds until the new brake fluid comes out, then close the bleed valve while depressing the pedal. Repeat the same work for each wheel.
 3. Bleed air. Refer to [BR-16. "Bleeding Brake System"](#).

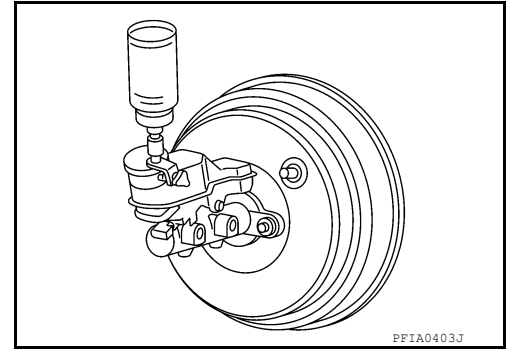

INFOID:000000006390866

Bleeding Brake System

BLEEDING BRAKE SYSTEM

CAUTION:

- While bleeding, pay attention to master cylinder fluid level.
 - Before working, disconnect connectors of ABS actuator and electric unit (control unit) or battery cable from the negative terminal.
1. Connect a vinyl tube to rear right brake caliper bleed valve.
 2. Fully depress brake pedal 4 or 5 times.
 3. With brake pedal depressed, loosen bleed valve to bleed air in brake line, and then tighten it immediately.
 4. Repeat steps 2 and 3 until all of the air is out of the brake line.
 5. Tighten the bleed valve to the specified torque. Refer to front disc brake: [BR-30. "BRAKE CALIPER ASSEMBLY : Exploded View"](#), rear disc brake: [BR-35, "BRAKE CALIPER ASSEMBLY : Exploded View"](#).
 6. From step 1 to 5, with master cylinder reservoir tank filled at least half way, bleed air from brake hydraulic line bleed valves in the following order:
Rear right brake→Front left brake→Rear left brake→Front right brake

BRAKE PEDAL

< REMOVAL AND INSTALLATION >

REMOVAL AND INSTALLATION

BRAKE PEDAL

Exploded View

INFOID:000000006390867

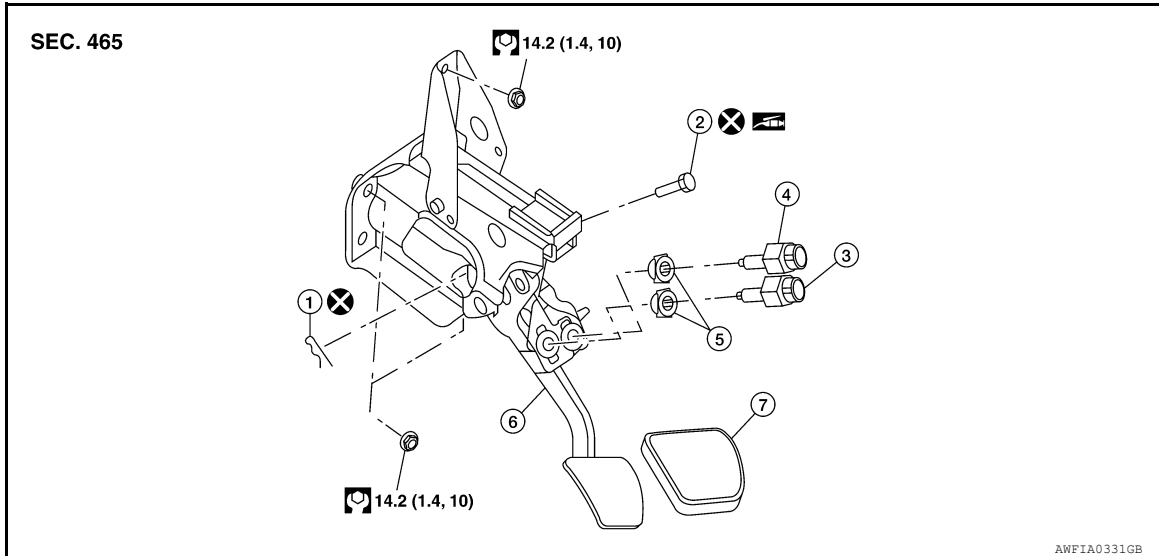

- | | | |
|-----------------------|---------------|-------------------------|
| 1. Snap pin | 2. Clevis pin | 3. Stop lamp switch |
| 4. ASCD cancel switch | 5. Clip | 6. Brake pedal assembly |
| 7. Brake pedal pad | | |

NOTE:

The clevis pin must be installed from the right side as shown above.

Removal and Installation

INFOID:000000006390868

REMOVAL

1. Remove the instrument lower cover (LH) and lower knee protector (LH). Refer to [IP-11, "Exploded View"](#).
2. Remove the console side finisher (LH). Refer to [IP-22, "Exploded View"](#).
3. Remove the accelerator pedal. Refer to [ACC-4, "Exploded View"](#).
4. Disconnect the stop lamp switch and ASCD cancel switch connector.
5. Remove the stop lamp switch and ASCD cancel switch from the brake pedal assembly.
6. Remove the snap pin and clevis pin to disconnect the brake booster clevis from the brake pedal assembly.
CAUTION:
Do not reuse the snap pin and clevis pin.
7. Remove the brake booster clevis from the input rod.
8. Disconnect the steering column assembly pinch bolt to position the steering column assembly aside. Refer to [ST-17, "Exploded View"](#).
9. Remove the brake pedal assembly nuts.
10. Remove the brake pedal assembly.

INSTALLATION

Installation is in the reverse order of removal.

- Tighten the lock nut to the specified torque. Refer to [BR-17, "Exploded View"](#).
- Adjust the brake pedal height after installing the brake pedal assembly. Refer to [BR-44, "Brake Pedal"](#).

CAUTION:

Do not reuse the snap pin and clevis pin.

BRAKE TUBE AND HOSE

< REMOVAL AND INSTALLATION >

BRAKE TUBE AND HOSE

Hydraulic Circuit

INFOID:000000006390869

Four Channel Hydraulic Circuit

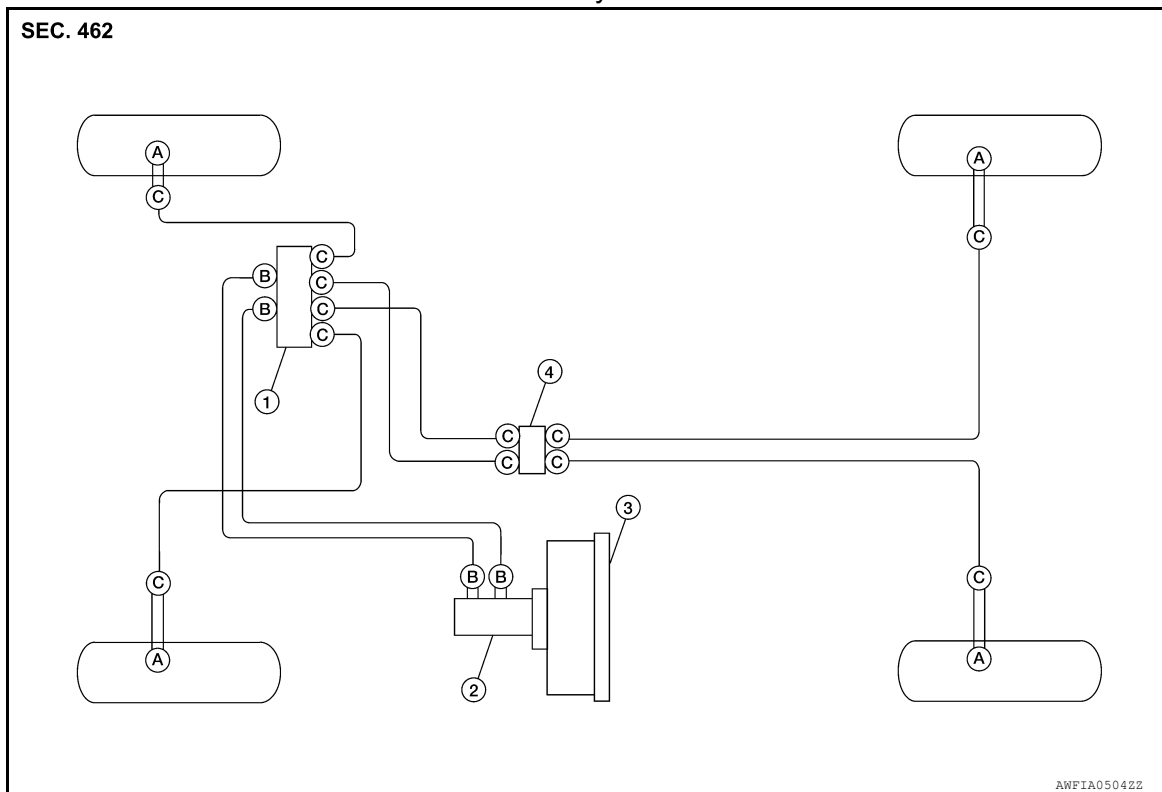

- | | | |
|---|--|---|
| 1. ABS actuator and electric unit (control unit) | 2. Master cylinder | 3. Booster |
| 4. Connector | A. Union bolt
18.2 N·m (1.9 kg-m, 13 ft-lb) | B. Flare nut M12
18.2 N·m (1.9 kg-m, 13 ft-lb) |
| C. Flare nut M10
16.2 N·m (1.7 kg-m, 12 ft-lb) | | |

CAUTION:

- All hoses and piping (tubes) must be free from excessive bending, twisting and pulling.
- Make sure there is no interference with other parts when turning steering both clockwise and counterclockwise.
- The brake piping is an important safety part. If a brake fluid leak is detected, always disassemble the parts. Replace applicable part with a new one, if necessary.
- Be careful not to splash brake fluid on painted areas; it may cause paint damage. If brake fluid is splashed on painted areas, wash it away with water immediately.
- Do not bend or twist brake hose sharply, or strongly pull it.
- When removing components, cover connections so that no dirt, dust, or other foreign matter gets in.
- Do not reuse drained brake fluid.
- After installation of the ABS actuator and electric unit (control unit), refill brake system with new brake fluid. Then bleed the air from the system. Refer to [BR-16, "Bleeding Brake System"](#).

FRONT BRAKE

FRONT BRAKE : Removal and Installation

INFOID:000000006390870

REMOVAL

CAUTION:

- Be careful not to splash brake fluid on painted areas; it may cause paint damage. If brake fluid is splashed on painted areas, wash it away with water immediately.
- Cover the open end of brake tubes and hoses when disconnecting to prevent entrance of dirt.

BRAKE TUBE AND HOSE

< REMOVAL AND INSTALLATION >

NOTE:

When removing components such as hoses, tubes/lines, etc., cap or plug openings to prevent fluid from spilling.

1. Remove brake reservoir cap.
2. Remove the wheel and tire using power tool.
3. Disconnect the brake hose from brake tube, using a flare nut wrench and then remove the lock plate.

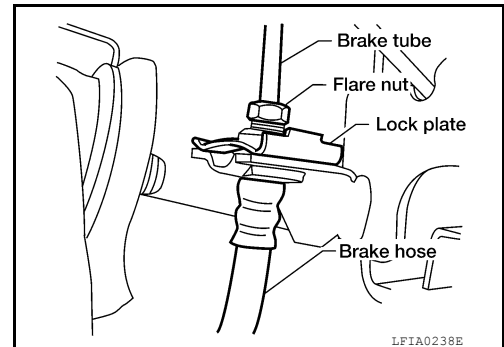

4. Remove the union bolt (A) and remove brake hose from caliper assembly. Discard the copper sealing washers.

- Protrusions (B)

CAUTION:

Do not reuse copper sealing washers.

5. Remove the brake hose.

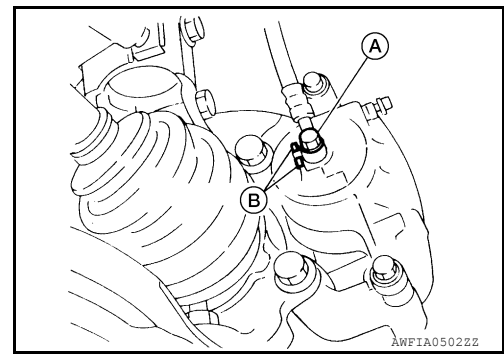

INSTALLATION

CAUTION:

- All brake hoses and tubes must be free from excessive bending, twisting and pulling.
- Make sure that there is no interference with other parts when turning steering both clockwise and counterclockwise.
- Brake tubes and hoses are an important safety part. Always disassemble the parts and retighten their fittings, if a brake fluid leak is detected. Replace applicable part with a new one, if damaged part is detected.
- Be careful not to splash brake fluid on painted areas; it may cause paint damage. If brake fluid is splashed on painted areas, wash it away with water immediately.
- Refill with new brake fluid "DOT 3".
- Never reuse drained brake fluid.

1. Assemble the union bolt (A) and new copper sealing washers (1) on the brake hose.

CAUTION:

Do not reuse copper sealing washers.

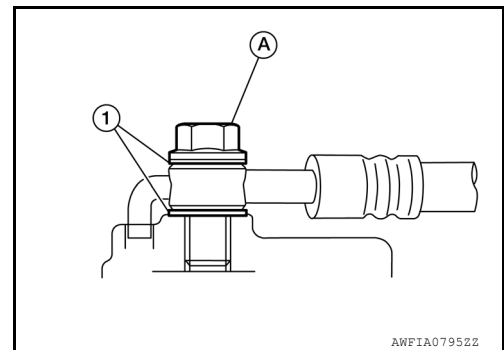

BRAKE TUBE AND HOSE

< REMOVAL AND INSTALLATION >

2. Install brake hose by aligning the brake hose with the protrusion (B) on brake caliper assembly as shown. Tighten union bolt (A) to the specified torque. Refer to [BR-18. "Hydraulic Circuit"](#).

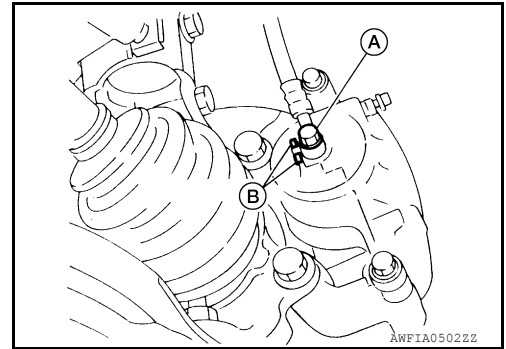

3. Connect brake hose to brake tube, partially tighten flare nut by hand as much as possible, then secure it to the bracket with lock plate.
4. Using a flare nut torque wrench, tighten flare nut to the specified torque. Refer to [BR-18. "Hydraulic Circuit"](#).
5. Refill brake fluid and bleed air. Refer to [BR-16. "Bleeding Brake System"](#).

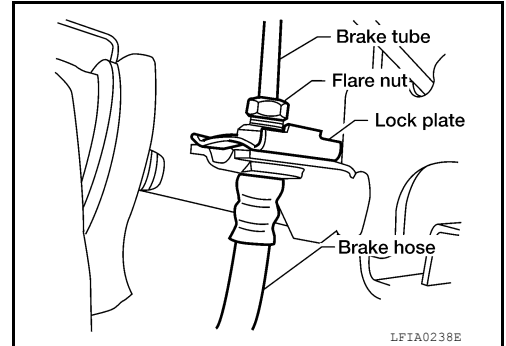

6. Install the wheel and tire. Refer to [WT-65. "Adjustment"](#).

REAR BRAKE

REAR BRAKE : Removal and Installation

INFOID:000000006390871

REMOVAL

CAUTION:

- Be careful not to splash brake fluid on painted areas; it may cause paint damage. If brake fluid is splashed on painted areas, wash it away with water immediately.
- Cover the open end of brake tubes and hoses when disconnecting to prevent entrance of dirt.

NOTE:

When removing components such as hoses, tubes/lines, etc., cap or plug openings to prevent fluid from spilling.

1. Remove brake reservoir cap.
2. Remove the wheel and tire using power tool.
3. Disconnect the brake hose from brake tube, using a flare nut wrench and then remove the lock plate.

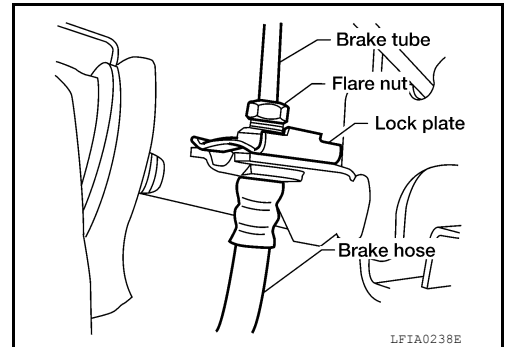

BRAKE TUBE AND HOSE

< REMOVAL AND INSTALLATION >

- Remove the union bolt (A), and then remove brake hose from brake caliper assembly and discard the copper sealing washers.

CAUTION:

Do not reuse copper sealing washers.

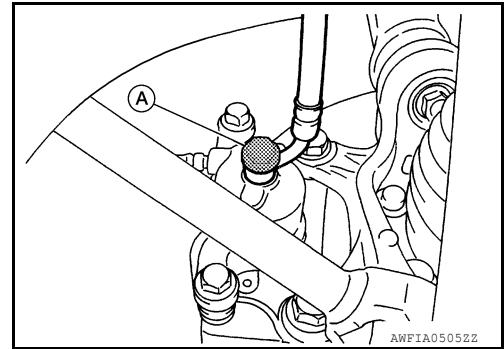

- Remove the brake hose.

INSTALLATION

CAUTION:

- All brake hoses and tubes must be free from excessive bending, twisting and pulling.
- Make sure that there is no interference with other parts when turning steering both clockwise and counterclockwise.
- Brake tubes and hoses are an important safety part. Always disassemble the parts and retighten their fittings, if a brake fluid leak is detected. Replace applicable part with a new one, if damaged part is detected.
- Be careful not to splash brake fluid on painted areas; it may cause paint damage. If brake fluid is splashed on painted areas, wash it away with water immediately.
- Refill with new brake fluid "DOT 3".
- Never reuse drained brake fluid.

- Assemble the union bolt (A) and the new copper sealing washers (1) on the brake hose.

CAUTION:

Do not reuse copper sealing washers.

- Attach L-shape metal fitting of the brake hose to brake caliper assembly positioning hole, and then tighten union bolt to the specified torque. Refer to [BR-18, "Hydraulic Circuit"](#),

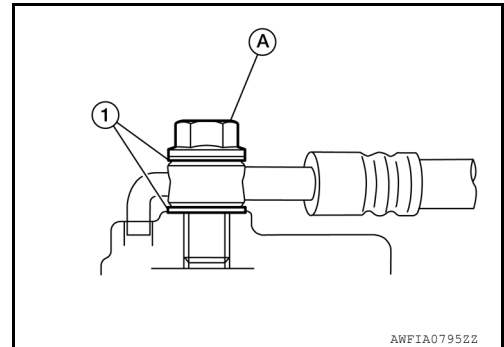

- Connect brake hose to brake tube, partially tighten flare nut by hand as much as possible, then secure it to the bracket with lock plate.
- Using a flare nut torque wrench, tighten flare nut to the specified torque. Refer to [BR-18, "Hydraulic Circuit"](#).
- Refill brake fluid and bleed air. Refer to [BR-16, "Bleeding Brake System"](#).

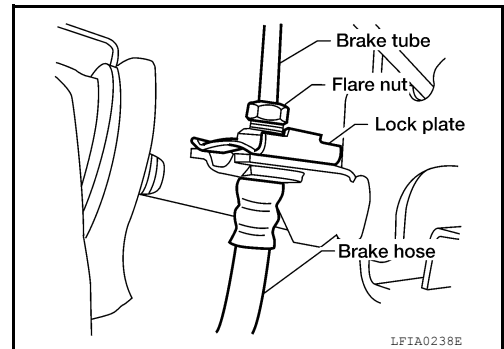

- Install the wheel and tire. Refer to [WT-65, "Adjustment"](#).

BRAKE MASTER CYLINDER

< REMOVAL AND INSTALLATION >

BRAKE MASTER CYLINDER

Exploded View

INFOID:000000006390872

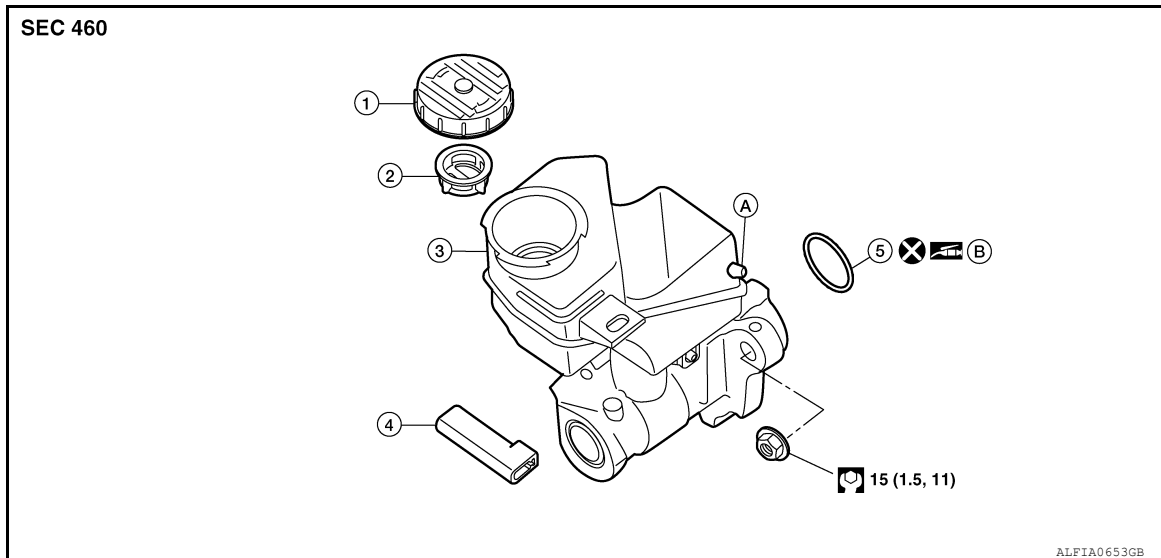

- | | | |
|--|------------------------|-----------------------------|
| 1. Reservoir cap | 2. Oil strainer (blue) | 3. Master cylinder assembly |
| 4. Brake fluid level switch | 5. O-ring | A. To clutch (if equipped) |
| B. PBC (Poly Butyl Cuprysil) grease or silicone-based grease | | |

Removal and Installation

INFOID:000000006390873

CAUTION:

- Be careful not to splash brake fluid on painted areas; it may cause paint damage. If brake fluid is splashed on painted areas, wash it away with water immediately.
- Never scratch the piston of master cylinder when installing/removing because the piston is exposed. Check for any dust on the piston, and wash with brake fluid if needed.
- Hold the master cylinder body when handing the master cylinder assembly. Never hold the piston because the piston might become detached if pulled strongly.
- Refill the reservoir tank with new brake fluid "DOT 3".
- Never reuse drained brake fluid.
- Do not reuse master cylinder O-ring.

NOTE:

When removing components such as hoses, tubes/lines, etc., cap or plug openings to prevent fluid from spilling.

REMOVAL

1. Drain the brake fluid. Refer to [BR-15. "Drain and Refill"](#).
2. Remove the engine cover.
3. Remove air cleaner assembly and air ducts. Refer to [EM-25. "Removal and Installation"](#) (QR25DE), [EM-131. "Removal and Installation"](#) (VQ35DE).
4. Disconnect the brake fluid level switch harness connector.
5. Disconnect the clutch fluid hose (if equipped).

BRAKE MASTER CYLINDER

< REMOVAL AND INSTALLATION >

6. Disconnect the master cylinder brake tubes using a suitable tool.

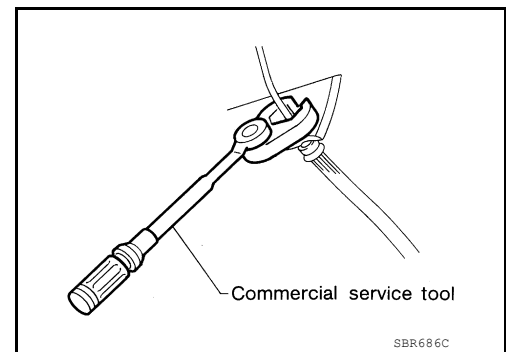

7. Remove the master cylinder nuts and remove the master cylinder assembly.

INSTALLATION

Installation is in the reverse order of removal.

- Apply PBC (Poly Butyl Cuprysil) grease or silicone-based grease to brake booster at (A) position as shown. Be sure the O-ring is in proper position prior to installing the master cylinder to the brake booster.

CAUTION:

Do not reuse O-ring.

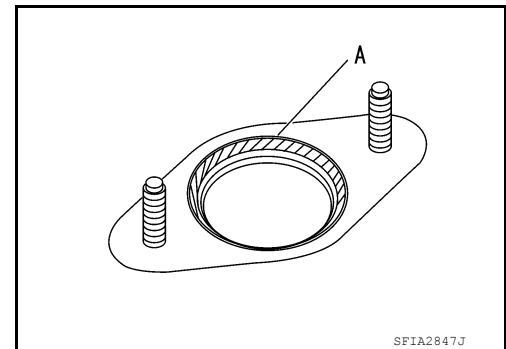

- Tighten brake tube flare nut to the specified torque using a suitable tool. Refer to [BR-18, "Hydraulic Circuit"](#).
- Refill with new brake fluid and bleed air. Refer to [BR-16, "Bleeding Brake System"](#).
- Bleed hydraulic clutch system if equipped. Refer to [CL-7, "Air Bleeding Procedure"](#).

BRAKE BOOSTER

< REMOVAL AND INSTALLATION >

BRAKE BOOSTER

Exploded View

INFOID:000000006390874

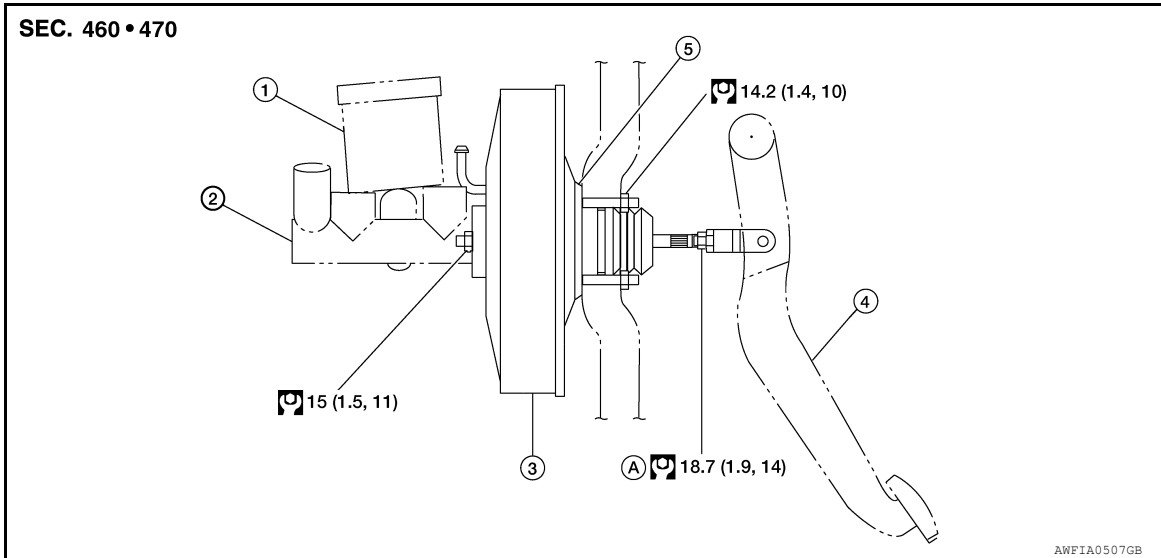

- | | | |
|-------------------|--------------------|------------------|
| 1. Reservoir tank | 2. Master cylinder | 3. Brake booster |
| 4. Brake pedal | 5. Gasket | A. Lock nut |

Removal and installation

INFOID:000000006390875

CAUTION:

- Be careful not to deform or bend brake tube while removing and installing brake booster.
- Replace clevis pin if it is damaged.
- Be careful not to damage brake booster stud bolt threads. If brake booster is tilted during installation, the dash panel may damage the threads.

REMOVAL

1. Disconnect negative battery terminal.
2. Remove the air cleaner assembly. Refer to [EM-25, "Removal and Installation"](#) (QR25DE), [EM-131, "Removal and Installation"](#) (VQ35DE).
3. Disconnect the clutch hose from the reservoir tank (if equipped).
4. Remove the brake master cylinder. Refer to [BR-22, "Removal and Installation"](#).
5. Release the fuel pressure and disconnect the fuel lines at the main connection. Refer to [EC-323, "Inspection"](#) (QR25DE), [EC-701, "Inspection"](#) (VQ35DE).
6. Remove the cowl top and cowl top extension. Refer to [EXT-45, "Removal and Installation"](#) (Sedan), [EXT-21, "Removal and Installation"](#) (Coupe).
7. Remove the strut tower bar. Refer to [FSU-13, "Exploded View"](#).
8. Remove the vacuum hose from the brake booster. Refer to [BR-26, "Exploded View"](#).
9. Remove the accelerator pedal (VQ35DE only). Refer to [ACC-4, "Removal and Installation"](#).
10. Remove the brake pedal (VQ35DE only). Refer to [BR-17, "Removal and Installation"](#).

BRAKE BOOSTER

< REMOVAL AND INSTALLATION >

11. Remove the snap pin and clevis pin from inside the vehicle (QR25DE only).
12. Remove brake booster from the dash panel on the engine room side.

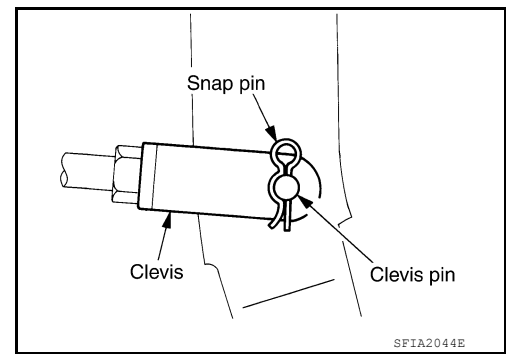

INSTALLATION

1. Loosen lock nut to adjust input rod length so that length (B) is at the specified value.

Length (B) : Refer to [BR-45, "Brake Booster"](#).

2. After adjusting (B), temporarily tighten lock nut to install booster assembly. Make sure that a gasket is installed between the brake booster and dash panel.

CAUTION:

Always install a gasket between the brake booster and dash panel.

3. Install the brake pedal (VQ35DE only). Refer to [BR-17, "Removal and Installation"](#).
4. Install the accelerator pedal (VQ35DE only). Refer to [ACC-4, "Removal and Installation"](#).
5. Install a new snap pin and a new clevis pin (QR25DE only).

CAUTION:

Do not reuse both snap pin and clevis pin.

NOTE:

The clevis pin must be installed from the right side of the vehicle.

6. Install the vacuum hose on the brake booster. Refer to [BR-26, "Exploded View"](#).
7. Install the strut tower bar. Refer to [FSU-13, "Exploded View"](#).
8. Install the cowl top and cowl top extension. Refer to [EXT-45, "Removal and Installation"](#) (Sedan), [EXT-21, "Removal and Installation"](#) (Coupe).
9. Connect the fuel lines.
10. Install the master cylinder. Refer to [BR-22, "Removal and Installation"](#).
11. Connect the clutch hose to the reservoir tank (if equipped).
12. Install the air cleaner assembly. Refer to [EM-25, "Removal and Installation"](#) (QR25DE), [EM-131, "Removal and Installation"](#) (VQ35DE).
13. Adjust the brake pedal height. Refer to [BR-44, "Brake Pedal"](#).
14. Tighten lock nut of input rod to the specified torque. Refer to [BR-24, "Exploded View"](#).
15. Refill new brake fluid and bleed air. Refer to [BR-16, "Bleeding Brake System"](#).

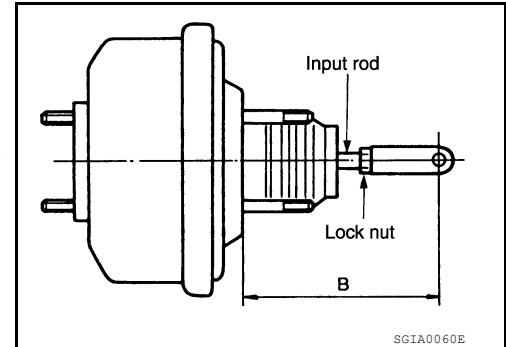

VACUUM LINES

< REMOVAL AND INSTALLATION >

VACUUM LINES

Exploded View

INFOID:000000006390876

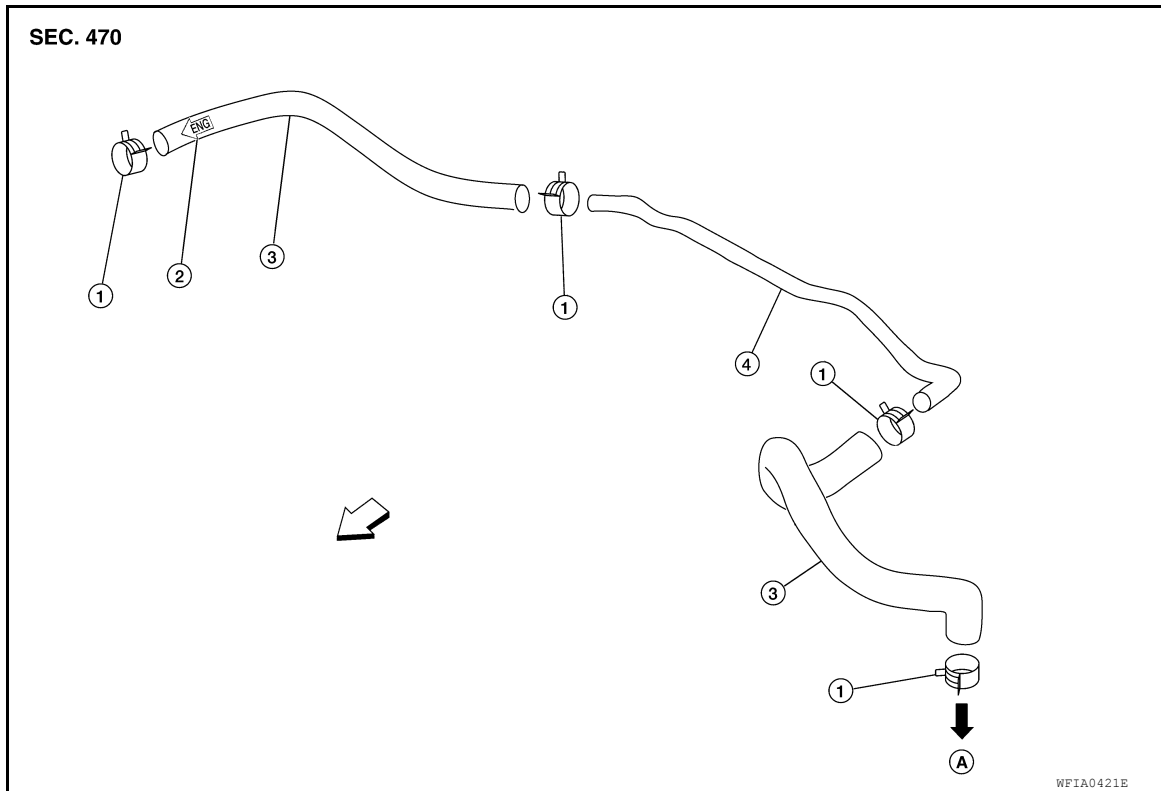

Removal and Installation

INFOID:000000006390877

REMOVAL

1. Disconnect the vacuum hose from the brake booster.
2. Disconnect the vacuum hose from the engine intake manifold.
3. Remove the vacuum hose.

INSTALLATION

Installation is in the reverse order of removal.

- Inspect the vacuum hose and one-way check valve before installation. Refer to [BR-27, "Inspection After Removal"](#).

CAUTION:

- Because the vacuum hose contains a one-way check valve, the hose must be installed in the correct position. Refer to the stamp on the hose to confirm the correct direction for installation. The brake booster will not operate normally if the hose is installed in the wrong direction.
- Do not use lubricating oil during assembly.

VACUUM LINES

< REMOVAL AND INSTALLATION >

- Insert the vacuum hose at least 24 mm (0.94 in) onto the brake booster fitting as shown.

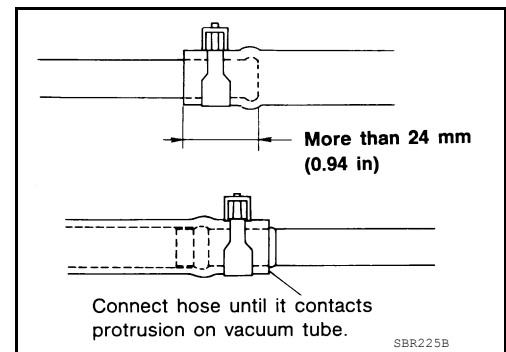

Inspection After Removal

INFOID:00000006390878

VISUAL

Check for correct assembly, damage and deterioration.

CHECK VALVE AIRTIGHTNESS

- Use a suitable tool (A) to check the one-way valve from each end of the hose.

When connected to the booster side (B) : Refer to [BR-45, "Check Valve"](#).

When connected to the engine side (C) : Refer to [BR-45, "Check Valve"](#).

- Replace the vacuum hose assembly if the vacuum hose or check valve are malfunctioning.

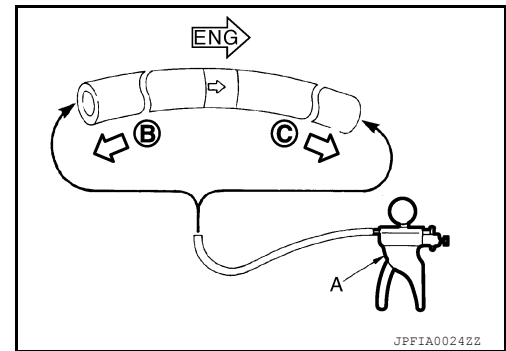

FRONT DISC BRAKE

< REMOVAL AND INSTALLATION >

FRONT DISC BRAKE

BRAKE PAD

BRAKE PAD : Exploded View

INFOID:000000006390879

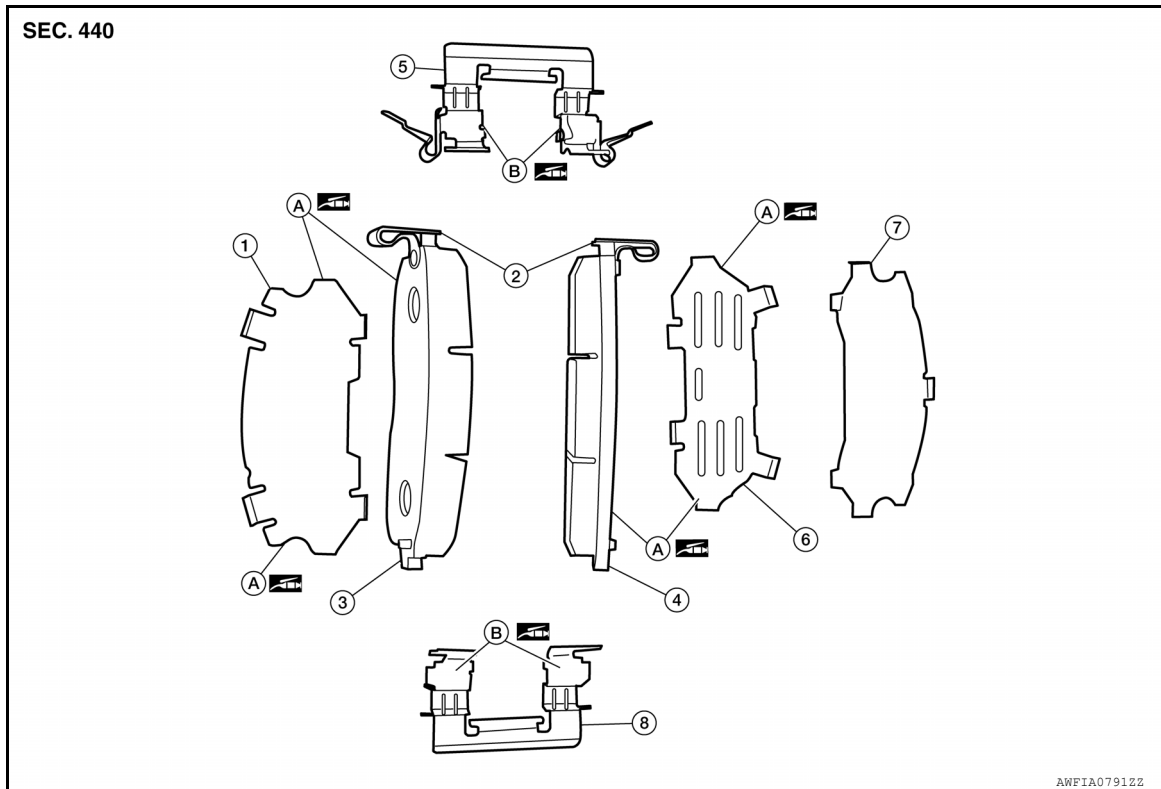

- | | | |
|----------------------------|-----------------------|----------------------------|
| 1. Inner multilayered shim | 2. Pad wear sensors | 3. Inner pad |
| 4. Outer pad | 5. Pad retainer upper | 6. Outer shim |
| 7. Outer shim cover | 8. Pad retainer lower | A. Molykote AS-880N grease |
| B. Molykote 7439 grease | | |

BRAKE PAD : Removal and Installation

INFOID:000000006390880

WARNING:

Clean dust on caliper and brake pad with a vacuum dust collector to minimize the hazard of air borne particles or other materials.

CAUTION:

- While removing caliper, do not depress brake pedal because piston will pop out.
- It is not necessary to remove bolts on torque member and brake hose except for disassembly or replacement of caliper assembly. In this case, hang caliper with a wire so as not to stretch brake hose.
- Do not damage piston boot.
- If any shim is subject to serious corrosion, replace it with a new one.
- Always replace shim and shim cover as a set when replacing brake pads.
- Keep rotor and pads free from brake fluid and grease.
- Burnish the brake pads and disc rotor mutually contacting surfaces, after refinishing or replacing rotors, after replacing pads, or if a soft pedal occurs at very low mileage. Refer to [BR-30, "BRAKE PAD : Brake Burnishing Procedure"](#).

REMOVAL

1. Remove the front wheel and tires. Refer to [WT-65, "Adjustment"](#).

FRONT DISC BRAKE

< REMOVAL AND INSTALLATION >

2. Remove lower sliding pin bolt.

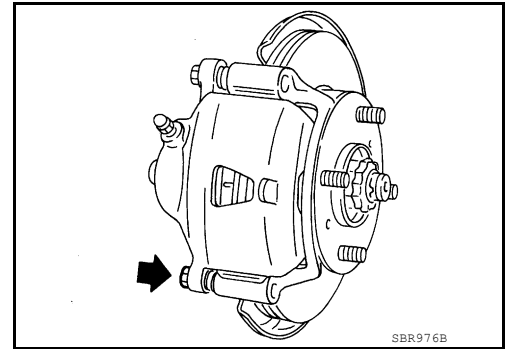

3. Hang caliper with a suitable wire, and remove pads, pad retainers, shims, and shim cover from torque member.

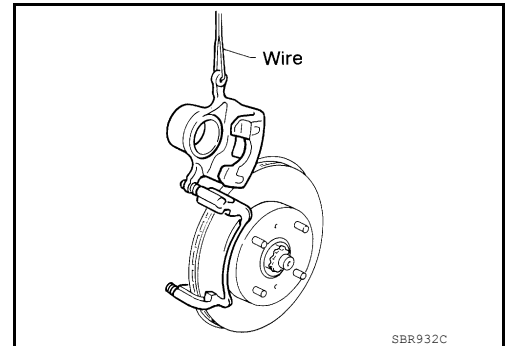

CAUTION:

When removing the pad retainer from the torque member, lift it in the direction indicated by the arrow as shown so that it does not deform.

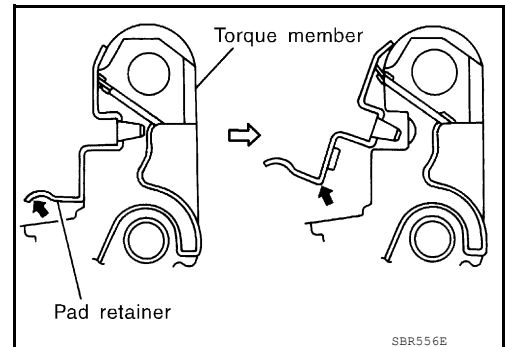

INSTALLATION

1. Apply Molykote AS-880N grease or equivalent between the outer shim cover and shim; and the inner multilayered shim and inner pad. Install outer shim, outer shim cover to outer pad, and inner multilayered shim to inner pad.
2. Apply Molykote 7439 grease or equivalent between pad retainers and pad ends. Install pad retainers and pads on torque member.

CAUTION:

- Securely assemble pad retainers so that they are not being lifted up from torque member.
- Both inner and outer pads have a pad return system on the pad retainer. Install pad return lever securely to pad wear sensor.

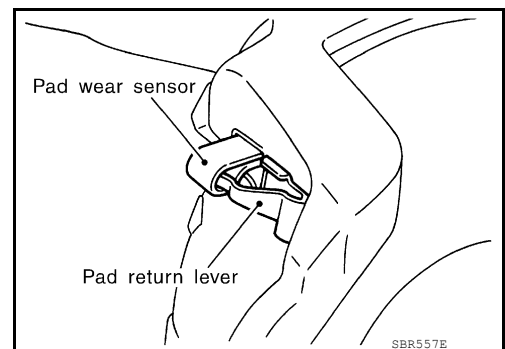

3. Install caliper over assembled pads on to the torque member.

CAUTION:

When replacing a pad with new one, check brake fluid level in the reservoir tank because brake fluid returns to master cylinder reservoir tank when pressing in the piston.

NOTE:

Use a disc brake piston tool (commercial service tool) to easily press in the piston.

A
B
C
D
E
BR
G
H
I
J
K
L
M
N
O
P

FRONT DISC BRAKE

< REMOVAL AND INSTALLATION >

4. Install lower sliding pin bolt, and tighten it to the specified torque. Refer to [BR-30, "BRAKE CALIPER ASSEMBLY : Exploded View"](#).
5. Check front disc brake for drag.
6. Install the front wheel and tires. Refer to [WT-65, "Adjustment"](#).

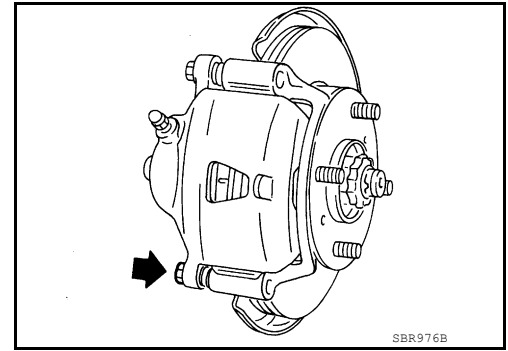

BRAKE PAD : Brake Burnishing Procedure

INFOID:000000006390881

Burnish contact surfaces between disc rotors and pads according to following procedure after refinishing or replacing rotors, after replacing pads, or if a soft pedal occurs at very low mileage.

CAUTION:

- Be careful of vehicle speed because the brake does not operate easily until pad and disc rotor are securely fitted.
 - Only perform this procedure under safe road and traffic conditions. Use extreme caution.
1. Drive vehicle on straight, flat road.
 2. Depress brake pedal with the power to stop vehicle within 3 to 5 seconds until the vehicle stops.
 3. Drive without depressing brake for a few minutes to cool the brake.
 4. Repeat steps 1 to 3 until pad and disc rotor are securely fitted.

BRAKE CALIPER ASSEMBLY

BRAKE CALIPER ASSEMBLY : Exploded View

INFOID:000000006390882

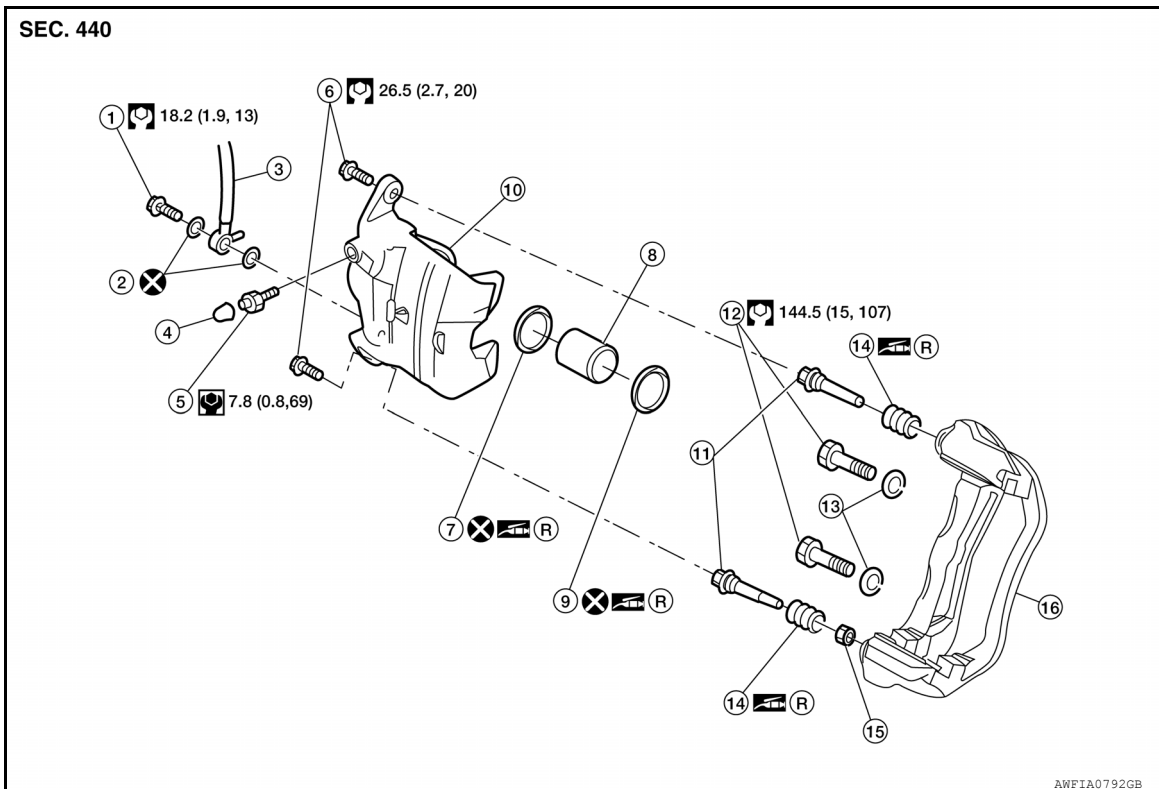

- | | | |
|----------------|--------------------------|------------------------|
| 1. Union bolt | 2. Copper sealing washer | 3. Brake hose |
| 4. Cap | 5. Bleed valve | 6. Sliding pin bolt |
| 7. Piston seal | 8. Piston | 9. Piston boot |
| 10. Caliper | 11. Sliding pin | 12. Torque member bolt |

FRONT DISC BRAKE

< REMOVAL AND INSTALLATION >

- | | | |
|-------------------|----------------------|-------------|
| 13. Washer | 14. Sliding pin boot | 15. Bushing |
| 16. Torque member | R. Rubber grease | |

BRAKE CALIPER ASSEMBLY : Removal and Installation

INFOID:000000006390883

WARNING:

Clean dust on caliper and brake pad with a vacuum dust collector to minimize the hazard of air borne particles or other materials.

CAUTION:

- While removing caliper, do not depress the brake pedal because the piston will pop out.
- Do not damage piston boot.
- Keep disc rotor free from brake fluid.
- Refill the brake reservoir with new brake fluid "DOT 3".
- Never reuse drained brake fluid.

NOTE:

When removing components such as hoses, tubes/lines, etc., cap or plug openings to prevent fluid from spilling.

REMOVAL

1. Remove front wheel and tires. Refer to [WT-65. "Adjustment"](#).
2. Remove brake reservoir cap.
3. Remove union bolt (A) and disconnect brake hose from caliper assembly. Discard the copper sealing washers.
 - Protrusions (B)

CAUTION:

Do not reuse copper sealing washers.

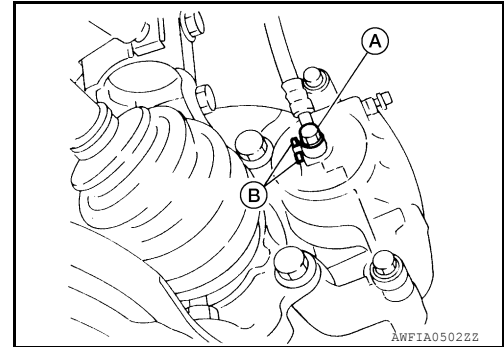

4. Remove torque member bolts, and remove brake caliper assembly.

CAUTION:

Do not drop brake pad.

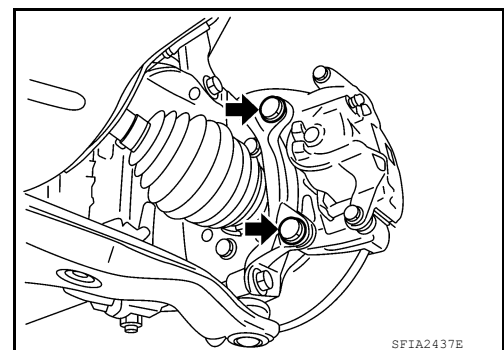

5. Remove disc rotor. If reusing the disc rotor apply matching marks as shown.

CAUTION:

Put matching marks on wheel hub assembly and disc rotor, if it is necessary to remove disc rotor.

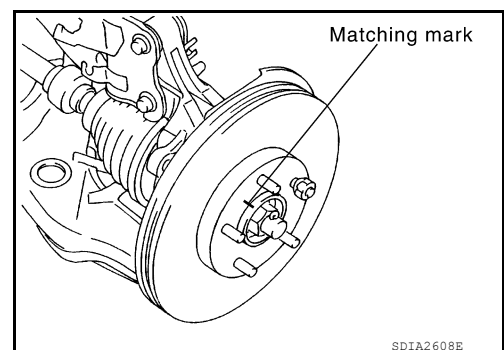

INSTALLATION

A
B
C
D
E
BR
G
H
I
J
K
L
M
N
O
P

FRONT DISC BRAKE

< REMOVAL AND INSTALLATION >

1. Install disc rotor, align the matching marks if installing the original disc rotor as shown.

CAUTION:

Align the marks on disc rotor and wheel hub at the time of installation when reusing disc rotor.

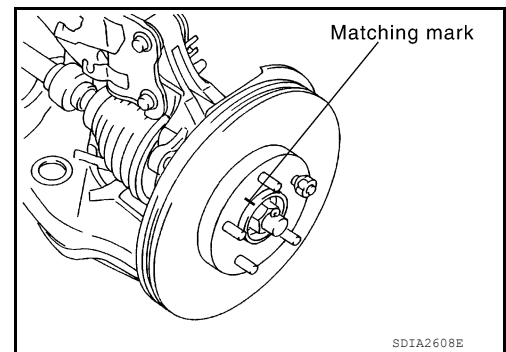

2. Install brake caliper assembly to vehicle, and tighten torque member bolts to the specified torque. Refer to [BR-30, "BRAKE CALIPER ASSEMBLY : Exploded View"](#).

CAUTION:

Do not allow oil or any moisture on all contact surfaces between steering knuckle and caliper assembly, bolts, and washer.

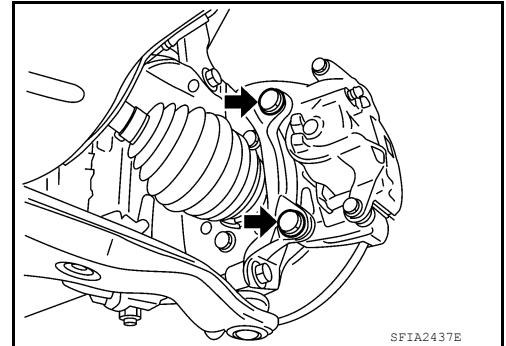

3. Install brake hose to brake caliper assembly with new copper sealing washers. Align the brake hose tab between the protrusions (B) on the caliper assembly as shown. Tighten union bolt (A) to the specified torque. Refer to [BR-18, "FRONT BRAKE : Removal and Installation"](#).

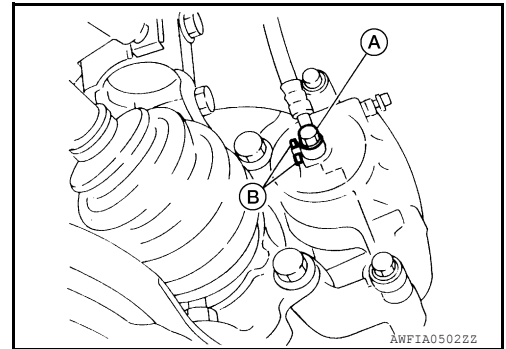

CAUTION:

Do not reuse copper sealing washers (1).

- Union bolt (A)

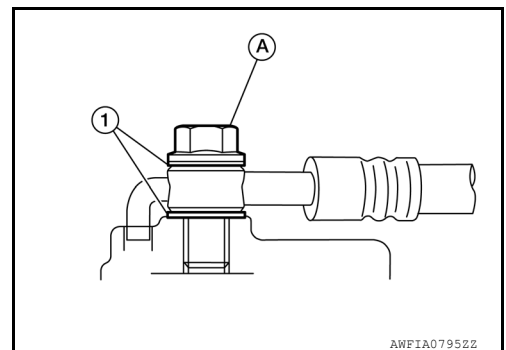

4. Refill with new brake fluid and bleed air from the brake hydraulic system. Refer to [BR-16, "Bleeding Brake System"](#).
5. Check front disc brakes for drag.
6. Install front wheel and tires. Refer to [WT-65, "Adjustment"](#).

REAR DISC BRAKE

< REMOVAL AND INSTALLATION >

REAR DISC BRAKE

BRAKE PAD

BRAKE PAD : Exploded View

INFOID:000000006390884

SEC. 441

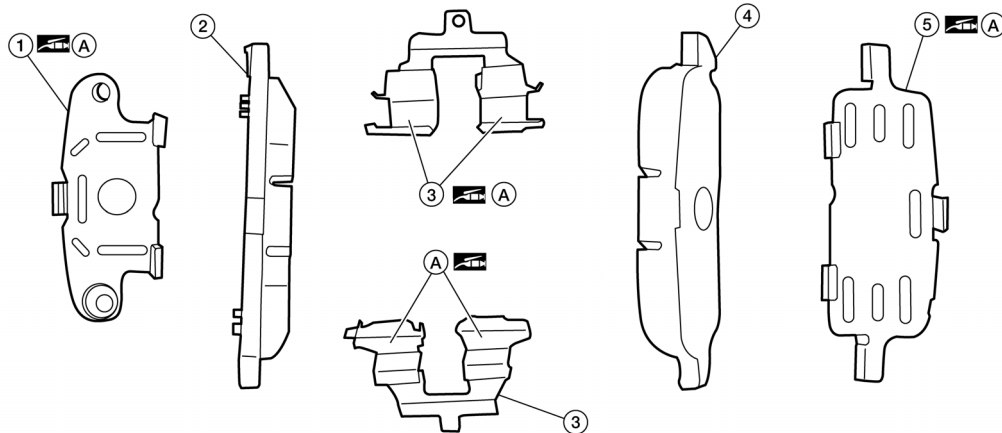

AWFIA0761GB

- | | | |
|----------------------------|----------------------------|----------------------------|
| 1. Inner multilayered shim | 2. Inner pad | 3. Pad retainer |
| 4. Outer pad | 5. Outer multilayered shim | A. Molykote AS-880N grease |

BRAKE PAD : Removal and Installation

INFOID:000000006390885

WARNING:

Clean dust on caliper and brake pad with a vacuum dust collector to minimize the hazard of air borne particles or other materials.

CAUTION:

- While removing caliper, do not depress brake pedal because piston will pop out.
- It is not necessary to remove bolts on torque member and brake hose except for disassembly or replacement of caliper assembly. In this case, hang caliper with a wire so as not to stretch brake hose.
- Do not damage piston boot.
- If any shim is subject to serious corrosion, replace it with a new one.
- Always replace shim and shim covers as a set when replacing brake pads.
- Keep rotor and pads free from brake fluid and grease.
- Burnish the brake pads and disc rotor mutually contacting surfaces after refinishing or replacing rotors, after replacing pads, or if a soft pedal occurs at very low mileage. Refer to [BR-30, "BRAKE PAD : Brake Burnishing Procedure"](#).

REMOVAL

1. Remove rear wheel and tires. Refer to [WT-65, "Adjustment"](#).
2. Remove upper sliding pin bolt (A) and swing caliper out supporting it with a suitable wire.

CAUTION:

Do not twist or stretch the brake hose.

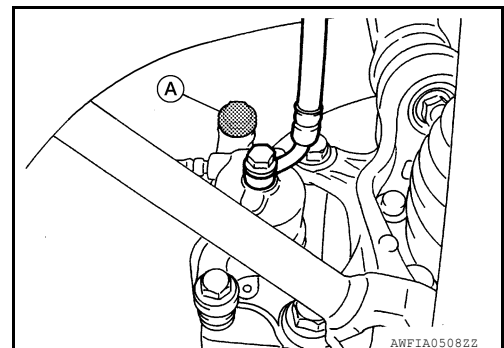

AWFIA05082Z

REAR DISC BRAKE

< REMOVAL AND INSTALLATION >

3. Remove pads, pad retainers and multilayered shims from torque member.

CAUTION:

When removing the pad retainer from the torque member, lift it in the direction indicated by the arrow as shown so that it does not deform.

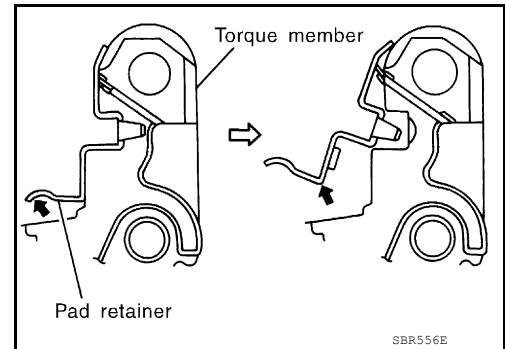

INSTALLATION

1. Apply Molykote AS-880N grease or equivalent to the caliper fingers, between multilayered shims and brake pads. Install inner multilayered shim to inner pad, and outer multilayered shim to outer pad.
2. Apply Molykote AS-880N grease (A) to the pad retainer as shown.

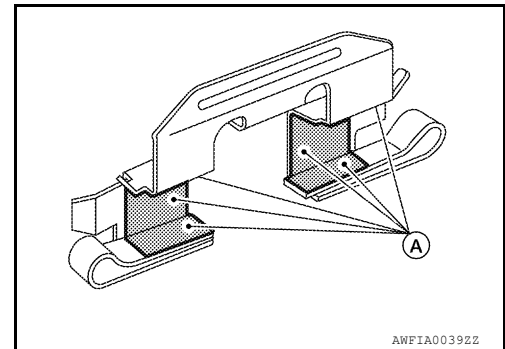

3. Attach pad retainers to torque member, then install brake pads and multilayered shim assemblies.

CAUTION:

When attaching pad retainer, attach it firmly so that it is flush with torque member as shown.

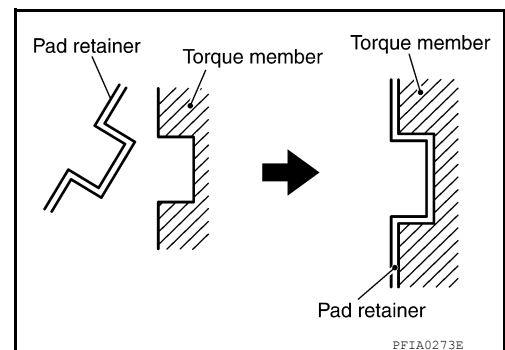

4. Press in piston until pads can be installed, and then install caliper to torque member.

CAUTION:

In the case of replacing a pad with new one, check a brake fluid level in the reservoir tank because brake fluid returns to master cylinder reservoir tank when pressing piston in.

NOTE:

Use a disc brake piston tool (commercial service tool) to easily press piston.

5. Install upper sliding pin bolt (A) and tighten to the specified torque. Refer to [BR-35. "BRAKE CALIPER ASSEMBLY : Exploded View"](#).
6. Check rear disc brake for drag.
7. Install rear wheel and tires. Refer to [WT-65. "Adjustment"](#).

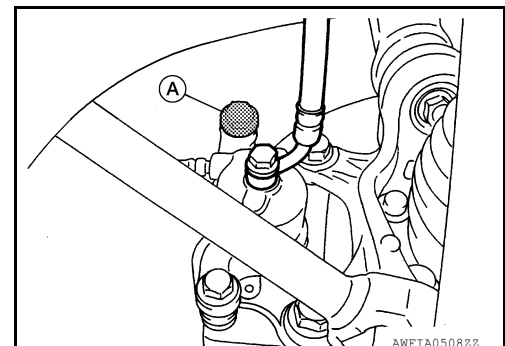

BRAKE CALIPER ASSEMBLY

REAR DISC BRAKE

< REMOVAL AND INSTALLATION >

BRAKE CALIPER ASSEMBLY : Exploded View

INFOID:000000006390886

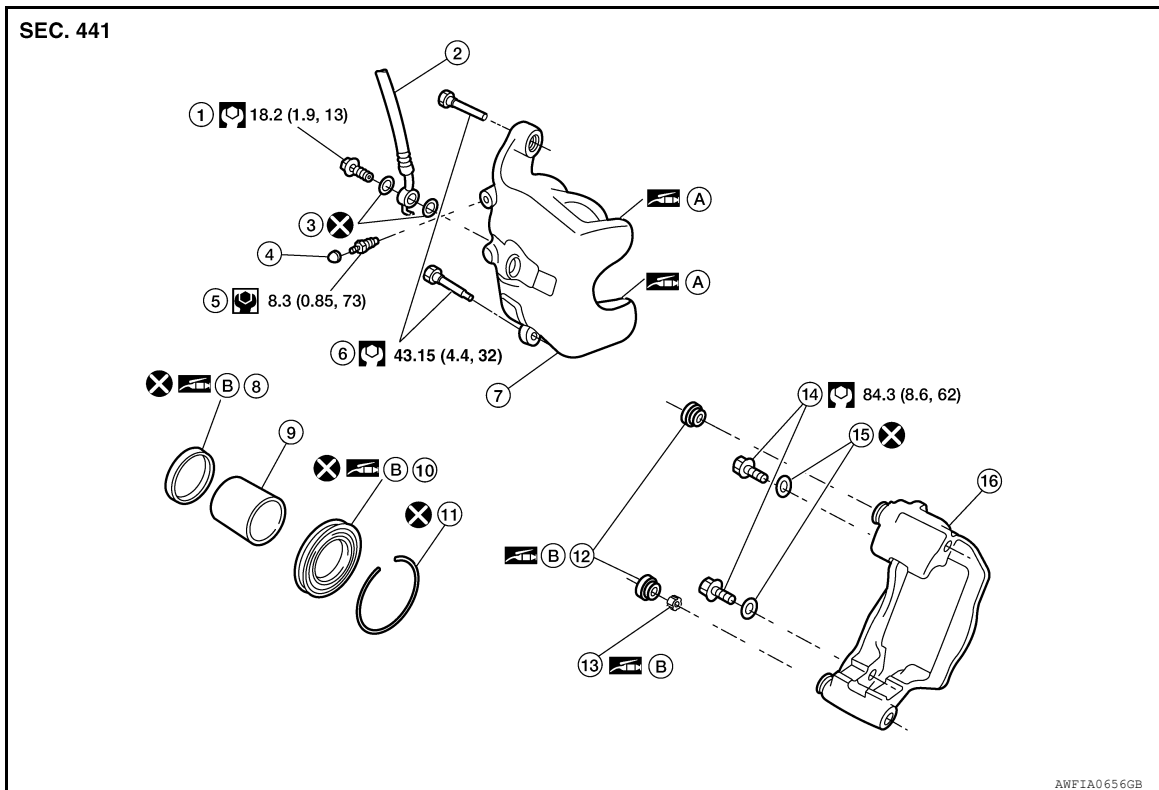

- | | | |
|-------------------|--|--------------------------|
| 1. Union bolt | 2. Brake hose | 3. Copper sealing washer |
| 4. Cap | 5. Bleed valve | 6. Sliding pin bolt |
| 7. Caliper | 8. Piston seal | 9. Piston |
| 10. Piston boot | 11. Retaining ring | 12. Sliding pin boot |
| 13. Bushing | 14. Torque member bolt | 15. Washer |
| 16. Torque member | A. PBC (Poly Butyl Cuprysil) grease or silicone-based grease | B. Rubber grease |

BRAKE CALIPER ASSEMBLY : Removal and Installation

INFOID:000000006390887

WARNING:

Clean dust on caliper and brake pad with a vacuum dust collector to minimize the hazard of air borne particles or other materials.

CAUTION:

- While removing caliper, do not depress brake pedal because the piston will pop out.
- Do not damage piston boot.
- Keep disc rotor free from brake fluid.
- Refill the brake reservoir with new brake fluid "DOT 3".
- Never reuse drained brake fluid.

NOTE:

When removing components such as hoses, tubes/lines, etc., cap or plug openings to prevent fluid from spilling.

REMOVAL

1. Remove rear wheel and tires. Refer to [WT-65, "Adjustment"](#).
2. Fasten disc rotor using a wheel nut.
3. Remove brake reservoir cap.

REAR DISC BRAKE

< REMOVAL AND INSTALLATION >

4. Remove union bolt (A) and then disconnect brake hose from caliper. Discard the copper sealing washers.

CAUTION:

Do not reuse copper sealing washers.

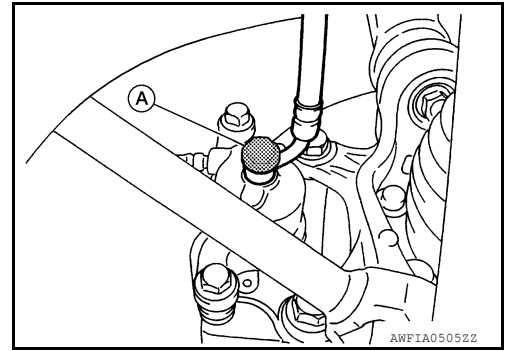

5. Remove the two torque member bolts (A), and then remove the torque member, caliper and pads as an assembly.

CAUTION:

Do not drop the brake pad and multilayered shim assemblies.

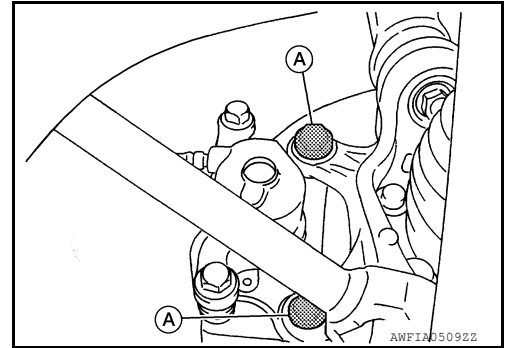

6. Remove the two sliding pin bolts and separate the caliper from the torque member. Remove the brake pad and multilayered shim assemblies from the torque member.

7. Remove the disc rotor.

CAUTION:

Put matching marks on wheel hub assembly and disc rotor, if it necessary to reuse the disc rotor.

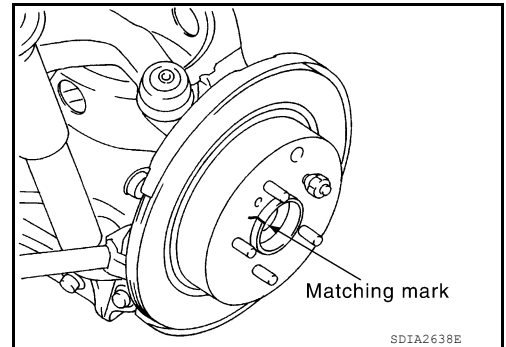

INSTALLATION

1. Install the disc rotor.

CAUTION:

Alignment marks of disc rotor and wheel hub put at the time of removal when reusing disc rotor.

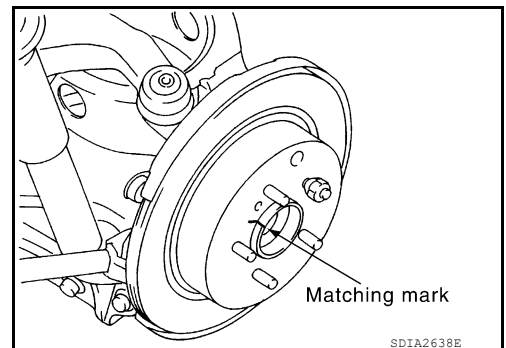

2. Install the brake pad and multilayered shim assemblies on the torque member. Refer to [BR-33. "BRAKE PAD : Exploded View"](#).
3. Install the caliper and pad assembly on the torque member, then tighten the two sliding pin bolts to the specified torque. Refer to [BR-35. "BRAKE CALIPER ASSEMBLY : Exploded View"](#).

REAR DISC BRAKE

< REMOVAL AND INSTALLATION >

4. Install the torque member, pads and brake caliper assembly, and tighten the torque member bolts (A) to the specified torque. Refer to [BR-35. "BRAKE CALIPER ASSEMBLY : Exploded View"](#).

CAUTION:

Before installing wipe off all oil and moisture on all mating surfaces of rear axle and torque member, threads, bolts and washers.

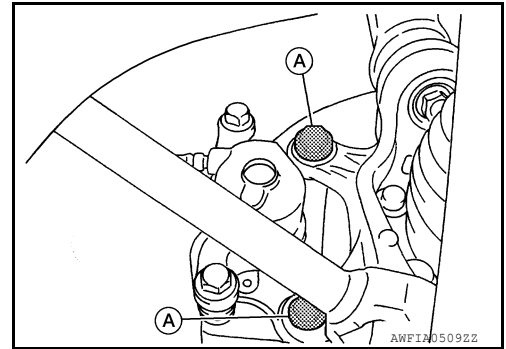

5. Align the L-shaped pin on the brake hose in the hole in the caliper, then install the brake hose with new copper sealing washers (1) and tighten the union bolt (A) to the specified torque. Refer to [BR-20. "REAR BRAKE : Removal and Installation"](#).

CAUTION:

Do not reuse copper sealing washers.

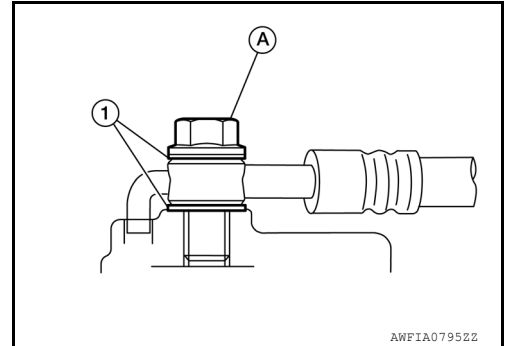

6. Refill with new brake fluid and bleed air. Refer to [BR-16. "Bleeding Brake System"](#).
7. Check rear disc brake for drag.
8. Install rear wheel and tires. Refer to [WT-65. "Adjustment"](#).

A
B
C
D
E
BR
G
H
I
J
K
L
M
N
O
P

FRONT DISC BRAKE

< UNIT DISASSEMBLY AND ASSEMBLY >

UNIT DISASSEMBLY AND ASSEMBLY

FRONT DISC BRAKE

BRAKE CALIPER ASSEMBLY

BRAKE CALIPER ASSEMBLY : Exploded View

INFOID:000000006390888

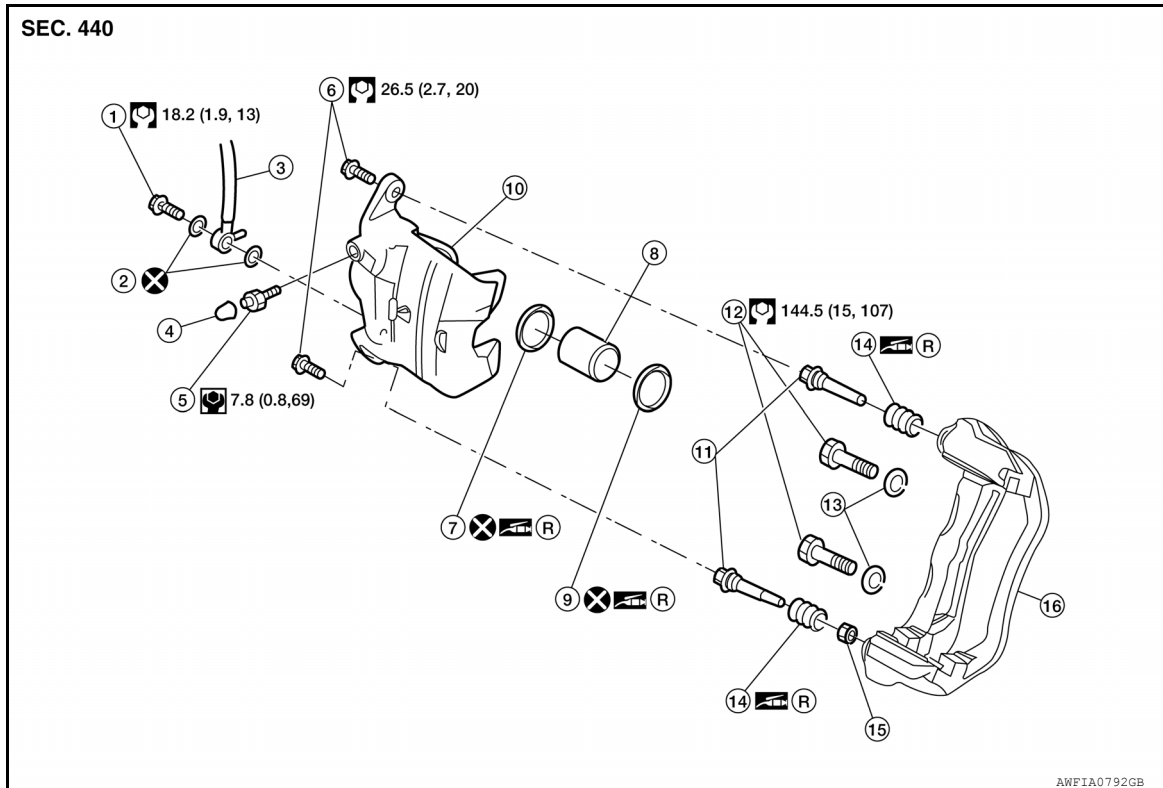

- | | | |
|-------------------|--------------------------|------------------------|
| 1. Union bolt | 2. Copper sealing washer | 3. Brake hose |
| 4. Cap | 5. Bleed valve | 6. Sliding pin bolt |
| 7. Piston seal | 8. Piston | 9. Piston boot |
| 10. Caliper | 11. Sliding pin | 12. Torque member bolt |
| 13. Washer | 14. Sliding pin boot | 15. Bushing |
| 16. Torque member | R. Rubber grease | |

BRAKE CALIPER ASSEMBLY : Disassembly

INFOID:000000006390889

DISASSEMBLY

NOTE:

Do not remove the torque member, pads, multilayered shim, shim, shim cover, and pad retainers when disassembling and assembling the caliper.

1. Place a wooden block in the caliper as shown, and blow air into the union bolt hole to remove the piston and piston boot.

WARNING:

Do not get fingers caught between the piston and wooden block.

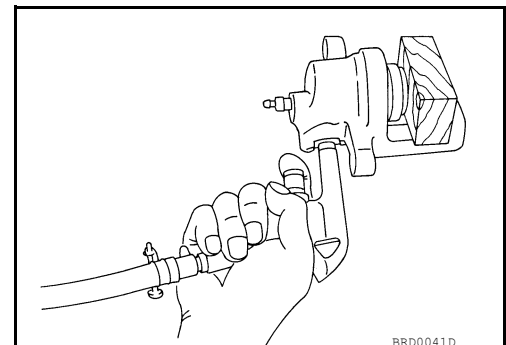

FRONT DISC BRAKE

< UNIT DISASSEMBLY AND ASSEMBLY >

- Remove the piston seal from the caliper using a suitable tool.
Discard the piston seal.

CAUTION:

- Be careful not to damage a cylinder inner wall.
- Do not reuse the piston seal.

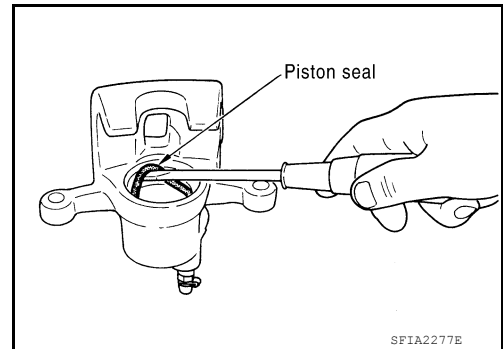

BRAKE CALIPER ASSEMBLY : Inspection After Disassembly

INFOID:000000006390890

CALIPER

Check the inner wall of caliper for corrosion, wear, and damage. Replace as necessary.

CAUTION:

Clean the caliper using new brake fluid. Never use mineral oils such as gasoline or kerosene.

TORQUE MEMBER

Check torque member for wear, cracks, and damage. Replace as necessary.

PISTON

Check the piston surface for corrosion, wear, and damage. Replace as necessary.

CAUTION:

The piston sliding surface is plated. Do not polish with sandpaper.

SLIDING PIN, SLIDING PIN BOOT, SLIDING PIN BOLT

Check the sliding pin, sliding pin bolt, and sliding pin boot for wear, damage, and cracks. Replace as necessary.

BRAKE CALIPER ASSEMBLY : Assembly

INFOID:000000006390891

ASSEMBLY

CAUTION:

Use NISSAN Rubber Grease during assembly.

- Apply rubber grease to new piston seal, and install on caliper.

CAUTION:

Do not reuse piston seal.

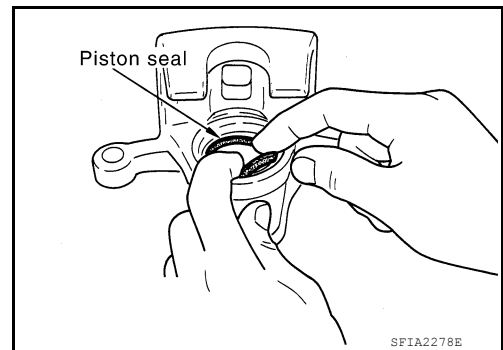

- Apply rubber grease to new piston boot. Cover the piston end with new piston boot, and then install cylinder side lip on new piston boot securely into a groove on caliper.

CAUTION:

Do not reuse piston boot.

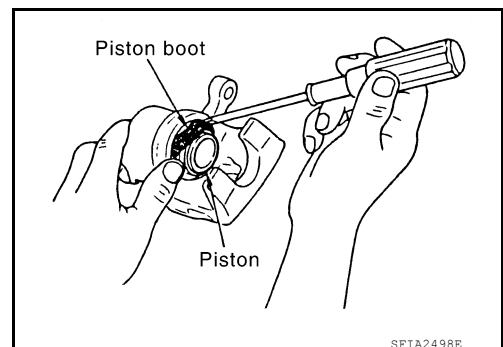

A
B
C
D
E
BR
G
H
I
J
K
L
M
N
O
P

FRONT DISC BRAKE

< UNIT DISASSEMBLY AND ASSEMBLY >

3. Push piston into caliper by hand and push piston boot piston-side lip into the piston groove.

CAUTION:

Press the piston evenly and vary the pressing point to prevent cylinder inner wall from being rubbed.

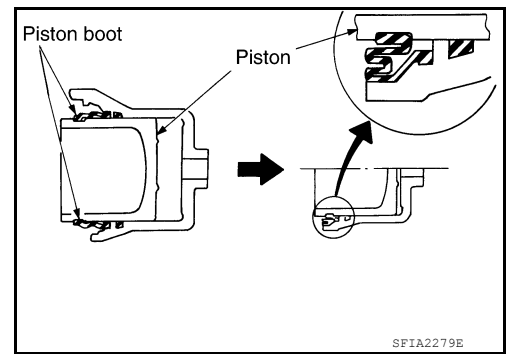

REAR DISC BRAKE

< UNIT DISASSEMBLY AND ASSEMBLY >

REAR DISC BRAKE BRAKE CALIPER ASSEMBLY

BRAKE CALIPER ASSEMBLY : Exploded View

INFOID:000000006390892

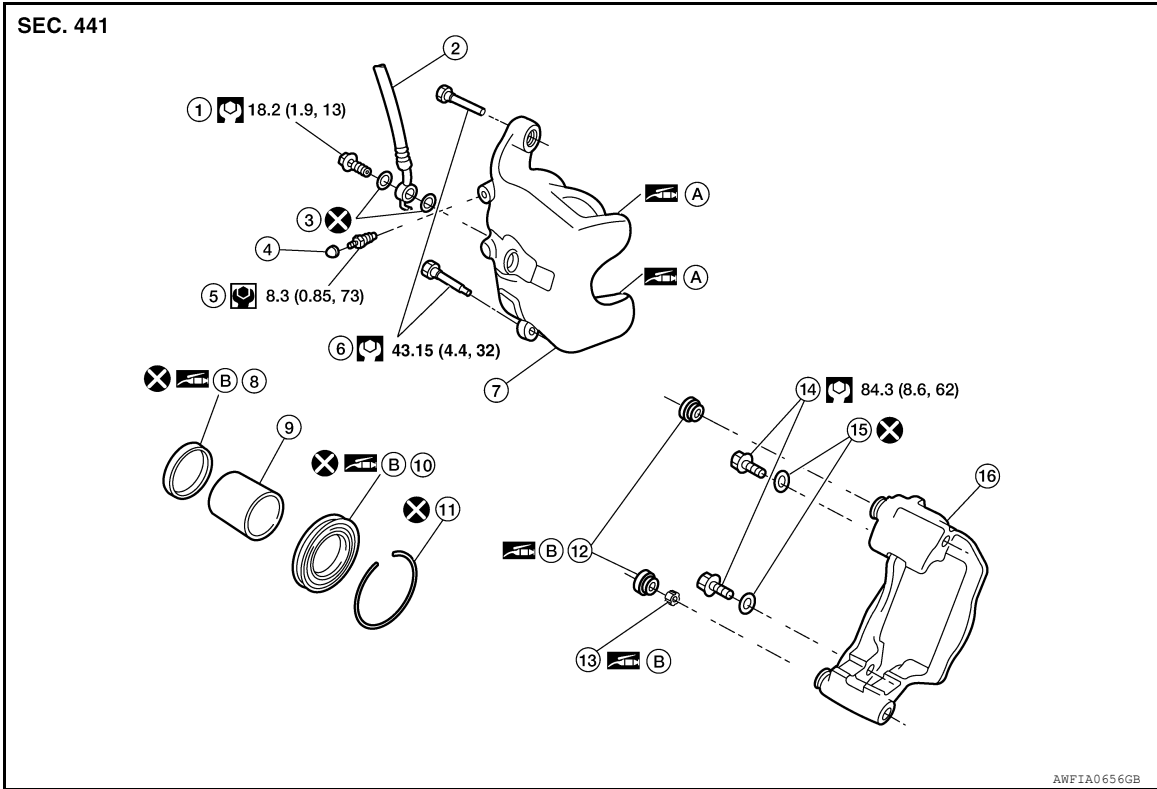

- | | | |
|-------------------|--|--------------------------|
| 1. Union bolt | 2. Brake hose | 3. Copper sealing washer |
| 4. Cap | 5. Bleed valve | 6. Sliding pin bolt |
| 7. Caliper | 8. Piston seal | 9. Piston |
| 10. Piston boot | 11. Retaining ring | 12. Sliding pin boot |
| 13. Bushing | 14. Torque member bolt | 15. Washer |
| 16. Torque member | A. PBC (Poly Butyl Cuprysil) grease or silicone-based grease | B. Rubber grease |

BRAKE CALIPER ASSEMBLY : Disassembly

INFOID:000000006390893

DISASSEMBLY

1. Remove the retaining ring from caliper using a suitable tool as shown. Discard the retaining ring

CAUTION:

Do not reuse retaining ring.

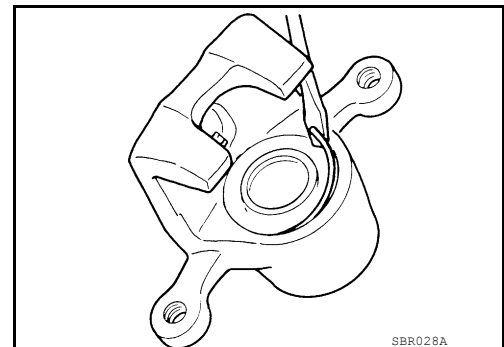

REAR DISC BRAKE

< UNIT DISASSEMBLY AND ASSEMBLY >

2. Place a wooden block in the caliper as shown, and blow air into the union bolt hole to the remove piston and piston boot.

WARNING:

Do not get fingers caught between the piston and wooden block.

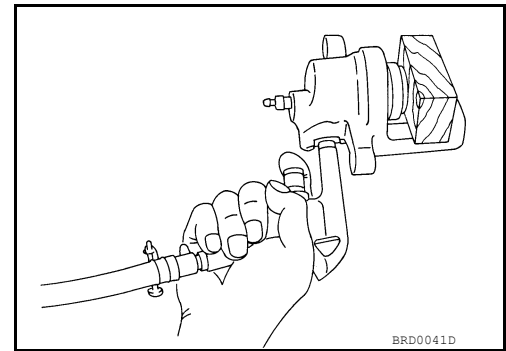

3. Remove the piston seal from the caliper using a suitable tool. Discard the piston seal.

CAUTION:

- Be careful not to damage a cylinder inner wall.
- Do not reuse the piston seal.

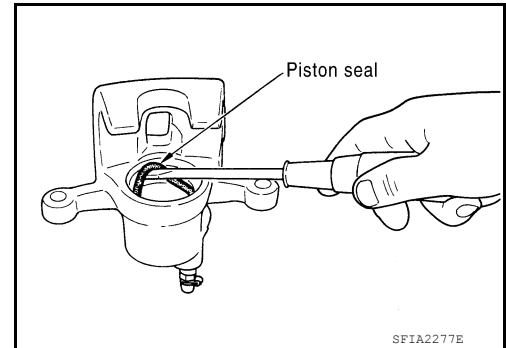

BRAKE CALIPER ASSEMBLY : Inspection After Disassembly

INFOID:000000006390894

CALIPER

Check the inner wall of the cylinder for corrosion, wear, and damage. Replace as necessary.

CAUTION:

Clean the caliper using new brake fluid. Never use mineral oils such as gasoline or kerosene.

TORQUE MEMBER

Check the torque member for wear, cracks, and damage. Replace as necessary.

PISTON

Check the piston surface for corrosion, wear, and damage. Replace as necessary.

CAUTION:

The piston sliding surface is plated. Do not polish with sandpaper.

SLIDING PIN BOLT, SLIDING PIN BOOT

Check the sliding pin bolt and sliding pin boot for wear, damage, and cracks. Replace as necessary.

BRAKE CALIPER ASSEMBLY : Assembly

INFOID:000000006390895

ASSEMBLY

CAUTION:

Use NISSAN Rubber Grease during assembly.

1. Apply rubber grease to new piston seal, and install them on caliper.

CAUTION:

Do not reuse piston seal.

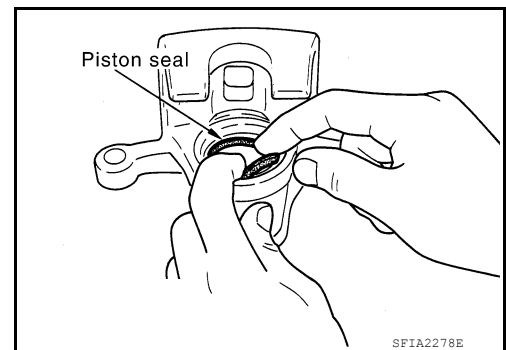

REAR DISC BRAKE

< UNIT DISASSEMBLY AND ASSEMBLY >

2. Apply rubber grease to new piston boot. Cover the piston end with the new piston boot, and then install cylinder side lip on the new piston boot securely into the groove on caliper.

CAUTION:

Do not reuse piston boot.

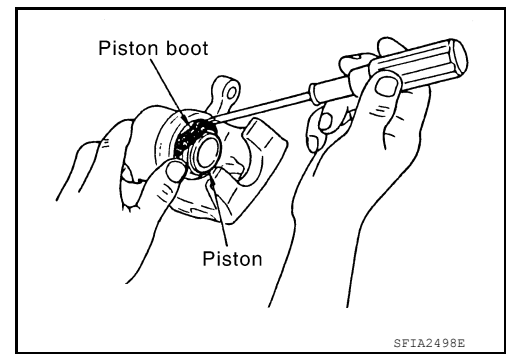

3. Push piston into caliper by hand and push piston boot piston side lip into the piston groove.

CAUTION:

Press the piston evenly and vary the pressing point to prevent cylinder inner wall from being rubbed.

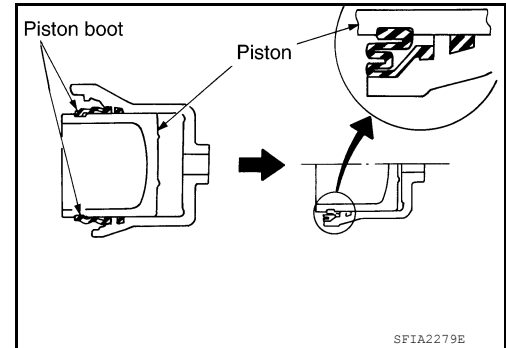

4. Secure piston boot with new retaining ring.

CAUTION:

- **Make sure that boot is securely engaged in the groove on caliper.**
- **Do not reuse retainer ring.**

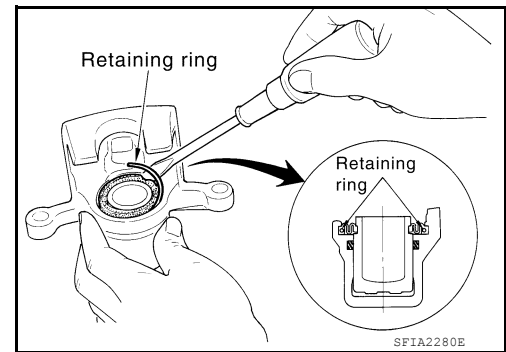

A
B
C
D
E
BR
G
H
I
J
K
L
M
N
O
P

SERVICE DATA AND SPECIFICATIONS (SDS)

< SERVICE DATA AND SPECIFICATIONS (SDS)

SERVICE DATA AND SPECIFICATIONS (SDS)

SERVICE DATA AND SPECIFICATIONS (SDS)

General Specifications

INFOID:000000006390896

Unit: mm (in)

Front brake	Brake model	CLZ25VD
	Cylinder bore diameter	57.2 (2.252)
	Pad length × width × thickness	126 × 50 × 11 (4.961 × 1.969 × 0.433)
	Rotor outer diameter × thickness	296 × 26 (11.654 × 1.024)
Rear brake	Brake model	AD9VA
	Cylinder bore diameter	34.93 (1.375)
	Pad length × width × thickness	83 × 33 × 8.5 (3.268 × 1.299 × 0.335)
	Rotor outer diameter × thickness	292 × 9 (11.50 × 0.354)
Master cylinder	Cylinder bore diameter	19.05 (0.750)
Control valve	Valve model	Electric brake force distribution
Brake booster	Booster model	Bosch
	Diaphragm diameter	280 (11)
Recommended brake fluid		DOT 3

Brake Pedal

INFOID:000000006390897

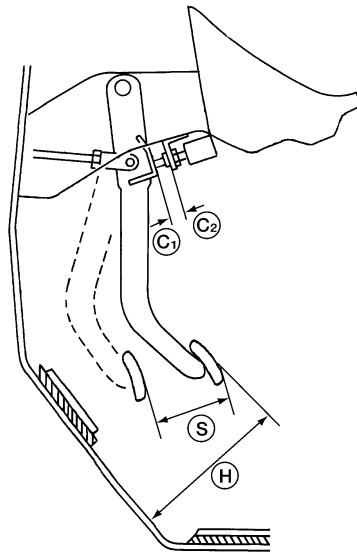

AWPIA05572Z

Brake pedal height (H) (from dash lower panel top surface)	CVT	190.7 - 202.7 mm (7.51 - 7.98 in)
	M/T	181.3 - 193.3 mm (7.14 - 7.61 in)
Brake pedal full stroke (S)	CVT	130 mm (5.12 in)
	M/T	130 mm (5.12 in)
Clearance between stopper bracket (C1) and threaded end of the stop lamp switch and ASCD cancel switch (C2)		0.74 - 1.96 mm (0.0291 - 0.0772 in)

SERVICE DATA AND SPECIFICATIONS (SDS)

< SERVICE DATA AND SPECIFICATIONS (SDS)

Check Valve

INFOID:000000006390898

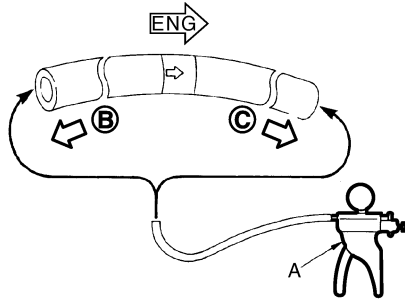

JPF1A0024ZZ

When suitable tool (A) is connected to the booster side (B)	Vacuum should not decrease more than 1.3 kPa (10 mmHg, 0.39 inHg) for 15 seconds under a vacuum of -26.6 ± 1.3 kPa (-200 ± 1.0 mmHg, -7.87 ± 0.04 inHg).
When suitable tool (A) is connected to the engine side (C)	Vacuum should not exist.

Brake Booster

INFOID:000000006390899

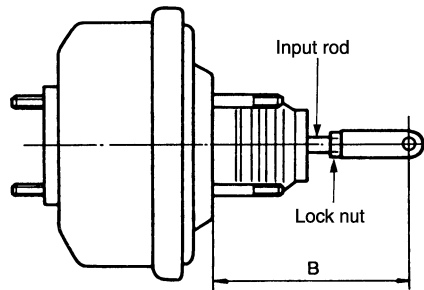

SG1A0060E

Input rod installation standard dimension (B)	125 ± 0.5 mm (4.92 \pm 0.02 in)
---	---------------------------------------

Front Disc Brake

INFOID:000000006390900

Brake model	CLZ25VD	
Brake pad	Standard thickness (new)	11.0 mm (0.433 in)
	Wear limit thickness	2.0 mm (0.079 in)
Disc rotor	Standard thickness (new)	26.0 mm (1.024 in)
	Wear limit thickness	24.0 mm (0.945 in)
	Thickness variation (measured at 8 positions)	0.015 mm (0.0006 in)
	Maximum runout (with it attached to the vehicle)	0.040 mm (0.0016 in)

Rear Disc Brake

INFOID:000000006390901

Brake model	AD9VA	
Brake pad	Standard thickness (new)	8.5 mm (0.335 in)
	Wear limit thickness	1.0 mm (0.039 in)

SERVICE DATA AND SPECIFICATIONS (SDS)

< SERVICE DATA AND SPECIFICATIONS (SDS)

Brake model		AD9VA
Disc rotor	Standard thickness (new)	9.0 mm (0.354 in)
	Wear limit thickness	8.0 mm (0.315 in)
	Thickness variation (measured at 8 positions)	0.015 mm (0.0006 in)
	Maximum runout (with it attached to the vehicle)	0.05 mm (0.0020 in)