

SECTION **FSU**  
FRONT SUSPENSION

A  
B  
C  
D  
E  
F  
G  
H  
I  
J  
K  
L  
M  
N  
O  
P

FSU

CONTENTS

<b>PRECAUTION</b> .....	2	Removal and Installation .....	9	F
<b>PRECAUTIONS</b> .....	2	Disposal .....	9	
Precaution for Supplemental Restraint System (SRS) "AIR BAG" and "SEAT BELT PRE-TENSIONER" .....	2	<b>TRANSVERSE LINK</b> .....	11	G
Precaution Necessary for Steering Wheel Rotation After Battery Disconnect .....	2	Removal and Installation .....	11	
General Precautions .....	3	<b>FRONT STABILIZER</b> .....	12	H
<b>SYMPTOM DIAGNOSIS</b> .....	4	Removal and Installation .....	12	
<b>NOISE, VIBRATION AND HARSHNESS (NVH) TROUBLESHOOTING</b> .....	4	<b>UNIT REMOVAL AND INSTALLATION</b> .....	13	I
NVH Troubleshooting Chart .....	4	<b>FRONT SUSPENSION ASSEMBLY</b> .....	13	J
<b>PREPARATION</b> .....	5	Exploded View .....	13	
<b>PREPARATION</b> .....	5	Removal and Installation .....	14	
Special Service Tool .....	5	<b>UNIT DISASSEMBLY AND ASSEMBLY</b> ...	15	K
Commercial Service Tool .....	6	<b>FRONT COIL SPRING AND STRUT</b> .....	15	
<b>PERIODIC MAINTENANCE</b> .....	7	Disassembly and Assembly .....	15	
<b>FRONT SUSPENSION ASSEMBLY</b> .....	7	Inspection .....	17	L
Inspection and Adjustment .....	7	<b>SERVICE DATA AND SPECIFICATIONS (SDS)</b> .....	18	M
<b>REMOVAL AND INSTALLATION</b> .....	9	General Specification (Front) .....	18	
<b>FRONT COIL SPRING AND STRUT</b> .....	9	Wheel Alignment (Unladen *1) .....	18	N
		Ball Joint .....	18	
		Wheelarch Height (Unladen*1) .....	19	O
				P

# PRECAUTIONS

< PRECAUTION >

## PRECAUTION

### PRECAUTIONS

#### Precaution for Supplemental Restraint System (SRS) "AIR BAG" and "SEAT BELT PRE-TENSIONER"

INFOID:000000006392660

The Supplemental Restraint System such as "AIR BAG" and "SEAT BELT PRE-TENSIONER", used along with a front seat belt, helps to reduce the risk or severity of injury to the driver and front passenger for certain types of collision. This system includes seat belt switch inputs and dual stage front air bag modules. The SRS system uses the seat belt switches to determine the front air bag deployment, and may only deploy one front air bag, depending on the severity of a collision and whether the front occupants are belted or unbelted. Information necessary to service the system safely is included in the SR and SB section of this Service Manual.

#### **WARNING:**

- To avoid rendering the SRS inoperative, which could increase the risk of personal injury or death in the event of a collision which would result in air bag inflation, all maintenance must be performed by an authorized NISSAN/INFINITI dealer.
- Improper maintenance, including incorrect removal and installation of the SRS, can lead to personal injury caused by unintentional activation of the system. For removal of Spiral Cable and Air Bag Module, see the SR section.
- Do not use electrical test equipment on any circuit related to the SRS unless instructed to in this Service Manual. SRS wiring harnesses can be identified by yellow and/or orange harnesses or harness connectors.

#### PRECAUTIONS WHEN USING POWER TOOLS (AIR OR ELECTRIC) AND HAMMERS

#### **WARNING:**

- When working near the Airbag Diagnosis Sensor Unit or other Airbag System sensors with the Ignition ON or engine running, DO NOT use air or electric power tools or strike near the sensor(s) with a hammer. Heavy vibration could activate the sensor(s) and deploy the air bag(s), possibly causing serious injury.
- When using air or electric power tools or hammers, always switch the Ignition OFF, disconnect the battery, and wait at least 3 minutes before performing any service.

#### Precaution Necessary for Steering Wheel Rotation After Battery Disconnect

INFOID:000000006392661

#### **NOTE:**

- Before removing and installing any control units, first turn the push-button ignition switch to the LOCK position, then disconnect both battery cables.
- After finishing work, confirm that all control unit connectors are connected properly, then re-connect both battery cables.
- Always use CONSULT to perform self-diagnosis as a part of each function inspection after finishing work. If a DTC is detected, perform trouble diagnosis according to self-diagnosis results.

This vehicle is equipped with a push-button ignition switch and a steering lock unit.

If the battery is disconnected or discharged, the steering wheel will lock and cannot be turned.

If turning the steering wheel is required with the battery disconnected or discharged, follow the procedure below before starting the repair operation.

#### OPERATION PROCEDURE

1. Connect both battery cables.

#### **NOTE:**

Supply power using jumper cables if battery is discharged.

2. Carry the Intelligent Key or insert it to the key slot and turn the push-button ignition switch to ACC position. (At this time, the steering lock will be released.)
3. Disconnect both battery cables. The steering lock will remain released with both battery cables disconnected and the steering wheel can be turned.
4. Perform the necessary repair operation.

# PRECAUTIONS

## < PRECAUTION >

5. When the repair work is completed, re-connect both battery cables. With the brake pedal released, turn the push-button ignition switch from ACC position to ON position, then to LOCK position. (The steering wheel will lock when the push-button ignition switch is turned to LOCK position.)
6. Perform self-diagnosis check of all control units using CONSULT.

## General Precautions

INFOID:000000006392662

- When installing rubber bushings, the final tightening must be carried out under unladen conditions with tires on ground. Oil might shorten the life of rubber bushings. Be sure to wipe off any spilled oil.
- Unladen conditions mean that fuel, engine coolant and lubricant are full. Spare tire, jack, hand tools and mats are in designated positions.
- After servicing suspension parts, be sure to check wheel alignment.
- Self-lock nuts are not reusable. Always use new ones when installing. Since new self-lock nuts are pre-oiled, tighten as they are.

A  
B  
C  
D  
F  
G  
H  
I  
J  
K  
L  
M  
N  
O  
P

**FSU**

# NOISE, VIBRATION AND HARSHNESS (NVH) TROUBLESHOOTING

< SYMPTOM DIAGNOSIS >

## SYMPTOM DIAGNOSIS

### NOISE, VIBRATION AND HARSHNESS (NVH) TROUBLESHOOTING

#### NVH Troubleshooting Chart

INFOID:000000006392663

Use the chart below to help you find the cause of the symptom. If necessary, repair or replace these parts.

Reference page		<a href="#">FSU-7</a>	<a href="#">FSU-7</a>	—	—	—	<a href="#">FSU-7</a>	<a href="#">FSU-7</a>	<a href="#">FSU-7</a>	<a href="#">WT-59. "NVH Troubleshooting Chart"</a>	<a href="#">WT-59. "NVH Troubleshooting Chart"</a>	<a href="#">FAX-2. "NVH Troubleshooting Chart"</a>	<a href="#">BR-6. "NVH Troubleshooting Chart"</a>	<a href="#">ST-5. "NVH Troubleshooting Chart"</a>
Possible cause and SUSPECTED PARTS		Improper installation, looseness	Shock absorber deformation, damage or deflection	Bushing or mounting deterioration	Parts interference	Spring fatigue	Suspension looseness	Incorrect wheel alignment	Stabilizer bar fatigue	TIRES	ROAD WHEEL	DRIVE SHAFT AND WHEEL HUB	BRAKES	STEERING
Symptom	Noise	x	x	x	x	x	x			x	x	x	x	x
	Shake	x	x	x	x		x			x	x	x	x	x
	Vibration	x	x	x	x	x				x		x		x
	Shimmy	x	x	x	x			x		x	x		x	x
	Shudder	x	x	x						x	x		x	x
	Poor quality ride or handling	x	x	x	x	x		x	x	x	x			

x: Applicable

# PREPARATION

< PREPARATION >

## PREPARATION

### PREPARATION

#### Special Service Tool

INFOID:000000006392664

The actual shapes of the Kent-Moore tools may differ from those of special service tools illustrated here.

Tool number (Kent-Moore No.) Tool name	Description
HT7252000 (J-25730-A) Ball joint remover	Removing tie-rod outer and lower ball joint
KV991040S1 ( — ) CCK gauge attachment <ol style="list-style-type: none"> <li>1. KV99104020 Adapter A</li> <li>2. KV99104030 Adapter B</li> <li>3. KV99104040 Adapter C</li> <li>4. KV99104050 Adapter D</li> <li>5. KV99104060 Plate</li> <li>6. KV99104070 Guide bolt</li> <li>7. KV99104080 Spring</li> <li>8. KV99104090 Center plate</li> </ol>	Measuring wheel alignment
ST35652000 ( — ) Strut attachment	Disassembling and assembling strut
— (J-44372) Pull gauge	Measuring steering wheel turning force and ball joint swinging force
KV101J0010 (J-47242) Engine support table	Front suspension member removal

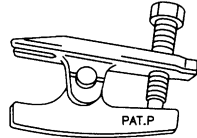

S-NT146

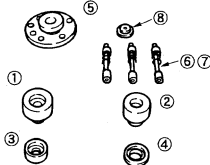

Z2A1167D

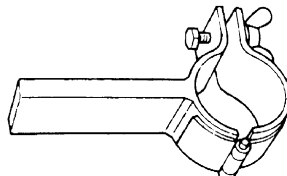

Z2A0807D

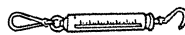

LST024

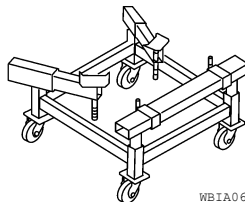

WBIA0658E

A  
B  
C  
D  
FSU  
F  
G  
H  
I  
J  
K  
L  
M  
N  
O  
P

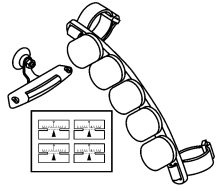
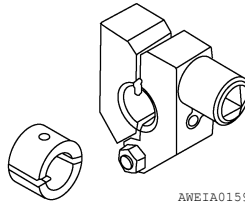

# PREPARATION

## < PREPARATION >

Tool number (Kent-Moore No.) Tool name	Description
<p>— (J-49286) Drift and Pull gauge</p>  <p style="text-align: right; font-size: small;">AWEIA01562Z</p>	Measuring drift and pull
<p>— (J-49029) Strut rod clamp</p>  <p style="text-align: right; font-size: small;">AWEIA01592Z</p>	Securing strut rod

## Commercial Service Tool

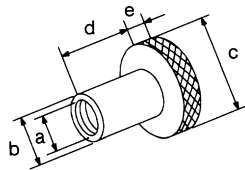
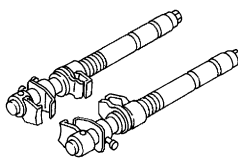
INFOID:000000006392665

Tool name	Description
<p>Power tool</p>  <p style="text-align: right; font-size: small;">PIIB1407E</p>	Loosening nuts, screws and bolts
<p>Attachment wheel alignment  a: screw M24 x 1.5 pitch  b: 35 mm (1.38 in) dia.  c: 65 mm (2.56 in) dia.  d: 56 mm (2.20 in) dia.  e: 12 mm (0.47 in) dia.</p>  <p style="text-align: right; font-size: small;">NT148</p>	Measure wheel alignment
<p>Spring compressor</p>  <p style="text-align: right; font-size: small;">NT717</p>	Removing and installing coil spring
<p>Engine slinger</p>  <p style="text-align: right; font-size: small;">LEIA0062E</p>	Removing and installing suspension member with VQ35DE and CVT

# FRONT SUSPENSION ASSEMBLY

< PERIODIC MAINTENANCE >

## PERIODIC MAINTENANCE

### FRONT SUSPENSION ASSEMBLY

#### Inspection and Adjustment

INFOID:000000006392666

#### INSPECTION

Make sure the mounting conditions (looseness, back lash) of each component and component conditions (wear, damage) are normal.

#### LOWER BALL JOINT END PLAY

1. Set front wheels in a straight-ahead position. Do not depress brake pedal.
2. Place an iron bar or similar tool between upper link and steering knuckle.
3. Measure axial end play by prying it up and down. Refer to [FSU-18, "Ball Joint"](#).

**CAUTION:**

**Be careful not to damage ball joint boot. Do not damage the installation position by applying excessive force.**

#### SHOCK ABSORBER

Check for oil leakage, damage and replace if malfunction is detected.

#### WHEEL ALIGNMENT

##### Description

Measure wheel alignment under unladen conditions.

**NOTE:**

"Unladen conditions" means that fuel, engine coolant, and lubricant are full. Spare tire, jack, hand tools and mats are in designated positions.

##### General Information and Recommendations

- A four-wheel thrust alignment should be performed.
- This type of alignment is recommended for any NISSAN vehicle.
- The four-wheel "thrust" process helps ensure that the vehicle is properly aligned and the steering wheel is centered.
- The alignment rack itself should be capable of accepting any NISSAN vehicle.
- The rack should be checked to ensure that it is level.
- Make sure the machine is properly calibrated.
- Your alignment equipment should be regularly calibrated in order to give correct information.
- Check with the manufacturer of your specific equipment for their recommended Service/Calibration Schedule.

##### Preliminary Check

Check the following:

1. Tires for improper air pressure and wear.
2. Road wheels for runout. Refer to [WT-69, "Road Wheel"](#).
3. Wheel bearing axial end play. Refer to [FAX-28, "Wheel Bearing"](#).
4. Transverse link ball joint axial end play. Refer to [FSU-11, "Removal and Installation"](#).
5. Shock absorber operation.
6. Each mounting part of axle and suspension for looseness and deformation.
7. Each of suspension member, shock absorber, upper link and transverse link for cracks, deformation and other damage.
8. Vehicle height (posture).

##### Alignment Process

**IMPORTANT:**

Use only the alignment specifications listed in this Service Manual.

- When displaying the alignment settings, many alignment machines use "indicators" **Do not use these indicators.**: (Green/red, plus or minus, Go/No Go).
- The alignment specifications programmed into your machine that operate these indicators may not be correct.

A  
B  
C  
D  
FSU  
F  
G  
H  
I  
J  
K  
L  
M  
N  
O  
P

## FRONT SUSPENSION ASSEMBLY

### < PERIODIC MAINTENANCE >

---

- This may result in an ERROR.
- Most camera-type alignment machines are equipped with both "Rolling Compensation" method and optional "Jacking Compensation" method to "compensate" the alignment targets or head units. "Rolling Compensation" is the preferred method.
- If using the "Rolling Compensation" method, after installing the alignment targets or head units, push or pull on the rear wheel to move the vehicle. Do not push or pull on the vehicle body.
- Use the "Jacking Compensation" method, after installing the alignment targets or head units, raise the vehicle and rotate the wheels 1/2 turn both ways.

### ADJUSTMENT

Camber, Caster and Kingpin Inclination Angles

**CAUTION:**

**Camber, caster, kingpin inclination angles cannot be adjusted.**



# FRONT COIL SPRING AND STRUT

< REMOVAL AND INSTALLATION >

## REMOVAL AND INSTALLATION

### FRONT COIL SPRING AND STRUT

#### Removal and Installation

INFOID:000000006392667

#### REMOVAL

1. Remove wheel and tire. Refer to [WT-65, "Adjustment"](#).
2. Remove wheel sensor electrical harness from strut. Refer to [BRC-64, "Removal and Installation"](#) (ABS), [BRC-136, "Removal and Installation"](#) (TCS/ABS), [BRC-253, "Removal and Installation"](#) (VDC/TCS/ABS).
3. Remove brake hose lock plate.
4. Remove stabilizer bar connecting rod end from strut. Refer to [FSU-13, "Exploded View"](#).
5. Remove steering knuckle to strut bolts and nuts. Refer to [FSU-13, "Exploded View"](#).
6. Remove bolt on strut tower bar then bolts on strut tower and remove strut from vehicle.

#### INSPECTION AFTER REMOVAL

Check the strut for any oil leakage or other damage and replace as necessary.

#### INSTALLATION

Installation is in the reverse order of removal.

- Refer to [FSU-13, "Exploded View"](#) for tightening torque.
- Be sure tab (A) on strut mount insulator is positioned as shown.

(A) : Tab

⇐ : Vehicle front

- Check wheel alignment. Refer to [FSU-7, "Inspection and Adjustment"](#).

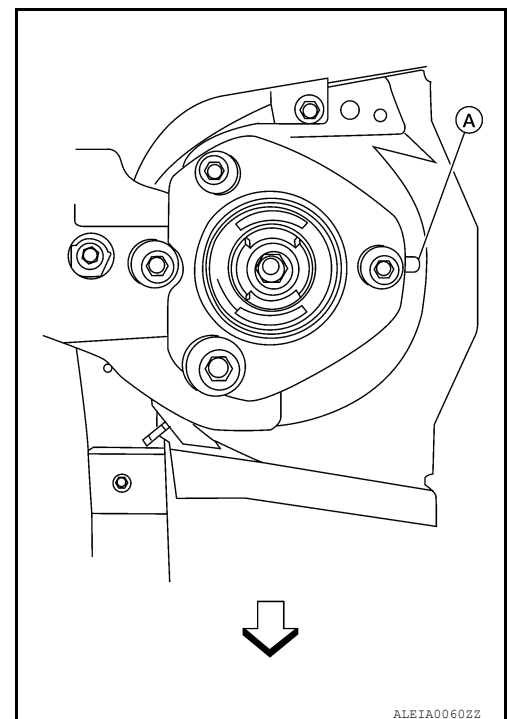

ALEIA00602Z

#### Disposal

INFOID:000000006392668

1. Set strut assembly horizontally with the piston rod fully extended.

## FRONT COIL SPRING AND STRUT

### < REMOVAL AND INSTALLATION >

2. Drill 2 – 3 mm (0.08 – 0.12 in) hole at the position (●) from top as shown in the figure to release gas gradually.

**CAUTION:**

- Wear eye protection (safety glasses).
- Wear gloves.
- Be careful with metal chips or oil blown out by the compressed gas.

**NOTE:**

- Drill vertically in this direction (⬇).
- Directly to the outer tube avoiding brackets.
- The gas is clear, colorless, odorless, and harmless.

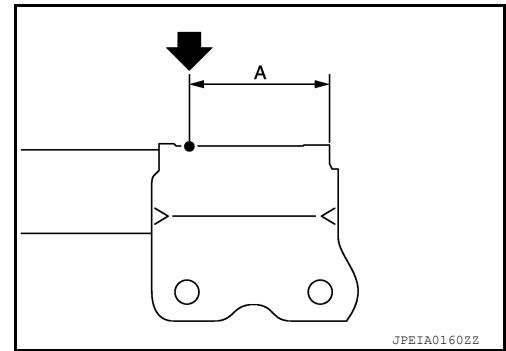

(A) : 20 – 30 mm (0.79 – 1.18 in)

3. Position the drilled hole downward and drain oil by moving the piston rod several times.

**CAUTION:**

**Dispose of drained oil according to the law and local regulations.**

# TRANSVERSE LINK

< REMOVAL AND INSTALLATION >

## TRANSVERSE LINK

### Removal and Installation

INFOID:000000006392669

#### REMOVAL

1. Remove wheel and tire using power tool. Refer to [WT-65, "Adjustment"](#).
2. Remove steering knuckle and hub assembly. Refer to [FAX-8, "Removal and Installation"](#).
3. Remove transverse link mounting bolts and nuts, and remove transverse link from suspension member.

#### INSPECTION AFTER REMOVAL

##### Visual Inspection

Check transverse link and bushing for deformation, cracks, and other damage. Replace the entire transverse link assembly if cracks, deformation or any other damage is found.

##### Ball Joint Inspection

##### **CAUTION:**

**Before measurement, move the ball joint at least ten times by hand to check for smooth movement.**

##### Swing Torque Inspection

- Hook Tool at cutout on ball stud. Confirm Tool measurement value is within specifications when ball stud begins moving.

⇐: Front

**Tool number** : — (J-44372)

**Swing torque** : Refer to [FSU-18, "Ball Joint"](#).

**Measurement on Tool** : Refer to [FSU-18, "Ball Joint"](#).

- If the value is outside the standard, replace transverse link.

##### Axial End Play Inspection

- Move tip of ball joint in axial direction to check for looseness.

**Axial end play** : Refer to [FSU-18, "Ball Joint"](#).

- If any looseness is noted, replace transverse link.

#### INSTALLATION

Installation is in the reverse order of removal.

- Refer to [FSU-13, "Exploded View"](#) for tightening torque specifications.
- Tighten transverse link mounting bolts with vehicle unladen and all four tire on flat, level ground.
- After installation, check the wheel alignment. Refer to [FSU-7, "Inspection and Adjustment"](#).

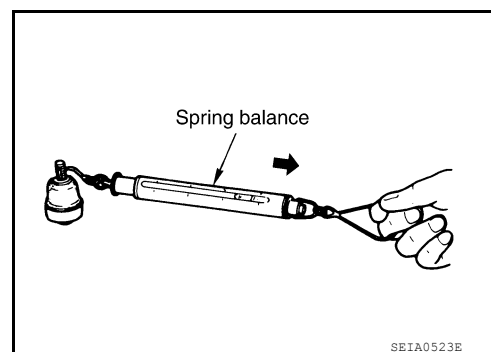

# FRONT STABILIZER

< REMOVAL AND INSTALLATION >

## FRONT STABILIZER

### Removal and Installation

INFOID:000000006392670

#### REMOVAL

1. Remove steering gear. Refer to [ST-17, "Removal and Installation"](#).
2. Remove mounting nuts on upper portion of stabilizer connecting rod.

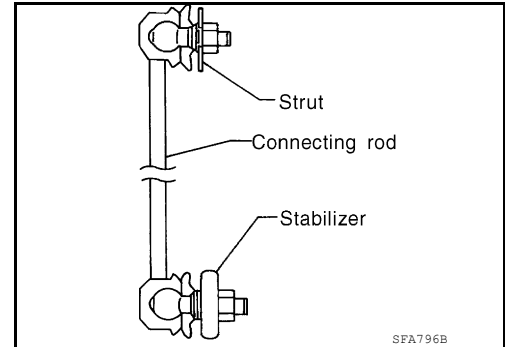

3. Remove stabilizer clamp bolts.
4. Remove stabilizer from the vehicle.

#### INSPECTION AFTER REMOVAL

Check stabilizer, connecting rod, bushing and clamp for deformation, cracks and damage, and replace if necessary.

#### INSTALLATION

Installation is in the reverse order of removal.

- Refer to [FSU-13, "Exploded View"](#) for tightening torque.
- When installing stabilizer, make sure that the clamps are facing in the direction shown.
- Make sure the cut surface of the bushing faces the rear.

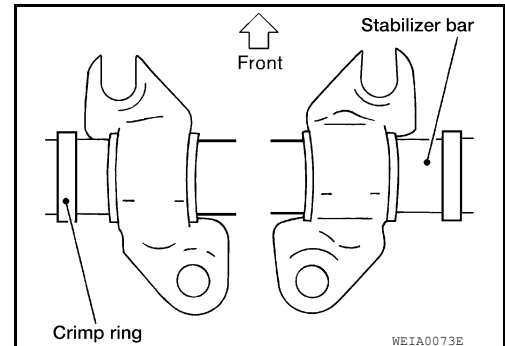

- Stabilizer uses pillow ball type connecting rod. Position ball joint with case on pillow ball head parallel to stabilizer.

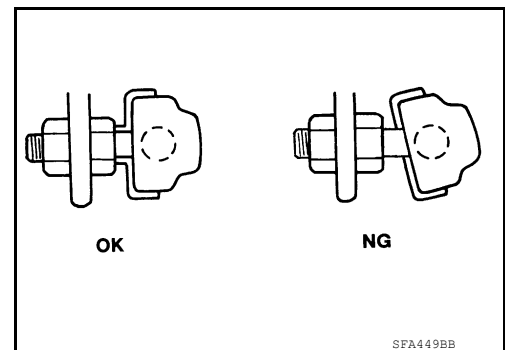

# FRONT SUSPENSION ASSEMBLY

< UNIT REMOVAL AND INSTALLATION >

## UNIT REMOVAL AND INSTALLATION

### FRONT SUSPENSION ASSEMBLY

Exploded View

INFOID:000000006392671

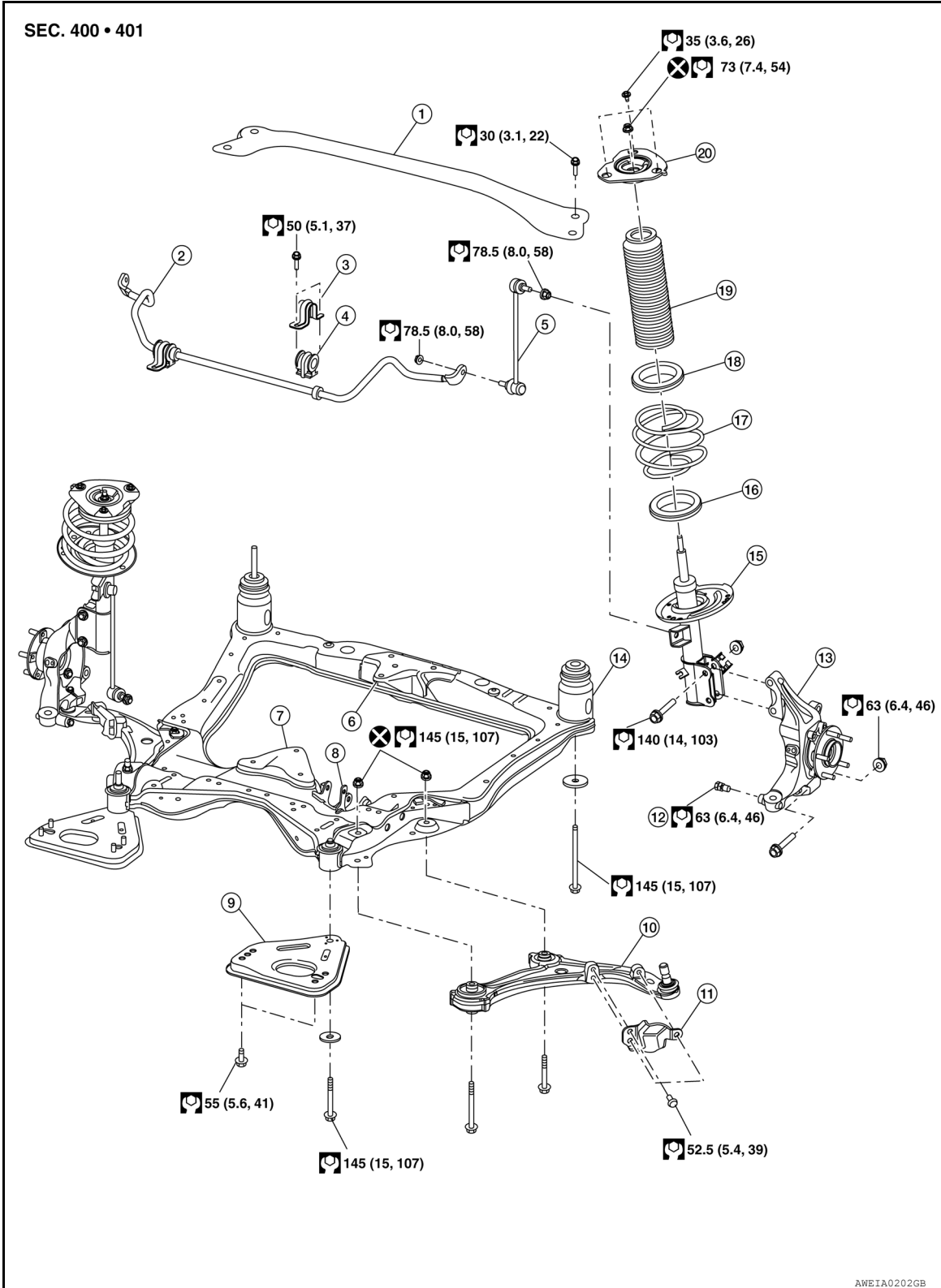

A

B

C

D

FSU

F

G

H

I

J

K

L

M

N

O

P

# FRONT SUSPENSION ASSEMBLY

## < UNIT REMOVAL AND INSTALLATION >

---

- |                              |                             |                               |
|------------------------------|-----------------------------|-------------------------------|
| 1. Strut tower bar           | 2. Stabilizer bar           | 3. Stabilizer clamp           |
| 4. Stabilizer bushing        | 5. Connecting rod           | 6. VQ35DE front mount bracket |
| 7. VQ35DE rear mount bracket | 8. QR25DE mount bracket     | 9. Member pin stay            |
| 10. Transverse link          | 11. Steering stop plate     | 12. Steering stop             |
| 13. Steering knuckle         | 14. Front suspension member | 15. Strut                     |
| 16. Lower rubber seat        | 17. Coil spring             | 18. Upper rubber seat         |
| 19. Dust cover               | 20. Strut mount insulator   |                               |

## Removal and Installation

INFOID:000000006392672

### REMOVAL

#### QR25DE Engine

1. Remove front wheels and tires. Refer to [WT-65, "Adjustment"](#).
2. Remove air duct and air cleaner assembly. Refer to [EM-25, "Removal and Installation"](#).
3. Remove engine under cover. Refer to [EXT-16, "Removal and Installation - Coupe"](#) (Coupe models) or [EXT-40, "Removal and Installation"](#) (Sedan models).
4. Remove nuts of stabilizer connecting rods from struts.
5. Remove pinch bolts then remove transverse links from steering knuckles using Tool.

**Tool number : HT7252000 (J-25730-A)**

6. Remove front exhaust tube. Refer to [EX-7, "Removal and Installation"](#).
7. Support engine or transmission with a jack.
8. Disconnect SSPS valve harness connector. Refer to [ST-17, "Exploded View"](#).
9. Remove steering gear bolts. Remove steering gear and power steering tube bracket from suspension member.
10. Hang steering gear.
11. Remove front and rear engine mount insulator bolts from suspension member.
12. Remove body-side bolts from member pin stay.
13. Set a jack under suspension member, and remove suspension member nuts.
14. Slowly lower jack to remove suspension member from vehicle.
15. If replacing suspension member, remove the following components from the suspension member.
  - transverse links.
  - stabilizer bar.
  - member pin stays.

#### VQ35DE Engine

Engine, transmission and suspension member must be removed as an assembly. Refer to [EM-203, "Removal and Installation"](#).

Once removed as an assembly, lift engine and transmission off of suspension member.

### INSTALLATION

Installation is in the reverse order of removal.

- Refer to [FSU-13, "Exploded View"](#) for tightening torque.
- After installation, perform final tightening of each part under unladen conditions with tires on ground. Check wheel alignment. Refer to [FSU-7, "Inspection and Adjustment"](#).

# FRONT COIL SPRING AND STRUT

< UNIT DISASSEMBLY AND ASSEMBLY >

## UNIT DISASSEMBLY AND ASSEMBLY

### FRONT COIL SPRING AND STRUT

#### Disassembly and Assembly

INFOID:000000006392673

#### DISASSEMBLY

1. Install Tool (A) to strut and secure it in a vise.

**Tool number (A) : ST35652000 ( — )**

**CAUTION:**

**When installing Tool, wrap a shop cloth around strut to protect it from damage.**

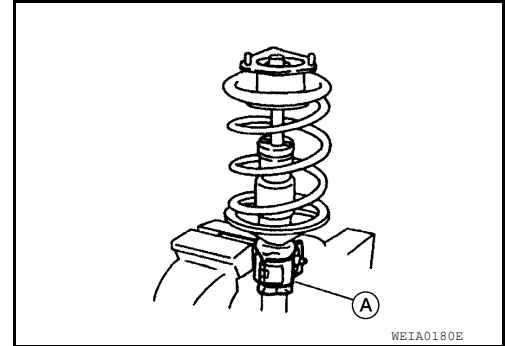

2. Install Tool to strut rod.

**Tool number : — (J-49029)**

3. Slightly loosen piston rod lock nut.

**WARNING:**

**Do not remove piston rod lock nut completely. If it is removed completely, the coil spring can jump out and may cause serious damage or injury.**

4. Compress coil spring using a commercially available spring compressor.

**WARNING:**

**Make sure that the pawls of the two spring compressors are firmly hooked on the spring. The spring compressors must be tightened alternately so as not to tilt the spring.**

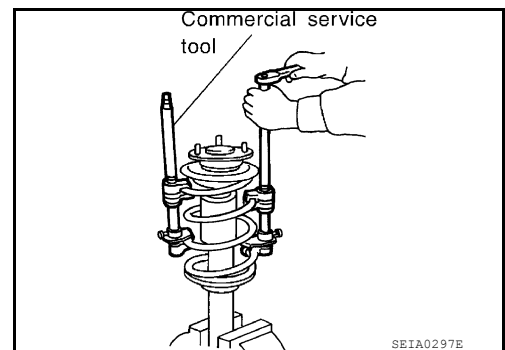

5. Making sure coil spring is free between upper and lower seats, then remove piston rod lock nut.
6. Remove small parts on strut.
  - Remove strut spacer, strut mount insulator, strut mounting insulator bracket thrust bearing, spring upper seat, and upper rubber seat. Then remove coil spring.
7. Remove bound bumper from spring upper seat.
8. Gradually release spring compressor (commercial service tool), and remove coil spring.

#### ASSEMBLY

## FRONT COIL SPRING AND STRUT

### < UNIT DISASSEMBLY AND ASSEMBLY >

1. Compress coil spring using a spring compressor (commercial service tool), and install it onto the strut.

**WARNING:**

Be sure spring compressor is securely attached to coil spring. Compress coil spring.

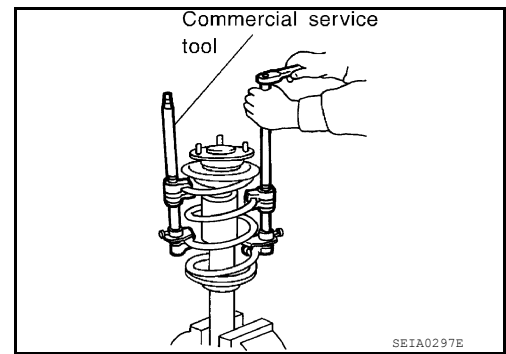

**CAUTION:**

Face tube side of coil spring downward. Align lower end to spring seat as shown.

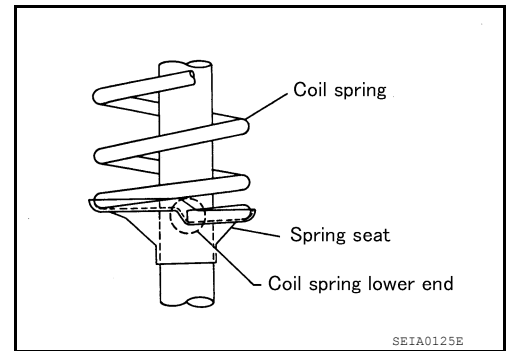

2. Connect bound bumper to spring upper seat.

**CAUTION:**

- Be sure to install bound bumper to spring upper seat securely.
- When installing bound bumper, use soapy water. Do not use machine oil or other lubricants.

3. Install small parts to the strut.

- Connect upper rubber seat, spring upper seats, thrust bearing, strut mount insulator, and strut spacer. Temporarily install piston rod lock nut.

**CAUTION:**

Do not reuse piston rod lock nut.

4. Be sure tab (A) on strut mount insulator is positioned as shown.

(A) : Tab

← : Vehicle front

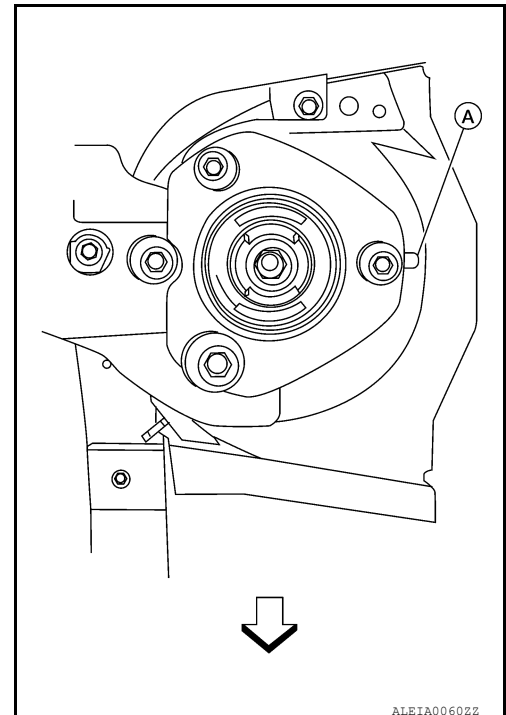



# FRONT COIL SPRING AND STRUT

## < UNIT DISASSEMBLY AND ASSEMBLY >

5. Be sure coil spring is properly set in spring rubber seat. Gradually release spring compressor.

**CAUTION:**

**Be sure upper rubber seat is properly aligned to spring upper seat and coil spring.**

6. Tighten piston rod lock nut to the specified torque. Refer to [FSU-13. "Exploded View"](#).

7. Remove Tool from strut.

**Tool number (A) : ST35652000 ( — )**

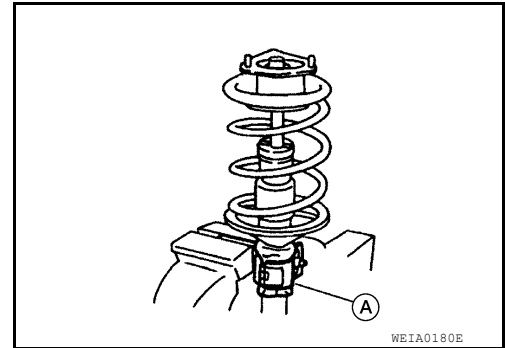

8. Remove Tool from strut rod.

**Tool number : — (J-49029)**

## Inspection

INFOID:000000006392674

### INSPECTION AFTER DISASSEMBLY

#### Strut

- Check strut for deformation, cracks, and damage, and replace if necessary.
- Check piston rod for damage, uneven wear, and distortion, and replace if necessary.
- Check welded and sealed areas for oil leakage, and replace if necessary.

#### Insulator and Rubber Parts

Check strut mount insulator for cracks and rubber parts for wear. Replace them if necessary.

#### Coil Spring

Check for cracks, wear, and damage, and replace if necessary.

A  
B  
C  
D  
FSU  
F  
G  
H  
I  
J  
K  
L  
M  
N  
O  
P

# SERVICE DATA AND SPECIFICATIONS (SDS)

< SERVICE DATA AND SPECIFICATIONS (SDS)

## SERVICE DATA AND SPECIFICATIONS (SDS)

### SERVICE DATA AND SPECIFICATIONS (SDS)

#### General Specification (Front)

INFOID:000000006392675

Suspension type	Independent strut with coil springs
Shock absorber type	Double-acting hydraulic

#### Wheel Alignment (Unladen \*1)

INFOID:000000006392676

Model		Sedan		Coupe	
Engine type		QR25DE	VQ35DE	QR25DE	VQ35DE
Tire size		205/65R16	215/55R17	215/55R17	235/45R18
Camber *2 Degree minute (Decimal degree)	LH	Minimum	-1°15' (-1.25°)		
		Nominal	-0°30' (-0.50°)		
		Maximum	0°15' (0.25°)		
	RH	Minimum	-1°30' (-1.50°)		
		Nominal	-0°45' (-0.75°)		
		Maximum	0°0' (0.00°)		
Caster *3 Degree minute (Decimal degree)		4°54' (4.90°)		4°36' (4.60°)	
Kingpin offset Degree minute (Decimal degree)	Minimum	11°57' (11.95°)		12°00' (12.00°)	
	Nominal	12°42' (12.70°)		12°45' (12.75°)	
	Maximum	13°27' (13.45°)		13°30' (13.50°)	

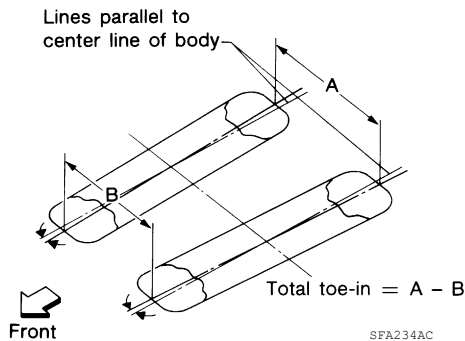

Total toe-in	Distance (A - B)	Minimum	0.0 mm (0.00 in)
		Nominal	1.0 mm (0.04 in) *4
		Maximum	2.0 mm (0.08 in)
Wheel turning angle	Refer to <a href="#">ST-34, "Steering Angle"</a> .		

\*1: Fuel, radiator coolant and engine oil full. Spare tire, jack, hand tools and mats in designated positions.

\*2: The RH camber angle shall be  $-0.25^\circ \pm 0.55^\circ$  with respect to the LH camber angle.

\*3: For the caster angle, the difference between right and left against the ground surface shall be  $\pm 0.55^\circ$  maximum.

\*4: Equivalent nominal degree minute (decimal degree) is  $0^\circ 3'$  (0.050°).

#### Ball Joint

INFOID:000000006392677

Swing torque	0.5 - 3.4 N·m (0.06 - 0.34 kg-m, 5 - 30 in-lb)
Measurement on spring balance (at cutout on ball stud)	7.94 - 53.97 N-f (0.81 - 5.50 kg-f, 1.79 - 12.2 lb-f)
Axial end play	0.1 mm (0.004 in) or less

# SERVICE DATA AND SPECIFICATIONS (SDS)

## < SERVICE DATA AND SPECIFICATIONS (SDS)

### Wheelarch Height (Unladen\*1)

INFOID:000000006392678

Unit: mm (in)

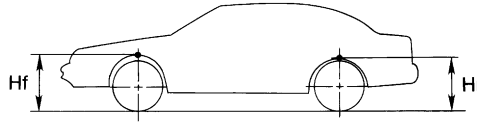

SFA818A

Model	Sedan		Coupe	
	QR25DE	VQ35DE	QR25DE	VQ35DE
Engine	QR25DE	VQ35DE	QR25DE	VQ35DE
Tire size	205/65R16	215/55R17	215/55R17	235/45R18
Front (Hf)	715 (28.15)	717 (28.23)	715 (28.15)	—
Rear (Hr)	716 (28.19)	713 (28.07)	723 (28.46)	—

\*1: Fuel, engine coolant and engine oil full. Spare tire, jack, hand tools and mats in designated positions.

A  
B  
C  
D  
E  
F  
G  
H  
I  
J  
K  
L  
M  
N  
O  
P

**FSU**