

A
EM
C
D
E
F
G
H
I
J
K
L
M
N
O
P

SECTION **EM**

ENGINE MECHANICAL

CONTENTS

QR25DE

PRECAUTION	4
PRECAUTIONS	4
Precaution for Supplemental Restraint System (SRS) "AIR BAG" and "SEAT BELT PRE-TENSIONER"	4
Precaution Necessary for Steering Wheel Rotation After Battery Disconnect	4
Precaution for Draining Coolant	5
Precaution for Disconnecting Fuel Piping	5
Precaution for Removal and Disassembly	5
Precaution for Inspection, Repair and Replacement	5
Precaution for Assembly and Installation	5
Parts Requiring Angular Tightening	5
Precaution for Liquid Gasket	5
PREPARATION	7
PREPARATION	7
Special Service Tool	7
Commercial Service Tool	9
SYSTEM DESCRIPTION	12
NOISE, VIBRATION, AND HARSHNESS (NVH) TROUBLESHOOTING	12
NVH Troubleshooting - Engine Noise	12
Use the Chart Below to Help You Find the Cause of the Symptom	13
PERIODIC MAINTENANCE	14
SPARK PLUG	14
Removal and Installation	14
DRIVE BELTS	16
Checking Drive Belts	16
Tension Adjustment	16
Removal and Installation	16
Removal and Installation of Drive Belt Auto-tensioner	17
AIR CLEANER FILTER	19
Removal and Installation	19
CAMSHAFT VALVE CLEARANCE	20
Camshaft valve clearance	20
COMPRESSION PRESSURE	23
Compression pressure	23
REMOVAL AND INSTALLATION	25
AIR CLEANER AND AIR DUCT	25
Removal and Installation	25
INTAKE MANIFOLD	26
Removal and Installation	26
EXHAUST MANIFOLD AND THREE WAY CATALYST	30
Removal and Installation	30
OIL PAN AND OIL STRAINER	32
Removal and Installation	32
IGNITION COIL	36
Removal and Installation	36
FUEL INJECTOR AND FUEL TUBE	37
Removal and Installation	37
ROCKER COVER	40
Removal and Installation	40
CAMSHAFT	42
Removal and Installation	42
Inspection After Installation	49
Valve Clearance	50
INTAKE VALVE TIMING CONTROL	53
Intake Valve Timing Control Solenoid Valve	53

TIMING CHAIN	54	NOISE, VIBRATION, AND HARSHNESS	
Removal and Installation	54	(NVH) TROUBLESHOOTING	119
OIL SEAL	63	NVH Troubleshooting - Engine Noise	119
Removal and Installation of Valve Oil Seal	63	Use the Chart Below to Help You Find the Cause	
Removal and Installation of Front Oil Seal	63	of the Symptom	120
Removal and Installation of Rear Oil Seal	64	PERIODIC MAINTENANCE	121
CYLINDER HEAD	66	SPARK PLUG	121
Removal and Installation	66	Removal and Installation	121
Disassembly and Assembly	68	DRIVE BELTS	123
Inspection After Disassembly	70	Checking Drive Belts	123
UNIT REMOVAL AND INSTALLATION	74	Tension Adjustment	123
ENGINE ASSEMBLY	74	Removal and Installation	123
Removal and Installation	74	Removal and Installation of Drive Belt Auto-ten-	
UNIT DISASSEMBLY AND ASSEMBLY ...	78	sioner	124
CYLINDER BLOCK	78	AIR CLEANER FILTER	126
Disassembly and Assembly	78	Removal and Installation	126
Inspection After Disassembly	86	CAMSHAFT VALVE CLEARANCE	127
HOW TO SELECT PISTON AND BEARING	95	Valve Clearance	127
How to Select Piston and Bearing	95	COMPRESSION PRESSURE	131
SERVICE DATA AND SPECIFICATIONS		On-Vehicle Service	131
(SDS)	101	REMOVAL AND INSTALLATION	132
SERVICE DATA AND SPECIFICATIONS		AIR CLEANER AND AIR DUCT	132
(SDS)	101	Removal and Installation	132
Standard and Limit	101	INTAKE MANIFOLD COLLECTOR	133
		Removal and Installation	133
		INTAKE MANIFOLD	136
		Removal and Installation	136
		EXHAUST MANIFOLD AND THREE WAY	
		CATALYST	139
		Exploded View	139
		Removal and Installation (LH)	140
		Removal and Installation (RH)	141
		OIL PAN AND OIL STRAINER	144
		Exploded View	144
		Removal and Installation (Lower Oil Pan)	144
		Removal and Installation (Upper Oil Pan)	145
		IGNITION COIL	150
		Exploded View	150
		Removal and Installation LH	150
		Removal and Installation RH	150
		FUEL INJECTOR AND FUEL TUBE	152
		Removal and Installation	152
		ROCKER COVER	157
		Exploded View	157
		Removal and Installation LH	157
		Removal and Installation RH	158
PRECAUTION	112		
PRECAUTIONS	112		
Precaution for Supplemental Restraint System			
(SRS) "AIR BAG" and "SEAT BELT PRE-TEN-			
SIONER"	112		
Precaution Necessary for Steering Wheel Rota-			
tion After Battery Disconnect	112		
Precaution for Drain Coolant	113		
Precaution for Disconnecting Fuel Piping	113		
Precaution for Removal and Disassembly	113		
Precaution for Inspection, Repair and Replace-			
ment	113		
Precaution for Assembly and Installation	113		
Parts Requiring Angular Tightening	113		
Precaution for Liquid Gasket	113		
PREPARATION	115		
PREPARATION	115		
Special Service Tool	115		
Commercial Service Tool	117		
SYSTEM DESCRIPTION	119		

VQ35DE

INTAKE VALVE TIMING CONTROL	161	ENGINE MOUNT	207	A
Exploded View	161	ENGINE MOUNT (FRONT)	207	
Intake Valve Timing Control Solenoid Valve (LH)		ENGINE MOUNT (FRONT) : Removal and Instal-		
(bank 2)	161	lation	207	EM
Intake Valve Timing Control Solenoid Valve (RH)		UNIT REMOVAL AND INSTALLATION ...	210	
(bank 1)	162	ENGINE ASSEMBLY	210	C
FRONT TIMING CHAIN CASE	163	Removal and Installation	210	
Removal and Installation	163	UNIT DISASSEMBLY AND ASSEMBLY .	214	D
TIMING CHAIN	171	CYLINDER BLOCK	214	
Component	171	Disassembly and Assembly	214	E
Removal	171	Inspection	225	
Inspection	174	Dowel Pin Alignment	234	
Installation	174	SERVICE DATA AND SPECIFICATIONS		F
REAR TIMING CHAIN CASE	179	(SDS)	236	
Component	179	SERVICE DATA AND SPECIFICATIONS		G
Removal and Installation	180	(SDS)	236	
CAMSHAFT	184	General Specification	236	H
Removal and Installation	184	Drive Belt	236	
Inspection after Installation	192	Spark Plug	237	I
OIL SEAL	193	Intake Manifold	237	
Removal and Installation of Valve Oil Seal	193	Exhaust Manifold	237	J
Removal and Installation of Front Oil Seal	193	Camshaft	237	
Removal and Installation of Rear Oil Seal	195	Cylinder Head	239	K
CYLINDER HEAD	197	Cylinder Block	243	
Removal and Installation	197	Main Bearing	246	L
Disassembly and Assembly	200	Connecting Rod Bearing	247	M
Inspection After Disassembly	202	Drive Plate	248	N
				O
				P

PRECAUTION

PRECAUTIONS

Precaution for Supplemental Restraint System (SRS) "AIR BAG" and "SEAT BELT PRE-TENSIONER"

INFOID:000000007420213

The Supplemental Restraint System such as "AIR BAG" and "SEAT BELT PRE-TENSIONER", used along with a front seat belt, helps to reduce the risk or severity of injury to the driver and front passenger for certain types of collision. This system includes seat belt switch inputs and dual stage front air bag modules. The SRS system uses the seat belt switches to determine the front air bag deployment, and may only deploy one front air bag, depending on the severity of a collision and whether the front occupants are belted or unbelted. Information necessary to service the system safely is included in the SR and SB section of this Service Manual.

WARNING:

- To avoid rendering the SRS inoperative, which could increase the risk of personal injury or death in the event of a collision which would result in air bag inflation, all maintenance must be performed by an authorized NISSAN/INFINITI dealer.
- Improper maintenance, including incorrect removal and installation of the SRS, can lead to personal injury caused by unintentional activation of the system. For removal of Spiral Cable and Air Bag Module, see the SR section.
- Do not use electrical test equipment on any circuit related to the SRS unless instructed to in this Service Manual. SRS wiring harnesses can be identified by yellow and/or orange harnesses or harness connectors.

PRECAUTIONS WHEN USING POWER TOOLS (AIR OR ELECTRIC) AND HAMMERS

WARNING:

- When working near the Airbag Diagnosis Sensor Unit or other Airbag System sensors with the Ignition ON or engine running, DO NOT use air or electric power tools or strike near the sensor(s) with a hammer. Heavy vibration could activate the sensor(s) and deploy the air bag(s), possibly causing serious injury.
- When using air or electric power tools or hammers, always switch the Ignition OFF, disconnect the battery, and wait at least 3 minutes before performing any service.

Precaution Necessary for Steering Wheel Rotation After Battery Disconnect

INFOID:000000007420214

NOTE:

- Before removing and installing any control units, first turn the push-button ignition switch to the LOCK position, then disconnect both battery cables.
- After finishing work, confirm that all control unit connectors are connected properly, then re-connect both battery cables.
- Always use CONSULT to perform self-diagnosis as a part of each function inspection after finishing work. If a DTC is detected, perform trouble diagnosis according to self-diagnosis results.

This vehicle is equipped with a push-button ignition switch and a steering lock unit.

If the battery is disconnected or discharged, the steering wheel will lock and cannot be turned.

If turning the steering wheel is required with the battery disconnected or discharged, follow the procedure below before starting the repair operation.

OPERATION PROCEDURE

1. Connect both battery cables.

NOTE:

Supply power using jumper cables if battery is discharged.

2. Carry the Intelligent Key or insert it to the key slot and turn the push-button ignition switch to ACC position. (At this time, the steering lock will be released.)
3. Disconnect both battery cables. The steering lock will remain released with both battery cables disconnected and the steering wheel can be turned.
4. Perform the necessary repair operation.

PRECAUTIONS

[QR25DE]

< PRECAUTION >

- When the repair work is completed, re-connect both battery cables. With the brake pedal released, turn the push-button ignition switch from ACC position to ON position, then to LOCK position. (The steering wheel will lock when the push-button ignition switch is turned to LOCK position.)
- Perform self-diagnosis check of all control units using CONSULT.

Precaution for Draining Coolant

INFOID:000000007420215

- Drain coolant when engine is cooled.

Precaution for Disconnecting Fuel Piping

INFOID:000000007420216

- Before starting work, make sure no fire or spark producing items are in the work area.
- Release fuel pressure before any removal or disassembly.
- After disconnecting pipes, plug openings to stop fuel leakage.

Precaution for Removal and Disassembly

INFOID:000000007420217

- When instructed to use special service tools, use the specified tools. Always be careful to work safely, avoid forceful operations.
- Use maximum care to avoid damage to mating or sliding surfaces.
- Cover openings of engine system with tape or equivalent, if necessary, to seal out foreign materials.
- Mark and arrange disassembly parts in an organized way for easy troubleshooting and assembly.
- When loosening nuts and bolts, as a basic rule, start with the one furthest outside, then the one diagonally opposite, and so on. If the order of loosening is specified, follow the specifications.

Precaution for Inspection, Repair and Replacement

INFOID:000000007420218

- Before repairing or replacing, thoroughly inspect parts. Inspect new replacement parts in the same way, and replace if necessary.

Precaution for Assembly and Installation

INFOID:000000007420219

- Use torque wrench to tighten bolts or nuts.
- When tightening nuts and bolts, as a basic rule, equally tighten in several different steps starting with the ones in center, then ones on inside and outside diagonally in this order. If the order of tightening is specified, follow the specifications.
- Always replace the old with a new gasket, packing, oil seal or O-ring.
- Thoroughly wash, clean, and air-blow each part. Carefully check oil or coolant passages for any restriction and blockage.
- Avoid damaging sliding or mating surfaces. Completely remove foreign materials such as cloth lint or dust. Before assembly, oil sliding surfaces well.
- Bleed the air trapped within the system after draining the coolant.
- Before starting engine, apply fuel pressure to fuel lines with turning ignition switch ON (with engine stopped). Then make sure that there are no leaks at fuel line connections.
- After repairing, start engine and increase engine speed to check coolant, fuel, oil, and exhaust systems for leakage or rattles.

Parts Requiring Angular Tightening

INFOID:000000007420220

- Use an angle wrench for the final tightening of the following engine parts.
 - Cylinder head bolts
 - Lower cylinder block bolts
 - Connecting rod cap bolts
 - Crankshaft pulley bolt (No angle wrench is required as the bolt flange is provided with notches for angular tightening)
- Do not use a torque value for final tightening.
- The torque value for these parts are for a preliminary step.
- Ensure thread and seat surfaces are clean and coated with engine oil.

Precaution for Liquid Gasket

INFOID:000000007420221

REMOVAL OF LIQUID GASKET SEALANT

PRECAUTIONS

[QR25DE]

< PRECAUTION >

- After removing the bolts and nuts, separate the mating surface and remove the old liquid gasket sealant using Tool.

Tool number : KV10111100 (J-37228)

CAUTION:

Do not damage mating surfaces.

- Tap the seal cutter to insert it (1).
- In areas where the Tool is difficult to use, lightly tap to slide it (2).

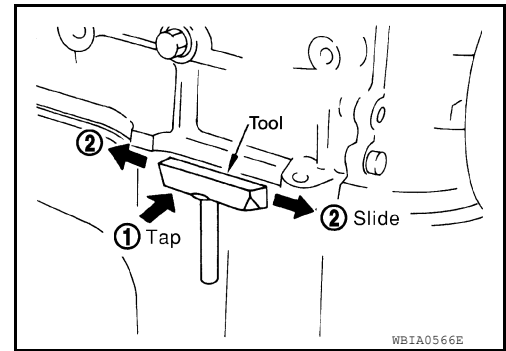

LIQUID GASKET APPLICATION PROCEDURE

1. Using a scraper, remove the old Silicone RTV Sealant adhering to the gasket application surface and the mating surface.
 - Remove the sealant completely from the groove of the gasket application surface, mounting bolts, and bolt holes.
2. Thoroughly clean the gasket application surface and the mating surface and remove adhering moisture, grease and foreign materials.

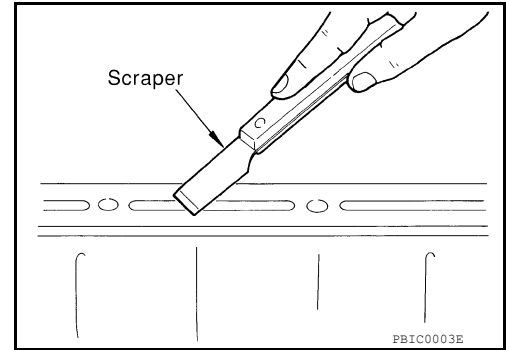

3. Attach the sealant tube to the tube presser.
Use Genuine Silicone RTV Sealant or equivalent. Refer to [GI-15, "Recommended Chemical Products and Sealants"](#).

Tube presser WS39930000 (-)

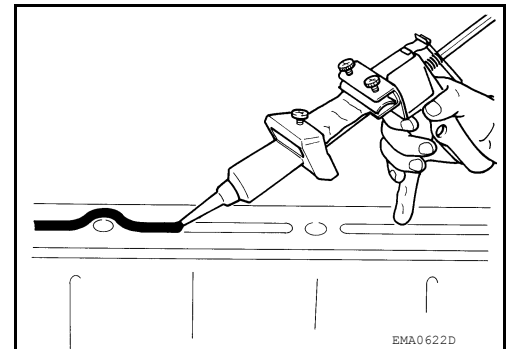

4. Apply the sealant using Tool without breaks to the specified location.
 - If there is a groove for the sealant application, apply the sealant to the groove.
 - As for the bolt holes, normally apply the sealant inside the holes. If specified, it should be applied outside the holes. Make sure to read the text of this manual.
 - Within five minutes of the sealant application, install the mating component.
 - If the sealant protrudes, wipe it off immediately.
 - Do not retighten after the installation.
 - After 30 minutes or more have passed from the installation, fill the engine with the specified oil and coolant. Refer to [MA-12, "Fluids and Lubricants"](#).

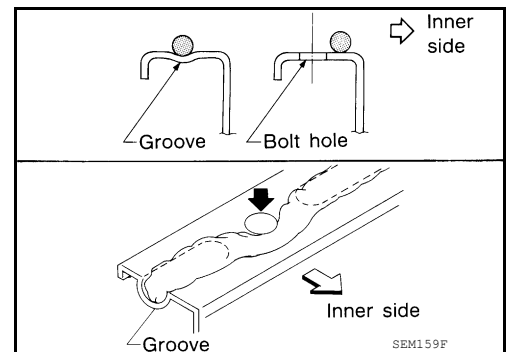

CAUTION:

Carefully follow all of the warnings, cautions, notes, and procedures contained in this manual.

PREPARATION

< PREPARATION >

[QR25DE]

PREPARATION

PREPARATION

Special Service Tool

INFOID:000000007420222

A

EM

The actual shapes of the Kent-Moore tools may differ from those of the special service tools illustrated here.

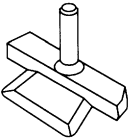
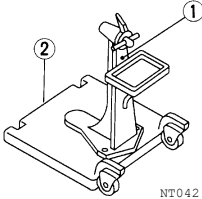
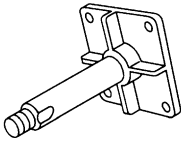
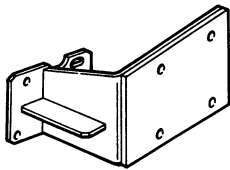
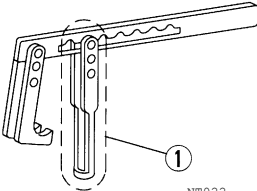
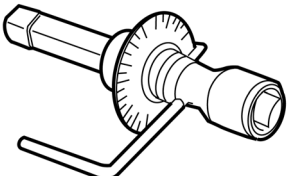
Tool number (Kent-Moore No.) Tool name	Description
KV10111100 (J-37228) Seal cutter	Removing steel oil pan and rear timing chain case  <p style="text-align: center;">S-NT046</p>
ST0501S000 Engine stand assembly 1. ST05011000 (—) Engine stand 2. ST05012000 (—) Base	Disassembling and assembling  <p style="text-align: center;">NT042</p>
KV10106500 (—) Engine stand shaft	 <p style="text-align: center;">NT028</p>
KV10115300 (—) Engine sub-attachment	 <p style="text-align: center;">ZZA1078D</p>
KV10116200 (J-26336-B) Valve spring compressor 1. KV10115900 (J-26336-20) Attachment	Disassembling valve mechanism  <p style="text-align: center;">NT022</p>
KV10112100 (BT-8653-A) Angle wrench	Tightening bolts for bearing cap, cylinder head, etc.  <p style="text-align: center;">ANBIA10432Z</p>

C

D

E

F

G

H

I

J

K

L

M

N

O

P

PREPARATION

< PREPARATION >



[QR25DE]

Tool number (Kent-Moore No.) Tool name	Description
KV10107902 (J-38959) Valve oil seal puller	Removing valve oil seal
KV10115600 (J-38958) Valve oil seal drift	Installing valve oil seal Use side A. a: 20 (0.79) dia. d: 8 (0.31) dia. b: 13 (0.51) dia. e: 10.7 (0.421) dia. c: 10.3 (0.406) dia. f: 5 (0.20) dia. Unit: mm (in)
EM03470000 (J-8037) Piston ring compressor	Installing piston assembly into cylinder bore
ST16610001 (J-23907) Pilot bushing puller	Removing crankshaft pilot bushing
WS39930000 (—) Tube presser	Pressing the tube of liquid gasket
16441 6N210 (J-45488) Quick connector release	Removing fuel tube quick connectors in engine room (Available in SEC. 164 of PARTS CATALOG: Part No. 16441 6N210)
KV10117100 (J-36471-A) Heated oxygen sensor wrench	Loosening or tightening heated oxygen sensor For 22 mm (0.87 in) hexagon nut

PREPARATION

< PREPARATION >

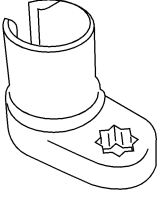
[QR25DE]

Tool number (Kent-Moore No.) Tool name	Description	
KV991J0050 (J-44626) Air fuel ratio (A/F) sensor wrench	 <p style="text-align: center; font-size: small;">LEM054</p>	Loosening or tightening air fuel ratio (A/F) sensor 1
— (J-46535) Drive belt tension releaser	 <p style="text-align: center; font-size: small;">WBIA0536E</p>	Releasing drive belt tension

A
EM

C

D

E

F

Commercial Service Tool

INFOID:000000007420223

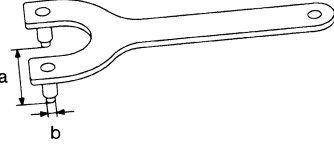
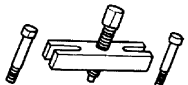
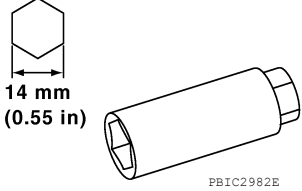
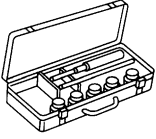
(Kent-Moore No.) Tool name	Description	
Pulley holder	 <p style="text-align: center; font-size: x-small;">NT628</p>	Crankshaft pulley removing and installing a: 68 mm (2.68 in) dia. b: 8 mm (0.31 in) dia.
Crank puller	 <p style="text-align: center; font-size: x-small;">ZZA0010D</p>	Crankshaft pulley removing
Spark plug wrench	 <p style="text-align: center; font-size: x-small;">PBIC2982E</p>	Removing and installing spark plug
Valve seat cutter set	 <p style="text-align: center; font-size: x-small;">S-NT048</p>	Finishing valve seat dimensions

G

H

I

J

K

L

M

N



O

P

PREPARATION

[QR25DE]

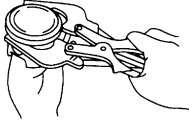
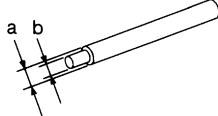
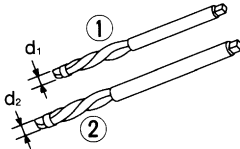
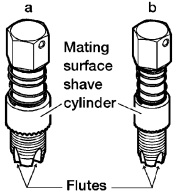
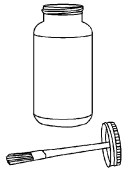
< PREPARATION >

(Kent-Moore No.) Tool name	Description
Piston ring expander  <small>S-NT030</small>	Removing and installing piston ring
Valve guide drift  <small>S-NT015</small>	Removing and installing valve guide Intake & Exhaust: a: 9.5 mm (0.374 in) dia. b: 5.5 mm (0.217 in) dia.
Valve guide reamer  <small>S-NT016</small>	1: Reaming valve guide inner hole 2: Reaming hole for oversize valve guide Intake & Exhaust: d1: 6.0 mm (0.236 in) dia. d2: 10.2 mm (0.402 in) dia.
(J-43897-18) (J-43897-12) Oxygen sensor thread cleaner  <small>AEM488</small>	Reconditioning the exhaust system threads before installing a new heated oxygen sensor (Use with anti-seize lubricant shown below.) a: J-43897-18 [18 mm (0.71 in) dia.] for zirconia heated oxygen sensor b: J-43897-12 [12 mm (0.47 in) dia.] for titania heated oxygen sensor
Anti-seize lubricant (Permatex 133AR or equivalent meeting MIL specification MIL-A-907)  <small>AEM489</small>	Lubricating oxygen sensor thread cleaning tool when reconditioning exhaust system threads
Power tool  <small>PIIB1407E</small>	Loosening nuts, screws and bolts

PREPARATION

< PREPARATION >

[QR25DE]

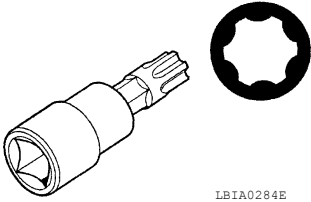
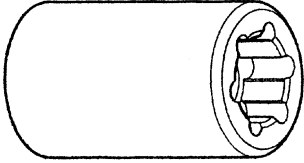
(Kent-Moore No.) Tool name	Description
<p>TP55 Bit</p>  <p style="text-align: center;">LBIA0284E</p>	<p>Removing and installing M/T flywheel bolts</p>
<p>(J-45816) E20 Socket</p>  <p style="text-align: center;">LBIA0285E</p>	<p>Removing and installing CVT drive plate bolts</p>

A

EM

C

D

E

F

G

H

I

J

K

L

M

N

O

P

SYSTEM DESCRIPTION

NOISE, VIBRATION, AND HARSHNESS (NVH) TROUBLESHOOTING

NVH Troubleshooting - Engine Noise

INFOID:000000007420224

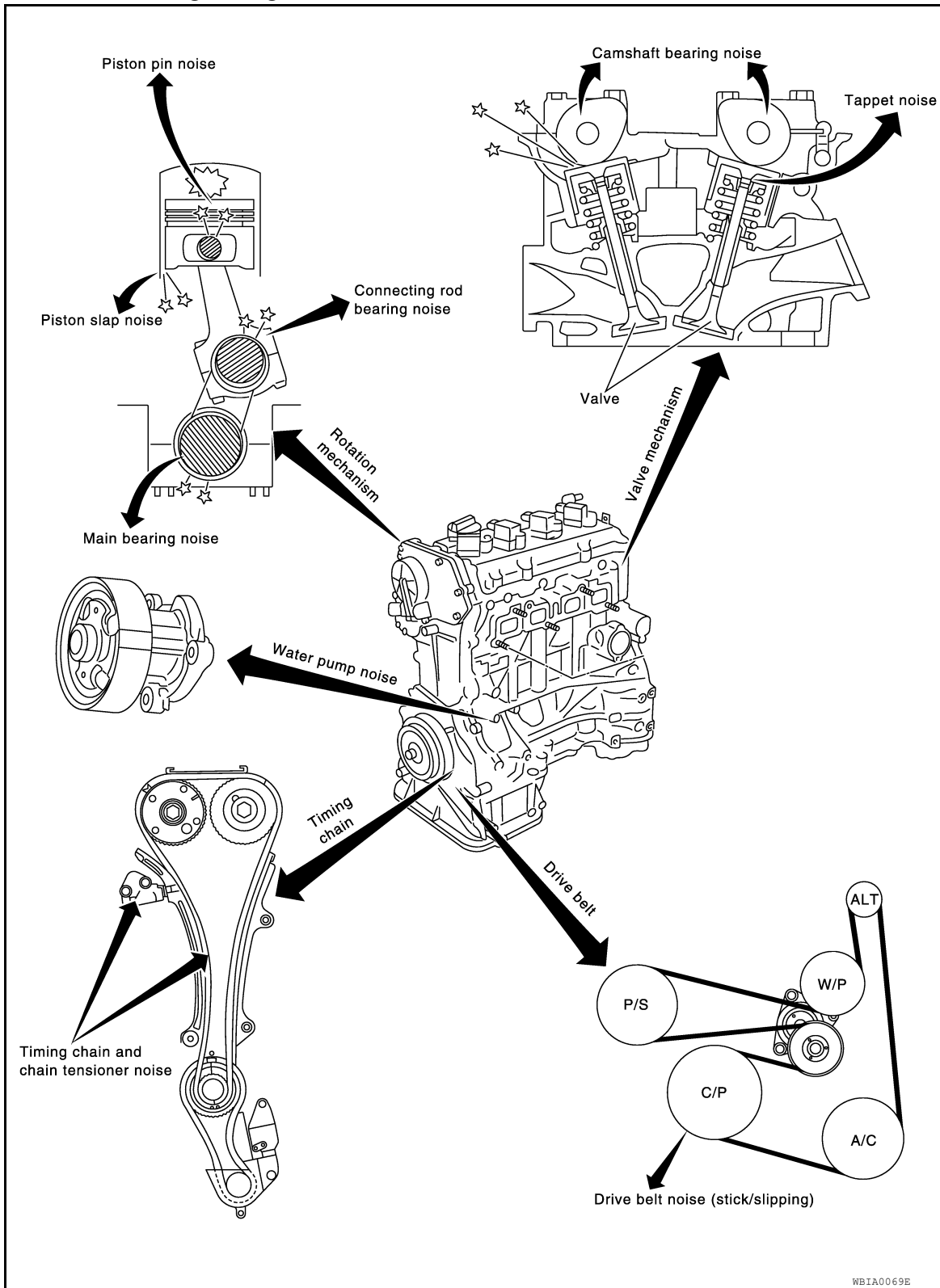

WBIA0069E

NOISE, VIBRATION, AND HARSHNESS (NVH) TROUBLESHOOTING

< SYSTEM DESCRIPTION >

[QR25DE]

Use the Chart Below to Help You Find the Cause of the Symptom

INFOID:000000007420225

1. Locate the area where noise occurs.
2. Confirm the type of noise.
3. Specify the operating condition of engine.
4. Check specified noise source.

If necessary, repair or replace these parts.

Location of noise	Type of noise	Operating condition of engine						Source of noise	Check item	Reference page
		Before warm-up	After warm-up	When starting	When idling	When racing	While driving			
Top of engine Rocker cover Cylinder head	Ticking or clicking	C	A	—	A	B	—	Tappet noise	Valve clearance	EM-50
	Rattle	C	A	—	A	B	C	Camshaft bearing noise	Camshaft journal clearance Camshaft runout	EM-42 EM-42
Crankshaft pulley Cylinder block (Side of engine) Oil pan	Slap or knock	—	A	—	B	B	—	Piston pin noise	Piston and piston pin clearance Connecting rod bushing clearance	EM-86 EM-86
	Slap or rap	A	—	—	B	B	A	Piston slap noise	Piston-to-bore clearance Piston ring side clearance Piston ring end gap Connecting rod bend and torsion	EM-86 EM-86 EM-86 EM-86
	Knock	A	B	C	B	B	B	Connecting rod bearing noise	Connecting rod bushing clearance (Small end) Connecting rod bearing clearance (Big end)	EM-86 EM-86
	Knock	A	B	—	A	B	C	Main bearing noise	Main bearing oil clearance Crankshaft runout	EM-86 EM-86
Front of engine Timing chain cover	Tapping or ticking	A	A	—	B	B	B	Timing chain and chain tensioner noise	Timing chain cracks and wear Timing chain tensioner operation	EM-54
Front of engine	Squeaking or fizzing	A	B	—	B	—	B	Drive belts (Sticking or slipping)	Drive belts deflection	EM-16
	Creaking	A	B	A	B	A	B	Drive belts (Slipping)	Idler pulley bearing operation	
	Squall Creak	A	B	—	B	A	B	Water pump noise	Water pump operation	CO-18

A: Closely related B: Related C: Sometimes related —: Not related

SPARK PLUG

< PERIODIC MAINTENANCE >

[QR25DE]

PERIODIC MAINTENANCE

SPARK PLUG

Removal and Installation

INFOID:000000007420226

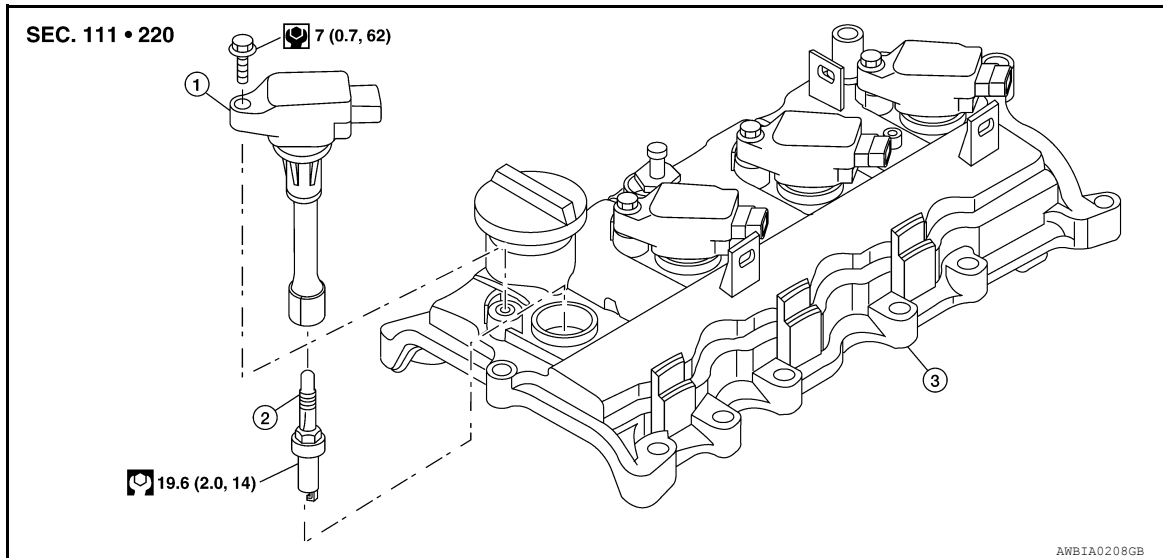

1. Ignition coil

2. Spark plug

3. Rocker cover

REMOVAL

1. Remove engine room cover.
2. Remove the ignition coil. Refer to [EM-36. "Removal and Installation"](#).
3. Remove the spark plug with a suitable tool.

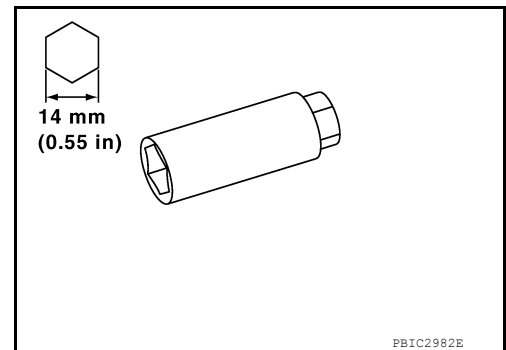

INSPECTION AFTER REMOVAL

- Do not use a wire brush for cleaning the spark plugs. Replace as necessary.

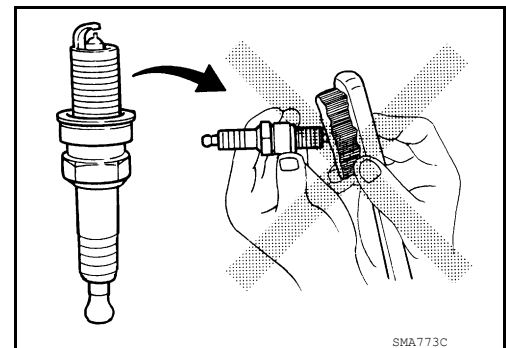

- If plug is covered with carbon, a spark plug cleaner may be used.

SPARK PLUG

< PERIODIC MAINTENANCE >

[QR25DE]

Cleaner air pressure : less than 588 kPa (5.88 bar, 6 kg/cm², 85 psi)

Cleaning time : less than 20 seconds

- Checking and adjusting plug gap is not required between change intervals. If the gap is out of specification, replace the spark plug.

Gap (nominal) : 1.1 mm (0.043 in)

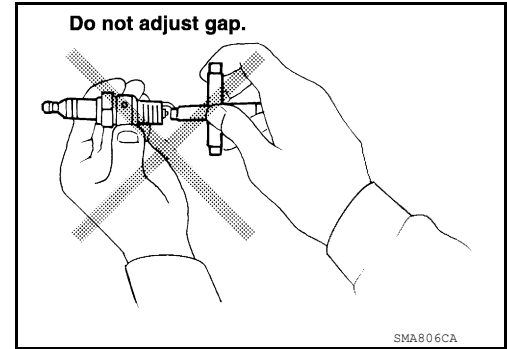

INSTALLATION

Installation is in the reverse order of removal.

Standard type*	NGK
	DILKAR6A-11
Gap (nominal)	1.1 mm (0.043 in)

*: Always check with the Parts Department for the latest parts information.

A
EM
C
D
E
F
G
H
I
J
K
L
M
N
O
P

DRIVE BELTS

Checking Drive Belts

INFOID:000000007420227

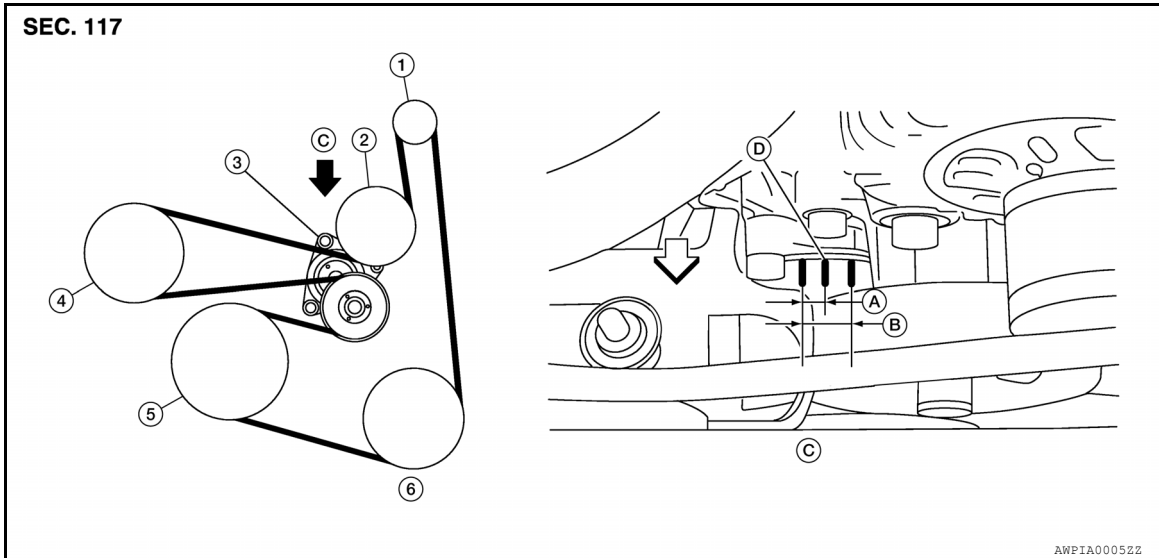

- | | | |
|-------------------------------|------------------------|------------------------------|
| 1. Generator pulley | 2. Water pump pulley | 3. Drive belt auto-tensioner |
| 4. Power steering pump pulley | 5. Crankshaft pulley | 6. A/C compressor pulley |
| A. New drive belt range | B. Allowable use range | C. View C |
| D. Indicator (notch) | ← Engine front | |

WARNING:

Inspect the drive belt only when the engine is stopped.

- Make sure that the stamp mark of drive belt auto-tensioner is within the usable range.

NOTE:

- Check the drive belt auto-tensioner indicator (notch) when the engine is cold.
- When the new drive belt is installed, the range should be (A) as shown.
- Visually check entire belt for wear, damage or cracks.
- If the indicator is out of allowable use range or belt is damaged, replace the belt.

Tension Adjustment

INFOID:000000007420228

- Belt tension is not manually adjustable, it is automatically adjusted by the drive belt auto-tensioner.

Removal and Installation

INFOID:000000007420229

REMOVAL

1. Remove the fender protector side cover (RH). Refer to [EXT-22, "Removal and Installation"](#) (Coupe models) or [EXT-46, "Removal and Installation"](#) (Sedan models).
2. Securely hold the hexagonal part in pulley center of drive belt auto-tensioner, move in the direction of arrow (loosening direction of tensioner) using Tool.

Tool number : — (J-46535)

WARNING:

Avoid placing hand in a location where pinching may occur if the holding tool accidentally comes off.

CAUTION:

Do not loosen the auto-tensioner pulley bolt. Do not turn it counterclockwise. If turned counterclockwise, the complete auto-tensioner must be replaced as a unit, including pulley.

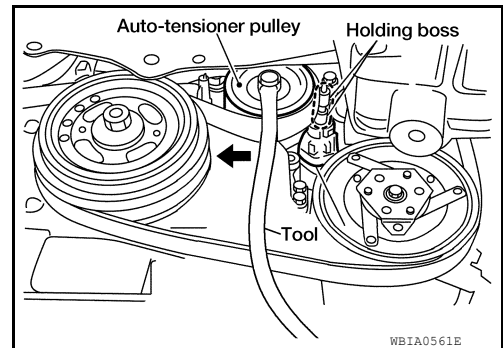

WBIA0561E

DRIVE BELTS

< PERIODIC MAINTENANCE >

[QR25DE]

3. Insert a rod approximately 6 mm (0.24 in) in diameter through the rear of tensioner into retaining boss to lock tensioner pulley.
 - Leave tensioner pulley arm locked until drive belt is installed again.
4. Loosen drive belt from water pump pulley and then remove it from the other pulleys.

INSTALLATION

1. Install the drive belt onto all of the pulleys except for the water pump pulley. Then install the drive belt onto water pump pulley last.
CAUTION:
Confirm belts are completely set on the pulleys.
2. Release tensioner, and apply tension to drive belt.
WARNING:
Avoid placing hand in a location where pinching may occur if the holding tool accidentally comes off.
CAUTION:
Do not loosen the auto-tensioner pulley bolt. Don't turn it counterclockwise. If turned counterclockwise, the complete auto-tensioner must be replaced as a unit, including pulley.
3. Turn crankshaft pulley clockwise several times to equalize tension between each pulley.
4. Confirm tension of drive belt at indicator is within the allowable use range. Refer to [EM-16, "Checking Drive Belts"](#).
5. Install the fender protector side cover (RH). Refer to [EXT-22, "Removal and Installation"](#) (Coupe models) or [EXT-46, "Removal and Installation"](#) (Sedan models).

Removal and Installation of Drive Belt Auto-tensioner

INFOID:000000007420230

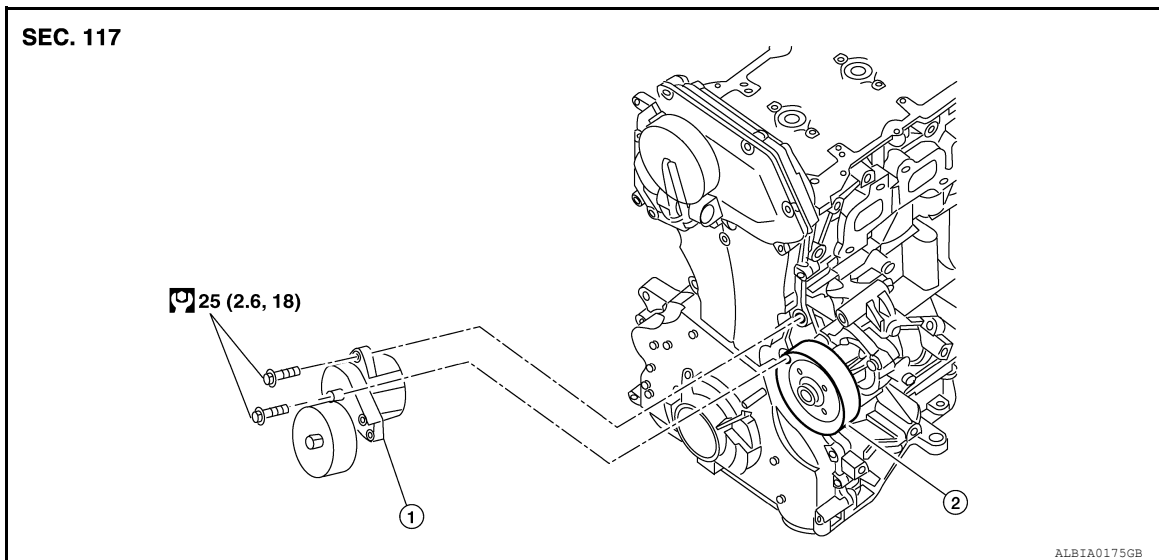

1. Drive belt auto-tensioner

2. Water pump pulley

REMOVAL

CAUTION:

The complete auto-tensioner must be replaced as a unit, including the pulley.

1. Disconnect the battery negative terminal. Refer to [PG-68, "Removal and Installation \(Battery\)"](#) (Coupe models) or [PG-140, "Removal and Installation \(Battery\)"](#) (Sedan models).
2. Remove the RH wheel and tire assembly. Refer to [WT-68, "Adjustment"](#).
3. Remove the fender protector side cover (RH). Refer to [EXT-46, "Removal and Installation"](#).
4. Remove the engine room cover.
5. Remove the drive belt. Refer to [EM-16, "Removal and Installation"](#).
 - Insert a rod approximately 6 mm (0.24 in) in diameter through the rear of tensioner into the retaining boss to lock tensioner pulley.

DRIVE BELTS

[QR25DE]

< PERIODIC MAINTENANCE >

6. Remove power steering reservoir and position aside. Refer to [ST-21, "QR25DE : Component Parts Location"](#).
7. Support the engine with a suitable tool.
8. Remove RH engine mounting bracket, mounting insulator and support bracket. Refer to [EM-74, "Removal and Installation"](#).
9. Remove the drive belt auto-tensioner, with power tool.

CAUTION:

Do not loosen the auto-tensioner pulley bolt. Don't turn it counterclockwise. If turned counterclockwise, the complete auto-tensioner must be replaced as a unit, including pulley.

INSTALLATION

Installation is in the reverse order of removal.

CAUTION:

- **If there is damage greater than peeled paint, replace drive belt auto-tensioner units.**
- **Install the drive belt auto-tensioner carefully so not to damage the water pump pulley.**
- **Do not swap the pulley between the new and old auto-tensioner units.**

AIR CLEANER FILTER

< PERIODIC MAINTENANCE >

[QR25DE]

AIR CLEANER FILTER

Removal and Installation

INFOID:000000007420231

SEC. 118•148•165

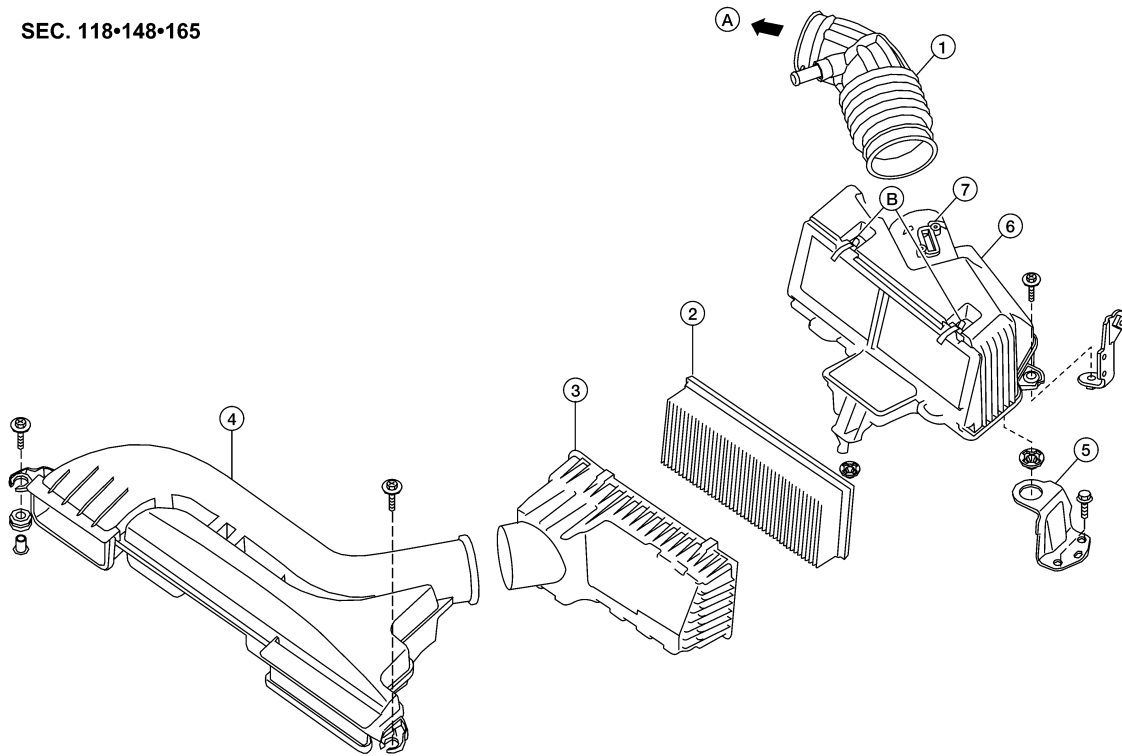

AWBIA05672Z

- | | | |
|-------------------------|--|--------------------------------|
| 1. Air duct hose | 2. Air cleaner filter | 3. Air cleaner case (front) |
| 4. Front air duct | 5. Air cleaner mounting bracket | 6. Air cleaner case (rear) |
| 7. Mass air flow sensor | A. To electric throttle control actuator | B. Air cleaner case side clips |

CHANGING THE AIR CLEANER FILTER

1. Remove the front air duct.
2. Unhook the air cleaner case side clips.
3. Remove the air cleaner case (front).
4. Remove the air cleaner filter.
5. Install a new air cleaner filter.
6. Install the air cleaner case (front).
7. Lock the air cleaner case side clips.
8. Install the front air duct.

CAMSHAFT VALVE CLEARANCE

< PERIODIC MAINTENANCE >

[QR25DE]

CAMSHAFT VALVE CLEARANCE

Camshaft valve clearance

INFOID:000000007420232

- Perform this inspection as follows after removal, installation, or replacement of the camshaft or any valve-related parts, or if there are any unusual engine conditions due to changes in valve clearance over time (starting, idling, and/or noise).

1. Warm up the engine, then stop it.
2. Remove the fender protector side cover (RH). Refer to [EXT-22, "Removal and Installation"](#) (Coupe models) or [EXT-46, "Removal and Installation"](#) (Sedan models).
3. Remove the rocker cover using power tool. Refer to [EM-40, "Removal and Installation"](#).
4. Turn crankshaft pulley in normal direction (clockwise when viewed from front) to align TDC identification mark (without paint mark) with timing indicator.

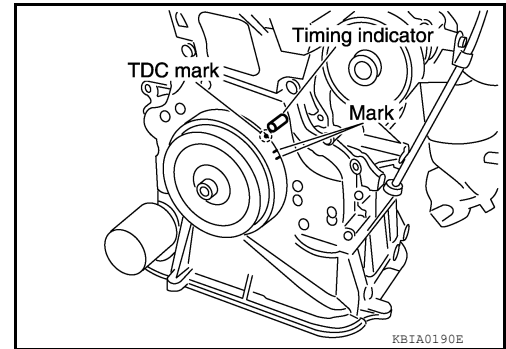

5. At this time, check that the both intake and exhaust cam lobes of No. 1 cylinder face outside.
 - If they do not face outside, turn crankshaft pulley once more.

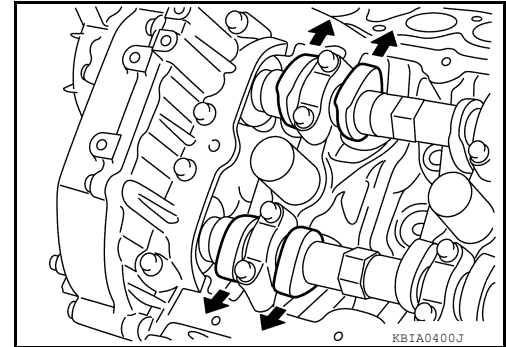

6. Measure valve clearances with a feeler gauge at locations marked "X" in the table below.
 - No.1 cylinder compression TDC.

Cylinder	No.1		No.2		No.3		No.4	
	INT	EXH	INT	EXH	INT	EXH	INT	EXH
Measurable	X	X	X			X		

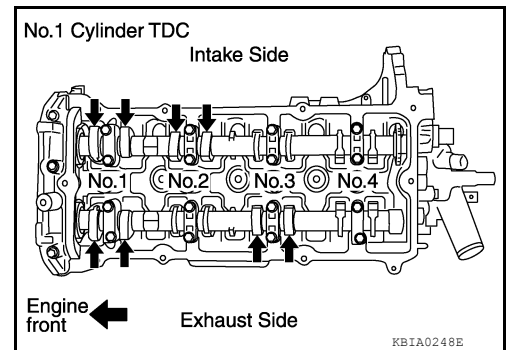

CAMSHAFT VALVE CLEARANCE

[QR25DE]

< PERIODIC MAINTENANCE >

- Use a feeler gauge to measure the clearance between valve and camshaft.

Valve clearance standard:

Cold	Intake	: 0.24 - 0.32 mm (0.009 - 0.013 in)
	Exhaust	: 0.26 - 0.34 mm (0.010 - 0.013 in)
Hot*	Intake	: 0.304 - 0.416 mm (0.012 - 0.016 in)
	Exhaust	: 0.308 - 0.432 mm (0.012 - 0.017 in)

*Approximately 80°C (176°F)

CAUTION:

If inspection was carried out with cold engine, check that values with fully warmed up engine are still within specifications.

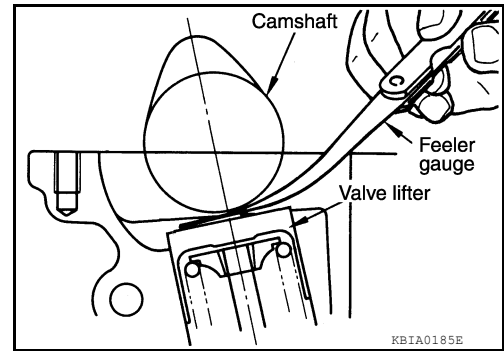

- Turn crankshaft one complete revolution (360°) and align mark on crankshaft pulley with pointer.
- Measure valve clearances with a feeler gauge at locations marked "X" in the table below.
 - No.4 cylinder compression TDC.

Cylinder	No.1		No.2		No.3		No.4		
	Valve	INT	EXH	INT	EXH	INT	EXH	INT	EXH
Measurable				X	X			X	X

- If out of specifications, make necessary adjustment.

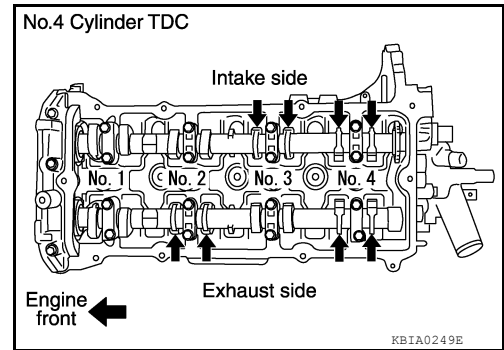

ADJUSTMENT

- Perform adjustment depending on selected head thickness of valve lifter.
- The specified valve lifter thickness is the dimension at normal temperatures. Ignore dimensional differences caused by temperature. Use the specifications for hot engine condition to adjust.

- Remove camshaft. Refer to [EM-42, "Removal and Installation"](#).
- Remove the valve lifters at the locations that are outside the standard.
- Measure the center thickness of the removed valve lifters with a micrometer.

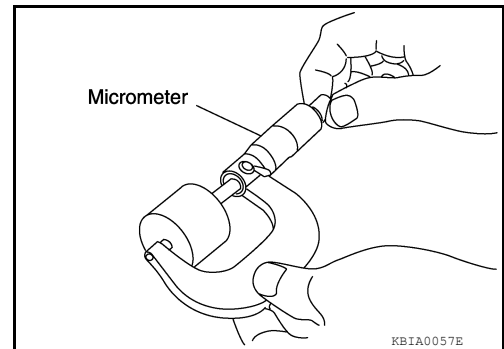

- Use the equation below to calculate valve lifter thickness for replacement.

- Valve lifter thickness calculation.

$$t = t1 + (C1 - C2)$$

t = Thickness of replacement valve lifter.
 t1 = Thickness of removed valve lifter.
 C1 = Measured valve clearance.
 C2 = Standard valve clearance.

CAMSHAFT VALVE CLEARANCE

[QR25DE]

< PERIODIC MAINTENANCE >

- Thickness of a new valve lifter can be identified by stamp marks on the reverse side (inside the cylinder). Stamp mark 696 indicates a thickness of 6.96 mm (0.2740 in). **Available thickness of valve lifter: 26 sizes with a range of 7.88 to 8.38 mm (0.3102 to 0.3299 in), in steps of 0.02 mm (0.0008 in), when assembled at the factory.**

5. Install the selected valve lifter.
6. Install camshaft.
7. Manually turn crankshaft pulley a few turns.
8. Check that valve clearances for cold engine are within specifications, by referring to the specified values.
9. After completing the repair, check valve clearances again with the specifications for warmed engine. Use a feeler gauge to measure the clearance between the valve and camshaft. Make sure the values are within specifications.

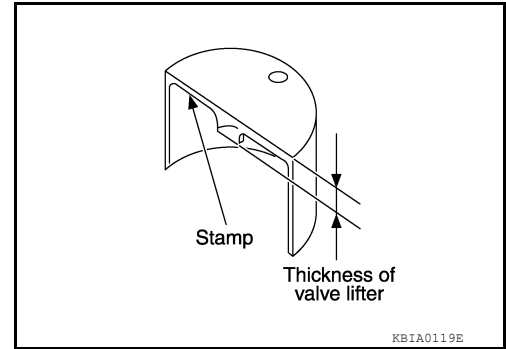

Valve clearance standard:

Cold	Intake	: 0.24 - 0.32 mm (0.009 - 0.013 in)
	Exhaust	: 0.26 - 0.34 mm (0.010 - 0.013 in)
Hot*	Intake	: 0.304 - 0.416 mm (0.012 - 0.016 in)
	Exhaust	: 0.308 - 0.432 mm (0.012 - 0.017 in)

* Approximately 80C° (176°F)

COMPRESSION PRESSURE

Compression pressure

INFOID:000000007420233

CHECKING COMPRESSION PRESSURE

1. Warm up the engine to full operating temperature.
2. Release the fuel pressure. Refer to [EC-322, "Inspection"](#).
3. Remove the ignition coil and spark plug from each cylinder. Refer to [EM-14, "Removal and Installation"](#).
4. Connect engine tachometer (not required in use of CONSULT).
5. Disconnect the fuel injector harness connector to avoid any residual fuel injection during the measurement.
6. Install the compression tester with the adapter into the spark plug hole.

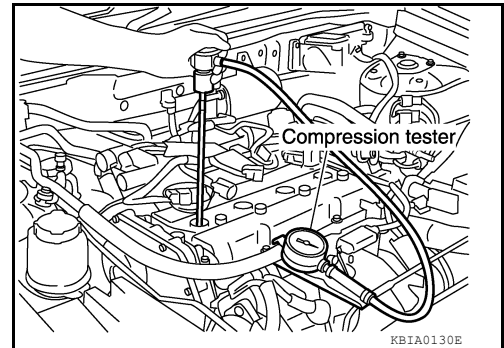

- Use compression tester whose end (rubber portion) is smaller than 20 mm (0.79 in) in diameter. Otherwise, it may be caught by cylinder head during removal.

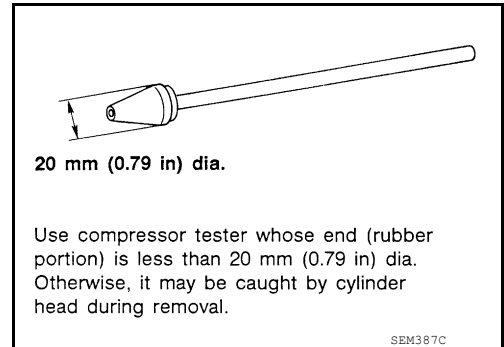

7. With the accelerator pedal fully depressed, turn the ignition switch to the "START" position to crank over the engine. When the gauge pointer stabilizes, read the compression pressure and engine rpm. Perform these steps to check each cylinder.

Unit: kPa (bar, kg/cm², psi) / rpm

Standard	Minimum	Difference limit between cylinders
1,250 (12.50, 12.8, 181.3) / 250	1,060 (10.60, 10.8, 153.7) / 250	100 (1.00, 1.0, 14) / 250

CAUTION:

Always use a fully charged battery to obtain specified engine cranking speed.

- If the engine speed is out of specified rpm range, check the battery. Check engine speed again with a fully charged battery.
- If compression pressure is below minimum value, check valve clearances and parts associated with combustion chamber (valve, valve seat, piston, piston ring, cylinder bore, cylinder head, cylinder head gasket). After the checking, measure compression pressure again.
- If some cylinders have low compression pressure, pour small amount of engine oil into the spark plug hole of the cylinder to re-check it for compression.
- If the added engine oil improves the compression, the piston rings may be worn or damaged. Check the piston rings and replace if necessary.
- If the compression pressure remains at low level despite the addition of engine oil, the valves may be malfunctioning. Check the valves for damage. Replace the valve or valve seat accordingly.

COMPRESSION PRESSURE

< PERIODIC MAINTENANCE >

[QR25DE]

- If two adjacent cylinders have respectively low compression pressure and their compression remains low even after the addition of engine oil, the head gasket is leaking. In such a case, replace the cylinder head gasket.
8. Install spark plug, ignition coil and harness connectors.

REMOVAL AND INSTALLATION

AIR CLEANER AND AIR DUCT

Removal and Installation

INFOID:000000007420234

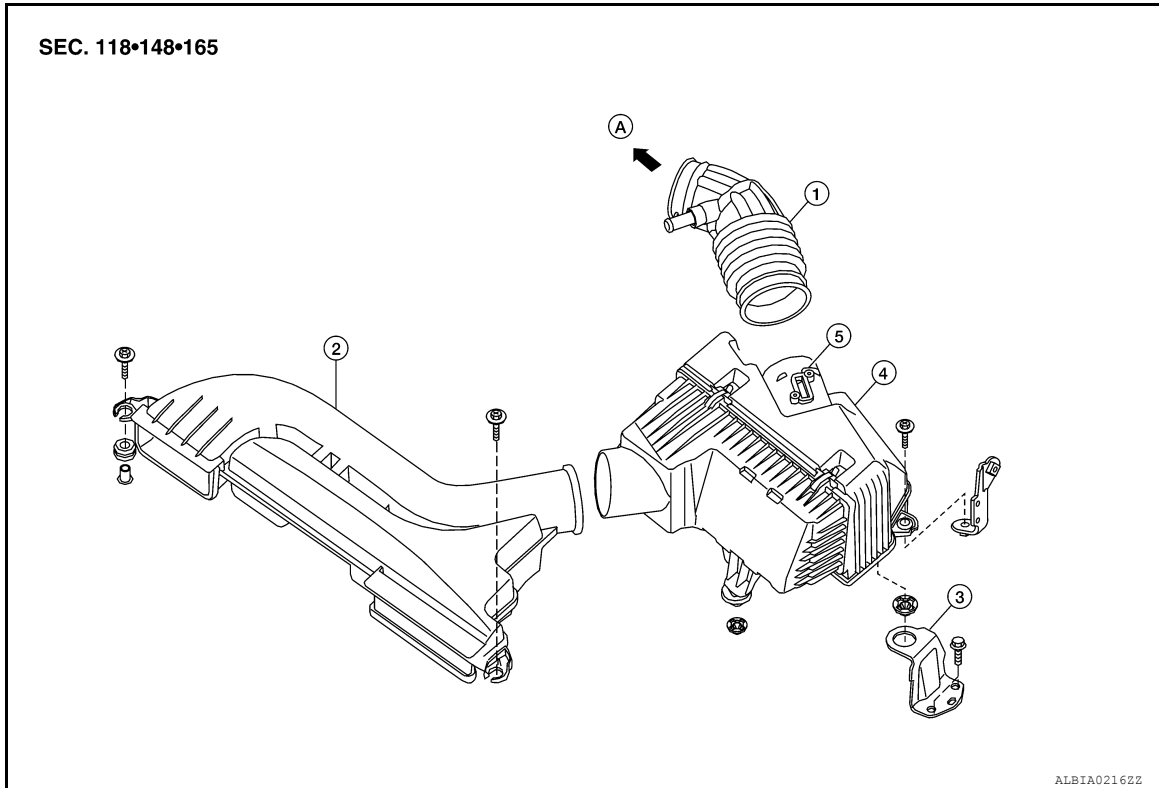

- | | | |
|-------------------------|-------------------------|--|
| 1. Air duct hose | 2. Front air duct | 3. Air cleaner bracket |
| 4. Air cleaner assembly | 5. Mass air flow sensor | A. To electric throttle control actuator |

REMOVAL

1. Remove the engine room cover.
2. Remove front air duct.
3. Disconnect the air duct hose clamps at the electric throttle control actuator and the air cleaner assembly.
4. Disconnect the blow-by hose.
5. Remove air duct hose.
6. Disconnect the transaxle breather hose.
7. Disconnect the mass air flow sensor.
8. Remove mass air flow sensor from air cleaner assembly, as necessary.

CAUTION:

Handle the mass air flow sensor with care:

- Do not shock it.
- Do not disassemble it.
- Do not touch the internal sensor.

9. Remove the air cleaner assembly, as necessary.

INSTALLATION

Installation is in the reverse order of removal.

INTAKE MANIFOLD

< REMOVAL AND INSTALLATION >

[QR25DE]

INTAKE MANIFOLD

Removal and Installation

INFOID:000000007420235

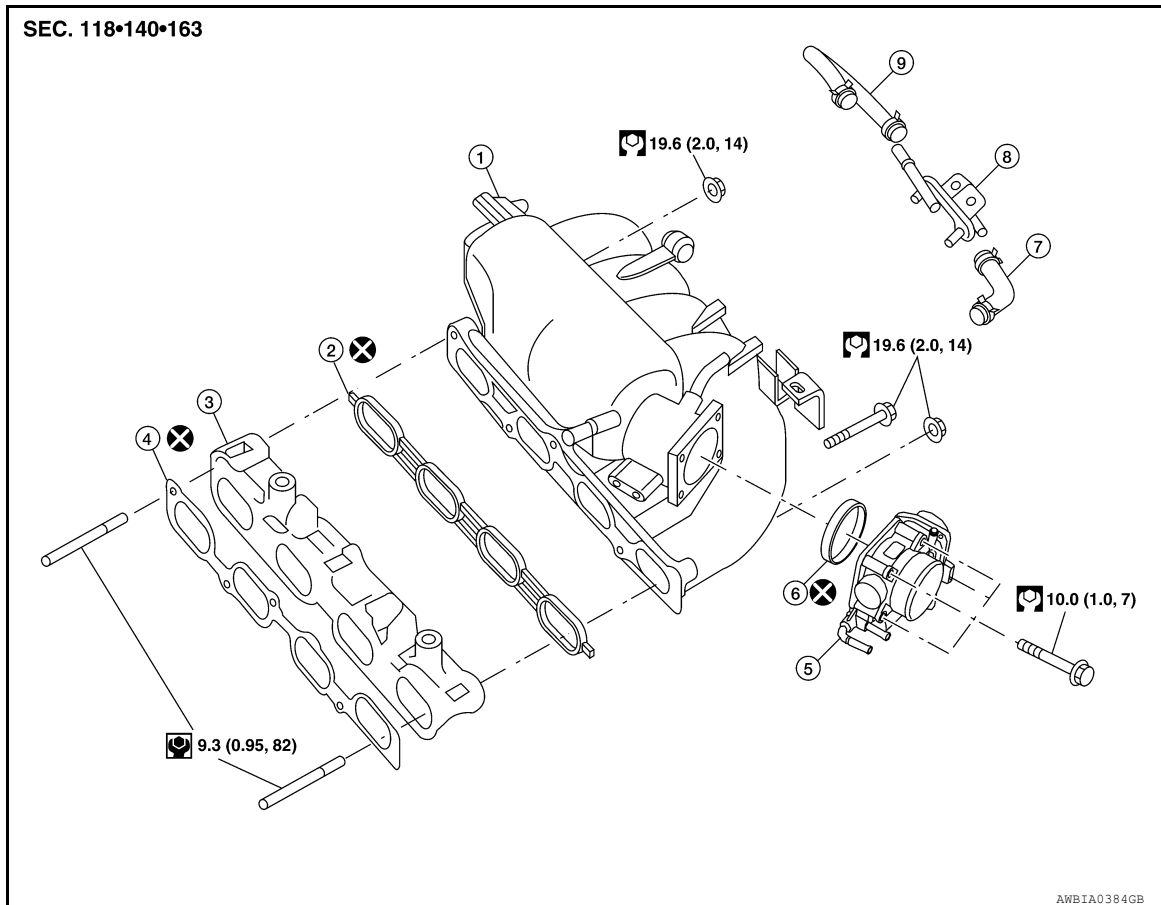

- | | | |
|--------------------|--|----------------------------|
| 1. Intake manifold | 2. Rubber seal | 3. Intake manifold adapter |
| 4. Gasket | 5. Electric throttle control actuator | 6. Rubber seal |
| 7. PCV hose | 8. EVAP canister purge volume control solenoid valve | 9. EVAP hose |

WARNING:

To avoid the danger of being scalded, do not drain the coolant when the engine is hot.

NOTE:

When removing components such as hoses, tubes/lines, etc., cap or plug openings to prevent fluid from spilling.

REMOVAL

1. Remove engine room cover.
2. Release the fuel pressure. Refer to [EC-322, "Inspection"](#).
3. Disconnect battery negative terminal. Refer to [PG-68, "Removal and Installation \(Battery\)"](#) (Coupe models) or [PG-140, "Removal and Installation \(Battery\)"](#) (Sedan models).
4. Remove blow-by hose, air duct hose and front air duct. Refer to [EM-25, "Removal and Installation"](#).
5. Remove cowl top finisher. Refer to [EXT-45, "Removal and Installation"](#).
6. Remove the strut tower bar. Refer to [FSU-14, "Exploded View"](#).
7. Disconnect the following components at the intake side:
 - PCV hose
 - EVAP hose and EVAP canister purge volume control solenoid
 - Electric throttle control actuator
 - Brake booster vacuum hose

INTAKE MANIFOLD

< REMOVAL AND INSTALLATION >

[QR25DE]

8. Disconnect the fuel quick connector on the engine side.
- Using Tool perform the following steps to disconnect the quick connector.

Tool number : 16441 6N210 (J-45488)

- a. Remove quick connector cap.

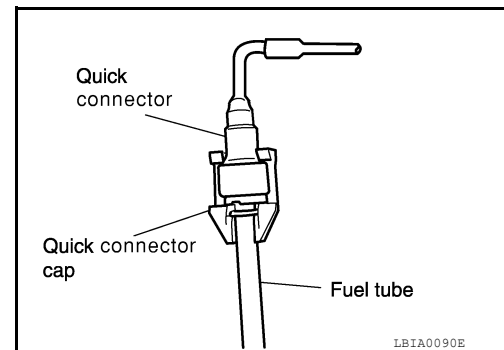

- b. With the sleeve side of Tool facing quick connector, install Tool onto fuel tube.
c. Insert Tool into quick connector until sleeve contacts and goes no further. Hold the Tool on that position.

CAUTION:

Inserting the Tool hard will not disconnect quick connector. Hold Tool where it contacts and goes no further.

- d. Pull the quick connector straight out from the fuel tube.

CAUTION:

- Pull quick connector holding it at the (A) position, as shown.**
- Do not pull with lateral force applied. O-ring inside quick connector may be damaged.**
- Prepare container and cloth beforehand as fuel will leak out.**
- Avoid fire and sparks.**
- Be sure to cover openings of disconnected pipes with plug or plastic bag to avoid fuel leakage and entry of foreign materials.**
- Do not reuse O-ring.**

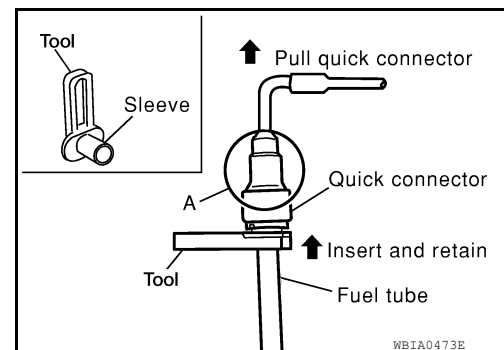

9. When removing fuel hose quick connector at vehicle piping side, perform as follows.

- a. Remove quick connector cap.

- b. Hold the sides of the connector, push in tabs and pull out the tube. (The figure is shown for reference only.)

- If the connector and the tube are stuck together, push and pull several times until they start to move. Then disconnect them by pulling.

CAUTION:

- The tube can be removed when the tabs are completely depressed. Do not twist it more than necessary.**
- Do not use any tools to remove the quick connector.**
- Keep the resin tube away from heat. Be especially careful when welding near the tube.**
- Prevent acid liquid such as battery electrolyte etc. from getting on the resin tube.**
- Do not bend or twist the tube during installation and removal.**
- Do not remove the remaining retainer on tube.**
- When the tube is replaced, also replace the retainer with a new one. Retainer color: Green.**
- To keep clean the connecting portion and to avoid damage and foreign materials, cover them completely with plastic bags or something similar.**

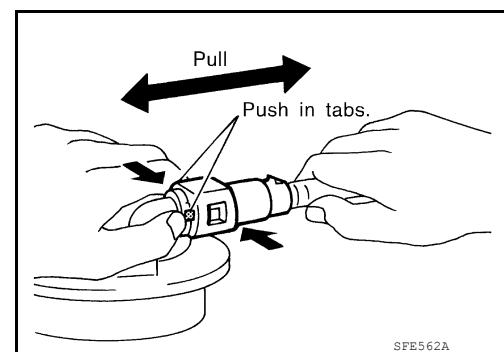

10. Loosen bolts diagonally, and remove the electric throttle control actuator, and position it aside.

CAUTION:

Handle carefully to avoid any damage.

INTAKE MANIFOLD

[QR25DE]

< REMOVAL AND INSTALLATION >

11. Remove the bolts and nuts in the order shown and remove the intake manifold and adaptor assembly and gaskets, using power tools.

CAUTION:

Cover engine openings to avoid entry of foreign materials.

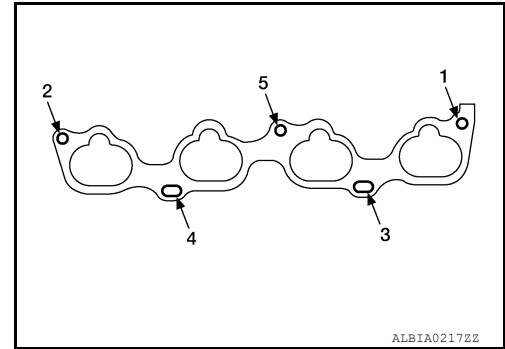

INSPECTION AFTER REMOVAL

Surface Distortion

- Using straightedge and feeler gauge, inspect surface distortion of intake manifold adaptor surfaces and intake manifold surface. Refer to [EM-101, "Standard and Limit"](#). Replace as necessary

INSTALLATION

Installation is in the reverse order of removal. Follow the tightening sequences below.

• Tightening Intake Manifold Bolts and Nuts

- Tighten in numerical order as shown.

CAUTION:

After tightening the five bolts in the order shown, the 1, 6 position designates that the first bolt tightened is to be retightened to specification.

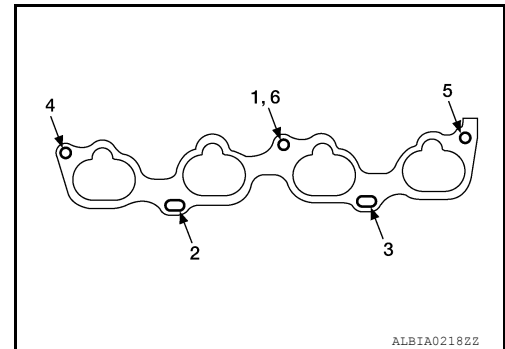

• Installation of Electric Throttle Control Actuator:

- Tighten the bolts of electric throttle control actuator equally and diagonally in several steps.
- After installation perform procedure in "INSPECTION AFTER INSTALLATION".

Connecting Quick Connector On The Fuel Hose (Engine Side)

1. Make sure no foreign substances are deposited in and around the fuel tube and quick connector, and there is no damage to them.
2. Thinly apply new engine oil around the fuel tube tip end.
3. Align center to insert quick connector straight into fuel tube.
 - Insert fuel tube into quick connector until the top spool on fuel tubes is inserted completely and the second level spool is positioned slightly below the quick connector bottom end.

CAUTION:

- Hold at position (A) as shown, when inserting the fuel tube into the quick connector.
- Carefully align to center to avoid inclined insertion to prevent damage to the O-ring inside the quick connector.
- Insert the fuel tube until you hear a "click" sound and actually feel the engagement.
- To avoid misidentification of engagement with a similar sound, be sure to perform the next step.
- Do not reuse O-ring.

4. Before clamping the fuel hose with the hose clamp, pull the quick connector hard by hand, holding at the (1) and (A) positions, as shown. Make sure it is completely engaged (connected) so that it does not come off of the fuel tube.

NOTE:

Recommended pulling force is 50 N (5.1 kg-f, 11.2 lb-f).

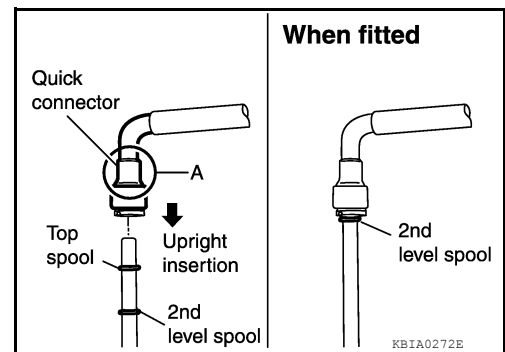

INTAKE MANIFOLD

[QR25DE]

< REMOVAL AND INSTALLATION >

5. Install quick connector cap on quick connector joint.
 - Direct arrow mark on quick connector cap to upper side (fuel hose side).
6. Install fuel hose to hose clamp.

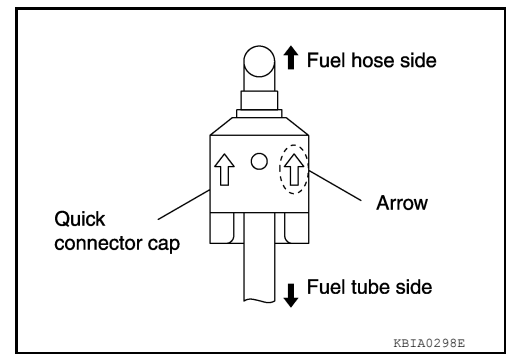

Connecting Quick Connector On The Fuel Hose (Vehicle Piping Side)

1. Make sure no foreign substances are deposited in and around the fuel tube and quick connector, and there is no damage to them.
2. Align center to insert quick connector straight into fuel tube.
 - Insert fuel tube until a click is heard.
 - Install quick connector cap on quick connector joint. Direct arrow mark on quick connector cap upper side.
 - Install fuel hose to hose clamp.

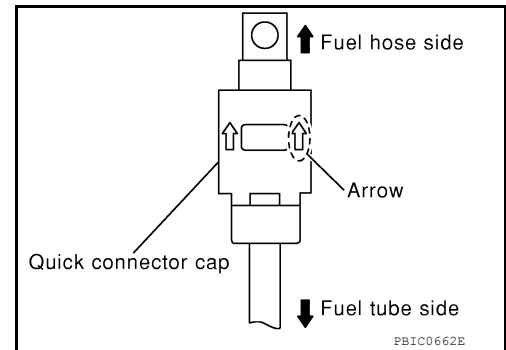

INSPECTION AFTER INSTALLATION

Make sure there is no fuel leakage at connections as follows:

1. Apply fuel pressure to fuel lines by turning ignition switch ON (with engine stopped). Then check for fuel leaks at connections.
2. Start the engine and rev it up and check for fuel leaks at connections.
 - Perform procedures for "Throttle Valve Closed Position Learning" after finishing repairs. Refer to [EC-20, "THROTTLE VALVE CLOSED POSITION LEARNING : Description"](#).
 - If electric throttle control actuator is replaced, perform procedures for "Idle Air Volume Learning" after finishing repairs. Refer to [EC-20, "IDLE AIR VOLUME LEARNING : Description"](#).

WARNING:

Do not touch engine immediately after stopping as engine is extremely hot.

NOTE:

Use mirrors for checking on connections out of the direct line of sight.

EXHAUST MANIFOLD AND THREE WAY CATALYST

< REMOVAL AND INSTALLATION >

[QR25DE]

EXHAUST MANIFOLD AND THREE WAY CATALYST

Removal and Installation

INFOID:000000007420236

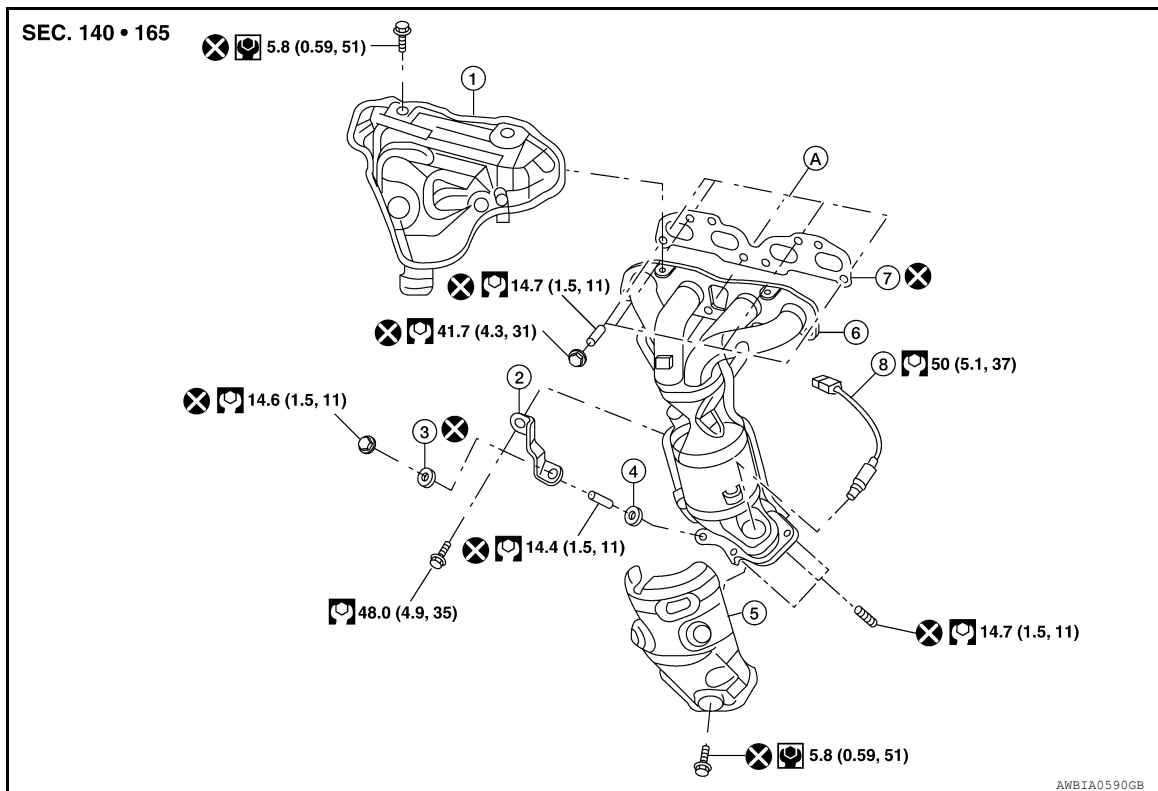

- | | | |
|-----------------------------------|-----------------------------------|---|
| 1. Exhaust manifold cover (upper) | 2. Exhaust manifold stay | 3. Manifold yoke (type B) |
| 4. Manifold yoke (type A) | 5. Exhaust manifold cover (lower) | 6. Exhaust manifold and three way catalyst assembly |
| 7. Exhaust manifold gasket | 8. Air fuel ratio (A/F) sensor 1 | A. To cylinder head |

REMOVAL

1. Disconnect battery negative terminal. Refer to [PG-68, "Removal and Installation \(Battery\)"](#) (Coupe models) or [PG-140, "Removal and Installation \(Battery\)"](#) (Sedan models).
2. Remove the engine undercover. Refer to [EXT-16, "Removal and Installation - Coupe"](#) (Coupe models) or [EXT-40, "Removal and Installation"](#) (Sedan models).
3. Remove front RH wheel and tire. Refer to [WT-68, "Adjustment"](#).
4. Remove fender protector side cover (RH). Refer to [EXT-22, "Removal and Installation"](#) (Coupe models) or [EXT-46, "Removal and Installation"](#) (Sedan models).
5. Remove generator. Refer to [CHG-26, "Removal and Installation"](#).
6. Disconnect the electrical connector of air fuel ratio (A/F) sensor 1, and unhook the harness from the bracket and middle clamp on the cover.
7. Remove the air fuel ratio (A/F) sensor 1 using Tools.

Tool numbers : KV991J0050 (J-44626)
: KV10117100 (J-36471-A)

CAUTION:

- Be careful not to damage air fuel ratio (A/F) sensor.
- Discard any air fuel ratio (A/F) sensor which has been dropped from a height of more than 0.5 m (19.7 in) onto a hard surface such as a concrete floor; replace with a new one.

8. Remove the exhaust manifold cover (lower).
9. Remove the exhaust front tube. Refer to [EX-6, "Exploded View"](#).

EXHAUST MANIFOLD AND THREE WAY CATALYST

< REMOVAL AND INSTALLATION >

[QR25DE]

10. Remove the exhaust manifold cover (upper).
11. Remove the exhaust manifold stay.
12. Loosen the nuts in the numerical order as shown, on the exhaust manifold and three way catalyst assembly.
13. Remove the exhaust manifold and three way catalyst assembly and gasket. Discard the gasket.

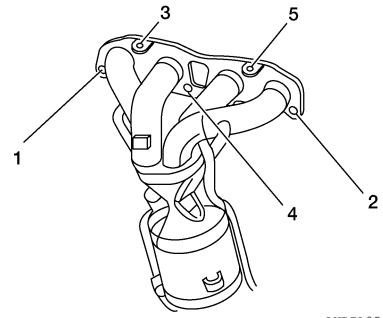

AWBIA05592Z

INSPECTION AFTER REMOVAL

Surface Distortion

- Use a reliable straightedge and feeler gauge to check the flatness of exhaust manifold fitting surface.

Limit : 0.3 mm (0.012 in)

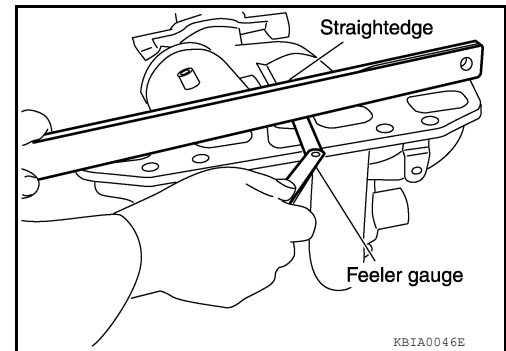

KBIA0046E

INSTALLATION

Installation is in the reverse order of removal.

Tightening Exhaust Manifold Nuts

- Tighten the nuts to specification in the numerical order shown, on the exhaust manifold and three way catalyst assembly.

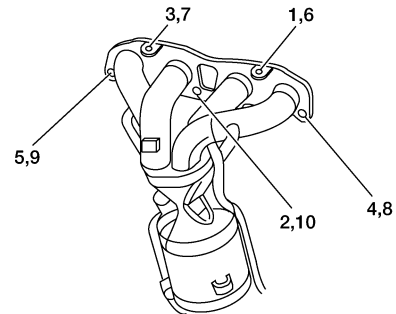

AWBIA05602Z

Installation of Air Fuel Ratio (A/F) Sensor 1

Clean the air fuel ratio (A/F) sensor 1 threads with suitable tool, then apply the anti-seize lubricant to the threads before installing the air fuel ratio (A/F) sensor 1.

Oxygen sensor thread cleaner : J-43897 - 18

Oxygen sensor thread cleaner : J-43897 - 12

CAUTION:

Do not over-tighten the air fuel ratio (A/F) sensor 1. Doing so may cause damage to the air fuel ratio (A/F) sensor 1, resulting in a malfunction and the MIL coming on.

OIL PAN AND OIL STRAINER

< REMOVAL AND INSTALLATION >

[QR25DE]

OIL PAN AND OIL STRAINER

Removal and Installation

INFOID:000000007420237

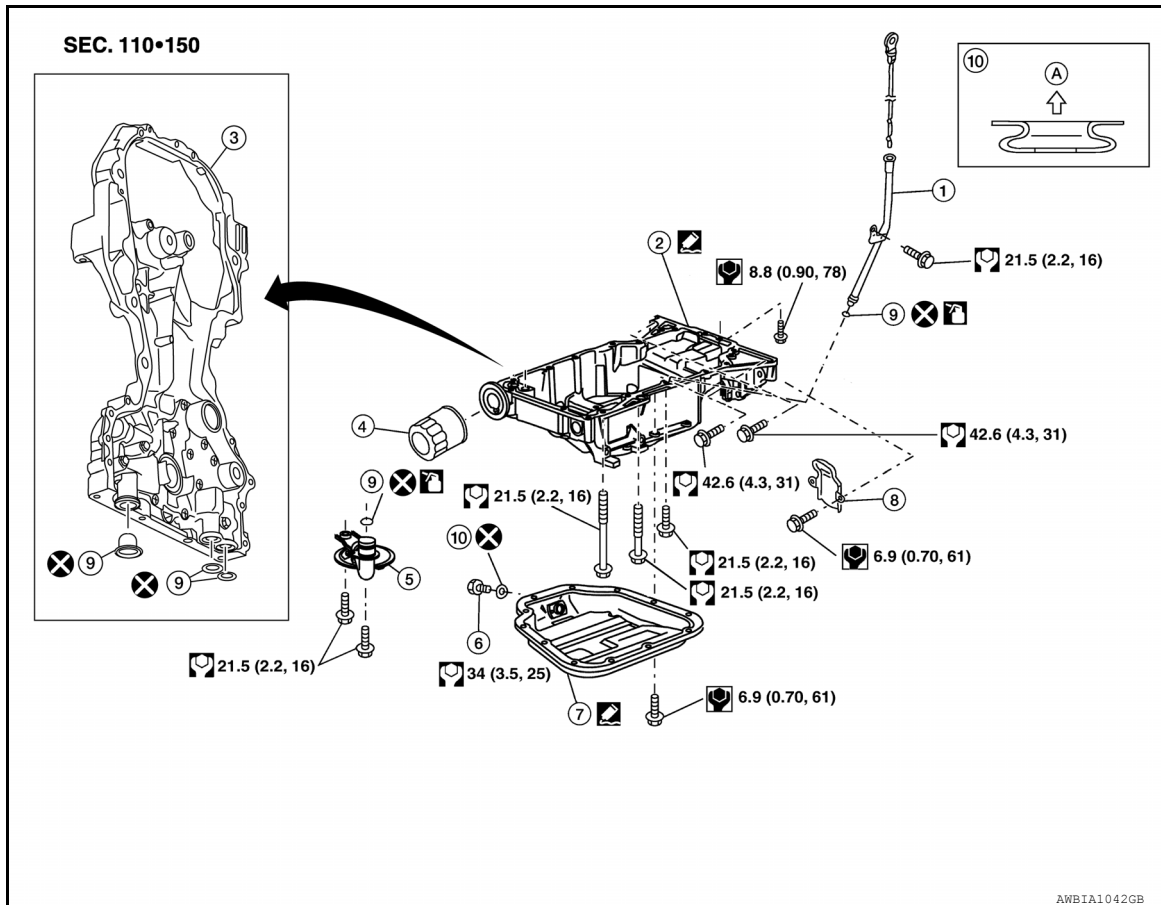

- | | | |
|--------------------------|----------------------|----------------|
| 1. Oil level gauge guide | 2. Oil pan, upper | 3. Front cover |
| 4. Oil filter | 5. Oil strainer | 6. Drain plug |
| 7. Oil pan, lower | 8. Rear plate cover | 9. O-ring |
| 10. Washer | A. To oil pan, lower | |

WARNING:

To avoid the danger of being scalded, do not drain the engine oil when the engine is hot.

NOTE:

When removing components such as hoses, tubes/lines, etc., cap or plug openings to prevent fluid from spilling.

REMOVAL

1. Drain engine oil. Refer to [LU-10, "Changing Engine Oil"](#).
2. Remove the front exhaust tube. Refer to [EX-6, "Exploded View"](#).
3. Remove power steering cooler hose bracket from suspension member.
4. Disconnect the power steering hose and tube from the power steering gear. Refer to [ST-21, "QR25DE : Component Parts Location"](#).
5. Remove oil level gauge guide.
6. Remove the front suspension member for clearance to remove the oil pan. Refer to [FSU-15, "Removal and Installation"](#).
7. Disconnect the A/C compressor electrical connector.
8. Remove the A/C compressor bolts and position the A/C compressor aside. Refer to [HA-31, "Removal and Installation for Compressor - QR25DE Models"](#).

OIL PAN AND OIL STRAINER

[QR25DE]

< REMOVAL AND INSTALLATION >

9. Remove the rear engine mount torque rod bracket. Refer to [EM-74, "Removal and Installation"](#).
10. Remove the center drive shaft bearing bracket from the oil pan, if necessary.
11. Remove the lower oil pan bolts in the order as shown, using power tool.

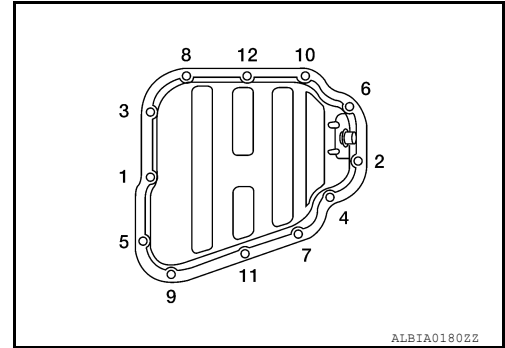

12. Remove the lower oil pan using Tool.

NOTE:

Tap gently to cut sealant around the pan; do not damage the mating surface using Tool.

Tool number : KV10111100 (J-37228)

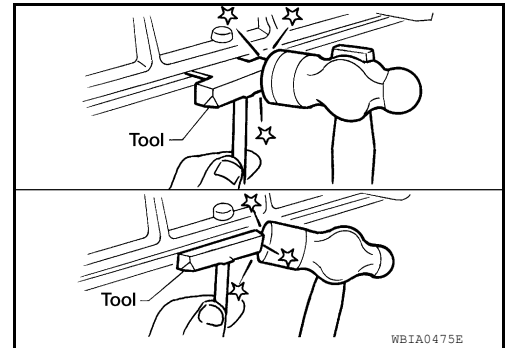

13. Remove the oil strainer.
14. Remove rear plate cover, and four engine-to transaxle bolts, using power tool.
15. Loosen the upper oil pan bolts in the order shown to remove upper oil pan, using power tool.

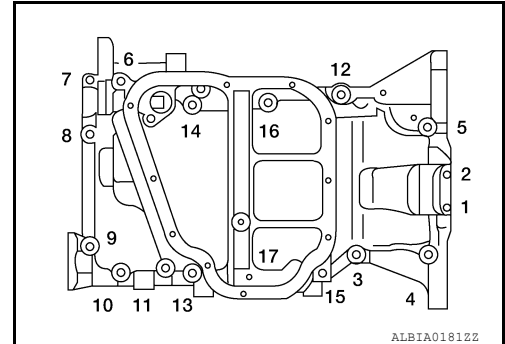

16. Remove upper oil pan using Tool.
 - Remove the three O-rings from the upper oil pan and front cover.

CAUTION:

- Do not reuse O-rings.
- Tap gently to cut sealant around the pan; do not damage the mating surface using Tool.

Tool number : KV10111100 (J-37228)

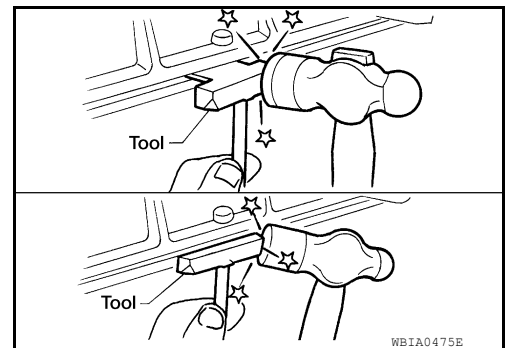

INSPECTION AFTER REMOVAL

- Clean the oil strainer screen to remove any foreign material.

INSTALLATION

Installation is in the reverse order of removal.

OIL PAN AND OIL STRAINER

[QR25DE]

< REMOVAL AND INSTALLATION >

- Apply Genuine Silicone RTV Sealant or equivalent to the upper oil pan at the specified sealant bead diameter (A) as shown. Refer to [GI-15, "Recommended Chemical Products and Sealants"](#).

**Sealant bead diameter (A) : 4.0 - 5.0 mm
(0.157 - 0.197 in)**

CAUTION:

- Install two new O-rings in the upper oil pan and a new O-ring in the front cover.
 - Do not reuse O-rings.
-
- Tighten the upper oil pan bolts in the order as shown.

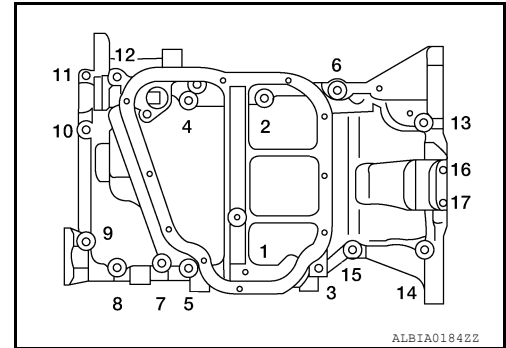
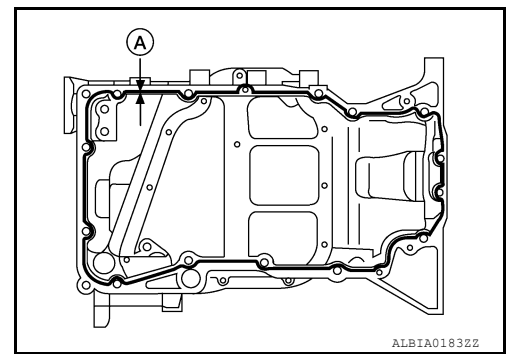

- Apply Genuine Silicone RTV Sealant or equivalent to the lower oil pan at the specified sealant bead diameter (A) as shown. Refer to [GI-15, "Recommended Chemical Products and Sealants"](#).

**Sealant bead diameter (A) : 4.0 - 5.0 mm
(0.157 - 0.197 in)**

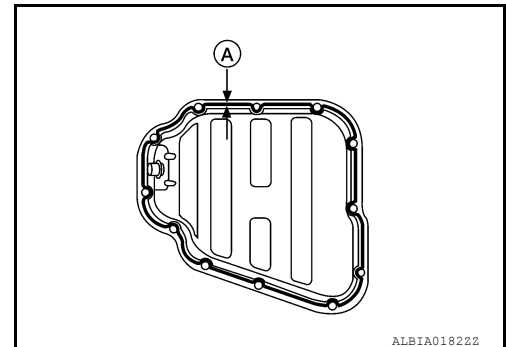

- Tighten the lower oil pan bolts in the numerical order shown.

CAUTION:

Wait at least 30 minutes after the oil pans are installed before filling the engine with oil.

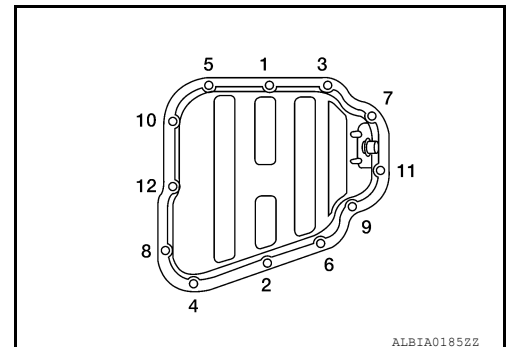

INSPECTION AFTER INSTALLATION

- Before starting engine, check oil/fluid levels including engine coolant and engine oil. If less than required quantity, fill to the specified level. Refer to [MA-12, "Fluids and Lubricants"](#).
- Use procedure below to check for fuel leakage.
- Turn ignition switch ON (with engine stopped). With fuel pressure applied to fuel piping, check for fuel leakage at connection points.
- Start engine. With engine speed increased, check again for fuel leakage at connection points.
- Run engine to check for unusual noise and vibration.

NOTE:

OIL PAN AND OIL STRAINER

< REMOVAL AND INSTALLATION >

[QR25DE]

If hydraulic pressure inside timing chain tensioner drops after removal and installation, slack in the guide may generate a pounding noise during and just after engine start. However, this is normal. Noise will stop after hydraulic pressure rises.

- Warm up engine thoroughly to make sure there is no leakage of fuel, exhaust gas, or any oils/fluids including engine oil and engine coolant.
- Bleed air from passages in lines and hoses, such as in cooling system.
- After cooling down engine, again check oil/fluid levels including engine oil and engine coolant. Refill to specified level, if necessary.
- Summary of the inspection items:

Item		Before starting engine	Engine running	After engine stopped
Engine coolant		Level	Leakage	Level
Engine oil		Level	Leakage	Level
Transmission/ transaxle fluid	A/T and CVT Models	Leakage	Level/Leakage	Leakage
	M/T Models	Level/Leakage	Leakage	Level/Leakage
Other oils and fluids*		Level	Leakage	Level
Fuel		Leakage	Leakage	Leakage
Exhaust gas		—	Leakage	—

*Power steering fluid, brake fluid, etc.

A
EM
C
D
E
F
G
H
I
J
K
L
M
N
O
P

IGNITION COIL

< REMOVAL AND INSTALLATION >

[QR25DE]

IGNITION COIL

Removal and Installation

INFOID:000000007420238

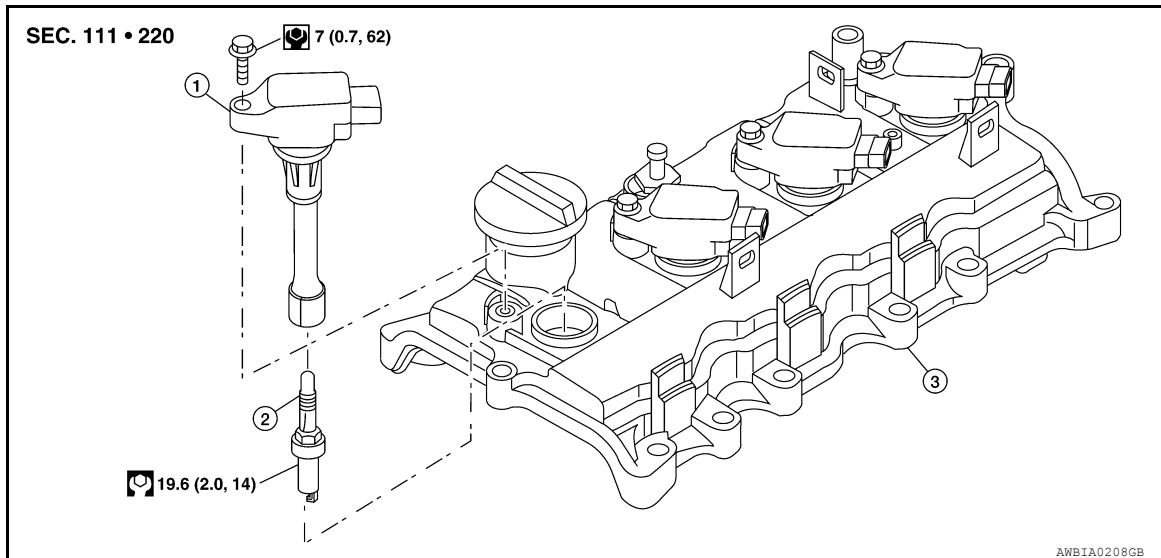

1. Ignition coil

2. Spark plug

3. Rocker cover

REMOVAL

1. Remove the engine room cover.
2. Disconnect the harness connector from the ignition coil.
3. Remove the ignition coil.

CAUTION:

Do not drop or shock it.

INSTALLATION

Installation is in the reverse order of removal.

FUEL INJECTOR AND FUEL TUBE

< REMOVAL AND INSTALLATION >

[QR25DE]

FUEL INJECTOR AND FUEL TUBE

Removal and Installation

INFOID:000000007420239

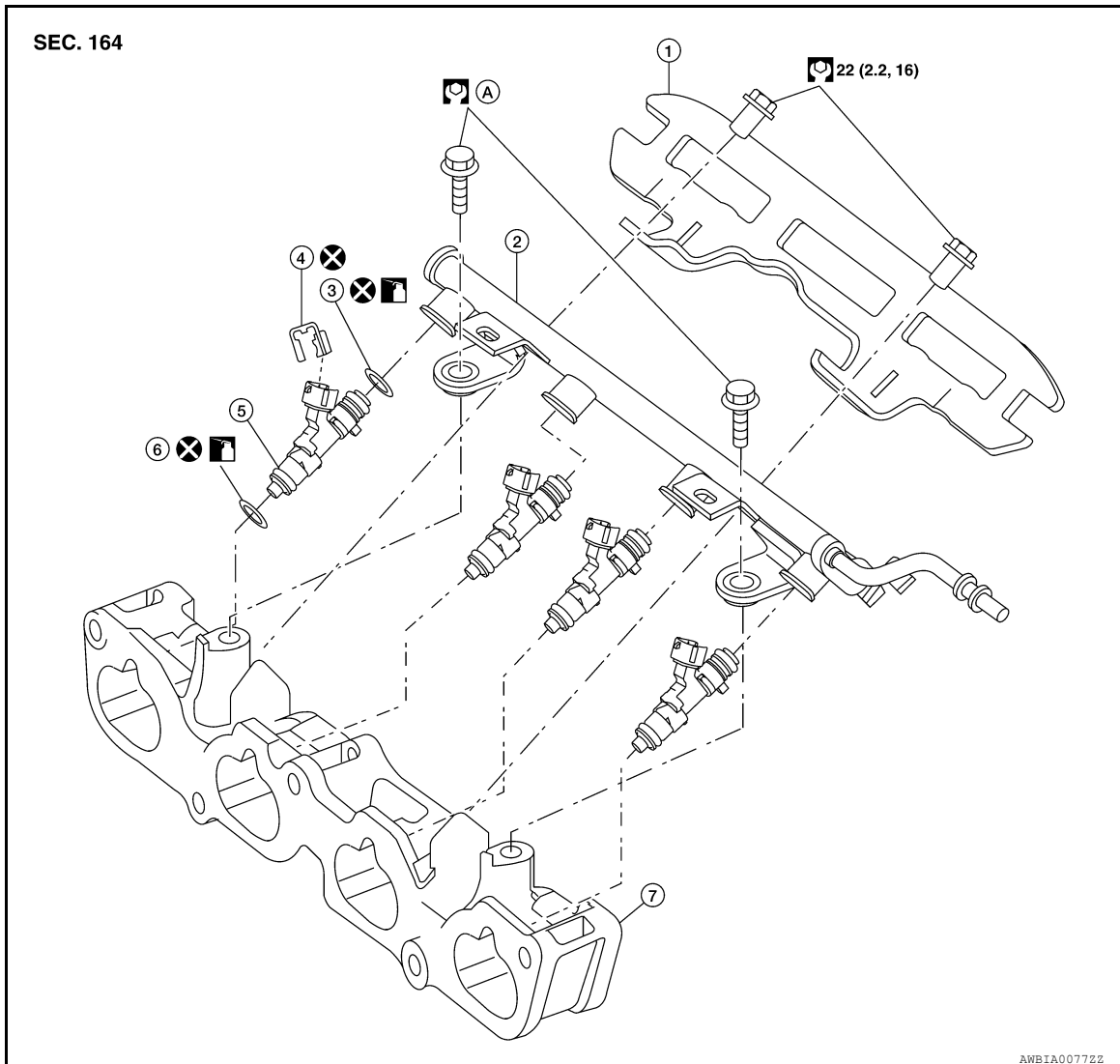

- | | | |
|----------------------------|----------------------------------|-------------------------|
| 1. Fuel tube protector | 2. Fuel tube | 3. Upper O-ring (black) |
| 4. Clip | 5. Fuel injector | 6. Lower O-ring (green) |
| 7. Intake manifold adapter | A. Follow installation procedure | |

CAUTION:

- Apply new engine oil before installing the parts, as shown above.
- Do not remove or disassemble parts unless instructed as shown.

REMOVAL

1. Remove engine room cover.
2. Release the fuel pressure. Refer to [EC-322. "Inspection"](#).
3. Disconnect the battery negative terminal. Refer to [PG-68. "Removal and Installation \(Battery\)"](#) (Coupe models) or [PG-140. "Removal and Installation \(Battery\)"](#) (Sedan models).
4. Remove the front air duct. Refer to [EM-25. "Removal and Installation"](#).
5. Disconnect the fuel hose quick connector at the fuel tube side.

CAUTION:

- Prepare a container and cloth for catching any spilled fuel.
- This operation should be performed in a place that is free from any open flames.

FUEL INJECTOR AND FUEL TUBE

< REMOVAL AND INSTALLATION >

[QR25DE]

- While hoses are disconnected seal their openings with vinyl bag or similar material to prevent foreign material from entering them.
6. Remove the intake manifold. Refer to [EM-26](#).
 7. Disconnect sub-harness for injector at engine front side, and remove it from bracket.
 8. Loosen the bolts in the reverse order shown, then remove fuel tube and fuel injectors as an assembly.
 9. Remove the fuel injectors from the fuel tube.
 - Release the clip and remove the fuel injector.
 - Pull fuel injector straight out of the fuel tube.
- CAUTION:**
- Be careful not to damage the nozzle.
 - Avoid any impact, such as dropping the fuel injector.
 - Do not disassemble or adjust the fuel injector.

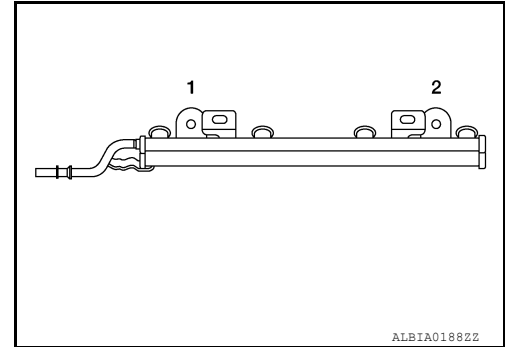

INSTALLATION

1. Install new O-rings on the fuel injector, the fuel side black O-ring and the nozzle side green O-ring.

CAUTION:

 - Do not reuse O-rings.
 - Upper and lower O-rings are different. Be careful not to confuse them.
 - Fuel tube side: black O-ring
 - Nozzle side: green O-ring
 - Lubricate the O-rings lightly with new engine oil.
 - Handle O-rings with bare hands only. Do not wear gloves.
 - Do not clean O-rings with solvent.
 - Make sure that O-ring and its mating part are free of foreign material.
 - Be careful not to scratch it during installation.
 - Do not twist or stretch the O-rings. If the O-rings were stretched while being attached, do not insert into the intake manifold or fuel tube immediately.
2. Install the fuel injector (5) into the fuel tube (1) with the following procedure:
 - Do not reuse the clip (3), replace it with a new one.
 - Insert the new clip (3) into the clip groove (F) on fuel injector (5).
 - Insert the clip (3) so that projection (E) of fuel injector (5) matches notch (C) of the clip (3).
 - Fuel tube side: black O-ring (2)
 - Nozzle side: green O-ring (4)
3. Insert fuel injector (5) into fuel tube (1) with clip (3) attached.
 - Insert it while matching it to the axial center.
 - Insert fuel injector (5) so that projection (A) of fuel tube (1) matches notch (B) of the clip (3).
 - Make sure that fuel tube flange (G) is securely fixed in flange fixing groove (D) on the clip (3).
 - Make sure that installation is complete by checking that fuel injector (5) does not rotate or come off.
4. Install fuel tube assembly.
 - a. Insert the tip of each fuel injector (5) into intake manifold.

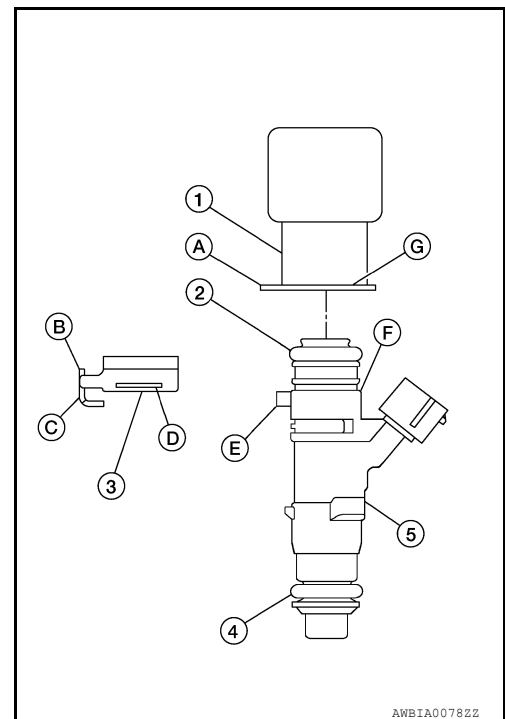

FUEL INJECTOR AND FUEL TUBE

< REMOVAL AND INSTALLATION >

[QR25DE]

- b. Tighten the bolts in two steps in the numerical order as shown.

Fuel tube assembly bolts

Step 1 : 10 N·m (1.0 kg-m, 7 ft-lb)

Step 2 : 22 N·m (2.2 kg-m, 16 ft-lb)

CAUTION:

After properly connecting fuel tube assembly to injector and fuel hose, check connection for fuel leakage.

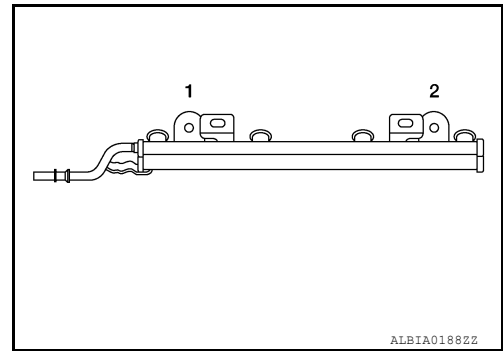

5. Install the intake manifold. Refer to [EM-26](#).
6. Connect the fuel hose quick connector. Refer to [EM-26](#).
7. Installation of the remaining components is in the reverse order of removal.

INSPECTION AFTER INSTALLATION

Make sure there are no fuel leaks.

1. Apply fuel pressure to fuel lines by turning ignition switch ON (with engine stopped). Then check for fuel leaks at connections.
2. Start the engine and rev it up and check for fuel leaks at connections.
 - Perform procedures for "Throttle Valve Closed Position Learning" after finishing repairs. Refer to [EC-20, "THROTTLE VALVE CLOSED POSITION LEARNING : Description"](#).
 - If electric throttle control actuator is replaced, perform procedures for "Idle Air Volume Learning" after finishing repairs. Refer to [EC-20, "IDLE AIR VOLUME LEARNING : Description"](#).

WARNING:

Do not touch engine immediately after stopping as engine is extremely hot.

NOTE:

Use mirrors for checking on connections out of the direct line of sight.

ROCKER COVER

< REMOVAL AND INSTALLATION >

[QR25DE]

ROCKER COVER

Removal and Installation

INFOID:000000007420240

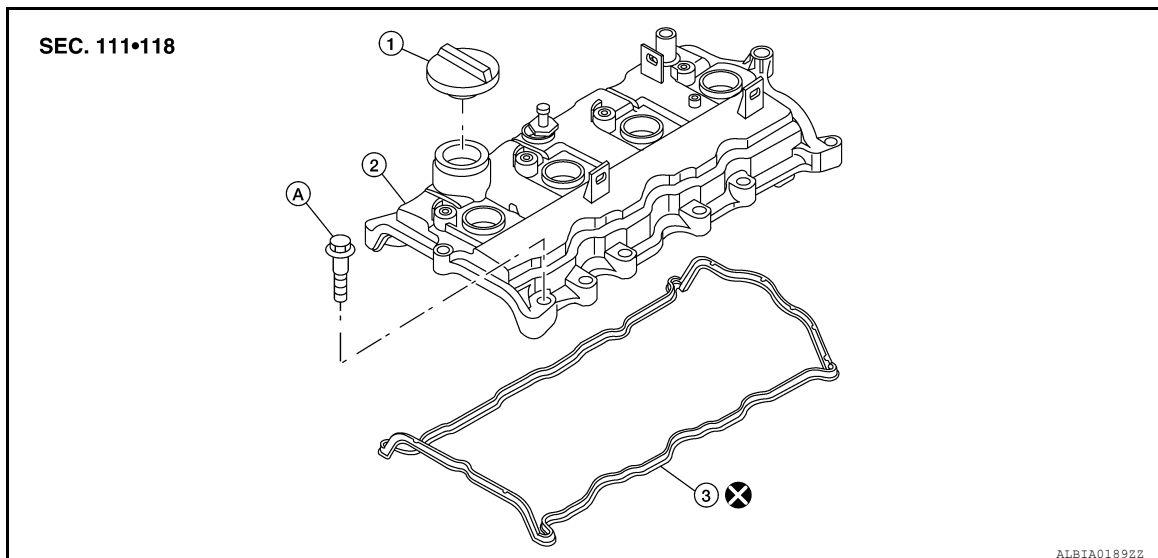

1. Oil filler cap
 2. Rocker cover
 3. Rocker cover gasket
- A. Follow installation for tightening steps

REMOVAL

1. Disconnect the battery negative terminal. Refer to [PG-68, "Removal and Installation \(Battery\)"](#) (Coupe models) or [PG-140, "Removal and Installation \(Battery\)"](#) (Sedan models).
2. Remove the engine room cover.
3. Remove the front air duct. Refer to [EM-25, "Removal and Installation"](#).
4. Remove the blow-by hose.
5. Remove the power steering fluid reservoir and position aside.
6. Remove the RH engine mount torque rod. Refer to [EM-74, "Removal and Installation"](#).
7. Use a suitable tool to support the engine assembly.
8. Remove the RH engine support bracket. Refer to [EM-74, "Removal and Installation"](#).
9. Remove the RH engine bracket. Refer to [EM-74, "Removal and Installation"](#).
10. Disconnect the PCV hose.
11. Remove the ignition coils. Refer to [EM-36, "Removal and Installation"](#).
12. Disconnect the fuel injectors and position the fuel injector harness aside.
13. Loosen the bolts in the numerical order as shown using power tool.
14. Remove the rocker cover and the rocker cover gasket. Discard the rocker cover gasket.
CAUTION:
Do not reuse the rocker cover gasket.
15. Remove the oil filler cap if necessary, to transfer to the new rocker cover.

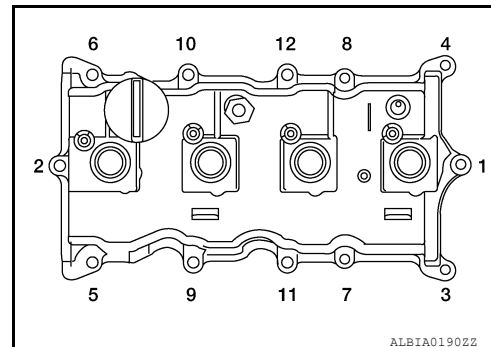

INSTALLATION

ROCKER COVER

[QR25DE]

< REMOVAL AND INSTALLATION >

1. Apply RTV Silicone Sealant to the joint part of the cylinder head and camshaft bracket using the following the steps:
 - Use Genuine Silicone RTV Sealant, or equivalent. Refer to [GL-15. "Recommended Chemical Products and Sealants"](#).
- a. Follow illustration (a) to apply sealant to joint part of No.1 camshaft bracket and cylinder head.
- b. Follow illustration (b) to apply sealant in a 90° degree angle to the illustration (a).

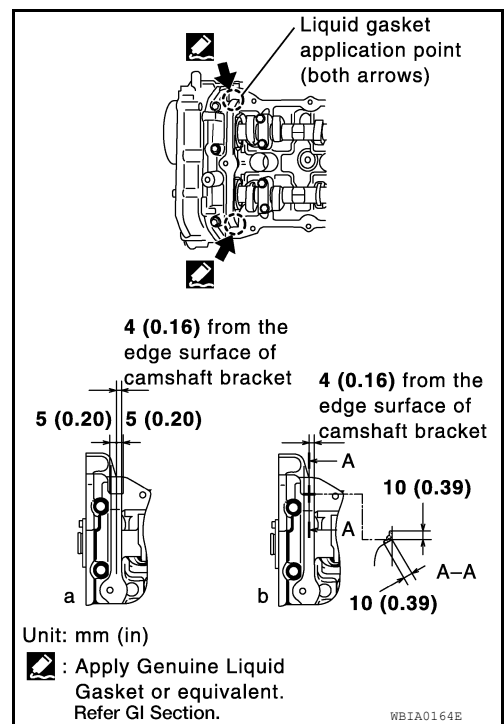

2. Install the rocker cover and the new rocker cover gasket.
 - The rocker cover gasket must be securely installed in the groove in the rocker cover.
3. Tighten the rocker cover bolts in two steps, in the numerical order as shown.

- Step 1 : 1.96 N·m (0.20 kg-m, 17 in-lb)**
- Step 2 : 8.33 N·m (0.85 kg-m, 74 in-lb)**

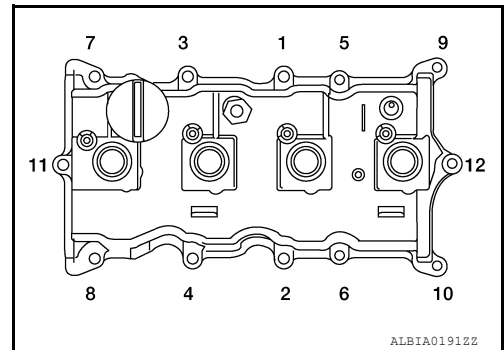

4. Installation of the remaining components is in the reverse order of removal.

CAMSHAFT

< REMOVAL AND INSTALLATION >

[QR25DE]

CAMSHAFT

Removal and Installation

INFOID:000000007420241

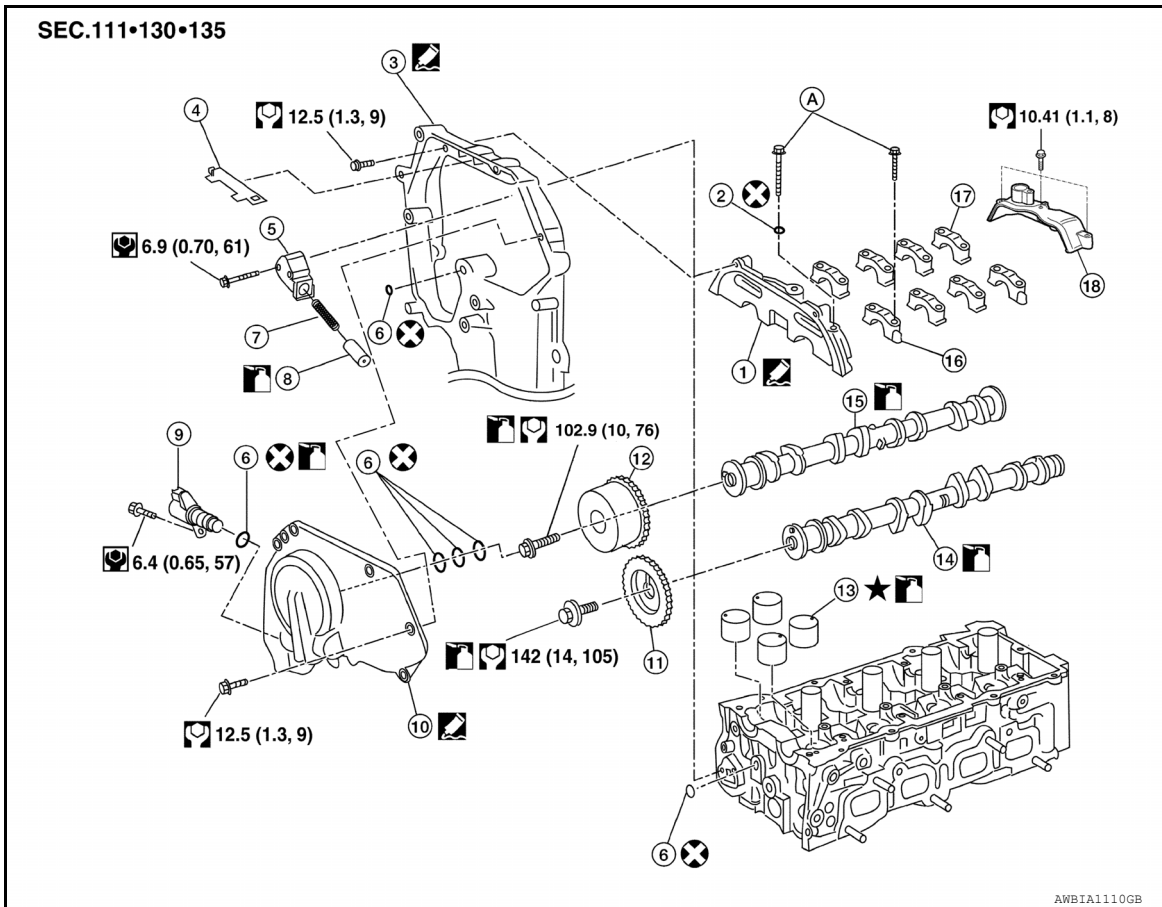

- | | | |
|---|-----------------------------|-------------------------------|
| 1. Camshaft bracket (No.1) | 2. Washer | 3. Front cover (partial view) |
| 4. Chain guide | 5. Chain tensioner | 6. O-ring(s) |
| 7. Chain tensioner spring | 8. Chain tensioner plunger | 9. IVT control solenoid valve |
| 10. IVT control cover | 11. Camshaft sprocket (EXH) | 12. Camshaft sprocket (INT) |
| 13. Valve lifter | 14. Camshaft (EXH) | 15. Camshaft (INT) |
| 16. Camshaft brackets (EXH) | 17. Camshaft brackets (INT) | 18. Camshaft sensor bracket |
| A. Follow installation for tightening steps | | |

REMOVAL

1. Remove the rocker cover. Refer to [EM-40, "Removal and Installation"](#).
2. Disconnect variable timing control solenoid and camshaft sensor harness connectors.
3. Remove camshaft sensor.
4. Remove camshaft sensor bracket.

CAMSHAFT

< REMOVAL AND INSTALLATION >

[QR25DE]

5. Loosen the IVT control cover bolts in the order as shown.

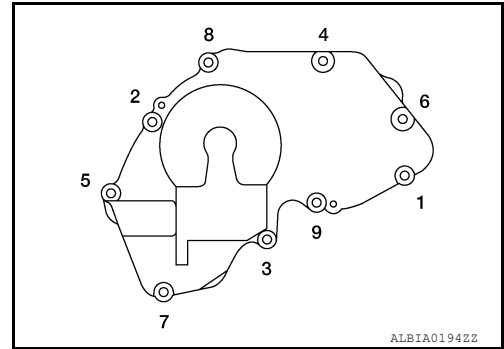

- Remove the IVT control cover by cutting the sealant using Tool.

Tool number : KV10111100 (J-37228)

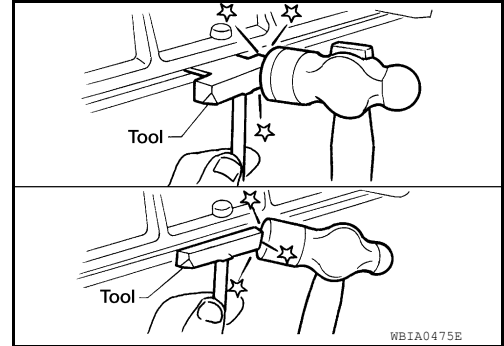

6. Set the No.1 cylinder at TDC on its compression stroke with the following procedure:
- Remove the fender protector side cover (RH). Refer to [EXT-22 "Removal and Installation"](#) (Coupe models) or [EXT-46 "Removal and Installation"](#) (Sedan models).
 - Rotate crankshaft pulley clockwise, and align mating marks for TDC with timing indicator on front cover, as shown.

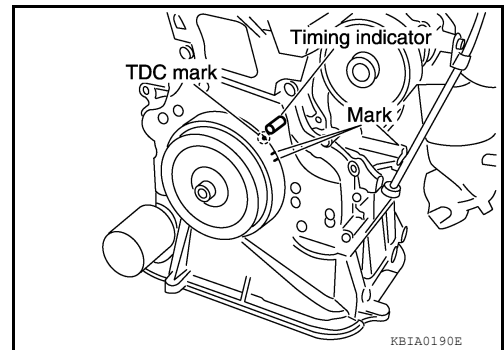

- At the same time, make sure that the mating marks on camshaft sprockets are lined up with the blue links in the timing chain, as shown.
 - If not, rotate crankshaft pulley one more turn to line up the mating marks to the blue links, as shown.

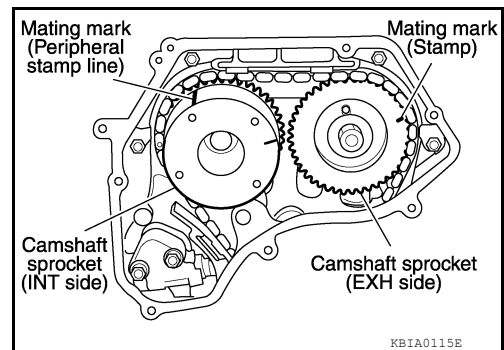

7. Remove camshaft sprockets with the following procedure.

CAUTION:

Do not rotate the crankshaft or camshaft while the timing chain is removed. It causes interference between valve and piston.

NOTE:

Chain tension holding work is not necessary. Crankshaft sprocket and timing chain do not disconnect structurally while front cover is attached.

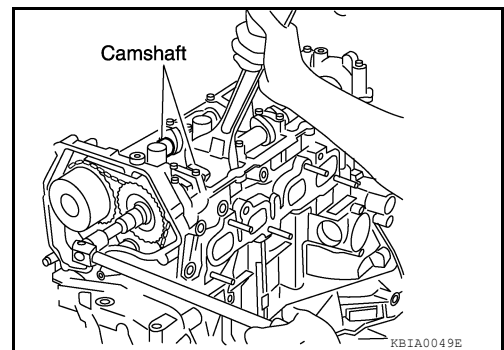

CAMSHAFT

[QR25DE]

< REMOVAL AND INSTALLATION >

- Line up the mating marks on camshaft sprockets with the blue links in the timing chain, and paint an indelible mating mark on the sprocket and timing chain link plate.
- Push in the tensioner plunger and hold. Insert a stopper pin into the hole on tensioner body to hold the chain tensioner. Remove the timing chain tensioner.
 - Use a wire with 0.5 mm (0.02 in) diameter for a stopper pin.
- Secure the hexagonal part of camshaft with a suitable tool. Loosen the camshaft sprocket bolts and remove the camshaft sprockets.

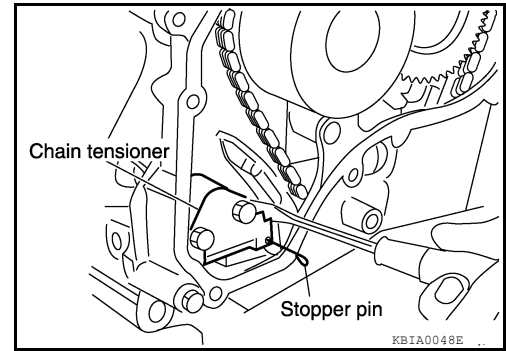

- Pull the timing chain guide out between the camshaft sprockets through front cover.
- Loosen the camshaft bracket bolts in the order as shown, and remove the camshaft brackets and camshafts.
 - Remove No.1 camshaft bracket by slightly tapping it with a rubber mallet.
- Remove the valve lifters.
 - Check mounting positions, and set them aside in the order removed.

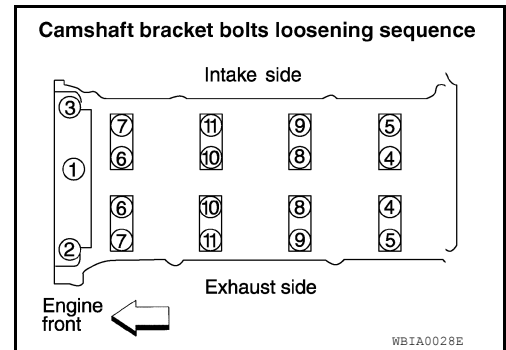

INSPECTION AFTER REMOVAL

Camshaft Runout

- Put the camshaft on a V-block supporting the No.2 and No.5 journals.
- Set the dial gauge vertically on the No.3 journal.
- Turn camshaft in one direction by hand, and measure the camshaft runout on the dial gauge total indicator reading.

Standard : Less than 0.04 mm (0.0016 in)

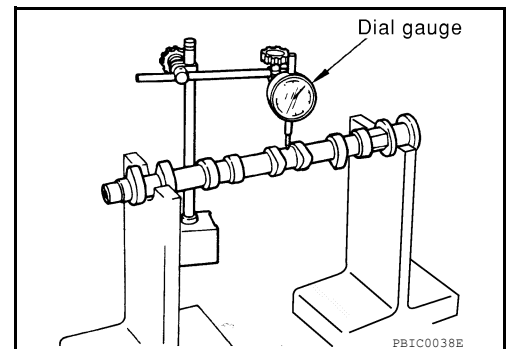

Camshaft Cam Height

- Measure the camshaft cam height.

Standard intake cam height : 44.815 - 45.005 mm (1.7644 - 1.7718 in)

Standard exhaust cam height : 43.975 - 44.165 mm (1.7313 - 1.7388 in)

- If wear is beyond the limit, replace the camshaft.

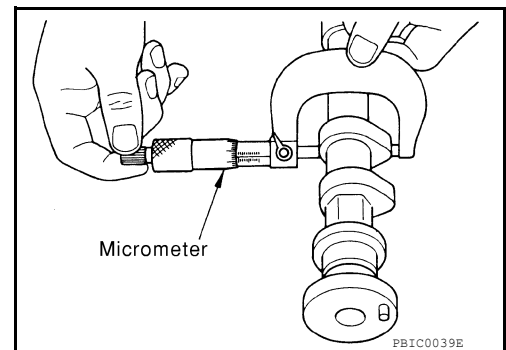

Camshaft Journal Clearance

Outer Diameter of Camshaft Journal

CAMSHAFT

< REMOVAL AND INSTALLATION >

[QR25DE]

- Measure the outer diameter of the camshaft journal.

Standard No. 1 outer diameter	: 27.935 - 27.955 mm (1.0998 - 1.1006 in)
Standard No. 2, 3, 4, 5, outer diameter	: 23.435 - 23.455 mm (0.9226 - 0.9234 in)

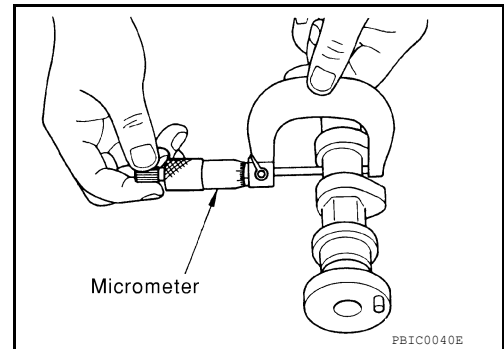

Inner Diameter of Camshaft Bracket

- Tighten the camshaft bracket bolts to the specified torque following the tightening pattern as shown.

Step 1 (bolts 9 - 11)	: 1.96 N·m (0.2 kg-m, 17 in-lb)
Step 2 (bolts 1 - 8)	: 1.96 N·m (0.2 kg-m, 17 in-lb)
Step 3 (bolts 1 - 11)	: 5.88 N·m (0.6 kg-m, 52 in-lb)
Step 4 (bolts 1 - 11)	: 10.4 N·m (1.02 kg-m, 92 in-lb)

CAUTION:

After tightening camshaft bracket bolts, be sure to wipe off excessive sealant from the parts listed below.

- Mating surface of rocker cover.
- Mating surface of front cover, when installed without the front cover.

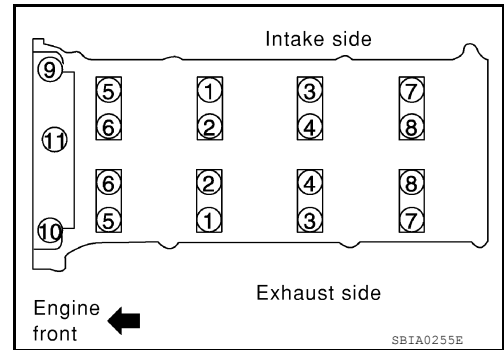

- Using inside micrometer, measure inner diameter of camshaft bracket.

Standard No. 1	: 28.000 - 28.021 mm (1.1024 - 1.1032 in)
Standard No. 2, 3, 4, 5	: 23.500 - 23.521 mm (0.9252 - 0.9260 in)

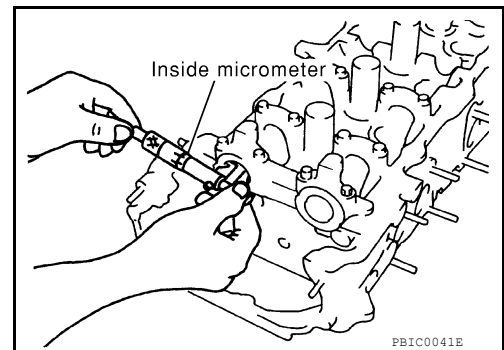

Calculation of Camshaft Journal Clearance

- (Journal clearance) = (inner diameter of camshaft bracket) – (outer diameter of camshaft journal)

Standard	: 0.045 - 0.086 mm (0.0018 - 0.0034 in)
-----------------	--

- When out of the specified range above, replace either or both the camshaft and the cylinder head assembly.

NOTE:

Inner diameter of the camshaft bracket is manufactured together with the cylinder head. If the camshaft bracket is out of specification, replace the whole cylinder head assembly.

Camshaft End Play

CAMSHAFT

[QR25DE]

< REMOVAL AND INSTALLATION >

1. Install a dial gauge in the thrust direction on the front end of the camshaft. Measure the end play with the dial gauge while moving the camshaft forward and backward (in direction to axis).

Standard end play : 0.115 - 0.188 mm (0.0045 - 0.0074 in)

2. If out of the specified range, replace with new camshaft and measure again.
3. If out of the specified range again, replace with new cylinder head assembly.

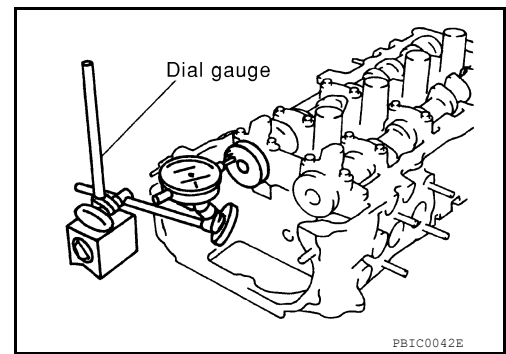

Camshaft Sprocket Runout

1. Install the camshaft in the cylinder head.
2. Install the camshaft sprocket on the camshaft.
3. Measure camshaft sprocket runout while turning the camshaft by hand.

Runout : Less than 0.15 mm (0.0059 in)

4. If it exceeds the specification, replace camshaft sprocket.

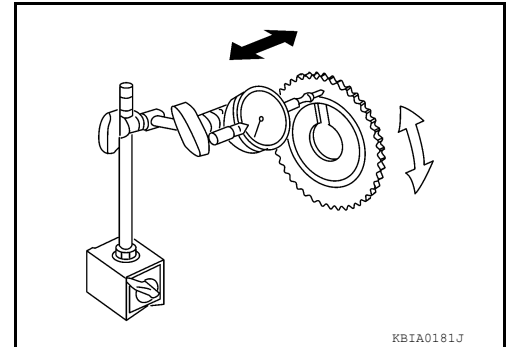

Valve Lifter

- Check if the surface of the valve lifter has any excessive wear or cracks, replace as necessary.

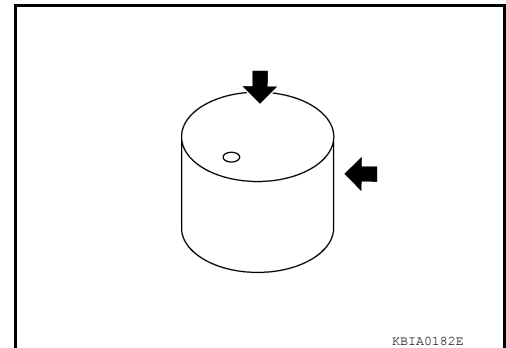

Valve Lifter Clearance

Outer Diameter of Valve Lifter

- Measure the outer diameter of the valve lifter.

Valve lifter outer diameter : 33.977- 33.987 mm (1.3377 - 1.3381 in)

- If out of the specified range, replace the valve lifter.

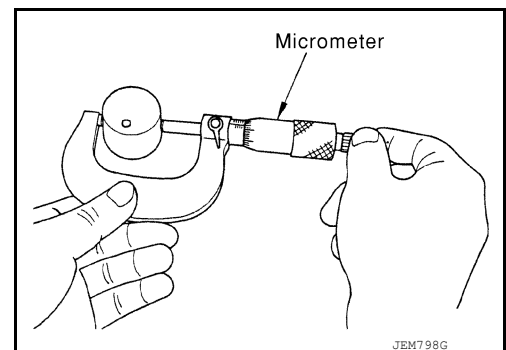

CAMSHAFT

< REMOVAL AND INSTALLATION >

[QR25DE]

Valve Lifter Bore Inner Diameter

- Using inside micrometer, measure diameter of valve lifter bore of cylinder head.

Standard : 34.000 - 34.021 mm (1.3386 - 1.3394 in)

- If out of the specified range, replace the cylinder head assembly.

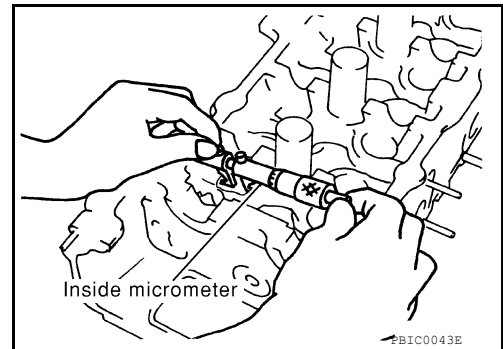

Calculation of Valve Lifter Clearance

- (Valve lifter clearance) = (hole diameter for valve lifter) – (outer diameter of valve lifter)

Standard : 0.013 - 0.044 mm (0.0005 - 0.0017 in)

- If out of specified range, replace either or both valve lifter and cylinder head assembly.

INSTALLATION

- Install the valve lifter.
 - Install them in the same position from which they were removed.
- Install the camshafts.
 - The distinction between the intake and exhaust camshafts is in a difference of shapes of the back end:
 - A: Exhaust
 - B: Intake Signal plate for the camshaft position sensor (PHASE)

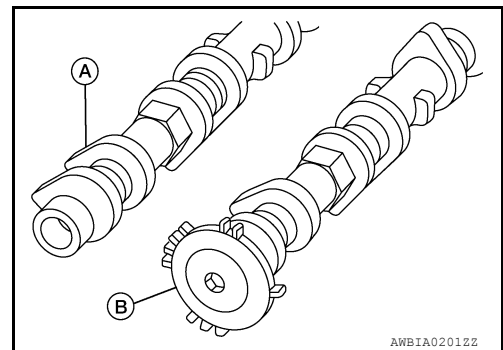

- Install camshafts so that the dowel pins on the front side are positioned as shown.

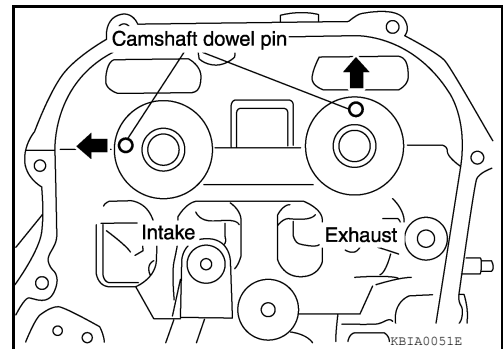

- Install camshaft brackets.
 - Install by referring to identification mark on upper surface mark.
 - Install so that identification mark can be correctly read when viewed from the exhaust side.

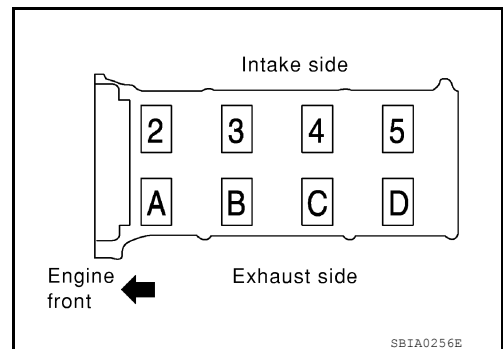

CAMSHAFT

[QR25DE]

< REMOVAL AND INSTALLATION >

- Install No. 1 camshaft bracket as follows.
- Apply sealant to No.1 camshaft bracket as shown.
- Use **Genuine Silicone RTV Sealant, or equivalent. Refer to GI-15, "Recommended Chemical Products and Sealants".**

CAUTION:

- After installation, be sure to wipe off any excessive sealant leaking from part (A) (both on right and left sides).

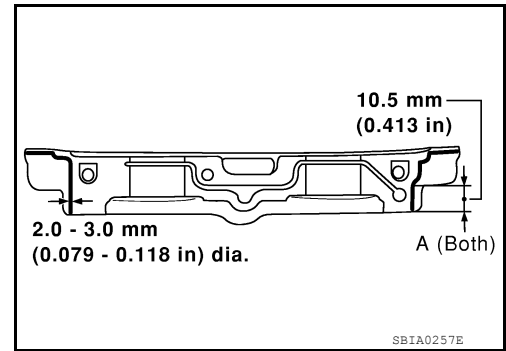

- Apply sealant to camshaft bracket contact surface on the front cover backside.

Dimension (A) : 3.9 mm (0.154 in)

- Apply sealant to the outside of bolt hole on front cover.

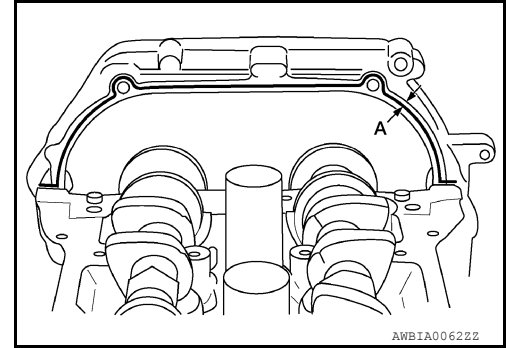

- Position the No.1 camshaft bracket near the mounting position, and install it without disturbing the sealant applied to the surfaces.

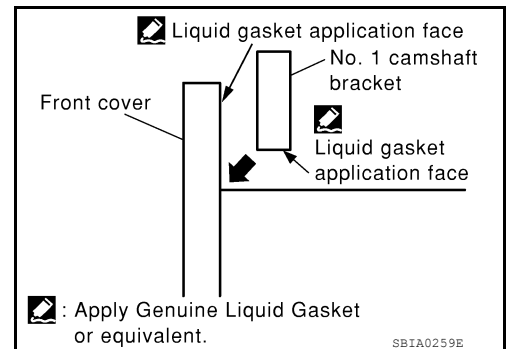

4. Tighten camshaft bracket bolts in four steps in the order as shown.

Step 1 (bolts 9 - 11) : 1.96 N·m (0.2 kg-m, 17 in-lb)

Step 2 (bolts 1 - 8) : 1.96 N·m (0.2 kg-m, 17 in-lb)

Step 3 (bolts 1 - 11) : 5.88 N·m (0.6 kg-m, 52 in-lb)

Step 4 (bolts 1 - 11) : 10.4 N·m (1.02 kg-m, 92 in-lb)

CAUTION:

After tightening camshaft bracket bolts, be sure to wipe off excessive sealant from the parts listed below.

- Mating surface of rocker cover.
- Mating surface of front cover, when installed without the front cover.

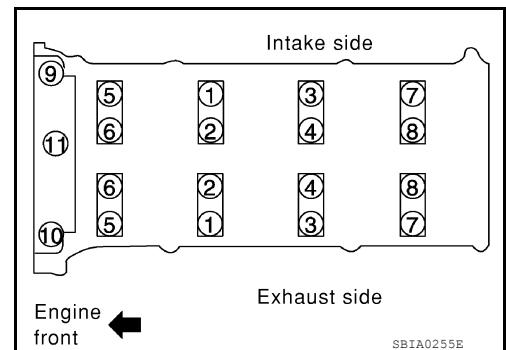

CAMSHAFT

[QR25DE]

< REMOVAL AND INSTALLATION >

5. Install camshaft sprockets.
 - Install them by lining up the mating marks on each camshaft sprocket with the ones painted on the timing chain during removal.
 - Before installation of chain tensioner, it is possible to re-match the marks on timing chain with the ones on each sprocket.

CAUTION:

- **Aligned mating marks could slip. Therefore, after matching them, hold the timing chain in place by hand.**
- **Before and after installing chain tensioner, check again to make sure that mating marks have not slipped.**

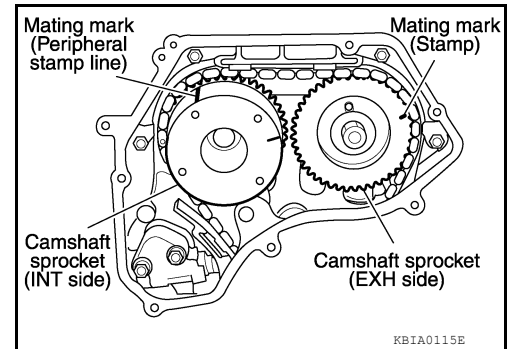

6. Install chain tensioner.

CAUTION:

- **After installation, pull the stopper pin off completely, and make sure that the tensioner is fully released.**

7. Install chain guide.

8. Install IVT control cover with the following procedure.

- a. Install IVT control solenoid valve to intake valve timing control cover.
- b. Install O-ring to front cover side.

CAUTION:

Do not reuse O-ring.

- c. Apply Genuine Silicone RTV Sealant to the positions as shown. Refer to [GI-15, "Recommended Chemical Products and Sealants"](#).

Diameter (A) : 3.0 - 4.0 mm (0.118 - 0.157 in)

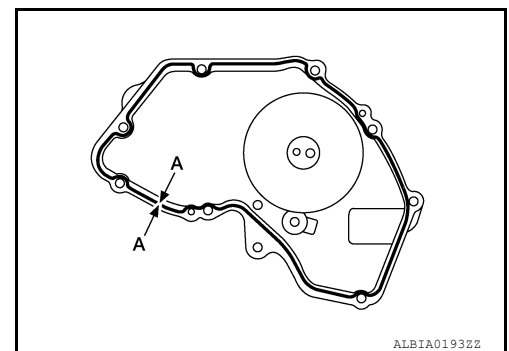

- d. Install IVT control cover.

- Tighten the bolts in the numerical order as shown.

9. Check and adjust valve clearances. Refer to [EM-50, "Valve Clearance"](#).

10. Installation of the remaining components is in the reverse order as shown.

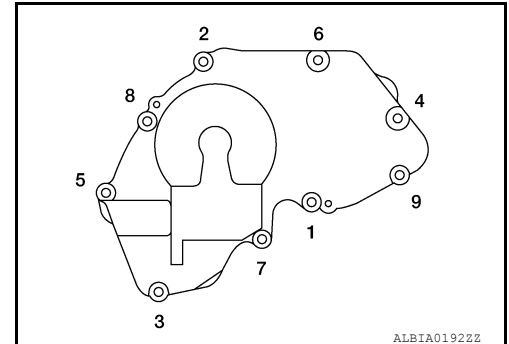

Inspection After Installation

INFOID:000000007420242

Inspection of Camshaft Sprocket (INT) Oil Groove

WARNING:

Check when engine is cold so as to prevent burns from any splashing engine oil.

CAUTION:

Perform this inspection only when DTC P0011 is detected in self-diagnostic results of CONSULT and it is directed according to inspection procedure of EC section. Refer to [EC-123, "Diagnosis Procedure"](#).

1. Check engine oil level. Refer to [LU-10, "Changing Engine Oil"](#).
2. Perform the following procedure so as to prevent the engine from being unintentionally started while checking.
 - a. Release fuel pressure. Refer to [EC-322, "Inspection"](#).
 - b. Disconnect ignition coil and injector harness connectors if practical.
3. Support engine using a suitable hoist or jack.
4. Remove the RH engine bracket, insulator and support bracket. Refer to [EM-74, "Removal and Installation"](#).
5. Remove IVT control solenoid valve. Refer to [EM-42](#).

CAMSHAFT

< REMOVAL AND INSTALLATION >

[QR25DE]

6. Crank engine, and then make sure that engine oil comes out from IVT control cover oil hole. End cranking after checking.

WARNING:

Be careful not to touch rotating parts (drive belts, idler pulley, and crankshaft pulley, etc.).

CAUTION:

- Engine oil may squirt from IVT control solenoid valve installation hole during cranking. Use a shop cloth to prevent engine oil from splashing on worker, engine components and vehicle.
- Do not allow engine oil to get on rubber components such as drive belts or engine insulators. Immediately wipe off any splashed engine oil.

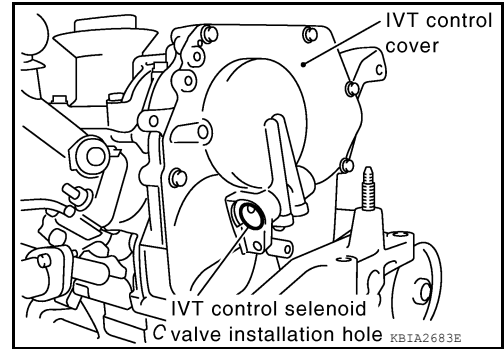

7. Clean oil groove between oil strainer and IVT control solenoid valve if engine oil does not come out from IVT control cover oil hole. Refer to [LU-7, "Lubrication Circuit"](#).
8. Remove components between IVT control solenoid valve and camshaft sprocket (INT), and then check each oil groove for clogging.
 - Clean oil groove if necessary. Refer to [LU-7, "Lubrication Circuit"](#).
9. After inspection, installation of the remaining components is in the reverse order of removal.

Valve Clearance

INFOID:000000007420243

Inspection

- Perform this inspection as follows after removal, installation, or replacement of the camshaft or any valve-related parts, or if there are any unusual engine conditions due to changes in valve clearance over time (starting, idling, and/or noise).
1. Warm up the engine, then stop it.
 2. Remove fender protector side cover (RH). Refer to [EXT-22, "Removal and Installation"](#) (Coupe models) or [EXT-46, "Removal and Installation"](#) (Sedan models).
 3. Remove the rocker cover using power tool. Refer to [EM-40, "Removal and Installation"](#).
 4. Turn crankshaft pulley in normal direction (clockwise when viewed from front) to align TDC identification mark (without paint mark) with timing indicator.
-
- A technical line drawing of the engine's timing belt area. It shows a 'Timing indicator' and a 'TDC mark' on the crankshaft pulley. A 'Mark' is also indicated on the timing belt. A small reference code 'KBIA0190E' is at the bottom right.
5. At this time, check that the both intake and exhaust cam lobes of No. 1 cylinder face outside.
 - If they do not face outside, turn crankshaft pulley once more.

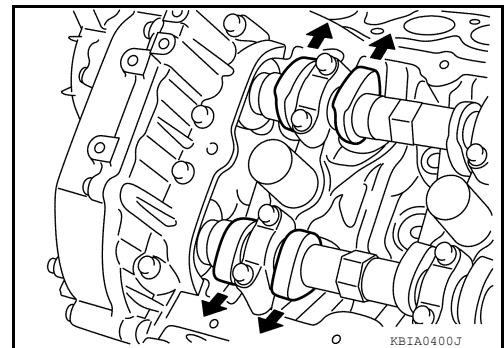
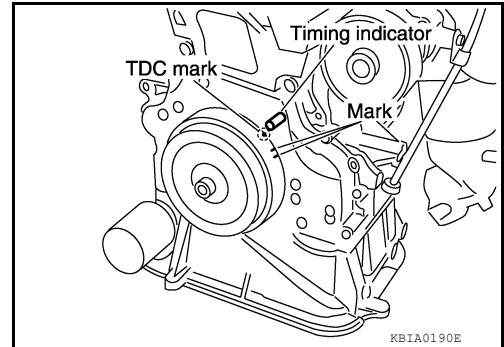

CAMSHAFT

[QR25DE]

< REMOVAL AND INSTALLATION >

- Measure valve clearances with a feeler gauge at locations marked (X) in the table below.
 - No.1 cylinder compression TDC.

Cylinder	No.1		No.2		No.3		No.4	
	INT	EXH	INT	EXH	INT	EXH	INT	EXH
Measurable	x	x	x			x		

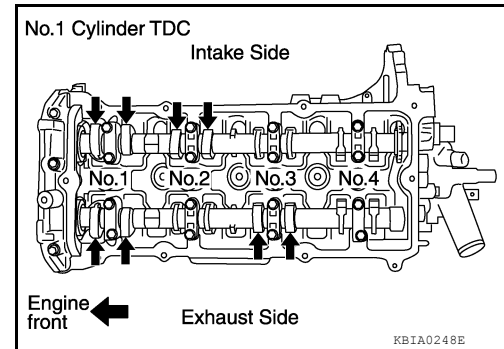

- Use a feeler gauge to measure the clearance between valve and camshaft.

Valve clearance standard:

Cold	Intake	: 0.24 - 0.32 mm (0.009 - 0.013 in)
	Exhaust	: 0.26 - 0.34 mm (0.010 - 0.013 in)
Hot*	Intake	: 0.304 - 0.416 mm (0.012 - 0.016 in)
	Exhaust	: 0.308 - 0.432 mm (0.012 - 0.017 in)

*Approximately 80°C (176°F)

CAUTION:

If inspection was carried out with cold engine, check that values with fully warmed up engine are still within specifications.

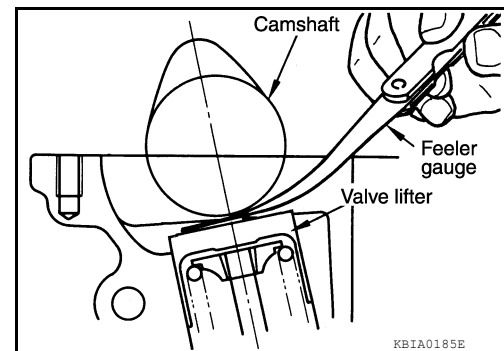

- Turn crankshaft one complete revolution (360°) and align mark on crankshaft pulley with pointer.
- Measure valve clearances with a feeler gauge at locations marked (X) in the table below.
 - No.4 cylinder compression TDC.

Cylinder	No.1		No.2		No.3		No.4	
	INT	EXH	INT	EXH	INT	EXH	INT	EXH
Measurable				x	x		x	x

- If out of specifications, make necessary adjustment.

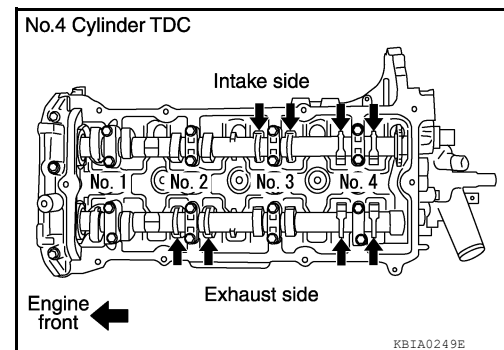

ADJUSTMENT

- Perform adjustment depending on selected head thickness of valve lifter.
 - The specified valve lifter thickness is the dimension at normal temperatures. Ignore dimensional differences caused by temperature. Use the specifications for hot engine condition to adjust.
- Remove camshaft. Refer to [EM-42. "Removal and Installation"](#).
 - Remove the valve lifters at the locations that are outside the standard.

CAMSHAFT

< REMOVAL AND INSTALLATION >

[QR25DE]

3. Measure the center thickness of the removed valve lifters with a micrometer.

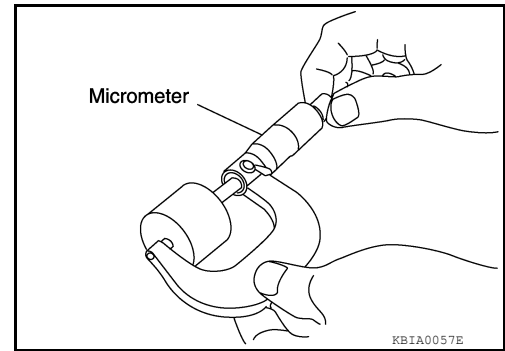

4. Use the equation below to calculate valve lifter thickness for replacement.

- Valve lifter thickness calculation.

$$t = t_1 + (C_1 - C_2)$$

t = Thickness of replacement valve lifter.

t₁ = Thickness of removed valve lifter.

C₁ = Measured valve clearance.

C₂ = Standard valve clearance.

- Thickness of a new valve lifter can be identified by stamp marks on the reverse side (inside the cylinder).
Stamp mark 696 indicates a thickness of 6.96 mm (0.2740 in)
Available thickness of valve lifter: 26 sizes with a range of 7.88 to 8.38 mm (0.3102 to 0.3299 in), in steps of 0.02 mm (0.0008 in), when assembled at the factory.

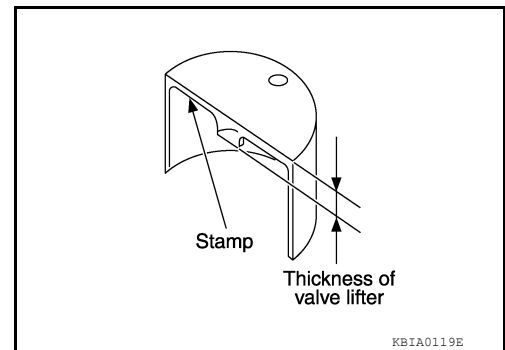

5. Install the selected valve lifter.
6. Install camshaft.
7. Manually turn crankshaft pulley a few turns.
8. Check that valve clearances for cold engine are within specifications, by referring to the specified values.
9. After completing the repair, check valve clearances again with the specifications for warmed engine. Use a feeler gauge to measure the clearance between the valve and camshaft. Make sure the values are within specifications.

Valve clearance standard:

Cold	Intake	: 0.24 - 0.32 mm (0.009 - 0.013 in)
	Exhaust	: 0.26 - 0.34 mm (0.010 - 0.013 in)
Hot*	Intake	: 0.304 - 0.416 mm (0.012 - 0.016 in)
	Exhaust	: 0.308 - 0.432 mm (0.012 - 0.017 in)

*: Approximately 80°C (176°F)

INTAKE VALVE TIMING CONTROL

< REMOVAL AND INSTALLATION >

[QR25DE]

INTAKE VALVE TIMING CONTROL

Intake Valve Timing Control Solenoid Valve

INFOID:000000007420244

REMOVAL

1. Disconnect intake valve timing control solenoid valve connector.
2. Remove intake valve timing control solenoid valve bolt.
3. Remove intake valve timing control solenoid valve (1) and O-ring (2) from intake valve timing control solenoid valve cover.

CAUTION:

Do not reuse O-ring.

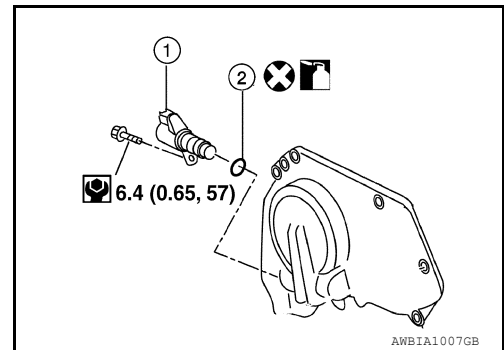

INSTALLATION

Installation is in the reverse order of removal.

CAUTION:

- Do not reuse O-ring.
- Replace the O-ring for the intake valve timing control solenoid valve with a new one, then lubricate O-ring with engine oil before installing.

TIMING CHAIN

< REMOVAL AND INSTALLATION >

[QR25DE]

TIMING CHAIN

Removal and Installation

INFOID:000000007420245

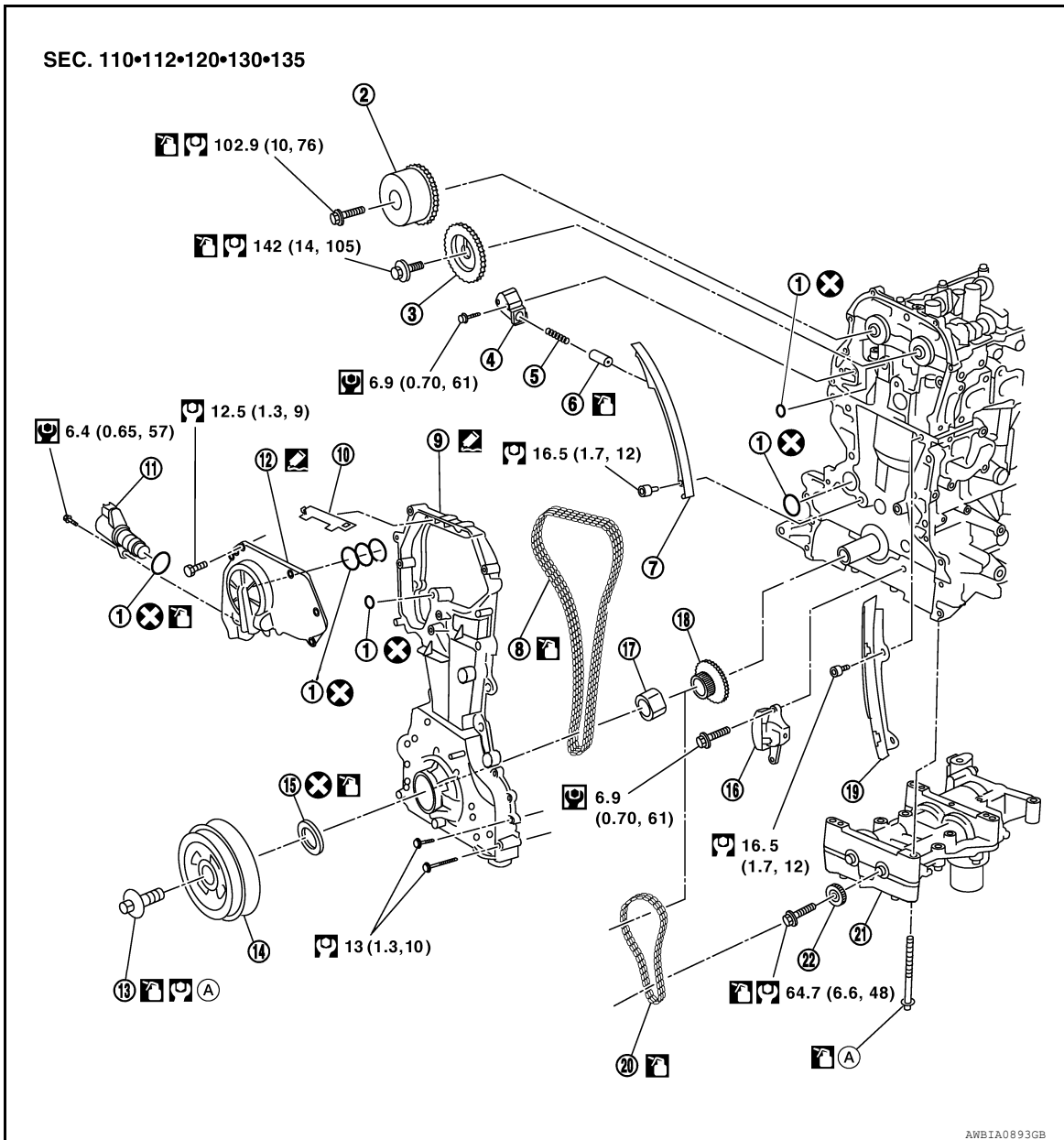

- | | | |
|--|--------------------------------------|----------------------------|
| 1. O-rings | 2. Camshaft sprocket (INT) | 3. Camshaft sprocket (EXH) |
| 4. Chain tensioner | 5. Spring | 6. Chain tensioner plunger |
| 7. Timing chain slack guide | 8. Timing chain | 9. Front cover |
| 10. Chain guide | 11. IVT solenoid valve | 12. IVT cover |
| 13. Crankshaft pulley bolt | 14. Crankshaft pulley | 15. Front oil seal |
| 16. Balancer unit timing chain tensioner | 17. Oil pump drive spacer | 18. Crankshaft sprocket |
| 19. Timing chain tension guide | 20. Balancer unit timing chain | 21. Balancer unit |
| 22. Balancer unit sprocket | A. Follow the installation procedure | |

CAUTION:

Apply new engine oil to parts as indicated in the illustration before installation.

REMOVAL

1. Remove the engine and transaxle assembly. Refer to [EM-74, "Removal and Installation"](#).

TIMING CHAIN

[QR25DE]

< REMOVAL AND INSTALLATION >

2. Remove the upper and lower oil pan, and oil strainer. Refer to [EM-32. "Removal and Installation"](#).
3. Remove generator. Refer to [CHG-26. "Removal and Installation"](#).
4. Disconnect variable timing control solenoid harness connector.
5. Loosen IVT (intake valve timing) control cover bolts in the numerical order as shown.

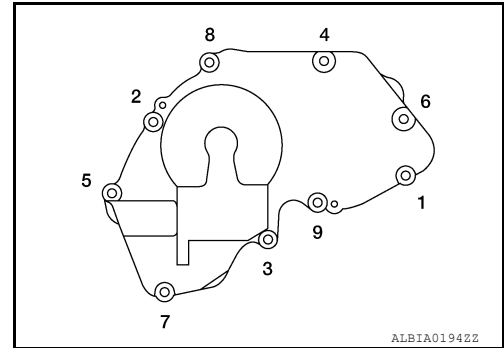

Remove the IVT control cover using Tool.

Tool number : KV10111100 (J-37228)

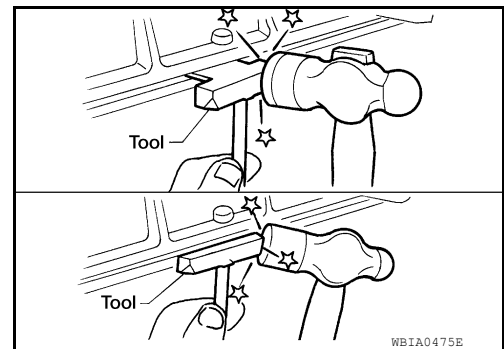

6. Set the No.1 cylinder at TDC on the compression stroke with the following procedure:
 - a. Rotate the crankshaft pulley clockwise and align the mating marks to the timing indicator on the front cover.

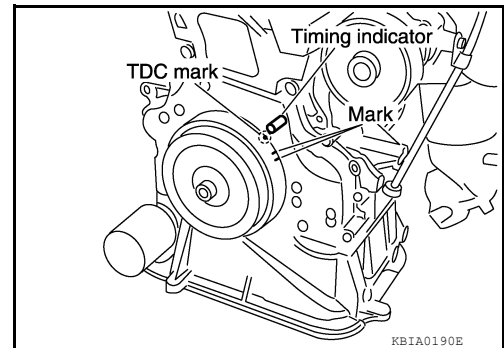

- b. At the same time, make sure that the mating marks on the camshaft sprockets are lined up as shown.
 - If not lined up, rotate the crankshaft pulley one more turn to line up the mating marks to the positions as shown.

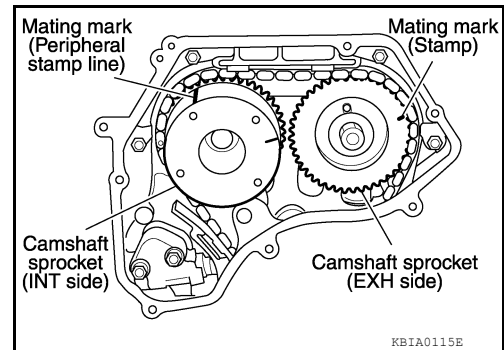

TIMING CHAIN

[QR25DE]

< REMOVAL AND INSTALLATION >

7. Remove crankshaft pulley with the following procedure:
- Hold the crankshaft pulley using suitable tool, then loosen the crankshaft pulley bolt, and pull the pulley out about 10 mm (0.39 in).

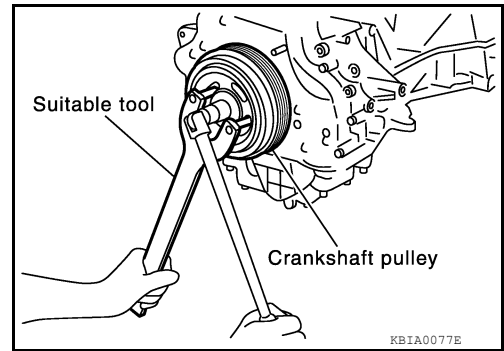

- Attach suitable pulley puller in the M 6 (0.24 in diameter) thread hole on crankshaft pulley, and remove crankshaft pulley using a suitable puller.

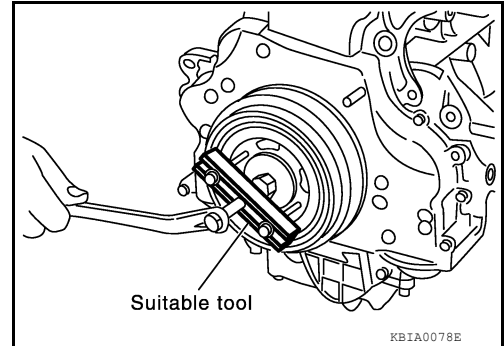

8. Remove the front cover with the following procedure:
- Loosen the bolts in the numerical order as shown, and remove them.
 - Remove the front cover.
CAUTION:
 - Be careful not to damage the mounting surface.
 - Remove front oil seal using suitable tool, if necessary.

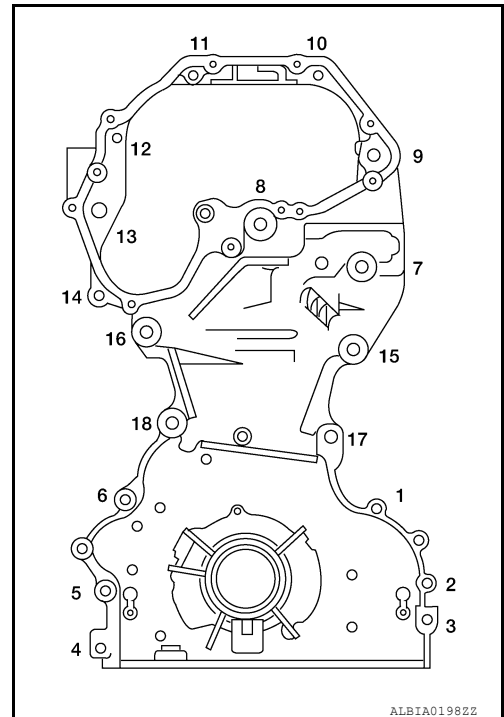

10. Remove timing chain with the following procedure:
- Push in the tensioner plunger. Insert a stopper pin into the hole on the tensioner body to secure the chain tensioner plunger and remove chain tensioner.
 - Use a wire of 0.5 mm (0.02 in) diameter as a stopper pin.
 - Remove the timing chain.

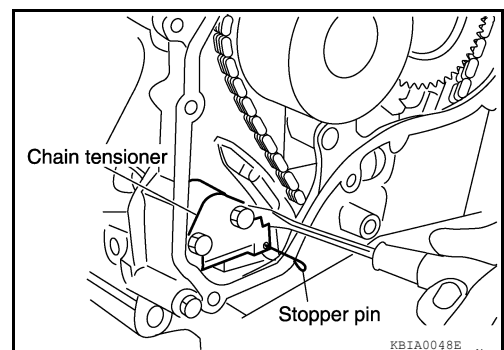

TIMING CHAIN

[QR25DE]

< REMOVAL AND INSTALLATION >

- c. Secure hexagonal part of the camshaft with a wrench and loosen the camshaft sprocket bolt and remove the camshaft sprocket for both camshafts.

CAUTION:

- Do not rotate the crankshaft or camshafts while the timing chain is removed. It can cause damage to the valves and pistons.

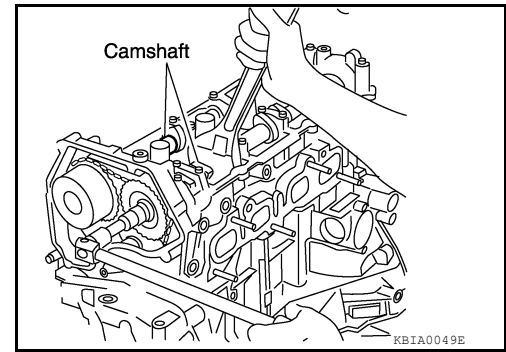

11. Remove the chain slack guide, tension guide, timing chain, and oil pump drive spacer.

12. Press stopper tab (A) in the direction shown to push the timing chain slack guide (B) toward timing chain tensioner (for balancer unit) (1).

- The slack guide (B) is released by pressing the stopper tab (A). As a result, the slack guide (B) can be moved.

13. Insert stopper pin (D) into tensioner body hole (C) to secure timing chain slack guide (B).

NOTE:

Use a hard metal pin with a diameter of approximately 1.2 mm (0.047 in) as a stopper pin.

14. Remove timing chain tensioner (for balancer unit) (1).
15. Secure width across flats of the balancer LH side shaft using a suitable tool. Loosen the balancer sprocket bolt.
16. Remove balancer unit timing chain, balancer unit sprocket and crankshaft sprocket.

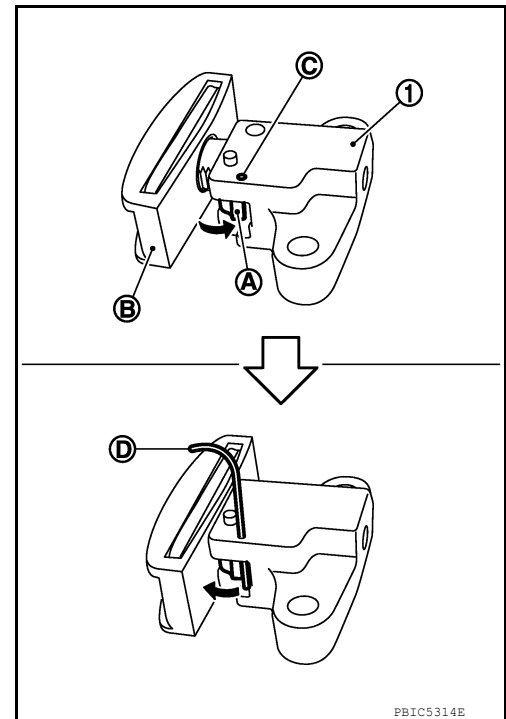

17. Loosen bolts in order as shown, and remove balancer unit.

CAUTION:

- Do not disassemble balancer unit.

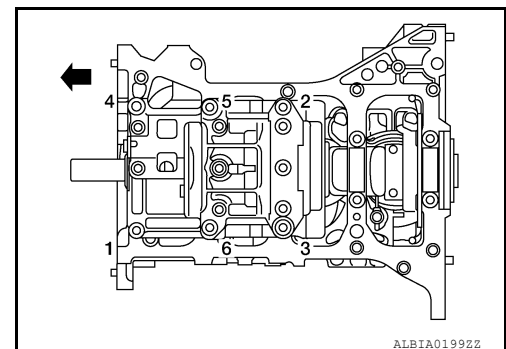

INSPECTION AFTER REMOVAL

Timing Chain

A
EM
C
D
E
F
G
H
I
J
K
L
M
N
O
P

TIMING CHAIN

[QR25DE]

< REMOVAL AND INSTALLATION >

Check the timing chain for cracks or excessive wear. If a defect is detected, replace it.

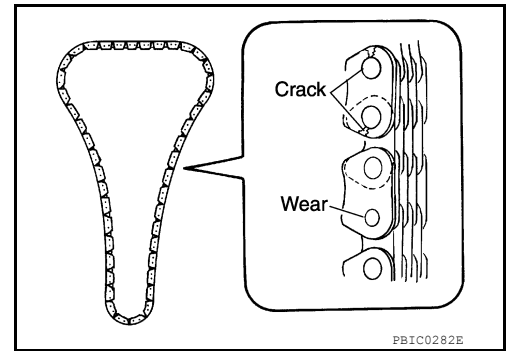

PBIC0282E

Balancer Unit Bolt Outer Diameter

- Measure outer diameters (d1, d2) at the two positions as shown.
- Measure d2 within the range A.
- If the value difference (d1 - d2) exceeds the limit, replace it with a new one.

Limit : 0.15 mm (0.0059 in) or more

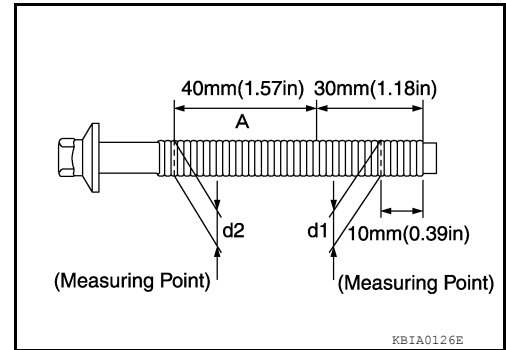

KBIA0126E

INSTALLATION

NOTE:

- There may be two color variations of the link marks (link colors) on the timing chain.
- There are 26 links between the blue mating marks on the timing chain; and 64 links between the camshaft sprocket blue link and the crankshaft sprocket orange link, on the timing chain side without the tensioner.

1. Make sure the crankshaft key points straight up.
2. Install the balancer unit and tighten the bolts in the numerical order as shown:

CAUTION:

- **When reusing a bolt, check its outer diameter before installation. Follow the Balancer Unit Bolt Outer Diameter procedure.**
- **Apply new engine oil to threads and seating surfaces of bolts.**

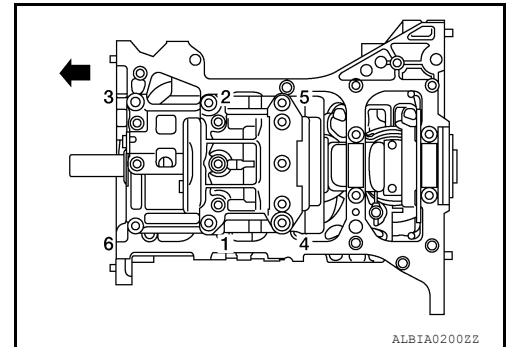

ALBIA0200ZZ

- **Check tightening angle with an angle wrench (A) or a protractor. Do not make judgment by visual check alone.**

Tool number : KV10112100 (BT-8653-A)

Balancer unit bolts

Step 1

Bolts 1-5 : 42 N·m (4.3 kg-m, 31 ft-lb)

Bolt 6 : 36 N·m (3.7 kg-m, 27 ft-lb)

Step 2

Bolts 1-5 : 120° + 5°

Bolt 6 : 90° + 5°

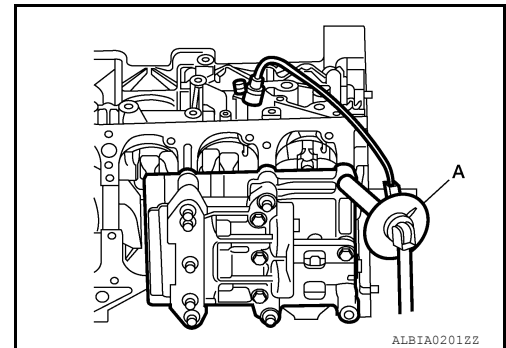

ALBIA0201ZZ

TIMING CHAIN

< REMOVAL AND INSTALLATION >

[QR25DE]

Step 3 (Loosen in reverse order of tightening) : 0 N·m (0 kg-m, 0 ft-lb)

Step 4

Bolts 1-5 : 42 N·m (4.3 kg-m, 31 ft-lb)

Bolt 6 : 36 N·m (3.7 kg-m, 27 ft-lb)

Step 5

Bolts 1-5 : 120° + 5°

Bolt 6 : 90° + 5°

3. Install the crankshaft sprocket (1) and timing chain (2) for the balancer unit.

- Make sure that the crankshaft sprocket (1) is positioned with mating marks (A) on the block and sprocket meeting at the top.
- Install it by lining up mating marks on each sprocket (A), (C) and timing chain (B), (D).
- B: Blue link
- D: Orange link

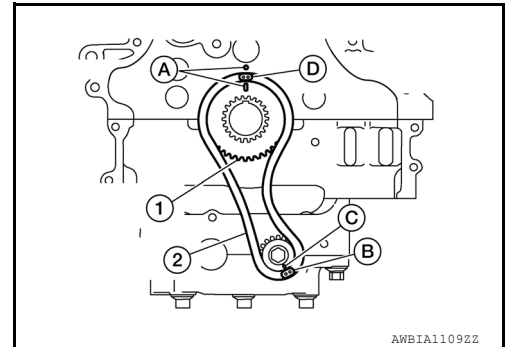

4. Install timing chain tensioner (for balancer unit) (1).

- Fix the plunger at the most compressed position using a stopper pin (A), and then install it.
- Securely pull out (←) the stopper pin after installing the timing chain tensioner (for balancer unit).
- Check matching mark position of balancer unit drive chain and each sprocket again.

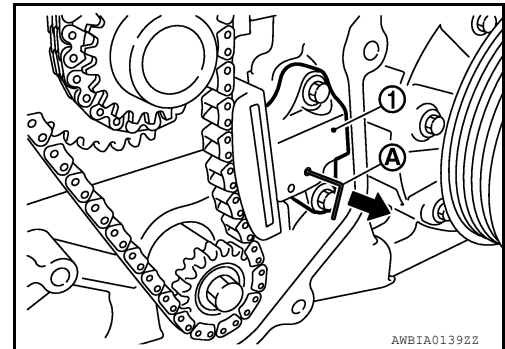

5. Install timing chain (1) and related parts.

- Install by lining up mating marks on each sprocket and timing chain as shown.
- Before and after installing chain tensioner (3), check again to make sure the mating marks have not slipped.
- After installing timing chain tensioner (3), remove the stopper pin, and make sure that the tensioner moves freely.

CAUTION:

- **For the following note, after the mating marks are aligned, keep them aligned by holding them by hand.**
- **To avoid skipped teeth, do not move crankshaft and camshaft until front cover is installed.**

NOTE:

Before installing chain tensioner (3), it is possible to change the position of mating mark on timing chain for that of each sprocket for alignment.

- 2: Camshaft sprocket (INT)
- 4: Timing chain slack guide
- 5: Crankshaft key
- 6: Crankshaft sprocket
- 7: Balancer unit sprocket
- 8: Balancer unit chain tensioner
- 9: Balancer unit timing chain
- 10: Timing chain tension guide
- 11: Camshaft sprocket (EXH)

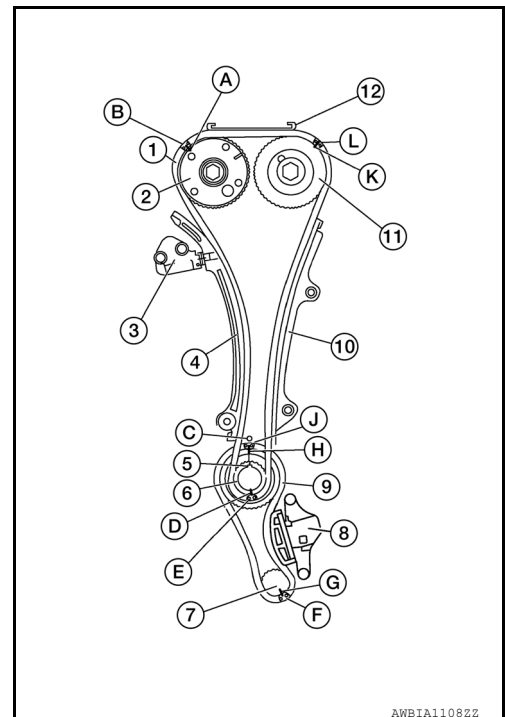

A
EM
C
D
E
F
G
H
I
J
K
L
M
N
O
P

TIMING CHAIN

[QR25DE]

< REMOVAL AND INSTALLATION >

- 12: Chain guide
- A: Mating mark (peripheral stamp line)
- B: Blue link
- C: Mating mark (lug)
- D: Mating mark (stamp)
- E: Orange link
- F: Blue link
- G: Mating mark (stamp)
- H: Mating mark (stamp)
- J: Orange link
- K: Mating mark (stamp)
- L: Blue link

6. Install new front oil seal to front cover, using suitable tool
- Install new oil seal in until it is flush with front end surface of front cover.

CAUTION:

- Do not reuse oil seal.
- Be careful not to cause damage to circumference of oil seal.

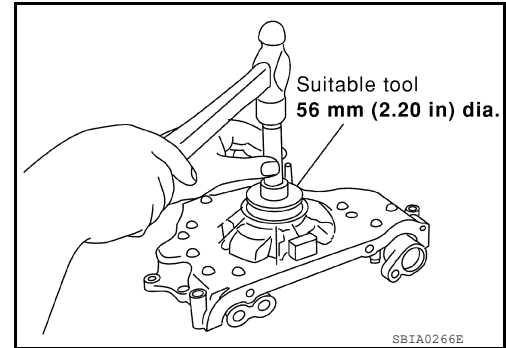

7. Install front cover with the following procedure:
- a. Install O-rings (B) to cylinder head and cylinder block.

CAUTION:

Do not reuse O-rings.

- b. Apply Genuine Silicone RTV Sealant or equivalent, to positions (A) specified as shown. Refer to [GI-15, "Recommended Chemical Products and Sealants"](#).

Sealant diameter (C) : 3.9 mm (0.154 in)

- c. Make sure the mating marks on the timing chain and each sprocket are still aligned. Then install the front cover.

CAUTION:

- Be careful not to damage the front oil seal during installation with the front end of the crankshaft.

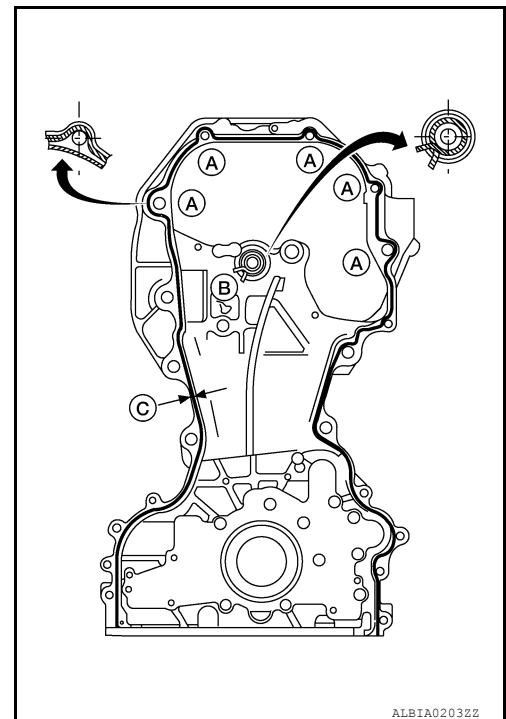

TIMING CHAIN

[QR25DE]

< REMOVAL AND INSTALLATION >

- d. Tighten front cover bolts in the numerical order as shown.
- e. After all bolts are tightened, retighten them to the specified torque.

Front cover bolts

- Bolts (A)** : 49 N·m (5.0 kg-m, 36 ft-lb)
Bolts (B) : 12.7 N·m (1.3 kg-m, 9 ft-lb)
Bolts (C) : 12.7 N·m (1.3 kg-m, 9 ft-lb)
Bolts (D) : 49 N·m (5.0 kg-m, 36 ft-lb)
(E) Dowel pins

CAUTION:

Wipe off any excess sealant leaking at the surface for installing the oil pan.

8. Install the chain guide between the camshaft sprockets.

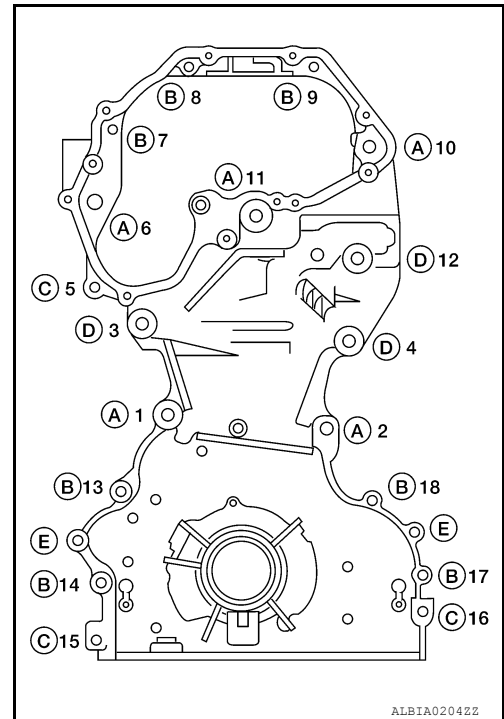

9. Install IVT cover with the following procedure:
 - a. Install IVT solenoid valve to IVT cover.
 - b. Install new O-ring to front cover.

CAUTION:

Do not reuse O-ring.

- c. Apply Silicone RTV Sealant to the IVT cover as shown.
 - Apply Genuine Silicone RTV Sealant or equivalent, to positions specified as shown. Refer to [GI-15, "Recommended Chemical Products and Sealants"](#).

- Diameter (A)** : 3.0 - 4.0 mm (0.118 - 0.157 in)

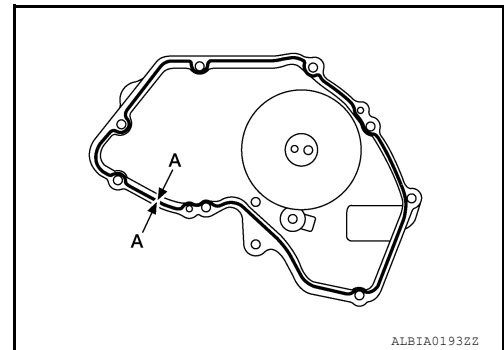

- d. Tighten the IVT cover bolts in the numerical order as shown.

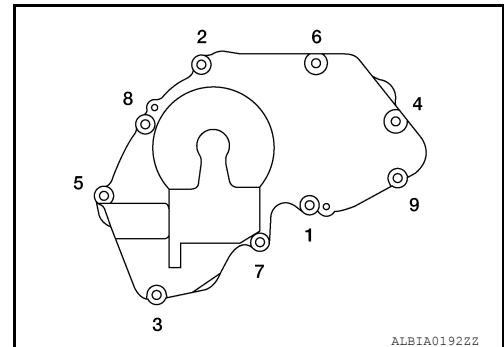

10. Insert crankshaft pulley by aligning with crankshaft key.
 - Tap its center with a plastic hammer to insert.
 - Do not tap the belt hook.
11. Tighten crankshaft pulley bolts.
 - Secure crankshaft pulley with tool to tighten the bolt.
 - Perform angle tightening with the following procedure:

TIMING CHAIN

[QR25DE]

< REMOVAL AND INSTALLATION >

- a. Apply new engine oil to threads and seat surfaces of bolts.
- b. Tighten to initial specifications:

Crankshaft bolt : 42.1 N·m (4.3 kg-m, 31 ft-lb)

- c. Apply a paint mark on the front cover, mating with any one of six easy to recognize stamp marks on bolt flange.
 - d. Turn crankshaft pulley bolt another 60° to 66° degrees [Target: 60° degrees].
 - Check vertical mounting angle with movement of one stamp mark.
12. Installation of the remaining components is in the reverse order of removal.

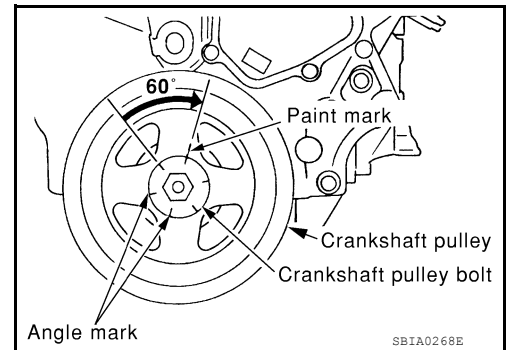

OIL SEAL

Removal and Installation of Valve Oil Seal

INFOID:000000007420246

REMOVAL

1. Remove camshaft. Refer to [EM-42, "Removal and Installation"](#).
2. Remove valve lifter. Refer to [EM-42, "Removal and Installation"](#).
3. Rotate crankshaft, and set piston whose oil seal is to be removed to top dead center. This prevents valve from dropping inside cylinder.

CAUTION:

When rotating crankshaft, be careful to avoid scarring the front cover with the timing chain.

4. Remove valve collet, valve spring retainer and valve spring using Tool.

Tool number

: KV10116200 (J-26336-B)

: KV10115900 (J-26336-20)

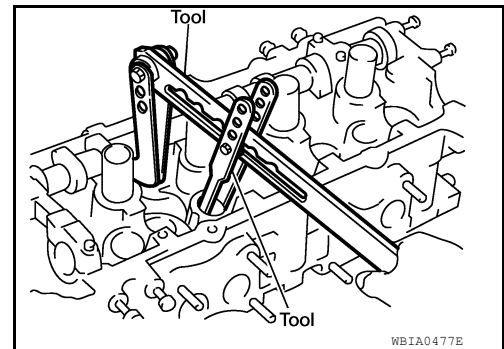

5. Remove valve oil seal using Tool.

Tool number : KV10107902 (J-38959)

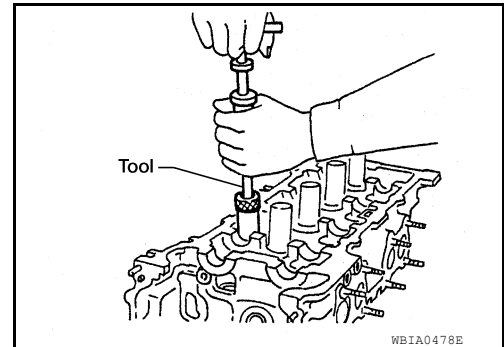

INSTALLATION

1. Apply new engine oil to new valve oil seal joint surface and seal lip.
2. Press in valve oil seal to the position shown using Tool.

Oil seal installed height (A) : 12.1 mm (0.476 in)

Tool number : KV10115600 (J-38958)

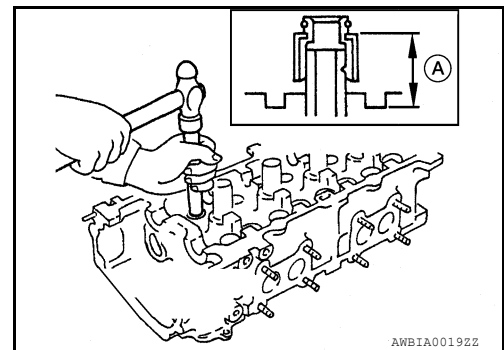

3. Installation of the remaining components is in the reverse order of removal.

Removal and Installation of Front Oil Seal

INFOID:000000007420247

REMOVAL

1. Remove the following parts:
 - RH front wheel. Refer to [WT-68, "Adjustment"](#).

OIL SEAL

[QR25DE]

< REMOVAL AND INSTALLATION >

- Fender protector side cover (RH). Refer to [EXT-22. "Removal and Installation"](#) (Coupe models) or [EXT-46. "Removal and Installation"](#) (Sedan models).
 - Drive belt. Refer to [EM-16](#).
 - Crankshaft pulley. Refer to [EM-54](#).
2. Remove front oil seal from front cover.
- CAUTION:**
Be careful not to scratch front cover.

INSTALLATION

1. Install new front oil seal to front cover using suitable tool.
- Install new oil seal in until it is flush with front end surface of front cover.
- CAUTION:**
- **Do not reuse oil seal.**
 - **Be careful not to cause damage to circumference of oil seal.**

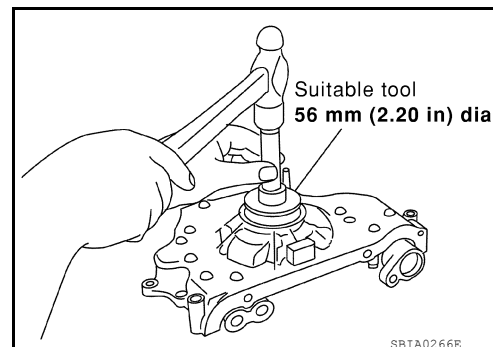

- Install new oil seal in the direction shown.

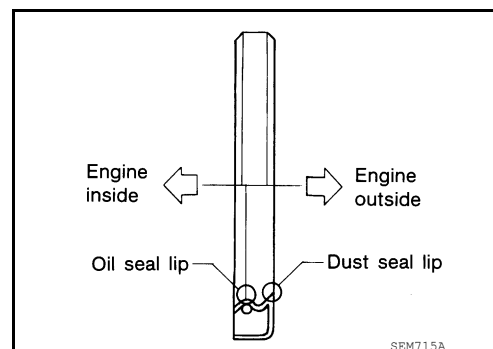

2. Installation of the remaining components is in the reverse order of removal.

Removal and Installation of Rear Oil Seal

INFOID:000000007420248

REMOVAL

1. Remove the transaxle. Refer to [TM-29. "Removal and Installation"](#) (M/T), [TM-420. "Removal and Installation"](#) (CVT).
2. Remove flywheel (MT) or drive plate (CVT).
3. Remove rear oil seal using suitable tool.
- CAUTION:**
Be careful not to scratch rear oil seal retainer.

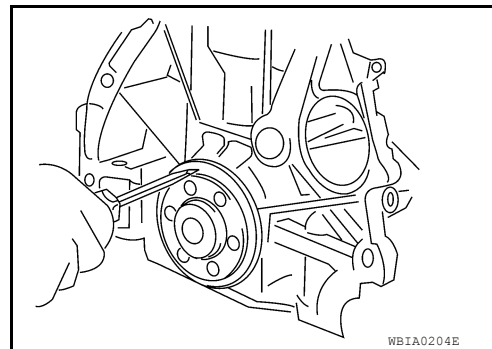

INSTALLATION

1. Apply new engine oil to new oil seal and install it using a suitable tool.

OIL SEAL

< REMOVAL AND INSTALLATION >

[QR25DE]

- Install new oil seal in the direction shown.

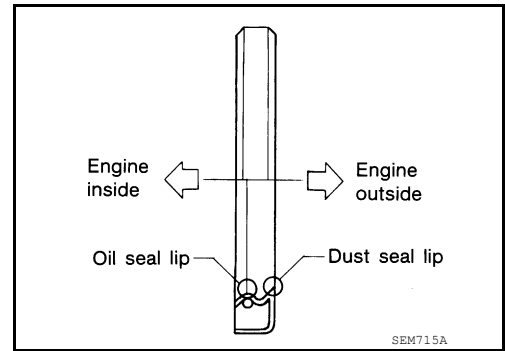

- Press fit new oil seal straight using a suitable drift, to avoid causing burrs or tilting.

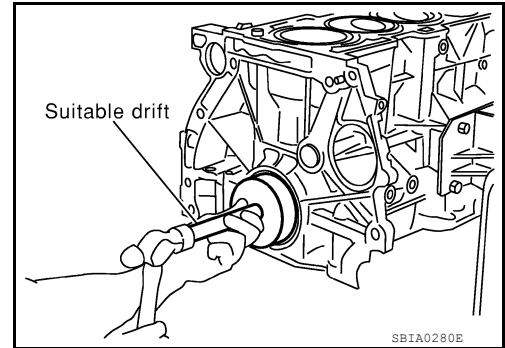

- Press in the new oil seal to the specified depth as shown.

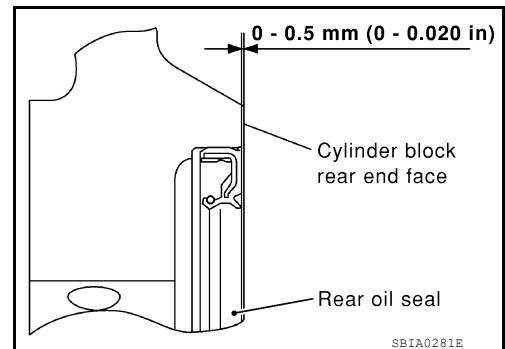

2. Installation of the remaining components is in the reverse order of removal.

A
EM
C
D
E
F
G
H
I
J
K
L
M
N
O
P

CYLINDER HEAD

< REMOVAL AND INSTALLATION >

[QR25DE]

CYLINDER HEAD

Removal and Installation

INFOID:000000007420249

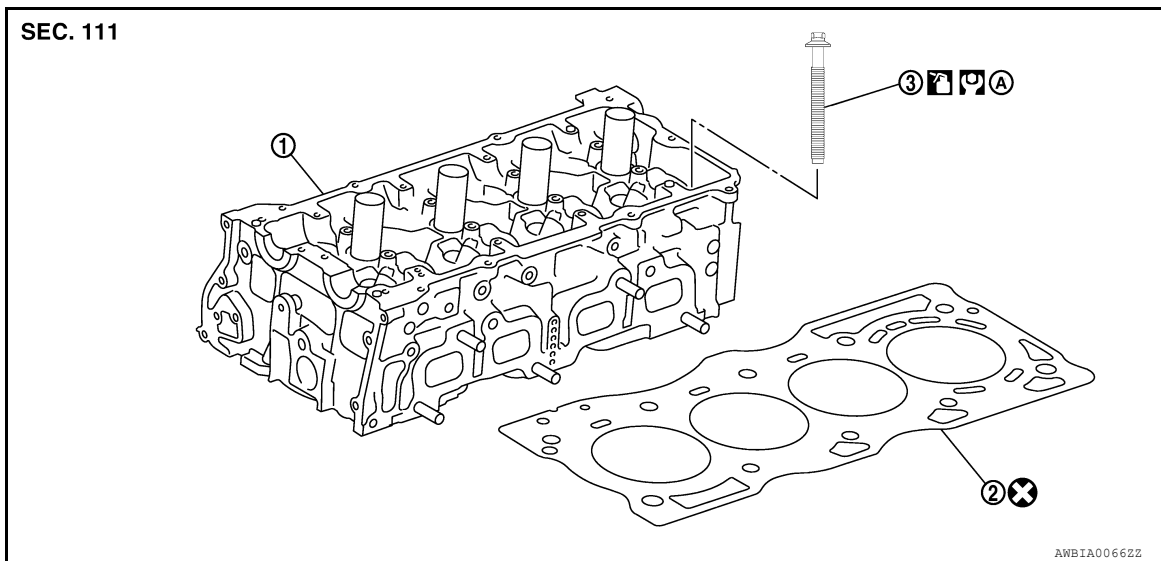

1. Cylinder head
 2. Cylinder head gasket
 3. Cylinder head bolt
- A. Follow installation procedure

REMOVAL

1. Remove the timing chain. Refer to [EM-54, "Removal and Installation"](#).
2. Remove the camshafts. Refer to [EM-42](#).
3. Remove spark plugs. Refer to [EM-14, "Removal and Installation"](#).
4. Remove the exhaust manifold and three way catalyst. Refer to [EM-30, "Removal and Installation"](#).
5. Remove cylinder head loosening bolts in the order as shown, using power tool.
6. Remove cylinder head.
7. Remove cylinder head gasket.
8. If necessary to transfer to new cylinder head or remove for reconditioning, remove the intake manifold collector, intake manifold, and fuel tube assembly. Refer to [EM-68, "Disassembly and Assembly"](#).

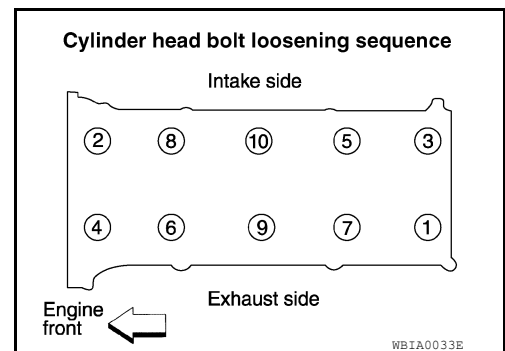

INSPECTION AFTER REMOVAL

Outer Diameter of Cylinder Head Bolts

- Cylinder head bolts are tightened by plastic zone tightening method. Whenever the size difference between d1 and d2 exceeds the limit, replace the bolts with new ones.

CYLINDER HEAD

< REMOVAL AND INSTALLATION >

[QR25DE]

Limit (d1 - d2) : 0.23 mm (0.0091 in) or less

- If reduction of outer diameter appears in a position other than d2, use it as d2 point.

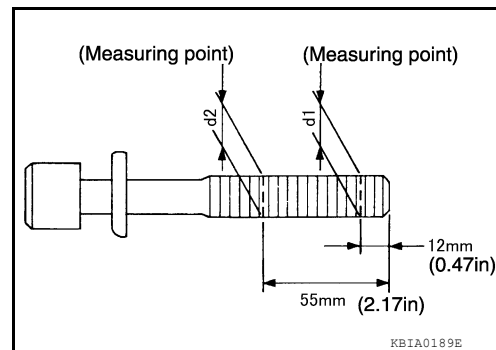

INSTALLATION

1. Install a new cylinder head gasket.
2. Install the cylinder head.
3. Follow the steps below to tighten the cylinder head bolts in the numerical order as shown.
 - Apply new engine oil to the threads and the seating surfaces of bolts.

CAUTION:

- If cylinder head bolts are re-used, check their outer diameters before installation. Follow the **Outer Diameter of Cylinder Head Bolts measurement procedure**.
- Check and confirm the tightening angle by using angle wrench or protractor. Avoid judgment by visual inspection without the tool.

Tool number : KV10112100 (BT-8653-A)

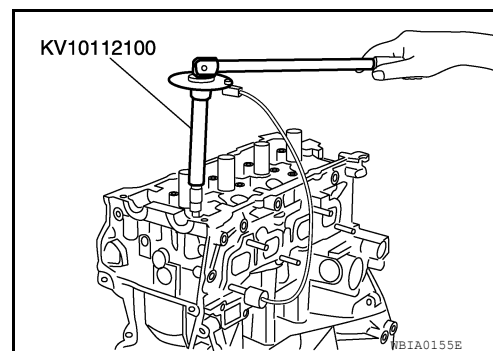

Step a : 55.0 N·m (5.6 kg-m, 41 ft-lb)

Step b : Loosen to 0 N·m in the reverse numerical order shown

Step c : 39.2 N·m (4.0 kg-m, 29 ft-lb)

Step d : 75° clockwise

Step e : 75° clockwise

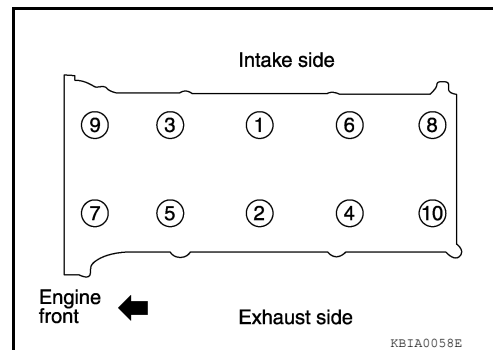

4. Installation of the remaining components is in the reverse order of removal.

CYLINDER HEAD

< REMOVAL AND INSTALLATION >

[QR25DE]

Disassembly and Assembly

INFOID:000000007420250

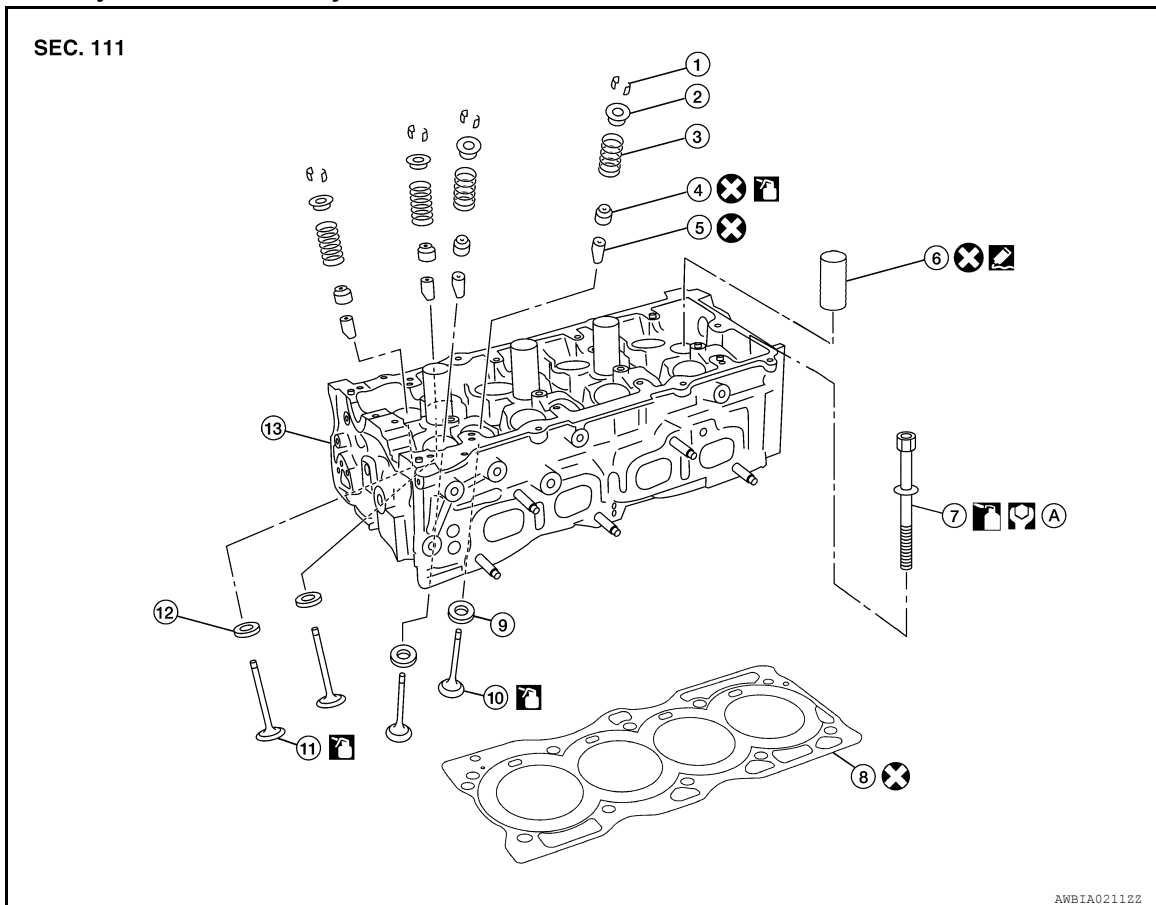

- | | | |
|-----------------------|----------------------------------|----------------------|
| 1. Valve collet | 2. Valve spring retainer | 3. Valve spring |
| 4. Valve oil seal | 5. Valve guide | 6. Spark plug tube |
| 7. Cylinder head bolt | 8. Cylinder head gasket | 9. Valve seat (EXH) |
| 10. Valve (EXH) | 11. Valve (INT) | 12. Valve seat (INT) |
| 13. Cylinder head | A. Follow installation procedure | |

CAUTION:

- When installing camshafts, chain tensioners, oil seals or other sliding parts, lubricate contacting surfaces with new engine oil.
- Apply new engine oil to threads and seat surfaces when installing the cylinder head, camshaft sprocket, crankshaft pulley and camshaft bracket.
- Attach tags to valve lifters so all parts are assembled in their original position.

DISASSEMBLY

1. Remove the valve lifter.
 - Mark the valve lifter location so they are installed in the same location.
2. Remove the valve collet, valve spring retainer and valve spring using Tool.

Tool number : KV10116200 (J-26336-B)
: KV10115900 (J-26336-20)

CAUTION:

Do not remove valve spring seat from valve spring.

3. Push valve stem to combustion chamber side, and remove valve.
 - Inspect valve guide clearance before removal. Refer to [EM-70, "Inspection After Disassembly"](#).
 - Confirm installation point.

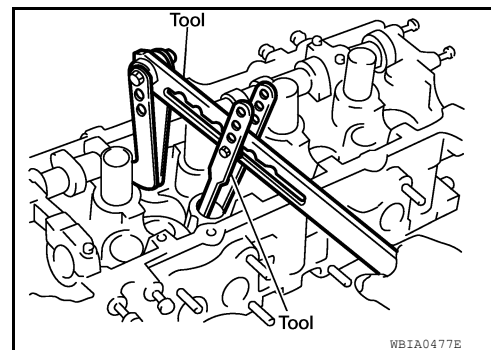

CYLINDER HEAD

< REMOVAL AND INSTALLATION >

[QR25DE]

4. Remove valve oil seal using Tool.

Tool number : KV10107902 (J-38959)

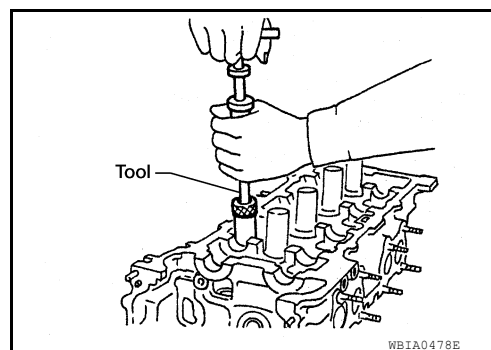

5. When valve seat must be replaced, refer to [EM-70, "Inspection After Disassembly"](#).
6. When valve guide must be replaced, refer to [EM-70, "Inspection After Disassembly"](#).
7. Remove spark plug tubes, if necessary using suitable tool.
- CAUTION:**
- Be careful not to damage cylinder head.
 - Do not remove spark plug tube if not necessary. Once removed, the spark plug tube cannot be reused because of deformation during removal.

ASSEMBLY

1. Install valve guide. Refer to [EM-70, "Inspection After Disassembly"](#).
2. Install valve seat. Refer to [EM-70, "Inspection After Disassembly"](#).
3. Install new valve oil seal using Tool as shown.

Oil seal installed height (A) : 12.1 mm (0.476 in)

Tool number : KV10115600 (J-38958)

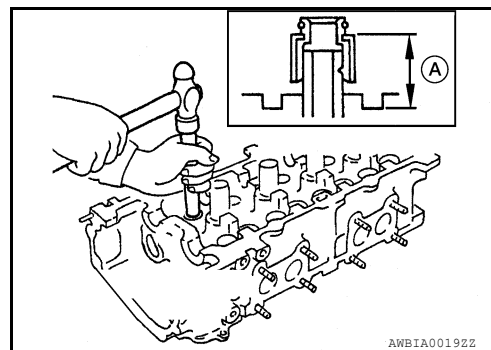

4. Install valve.
- Install larger diameter to intake side.
5. Install valve spring.
- Install valve spring so that the identification color faces upwards.
 - Confirm the identification color of the valve spring.
 - Intake: pink
 - Exhaust: green
6. Install valve spring retainer.
7. Install valve collet using Tool.
- Compress valve spring with valve spring compressor. Install valve collet with magnet hand.
 - Tap stem edge lightly with plastic hammer after installation to check its installed condition.

Tool number : KV10116200 (J-26336-B)
: KV10115900 (J-26336-20)

8. Install valve lifter.

CYLINDER HEAD

[QR25DE]

< REMOVAL AND INSTALLATION >

9. Install spark plug tube.
 - a. Remove old liquid gasket from cylinder head side hole.
 - b. Apply liquid gasket all around on spark plug tube with a 12 mm (0.47 in) width from edge of spark plug tube on the press fit side.
 - Use Three Bond or equivalent. Refer to [GI-15, "Recommended Chemical Products and Sealants"](#).
 - c. Press fit spark plug tube so that height is to (H) as shown.

Press fit height (H) standard value : 41.7 mm (1.642 in)

CAUTION:

- When press fitting be careful not to deform spark plug tube.
- After press fitting, wipe off any protruding liquid gasket on top surface of cylinder head.

10. Install spark plug using suitable tool.

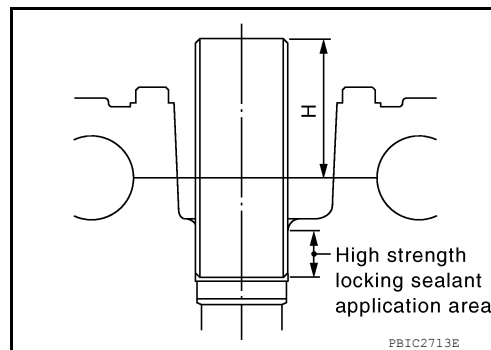

Inspection After Disassembly

INFOID:000000007420251

CYLINDER HEAD DISTORTION

1. Wipe off oil and remove water scale deposits, old gasket, old sealer, and carbon with a scraper.

CAUTION:

Use care not to allow gasket debris to enter passages for oil or water.

2. At each of several locations on bottom surface of cylinder head, measure distortion in six directions.

Limit : 0.1 mm (0.004 in)

- If it exceeds the limit, replace cylinder head.

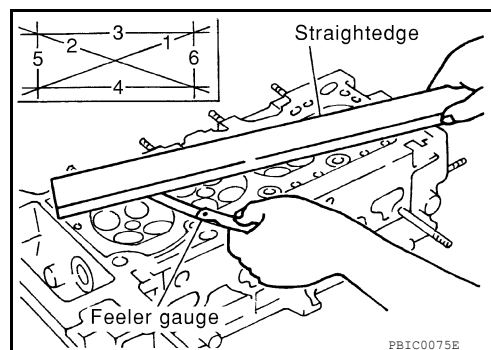

VALVE DIMENSIONS

Check dimensions of each valve. Refer to [EM-101, "Standard and Limit"](#).

VALVE GUIDE CLEARANCE

- Measure diameter of valve stem using suitable tool (A) as shown.

Standard

Intake : 5.965 - 5.980 mm (0.2348 - 0.2354 in)

Exhaust : 5.955 - 5.970 mm (0.2344 - 0.2350 in)

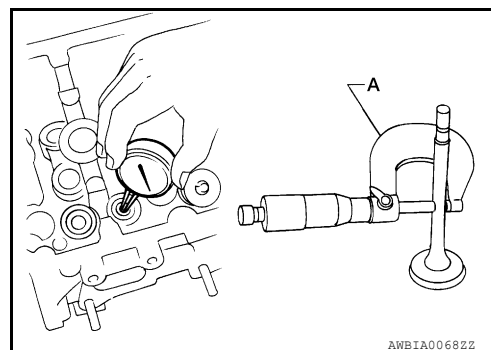

- Measure inner diameter of valve guide with a bore gauge

Standard

Intake and Exhaust : 6.000 - 6.018 mm (0.2362 - 0.2369 in)

- (Valve guide clearance) = (Valve guide inner diameter) - (Valve stem diameter)

Valve guide clearance

Standard

Intake : 0.020 - 0.053 mm (0.0008 - 0.0021 in)

CYLINDER HEAD

< REMOVAL AND INSTALLATION >

[QR25DE]

Exhaust	: 0.030 - 0.063 mm (0.0012 - 0.0025 in)
Limit	
Intake	: 0.08 mm (0.003 in)
Exhaust	: 0.09 mm (0.004 in)

- If it exceeds the limit, replace valve guide and/or valve. When valve guide must be replaced, follow the "VALVE GUIDE REPLACEMENT" procedure.

VALVE GUIDE REPLACEMENT

When valve guide is removed, replace with oversized (0.2 mm, 0.008 in) valve guide.

1. To remove valve guide, heat cylinder head to 110° to 130°C (230° to 266°F) by soaking in heated oil.

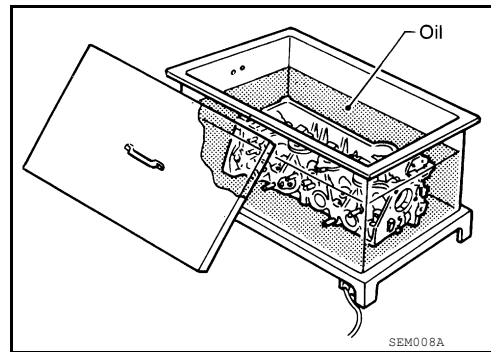

2. Drive out valve guide with a press [under a 20 kN (2.2 ton-force) pressure] or hammer and suitable tool.

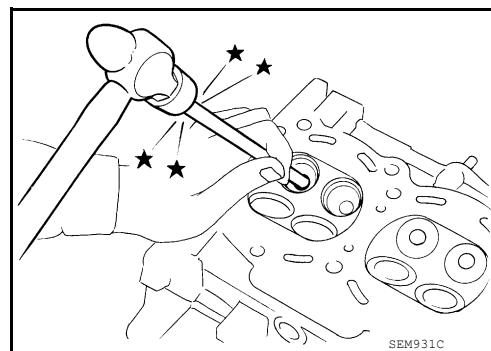

3. Ream cylinder head valve guide hole using suitable reamer.

Intake and exhaust valve guide hole diameter (Service) : 10.175 - 10.196 mm (0.4006 - 0.4014 in)

4. Heat cylinder head to 110° to 130°C (230° to 266°F) by soaking in heated oil.

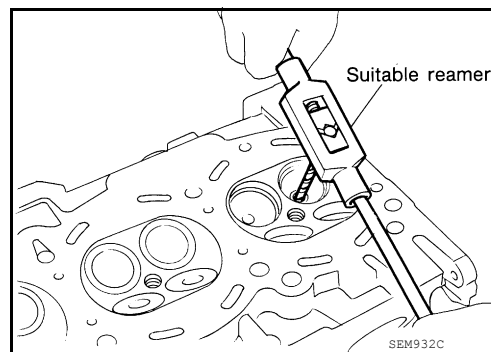

5. Press valve guide from camshaft side to dimensions as shown.

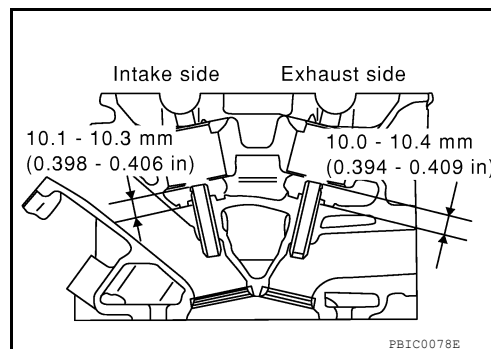

A
EM

C
D
E
F
G
H
I
J
K
L
M
N
O
P

CYLINDER HEAD

< REMOVAL AND INSTALLATION >

[QR25DE]

6. Apply finish to valve guide using suitable reamer.

Intake and exhaust : 6.000 - 6.018 mm (0.2362 - 0.2369 in)

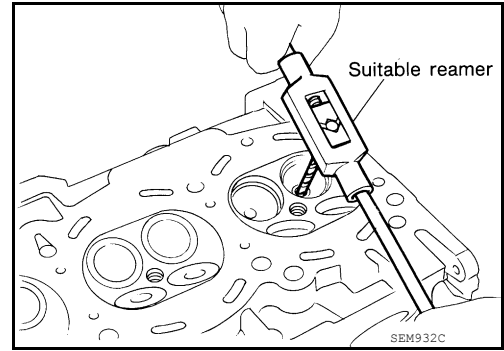

VALVE SEAT CONTACT

NOTE:

After confirming that the dimensions of valve guides and valves are within specifications, perform this procedure:

- Apply prussian blue (or white lead) onto contacting surface of valve seat to check the condition of the valve contact on the seat surface.
- Check if the contact area band is continuous all around the circumference.
- If not, grind to adjust valve fitting and check again. If the contacting surface still has NG conditions even after the re-check, replace the valve seat.

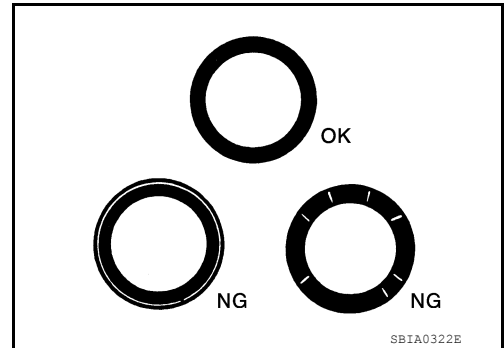

VALVE SEAT REPLACEMENT

NOTE:

When valve seat is removed, replace with an oversized [0.5 mm (0.020 in)] valve seat.

1. Bore out old seat until it collapses. Boring should not continue beyond the bottom face of the seat recess in the cylinder head. Set the machine depth stop to ensure this.
2. Ream cylinder head recess diameter for service valve seat.

Intake : 37.000 - 37.016 mm (1.4567 - 1.4573 in)
Exhaust : 32.000 - 32.016 mm (1.2598 - 1.2605 in)

- Be sure to ream in circles concentric to the valve guide center. This will enable the valve seat to fit correctly.

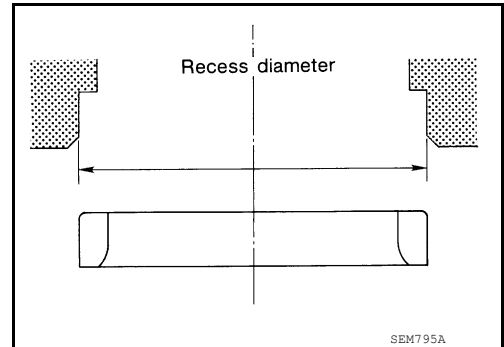

3. Heat cylinder head to 110° to 130°C (230° to 266°F) by soaking in heated oil.

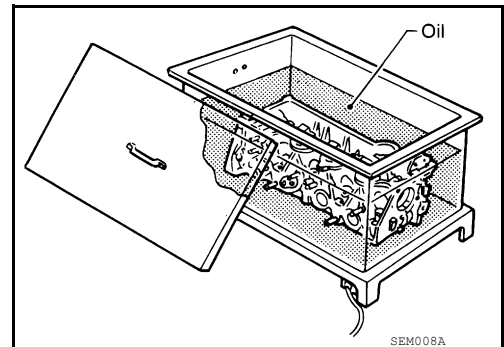

4. Use valve seats cooled well with dry ice. Force fit valve seat into cylinder head.

CAUTION:

Avoid directly touching the cold valve seats.

CYLINDER HEAD

< REMOVAL AND INSTALLATION >

[QR25DE]

5. Finish the seat to the specified dimensions using suitable tool. Refer to [EM-101, "Standard and Limit"](#).

CAUTION:

When using valve seat cutter, firmly grip the cutter handle with both hands. Then, press on the contacting surface all around the circumference to cut in a single drive. Improper pressure on the cutter or cutting many different times may result in a defective valve seat.

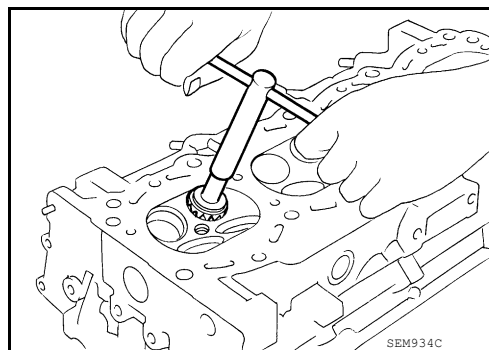

6. Using compound, grind to adjust valve fitting.
7. Check again for normal contact.

VALVE SPRING SQUARENESS

Set try square along the side of the valve spring and rotate the spring. Measure the maximum clearance between the top face of the spring and the try square.

Limit : Refer to [EM-101, "Standard and Limit"](#).

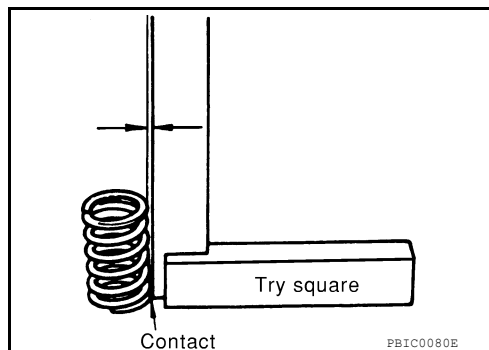

VALVE SPRING DIMENSIONS AND VALVE SPRING PRESSURE LOAD

Check valve spring pressure with valve spring seat installed at specified spring height. Replace if not within specifications.

CAUTION:

Do not remove the valve spring seat.

Dimension and pressure load : Refer to [EM-101, "Standard and Limit"](#).

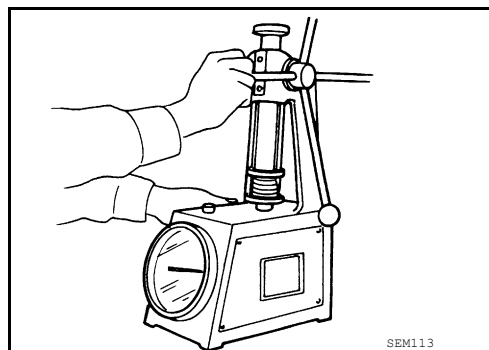

UNIT REMOVAL AND INSTALLATION

ENGINE ASSEMBLY

Removal and Installation

INFOID:000000007420252

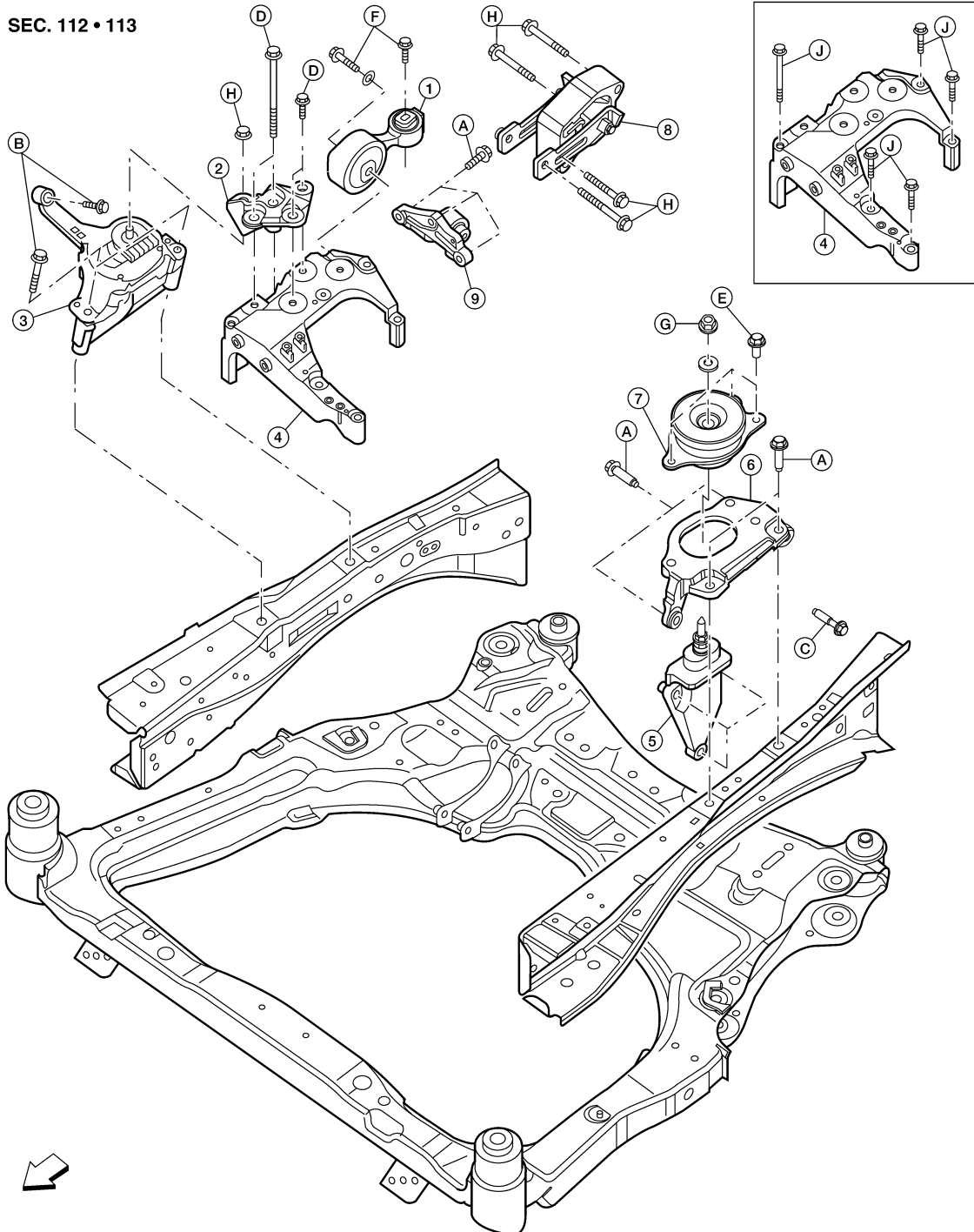

ALBIA05502Z

- | | | |
|---------------------------------|----------------------------------|---|
| 1. RH engine mount torque rod | 2. RH engine support bracket | 3. RH engine mounting insulator |
| 4. RH engine mounting bracket | 5. Transmission mounting bracket | 6. LH engine mounting bracket |
| 7. LH engine mounting insulator | 8. Rear engine mount torque rod | 9. Rear engine mount torque rod bracket |
| A. 40 N·m (4.1 kg·m, 30 ft·lb) | B. 41 N·m (4.2 kg·m, 30 ft·lb) | C. 45 N·m (4.6 kg·m, 33 ft·lb) |
| D. 50 N·m (5.1 kg·m, 37 ft·lb) | E. 60 N·m (6.1 kg·m, 44 ft·lb) | F. 85 N·m (8.7 kg·m, 63 ft·lb) |

ENGINE ASSEMBLY

< UNIT REMOVAL AND INSTALLATION >

[QR25DE]

G. 90 N·m (9.2 kg-m, 66 ft-lb)

H. 103 N·m (11 kg-m, 76 ft-lb)

J. Follow installation procedure

⇐ Front

A

WARNING:

- Place chocks at the front and back of the rear wheels.
- For engines not equipped with slingers, attach proper slingers and bolts as described in the parts catalog.

EM

CAUTION:

- Do not start working until the exhaust system and coolant are cool.
- If items or work required are not covered by the engine main body section, follow the applicable procedures.
- Use the correct supporting points for lifting and jacking. Refer to [GI-33, "Garage Jack and Safety Stand"](#).
- In removing the drive shaft, be careful not to damage the grease seals on the transaxle.

C

D

NOTE:

When removing components such as hoses, tubes/lines, etc., cap or plug openings to prevent fluid from spilling.

E

REMOVAL

1. Remove engine room cover.
2. Release fuel pressure. Refer to [EC-322, "Inspection"](#).
3. Disconnect the negative battery terminal. Refer to [PG-68, "Removal and Installation \(Battery\)"](#) (Coupe models) or [PG-140, "Removal and Installation \(Battery\)"](#) (Sedan models).
4. Disconnect the fuel rail at the fuel hose quick connector (engine side). Refer to [EM-26](#).
5. Drain the engine coolant. Refer to [CO-12, "Changing Engine Coolant"](#).
6. Remove the engine undercover. Refer to [EXT-16, "Removal and Installation - Coupe"](#) (Coupe models) or [EXT-40, "Removal and Installation"](#) (Sedan models).
7. Drain power steering fluid. Refer to [ST-8, "Draining"](#).
8. Remove hood assembly. Refer to [DLK-444, "HOOD ASSEMBLY : Removal and Installation"](#).
9. Remove the air duct and air cleaner case assembly. Refer to [EM-25, "Removal and Installation"](#).
10. Remove battery tray. Refer to [PG-69, "Removal and Installation \(Battery Tray\)"](#) (Coupe models) or [PG-141, "Removal and Installation \(Battery Tray\)"](#) (Sedan models).
11. Disconnect the ECM.
12. Remove the ECM bracket.
13. Remove cowl top. Refer to [EXT-21, "Removal and Installation"](#) (Coupe models) or [EXT-45, "Removal and Installation"](#) (Sedan models).
14. Remove strut tower brace. Refer to [FSU-14, "Exploded View"](#).
15. Disconnect EVAP hose and vacuum hose from intake manifold.
16. Disconnect and set aside the IPDM/ER and remove the IPDM/ER bracket. Refer to [PCS-45, "Removal and Installation"](#).
17. Remove upper and lower radiator hoses (engine side).
18. Disconnect CVT cooler lines (CVT models).
19. Disconnect the heater hoses.
20. Remove front LH and RH wheels and tires. Refer to [WT-68, "Adjustment"](#).
21. Remove the fender protector side covers (RH) and (LH). Refer to [EXT-22, "Removal and Installation"](#) (Coupe models) or [EXT-46, "Removal and Installation"](#) (Sedan models).

F

G

H

I

J

K

L

M

N

O

P

ENGINE ASSEMBLY

[QR25DE]

< UNIT REMOVAL AND INSTALLATION >

22. Remove the lower side bolt of the lower steering shaft assembly.
23. Remove rear cover plate.
24. Remove the torque converter nuts (CVT models).
25. Remove the rear engine mount torque rod.
26. Remove front exhaust tube. Refer to [EX-6, "Exploded View"](#).
27. Remove the LH and RH drive shafts. Refer to [FAX-10, "Removal and Installation \(Left Side\)"](#); [FAX-12, "Removal and Installation \(Right Side\)"](#).
28. Remove the drive belt. Refer to [EM-16, "Removal and Installation"](#).
29. Remove the front suspension member. Refer to [FSU-15, "Removal and Installation"](#).
30. Dismount the A/C compressor with piping connected and secure with wire to the radiator support.
31. Disconnect the power steering hose and tube from the power steering gear.
32. Disconnect the clutch operating cylinder fluid line (M/T models). Refer to [CL-12, "Removal and Installation"](#).
33. Disconnect the transaxle shift controls.
34. Disconnect electrical connectors from transaxle (M/T models).
35. Install engine slingers into front left cylinder head (A) and rear right cylinder head (B).
 - Use generator bracket bolt holes for the front slinger.
 - Use the proper slingers and bolts as described in the Parts Catalog.

Slinger bolts - front : 48 N·m (4.9 kg-m, 35 ft-lb)

Slinger bolts - rear : 28 N·m (2.8 kg-m, 21 ft-lb)

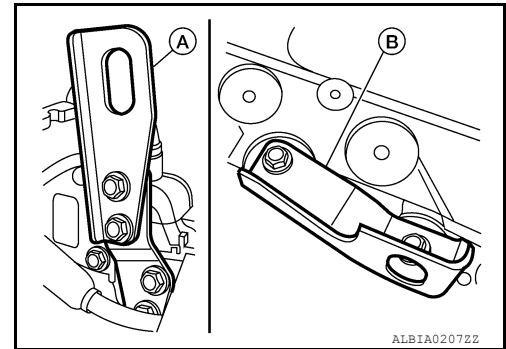
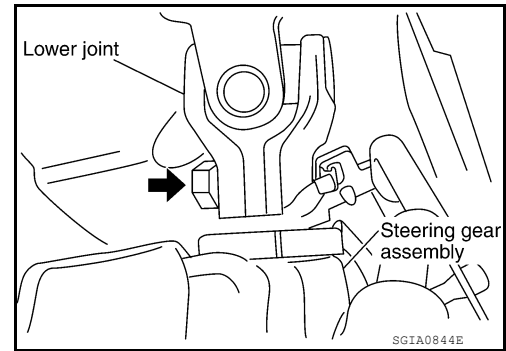

36. Support engine and transaxle assembly with engine lifting equipment from the top with the vehicle raised on a hoist.

CAUTION:

Put a piece of wood or something similar as the supporting surface, secure a completely stable condition.

37. Remove the RH engine mount torque rod, RH engine support bracket and RH engine mounting insulator and bracket.
38. Remove LH transaxle mounting insulator through-bolts.
39. Lower the engine and transaxle assembly from the engine compartment using suitable tool.

CAUTION:

- Before and during this procedure, always check if any harnesses are left connected.
- Avoid any damage to, or any oil/grease smearing or spills onto the engine mounting insulators.

40. Remove the starter motor. Refer to [STR-30, "Removal and Installation"](#) (M/T models), [STR-30, "Removal and Installation"](#) (CVT models).
41. Separate engine and transaxle. Refer to [TM-29, "Exploded View"](#) (M/T models), [TM-420, "Exploded View"](#) (CVT models).

INSTALLATION

Installation is in the reverse order of removal.

NOTE:

Tighten the transmission mounting bolts to specification. Refer to [TM-29, "Removal and Installation"](#) (M/T models), [TM-420, "Removal and Installation"](#) (CVT models).

- Do not allow oil to get on mounting insulators. Be careful not to damage mounting insulators.

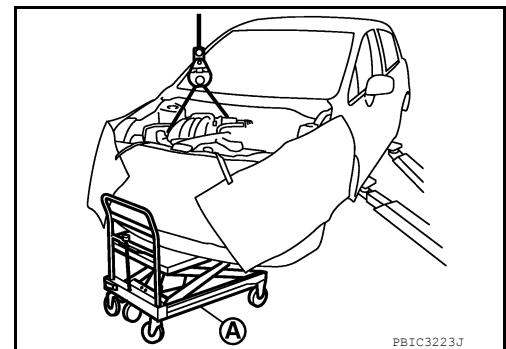

ENGINE ASSEMBLY

[QR25DE]

< UNIT REMOVAL AND INSTALLATION >

- If parts have a direction mark (arrow) this indicates front of the vehicle, and the parts must be installed according to the identification mark.
- Install the RH engine mounting bracket bolts in the following steps:
 - First install bolts (A) and (B) loosely.
 - Install and tighten the five RH engine mounting bracket bolts to specification in the order as shown.

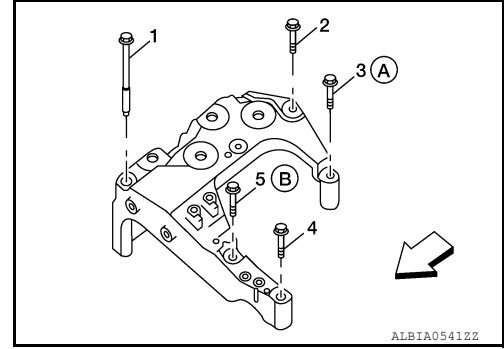

RH engine mounting bracket bolt : 48.2 N·m (4.9 kg-m, 36 ft-lb)

- ⇐: Front

INSPECTION AFTER INSTALLATION

- Before starting engine, check oil/fluid levels including engine coolant and engine oil. If less than required quantity, fill to the specified level. Refer to [MA-12. "Fluids and Lubricants"](#).
- Use procedure below to check for fuel leakage.
- Turn ignition switch ON (with engine stopped). With fuel pressure applied to fuel piping, check for fuel leakage at connection points.
- Start engine. With engine speed increased, check again for fuel leakage at connection points.
- Run engine to check for unusual noise and vibration.

NOTE:

- If hydraulic pressure inside timing chain tensioner drops after removal and installation, slack in the guide may generate a pounding noise during and just after engine start. However, this is normal. Noise will stop after hydraulic pressure rises.
- Warm up engine thoroughly to make sure there is no leakage of fuel, exhaust gas, or any oils/fluids including engine oil and engine coolant.
- Bleed air from passages in lines and hoses, such as in cooling system.
- After cooling down engine, again check oil/fluid levels including engine oil and engine coolant. Refill to specified level, if necessary.
- Summary of the inspection items:

Item		Before starting engine	Engine running	After engine stopped
Engine coolant		Level	Leakage	Level
Engine oil		Level	Leakage	Level
Transmission/ transaxle fluid	A/T and CVT Models	Leakage	Level/Leakage	Leakage
	M/T Models	Level/Leakage	Leakage	Level/Leakage
Other oils and fluids*		Level	Leakage	Level
Fuel		Leakage	Leakage	Leakage
Exhaust gas		—	Leakage	—

*Power steering fluid, brake fluid, etc.

CYLINDER BLOCK

< UNIT DISASSEMBLY AND ASSEMBLY >

[QR25DE]

UNIT DISASSEMBLY AND ASSEMBLY

CYLINDER BLOCK

Disassembly and Assembly

INFOID:000000007420253

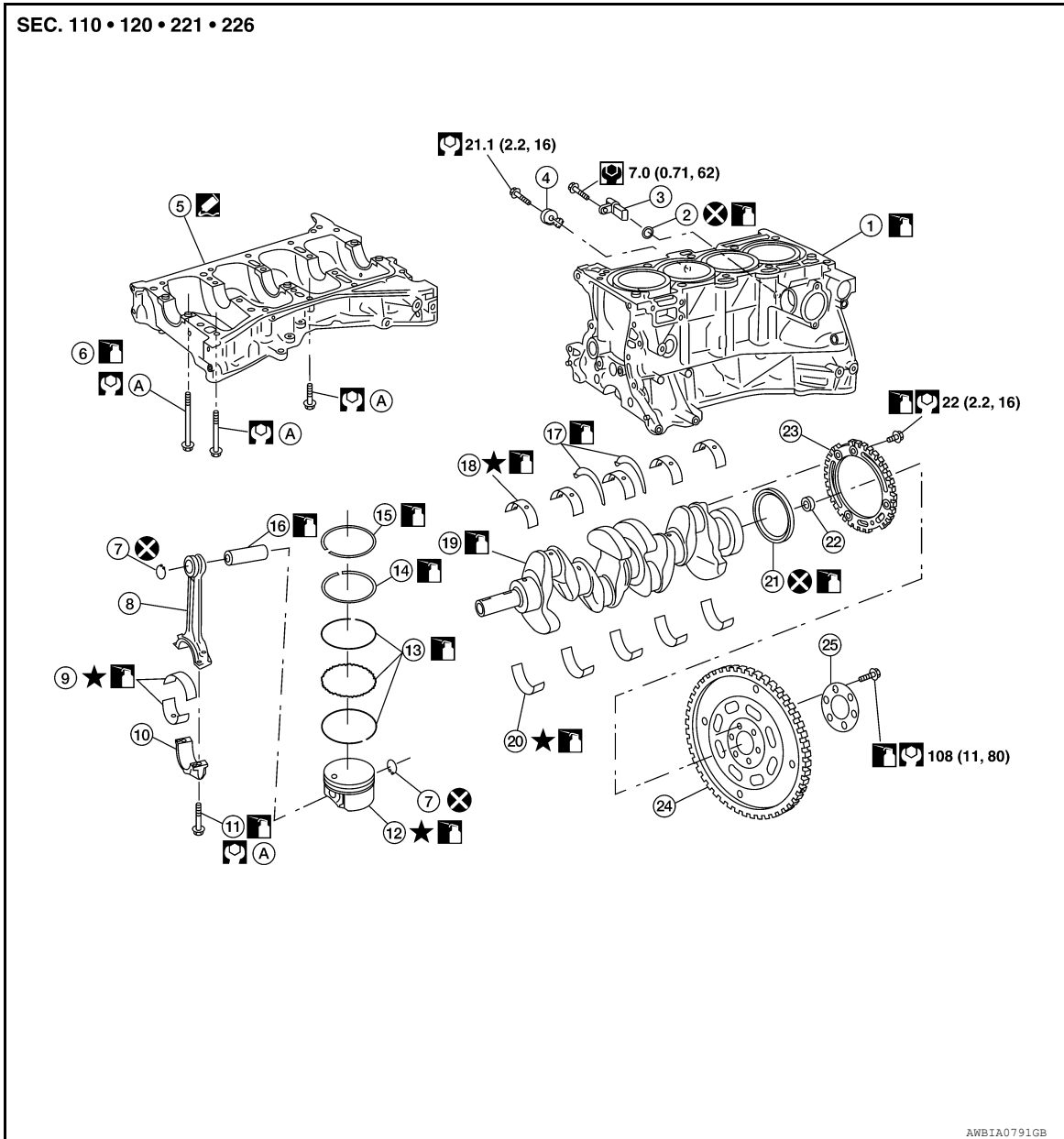

- | | | |
|--------------------------------------|-------------------------------------|---|
| 1. Cylinder block | 2. O-ring | 3. Crankshaft position sensor (POS) |
| 4. Knock sensor | 5. Lower cylinder block | 6. Lower cylinder block bolt |
| 7. Snap ring | 8. Connecting rod | 9. Connecting rod bearing |
| 10. Connecting rod bearing cap | 11. Connecting rod bearing cap bolt | 12. Piston |
| 13. Oil ring | 14. Second ring | 15. Top ring |
| 16. Piston pin | 17. Main thrust bearing | 18. Main bearing upper |
| 19. Crankshaft | 20. Main bearing lower | 21. Crankshaft rear oil seal |
| 22. Pilot converter | 23. Crankshaft signal plate | 24. Drive plate (CVT models), Flywheel (M/T models) |
| 25. Reinforcement plate (CVT models) | A. Follow assembly procedure | |

CYLINDER BLOCK

< UNIT DISASSEMBLY AND ASSEMBLY >

[QR25DE]

CAUTION:

Apply new engine oil to parts marked in illustration before installation.

DISASSEMBLY

1. Remove the engine and transaxle as an assembly from the vehicle, and separate the transaxle from the engine. Refer to [EM-74, "Removal and Installation"](#).

2. Remove the flywheel (M/T models) or drive plate (CVT models). Hold the crankshaft with a stopper plate and use a suitable tool to remove the bolts.

CAUTION:

- Be careful not to damage the flywheel contact surface for the clutch disc.

NOTE:

- The flywheel two-block construction allows movement in response to transmission side pressure, or when twisted in its rotational direction, therefore, some amount of noise is normal.

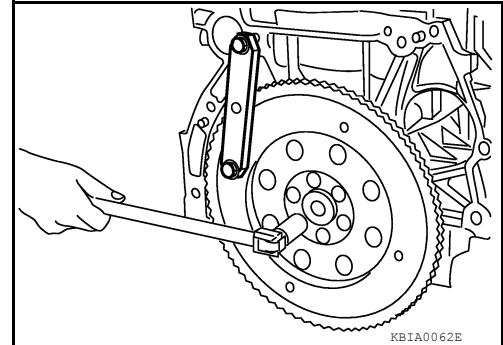

3. Remove pilot converter using Tool (CVT models).

Tool Number : ST16610001 (J-23907)

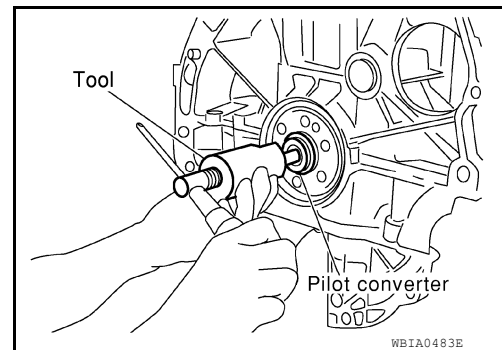

4. Mount the engine on a suitable engine stand.
5. Drain any remaining engine oil and coolant from the engine.
6. Remove the following components and associated parts.
 - Exhaust manifold and three way catalyst assembly. Refer to [EM-30, "Removal and Installation"](#).
 - Intake manifold collector. Refer to [EM-26, "Removal and Installation"](#).
 - Intake manifold and fuel tube assembly. Refer to [EM-26, "Removal and Installation"](#).
 - Ignition coils. Refer to [EM-36, "Removal and Installation"](#).
 - Rocker cover. Refer to [EM-40, "Removal and Installation"](#).
 - Front cover, timing chain, and balancer unit. Refer to [EM-54, "Removal and Installation"](#).
 - Cylinder head. Refer to [EM-66, "Removal and Installation"](#).

7. Remove the knock sensor.

CAUTION:

Carefully handle the sensor and do not drop the sensor.

8. Remove crankshaft position sensor (POS).

CAUTION:

- Avoid impacts such as a dropping.
- Do not disassemble.
- Keep it away from metal particles.
- Do not place sensor close to magnetic materials.

CYLINDER BLOCK

< UNIT DISASSEMBLY AND ASSEMBLY >

[QR25DE]

9. Remove the piston and connecting rod assemblies.
 - a. Position the crankshaft and corresponding connecting rod, to be removed, to the bottom dead center stroke.
 - b. Remove the connecting rod cap. Number the cap so it can be assembled in the same position.
 - c. Using a hammer handle or similar tool, push the piston and connecting rod assembly out of the top of the cylinder block. Number the piston and rod so it can be assembled in the same position.
 - Before removing the piston and connecting rod assembly, check the connecting rod side clearance. Refer to [EM-86, "Inspection After Disassembly"](#).

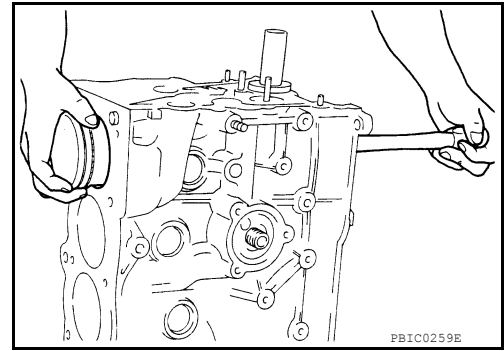

10. Remove the connecting rod bearings. If reusing, number them so they can be assembled in the same position and direction.

CAUTION:

- **When removing them, note the installation position. Keep them in the correct order.**

11. Remove the piston rings from the piston.
 - Use a piston ring expander.
 - Before removing the piston rings, check the piston ring side clearance. Refer to [EM-86, "Inspection After Disassembly"](#).

CAUTION:

- **When removing the piston rings, be careful not to damage the piston.**
- **Be careful not to damage piston rings by expanding them excessively, if reusing them.**

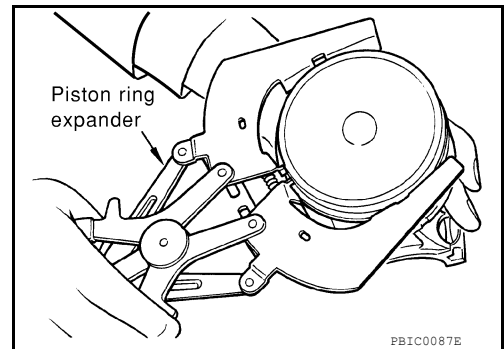

12. Remove the piston from the connecting rod as follows.

- a. Using a snap ring pliers, remove the two snap rings.

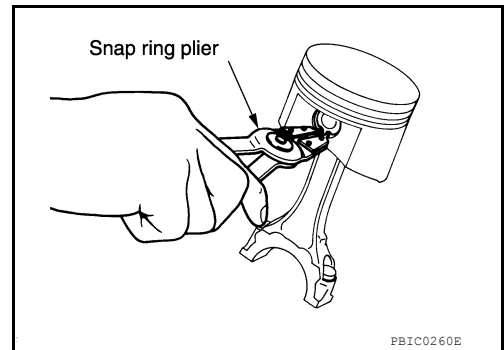

- b. Heat the piston to 60° - 70°C (140° - 158°F) with a heat gun, or equivalent.

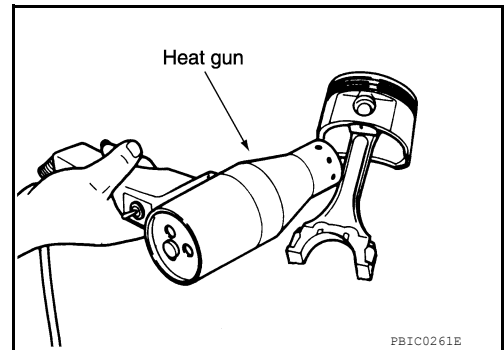

CYLINDER BLOCK

< UNIT DISASSEMBLY AND ASSEMBLY >

[QR25DE]

- c. Push out piston pin with a punch of an outer diameter of approximately 19 mm (0.75 in).

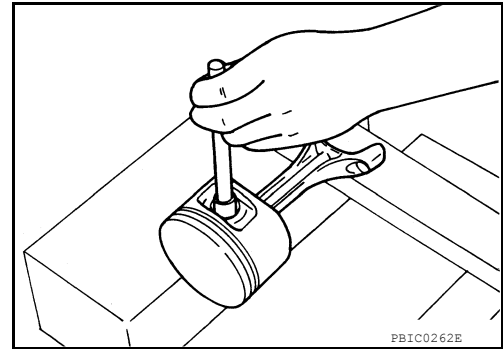

13. Remove the lower cylinder block bolts.
- Before loosening the lower cylinder block bolts, measure the crankshaft side clearance. Refer to [EM-86, "Inspection After Disassembly"](#).
 - Loosen the lower cylinder block bolts in the order as shown to remove them.

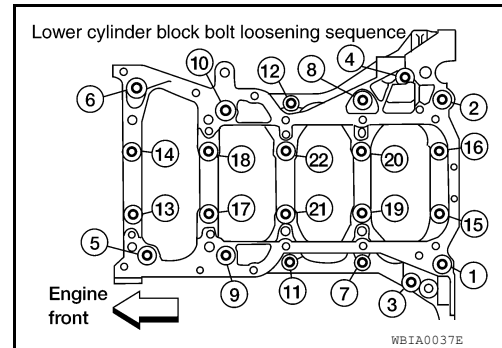

14. Remove the lower cylinder block.
- Cut the Silicone RTV Sealant and remove the lower cylinder block from the cylinder block, using Tool.

Tool number : KV10111100 (J-37228)

CAUTION:

Be careful not to damage the mating surface.

15. Remove the crankshaft.

CAUTION:

- Do not damage or deform the signal plate while mounted on the crankshaft.
- When setting the crankshaft on a flat surface, use a block of wood to avoid interference between the signal plate and the surface.
- Do not remove signal plate unless it is necessary.

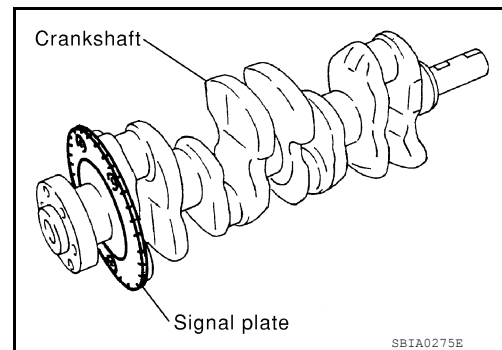

16. Pull the rear oil seal out of the rear end of the crankshaft.

CAUTION:

Do not to damage the crankshaft or cylinder block when removing the rear oil seal.

17. Remove the main bearings and thrust bearings from the cylinder block and lower cylinder block.

CAUTION:

Identify and number the bearings, if reusing them, so that they are assembled in the same position and direction.

ASSEMBLY

1. Using compressed air, clean out the coolant and oil passages in the cylinder block, the cylinder bore and the crankcase to remove any foreign material.

WARNING:

Use approved safety glasses to protect your eyes.

CYLINDER BLOCK

[QR25DE]

< UNIT DISASSEMBLY AND ASSEMBLY >

2. Install the drain plugs on the cylinder block.
 - Apply Silicone RTV Sealant.
Use Genuine Silicone RTV Sealant, or equivalent. Refer to [GI-15, "Recommended Chemical Products and Sealants"](#).
 -  Front

CAUTION:
Do not reuse copper sealing washers.

Drain plug torque

Drain plug (A) : 54 Nm (5.5 kg-m, 40 ft-lb)

Drain plug (B) : 9.8 Nm (1.0 kg-m, 80 in-lb)

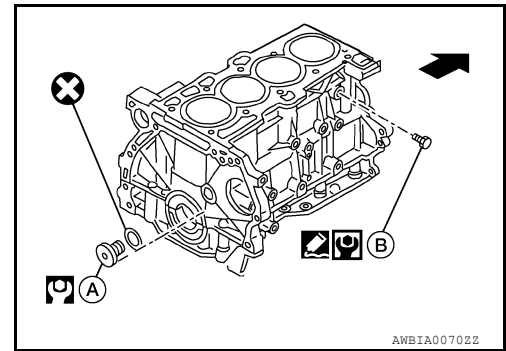

3. Install the main bearings and the thrust bearings.
 - a. Remove dust, dirt, and oil from the bearing mating surfaces of the cylinder block and lower cylinder block.
 - b. Install the thrust bearings to both sides of the No. 3 main bearing journal on the cylinder block.
 - Install the thrust bearings with the oil groove facing the crankshaft arm (outside).

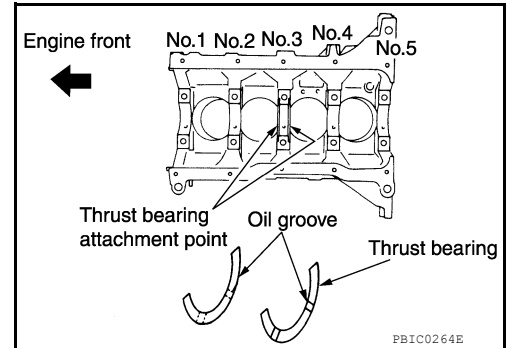

- c. Install the main bearings paying attention to their position and direction.
 - The main bearing with an oil hole and groove goes on the cylinder block side (A). The one without them goes on the lower cylinder block side (B).
 - Only the main bearing (on the cylinder block side) for No. 3 journal (6) has different specifications.
 - Before installing the bearings, apply engine oil to the bearing friction surface (inside). Do not apply oil to the back surface, but thoroughly clean it.
 - When installing, align the bearing stopper (1), (5) to the notch.
 - Make sure that the oil holes on the cylinder block and those on the corresponding bearing (2), (4) are aligned.

(3) : Journal other than No. 3
(7) : Thrust bearings

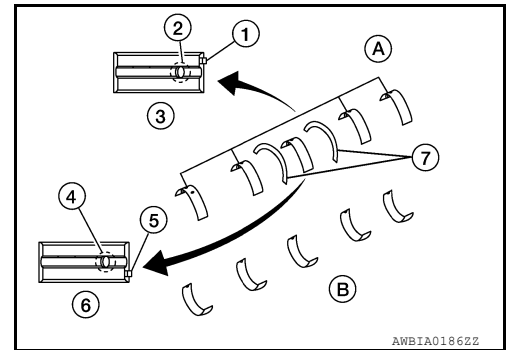

4. Install the signal plate to the crankshaft.
 - a. Position the crankshaft and signal plate using a positioning dowel pin, and tighten the bolts to specification.
 - b. Remove the dowel pin.
CAUTION:
Be sure to remove dowel pin before installing the crankshaft.

NOTE:
Dowel pins for the crankshaft and signal plate are supplied as a set for each.
5. Install the crankshaft onto the cylinder block.
 - While turning the crankshaft by hand, check that it turns smoothly.

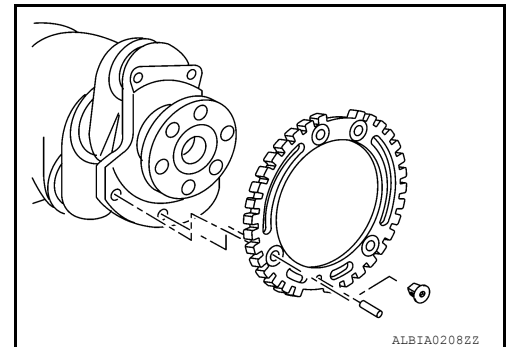

CYLINDER BLOCK

< UNIT DISASSEMBLY AND ASSEMBLY >

[QR25DE]

6. Install the lower cylinder block.
- Apply Silicone RTV Sealant to positions as shown.
 - Use Genuine Silicone RTV Sealant, or equivalent. Refer to [GL-15. "Recommended Chemical Products and Sealants"](#).

Dimension (A) : 3.5 - 4.5 mm (0.138 - 0.177 in)

Dimension (B) : Apply to end

CAUTION:

After the Silicone RTV Sealant is applied, the lower cylinder block installation must be finished within 5 minutes.

NOTE:

Cylinder block and lower cylinder block are machined together. Neither of them can be replaced separately.

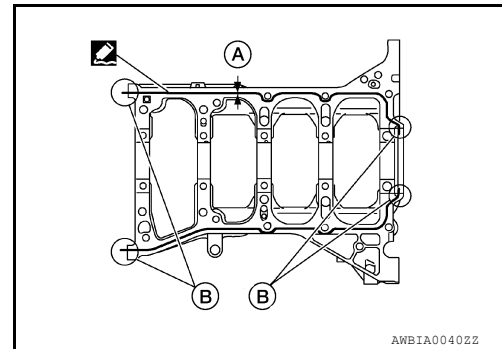

7. Tighten lower cylinder block bolts in the numerical order as shown and according to the following steps:

- a. Apply new engine oil to threads and seat surfaces of the bolts.
b. Tighten bolts No. 11 - 22 only in the order as shown, to specification below.

Step 1, bolts 11 - 22 only : 25.1 N·m (2.6 kg-m, 19 ft-lb)

- c. Tighten bolts No. 1 - 10 only in the order as shown, to specification below.

Step 2, bolts 1 - 10 only : 39.2 N·m (4.0 kg-m, 29 ft-lb)

- d. Tighten bolts No. 1 - 10 only in the order as shown, to specification below.

Step 3, bolts 1 - 10 only : 60° degrees rotation

Tool number : KV10112100 (BT-8653-A)

CAUTION:

Check tightening angle. Do not make judgment by visual inspection.

- Wipe off completely any protruding Silicone RTV Sealant on rear oil seal installation surface and the exterior of engine.
- Check crankshaft side clearance. Refer to [EM-86. "Inspection After Disassembly"](#).
- After installing the bolts, make sure that the crankshaft can be rotated smoothly by hand.

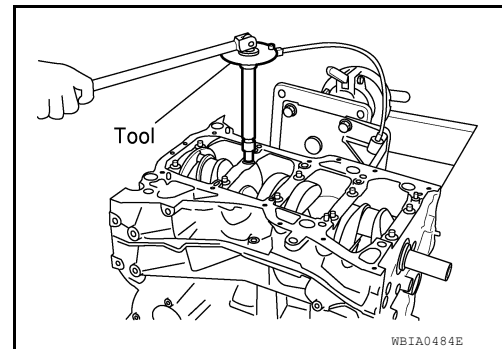
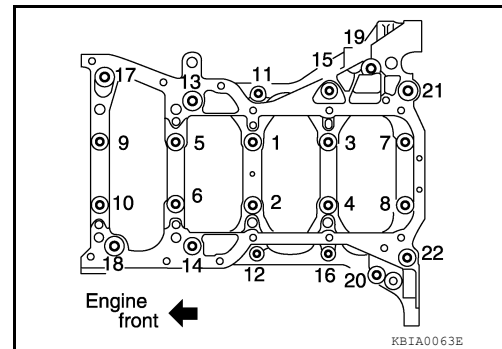

8. Install the rear oil seal.
- Press the oil seal between cylinder block and crankshaft with a suitable drift.
 - Be careful not to touch the grease on the oil seal lip.
 - Be careful not to cause scratches or burrs when pressing in the rear oil seal.

CAUTION:

Do not reuse rear oil seal.

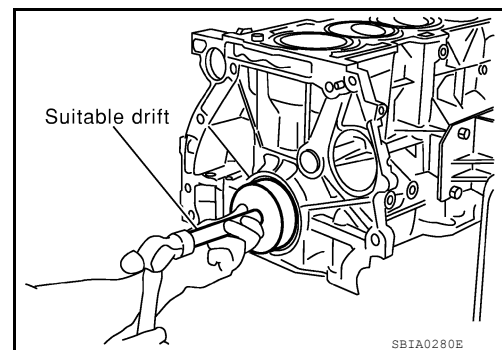

CYLINDER BLOCK

< UNIT DISASSEMBLY AND ASSEMBLY >

[QR25DE]

- Press in rear oil seal to the position as shown.

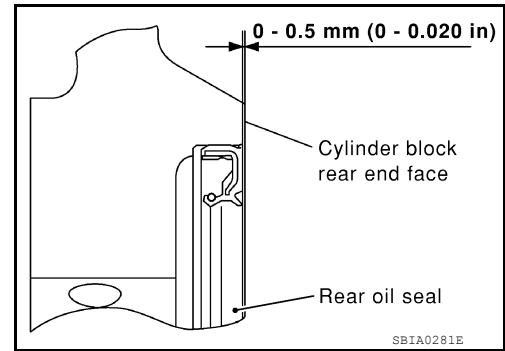

9. Install the piston to the connecting rod. Assemble the components in their original positions.
 - a. Using a snap ring pliers, install the snap ring to the grooves of the piston's rear side.
 - Insert the piston pin snap ring fully into groove.
 - b. Install the piston to the connecting rod.
 - Using a heat gun, heat the piston [approximately 60° - 70 C° (140° - 158 °F)] until the piston pin can be pushed in by hand without excessive force. From the front to the rear, insert the piston pin into the piston and the connecting rod.
 - Assemble so that the front mark on the piston crown and the oil holes and the cylinder No. on the connecting rod are positioned as shown.
 - c. Install the piston pin snap ring into the front of the piston.
 - Check that the connecting rod moves smoothly.

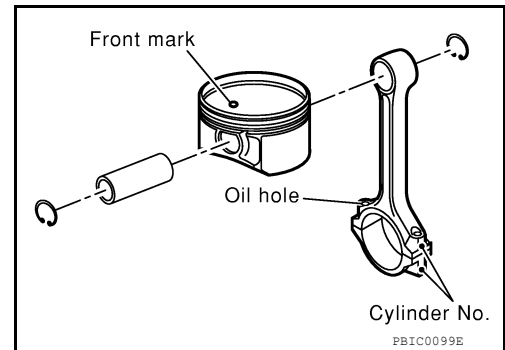

10. Using a piston ring expander, install the piston rings. Assemble the components in their original positions.

CAUTION:

Be careful not to damage the piston.

- Position each ring with the gap as shown, referencing the piston front mark as the starting point.
- Install the top ring and the second ring with the stamped surface facing upward.

Stamped mark : 1K (top ring)
: 2K (second ring)

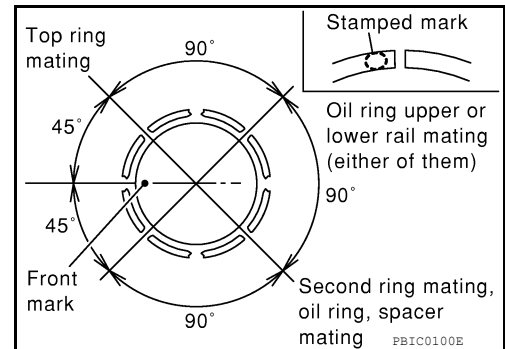

11. Install the connecting rod bearings to the connecting rod and the connecting rod cap. Assemble the components in their original positions.

- When installing the connecting rod bearings, apply engine oil to the bearing friction surface (inside). Do not apply oil to the back surface, but thoroughly clean the back.
- When installing, align the connecting rod bearing stopper protrusion with the notch of the connecting rod to install.
- Check the oil holes on the connecting rod and those on the corresponding bearing are aligned.

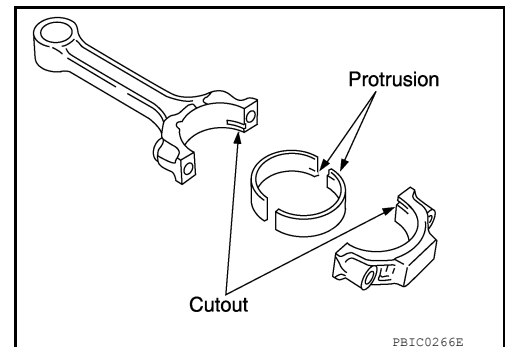

CYLINDER BLOCK

< UNIT DISASSEMBLY AND ASSEMBLY >

[QR25DE]

12. Install the piston and connecting rod assembly using Tool. Assemble the components in their original positions.

Tool number : EM03470000 (J-8037)

- Rotate the crankshaft so the pin corresponding to the connecting rod to be installed is at the bottom dead center position.
- Apply engine oil sufficiently to the cylinder bore, piston, and crankshaft pin.
- Match the cylinder position number with the cylinder No. on the connecting rod for installation.
- Install the piston with the front mark on the piston crown facing the front of the engine using Tool.

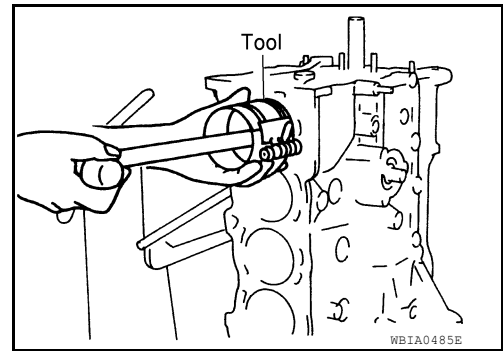

CAUTION:

Be careful not to damage the crankshaft pin, resulting from an interference of the connecting rod big end.

13. Install the connecting rod caps. Assemble the components in their original positions.
- Match the stamped cylinder number marks on the connecting rod with those on the cap to install.

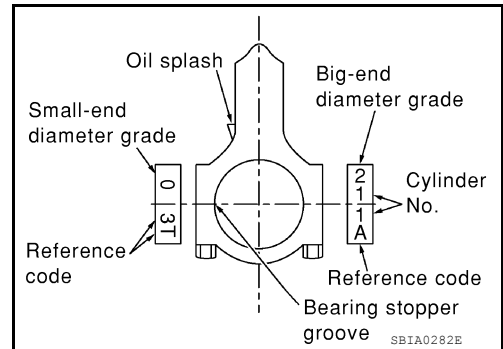

14. Tighten the connecting rod bolts using Tool as follows: Apply engine oil to the threads and seats of the connecting rod bolts.

CAUTION:

Check tightening angle. Do not make judgment by visual inspection.

Tool number : KV10112100 (BT-8653-A)

- Step 1 : 29.4 N·m (3.0 kg-m, 22 ft-lb)**
- Step 2 : 0 N·m**
- Step 3 : 19.6 N·m (2.0 kg-m, 14 lb-ft)**
- Step 4 : Rotate bolts 90° + 0.5°**

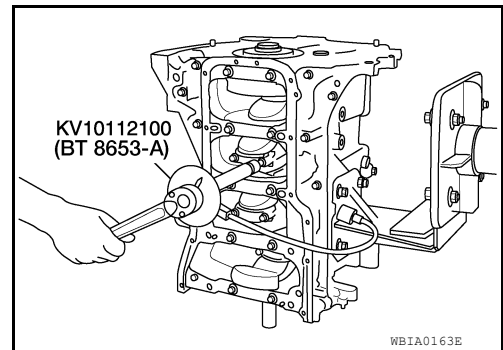

- Check the connecting rod side clearance. Refer to [EM-86. "Inspection After Disassembly"](#).
- After tightening the bolts, make sure that the crankshaft rotates smoothly.

15. Install flywheel (M/T Models), or drive plate (CVT Models).
- Install drive plate, reinforcement plate and pilot converter as shown.
 - Using a drift with 33 mm (1.30 in) diameter, push pilot converter into the end of the crankshaft.

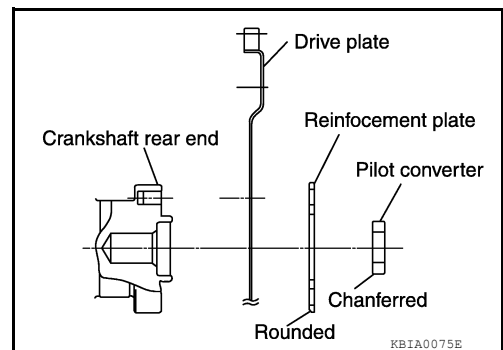

CYLINDER BLOCK

< UNIT DISASSEMBLY AND ASSEMBLY >

[QR25DE]

16. Install the knock sensor.
- Make sure that there is no foreign material on the cylinder block mating surface and the back surface of the knock sensor.
 - Install the knock sensor with the connector facing lower left by 45° as shown.
 - Do not tighten the bolts while holding the connector.
 - Make sure that the knock sensor does not interfere with other parts.

CAUTION:

If the knock sensor is dropped, replace it with new one.

17. Install the crankshaft position sensor (POS).
18. Installation of remaining components is in the reverse order of removal.

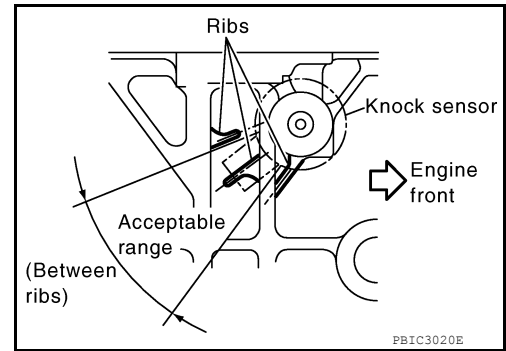

Inspection After Disassembly

INFOID:000000007420254

CRANKSHAFT FREE END PLAY

- Using a dial gauge, measure the free end play between the thrust bearings and the crankshaft arm when the crankshaft is moved fully forward or backward.

Standard : 0.10 - 0.26 mm (0.0039 - 0.0102 in)

Limit : 0.30 mm (0.0118 in)

- If the measured value exceeds the limit, replace the thrust bearings, and measure again. If it still exceeds the limit, replace the crankshaft.

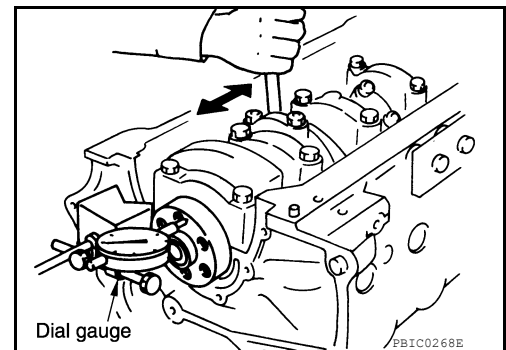

CONNECTING ROD SIDE CLEARANCE

- Measure side clearance between connecting rod and crankshaft arm using a feeler gauge.

Standard : 0.20 - 0.35 mm (0.0079 - 0.0138 in)

Limit : 0.50 mm (0.0197 in)

- If the measured value exceeds the limit, replace the connecting rod bearings, and measure again. If it still exceeds the limit, replace the crankshaft also.

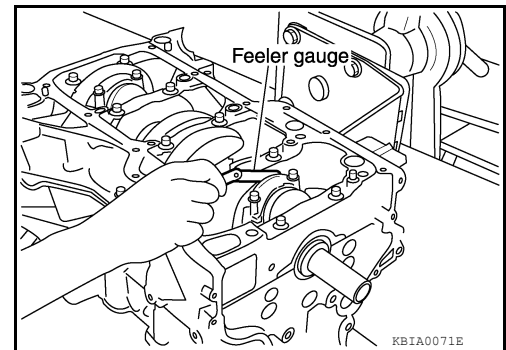

PISTON AND PISTON PIN CLEARANCE

Diameter of Piston Pin Bore

- Measure the diameter of piston pin bore using an inside micrometer. Refer to [EM-101, "Standard and Limit"](#).

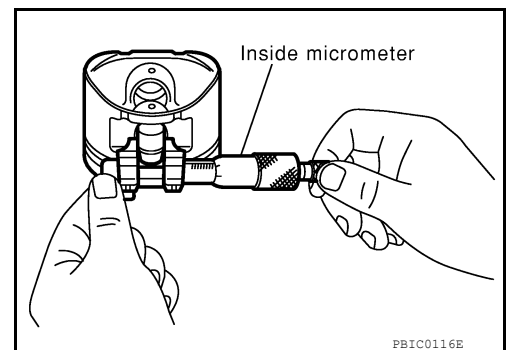

Outer Diameter of Piston Pin

CYLINDER BLOCK

< UNIT DISASSEMBLY AND ASSEMBLY >

[QR25DE]

- Measure outer diameter of piston pin using a micrometer. Refer to [EM-101, "Standard and Limit"](#).

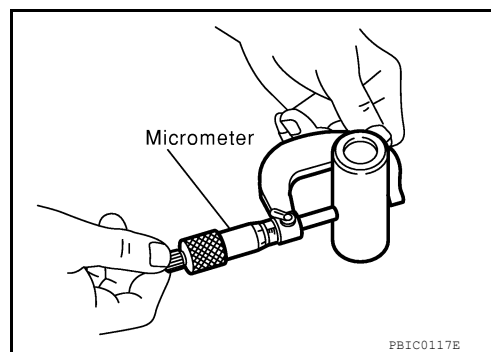

Piston to Piston Pin Clearance

(Piston pin clearance) = (Piston pin bore diameter) – (Outer diameter of piston pin)

- A: Front mark
- B: Piston pin bore grade
- C: Piston grade I.D. stamp
- D: Piston crown I.D. code stamp

Standard : 0.002 - 0.006 mm (0.0001 - 0.0002 in)

- If clearance exceeds specification, replace either or both of piston/piston pin assembly and connecting rod assembly with reference to specification of each parts.
- Use the piston selection table to replace piston/piston pin assembly. Refer to [EM-95, "How to Select Piston and Bearing"](#).
- Use the connecting rod bearing selection table to replace connecting rod. Refer to [EM-95, "How to Select Piston and Bearing"](#).

NOTE:

- The connecting rod small end grade and piston pin hole (piston pin) grade are provided only for the parts installed at the plant. For service parts, no grades can be selected. Only 0 grade is available.
- Follow the "CONNECTING ROD BUSHING OIL CLEARANCE (SMALL END)" procedure for the values for each grade at the plant.

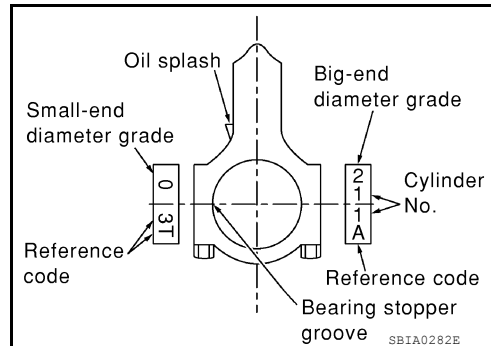
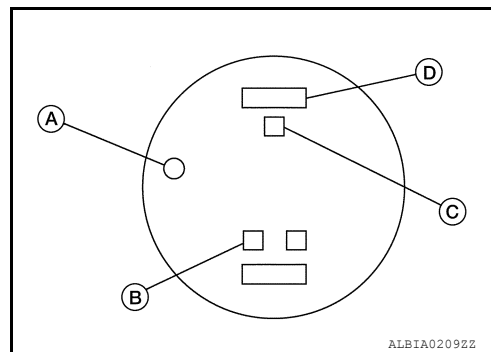

PISTON RING SIDE CLEARANCE

- Measure side clearance of piston ring and piston ring groove using a feeler gauge. Refer to [EM-101, "Standard and Limit"](#).
- If out of specification, replace piston and/or piston ring assembly.

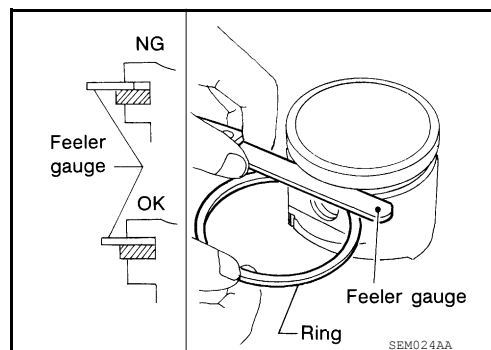

PISTON RING END GAP

CYLINDER BLOCK

[QR25DE]

< UNIT DISASSEMBLY AND ASSEMBLY >

- Check if inner diameter of cylinder bore is within specification. Follow the "PISTON TO CYLINDER BORE CLEARANCE" procedure.
- Insert piston ring until middle of cylinder with piston, and measure gap using a feeler gauge. Refer to [EM-101, "Standard and Limit"](#).
- If out of specification, replace piston ring.

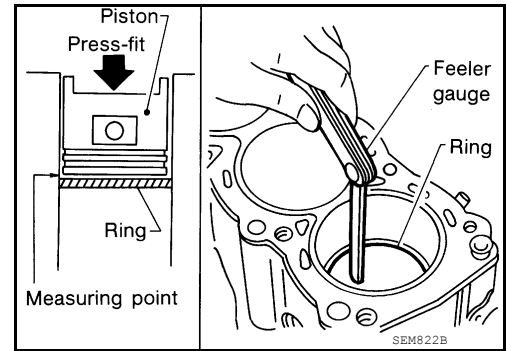

CONNECTING ROD BEND AND TORSION

- Check with connecting rod aligner. Refer to [EM-101, "Standard and Limit"](#).

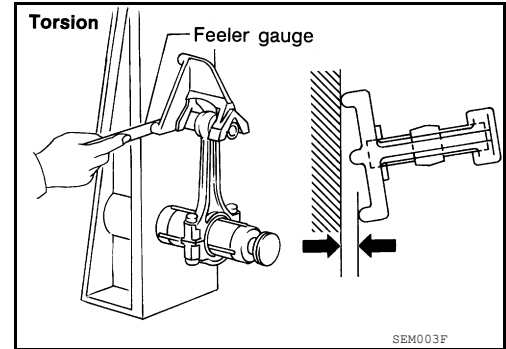

- If it exceeds the limit, replace connecting rod assembly.

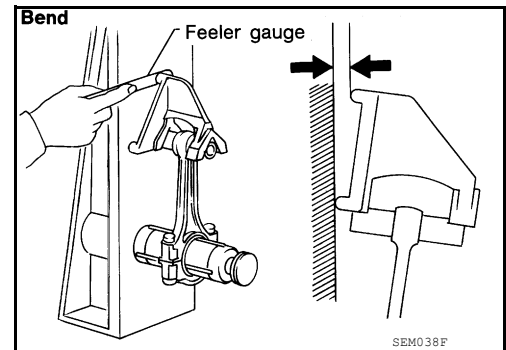

CONNECTING ROD BEARING (BIG END)

- Install the connecting rod cap without the connecting rod bearing installed. After tightening the connecting rod bolt to the specified torque, measure the connecting rod big end inner diameter using an inside micrometer. Refer to [EM-101, "Standard and Limit"](#).

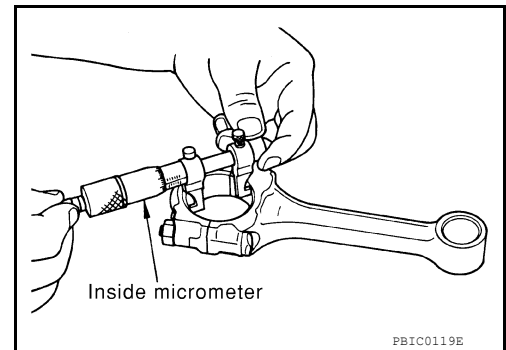

CONNECTING ROD BUSHING OIL CLEARANCE (SMALL END)

Inner Diameter of Connecting Rod (Small End)

CYLINDER BLOCK

< UNIT DISASSEMBLY AND ASSEMBLY >

[QR25DE]

- Measure inner diameter of bushing. Refer to [EM-101, "Standard and Limit"](#)

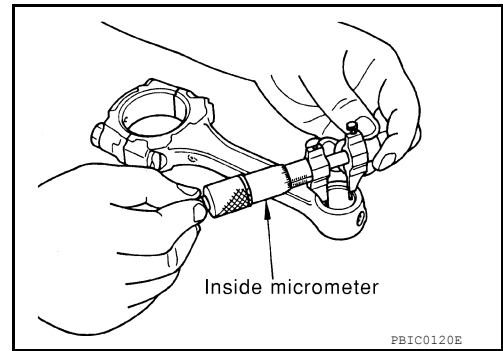

Outer Diameter of Piston Pin

- Measure outer diameter of piston pin. Refer to [EM-101, "Standard and Limit"](#).

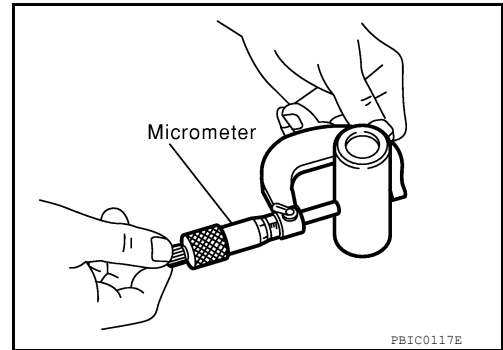

Piston Pin to Connecting Rod Bushing Clearance (Small End)
 (Piston pin to connecting rod bushing clearance (small end)) = (Inner diameter of connecting rod small end) – (Outer diameter of piston pin)

Standard : 0.005 - 0.017 mm (0.0002 - 0.0007 in)

- If the measured value exceeds the standard, replace the connecting rod assembly and/or piston and piston pin assembly.
- If replacing the piston and piston pin assembly, use the "Piston Selection Table" to select the piston corresponding to the applicable bore grade of the cylinder block to be used. Refer to [EM-95, "How to Select Piston and Bearing"](#).

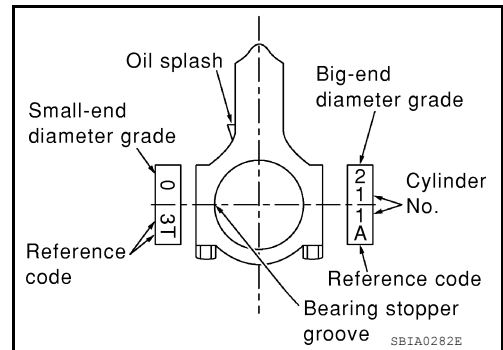

Factory Installed Parts Grading:

- Service parts apply only to grade 0 (B).

Piston Pin Grade (B)	Unit: mm (in)	
	0	1
Connecting rod small end inner bushing diameter	20.000 - 20.006 (0.7874 - 0.7876)	20.006 - 20.012 (0.7876 - 0.7879)
Piston pin outer diameter	19.989 - 19.995 (0.7870 - 0.7872)	19.995 - 20.001 (0.7872 - 0.7874)
Piston pin bore diameter	19.993 - 19.999 (0.7871 - 0.7874)	19.999 - 20.005 (0.7874 - 0.7876)

- A: Front mark
- C: Piston grade I.D. stamp
- D: Piston crown I.D. code stamp

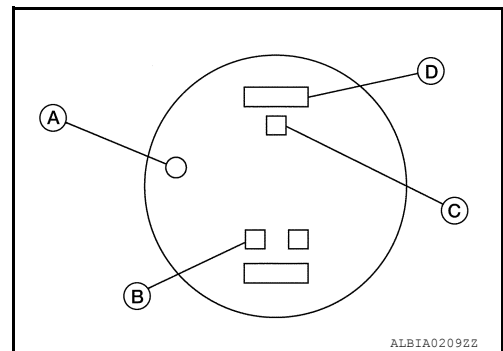

CYLINDER BLOCK DISTORTION

- Using a scraper, remove gasket on the cylinder block surface, and also remove oil, scale, carbon, or other contamination.

CAUTION:

Be careful not to allow gasket debris to enter the oil or coolant passages.

CYLINDER BLOCK

[QR25DE]

< UNIT DISASSEMBLY AND ASSEMBLY >

- Measure the distortion on the block upper face at some different points in 6 directions.

Limit : 0.1 mm (0.004 in)

- If out of the distortion limit, replace the cylinder block and lower block they are machined together as an assembly.

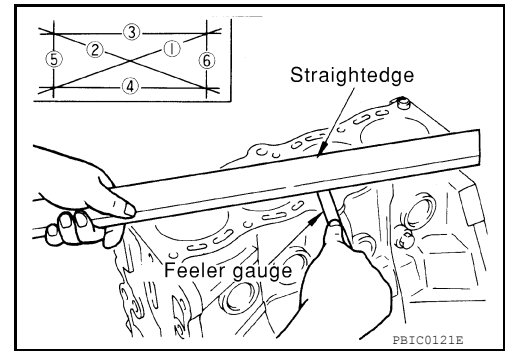

INNER DIAMETER OF MAIN BEARING HOUSING

- Install the main bearing caps with the main bearings removed and tighten the bolts to the specified torque. Refer to [EM-78, "Disassembly and Assembly"](#).
- Using a bore gauge, measure the inner diameter of the main bearing housing.

Standard : 58.944 - 58.968 mm (2.3206 - 2.3216 in)

- If out of the standard, replace the cylinder block and lower cylinder block assembly.

NOTE:

These components cannot be replaced as a single unit because they are machined together as an assembly.

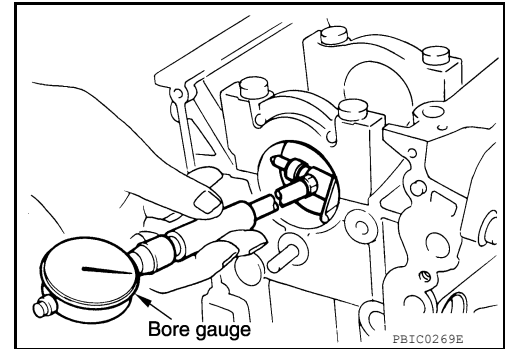

PISTON TO CYLINDER BORE CLEARANCE

Inner Diameter of Cylinder Bore

- Using a bore gauge, measure cylinder bore for wear, out-of-round and taper at 6 different points on each cylinder. [(X and Y) directions at (A), (B) and (C)]. The (Y) axis is in the longitudinal direction of the engine.

NOTE:

When determining cylinder bore grade, measure cylinder bore at (B) position. Refer to [EM-101, "Standard and Limit"](#).

- If there are scratches and/or seizure on the cylinder inner wall, hone the inner wall.

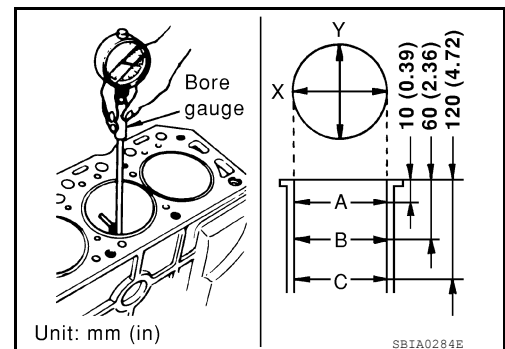

Outer Diameter of Piston

- Measure piston skirt diameter using a micrometer. Refer to [EM-101, "Standard and Limit"](#).
- Measure point (distance from the top): 37.5 mm (1.476 in)

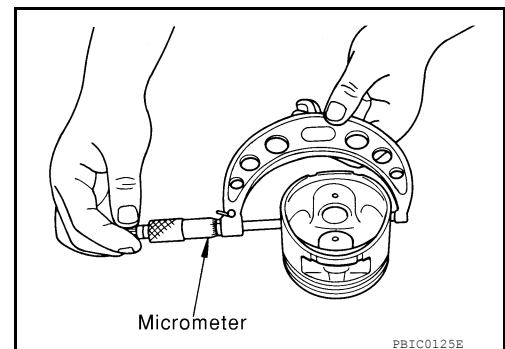

Piston to Cylinder Bore Clearance

- Calculate by outer diameter of piston skirt and inner diameter of cylinder (direction X, position B).
(Clearance) = (Inner diameter of cylinder) – (Outer diameter of piston skirt).

Standard : 0.010 - 0.030 mm (0.0004 - 0.0012 in)

Limit : 0.08 mm (0.0031 in)

CYLINDER BLOCK

< UNIT DISASSEMBLY AND ASSEMBLY >

[QR25DE]

- If it exceeds the limit, replace piston/piston pin assembly.

Reboring Cylinder Bore

1. Cylinder bore size is determined by adding piston-to-bore clearance to piston diameter (A).

Rebored size calculation: $D = A + B - C$

D: Bored diameter

A: Piston diameter as measured

B: Piston-to-bore clearance (standard value)

C: Honing allowance 0.02 mm (0.0008 in)

2. Install lower cylinder block, and tighten to the specified torque. Otherwise, cylinder bores may be distorted in final assembly.
3. Cut cylinder bores.
 - **When any cylinder needs boring, all other cylinders must also be bored.**
 - **Do not cut too much out of cylinder bore at a time. Cut only 0.05 mm (0.0020 in) or so in diameter at a time.**
4. Hone cylinders to obtain specified piston-to-bore clearance.
5. Measure finished cylinder bore for out-of-round and taper.
 - **Measurement should be done after cylinder bore cools down.**

OUTER DIAMETER OF CRANKSHAFT JOURNAL

- Measure outer diameter of crankshaft journals.

Standard : 54.955 - 54.979 mm (2.1636 - 2.1645 in)

OUTER DIAMETER OF CRANKSHAFT PIN

- Measure outer diameter of crankshaft pin.

Standard : 44.956 - 44.974 mm (1.7699 - 1.7706 in)

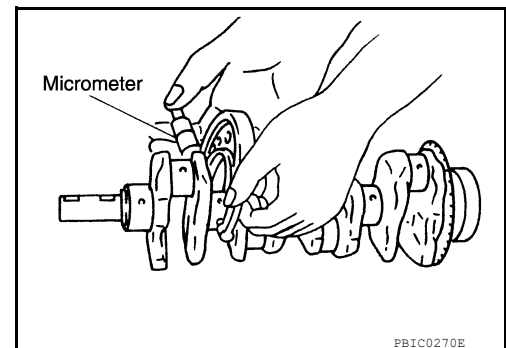

OUT-OF-ROUND AND TAPER OF CRANKSHAFT

- Measure the dimensions at four different points as shown on each journal and pin using a micrometer.
- Out-of-round is indicated by the difference in dimensions between (X) and (Y) at (A) and (B).
- Taper is indicated by the difference in dimension between (A) and (B) at (X) and (Y).

Standard

Out-of-round (X - Y) : 0.005 mm (0.0002 in)

Taper (A - B) : 0.005 mm (0.0002 in)

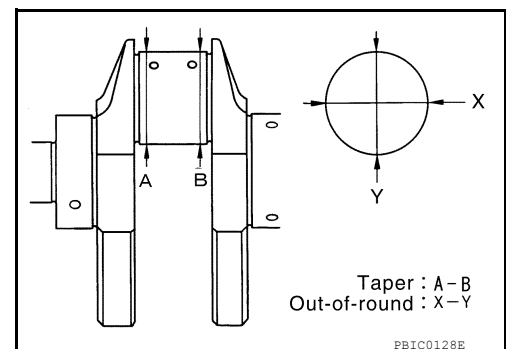

CRANKSHAFT RUNOUT

CYLINDER BLOCK

[QR25DE]

< UNIT DISASSEMBLY AND ASSEMBLY >

- Place a V-block on a precise flat table to support the journals on both ends of the crankshaft.
- Place a dial gauge straight up on the No. 3 journal.
- While rotating the crankshaft, read the movement of the pointer on the dial gauge, the total indicator runout reading.

Limit : **Less than 0.05 mm (0.002 in)**

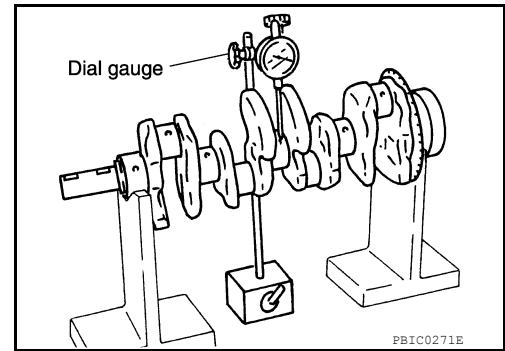

OIL CLEARANCE OF CONNECTING ROD BEARING

Method of Measurement

- Install the connecting rod bearings to the connecting rod and the cap, and tighten the connecting rod bolts to the specified torque. Using an inside micrometer measure the inner diameter of connecting rod bearing.
(Oil clearance) = (Inner diameter of connecting rod bearing) – (Outer diameter of crankshaft pin)

Standard : **0.035 - 0.045 mm (0.0014 - 0.0018 in)**

Limit : **0.10 mm (0.0039 in)**

- If clearance cannot be adjusted within the standard, grind crankshaft pin and use undersized bearing. Refer to [EM-95. "How to Select Piston and Bearing"](#).

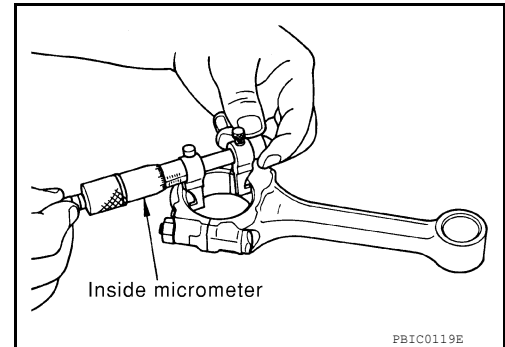

Method of Using Plastigage

- Remove oil and dust on the crankshaft pin and the surfaces of each bearing completely.
- Cut the Plastigage slightly shorter than the bearing width, and place it in crankshaft axial direction, avoiding oil holes.
- Install the connecting rod bearings to the connecting rod cap, and tighten the connecting rod bolts to the specified torque.

CAUTION:

Do not rotate the crankshaft.

- Remove the connecting rod cap and bearings, and using the scale on the Plastigage bag, measure the Plastigage width.

NOTE:

The procedure when the measured value exceeds the limit is same as that described in the method by calculation.

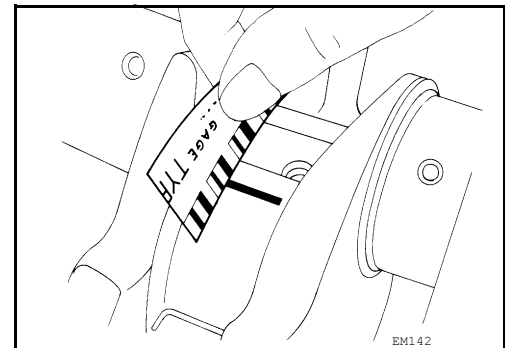

OIL CLEARANCE OF MAIN BEARING

Method of Measurement

- Install the main bearings to the cylinder block and bearing cap. Measure the main bearing inner diameter with the bearing cap bolt tightened to the specified torque.
(Oil clearance) = (Inner diameter of main bearing) – (Outer diameter of crankshaft journal)

Standard:

No. 1, 3, and 5 journals : **0.012 - 0.022 mm (0.0005 - 0.0009 in)**

No. 2 and 4 journals : **0.018 - 0.028 mm (0.0007 - 0.0011 in)**

Limit : **0.1 mm (0.004 in)**

- If the measured value exceeds the limit, select main bearings referring to the main bearing inner diameter and crankshaft journal outer diameter, so that the oil clearance satisfies the standard. Refer to [EM-95. "How to Select Piston and Bearing"](#).

Method of Using Plastigage

CYLINDER BLOCK

< UNIT DISASSEMBLY AND ASSEMBLY >

[QR25DE]

- Remove oil and dust on the crankshaft journal and the surfaces of each bearing completely.
- Cut the Plastigage slightly shorter than the bearing width, and place it in crankshaft axial direction, avoiding oil holes.
- Tighten the main bearing bolts to the specified torque.

CAUTION:

Do not rotate the crankshaft.

- Remove the bearing cap and bearings, and using the scale on the plastigage bag, measure the plastigage width.

NOTE:

The procedure when the measured value exceeds the limit is same as that described in the "Method by Calculation".

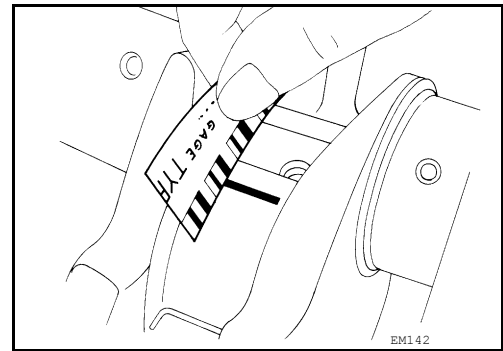

A

EM

C

D

CRUSH HEIGHT OF MAIN BEARING

- When the bearing cap is removed after being tightened to the specified torque with main bearings installed, the tip end of bearing must protrude.

Standard : There must be crush height.

- If the standard is not met, replace main bearings.

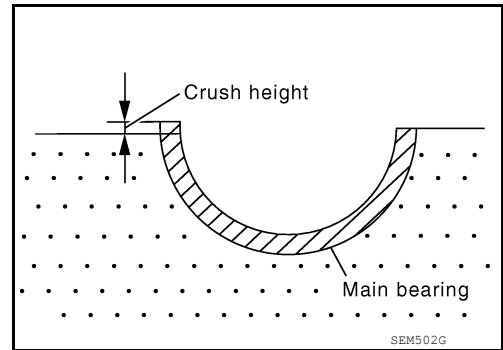

E

F

G

H

OUTER DIAMETER OF LOWER CYLINDER BLOCK BOLT

- Perform only with M10 (0.39 in) bolts.
- Measure outer diameters (d1, d2) at two positions as shown.
- Measure d2 at a point within area (A) as shown.
- When the value of d1- d2 exceeds the limit (a large difference in dimensions), replace the bolt with a new one.

Limit : 0.13 mm (0.0051 in)

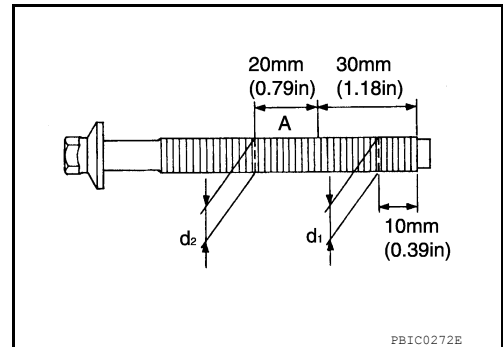

I

J

K

L

OUTER DIAMETER OF CONNECTING ROD BOLT

- Measure outer diameter (d) at position as shown.
- When "d" exceeds the limit (when it becomes thinner), replace the bolt with a new one.

Limit : 7.75 mm (0.3051 in) or less

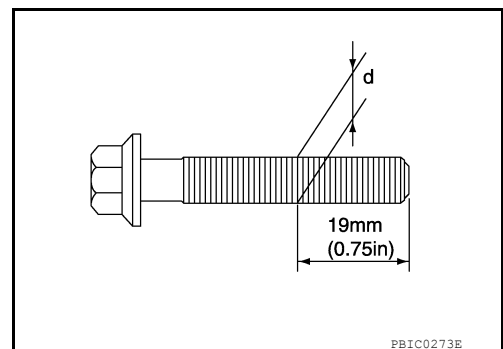

M

N

O

P

MOVEMENT AMOUNT OF FLYWHEEL (M/T MODEL)

NOTE:

- Inspection for double mass flywheel only.
- Do not disassemble double mass flywheel.

Flywheel Deflection

CYLINDER BLOCK

[QR25DE]

< UNIT DISASSEMBLY AND ASSEMBLY >

- Measure deflection of flywheel contact surface to the clutch with a dial gauge.
- Measure runout at 210 mm (8.27 in) dia.

Limit : 0.45 mm (0.0177 in) or less under no load

- Measure axial displacement at 250 mm (9.84 in) dia.

Limit : 1.3 mm (0.051 in) or less under 100N (10.2 kg-f, 22.5 lb-f) force

- When measured value exceeds the limit, replace the flywheel with a new one.

Movement Amount in Rotation Direction

- Check the movement amount in the following procedure.
1. Install a bolt to clutch cover hole, and place a torque wrench on the extended line of the flywheel center line.
 - Tighten bolt to keep it from loosening at the specification.

Bolt to clutch cover hole : 9.8 N·m (1 kg-m, 87 in-lb)

2. Put a mating mark on circumferences of the two flywheel masses without applying any load (measurement standard points).
3. Apply a force of 9.8 N·m (1 kg-m, 87 in-lb) in each direction, and mark the movement amount on the mass on the transmission side.
4. Measure dimensions of movement amounts (A) and (B) on circumference of the flywheel on the transmission side.

Standard : 35 mm (1.38 in) or less

- When measured value is outside the standard, replace flywheel.

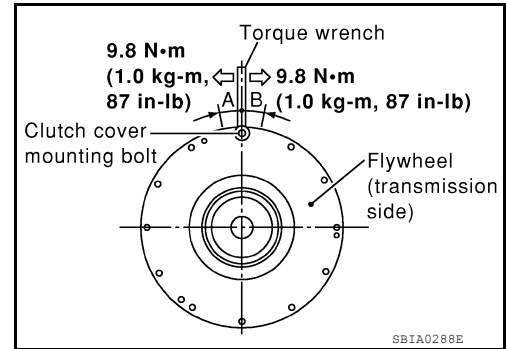
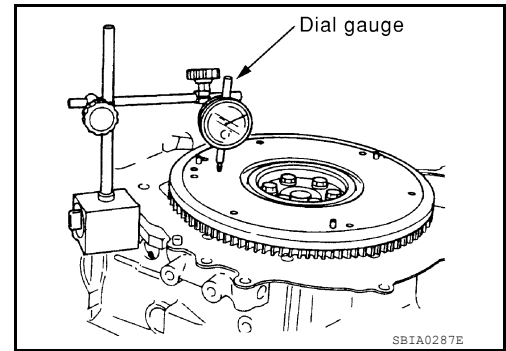

HOW TO SELECT PISTON AND BEARING

< UNIT DISASSEMBLY AND ASSEMBLY >

[QR25DE]

HOW TO SELECT PISTON AND BEARING

How to Select Piston and Bearing

INFOID:000000007420255

DESCRIPTION

Selection points	Selection parts	Selection items	Selection methods
Between cylinder block to crankshaft	Main bearing	Main bearing grade (bearing thickness)	Determined by match of cylinder block bearing housing grade (inner diameter of housing) and crankshaft journal grade (outer diameter of journal)
Between crankshaft to connecting rod	Connecting rod bearing	Connecting rod bearing grade (bearing thickness)	Combining service grades for connecting rod big end inner diameter and crankshaft pin outer diameter determine connecting rod bearing selection
Between cylinder block to piston	Piston and piston pin assembly (The piston is available together with piston pin as an assembly)	Piston grade (piston outer diameter)	Piston grade = cylinder bore grade (inner diameter of bore)
*Between piston to connecting rod	—	—	—

*For the service parts, the grade for fitting cannot be selected between a piston pin and a connecting rod. (Only 0 grade is available.) The information at the shipment from the plant is described as a reference.

- The identification grade stamped on each part is the grade for the dimension measured in new condition. This grade cannot apply to reused parts.
- For reused or repaired parts, measure the dimension accurately. Determine the grade by comparing the measurement with the values of each selection table.
- For details of the measurement method of each part, the reuse standards, and the selection method of the selective fitting parts, follow the applicable procedures.

HOW TO SELECT A PISTON

When New Cylinder Block is Used:

- Check the cylinder bore grade on rear left side of cylinder block, and select a piston of the same grade (C).
- A: Front mark
- B: Piston pin bore grade
- D: Piston crown I.D. code stamp

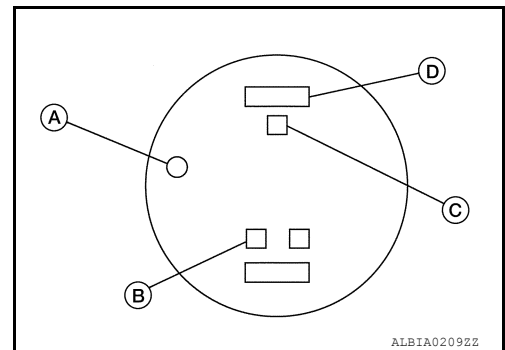

- If there is a corrected stamp mark on the cylinder block, use it as a correct reference.

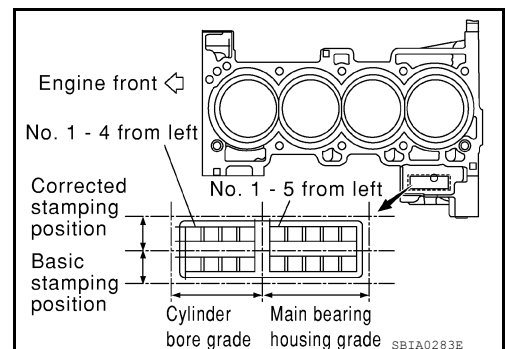

HOW TO SELECT PISTON AND BEARING

< UNIT DISASSEMBLY AND ASSEMBLY >

[QR25DE]

When a Cylinder Block is Reused:

1. Measure the cylinder block bore inner diameter.
2. Determine the bore grade by comparing the measurement with the values under the cylinder bore inner diameter of the "Piston Selection Table". Select the piston of the same grade.

Piston Selection Table

- For the piston selection table, refer to [EM-101. "Standard and Limit"](#).

NOTE:

- The piston is available together with piston pin as an assembly.
- The piston pin (piston pin bore) grade is provided only for the parts installed at the plant. For service parts, no grades can be selected. Only 0 grade is available.

HOW TO SELECT A CONNECTING ROD BEARING

When New Connecting Rod and Crankshaft are Used:

1. Apply big end inside diameter grade stamped on connecting rod side face to the row in the "Connecting Rod Bearing Selection Table".

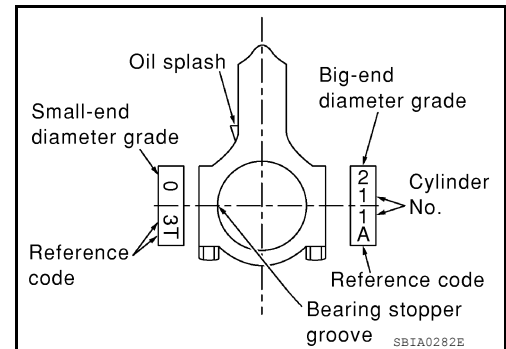

2. Apply pin diameter grade (B) stamped on crankshaft front side to the column in the "Connecting Rod Bearing Selection Table".
 - A: Journal diameter grade
3. Read the symbol at the cross point of selected row and column in the "Connecting Rod Bearing Selection Table".
4. Apply the symbol obtained to connecting rod bearing grade table to select.

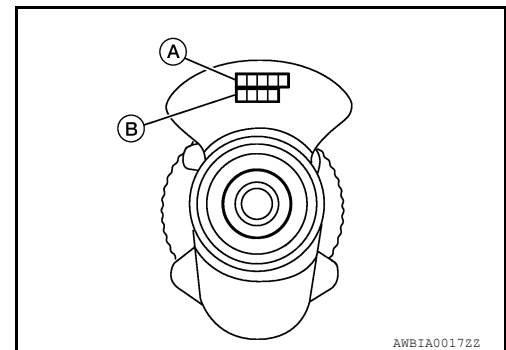

When Crankshaft and Connecting Rod are Reused:

1. Measure dimensions of the big end inner diameter of connecting rod and outer diameter of crankshaft pin individually.
2. Apply the dimension measured to the "Connecting Rod Bearing Selection Table" below.

HOW TO SELECT PISTON AND BEARING

< UNIT DISASSEMBLY AND ASSEMBLY >

[QR25DE]

Connecting Rod Bearing Selection Table

Mark	Outer diameter Unit: mm (in)	Connecting rod big end. inner diameter		Crankshaft pin outer diameter												
		Mark	Inner diameter Unit: mm (in)	0	1	2	3	4	5	6	7	8	9	A	B	C
				48.000 - 48.001 (1.8898 - 1.8898)	48.001 - 48.002 (1.8898 - 1.8898)	48.002 - 48.003 (1.8898 - 1.8899)	48.003 - 48.004 (1.8899 - 1.8899)	48.004 - 48.005 (1.8899 - 1.8900)	48.005 - 48.006 (1.8890 - 1.8900)	48.006 - 48.007 (1.8890 - 1.8900)	48.007 - 48.008 (1.8890 - 1.8901)	48.008 - 48.009 (1.8901 - 1.8901)	48.009 - 48.010 (1.8901 - 1.8902)	48.010 - 48.011 (1.8902 - 1.8902)	48.011 - 48.012 (1.8902 - 1.8902)	48.012 - 48.013 (1.8902 - 1.8903)
A	44.974 - 44.973 (1.7706 - 1.7706)	0	0	0	0	01	01	01	01	1	1	1	12	12	12	12
B	44.973 - 44.972 (1.7706 - 1.7705)	0	0	0	01	01	01	01	1	1	1	1	12	12	12	2
C	44.972 - 44.971 (1.7705 - 1.7705)	0	0	01	01	01	01	1	1	1	1	12	12	12	2	2
D	44.971 - 44.970 (1.7705 - 1.7705)	0	01	01	01	1	1	1	1	12	12	12	2	2	2	2
E	44.970 - 44.969 (1.7705 - 1.7704)	01	01	01	1	1	1	1	12	12	12	2	2	2	2	23
F	44.969 - 44.968 (1.7704 - 1.7704)	01	01	1	1	1	1	12	12	12	2	2	2	2	23	23
G	44.968 - 44.967 (1.7704 - 1.7704)	01	1	1	1	12	12	12	2	2	2	2	23	23	23	23
H	44.967 - 44.966 (1.7704 - 1.7703)	1	1	1	12	12	12	2	2	2	2	23	23	23	3	3
J	44.966 - 44.965 (1.7703 - 1.7703)	1	1	12	12	12	2	2	2	2	23	23	23	3	3	3
K	44.965 - 44.964 (1.7703 - 1.7702)	1	12	12	12	2	2	2	2	23	23	23	3	3	3	3
L	44.964 - 44.963 (1.7702 - 1.7702)	12	12	12	2	2	2	2	23	23	23	3	3	3	3	34
M	44.963 - 44.962 (1.7702 - 1.7702)	12	12	2	2	2	2	23	23	23	3	3	3	3	34	34
N	44.962 - 44.961 (1.7702 - 1.7701)	12	2	2	2	23	23	23	3	3	3	3	34	34	34	34
P	44.961 - 44.960 (1.7701 - 1.7701)	2	2	2	23	23	23	3	3	3	3	34	34	34	4	4
R	44.960 - 44.959 (1.7701 - 1.7700)	2	2	23	23	23	3	3	3	3	34	34	34	4	4	4
S	44.959 - 44.958 (1.7700 - 1.7700)	2	23	23	23	3	3	3	3	34	34	34	4	4	4	4
T	44.958 - 44.957 (1.7700 - 1.7700)	23	23	23	3	3	3	3	34	34	34	4	4	4	4	4
U	44.957 - 44.956 (1.7700 - 1.7699)	23	23	3	3	3	3	34	34	34	4	4	4	4	4	4

Connecting Rod Bearing Grade Table. Refer to [EM-101, "Standard and Limit"](#).

Undersize Bearing Usage Guide

- When the specified oil clearance is not obtained with standard size connecting rod bearing, use undersize (US) bearing.
- When using undersize bearing, measure the bearing inner diameter with bearing installed, and grind the crankshaft pin so that the oil clearance satisfies the standard.

Bearing Undersize Table

Unit: mm (in)	
Size U.S.	Thickness
0.25 (0.0098)	1.622 - 1.630 (0.0639 - 0.0642)

CAUTION:

In grinding the crankshaft pin to use undersize bearings, do not damage the fillet R (All crankshaft pins).

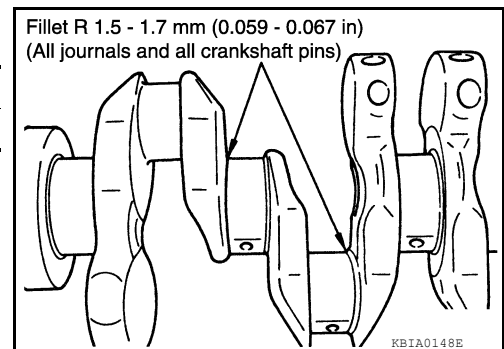

HOW TO SELECT A MAIN BEARING

When New Cylinder Block and Crankshaft are Used:

HOW TO SELECT PISTON AND BEARING

< UNIT DISASSEMBLY AND ASSEMBLY >

[QR25DE]

1. "Main Bearing Selection Table" rows correspond to bearing housing grade on rear left side of cylinder block.
 - If there is a corrected stamp mark on the cylinder block, use it as a correct reference.

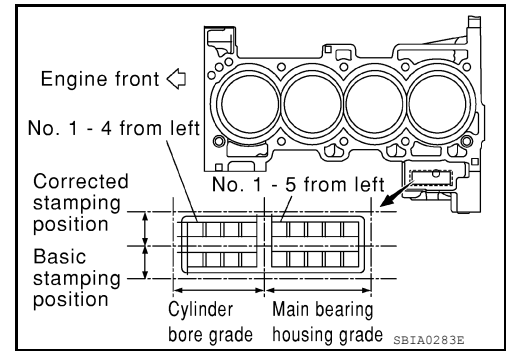

2. Apply journal diameter grade (A) stamped on crankshaft front side to column in "Main Bearing Selection Table".
 - Pin diameter grade (B)

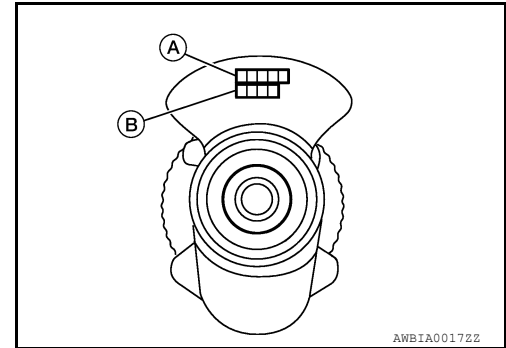

3. Find value at crossing of row and column in "Main Bearing Selection Table".

CAUTION:

 - There are two main bearing selection tables. One is for odd-numbered journals (1, 3, and 5) and the other is for even-numbered journals (2 and 4). Make certain to use the appropriate table. This is due to differences in the specified clearances.
4. Apply the symbol obtained to "Main Bearing Grade Table" to select.

NOTE:

 - Service parts are available as a set of both upper and lower.

When Cylinder Block and Crankshaft are Reused:

1. Measure inner diameter of cylinder block main bearing housing and outer diameter of crankshaft journal.
2. Apply measurement in above step 1 to the "Main Bearing Selection Table".
3. Follow steps 3 and 4 in "When New Cylinder Block and Crankshaft are Used".

HOW TO SELECT PISTON AND BEARING

< UNIT DISASSEMBLY AND ASSEMBLY >

[QR25DE]

Main Bearing Selection Table (No.1, 3, and No.5 journals)

Cylinder block main bearing housing inner diameter		Mark																									
		A	B	C	D	E	F	G	H	J	K	L	M	N	P	R	S	T	U	V	W	X	Y	4	7		
Crankshaft journal outer diameter	Outer diameter Unit: mm (in)	Inner diameter Unit: mm (in)																									
		58.944 - 58.945 (2.3206 - 2.3207)	58.945 - 58.946 (2.3207 - 2.3207)	58.946 - 58.947 (2.3207 - 2.3207)	58.947 - 58.948 (2.3207 - 2.3208)	58.948 - 58.949 (2.3208 - 2.3208)	58.949 - 58.950 (2.3208 - 2.3209)	58.950 - 58.951 (2.3209 - 2.3209)	58.951 - 58.952 (2.3209 - 2.3210)	58.952 - 58.953 (2.3209 - 2.3210)	58.953 - 58.954 (2.3210 - 2.3210)	58.954 - 58.955 (2.3210 - 2.3211)	58.955 - 58.956 (2.3211 - 2.3211)	58.956 - 58.957 (2.3211 - 2.3211)	58.957 - 58.958 (2.3212 - 2.3212)	58.958 - 58.959 (2.3212 - 2.3212)	58.959 - 58.960 (2.3212 - 2.3213)	58.960 - 58.961 (2.3213 - 2.3213)	58.961 - 58.962 (2.3213 - 2.3213)	58.962 - 58.963 (2.3213 - 2.3214)	58.963 - 58.964 (2.3214 - 2.3214)	58.964 - 58.965 (2.3214 - 2.3215)	58.965 - 58.966 (2.3215 - 2.3215)	58.966 - 58.967 (2.3215 - 2.3215)	58.967 - 58.968 (2.3215 - 2.3216)		
Mark	Outer diameter Unit: mm (in)																										
A	54.979 - 54.978 (2.1645 - 2.1645)	0	0	01	01	01	1	1	1	12	12	12	2	2	2	23	23	23	3	3	3	34	34	34	4	4	4
B	54.978 - 54.977 (2.1645 - 2.1644)	0	01	01	01	1	1	1	12	12	12	2	2	2	23	23	23	3	3	3	3	34	34	34	4	4	4
C	54.977 - 54.976 (2.1644 - 2.1644)	01	01	01	1	1	1	12	12	12	2	2	2	23	23	23	3	3	3	3	34	34	34	4	4	4	4
D	54.976 - 54.975 (2.1644 - 2.1644)	01	01	1	1	1	12	12	12	2	2	2	23	23	23	3	3	3	3	34	34	34	4	4	4	4	45
E	54.975 - 54.974 (2.1644 - 2.1643)	01	1	1	1	12	12	12	2	2	2	23	23	23	3	3	3	3	34	34	34	4	4	4	4	45	45
F	54.974 - 54.973 (2.1643 - 2.1643)	1	1	1	12	12	12	2	2	2	23	23	23	3	3	3	3	34	34	34	4	4	4	4	45	45	45
G	54.973 - 54.972 (2.1643 - 2.1642)	1	1	12	12	12	2	2	2	23	23	23	3	3	3	3	34	34	34	4	4	4	4	45	45	45	5
H	54.972 - 54.971 (2.1642 - 2.1642)	1	12	12	12	2	2	2	23	23	23	3	3	3	3	34	34	34	4	4	4	4	45	45	45	5	5
J	54.971 - 54.970 (2.1642 - 2.1642)	12	12	12	2	2	2	23	23	23	3	3	3	34	34	34	4	4	4	4	45	45	45	5	5	5	5
K	54.970 - 54.969 (2.1642 - 2.1641)	12	12	2	2	2	23	23	23	3	3	3	34	34	34	4	4	4	4	45	45	45	5	5	5	5	56
L	54.969 - 54.968 (2.1641 - 2.1641)	12	2	2	2	23	23	23	3	3	3	34	34	34	4	4	4	4	45	45	45	5	5	5	5	56	56
M	54.968 - 54.967 (2.1641 - 2.1641)	2	2	2	23	23	23	3	3	3	34	34	34	4	4	4	4	45	45	45	5	5	5	5	56	56	56
N	54.967 - 54.966 (2.1641 - 2.1640)	2	2	23	23	23	3	3	3	34	34	34	4	4	4	4	45	45	45	5	5	5	5	56	56	56	6
P	54.966 - 54.965 (2.1640 - 2.1640)	2	23	23	23	3	3	3	34	34	34	4	4	4	4	45	45	45	5	5	5	5	56	56	56	6	6
R	54.965 - 54.964 (2.1640 - 2.1639)	23	23	23	3	3	3	34	34	34	4	4	4	45	45	45	5	5	5	5	56	56	56	6	6	6	6
S	54.964 - 54.963 (2.1639 - 2.1639)	23	23	3	3	3	34	34	34	4	4	4	45	45	45	5	5	5	5	56	56	56	6	6	6	6	67
T	54.963 - 54.962 (2.1639 - 2.1639)	23	3	3	3	34	34	34	4	4	4	45	45	45	5	5	5	5	56	56	56	6	6	6	6	67	67
U	54.962 - 54.961 (2.1639 - 2.1638)	3	3	3	34	34	34	4	4	4	45	45	45	5	5	5	5	56	56	56	6	6	6	6	67	67	67
V	54.961 - 54.960 (2.1638 - 2.1638)	3	3	34	34	34	4	4	4	45	45	45	5	5	5	5	56	56	56	6	6	6	6	67	67	67	7
W	54.960 - 54.959 (2.1638 - 2.1637)	3	34	34	34	4	4	4	45	45	45	5	5	5	5	56	56	56	6	6	6	6	67	67	67	7	7
X	54.959 - 54.958 (2.1637 - 2.1637)	34	34	34	4	4	4	45	45	45	5	5	5	5	56	56	56	6	6	6	6	67	67	67	7	7	7
Y	54.958 - 54.957 (2.1637 - 2.1637)	34	34	4	4	4	45	45	45	5	5	5	5	56	56	56	6	6	6	6	67	67	67	7	7	7	7
4	54.957 - 54.956 (2.1637 - 2.1636)	34	4	4	4	45	45	45	5	5	5	5	56	56	56	6	6	6	6	67	67	67	7	7	7	7	7
7	54.956 - 54.955 (2.1636 - 2.1636)	4	4	4	45	45	45	5	5	5	5	56	56	56	6	6	6	6	67	67	67	7	7	7	7	7	7

KBIA0149E

A
EM
C
D
E
F
G
H
I
J
K
L
M
N
O
P

HOW TO SELECT PISTON AND BEARING

Main Bearing Selection Table (No.2,and 4 journals)

Cylinder block main bearing hausing inner diameter	Crankshaft journal outer diameter	Mark		A	B	C	D	E	F	G	H	J	K	L	M	N	P	R	S	T	U	V	W	X	Y	4	7		
		Outer diameter Unit: mm (in)	Inner diameter Unit: mm (in)																										
A	54.979 - 54.978 (2.1645 - 2.1645)	0	0	0	0	0	0	0	0	0	0	01	01	01	01	1	1	1	12	12	12	2	2	2	23	23	23	3	3
B	54.978 - 54.977 (2.1645 - 2.1644)	0	0	0	0	0	0	0	0	0	01	01	01	01	1	1	1	12	12	12	2	2	2	23	23	23	3	3	
C	54.977 - 54.976 (2.1644 - 2.1644)	0	0	0	0	0	0	0	01	01	01	01	1	1	1	12	12	12	2	2	2	2	23	23	23	3	3		
D	54.976 - 54.975 (2.1644 - 2.1644)	0	0	0	0	0	01	01	01	01	1	1	1	1	12	12	12	2	2	2	2	23	23	23	3	3	34		
E	54.975 - 54.974 (2.1644 - 2.1643)	0	0	0	0	01	01	01	01	1	1	1	1	12	12	12	2	2	2	2	23	23	23	3	3	3	34	34	
F	54.974 - 54.973 (2.1643 - 2.1643)	0	0	0	01	01	01	01	1	1	1	1	12	12	12	2	2	2	2	23	23	23	3	3	3	34	34	34	
G	54.973 - 54.972 (2.1643 - 2.1642)	0	0	01	01	01	1	1	1	1	12	12	12	2	2	2	23	23	23	3	3	3	3	34	34	34	4	4	
H	54.972 - 54.971 (2.1642 - 2.1642)	0	01	01	01	1	1	1	1	12	12	12	2	2	2	23	23	23	3	3	3	3	34	34	34	4	4	4	
J	54.971 - 54.970 (2.1642 - 2.1642)	01	01	01	1	1	1	12	12	12	2	2	2	2	23	23	23	3	3	3	3	34	34	34	4	4	4	4	
K	54.970 - 54.969 (2.1642 - 2.1641)	01	01	1	1	1	12	12	12	2	2	2	23	23	23	3	3	3	34	34	34	4	4	4	4	4	4	45	
L	54.969 - 54.968 (2.1641 - 2.1641)	01	1	1	1	12	12	12	2	2	2	23	23	23	3	3	3	34	34	34	4	4	4	4	4	4	45	45	
M	54.968 - 54.967 (2.1641 - 2.1641)	1	1	1	12	12	12	2	2	2	23	23	23	3	3	3	34	34	34	4	4	4	4	4	4	45	45	45	
N	54.967 - 54.966 (2.1641 - 2.1640)	1	1	12	12	12	2	2	2	23	23	23	3	3	3	34	34	34	4	4	4	4	4	4	45	45	45	5	
P	54.966 - 54.965 (2.1640 - 2.1640)	1	12	12	12	2	2	2	23	23	23	3	3	3	34	34	34	4	4	4	4	4	4	45	45	45	5	5	
R	54.965 - 54.964 (2.1640 - 2.1639)	12	12	12	2	2	2	23	23	23	3	3	3	34	34	34	4	4	4	4	4	45	45	45	5	5	5	5	
S	54.964 - 54.963 (2.1639 - 2.1639)	12	12	2	2	2	23	23	23	3	3	3	34	34	34	4	4	4	4	4	45	45	45	5	5	5	5	56	
T	54.963 - 54.962 (2.1639 - 2.1639)	12	2	2	2	23	23	23	3	3	3	34	34	34	4	4	4	4	4	45	45	45	5	5	5	5	56	56	
U	54.962 - 54.961 (2.1639 - 2.1638)	2	2	2	23	23	23	3	3	3	34	34	34	4	4	4	4	4	45	45	45	5	5	5	5	56	56	56	
V	54.961 - 54.960 (2.1638 - 2.1638)	2	2	23	23	23	3	3	3	34	34	34	4	4	4	4	45	45	45	5	5	5	5	5	56	56	56	6	
W	54.960 - 54.959 (2.1638 - 2.1637)	2	23	23	23	3	3	3	34	34	34	4	4	4	4	45	45	45	5	5	5	5	5	56	56	56	6	6	
X	54.959 - 54.958 (2.1637 - 2.1637)	23	23	23	3	3	3	34	34	34	4	4	4	4	45	45	45	5	5	5	5	5	56	56	56	6	6	6	
Y	54.958 - 54.957 (2.1637 - 2.1637)	23	23	3	3	3	34	34	34	4	4	4	4	4	45	45	45	5	5	5	5	56	56	56	6	6	6	67	
4	54.957 - 54.956 (2.1637 - 2.1636)	23	3	3	3	34	34	34	4	4	4	4	45	45	45	5	5	5	5	56	56	56	6	6	6	6	67	67	
7	54.956 - 54.955 (2.1636 - 2.1636)	3	3	3	34	34	34	4	4	4	4	45	45	45	5	5	5	5	56	56	56	6	6	6	6	67	67	67	

KBIA0150E

Main Bearing Grade Table (All Journals) Refer to [EM-101, "Standard and Limit"](#).

Use Undersize Bearing Usage Guide

- Use undersize (U.S.) bearing when oil clearance with standard size main bearing is not within specification.
- When using undersize (U.S.) bearing, measure the bearing inner diameter with the bearing installed and grind journal until oil clearance falls within specification.

Bearing Undersize Table

Size U.S.	Thickness
0.25 (0.0098)	2.106 - 2.114 (0.0829 - 0.0832)

Unit: mm (in)

CAUTION:

Do not damage fillet R when grinding crankshaft journal in order to use an undersize bearing (all journals).

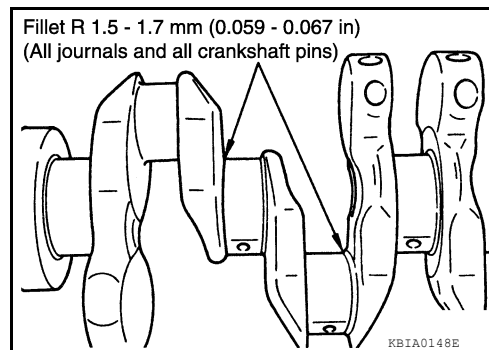

KBIA0148E

SERVICE DATA AND SPECIFICATIONS (SDS)

< SERVICE DATA AND SPECIFICATIONS (SDS)

[QR25DE]

SERVICE DATA AND SPECIFICATIONS (SDS)

SERVICE DATA AND SPECIFICATIONS (SDS)

Standard and Limit

INFOID:000000007420256

A

EM

GENERAL SPECIFICATIONS

Cylinder arrangement	In-line 4	
Displacement cm ³ (in ³)	2,488 (151.82)	
Bore and stroke mm. (in)	89.0 x 100 (3.50 x 3.94)	
Valve arrangement	DOHC	
Firing order	1-3-4-2	
Number of piston rings	Compression	2
	Oil	1
Compression ratio	9.5:1	
Compression pressure kPa (bar, kg/cm ² , psi) / 250 rpm	Standard	1,250 (12.50, 12.8, 181.3)
	Minimum	1,060 (10.60, 10.8, 153.7)
	Differential limit between cylinders	100 (1.00, 1.0, 14)

C

D

E

F

G

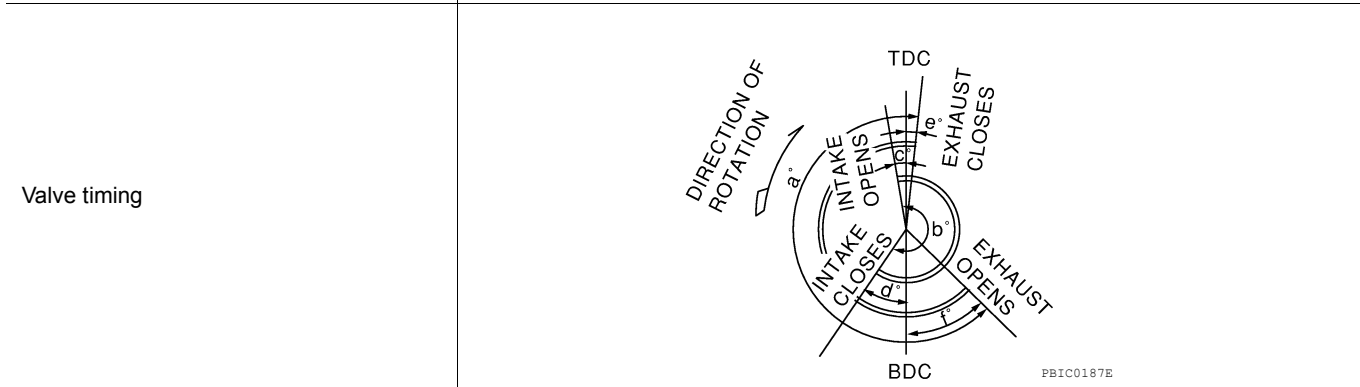

H

I

J

K

Unit: degree					
a	b	c	d	e	f
220	232	-12	64	10	30

L

DRIVE BELTS

Tension of drive belts	Auto adjustment by auto-tensioner
------------------------	-----------------------------------

M

INTAKE MANIFOLD AND EXHAUST MANIFOLD

Unit: mm. (in)

	Description	Limit
Surface distortion	Intake manifold adapter	0.1 (0.004)
	Intake manifold	0.1 (0.004)
	Exhaust manifold	0.3 (0.012)

N

O

P

SPARK PLUG

Unit: mm. (in)

Make	NGK	
Type*	Standard	DILKAR6A-11
Gap (nominal)	1.1 (0.043)	

*: Always check with the Parts Department for the latest parts information.

SERVICE DATA AND SPECIFICATIONS (SDS)

< SERVICE DATA AND SPECIFICATIONS (SDS)

[QR25DE]

CYLINDER HEAD

Unit: mm. (in)

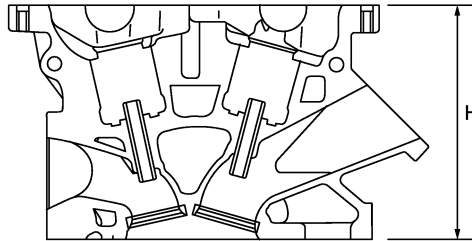

Nominal cylinder head height:
H = 129.4 mm (5.09 in)

PBIC0283E

Description	Limit
Head surface distortion	0.1 (0.004)
Description	Standard
Spark plug tube installation height	41.7 (1.642)

VALVE

Valve Dimensions

Unit: mm. (in)

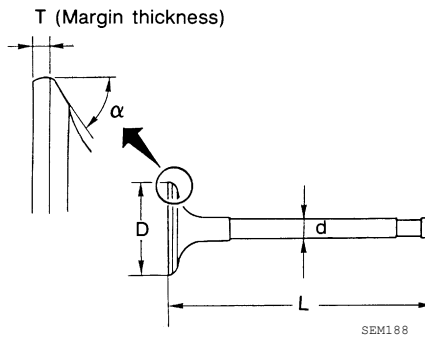

Valve head diameter (D)	Intake	35.5 - 35.8 (1.398 - 1.409)
	Exhaust	30.3 - 30.6 (1.193 - 1.205)
Valve length (L)	Intake	96.84 (3.8136)
	Exhaust	97.9 (3.8553)
Valve stem diameter (d)	Intake	5.965 - 5.980 (0.2348 - 0.2354)
	Exhaust	5.955 - 5.970 (0.2344 - 0.2350)
Valve seat angle (α)	Intake	45°15' - 45°45'
	Exhaust	
Valve margin (T)	Intake	1.08 (0.0425)
	Exhaust	1.38 (0.0543)

Valve Clearance

Unit: mm. (in)

	Cold	Hot*
Intake	0.24 - 0.32 (0.009 - 0.013)	0.304 - 0.416 (0.012 - 0.016)
Exhaust	0.26 - 0.34 (0.010 - 0.013)	0.308 - 0.432 (0.012 - 0.017)

* Approximately 80°C (176°F)

Available Valve Lifter

SERVICE DATA AND SPECIFICATIONS (SDS)

< SERVICE DATA AND SPECIFICATIONS (SDS)

[QR25DE]

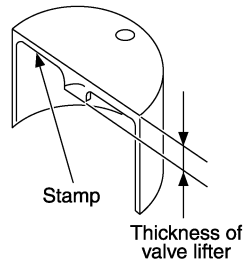

KBIA0119E

Thickness mm. (in)	Identification mark (Stamp)*
7.88 (0.310)	788U
7.90 (0.311)	790U
7.92 (0.312)	792U
7.94 (0.313)	794U
7.96 (0.313)	796U
7.98 (0.314)	798U
8.00 (0.315)	800U
8.02 (0.316)	802U
8.04 (0.317)	804U
8.06 (0.317)	806U
8.08 (0.318)	808U
8.10 (0.319)	810U
8.12 (0.320)	812U
8.14 (0.320)	814U
8.16 (0.321)	816U
8.18 (0.322)	818U
8.20 (0.323)	820U
8.22 (0.324)	822U
8.24 (0.324)	824U
8.26 (0.325)	826U
8.28 (0.326)	828U
8.30 (0.327)	830U
8.32 (0.328)	832U
8.34 (0.328)	834U
8.36 (0.329)	836U
8.38 (0.330)	838U

*: Always check with the Parts Department for the latest parts information.

Valve Spring

STANDARD	INTAKE	EXHAUST
Free height	43.72 - 43.92 mm (1.7213 - 1.7291 in)	45.29 - 45.49 mm (1.7831 - 1.7909 in)
Installation height	35.30 mm (1.390 in)	35.30 mm (1.390 in)
Installation load	151 - 175 N (1.51 - 1.75 bar, 15.4 - 17.8 kg-f, 34 - 39 lb-f)	151 - 175 N (1.51 - 1.75 bar, 15.4 - 17.8 kg-f, 34 - 39 lb-f)
Height during valve open	25.30 mm (0.9961 in)	26.76 mm (1.0535 in)

SERVICE DATA AND SPECIFICATIONS (SDS)

< SERVICE DATA AND SPECIFICATIONS (SDS)

[QR25DE]

STANDARD	INTAKE	EXHAUST
Load with valve open	351 - 394 N (3.51 - 3.94 bar, 35.8 - 40.2 kg-f, 79 - 89 lb-f)	318 - 362 N (3.18 - 3.62 bar, 32.4 - 37.8 kg-f, 72 - 81 lb-f)
Squareness	1.9 mm (0.0748 in)	1.9 mm (0.0748 in)

Valve Lifter

Unit: mm. (in)

Description	Standard
Valve lifter outer diameter	33.977 - 33.987 (1.3377 - 1.3381)
Valve lifter bore inner diameter	34.000 - 34.021 (1.3386 - 1.3394)
Clearance between lifter and lifter guide	0.013 - 0.044 (0.0005 - 0.0017)

Valve Oil Seal

Unit: mm. (in)

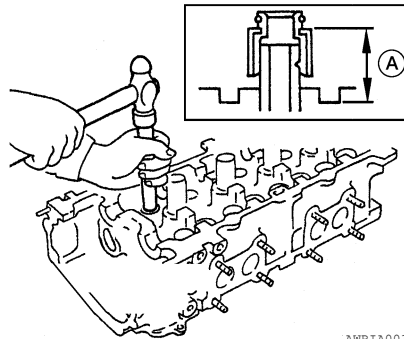

AWBIA00192Z

Description	Standard
Valve oil seal installation height (A)	12.1 (0.476)

Valve Guide

Unit: mm. (in)

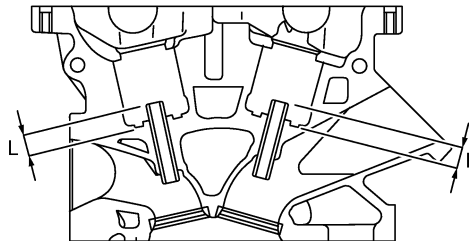

PBIC0184E

Description		Standard	Service
Valve guide	Outer diameter	10.023 - 10.034 (0.3946 - 0.3950)	10.223 - 10.234 (0.4025 - 0.4029)
	Inner diameter (Finished size)	6.000 - 6.018 (0.2362 - 0.2369)	
Cylinder head valve guide hole diameter		9.975 - 9.996 (0.3927 - 0.3935)	10.175 - 10.196 (0.4006 - 0.4014)
Interference fit of valve guide		0.027 - 0.059 (0.0011 - 0.0023)	
Standard			
Valve guide clearance (Standard)	Intake	0.020 - 0.053 (0.0008 - 0.0021)	
	Exhaust	0.030 - 0.063 (0.0012 - 0.0025)	
Valve guide clearance (Limit)	Intake	0.08 (0.003)	
	Exhaust	0.09 (0.004)	

SERVICE DATA AND SPECIFICATIONS (SDS)

< SERVICE DATA AND SPECIFICATIONS (SDS)

[QR25DE]

Projection length (L)	Intake	10.1 - 10.3 (0.398 - 0.406)
	Exhaust	10.0 - 10.4 (0.394 - 0.409)

Valve Seat

Unit: mm. (in)

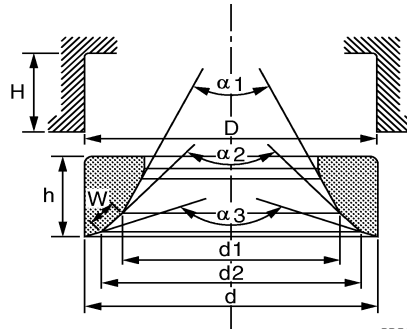

PBIC2745E

Description		Standard	Service
Cylinder head seat recess diameter (D)	Intake	36.500 - 36.516 (1.4370 - 1.4376)	37.000 - 37.016 (1.4567 - 1.4573)
	Exhaust	31.500 - 31.516 (1.2402 - 1.2408)	32.000 - 32.016 (1.2598 - 1.2605)
Valve seat interference fit	Intake	0.081 - 0.113 (0.0032 - 0.0044)	
	Exhaust	0.084 - 0.116 (0.0033 - 0.0046)	
Valve seat outer diameter (d)	Intake	36.597 - 36.613 (1.4408 - 1.4415)	37.097 - 37.113 (1.4605 - 1.4611)
	Exhaust	31.600 - 31.616 (1.2441 - 1.2447)	32.100 - 32.116 (1.2638 - 1.2644)
Diameter (d1)	Intake	33.5 (1.319)	
	Exhaust	28.0 (1.102)	
Diameter (d2)	Intake	34.8 - 35.3 (1.370 - 1.390)	
	Exhaust	29.6 - 30.1 (1.165 - 1.185)	
Angle (α_1)	Intake	60°	
	Exhaust	60°	
Angle (α_2)	Intake	88° 46' - 90° 14'	
	Exhaust	88° 46' - 90° 14'	
Angle (α_3)	Intake	120°	
	Exhaust	120°	
Contacting width (W)*1	Intake	0.99 - 1.35 (0.0390 - 0.0531)	
	Exhaust	1.19 - 1.55 (0.0469 - 0.0610)	

*1 Machining data

CAMSHAFT AND CAMSHAFT BEARING

SERVICE DATA AND SPECIFICATIONS (SDS)

< SERVICE DATA AND SPECIFICATIONS (SDS)

[QR25DE]

Unit: mm. (in)

	Standard
Camshaft runout [TIR*]	Less than 0.04 (0.0016)

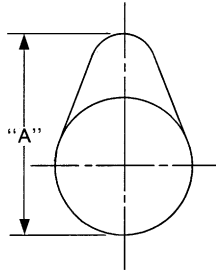

SEM671

Cam height (A)	Intake	44.815 - 45.005 (1.7644 - 1.7718)
	Exhaust	43.975 - 44.165 (1.7313 - 1.7388)
Outer diameter of camshaft journal	No. 1	27.935 - 27.955 (1.0998 - 1.1006)
	No. 2, 3, 4, 5	23.435 - 23.455 (0.9226 - 0.9234)
Inner diameter of camshaft bracket	No.1	28.000 - 28.021 (1.1024 - 1.1032)
	No.2, 3, 4, 5	23.500 - 23.521 (0.9252 - 0.9260)
Camshaft journal clearance		0.045 - 0.086 (0.0018 - 0.0034)
Camshaft end play		0.115 - 0.188 (0.0045 - 0.0074)
Camshaft sprocket runout [TIR*]		Less than 0.15 (0.0059)

*: Total indicator reading

CYLINDER BLOCK

Unit: mm. (in)

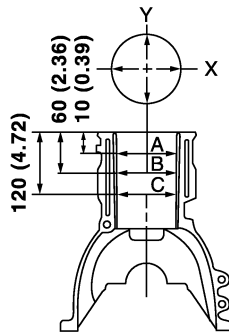

PBIC0281E

Surface distortion	Limit	0.1 (0.004)
Cylinder bore	Inner diameter	Standard
		Grade No. 2
	Grade No. 3	89.020 - 89.030 (3.5047 - 3.5051)
	Wear limit	0.2 (0.008)
Out-of-round (X - Y)		Less than 0.015 (0.0006)
Taper (C - A)		Less than 0.01 (0.0004)

SERVICE DATA AND SPECIFICATIONS (SDS)

< SERVICE DATA AND SPECIFICATIONS (SDS)

[QR25DE]

Main journal inner diameter grade (Without bearing)*	Grade No. A	58.944 - 58.945 (2.3206 - 2.3207)	A
	Grade No. B	58.945 - 58.946 (2.3207 - 2.3207)	
	Grade No. C	58.946 - 58.947 (2.3207 - 2.3207)	
	Grade No. D	58.947 - 58.948 (2.3207 - 2.3208)	
	Grade No. E	58.948 - 58.949 (2.3208 - 2.3208)	
	Grade No. F	58.949 - 58.950 (2.3208 - 2.3209)	
	Grade No. G	58.950 - 58.951 (2.3209 - 2.3209)	
	Grade No. H	58.951 - 58.952 (2.3209 - 2.3209)	
	Grade No. J	58.952 - 58.953 (2.3209 - 2.3210)	C
	Grade No. K	58.953 - 58.954 (2.3210 - 2.3210)	
	Grade No. L	58.954 - 58.955 (2.3210 - 2.3211)	
	Grade No. M	58.955 - 58.956 (2.3211 - 2.3211)	
	Grade No. N	58.956 - 58.957 (2.3211 - 2.3211)	D
	Grade No. P	58.957 - 58.958 (2.3211 - 2.3212)	
	Grade No. R	58.958 - 58.959 (2.3212 - 2.3212)	
	Grade No. S	58.959 - 58.960 (2.3212 - 2.3213)	
	Grade No. T	58.960 - 58.961 (2.3213 - 2.3213)	E
	Grade No. U	58.961 - 58.962 (2.3213 - 2.3213)	
Grade No. V	58.962 - 58.963 (2.3213 - 2.3214)		
Grade No. W	58.963 - 58.964 (2.3214 - 2.3214)		
Grade No. X	58.964 - 58.965 (2.3214 - 2.3215)	F	
Grade No. Y	58.965 - 58.966 (2.3215 - 2.3215)		
Grade No. 4	58.966 - 58.967 (2.3215 - 2.3215)		
Grade No. 7	58.967 - 58.968 (2.3215 - 2.3216)	G	
Difference in inner diameter between cylinders	Standard	Less than 0.03 (0.0012)	H

*: Always check with the Parts Department for the latest parts information.

PISTON, PISTON RING, AND PISTON PIN

Available Piston

Unit: mm. (in)

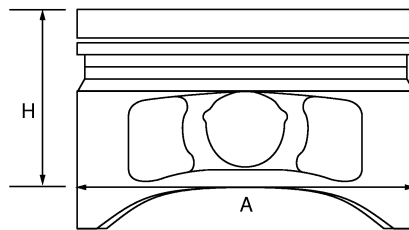

PBIC0188E

Piston skirt diameter (A)	Standard	Grade*	Dimension
		Grade No. 1	88.990 - 88.995 (3.5035 - 3.5037)
		Grade No. 2	88.995 - 89.000 (3.5037 - 3.5039)
		Grade No. 3	89.000 - 89.005 (3.5039 - 3.5041)
		Grade No. 4	89.005 - 89.010 (3.5041 - 3.5043)
(H) dimension			37.5 (1.476)
Piston pin bore diameter		Grade No. 0	19.993 - 19.999 (0.7871 - 0.7874)
		Grade No. 1	19.999 - 20.005 (0.7874 - 0.7876)
Piston clearance to cylinder block		Standard	0.010 - 0.030 (0.0004 - 0.0012)
		Limit	0.08 (0.0031)

*: Always check with the Parts Department for the latest parts information.

Piston Ring

SERVICE DATA AND SPECIFICATIONS (SDS)

< SERVICE DATA AND SPECIFICATIONS (SDS)

[QR25DE]

Unit: mm. (in)

		Standard	Limit
Side clearance	Top	0.040 - 0.080 (0.0016 - 0.0031)	0.11 (0.0043)
	2nd	0.030 - 0.070 (0.0012 - 0.0028)	0.10 (0.0039)
	Oil ring	0.045 - 0.125 (0.0018 - 0.0049)	—
End gap	Top	0.21 - 0.31 (0.0083 - 0.0122)	0.54 (0.0213)
	2nd	0.37 - 0.52 (0.0146 - 0.0205)	0.67 (0.0264)
	Oil (rail ring)	0.20 - 0.45 (0.0079 - 0.0177)	0.95 (0.0374)

Piston Pin

Unit: mm. (in)

Piston pin outer diameter	Grade No.0	19.989 - 19.995 (0.7870 - 0.7872)
	Grade No.1	19.995 - 20.001 (0.7872 - 0.7874)
Piston to piston pin clearance (Standard)		0.002 - 0.006 (0.0001 - 0.0002)
Piston pin to connecting rod bushing clearance	Standard	0.005 - 0.017 (0.0002 - 0.0007)

CONNECTING ROD

Unit: mm. (in)

Center distance		143.00 - 143.10 (5.63 - 5.63)
Bend [per 100 (3.94)]	Limit	0.15 (0.0059)
Torsion [per 100 (3.94)]	Limit	0.30 (0.0118)
Connecting rod small end inner diameter		22.000 - 22.012 (0.7874 - 0.7879)
Connecting rod small end inner bushing diameter ¹	Grade ²	Dimension
	Grade No. 0	20.000 - 20.006 (0.7874 - 0.7876)
	Grade No. 1	20.006 - 20.012 (0.7876 - 0.7879)
Connecting rod big end inner diameter		48.000 - 48.013 (1.8898 - 1.8903)
Side clearance	Standard	0.20 - 0.35 (0.0079 - 0.0138)
	Limit	0.50 (0.0197)
Connecting rod bearing housing	Grade ²	Dimension
	Grade No. 0	48.000 - 48.001 (1.8898 - 1.8898)
	Grade No. 1	48.001 - 48.002 (1.8898 - 1.8898)
	Grade No. 2	48.002 - 48.003 (1.8898 - 1.8899)
	Grade No. 3	48.003 - 48.004 (1.8899 - 1.8899)
	Grade No. 4	48.004 - 48.005 (1.8899 - 1.8899)
	Grade No. 5	48.005 - 48.006 (1.8899 - 1.8900)
	Grade No. 6	48.006 - 48.007 (1.8900 - 1.8900)
	Grade No. 7	48.007 - 48.008 (1.8900 - 1.8901)
	Grade No. 8	48.008 - 48.009 (1.8901 - 1.8901)
	Grade No. 9	48.009 - 48.010 (1.8901 - 1.8902)
Grade No. A	48.010 - 48.011 (1.8902 - 1.8902)	
Grade No. B	48.011 - 48.012 (1.8902 - 1.8902)	
Grade No. C	48.012 - 48.013 (1.8902 - 1.8903)	

¹: After installing in connecting rod.

²: Always check with the Parts Department for the latest parts information.

CRANKSHAFT

SERVICE DATA AND SPECIFICATIONS (SDS)

< SERVICE DATA AND SPECIFICATIONS (SDS)

[QR25DE]

Unit: mm. (in)

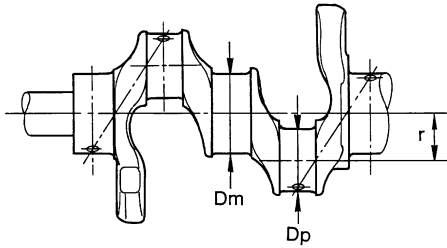

SEM645

Out-of-round (X - Y)
Taper (A - B)

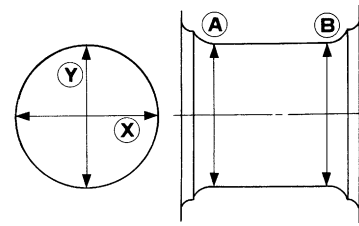

SEM715

Pin journal dia. (DP) grade ¹	Grade No. A	44.974 - 44.973 (1.7706 - 1.7706)
	Grade No. B	44.973 - 44.972 (1.7706 - 1.7705)
	Grade No. C	44.972 - 44.971 (1.7705 - 1.7705)
	Grade No. D	44.971 - 44.970 (1.7705 - 1.7705)
	Grade No. E	44.970 - 44.969 (1.7705 - 1.7704)
	Grade No. F	44.969 - 44.968 (1.7704 - 1.7704)
	Grade No. G	44.968 - 44.967 (1.7704 - 1.7704)
	Grade No. H	44.967 - 44.966 (1.7704 - 1.7703)
	Grade No. J	44.966 - 44.965 (1.7703 - 1.7703)
	Grade No. K	44.965 - 44.964 (1.7703 - 1.7702)
	Grade No. L	44.964 - 44.963 (1.7702 - 1.7702)
	Grade No. M	44.963 - 44.962 (1.7702 - 1.7702)
	Grade No. N	44.962 - 44.961 (1.7702 - 1.7701)
	Grade No. P	44.961 - 44.960 (1.7701 - 1.7701)
	Grade No. R	44.960 - 44.959 (1.7701 - 1.7700)
	Grade No. S	44.959 - 44.958 (1.7700 - 1.7700)
	Grade No. T	44.958 - 44.957 (1.7700 - 1.7700)
Grade No. U	44.957 - 44.956 (1.7700 - 1.7699)	
Main journal dia. (Dm) grade ¹	Grade No. A	54.979 - 54.978 (2.1645 - 2.1645)
	Grade No. B	54.978 - 54.977 (2.1645 - 2.1644)
	Grade No. C	54.977 - 54.976 (2.1644 - 2.1644)
	Grade No. D	54.976 - 54.975 (2.1644 - 2.1644)
	Grade No. E	54.975 - 54.974 (2.1644 - 2.1643)
	Grade No. F	54.974 - 54.973 (2.1643 - 2.1643)
	Grade No. G	54.973 - 54.972 (2.1643 - 2.1642)
	Grade No. H	54.972 - 54.971 (2.1642 - 2.1642)
	Grade No. J	54.971 - 54.970 (2.1642 - 2.1642)
	Grade No. K	54.970 - 54.969 (2.1642 - 2.1641)
	Grade No. L	54.969 - 54.968 (2.1641 - 2.1641)
	Grade No. M	54.968 - 54.967 (2.1641 - 2.1641)
	Grade No. N	54.967 - 54.966 (2.1641 - 2.1640)
	Grade No. P	54.966 - 54.965 (2.1640 - 2.1640)
	Grade No. R	54.965 - 54.964 (2.1640 - 2.1639)
	Grade No. S	54.964 - 54.963 (2.1639 - 2.1639)
	Grade No. T	54.963 - 54.962 (2.1639 - 2.1639)
	Grade No. U	54.962 - 54.961 (2.1639 - 2.1638)
	Grade No. V	54.961 - 54.960 (2.1638 - 2.1638)
	Grade No. W	54.960 - 54.959 (2.1638 - 2.1637)
Grade No. X	54.959 - 54.958 (2.1637 - 2.1637)	
Grade No. Y	54.958 - 54.957 (2.1637 - 2.1637)	
Grade No. 4	54.957 - 54.956 (2.1637 - 2.1636)	
Grade No. 7	54.956 - 54.955 (2.1636 - 2.1636)	
Center distance (r)		49.60 - 50.04 (1.9528 - 1.9701)
Out-of-round (X - Y)	Standard	Less than 0.005 (0.0002)
Taper (A - B)	Standard	Less than 0.005 (0.0002)
Runout [TIR ²]	Limit	Less than 0.05 (0.002)
Free end play	Standard	0.10 - 0.26 (0.0039 - 0.0102)
	Limit	0.30 (0.0118)

SERVICE DATA AND SPECIFICATIONS (SDS)

< SERVICE DATA AND SPECIFICATIONS (SDS)

[QR25DE]

¹: Always check the Parts Department for the latest parts information.

²: Total indicator reading

MAIN BEARING

Unit: mm. (in)

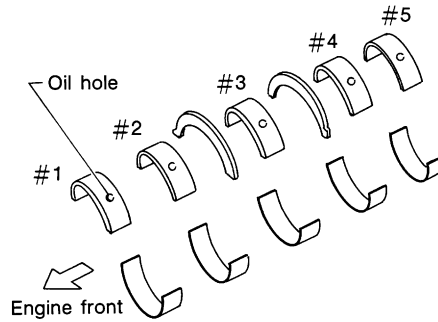

SEM685D

Grade number*		Thickness	Identification color	Remarks
0		1.973 - 1.976 (0.0777 - 0.0778)	Black	Grade and color are the same for upper and lower bearings.
1		1.976 - 1.979 (0.0778 - 0.0779)	Brown	
2		1.979 - 1.982 (0.0779 - 0.0780)	Green	
3		1.982 - 1.985 (0.0780 - 0.0781)	Yellow	
4		1.985 - 1.988 (0.0781 - 0.0783)	Blue	
5		1.988 - 1.991 (0.0783 - 0.0784)	Pink	
6		1.991 - 1.994 (0.0784 - 0.0785)	Purple	
7		1.994 - 1.997 (0.0785 - 0.0786)	White	
01	UPR	1.973 - 1.976 (0.0777 - 0.0778)	Black	Grade and color are different for upper and lower bearings.
	LWR	1.976 - 1.979 (0.0778 - 0.0779)	Brown	
12	UPR	1.976 - 1.979 (0.0778 - 0.0779)	Brown	
	LWR	1.979 - 1.982 (0.0779 - 0.0780)	Green	
23	UPR	1.979 - 1.982 (0.0779 - 0.0780)	Green	
	LWR	1.982 - 1.985 (0.0780 - 0.0781)	Yellow	
34	UPR	1.982 - 1.985 (0.0780 - 0.0781)	Yellow	
	LWR	1.985 - 1.988 (0.0781 - 0.0783)	Blue	
45	UPR	1.985 - 1.988 (0.0781 - 0.0783)	Blue	
	LWR	1.988 - 1.991 (0.0783 - 0.0784)	Pink	
56	UPR	1.988 - 1.991 (0.0783 - 0.0784)	Pink	
	LWR	1.991 - 1.994 (0.0784 - 0.0785)	Purple	
67	UPR	1.991 - 1.994 (0.0784 - 0.0785)	Purple	
	LWR	1.994 - 1.997 (0.0785 - 0.0786)	White	

*: Always check with the Parts Department for the latest parts information.

Undersize

Unit: mm. (in)

Size U.S.	Thickness	Main journal diameter
0.25 (0.0098)	2.106 - 2.114 (0.0829 - 0.0832)	Grind so that bearing clearance is the specified value.

Bearing Clearance

SERVICE DATA AND SPECIFICATIONS (SDS)

< SERVICE DATA AND SPECIFICATIONS (SDS)

[QR25DE]

Unit: mm. (in)

Main bearing oil clearance	Standard	No.1, 3, and 5	0.012 - 0.022 (0.0005 - 0.0009)
		No.2 and 4	0.018 - 0.028 (0.0007 - 0.0011)
	Limit		0.1 (0.004)

A

EM

CONNECTING ROD BEARING

Grade number*	Thickness mm. (in)	Identification color (mark)
0 (upper)	1.496 - 1.493 (0.0589 - 0.0588)	Black
0 (lower)	1.496 - 1.493 (0.0589 - 0.0588)	Black
01 (upper)	1.496 - 1.493 (0.0589 - 0.0588)	Black
01 (lower)	1.499 - 1.496 (0.0590 - 0.0589)	Brown
1 (upper)	1.499 - 1.496 (0.0590 - 0.0589)	Brown
1 (lower)	1.499 - 1.496 (0.0590 - 0.0589)	Brown
12 (upper)	1.499 - 1.496 (0.0590 - 0.0589)	Brown
12 (lower)	1.502 - 1.499 (0.0591 - 0.0590)	Green
2 (upper)	1.502 - 1.499 (0.0591 - 0.0590)	Green
2 (lower)	1.502 - 1.499 (0.0591 - 0.0590)	Green
23 (upper)	1.502 - 1.499 (0.0591 - 0.0590)	Green
23 (lower)	1.507 - 1.502 (0.0593 - 0.0591)	Yellow
3 (upper)	1.507 - 1.502 (0.0593 - 0.0591)	Yellow
3 (lower)	1.507 - 1.502 (0.0593 - 0.0591)	Yellow
34 (upper)	1.507 - 1.502 (0.0593 - 0.0591)	Yellow
34 (lower)	1.508 - 1.505 (0.0594 - 0.0593)	Blue
4 (upper)	1.508 - 1.505 (0.0594 - 0.0593)	Blue
4 (lower)	1.508 - 1.505 (0.0594 - 0.0593)	Blue

C

D

E

F

G

H

I

J

*: Always check with the Parts Department for the latest parts information.

Undersize

Unit: mm. (in)

Size U.S.	Thickness	Crank pin journal diameter
0.25 (0.0098)	1.622 - 1.630 (0.0639 - 0.0642)	Grind so that bearing clearance is the specified value.

K

L

Bearing Clearance

Unit: mm. (in)

Connecting rod bearing clearance	Standard	0.035 - 0.045 (0.0014 - 0.0018)
	Limit	0.10 (0.0039)

M

N

FLYWHEEL

Unit: mm. (in)

Deflection of flywheel contact surface to the clutch	Limit	0.45 (0.0177) or less under no load
Axial displacement at 250 (9.84) dia	Limit	1.3 (0.051) or less under 100 N (10.2 kg-f, 22.5 lb)
Movement amount (A) and (B) on circumference of the flywheel (transmission side)	Standard	35 (1.38) or less

O

P

PRECAUTION

PRECAUTIONS

Precaution for Supplemental Restraint System (SRS) "AIR BAG" and "SEAT BELT PRE-TENSIONER"

INFOID:000000007420257

The Supplemental Restraint System such as "AIR BAG" and "SEAT BELT PRE-TENSIONER", used along with a front seat belt, helps to reduce the risk or severity of injury to the driver and front passenger for certain types of collision. This system includes seat belt switch inputs and dual stage front air bag modules. The SRS system uses the seat belt switches to determine the front air bag deployment, and may only deploy one front air bag, depending on the severity of a collision and whether the front occupants are belted or unbelted. Information necessary to service the system safely is included in the SR and SB section of this Service Manual.

WARNING:

- To avoid rendering the SRS inoperative, which could increase the risk of personal injury or death in the event of a collision which would result in air bag inflation, all maintenance must be performed by an authorized NISSAN/INFINITI dealer.
- Improper maintenance, including incorrect removal and installation of the SRS, can lead to personal injury caused by unintentional activation of the system. For removal of Spiral Cable and Air Bag Module, see the SR section.
- Do not use electrical test equipment on any circuit related to the SRS unless instructed to in this Service Manual. SRS wiring harnesses can be identified by yellow and/or orange harnesses or harness connectors.

PRECAUTIONS WHEN USING POWER TOOLS (AIR OR ELECTRIC) AND HAMMERS

WARNING:

- When working near the Airbag Diagnosis Sensor Unit or other Airbag System sensors with the Ignition ON or engine running, DO NOT use air or electric power tools or strike near the sensor(s) with a hammer. Heavy vibration could activate the sensor(s) and deploy the air bag(s), possibly causing serious injury.
- When using air or electric power tools or hammers, always switch the Ignition OFF, disconnect the battery, and wait at least 3 minutes before performing any service.

Precaution Necessary for Steering Wheel Rotation After Battery Disconnect

INFOID:000000007420258

NOTE:

- Before removing and installing any control units, first turn the push-button ignition switch to the LOCK position, then disconnect both battery cables.
- After finishing work, confirm that all control unit connectors are connected properly, then re-connect both battery cables.
- Always use CONSULT to perform self-diagnosis as a part of each function inspection after finishing work. If a DTC is detected, perform trouble diagnosis according to self-diagnosis results.

This vehicle is equipped with a push-button ignition switch and a steering lock unit.

If the battery is disconnected or discharged, the steering wheel will lock and cannot be turned.

If turning the steering wheel is required with the battery disconnected or discharged, follow the procedure below before starting the repair operation.

OPERATION PROCEDURE

1. Connect both battery cables.

NOTE:

Supply power using jumper cables if battery is discharged.

2. Carry the Intelligent Key or insert it to the key slot and turn the push-button ignition switch to ACC position. (At this time, the steering lock will be released.)
3. Disconnect both battery cables. The steering lock will remain released with both battery cables disconnected and the steering wheel can be turned.
4. Perform the necessary repair operation.

PRECAUTIONS

< PRECAUTION >

[VQ35DE]

5. When the repair work is completed, re-connect both battery cables. With the brake pedal released, turn the push-button ignition switch from ACC position to ON position, then to LOCK position. (The steering wheel will lock when the push-button ignition switch is turned to LOCK position.)
6. Perform self-diagnosis check of all control units using CONSULT.

Precaution for Drain Coolant

INFOID:000000007420259

- Drain coolant when engine is cooled.

Precaution for Disconnecting Fuel Piping

INFOID:000000007420260

- Before starting work, make sure no fire or spark producing items are in the work area.
- Release fuel pressure before disassembly.
- After disconnecting pipes, plug openings to stop fuel leakage.

Precaution for Removal and Disassembly

INFOID:000000007420261

- When instructed to use special service tools, use the specified tools. Always be careful to work safely, avoid forceful or uninstructed operations.
- Exercise maximum care to avoid damage to mating or sliding surfaces.
- Cover openings of engine system with tape or the equivalent, if necessary, to seal out foreign materials.
- Mark and arrange disassembly parts in an organized way for easy troubleshooting and assembly.
- When loosening nuts and bolts, as a basic rule, start with the one furthest outside, then the one diagonally opposite, and so on. If the order of loosening is specified, do exactly as specified. Power tools may be used where noted in the step.

Precaution for Inspection, Repair and Replacement

INFOID:000000007420262

- Before repairing or replacing, thoroughly inspect parts. Inspect new replacement parts in the same way, and replace if necessary.

Precaution for Assembly and Installation

INFOID:000000007420263

- Use torque wrench to tighten bolts or nuts to specification.
- When tightening nuts and bolts, as a basic rule, equally tighten in several different steps starting with the ones in center, then ones on inside and outside diagonally in this order. If the order of tightening is specified, do exactly as specified.
- Replace with new gasket, packing, oil seal or O-ring.
- Thoroughly wash, clean, and air-blow each part. Carefully check oil or coolant passages for any restriction and blockage.
- Avoid damaging sliding or mating surfaces. Completely remove foreign materials such as cloth lint or dust. Before assembly, oil sliding surfaces well.
- Release air within route after draining coolant.
- Before starting engine, apply fuel pressure to fuel lines with turning ignition switch ON (with engine stopped). Then make sure that there are no leaks at fuel line connections.
- After repairing, start engine and increase engine speed to check coolant, fuel, oil, and exhaust systems for leakage.

Parts Requiring Angular Tightening

INFOID:000000007420264

- Use an angle wrench for the final tightening of the following engine parts:
 - Cylinder head bolts
 - Main bearing cap bolts
 - Connecting rod cap nuts
 - Crankshaft pulley bolt (No angle wrench is required as the bolt flange is provided with notches for angular tightening)
- Do not use a torque value for final tightening.
- The torque value for these parts are for a preliminary step.
- Ensure thread and seat surfaces are clean and coated with engine oil.

Precaution for Liquid Gasket

INFOID:000000007420265

REMOVAL OF LIQUID GASKET SEALANT

PRECAUTIONS

[VQ35DE]

< PRECAUTION >

- After removing the bolts and nuts, separate the mating surface and remove the old liquid gasket sealant using Tool.

Tool number : KV10111100 (J-37228)

CAUTION:

Do not damage mating surfaces.

- Tap the seal cutter to insert it (1).
- In areas where the Tool is difficult to use, lightly tap to slide it (2).

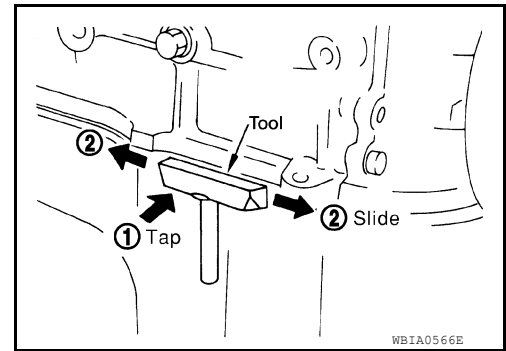

LIQUID GASKET APPLICATION PROCEDURE

1. Using a scraper, remove the old Silicone RTV Sealant adhering to the gasket application surface and the mating surface.
 - Remove the sealant completely from the groove of the gasket application surface, bolts, and bolt holes.
2. Thoroughly clean the gasket application surface and the mating surface and remove adhering moisture, grease and foreign materials.

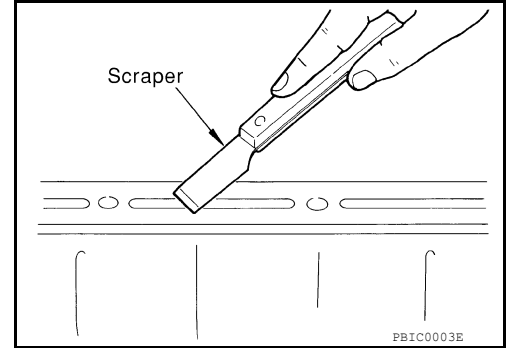

3. Attach the sealant tube to the Tool.
Use Genuine Silicone RTV Sealant or equivalent. Refer to [GI-15, "Recommended Chemical Products and Sealants"](#).

Tool number : WS39930000 (—)

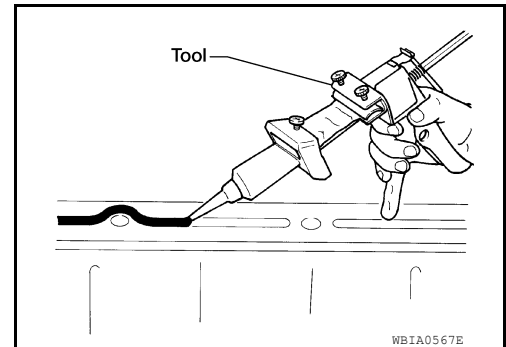

4. Apply the sealant using Tool without breaks to the specified location.
 - If there is a groove for the sealant application, apply the sealant to the groove.
 - As for the bolt holes, normally apply the sealant inside the holes. If specified, it should be applied outside the holes. Make sure to read the text of this manual.
 - Within five minutes of the sealant application, install the mating component.
 - If the sealant protrudes, wipe it off immediately.
 - Do not retighten after the installation.
 - After 30 minutes or more have passed from the installation, fill the engine with the specified oil and coolant. Refer to [MA-12, "Fluids and Lubricants"](#).

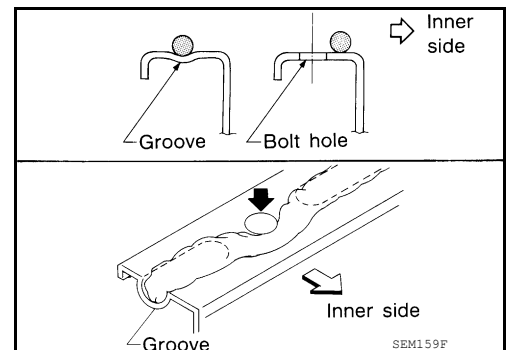

CAUTION:

Carefully follow all of the warnings, cautions, notes, and procedures contained in this manual.

PREPARATION

< PREPARATION >

[VQ35DE]

PREPARATION

PREPARATION

Special Service Tool

INFOID:000000007420266

A

EM

The actual shapes of Kent-Moore tools may differ from those of special service tools illustrated here.

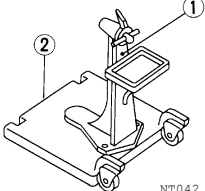
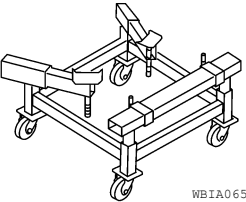
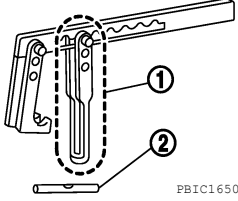
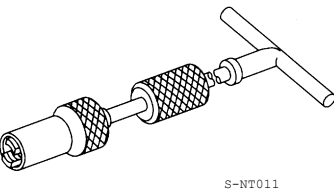
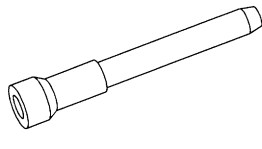
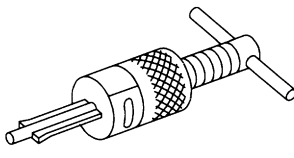
Tool number (Kent-Moore No.) Tool name	Description
ST0501S000 (—) Engine stand assembly 1. ST05011000 (—) Engine stand 2. ST05012000 (—) Base	 Disassembling and assembling NT042
KV101J0010 (J-47242) Engine support table	 Engine and transmission assembly removal WBIA0658E
KV10116200 (J-26336-A) Valve spring compressor 1. KV10115900 (J-26336-20) Attachment 2. KV10109220 (—) Adapter	 Disassembling valve mechanism Part (1) is a component of KV10116200 (J-26336-A), but part (2) is not. PBIC1650E
KV10107902 (J-38959) Valve oil seal puller	 Removing valve oil seal S-NT011
— (J-39386) Valve oil seal drift	 Installing valve oil seal NT024
ST16610001 (J-23907) Pilot bushing puller	 Removing crankshaft pilot bushing NT045

C

D

E

F

G

H

I

J

K

L

M

N

O

P

PREPARATION

< PREPARATION >

[VQ35DE]

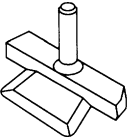
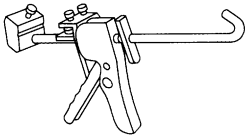
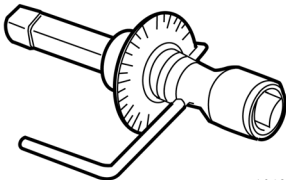
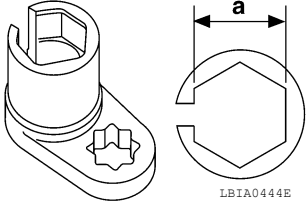
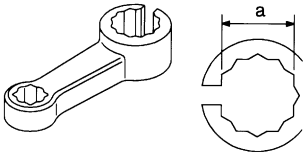
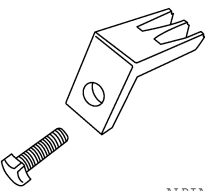
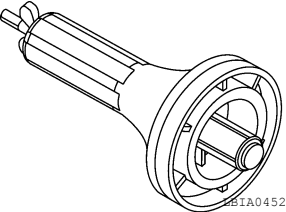
Tool number (Kent-Moore No.) Tool name	Description
KV10111100 (J-37228) Seal cutter	Removing steel oil pan and rear timing chain case  <p style="text-align: center;">NT046</p>
WS39930000 (—) Tube presser	Pressing the tube of liquid gasket  <p style="text-align: center;">NT052</p>
KV10112100 (BT-8653-A) Angle wrench	Tightening bolts for bearing cap, cylinder head, etc.  <p style="text-align: center;">AWBIA1043ZZ</p>
KV991J0050 (J-44626) Air fuel sensor Socket	Loosening or tightening air fuel ratio A/F sensor a: 22 mm (0.87 in)  <p style="text-align: center;">LBIA0444E</p>
KV10114400 (J-38365) Heated oxygen sensor wrench	Loosening or tightening rear heated oxygen sensor a: 22 mm (0.87 in)  <p style="text-align: center;">NT636</p>
— (J-50288) Ring gear stopper	Removing and installing crankshaft pulley  <p style="text-align: center;">ALBIA0675ZZ</p>
— (J-47128) Seal installer	Installing rear main seal  <p style="text-align: center;">LBIA0452E</p>



PREPARATION

< PREPARATION >

[VQ35DE]

Commercial Service Tool

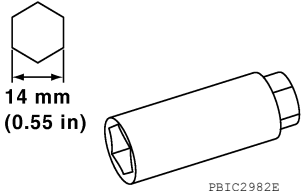
INFOID:000000007420267

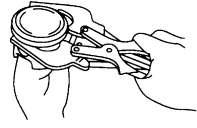
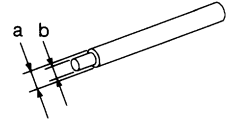
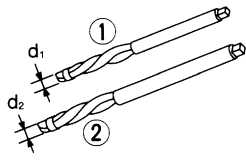
(Kent-Moore No.) Tool name	Description
Power tool  PIIB1407E	Loosening nuts, screws and bolts
Spark plug wrench  PBIC2982E	Removing and installing spark plug
Valve seat cutter set  NT048	Finishing valve seat dimensions
Piston ring expander  NT030	Removing and installing piston ring
Valve guide drift  NT015	Removing and installing valve guide Intake & Exhaust: a: 9.5 mm (0.374 in) dia. b: 5.5 mm (0.217 in) dia.
Valve guide reamer  NT016	Reaming valve guide 1 or hole for oversize valve guide 2 Intake & Exhaust: d1: 6.0 mm (0.236 in) dia. d2: 10.2 mm (0.402 in) dia.

A
EM
C
D
E
F
G
H
I
J
K
L
M
N
O
P

PREPARATION

[VQ35DE]

< PREPARATION >

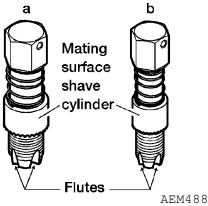
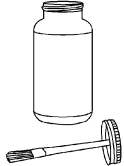
(Kent-Moore No.) Tool name	Description
<p>(J-43897-18) (J-43897-12) Oxygen sensor thread cleaner</p> 	<p>Reconditioning the exhaust system threads before installing a new oxygen sensor (Use with anti-seize lubricant shown below.) a: J-43897-18 (18 mm dia.) for zirconia oxygen sensor b: J-43897-12 (12 mm dia.) for titania oxygen sensor</p>
<p>Anti-seize lubricant (Permatex 133AR or equivalent meeting MIL specification MIL-A-907)</p> 	<p>Lubricating oxygen sensor thread cleaning tool when reconditioning exhaust system threads</p>

SYSTEM DESCRIPTION

NOISE, VIBRATION, AND HARSHNESS (NVH) TROUBLESHOOTING

NVH Troubleshooting - Engine Noise

INFOID:000000007420268

A

EM

C

D

E

F

G

H

I

J

K

L

M

N

O

P

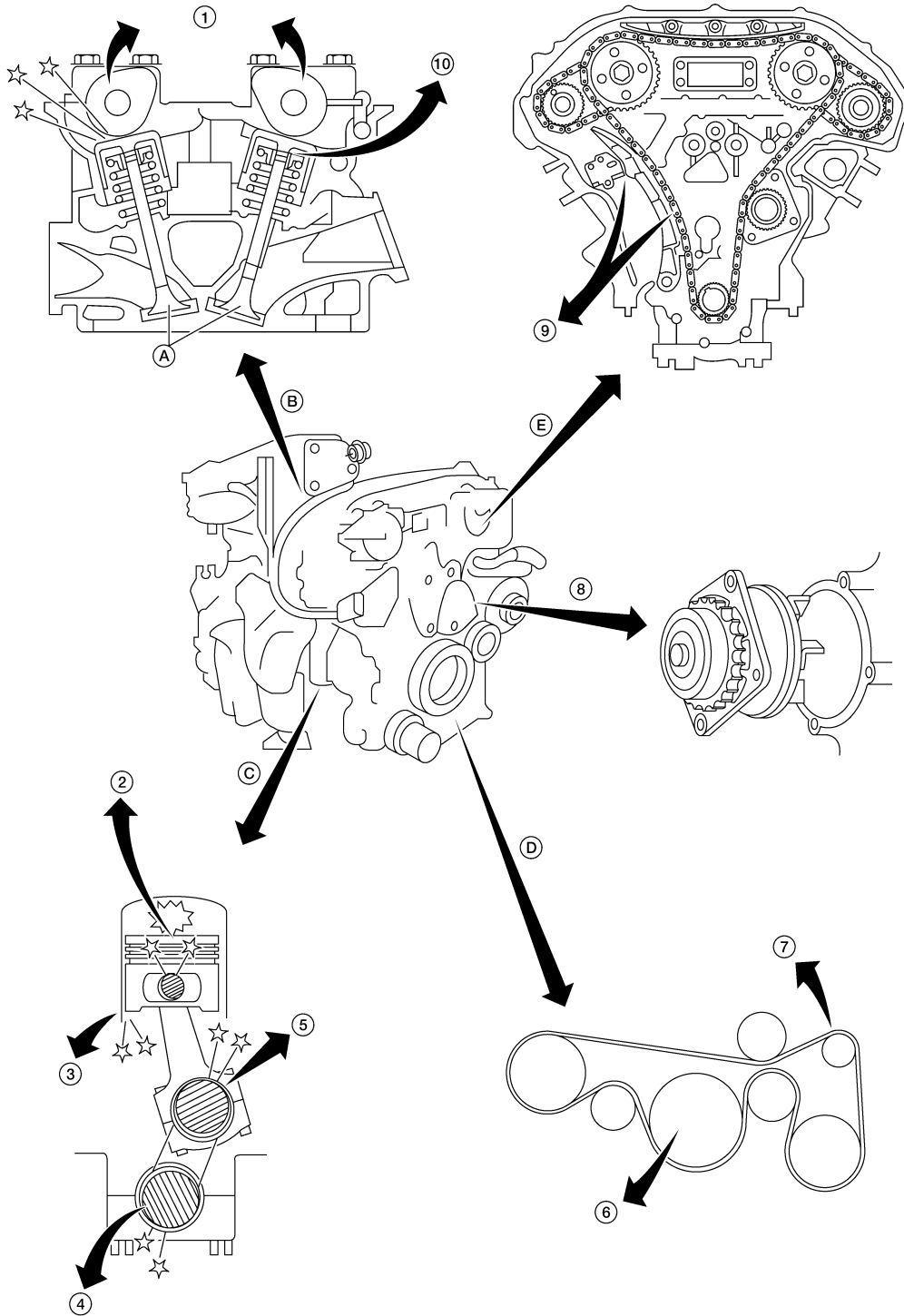

AWBIA00222Z

- 1. Camshaft bearing noise
- 2. Piston pin noise
- 3. Piston slap noise
- 4. Main bearing noise
- 5. Connecting rod bearing noise
- 6. Drive belt noise (Sticking/Slipping)
- 7. Drive belt noise (Slipping)
- 8. Water pump noise
- 9. Timing chain and chain tensioner noise

NOISE, VIBRATION, AND HARSHNESS (NVH) TROUBLESHOOTING

< SYSTEM DESCRIPTION >

[VQ35DE]

- | | | |
|-----------------------|---------------|--------------------|
| 10. Tappet noise | A. Valve | B. Valve mechanism |
| C. Rotation mechanism | D. Drive belt | E. Timing chain |

Use the Chart Below to Help You Find the Cause of the Symptom

INFOID:000000007420269

1. Locate the area where noise occurs.
2. Confirm the type of noise.
3. Specify the operating condition of engine.
4. Check specified noise source. Repair or replace the identified part as necessary.

Location of noise	Type of noise	Operating condition of engine						Source of noise	Check item	Reference page
		Before warm-up	After warm-up	When starting	When idling	When racing	While driving			
Top of engine Rocker cover Cylinder head	Ticking or clicking	C	A	—	A	B	—	Tappet noise	Valve clearance	EM-127
	Rattle	C	A	—	A	B	C	Camshaft bearing noise	Camshaft journal clearance Camshaft runout	EM-184
Crankshaft pulley Cylinder block (Side of engine) Oil pan	Slap or knock	—	A	—	B	B	—	Piston pin noise	Piston and piston pin clearance Connecting rod bushing clearance	EM-131
	Slap or rap	A	—	—	B	B	A	Piston slap noise	Piston-to-bore clearance Piston ring side clearance Piston ring end gap Connecting rod bend and torsion	EM-214
	Knock	A	B	C	B	B	B	Connecting rod bearing noise	Connecting rod bushing clearance (Small end) Connecting rod bearing clearance (Big end)	EM-214
	Knock	A	B	—	A	B	C	Main bearing noise	Main bearing oil clearance Crankshaft runout	EM-214
Front of engine Timing chain cover	Tapping or ticking	A	A	—	B	B	B	Timing chain and chain tensioner noise	Timing chain cracks and wear Timing chain tensioner operation	EM-171
Front of engine	Squeaking or fizzing	A	B	—	B	—	C	Drive belts (Sticking or slipping)	Drive belts deflection	EM-123
	Creaking	A	B	A	B	A	B	Drive belts (Slipping)	Idler pulley bearing operation	
	Squall Creak	A	B	—	B	A	B	Water pump noise	Water pump operation	CO-43

A: Closely related B: Related C: Sometimes related —: Not related

SPARK PLUG

< PERIODIC MAINTENANCE >

[VQ35DE]

PERIODIC MAINTENANCE

SPARK PLUG

Removal and Installation

INFOID:000000007420270

A

EM

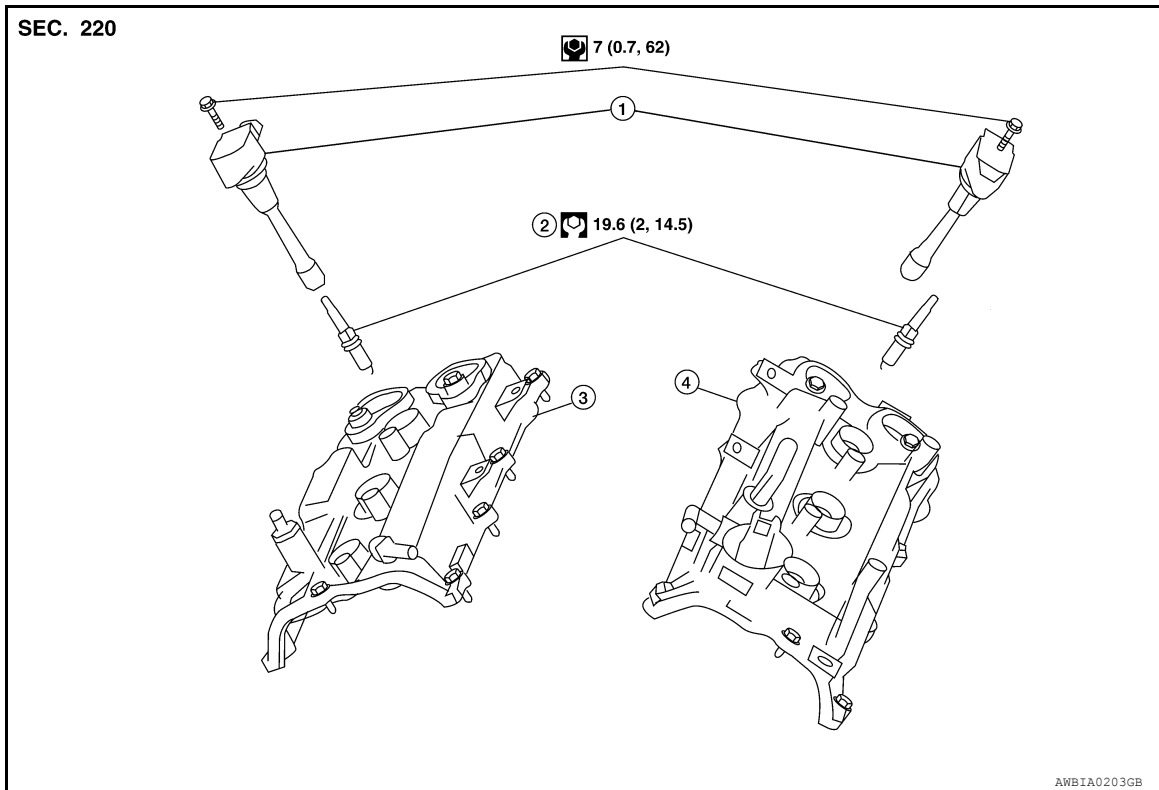

- 1. Ignition coil
- 4. Rocker cover LH

- 2. Spark plug

- 3. Rocker cover RH

REMOVAL

1. Remove the ignition coil. Refer to [EM-150. "Removal and Installation LH"](#) (LH) and [EM-150. "Removal and Installation RH"](#) (RH).
2. Remove the spark plug with a suitable tool.

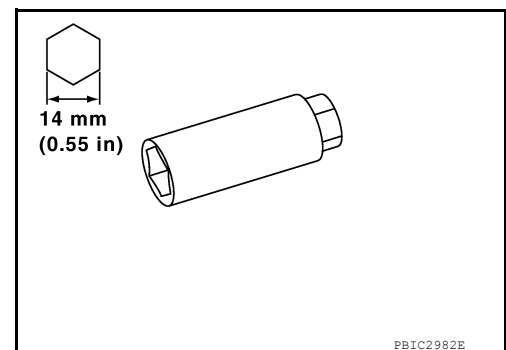

INSPECTION AFTER REMOVAL

C

D

E

F

G

H

I

J

K

L

M

N

O

P

SPARK PLUG

[VQ35DE]

< PERIODIC MAINTENANCE >

- Do not use a wire brush for cleaning the spark plugs. Replace as necessary.

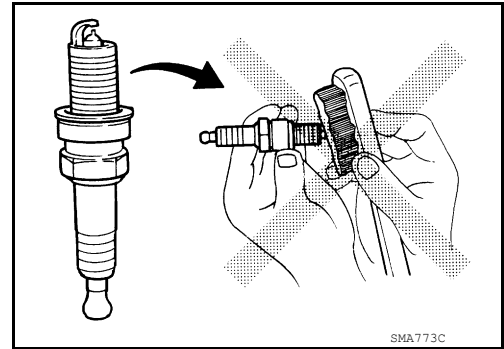

- If plug is covered with carbon, a spark plug cleaner may be used.

Cleaner air pressure : less than 588 kPa (5.88 bar, 6 kg/cm², 85 psi)

Cleaning time : less than 20 seconds

- Checking and adjusting plug gap is not required between change intervals. If the gap is out of specification, replace the spark plug.

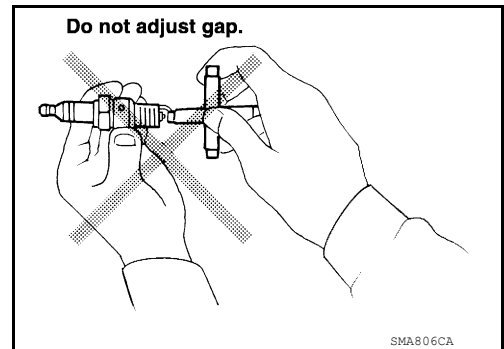

INSTALLATION

Installation is in the reverse order of removal.

Standard type*	DENSO
	FXE22HR-11
Gap (nominal)	1.1 mm (0.043 in)

*: Always check with the Parts Department for the latest parts information.

DRIVE BELTS

Checking Drive Belts

INFOID:000000007420271

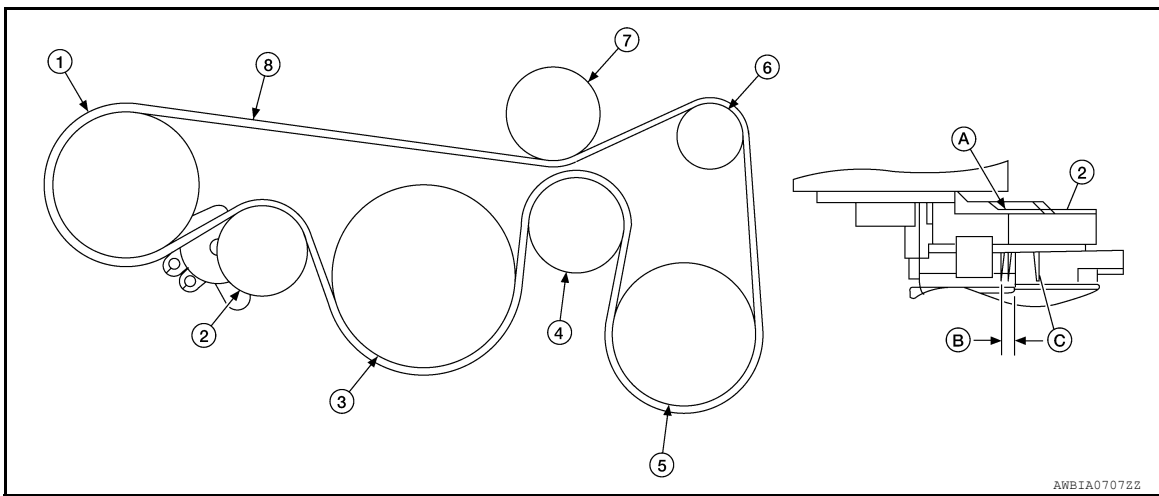

- | | | |
|--------------------------------------|------------------------------|---------------------|
| 1. Power steering pump | 2. Drive belt auto-tensioner | 3. Crankshaft |
| 4. Idler pulley | 5. A/C compressor pulley | 6. Generator pulley |
| 7. Idler pulley | 8. Drive belt | A. Indicator |
| B. Possible use range (for new belt) | C. Belt replacement | |

WARNING:

Inspect and check the drive belts with the engine off.

1. Inspect belt for cracks, fraying, wear or oil adhesion. If necessary, replace with a new one.
2. Rotate the crankshaft pulley two times then check the belt tension.

NOTE:

- Inspect drive belt tension when engine is cold.

Tension Adjustment

INFOID:000000007420272

- Belt tension is not manually adjustable, it is automatically adjusted by the drive belt auto-tensioner.

Removal and Installation

INFOID:000000007420273

REMOVAL

1. Remove the front RH wheel and tire. Refer to [WT-68, "Adjustment"](#).
2. Remove the fender protector side cover (RH). Refer to [EXT-22, "Removal and Installation"](#) (Coupe models) or [EXT-46, "Removal and Installation"](#) (Sedan models).
3. While securely holding the hexagonal part in pulley center of drive belt auto-tensioner, move in the direction of arrow (loosening direction of tensioner) using suitable tool.

WARNING:

Avoid placing hand in a location where pinching may occur if the holding tool accidentally comes off.

CAUTION:

Do not loosen the auto-tensioner pulley bolt. (Do not turn it counterclockwise.) If turned counterclockwise, the complete auto-tensioner must be replaced as a unit, including pulley.

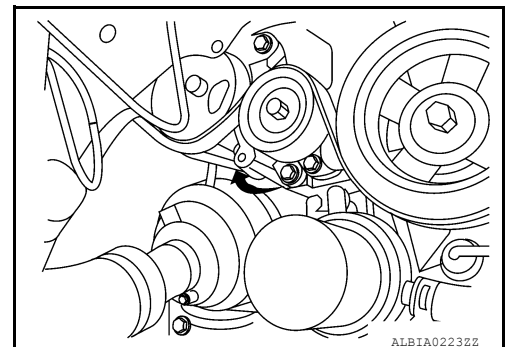

4. Insert a rod approximately 6 mm (0.24 in) in diameter through the rear of tensioner into retaining boss to lock tensioner pulley.
 - Leave tensioner pulley arm locked until belt is installed again.
5. Loosen drive belt from water pump pulley and then remove it from the other pulleys.

A
EM
C
D
E
F
G
H
I
J
K
L
M
N
O
P

INSTALLATION

1. Install the drive belt onto all of the pulleys.
CAUTION:
Confirm belts are completely set on the pulleys.
2. Release tensioner, and apply tension to belt.
WARNING:
Avoid placing hand in a location where pinching may occur if the holding tool accidentally comes off.
CAUTION:
Do not loosen the auto-tensioner pulley bolt. (Don't turn it counterclockwise. If turned counterclockwise, the complete auto-tensioner must be replaced as a unit, including pulley.)
3. Turn crankshaft pulley clockwise several times to equalize tension between each pulley.
4. Confirm tension of belt at indicator is within the allowable use range. Refer to [EM-16. "Checking Drive Belts"](#).
5. Install the fender protector side cover (RH). Refer to [EXT-22. "Removal and Installation"](#) (Coupe models) or [EXT-46. "Removal and Installation"](#) (Sedan models).
6. Install the front RH wheel and tire. Refer to [WT-68. "Adjustment"](#).

Removal and Installation of Drive Belt Auto-tensioner

INFOID:000000007420274

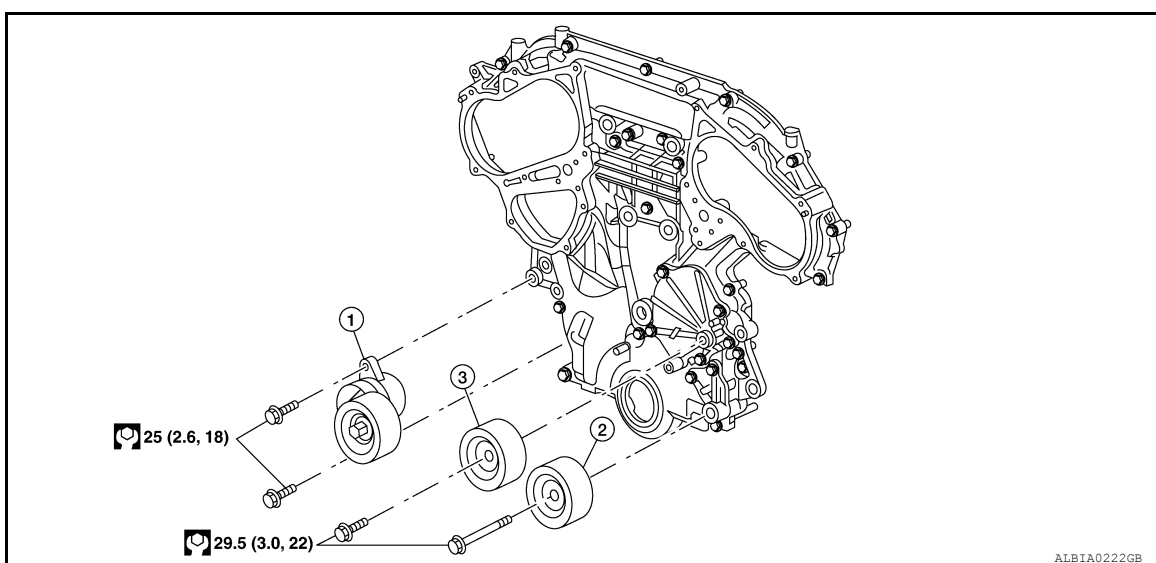

1. Drive belt auto-tensioner

2. Idler pulley

3. A/C idler pulley

REMOVAL

CAUTION:

The complete auto-tensioner must be replaced as a unit, including the pulley.

1. Remove the front RH wheel and tire. Refer to [WT-68. "Adjustment"](#).
2. Remove the fender protector side cover (RH). Refer to [EXT-22. "Removal and Installation"](#) (Coupe models) or [EXT-46. "Removal and Installation"](#) (Sedan models).
3. Remove the drive belt. Refer to [EM-123. "Removal and Installation"](#).
 - Insert a rod approximately 6 mm (0.24 in) in diameter through the rear of tensioner into the retaining boss to lock tensioner pulley.
4. Remove the drive belt auto-tensioner, with power tool.

CAUTION:

Do not loosen the auto-tensioner pulley bolt. Don't turn it counterclockwise. If turned counterclockwise, the complete auto-tensioner must be replaced as a unit, including pulley.

INSTALLATION

Installation is in the reverse order of removal.

DRIVE BELTS

< PERIODIC MAINTENANCE >

[VQ35DE]

CAUTION:

- If there is damage greater than peeled paint, replace drive belt auto-tensioner units.
- Install the drive belt auto-tensioner carefully so as not to damage the water pump pulley.
- Do not swap the pulley between the new and old auto-tensioner units.

A

EM

C

D

E

F

G

H

I

J

K

L

M

N

O

P

AIR CLEANER FILTER

Removal and Installation

INFOID:000000007420275

SEC. 118 • 148 • 165

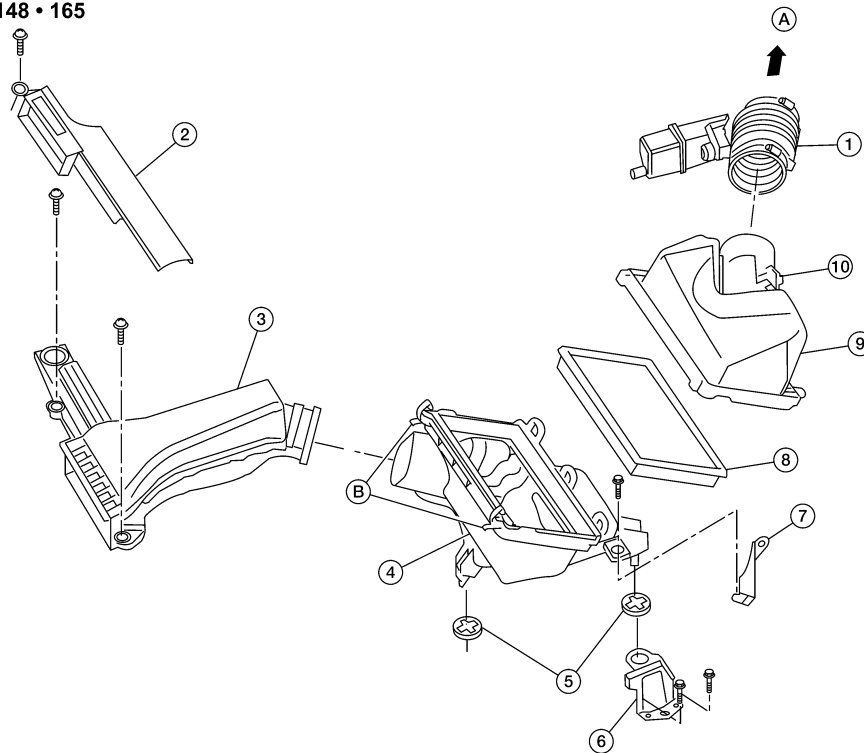

AWBIA05692Z

- | | | |
|-----------------------------|--|--------------------------------------|
| 1. Air duct hose | 2. Duct sub-cover | 3. Front air duct |
| 4. Air cleaner case (lower) | 5. Grommets | 6. Air cleaner case mounting bracket |
| 7. Bracket | 8. Air cleaner filter | 9. Air cleaner case (upper) |
| 10. Mass air flow sensor | A. To electric throttle control actuator | B. Air cleaner case side clips |

CHANGING THE AIR CLEANER FILTER

CAUTION:

It is not necessary to remove the front air duct to replace the air cleaner filter.

1. Disconnect mass air flow sensor electrical connector.
2. Unhook the air cleaner case side clips.
3. Remove air cleaner case (upper).
4. Remove the air cleaner filter.
5. Install a new air cleaner filter.
6. Install air cleaner case (upper).
7. Lock the air cleaner case side clips.
8. Connect mass air flow sensor electrical connector.

CAMSHAFT VALVE CLEARANCE

< PERIODIC MAINTENANCE >

[VQ35DE]

CAMSHAFT VALVE CLEARANCE

Valve Clearance

INFOID:000000007420276

CHECKING

- Perform inspection as follows after removal, installation or replacement of camshaft or valve related parts, or if there is unusual engine conditions regarding valve clearance.

Check valve clearance while engine is cold and not running.

1. Remove the air duct with air cleaner case, collectors, hoses, wires, harnesses, and connectors.
 2. Remove the intake manifold collectors.
 3. Remove the ignition coils and spark plugs.
 4. Remove the rocker covers.
-
5. Set No.1 cylinder at TDC on its compression stroke.
 - Align pointer (A) with TDC mark on crankshaft pulley.

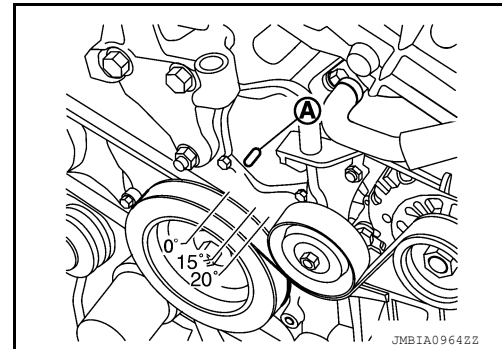
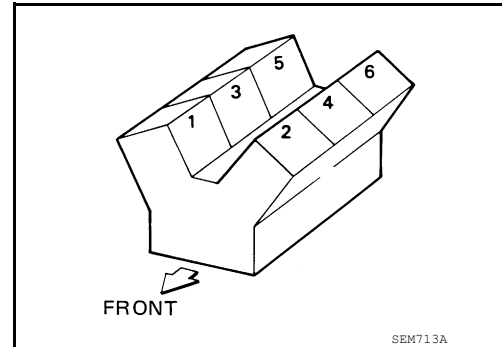

- Check that the valve lifters on No.1 cylinder are loose and valve lifters on No.4 are tight. If not, turn the crankshaft one full revolution (360°) and align as shown.

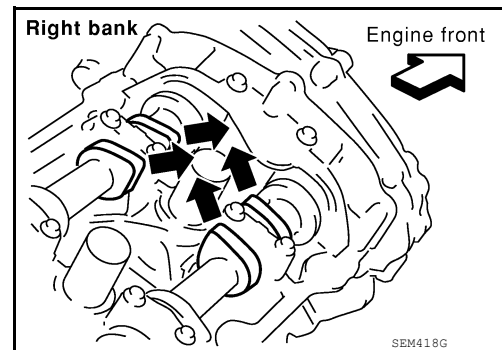

A
EM
C
D
E
F
G
H
I
J
K
L
M
N
O
P

CAMSHAFT VALVE CLEARANCE

[VQ35DE]

< PERIODIC MAINTENANCE >

6. Check only the valves as shown.

Crank Position	Valve No. 1	Valve No. 2	Valve No. 3	Valve No. 6
No. 1 TDC	Intake	Exhaust	Exhaust	Intake

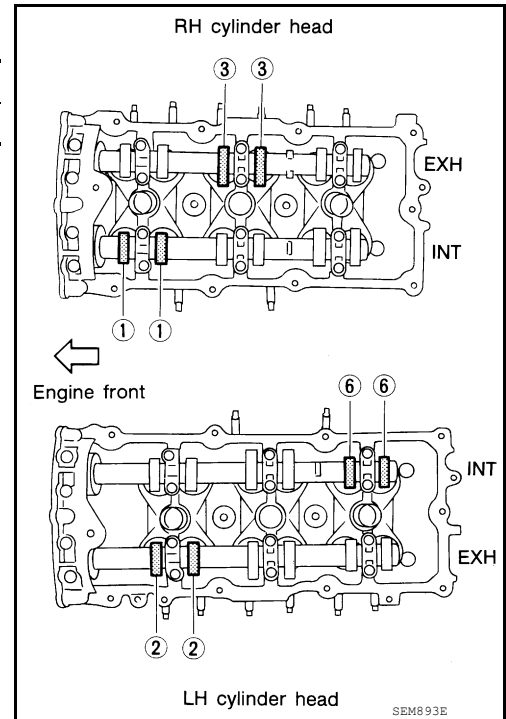

- Using a feeler gauge, measure the clearance between the valve lifter and camshaft.
- Record any valve clearance measurements which are out of specification. They will be used later to determine the required replacement lifter size.

Valve Clearance for Checking (cold)

Intake : 0.26 - 0.34 mm (0.010 - 0.013 in)

Exhaust : 0.29 - 0.37 mm (0.011 - 0.015 in)

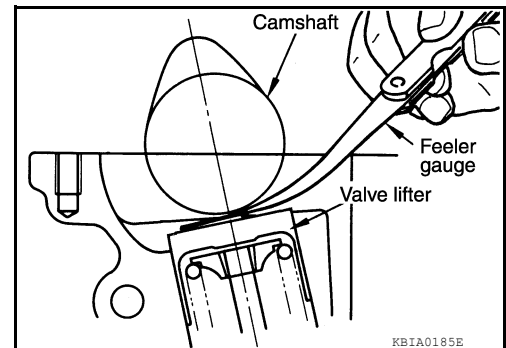
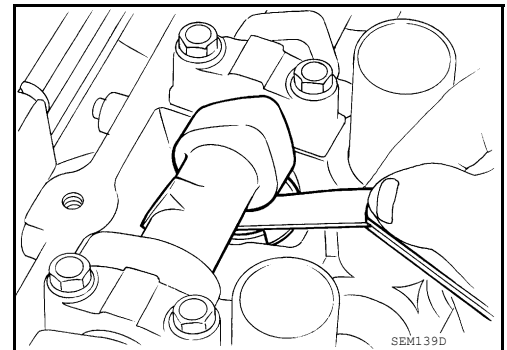

7. Turn crankshaft 240°.
8. Set No.3 cylinder at TDC on its compression stroke.

CAMSHAFT VALVE CLEARANCE

[VQ35DE]

< PERIODIC MAINTENANCE >

9. Check only those valves as shown.

Crank Position	Valve No. 2	Valve No. 3	Valve No. 4	Valve No. 5
No. 3 TDC	Intake	Intake	Exhaust	Exhaust

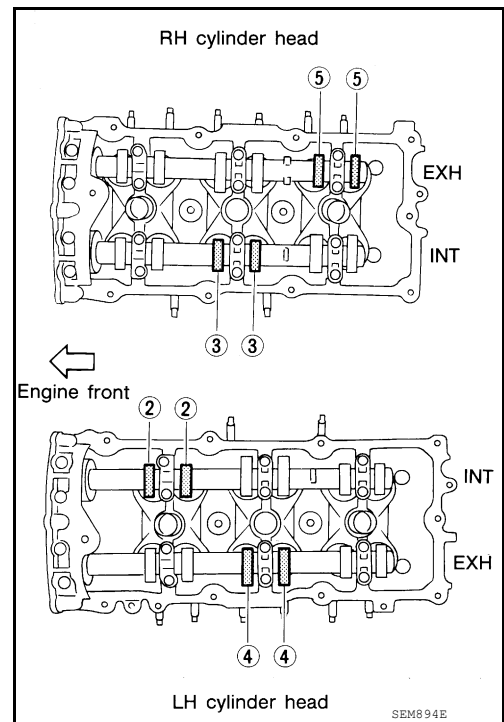

10. Turn the crankshaft 240° and align as above.
11. Set No.5 cylinder at TDC on its compression stroke.
12. Check only those valves as shown.

Crank Position	Valve No. 1	Valve No. 4	Valve No. 5	Valve No. 6
No. 5 TDC	Exhaust	Intake	Intake	Exhaust

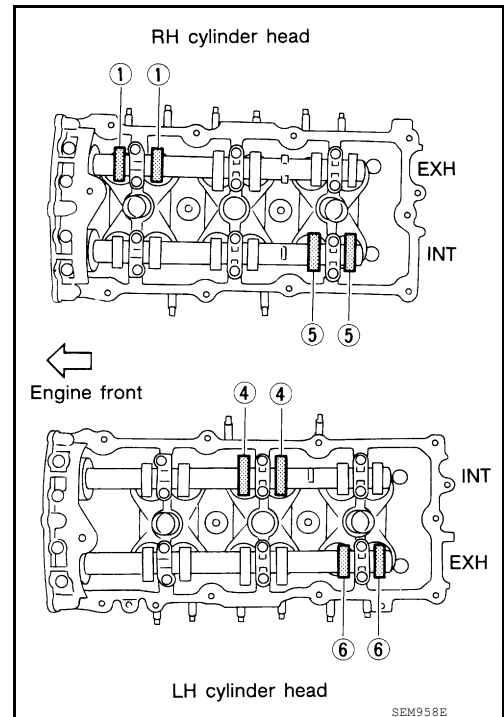

13. If all valve clearances are within specification, install the following components. If the valve clearances are out of specification, adjust the valve clearances.
 - Intake manifold collectors
 - Rocker covers
 - All spark plugs
 - All ignition coils

VALVE ADJUSTING

CAMSHAFT VALVE CLEARANCE

< PERIODIC MAINTENANCE >

[VQ35DE]

CAUTION:

Adjust valve clearance while engine is cold.

NOTE:

- Perform adjustment by selecting the correct head thickness of the valve lifter (adjusting shims are not used).
- The specified valve lifter thickness is the dimension at normal temperatures. Ignore dimensional differences caused by temperature. Use specifications for hot engine condition to confirm valve clearances.

1. Remove the camshaft.
2. Remove the valve lifter that was measured as being outside the standard specifications.
3. Measure the center thickness of the removed lifter with a micrometer, as shown.

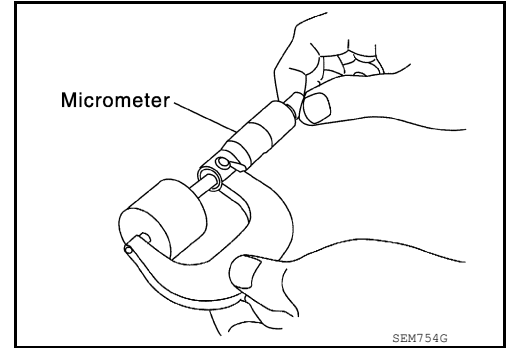

4. Use the equation below to calculate the replacement valve lifter thickness.

Valve lifter thickness calculation equation: $t = t1 + (C1 - C2)$

t = thickness of the replacement lifter

t1 = thickness of the removed lifter

C1 = measured valve clearance

C2 = standard valve clearance

- The thickness of the new valve lifter can be identified by the stamp mark on the reverse side (inside the lifter).
- Available thickness of the valve lifter (factory setting): 7.88 - 8.40 mm (0.3102 - 0.3307 in), in 0.02 mm (0.0008 in) increments, in 27 sizes (intake / exhaust). Refer to [EM-237, "Camshaft"](#).

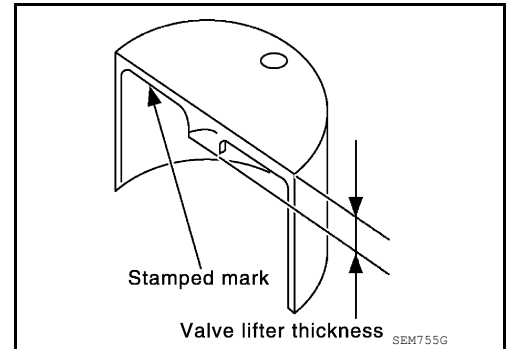

5. Install the selected replacement valve lifter.
6. Install the camshaft.
7. Rotate the crankshaft a few turns by hand.
8. Confirm that the valve clearances are within specification.
9. After the engine has been run to full operating temperature, confirm that the valve clearances are within specification.

Standard Valve Clearance	Cold	Hot* (reference data)
Intake	0.26 - 0.34 mm (0.010 - 0.013 in)	0.304 - 0.416 mm (0.012 - 0.016 in)
Exhaust	0.29 - 0.37 mm (0.011 - 0.015 in)	0.308 - 0.432 mm (0.012 - 0.017 in)

* Approximately 80°C (176°F)

COMPRESSION PRESSURE

< PERIODIC MAINTENANCE >

[VQ35DE]

COMPRESSION PRESSURE

On-Vehicle Service

INFOID:000000007420277

CHECKING COMPRESSION PRESSURE

1. Run the engine until it reaches normal operating temperature.
2. Turn the ignition switch to OFF.
3. Release fuel pressure and leave the fuel pump electrically disconnected.
Refer to [EC-700, "Inspection"](#).
4. Remove all six spark plugs.
Refer to [EM-121, "Removal and Installation"](#).
5. Attach a compression tester to No. 1 cylinder.
6. Depress accelerator pedal fully to keep the electric throttle control actuator butterfly-valve wide open to maximize air intake flow.
7. Crank the engine and record the highest gauge indication.
8. Repeat the measurement on each cylinder (steps 5 - 7).

NOTE:

Always use a fully charged battery to obtain specified engine speed.

Unit: kPa (bar, kg/cm², psi)/rpm

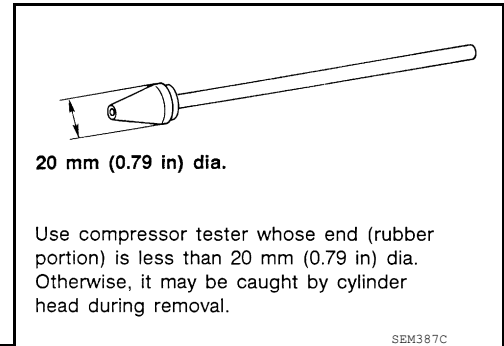

Standard	Minimum	Difference limit between cylinders
1,275 (12.75, 13.0, 185)/300	981 (9.81, 10.0, 142)/300	98 (0.98, 1.0, 14)/300

9. If compression in one or more cylinders is low:
 - a. Pour a small amount of engine oil into cylinders through the spark plug holes.
 - b. Retest compression (steps 5 - 8).
 - If adding oil helps raise compression pressure, then the piston rings may be worn or damaged. If so, replace piston rings after checking piston.
 - If the pressure stays low, a valve may be sticking or is seating improperly. Inspect and repair the valve and/or valve seat. Refer to [EM-202, "Inspection After Disassembly"](#). If the valve and/or valve seat is damaged excessively, replace as necessary.
 - If compression stays low in two or more cylinders that are next to each other:
 - The cylinder head gasket may be leaking.
 - Both cylinders may have valve component damage. Inspect and repair as necessary.

AIR CLEANER AND AIR DUCT

< REMOVAL AND INSTALLATION >

[VQ35DE]

REMOVAL AND INSTALLATION

AIR CLEANER AND AIR DUCT

Removal and Installation

INFOID:000000007420278

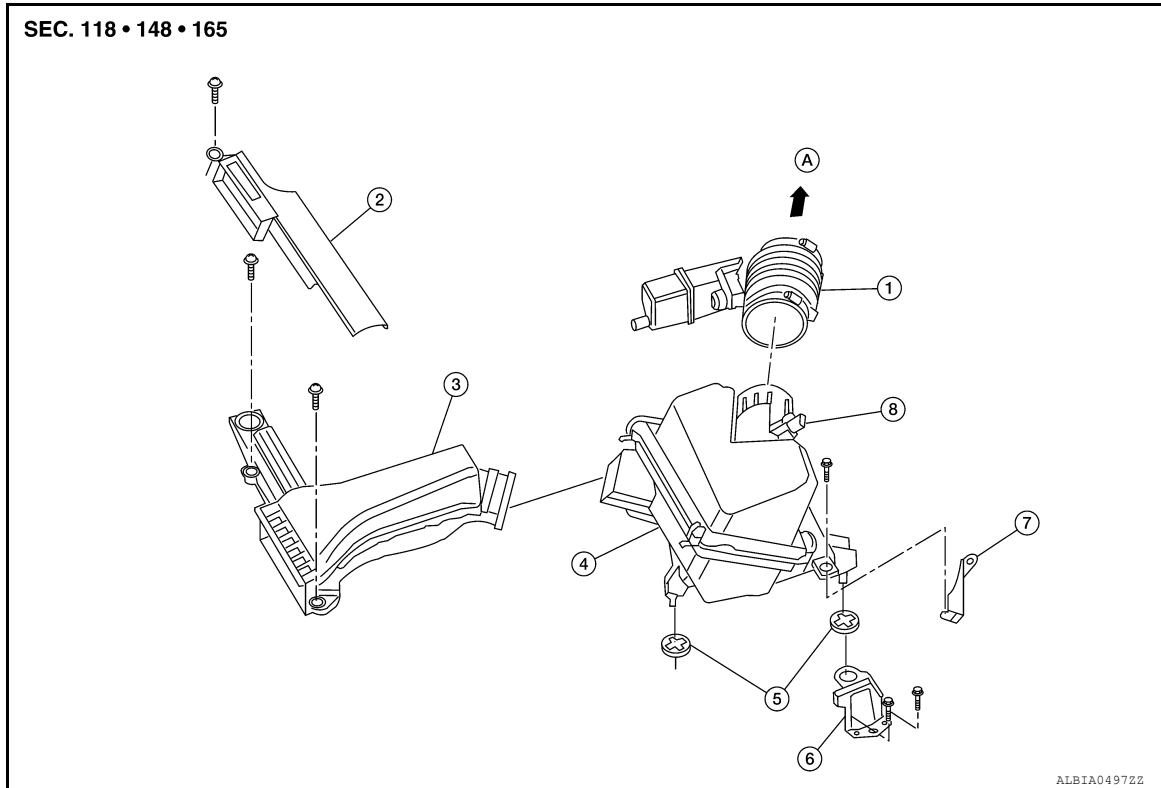

- | | | |
|-------------------------|-------------------------|--|
| 1. Air duct hose | 2. Duct sub-cover | 3. Front air duct |
| 4. Air cleaner assembly | 5. Grommets | 6. Air cleaner bracket |
| 7. Bracket | 8. Mass air flow sensor | A. To electric throttle control actuator |

REMOVAL

1. Remove engine room cover.
2. Remove front air duct.
3. Disconnect the blow-by hose.
4. Disconnect the tube clamp at the electric throttle control actuator and at the air duct hose.
5. Remove air duct hose.
6. Disconnect mass air flow sensor.
7. Remove mass air flow sensor from air cleaner assembly, as necessary.

CAUTION:

Handle mass air flow sensor with care.

- Do not shock it.
- Do not disassemble it.
- Do not touch its sensor.

8. Remove air cleaner assembly.

INSTALLATION

Installation is in the reverse order of removal.

INTAKE MANIFOLD COLLECTOR

< REMOVAL AND INSTALLATION >

[VQ35DE]

INTAKE MANIFOLD COLLECTOR

Removal and Installation

INFOID:000000007420279

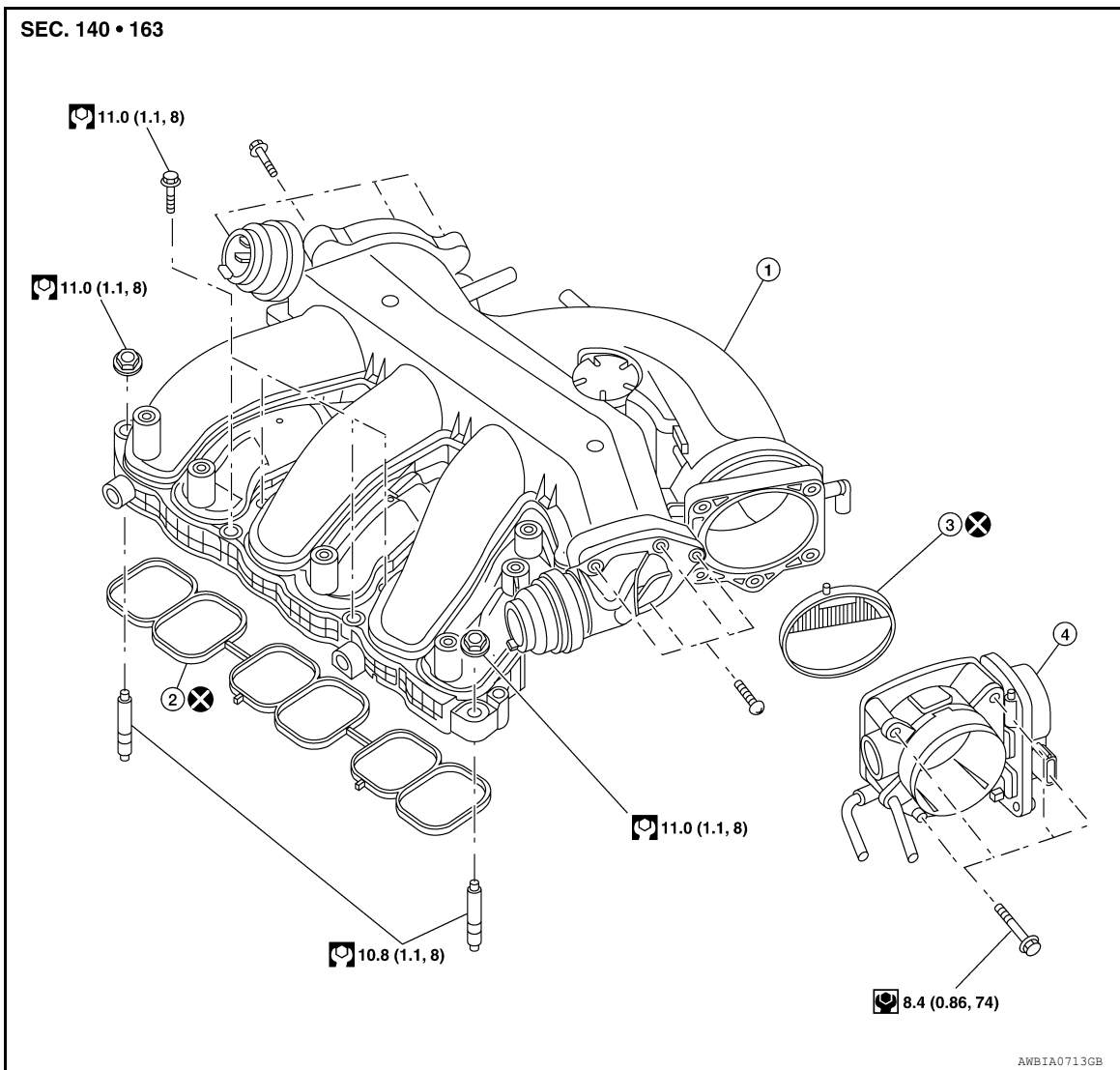

1. Intake manifold collector
2. Gasket

2. Gasket

3. Gasket

4. Electric throttle control actuator

CAUTION:

Do not remove power valves.

REMOVAL

WARNING:

To avoid the danger of being scalded, do not drain the coolant when the engine is hot.

1. Remove the cowl top. Refer to [EXT-21, "Removal and Installation"](#) (Coupe models) or [EXT-45, "Removal and Installation"](#) (Sedan models).
2. Remove the strut tower bar. Refer to [FSU-14, "Exploded View"](#).
3. Remove the engine room cover.
4. Remove front air duct and air duct hose. Refer to [EM-132, "Removal and Installation"](#).
5. Partially drain the coolant when the engine is cool. Refer to [CO-36, "Changing Engine Coolant"](#).

NOTE:

This step is only required when removing electric throttle control actuator from the vehicle.

INTAKE MANIFOLD COLLECTOR

[VQ35DE]

< REMOVAL AND INSTALLATION >

6. Remove the electric throttle control actuator bolts in the reverse order as shown and remove the electric throttle control actuator and position aside.

CAUTION:

- Handle carefully to avoid any shock to the electric throttle control actuator.
- Do not disassemble.

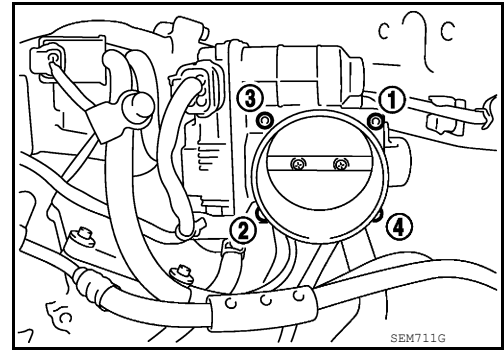

7. Disconnect the following:
- Power brake booster vacuum hose
 - Fuel injector electrical connectors
 - PCV hose
 - Electric throttle control actuator electrical connector
 - EVAP canister purge hose
 - VIAS control solenoid valve

CAUTION:

- Cover any engine openings to avoid the entry of any foreign material.

8. Remove the EVAP canister purge volume solenoid valve bracket bolt. Position the valve aside.
9. Loosen the intake manifold collector bolts in the order as shown using power tool, and remove the intake manifold collector and gasket.

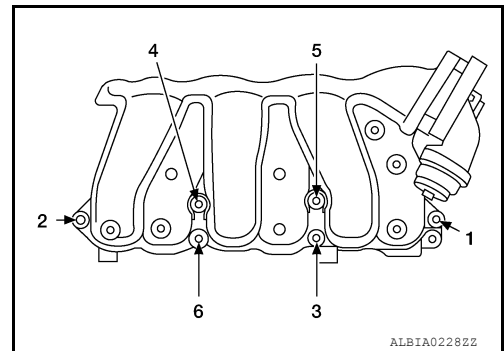

10. If necessary remove the following components:
- VIAS control solenoid valve
 - EVAP canister purge volume control solenoid valve

INSTALLATION

Installation is in the reverse order of removal.

- Tighten intake manifold collector bolts in the order as shown.

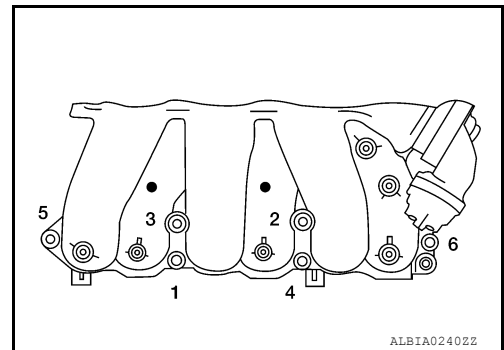

INTAKE MANIFOLD COLLECTOR

< REMOVAL AND INSTALLATION >

[VQ35DE]

- Tighten electric throttle control actuator bolts in the order shown.

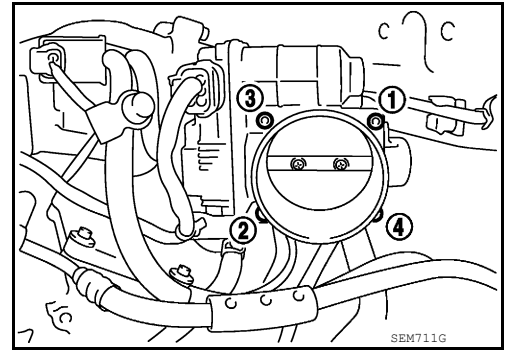

NOTE:

After installation, it is necessary to re-calibrate the electric throttle control actuator as follows:

1. Perform the "Throttle Valve Closed Position Learning" when harness connector of the electric throttle control actuator is disconnected. Refer to [EC-335. "THROTTLE VALVE CLOSED POSITION LEARNING : Special Repair Requirement"](#).
2. Perform the "idle Air Volume Learning" when the electric throttle control actuator is replaced. Refer to [EC-335. "IDLE AIR VOLUME LEARNING : Special Repair Requirement"](#).

A
EM
C
D
E
F
G
H
I
J
K
L
M
N
O
P

INTAKE MANIFOLD

< REMOVAL AND INSTALLATION >

[VQ35DE]

INTAKE MANIFOLD

Removal and Installation

INFOID:000000007420280

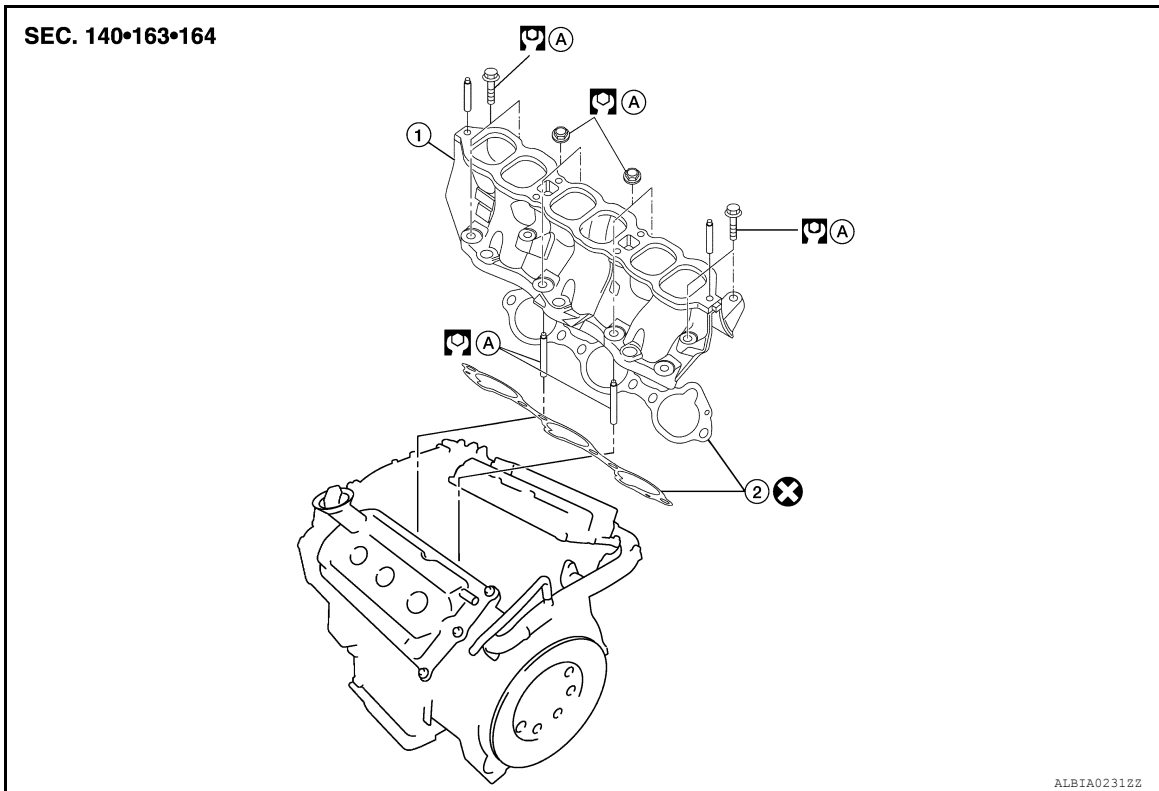

1. Intake manifold

2. Gasket

A. Follow installation procedure

REMOVAL

WARNING:

To avoid the danger of being scalded, do not drain the coolant when the engine is hot.

1. Release the fuel pressure. Refer to [EC-700, "Inspection"](#).
2. Disconnect the battery negative terminal. Refer to [PG-68, "Removal and Installation \(Battery\)"](#) (Coupe models) of [PG-140, "Removal and Installation \(Battery\)"](#) (Sedan models).
3. Remove intake manifold collector. Refer to [EM-133, "Removal and Installation"](#).
4. Disconnect fuel tube quick connector at vehicle piping side.
5. To remove the quick connector cap (1), hold the sides of the connector (A), push in the tabs (2) and pull out the tube (3).

CAUTION:

- The tube can be removed when the tabs are completely depressed. Do not twist it more than necessary.
- Do not use any tools to remove the quick connector.
- Keep the resin tube away from heat. Be especially careful when welding near the tube.
- Prevent acid liquids such as battery electrolyte, etc. from getting on the resin tube.
- Do not bend or twist the tube during removal or installation.
- Do not remove the remaining retainer on the tube.
- When the tube is replaced, also replace the retainer with a new one.

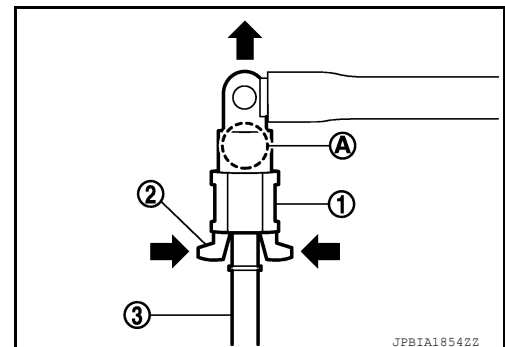

INTAKE MANIFOLD

[VQ35DE]

< REMOVAL AND INSTALLATION >

- To keep the connecting portion clean and to avoid damage and foreign materials entering, cover the ends of the fuel tubes with plastic bags or something similar.

NOTE:

If the connector and the tube are stuck together, push and pull several times until they start to move. Then disconnect them by pulling.

6. Remove the fuel rail with the fuel injectors attached, from the intake manifold. Remove the fuel injector O-rings and use new O-rings for installation.

CAUTION:

Do not reuse O-rings.

7. Loosen the bolts in the order as shown, and remove the intake manifold with power tool.

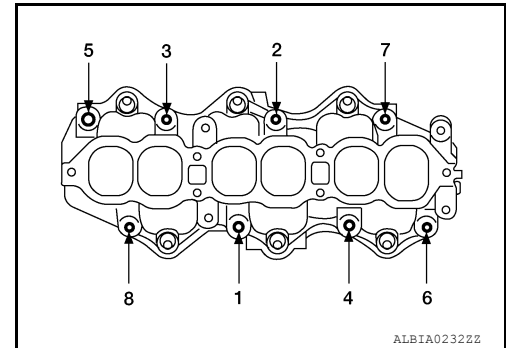
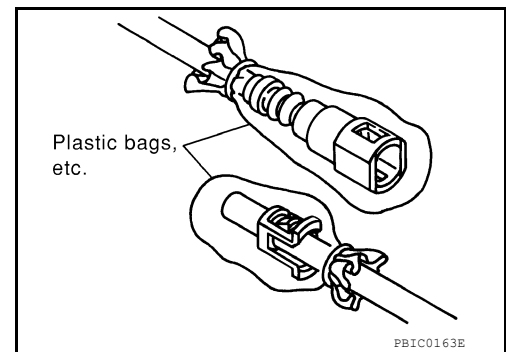

INSPECTION AFTER REMOVAL

Surface Distortion

- Using straightedge and feeler gauge, inspect the surface distortion of the intake manifold.

Standard : 0.1 mm (0.004 in)

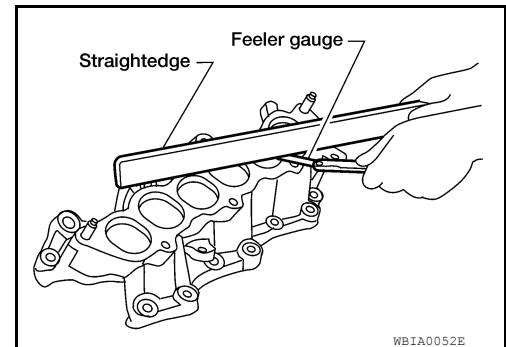

INSTALLATION

Installation is in the reverse order of removal. Follow the procedure below for specific tightening sequences and procedures.

- Install intake manifold bolts in two steps in the numerical order as shown.

Step 1 : 7.3 N·m (0.74 kg-m, 65 in-lb)

Step 2 : 25.5 N·m (2.6 kg-m, 19 ft-lb)

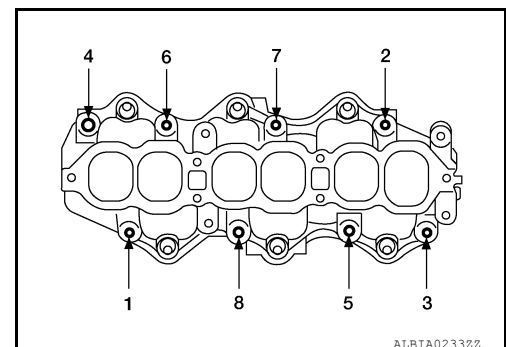

NOTE:

After installation, it is necessary to re-calibrate the electric throttle control actuator as follows:

1. Perform the "Throttle Valve Closed Position Learning" when harness connector of the electric throttle control actuator is disconnected. Refer to [EC-335. "THROTTLE VALVE CLOSED POSITION LEARNING : Special Repair Requirement"](#).

INTAKE MANIFOLD

[VQ35DE]

< REMOVAL AND INSTALLATION >

2. Perform the "Idle Air Volume Learning" when the electric throttle control actuator is replaced. Refer to [EC-335, "IDLE AIR VOLUME LEARNING : Special Repair Requirement"](#).
 - Install the quick connector as follows:
 - Make sure no foreign substances are deposited in and around the fuel tube and quick connector and that there is no damage.
 - Align the center to insert the quick connector straight onto the fuel tube.
 - Insert the fuel tube until a click is heard.
 - Install the quick connector cap on the quick connector joint. Align the arrow mark on the quick connector cap to the upper side.
 - Install the fuel hose into the hose clamp.

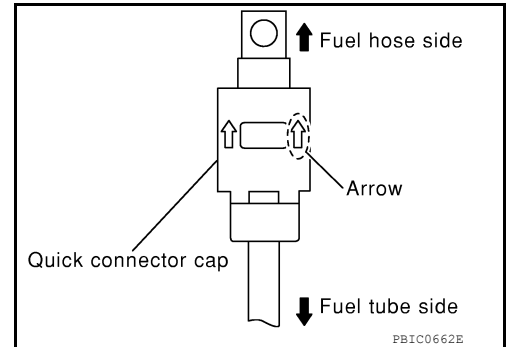

INSPECTION AFTER INSTALLATION

Make sure there are no fuel leaks.

1. Apply pressure to fuel lines by turning ignition switch ON (with engine stopped). Then check for fuel leaks at connections.
2. Start the engine and rev it up and check for fuel leaks at connections.

WARNING:

Do not touch engine immediately after stopping as engine is extremely hot.

NOTE:

Use mirrors for checking on connections out of the direct line of sight.

EXHAUST MANIFOLD AND THREE WAY CATALYST

< REMOVAL AND INSTALLATION >

[VQ35DE]

EXHAUST MANIFOLD AND THREE WAY CATALYST

Exploded View

INFOID:00000009316297

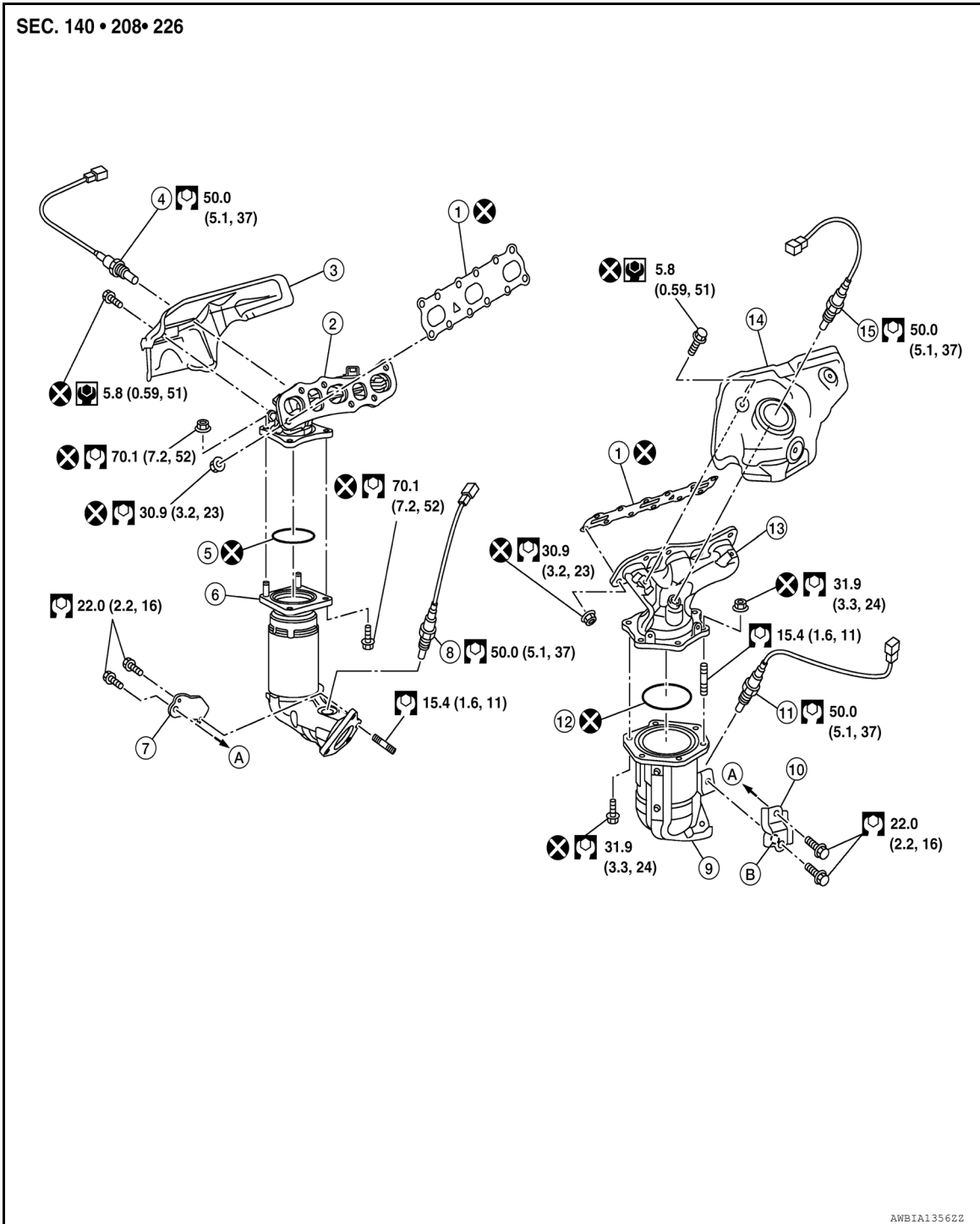

- | | | |
|---|---------------------------------------|--------------------------------------|
| 1. Gasket | 2. Exhaust manifold (RH) | 3. Exhaust manifold heat shield (RH) |
| 4. Air fuel ratio sensor 1 (bank 1) | 5. Ring gasket | 6. Three way catalyst (bank 1) |
| 7. Three way catalyst support (bank 1) | 8. Heated oxygen sensor 2 (bank 1) | 9. Three way catalyst (bank 2) |
| 10. Three way catalyst support (bank 2) | 11. Heated oxygen sensor 2 (bank 2) | 12. Ring gasket |
| 13. Exhaust manifold (LH) | 14. Exhaust manifold heat shield (LH) | 15. Air fuel ratio sensor 1 (bank 2) |
| A. To oil pan (upper) | B. Upper mark | |

EXHAUST MANIFOLD AND THREE WAY CATALYST

< REMOVAL AND INSTALLATION >

[VQ35DE]

Removal and Installation (LH)

INFOID:00000009316298

REMOVAL

WARNING:

- Perform the work when the exhaust system has completely cooled down.
- When removing the front and rear engine mount through bolts and nuts, lift the engine up slightly for safety.

NOTE:

When removing components such as hoses, tubes/lines, etc., cap or plug openings to prevent fluid from spilling.

1. Remove the air cleaner assembly, air duct hose and resonator assembly. Refer to [EM-132, "Removal and Installation"](#).
2. Remove the battery and battery tray assembly. Refer to [PG-68, "Removal and Installation \(Battery\)"](#) (coupe) and [PG-140, "Removal and Installation \(Battery\)"](#) (sedan).
3. Remove the radiator assembly. Refer to [CO-39, "Removal and Installation"](#).
4. Remove the engine cooling fan shroud and motor assembly. Refer to [CO-41, "Removal and Installation"](#).
5. Remove the front exhaust tube. Refer to [EX-13, "Exploded View"](#).
6. Remove the LH three way catalyst support brackets.
7. Remove heated oxygen sensor 2 (bank 2), air fuel ratio (A/F) sensor 1 (bank 2).
 - a. Remove harness connector of each sensor, and disconnect the harness from the bracket and middle clamp.
 - b. Remove both heated oxygen sensor 2 and air fuel ratio (A/F) sensor 1 using Tool.

Tool numbers : KV10114400 (J-38365)

: KV991J0050 (J-44626)

CAUTION:

- Be careful not to damage heated oxygen sensors 2 or air fuel ratio (A/F) sensors 1.
 - Discard any heated oxygen sensor 2 which has been dropped from a height of more than 0.5 m (19.7 in) onto a hard surface such as a concrete floor; replace with a new sensor.
8. Remove exhaust manifold heat shield (LH) and three way catalyst heat shields (LH) using power tool.
 9. Remove the three way catalyst (bank 2) by loosening the bolts first and then removing the nuts and through bolts.
 10. Loosen and remove the exhaust manifold nuts in the reverse order as shown.

⇐ : Engine front

NOTE:

Number 7 and 8 are not applicable to removal.

11. Remove the exhaust manifold (LH) and gasket.

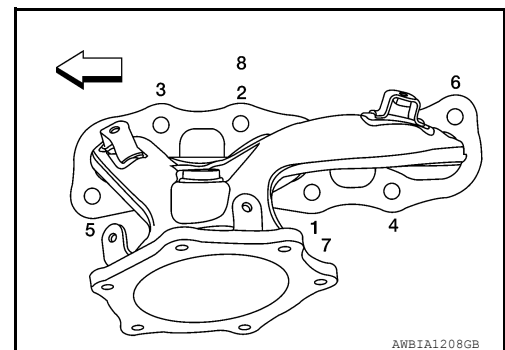

INSPECTION AFTER REMOVAL

Surface Distortion

EXHAUST MANIFOLD AND THREE WAY CATALYST

[VQ35DE]

< REMOVAL AND INSTALLATION >

- Use a reliable straightedge and feeler gauge to check the flatness of the exhaust manifold mating surfaces.

Limit : 0.3 mm (0.012 in)

- Replace the exhaust manifold if the measurement exceeds specifications.

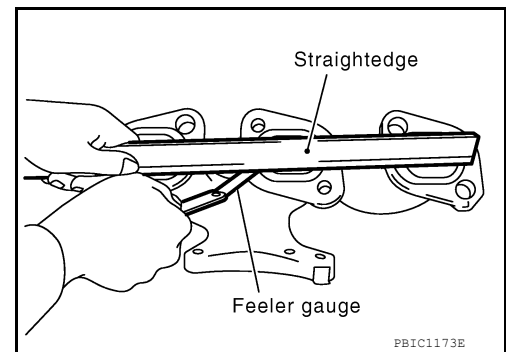

INSTALLATION

Installation is in the reverse order of removal.

1. Install the studs in the exhaust manifold (if removed), and tighten to specification.

Exhaust manifold studs : 15.4 N·m (1.6 kg-m, 11 ft-lb)

2. Install the exhaust manifold gasket in the direction shown.

CAUTION:

Do not reuse exhaust manifold gaskets.

- (A) : Bank 1
- (B) : Triangle press
- (C) : Bank 2
- ⇐ : Engine front

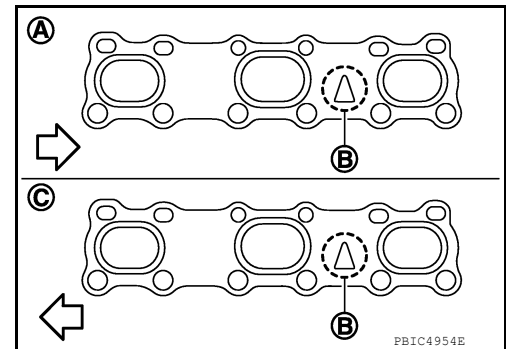

3. Install the exhaust manifold (LH) nuts and tighten to specification in the order shown.

⇐ : **Engine front**

NOTE:

Number 7 and 8 are tightened a second time.

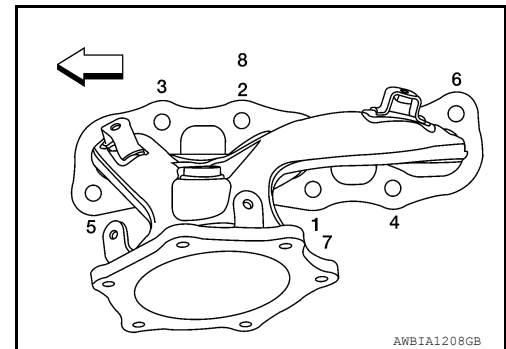

CAUTION:

- Before installing a heated oxygen sensor 2 or air fuel ratio (A/F) sensor 1, clean the exhaust manifold threads using the oxygen sensor thread cleaner tool and apply anti-seize lubricant.

Oxygen sensor thread cleaner : (J-43897-18)

Oxygen sensor thread cleaner : (J-43897-12)

- Do not over-tighten the air fuel ratio (A/F) sensor 1 or heated oxygen sensors 2. Doing so may cause damage.

Tool numbers : KV10114400 (J-38365)

: KV991J0050 (J-44626)

Removal and Installation (RH)

INFOID:000000009316299

REMOVAL

WARNING:

Revision: February 2013

EM-141

2012 Altima GCC

EXHAUST MANIFOLD AND THREE WAY CATALYST

< REMOVAL AND INSTALLATION >

[VQ35DE]

- Perform the work when the exhaust and cooling system have completely cooled down.
 - When removing the front and rear engine mount through bolts and nuts, lift the engine up slightly for safety. For engine slingers, refer to [EM-210, "Removal and Installation"](#).
1. Remove the engine and transaxle assembly. Refer to [EM-210, "Removal and Installation"](#).
 2. Remove the RH three way catalyst supports.
 3. Remove rear engine mount bracket. Refer to [EM-210, "Removal and Installation"](#).
 4. Remove heated oxygen sensor 2 (bank 1), air fuel ratio (A/F) sensor 1 (bank 1).
 - a. Remove harness connector from heated oxygen sensor 2 and air fuel ratio (A/F) sensor 1, and disconnect the harness from the bracket and middle clamp.
 - b. Remove both heated oxygen sensors 2 and air fuel ratio (A/F) sensors 1 using Tool.

Tool numbers : KV10114400 (J-38365)
: KV991J0050 (J-44626)

CAUTION:

- Be careful not to damage heated oxygen sensors 2 or air fuel ratio (A/F) sensors 1.
 - Discard any heated oxygen sensor 2 which has been dropped from a height of more than 0.5 m (19.7 in) onto a hard surface such as a concrete floor; replace with a new sensor.
5. Remove exhaust manifold heat shield (RH) and three way catalyst heat shields (RH) using power tool.
 6. Remove the three way catalyst (bank 1) by loosening the bolts first and then removing the nuts and through bolts.
 7. Loosen the exhaust manifold nuts in the reverse order as shown and remove the exhaust manifold (RH).

← : Engine front

NOTE:

Number 7 and 8 are not applicable to removal.

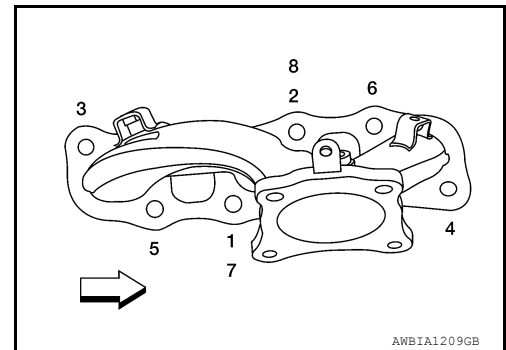

INSPECTION AFTER REMOVAL

Surface Distortion

- Use a reliable straightedge and feeler gauge to check the flatness of the exhaust manifold mating surfaces.

Limit : 0.3mm (0.012 in)

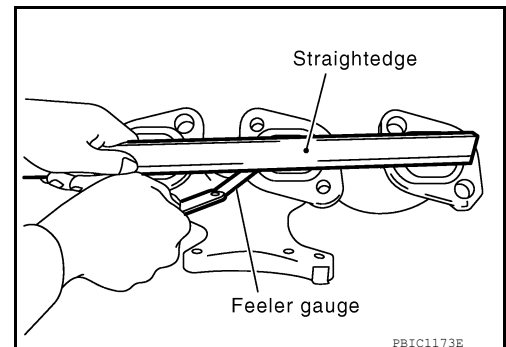

INSTALLATION

Installation is in the reverse order of removal.

CAUTION:

Do not reuse exhaust manifold gaskets.

EXHAUST MANIFOLD AND THREE WAY CATALYST

< REMOVAL AND INSTALLATION >

[VQ35DE]

- Install the exhaust manifold nuts in the order as shown (A).

← :Engine front

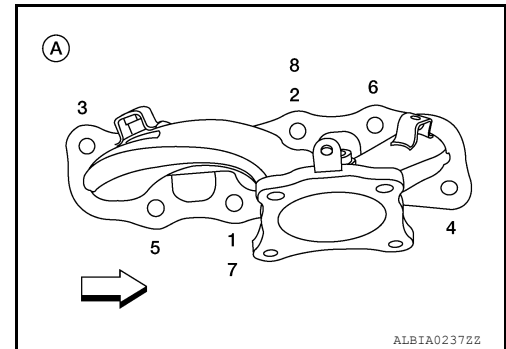

A

EM

C

D

E

F

G

H

I

J

K

L

M

N

O

P

CAUTION:

- Before installing a heated oxygen sensor 2 or air fuel ratio (A/F) sensor 1, clean the exhaust manifold threads using the oxygen sensor thread cleaner tool, and apply anti-seize lubricant.

Tool numbers : J-43897-18
: J-43897-12

- Do not over-tighten the air fuel ratio (A/F) sensor 1 or heated oxygen sensors 2. Doing so may cause damage.

Tool numbers : KV10114400 (J-38365)
: KV991J0050 (J-44626)

OIL PAN AND OIL STRAINER

< REMOVAL AND INSTALLATION >

[VQ35DE]

OIL PAN AND OIL STRAINER

Exploded View

INFOID:000000007420282

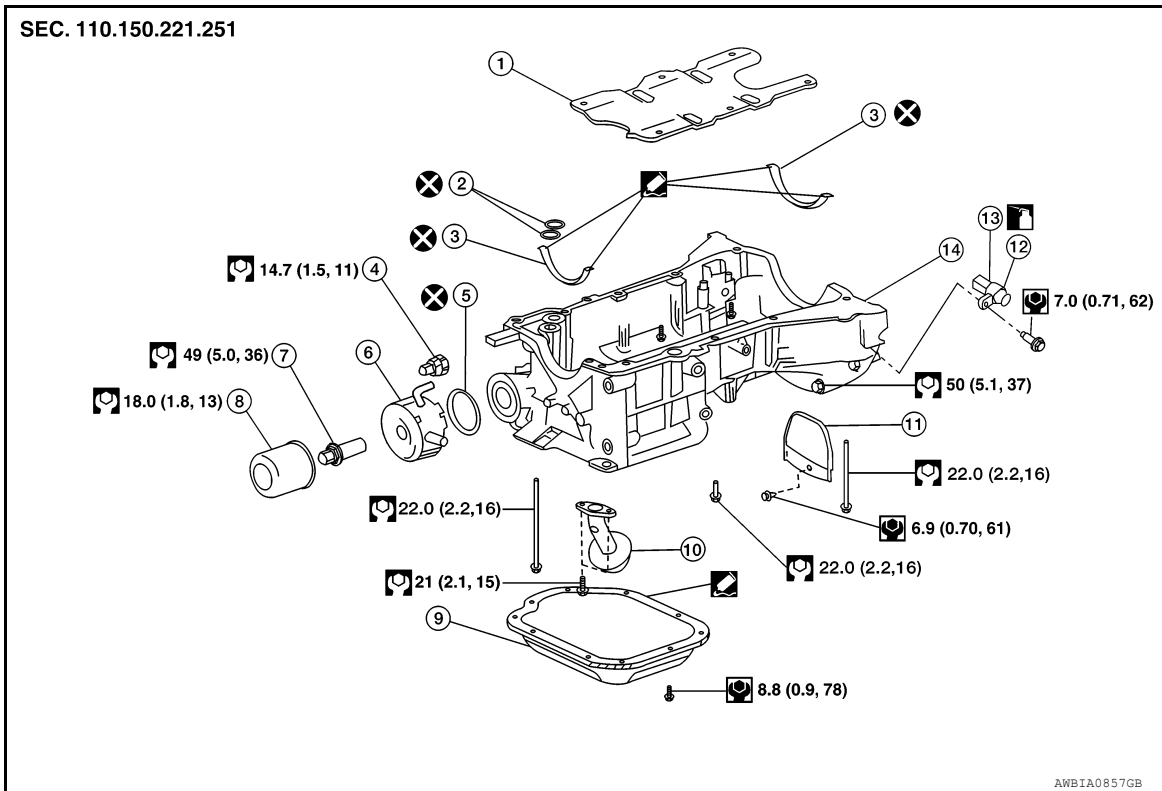

- | | | |
|--------------------------|-----------------------|--------------------------------------|
| 1. Oil pan baffle | 2. O-ring | 3. Gasket |
| 4. Oil pressure switch | 5. Oil cooler gasket | 6. Oil cooler |
| 7. Oil cooler connection | 8. Oil filter | 9. Lower oil pan |
| 10. Oil strainer | 11. Rear access plate | 12. Crankshaft position sensor (POS) |
| 13. O-ring | 14. Upper oil pan | |

Removal and Installation (Lower Oil Pan)

INFOID:000000007420283

REMOVAL

WARNING:

• You should not remove the oil pan until the exhaust system and cooling system have completely cooled off.

1. Drain the engine oil. Refer to [LU-26. "Changing Engine Oil"](#).
2. Loosen the lower oil pan bolts using power tool in order as shown.

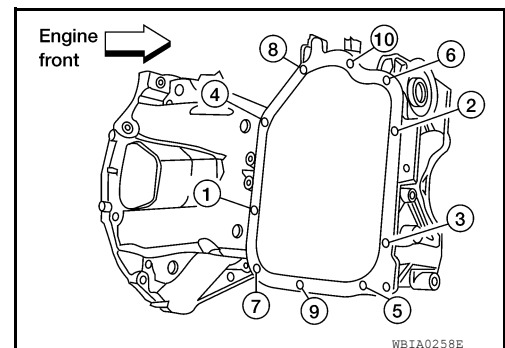

3. Remove the lower oil pan.

OIL PAN AND OIL STRAINER

< REMOVAL AND INSTALLATION >

[VQ35DE]

- a. Insert Tool between the lower oil pan and the upper oil pan.

Tool number : KV10111100 (J-37228)

CAUTION:

- Be careful not to damage the mating surface.
- Do not insert a screwdriver, this will damage the mating surfaces.

- b. Slide the Tool by tapping its side with a hammer to remove the lower oil pan from the upper oil pan.

4. If re-installing the original lower oil pan, remove the old sealant from the mating surfaces using a scraper.

- Also remove the old sealant from mating surface of the upper oil pan.
- Remove the old sealant from the bolt holes and threads.

CAUTION:

Do not scratch or damage the mating surfaces when cleaning off the old sealant.

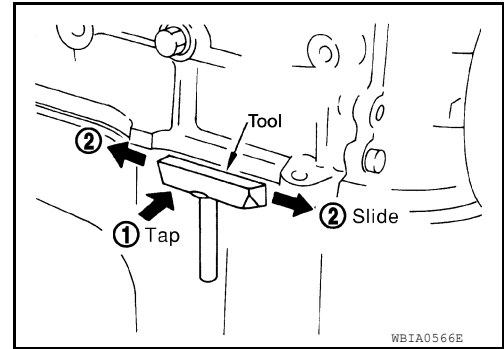

INSPECTION AFTER REMOVAL

Clean oil strainer if any object is attached.

INSTALLATION

1. Apply a continuous bead of sealant to the lower oil pan.
- Use Genuine Silicone RTV Sealant, or equivalent. Refer to [GL-15, "Recommended Chemical Products and Sealants"](#).
 - Be sure the sealant is 4.5 - 5.5 mm (0.177 - 0.217 in) wide.
 - Installation must be done within five minutes after applying sealant.

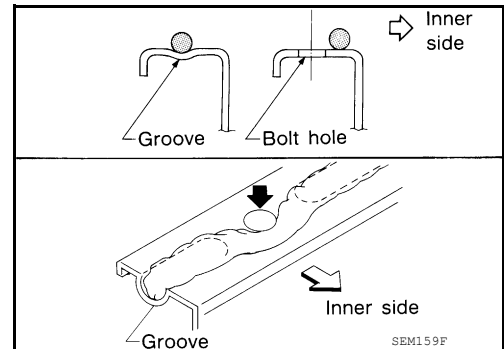

2. Install the lower oil pan. Tighten the lower oil pan bolts in order as shown.
- Wait at least 30 minutes before refilling the engine with oil.

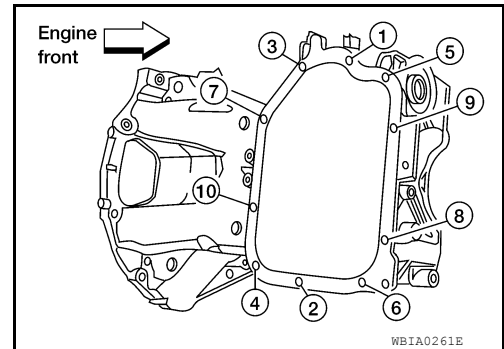

INSPECTION AFTER INSTALLATION

- Start the engine and check for leaks. Refer to [LU-25, "Inspection"](#).
- Inspect the engine oil level. Refer to [LU-25, "Inspection"](#).

Removal and Installation (Upper Oil Pan)

INFOID:000000007420284

REMOVAL

WARNING:

- Do not remove the oil pan until the exhaust system and cooling system have completely cooled off.
- When removing the front and rear engine through bolts and nuts, lift the engine up slightly for safety. For engine slingers, refer to [EM-210, "Removal and Installation"](#).

CAUTION:

When removing the upper oil pan from the engine, first remove the crankshaft position sensor (POS). Be careful not to damage sensor edges or signal plate teeth.

NOTE:

OIL PAN AND OIL STRAINER

[VQ35DE]

< REMOVAL AND INSTALLATION >

When removing components such as hoses, tubes/lines, etc., cap or plug openings to prevent fluid from spilling.

1. Remove the engine from the vehicle. Refer to [EM-210, "Removal and Installation"](#).
2. Drain the engine oil. Refer to [LU-26, "Changing Engine Oil"](#).
3. Remove the oil dipstick.
4. Remove the drive belt. Refer to [EM-123, "Removal and Installation"](#).
5. Disconnect the A/C compressor harness connector.
6. Remove the A/C compressor bolts and remove the A/C compressor. Refer to [HA-32, "Removal and Installation for Compressor - VQ35DE Models"](#).
7. Remove coolant pipe bolts.
8. Disconnect the coolant lines from the engine oil cooler.
9. Remove the oil filter and engine oil cooler from the upper oil pan.
10. Remove the oil pressure switch, and the crankshaft position sensor (POS) from the upper oil pan.
11. Remove the lower oil pan. Refer to [EM-144, "Removal and Installation \(Lower Oil Pan\)"](#).
12. Remove the upper oil pan.
 - a. Loosen the bolts in the order as shown, using power tool.

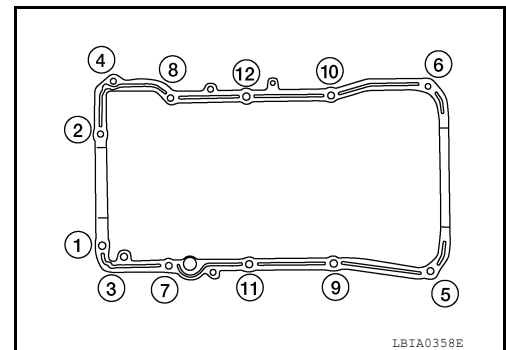

- b. Insert an appropriate size tool into the notch (1) of the upper oil pan as shown.
- c. Pry off the upper oil pan by moving the tool up and down (2) as shown.

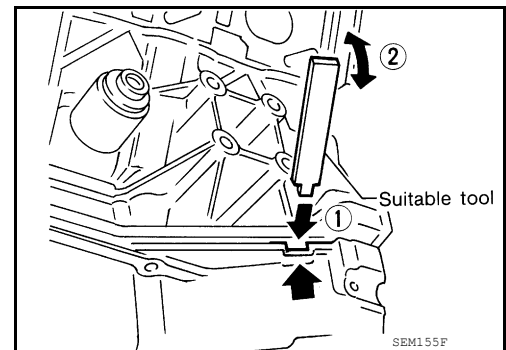

13. Remove the O-ring seals from the bottom of the cylinder block and oil pump housing. Use new O-rings for installation.

CAUTION:
Do not reuse O-rings.

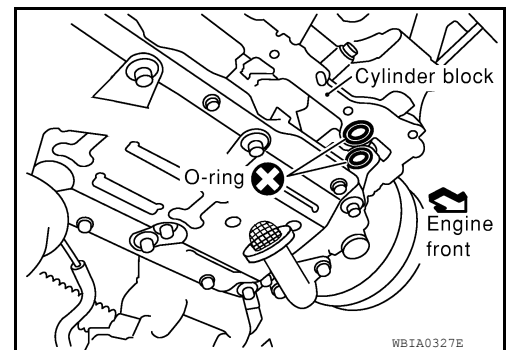

OIL PAN AND OIL STRAINER

[VQ35DE]

< REMOVAL AND INSTALLATION >

14. Remove front cover gasket and rear oil seal retainer gasket.
15. Remove the oil strainer.

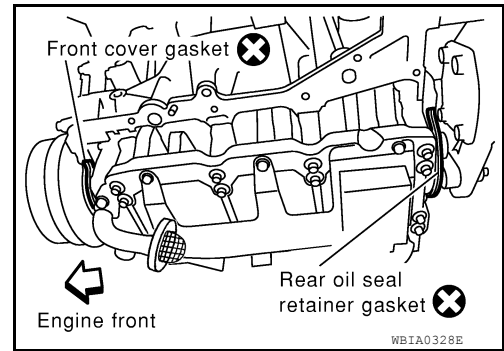

16. If re-installing the original oil pan, remove the old sealant from the mating surfaces using a scraper.
 - Also remove the old sealant from mating surface of the cylinder block.
 - Remove the old sealant from the bolt holes and threads.**CAUTION:**
Do not scratch or damage the mating surfaces when cleaning off the old sealant.

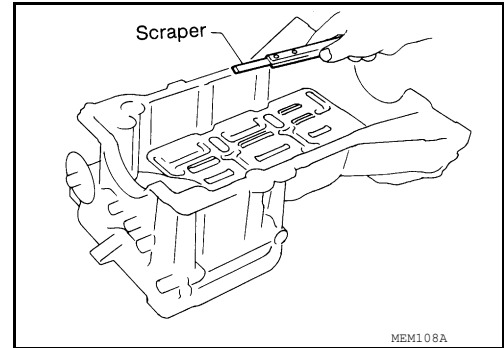

INSPECTION AFTER REMOVAL

Clean oil strainer if any object is attached.

INSTALLATION

1. Install oil strainer and tighten bolt to specified torque. Refer to [EM-144, "Exploded View"](#).
2. Apply Genuine Silicone RTV Sealant or equivalent, to the front cover gasket and the rear oil seal retainer gasket as shown. Refer to [GI-15, "Recommended Chemical Products and Sealants"](#).

Tool number : WS39930000 (—)

CAUTION:

The components must be installed within 5 minutes of the liquid gasket application. Then allow 30 minutes for the liquid gasket to set before operating the engine.

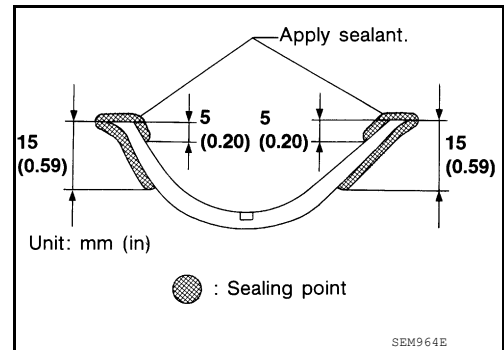

3. Install the front cover gasket and rear oil seal retainer gasket as shown.
CAUTION:
Do not reuse gaskets.

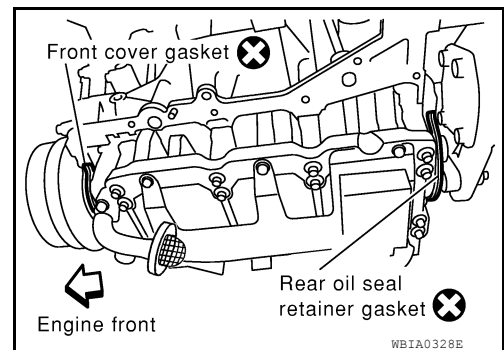

OIL PAN AND OIL STRAINER

[VQ35DE]

< REMOVAL AND INSTALLATION >

4. Apply a bead of sealant to the cylinder block mating surface of the upper oil pan to a limited portion as shown.
 - Use Genuine Silicone RTV Sealant, or equivalent. Refer to [GI-15. "Recommended Chemical Products and Sealants"](#).
 - Be sure the sealant is applied to a limited portion as shown, and the sealant is 4.0 - 5.0 mm (0.157 - 0.197 in) or 4.5 - 5.5 mm (0.177 - 0.217 in) wide.
 - Attaching should be done within 5 minutes after coating.

Tool number : WS39930000 (—)

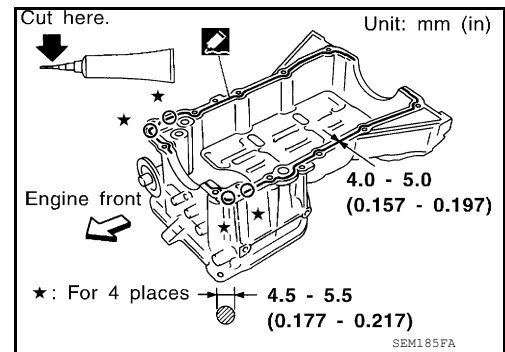

CAUTION:

The components must be installed within 5 minutes of the liquid gasket application. Then allow 30 minutes for the liquid gasket to set before operating the engine.

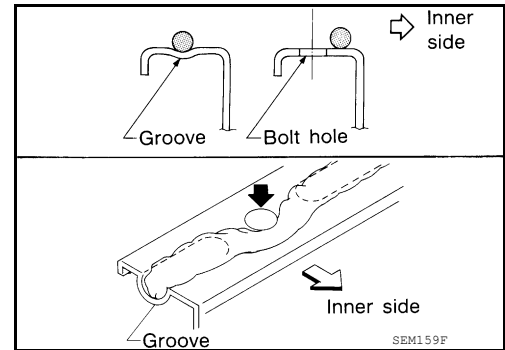

5. Install new O-rings on the cylinder block and oil pump body.

CAUTION:

Do not reuse O-rings.

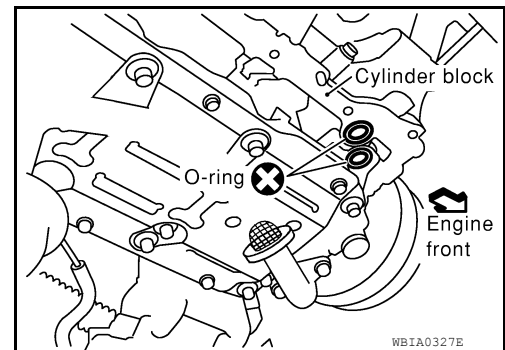

6. Install the upper oil pan.
 - Tighten upper oil pan bolts in the order as shown.
 - Wait at least 30 minutes before refilling the engine with oil.

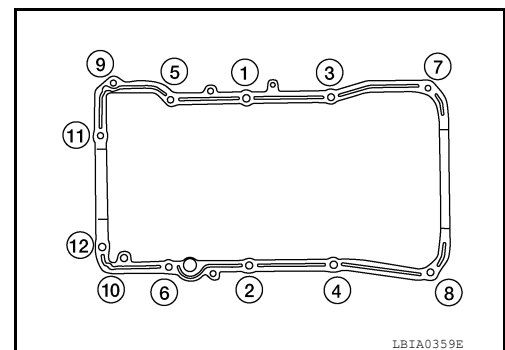

7. Install the lower oil pan. Refer to [EM-144. "Removal and Installation \(Lower Oil Pan\)"](#).

8. Installation of the remaining components is in the reverse order of removal.

INSPECTION AFTER INSTALLATION

- Before starting engine, check oil/fluid levels including engine coolant and engine oil. If less than required quantity, fill to the specified level. Refer to [MA-12. "Fluids and Lubricants"](#).
- Use procedure below to check for fuel leakage.
- Turn ignition switch ON (with engine stopped). With fuel pressure applied to fuel piping, check for fuel leakage at connection points.

OIL PAN AND OIL STRAINER

< REMOVAL AND INSTALLATION >

[VQ35DE]

- Start engine. With engine speed increased, check again for fuel leakage at connection points.
- Run engine to check for unusual noise and vibration.

A

NOTE:

If hydraulic pressure inside timing chain tensioner drops after removal and installation, slack in the guide may generate a pounding noise during and just after engine start. However, this is normal. Noise will stop after hydraulic pressure rises.

EM

- Warm up engine thoroughly to make sure there is no leakage of fuel, exhaust gas, or any oils/fluids including engine oil and engine coolant.
- Bleed air from passages in lines and hoses, such as in cooling system.
- After cooling down engine, again check oil/fluid levels including engine oil and engine coolant. Refill to specified level, if necessary.
- Summary of the inspection items:

C

D

Item		Before starting engine	Engine running	After engine stopped
Engine coolant		Level	Leakage	Level
Engine oil		Level	Leakage	Level
Transmission/ transaxle fluid	A/T and CVT Models	Leakage	Level/Leakage	Leakage
	M/T Models	Level/Leakage	Leakage	Level/Leakage
Other oils and fluids*		Level	Leakage	Level
Fuel		Leakage	Leakage	Leakage
Exhaust gas		—	Leakage	—

E

F

G

*Power steering fluid, brake fluid, etc.

H

I

J

K

L

M

N

O

P

IGNITION COIL

< REMOVAL AND INSTALLATION >

[VQ35DE]

IGNITION COIL

Exploded View

INFOID:000000007420285

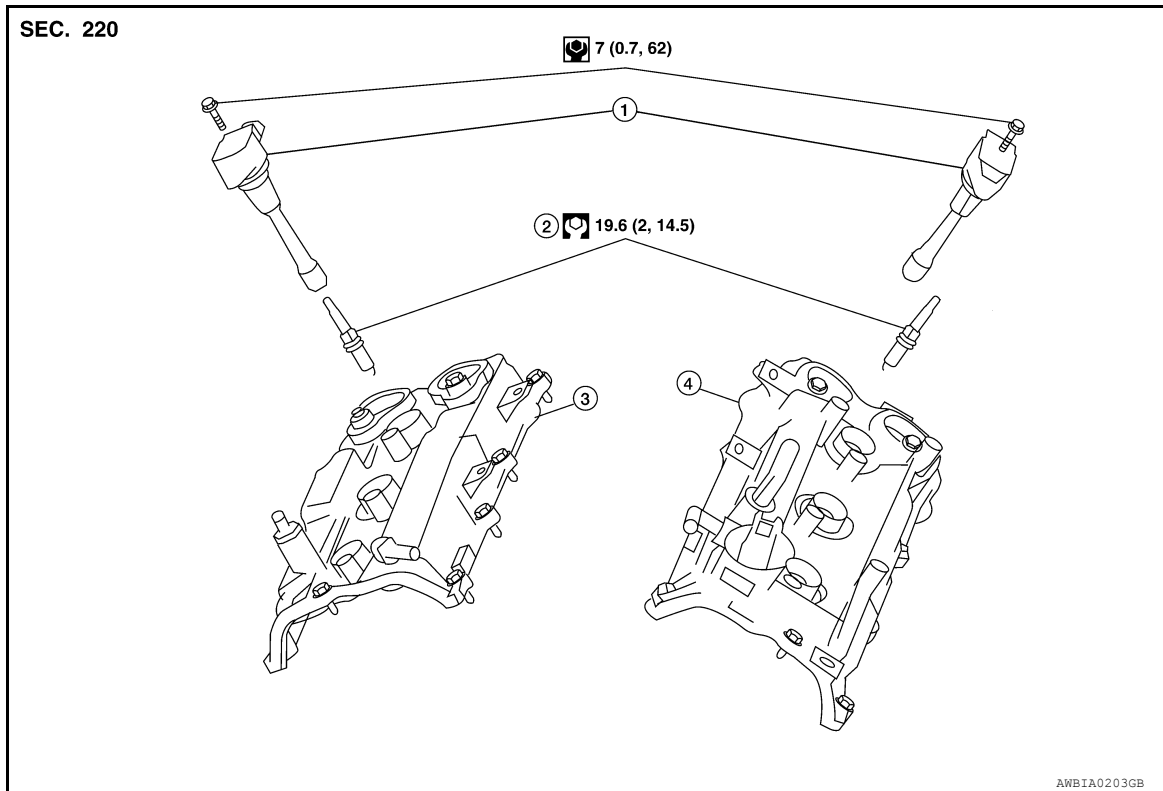

1. Ignition coil
2. Spark plug
3. Rocker cover (RH)
4. Rocker cover (LH)

Removal and Installation LH

INFOID:000000007420286

REMOVAL

1. Remove engine room cover.
2. Disconnect ignition coil connector.
3. Remove the ignition coil.

CAUTION:

Do not shock ignition coil.

INSTALLATION

Installation is in the reverse order of removal.

Removal and Installation RH

INFOID:000000007420287

REMOVAL

1. Disconnect the battery negative terminal. Refer to [PG-68, "Removal and Installation \(Battery\)"](#) (Coupe models) or [PG-140, "Removal and Installation \(Battery\)"](#) (Sedan models).
2. Remove the intake manifold collector. Refer to [EM-133, "Removal and Installation"](#).
3. Disconnect ignition coil connector.
4. Remove the ignition coil.

CAUTION:

Do not shock ignition coil.

INSTALLATION

IGNITION COIL

< REMOVAL AND INSTALLATION >

[VQ35DE]

Installation is in the reverse order of removal.

A

EM

C

D

E

F

G

H

I

J

K

L

M

N

O

P

FUEL INJECTOR AND FUEL TUBE

< REMOVAL AND INSTALLATION >

[VQ35DE]

FUEL INJECTOR AND FUEL TUBE

Removal and Installation

INFOID:000000007420288

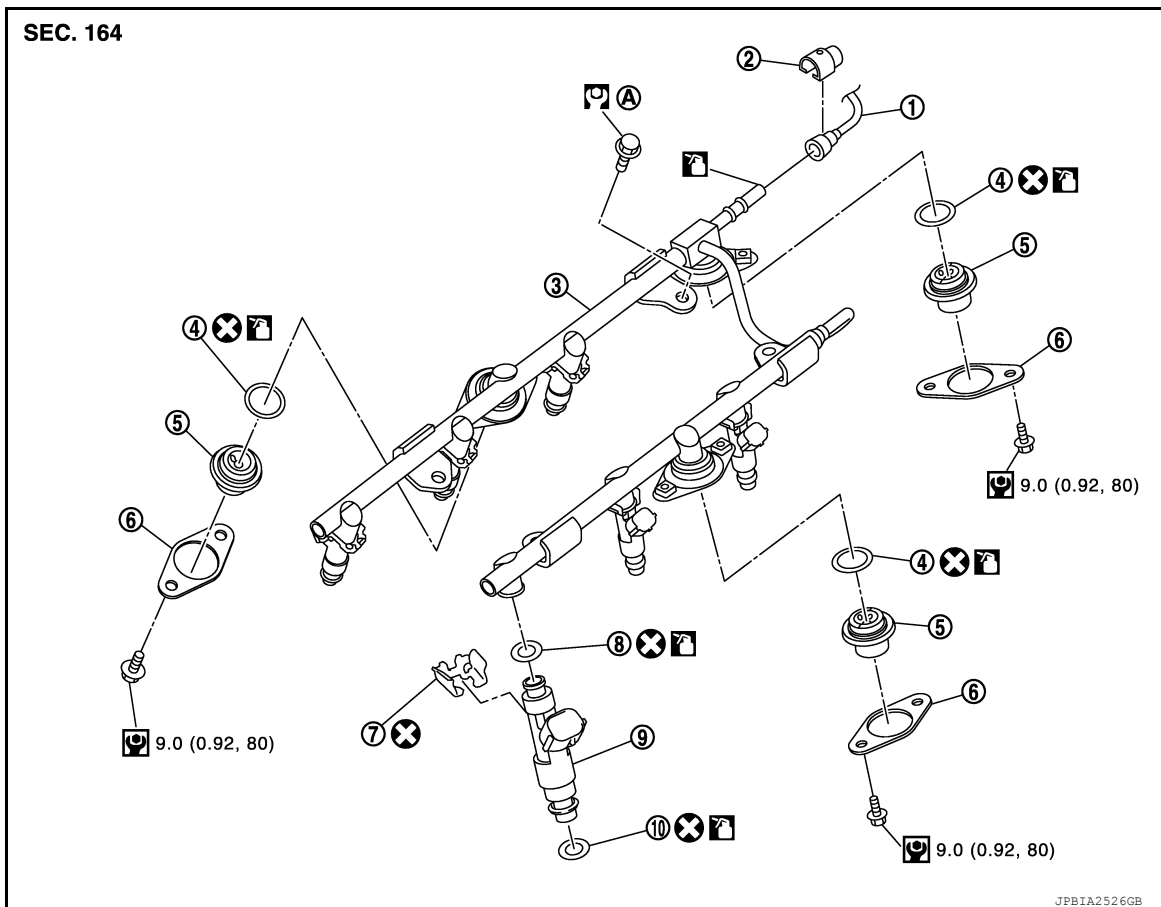

- | | | |
|--------------------|----------------------------------|--------------------|
| 1. Fuel feed hose | 2. Quick connector cap | 3. Fuel tube |
| 4. O-ring | 5. Fuel damper | 6. Fuel damper cap |
| 7. Clip | 8. O-ring (black) | 9. Fuel injector |
| 10. O-ring (green) | A. Follow installation procedure | |

CAUTION:

- Apply new engine oil when installing the parts as specified to do so.
- Do not remove or disassemble parts unless instructed as shown.

REMOVAL

WARNING:

- Put a "CAUTION: FLAMMABLE" sign in the workshop.
- Be sure to work in a well ventilated area and furnish workshop with a CO₂ fire extinguisher.
- Do not smoke while servicing fuel system. Keep open flames and sparks away from the work area.
- To avoid the danger of being scalded, do not drain engine coolant when engine is hot.

1. Remove engine room cover.
2. Release the fuel pressure. Refer to [EC-700, "Inspection"](#).
3. Disconnect the battery negative terminal. Refer to [PG-68, "Removal and Installation \(Battery\)"](#) (Coupe models) or [PG-140, "Removal and Installation \(Battery\)"](#) (Sedan models).
4. Remove front wiper arm and cowl top extension. Refer to [EXT-21, "Removal and Installation"](#) (Coupe models) or [EXT-45, "Removal and Installation"](#) (Sedan models).
5. Remove the strut tower bar. Refer to [FSU-14, "Exploded View"](#).

FUEL INJECTOR AND FUEL TUBE

[VQ35DE]

< REMOVAL AND INSTALLATION >

6. Remove the electric throttle control actuator bolts in the reverse order as shown and remove the electric throttle control actuator.

CAUTION:

- Handle carefully to avoid any shock to the electric throttle control actuator.
- Do not disassemble.

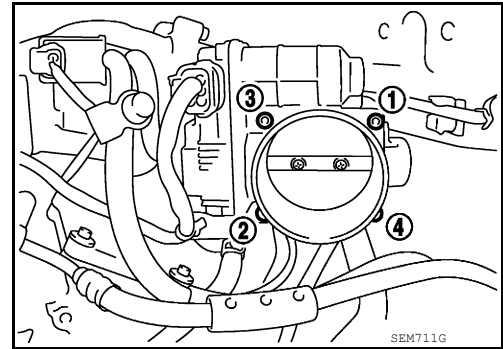

7. Remove intake manifold collector. Refer to [EM-133. "Removal and Installation"](#).
8. When separating fuel feed hose and fuel tube connection, disconnect quick connector as follows:

- a. Remove quick connector cap from quick connector.
- b. Disconnect quick connector from fuel tube as follows:

CAUTION:

Disconnect quick connector by using the quick connector release (commercial service tool: J-45488), not by picking out retainer tabs.

- i. With the sleeve side of quick connector release facing to quick connector, install the quick connector release onto fuel tube.
- ii. Insert the quick connector release (A) into quick connector (2) until sleeve (B) contacts and goes no further. Hold quick connector release on that position.

C : Insert and retain

CAUTION:

Inserting quick connector release hard will not disconnect quick connector. Hold quick connector release where it contacts and goes no further.

- iii. Draw and pull out quick connector straight from fuel tube (1).

CAUTION:

- Do not reuse O-ring.
- Pull quick connector (E) holding position (D) as shown.
- Do not pull with lateral force applied. O-ring inside quick connector may be damaged.
- Prepare container and cloth beforehand as fuel will leak out.
- Avoid fire and sparks.
- Keep parts away from heat source. Especially, be careful when welding is performed around them.
- Do not expose parts to battery electrolyte or other acids.
- Do not bend or twist connection between quick connector and fuel feed hose (with damper) during installation/removal.
- To keep clean the connecting portion and to avoid damage and foreign materials, cover them completely with plastic bags, etc. (A) or something similar.

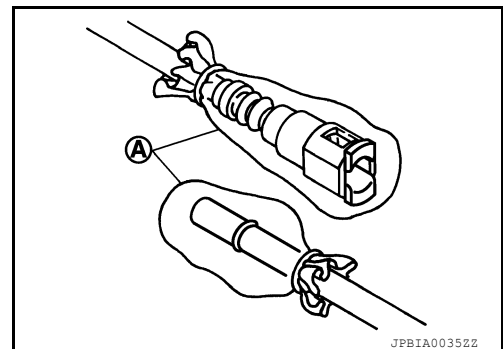
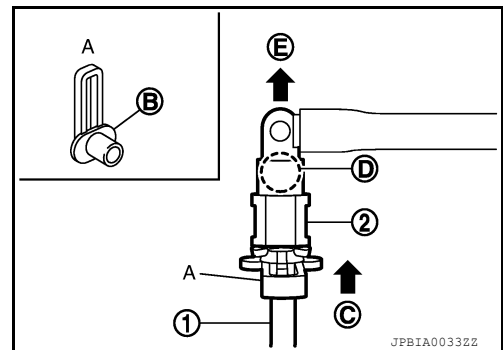

9. Disconnect harness connector from fuel injector.

FUEL INJECTOR AND FUEL TUBE

[VQ35DE]

< REMOVAL AND INSTALLATION >

10. Loosen bolts in reverse order as shown, and remove fuel tube and fuel injector assembly.

← : Engine front

CAUTION:

Do not tilt fuel tube, or remaining fuel in pipes may flow out from pipes.

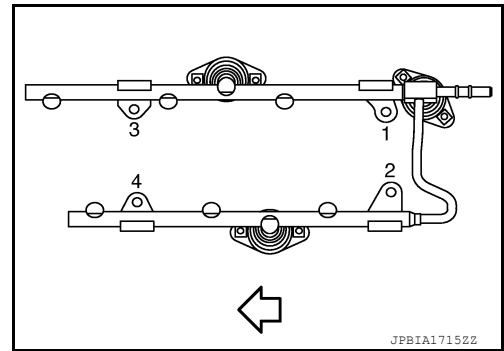

11. Remove fuel injector from fuel tube as follows:

- a. Open and remove clip (1).

- 3 : O-ring (green)
- 4 : O-ring (black)
- A : Installed condition
- B : Clip groove

- b. Remove fuel injector (2) from fuel tube (5) by pulling straight.

CAUTION:

- Do not reuse O-rings.
- Be careful with remaining fuel that may go out from fuel tube.
- Be careful not to damage injector nozzle during removal.
- Do not bump or drop fuel injector.
- Do not disassemble fuel injector.

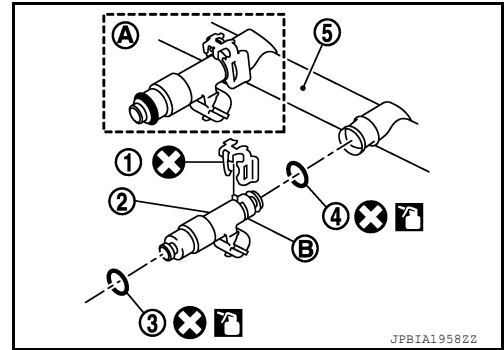

12. Remove fuel damper from fuel tube.

INSTALLATION

1. Install fuel damper as follows:

- a. Install new O-ring (2) to fuel tube (1) as shown. When handling new O-ring, be careful of the following caution:

CAUTION:

- Do not reuse O-ring.
- Handle O-ring with bare hands. Do not wear gloves.
- Lubricate O-ring with new engine oil.
- Do not clean O-ring with solvent.
- Check that O-ring and its mating part are free of foreign material.
- When installing O-ring, be careful not to scratch it with tool or fingernails. Also be careful not to twist or stretch O-ring. If O-ring was stretched while it was being attached, do not insert it quickly into fuel tube.
- Insert new O-ring straight into fuel tube. Do not twist it.

- b. Install spacer (3) to fuel damper (4).

- c. Insert fuel damper straight into fuel tube.

CAUTION:

- Insert straight, checking that the axis is lined up.
- Do not pressure-fit with excessive force.

Reference value : 130 N (13.3 kg, 29.2 lb)

- Insert fuel damper until (B) is touching (A) of fuel tube.

- d. Tighten bolts evenly in turn.

- After tightening bolts, check that there is no gap between fuel damper cap (5) and fuel tube.

2. Install new O-rings to fuel injector paying attention to the following.

CAUTION:

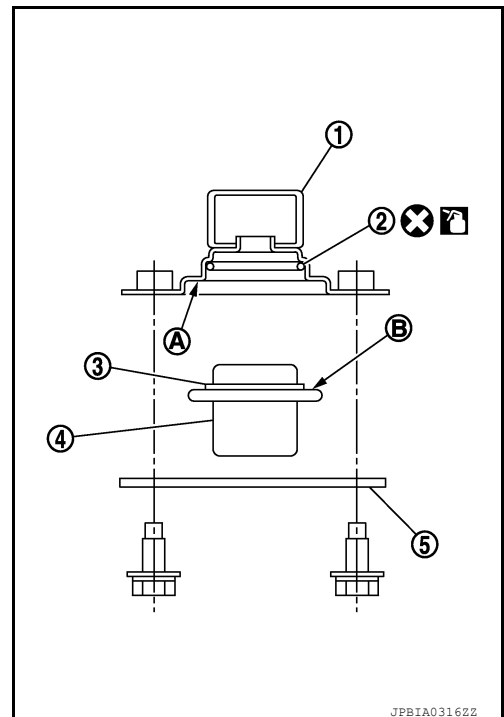

FUEL INJECTOR AND FUEL TUBE

< REMOVAL AND INSTALLATION >

[VQ35DE]

- Do not reuse O-rings.
- Upper and lower O-ring are different. Be careful not to confuse them.

Fuel tube side : Black

Nozzle side : Green

- Handle O-ring with bare hands. Do not wear gloves.
- Lubricate O-ring with new engine oil.
- Do not clean O-ring with solvent.
- Check that O-ring and its mating part are free of foreign material.
- When installing O-ring, be careful not to scratch it with tool or fingernails. Also be careful not to twist or stretch O-ring. If O-ring was stretched while it was being attached, do not insert it quickly into fuel tube.
- Insert O-ring straight into fuel injector. Do not decenter or twist it.

3. Install fuel injector to fuel tube as follows:

a. Insert clip (3) into clip groove (F) on fuel injector (5).

2 : O-ring (black)

4 : O-ring (green)

- Insert clip so that protrusion (E) of fuel injector matches cutout (C) of clip.

CAUTION:

- Do not reuse O-rings.
- Do not reuse clip. Replace it with new one.
- Be careful to keep clip from interfering with O-ring. If interference occurs, replace O-ring.

b. Insert fuel injector into fuel tube (1) with clip attached.

- Insert it while matching it to the axial center.
- Insert fuel injector so that protrusion (A) of fuel tube matches cutout (B) of clip.
- Check that fuel tube flange (G) is securely fixed in flange fixing groove (D) on clip.

c. Check that installation is complete by checking that fuel injector does not rotate or come off.

- Check that protrusions of fuel injectors and fuel tubes are aligned with cutouts of clips after installation.

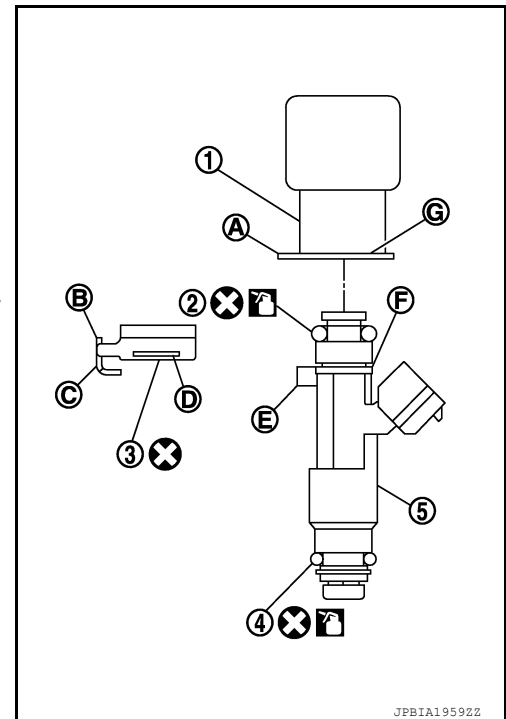

4. Install fuel tube and fuel injector assembly to intake manifold.

CAUTION:

Be careful not to let tip of injector nozzle come in contact with other parts.

- Tighten bolts in two steps in numerical order as shown.

← : Engine front

1st step : 10.1 N·m (1.0 kg-m, 7 ft-lb)

2nd step : 22.0 N·m (2.2 kg-m, 16 ft-lb)

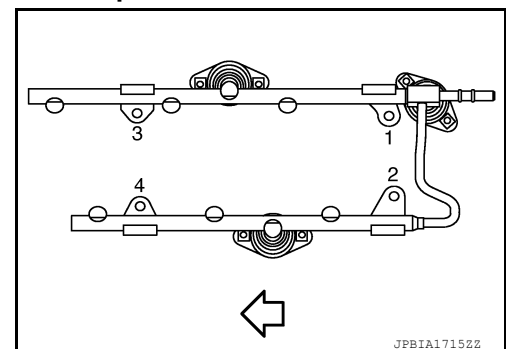

5. Connect fuel injector harness.

6. Install intake manifold collector. Refer to [EM-133, "Removal and Installation"](#).

7. Connect quick connector between fuel feed hose and fuel tube connection with the following procedure:

- a. Check no foreign substances are deposited in and around fuel tube and quick connector, and no damage on them.

FUEL INJECTOR AND FUEL TUBE

[VQ35DE]

< REMOVAL AND INSTALLATION >

- b. Thinly apply new engine oil around fuel tube from tip end to spool end.
- c. Align center to insert quick connector straightly into fuel tube.
 - Insert quick connector (1) to fuel tube until top spool (2) is completely inside quick connector, and 2nd level spool (3) exposes right below quick connector.

B : Fitted condition

⇨ : Upright insertion

CAUTION:

- Do not reuse O-ring.
- Hold (A) position as shown when inserting fuel tube into quick connector.
- Carefully align center to avoid inclined insertion to prevent damage to O-ring inside quick connector.
- Insert until you hear a “click” sound and actually feel the engagement.
- To avoid misidentification of engagement with a similar sound, be sure to perform the next step.

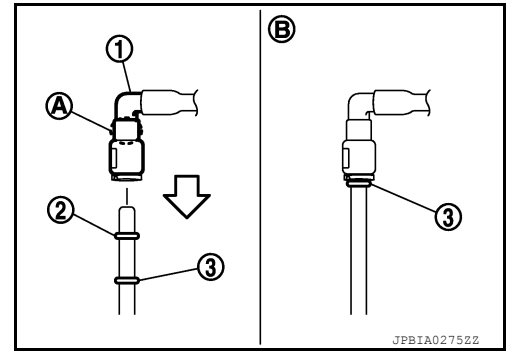

- d. Pull quick connector by hand holding position. Check it is completely engaged (connected) so that it does not come out from fuel tube.
- e. Install quick connector cap (3) to quick connector.

1 : Fuel feed hose

2 : Fuel tube

B : Upper view

- Install quick connector cap with arrow (A) on surface facing in direction of quick connector (fuel feed hose side).

CAUTION:

If quick connector cap cannot be installed smoothly, quick connector may have not been installed correctly. Check connection again.

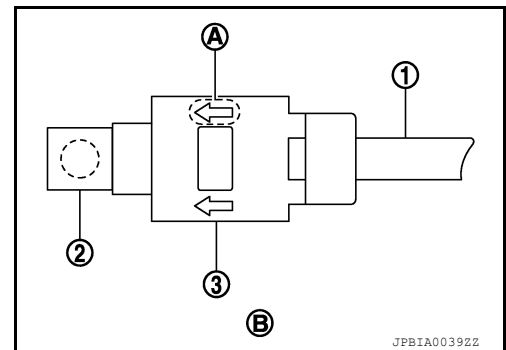

- f. Secure fuel feed hose to clamp of quick connector cap.
8. Installation of the remaining components is in the reverse order of removal.

INSPECTION AFTER INSTALLATION

Make sure there are no fuel leaks.

1. Apply pressure to fuel lines by turning ignition switch ON (with engine stopped). Then check for fuel leaks at connections.
2. Start the engine and rev it up and check for fuel leaks at connections.

CAUTION:

Do not touch engine immediately after stopping as engine is extremely hot.

NOTE:

Use mirrors for checking on connections out of the direct line of sight.

- Perform procedures for “Throttle Valve Closed Position Learning” after finishing repairs. Refer to [EC-335, “THROTTLE VALVE CLOSED POSITION LEARNING : Special Repair Requirement”](#).
- If electric throttle control actuator is replaced, perform procedures for “Idle Air Volume Learning” after finishing repairs. Refer to [EC-335, “IDLE AIR VOLUME LEARNING : Special Repair Requirement”](#).

ROCKER COVER

< REMOVAL AND INSTALLATION >

[VQ35DE]

ROCKER COVER

Exploded View

INFOID:000000007420289

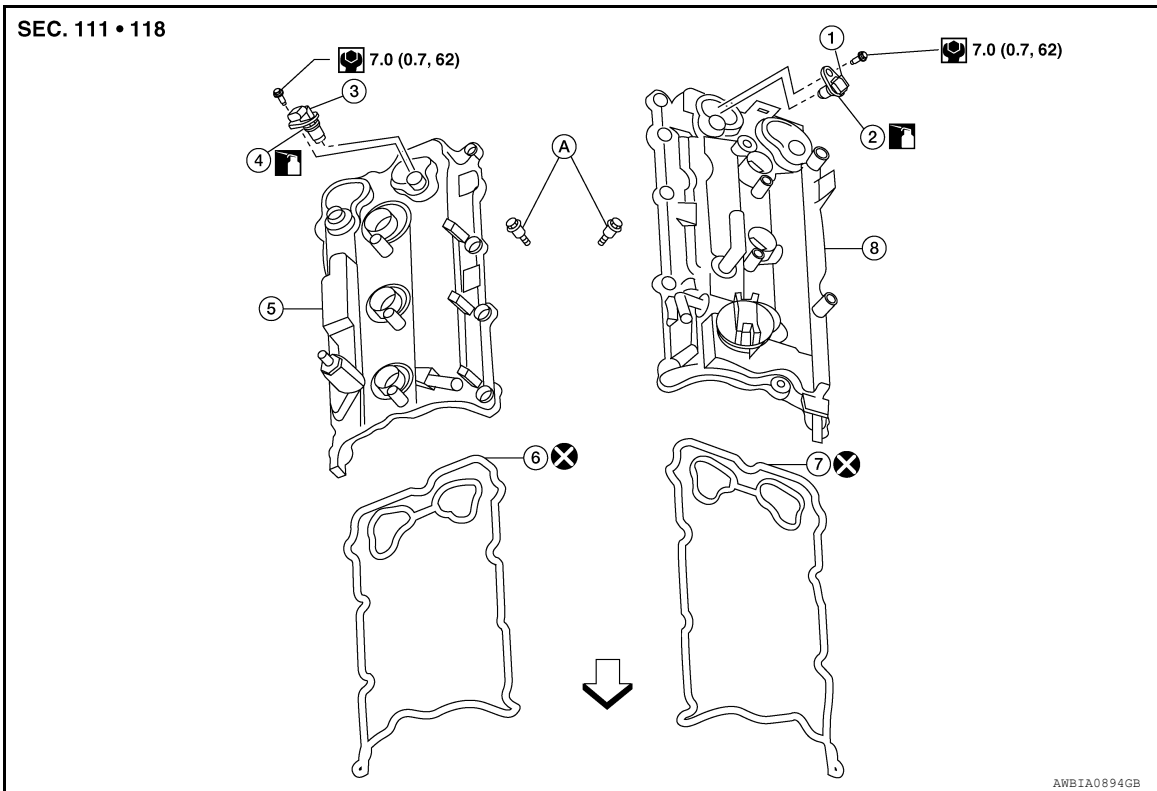

- | | | |
|----------------------------------|----------------------|----------------------------------|
| 1. Camshaft position sensor (LH) | 2. O-ring | 3. Camshaft position sensor (RH) |
| 4. O-ring | 5. Rocker cover (RH) | 6. Rocker cover gasket (RH) |
| 7. Rocker cover gasket (LH) | 8. Rocker cover (LH) | A. Follow installation procedure |

← Front

Removal and Installation LH

INFOID:000000007420290

REMOVAL

1. Remove oil filler cap.
2. Remove front air duct. Refer to [EM-132, "Removal and Installation"](#).
3. Remove blow by hose from rocker cover.
4. Remove camshaft position sensor.

CAUTION:

- Handle carefully to avoid dropping and shocks.
- Do not disassemble.
- Do not allow metal powder to adhere to magnetic part at sensor tip (A).
- Do not place sensors in a location where they are exposed to magnetism.

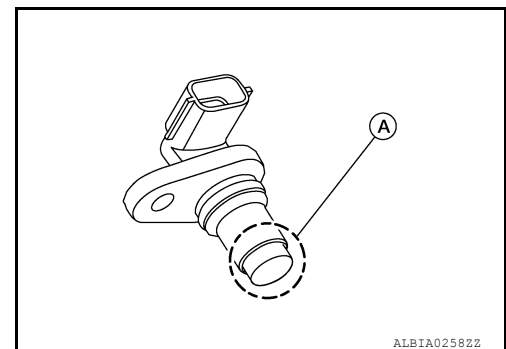

5. Disconnect the ignition coil connectors.
6. Remove the ignition coils. Refer to [EM-150, "Removal and Installation LH"](#).

CAUTION:

ROCKER COVER

< REMOVAL AND INSTALLATION >

[VQ35DE]

Do not shock ignition coils.

7. Remove LH rocker cover bolts from cylinder head as shown.

← : Engine front

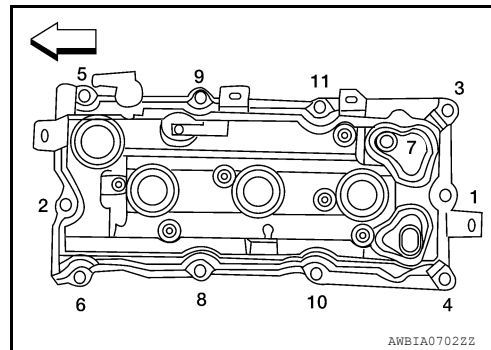

INSTALLATION

Installation is in the reverse order of removal.

- Apply sealant to the areas on the front corners using Tool.
- Use Genuine Silicone RTV Sealant or equivalent. Refer to [GI-15, "Recommended Chemical Products and Sealants"](#).

Tool number : WS39930000 (—)

CAUTION:

The components must be installed within 5 minutes of the liquid gasket application. Then allow 30 minutes for the liquid gasket to set before operating the engine.

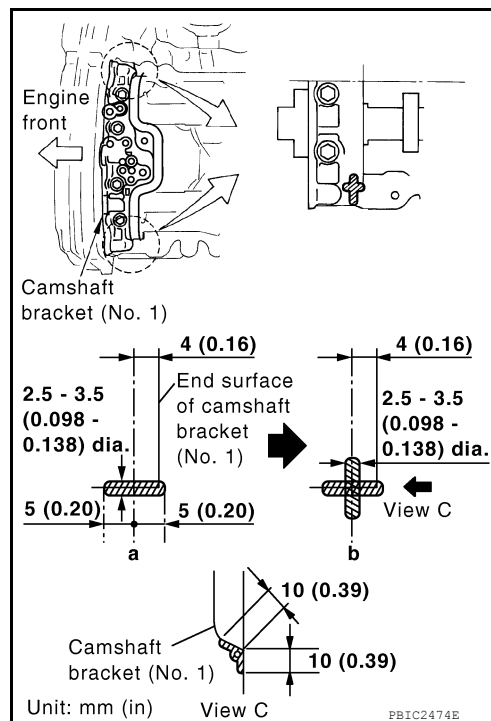

- Tighten the rocker cover bolts in two steps in the order as shown.

← : Engine front

Rocker cover bolts

Step 1 : 1.96 N·m (0.20 kg·m, 17 in-lb)

Step 2 : 8.33 N·m (0.85 kg·m, 74 in-lb)

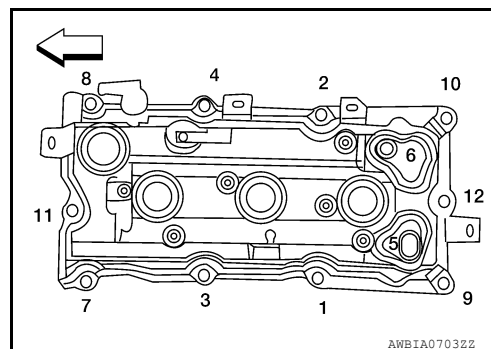

Removal and Installation RH

INFOID:000000007420291

REMOVAL

1. Remove the intake manifold collector. Refer to [EM-133, "Removal and Installation"](#).
2. Remove ignition coils. Refer to [EM-150, "Removal and Installation RH"](#).

CAUTION:

Do not shock ignition coils.

ROCKER COVER

[VQ35DE]

< REMOVAL AND INSTALLATION >

3. Remove camshaft position sensor.

CAUTION:

- Handle carefully to avoid dropping and shocks.
- Do not disassemble.
- Do not allow metal powder to adhere to magnetic part at sensor tip (A).
- Do not place sensors in a location where they are exposed to magnetism.

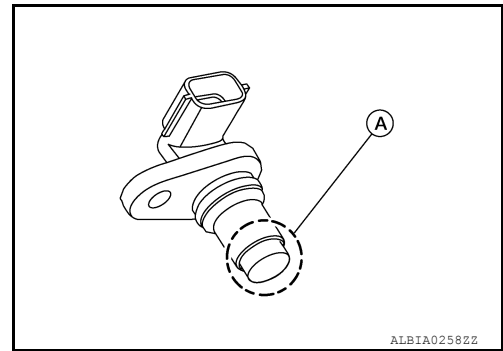

4. Remove RH rocker cover bolts from cylinder head as shown.

← : Engine front

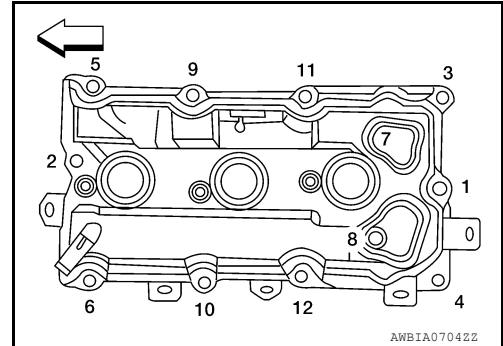

INSTALLATION

Installation is in the reverse order of removal.

- Apply sealant to the areas on the front corners using Tool.
- Use Genuine Silicone RTV Sealant or equivalent. Refer to [GI-15. "Recommended Chemical Products and Sealants"](#).

Tool number : WS39930000 (—)

CAUTION:

The components must be installed within 5 minutes of the liquid gasket application. Then allow 30 minutes for the liquid gasket to set before operating the engine.

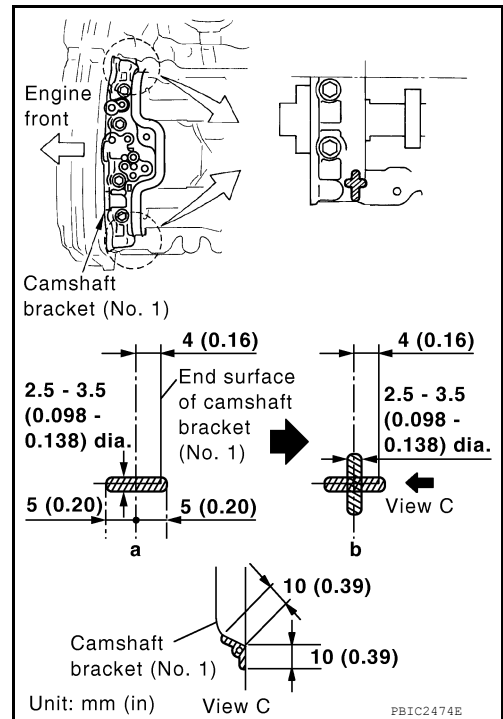

- Tighten the rocker cover bolts in two steps in the order as shown.

ROCKER COVER

< REMOVAL AND INSTALLATION >

[VQ35DE]

← : Engine front

Rocker cover bolts

Step 1 : 1.96 N·m (0.20 kg-m, 17 in-lb)

Step 2 : 8.33 N·m (0.85 kg-m, 74 in-lb)

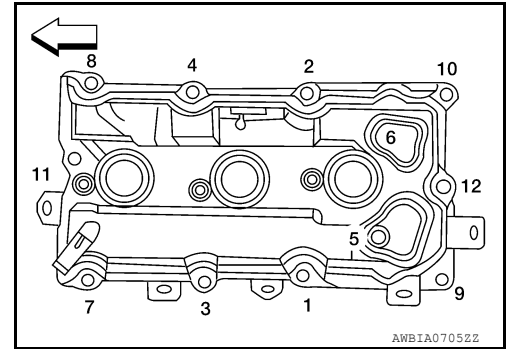

INTAKE VALVE TIMING CONTROL

< REMOVAL AND INSTALLATION >

[VQ35DE]

INTAKE VALVE TIMING CONTROL

Exploded View

INFOID:000000007697743

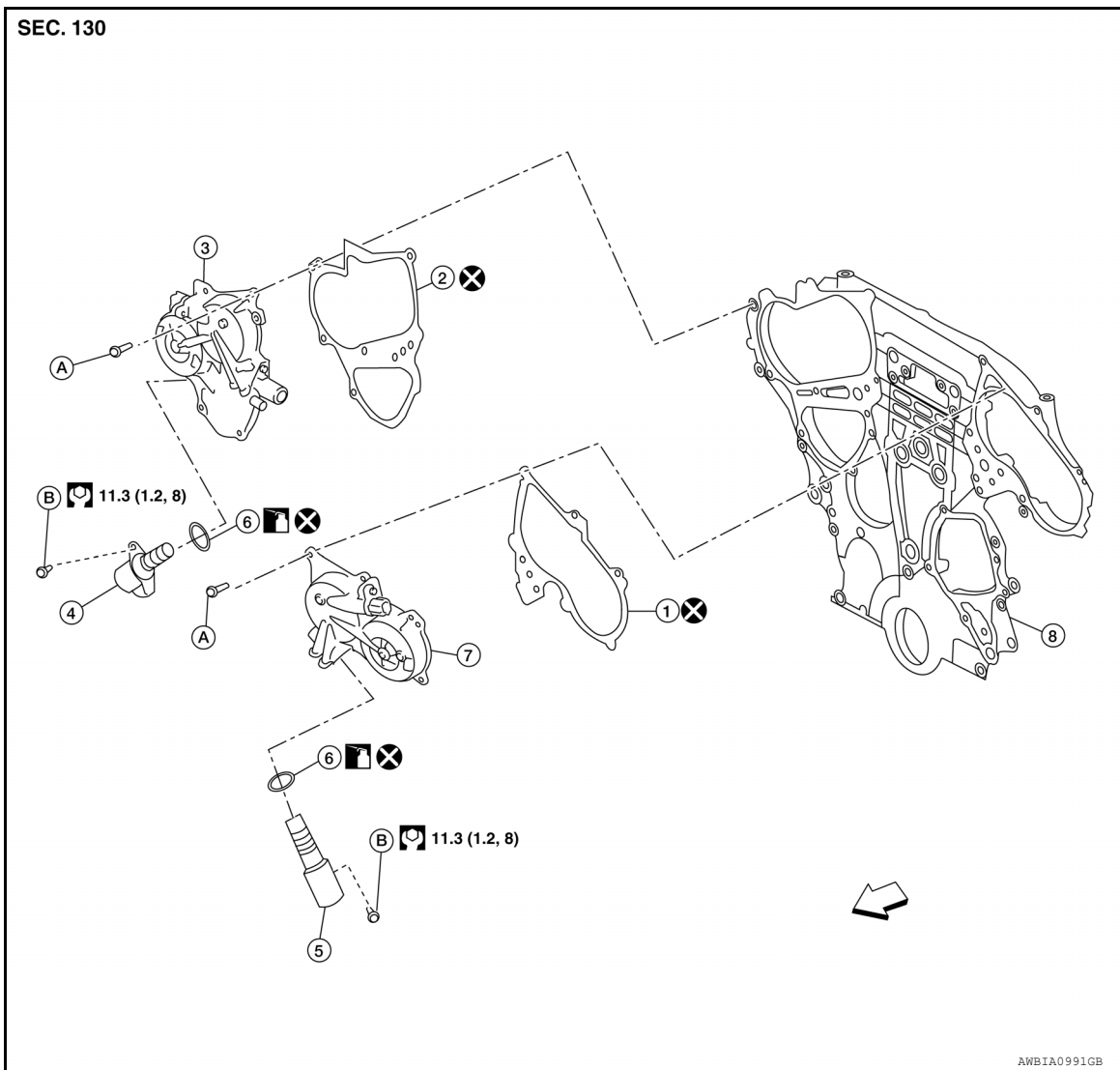

- | | | |
|--------------------------|----------------------------|----------------------------------|
| 1. Gasket LH | 2. Gasket RH | 3. IVT Cover RH (bank 1) |
| 4. IVT Valve RH | 5. IVT Valve LH | 6. O-ring |
| 7. IVT Cover LH (bank 2) | 8. Front timing chain case | A. Follow installation procedure |
| B. IVT bolt | ↶ Engine front | |

Intake Valve Timing Control Solenoid Valve (LH) (bank 2)

INFOID:000000007420292

REMOVAL

1. Remove hood ledge cover.
2. Remove coolant reservoir and set aside.
3. Disconnect intake valve timing control solenoid valve connector.
4. Remove intake valve timing control solenoid valve cover. Refer to [EM-171, "Component"](#).
5. Remove intake valve timing control solenoid valve and O-ring from intake valve timing control solenoid valve cover.

CAUTION:
Do not reuse O-ring.

INTAKE VALVE TIMING CONTROL

< REMOVAL AND INSTALLATION >

[VQ35DE]

INSTALLATION

Installation is in the reverse order of removal.

CAUTION:

- Do not reuse O-ring.
- Replace the O-ring for the intake valve timing control solenoid valve with a new one, then lubricate O-ring with engine oil before installing.

Intake valve timing control solenoid valve bolt : 11.3 N·m (1.2 kg-m, 8 ft-lb)

Intake Valve Timing Control Solenoid Valve (RH) (bank 1)

INFOID:000000007420293

REMOVAL

1. Remove hood ledge cover.
2. Remove coolant reservoir and set aside.
3. Remove power steering reservoir and set aside.
4. Support engine using suitable tool.
5. Remove upper engine mount and bracket. Refer to [EM-210, "Removal and Installation"](#).
6. Remove intake valve timing control solenoid valve cover bolt behind solenoid valve. Refer to [EM-171, "Component"](#).
7. Disconnect intake valve timing control solenoid valve connector.
8. Remove intake valve timing control solenoid valve and O-ring from Intake valve timing control solenoid valve cover.

CAUTION:

Do not reuse O-ring.

INSTALLATION

Installation is in the reverse order of removal.

CAUTION:

- Do not reuse O-ring.
- Replace the O-ring for the intake valve timing control solenoid valve with a new one, then lubricate O-ring with engine oil before installing.

Intake valve timing control solenoid valve bolt : 11.3 N·m (1.2 kg-m, 8 ft-lb)

FRONT TIMING CHAIN CASE

< REMOVAL AND INSTALLATION >

[VQ35DE]

FRONT TIMING CHAIN CASE

Removal and Installation

INFOID:000000007420294

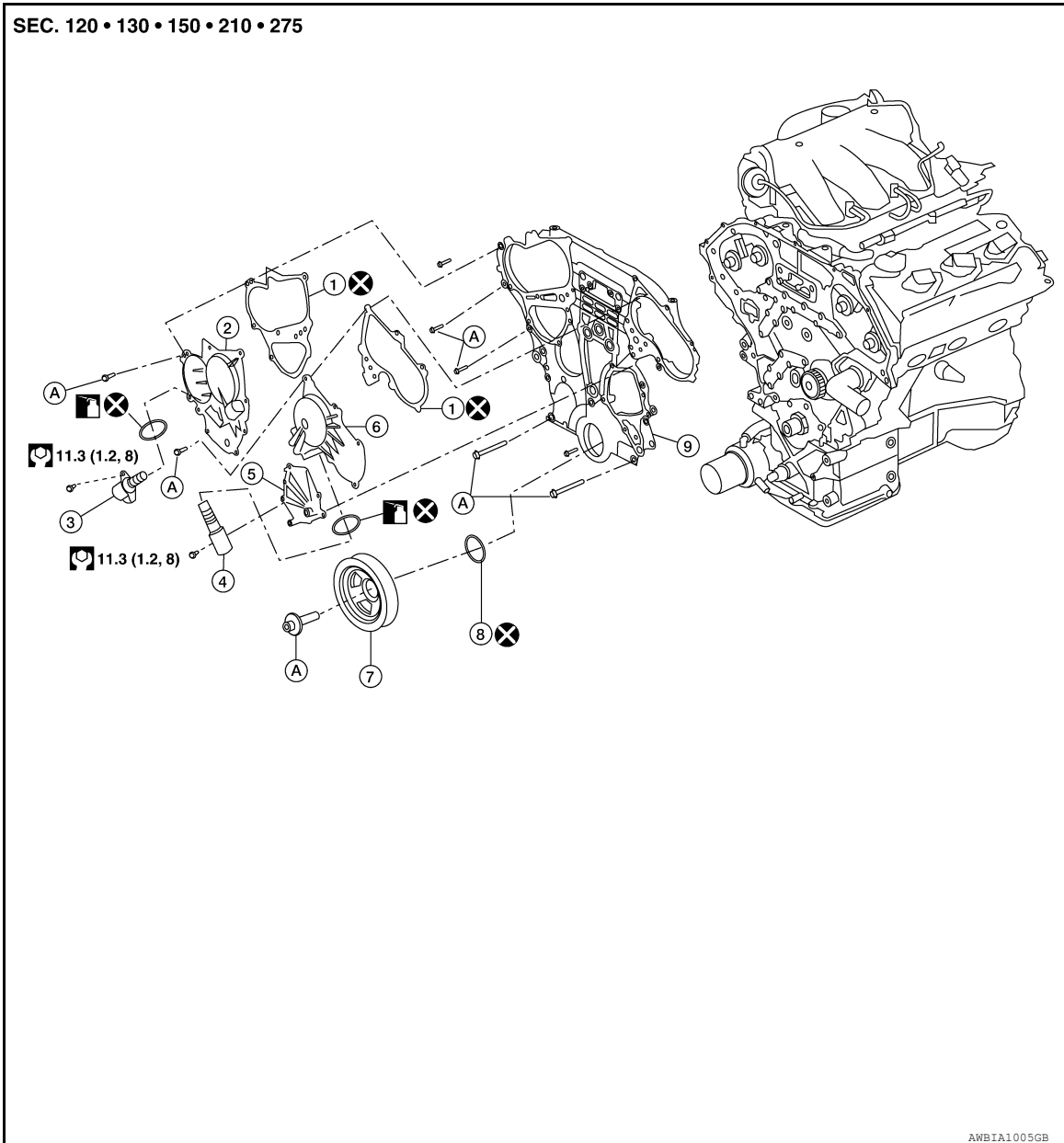

- | | | |
|----------------------------------|--------------------------|-----------------------------|
| 1. Gasket | 2. IVT cover RH (bank 1) | 3. IVT valve RH with O-ring |
| 4. IVT valve LH with O-ring | 5. Water pump cover | 6. IVT cover LH (bank 2) |
| 7. Crankshaft pulley | 8. Front oil seal | 9. Front timing chain case |
| A. Follow installation procedure | | |

NOTE:

- When rear timing chain case must be removed, remove the engine from the vehicle. Then remove front timing chain case, timing chain related parts, and rear timing chain case in this order, and install in reverse order of removal. Refer to [EM-180, "Removal and Installation"](#).
- Refer to [EM-171, "Component"](#) for component parts location.
- When removing components such as hoses, tubes/lines, etc., cap or plug openings to prevent fluid from spilling.

REMOVAL

FRONT TIMING CHAIN CASE

[VQ35DE]

< REMOVAL AND INSTALLATION >

1. Disconnect the battery negative terminal. Refer to [PG-68, "Removal and Installation \(Battery\)"](#) (Coupe) [PG-140, "Removal and Installation \(Battery\)"](#) (Sedan).
2. Remove engine undercover. Refer to [EXT-16, "Removal and Installation - Coupe"](#). (Coupe) [EXT-40, "Removal and Installation"](#) (Sedan).
3. Drain the engine coolant from the radiator. Refer to [MA-23, "ENGINE COOLANT : Changing Engine Coolant"](#).
4. Drain the engine oil. Refer to [MA-26, "ENGINE OIL : Changing Engine Oil"](#).
5. Drain the power steering fluid. Refer to [MA-39, "POWER STEERING FLUID AND LINES : Draining"](#).
6. Remove engine room cover.
7. Remove front air duct. Refer to [EM-132, "Removal and Installation"](#).
8. Remove battery tray. Refer to [PG-69, "Removal and Installation \(Battery Tray\)"](#) (Coupe) [PG-141, "Removal and Installation \(Battery Tray\)"](#) (Sedan).
9. Remove the hood ledge covers (RH and LH).
10. Remove cowl top and cowl top extension. Refer to [EXT-21, "Removal and Installation"](#) (Coupe) [EXT-45, "Removal and Installation"](#) (Sedan).
11. Remove upper radiator hose.
12. Disconnect engine coolant reservoir hose from the radiator and remove engine coolant reservoir.
13. Remove cooling fan assembly. Refer to [CO-41, "Removal and Installation"](#).
14. Disconnect lower radiator hose from engine.
15. Disconnect the power steering fluid reservoir tank hose from the power steering pump and fluid cooler and remove the power steering fluid reservoir tank. Refer to [ST-20, "VQ35DE : Exploded View"](#).
16. Remove the front RH wheel and tire. Refer to [MA-33, "WHEELS : Adjustment"](#).
17. Remove the fender protector side cover (RH). Refer to [EXT-22, "Removal and Installation"](#) (Coupe), [EXT-46, "Removal and Installation"](#) (Sedan).
18. Remove the drive belt. Refer to [EM-123, "Removal and Installation"](#).
19. Remove the access plate and lock the ring gear using Tool.

Tool number : — (J-50288)

CAUTION:

Do not damage the ring gear teeth, or the signal plate teeth behind the ring gear, when installing Tool.

20. Remove the crankshaft pulley as follows:
 - a. Loosen crankshaft pulley and locate bolt seating surface at 10 mm (0.39 in) from its original position.
 - b. Position a pulley puller at recess hole of crankshaft pulley to remove crankshaft pulley.

CAUTION:

Do not use a puller claw on crankshaft pulley periphery.

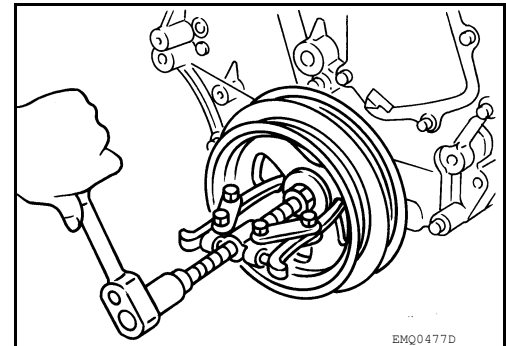

21. Remove the power steering pump. Refer to [ST-20, "VQ35DE : Removal and Installation"](#).
22. Remove the upper oil pan. Refer to [EM-145, "Removal and Installation \(Upper Oil Pan\)"](#) and [EM-145, "Removal and Installation \(Upper Oil Pan\)"](#).
23. Remove the generator. Refer to [CHG-26, "Removal and Installation"](#).
24. Disconnect the A/C tubes from the A/C compressor and position aside.
25. Remove the A/C compressor bolts and remove the A/C compressor. Refer to [HA-32, "Removal and Installation for Compressor - VQ35DE Models"](#).
26. Remove the generator bracket. Refer to [CHG-26, "Removal and Installation"](#).

FRONT TIMING CHAIN CASE

[VQ35DE]

< REMOVAL AND INSTALLATION >

27. Support the engine with suitable jack and remove the RH engine insulator, mount and bracket. Refer to [EM-210, "Removal and Installation"](#).
28. Remove the rocker covers, if necessary. Refer to [EM-157, "Removal and Installation LH"](#) and [EM-158, "Removal and Installation RH"](#).

NOTE:

Necessary only when removing timing chains.

29. If removing the timing chains, obtain compression TDC of No. 1 cylinder as follows:
 - a. Rotate crankshaft pulley clockwise to align timing mark (grooved line without color) with timing indicator.

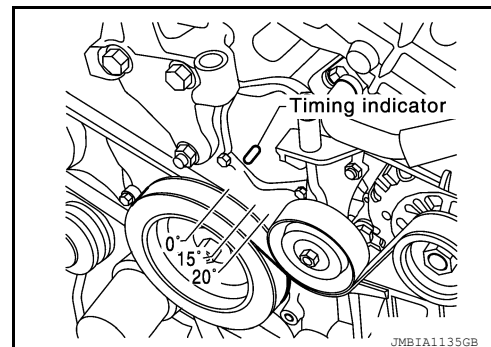

- b. Check that intake and exhaust camshaft lobes on No. 1 cylinder (right bank of engine) are located as shown.
 - If not, turn the crankshaft one revolution (360°) and align as shown.

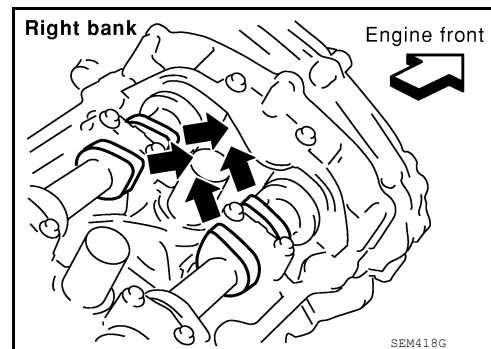

30. Remove engine oil cooler tube bolts and bracket.
31. Disconnect the oil pressure switch harness connector.
32. Disconnect valve timing control harness connector.
33. Remove the Bank 1 (RH) (A) and Bank 2 (LH) (B) IVT covers.
 - Loosen the IVT cover bolts in the reverse order as shown.

CAUTION:

The shaft in the IVT cover is inserted into the center hole of the intake camshaft sprocket. Remove the IVT cover by pulling straight out until the IVT cover disengages from the camshaft sprocket.

- A: Bank 1 (Conventional RH bank)
- B: Bank 2 (Conventional LH bank)
- C: Dowel pin hole

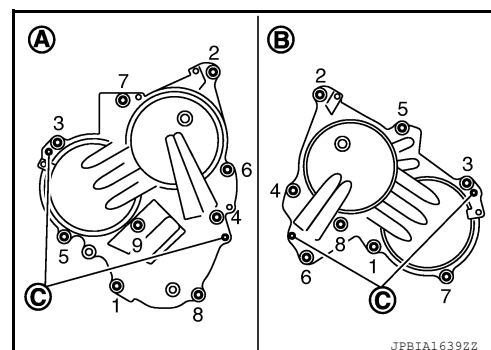

34. Remove the A/C idler pulley and bracket and the drive belt auto-tensioner.
35. If necessary, remove the idler pulley and water pump cover.
36. Remove the front timing chain case.
 - a. Loosen the front timing chain case bolts in the order as shown.

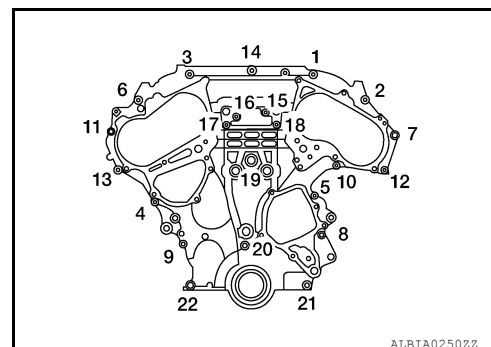

FRONT TIMING CHAIN CASE

< REMOVAL AND INSTALLATION >

[VQ35DE]

- b. Insert the appropriate size tool into the notch (A) at the top of the front timing chain case as shown.
- c. Pry off the case by moving the suitable tool (B) as shown.

CAUTION:

- Do not use a screwdriver or similar tool.
- After removal, handle carefully so it does not bend, or warp under a load.

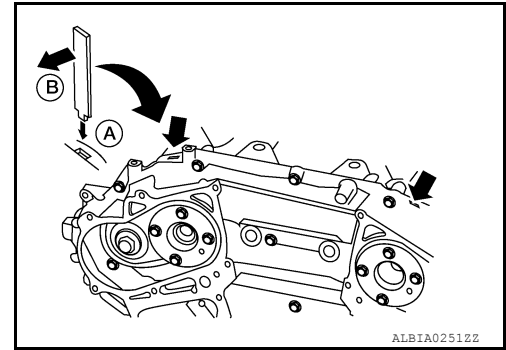

37. Remove O-rings (1) from rear timing chain case.

- A: Bank 1
- B: Bank 2

CAUTION:

- Do not reuse O-rings.

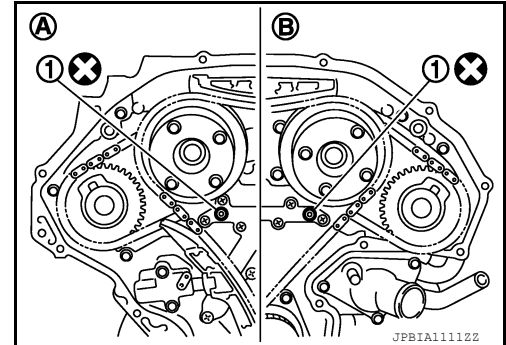

38. Remove the front oil seal from the front timing chain case using a suitable tool.

CAUTION:

- Do not damage the front cover.

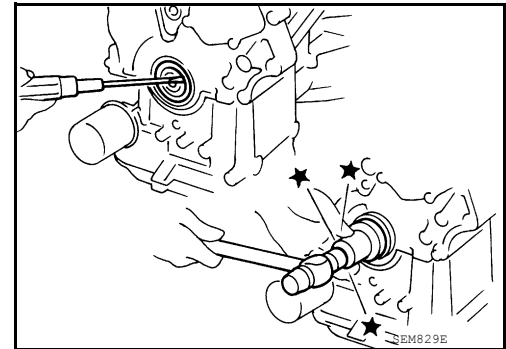

39. Remove all old Silicone RTV Sealant from all the bolt holes and bolts.

CAUTION:

- Do not damage the threads or mating surfaces.

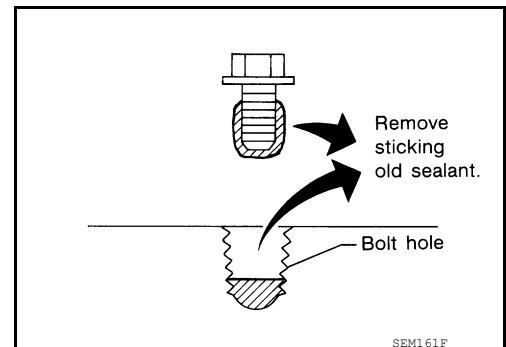

40. Use a scraper to remove all of the old Silicone RTV Sealant from the front timing chain case and opposite mating surfaces.

CAUTION:

- Do not damage the mating surfaces.

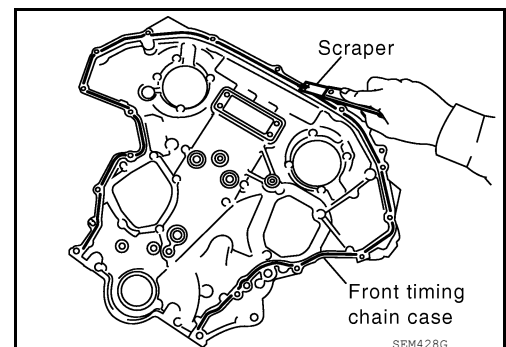

FRONT TIMING CHAIN CASE

< REMOVAL AND INSTALLATION >

[VQ35DE]

INSTALLATION

1. Install dowel pins (right and left) into front timing chain case up to a point close to taper in order to shorten protrusion length.

NOTE:

Be sure to place the dowel pins in original hole locations in the front timing chain case.

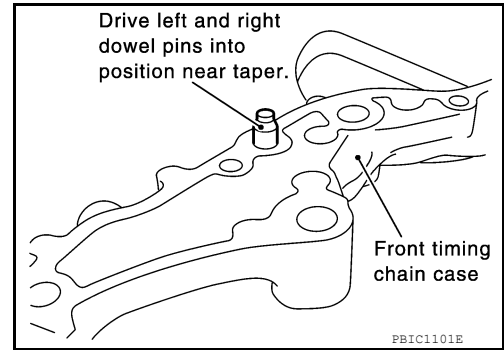

2. Install the new front oil seal on the front timing chain case. Apply new engine oil to the oil seal edges.

NOTE:

Install it so that each seal lip is oriented as shown.

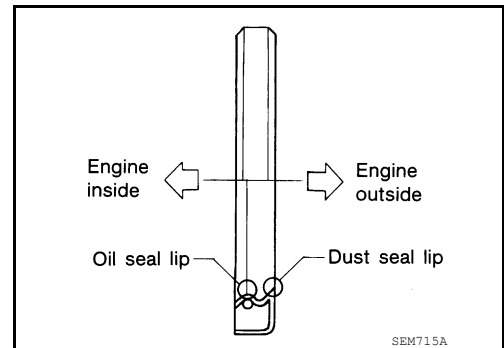

- a. Install the new front oil seal so that it becomes flush with the face with front timing chain case using suitable drift.

CAUTION:

Press fit straight and avoid causing burrs or tilting the oil seal.

NOTE:

Make sure the garter spring is in position and seal lip is not inverted.

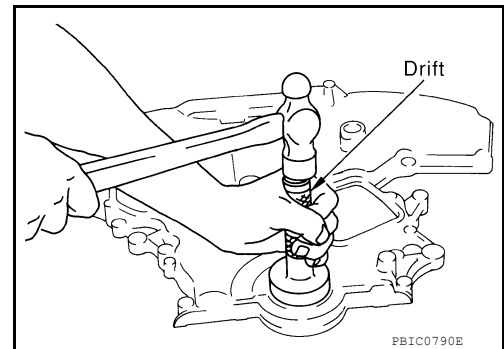

3. Install new O-rings (1) on rear timing chain case.

- A: Bank 1
- B: Bank 2

CAUTION:

Do not reuse O-rings.

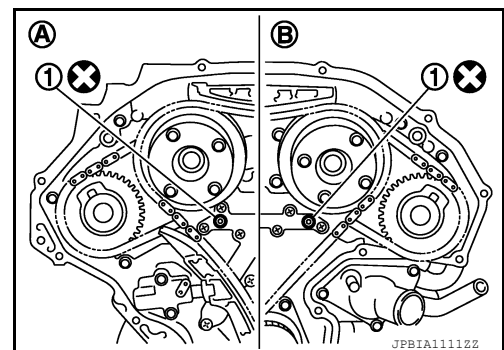

FRONT TIMING CHAIN CASE

[VQ35DE]

< REMOVAL AND INSTALLATION >

4. Apply Silicone RTV Sealant to front timing chain case as shown.
 - Use Genuine Silicone RTV Sealant, or equivalent. Refer to [GI-15. "Recommended Chemical Products and Sealants"](#).
 - Before installation, wipe off the protruding sealant.
 - C: 2.6 - 3.6 mm (0.102 - 0.142 in) dia.

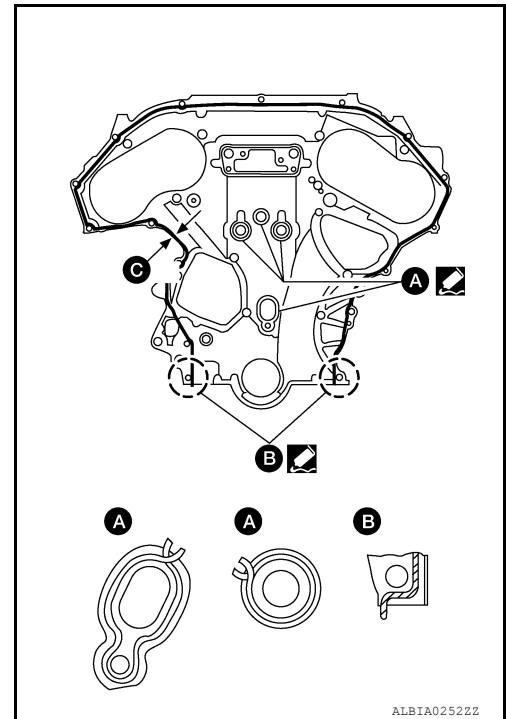

5. Install dowel pin on the rear timing chain case into dowel pin hole in front timing chain case.
6. Loosely install the front timing chain case bolts.

Bolt position	Bolt diameter
1, 2	: 8 mm (0.31 in)
3 - 22	: 6 mm (0.24 in)

7. Tighten the front timing chain case bolts in the order as shown.
 - Retighten the front timing chain case bolts in the order as shown.

Bolt position	Tightening specification
1, 2	: 28.5 N·m (2.9 kg-m, 21 ft-lb)
3 - 22	: 12.8 N·m (1.3 kg-m, 9 ft-lb)

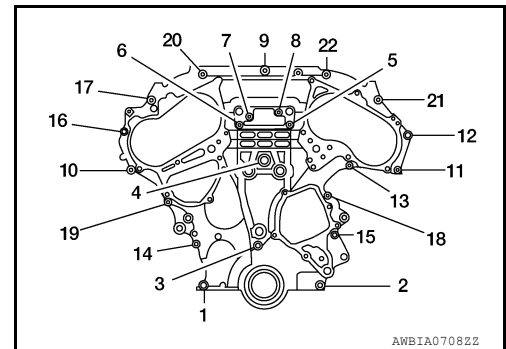

8. Install upper oil pan bolts as shown. Refer to [EM-145. "Removal and Installation \(Upper Oil Pan\)"](#) and [EM-145. "Removal and Installation \(Upper Oil Pan\)"](#).

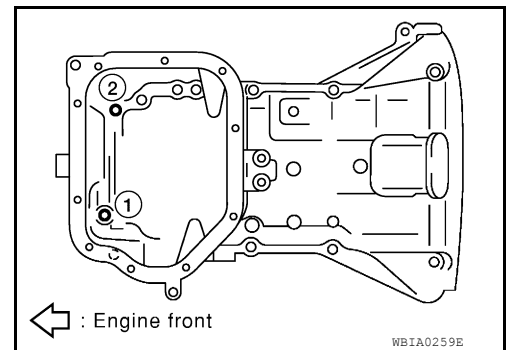

9. Install lower oil pan. Refer to [EM-144. "Removal and Installation \(Lower Oil Pan\)"](#).
10. Install intake valve timing control covers as follows:
 - a. Install new seal rings in shaft grooves.
 - b. Being careful not to move seal rings from the installation grooves, align dowel pins on front timing chain case with the holes to install valve timing control covers.

FRONT TIMING CHAIN CASE

< REMOVAL AND INSTALLATION >

[VQ35DE]

c. Tighten bolts in numerical order as shown.

IVT cover bolts 11.3 N·m (1.2 kg-m, 8 ft-lb)

- A: Bank 1
- B: Bank 2
- C: Dowel pin hole

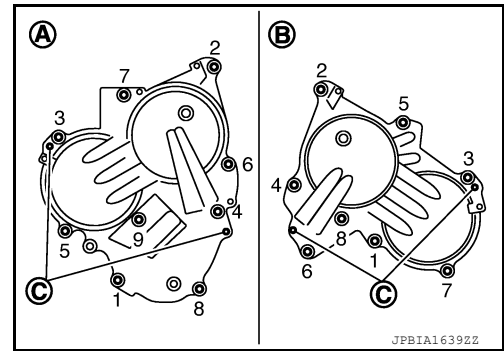

11. Apply liquid gasket and install the water pump cover, if removed.
• Use Genuine Silicone RTV Sealant or equivalent. Refer to [GI-15, "Recommended Chemical Products and Sealants"](#).

12. Install crankshaft pulley and tighten the bolt in two steps.
• Lubricate thread and seat surface of the bolt with new engine oil.
• Apply a paint mark for the second step of angle tightening.

Step 1 : 44 N·m (4.5 kg-m, 32 ft-lb)

Step 2 : 84° - 90° degrees clockwise

Tool Number : KV10112100 (BT-8653-A)

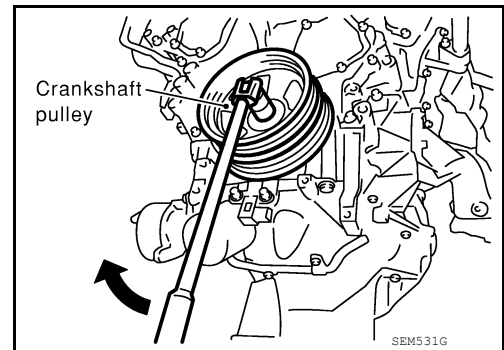

13. Remove Tool and install access plate.

Tool number : — (J-50288)

CAUTION:

Do not damage the drive plate teeth, or the signal plate teeth behind the drive plate, when removing the Tool.

14. Rotate crankshaft pulley in normal direction (clockwise when viewed from front) to confirm it turns smoothly.

15. Installation of the remaining components is in reverse order of removal.

INSPECTION AFTER INSTALLATION

- Before starting engine, check oil/fluid levels including engine coolant and engine oil. If less than required quantity, fill to the specified level. Refer to [MA-12, "Fluids and Lubricants"](#).
- Use procedure below to check for fuel leakage.
- Turn ignition switch ON (with engine stopped). With fuel pressure applied to fuel piping, check for fuel leakage at connection points.
- Start engine. With engine speed increased, check again for fuel leakage at connection points.
- Run engine to check for unusual noise and vibration.

NOTE:

- If hydraulic pressure inside timing chain tensioner drops after removal and installation, slack in the guide may generate a pounding noise during and just after engine start. However, this is normal. Noise will stop after hydraulic pressure rises.
- Warm up engine thoroughly to make sure there is no leakage of fuel, exhaust gas, or any oils/fluids including engine oil and engine coolant.
- Bleed air from passages in lines and hoses, such as in cooling system.
- After cooling down engine, again check oil/fluid levels including engine oil and engine coolant. Refill to specified level, if necessary.
- Summary of the inspection items:

FRONT TIMING CHAIN CASE

< REMOVAL AND INSTALLATION >

[VQ35DE]

Item		Before starting engine	Engine running	After engine stopped
Engine coolant		Level	Leakage	Level
Engine oil		Level	Leakage	Level
Transmission/ transaxle fluid	A/T and CVT Models	Leakage	Level/Leakage	Leakage
	M/T Models	Level/Leakage	Leakage	Level/Leakage
Other oils and fluids*		Level	Leakage	Level
Fuel		Leakage	Leakage	Leakage
Exhaust gas		—	Leakage	—

*Power steering fluid, brake fluid, etc.

TIMING CHAIN

< REMOVAL AND INSTALLATION >

[VQ35DE]

TIMING CHAIN

Component

SEC. 120 • 130 • 150 • 210 • 275

INFOID:000000007420295

A

EM

C

D

E

F

G

H

I

J

K

L

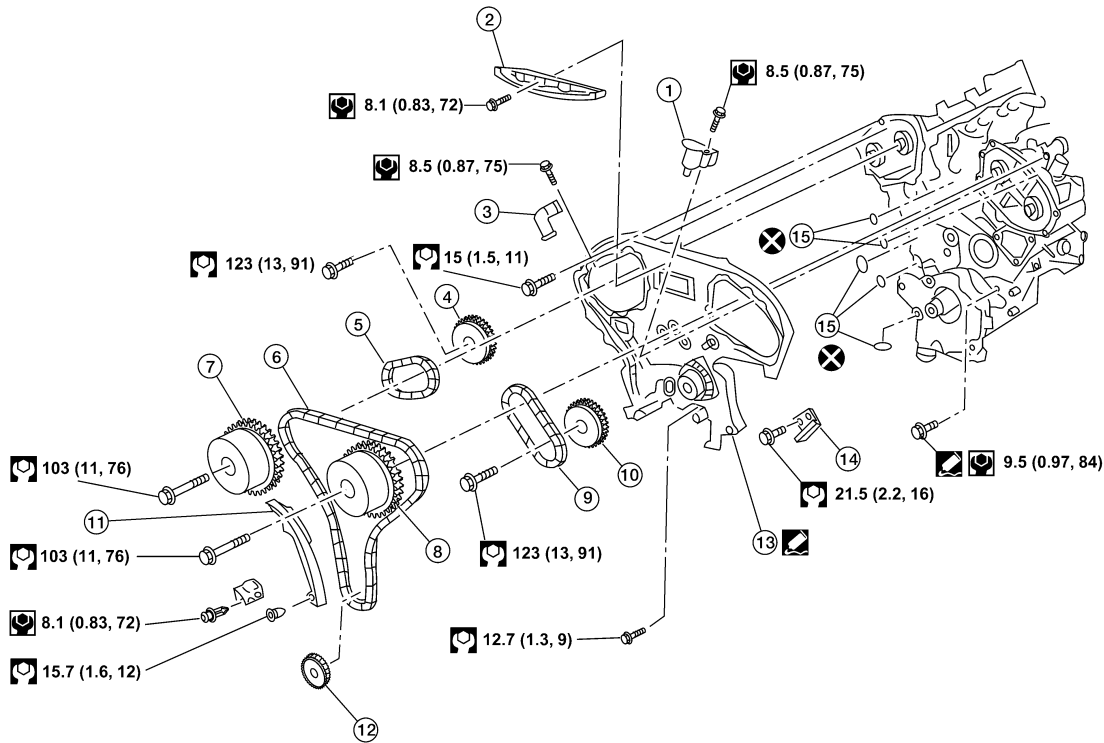

AWBIA0578GB

- | | | |
|-----------------------------|-----------------------------|-----------------------------|
| 1. Timing chain tensioner | 2. Internal chain guide | 3. Timing chain tensioner |
| 4. Camshaft sprocket (EXH) | 5. Timing chain (secondary) | 6. Timing chain (primary) |
| 7. Camshaft sprocket (INT) | 8. Camshaft sprocket (INT) | 9. Timing chain (secondary) |
| 10. Camshaft sprocket (EXH) | 11. Slack guide | 12. Crankshaft sprocket |
| 13. Rear timing chain case | 14. Tension guide | 15. O-ring |

- Refer to [EM-113. "Precaution for Liquid Gasket"](#).
- Before installation, wipe off any protruding sealant.

CAUTION:

- After removing timing chain, do not turn the crankshaft and camshaft separately, or the valves will strike the pistons.
- When installing camshafts, chain tensioners, oil seals, or other sliding parts, lubricate contacting surfaces with new engine oil.
- Apply new engine oil to bolt threads and seat surfaces when installing camshaft sprockets, camshaft brackets, and crankshaft pulley.

Removal

INFOID:000000007420296

1. Remove front timing chain case. Refer to [EM-163. "Removal and Installation"](#).

M

N

O

P

TIMING CHAIN

[VQ35DE]

< REMOVAL AND INSTALLATION >

2. Remove the intake manifold collector. Refer to [EM-133, "Removal and Installation"](#).
3. Remove the six ignition coils. Refer to [EM-150, "Removal and Installation LH"](#) (LH) and [EM-150, "Removal and Installation RH"](#) (RH).
4. Remove the rocker covers. Loosen the bolts in the numerical order as shown.

⇐ : Front

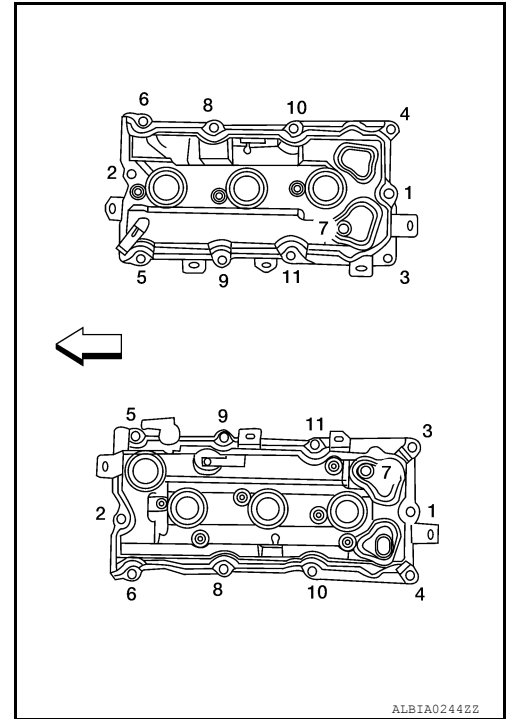

5. Place paint marks on the timing chain and sprockets to indicate the correct position of the components for installation.
6. Remove the timing chain tensioner (primary).
 - a. Pull lever down and release plunger stopper tab. Plunger stopper tab can be pushed up to release (coaxial structure with lever).

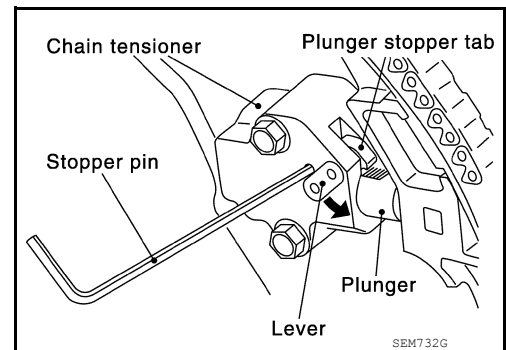

- b. Insert stopper pin into tensioner body hole to hold lever, and keep the tab released. An Allen wrench [1.2 mm (0.047 in)] is used for a stopper pin as an example.
- c. Insert plunger into tensioner body by pressing the slack side chain guide.
- d. Keep the slack side chain guide pressed and hold it by pushing the stopper pin through the lever hole and body hole.
- e. Remove the bolts and remove the timing chain tensioner.

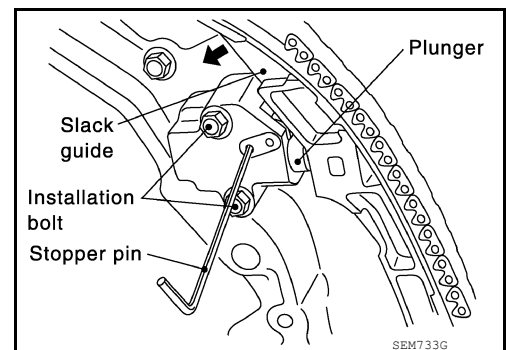

7. Remove the internal chain guide, and slack guide.
8. Remove primary timing chain and crankshaft sprocket.

CAUTION:

After removing timing chain, do not turn the crankshaft and camshaft separately, or the valves will strike the pistons.

TIMING CHAIN

< REMOVAL AND INSTALLATION >

[VQ35DE]

9. Attach a suitable stopper pin to the right and left camshaft chain tensioners (for secondary timing chains).

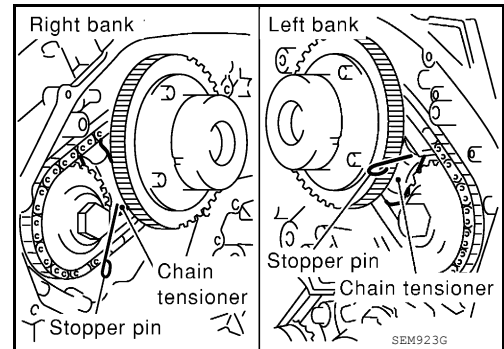

10. Remove the intake and exhaust camshaft sprocket bolts.
- Apply paint to the timing chain and camshaft sprockets for alignment during installation.
 - Secure the hexagonal portion of the camshaft using a wrench to loosen the bolts.

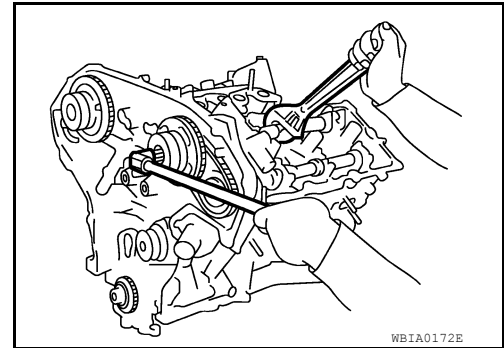

11. Remove the secondary timing chains with camshaft sprockets.
- Rotate camshaft slightly, and slacken timing chain of timing chain tensioner side.
 - Insert metal or resin plate [0.5 mm (0.020 in)] into guide between timing chain and chain tensioner plunger. Remove cam sprocket and secondary timing chain with timing chain removed from guide groove.

CAUTION:

Chain tensioner plunger can move, while stopper pin is inserted in tensioner. Plunger can come out of tensioner when timing chain is removed. Use caution during removal.

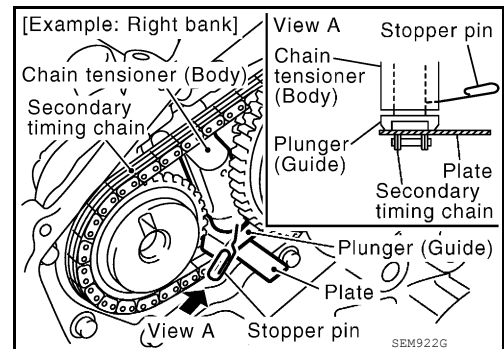

- Intake camshaft sprocket is two-for-one structure of primary and secondary sprockets.
- Handle the intake sprockets as an assembly.

CAUTION:

- Avoid impact or dropping the intake sprockets.
- Do not disassemble the intake sprockets (do not loosen bolts (A) and (B) as shown).

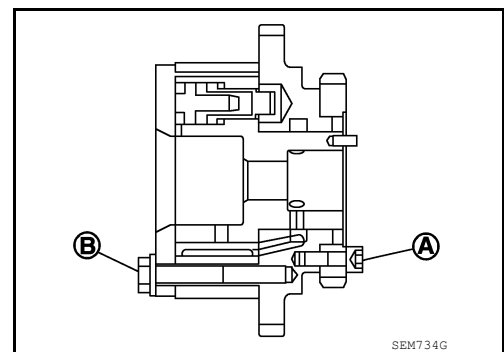

12. Remove the chain tension guide.

TIMING CHAIN

< REMOVAL AND INSTALLATION >

[VQ35DE]

INFOID:000000007420297

Inspection

Check for cracks and any excessive wear of the timing chain. Replace the timing chain as necessary.

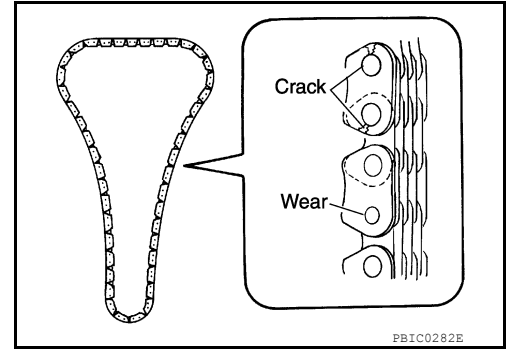

Installation

INFOID:000000007420298

NOTE:

The figure shows the relationship between the mating mark on each timing chain and that on the corresponding sprocket, the components installed.

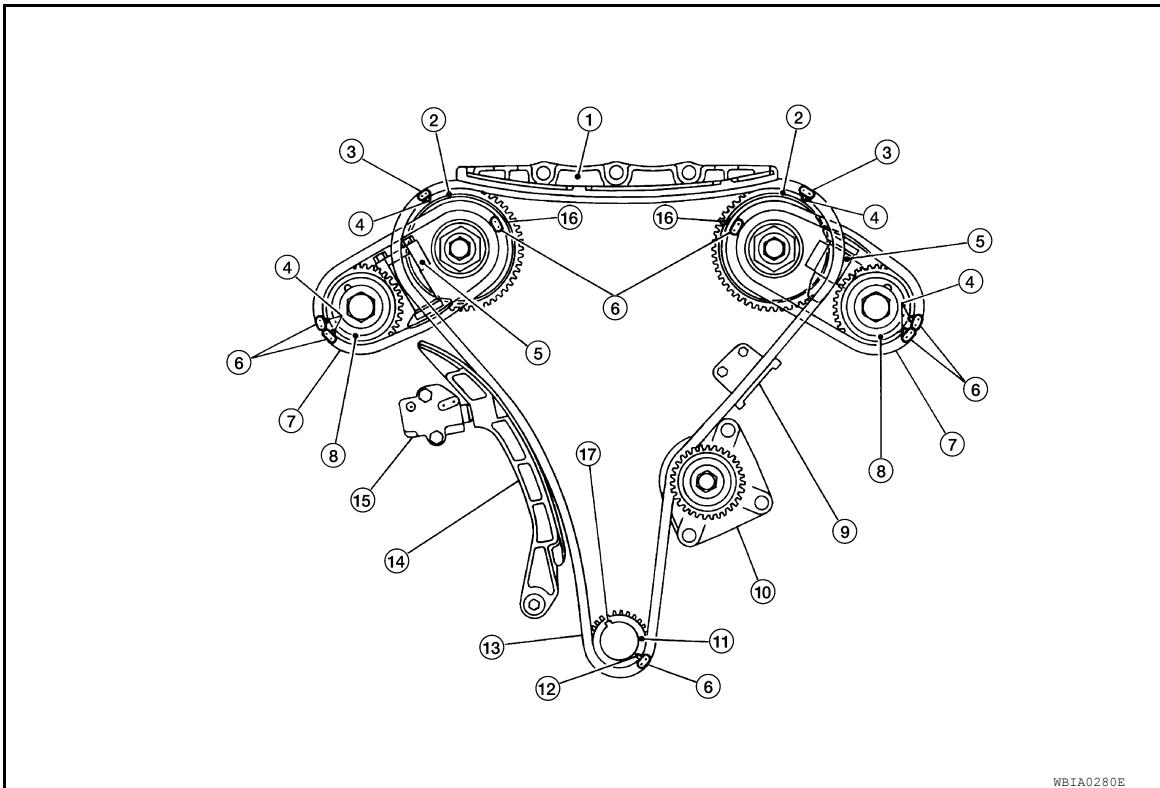

- | | | |
|-----------------------------|-------------------------------------|------------------------------------|
| 1. Internal chain guide | 2. Camshaft sprocket (intake) | 3. Mating mark (pink link) |
| 4. Mating mark (punched) | 5. Secondary timing chain tensioner | 6. Mating mark (orange link) |
| 7. Secondary timing chain | 8. Camshaft sprocket (exhaust) | 9. Tension guide |
| 10. Water pump | 11. Crankshaft sprocket | 12. Mating mark (notched) |
| 13. Primary timing chain | 14. Slack guide | 15. Primary timing chain tensioner |
| 16. Mating mark (back side) | 17. Crankshaft key | |

1. Install the timing chain tension guide.

TIMING CHAIN

[VQ35DE]

< REMOVAL AND INSTALLATION >

2. Position the crankshaft so No. 1 piston is set at TDC on the compression stroke.

NOTE:

- Make sure that the dowel pins (A) and crankshaft key (1) are located as shown.
- Camshaft dowel pin (intake side): at cylinder head upper face side in each bank.
- Camshaft dowel pin (exhaust side): at cylinder head upper face side in each bank.
- Crankshaft key: at cylinder head side of RH bank.

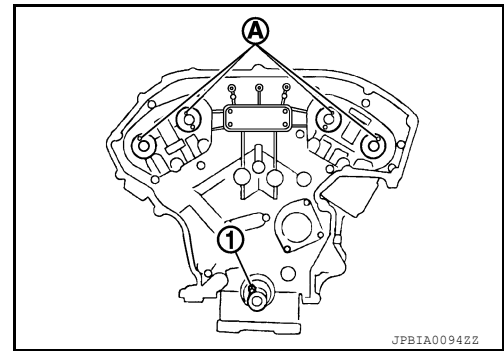

3. Install the secondary timing chains and camshaft sprockets.

CAUTION:

Matching marks between the timing chain and sprockets slip easily. Confirm all matching mark positions repeatedly during the installation process.

- Push the sleeve of the secondary chain tensioner and keep it pressed in with a stopper pin.

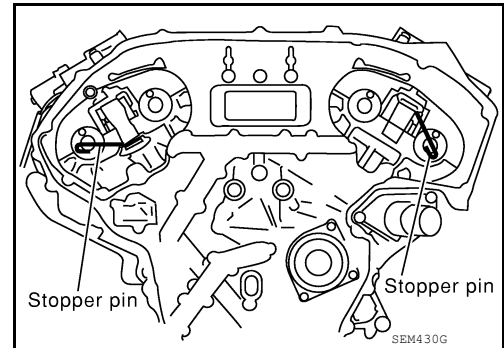

- a. Align the matching marks (4), (5), (7) and (10) on the timing chain (secondary) (8) (orange link) (2) with the ones on the camshaft sprockets (INT) and (EXH) (stamped), and install them.
- Matching marks for the camshaft sprocket (INT) are on the back side of the secondary sprocket.
 - There are two types of matching marks:
 - RH bank use round type (7) and (10).
 - LH bank (6): use oval type (4) and (5).
- b. Align the dowel pin with the pin hole (3) on the camshaft sprocket (INT) side (1), and dowel pin groove (11) with the dowel pin on the camshaft sprocket (EXH) side (9), and install them.
- Camshaft sprocket bolts must be tightened in the next step. Tightening them by hand is enough to prevent the dislocation of the dowel pins (3) and dowel pin grooves (11).

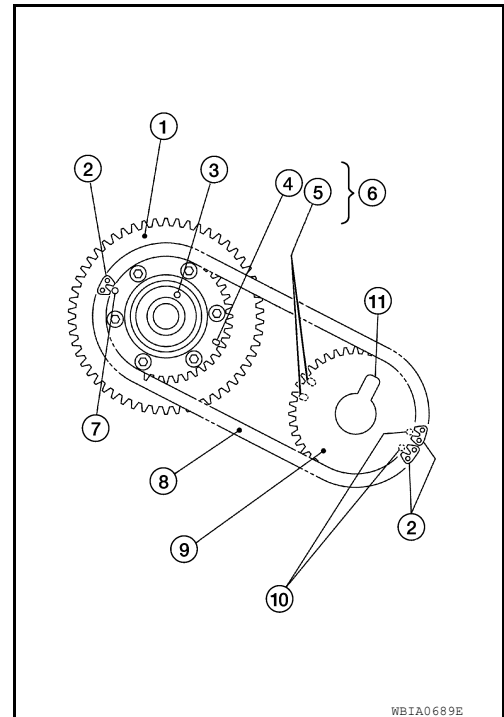

- It may be difficult to visually check the dislocation of mating marks during and after installation. To make the matching easier, make a mating mark on the sprocket teeth in advance with paint.

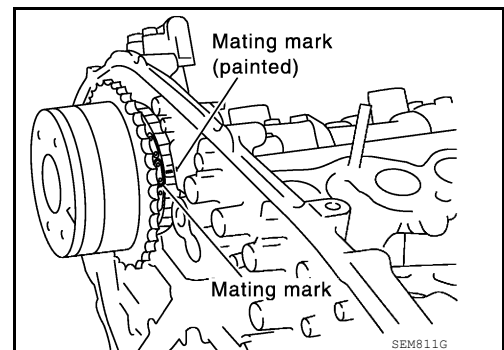

TIMING CHAIN

< REMOVAL AND INSTALLATION >

[VQ35DE]

4. After confirming the mating marks are aligned, tighten the camshaft sprocket bolts.
 - Secure the camshaft using a wrench at the hexagonal portion to tighten the bolts.

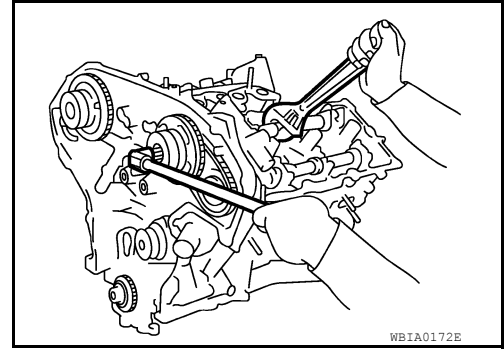

5. Pull the stopper pins out from the secondary timing chain tensioners.

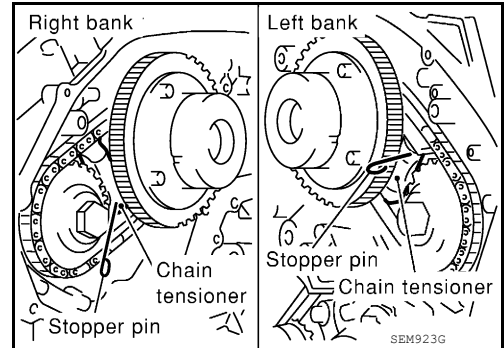

6. Install the crankshaft sprocket on the crankshaft.
 - Make sure the mating marks on the crankshaft sprocket face the front of the engine.

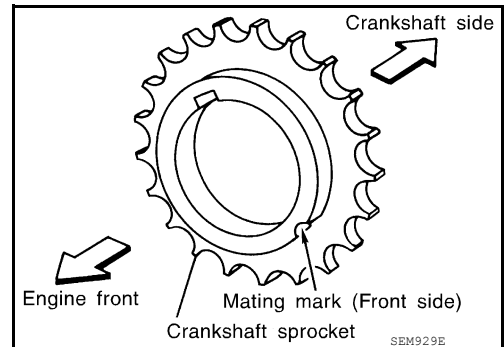

TIMING CHAIN

< REMOVAL AND INSTALLATION >

[VQ35DE]

7. Install the primary timing chain.

- Install primary timing chain so the mating mark punched (B) on camshaft sprocket (C) is aligned with the pink link (A) on the timing chain, while the mating mark (notched) (E) on the crankshaft sprocket (D) is aligned with the orange one (F) on the timing chain, as shown.
- When it is difficult to align mating marks of the primary timing chain with each sprocket, gradually turn the camshaft using a wrench on the hexagonal portion to align it with the mating marks.
- During alignment, be careful to prevent dislocation of mating mark alignments of the secondary timing chains.

(G): Water pump

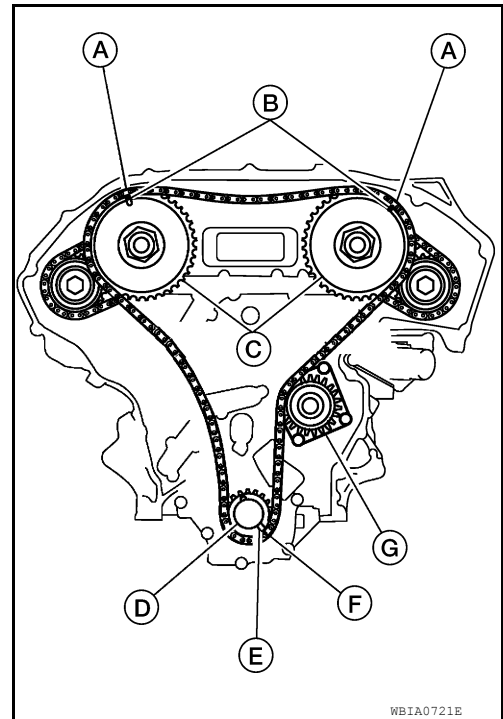

8. Install the internal chain guide and slack guide.

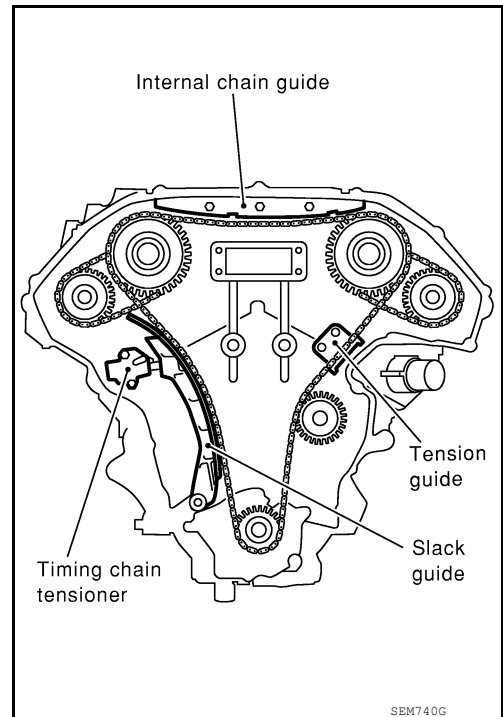

CAUTION:

TIMING CHAIN

[VQ35DE]

< REMOVAL AND INSTALLATION >

Do not overtighten the slack guide bolts. It is normal for a gap to exist under the bolt seats when the bolts are tightened to specification.

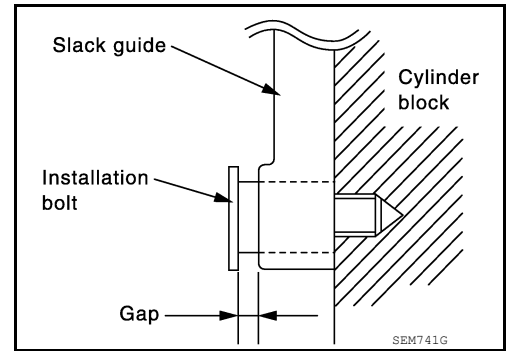

9. Install the timing chain tensioner for the slack guide.
 - When installing the chain tensioner, push in the sleeve and keep it pressed in with the stopper pin.
 - Remove any dirt and foreign materials completely from the back and the mounting surfaces of the chain tensioner.
 - After installation, pull out the stopper pin while pressing the slack guide.
10. Reconfirm that the matching marks on the sprockets and the timing chain have not slipped out of alignment.

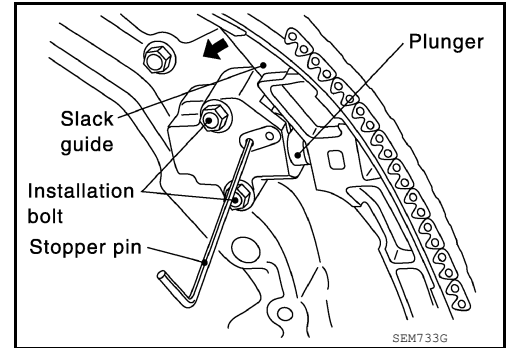

11. Install new O-rings (A) on the rear timing chain case.

CAUTION:
Do not reuse O-rings.

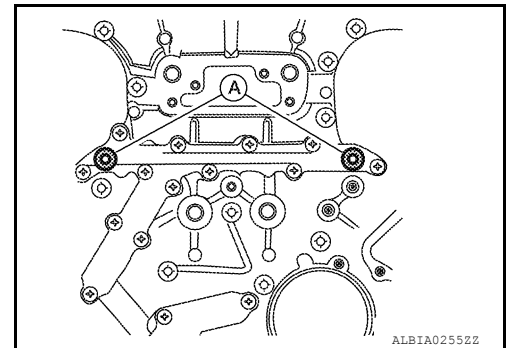

12. Install the front timing chain case. Refer to [EM-163, "Removal and Installation"](#).

REAR TIMING CHAIN CASE

< REMOVAL AND INSTALLATION >

[VQ35DE]

REAR TIMING CHAIN CASE

Component

INFOID:000000007420299

SEC. 120 • 130 • 150 • 210 • 275

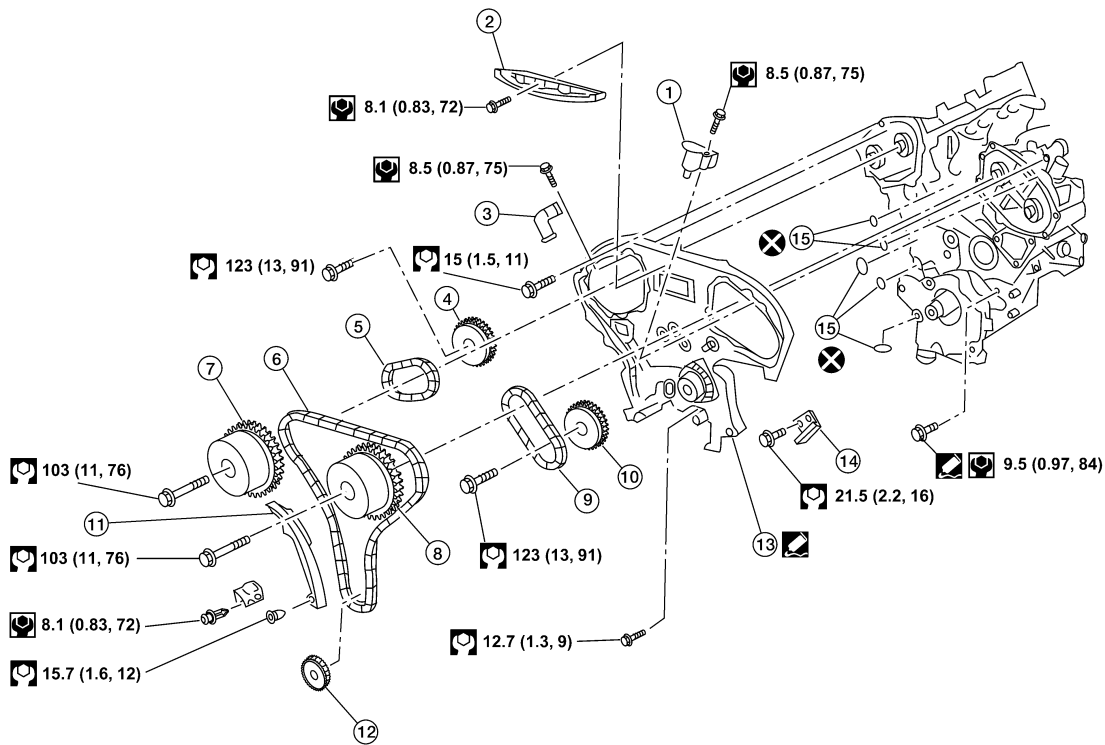

AWBIA0578GB

- | | | |
|-----------------------------|-----------------------------|-----------------------------|
| 1. Timing chain tensioner | 2. Internal chain guide | 3. Timing chain tensioner |
| 4. Camshaft sprocket (EXH) | 5. Timing chain (secondary) | 6. Timing chain (primary) |
| 7. Camshaft sprocket (INT) | 8. Camshaft sprocket (INT) | 9. Timing chain (secondary) |
| 10. Camshaft sprocket (EXH) | 11. Slack guide | 12. Crankshaft sprocket |
| 13. Rear timing chain case | 14. Tension guide | 15. O-ring |

- Refer to [EM-113. "Precaution for Liquid Gasket"](#).
- Before installation, wipe off any protruding sealant.

CAUTION:

- After removing timing chain, do not turn the crankshaft and camshaft separately, or the valves will strike the pistons.
- When installing camshafts, chain tensioners, oil seals, or other sliding parts, lubricate contacting surfaces with new engine oil.
- Apply new engine oil to bolt threads and seat surfaces when installing camshaft sprockets, camshaft brackets, and crankshaft pulley.
- Before disconnecting fuel hose, release fuel pressure. Refer to [EC-700. "Inspection"](#).
- Before removing the upper oil pan, remove the crankshaft position sensor (POS).
- Be careful not to damage sensor edges.
- Do not spill engine oil or coolant on drive belt.

REAR TIMING CHAIN CASE

< REMOVAL AND INSTALLATION >

[VQ35DE]

Removal and Installation

INFOID:000000007420300

REMOVAL

1. Remove the engine assembly. Refer to [EM-210, "Removal and Installation"](#).
2. Remove the oil pan lower and upper. Refer to [EM-145, "Removal and Installation \(Upper Oil Pan\)"](#).
3. Remove the front timing chain case. Refer to [EM-163, "Removal and Installation"](#).
4. Remove the primary and secondary timing chains. Refer to [EM-171, "Removal"](#).
5. Remove the rear timing chain case.

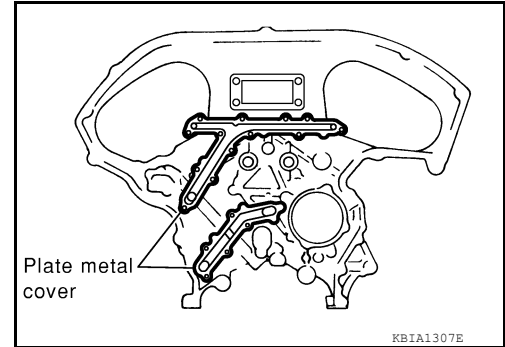

- a. Loosen and remove the rear timing chain case bolts in the order as shown.

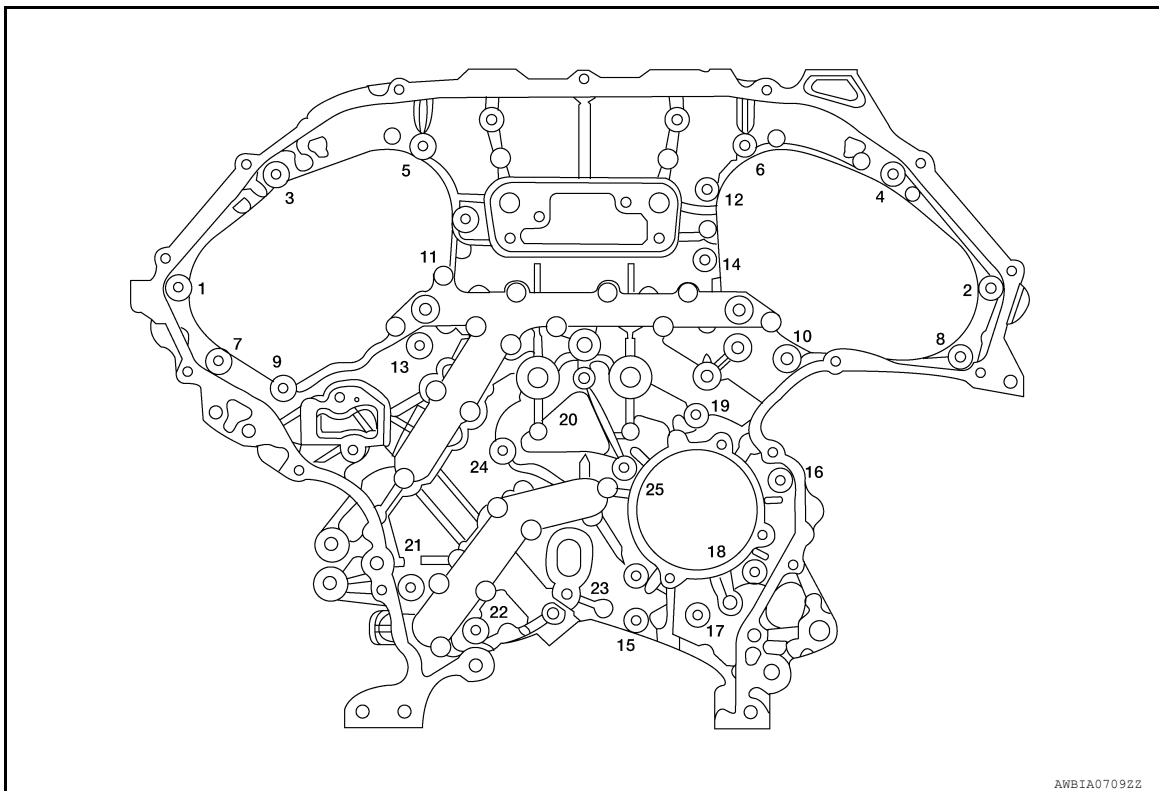

CAUTION:

- Do not remove the plate metal cover for the oil passage.
- After removing the chain case, do not apply any load to the case that might bend it.

REAR TIMING CHAIN CASE

< REMOVAL AND INSTALLATION >

[VQ35DE]

- b. Cut the sealant using Tool and remove the rear timing chain case.

Tool number : KV10111100 (J-37228)

CAUTION:

- Be careful not to damage the mating surface.
- Do not insert a screwdriver, this will damage the mating surfaces.

- c. Slide the Tool by tapping its side with a hammer to remove the rear timing chain case from the cylinder block.

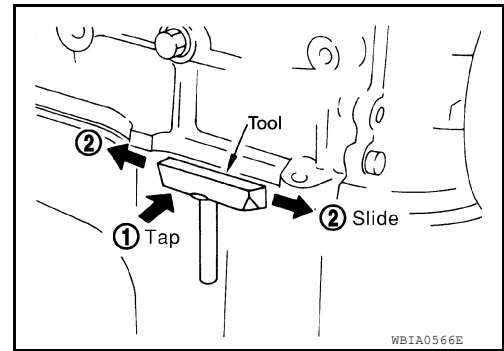

6. Remove O-rings to timing chain case and cylinder block.

CAUTION:

Do not reuse O-rings.

7. Use a scraper to remove all of the old Silicone RTV Sealant from the front and rear timing chain case and opposite mating surfaces.

CAUTION:

Do not damage the mating surfaces.

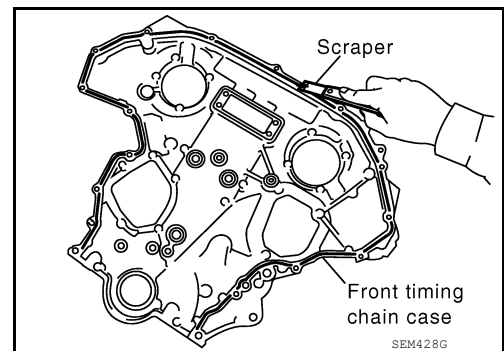

8. Remove all old Silicone RTV Sealant from all the bolt holes and bolts.

CAUTION:

Do not damage the threads or mating surfaces.

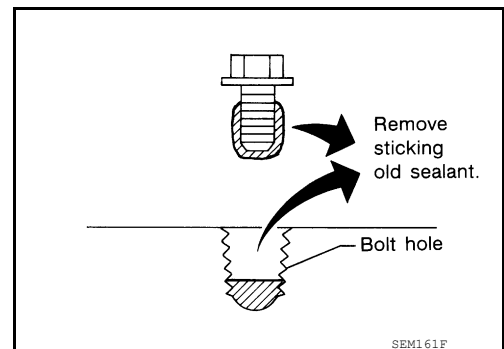

INSTALLATION

1. Install O-rings on cylinder block.

CAUTION:

Do not reuse O-rings.

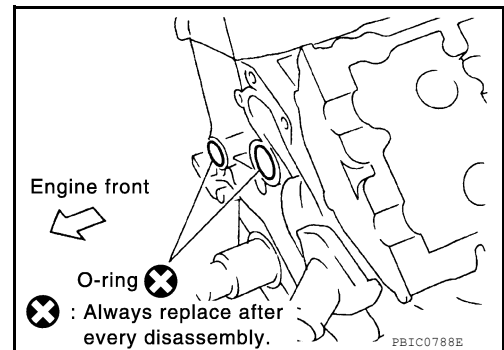

2. Apply Genuine Silicone RTV Sealant or equivalent, to the rear timing chain case using Tool as shown. Refer to [GI-15. "Recommended Chemical Products and Sealants"](#).

Tool number : WS39930000 (—)

CAUTION:

REAR TIMING CHAIN CASE

< REMOVAL AND INSTALLATION >

[VQ35DE]

- For (a), completely remove excess liquid gasket exposed to engine coolant.
- Apply liquid gasket on installation position of water pump and cylinder completely.

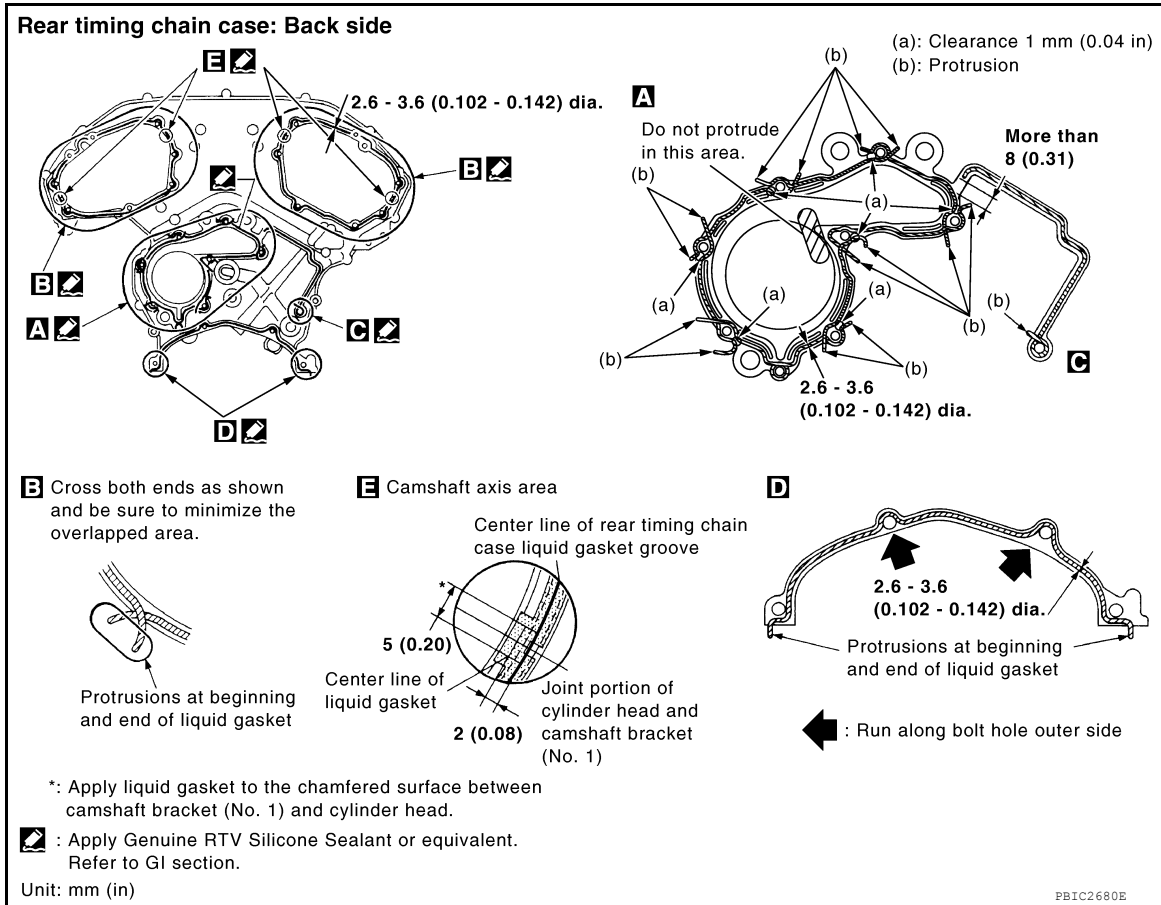

- Align the rear timing chain case and water pump assembly with the dowel pins (RH and LH) on the cylinder block and install the case. Make sure the O-rings stay in place during installation.

CAUTION:
Do not reuse O-rings.

REAR TIMING CHAIN CASE

< REMOVAL AND INSTALLATION >

[VQ35DE]

- a. Tighten the bolts in the numerical order as shown. There are two bolt lengths used. Follow the chart below for proper bolt length specifications.

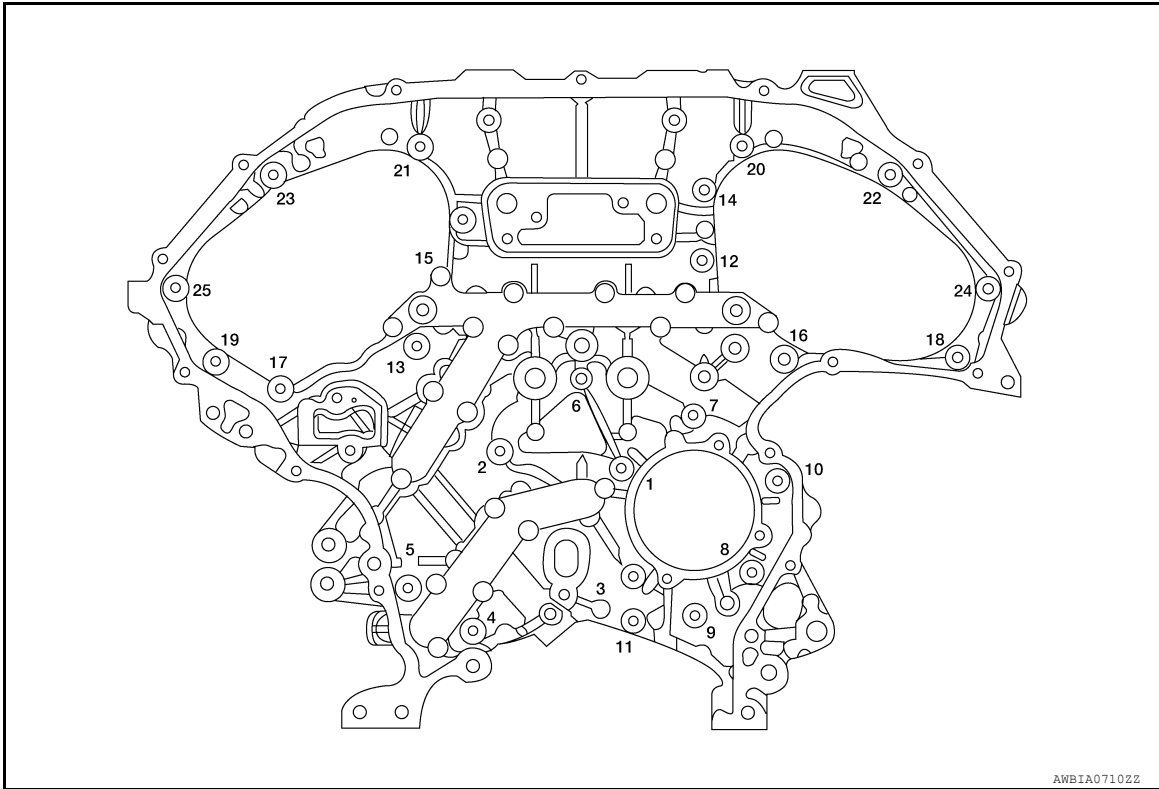

Bolt length	Bolt position	Torque specification
20 mm (0.79 in)	1, 2, 3, 6, 7, 8, 9, 10	12.7 N·m (1.3 kg-m, 9 ft-lb)
16 mm (0.63 in)	4, 5, 11	12.7 N·m (1.3 kg-m, 9 ft-lb)
16 mm (0.63 in)	12 - 25	12.7 N·m (1.3 kg-m, 9 ft-lb)

- b. After all bolts are initially tightened, retighten them to the specification in the numerical order as shown.
4. Install the primary and secondary timing chains. Refer to [EM-174. "Installation"](#).
 5. Install the front timing chain case. Refer to [EM-163. "Removal and Installation"](#).
 6. Install the oil pan upper and lower. Refer to [EM-145. "Removal and Installation \(Upper Oil Pan\)"](#).
 7. Install the engine assembly. Refer to [EM-210. "Removal and Installation"](#).

CAMSHAFT

< REMOVAL AND INSTALLATION >

[VQ35DE]

CAMSHAFT

Removal and Installation

INFOID:000000007420301

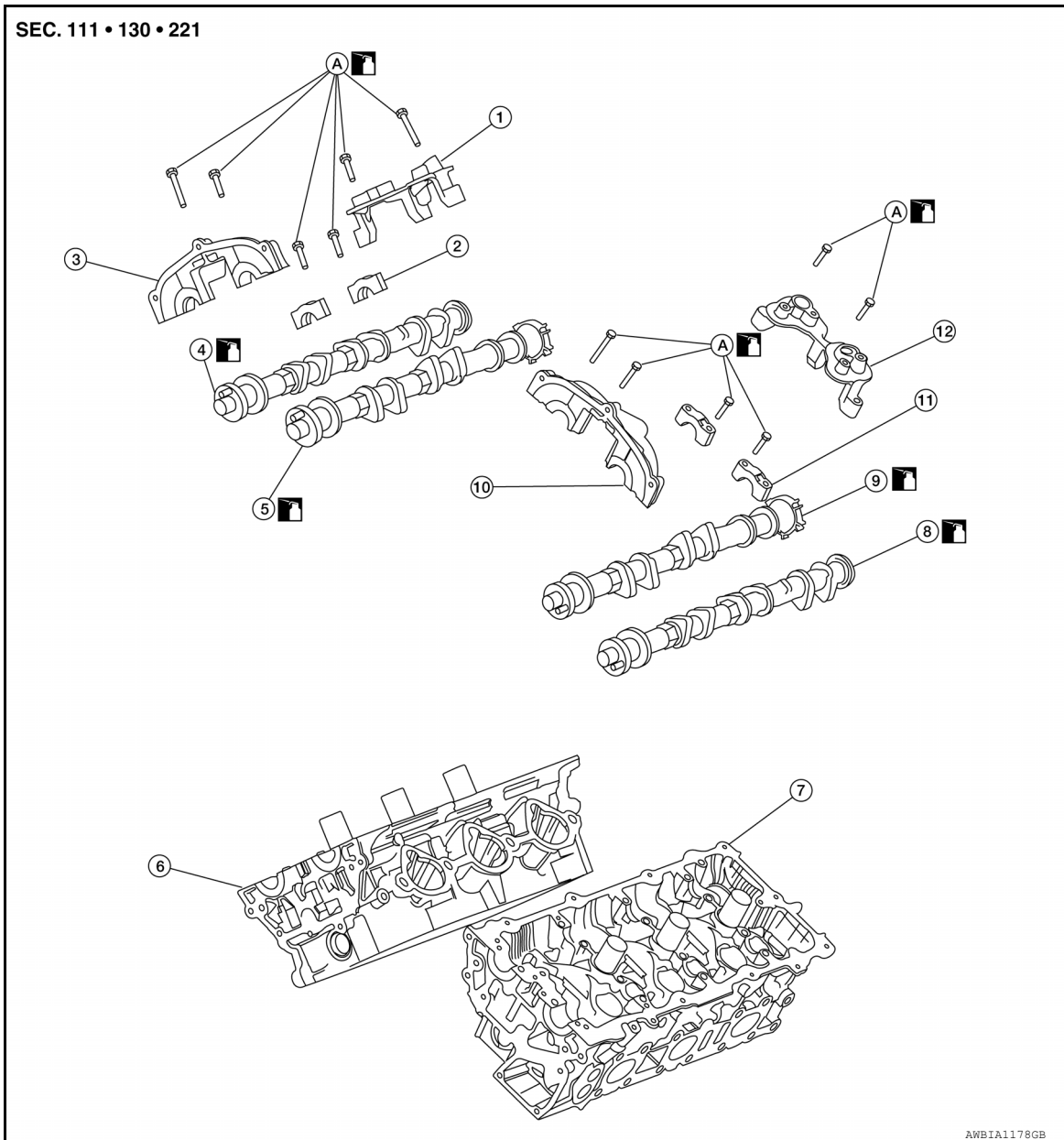

- | | | |
|--|-----------------------|---|
| 1. Camshaft position sensor bracket (RH) | 2. Camshaft brackets | 3. No. 1 camshaft bracket (RH) |
| 4. Camshaft (EXH) RH | 5. Camshaft (INT) RH | 6. Cylinder head (RH) |
| 7. Cylinder head (LH) | 8. Camshaft (EXH) LH | 9. Camshaft (INT) LH |
| 10. No. 1 camshaft bracket (LH) | 11. Camshaft brackets | 12. Camshaft position sensor bracket (LH) |
| A. Follow installation procedure | | |

CAUTION:

Apply new engine oil to parts marked in illustration before installation.

REMOVAL

1. Remove the timing chains. Refer to [EM-171. "Removal"](#).

CAMSHAFT

< REMOVAL AND INSTALLATION >

[VQ35DE]

2. Remove camshaft position brackets (RH shown LH similar).

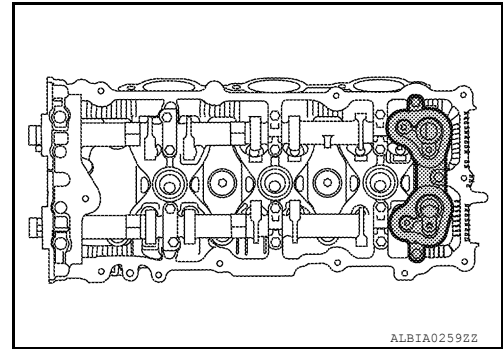

3. Remove the intake and exhaust camshaft brackets and the camshafts.

- Mark the camshafts, camshaft brackets, and bolts so they are placed in the same position and direction for installation.
- Equally loosen the camshaft bracket bolts in several steps in the numerical order as shown.

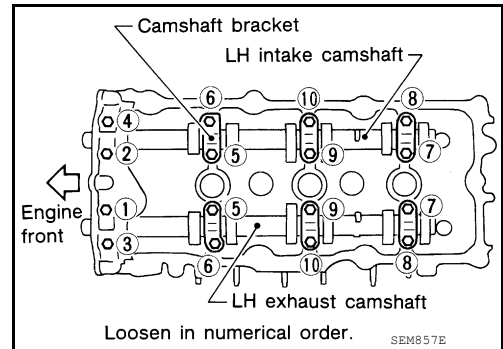
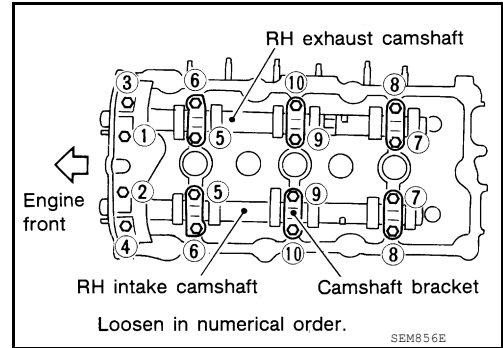

4. Remove valve lifters, if necessary.

NOTE:

Identify installation positions to ensure proper installation.

5. Remove secondary timing chain tensioner from cylinder head
- Remove secondary tensioner with its stopper pin attached.

NOTE:

Stopper pin was attached when secondary timing chain was removed.

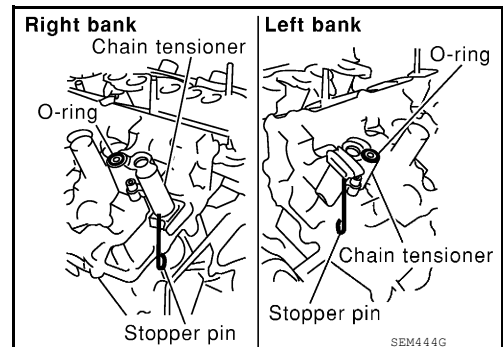

INSTALLATION

CAMSHAFT

[VQ35DE]

< REMOVAL AND INSTALLATION >

1. Before installation, remove any old Silicone RTV Sealant from component mating surfaces using a scraper.
 - Remove the old Silicone RTV Sealant from the bolt holes and threads.
 - Do not scratch or damage the mating surfaces.

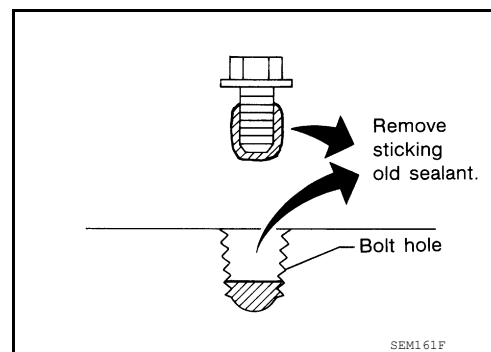

2. Before installing the front cam bracket, remove the old Silicone RTV Sealant from the mating surface using a scraper.
 - Do not scratch or damage the mating surface.

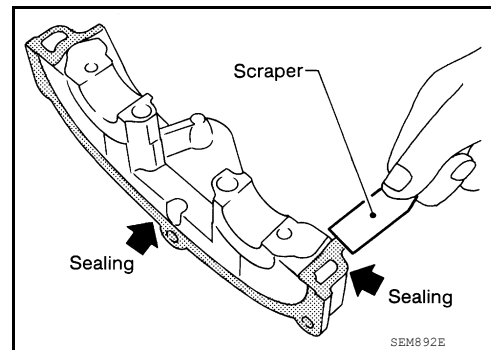

3. Turn the crankshaft until No. 1 piston is set at TDC on the compression stroke.
 - The crankshaft key should line up with the right bank cylinder center line as shown.

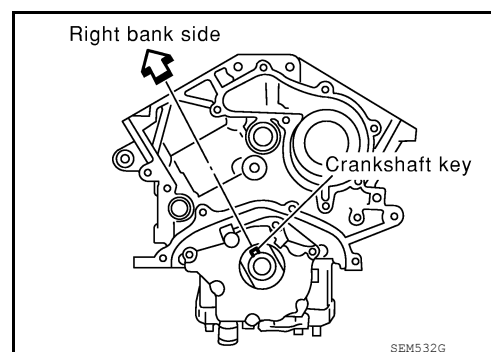

4. Install camshaft chain tensioners on both sides of cylinder head. Refer to [EM-163. "Removal and Installation"](#).

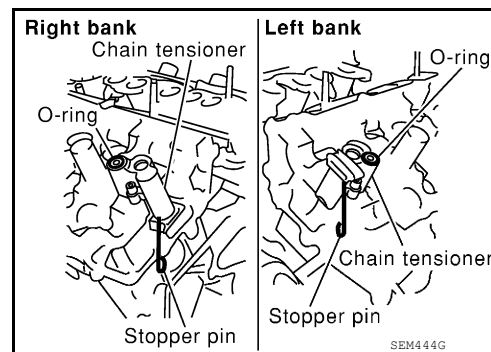

5. Install valve lifters, if removed.
NOTE:
Install them in original positions.

CAMSHAFT

[VQ35DE]

< REMOVAL AND INSTALLATION >

6. Install exhaust and intake camshafts and camshaft brackets.
 - Intake camshaft has a drill mark on camshaft sprocket mounting flange.

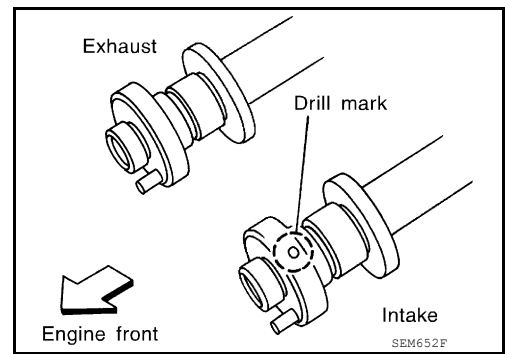

- Follow your identification marks made during removal, or follow the identification marks that are present on the new camshaft components for proper placement and direction of the components.

Bank	INT/EXH	ID mark	Drill mark	Paint marks	
				M1	M2
RH	INT	1A	Yes	Blue	No
	EXH	1C	No	No	Blue
LH	INT	1B	Yes	Blue	No
	EXH	1D	No	No	Blue

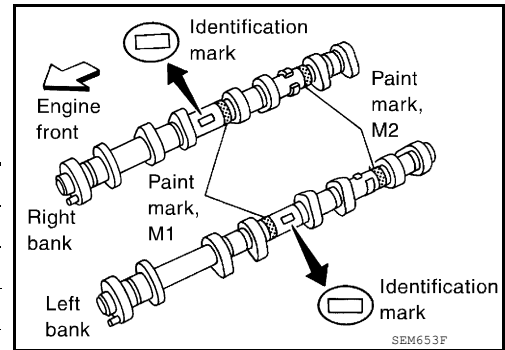

- Position the camshaft dowel pins (A) as shown.

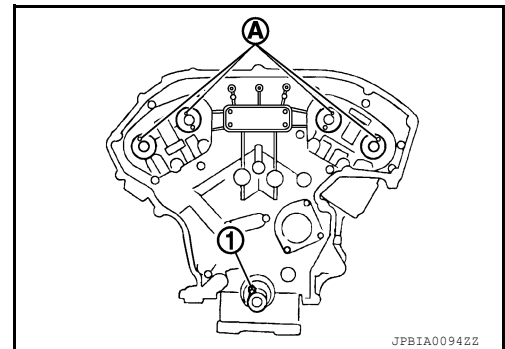

A
EM
C
D
E
F
G
H
I
J
K
L
M
N
O
P

CAMSHAFT

[VQ35DE]

< REMOVAL AND INSTALLATION >

- Before installing camshaft brackets, apply sealant to mating surface of No. 1 camshaft bracket.
 - Use **Genuine Silicone RTV Sealant, or equivalent. Refer to [GI-15, "Recommended Chemical Products and Sealants"](#).**

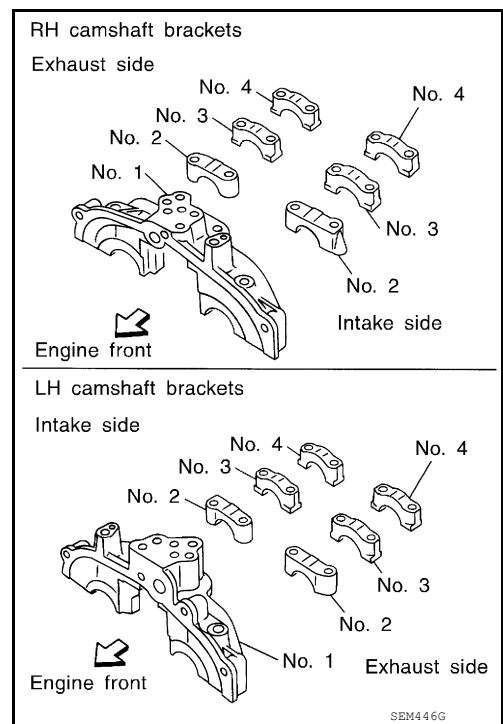

- Before installation, wipe off any protruding sealant.
- Refer to [EM-113, "Precaution for Liquid Gasket"](#).

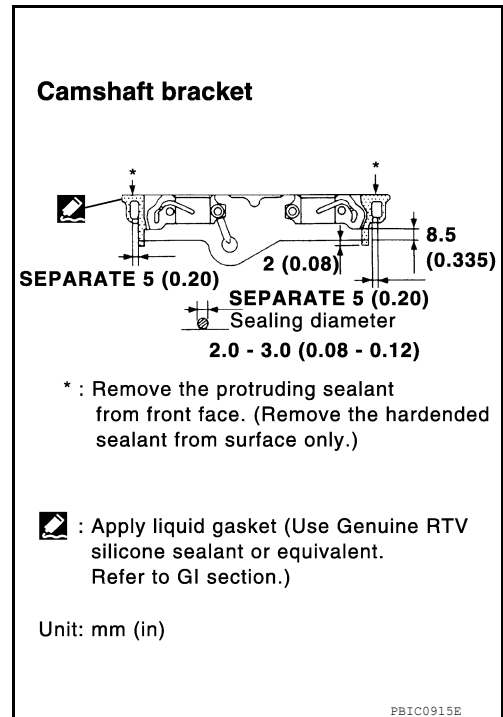

- Install camshaft brackets in their original positions and direction. Align the stamp marks as shown.
- If checking and adjusting any part of valve assembly or camshaft, check valve clearance according to the reference data. Refer to [EM-127, "Valve Clearance"](#).

Valve clearance (cold) Intake : 0.26 - 0.34 mm (0.010 - 0.013 in)

Valve clearance (cold) Exhaust : 0.29 - 0.37 mm (0.011 - 0.015 in)

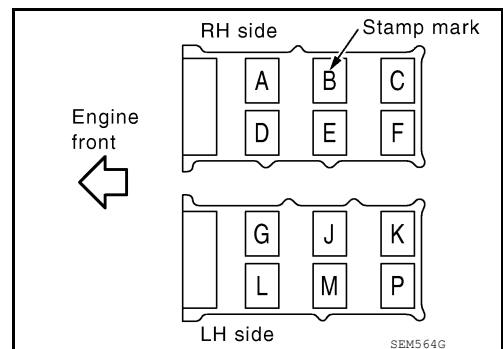

CAMSHAFT

< REMOVAL AND INSTALLATION >

[VQ35DE]

- Tighten the camshaft brackets in the three steps, in numerical order as shown.

1	1.96 N·m (0.2 kg-m, 17 in-lb)	Tighten No.s 7 - 10, then tighten 1 - 6 in numerical order as shown.
2	5.88 N·m (0.6 kg-m, 52 in-lb)	Tighten in numerical order as shown.
3	10.41 N·m (1.10 kg-m, 8 ft-lb)	Tighten No. 1 - 6 in the numerical order as shown.

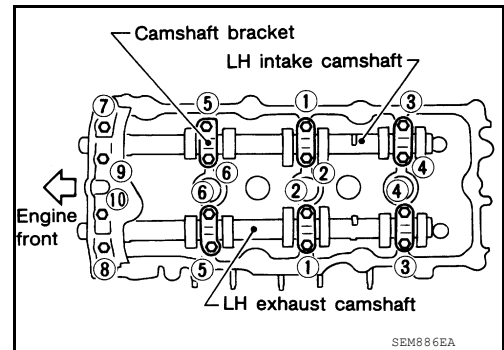
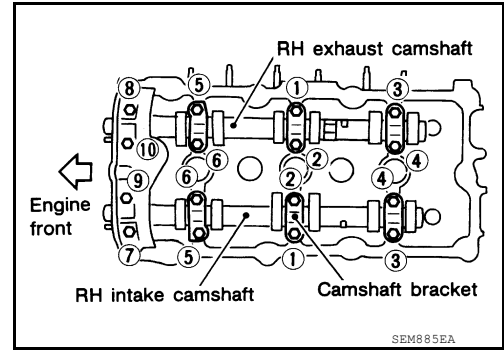

8. Measure difference in levels between front end faces of No. 1 camshaft bracket and cylinder head.

Standard : - 0.14 mm (- 0.0055 in)

- If measurement is outside the specified range, re-install camshaft and camshaft bracket.

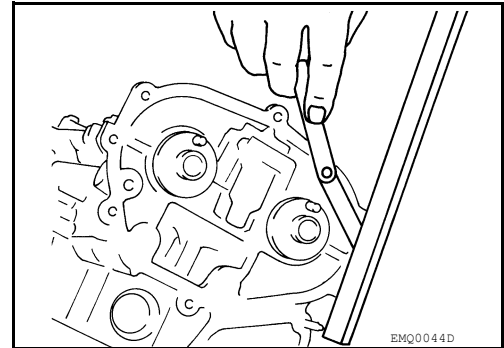

9. Install camshaft position sensor (PHASE) (RH and LH bank.)
 10. Install the timing chains. Refer to [EM-174. "Installation"](#).

INSPECTION AFTER REMOVAL

Camshaft Visual Check

Check camshaft for scratches, seizure and wear. Replace if necessary.

Camshaft Runout

- Put V-block on precise flat bed and support No. 2 and No. 4 journal of camshaft as shown.
- Set dial gauges vertically to No. 3 journal as shown.
- Turn camshaft in one direction slowly by hand, measure the camshaft runout on the dial gauges.
 - Runout is the largest indicator reading after one full revolution.

Camshaft Runout (total indicator reading)

Standard : Less than 0.02 mm (0.0008 in)

Limit : 0.05 mm (0.0020 in)

4. If actual runout exceeds the limit, replace the camshaft.

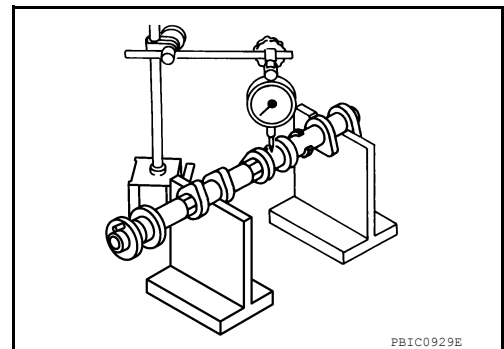

CAMSHAFT

< REMOVAL AND INSTALLATION >

[VQ35DE]

Camshaft Cam Lobe Height

1. Measure camshaft cam lobe height as shown. Refer to [EM-237](#), "[Camshaft](#)".
2. If wear has reduced the lobe height below specifications, replace the camshaft.

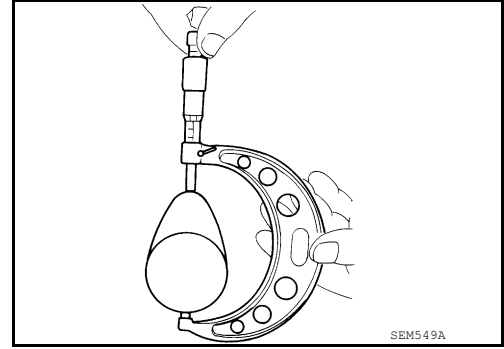

Camshaft Journal Clearance

Outer Diameter of Camshaft Journal

- Measure outer diameter of camshaft journal as shown.

Standard outer diameter : 25.935 - 25.955 mm
No.1 (1.0211 - 1.0218 in)

Standard outer diameter : 23.445 - 23.465 mm
No.2, 3, 4 (0.9230 - 0.9238 in)

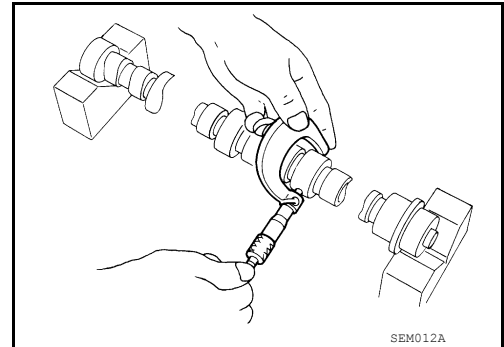

Inner Diameter of Camshaft Bracket

1. Tighten camshaft bracket bolt with specified torque.
2. Using inside micrometer, measure inner diameter (A) of camshaft bearing.

Standard inner diameter : 26.000 - 26.021 mm
No.1 (1.0236 - 1.0244 in)

Standard inner diameter : 23.500 - 23.521 mm
No.2, 3, 4 (0.9252 - 0.9260 in)

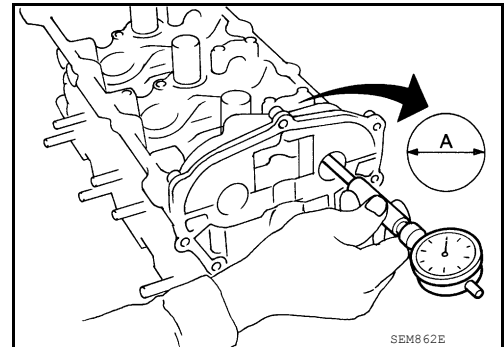

Calculation of Camshaft Journal Clearance

(Journal clearance) = (inner diameter of camshaft bracket) – (outer diameter of camshaft journal)

Standard : 0.045 - 0.086 mm (0.0018 - 0.0034 in)
No.1

Standard : 0.035 - 0.076 mm (0.0014 - 0.0030 in)
No.2, 3, 4

Limit : 0.15 mm (0.0059 in)

- When out of the specified range, replace either or both camshaft and cylinder head.

NOTICE:

Inner diameter of camshaft bracket is manufactured together with cylinder head. Replace the whole cylinder head assembly.

Camshaft End Play

1. Install the camshaft in the cylinder head.

CAMSHAFT

[VQ35DE]

< REMOVAL AND INSTALLATION >

2. Install dial gauge in thrust direction on front end of camshaft. Measure end play when camshaft is moved forward/backward (in direction to axis) as shown.

Standard : 0.115 - 0.188 mm (0.0045 - 0.0074 in)

Limit : 0.24 mm (0.0094 in)

- If out of the specified range, replace with new camshaft and measure again.
- If out of the specified range again, replace with new cylinder head.

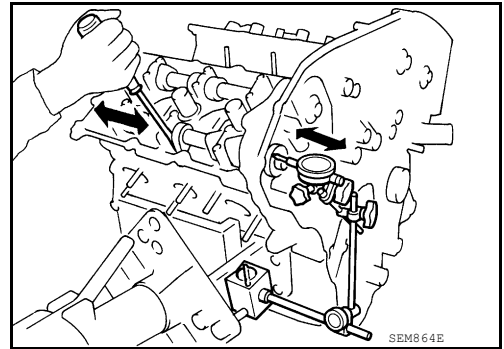

Camshaft Sprocket Runout

1. Put V-block on precise flat bed and support No. 2 and No. 4 journal of camshaft as shown.
2. Install camshaft sprocket on camshaft.
3. Measure camshaft sprocket runout.

Runout (total indicator reading) : Less than 0.15 mm (0.0059 in)

4. If sprocket runout exceeds the limit, replace camshaft sprocket.

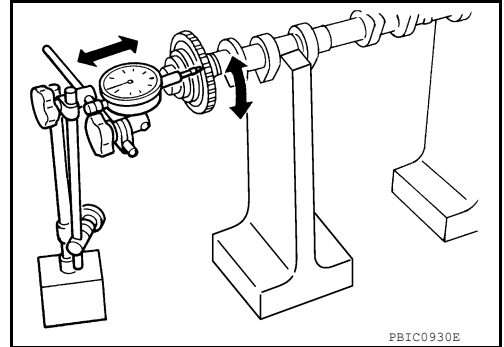

Valve Lifter

- Check if the surface of the valve lifter has any excessive wear or cracks, replace as necessary.

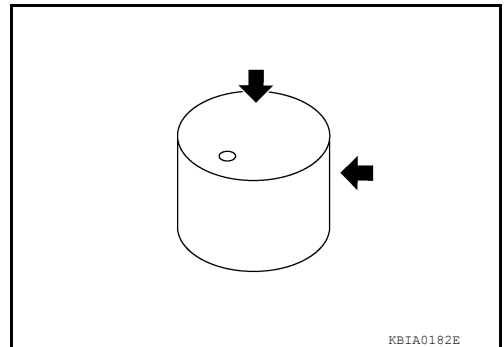

Valve Lifter Clearance

Outer Diameter of Valve Lifter

- Measure the outer diameter of the valve lifter. Refer to [EM-237](#), "[Camshaft](#)".
- If out of the specified range, replace the valve lifter.

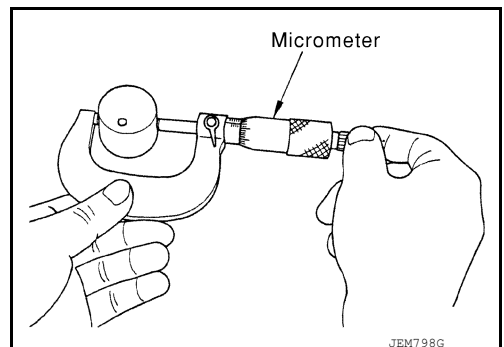

Valve Lifter Bore Diameter

CAMSHAFT

[VQ35DE]

< REMOVAL AND INSTALLATION >

- Using inside micrometer, measure diameter of valve lifter bore of cylinder head. Refer to [EM-239, "Cylinder Head"](#).
- If out of the specified range, replace the cylinder head assembly.

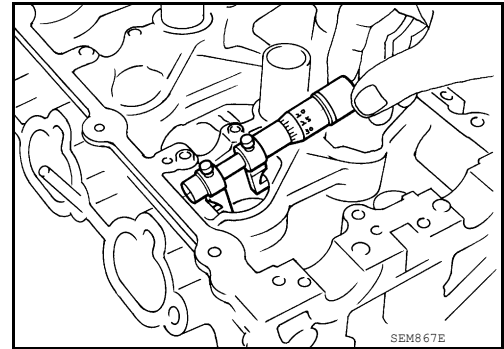

Calculation of Valve Lifter Clearance

- (Valve lifter clearance) = (hole diameter for valve lifter) – (outer diameter of valve lifter) Refer to [EM-237, "Camshaft"](#) and [EM-239, "Cylinder Head"](#).
- If out of specified range, replace either or both valve lifter and cylinder head assembly.

Inspection after Installation

INFOID:000000007420302

INSPECTION OF CAMSHAFT SPROCKET (INT) OIL GROOVE

WARNING:

Check when engine is cold so as to prevent burns from any splashing engine oil.

CAUTION:

Perform this inspection only when DTC P0011 is detected in self-diagnostic results of CONSULT and it is directed according to inspection procedure of EC section. Refer to [EC-443, "Diagnosis Procedure"](#).

1. Check engine oil level. Refer to [LU-25, "Inspection"](#).
2. Perform the following procedure so as to prevent the engine from being unintentionally started while checking.
 - a. Release fuel pressure. Refer to [EC-700, "Inspection"](#).
 - b. Disconnect ignition coil and injector harness connectors if practical.
3. Remove IVT control solenoid valve.
4. Crank engine, and then make sure that engine oil comes out from IVT control cover oil hole (◀). End cranking after checking.

WARNING:

Be careful not to touch rotating parts (drive belts, idler pulley, and crankshaft pulley, etc.).

CAUTION:

- Engine oil may squirt from IVT control solenoid valve installation hole during cranking. Use a shop cloth to prevent engine oil from splashing on worker, engine components and vehicle.
- Do not allow engine oil to get on rubber components such as drive belts or engine mount insulators. Immediately wipe off any splashed engine oil.

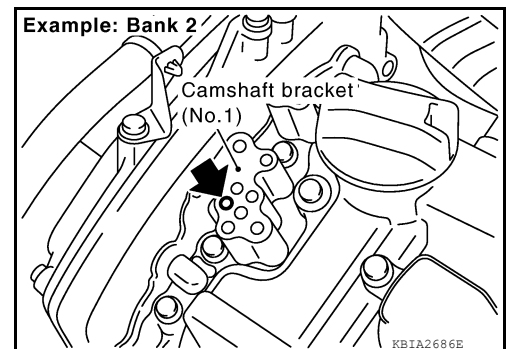

5. Clean oil groove between oil strainer and IVT control solenoid valve if engine oil does not come out from IVT control cover oil hole.
6. Remove components between IVT control solenoid valve and camshaft sprocket (INT), and then check each oil groove for clogging.
 - Clean oil groove if necessary.
7. After inspection, installation of the remaining components is in the reverse order of removal.

OIL SEAL

Removal and Installation of Valve Oil Seal

INFOID:000000007420303

REMOVAL

1. Turn crankshaft until the cylinder requiring new oil seals is at TDC. This will prevent valve from dropping into cylinder.

CAUTION:

When rotating crankshaft, be careful to avoid scarring the front cover with the timing chain.

2. Remove camshaft relating to valve oil seal to be removed. Refer to [EM-184, "Removal and Installation"](#).
3. Remove valve lifters. Refer to [EM-184, "Removal and Installation"](#).
4. Remove valve collet, valve spring retainer and valve spring using Tool.

CAUTION:

When working, take care not to damage valve lifter holes.

Tool numbers : KV10116200 (J-26336-A)
 : KV10115900 (J-26336-20)
 : KV10109230 (—)

- Compress valve spring using Tool attachment, adapter. Remove valve collet with magnet hand.

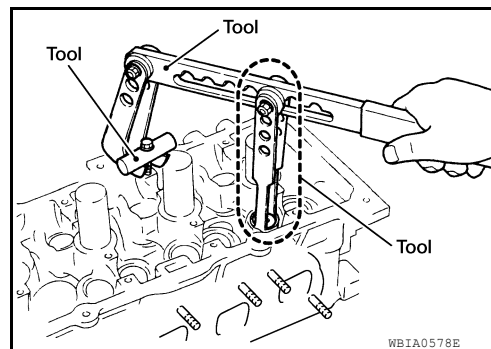

5. Remove valve oil seal using Tool.

Tool number : KV10107902 (J-38959)

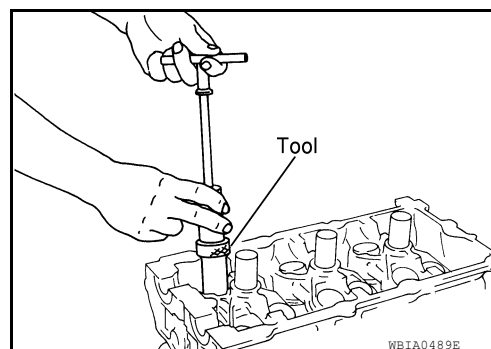

INSTALLATION

1. Apply new engine oil to new valve oil seal joint surface and seal lip.
2. Press in valve oil seal to height (H) using Tool to specified height.

Tool number : — (J-39386)

NOTE:

Dimension (H): height measured before valve spring seat installation.

Intake and exhaust : 14.3 - 14.9 mm (0.563 - 0.587 in)

3. Installation of the remaining components is in the reverse order of removal.

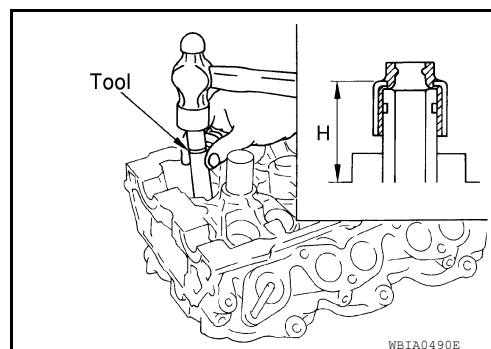

Removal and Installation of Front Oil Seal

INFOID:000000007420304

REMOVAL

1. Remove the following parts:
 - Fender protector side cover (RH). Refer to [EXT-22, "Removal and Installation"](#) (Coupe models) or [EXT-46, "Removal and Installation"](#) (Sedan models).

OIL SEAL

[VQ35DE]

< REMOVAL AND INSTALLATION >

- Drive belts. Refer to [EM-123, "Removal and Installation"](#).
2. Remove the crankshaft pulley as follows:
 - a. Remove the access plate and lock the ring gear using Tool.

Tool number : — (J-50288)

CAUTION:

Do not damage the ring gear teeth, or the signal plate teeth behind the ring gear when installing Tool.

- b. Loosen crankshaft pulley bolt and locate bolt seating surface at 10 mm (0.39 in) from its original position.
- c. Position a suitable tool at recess hole of crankshaft pulley to remove crankshaft pulley.

CAUTION:

Do not position a puller claw on crankshaft pulley periphery.

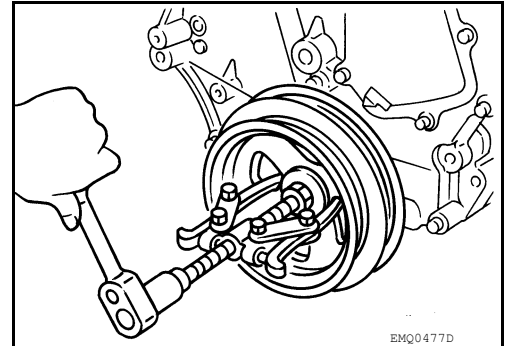

3. Remove front oil seal from front cover using a suitable tool.

CAUTION:

Be careful not to damage front cover or crankshaft.

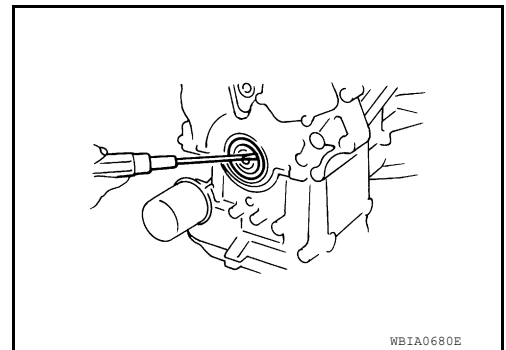

INSTALLATION

1. Apply new engine oil to new oil seal and install.
 - Install new oil seal in the direction as shown.

CAUTION:

- **Do not reuse oil seal.**
- **Press fit straight and avoid causing burrs or tilting the oil seal.**

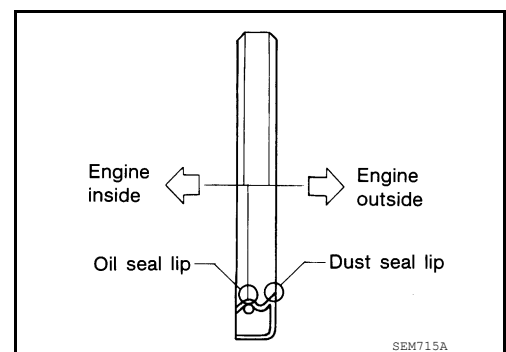

- Press-fit oil seal until it becomes flush with the timing chain case end face, using suitable tool.
- Make sure the garter spring in the oil seal is in position and seal lip is not inverted.

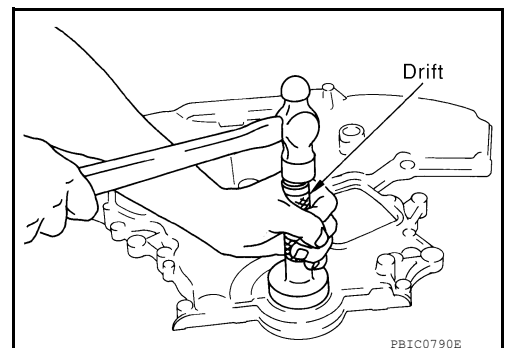

2. Install crankshaft pulley and tighten the bolt in two steps.
 - Lubricate thread and seat surface of the bolt with new engine oil.
 - For the second step angle tighten using Tool.

Step 1 : 44 N·m (4.5 kg-m, 32 ft-lb)
Step 2 : 84° - 90° degrees clockwise

Tool number : KV10112100 (BT-8653-A)

3. Remove Tool and install the access plate.

Tool number : — (J-50288)

CAUTION:

Do not damage the ring gear teeth, or the signal plate teeth behind the ring gear, when removing the Tool.

4. Installation of the remaining components is in the reverse order of removal.

Removal and Installation of Rear Oil Seal

INFOID:000000007420305

REMOVAL

1. Remove the engine assembly. Refer to [EM-210. "Removal and Installation"](#).
2. Remove drive plate. Refer to [EM-214. "Disassembly and Assembly"](#).
3. Drain engine oil. Refer to [MA-26. "ENGINE OIL : Changing Engine Oil"](#).
4. Remove the upper oil pan and oil strainer. Refer to [EM-145. "Removal and Installation \(Upper Oil Pan\)"](#).
5. Remove rear oil seal retainer using Tool.

Tool Number : KV10111100 (J-37228)

CAUTION:

- Be careful not to damage mating surface.
- If rear oil seal retainer is removed, replace it with a new one.

NOTE:

Rear oil seal and retainer form a single part and are replaced as an assembly.

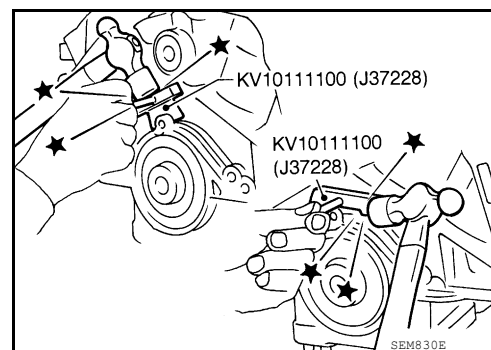

INSTALLATION

1. Remove old liquid gasket material from mating surface of cylinder block and oil pan using a suitable scraper.
2. Install the rear oil seal retainer using Tool (A).

CAUTION:

Do not reuse rear oil seal.

Tool number : — (J-47128)

- a. Loosen the wing nut (B) on the end of the Tool (A).
- b. Insert the arbor (D) into the crankshaft pilot hole until the outer lip (C) of the Tool (A) covers the edge of the crankshaft sealing surface.
- c. Tighten the wing nut (B) to secure the Tool (A) to the crankshaft.

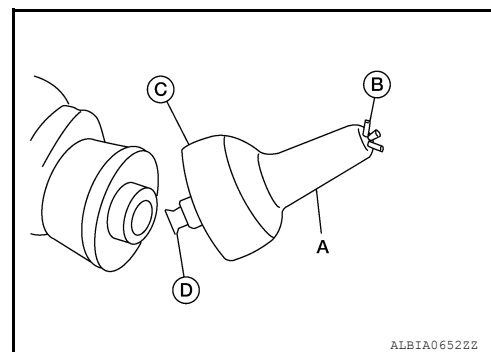

OIL SEAL

< REMOVAL AND INSTALLATION >

[VQ35DE]

- d. Apply sealant to rear oil seal retainer as shown.
Use Genuine Silicone RTV Sealant, or equivalent. Refer to GI-15, "Recommended Chemical Products and Sealants".
- Assembly should be completed within 5 minutes after coating.

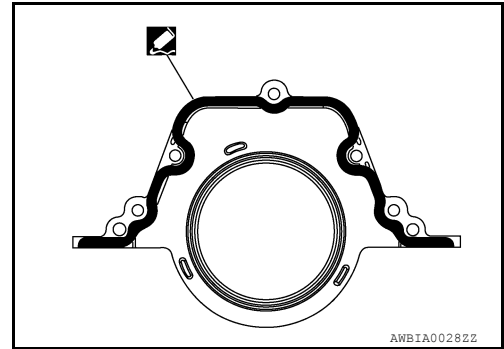

- e. Lubricate the sealing surface of the new rear main seal with new engine oil.
- f. Slide the new rear main seal (1) over the Tool (A) and onto the crankshaft.
- g. Loosen the wing nut and push the threaded rod into the handle to remove the Tool (A).
- h. Tighten the rear oil seal retainer bolts to specification.

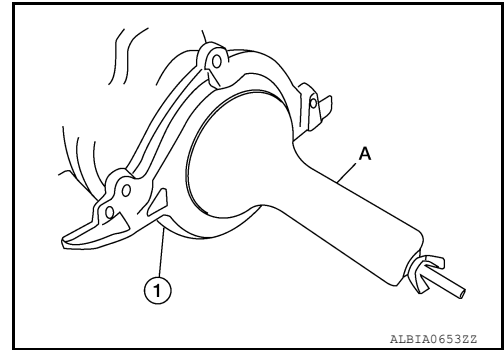

3. Installation of the remaining components is in the reverse order of removal.

CAUTION:

- When replacing an engine or transmission you must make sure the dowels are installed correctly during re-assembly.
- Improper alignment caused by missing dowels may cause vibration, oil leaks or breakage of drivetrain components.

CYLINDER HEAD

< REMOVAL AND INSTALLATION >

[VQ35DE]

CYLINDER HEAD

Removal and Installation

INFOID:000000007420306

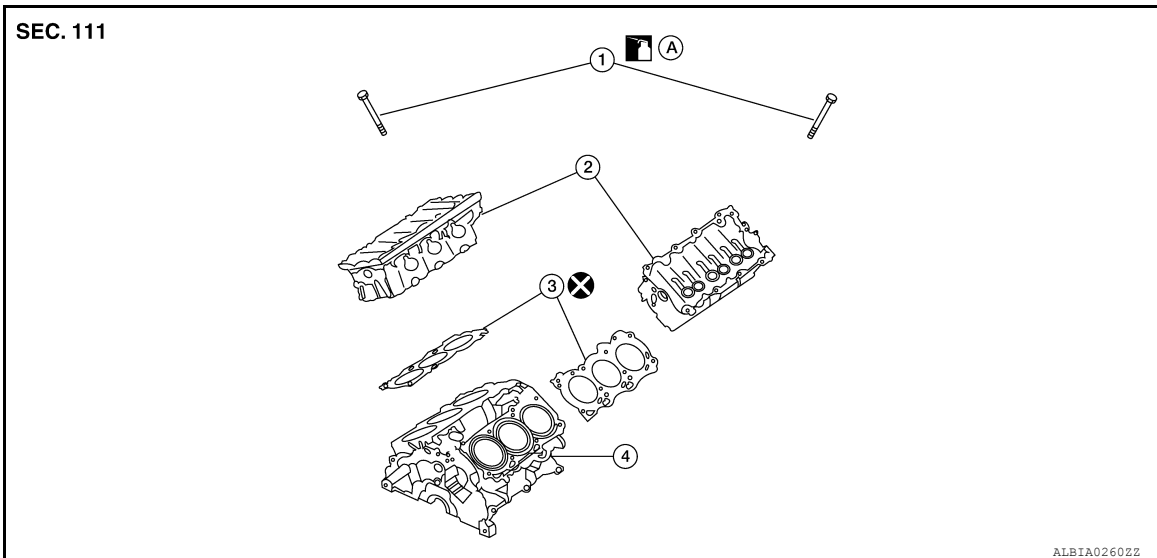

- | | | |
|-----------------------|----------------------------------|-------------------------|
| 1. Cylinder head bolt | 2. Cylinder head | 3. Cylinder head gasket |
| 4. Engine block | A. Follow installation procedure | |

REMOVAL

1. Remove the rear timing chain case. Refer to [EM-180, "Removal and Installation"](#).
2. Remove the intake manifold. Refer to [EM-136, "Removal and Installation"](#).
3. Remove the exhaust manifolds. Refer to [EX-14, "Removal and Installation"](#).
4. Remove the intake and exhaust camshafts. Refer to [EM-184, "Removal and Installation"](#).
5. Remove the coolant outlet housing. Refer to [CO-50, "Removal and Installation"](#).
6. Remove spark plugs. Refer to [EM-121, "Removal and Installation"](#).
7. Remove the RH and LH cylinder head bolts, with power tool.
 - The bolts should be loosened gradually in three stages.
 - Loosen the bolts in the numerical order as shown.

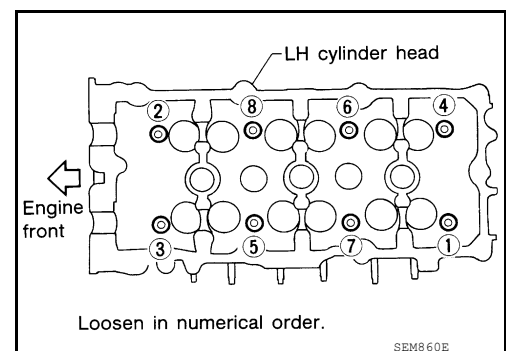
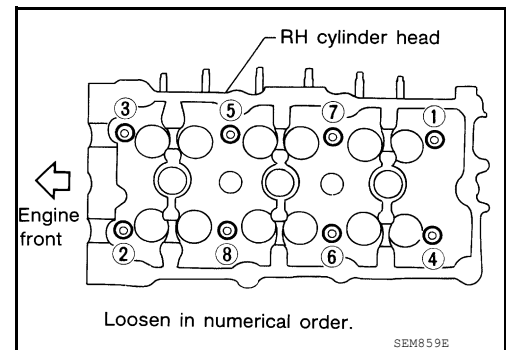

CYLINDER HEAD

< REMOVAL AND INSTALLATION >

[VQ35DE]

8. Remove cylinder heads and gaskets.
 - Discard the cylinder head gaskets and use new gaskets for installation.

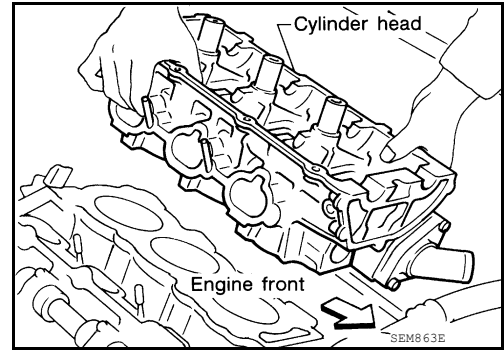

INSTALLATION

1. Turn the crankshaft until No. 1 piston is set at TDC on the compression stroke.
 - The crankshaft key should line up with the right bank cylinder center line as shown.

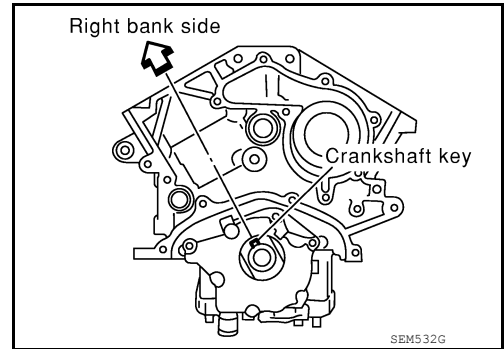

2. Install new gaskets on the cylinder heads.

CAUTION:

- Do not rotate crankshaft and camshaft separately or valves will strike piston heads.
- Do not reuse cylinder head gaskets.

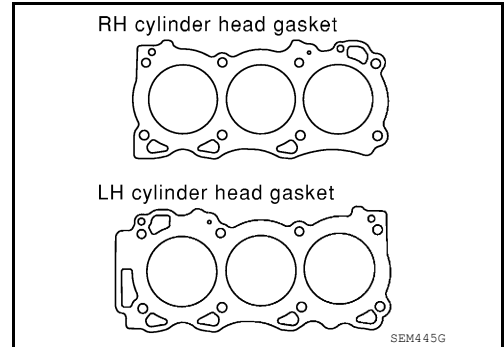

3. Inspect the cylinder head bolts before installing the cylinder heads.

CAUTION:

Cylinder head bolts are tightened by degree rotation tightening method. Whenever the size difference between d1 and d2 exceeds the limit, replace the bolts with new ones.

Limit (d1 - d2) : 0.11 mm (0.0043 in)

- Lubricate threads and seat surfaces of the bolts with new engine oil.

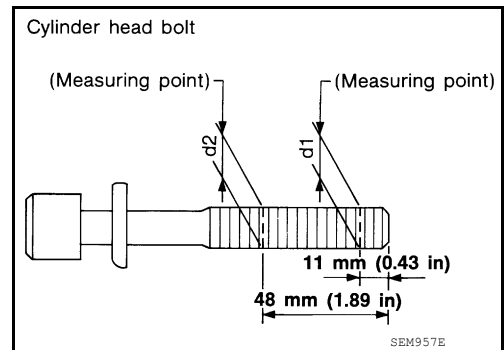

CYLINDER HEAD

< REMOVAL AND INSTALLATION >

[VQ35DE]

4. Install the cylinder heads on the cylinder block. Tighten the cylinder head bolts in the five steps in the numerical order as shown using Tool.

Tool Number : KV10112100 (BT-8653-A)

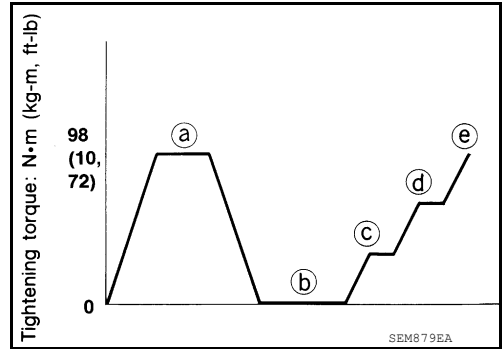

• Tightening procedure:

Cylinder head bolts

Step a : 98.1 N·m (10 kg-m, 72 ft-lb)

Step b : Loosen in the reverse order of tightening

Step c : 32.9 N·m (4.0 kg-m, 29 ft-lb)

Step d : 103° degrees rotation clockwise

Step e : 103° degrees rotation clockwise

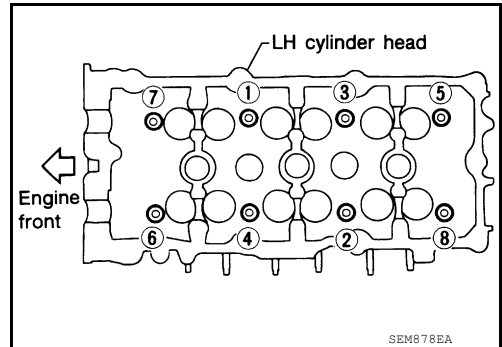
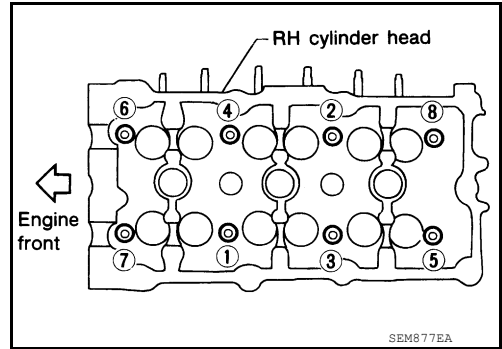

5. Installation of the remaining components is in the reverse order of removal.

CYLINDER HEAD

< REMOVAL AND INSTALLATION >

[VQ35DE]

Disassembly and Assembly

INFOID:000000007420307

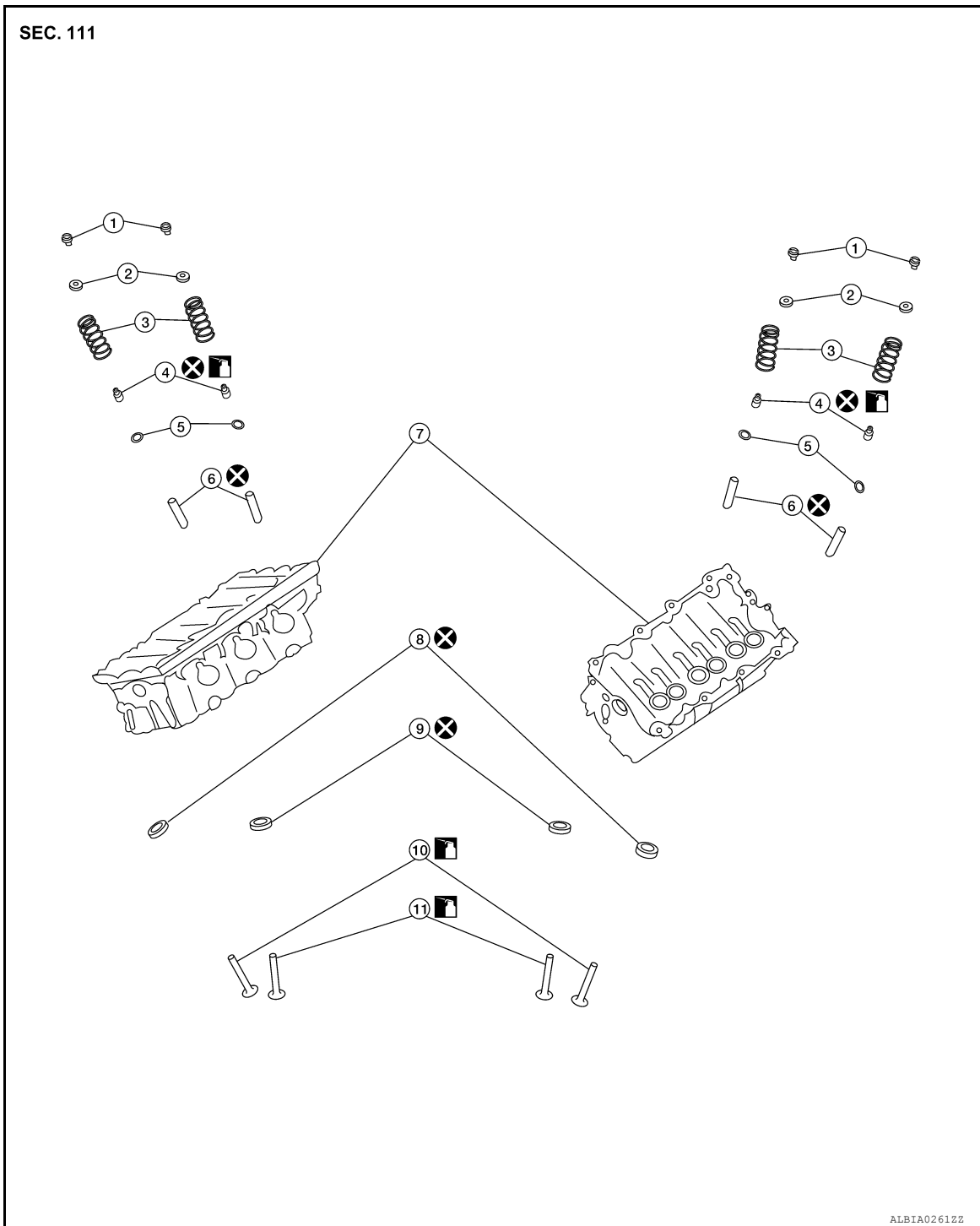

- | | | |
|-------------------|--------------------------|---------------------|
| 1. Valve collet | 2. Valve spring retainer | 3. Valve spring |
| 4. Valve oil seal | 5. Valve spring seat | 6. Valve guide |
| 7. Cylinder head | 8. Valve seat (EXH) | 9. Valve seat (INT) |
| 10. Valve (EXH) | 11. Valve (INT) | |

CAUTION:

- When installing camshafts, chain tensioners, oil seals, or other sliding parts, lubricate contacting surfaces with new engine oil.
- Apply new engine oil to threads and seat surface when installing cylinder head, camshaft sprocket, crankshaft pulley, and camshaft bracket.

CYLINDER HEAD

< REMOVAL AND INSTALLATION >

[VQ35DE]

- Attach tags to valve lifters so as not to mix them up.

DISASSEMBLY

1. Remove valve lifter.
 - Identify installation positions, and store them without mixing them up.
2. Remove valve collet.
 - Compress valve spring and remove valve collet with magnet hand using Tool.

CAUTION:

When working, take care not to damage valve lifter holes.

Tool numbers : KV10109230 (—)
: KV10116200 (J-26336-A)
: KV10115900 (J-26336-20)

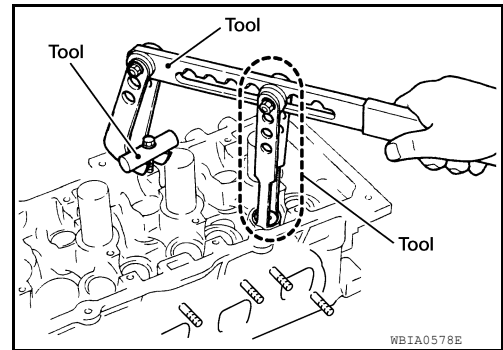

3. Remove valve spring retainer, valve spring and valve spring seat.
4. Push valve stem to combustion chamber side, and remove valve.
 - Identify installation positions, and store them without mixing them up.
5. Remove valve oil seals using Tool.

Tool number : KV10107902 (J-38959)

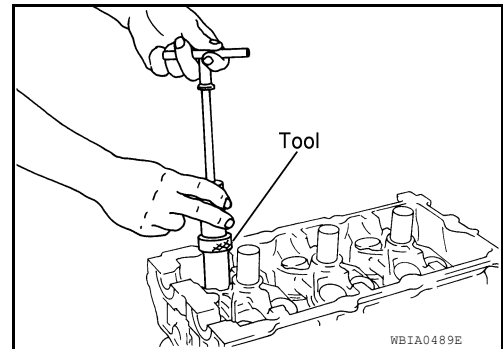

6. Determine if valve seat must be replaced, refer to [EM-202, "Inspection After Disassembly"](#).
7. Determine if valve guide must be replaced, refer to [EM-202, "Inspection After Disassembly"](#).
8. Remove spark plug tube, as necessary.
 - Using pair of pliers, pull spark plug tube out of cylinder head.

CAUTION:

 - Take care not to damage cylinder head.
 - Once removed, spark plug tube will be deformed and cannot be reused. Do not remove it unless absolutely necessary.

ASSEMBLY

1. If valve guide was removed, install it. Refer to [EM-202, "Inspection After Disassembly"](#).
2. If valve seat was removed, install it. Refer to [EM-202, "Inspection After Disassembly"](#).
3. Install valve oil seals using Tool.

Tool number : — (J-39386)

Height (H) (Without valve spring seat installed)

Intake and exhaust : 14.3 - 14.9 mm (0.563 - 0.587 in)

4. Install valve spring seat.
5. Install valves.
 - Install it in the original position.

NOTE:
Larger diameter valves are for intake side.

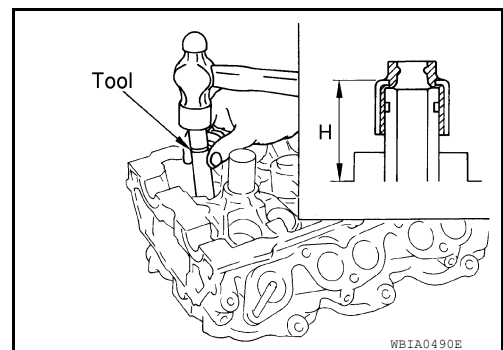

CYLINDER HEAD

[VQ35DE]

< REMOVAL AND INSTALLATION >

6. Install valve spring (uneven pitch type) with narrow pitch end (paint mark) to cylinder head side (valve spring seat side).

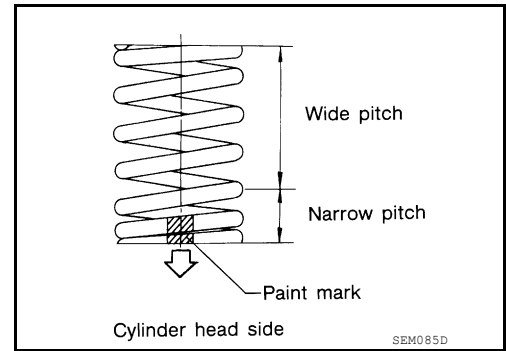

7. Install valve spring retainer.
8. Install valve collet.
• Compress valve spring with valve spring compressor, attachment and adapter using Tool. Install valve collet with magnet hand.
CAUTION:
When working, take care not to damage valve lifter holes.
• Tap valve stem edge lightly with plastic hammer after installation to check its installed condition.

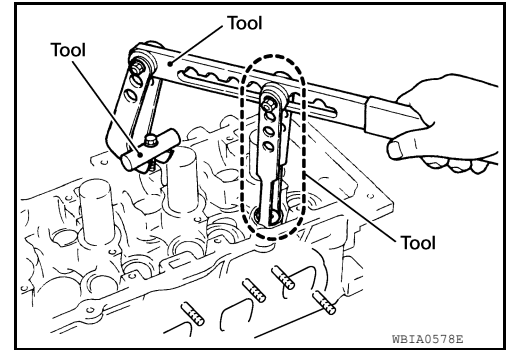

Tool numbers : KV10109230 (—)
: KV10116200 (J-26336-A)
: KV10115900 (J-26336-20)

9. Install valve lifter.
• Install it in the original position.
10. Install spark plug tube.
• Press-fit spark plug tube as follows:
a. Remove old liquid gasket adhering to cylinder head mounting hole.
b. Apply sealant to area within approximately 12 mm (0.47 in) from edge of spark plug tube press-fit side.
Use Genuine High Strength Locking Sealant or equivalent. Refer to [GI-15, "Recommended Chemical Products and Sealants"](#).
c. Press-fit spark plug tube so that its height (H) is as specified in using suitable drift.

Press-fit height (H) : 37.7 - 38.7 mm (1.484 - 1.529 in)

- CAUTION:**
• **When press-fitting, take care not to deform spark plug tube.**
• **After press-fitting, wipe off liquid gasket protruding onto cylinder-head upper face.**

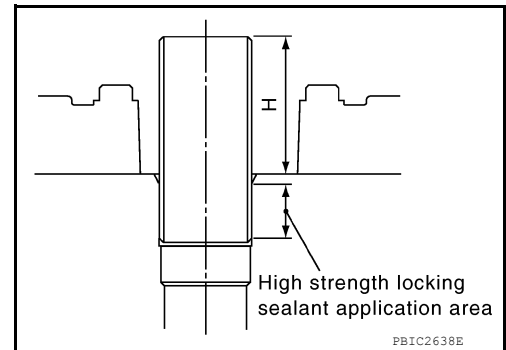

Inspection After Disassembly

INFOID:000000007420308

CYLINDER HEAD DISTORTION

Clean the surface of the cylinder head. Use a reliable straightedge and feeler gauge to check the flatness of cylinder head surface.

CYLINDER HEAD

< REMOVAL AND INSTALLATION >

[VQ35DE]

Check along six positions as shown.

Head surface distortion

Limit	: 0.1 mm (0.004 in)
Standard	: Less than 0.03 mm (0.0012 in)

If beyond the specified limit, resurface or replace it.

The limit for cylinder head resurfacing is determined by the cylinder block resurfacing.

Resurfacing Limit

Amount of cylinder head resurfacing is (A).	
Amount of cylinder block resurfacing is (B).	
The maximum limit	: $A + B = 0.2 \text{ mm (0.008 in)}$

After resurfacing cylinder head, check that camshaft rotates freely by hand. If resistance is felt, cylinder head must be replaced.

Nominal cylinder head height	: 126.3 - 126.5 mm (4.972 - 4.980 in)
------------------------------	---------------------------------------

VALVE GUIDE CLEARANCE

1. Measure valve deflection as shown. (Valve and valve guide mostly wear in this direction.)

Valve deflection limit (dial gauge reading)

Intake	: 0.24 mm (0.0094 in)
Exhaust	: 0.28 mm (0.0110 in)

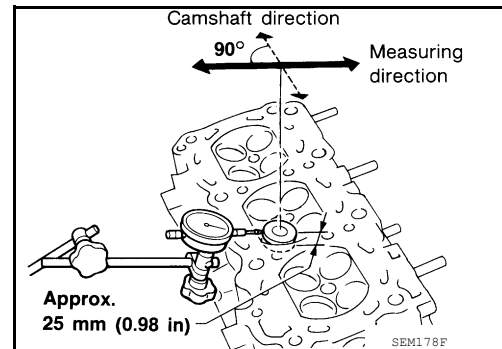

2. If it exceeds the limit, check valve to valve guide clearance.
 - a. Measure valve stem diameter and valve guide inner diameter. Refer to [EM-239, "Cylinder Head"](#).
 - b. Check that clearance is within specification.
(Valve guide clearance) = (Valve guide inner diameter) - (Valve stem diameter)

Valve to valve guide clearance standard

Intake	: 0.020 - 0.053 mm (0.0008 - 0.0021 in)
Exhaust	: 0.040 - 0.073 mm (0.0016 - 0.0029 in)

Valve to valve guide clearance limit

Intake	: 0.08 mm (0.0031 in)
Exhaust	: 0.1 mm (0.004 in)

- c. If it exceeds the limit, replace valve or valve guide.

VALVE GUIDE REPLACEMENT

When valve guide is removed, replace with oversized [0.2 mm (0.008 in)] valve guide.

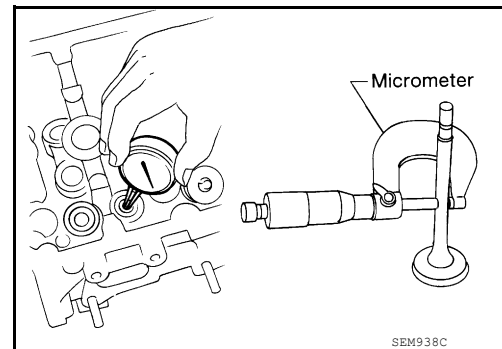

CYLINDER HEAD

< REMOVAL AND INSTALLATION >

[VQ35DE]

1. To remove valve guide, heat cylinder head to 110° to 130°C (230° to 266°F) by soaking in heated oil.

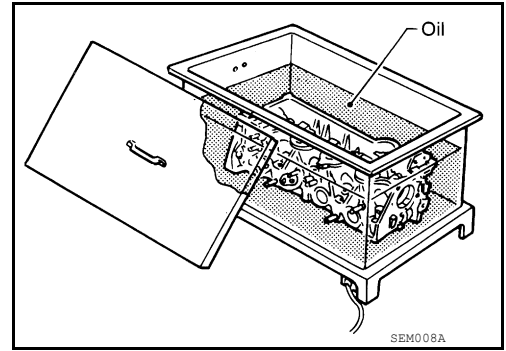

2. Drive out the valve guide with a press [under a 20 kN (2.2 US ton) pressure] or hammer and suitable tool.

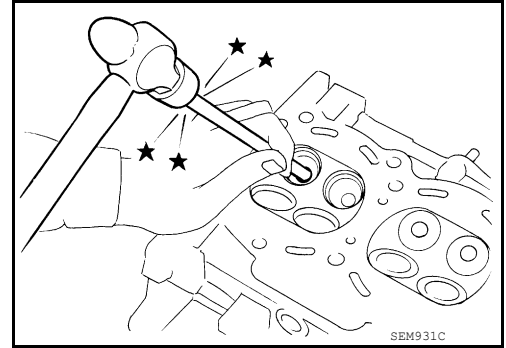

3. Ream cylinder head valve guide hole.

**Valve guide hole diameter : 10.175 - 10.196 mm
(for service parts), intake (0.4006 - 0.4014 in)
and exhaust**

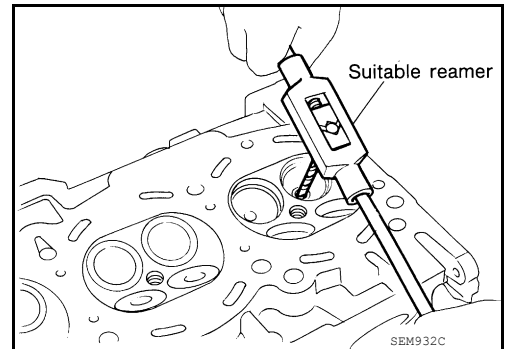

4. Heat cylinder head to 110° to 130°C (230° to 266°F) by soaking in heated oil and press new valve guide from camshaft side into the cylinder head to the dimensions as shown.

Projection (L) : 12.6 - 12.8 mm (0.496 - 0.504 in)

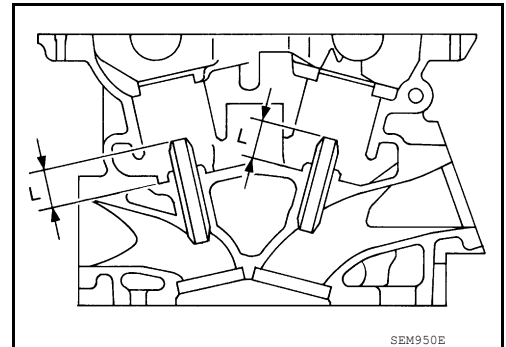

CYLINDER HEAD

< REMOVAL AND INSTALLATION >

[VQ35DE]

5. Using a valve guide reamer, apply a reamer finish to the valve guide.

Intake and exhaust finished size : 6.000 - 6.018 mm (0.2362 - 0.2369 in)

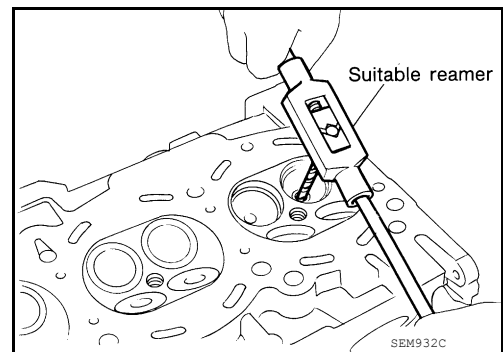

VALVE SEAT CONTACT

- After confirming that the dimensions of valve guides and valves are within specifications, perform this procedure.
- Apply prussian blue onto contacting surface of valve seat to check the condition of the valve contact on the surface.
- Check if the contact area band is continuous all around the circumference.
- If not, grind to adjust valve fitting and check again. If the contacting surface still has N.G conditions even after the re-check, replace valve seat.

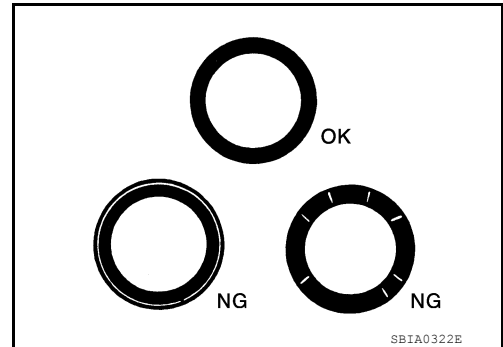

VALVE SEAT REPLACEMENT

1. Bore out old seat until it collapses. Boring should not continue beyond the bottom face of the seat recess in cylinder head. Set the machine depth stop to ensure this.
2. Ream cylinder head recess for service valve seat.

Oversize : 0.5 mm (0.020 in)
Intake : 38.500 - 38.516 mm (1.5157 - 1.5164 in)
Exhaust : 32.100 - 32.116 mm (1.2638 - 1.2644 in)

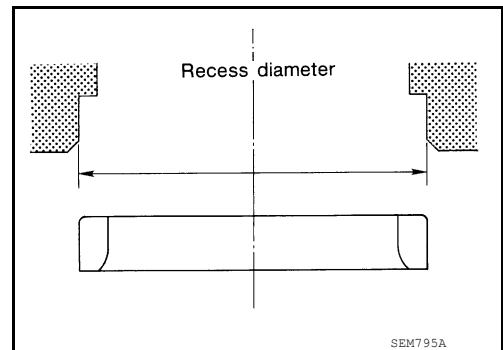

Be sure to ream in circles concentric to the valve guide center.

This will enable valve seat to fit correctly.

3. Heat cylinder head to 110° to 130°C (230° to 266°F) by soaking in heated oil.
4. Press fit valve seat until it seats on the bottom.
5. Cut or grind valve seat using suitable tool to the specified dimensions. Refer to [EM-239, "Cylinder Head"](#).
6. After cutting, lap valve seat with abrasive compound.
7. Check valve seating condition.

Seat face angle (α) : 45° - 45° degrees
Contacting width (W) for intake : 1.18 - 1.22 mm (0.0465 - 0.0480 in)
Contacting width (W) for exhaust : 1.38 - 1.42 mm (0.0543 - 0.0559 in)

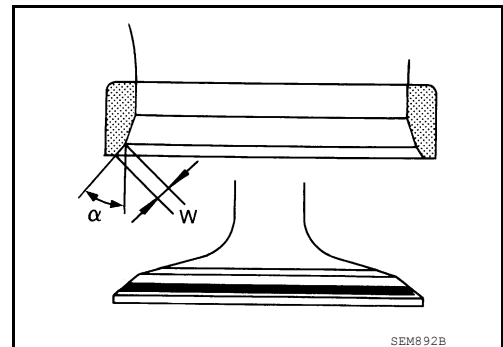

CYLINDER HEAD

< REMOVAL AND INSTALLATION >

[VQ35DE]

8. Use a depth gauge to measure the distance between the mounting surface of the cylinder head spring seat and the valve stem end. If the distance is shorter than specified, repeat step 5 to adjust it. If it is longer, replace the valve seat with a new one.

Valve seat resurface limit (L) intake	: 41.16 - 41.76 mm (1.6205 - 1.6441 in)
Valve seat resurface limit (L) exhaust	: 41.09 - 41.69 mm (1.6177 - 1.6413 in)

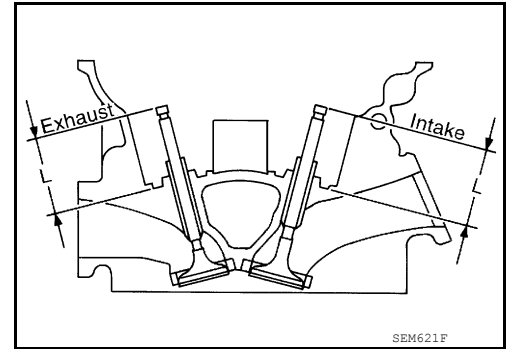

VALVE SPRING SQUARENESS

Set try square along the side of valve spring and rotate the spring. Measure the maximum clearance between the top face of spring and try square.

Out-of-square limit	: Less than 2.0 mm (0.079 in)
----------------------------	--------------------------------------

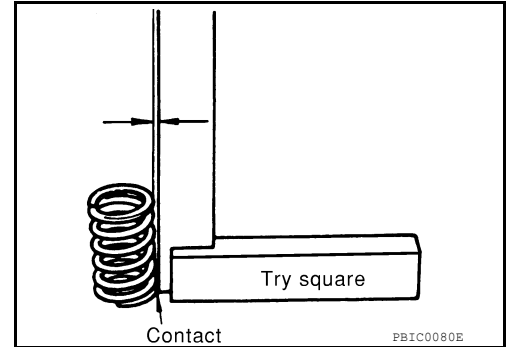

VALVE SPRING DIMENSIONS AND VALVE SPRING PRESSURE LOAD

Check valve spring pressure at specified spring height.

Installation height	: 166 - 188 N (16.9 - 19.2 kg, 37.3 - 42.3 lb) at height 37.0 mm (1.457 in)
Height during valve open	: 373 - 421 N (38.0 - 42.9 kg, 84 - 95 lb) at height 27.2 mm (1.071 in)

If it is not within specifications, replace the spring.

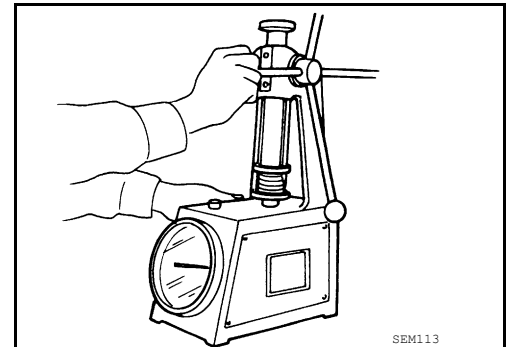

ENGINE MOUNT

ENGINE MOUNT (FRONT)

ENGINE MOUNT (FRONT) : Removal and Installation

INFOID:000000009316292

EM

WARNING:

- Situate the vehicle on a flat and solid surface.
- Place chocks at front and back of rear wheels.
- Always work safely.
- Do not start work until the engine and exhaust system are cooled completely.

CAUTION:

Do not damage or spill oil on the engine mount insulator (front).

NOTE:

When removing components such as hoses, tubes/lines, etc., cap or plug openings to prevent fluid from spilling.

REMOVAL

1. Remove the air cleaner assembly, front air duct and air duct hose and resonator assembly. Refer to [EM-132. "Removal and Installation"](#).
2. Remove the battery and battery tray assembly. Refer to [PG-68. "Removal and Installation \(Battery\)"](#) (coupe) and [PG-140. "Removal and Installation \(Battery\)"](#) (sedan).
3. Remove the fender protector side covers (RH/LH). Refer to [EXT-22. "Removal and Installation"](#) (coupe) and [EXT-46. "Removal and Installation"](#) (sedan).
4. Partially remove the fender protectors (RH/LH). Refer to [EXT-22. "Removal and Installation"](#) (coupe) and [EXT-46. "Removal and Installation"](#) (sedan).
5. Remove the radiator. Refer to [CO-39. "Removal and Installation"](#).
6. Remove the cooling fan shroud and motor assembly. Refer to [CO-41. "Removal and Installation"](#).
7. Remove the exhaust manifold heat shield (LH). Refer to [EM-141. "Removal and Installation \(RH\)"](#).
8. Support the engine (1) and transaxle (2) using a suitable jack (A) as shown.

CAUTION:

- Position a suitable jack under the engine and transaxle assembly as shown.
- Do not damage the front exhaust tube or transaxle oil pan with the jack.

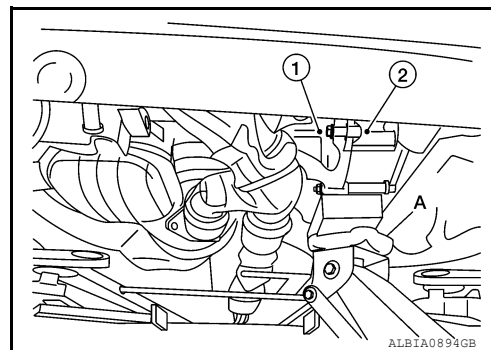

9. Disconnect the engine mount insulator (front) vacuum hose.
10. Remove the engine mount insulator (front) nut (A).

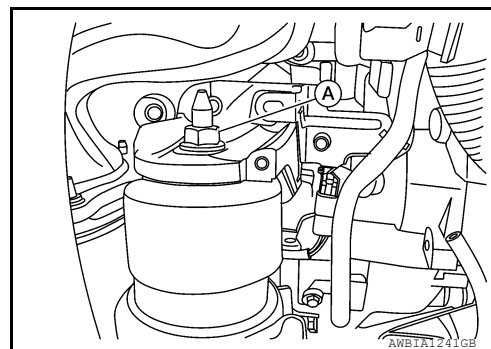

ENGINE MOUNT

[VQ35DE]

< REMOVAL AND INSTALLATION >

11. Loosen the engine bracket (front) bolts in the reverse order shown.

⇐ : Engine front

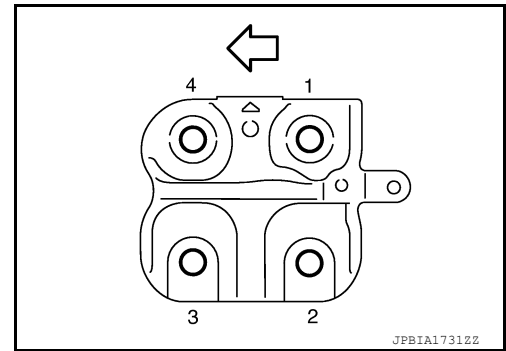

12. Remove the engine bracket (front).
13. Remove the engine mount insulator (front) bolts in the reverse order as shown.

⇐ :Front

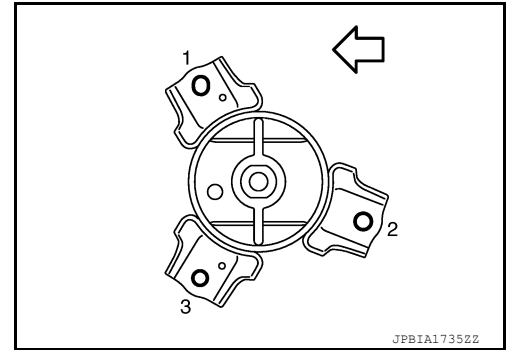

14. Remove the engine mount insulator (front).

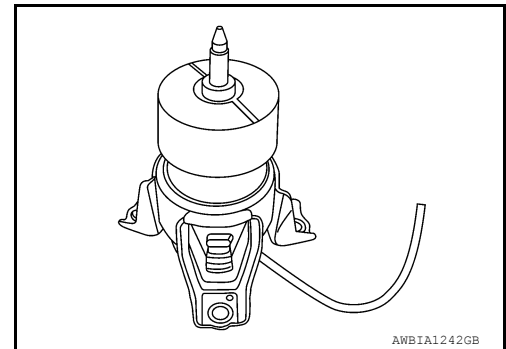

INSTALLATION

1. Install the engine mount insulator (front).

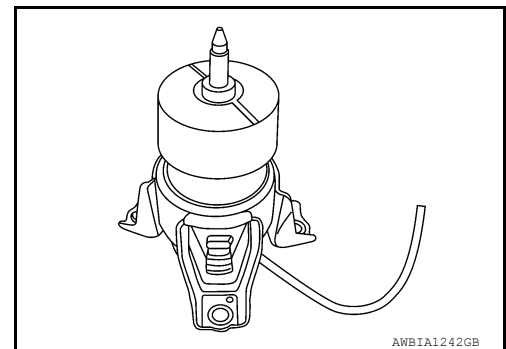

ENGINE MOUNT

[VQ35DE]

< REMOVAL AND INSTALLATION >

2. Install the engine mount insulator (front) bolts and tighten to specification in the order shown.

⇐ :Front

Engine mount insulator (front) bolts : 43 N·m (4.4 kg-m, 32 ft-lb)

CAUTION:

Check engine mount insulator (front) is seated properly before tightening.

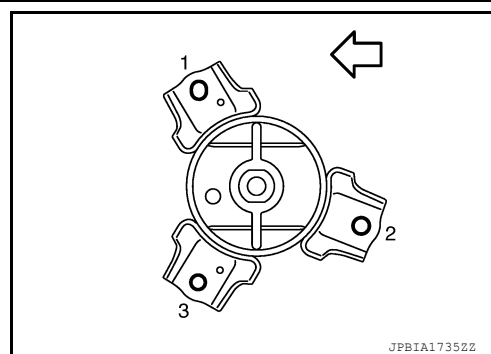

3. Install the engine mount bracket (front) to the engine block.
4. Tighten the engine mount bracket (front) bolts to specification in the order shown.

⇐ :Engine front

Engine bracket (front) bolts : 40 N·m (4.1 kg-m, 30 ft-lb)

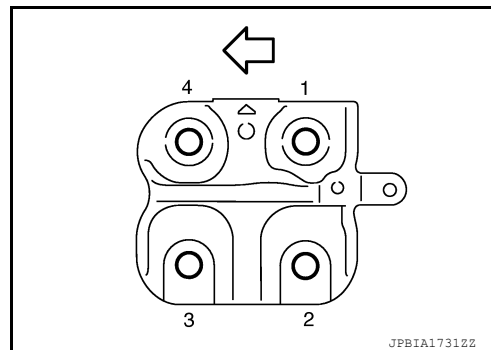

5. Install the engine mount insulator (front) nut (A) and tighten to specification.

Engine insulator (front) nut : 103 N·m (11 kg-m, 76 ft-lb)

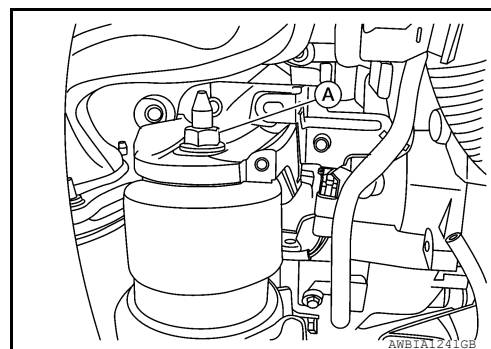

6. Installation of the remaining components is in the reverse order of removal.

ENGINE ASSEMBLY

< UNIT REMOVAL AND INSTALLATION >

[VQ35DE]

UNIT REMOVAL AND INSTALLATION

ENGINE ASSEMBLY

Removal and Installation

INFOID:000000007420309

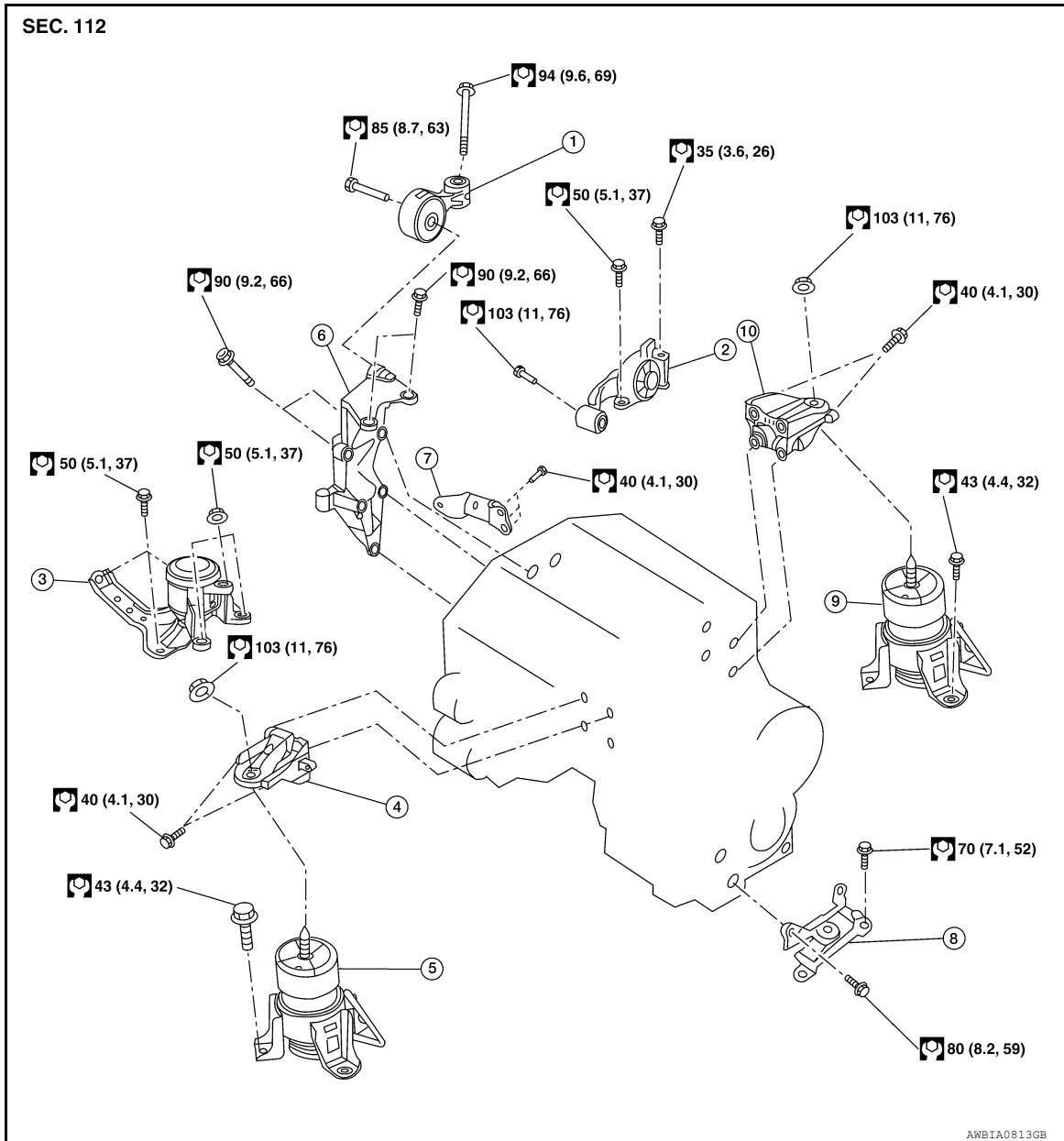

- | | | |
|-------------------------------|--|--------------------------------|
| 1. Torque rod | 2. Rear lower insulator and torque rod | 3. RH engine mount |
| 4. Front engine mount bracket | 5. Front engine mount insulator | 6. RH engine mount bracket |
| 7. Lower torque rod bracket | 8. LH transaxle mount | 9. Rear engine mount insulator |
| 10. Rear engine mount bracket | | |

WARNING:

- Place chocks at front and back of rear wheels.
- For engines not equipped with engine slingers, attach proper slingers and bolts as described in the NISSAN Parts Catalog.
- Do not start working until exhaust system and coolant are cool.

CAUTION:

ENGINE ASSEMBLY

< UNIT REMOVAL AND INSTALLATION >

[VQ35DE]

- If items or work required are not covered by the engine main body section, follow the applicable procedures.
- Use the correct supporting points for lifting and jacking. Refer to [GI-33, "Garage Jack and Safety Stand"](#).
- In removing the drive shafts, be careful not to damage any transaxle grease seals.
- Before separating the engine and transaxle, remove the crankshaft position sensor (POS).
- Do not damage the edge of the crankshaft position sensor (POS) or the ring gear teeth.

NOTE:

When removing components such as hoses, tubes/lines, etc., cap or plug openings to prevent fluid from spilling.

REMOVAL

1. Release fuel pressure. Refer to [EC-700, "Inspection"](#).
2. Drain engine coolant. Refer to [CO-36, "Changing Engine Coolant"](#).
3. Drain power steering fluid. Refer to [ST-8, "Draining"](#).
4. Remove front wheels and tires. Refer to [WT-68, "Adjustment"](#).
5. Remove fender protector side covers. Refer to [EXT-22, "Removal and Installation"](#) (Coupe models) or [EXT-46, "Removal and Installation"](#) (Sedan models).
6. Remove the engine undercover. Refer to [EXT-16, "Removal and Installation - Coupe"](#) (Coupe models) or [EXT-40, "Removal and Installation"](#) (Sedan models).
7. Remove the engine room cover.
8. Remove air intake duct and air cleaner case assembly with mass air flow sensor. Refer to [EM-132, "Removal and Installation"](#).
9. Remove battery and tray. Refer to [PG-69, "Removal and Installation \(Battery Tray\)"](#) (Coupe models) or [PG-141, "Removal and Installation \(Battery Tray\)"](#) (Sedan models).
10. Remove transmission control module. Refer to [TM-238, "Removal and Installation"](#).
11. Remove cowl top. Refer to [EXT-21, "Removal and Installation"](#) (Coupe models) or [EXT-45, "Removal and Installation"](#) (Sedan models).
12. Remove strut tower bar using power tools. Refer to [FSU-14, "Exploded View"](#).
13. Remove IPDM E/R. Refer to [PCS-45, "Removal and Installation"](#).
14. Remove the following parts:
 - EVAP vacuum hose
 - Brake booster vacuum hose
 - Heater hoses (engine side)
15. Disconnect CVT control cable.
16. Remove upper and lower radiator hoses.
17. Disconnect CVT fluid cooler hoses.
18. Remove power steering reservoir, suction hose and high pressure hose.
19. Disconnect fuel hose quick connection at vehicle piping side. Refer to [EM-152, "Removal and Installation"](#).
20. Remove the front exhaust tube using power tools. Refer to [EX-13, "Exploded View"](#).
21. Remove the cooling fan assembly. Refer to [CO-41, "Removal and Installation"](#).
22. Discharge and recover the R134a refrigerant. Refer to [HA-22, "HFC-134a \(R-134a\) Service Procedure"](#).
23. Disconnect the A/C high and low-pressure hoses from the compressor. Refer to [HA-32, "Removal and Installation for Compressor - VQ35DE Models"](#).

ENGINE ASSEMBLY

[VQ35DE]

< UNIT REMOVAL AND INSTALLATION >

24. Install engine slingers into front of LH cylinder head and rear of RH cylinder head.

- (A): RH cylinder head

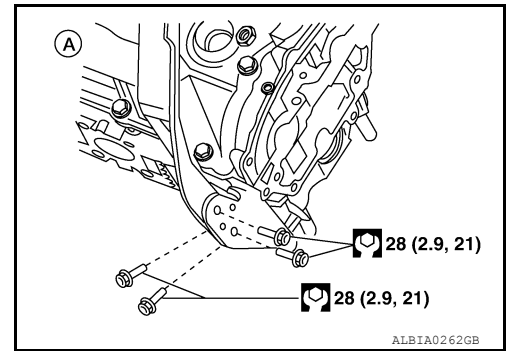

- (B): LH cylinder head

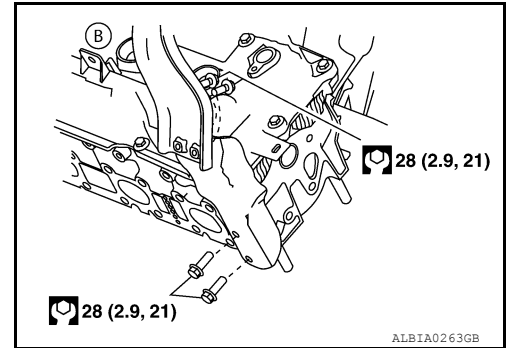

25. Remove rear access plate.
26. Remove the torque converter nuts.
27. Remove nuts of stabilizer connecting rods from struts. Refer to [FSU-14, "Exploded View"](#).
28. Remove front wheel speed sensors and position aside. Refer to [BRC-64, "Removal and Installation"](#) (ABS models), [BRC-136, "Removal and Installation"](#) (TCS/ABS models) or [BRC-253, "Removal and Installation"](#) (VDC/TCS/ABS models).
29. Remove front brake rotors. Refer to [BR-31, "BRAKE CALIPER ASSEMBLY : Removal and Installation"](#).
30. Remove strut bolts. Refer to [FSU-14, "Exploded View"](#).
31. Remove RH drive shaft center bearing bracket.
32. Remove lower steering column pinch bolt. Refer to [ST-14, "Exploded View"](#).
33. Disconnect power steering solenoid valve.
34. Disconnect front and rear engine mount insulator vacuum hoses.
35. Position Tool under suspension member and engine assembly.

Tool number : KV101J0010 (J-47242)

36. Disconnect the LH transaxle mount, torque rod and RH engine mount.
37. For additional safety, secure the engine in position with suitable tool.
38. Remove suspension member bolts. Refer to [FSU-14, "Exploded View"](#).
39. Carefully lower the engine, transaxle assembly and suspension member using Tool, avoiding interference with the vehicle body.

CAUTION:

- Before and during this procedure, always check if any harnesses are left connected.
- Avoid any damage to, or any oil/grease smearing or spills onto the engine mounting insulators.

Tool number : KV101J0010 (J-47242)

40. Remove the starter motor. Refer to [STR-56, "Removal and Installation"](#).
41. Remove the crankshaft position sensor (POS).

CAUTION:

- Avoid impacts such as a dropping.
- Do not disassemble.
- Keep it away from metal particles.

ENGINE ASSEMBLY

< UNIT REMOVAL AND INSTALLATION >

[VQ35DE]

- Do not place sensor close to magnetic materials.

42. Remove engine and transaxle harness.
43. Separate the engine and transaxle and mount the engine on Tool.

Tool number : ST0501S000 (—)

INSTALLATION

Installation is in the reverse order of removal.

NOTE:

Tighten transmission bolts to specification. Refer to [TM-247, "Removal and Installation"](#).

INSPECTION AFTER INSTALLATION

- Before starting engine, check oil/fluid levels including engine coolant and engine oil. If less than required quantity, fill to the specified level. Refer to [MA-12, "Fluids and Lubricants"](#).
- Use procedure below to check for fuel leakage.
- Turn ignition switch ON (with engine stopped). With fuel pressure applied to fuel piping, check for fuel leakage at connection points.
- Start engine. With engine speed increased, check again for fuel leakage at connection points.
- Run engine to check for unusual noise and vibration.

NOTE:

If hydraulic pressure inside timing chain tensioner drops after removal and installation, slack in the guide may generate a pounding noise during and just after engine start. However, this is normal. Noise will stop after hydraulic pressure rises.

- Warm up engine thoroughly to make sure there is no leakage of fuel, exhaust gas, or any oils/fluids including engine oil and engine coolant.
- Bleed air from passages in lines and hoses, such as in cooling system.
- After cooling down engine, again check oil/fluid levels including engine oil and engine coolant. Refill to specified level, if necessary.
- Summary of the inspection items:

Item		Before starting engine	Engine running	After engine stopped
Engine coolant		Level	Leakage	Level
Engine oil		Level	Leakage	Level
Transmission/ transaxle fluid	A/T and CVT Models	Leakage	Level/Leakage	Leakage
	M/T Models	Level/Leakage	Leakage	Level/Leakage
Other oils and fluids*		Level	Leakage	Level
Fuel		Leakage	Leakage	Leakage
Exhaust gas		—	Leakage	—

*Power steering fluid, brake fluid, etc.

CYLINDER BLOCK

< UNIT DISASSEMBLY AND ASSEMBLY >

[VQ35DE]

UNIT DISASSEMBLY AND ASSEMBLY

CYLINDER BLOCK

Disassembly and Assembly

INFOID:000000007420310

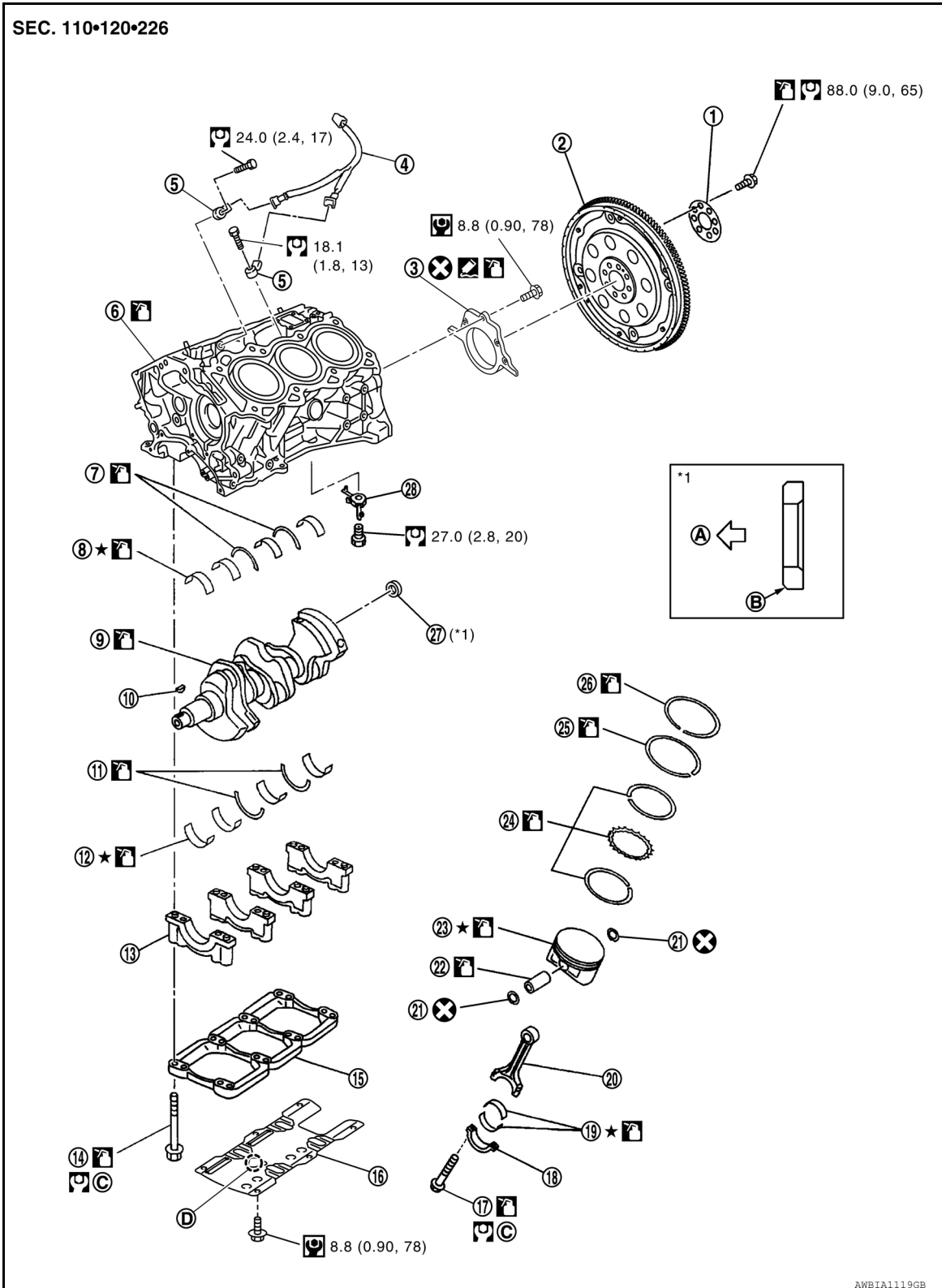

CYLINDER BLOCK

< UNIT DISASSEMBLY AND ASSEMBLY >

[VQ35DE]

- | | | | |
|----------------------------|--------------------------------------|----------------------------------|----|
| 1. Reinforcement plate | 2. Drive plate (CVT), Flywheel (M/T) | 3. Rear oil seal retainer | A |
| 4. Sub harness | 5. Knock sensor | 6. Cylinder block | |
| 7. Thrust bearing (upper) | 8. Main bearing (upper) | 9. Crankshaft | EM |
| 10. Crankshaft key | 11. Thrust bearing (lower) | 12. Main bearing (lower) | |
| 13. Main bearing cap | 14. Main bearing cap bolt | 15. Main bearing beam | C |
| 16. Baffle plate | 17. Connecting rod bolt | 18. Connecting rod bearing cap | |
| 19. Connecting rod bearing | 20. Connecting rod | 21. Snap ring | D |
| 22. Piston pin | 23. Piston | 24. Oil ring | |
| 25. Second ring | 26. Top ring | 27. Pilot converter | E |
| 28. Oil jet | | | |
| A. Crankshaft side | B. Chamfered | C. Follow the assembly procedure | F |
| D. Front mark | | | G |

CAUTION:

- Apply new engine oil to parts as marked in illustrations before installation.
- Place removed parts such as bearings and bearing caps in their proper order and direction.
- When installing the connecting rod nuts, and main bearing cap bolts, apply new engine oil to the threads and mating surfaces
- Do not allow any magnetic materials to contact the signal plate teeth on the drive plate.

DISASSEMBLY

1. Remove the engine assembly. Refer to [EM-210](#).
2. Remove drive plate.
 - Loosen bolts in diagonal order.

CAUTION:

- Do not disassemble drive plate.
- Do not place the drive plate with signal plate facing down.
- When handling signal plate, take care not to damage or scratch it.
- Handle signal plate in a manner that prevents it from becoming magnetized.

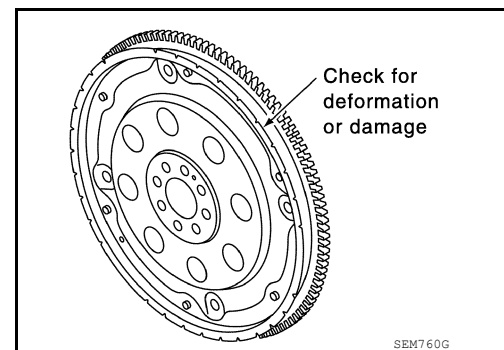

3. Remove pilot converter using Tool.

Tool number : **ST16610001 (J-23907)**

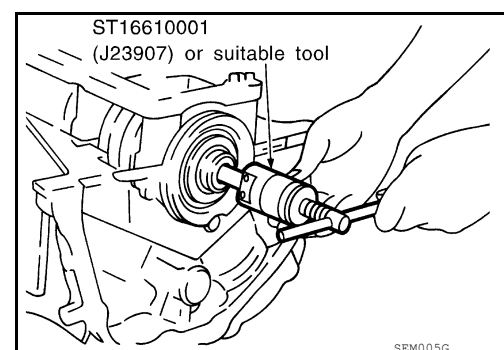

4. Install the engine on the engine stand.
5. Remove the knock sensors.
 - **CAUTION:**
Carefully handle sensors avoiding shocking it.
6. Drain the engine of all coolant and oil.
7. Remove the oil pan. Refer to [EM-145, "Removal and Installation \(Upper Oil Pan\)"](#).
8. Remove the timing chain. Refer to [EM-171, "Removal"](#).
9. Remove the cylinder head. Refer to [EM-197, "Removal and Installation"](#).

CYLINDER BLOCK

< UNIT DISASSEMBLY AND ASSEMBLY >

[VQ35DE]

10. Cut away liquid gasket and remove rear oil seal retainer using Tool. Refer to [EM-113, "Precaution for Liquid Gasket"](#).

Tool number : KV10111100 (J-37228)

CAUTION:

- Be careful not to damage mounting surface.
- If rear oil seal retainer is removed, replace it with a new one.

NOTE:

Rear oil seal and retainer form a single part and are handled as an assembly.

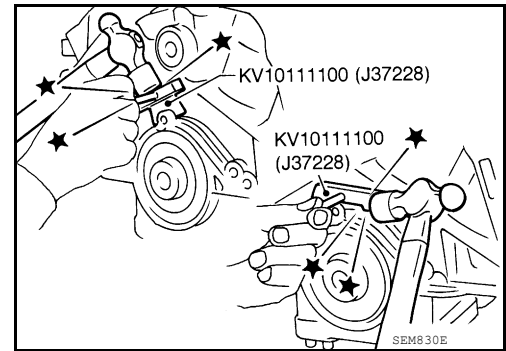

11. Remove the piston and connecting rod assemblies.
- a. Position the crankshaft pin corresponding to the connecting rod to be removed onto the bottom dead center.
 - b. Remove the connecting rod cap.
 - c. Using a hammer handle or similar tool, push the piston and connecting rod assembly out to the cylinder head side.
 - Before removing the piston and connecting rod assembly, check the connecting rod side clearance. Refer to [EM-243, "Cylinder Block"](#).

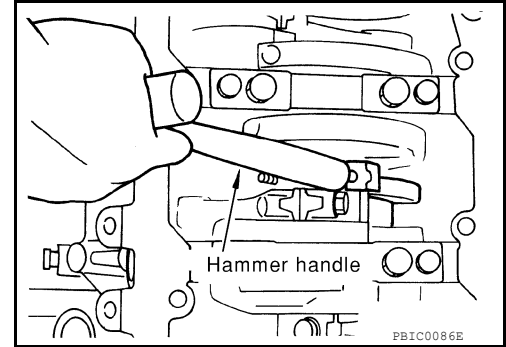

12. Remove the connecting rod bearings.

CAUTION:

- When removing the connecting rod side bearings, note the installation position. Keep them in the correct order.

13. Remove the piston rings from the piston.
- Before removing the piston rings, check the piston ring side clearance. Refer to [EM-225, "Inspection"](#).
 - Use a piston ring expander.

CAUTION:

- When removing the piston rings, be careful not to damage the piston. Do not expand the rings excessively.
- Be careful to mark the rings if they are to be reused so they are installed in their original position.

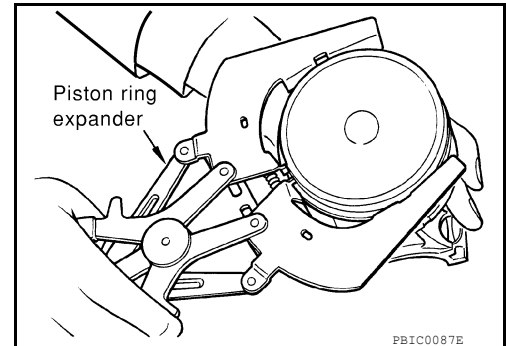

14. Remove the piston from the connecting rod as follows.

- a. Using a snap ring pliers, remove the snap ring.

CAUTION:

Do not reuse snap rings, always replace with new ones.

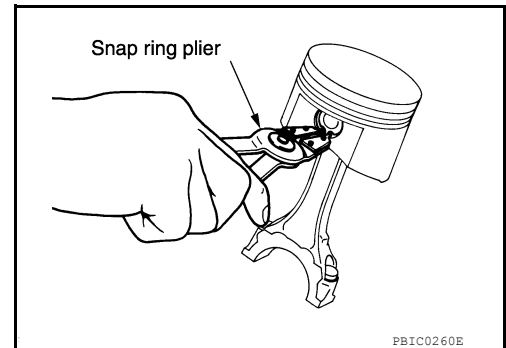

CYLINDER BLOCK

< UNIT DISASSEMBLY AND ASSEMBLY >

[VQ35DE]

- b. Heat the pistons to 60° - 70°C (140° - 158°F).

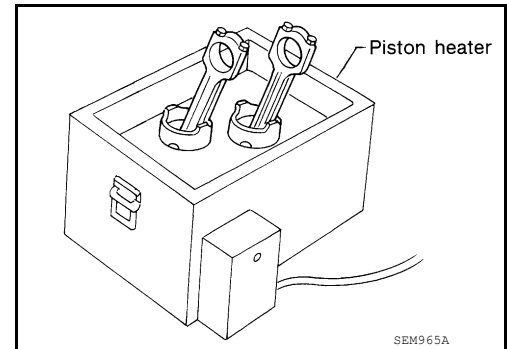

- c. Push out the piston pin with a suitable tool, with an outer diameter approximately 20 mm (0.8 in).

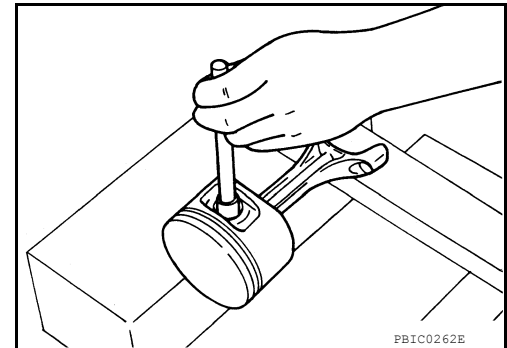

15. Remove the rear oil seal retainer from the cylinder block.
- Insert a screwdriver or similar tool between the rear end of the crankshaft counter weight and rear oil seal retainer, and separate the liquid gasket to remove.

CAUTION:

Be careful not to damage the mating surface.

NOTE:

When replacing the rear oil seal during on-vehicle service, it is necessary to remove the oil pan. Refer to [EM-145, "Removal and Installation \(Upper Oil Pan\)"](#).

16. Remove the baffle plate from the main bearing beam.
17. Loosen the bolts in the numerical order as shown and remove the main bearing beam, bearing caps and crankshaft.
- Before loosening the main bearing cap bolts, measure the crankshaft side clearance. Refer to [EM-225, "Inspection"](#).

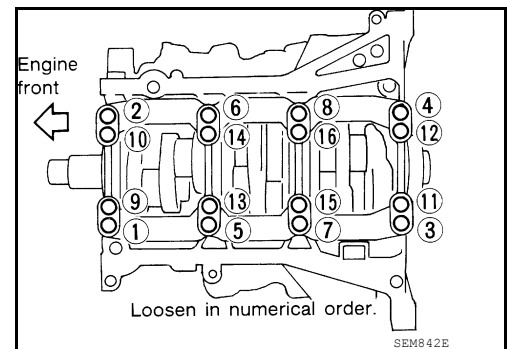

18. Remove the oil jets and dowel pins.
19. Remove the main bearings and thrust bearings from the cylinder block and main bearing caps.
- When removing them, note the direction and position. Keep them in the correct order for installation.

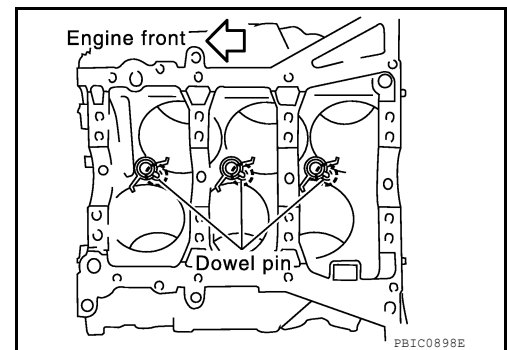

ASSEMBLY

CYLINDER BLOCK

[VQ35DE]

< UNIT DISASSEMBLY AND ASSEMBLY >

1. Blow out the coolant and oil passages and cylinder bore to remove any foreign materials.

WARNING:

Use goggles to protect your eyes.

2. Install each plug to cylinder block as shown.

(B) : Water drain plug

- Apply sealant to the thread of water drain plug (A).
Use Anaerobic Liquid Gasket or equivalent. Refer to GI-15, "Recommended Chemical Products and Sealants".
- Apply sealant to the thread of connector bolt (D).
Use Genuine RTV Silicone Sealant or equivalent. Refer to GI-15, "Recommended Chemical Products and Sealants".
- Apply sealant to the thread of plug (C).
Use genuine high strength thread locking sealant or equivalent. Refer to GI-15, "Recommended Chemical Products and Sealants".
- Replace washers with new one.

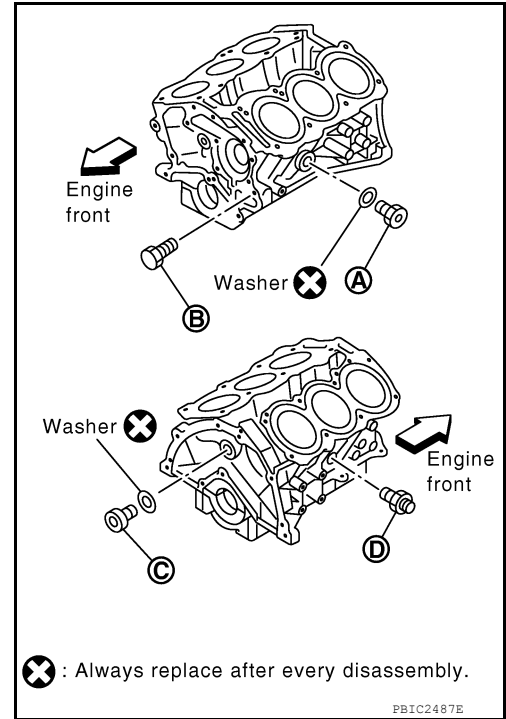

• Tighten each plug and connector bolt as specified below.

Part	Washer	Tightening torque
(A)	Yes	62.0 N·m (6.3 kg-m, 46 ft-lb)
(B)	No	9.8 N·m (1.0 kg-m, 87 in-lb)
(C)	Yes	62.0 N·m (6.3 kg-m, 46 ft-lb)
(D)	No	19.6 N·m (2.0 kg-m, 14 ft-lb)

3. Install the oil jets.

- Insert the oil jet dowel pin into the cylinder block dowel pin hole, and tighten the bolts.

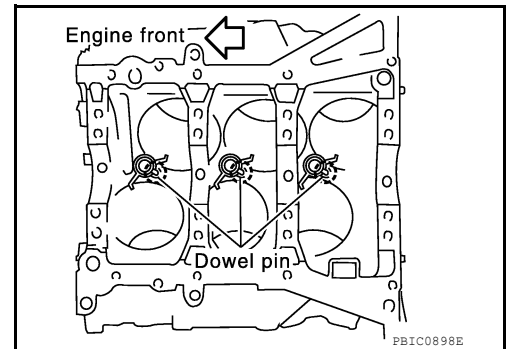

CYLINDER BLOCK

[VQ35DE]

< UNIT DISASSEMBLY AND ASSEMBLY >

4. Install the main bearings and the thrust bearings.
 - a. Remove dust, dirt, and oil on the bearing mating surfaces of the cylinder block and the main bearing cap.
 - b. Install the thrust bearings to both sides of the No. 3 journal housing on the cylinder block and the main bearing cap.
 - Install the thrust bearings with the oil groove facing the crankshaft arm (outside).
 - Install bearing with a projection on one end on cylinder block and bearing with a projection at center on cap. Align each projection with mating notch.

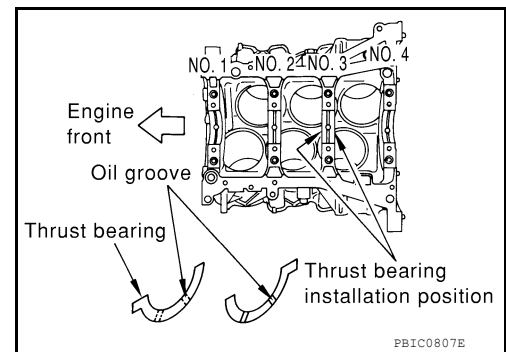

5. Set the upper main bearings in their proper positions on the cylinder block.
 - Confirm the correct main bearings are used. Refer to [EM-225, "Inspection"](#).

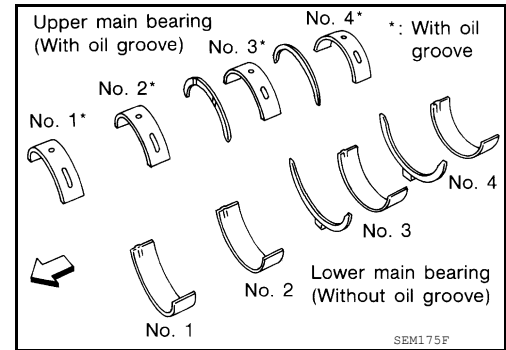

6. Instructions for the re-use of the main bearing cap bolts.
 - A plastic zone tightening method is used for tightening the main bearing cap bolts. Measure d_1 and d_2 as shown.
 - For d_2 , select the minimum diameter in the measuring area.
 - If the difference between d_1 and d_2 exceeds the limit, replace the bolts for assembly.

Limit ($d_1 - d_2$) : 0.11 mm (0.0043 in)

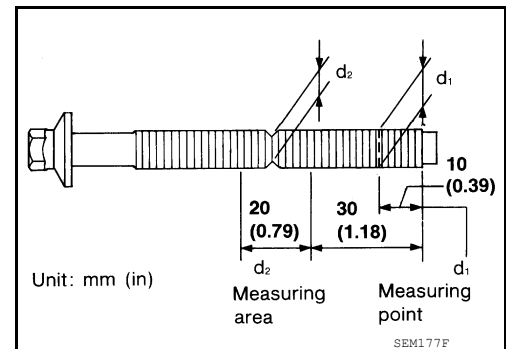

7. After installing the crankshaft, lower main bearings, main bearing caps, main bearing beam, and bearing cap bolts. Tighten the bearing cap bolts in the numerical order as shown.

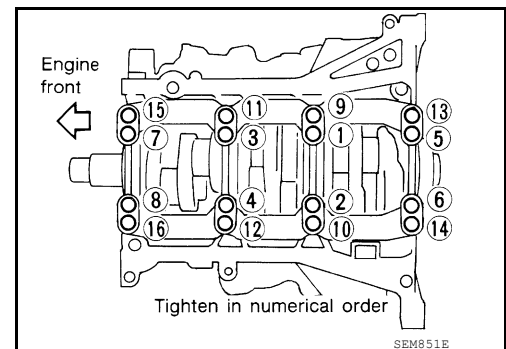

CYLINDER BLOCK

[VQ35DE]

< UNIT DISASSEMBLY AND ASSEMBLY >

- Make sure that the front marks on the main bearing beam faces the front of the engine.
- Prior to tightening all the bearing cap bolts, place the bearing beam in its proper position by shifting the crankshaft in the axial position.
- After tightening the bearing cap bolts, make sure the crankshaft turns smoothly.
- Lubricate the threads and seat surfaces of the bolts with new engine oil.
- Tighten the bolts in two stages:

CAUTION:

Measure the tighten angle in stage 2 using Tool. Do not measure visually.

Stage 1 : 32 - 38 N·m (3.3 - 3.9 kg-m, 24 - 28 ft-lb)

Stage 2 : 90° - 95° degrees clockwise

Tool number : KV10112100 (BT-8653-A)

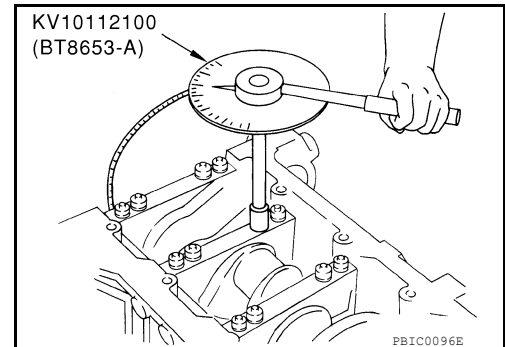
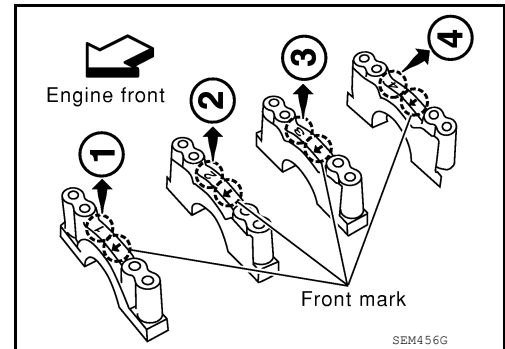

- Measure crankshaft end play.
 - If beyond the limit, replace the bearing with a new one.

Standard : 0.10 - 0.25 mm (0.0039 - 0.0098 in)

Limit : 0.30 mm (0.0118 in)

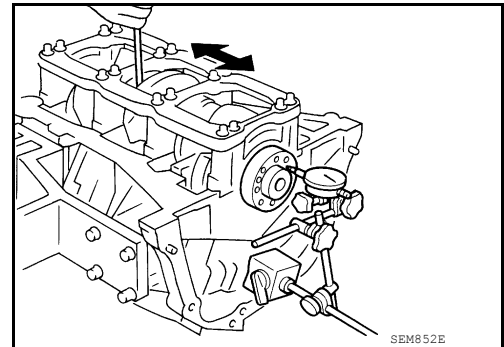

- Install the rear oil seal retainer using Tool (A).

Tool number : — (J-47128)

- Loosen the wing nut (B) on the end of the Tool (A).
- Insert the arbor (D) into the crankshaft pilot hole until the outer lip (C) of the Tool (A) covers the edge of the crankshaft sealing surface.
- Tighten the wing nut (B) to secure the Tool (A) to the crankshaft.

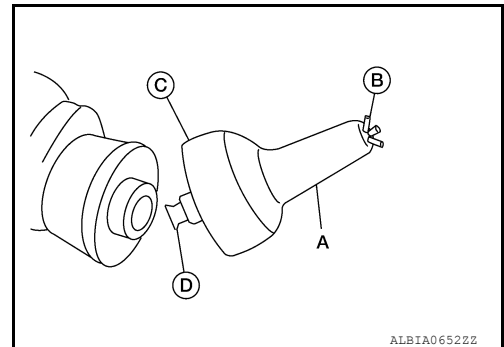

CYLINDER BLOCK

< UNIT DISASSEMBLY AND ASSEMBLY >

[VQ35DE]

- d. Apply sealant to rear oil seal retainer as shown.
Use Genuine Silicone RTV Sealant, or equivalent. Refer to [GI-15, "Recommended Chemical Products and Sealants"](#).
- Assembly should be completed within 5 minutes after coating.
- CAUTION:**
The components must be installed within 5 minutes of the liquid gasket application. Then allow 30 minutes for the liquid gasket to set before operating the engine.

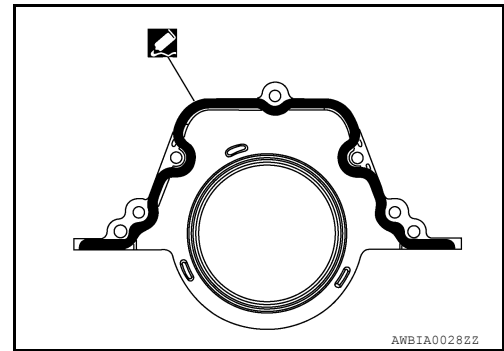

- e. Lubricate the sealing surface of the new rear main seal with new engine oil.
f. Slide the new rear main seal (1) over the Tool (A) and onto the crankshaft.
g. Loosen the wing nut and push the threaded rod into the handle to remove the Tool (A).
h. Tighten the rear oil seal retainer bolts to specification.

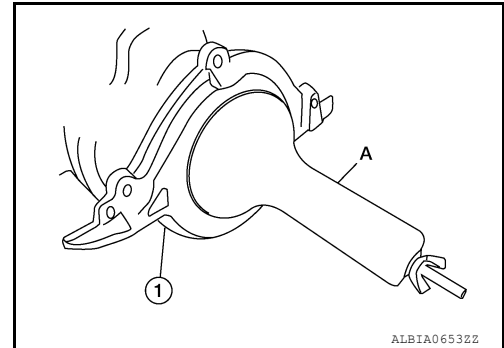

10. Install the piston to the connecting rod.
- a. Using suitable snap ring pliers, install the snap ring fully into the pin-groove of the piston rear side.
- Piston front mark (A)
 - Oil hole (B)
 - Connecting rod front mark (C)
 - Cylinder No. (D)

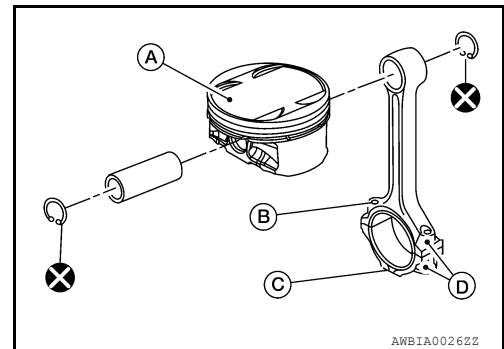

- b. Install the piston to the connecting rod.
- Heat the piston until the piston pin can be pushed in by hand without excess force [approx. 60° - 70°C (140° to 158°F)]. From the front to the rear, insert the piston pin into the piston and through the connecting rod.

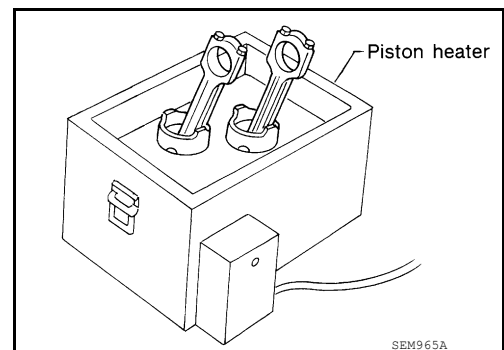

CYLINDER BLOCK

[VQ35DE]

< UNIT DISASSEMBLY AND ASSEMBLY >

- Assemble so that the piston front mark (B) on the crown and the oil hole (C), connecting rod front mark (D) and Cylinder No. (E) on the are positioned as shown.

- ⇐: Front
- Piston grade number (A)
- Pin grade number (F)

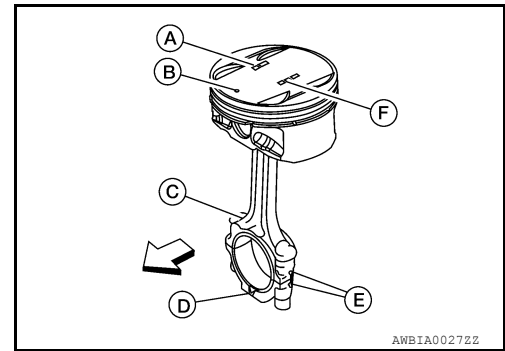

- c. Install the snap ring into the front of the piston pin-groove.
- After installing, check that the connecting rod pivots smoothly on the pin.

CAUTION:

Do not reuse snap rings, always replace with new ones.

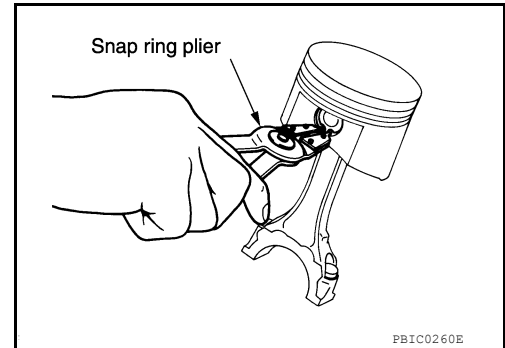

11. Using a piston ring expander, install the piston rings.

CAUTION:

- Be careful not to damage the piston.
- When the piston rings are not replaced, remount the rings in their original positions.
- When replacing the piston rings, those without stamped surface (A) can be mounted either side up.
- Install the second ring with the stamped surface (B) facing upward. If the ring is not stamped it can face in either direction.

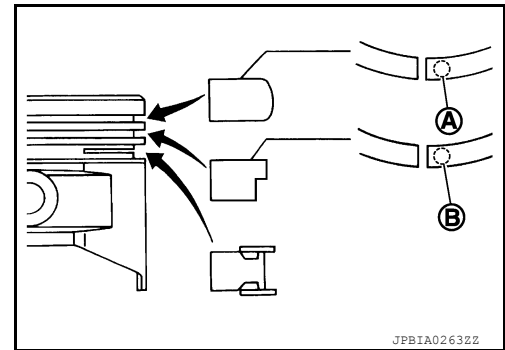

Top ring (A) : —

Second ring (B) : 2A

- Position each ring with the gap as shown, referring to the piston front mark.

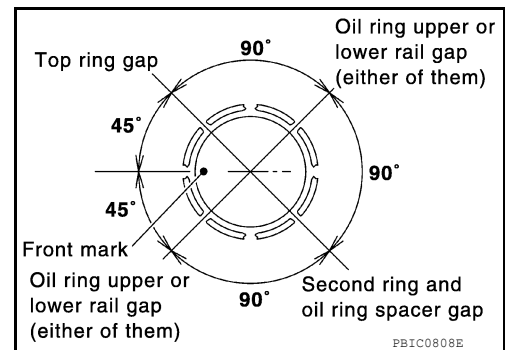

CYLINDER BLOCK

< UNIT DISASSEMBLY AND ASSEMBLY >

[VQ35DE]

12. Install the connecting rod bearings to the connecting rod and the connecting rod cap.
- When installing the connecting rod bearings, apply engine oil to the bearing surface (crankshaft side). Do not apply oil to the back surface (connecting rod and cap side), but thoroughly clean it.
 - When installing, align the connecting rod bearing protrusion with the notch of the connecting rod to install.
 - Check that the oil holes on the connecting rod and on the corresponding bearing are aligned.

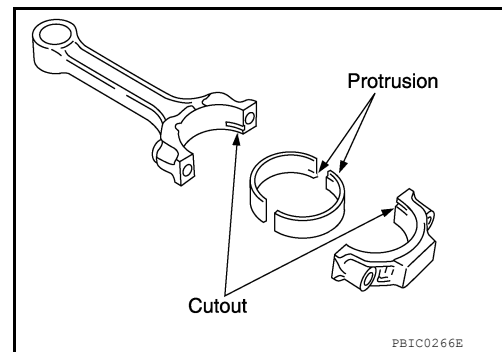

13. Install the piston and connecting rod assembly into the corresponding cylinder.
- Position the crankshaft pin corresponding to the connecting rod to be installed onto the bottom dead center.
 - Apply engine oil sufficiently to the cylinder bore, piston, and crankshaft pin.
 - Match the cylinder position with the cylinder No. (B) on the connecting rod to install.
 - Install the piston with the piston front mark (A) on the crown facing the front of the engine (↔), using a suitable tool.
 - Oil hole (C)

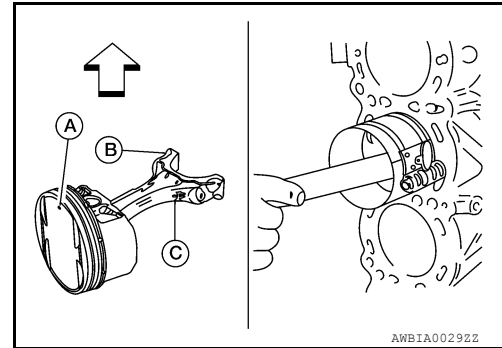

CAUTION:

Be careful not to damage the crankshaft pin and cylinder wall, resulting from an interference of the connecting rod big end.

14. Install the connecting rod cap.
- Match the stamped cylinder number marks on the connecting rod with those on the cylinder cap for installation.
 - Install the piston connecting rod assembly and cap so that the front mark on the cap and piston are facing the front of the engine.
 - **Lubricate the threads and seat surfaces with new engine oil.**

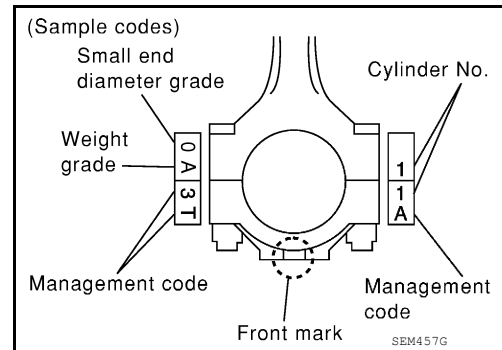

15. Check the connecting rod cap bolts before reusing, then install in their original position in the connecting rod. The bolts should screw in smoothly by hand.
- Measure the outer diameter of the connecting rod cap bolt as shown.

Outer diameter (d) of the connecting rod bolt
Standard : 7.90 - 8.00 mm (0.3110 - 0.3150 in)
Limit : 7.75 mm (0.3051 in)

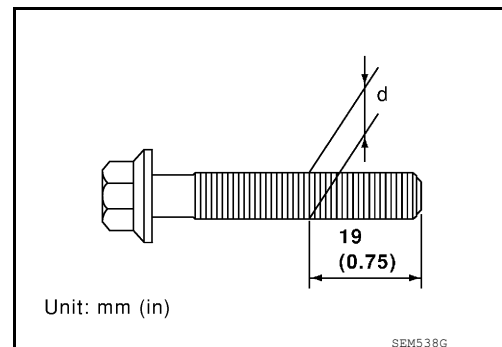

16. Tighten the connecting rod nuts in two stages using Tool:

CYLINDER BLOCK

< UNIT DISASSEMBLY AND ASSEMBLY >

[VQ35DE]

Stage 1 : 19 - 21 N·m (1.9 - 2.1 kg·m, 14 - 15 ft·lb)

Stage 2 : 90° - 95° degrees clockwise

CAUTION:

Always use either an angle wrench or protractor. Avoid tightening based on visual check alone.

Tool number : KV10112100 (BT-8653-A)

- Apply engine oil to the threads and seats of the connecting rod bolts and nuts.
- After tightening the nuts, make sure that the crankshaft rotates smoothly.
- Check the connecting rod side clearance. If beyond the limit, replace the connecting rod and/or crankshaft.

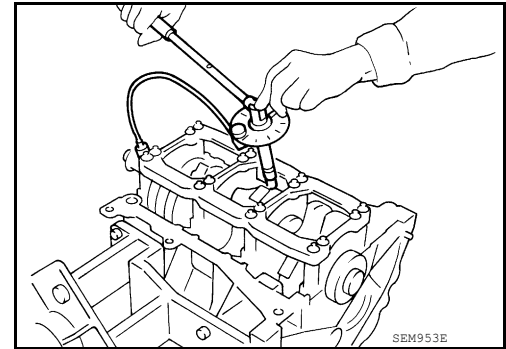

Connecting rod side clearance:

Standard : 0.20 - 0.35 mm (0.0079 - 0.0138 in)

Limit : 0.40 mm (0.0157 in)

17. Install the baffle plate to the main bearing beam.
18. Install the knock sensor.
 - Make sure that there is no foreign material on the cylinder block mating surface and the back surface of the knock sensor.
 - Install the knock sensor with the connector facing the rear of the engine.
 - Do not tighten the bolts while holding the connector.
 - Make sure that the knock sensor does not interfere with other parts.

CAUTION:

If any impact by dropping occurs to the knock sensor, replace it with new one.

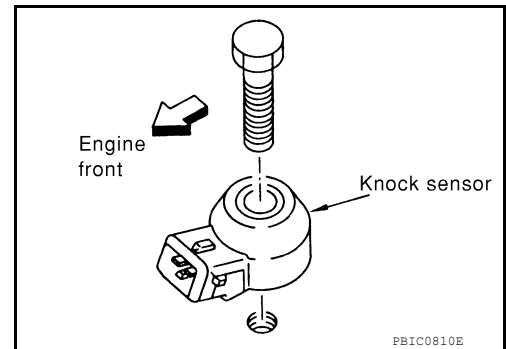

19. Press-fit pilot converter with its chamfer facing crankshaft as shown in the figure.

← : Crankshaft side

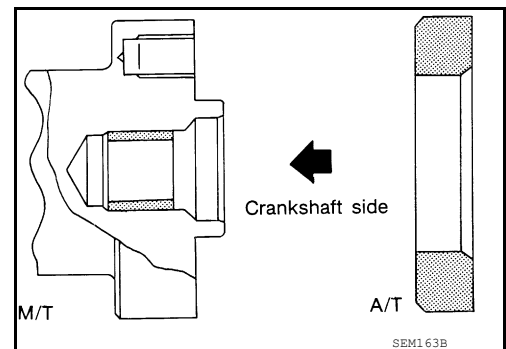

20. Install the drive plate.
 - Install the drive plate and reinforce plate in the direction as shown.
 - Align dowel pins of crankshaft rear and drive plate with pin holes of each part.
 - Secure the crankshaft using a ring gear stopper.
 - Tighten the drive plate bolts in one or two steps.

21. Install the cylinder head. Refer to [EM-197, "Removal and Installation"](#).

22. Install the timing chain. Refer to [EM-174, "Installation"](#).

23. Install the oil pan. Refer to [EM-145, "Removal and Installation \(Upper Oil Pan\)"](#).

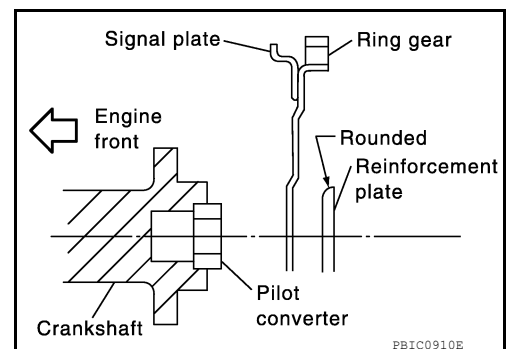

CYLINDER BLOCK

< UNIT DISASSEMBLY AND ASSEMBLY >

[VQ35DE]

24. Remove the engine from the stand and install the engine assembly into the vehicle. Refer to [EM-210](#), "[Removal and Installation](#)".
25. Assembly of the remaining parts is in the reverse order of disassembly.
26. Fill the engine with the specified oil and coolant. Refer to [MA-12](#), "[Fluids and Lubricants](#)".

CAUTION:

Wait at least 30 minutes for the sealant to set-up before filling the engine with fluids and running it.

Inspection

INFOID:000000007420311

PISTON AND PISTON PIN CLEARANCE

Inner Diameter of Piston Pin Hole

- Measure the inner diameter of piston pin hole (dp).

Standard diameter (dp)

Grade No. 0 : 21.993 – 21.999 mm (0.8659 – 0.8661 in)

Grade No. 1 : 21.999 – 22.005 mm (0.8661 – 0.8663 in)

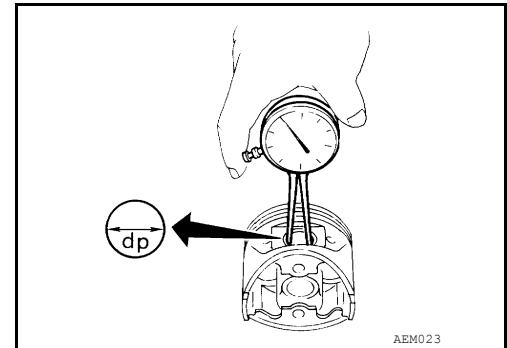

Outer Diameter of Piston Pin

- Measure outer diameter of piston pin (Dp).

Standard diameter (Dp)

Grade No. 0 : 21.989 – 21.995 mm (0.8657 – 0.8659 in)

Grade No. 1 : 21.995 – 22.001 mm (0.8659 – 0.8662 in)

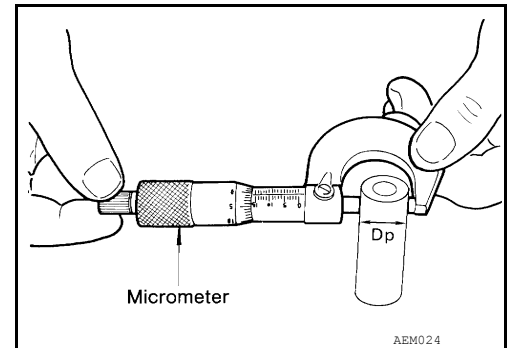

- ⇐: Front
- Piston Grade No. (A)
- Piston front mark (B)
- Oil hole (C)
- Connecting rod front mark (D)
- Cylinder No. (E)
- Pin Grade No. (F)

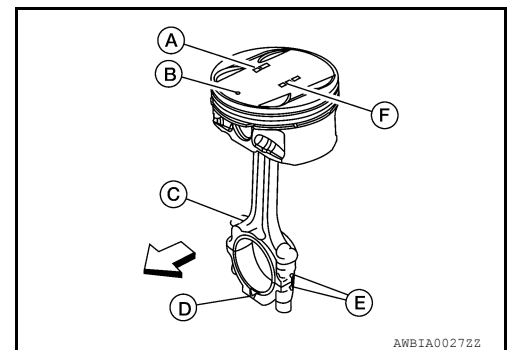

Piston and Piston Pin Interference Fit

Standard Interference Fit = (Dp) – (dp)

Standard : 0.002 – 0.010 mm (0.0001 – 0.0004 in)

- If clearance exceeds specification, replace either or both of piston/piston pin assembly and connecting rod assembly with reference to specification of each part.

PISTON RING SIDE CLEARANCE

CYLINDER BLOCK

[VQ35DE]

< UNIT DISASSEMBLY AND ASSEMBLY >

- Measure side clearance of piston ring and piston ring groove with feeler gauge.

Standard Side Clearance

Top ring	: 0.045 - 0.080 mm (0.0018 - 0.0031 in)
2nd ring	: 0.030 - 0.070 mm (0.0012 - 0.0028 in)
Oil ring	: 0.045 - 0.125 mm (0.0018 - 0.0049 in)

Maximum Limit

Top ring	: 0.11 mm (0.0043 in)
2nd ring	: 0.1 mm (0.004 in)
Oil ring	: —

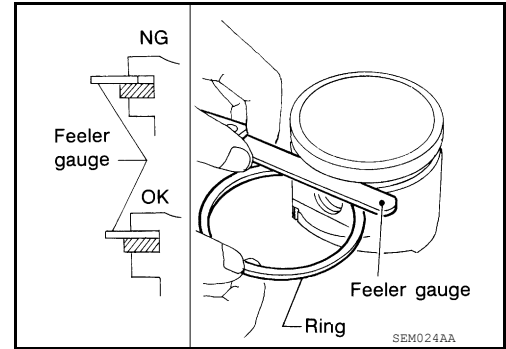

- If out of specification, replace piston ring assembly. If clearance exceeds maximum limit with new rings, replace piston.

PISTON RING END GAP

- Insert piston ring until it is in the middle of the cylinder bore and measure the end gap.

Standard

Top ring	: 0.23 - 0.33 mm (0.0091 - 0.0130 in)
2nd ring	: 0.23 - 0.33 mm (0.0091 - 0.0130 in)
Oil ring	: 0.20 - 0.45 mm (0.0079 - 0.0177 in)

Limit:

Top ring	: 0.54 mm (0.0213 in)
2nd ring	: 0.80 mm (0.0315 in)
Oil ring	: 0.95 mm (0.0374 in)

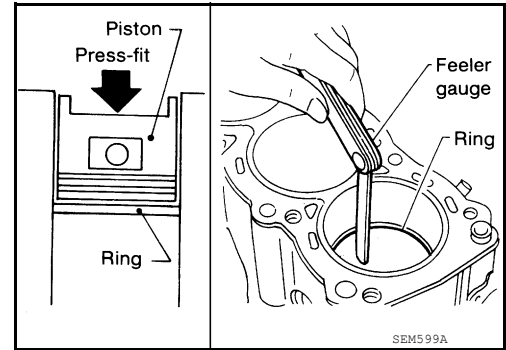

- If out of specification, replace piston ring.

CONNECTING ROD BEND AND TORSION

Bend	: Limit 0.15 mm (0.0059 in) per 100 mm (3.94 in) length
Torsion	: Limit 0.30 mm (0.0118 in) per 100 mm (3.94 in) length

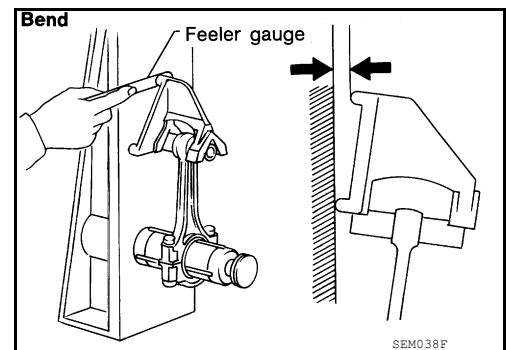

- If it exceeds the limit, replace connecting rod assembly.

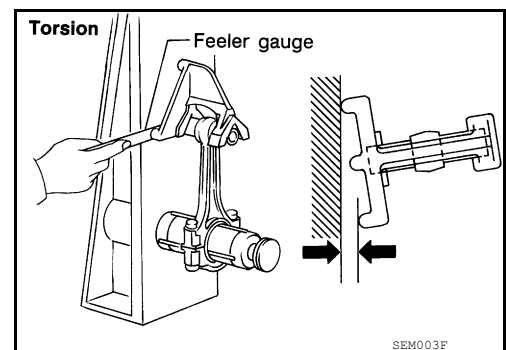

CYLINDER BLOCK

< UNIT DISASSEMBLY AND ASSEMBLY >

[VQ35DE]

CONNECTING ROD BEARING HOUSING DIAMETER (BIG END)

- Install the connecting rod cap without the connecting rod bearing installed. After tightening the connecting rod nut to the specified torque, measure the connecting rod bearing housing big end inner diameter using an inside micrometer.

Standard : 55.000 - 55.013 mm (2.1654 - 2.1659 in)

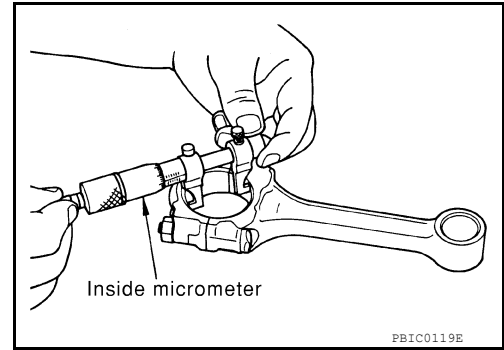

CONNECTING ROD BUSHING OIL CLEARANCE (SMALL END)

Inner Diameter of Connecting Rod (Small End)

- Measure inner diameter of piston pin bushing.

Standard Grade No. 0 : 22.000 - 22.006 mm (0.8661 - 0.8664 in)
Grade No. 1 : 22.006 - 22.012 mm (0.8664 - 0.8666 in)

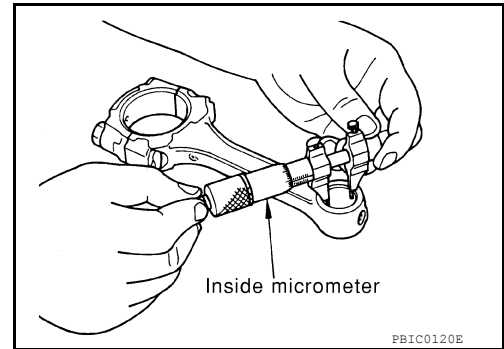

Outer Diameter of Piston Pin

- Measure outer diameter of piston pin.

Standard Grade No. 0 : 21.989 - 21.995 mm (0.8657 - 0.8659 in)
Grade No. 1 : 21.995 - 22.001 mm (0.8659 - 0.8662 in)

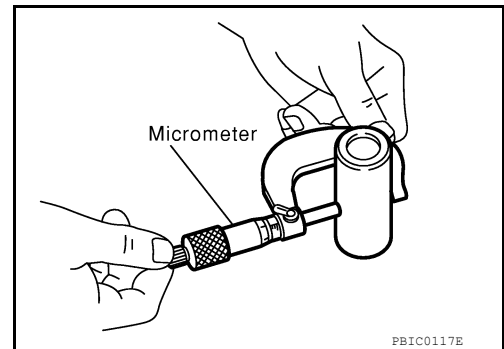

Connecting Rod Bushing Oil Clearance (Small End)

(Connecting rod small end oil clearance) = (Inner diameter of connecting rod small end) – (Outer diameter of piston pin)

Standard : 0.005 - 0.017 mm (0.0002 - 0.0007 in)
Limit : 0.030 mm (0.0012 in)

- If the measured value exceeds the standard, replace the connecting rod assembly and/or piston and piston pin assembly.
- If replacing the piston and piston pin assembly, use the Table for Selective Fitting for Piston to select the piston corresponding to the applicable bore grade of the cylinder block to be used. Follow the "PISTON-TO-CYLINDER BORE CLEARANCE" procedure.

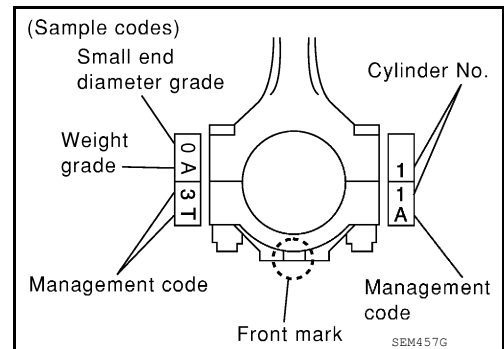

Factory installed parts grading:

CYLINDER BLOCK

< UNIT DISASSEMBLY AND ASSEMBLY >

[VQ35DE]

- ⇐: Front
- Piston Grade No. (A)
- Piston front mark (B)
- Oil hole (C)
- Connecting rod front mark (D)
- Cylinder No. (E)
- Pin Grade No. (F)

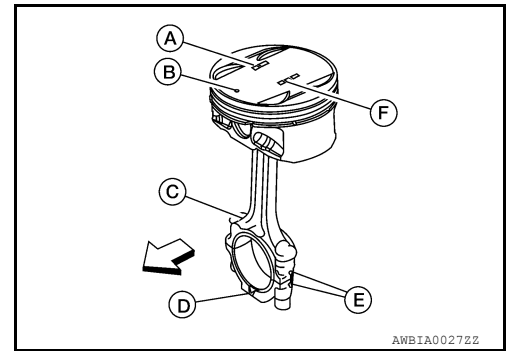

Service parts apply only to grade 0.

Unit: mm (in)

Grade	0	1
Connecting rod small end inner diameter	22.000 - 22.006 (0.8661 - 0.8664)	22.006 - 22.012 (0.8664 - 0.8666)
Piston pin outer diameter	21.989 - 21.995 (0.8657 - 0.8659)	21.995 - 22.001 (0.8659 - 0.8662)
Piston pin hole diameter	21.993 - 21.999 (0.8659 - 0.8661)	21.999 - 22.005 (0.8661 - 0.8663)

CYLINDER BLOCK DISTORTION

- Using a scraper, remove any old gasket material on the cylinder block surface, and remove any oil, scale, carbon, or other contamination.

CAUTION:

Be careful not to allow gasket flakes to enter the oil or coolant passages.

- Measure the distortion on the block upper face at different points in six directions.

Distortion limit : 0.10 mm (0.0039 in)

- If out of specification, resurface the cylinder block. The allowable amount of resurfacing is dependent on the amount of any cylinder head resurfacing. The resurfacing limit is [amount of cylinder head resurfacing] + [amount of cylinder head resurfacing] = 0.2 mm (0.008 in).

**Cylinder block height : 214.95 - 215.05 mm
(8.4626 - 8.4665 in)**

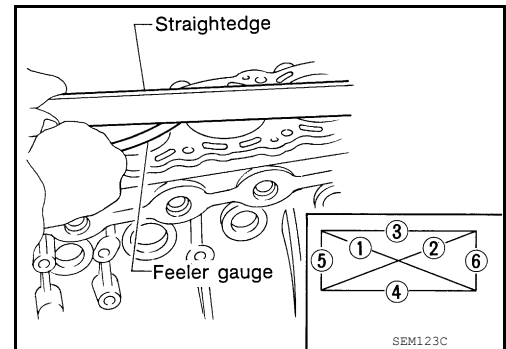

INNER DIAMETER OF MAIN BEARING HOUSING

- Install the main bearing caps with the main bearings removed, and tighten the bolts to the specified torque.
- Using a bore gauge, measure the inner diameter of the main bearing housing (A).

Standard : 63.993 - 64.017 mm (2.5194 - 2.5203 in)

- If out of the standard, replace the cylinder block and main bearing caps as an assembly.

NOTE:

These components cannot be replaced as a single unit, because they were processed together.

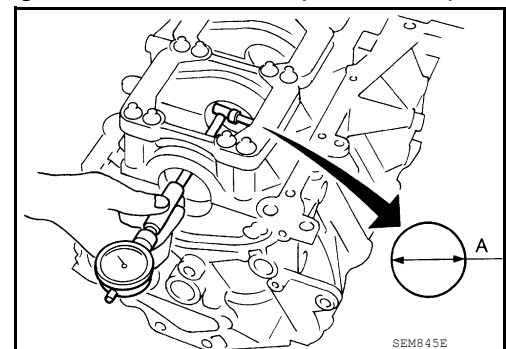

PISTON-TO-CYLINDER BORE CLEARANCE

1. Using a bore gauge, measure cylinder bore for wear, out-of-round and taper at (A), (B) and (C). The X axis is in the longitudinal direction of the engine.

CYLINDER BLOCK

< UNIT DISASSEMBLY AND ASSEMBLY >

[VQ35DE]

Cylinder bore inner diameter

Grade No.	Standard inner diameter	Wear limit
No. 1	95.500 - 95.510 mm (3.7598 - 3.7602 in)	0.20 mm (0.0079 in)
No. 2	95.510 - 95.520 mm (3.7602 - 3.7606 in)	
No. 3	95.520 - 95.530 mm (3.7606 - 3.7610 in)	

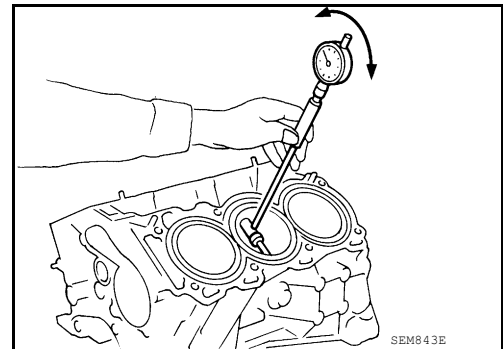

If it exceeds the limit, rebore all cylinders. Replace cylinder block if necessary.

Out-of-round (Difference between X and Y) : limit 0.015 mm (0.0006 in)

Taper (Difference between A and C) : limit 0.015 mm (0.0006 in)

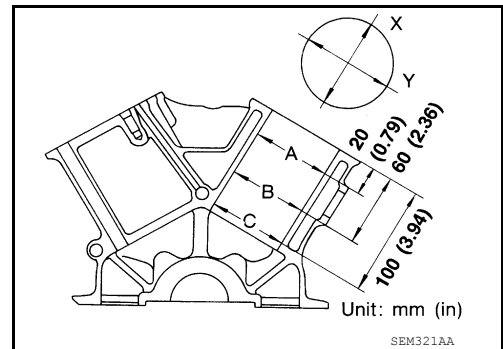

- Check for scratches and seizure. If seizure is found, hone it.
 - If both cylinder block and piston are replaced with new ones, select piston of the same grade number punched on cylinder block rear position. These numbers are punched in either Arabic or Roman numerals.

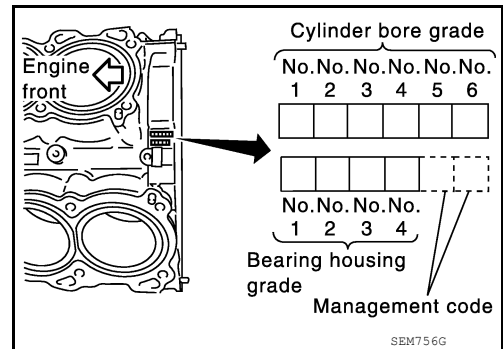

- Measure piston skirt diameter.

Piston diameter (A) : Refer to [EM-243](#), "[Cylinder Block](#)".

Measuring point (a) : 38.0 mm (1.496 in)
(Distance from the top)

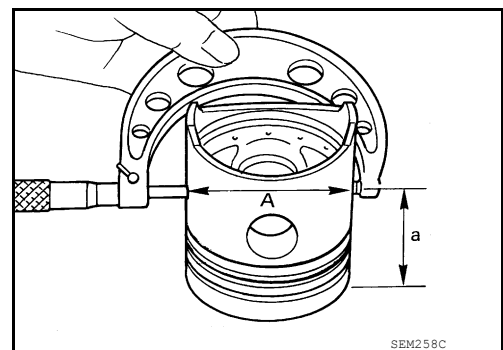

- Check that piston-to-bore clearance is within specification.

Piston-to-cylinder bore clearance at (B) : 0.010 - 0.030 mm (0.0004 - 0.0012 in)

- The piston-to-bore clearance is measured at the (B) level in the cylinder as shown.

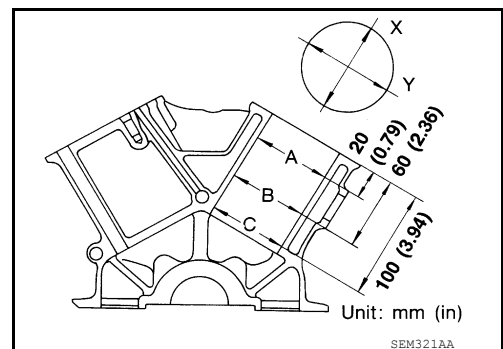

CYLINDER BLOCK

5. Cylinder bore size is determined by adding piston-to-bore clearance to piston diameter (A).

Rebored size calculation : $D = A + B - C$

where,

- (D) : Bored diameter
- (A) : Piston diameter as measured
- (B) : Piston-to-bore clearance
- (C) : Honing allowance 0.02 mm (0.0008 in)

6. Install main bearing caps, and tighten to the specified torque. Otherwise, cylinder bores may be distorted after boring.
7. Cut cylinder bores.
 - **When any cylinder needs boring, all other cylinders must also be bored.**
 - **Do not cut too much out of cylinder bore at a time. Cut only 0.05 mm (0.0020 in) or so in diameter at a time.**
8. Hone cylinders to obtain specified piston-to-bore clearance.
9. Measure finished cylinder bore for out-of-round and taper.
 - **Measurement should be done after cylinder bore cools down.**

CRANKSHAFT

1. Check the crankshaft main and pin journals for scoring, wear, or cracks.
2. Measure the journals for taper and out-of-round.

Standard

Out-of-round (X - Y) : 0.002 mm (0.0001 in)

Taper (A - B) : 0.002 mm (0.0001 in)

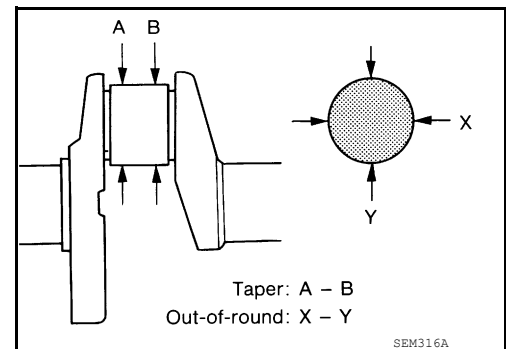

3. Measure crankshaft runout.
 - a. Place a V-block on a precise flat table to support the journals on the both ends of the crankshaft.
 - b. Place a dial gauge straight up on the No. 3 journal.
 - c. While rotating the crankshaft, read the movement of the pointer on the dial gauge.

Runout limit (total indicator reading) : 0.10 mm (0.0039 in)

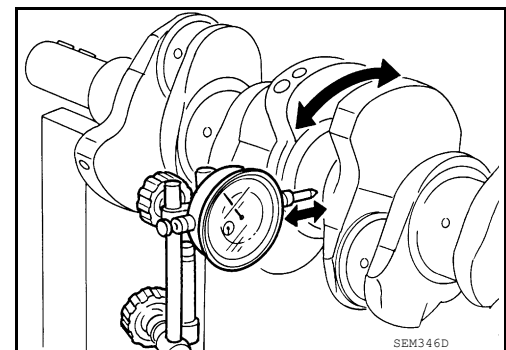

BEARING CLEARANCE

- Use either of the following two methods, however Method A gives more reliable results and so is the preferred method.

Method A (Using Bore Gauge and Micrometer)

Main Bearing

CYLINDER BLOCK

[VQ35DE]

< UNIT DISASSEMBLY AND ASSEMBLY >

1. Set the main bearings in their proper positions on the cylinder block and the main bearing cap.
2. Install the main bearing caps and bearing beam to the cylinder block. Tighten all bolts in the numerical order as specified. Refer to [EM-214, "Disassembly and Assembly"](#).

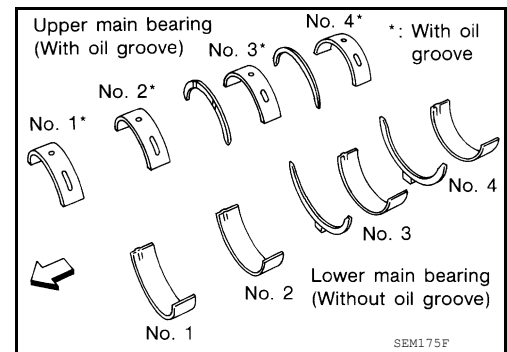

3. Measure the inner diameters (A) of each main bearing as shown.

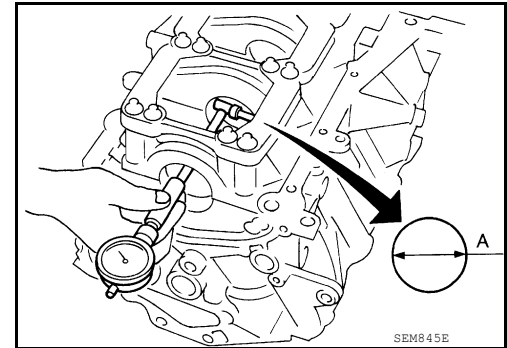

4. Measure the outer diameters (Dm) of each crankshaft main journal as shown.
5. Calculate the main bearing clearance.
Main bearing clearance = (A) - (Dm)

Standard : 0.035 - 0.045 mm (0.0014 - 0.0018 in)

Limit : 0.065 mm (0.0026 in)

- If it exceeds the limit, replace the bearing.
- If clearance cannot be adjusted using any standard bearing grade, grind crankshaft journal and use an undersized bearing.

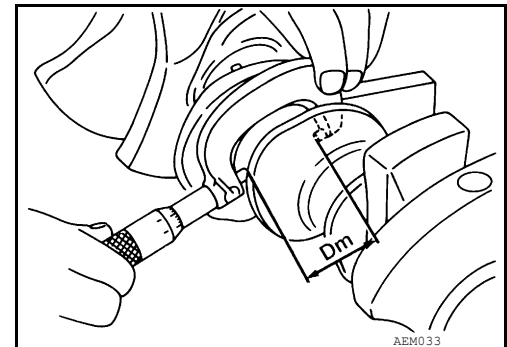

- When grinding the crankshaft journal, confirm that the (L) dimension in the fillet role is more than the specified limit.

(L) : 0.10 mm (0.0039 in)

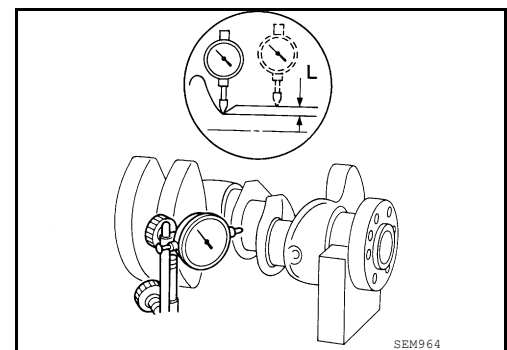

6. If the crankshaft or the cylinder block is replaced with a new one, select thickness of the main bearings as follows:

CYLINDER BLOCK

[VQ35DE]

< UNIT DISASSEMBLY AND ASSEMBLY >

- a. The grade number of each cylinder block main journal is punched on the respective cylinder block. These numbers are punched in either Arabic or Roman numerals. If measured diameter is out of the grade punched, decide suitable grade from available main bearings.

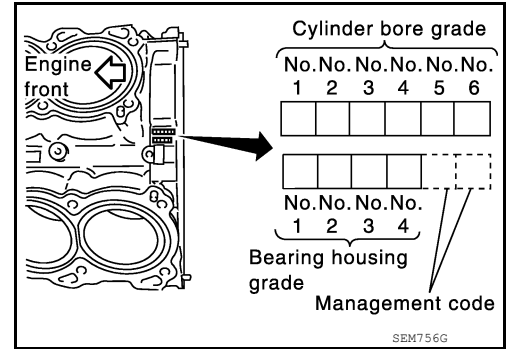

- b. The grade number of each crankshaft main journal is punched on the crankshaft end. These numbers are punched in either Arabic or Roman numerals. If measured diameter is out of grade punched, decide the suitable grade from available main bearings.

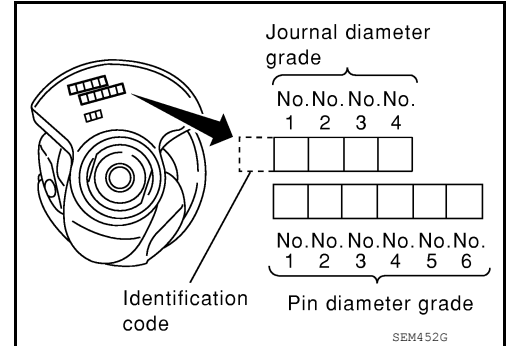

- c. Select the main bearing suitable thickness according to the following table:

Mark	Axle diameter	Cylinder block bearing housing inner diameter Unit: mm (in)																								
		Hole diameter																								
		A	B	C	D	E	F	G	H	J	K	L	M	N	P	R	S	T	U	V	W	X	Y	4	7	
A	59.975 - 59.974 (2.3612 - 2.3612)	0	0	0	0	0	1	1	1	1	1	1	1	1	2	2	2	2	2	3	3	3	3	3	4	4
B	59.974 - 59.973 (2.3612 - 2.3611)	0	0	0	1	1	1	1	1	1	1	1	1	1	2	2	2	2	2	3	3	3	3	3	4	4
C	59.973 - 59.972 (2.3611 - 2.3611)	0	0	0	1	1	1	1	1	1	1	1	1	1	2	2	2	2	2	3	3	3	3	3	4	4
D	59.972 - 59.971 (2.3611 - 2.3611)	0	1	1	1	1	1	1	1	1	1	1	1	1	2	2	2	2	2	3	3	3	3	3	4	4
E	59.971 - 59.970 (2.3611 - 2.3610)	0	1	1	1	1	1	1	1	1	1	1	1	1	2	2	2	2	2	3	3	3	3	3	4	4
F	59.970 - 59.969 (2.3610 - 2.3610)	0	1	1	1	1	1	1	1	1	1	1	1	1	2	2	2	2	2	3	3	3	3	3	4	4
G	59.969 - 59.968 (2.3610 - 2.3609)	1	1	1	1	1	1	1	1	1	1	1	1	1	2	2	2	2	2	3	3	3	3	3	4	4
H	59.968 - 59.967 (2.3609 - 2.3609)	1	1	1	1	1	1	1	1	1	1	1	1	1	2	2	2	2	2	3	3	3	3	3	4	4
J	59.967 - 59.966 (2.3609 - 2.3609)	1	1	1	1	1	1	1	1	1	1	1	1	1	2	2	2	2	2	3	3	3	3	3	4	4
K	59.966 - 59.965 (2.3909 - 2.3608)	1	1	1	1	1	1	1	1	1	1	1	1	1	2	2	2	2	2	3	3	3	3	3	4	4
L	59.965 - 59.964 (2.3608 - 2.3608)	1	1	1	1	1	1	1	1	1	1	1	1	1	2	2	2	2	2	3	3	3	3	3	4	4
M	59.964 - 59.963 (2.3608 - 2.3607)	1	1	1	1	1	1	1	1	1	1	1	1	1	2	2	2	2	2	3	3	3	3	3	4	4
N	59.963 - 59.962 (2.3607 - 2.3607)	1	1	1	1	1	1	1	1	1	1	1	1	1	2	2	2	2	2	3	3	3	3	3	4	4
P	59.962 - 59.961 (2.3607 - 2.3607)	1	1	1	1	1	1	1	1	1	1	1	1	1	2	2	2	2	2	3	3	3	3	3	4	4
R	59.961 - 59.960 (2.3607 - 2.3606)	1	1	1	1	1	1	1	1	1	1	1	1	1	2	2	2	2	2	3	3	3	3	3	4	4
S	59.960 - 59.959 (2.3606 - 2.3606)	1	1	1	1	1	1	1	1	1	1	1	1	1	2	2	2	2	2	3	3	3	3	3	4	4
T	59.959 - 59.958 (2.3606 - 2.3605)	1	1	1	1	1	1	1	1	1	1	1	1	1	2	2	2	2	2	3	3	3	3	3	4	4
U	59.958 - 59.957 (2.3605 - 2.3605)	1	1	1	1	1	1	1	1	1	1	1	1	1	2	2	2	2	2	3	3	3	3	3	4	4
V	59.957 - 59.956 (2.3605 - 2.3605)	1	1	1	1	1	1	1	1	1	1	1	1	1	2	2	2	2	2	3	3	3	3	3	4	4
W	59.956 - 59.955 (2.3605 - 2.3604)	1	1	1	1	1	1	1	1	1	1	1	1	1	2	2	2	2	2	3	3	3	3	3	4	4
X	59.955 - 59.954 (2.3604 - 2.3604)	1	1	1	1	1	1	1	1	1	1	1	1	1	2	2	2	2	2	3	3	3	3	3	4	4
Y	59.954 - 59.953 (2.3604 - 2.3603)	1	1	1	1	1	1	1	1	1	1	1	1	1	2	2	2	2	2	3	3	3	3	3	4	4
4	59.953 - 59.952 (2.3603 - 2.3603)	1	1	1	1	1	1	1	1	1	1	1	1	1	2	2	2	2	2	3	3	3	3	3	4	4
7	59.952 - 59.951 (2.3603 - 2.3603)	1	1	1	1	1	1	1	1	1	1	1	1	1	2	2	2	2	2	3	3	3	3	3	4	4

CYLINDER BLOCK

< UNIT DISASSEMBLY AND ASSEMBLY >

[VQ35DE]

Connecting Rod Bearing (Big End)

1. Install the connecting rod bearing to the connecting rod and cap.
2. Install the connecting rod cap to the connecting rod. Tighten to specification. Refer to [EM-214, "Disassembly and Assembly"](#).
3. Measure the inner diameter (C) of each connecting rod (big end) as shown.

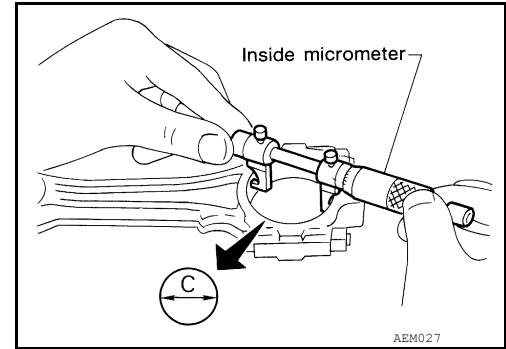

4. Measure the outer diameter (Dp) of each crankshaft pin journal.
5. Calculate the connecting rod bearing clearance.
Connecting rod bearing clearance = (C) - (Dp)

Standard : 0.020 - 0.045 mm (0.0008 - 0.0018 in)

Limit : 0.070 mm (0.0028 in)

6. If the calculated clearance exceeds the specified limit, replace the bearings.
7. If the clearance cannot be adjusted within the standard of any bearing, grind the crankshaft journal and use undersized bearings.

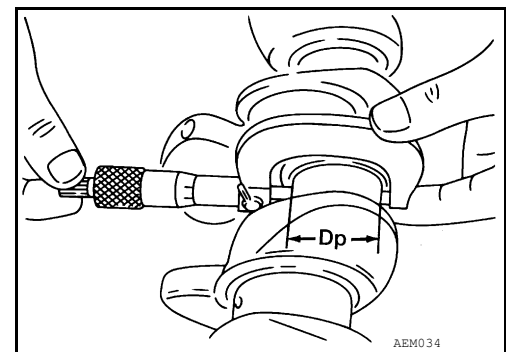

8. If the crankshaft is replaced with a new one, select the connecting rod bearings according to the following table:
Connecting Rod Bearing Grade Number (Identification Color)

Crankshaft pin journal grade number	Connecting rod bearing grade number
0	0 (black)
1	1 (brown)
2	2 (green)

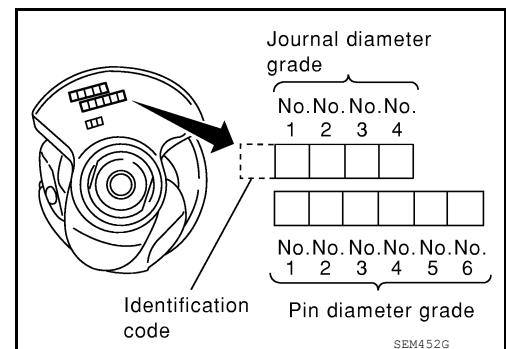

These numbers are punched in either Arabic or Roman numerals.

Method B (Using Plastigage)

- Remove oil and dust on the crankshaft pin and the surfaces of each bearing completely.
- Cut a Plastigage slightly shorter than the bearing width, and place it in crankshaft axial direction, avoiding oil holes.
- Install the connecting rod bearings to the connecting rod cap, and tighten the connecting rod nuts to the specified torque.

CAUTION:

Do not rotate the crankshaft.

- Remove the connecting rod cap and bearings, and using the scale on the Plastigage bag, measure the Plastigage width.

NOTE:

The procedure when the measured value exceeds the repair limit is same as that described in "Method A (Using Bore Gauge and Micrometer)".

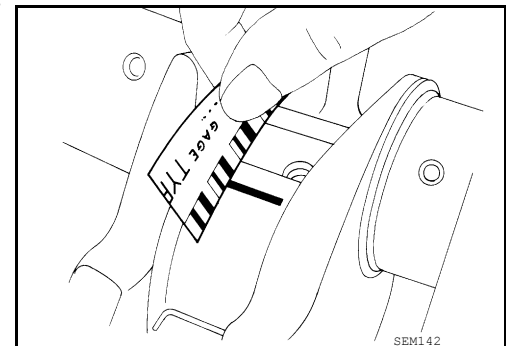

DRIVE PLATE RUNOUT

CYLINDER BLOCK

< UNIT DISASSEMBLY AND ASSEMBLY >

[VQ35DE]

Runout (Total Indicator Reading):

Drive plate

Torque converter sur- : less than 0.35mm (0.0138 in)
face

Ring gear : less than 0.5mm (0.0197 in)

CAUTION:

- The signal plate is built into the drive assembly. Be careful not to damage the signal plate, particularly the teeth.
- Check the drive plate and signal plate for deformation or cracks.
- Keep any magnetized objects away from the signal plate, particularly the teeth.

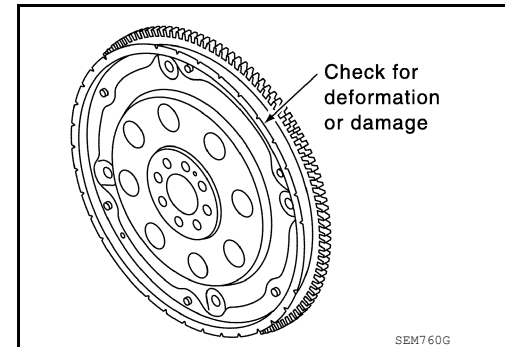
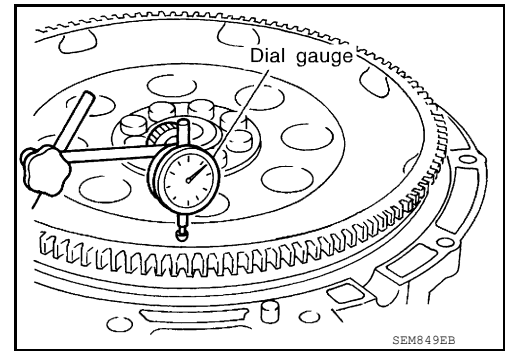

OIL JET

- Check nozzle for deformation and damage.
- Blow compressed air from nozzle, and check for clogs.
- If oil port cannot be cleared, replace oil jet.

OIL JET RELIEF VALVE

- Using a clean plastic stick, press check valve in oil jet relief valve. Make sure that valve moves smoothly with proper reaction force.
- If relief valve sticks or binds, replace oil jet relief valve.

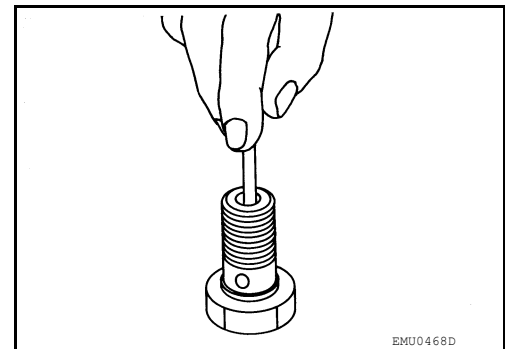

Dowel Pin Alignment

INFOID:000000007420312

REMOVAL

1. Use suitable tool to lock the drive plate and match mark (A) before removing the bolts.

CAUTION:

Do not damage the ring gear teeth, or the signal plate teeth behind the ring gear, when setting Tool.

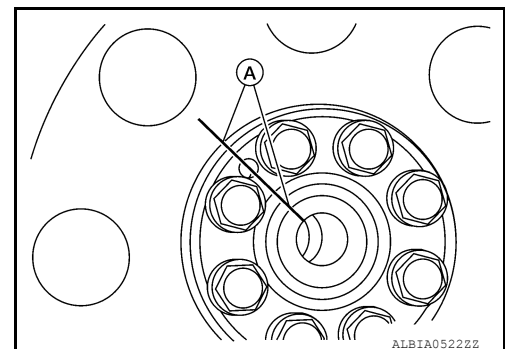

CYLINDER BLOCK

< UNIT DISASSEMBLY AND ASSEMBLY >

[VQ35DE]

2. Remove the drive plate.
 - Loosen the drive plate bolts in a diagonal order.
 - CAUTION:**
 - **Do not disassemble the drive plate.**
 - **Do not place drive plate with signal plate facing down.**
 - **When handling the signal plate, take care not to damage or scratch it.**
 - **Handle the signal plate in a manner that prevents it from becoming magnetized.**

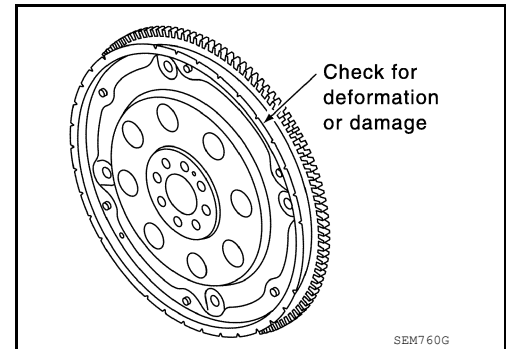

INSTALLATION

Installation is in the reverse order of removal.

- When installing the drive plate to the crankshaft, use the triangle shaped match mark (A) as shown to correctly align the crankshaft side dowel pin to the drive plate side dowel pin hole.

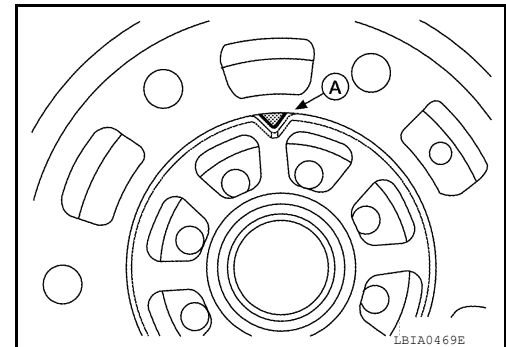

- Install the drive plate and drive plate reinforcement plate in the direction as shown.
- Tighten the drive plate bolts in a diagonal pattern in two steps. Refer to [EM-214, "Disassembly and Assembly"](#).

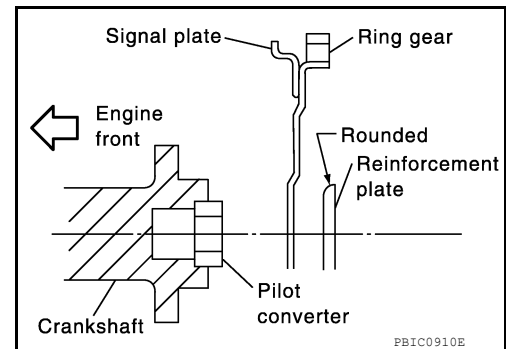

SERVICE DATA AND SPECIFICATIONS (SDS)

< SERVICE DATA AND SPECIFICATIONS (SDS)

[VQ35DE]

SERVICE DATA AND SPECIFICATIONS (SDS)

SERVICE DATA AND SPECIFICATIONS (SDS)

General Specification

INFOID:000000007420313

GENERAL SPECIFICATIONS

Cylinder arrangement		V-6
Displacement cm ³ (cu in)		3,498 (213.45)
Bore and stroke mm (in)		95.5 x 81.4 (3.760 x 3.205)
Valve arrangement		DOHC
Firing order		1-2-3-4-5-6
Number of piston rings	Compression	2
	Oil	1
Number of main bearings		4
Compression ratio		10.3:1
Compression pressure kPa (bar, kg/cm ² , psi)/300 rpm	Standard	1,275 (12.75, 13.0, 185)
	Minimum	981 (9.81, 10.0, 142)
	Differential limit between cylinders	98 (0.98, 1.0, 14)

Cylinder number

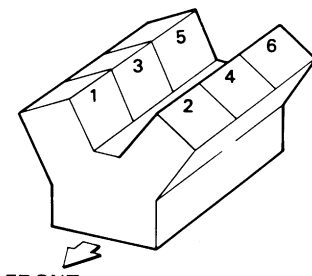

SEM713A

Valve timing
(Valve timing control - "OFF")

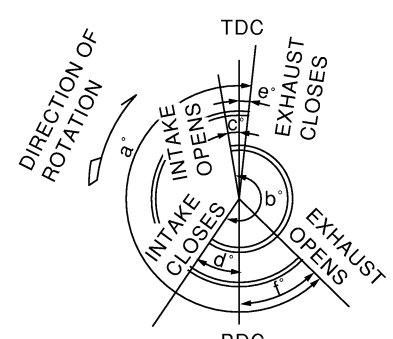

PBIC0187E

Unit: degree

a	b	c	d	e	f
240	240	-10	70	10	50

Drive Belt

INFOID:000000007420314

DRIVE BELT

Tension of drive belt	Belt tension is not necessary, as it is automatically adjusted by drive belt auto-tensioner.
-----------------------	--

SERVICE DATA AND SPECIFICATIONS (SDS)

< SERVICE DATA AND SPECIFICATIONS (SDS)

[VQ35DE]

Spark Plug

INFOID:000000007420315

SPARK PLUG

Unit: mm (in)

Make	DENSO
Standard type*	FXE22HR-11
Gap	Standard 1.1 (0.043)

*: Always check with the Parts Department for the latest parts information.

Intake Manifold

INFOID:000000007420316

INTAKE MANIFOLD

Unit: mm (in)

	Items	Limit
Surface distortion	Intake manifold collector	0.1 (0.004)
	Intake manifold	0.1 (0.004)

Exhaust Manifold

INFOID:000000007420317

EXHAUST MANIFOLD

Unit: mm (in)

	Items	Limit
Surface distortion	Exhaust manifold	0.3 (0.012)

Camshaft

INFOID:000000007420318

CAMSHAFT

Unit: mm (in)

	Items	Standard	Limit
Camshaft journal oil clearance	No. 1	0.045 - 0.086 (0.0018 - 0.0034)	0.15 (0.0059)
	No. 2, 3, 4	0.035 - 0.076 (0.0014 - 0.0030)	
Camshaft bracket inner diameter	No. 1	26.000 - 26.021 (1.0236 - 1.0244)	—
	No. 2, 3, 4	23.500 - 23.521 (0.9252 - 0.9260)	—
Camshaft journal outer diameter	No. 1	25.935 - 25.955 (1.0211 - 1.0218)	—
	No. 2, 3, 4	23.445 - 23.465 (0.9230 - 0.9238)	—
Camshaft end play		0.115 - 0.188 (0.0045 - 0.0074)	0.24 (0.0094)
Camshaft cam height (A)	Intake	45.475 - 45.665 (1.7904 - 1.7978)	0.2 (0.008)* ¹
	Exhaust	45.485 - 45.675 (1.7907 - 1.7982)	0.2 (0.008)* ¹
Camshaft runout [TIR* ²]		Less than 0.02 (0.0008)	0.05 (0.0020)
Camshaft sprocket runout [TIR* ²]		Less than 0.15 (0.0059)	—

SERVICE DATA AND SPECIFICATIONS (SDS)

< SERVICE DATA AND SPECIFICATIONS (SDS)

[VQ35DE]

Difference in level between front end faces of No. 1 camshaft bracket and cylinder head	-0.14 (-0.0055)	—
---	-----------------	---

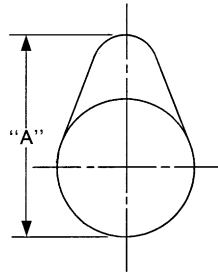

- *1: Cam wear limit
- *2: Total indicator reading

VALVE LIFTER

Unit: mm (in)

Items	Standard
Valve lifter outer diameter	33.977 - 33.987 (1.3377 - 1.3381)
Valve lifter hole diameter	34.000 - 34.016 (1.3386 - 1.3392)
Valve lifter clearance	0.013 - 0.039 (0.0005 - 0.0015)

VALVE CLEARANCE

Unit: mm (in)

Items	Cold	Hot* (reference data)
Intake	0.26 - 0.34 (0.010 - 0.013)	0.304 - 0.416 (0.012 - 0.016)
Exhaust	0.29 - 0.37 (0.011 - 0.015)	0.308 - 0.432 (0.012 - 0.017)

*: Approximately 80°C (176°F)

AVAILABLE VALVE LIFTER

Unit: mm (in)

Identification (stamped) mark*	Thickness
788C	7.88 (0.3102)
790C	7.90 (0.3110)
792C	7.92 (0.3118)
794C	7.94 (0.3126)
796C	7.96 (0.3134)
798C	7.98 (0.3142)
800C	8.00 (0.3150)
802C	8.02 (0.3157)
804C	8.04 (0.3165)
806C	8.06 (0.3173)
808C	8.08 (0.3181)
810C	8.10 (0.3189)
812C	8.12 (0.3197)
814C	8.14 (0.3205)
816C	8.16 (0.3213)
818C	8.18 (0.3220)

SERVICE DATA AND SPECIFICATIONS (SDS)

< SERVICE DATA AND SPECIFICATIONS (SDS)

[VQ35DE]

Identification (stamped) mark*	Thickness
820C	8.20 (0.3228)
822C	8.22 (0.3236)
824C	8.24 (0.3244)
826C	8.26 (0.3252)
828C	8.28 (0.3260)
830C	8.30 (0.3268)
832C	8.32 (0.3276)
834C	8.34 (0.3283)
836C	8.36 (0.3291)
838C	8.38 (0.3299)
840C	8.40 (0.3307)

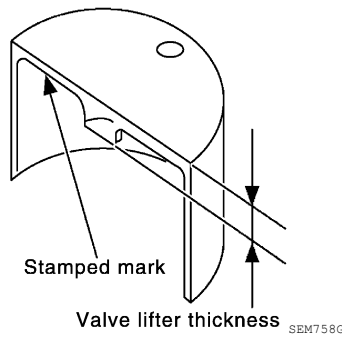

*: Always check with the Parts Department for the latest parts information.

Cylinder Head

INFOID:000000007420319

CYLINDER HEAD

Unit: mm (in)

Items	Standard	Limit
Head surface distortion	Less than 0.03 (0.0012)	0.1 (0.004)
Normal cylinder head height (H)	126.3 - 126.5 (4.972 - 4.980)	—
Spark plug tube installation height	37.7 - 38.7 (1.484 - 1.529)	—

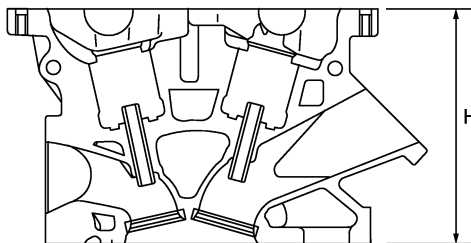

PBIC0924E

VALVE DIMENSIONS

SERVICE DATA AND SPECIFICATIONS (SDS)

< SERVICE DATA AND SPECIFICATIONS (SDS)

[VQ35DE]

Unit: mm (in)

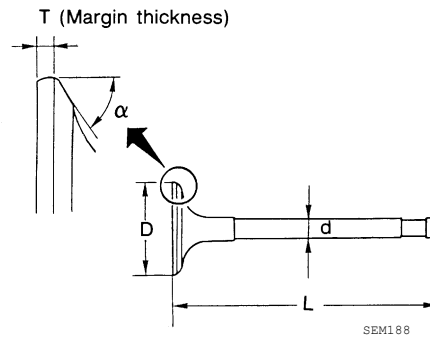

Valve head diameter (D)	Intake	36.6 - 36.9 (1.441 - 1.453)
	Exhaust	30.2 - 30.5 (1.189 - 1.201)
Valve length (L)	Intake	97.13 (3.8240)
	Exhaust	94.67 (3.7272)
Valve stem diameter (d)	Intake	5.965 - 5.980 (0.2348 - 0.2354)
	Exhaust	5.955 - 5.970 (0.2344 - 0.2350)
Valve seat angle (α)	Intake	45° 15' - 45° 45'
	Exhaust	
Valve margin (T)	Intake	1.15 - 1.45 (0.0453 - 0.0571)
	Exhaust	1.45 - 1.75 (0.0571 - 0.0689)
Valve margin (T) limit		More than 0.5 (0.020)
Valve stem end surface grinding limit		Less than 0.2 (0.008)

VALVE OIL SEAL

Unit: mm (in)

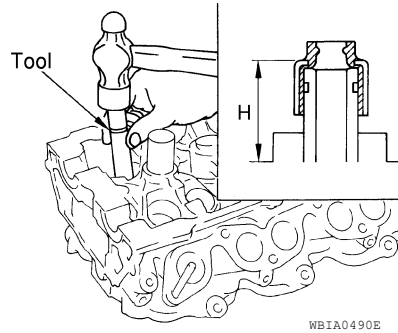

Description	Standard
Valve oil seal installation height (H)	14.3 - 14.9 (0.563 - 0.587)

VALVE GUIDE

SERVICE DATA AND SPECIFICATIONS (SDS)

< SERVICE DATA AND SPECIFICATIONS (SDS)

[VQ35DE]

Unit: mm (in)

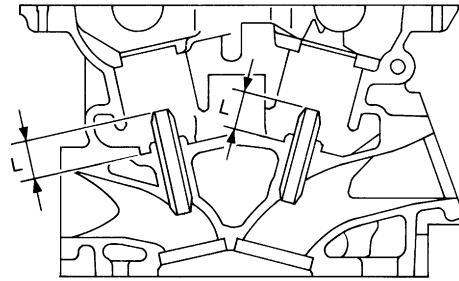

SEM950E

Items		Standard	Oversize (Service) [0.2 (0.008)]
Valve guide	Outer diameter	10.023 - 10.034 (0.3946 - 0.3950)	10.223 - 10.234 (0.4025 - 0.4029)
	Inner diameter (Finished size)	6.000 - 6.018 (0.2362 - 0.2369)	
Cylinder head valve guide hole diameter		9.975 - 9.996 (0.3927 - 0.3935)	10.175 - 10.196 (0.4006 - 0.4014)
Interference fit of valve guide		0.027 - 0.059 (0.0011 - 0.0023)	
Items		Standard	Limit
Valve to valve guide clearance	Intake	0.020 - 0.053 (0.0008 - 0.0021)	0.08 (0.0031)
	Exhaust	0.040 - 0.073 (0.0016 - 0.0029)	0.01 (0.004)
Valve deflection	Intake	—	0.24 (0.0094)
	Exhaust	—	0.28 (0.0110)
Projection length (L)		12.6 - 12.8 (0.496 - 0.504)	

VALVE SEAT

SERVICE DATA AND SPECIFICATIONS (SDS)

< SERVICE DATA AND SPECIFICATIONS (SDS)

[VQ35DE]

Unit: mm (in)

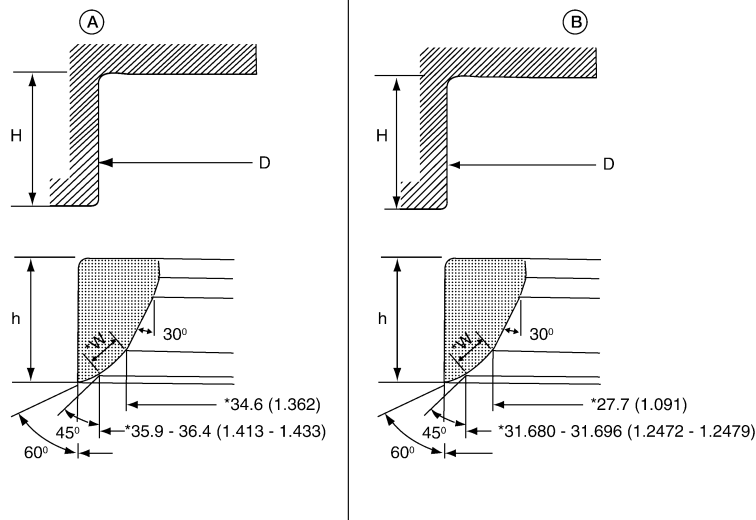

AWBIA0033GB

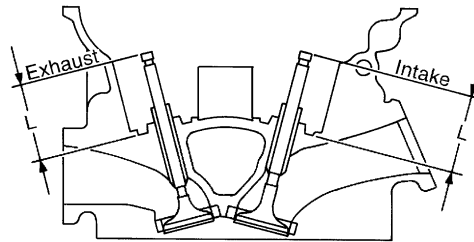

SEM621F

Items		Standard	Oversize (Service) [0.5 (0.020)]
Cylinder head seat recess diameter (D)	Intake (A)	38.000 - 38.016 (1.4961 - 1.4967)	38.500 - 38.516 (1.5157 - 1.5164)
	Exhaust (B)	31.600 - 31.616 (1.2441 - 1.2447)	32.100 - 32.116 (1.2638 - 1.2644)
Valve seat outer diameter	Intake	38.097 - 38.113 (1.4999 - 1.5005)	38.597 - 38.613 (1.5196 - 1.5202)
	Exhaust	31.680 - 31.696 (1.2472 - 1.2479)	32.180 - 32.196 (1.2669 - 1.2676)
Valve seat interference fit	Intake	0.081 - 0.113 (0.0032 - 0.0044)	
	Exhaust	0.064 - 0.096 (0.0025 - 0.0038)	
Height (h)	Intake (A)	5.9 - 6.0 (0.232 - 0.236)	5.05 - 5.15 (0.1988 - 0.2028)
	Exhaust (B)	5.9 - 6.0 (0.232 - 0.236)	4.95 - 5.05 (0.1949 - 0.1988)
Contacting width (W)*	Intake (A)	1.18 - 1.22 (0.0465 - 0.0480)	
	Exhaust (B)	1.38 - 1.42 (0.0543 - 0.0559)	
Cylinder head seat recess depth (H)		6.0 (0.236)	
Depth (L) for valve seat resurface limit	Intake (A)	41.16 - 41.76 (1.6205 - 1.6441)	
	Exhaust (B)	41.09 - 41.69 (1.6177 - 1.6413)	

*:Machining data

VALVE SPRING

Items	Standard
Free height	47.07 mm (1.8531 in)
Installation height	37.0 mm (1.457 in)
Installation load	166 - 188 N (1.66 - 1.88 bar, 16.9 - 19.2 kg-f, 37.3 - 42.3 lb-f)

SERVICE DATA AND SPECIFICATIONS (SDS)

< SERVICE DATA AND SPECIFICATIONS (SDS)

[VQ35DE]

Items	Standard
Height during valve open	27.2 mm (1.071 in)
Load with valve open	373 - 421 N (3.73 - 4.21 bar, 38.0 - 42.9 kg-f, 84 - 95 lb-f)

Unit: mm (in)

Items	Limit
Out of square	Less than 2.0 (0.079)

Cylinder Block

INFOID:000000007420320

CYLINDER BLOCK

Unit: mm (in)

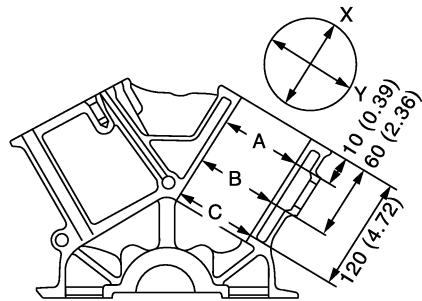

JPBIA2238GB

Surface distortion		Standard		Less than 0.03 (0.0012)
		Limit		0.10 (0.0039)
Main bearing housing inner diameter		Standard		63.993 - 64.017 (2.5194 - 2.5203)
Cylinder bore	Inner diameter	Standard	Grade No. 1*	95.500 - 95.510 (3.7598 - 3.7602)
			Grade No. 2*	95.510 - 95.520 (3.7602 - 3.7606)
			Grade No. 3*	95.520 - 95.530 (3.7606 - 3.7610)
		Wear limit		0.20 (0.0079)
Out-of-round		Limit		0.015 (0.0006)
Taper (Difference between A and C)				0.015 (0.0006)

SERVICE DATA AND SPECIFICATIONS (SDS)

< SERVICE DATA AND SPECIFICATIONS (SDS)

[VQ35DE]

Main bearing housing inner diameter grade (Without bearing) grade*	Grade No. A	63.993 - 63.994 (2.5194 - 2.5194)
	Grade No. B	63.994 - 63.995 (2.5194 - 2.5195)
	Grade No. C	63.995 - 63.996 (2.5195 - 2.5195)
	Grade No. D	63.996 - 63.997 (2.5195 - 2.5196)
	Grade No. E	63.997 - 63.998 (2.5196 - 2.5196)
	Grade No. F	63.998 - 63.999 (2.5196 - 2.5196)
	Grade No. G	63.999 - 64.000 (2.5196 - 2.5197)
	Grade No. H	64.000 - 64.001 (2.5197 - 2.5197)
	Grade No. J	64.001 - 64.002 (2.5197 - 2.5198)
	Grade No. K	64.002 - 64.003 (2.5198 - 2.5198)
	Grade No. L	64.003 - 64.004 (2.5198 - 2.5198)
	Grade No. M	64.004 - 64.005 (2.5198 - 2.5199)
	Grade No. N	64.005 - 64.006 (2.5199 - 2.5199)
	Grade No. P	64.006 - 64.007 (2.5199 - 2.5200)
	Grade No. R	64.007 - 64.008 (2.5200 - 2.5200)
	Grade No. S	64.008 - 64.009 (2.5200 - 2.5200)
	Grade No. T	64.009 - 64.010 (2.5200 - 2.5201)
	Grade No. U	64.010 - 64.011 (2.5201 - 2.5201)
	Grade No. V	64.011 - 64.012 (2.5201 - 2.5202)
Grade No. W	64.012 - 64.013 (2.5202 - 2.5202)	
Grade No. X	64.013 - 64.014 (2.5202 - 2.5202)	
Grade No. Y	64.014 - 64.015 (2.5202 - 2.5203)	
Grade No. 4	64.015 - 64.016 (2.5203 - 2.5203)	
Grade No. 7	64.016 - 64.017 (2.5203 - 2.5203)	
Difference in inner diameter between cylinders	Standard	Less than 0.03 (0.0012)

*:Always check with the Parts Department for the latest parts information.

AVAILABLE PISTON

Unit: mm (in)

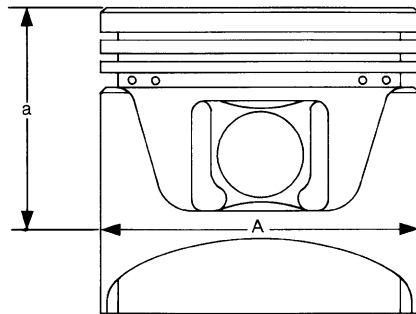

Items	Grade*	Standard
Piston skirt diameter (A)	Grade No. 1	95.480 - 95.490 (3.7590 - 3.7594)
	Grade No. 2	95.490 - 95.500 (3.7594 - 3.7598)
	Grade No. 3	95.500 - 95.510 (3.7598 - 3.7602)
(a) dimension		38.0 (1.496)
Piston pin hole diameter	Grade No. 0	21.993 - 21.999 (0.8659 - 0.8661)
	Grade No. 1	21.999 - 22.005 (0.8661 - 0.8663)
Piston to cylinder bore clearance		0.010 - 0.030 (0.0004 - 0.0012)

*: Always check with the Parts Department for the latest parts information.

PISTON RING

Unit: mm (in)

Items	Standard	Limit	
Side clearance	Top	0.045 - 0.080 (0.0018 - 0.0031)	0.11 (0.0043)
	2nd	0.030 - 0.070 (0.0012 - 0.0028)	0.1 (0.004)
	Oil ring	0.045 - 0.125 (0.0018 - 0.0049)	—

SERVICE DATA AND SPECIFICATIONS (SDS)

< SERVICE DATA AND SPECIFICATIONS (SDS)

[VQ35DE]

End gap	Top	0.23 - 0.33 (0.0091 - 0.0130)	0.54 (0.0213)
	2nd	0.23 - 0.33 (0.0091 - 0.0130)	0.80 (0.0315)
	Oil (rail ring)	0.20 - 0.45 (0.0079 - 0.0177)	0.95 (0.0374)

PISTON PIN

Unit: mm (in)

Items	Grade*	Standard	Limit
Piston pin outer diameter	Grade No. 0	21.989 - 21.995 (0.8657 - 0.8659)	—
	Grade No. 1	21.995 - 22.001 (0.8659 - 0.8662)	—
Piston to piston pin oil clearance		0.002 - 0.006 (0.0001 - 0.0002)	—
Connecting rod bushing oil clearance		0.005 - 0.017 (0.0002 - 0.0007)	0.030 (0.0012)

*: Always check with the Parts Department for the latest parts information.

CONNECTING ROD

Unit: mm (in)

Items	Grade ¹	Standard	Limit
Center distance		144.15 - 144.25 (5.6752 - 5.6791)	—
Bend [per 100 (3.94)]		—	0.15 (0.0059)
Torsion [per 100 (3.94)]		—	0.30 (0.0118)
Connecting rod small end inner diameter		23.980 - 24.000 (0.9441 - 0.9449)	—
Connecting rod bushing inner diameter ²	Grade No. 0	22.000 - 22.006 (0.8661 - 0.8664)	—
	Grade No. 1	22.006 - 22.012 (0.8664 - 0.8666)	—
Connecting rod big end diameter (Without bearing)		55.000 - 55.013 (2.1654 - 2.1659)	—
Side clearance		0.20 - 0.35 (0.0079 - 0.0138)	0.40 (0.0157)

¹: Always check with the Parts Department for the latest parts information.

²: After installing in connecting rod.

CRANKSHAFT

Unit: mm (in)

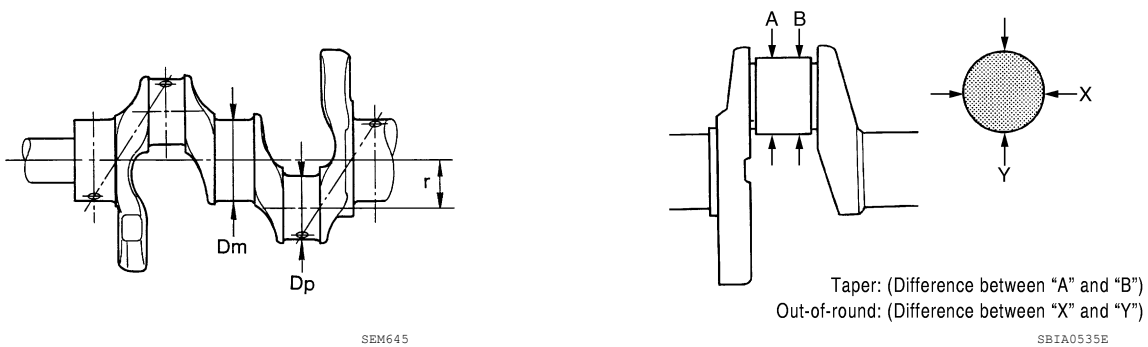

SERVICE DATA AND SPECIFICATIONS (SDS)

< SERVICE DATA AND SPECIFICATIONS (SDS)

[VQ35DE]

		Grade ¹	Dimension
Main journal diameter. (Dm) grade	Standard	Grade No. A	59.975 - 59.974 (2.3612 - 2.3612)
		Grade No. B	59.974 - 59.973 (2.3612 - 2.3611)
		Grade No. C	59.973 - 59.972 (2.3611 - 2.3611)
		Grade No. D	59.972 - 59.971 (2.3611 - 2.3611)
		Grade No. E	59.971 - 59.970 (2.3611 - 2.3610)
		Grade No. F	59.970 - 59.969 (2.3610 - 2.3610)
		Grade No. G	59.969 - 59.968 (2.3610 - 2.3609)
		Grade No. H	59.968 - 59.967 (2.3609 - 2.3609)
		Grade No. J	59.967 - 59.966 (2.3609 - 2.3609)
		Grade No. K	59.966 - 59.965 (2.3609 - 2.3608)
		Grade No. L	59.965 - 59.964 (2.3608 - 2.3608)
		Grade No. M	59.964 - 59.963 (2.3608 - 2.3607)
		Grade No. N	59.963 - 59.962 (2.3607 - 2.3607)
		Grade No. P	59.962 - 59.961 (2.3607 - 2.3607)
		Grade No. R	59.961 - 59.960 (2.3607 - 2.3606)
		Grade No. S	59.960 - 59.959 (2.3606 - 2.3606)
		Grade No. T	59.959 - 59.958 (2.3606 - 2.3605)
		Grade No. U	59.958 - 59.957 (2.3605 - 2.3605)
		Grade No. V	59.957 - 59.956 (2.3605 - 2.3605)
		Grade No. W	59.956 - 59.955 (2.3605 - 2.3604)
Grade No. X	59.955 - 59.954 (2.3604 - 2.3604)		
Grade No. Y	59.954 - 59.953 (2.3604 - 2.3603)		
Grade No. 4	59.953 - 59.952 (2.3603 - 2.3603)		
Grade No. 7	59.952 - 59.951 (2.3603 - 2.3603)		
Pin journal diameter. (Dp) grade	Standard	Grade No. 0	51.968 - 51.974 (2.0460 - 2.0462)
		Grade No. 1	51.962 - 51.968 (2.0457 - 2.0460)
		Grade No. 2	51.956 - 51.962 (2.0445 - 2.0457)
Center distance (r)			40.36 - 40.44 (1.5890 - 1.5921)
Taper [Difference between (A) and (B)]	Limit		Less than 0.002 (0.0001)
Out-of-round [Difference between (X) and (Y)]			Less than 0.002 (0.0001)
Crankshaft runout [TIR ²]	Standard		Less than 0.05 (0.0020)
	Limit		0.10 (0.0039)
Crankshaft end play	Standard		0.10 - 0.25 (0.0039 - 0.0098)
	Limit		0.30 (0.0118)
Fillet role of crankshaft journal	Standard		More than 0.10 (0.0039)

¹: Always check with the Parts Department for the latest parts information.

²: Total indicator reading

Main Bearing

INFOID:000000007420321

MAIN BEARING

Unit: mm (in)

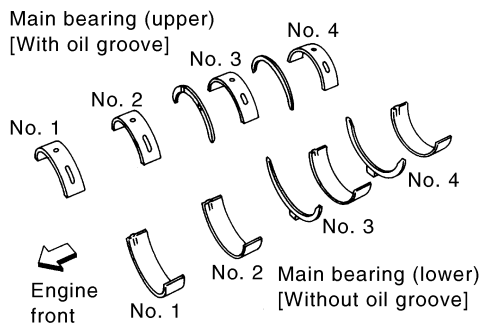

Grade number*	Thickness	Width	Identification color	Remarks
---------------	-----------	-------	----------------------	---------

SERVICE DATA AND SPECIFICATIONS (SDS)

< SERVICE DATA AND SPECIFICATIONS (SDS)

[VQ35DE]

0		2.000 - 2.003 (0.0787 - 0.0789)		Black	Grade is the same for upper and lower bearings.	A
1		2.003 - 2.006 (0.0789 - 0.0790)		Brown		EM
2		2.006 - 2.009 (0.0790 - 0.0791)		Green		C
3		2.009 - 2.012 (0.0791 - 0.0792)		Yellow		D
4		2.012 - 2.015 (0.0792 - 0.0793)		Blue		E
5		2.015 - 2.018 (0.0793 - 0.0794)		Pink		F
6		2.018 - 2.021 (0.0794 - 0.0796)		Purple		G
7		2.021 - 2.024 (0.0796 - 0.0797)		White		H
01	UPR	2.003 - 2.006 (0.0789 - 0.0790)	19.9 - 20.1 (0.783 - 0.791)	Brown	Grade and color are different for upper and lower bearings.	I
	LWR	2.000 - 2.003 (0.0787 - 0.0789)		Black		J
12	UPR	2.006 - 2.009 (0.0790 - 0.0791)		Green		K
	LWR	2.003 - 2.006 (0.0789 - 0.0790)		Brown		L
23	UPR	2.009 - 2.012 (0.0791 - 0.0792)		Yellow		M
	LWR	2.006 - 2.009 (0.0790 - 0.0791)		Green		N
34	UPR	2.012 - 2.015 (0.0792 - 0.0793)		Blue		O
	LWR	2.009 - 2.012 (0.0791 - 0.0792)		Yellow		P
45	UPR	2.015 - 2.018 (0.0793 - 0.0794)		Pink		
	LWR	2.012 - 2.015 (0.0792 - 0.0793)		Blue		
56	UPR	2.018 - 2.021 (0.0794 - 0.0796)		Purple		
	LWR	2.015 - 2.018 (0.0793 - 0.0794)		Pink		
67	UPR	2.021 - 2.024 (0.0796 - 0.0797)		White		
	LWR	2.018 - 2.021 (0.0794 - 0.0796)		Purple		

*: Always check with the Parts Department for the latest parts information.

UNDERSIZE

Unit: mm (in)

Items	Thickness	Main journal diameter
0.25 (0.0098)	2.132 - 2.140 (0.0839 - 0.0843)	Grind so that bearing clearance is the specified value.

MAIN BEARING OIL CLEARANCE

Unit: mm (in)

Items	Standard	Limit
Main bearing oil clearance	0.035 - 0.045 (0.0014 - 0.0018)*	0.065 (0.0026)

*: Actual clearance

Connecting Rod Bearing

INFOID:000000007420322

CONNECTING ROD BEARING

Unit: mm (in)

Grade number*	Thickness	Identification color (mark)
0	1.500 - 1.503 (0.0591 - 0.0592)	Black
1	1.503 - 1.506 (0.0592 - 0.0593)	Brown
2	1.506 - 1.509 (0.0593 - 0.0594)	Green

*: Always check with the Parts Department for the latest parts information.

UNDERSIZE

Unit: mm (in)

Items	Thickness	Crank pin journal diameter (Dp)
0.25 (0.0098)	1.626 - 1.634 (0.0640 - 0.0643)	Grind so that bearing clearance is the specified value.

SERVICE DATA AND SPECIFICATIONS (SDS)

< SERVICE DATA AND SPECIFICATIONS (SDS)

[VQ35DE]

CONNECTING ROD BEARING OIL CLEARANCE

Unit: mm (in)

Items	Standard	Limit
Connecting rod bearing oil clearance	0.020 - 0.045 (0.0008 - 0.0018)*	0.070 (0.0028)

*: Actual clearance

Drive Plate

INFOID:000000007420323

Unit: mm (in)

Drive plate runout [TIR]* - on torque converter mounting surface	Less than 0.35 (0.0138)
Drive plate runout [TIR]* - on ring gear	0.5 (0.0197)

*: Total indicator reading