

SECTION **INT**
INTERIOR

A
B
C
D
E
F
G
H
I
INT
K
L
M
N
O
P

CONTENTS

SEDAN		FLOOR TRIM	25
PRECAUTION	3	Exploded View	25
PRECAUTIONS	3	Removal and Installation	25
Precaution for Supplemental Restraint System (SRS) "AIR BAG" and "SEAT BELT PRE-TENSIONER"	3	HEADLINING	27
Precaution Necessary for Steering Wheel Rotation after Battery Disconnect	3	Exploded View	27
Precaution for Work	4	Removal and Installation	27
PREPARATION	5	TRUNK ROOM TRIM & TRUNK LID FINISHER	30
PREPARATION	5	Exploded View	30
Special Service Tools	5	Removal and Installation	31
Commercial Service Tools	5	COUPE	
SYMPTOM DIAGNOSIS	6	PRECAUTION	32
SQUEAK AND RATTLE TROUBLE DIAGNOSES	6	PRECAUTIONS	32
Work Flow	6	Precaution for Supplemental Restraint System (SRS) "AIR BAG" and "SEAT BELT PRE-TENSIONER"	32
Generic Squeak and Rattle Troubleshooting	8	Precaution Necessary for Steering Wheel Rotation after Battery Disconnect	32
Diagnostic Worksheet	10	Precaution for Work	33
REMOVAL AND INSTALLATION	12	PREPARATION	34
DOOR FINISHER	12	PREPARATION	34
Exploded View	12	Special Service Tools	34
Removal and Installation	13	Commercial Service Tools	34
BODY SIDE TRIM	17	SYMPTOM DIAGNOSIS	35
Exploded View	17	SQUEAK AND RATTLE TROUBLE DIAGNOSES	35
Removal and Installation	18	Work Flow	35
REAR PARCEL SHELF FINISHER	22	Generic Squeak and Rattle Troubleshooting	37
Exploded View	22	Diagnostic Worksheet	39
Removal and Installation - Rear Parcel Shelf Finisher	22	REMOVAL AND INSTALLATION	41
Removal and Installation - Child Anchor and Key Cylinder Covers	23	DOOR FINISHER	41
		Exploded View	41

Removal and Installation	41	FLOOR TRIM	49
BODY SIDE TRIM	43	Exploded View	49
Exploded View	43	Removal and Installation	49
Removal and Installation	44	HEADLINING	50
REAR PARCEL SHELF FINISHER	46	Exploded View	50
Exploded View	46	Removal and Installation	50
Removal and Installation	46	TRUNK ROOM TRIM & TRUNK LID FINISH-	
Removal and Installation - Child Anchor and Key		ER	53
Cylinder Covers	47	Exploded View	53
		Removal and Installation	54

PRECAUTION

PRECAUTIONS

Precaution for Supplemental Restraint System (SRS) "AIR BAG" and "SEAT BELT PRE-TENSIONER"

INFOID:000000007421727

The Supplemental Restraint System such as "AIR BAG" and "SEAT BELT PRE-TENSIONER", used along with a front seat belt, helps to reduce the risk or severity of injury to the driver and front passenger for certain types of collision. This system includes seat belt switch inputs and dual stage front air bag modules. The SRS system uses the seat belt switches to determine the front air bag deployment, and may only deploy one front air bag, depending on the severity of a collision and whether the front occupants are belted or unbelted. Information necessary to service the system safely is included in the SR and SB section of this Service Manual.

WARNING:

- To avoid rendering the SRS inoperative, which could increase the risk of personal injury or death in the event of a collision which would result in air bag inflation, all maintenance must be performed by an authorized NISSAN/INFINITI dealer.
- Improper maintenance, including incorrect removal and installation of the SRS, can lead to personal injury caused by unintentional activation of the system. For removal of Spiral Cable and Air Bag Module, see the SR section.
- Do not use electrical test equipment on any circuit related to the SRS unless instructed to in this Service Manual. SRS wiring harnesses can be identified by yellow and/or orange harnesses or harness connectors.

PRECAUTIONS WHEN USING POWER TOOLS (AIR OR ELECTRIC) AND HAMMERS

WARNING:

- When working near the Airbag Diagnosis Sensor Unit or other Airbag System sensors with the Ignition ON or engine running, DO NOT use air or electric power tools or strike near the sensor(s) with a hammer. Heavy vibration could activate the sensor(s) and deploy the air bag(s), possibly causing serious injury.
- When using air or electric power tools or hammers, always switch the Ignition OFF, disconnect the battery, and wait at least 3 minutes before performing any service.

Precaution Necessary for Steering Wheel Rotation after Battery Disconnect

INFOID:000000007421728

NOTE:

- Before removing and installing any control units, first turn the push-button ignition switch to the LOCK position, then disconnect both battery cables.
- After finishing work, confirm that all control unit connectors are connected properly, then re-connect both battery cables.
- Always use CONSULT to perform self-diagnosis as a part of each function inspection after finishing work. If a DTC is detected, perform trouble diagnosis according to self-diagnosis results.

This vehicle is equipped with a push-button ignition switch and a steering lock unit.

If the battery is disconnected or discharged, the steering wheel will lock and cannot be turned.

If turning the steering wheel is required with the battery disconnected or discharged, follow the procedure below before starting the repair operation.

OPERATION PROCEDURE

1. Connect both battery cables.

NOTE:

Supply power using jumper cables if battery is discharged.

2. Carry the Intelligent Key or insert it to the key slot and turn the push-button ignition switch to ACC position. (At this time, the steering lock will be released.)
3. Disconnect both battery cables. The steering lock will remain released with both battery cables disconnected and the steering wheel can be turned.
4. Perform the necessary repair operation.

A
B
C
D
E
F
G
H
I
INT
K
L
M
N
O
P

PRECAUTIONS

[SEDAN]

< PRECAUTION >

5. When the repair work is completed, re-connect both battery cables. With the brake pedal released, turn the push-button ignition switch from ACC position to ON position, then to LOCK position. (The steering wheel will lock when the push-button ignition switch is turned to LOCK position.)
6. Perform self-diagnosis check of all control units using CONSULT.

Precaution for Work

INFOID:000000007421729

- When removing or disassembling each component, be careful not to damage or deform it. If a component may be subject to interference, be sure to protect it with a shop cloth.
- When removing (disengaging) components with a screwdriver or similar tool, be sure to wrap the component with a shop cloth or vinyl tape to protect it.
- Protect the removed parts with a shop cloth and prevent them from being dropped.
- Replace a deformed or damaged clip.
- If a part is specified as a non-reusable part, always replace it with new one.
- Be sure to tighten bolts and nuts securely to the specified torque.
- After installation is complete, be sure to check that each part works properly.
- Follow the steps below to clean components.
 - Water soluble dirt: Dip a soft cloth into lukewarm water, and wring the water out of the cloth to wipe the dirty area.
Then rub with a soft and dry cloth.
 - Oily dirt: Dip a soft cloth into lukewarm water with mild detergent (concentration: within 2 to 3%), and wipe the dirty area.
Then dip a cloth into fresh water, and wring the water out of the cloth to wipe the detergent off. Then rub with a soft and dry cloth.
- Do not use organic solvent such as thinner, benzene, alcohol, or gasoline.
- For genuine leather seats, use a genuine leather seat cleaner.

PREPARATION

< PREPARATION >

[SEDAN]

PREPARATION

PREPARATION

Special Service Tools

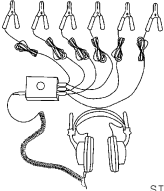
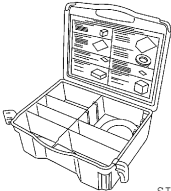
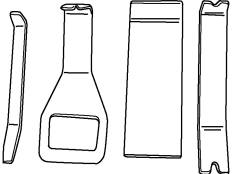

INFOID:000000007421730

The actual shapes of Kent-Moore tools may differ from those of special service tools illustrated here.

Tool number (Kent-Moore No.) Tool name	Description
— (J-39570) Chassis ear  <p style="text-align: center;">SIIA0993E</p>	Locating the noise
— (J-43980) NISSAN Squeak and Rattle Kit  <p style="text-align: center;">SIIA0994E</p>	Repairing the cause of noise
— (J-46534) Trim Tool Set  <p style="text-align: center;">AWJIA0483Z</p>	Removing trim components

Commercial Service Tools

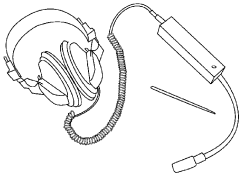
INFOID:000000007421731

Tool name	Description
Engine ear  <p style="text-align: center;">SIIA0995E</p>	Locating the noise
Power tools  <p style="text-align: center;">PIIB1407E</p>	Loosening nuts, screws and bolts

SYMPTOM DIAGNOSIS

SQUEAK AND RATTLE TROUBLE DIAGNOSES

Work Flow

INFOID:000000007421732

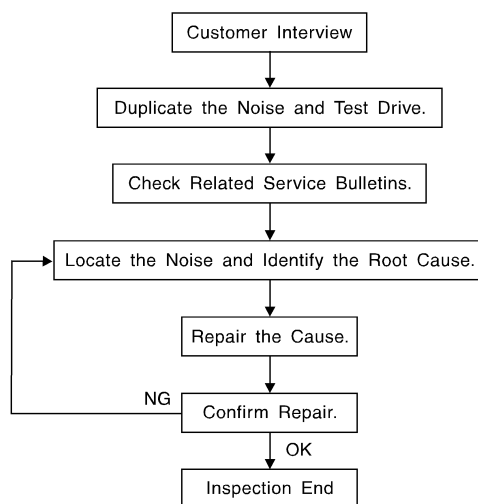

SBT842

CUSTOMER INTERVIEW

Interview the customer if possible, to determine the conditions that exist when the noise occurs. Use the Diagnostic Worksheet during the interview to document the facts and conditions when the noise occurs and any customer's comments; refer to [INT-39, "Diagnostic Worksheet"](#). This information is necessary to duplicate the conditions that exist when the noise occurs.

- The customer may not be able to provide a detailed description or the location of the noise. Attempt to obtain all the facts and conditions that exist when the noise occurs (or does not occur).
- If there is more than one noise in the vehicle, be sure to diagnose and repair the noise that the customer is concerned about. This can be accomplished by test driving the vehicle with the customer.
- After identifying the type of noise, isolate the noise in terms of its characteristics. The noise characteristics are provided so the customer, service adviser and technician are all speaking the same language when defining the noise.
- Squeak —(Like tennis shoes on a clean floor)
Squeak characteristics include the light contact/fast movement/brought on by road conditions/hard surfaces = higher pitch noise/softer surfaces = lower pitch noises/edge to surface = chirping.
- Creak—(Like walking on an old wooden floor)
Creak characteristics include firm contact/slow movement/twisting with a rotational movement/pitch dependent on materials/often brought on by activity.
- Rattle—(Like shaking a baby rattle)
Rattle characteristics include the fast repeated contact/vibration or similar movement/loose parts/missing clip or fastener/incorrect clearance.
- Knock —(Like a knock on a door)
Knock characteristics include hollow sounding/sometimes repeating/often brought on by driver action.
- Tick—(Like a clock second hand)
Tick characteristics include gentle contacting of light materials/loose components/can be caused by driver action or road conditions.
- Thump—(Heavy, muffled knock noise)
Thump characteristics include softer knock/dead sound often brought on by activity.
- Buzz—(Like a bumble bee)
Buzz characteristics include high frequency rattle/firm contact.
- Often the degree of acceptable noise level will vary depending upon the person. A noise that you may judge as acceptable may be very irritating to the customer.
- Weather conditions, especially humidity and temperature, may have a great effect on noise level.

DUPLICATE THE NOISE AND TEST DRIVE

SQUEAK AND RATTLE TROUBLE DIAGNOSES

[SEDAN]

< SYMPTOM DIAGNOSIS >

If possible, drive the vehicle with the customer until the noise is duplicated. Note any additional information on the Diagnostic Worksheet regarding the conditions or location of the noise. This information can be used to duplicate the same conditions when you confirm the repair.

If the noise can be duplicated easily during the test drive, to help identify the source of the noise, try to duplicate the noise with the vehicle stopped by doing one or all of the following:

- 1) Close a door.
 - 2) Tap or push/pull around the area where the noise appears to be coming from.
 - 3) Rev the engine.
 - 4) Use a floor jack to recreate vehicle "twist".
 - 5) At idle, apply engine load (electrical load, half-clutch on M/T model, drive position on CVT and A/T models).
 - 6) Raise the vehicle on a hoist and hit a tire with a rubber hammer.
- Drive the vehicle and attempt to duplicate the conditions the customer states exist when the noise occurs.
 - If it is difficult to duplicate the noise, drive the vehicle slowly on an undulating or rough road to stress the vehicle body.

CHECK RELATED SERVICE BULLETINS

After verifying the customer concern or symptom, check ASIST for Technical Service Bulletins (TSBs) related to that concern or symptom.

If a TSB relates to the symptom, follow the procedure to repair the noise.

LOCATE THE NOISE AND IDENTIFY THE ROOT CAUSE

1. Narrow down the noise to a general area. To help pinpoint the source of the noise, use a listening tool (Chassis Ear: J-39570, Engine Ear: J-39565 and mechanic's stethoscope).
2. Narrow down the noise to a more specific area and identify the cause of the noise by:
 - removing the components in the area that you suspect the noise is coming from.
Do not use too much force when removing clips and fasteners, otherwise clips and fasteners can be broken or lost during the repair, resulting in the creation of new noise.
 - tapping or pushing/pulling the component that you suspect is causing the noise.
Do not tap or push/pull the component with excessive force, otherwise the noise will be eliminated only temporarily.
 - feeling for a vibration with your hand by touching the component(s) that you suspect is (are) causing the noise.
 - placing a piece of paper between components that you suspect are causing the noise.
 - looking for loose components and contact marks.Refer to [INT-37, "Generic Squeak and Rattle Troubleshooting"](#).

REPAIR THE CAUSE

- If the cause is a loose component, tighten the component securely.
- If the cause is insufficient clearance between components:
 - separate components by repositioning or loosening and retightening the component, if possible.
 - insulate components with a suitable insulator such as urethane pads, foam blocks, felt cloth tape or urethane tape. A NISSAN Squeak and Rattle Kit (J-43980) is available through your authorized NISSAN Parts Department.

CAUTION:

Do not use excessive force as many components are constructed of plastic and may be damaged.

Always check with the Parts Department for the latest parts information.

The following materials are contained in the NISSAN Squeak and Rattle Kit (J-43980). Each item can be ordered separately as needed.

URETHANE PADS [1.5 mm (0.059 in) thick]

Insulates connectors, harness, etc.

76268-9E005: 100×135 mm (3.94×5.31 in)/76884-71L01: 60×85 mm (2.36×3.35 in)/76884-71L02: 15×25 mm (0.59×0.98 in)

INSULATOR (Foam blocks)

Insulates components from contact. Can be used to fill space behind a panel.

73982-9E000: 45 mm (1.77 in) thick, 50×50 mm (1.97×1.97 in)/73982-50Y00: 10 mm (0.39 in) thick, 50×50 mm (1.97×1.97 in)

INSULATOR (Light foam block)

80845-71L00: 30 mm (1.18 in) thick, 30×50 mm (1.18×1.97 in)

FELT CLOTH TAPE

Used to insulate where movement does not occur. Ideal for instrument panel applications.

68370-4B000: 15×25 mm (0.59×0.98 in) pad/68239-13E00: 5 mm (0.20 in) wide tape roll. The following materials not found in the kit can also be used to repair squeaks and rattles.

SQUEAK AND RATTLE TROUBLE DIAGNOSES

[SEDAN]

< SYMPTOM DIAGNOSIS >

UHMW (TEFLON) TAPE

Insulates where slight movement is present. Ideal for instrument panel applications.

SILICONE GREASE

Used instead of UHMW tape that will be visible or not fit.

Note: Will only last a few months.

SILICONE SPRAY

Use when grease cannot be applied.

DUCT TAPE

Use to eliminate movement.

CONFIRM THE REPAIR

Confirm that the cause of a noise is repaired by test driving the vehicle. Operate the vehicle under the same conditions as when the noise originally occurred. Refer to the notes on the Diagnostic Worksheet.

Generic Squeak and Rattle Troubleshooting

INFOID:000000007421733

Refer to Table of Contents for specific component removal and installation information.

INSTRUMENT PANEL

Most incidents are caused by contact and movement between:

1. The cluster lid A and instrument panel
2. Acrylic lens and combination meter housing
3. Instrument panel to front pillar garnish
4. Instrument panel to windshield
5. Instrument panel pins
6. Wiring harnesses behind the combination meter
7. A/C defroster duct and duct joint

These incidents can usually be located by tapping or moving the components to duplicate the noise or by pressing on the components while driving to stop the noise. Most of these incidents can be repaired by applying felt cloth tape or silicone spray (in hard to reach areas). Urethane pads can be used to insulate wiring harness.

CAUTION:

Do not use silicone spray to isolate a squeak or rattle. If you saturate the area with silicone, you will not be able to recheck the repair.

CENTER CONSOLE

Components to pay attention to include:

1. Shift selector assembly cover to finisher
2. A/C control unit and cluster lid C
3. Wiring harnesses behind audio and A/C control unit

The instrument panel repair and isolation procedures also apply to the center console.

DOORS

Pay attention to the:

1. Finisher and inner panel making a slapping noise
2. Inside handle escutcheon to door finisher
3. Wiring harnesses tapping
4. Door striker out of alignment causing a popping noise on starts and stops

Tapping or moving the components or pressing on them while driving to duplicate the conditions can isolate many of these incidents. You can usually insulate the areas with felt cloth tape or insulator foam blocks from the NISSAN Squeak and Rattle Kit (J-43980) to repair the noise.

TRUNK

Trunk noises are often caused by a loose jack or loose items put into the trunk by the owner.

In addition look for:

1. Trunk lid bumpers out of adjustment
2. Trunk lid striker out of adjustment
3. The trunk lid torsion bars knocking together

SQUEAK AND RATTLE TROUBLE DIAGNOSES

[SEDAN]

< SYMPTOM DIAGNOSIS >

4. A loose license plate or bracket

Most of these incidents can be repaired by adjusting, securing or insulating the item(s) or component(s) causing the noise.

SUNROOF/HEADLINING

Noises in the sunroof/headlining area can often be traced to one of the following:

1. Sunroof lid, rail, linkage or seals making a rattle or light knocking noise
2. Sun visor shaft shaking in the holder
3. Front or rear windshield touching headliner and squeaking

Again, pressing on the components to stop the noise while duplicating the conditions can isolate most of these incidents. Repairs usually consist of insulating with felt cloth tape.

OVERHEAD CONSOLE (FRONT AND REAR)

Overhead console noises are often caused by the console panel clips not being engaged correctly. Most of these incidents are repaired by pushing up on the console at the clip locations until the clips engage.

In addition look for:

1. Loose harness or harness connectors.
2. Front console map/reading lamp lens loose.
3. Loose screws at console attachment points.

SEATS

When isolating seat noise it's important to note the position the seat is in and the load placed on the seat when the noise is present. These conditions should be duplicated when verifying and isolating the cause of the noise.

Cause of seat noise include:

1. Headrest rods and holder
2. A squeak between the seat pad cushion and frame
3. The rear seatback lock and bracket

These noises can be isolated by moving or pressing on the suspected components while duplicating the conditions under which the noise occurs. Most of these incidents can be repaired by repositioning the component or applying urethane tape to the contact area.

UNDERHOOD

Some interior noise may be caused by components under the hood or on the engine wall. The noise is then transmitted into the passenger compartment.

Causes of transmitted underhood noise include:

1. Any component installed to the engine wall
2. Components that pass through the engine wall
3. Engine wall mounts and connectors
4. Loose radiator installation pins
5. Hood bumpers out of adjustment
6. Hood striker out of adjustment

These noises can be difficult to isolate since they cannot be reached from the interior of the vehicle. The best method is to secure, move or insulate one component at a time and test drive the vehicle. Also, engine RPM or load can be changed to isolate the noise. Repairs can usually be made by moving, adjusting, securing, or insulating the component causing the noise.

A
B
C
D
E
F
G
H
I
INT
K
L
M
N
O
P

SQUEAK AND RATTLE TROUBLE DIAGNOSES

< SYMPTOM DIAGNOSIS >

[SEDAN]

Diagnostic Worksheet

INFOID:000000007421734

Dear Customer:

We are concerned about your satisfaction with your vehicle. Repairing a squeak or rattle sometimes can be very difficult. To help us fix your vehicle right the first time, please take a moment to note the area of the vehicle where the squeak or rattle occurs and under what conditions. You may be asked to take a test drive with a service advisor or technician to ensure we confirm the noise you are hearing.

SQUEAK & RATTLE DIAGNOSTIC WORKSHEET

I. WHERE DOES THE NOISE COME FROM? (circle the area of the vehicle)

The illustrations are for reference only, and may not reflect the actual configuration of your vehicle.

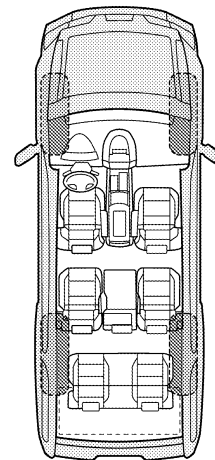
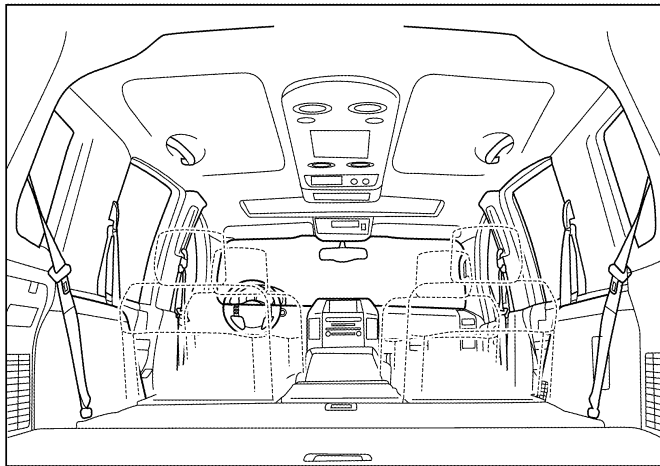
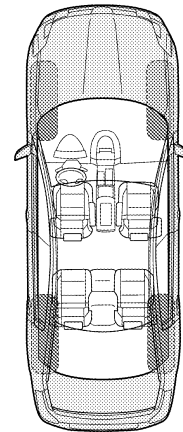
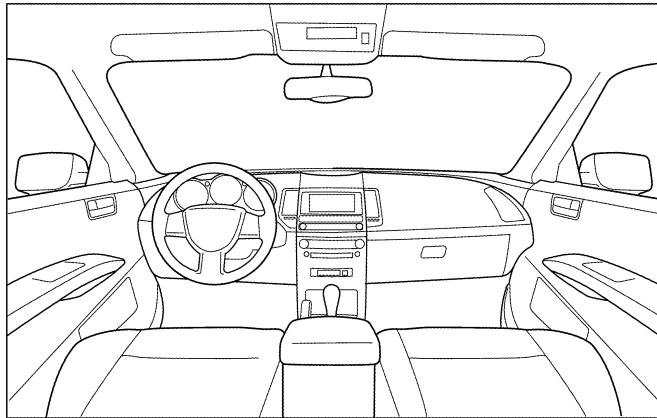

Continue to page 2 of the worksheet and briefly describe the location of the noise or rattle. In addition, please indicate the conditions which are present when the noise occurs.

SQUEAK AND RATTLE TROUBLE DIAGNOSES

< SYMPTOM DIAGNOSIS >

[SEDAN]

SQUEAK & RATTLE DIAGNOSTIC WORKSHEET - page 2

Briefly describe the location where the noise occurs:

II. WHEN DOES IT OCCUR? (please check the boxes that apply)

- | | |
|---|--|
| <input type="checkbox"/> Anytime | <input type="checkbox"/> After sitting out in the rain |
| <input type="checkbox"/> 1st time in the morning | <input type="checkbox"/> When it is raining or wet |
| <input type="checkbox"/> Only when it is cold outside | <input type="checkbox"/> Dry or dusty conditions |
| <input type="checkbox"/> Only when it is hot outside | <input type="checkbox"/> Other: |

III. WHEN DRIVING:

- Through driveways
- Over rough roads
- Over speed bumps
- Only about ____ mph
- On acceleration
- Coming to a stop
- On turns: left, right or either (circle)
- With passengers or cargo
- Other: _____
- After driving ____ miles or ____ minutes

IV. WHAT TYPE OF NOISE

- Squeak (like tennis shoes on a clean floor)
- Creak (like walking on an old wooden floor)
- Rattle (like shaking a baby rattle)
- Knock (like a knock at the door)
- Tick (like a clock second hand)
- Thump (heavy muffled knock noise)
- Buzz (like a bumble bee)

TO BE COMPLETED BY DEALERSHIP PERSONNEL

Test Drive Notes:

	YES	NO	Initials of person performing
Vehicle test driven with customer	<input type="checkbox"/>	<input type="checkbox"/>	_____
- Noise verified on test drive	<input type="checkbox"/>	<input type="checkbox"/>	_____
- Noise source located and repaired	<input type="checkbox"/>	<input type="checkbox"/>	_____
- Follow up test drive performed to confirm repair	<input type="checkbox"/>	<input type="checkbox"/>	_____

VIN: _____ Customer Name _____

W.O.# _____ Date: _____

This form must be attached to Work Order

LATA0071E

A
B
C
D
E
F
G
H
I
INT
K
L
M
N
O
P

DOOR FINISHER

< REMOVAL AND INSTALLATION >

[SEDAN]

REMOVAL AND INSTALLATION

DOOR FINISHER

Exploded View

INFOID:000000007421735

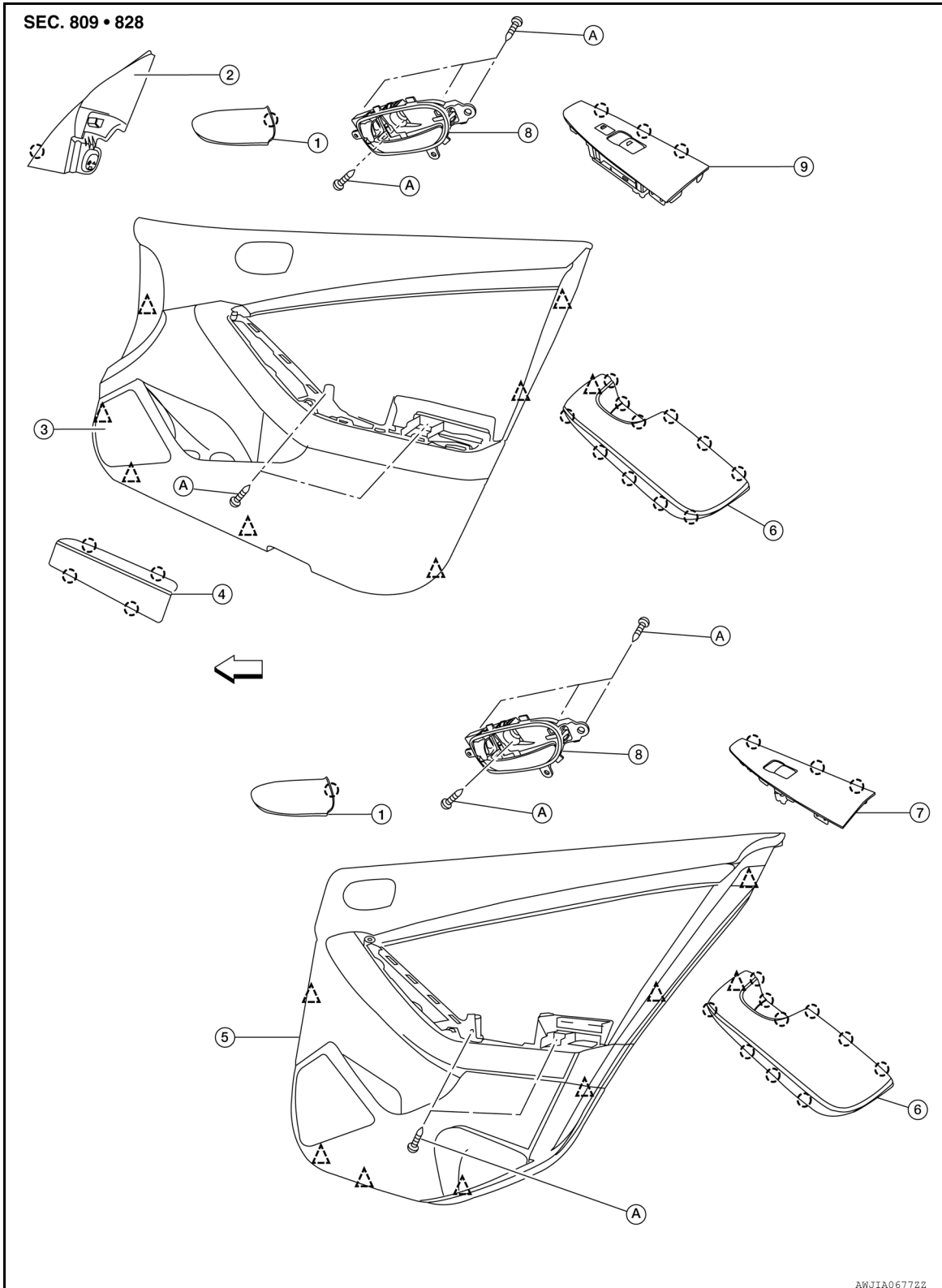



AWJIA0677ZZ

- | | | |
|--------------------------------------|--------------------------|---|
| 1. Inside release handle escutcheon | 2. Mirror cover | 3. Front door finisher |
| 4. Front step lamp lens | 5. Rear door finisher | 6. Armrest finisher |
| 7. Rear power window switch finisher | 8. Inside release handle | 9. Front power window/door lock switch finisher |

A. Screw

 Clip C101

 Pawl

 Vehicle front

Removal and Installation

INFOID:000000007421736

FRONT DOOR FINISHER

Removal

1. Remove the front step lamp. Refer to [INL-108, "Removal and Installation"](#).
2. Release the pawl at the rear edge and remove inside release handle escutcheon, then remove the screw.
3. Remove the armrest finisher as follows:

CAUTION:

If not removed properly, the door armrest finisher clips may be damaged: making it hard to properly reinstall the part.

- a. Insert a suitable tool and twist, while gently lifting up at rear of armrest finisher to release the four outboard pawls (A).

 Pawl

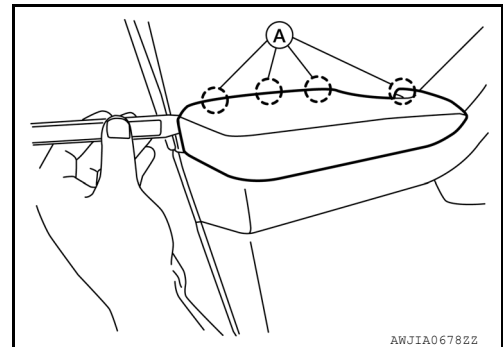

- b. Gently lift up on the rear of the armrest finisher to release the inboard pawls (B).

 Pawl

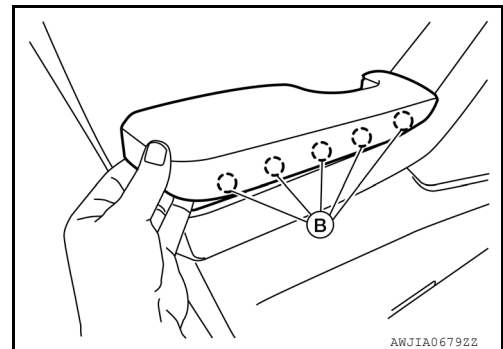

- c. Support the armrest finisher at the pull grip part of the armrest finisher while gently lifting the armrest finisher straight up to release the pull grip pawls and clip (C), then remove the armrest finisher (1).

 Clip

CAUTION:

Do not twist, pull the armrest straight up to remove.

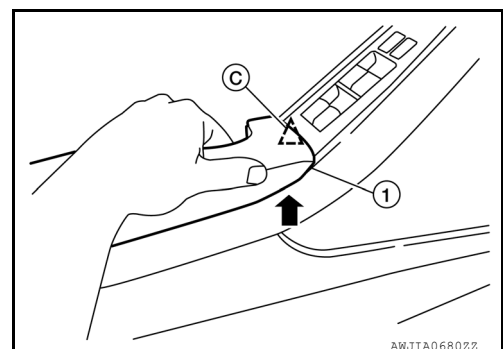

4. Remove the main power window/door lock switch finisher (LH) or front power window/door lock switch finisher (RH). Refer to [PWC-98, "Removal and Installation"](#) (Main LH Only Window Anti-Pinch), [PWC-98, "Removal and Installation"](#) (Main LH - LH & RH Front Window Anti-Pinch), [PWC-193, "Removal and Installation"](#)

A
B
C
D
E
F
G
H
I
INT
K
L
M
N
O
P

DOOR FINISHER

[SEDAN]

< REMOVAL AND INSTALLATION >

[Installation](#) (Front RH - LH Only Window Anti-Pinch) or [PWC-299. "Removal and Installation"](#) (Front RH - LH & RH Front Window Anti-Pinch).

5. Remove the front door finisher screws beneath the arm rest finisher and the main or front power window/door lock switch finisher.
6. Release the clips around outer edge, then reposition the front door finisher.
7. Disconnect inside release handle and lock knob cables from back of front door finisher, then remove front door finisher.

Installation

1. Connect the inside release handle and lock knob cables to the back of the front door finisher.
2. Align the front door finisher clips around the outer edge, then install the front door finisher.
3. Install the front door finisher screws beneath arm rest finisher and the main or front power window/door lock switch finisher.
4. Connect the door lock/unlock switch connector and install the main or front power window/door lock switch finisher.
5. Install the armrest finisher as follows:
 - a. Align and press the armrest finisher clip (D) and pawl (B), into the front door finisher.

- △: Clip
○: Pawl

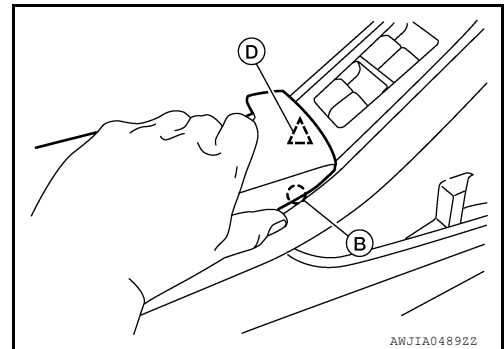

- b. Align and press out and down to seat the pull grip pawls and the inboard pawls.

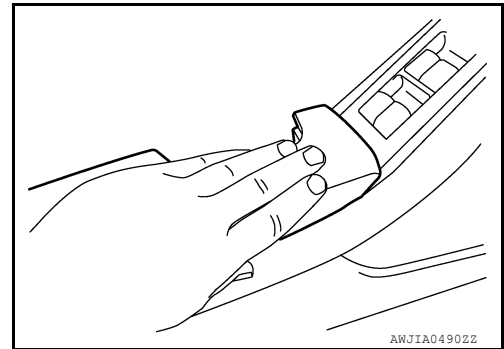

- c. Align and press down to seat the outboard pawls.

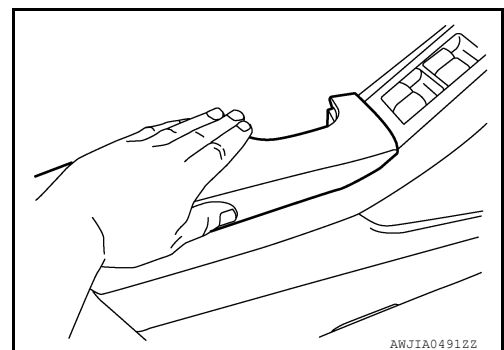

6. Install the screw, then align the inside release handle escutcheon pawl, and install the inside release handle escutcheon.
7. Install the front step lamp. Refer to [INL-108. "Removal and Installation"](#).

REAR DOOR FINISHER

Removal

DOOR FINISHER

< REMOVAL AND INSTALLATION >

[SEDAN]

1. Release the pawl at the rear edge and remove inside release handle escutcheon, then remove the screw.
2. Remove the armrest finisher as follows:

CAUTION:

If not removed properly, the door armrest finisher clips may be damaged: making it hard to properly reinstall the part.

- a. Insert a suitable tool and twist, gently lifting up at rear of armrest finisher to release outboard pawls (A).

○: Pawl

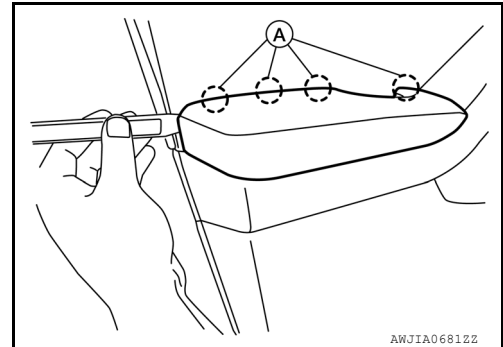

- b. Gently lift up on the rear of the armrest finisher to release the inboard pawls (B).

○: Pawl

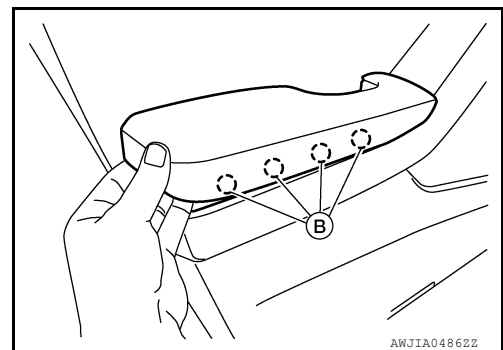

- c. Support the armrest finisher at the pull grip part of the armrest finisher while gently lifting the armrest finisher straight up to release the pull grip pawls and clip (C), then remove the armrest finisher (1).

△: Clip

CAUTION:

Do not twist, pull the armrest straight up to remove.

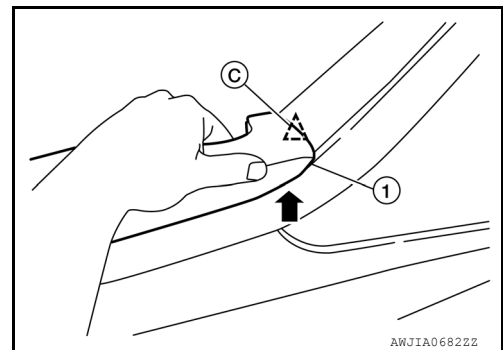

3. Remove the rear power window switch finisher. Refer to [PWC-100, "Removal and Installation"](#).
4. Remove the rear door finisher screws beneath the arm rest finisher and the rear power window switch finisher.
5. Release the clips around outer edge, then reposition the rear door finisher.
6. Disconnect inside release handle and lock knob cables from the back of rear door finisher, then remove rear door finisher.

Installation

Installation is in the reverse order of removal.

NOTE:

When installing the armrest finisher, perform the following:

A
B
C
D
E
F
G
H
I
INT
K
L
M
N
O
P

DOOR FINISHER

< REMOVAL AND INSTALLATION >

[SEDAN]

1. Align and press the armrest finisher clip (D) and pawl (B), into the front door finisher.

△: Clip
○: Pawl

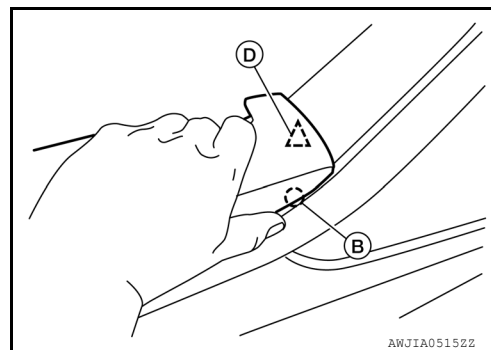

2. Align and press out and down to seat the pull grip pawls and the inboard pawls.

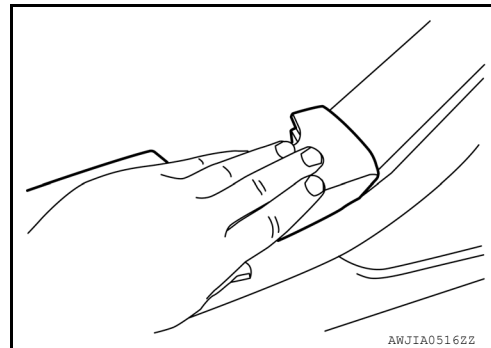

3. Align and press down to seat the outboard pawls.

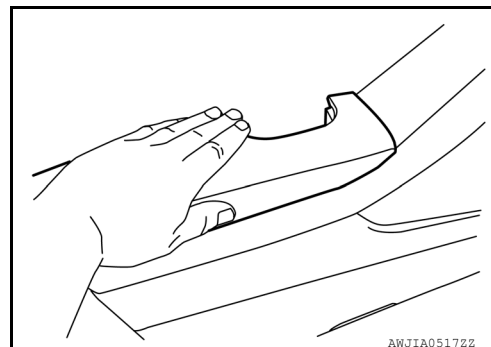

BODY SIDE TRIM

< REMOVAL AND INSTALLATION >

[SEDAN]

BODY SIDE TRIM

Exploded View

INFOID:000000007421737

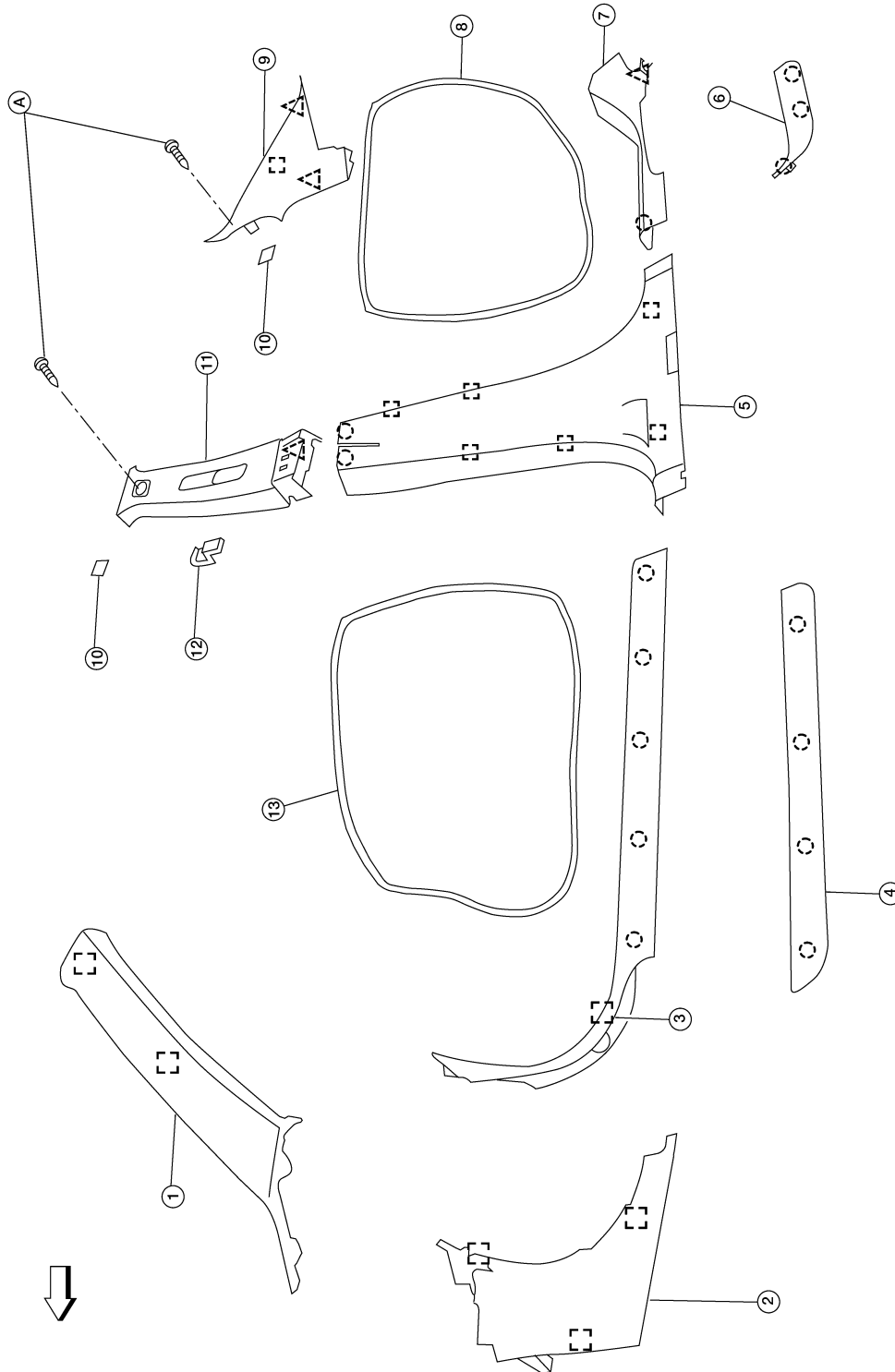

A
B
C
D
E
F
G
H
I
INT
K
L
M
N
O
P

SEC. 769

AWJIA05632Z

- 1. Front pillar finisher
- 4. Front sill plate cover
- 7. Rear kicking plate

- 2. Dash side lower finisher
- 5. Center pillar lower finisher
- 8. Rear body side welt

- 3. Front kicking plate
- 6. Rear sill plate cover
- 9. Rear pillar finisher

BODY SIDE TRIM

[SEDAN]

< REMOVAL AND INSTALLATION >

- 10. Screw cover
- 13. Front body side welt



Pawl

- 11. Center pillar upper finisher
- A. Screw



Metal clip

- 12. Front seat belt adjuster cover



Clip C101

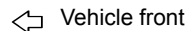

Vehicle front

Removal and Installation

INFOID:000000007421738

CAUTION:

- Wrap the tip of a suitable tool with a cloth when removing clips or finishers.
- When removing always use suitable tools made of plastic.
- When removing or installing body side welts, do not allow butyl seal to come in contact with pillar finishers.
- Make sure that clips are fully aligned with panel holes on body when installing, then press them in completely.

FRONT PILLAR FINISHER

Removal

1. Partially remove front body side welt.

CAUTION:

The front pillar finisher lower clip will not completely detach. Attempting to completely detaching it by force will damage the front pillar finisher.

2. Release the front pillar finisher (1) upper and lower clips by carefully prying inward while, using a suitable tool (A).



Metal clip

CAUTION:
The lower clip will not completely release. Attempting to completely release by force may damage the finisher.

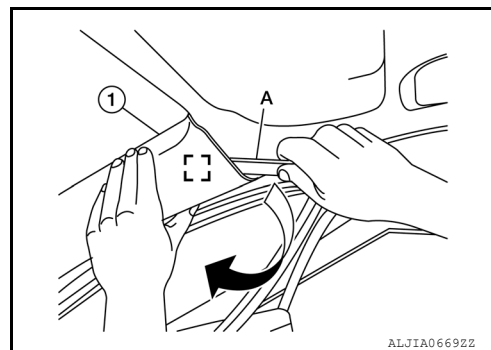

ALJIA06692Z

3. Detach the front pillar finisher (1) lower clip (A) from the front pillar finisher (1), using a suitable tool (B).

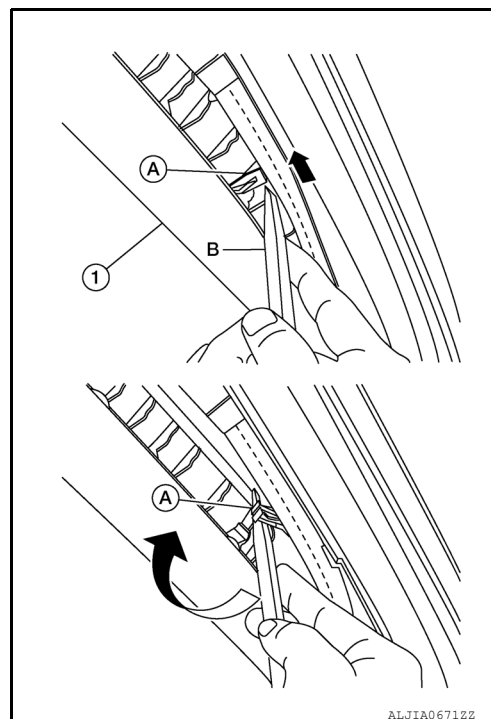

ALJIA06712Z

BODY SIDE TRIM

< REMOVAL AND INSTALLATION >

[SEDAN]

4. Tilt the top of the front pillar finisher inward, and then pull out to remove from the vehicle.

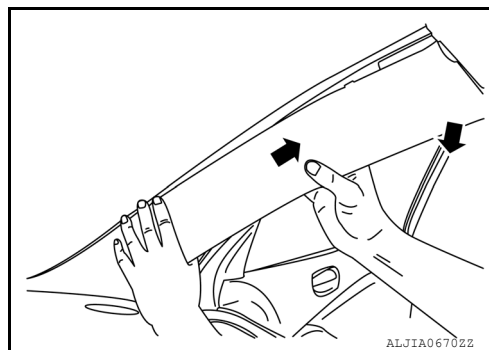

5. Remove the front pillar finisher lower clip (A) from the front pillar by pinching, then tilting upward and removing from the front pillar.

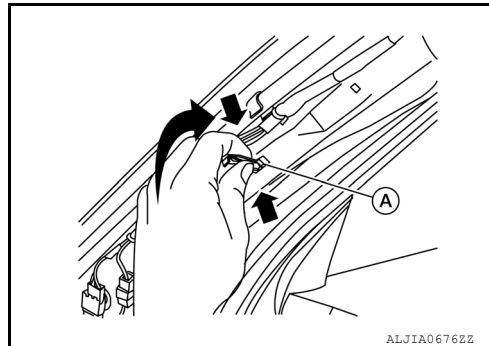

Installation

1. Insert the front pillar finisher lower clip (A), onto the front pillar finisher (1) by sliding into the slot.

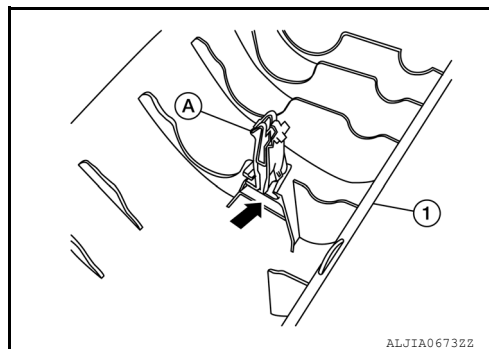

A
B
C
D
E
F
G
H
I
INT
K
L
M
N
O
P

BODY SIDE TRIM

< REMOVAL AND INSTALLATION >

[SEDAN]

2. Position the front pillar finisher (1) at the bottom of the front pillar, then align the locator tabs into the tweeter speaker grille slot and the instrument panel slot.

 Metal clip

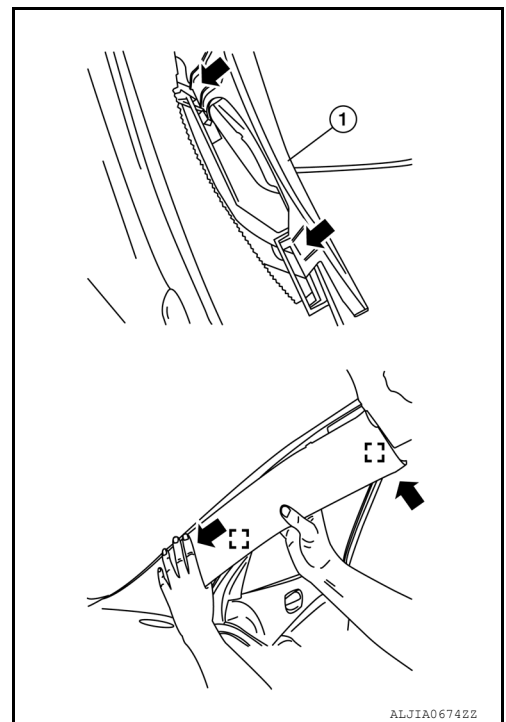

3. Align the front pillar finisher (1) lower clip (B) and upper clip (A) into their slots, then press into place, while installing the front pillar finisher (1).

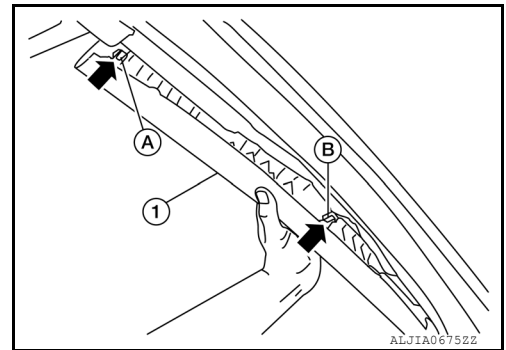

4. Install the front body side welt.

DASH SIDE LOWER FINISHER

Removal

1. Remove front kicking plate.
2. Release the clips, then remove dash side lower finisher.

Installation

Installation is in the reverse order of removal.

FRONT KICKING PLATE

Removal

Release the clip and pawls, then remove front kicking plate.

Installation

Installation is in the reverse order of removal.

FRONT BODY SIDE WELT

Removal

1. Remove front kicking plate.
2. Release front body side welt from the body opening, then remove front body side welt.

Installation

BODY SIDE TRIM

[SEDAN]

< REMOVAL AND INSTALLATION >

Installation is in the reverse order of removal.

CENTER PILLAR LOWER FINISHER

Removal

1. Release the clip and pawl(s), then remove front and rear kicking plates.
2. Partially remove front and rear body side welts.
3. Release the clips and pawls, then remove center pillar lower finisher.

Installation

Installation is in the reverse order of removal.

REAR PILLAR FINISHER

Removal

1. Partially remove rear body side welt.
2. Remove screw cover, then remove the screw.
3. Release the clips, then remove rear pillar finisher.

Installation

Installation is in the reverse order of removal.

CENTER PILLAR UPPER FINISHER

Removal

1. Release the clip and pawl(s), then remove front and rear kicking plates.
2. Partially remove front and rear body side welts.
3. Remove screw cover, then remove the screw.
4. Remove front seat belt adjuster cover and shoulder anchor bolt. Refer to [SB-8. "Removal and Installation"](#).
5. Release clips and pawls, then remove center pillar lower finisher.
6. Release the clips, then remove center pillar upper finisher.

Installation

Installation is in the reverse order of removal.

REAR KICKING PLATE

Removal

Release the clip and pawl, then remove rear kicking plate.

Installation

Installation is in the reverse order of removal.

REAR BODY SIDE WELT

Removal

1. Release the clip and pawl, then remove rear kicking plate.
2. Release the welt from the body opening, then remove rear body side welt.

Installation

Installation is in the reverse order of removal.

SILL PLATE COVER (FRONT/REAR)

Removal

Release the pawls, then remove the sill plate cover.

Installation

Installation is in the reverse order of removal.

A

B

C

D

E

F

G

H

I

INT

K

L

M

N

O

P

REAR PARCEL SHELF FINISHER

< REMOVAL AND INSTALLATION >

[SEDAN]

REAR PARCEL SHELF FINISHER

Exploded View

INFOID:000000007421739

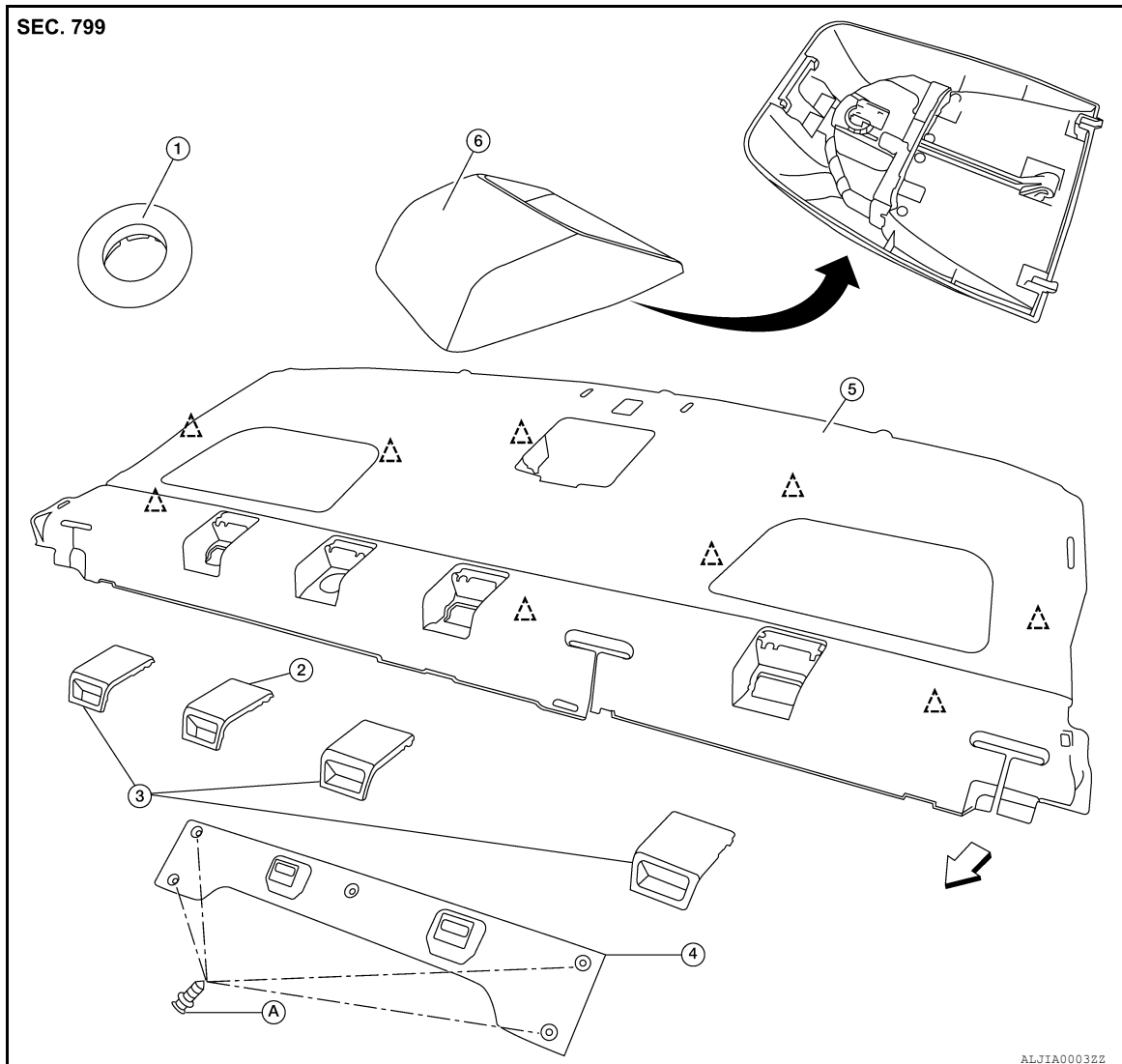

- | | | |
|--------------------------------|-------------------------------|---|
| 1. Seatback release escutcheon | 2. Key cylinder cover | 3. Child anchor cover |
| 4. Seatback latch cover | 5. Rear parcel shelf finisher | 6. High mounted stop lamp (if equipped) |
| A. Clip C205 | △ Clip C101 | ⇐ Vehicle front |

Removal and Installation - Rear Parcel Shelf Finisher

INFOID:000000007421740

REMOVAL

1. Release seatback latches (RH/LH), then fold both rear seatbacks to forward most position.
2. Release the clips, then remove seatback latch cover.
3. Remove the key cylinder cover and child anchor covers from the rear parcel shelf finisher. Refer to [INT-23. "Removal and Installation - Child Anchor and Key Cylinder Covers"](#).
4. Remove high mounted stop lamp, (if equipped). Refer to [EXL-214. "Removal and Installation"](#).
5. Remove rear pillar finishers (RH/LH). Refer to [INT-18. "Removal and Installation"](#).
6. Thread the rear seat belts (RH/LH/Center) through vertical opening and release from rear parcel shelf finisher.
7. Using a suitable tool, release the clips, then remove rear parcel shelf finisher.

REAR PARCEL SHELF FINISHER

[SEDAN]

< REMOVAL AND INSTALLATION >

INSTALLATION

Installation is in the reverse order of removal.

CAUTION:

Make sure that clips are fully aligned with panel holes on body when installing, then press them in completely.

Removal and Installation - Child Anchor and Key Cylinder Covers

INFOID:000000007421741

REMOVAL

1. Lift the child anchor cover or key cylinder cover to a full open position.

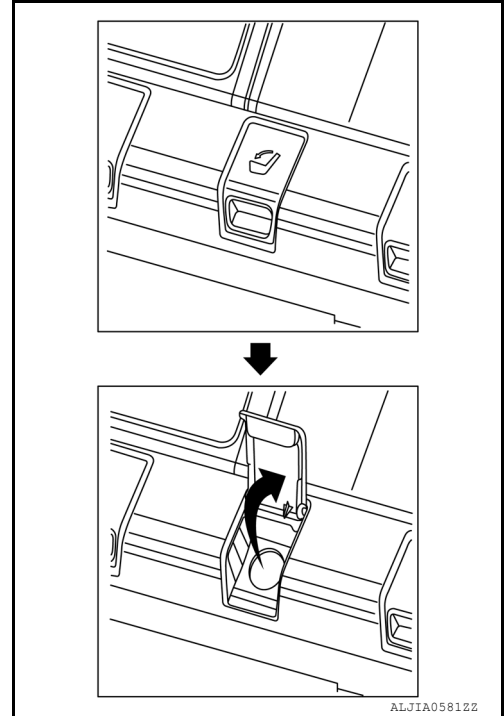

2. Rotate the child anchor cover or key cylinder cover as shown to disengage the left hinge (A) of the cover from the left retaining pin, then slide cover slightly back to the left to remove the right hinge (B) from the right retaining pin.

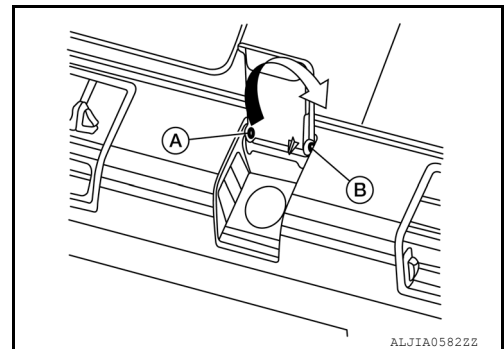

INSTALLATION

1. Install the child anchor cover or key cylinder cover by gently sliding the right hinge (A) of the child anchor cover or key cylinder cover onto the right retaining pin (B).

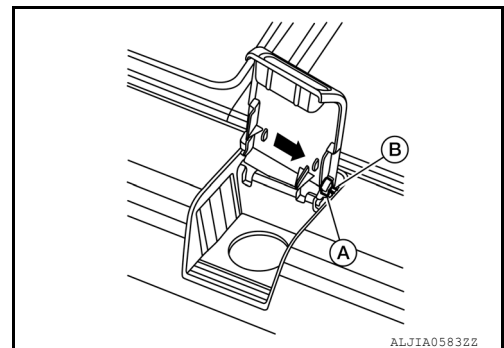

A
B
C
D
E
F
G
H
I

INT

K
L
M
N
O
P

REAR PARCEL SHELF FINISHER

[SEDAN]

< REMOVAL AND INSTALLATION >

2. Gently push down on the child anchor cover or key cylinder cover left hinge (A) to engage it to the left retaining pin (B). A snapping sound will be heard once the hinge and the retaining pin are locked together.

CAUTION:

Make sure the left hinge is completely aligned with the left retaining pin. If the two items are not aligned, and the cover is forced it may result in the breaking of the retaining pin and the rear parcel shelf finisher needing to be replaced.

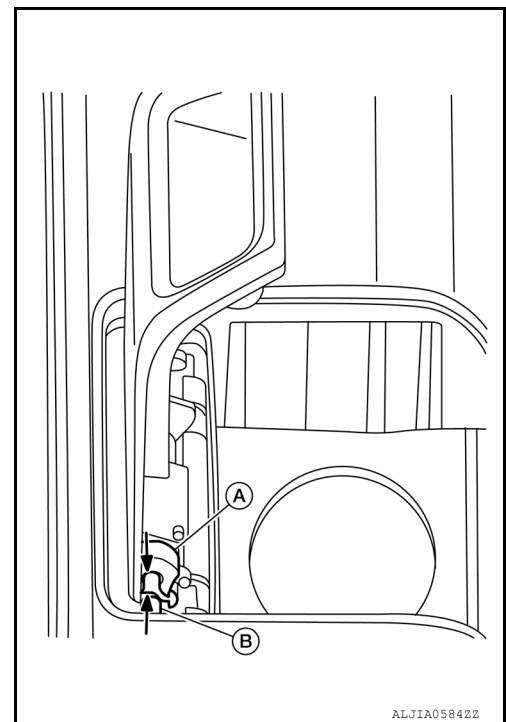

3. Lower the child anchor cover or key cylinder cover to the fully closed position.

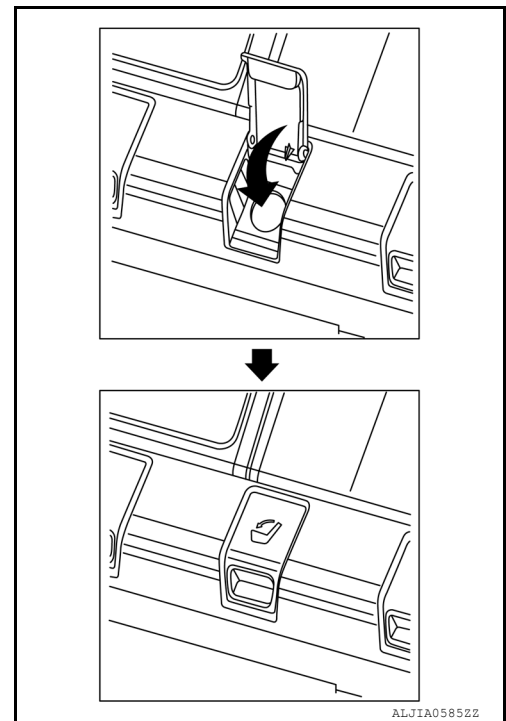

FLOOR TRIM

< REMOVAL AND INSTALLATION >

[SEDAN]

FLOOR TRIM

Exploded View

INFOID:000000007421742

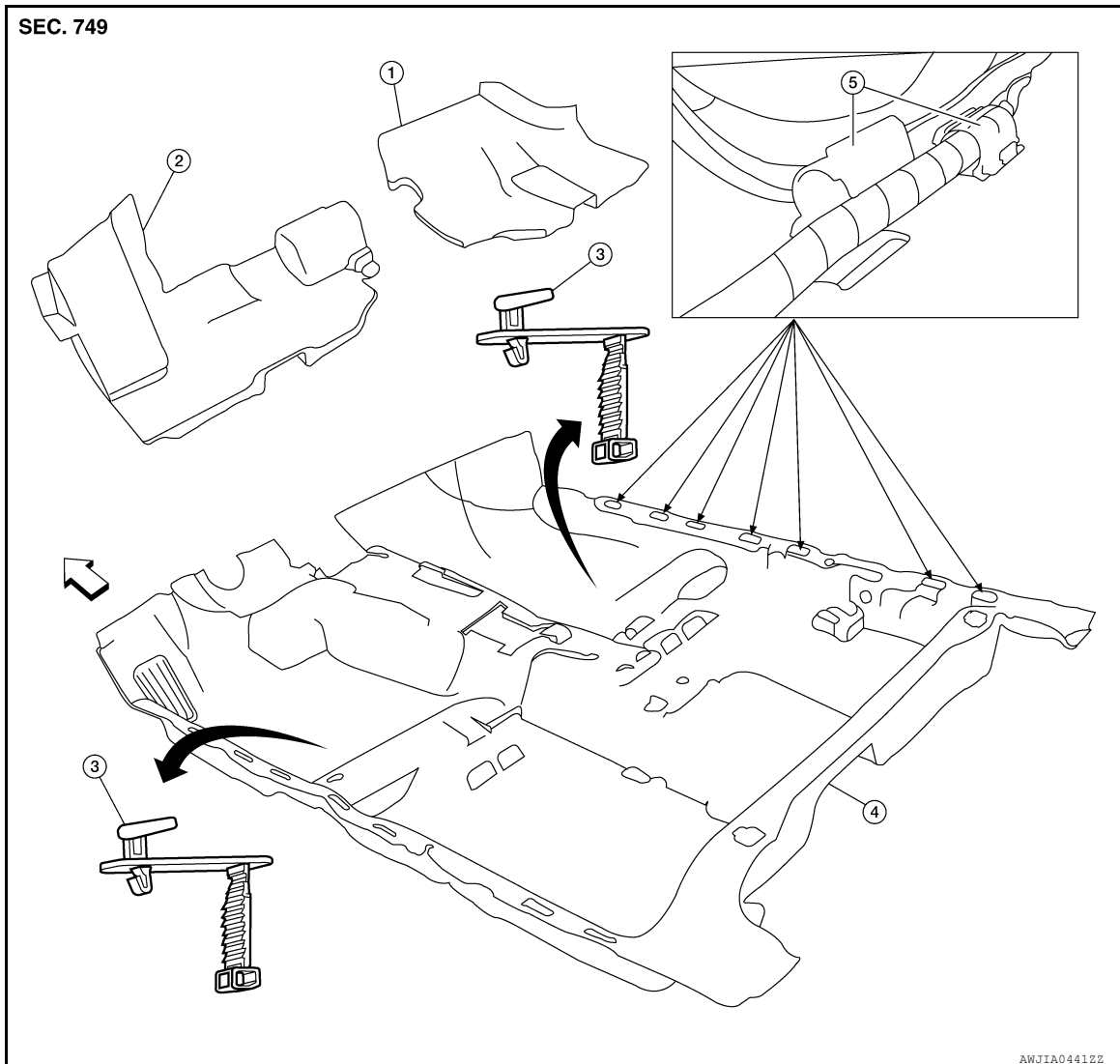

- | | | |
|-----------------|------------------|-------------------|
| 1. Spacer (RH) | 2. Spacer (LH) | 3. Floor mat hook |
| 4. Floor carpet | 5. Harness clamp | ⇐ Vehicle front |

Removal and Installation

INFOID:000000007421743

REMOVAL

1. Remove front seats (RH/LH) and rear seat cushion. Refer to [SE-66, "Removal and Installation - Seat Assembly"](#) and [SE-73, "Removal and Installation"](#).
2. Remove front kicking plates (RH/LH), dash side lower finishers (RH/LH), rear kicking plates (RH/LH), and center pillar lower finishers (RH/LH). Refer to [INT-18, "Removal and Installation"](#).
3. Remove center console. Refer to [IP-20, "Removal and Installation"](#).
4. Remove the glove box assembly. Refer to [IP-19, "Removal and Installation"](#).

FLOOR TRIM

[SEDAN]

< REMOVAL AND INSTALLATION >

5. Remove the connector ducts (RH/LH) (2) and the center connector duct (1) from heater and cooling unit. Refer to [VTL-24. "DUCTS, NOZZLES AND GRILLES : Components"](#).
 - ⇐ Vehicle front
6. Remove the bracket bolt, then position the parking brake cable aside.
7. Disconnect the drain hose (4) from the heater and cooling unit, then set aside.
8. Remove the three bolts (A) and one nut, then remove the bracket (3).
9. Remove the driver air bag module. Refer to [SR-5. "Removal and Installation"](#).
10. Disconnect the passenger air bag module. Refer to [SR-10. "Removal and Installation"](#).
11. Disconnect the side curtain air bag modules. Refer to [SR-12. "Removal and Installation"](#).
12. Remove the diagnosis sensor unit. Refer to [SR-20. "Removal and Installation"](#).
13. Remove the parking brake cable nuts (A), then position the parking brake cables (2) aside.
 - ⇐ Vehicle front
14. Remove the bracket nuts (B), then remove extension bracket (1) and center console rear bracket (3).

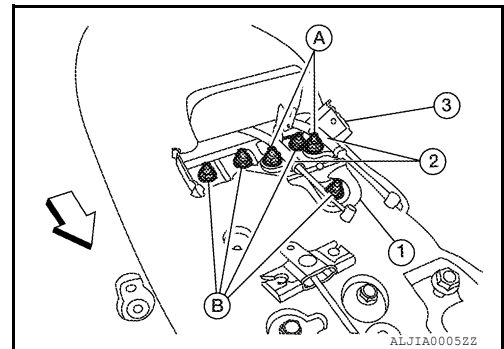
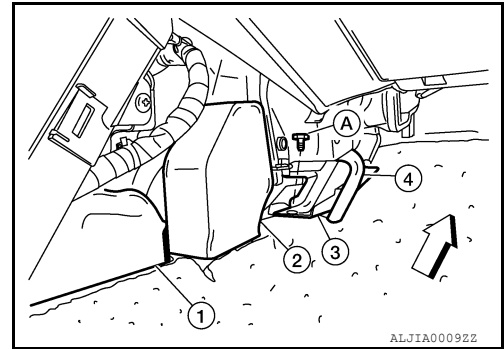

15. Remove front seat belt floor anchor bolt (RH/LH). Refer to [SB-7. "Exploded View"](#).
16. Release the tab, then remove floor mat hooks.
17. Release the tabs and open harness clamps (seven-RH and seven-LH). Position harness and floor carpet cut-out areas outside of harness clamps.
18. Fold corners toward center, then remove floor carpet.

INSTALLATION

Installation is in the reverse order of removal.

HEADLINING

< REMOVAL AND INSTALLATION >

[SEDAN]

HEADLINING

Exploded View

INFOID:000000007421744

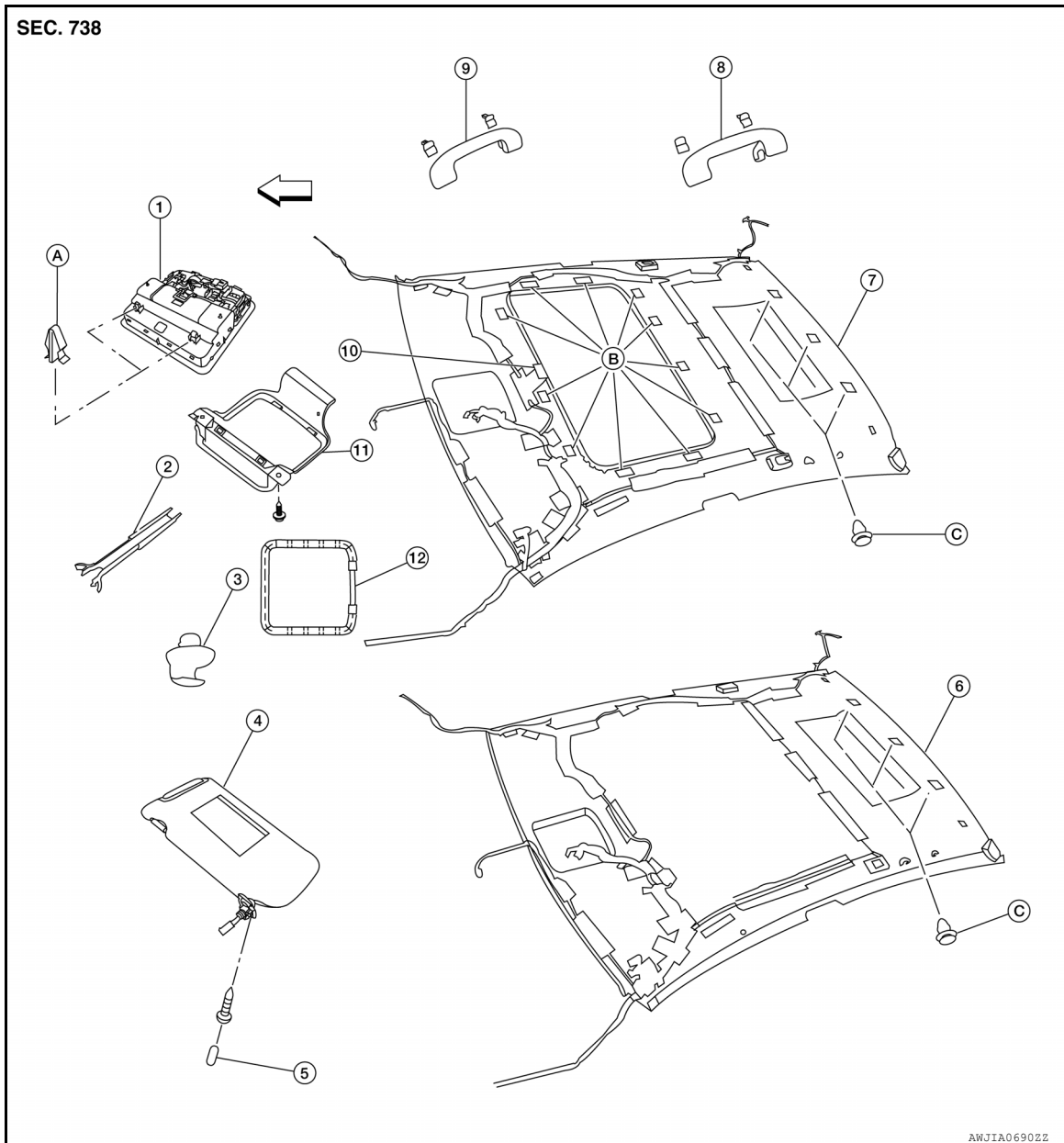

- | | | |
|---------------------------------------|---|--|
| 1. Front room/map lamp assembly | 2. Mirror harness cover | 3. Sunvisor holder |
| 4. Sunvisor | 5. Sunvisor cover | 6. Headlining assembly (without sunroof) |
| 7. Headlining assembly (with sunroof) | 8. Rear assist grip | 9. Front assist grip |
| 10. Sunroof clip | 11. Front room/map lamp bracket (All except sedan models without sunroof) | 12. Front room/map lamp bracket (Sedan models without sunroof) |
| A. Metal clip | B. Dual lock fastener | C. Clip C101 |
- ← Vehicle front

Removal and Installation

INFOID:000000007421745

CAUTION:

- Disconnect the negative and positive battery terminals and wait at least 3 minutes.
- Be careful not to bend headlining during removal or installation.

A
B
C
D
E
F
G
H
I
INT
K
L
M
N
O
P

HEADLINING

[SEDAN]

< REMOVAL AND INSTALLATION >

NOTE:

The following components are integral to the headliner and are repaired only as an assembly:

- Roof harness assembly.
- Antenna feeder assembly.

REMOVAL

1. Recline the front seats to the fully reclined position.
2. Disconnect the negative and positive battery terminals.
3. Remove front pillar finishers (RH/LH). Refer to [INT-18. "Removal and Installation"](#).
4. Disconnect headlining harness and antenna feeder connectors.
5. Remove center pillar upper and rear pillar finishers (RH/LH). Refer to [INT-18. "Removal and Installation"](#).
6. Disconnect antenna amplifier and rear window defogger connectors.
7. Release the molded clip, then remove front and rear assist grips.

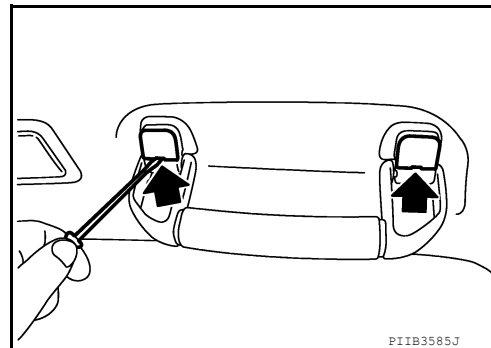

8. Disconnect rear view mirror harness connector.
9. Remove the sunvisors (RH/LH).
 - a. Remove the sunvisor covers and screws.
 - b. Disconnect the connector and remove each of the sunvisors.
10. Insert a suitable thin tool (A) at approximately a 30 degree angle into the sunvisor holder notch on the front of the sunvisor holder (1) and press in the locking tab (B) to release it. While holding in lock tab (B), turn the sunvisor holder (1) 90 degrees to release it from the headliner.
 - If the sunvisor holder (1) does not fully rotate, make sure that the suitable thin tool (A) is pressing in on the locking tab (B) and is not positioned under locking tab (B). Reinsert the suitable thin tool (A) as necessary to release the locking tab (B).

• ←: Front

CAUTION:

Do not force the sunvisor holder when removing as the locking tab may be damaged if the suitable thin tool is not positioned correctly.

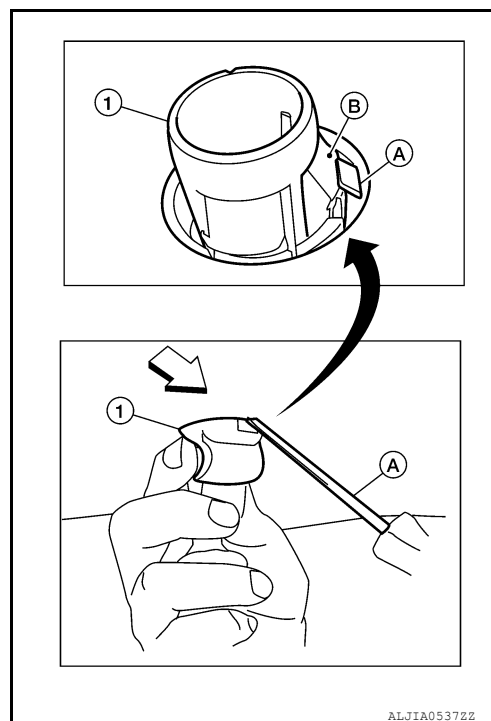

11. Remove front room/map lamp assembly. Refer to [INL-108. "Removal and Installation"](#).
 - Release the pawls and lower front room/map lamp assembly away from headliner. Disconnect the front room/map lamp and sunroof switch connectors, then remove the front room/map lamp assembly.
12. Remove the personal lamp RH/LH. Refer to [INL-108. "Removal and Installation"](#).

HEADLINING

[SEDAN]

< REMOVAL AND INSTALLATION >

13. Release dual lock fastener around the sunroof opening and release the sunroof clip using a suitable tool, if equipped.
14. Release the three hidden clips near the rear edge of headliner using a suitable clip removal tool.
15. Drop headlining down and carefully rotate into position. Remove headlining through rear door opening.

CAUTION:

- When removing, two workers (one for front and one for rear of headlining) are required.
- Cover center console finisher upper surface with a shop cloth to prevent damage.

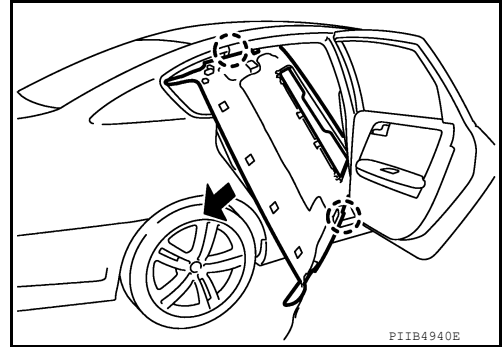

INSTALLATION

Installation is in the reverse order of removal.

A
B
C
D
E
F
G
H
I
K
L
M
N
O
P

INT

TRUNK ROOM TRIM & TRUNK LID FINISHER

< REMOVAL AND INSTALLATION >

[SEDAN]

TRUNK ROOM TRIM & TRUNK LID FINISHER

Exploded View

INFOID:000000007421746

TRUNK ROOM TRIM

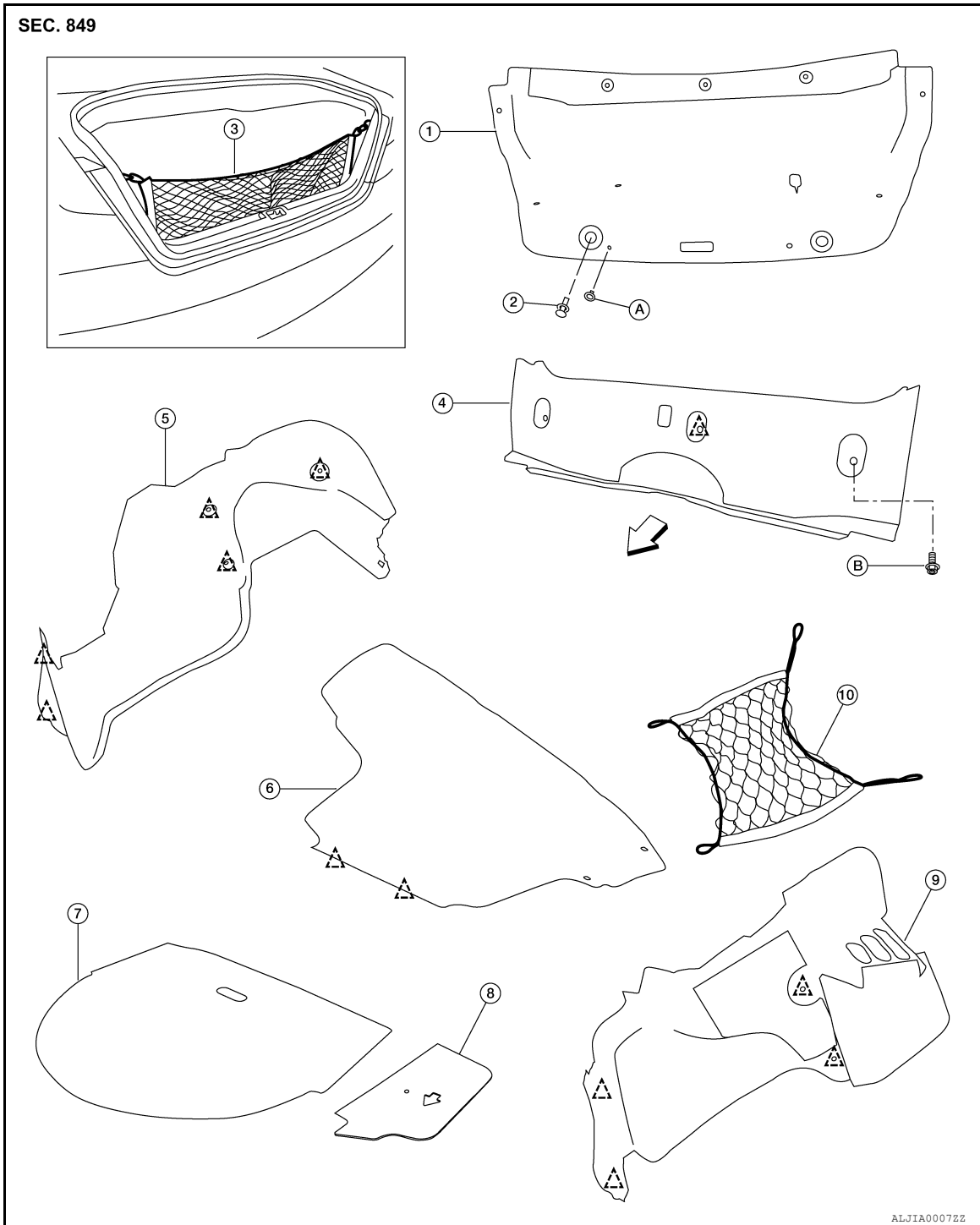

- | | | |
|------------------------|-----------------------------|-----------------------------|
| 1. Trunk lid finisher | 2. Trunk lid rubber bumper | 3. Trunk net rear |
| 4. Trunk rear finisher | 5. Trunk side finisher (RH) | 6. Trunk floor carpet |
| 7. Spare tire cover | 8. Trunk floor board (LH) | 9. Trunk side finisher (LH) |
| 10. Trunk net side | A. Clip C205 | B. Clip - hook type |
| Clip | Vehicle front | |

TRUNK ROOM TRIM & TRUNK LID FINISHER

< REMOVAL AND INSTALLATION >

[SEDAN]

Removal and Installation

INFOID:000000007421747

REMOVAL

1. Release the latch, then position rear seatbacks (RH/LH) to the folded down position.
2. Remove the rear seatback trim panel. Refer to [SE-73, "Removal and Installation"](#).
3. Release the clips, then remove trunk floor carpet.
4. Remove trunk net rear and trunk net side (if installed).
5. Release the clips, then remove trunk rear finisher.
6. Release the clips, then remove trunk side finishers (RH/LH).
7. Remove spare tire cover and trunk floor board (LH).
8. Remove the trunk lid rubber bumpers (RH/LH), then release the clips and remove trunk lid finisher.

INSTALLATION

Installation is in the reverse order of removal.

A

B

C

D

E

F

G

H

I

INT

K

L

M

N

O

P

PRECAUTION

PRECAUTIONS

Precaution for Supplemental Restraint System (SRS) "AIR BAG" and "SEAT BELT PRE-TENSIONER"

INFOID:000000007421748

The Supplemental Restraint System such as "AIR BAG" and "SEAT BELT PRE-TENSIONER", used along with a front seat belt, helps to reduce the risk or severity of injury to the driver and front passenger for certain types of collision. This system includes seat belt switch inputs and dual stage front air bag modules. The SRS system uses the seat belt switches to determine the front air bag deployment, and may only deploy one front air bag, depending on the severity of a collision and whether the front occupants are belted or unbelted. Information necessary to service the system safely is included in the SR and SB section of this Service Manual.

WARNING:

- To avoid rendering the SRS inoperative, which could increase the risk of personal injury or death in the event of a collision which would result in air bag inflation, all maintenance must be performed by an authorized NISSAN/INFINITI dealer.
- Improper maintenance, including incorrect removal and installation of the SRS, can lead to personal injury caused by unintentional activation of the system. For removal of Spiral Cable and Air Bag Module, see the SR section.
- Do not use electrical test equipment on any circuit related to the SRS unless instructed to in this Service Manual. SRS wiring harnesses can be identified by yellow and/or orange harnesses or harness connectors.

PRECAUTIONS WHEN USING POWER TOOLS (AIR OR ELECTRIC) AND HAMMERS

WARNING:

- When working near the Airbag Diagnosis Sensor Unit or other Airbag System sensors with the Ignition ON or engine running, DO NOT use air or electric power tools or strike near the sensor(s) with a hammer. Heavy vibration could activate the sensor(s) and deploy the air bag(s), possibly causing serious injury.
- When using air or electric power tools or hammers, always switch the Ignition OFF, disconnect the battery, and wait at least 3 minutes before performing any service.

Precaution Necessary for Steering Wheel Rotation after Battery Disconnect

INFOID:000000007421749

NOTE:

- Before removing and installing any control units, first turn the push-button ignition switch to the LOCK position, then disconnect both battery cables.
- After finishing work, confirm that all control unit connectors are connected properly, then re-connect both battery cables.
- Always use CONSULT to perform self-diagnosis as a part of each function inspection after finishing work. If a DTC is detected, perform trouble diagnosis according to self-diagnosis results.

This vehicle is equipped with a push-button ignition switch and a steering lock unit.

If the battery is disconnected or discharged, the steering wheel will lock and cannot be turned.

If turning the steering wheel is required with the battery disconnected or discharged, follow the procedure below before starting the repair operation.

OPERATION PROCEDURE

1. Connect both battery cables.

NOTE:

Supply power using jumper cables if battery is discharged.

2. Carry the Intelligent Key or insert it to the key slot and turn the push-button ignition switch to ACC position. (At this time, the steering lock will be released.)
3. Disconnect both battery cables. The steering lock will remain released with both battery cables disconnected and the steering wheel can be turned.
4. Perform the necessary repair operation.

PRECAUTIONS

[COUPE]

< PRECAUTION >

5. When the repair work is completed, re-connect both battery cables. With the brake pedal released, turn the push-button ignition switch from ACC position to ON position, then to LOCK position. (The steering wheel will lock when the push-button ignition switch is turned to LOCK position.)
6. Perform self-diagnosis check of all control units using CONSULT.

Precaution for Work

INFOID:000000007421750

- When removing or disassembling each component, be careful not to damage or deform it. If a component may be subject to interference, be sure to protect it with a shop cloth.
- When removing (disengaging) components with a screwdriver or similar tool, be sure to wrap the component with a shop cloth or vinyl tape to protect it.
- Protect the removed parts with a shop cloth and prevent them from being dropped.
- Replace a deformed or damaged clip.
- If a part is specified as a non-reusable part, always replace it with new one.
- Be sure to tighten bolts and nuts securely to the specified torque.
- After installation is complete, be sure to check that each part works properly.
- Follow the steps below to clean components.
 - Water soluble dirt: Dip a soft cloth into lukewarm water, and wring the water out of the cloth to wipe the dirty area.
Then rub with a soft and dry cloth.
 - Oily dirt: Dip a soft cloth into lukewarm water with mild detergent (concentration: within 2 to 3%), and wipe the dirty area.
Then dip a cloth into fresh water, and wring the water out of the cloth to wipe the detergent off. Then rub with a soft and dry cloth.
- Do not use organic solvent such as thinner, benzene, alcohol, or gasoline.
- For genuine leather seats, use a genuine leather seat cleaner.

A
B
C
D
E
F
G
H
I
K
L
M
N
O
P

INT

PREPARATION

[COUPE]

< PREPARATION >

PREPARATION

PREPARATION

Special Service Tools

INFOID:000000007421751

The actual shapes of Kent-Moore tools may differ from those of special service tools illustrated here.

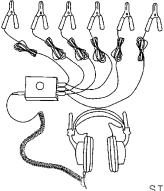
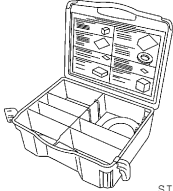
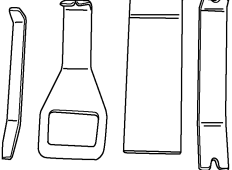
Tool number (Kent-Moore No.) Tool name	Description
— (J-39570) Chassis ear <div style="text-align: center;">  <p>SIIA0993E</p> </div>	Locating the noise
— (J-43980) NISSAN Squeak and Rattle Kit <div style="text-align: center;">  <p>SIIA0994E</p> </div>	Repairing the cause of noise
— (J-46534) Trim Tool Set <div style="text-align: center;">  <p>AWJIA04832Z</p> </div>	Removing trim components

Commercial Service Tools

INFOID:000000007421752

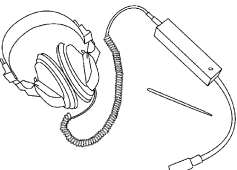
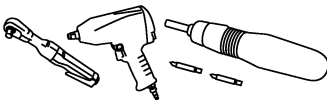
Tool name	Description
Engine ear <div style="text-align: center;">  <p>SIIA0995E</p> </div>	Locating the noise
Power tools <div style="text-align: center;">  <p>PIIB1407E</p> </div>	Loosening nuts, screws and bolts

SYMPTOM DIAGNOSIS

SQUEAK AND RATTLE TROUBLE DIAGNOSES

Work Flow

INFOID:000000007421753

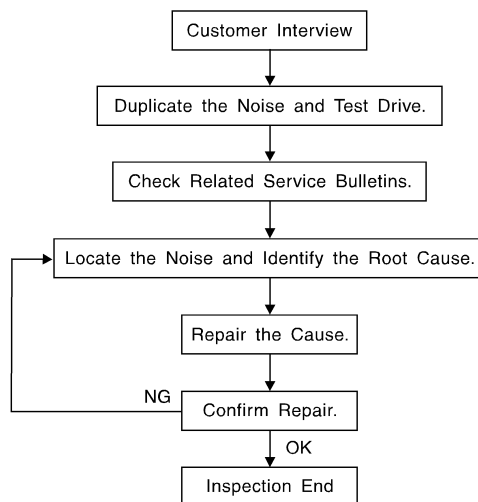

SBT842

CUSTOMER INTERVIEW

Interview the customer if possible, to determine the conditions that exist when the noise occurs. Use the Diagnostic Worksheet during the interview to document the facts and conditions when the noise occurs and any customer's comments; refer to [INT-39, "Diagnostic Worksheet"](#). This information is necessary to duplicate the conditions that exist when the noise occurs.

- The customer may not be able to provide a detailed description or the location of the noise. Attempt to obtain all the facts and conditions that exist when the noise occurs (or does not occur).
- If there is more than one noise in the vehicle, be sure to diagnose and repair the noise that the customer is concerned about. This can be accomplished by test driving the vehicle with the customer.
- After identifying the type of noise, isolate the noise in terms of its characteristics. The noise characteristics are provided so the customer, service adviser and technician are all speaking the same language when defining the noise.
- Squeak —(Like tennis shoes on a clean floor)
Squeak characteristics include the light contact/fast movement/brought on by road conditions/hard surfaces = higher pitch noise/softer surfaces = lower pitch noises/edge to surface = chirping.
- Creak—(Like walking on an old wooden floor)
Creak characteristics include firm contact/slow movement/twisting with a rotational movement/pitch dependent on materials/often brought on by activity.
- Rattle—(Like shaking a baby rattle)
Rattle characteristics include the fast repeated contact/vibration or similar movement/loose parts/missing clip or fastener/incorrect clearance.
- Knock —(Like a knock on a door)
Knock characteristics include hollow sounding/sometimes repeating/often brought on by driver action.
- Tick—(Like a clock second hand)
Tick characteristics include gentle contacting of light materials/loose components/can be caused by driver action or road conditions.
- Thump—(Heavy, muffled knock noise)
Thump characteristics include softer knock/dead sound often brought on by activity.
- Buzz—(Like a bumble bee)
Buzz characteristics include high frequency rattle/firm contact.
- Often the degree of acceptable noise level will vary depending upon the person. A noise that you may judge as acceptable may be very irritating to the customer.
- Weather conditions, especially humidity and temperature, may have a great effect on noise level.

DUPLICATE THE NOISE AND TEST DRIVE

SQUEAK AND RATTLE TROUBLE DIAGNOSES

[COUPE]

< SYMPTOM DIAGNOSIS >

If possible, drive the vehicle with the customer until the noise is duplicated. Note any additional information on the Diagnostic Worksheet regarding the conditions or location of the noise. This information can be used to duplicate the same conditions when you confirm the repair.

If the noise can be duplicated easily during the test drive, to help identify the source of the noise, try to duplicate the noise with the vehicle stopped by doing one or all of the following:

- 1) Close a door.
 - 2) Tap or push/pull around the area where the noise appears to be coming from.
 - 3) Rev the engine.
 - 4) Use a floor jack to recreate vehicle "twist".
 - 5) At idle, apply engine load (electrical load, half-clutch on M/T model, drive position on CVT and A/T models).
 - 6) Raise the vehicle on a hoist and hit a tire with a rubber hammer.
- Drive the vehicle and attempt to duplicate the conditions the customer states exist when the noise occurs.
 - If it is difficult to duplicate the noise, drive the vehicle slowly on an undulating or rough road to stress the vehicle body.

CHECK RELATED SERVICE BULLETINS

After verifying the customer concern or symptom, check ASIST for Technical Service Bulletins (TSBs) related to that concern or symptom.

If a TSB relates to the symptom, follow the procedure to repair the noise.

LOCATE THE NOISE AND IDENTIFY THE ROOT CAUSE

1. Narrow down the noise to a general area. To help pinpoint the source of the noise, use a listening tool (Chassis Ear: J-39570, Engine Ear: J-39565 and mechanic's stethoscope).
2. Narrow down the noise to a more specific area and identify the cause of the noise by:
 - removing the components in the area that you suspect the noise is coming from.
Do not use too much force when removing clips and fasteners, otherwise clips and fasteners can be broken or lost during the repair, resulting in the creation of new noise.
 - tapping or pushing/pulling the component that you suspect is causing the noise.
Do not tap or push/pull the component with excessive force, otherwise the noise will be eliminated only temporarily.
 - feeling for a vibration with your hand by touching the component(s) that you suspect is (are) causing the noise.
 - placing a piece of paper between components that you suspect are causing the noise.
 - looking for loose components and contact marks.
Refer to [INT-37, "Generic Squeak and Rattle Troubleshooting"](#).

REPAIR THE CAUSE

- If the cause is a loose component, tighten the component securely.
- If the cause is insufficient clearance between components:
 - separate components by repositioning or loosening and retightening the component, if possible.
 - insulate components with a suitable insulator such as urethane pads, foam blocks, felt cloth tape or urethane tape. A NISSAN Squeak and Rattle Kit (J-43980) is available through your authorized NISSAN Parts Department.

CAUTION:

Do not use excessive force as many components are constructed of plastic and may be damaged.

Always check with the Parts Department for the latest parts information.

The following materials are contained in the NISSAN Squeak and Rattle Kit (J-43980). Each item can be ordered separately as needed.

URETHANE PADS [1.5 mm (0.059 in) thick]

Insulates connectors, harness, etc.

76268-9E005: 100×135 mm (3.94×5.31 in)/76884-71L01: 60×85 mm (2.36×3.35 in)/76884-71L02: 15×25 mm (0.59×0.98 in)

INSULATOR (Foam blocks)

Insulates components from contact. Can be used to fill space behind a panel.

73982-9E000: 45 mm (1.77 in) thick, 50×50 mm (1.97×1.97 in)/73982-50Y00: 10 mm (0.39 in) thick, 50×50 mm (1.97×1.97 in)

INSULATOR (Light foam block)

80845-71L00: 30 mm (1.18 in) thick, 30×50 mm (1.18×1.97 in)

FELT CLOTH TAPE

Used to insulate where movement does not occur. Ideal for instrument panel applications.

68370-4B000: 15×25 mm (0.59×0.98 in) pad/68239-13E00: 5 mm (0.20 in) wide tape roll. The following materials not found in the kit can also be used to repair squeaks and rattles.

SQUEAK AND RATTLE TROUBLE DIAGNOSES

[COUPE]

< SYMPTOM DIAGNOSIS >

UHMW (TEFLON) TAPE

Insulates where slight movement is present. Ideal for instrument panel applications.

SILICONE GREASE

Used instead of UHMW tape that will be visible or not fit.

Note: Will only last a few months.

SILICONE SPRAY

Use when grease cannot be applied.

DUCT TAPE

Use to eliminate movement.

CONFIRM THE REPAIR

Confirm that the cause of a noise is repaired by test driving the vehicle. Operate the vehicle under the same conditions as when the noise originally occurred. Refer to the notes on the Diagnostic Worksheet.

Generic Squeak and Rattle Troubleshooting

INFOID:000000007421754

Refer to Table of Contents for specific component removal and installation information.

INSTRUMENT PANEL

Most incidents are caused by contact and movement between:

1. The cluster lid A and instrument panel
2. Acrylic lens and combination meter housing
3. Instrument panel to front pillar garnish
4. Instrument panel to windshield
5. Instrument panel pins
6. Wiring harnesses behind the combination meter
7. A/C defroster duct and duct joint

These incidents can usually be located by tapping or moving the components to duplicate the noise or by pressing on the components while driving to stop the noise. Most of these incidents can be repaired by applying felt cloth tape or silicone spray (in hard to reach areas). Urethane pads can be used to insulate wiring harness.

CAUTION:

Do not use silicone spray to isolate a squeak or rattle. If you saturate the area with silicone, you will not be able to recheck the repair.

CENTER CONSOLE

Components to pay attention to include:

1. Shift selector assembly cover to finisher
2. A/C control unit and cluster lid C
3. Wiring harnesses behind audio and A/C control unit

The instrument panel repair and isolation procedures also apply to the center console.

DOORS

Pay attention to the:

1. Finisher and inner panel making a slapping noise
2. Inside handle escutcheon to door finisher
3. Wiring harnesses tapping
4. Door striker out of alignment causing a popping noise on starts and stops

Tapping or moving the components or pressing on them while driving to duplicate the conditions can isolate many of these incidents. You can usually insulate the areas with felt cloth tape or insulator foam blocks from the NISSAN Squeak and Rattle Kit (J-43980) to repair the noise.

TRUNK

Trunk noises are often caused by a loose jack or loose items put into the trunk by the owner.

In addition look for:

1. Trunk lid bumpers out of adjustment
2. Trunk lid striker out of adjustment
3. The trunk lid torsion bars knocking together

A
B
C
D
E
F
G
H
I
INT
K
L
M
N
O
P

SQUEAK AND RATTLE TROUBLE DIAGNOSES

[COUPE]

< SYMPTOM DIAGNOSIS >

4. A loose license plate or bracket

Most of these incidents can be repaired by adjusting, securing or insulating the item(s) or component(s) causing the noise.

SUNROOF/HEADLINING

Noises in the sunroof/headlining area can often be traced to one of the following:

1. Sunroof lid, rail, linkage or seals making a rattle or light knocking noise
2. Sun visor shaft shaking in the holder
3. Front or rear windshield touching headliner and squeaking

Again, pressing on the components to stop the noise while duplicating the conditions can isolate most of these incidents. Repairs usually consist of insulating with felt cloth tape.

OVERHEAD CONSOLE (FRONT AND REAR)

Overhead console noises are often caused by the console panel clips not being engaged correctly. Most of these incidents are repaired by pushing up on the console at the clip locations until the clips engage.

In addition look for:

1. Loose harness or harness connectors.
2. Front console map/reading lamp lens loose.
3. Loose screws at console attachment points.

SEATS

When isolating seat noise it's important to note the position the seat is in and the load placed on the seat when the noise is present. These conditions should be duplicated when verifying and isolating the cause of the noise.

Cause of seat noise include:

1. Headrest rods and holder
2. A squeak between the seat pad cushion and frame
3. The rear seatback lock and bracket

These noises can be isolated by moving or pressing on the suspected components while duplicating the conditions under which the noise occurs. Most of these incidents can be repaired by repositioning the component or applying urethane tape to the contact area.

UNDERHOOD

Some interior noise may be caused by components under the hood or on the engine wall. The noise is then transmitted into the passenger compartment.

Causes of transmitted underhood noise include:

1. Any component installed to the engine wall
2. Components that pass through the engine wall
3. Engine wall mounts and connectors
4. Loose radiator installation pins
5. Hood bumpers out of adjustment
6. Hood striker out of adjustment

These noises can be difficult to isolate since they cannot be reached from the interior of the vehicle. The best method is to secure, move or insulate one component at a time and test drive the vehicle. Also, engine RPM or load can be changed to isolate the noise. Repairs can usually be made by moving, adjusting, securing, or insulating the component causing the noise.

SQUEAK AND RATTLE TROUBLE DIAGNOSES

< SYMPTOM DIAGNOSIS >

[COUPE]

Diagnostic Worksheet

INFOID:000000007421755

Dear Customer:

We are concerned about your satisfaction with your vehicle. Repairing a squeak or rattle sometimes can be very difficult. To help us fix your vehicle right the first time, please take a moment to note the area of the vehicle where the squeak or rattle occurs and under what conditions. You may be asked to take a test drive with a service advisor or technician to ensure we confirm the noise you are hearing.

SQUEAK & RATTLE DIAGNOSTIC WORKSHEET

I. WHERE DOES THE NOISE COME FROM? (circle the area of the vehicle)

The illustrations are for reference only, and may not reflect the actual configuration of your vehicle.

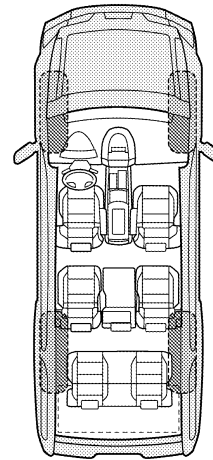
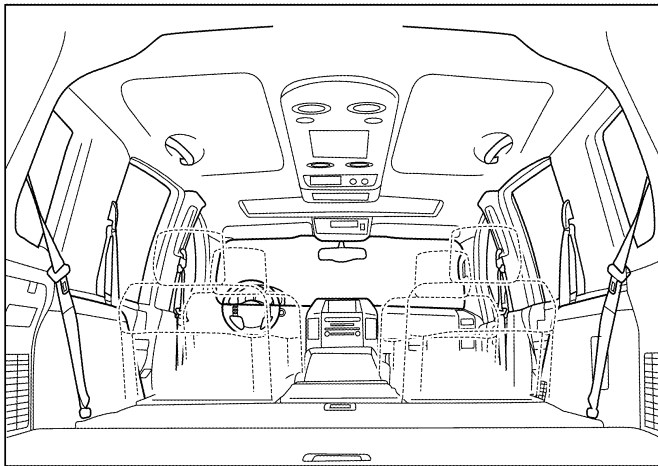
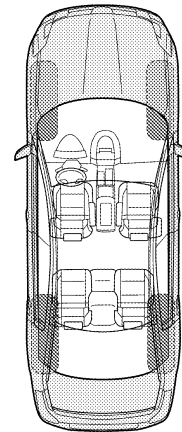
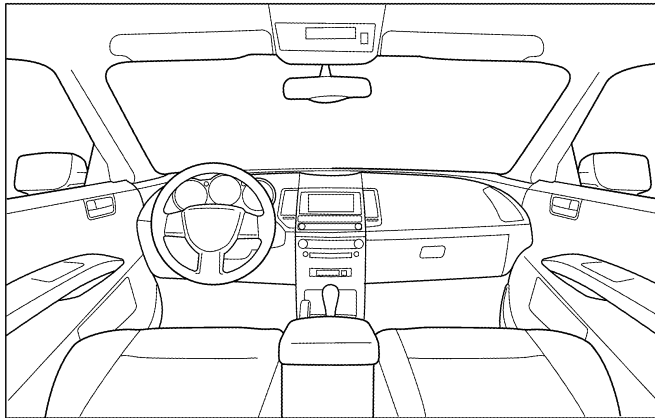

Continue to page 2 of the worksheet and briefly describe the location of the noise or rattle. In addition, please indicate the conditions which are present when the noise occurs.

A
B
C
D
E
F
G
H
I
INT
K
L
M
N
O
P

SQUEAK AND RATTLE TROUBLE DIAGNOSES

< SYMPTOM DIAGNOSIS >

[COUPE]

SQUEAK & RATTLE DIAGNOSTIC WORKSHEET - page 2

Briefly describe the location where the noise occurs:

II. WHEN DOES IT OCCUR? (please check the boxes that apply)

- | | |
|---|--|
| <input type="checkbox"/> Anytime | <input type="checkbox"/> After sitting out in the rain |
| <input type="checkbox"/> 1st time in the morning | <input type="checkbox"/> When it is raining or wet |
| <input type="checkbox"/> Only when it is cold outside | <input type="checkbox"/> Dry or dusty conditions |
| <input type="checkbox"/> Only when it is hot outside | <input type="checkbox"/> Other: |

III. WHEN DRIVING:

- Through driveways
- Over rough roads
- Over speed bumps
- Only about ____ mph
- On acceleration
- Coming to a stop
- On turns: left, right or either (circle)
- With passengers or cargo
- Other: _____
- After driving ____ miles or ____ minutes

IV. WHAT TYPE OF NOISE

- Squeak (like tennis shoes on a clean floor)
- Creak (like walking on an old wooden floor)
- Rattle (like shaking a baby rattle)
- Knock (like a knock at the door)
- Tick (like a clock second hand)
- Thump (heavy muffled knock noise)
- Buzz (like a bumble bee)

TO BE COMPLETED BY DEALERSHIP PERSONNEL

Test Drive Notes:

	YES	NO	Initials of person performing
Vehicle test driven with customer	<input type="checkbox"/>	<input type="checkbox"/>	_____
- Noise verified on test drive	<input type="checkbox"/>	<input type="checkbox"/>	_____
- Noise source located and repaired	<input type="checkbox"/>	<input type="checkbox"/>	_____
- Follow up test drive performed to confirm repair	<input type="checkbox"/>	<input type="checkbox"/>	_____

VIN: _____ Customer Name _____
W.O.# _____ Date: _____

This form must be attached to Work Order

LATA0071E

DOOR FINISHER

< REMOVAL AND INSTALLATION >

[COUPE]

REMOVAL AND INSTALLATION

DOOR FINISHER

Exploded View

INFOID:000000007421756

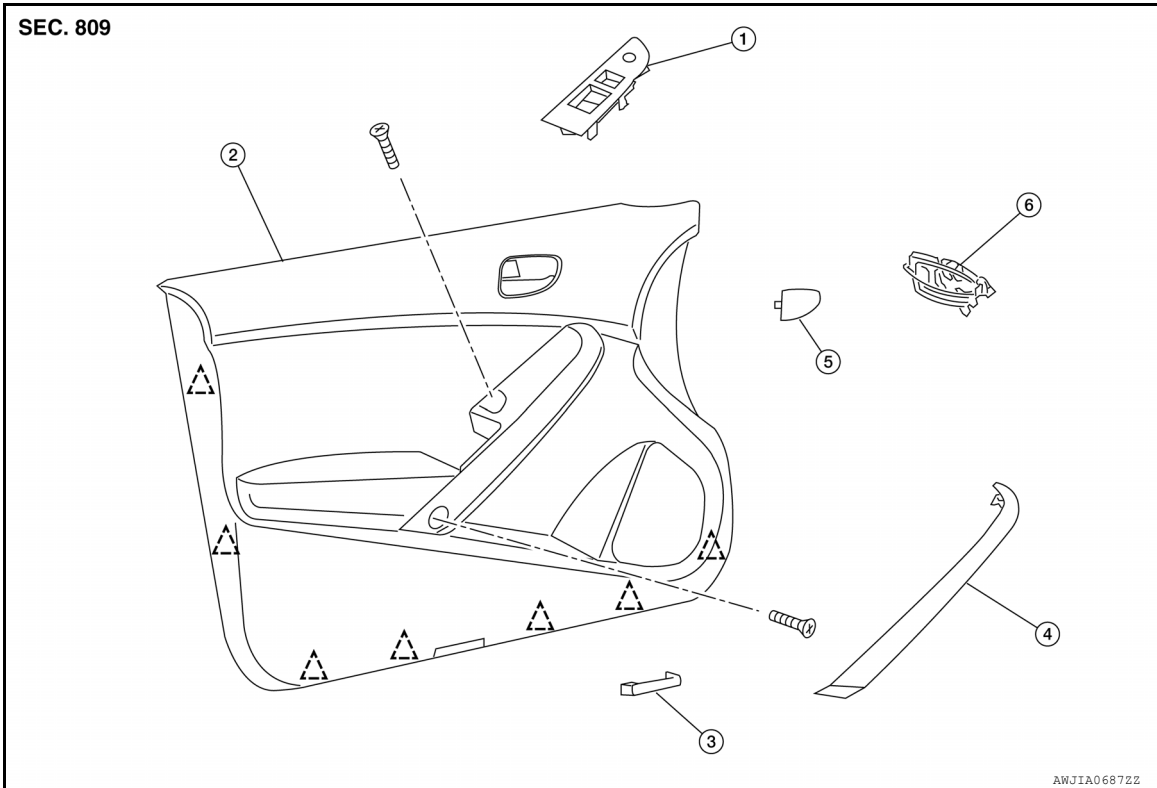

- | | | |
|--|-------------------------------------|--------------------------|
| 1. Main or front power window and door lock/unlock switch finisher | 2. Front door finisher | 3. Step lamp |
| 4. Armrest finisher | 5. Inside release handle escutcheon | 6. Inside release handle |

 Clip

Removal and Installation

INFOID:000000007421757

FRONT DOOR FINISHER

Removal

1. Release the pawls at the rear edge and remove inside release handle escutcheon, then remove the screw.
2. Remove the main power window and door lock/unlock switch finisher (LH) or front power window and door lock/unlock switch finisher (RH). Refer to [PWC-192, "Removal and Installation"](#) (LH) or [PWC-193, "Removal and Installation"](#) (RH).
3. Remove the front door finisher screw beneath main or front power window and door lock/unlock switch finisher.

DOOR FINISHER

[COUPE]

< REMOVAL AND INSTALLATION >

4. Place a suitable tool (A) under the rear corner of the armrest finisher (1) and disengage the bottom plastic clips. Slide the suitable tool up to disengage the three metal clips.

CAUTION:

- Do not pull on the armrest finisher.
- Armrest is not serviceable. Any attempt to remove the armrest will render part damaged and unusable.

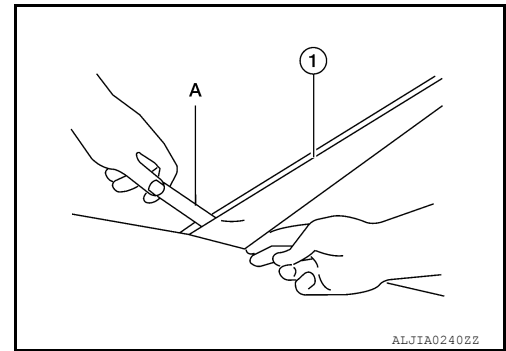

5. Continue to move the suitable tool (A) and disengage the upper metal clip and remove armrest finisher (1).

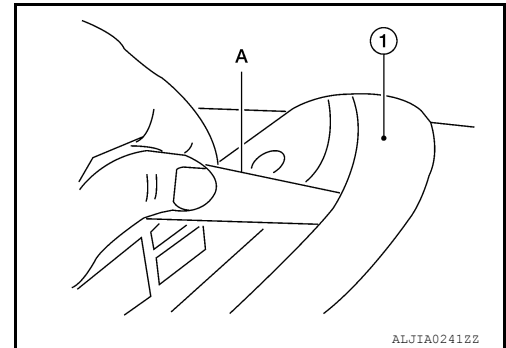

6. Remove the front door finisher screw beneath armrest finisher.
7. Release the clips around outer edge, then remove front door finisher.
8. Disconnect the step lamp connector.
9. Disconnect inside release handle and lock knob cables from back of front door finisher.
10. Remove the inside release handle.

Installation

Installation is in the reverse order of removal.

BODY SIDE TRIM

< REMOVAL AND INSTALLATION >

[COUPE]

BODY SIDE TRIM

Exploded View

INFOID:000000007421758

SEC. 769

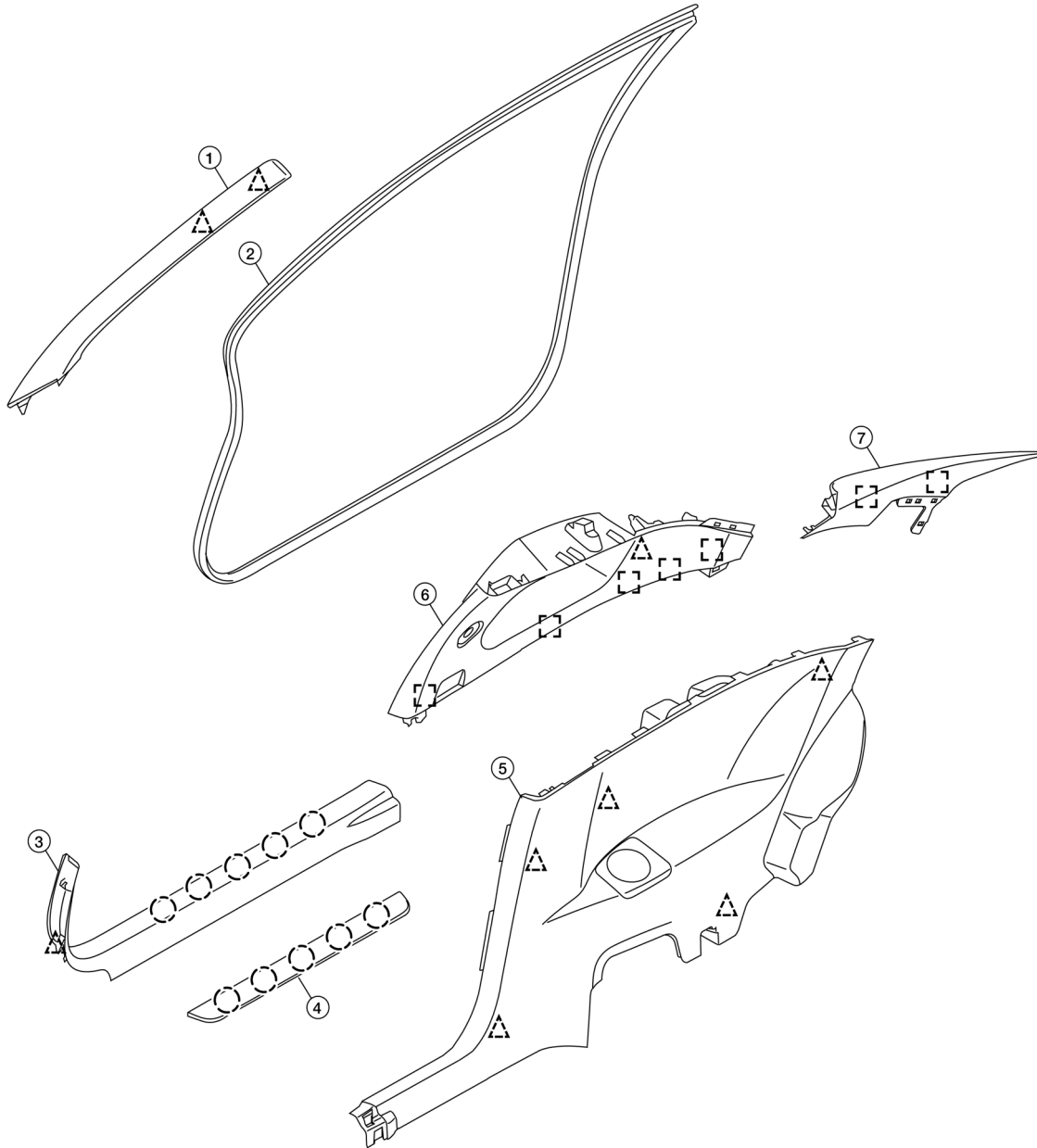

A
B
C
D
E
F
G
H
I
INT
K
L
M
N
O
P

- 1. Front pillar finisher
- 4. Front sill plate cover

- 2. Front body side welt
- 5. Rear lower finisher

- 3. Front kicking plate
- 6. Upper pillar finisher

AWJIA05972Z

BODY SIDE TRIM

< REMOVAL AND INSTALLATION >

[COUPE]

7. Rear pillar finisher



Clip C101



Metal clip



Pawl

Removal and Installation

INFOID:000000007421759

CAUTION:

- Wrap the tip of a suitable tool with a cloth when removing metal clips from garnishes.
- When removing, always use suitable tools made of plastic.
- When removing or installing body side welts, do not allow butyl seal to come in contact with pillar finishers.
- Make sure that clips are fully aligned with panel holes on body when installing, then press them in completely.
- Insert a suitable clip removing tool wrapped with a shop cloth inserted into the part shown by the arrow (between the clip and the body side panel), then release the clip.

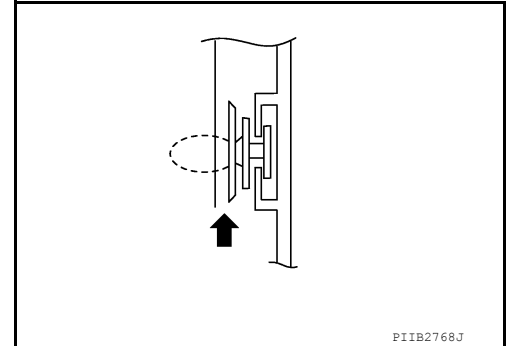

PIIB2768J

FRONT PILLAR FINISHER

Removal

1. Partially remove front body side welt.
2. Release the clips, then remove front pillar finisher.

Installation

Installation is in the reverse order of removal.

FRONT KICKING PLATE

Removal

Release the clip and pawls, then remove front kicking plate.

Installation

Installation is in the reverse order of removal.

FRONT BODY SIDE WELT

Removal

1. Release the clip and pawls, then remove front kicking plate.
2. Release front body side welt from the body opening, then remove front body side welt.

Installation

Installation is in the reverse order of removal.

REAR PILLAR FINISHER

Removal

1. Release the metal clips, then remove rear pillar finisher.
2. Remove rear pillar finisher tether bolt.

Installation

Installation is in the reverse order of removal.

REAR LOWER FINISHER

Removal

1. Remove the rear seat back and seat cushion. Refer to [SE-23. "Removal and Installation"](#).

BODY SIDE TRIM

[COUPE]

< REMOVAL AND INSTALLATION >

2. Partially remove front body side welt.
3. Release the clips, then remove rear lower finisher.

A

Installation

Installation is in the reverse order of removal.

B

UPPER PILLAR FINISHER

Removal

1. Partially remove front body side welt.
2. Release the metal clips, then remove rear pillar finisher.
3. Remove the rear pillar finisher tether bolt.
4. Remove seat belt anchor. Refer to [SB-12. "Removal and Installation"](#)
5. Release the clips, then remove upper pillar finisher.

C

D

Installation

Installation is in the reverse order of removal.

E

FRONT SILL PLATE COVER

Removal

Release the pawls, then remove the front sill plate cover.

F

Installation

Installation is in the reverse order of removal.

G

H

I

INT

K

L

M

N

O

P

REAR PARCEL SHELF FINISHER

< REMOVAL AND INSTALLATION >

[COUPE]

REAR PARCEL SHELF FINISHER

Exploded View

INFOID:000000007421760

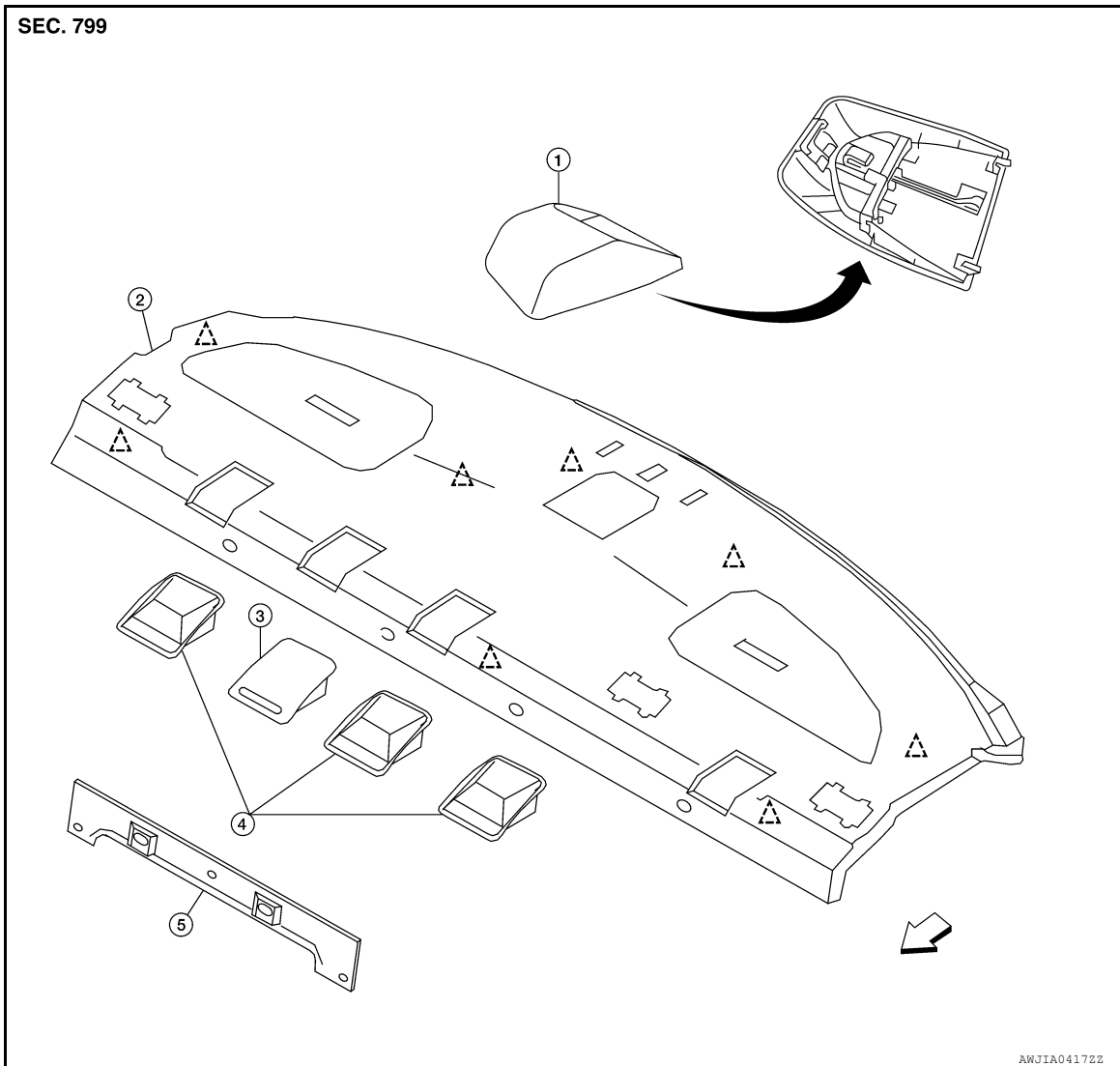

- | | | |
|---------------------------|-------------------------------|-----------------------|
| 1. High mounted stop lamp | 2. Rear parcel shelf finisher | 3. Key cylinder cover |
| 4. Child anchor cover | 5. Seatback latch cover | △ Clip C101 |

← Vehicle front

Removal and Installation

INFOID:000000007421761

REMOVAL

1. Remove rear lower finisher RH/LH. Refer to [INT-44, "Removal and Installation"](#).
2. Remove rear pillar finisher RH/LH. Refer to [INT-44, "Removal and Installation"](#).
3. Remove upper pillar finisher RH/LH. Refer to [INT-44, "Removal and Installation"](#).
4. Remove the clips, then remove rear seatback latch cover.
5. Remove the key cylinder cover and child anchor covers from the rear parcel shelf finisher. Refer to [INT-47, "Removal and Installation - Child Anchor and Key Cylinder Covers"](#).
6. Remove high mounted stop lamp. Refer to [EXL-214, "Removal and Installation"](#).
7. Remove the clips, then remove rear parcel shelf finisher.

REAR PARCEL SHELF FINISHER

[COUPE]

< REMOVAL AND INSTALLATION >

INSTALLATION

Installation is in the reverse order of removal.

CAUTION:

Make sure that clips are fully aligned with panel holes on body when installing, then press them in completely.

Removal and Installation - Child Anchor and Key Cylinder Covers

INFOID:000000007619227

REMOVAL

1. Lift the child anchor cover or key cylinder cover to a full open position.

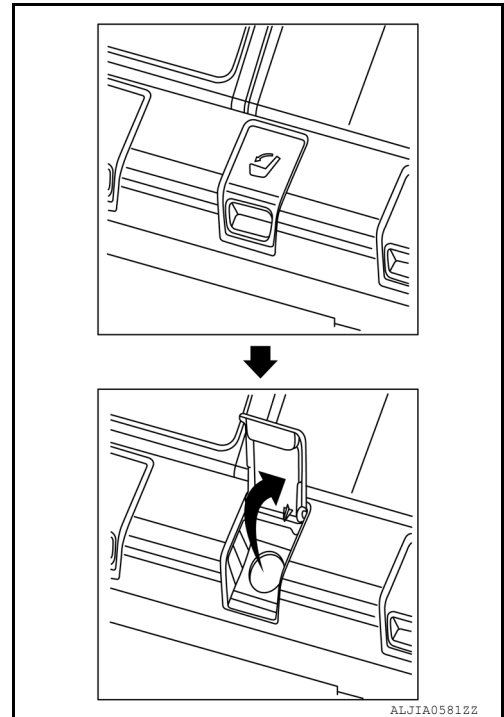

2. Rotate the child anchor cover or key cylinder cover as shown to disengage the left hinge (A) of the cover from the left retaining pin, then slide cover slightly back to the left to remove the right hinge (B) from the right retaining pin.

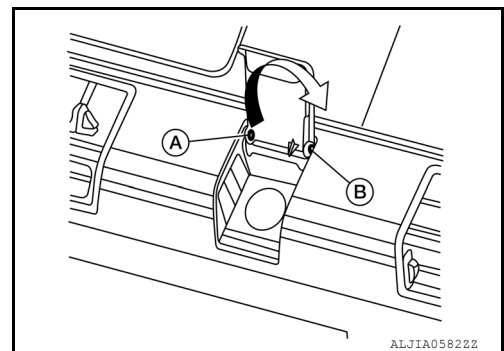

INSTALLATION

1. Install the child anchor cover or key cylinder cover by gently sliding the right hinge (A) of the child anchor cover or key cylinder cover onto the right retaining pin (B).

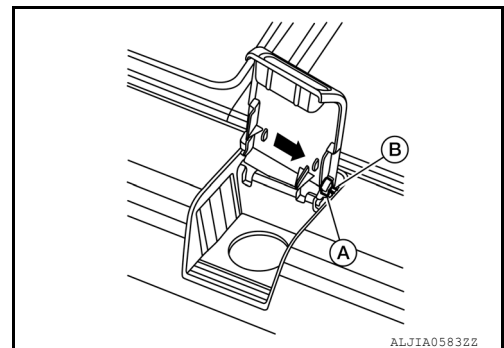

A
B
C
D
E
F
G
H
I

INT

K
L
M
N
O
P

REAR PARCEL SHELF FINISHER

[COUPE]

< REMOVAL AND INSTALLATION >

2. Gently push down on the child anchor cover or key cylinder cover left hinge (A) to engage it to the left retaining pin (B). A snapping sound will be heard once the hinge and the retaining pin are locked together.

CAUTION:

Make sure the left hinge is completely aligned with the left retaining pin. If the two items are not aligned, and the cover is forced it may result in the breaking of the retaining pin and the rear parcel shelf finisher needing to be replaced.

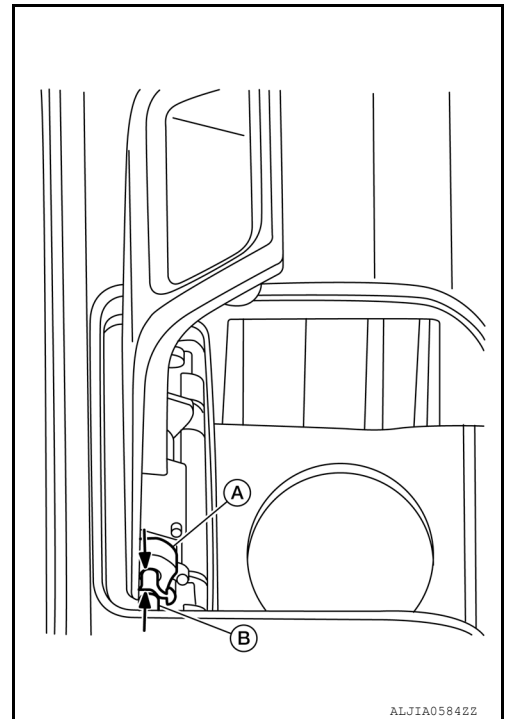

3. Lower the child anchor cover or key cylinder cover to the fully closed position.

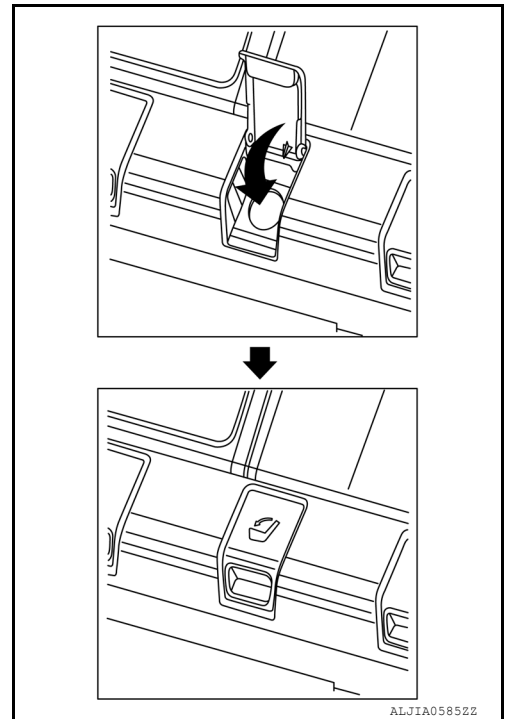

FLOOR TRIM

< REMOVAL AND INSTALLATION >

[COUPE]

FLOOR TRIM

Exploded View

INFOID:000000007421762

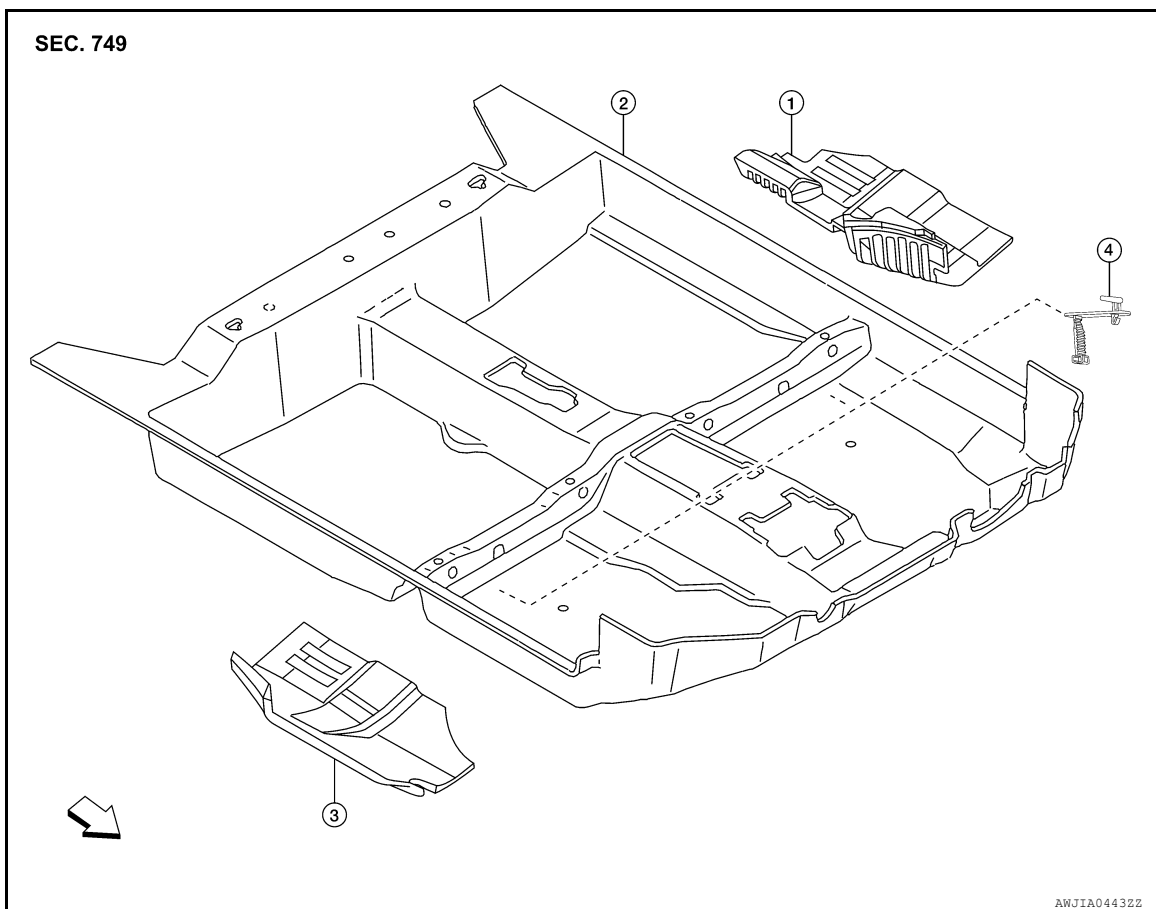

- 1. Spacer (LH)
 - 2. Floor carpet
 - 3. Spacer (RH)
 - 4. Floor mat hooks
- ↖ Vehicle front

Removal and Installation

INFOID:000000007421763

REMOVAL

1. Remove front seats (RH/LH) and rear seat cushion. Refer to [SE-18, "Removal and Installation- Seat Assembly"](#) (front seat) and [SE-23, "Removal and Installation"](#) (rear seat).
2. Remove front body side welt. Refer to [INT-44, "Removal and Installation"](#).
3. Remove center console. Refer to [IP-20, "Removal and Installation"](#).
4. Remove the diagnosis sensor unit. Refer to [SR-20, "Removal and Installation"](#).
5. Remove front seat belt floor anchor bolt (RH/LH). Refer to [SB-7, "Exploded View"](#).
6. Remove rear lower finisher. Refer to [INT-44, "Removal and Installation"](#).
7. Remove floor mat hooks.
8. Remove the front kicking plates. Refer to [INT-44, "Removal and Installation"](#).
9. Fold corners toward center, then remove floor carpet.

INSTALLATION

Installation is in the reverse order of removal.

HEADLINING

< REMOVAL AND INSTALLATION >

[COUPE]

HEADLINING

Exploded View

INFOID:000000007421764

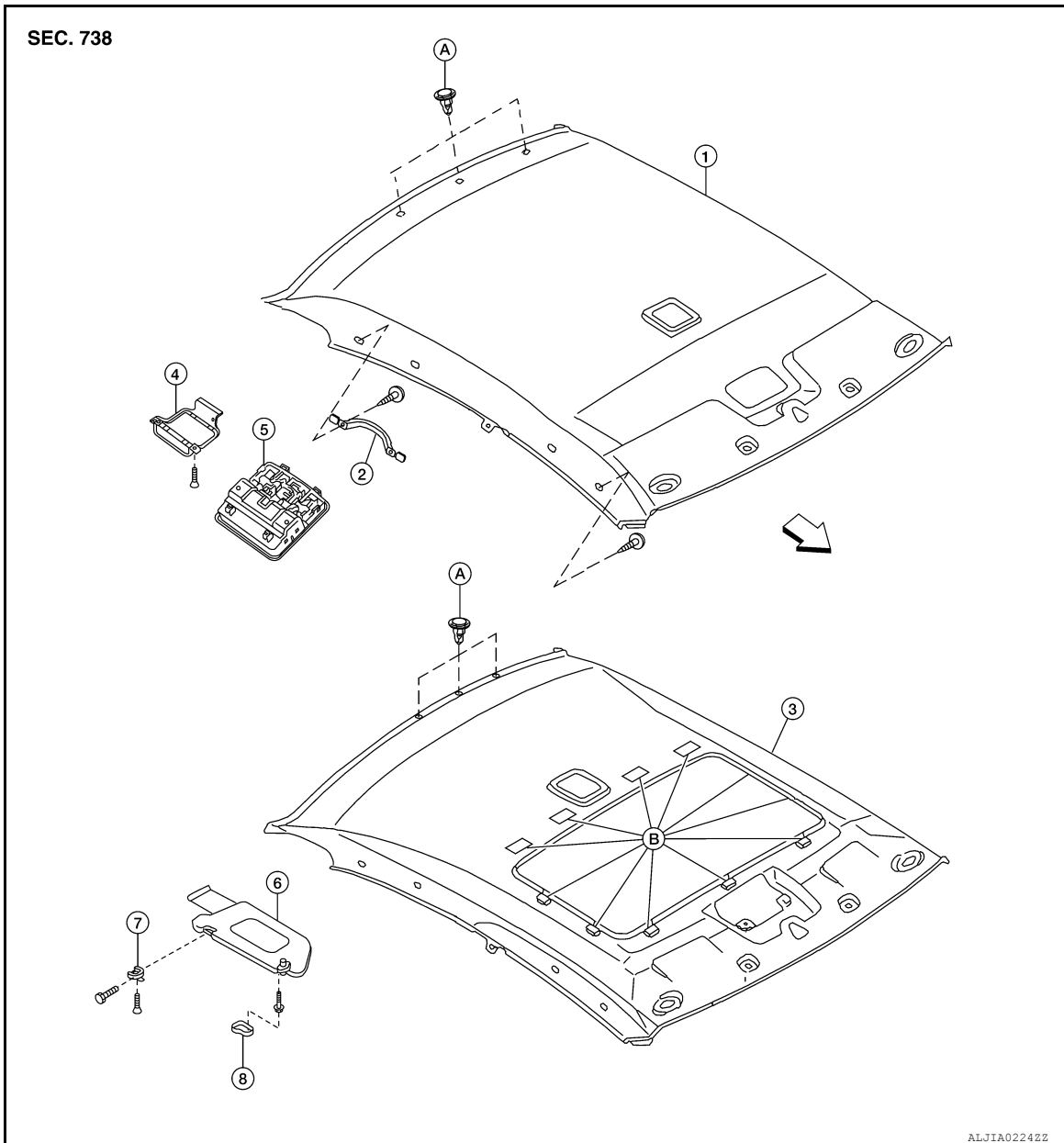

- | | | |
|--|---------------------------------|---------------------------------------|
| 1. Headlining assembly (without sunroof) | 2. Assist grip | 3. Headlining assembly (with sunroof) |
| 4. Front room/map lamp assembly bracket | 5. Front room/map lamp assembly | 6. Sunvisor |
| 7. Sunvisor holder | 8. Sunvisor cover | ← Vehicle front |
| A. Clip C101 | B. Dual lock fastener | |

Removal and Installation

INFOID:000000007421765

CAUTION:

- Disconnect the negative and positive battery terminals and wait at least three minutes.
- Be careful not to bend headlining during removal or installation.

NOTE:

Front interior room lamp is serviced as part of the headliner assembly.

HEADLINING

< REMOVAL AND INSTALLATION >

[COUPE]

REMOVAL

1. Remove rear seat cushion and seatbacks. Refer to [SE-23, "Removal and Installation"](#).
2. Recline the front seats to the fully reclined position.
3. Disconnect the negative and positive battery terminals.
4. Remove front pillar finishers (RH/LH). Refer to [INT-44, "Removal and Installation"](#).
5. Remove front body side welts (RH/LH).
6. Remove upper and rear lower pillar finishers (RH/LH). Refer to [INT-44, "Removal and Installation"](#).
7. Disconnect headlining harness and antenna feeder connectors.
8. Disconnect antenna amplifier and rear window defogger connectors.
9. Release the molded clip, then remove assist grips.

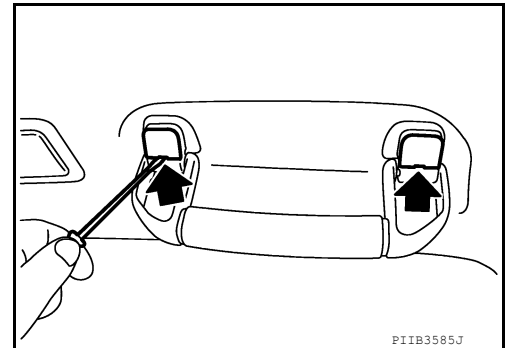

10. Remove the sunvisors (RH/LH).
 - a. Remove the sunvisor covers and screws.
 - b. Disconnect the connector and remove each of the sunvisors.
11. Insert a suitable thin tool (A) at approximately a 30 degree angle into the sunvisor holder notch on the front of the sunvisor holder (1) and press in the locking tab (B) to release it. While holding in lock tab (B), turn the sunvisor holder (1) 90 degrees to release it from the headliner.
 - If the sunvisor holder (1) does not fully rotate, make sure that the suitable thin tool (A) is pressing in on the locking tab (B) and is not positioned under locking tab (B). Reinsert the suitable thin tool (A) as necessary to release the locking tab (B).

• <⇐: Front

CAUTION:

Do not force the sunvisor holder when removing as the locking tab may be damaged if the suitable thin tool is not positioned correctly.

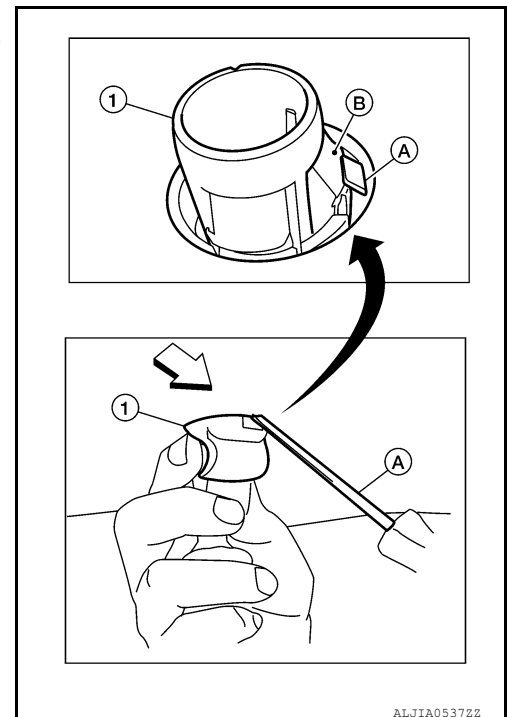

12. Remove the front room/map lamp bracket and front room/map lamp assembly. Refer to [INL-108, "Removal and Installation"](#).
13. For sunroof equipped vehicles, use a suitable tool to release dual lock fastener(s) around the sunroof opening and release the sunroof clip.
14. Disconnect the rear view mirror.
15. Release the three hidden clips near the rear edge of headliner using a suitable tool.
16. Drop headlining down and carefully rotate into position. Remove headlining through door opening.

CAUTION:

HEADLINING

< REMOVAL AND INSTALLATION >

[COUPE]

-
- **When removing, two workers (one for front and one for rear of headlining) are required.**
 - **Cover center console finisher upper surface with a shop cloth to prevent damage.**

INSTALLATION

Installation is in the reverse order of removal.

TRUNK ROOM TRIM & TRUNK LID FINISHER

< REMOVAL AND INSTALLATION >

[COUPE]

TRUNK ROOM TRIM & TRUNK LID FINISHER

Exploded View

INFOID:000000007421766

TRUNK ROOM TRIM

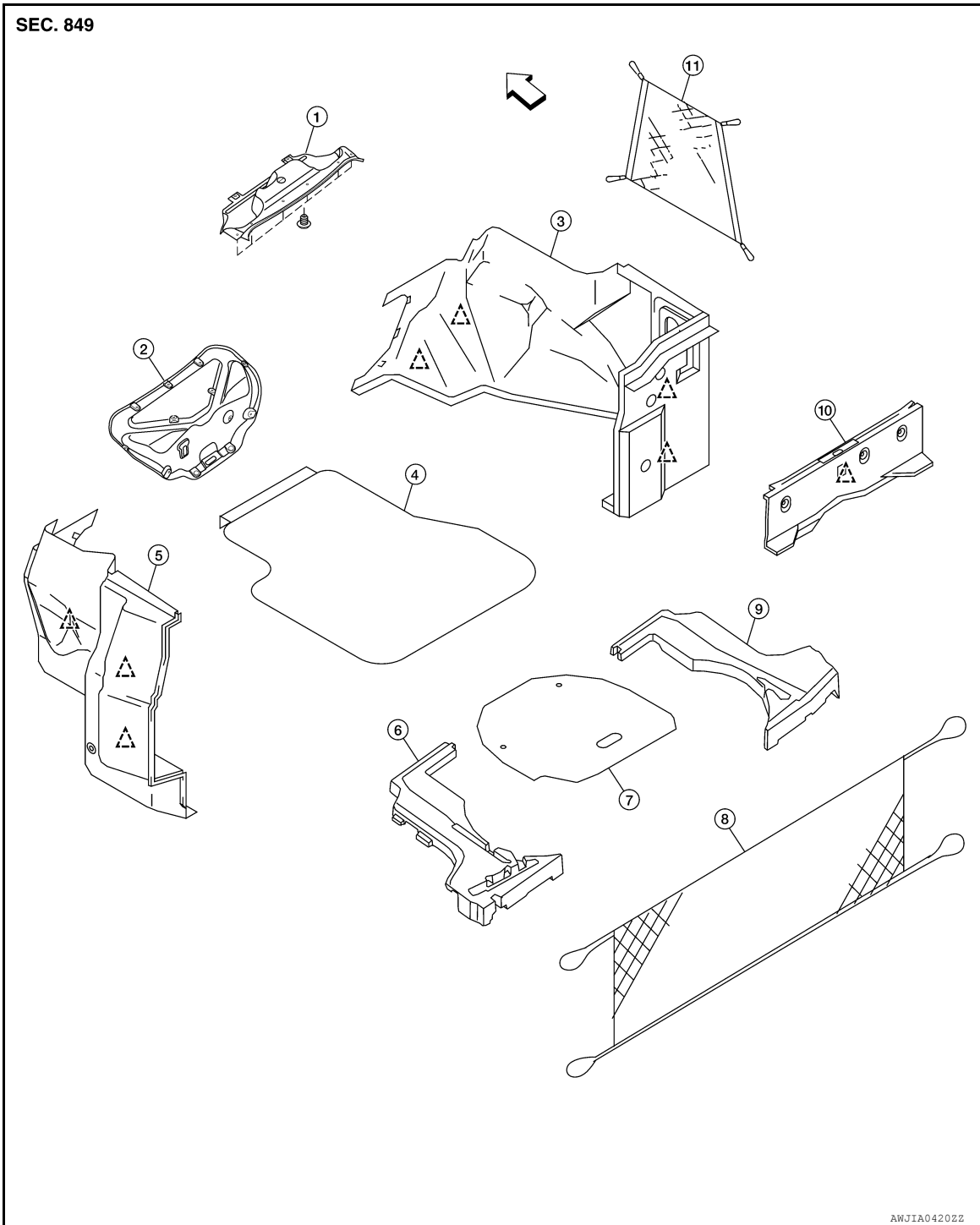

- | | | |
|-------------------------|-----------------------------|-----------------------------|
| 1. Upper trunk finisher | 2. Trunk lid finisher | 3. Trunk side finisher (RH) |
| 4. Trunk floor carpet | 5. Trunk side finisher (LH) | 6. Trunk spacer (LH) |
| 7. Spare tire cover | 8. Trunk net rear | 9. Trunk spacer (RH) |
| 10. Trunk rear finisher | 11. Trunk net side | △ Clip |

← Vehicle front

A
B
C
D
E
F
G
H
I
INT
K
L
M
N
O
P

TRUNK ROOM TRIM & TRUNK LID FINISHER

< REMOVAL AND INSTALLATION >

[COUPE]

Removal and Installation

INFOID:000000007421767

REMOVAL

1. Release the latch, then position rear seatbacks (RH/LH) to fold down position.
2. Remove the rear seatback trim. Refer to [SE-23, "Removal and Installation"](#).
3. Release the clips, then remove trunk floor carpet.
4. Remove trunk net rear and trunk net side (if equipped).
5. Release the clips, then remove trunk rear finisher.
6. Release the clips, then remove upper trunk finisher.
7. Release the clips, then remove trunk side finishers (RH/LH).
8. Remove spare tire cover and trunk spacers (RH/LH).
9. Release the clips and remove trunk lid finisher.

INSTALLATION

Installation is in the reverse order of removal.