

SECTION **PG**

POWER SUPPLY, GROUND & CIRCUIT ELEMENTS

CONTENTS

COUPE		FUSE, FUSIBLE LINK AND RELAY BOX	63	F
BASIC INSPECTION	3	Terminal Arrangement	63	
BATTERY	3	IPDM E/R (INTELLIGENT POWER DISTRIBUTION MODULE ENGINE ROOM)	64	G
How to Handle Battery	3	Fuse, Connector and Terminal Arrangement	64	
Work Flow	3	PRECAUTION	65	H
INSPECTION AND ADJUSTMENT	6	PRECAUTIONS	65	
ADDITIONAL SERVICE WHEN REMOVING BATTERY NEGATIVE TERMINAL	6	Precaution for Supplemental Restraint System (SRS) "AIR BAG" and "SEAT BELT PRE-TENSIONER"	65	I
ADDITIONAL SERVICE WHEN REMOVING BATTERY NEGATIVE TERMINAL : Special Repair Requirement	6	Precaution Necessary for Steering Wheel Rotation After Battery Disconnect	65	J
DTC/CIRCUIT DIAGNOSIS	7	Battery Service	66	
POWER SUPPLY ROUTING CIRCUIT	7	PREPARATION	67	K
Wiring Diagram — Battery Power Supply —	7	PREPARATION	67	
Wiring Diagram — Accessory Power Supply —	14	Special Service Tool	67	L
Wiring Diagram — Ignition Power Supply —	17	Commercial Service Tool	67	
Fuse	25	REMOVAL AND INSTALLATION	68	PG
Fusible Link	25	BATTERY	68	
GROUND	26	Exploded View	68	
Ground Distribution	26	Removal and Installation (Battery)	68	N
HARNESS	34	Removal and Installation (Battery Tray)	69	
Harness Layout	34	SERVICE DATA AND SPECIFICATIONS (SDS)	70	O
ELECTRICAL UNITS LOCATION	53	BATTERY	70	
Electrical Units Location	53	Battery	70	P
HARNESS CONNECTOR	57	SEDAN		
Description	57	BASIC INSPECTION	71	
STANDARDIZED RELAY	60	BATTERY	71	
Description	60	How to Handle Battery	71	
FUSE BLOCK - JUNCTION BOX (J/B)	62	Work Flow	71	
Terminal Arrangement	62			

INSPECTION AND ADJUSTMENT	74	FUSE, FUSIBLE LINK AND RELAY BOX	135
ADDITIONAL SERVICE WHEN REMOVING BATTERY NEGATIVE TERMINAL	74	Terminal Arrangement	135
ADDITIONAL SERVICE WHEN REMOVING BATTERY NEGATIVE TERMINAL : Special Repair Requirement	74	IPDM E/R (INTELLIGENT POWER DISTRIBUTION MODULE ENGINE ROOM)	136
DTC/CIRCUIT DIAGNOSIS	75	Fuse, Connector and Terminal Arrangement	136
POWER SUPPLY ROUTING CIRCUIT	75	PRECAUTION	137
Wiring Diagram — Battery Power Supply —	75	PRECAUTIONS	137
Wiring Diagram — Accessory Power Supply —	82	Precaution for Supplemental Restraint System (SRS) "AIR BAG" and "SEAT BELT PRE-TENSIONER"	137
Wiring Diagram — Ignition Power Supply —	85	Precaution Necessary for Steering Wheel Rotation After Battery Disconnect	137
Fuse	93	Battery Service	138
Fusible Link	93	PREPARATION	139
GROUND	94	PREPARATION	139
Ground Distribution	94	Special Service Tool	139
HARNESS	103	Commercial Service Tool	139
Harness Layout	103	REMOVAL AND INSTALLATION	140
ELECTRICAL UNITS LOCATION	125	BATTERY	140
Electrical Units Location	125	Exploded View	140
HARNESS CONNECTOR	129	Removal and Installation (Battery)	140
Description	129	Removal and Installation (Battery Tray)	141
STANDARDIZED RELAY	132	SERVICE DATA AND SPECIFICATIONS (SDS)	142
Description	132	BATTERY	142
FUSE BLOCK - JUNCTION BOX (J/B)	134	Battery	142
Terminal Arrangement	134		

BASIC INSPECTION

BATTERY

How to Handle Battery

INFOID:000000009326005

CAUTION:

- If it becomes necessary to start the engine with a booster battery and jumper cables, use a 12-volt booster battery.
- After connecting battery cables, ensure that they are tightly clamped to battery terminals for good contact.
- Never add distilled water through the hole used to check specific gravity.

METHODS OF PREVENTING OVER-DISCHARGE

- The following precautions must be taken to prevent over-discharging a battery.
- The battery surface (particularly its top) should always be kept clean and dry.
 - The terminal connections should be clean and tight.
 - At every routine maintenance, check the electrolyte level.
This also applies to batteries designated as "low maintenance" and "maintenance-free".

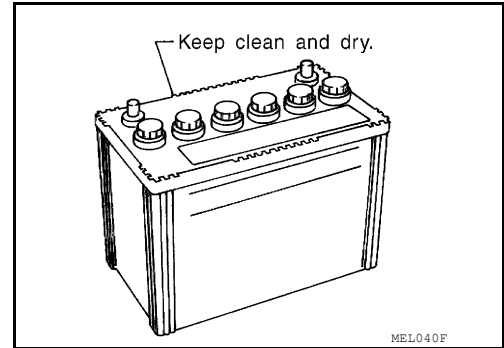

- When the vehicle is not going to be used over a long period of time, disconnect the battery cable from the negative terminal. (If the vehicle has an extended storage switch, turn it off.)

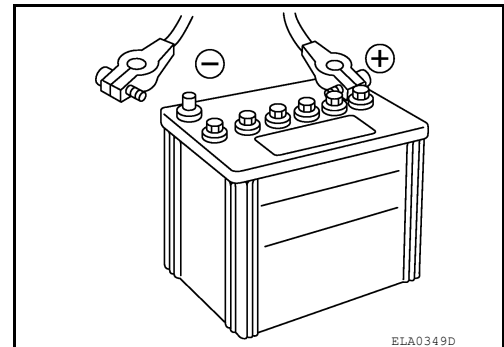

Work Flow

INFOID:000000009325998

BATTERY DIAGNOSIS WITH EXP-800 NI OR GR8-1200 NI

To diagnose and confirm the condition of the battery, use the following special service tools:

- EXP-800 NI Battery and electrical diagnostic analyzer
- GR8-1200 NI Multitasking battery and electrical diagnostic station

NOTE:

Refer to the applicable Instruction Manual for proper battery diagnosis procedures.

BATTERY DIAGNOSIS WITHOUT EXP-800 NI OR GR8-1200 NI

Checking Electrolyte Level

WARNING:

Never allow battery fluid to come in contact with skin, eyes, fabrics, or painted surfaces. After touching a battery, never touch or rub your eyes until you have thoroughly washed your hands. If acid contacts eyes, skin or clothing, immediately flush with water for 15 minutes and seek medical attention. Failure to do this may cause personal injury or damage to clothing or the painted surfaces.

A
B
C
D
E
F
G
H
I
J
K
L

PG

N
O
P

BATTERY

[COUPE]

< BASIC INSPECTION >

- Remove the cell plug using a suitable tool.
- Add distilled water up to the MAX level.

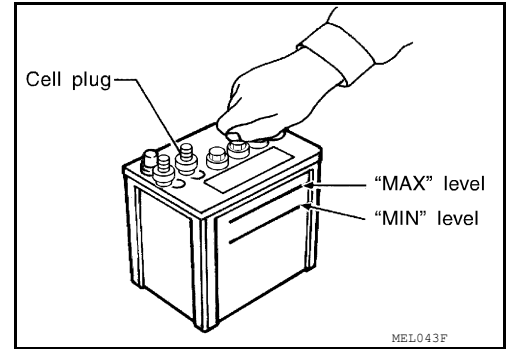

SULFATION

- **A battery will be completely discharged if it is left unattended for a long time and the specific gravity will become less than 1.100. This may result in sulfation on the cell plates.**
- **To determine if a battery has been “sulfated”, note its voltage and current when charging it. As shown in the figure, less current and higher voltage are observed in the initial stage of charging sulfated batteries.**
- **A sulfated battery may sometimes be brought back into service by means of a long, slow charge, 12 hours or more, followed by a battery capacity test.**

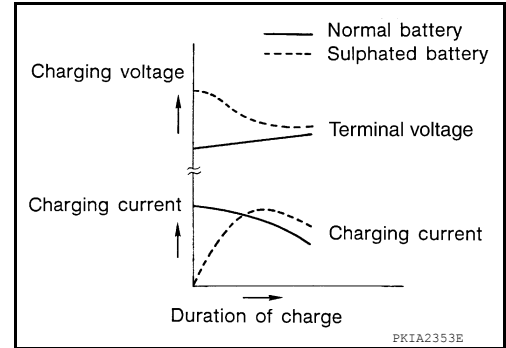

Specific Gravity Check

NOTE:

Check the charge condition of the battery.

Periodically check the specific gravity of the electrolyte. Keep a close check on charge condition to prevent over-discharge.

1. Read hydrometer and thermometer indications at eye level.
2. Use the chart below to correct your hydrometer reading according to electrolyte temperature.

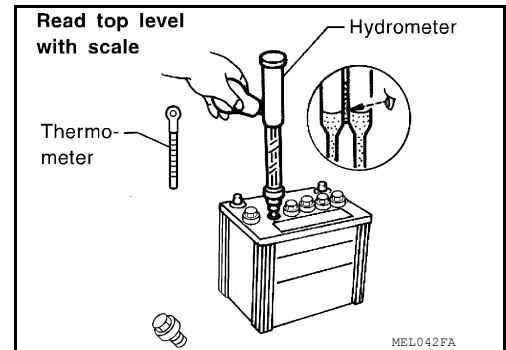

Hydrometer Temperature Correction

Battery electrolyte temperature [°C (°F)]	Add to specific gravity reading
71 (160)	0.032
66 (150)	0.028
60 (140)	0.024
54 (130)	0.020
49 (120)	0.016
43 (110)	0.012
38 (100)	0.008
32 (90)	0.004
27 (80)	0
21 (70)	-0.004
16 (60)	-0.008
10 (50)	-0.012

BATTERY

[COUPE]

< BASIC INSPECTION >

Battery electrolyte temperature [°C (°F)]	Add to specific gravity reading
4 (40)	-0.016
-1 (30)	-0.020
-7 (20)	-0.024
-12 (10)	-0.028
-18 (0)	-0.032

Corrected specific gravity	Approximate charge condition
1.260 - 1.280	Fully charged
1.230 - 1.250	3/4 charged
1.200 - 1.220	1/2 charged
1.170 - 1.190	1/4 charged
1.140 - 1.160	Almost discharged
1.110 - 1.130	Completely discharged

Charging The Battery

CAUTION:

- **Never “quick charge” a fully discharged battery.**
- **Keep the battery away from open flame while it is being charged.**
- **When connecting the charger, connect the leads first, then turn on the charger. Never turn on the charger first, as this may cause a spark.**
- **If battery electrolyte temperature rises above 55 °C (131 °F), stop charging. Always charge battery at a temperature below 55 °C (131 °F).**

Charging Rates (Standard Charge)

Approximate charge condition	Charge current (A)	Charge time (h)
Fully charged	7	2
3/4 charged		2.5
1/2 charged		5
1/4 charged		7.5
Almost discharged		9
Completely discharged		10

Charging Rates (Quick Charge)

Approximate charge condition	Charge current (A)	Charge time (h)
Fully charged	—	—
3/4 charged	16	0.5
1/2 charged	33	
1/4 charged		
Almost discharged	—	—
Completely discharged	—	

NOTE:

The ammeter reading on your battery charger will automatically decrease as the battery charges. This indicates that the voltage of the battery is increasing normally as the state of charge improves. The charging amps indicated above refer to initial charge rate.

- If, after charging, the specific gravity of any two cells varies more than 0.050, the battery should be replaced.

A
B
C
D
E
F
G
H
I
J
K
L
N
O
P

PG

INSPECTION AND ADJUSTMENT

< BASIC INSPECTION >

[COUPE]

INSPECTION AND ADJUSTMENT

ADDITIONAL SERVICE WHEN REMOVING BATTERY NEGATIVE TERMINAL

ADDITIONAL SERVICE WHEN REMOVING BATTERY NEGATIVE TERMINAL : Special Repair Requirement

INFOID:000000007419546

Required Procedure After Battery Disconnection

System	Item	Reference
Engine Control System	Idle Air Volume Learning	EC-20 (QR25DE) EC-335 (VQ35DE)
Power Window Control System	Power Window System Initialization	PWC-104
Roof	Sunroof Memory Reset/Initialization	RF-6
Heater & Air Conditioning Control System	Temperature Setting Trimmer	HAC-6
	Foot Position Setting Trimmer	HAC-6
	Inlet Port Memory Function	HAC-6
Audio, Visual & Navigation System	Audio (Radio Preset)	Refer to Owner's Manual.
	Navigation System	Refer to Owner's Manual.

POWER SUPPLY ROUTING CIRCUIT

< DTC/CIRCUIT DIAGNOSIS >

[COUPE]

DTC/CIRCUIT DIAGNOSIS

POWER SUPPLY ROUTING CIRCUIT

Wiring Diagram —Battery Power Supply—

INFOID:000000007419547

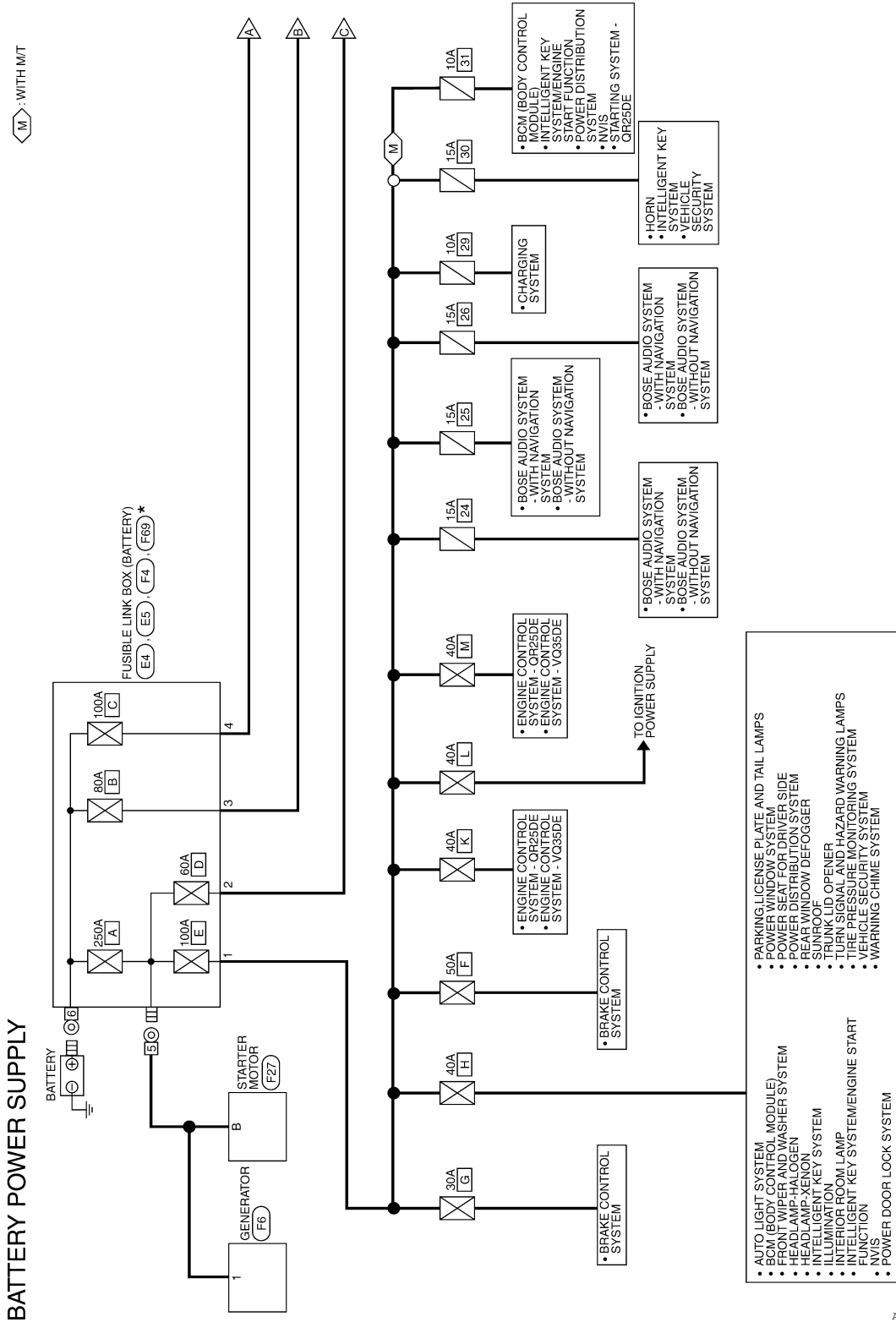

ABMWA0760GB

A
B
C
D
E
F
G
H
I
J
K
L
M
N
O
P



POWER SUPPLY ROUTING CIRCUIT

< DTC/CIRCUIT DIAGNOSIS >

[COUPE]

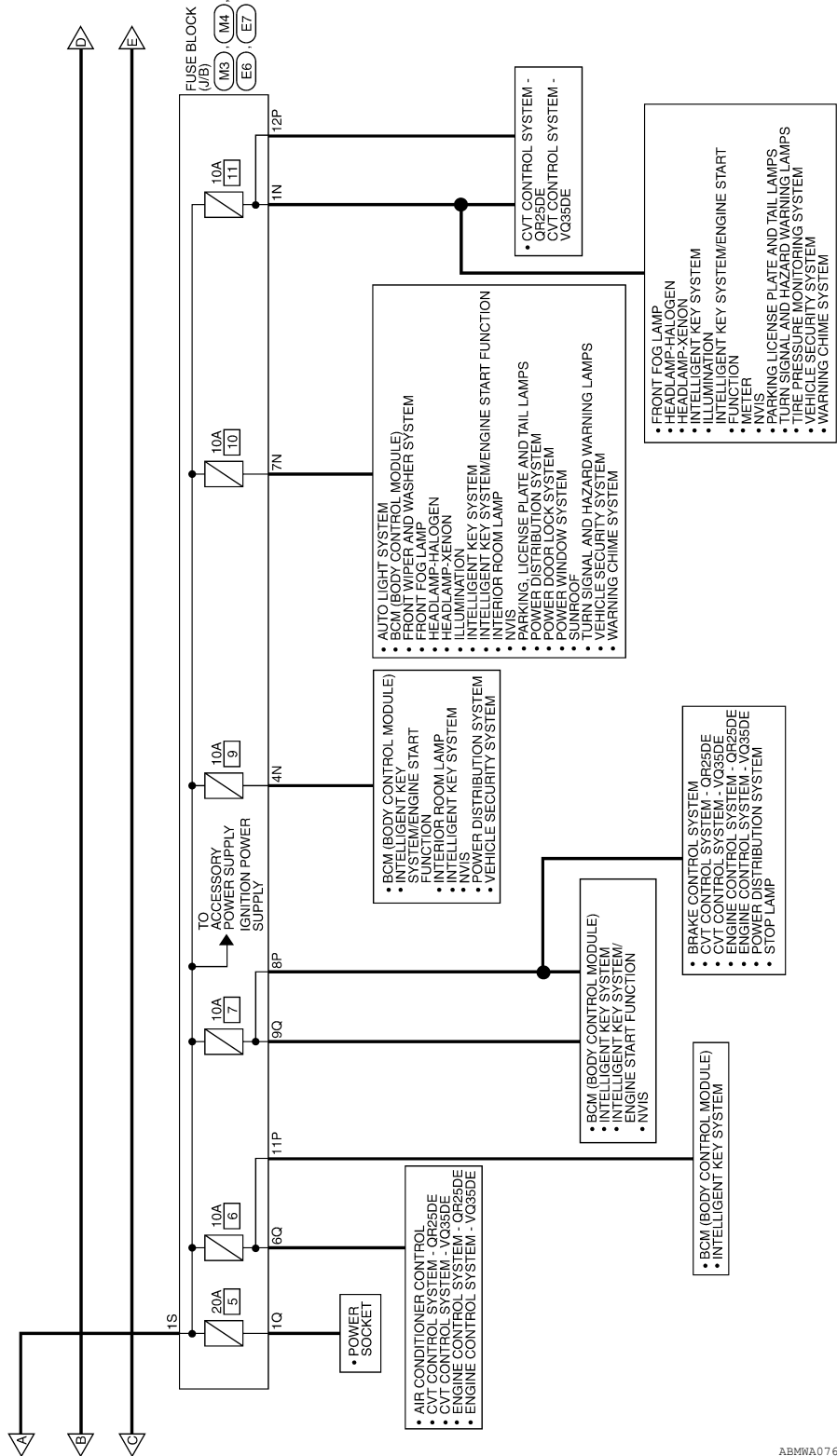

ABMWA0761GB

POWER SUPPLY ROUTING CIRCUIT

< DTC/CIRCUIT DIAGNOSIS >

[COUPE]

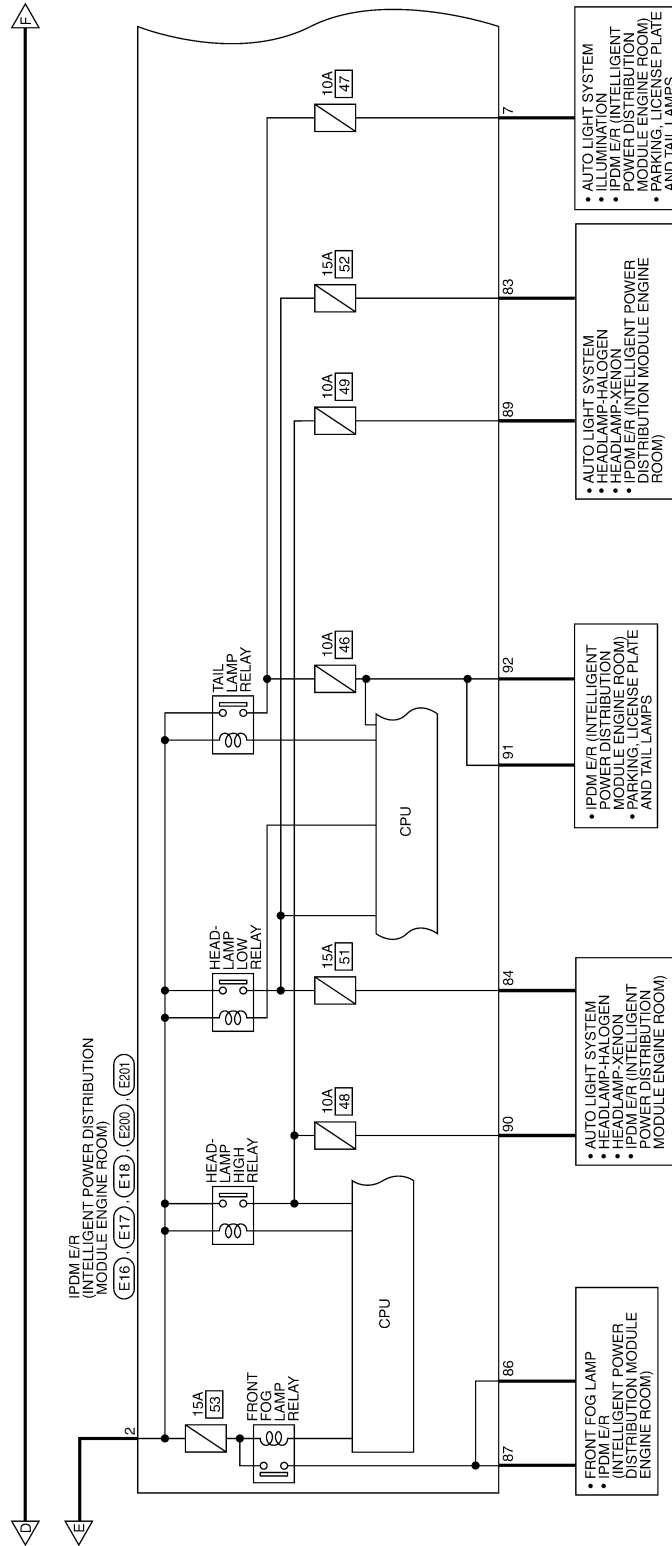

ABMWA0762GB

A
B
C
D
E
F
G
H
I
J
K
L
PG
N
O
P

POWER SUPPLY ROUTING CIRCUIT

< DTC/CIRCUIT DIAGNOSIS >

[COUPE]

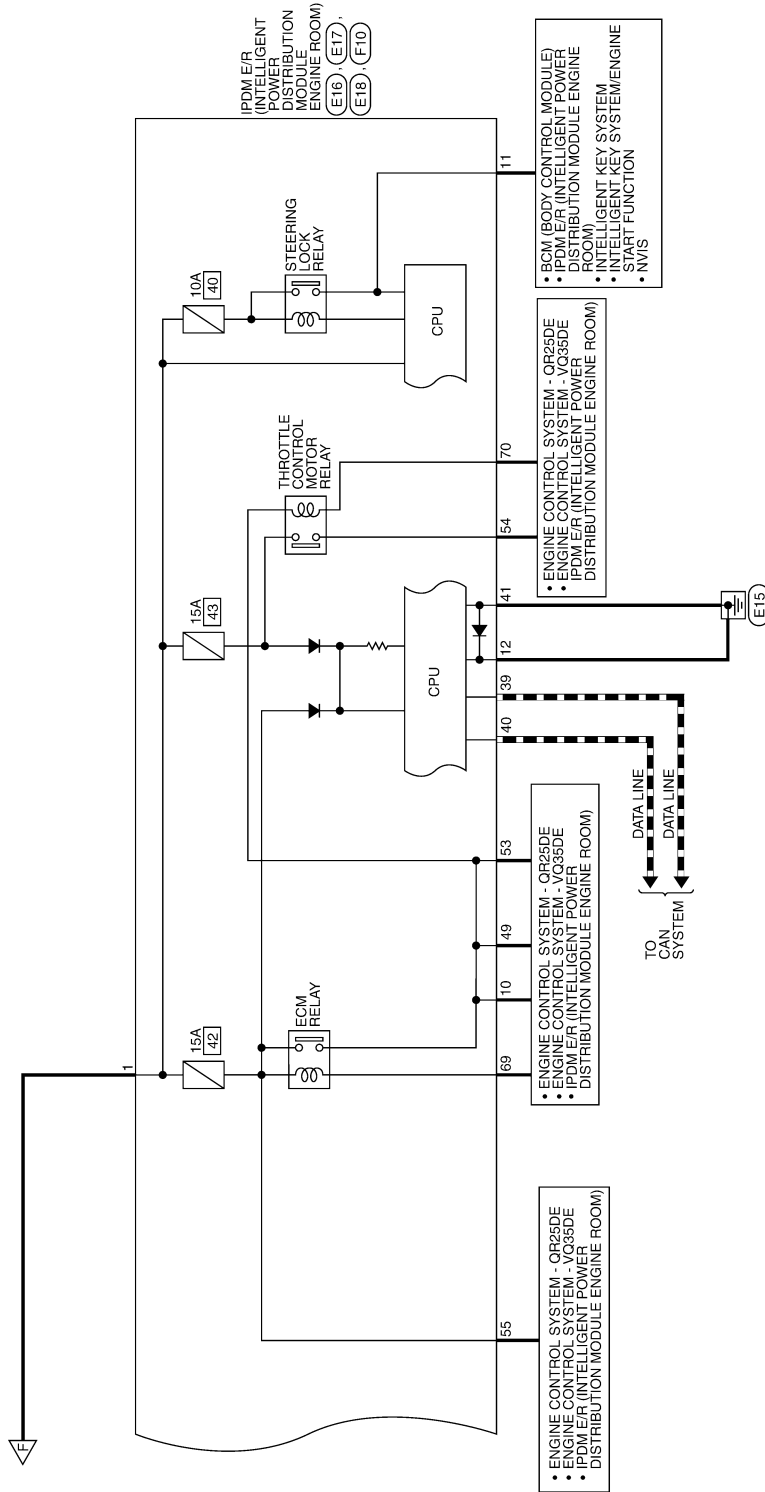

ABMWA0763GB

BATTERY POWER SUPPLY CONNECTORS

Connector No.	M3
Connector Name	FUSE BLOCK (J/B)
Connector Color	WHITE

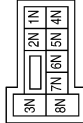

Terminal No.	Color of Wire	Signal Name
1N	W/L	-
4N	G/Y	-
7N	Y/R	-

Connector No.	M4
Connector Name	FUSE BLOCK (J/B)
Connector Color	WHITE

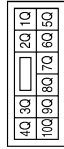

Terminal No.	Color of Wire	Signal Name
1Q	R/W	- (EARLY PRODUCTION)
1Q	L	- (LATE PRODUCTION)
6Q	Y/R	-
9Q	R/W	-

Connector No.	E4
Connector Name	FUSIBLE LINK BOX (BATTERY)
Connector Color	BROWN



Terminal No.	Color of Wire	Signal Name
1	B/W	-
2	L	-

Connector No.	E5
Connector Name	FUSIBLE LINK BOX (BATTERY)
Connector Color	GRAY



Terminal No.	Color of Wire	Signal Name
3	R	-
4	W	-

Connector No.	E6
Connector Name	FUSE BLOCK (J/B)
Connector Color	WHITE



Terminal No.	Color of Wire	Signal Name
8P	R	-
11P	G	-
12P	V	-

Connector No.	E7
Connector Name	FUSE BLOCK (J/B)
Connector Color	WHITE



Terminal No.	Color of Wire	Signal Name
1S	W	-

AAMIA0934GB

A
B
C
D
E
F
G
H
I
J
K
L
PG
N
O
P

POWER SUPPLY ROUTING CIRCUIT

< DTC/CIRCUIT DIAGNOSIS >

[COUPE]

Connector No.	E16
Connector Name	IPDM E/R (INTELLIGENT POWER DISTRIBUTION MODULE ENGINE ROOM)
Connector Color	BLACK



Terminal No.	Color of Wire	Signal Name
1	R	F/L_MAIN
2	L	F/L_USM

Connector No.	E17
Connector Name	IPDM E/R (INTELLIGENT POWER DISTRIBUTION MODULE ENGINE ROOM)
Connector Color	WHITE

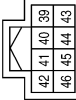

Terminal No.	Color of Wire	Signal Name
39	P	CAN-L
40	L	CAN-H
41	B	GND (SIGNAL)

Connector No.	E18
Connector Name	IPDM E/R (INTELLIGENT POWER DISTRIBUTION MODULE ENGINE ROOM)
Connector Color	WHITE

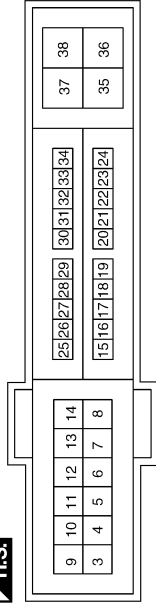

Terminal No.	Color of Wire	Signal Name
7	GR	TAIL/ILLUMI
10	BR	ECM_VB
11	O	ESCL
12	B	GND (POWER)

Connector No.	E200
Connector Name	IPDM E/R (INTELLIGENT POWER DISTRIBUTION MODULE ENGINE ROOM)
Connector Color	WHITE



Terminal No.	Color of Wire	Signal Name
83	R/Y	HEADLAMP_LO_RH
84	L	HEADLAMP_LO_LH
86	W/R	FR FOG LAMP RH
87	L/Y	FR FOG LAMP LH
89	L/W	HEADLAMP_HI_RH
90	G	HEADLAMP_HI_LH

Connector No.	E201
Connector Name	IPDM E/R (INTELLIGENT POWER DISTRIBUTION MODULE ENGINE ROOM)
Connector Color	WHITE

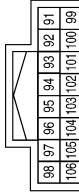

Terminal No.	Color of Wire	Signal Name
91	LG/R	CLEARANCE_RH
92	LG/B	CLEARANCE_LH

Connector No.	F4
Connector Name	FUSIBLE LINK BOX (BATTERY)
Connector Color	-



Terminal No.	Color of Wire	Signal Name
5	B/R	-

POWER SUPPLY ROUTING CIRCUIT

< DTC/CIRCUIT DIAGNOSIS >

[COUPE]

Connector No.	F27
Connector Name	STARTER MOTOR
Connector Color	-



Terminal No.	Color of Wire	Signal Name
B	B/R	BATT

Connector No.	F10
Connector Name	IPDM E/R (INTELLIGENT POWER DISTRIBUTION MODULE ENGINE ROOM)
Connector Color	WHITE

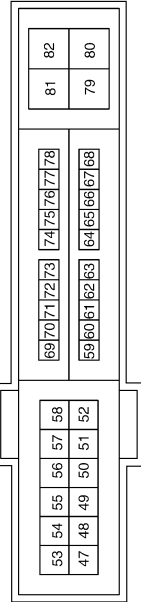

Terminal No.	Color of Wire	Signal Name
49	V	ENG SOL (WITH QR25DE)
49	V	IGN SOL (WITH VG35DE)
53	V	IGN SOL (WITH QR25DE)
53	G	ENG SOL (WITH VG35DE)
54	GR	ETC
55	LG	ECM BAT
69	SB	SSOF
70	G	MOTRLY

Connector No.	F6
Connector Name	GENERATOR
Connector Color	-

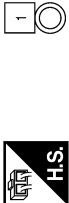

Terminal No.	Color of Wire	Signal Name
1	B/R	BATT

A
B
C
D
E
F
G
H
I
J
K
L
PG
N
O
P

ABMIA1978GB

POWER SUPPLY ROUTING CIRCUIT

[COUPE]

< DTC/CIRCUIT DIAGNOSIS >

Wiring Diagram —Accessory Power Supply—

INFOID:000000007419548

ACCESSORY POWER SUPPLY

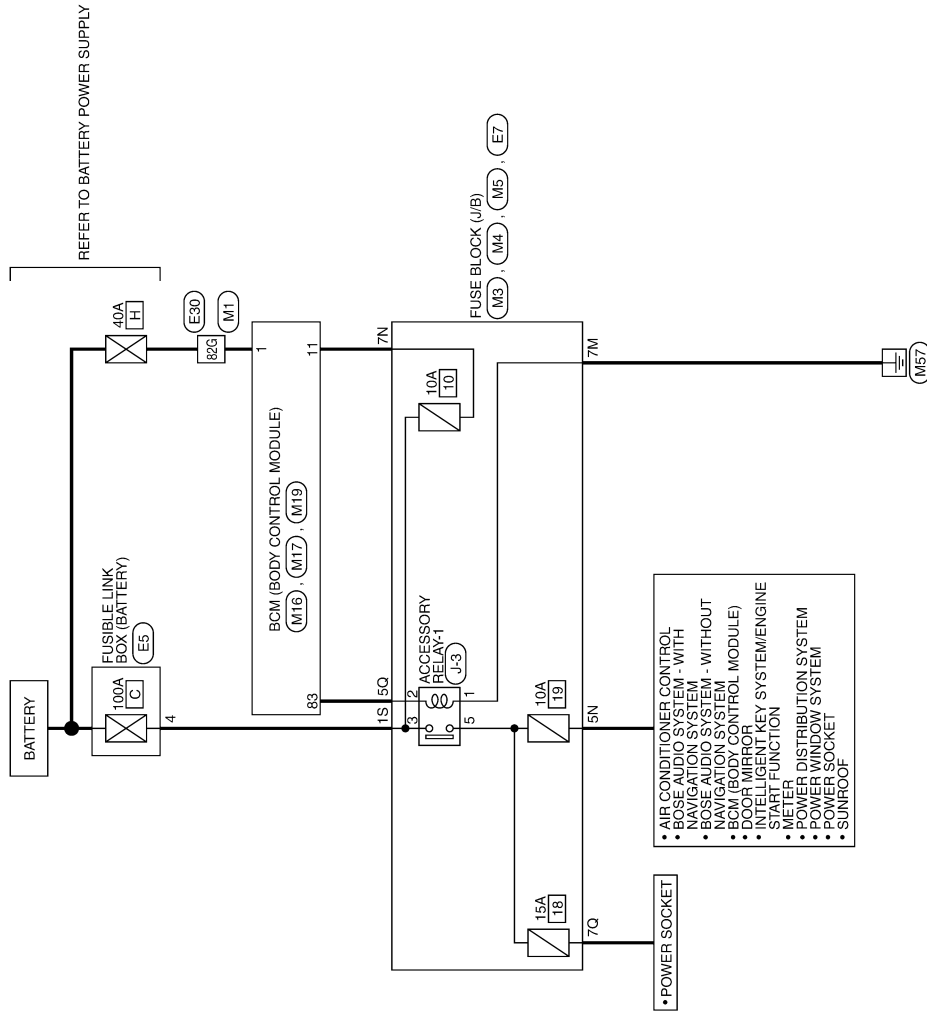

ABMWA1964GB

ACCESSORY POWER SUPPLY CONNECTORS

Connector No.	M1
Connector Name	WIRE TO WIRE
Connector Color	WHITE

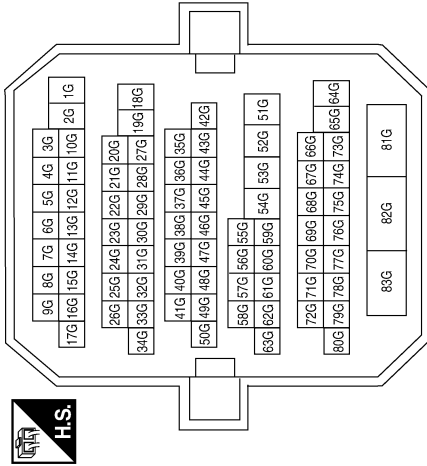

Terminal No.	Color of Wire	Signal Name
82G	W/B	-

Connector No.	M3
Connector Name	FUSE BLOCK (J/B)
Connector Color	WHITE

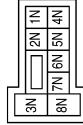

Terminal No.	Color of Wire	Signal Name
5N	V/Y	-
7N	Y/R	-

Connector No.	M4
Connector Name	FUSE BLOCK (J/B)
Connector Color	WHITE

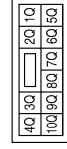

Terminal No.	Color of Wire	Signal Name
5Q	L	-
7Q	R/B	-

Connector No.	M5
Connector Name	FUSE BLOCK (J/B)
Connector Color	WHITE

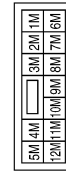

Terminal No.	Color of Wire	Signal Name
7M	B	-

Connector No.	M16
Connector Name	BCM (BODY CONTROL MODULE)
Connector Color	BLACK



Terminal No.	Color of Wire	Signal Name
1	W/B	BAT_POWER_F/L

Connector No.	M17
Connector Name	BCM (BODY CONTROL MODULE)
Connector Color	WHITE

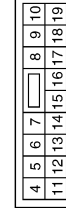

Terminal No.	Color of Wire	Signal Name
11	Y/R	BAT_BCM_FUSE

ABMIA0726GB

A
B
C
D
E
F
G
H
I
J
K
L
N
O
P

POWER SUPPLY ROUTING CIRCUIT

< DTC/CIRCUIT DIAGNOSIS >

[COUPE]

Connector No.	E7
Connector Name	FUSE BLOCK (J/B)
Connector Color	WHITE



Terminal No.	1S	Color of Wire	W	Signal Name	-
--------------	----	---------------	---	-------------	---

Connector No.	E5
Connector Name	FUSIBLE LINK BOX (BATTERY)
Connector Color	GRAY



Terminal No.	4	Color of Wire	W	Signal Name	-
--------------	---	---------------	---	-------------	---

Connector No.	M19
Connector Name	BCM (BODY CONTROL MODULE)
Connector Color	BLACK



79	78	77	76	75	74	73	72	71	70	69	68	67	66	65	64	63	62	61	60	59	58	57	56	55	54	53	52	51	50	49	48	47	46	45	44	43	42	41	40	39	38	37	36	35	34	33	32	31	30	29	28	27	26	25	24	23	22	21	20	19	18	17	16	15	14	13	12	11	10	9	8	7	6	5	4	3	2	1
----	----	----	----	----	----	----	----	----	----	----	----	----	----	----	----	----	----	----	----	----	----	----	----	----	----	----	----	----	----	----	----	----	----	----	----	----	----	----	----	----	----	----	----	----	----	----	----	----	----	----	----	----	----	----	----	----	----	----	----	----	----	----	----	----	----	----	----	----	----	---	---	---	---	---	---	---	---	---

Terminal No.	L	Color of Wire	L	Signal Name	ACC_CONT
--------------	---	---------------	---	-------------	----------

Connector No.	J-3
Connector Name	FUSE BLOCK (J/B) (ACCESSORY RELAY-1)
Connector Color	-

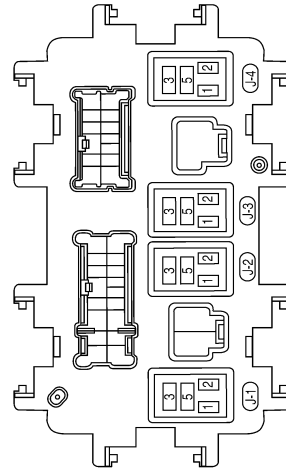

Connector No.	E30
Connector Name	WIRE TO WIRE
Connector Color	WHITE

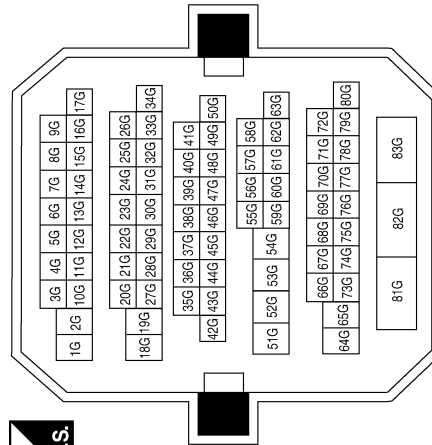

Terminal No.	LG	Color of Wire	LG	Signal Name	-
--------------	----	---------------	----	-------------	---

ABMIA4555GB

POWER SUPPLY ROUTING CIRCUIT

< DTC/CIRCUIT DIAGNOSIS >

[COUPE]

Wiring Diagram — Ignition Power Supply —

INFOID:000000007419549

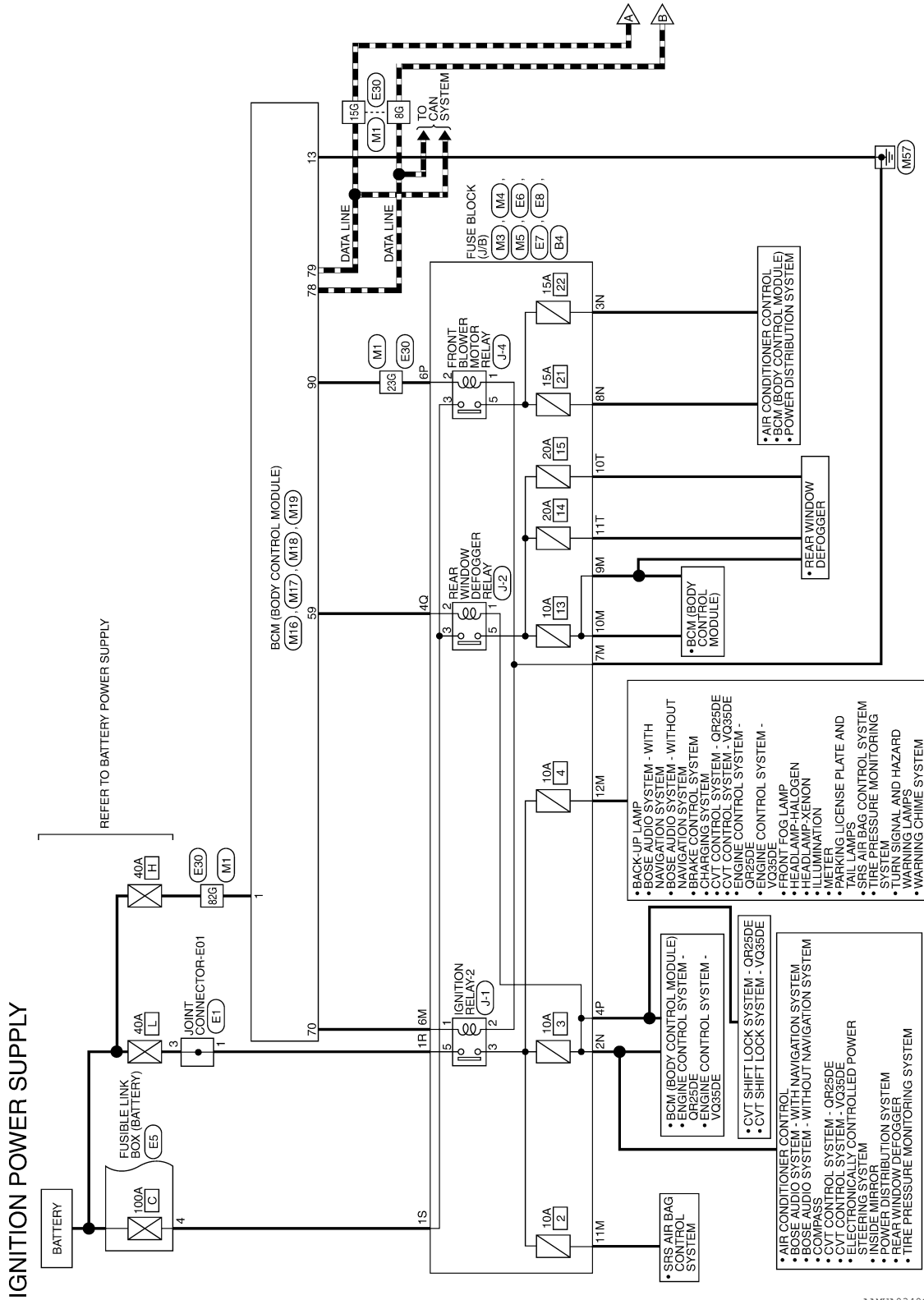

AAMWA0340GB

A
B
C
D
E
F
G
H
I
J
K
L
PG
N
O
P

POWER SUPPLY ROUTING CIRCUIT

< DTC/CIRCUIT DIAGNOSIS >

[COUPE]

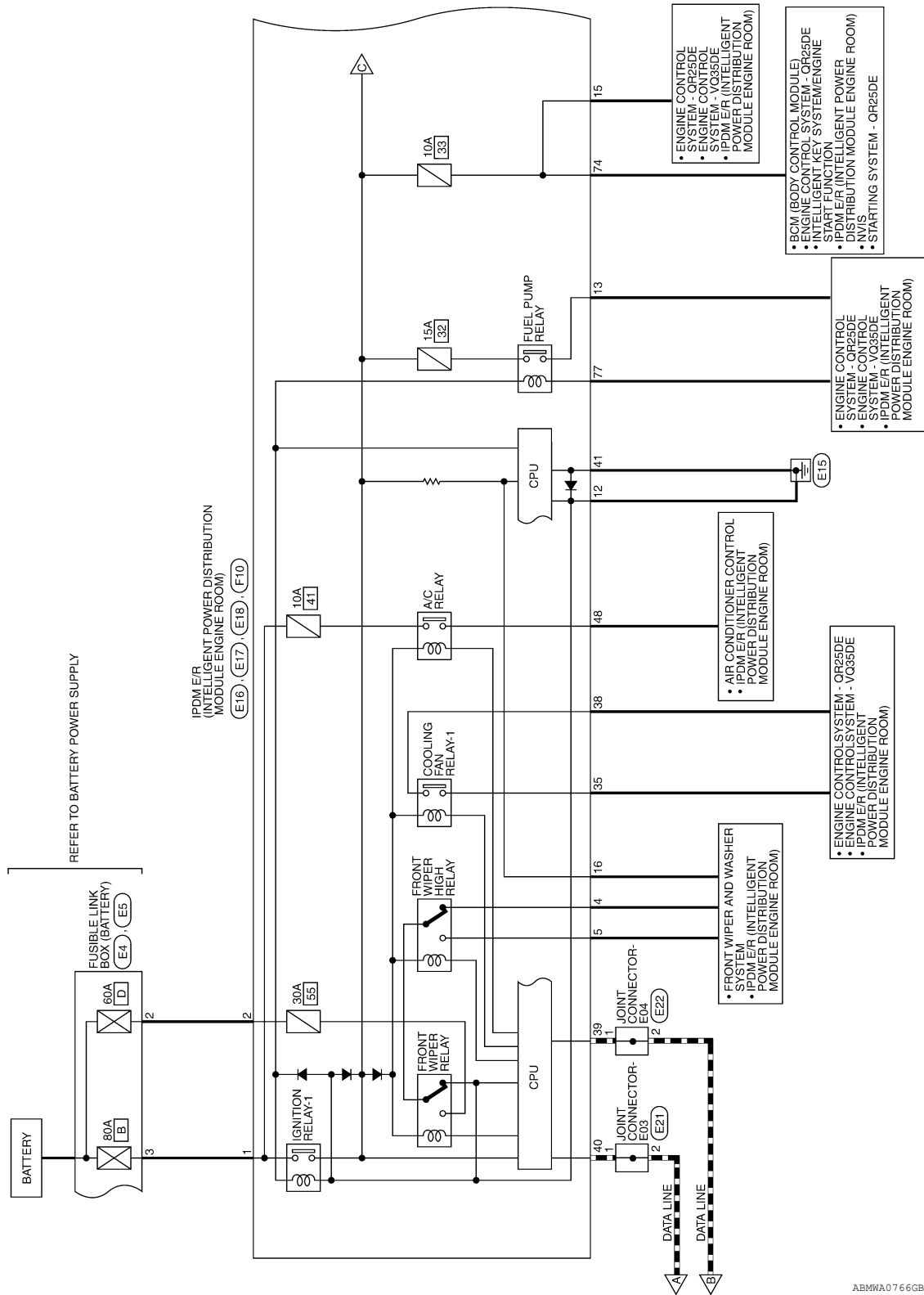

ABMWA0766GB

POWER SUPPLY ROUTING CIRCUIT

< DTC/CIRCUIT DIAGNOSIS >

[COUPE]

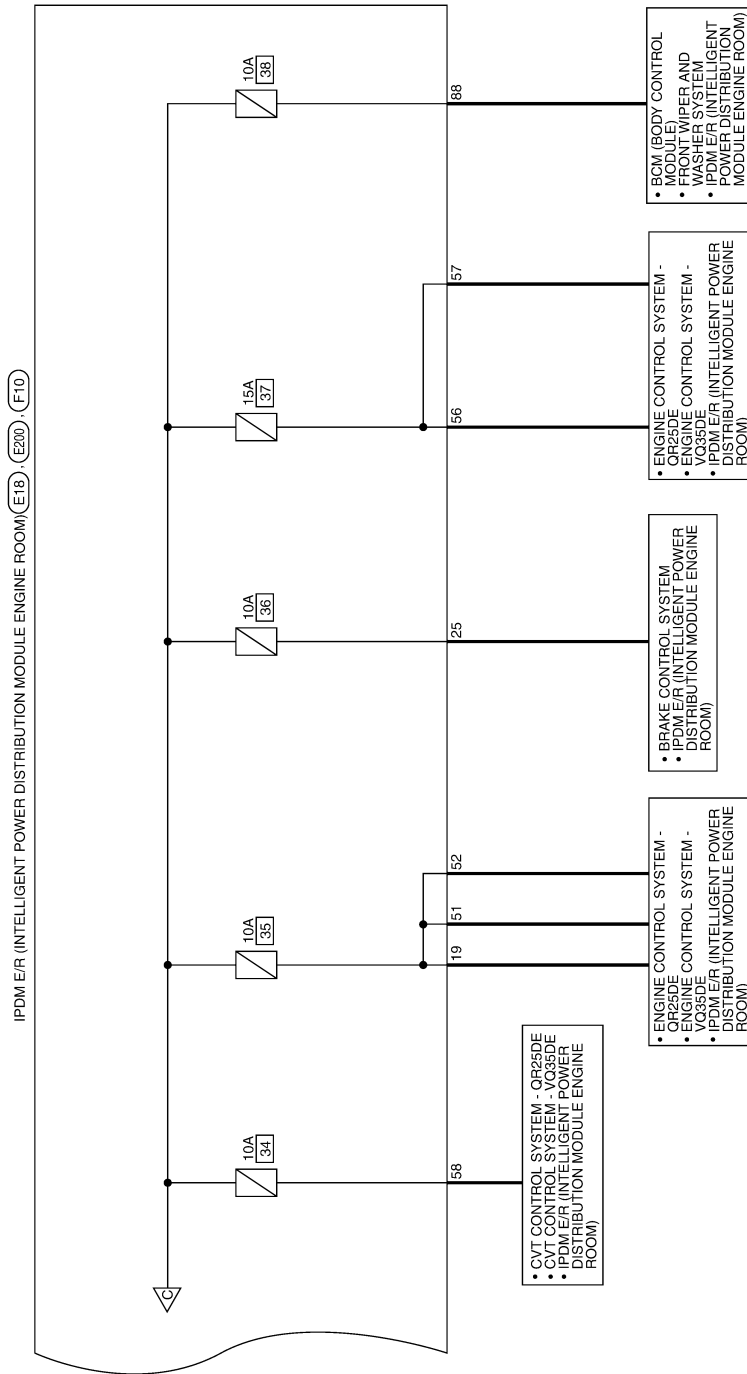

A
B
C
D
E
F
G
H
I
J
K
L
PG
N
O
P

AAMWA0341GB

IGNITION POWER SUPPLY CONNECTORS

Connector No.	M1
Connector Name	WIRE TO WIRE
Connector Color	WHITE

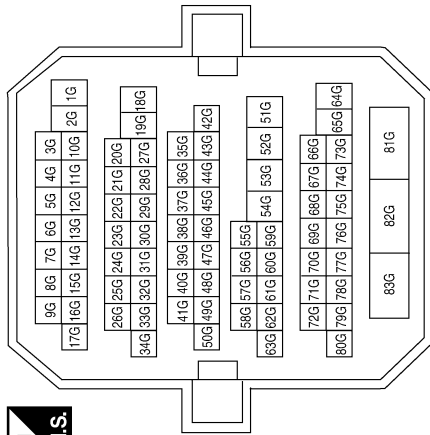

Terminal No.	Color of Wire	Signal Name
8G	P	-
15G	L	-
23G	Y	-
82G	W/B	-

Connector No.	M3
Connector Name	FUSE BLOCK (J/B)
Connector Color	WHITE

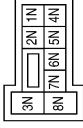

Terminal No.	Color of Wire	Signal Name
2N	G	-
3N	W/L	-
8N	W/L	-

Connector No.	M4
Connector Name	FUSE BLOCK (J/B)
Connector Color	WHITE

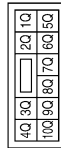

Terminal No.	Color of Wire	Signal Name
4Q	G/R	-

Connector No.	M5
Connector Name	FUSE BLOCK (J/B)
Connector Color	WHITE

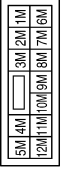

Terminal No.	Color of Wire	Signal Name
6M	R/B	-
7M	B	-
9M	GR	-
10M	L/Y	-
11M	R/L	-
12M	O	-

Connector No.	M16
Connector Name	BCM (BODY CONTROL MODULE)
Connector Color	BLACK



Terminal No.	Color of Wire	Signal Name
1	W/B	BAT_POWER_F/L

POWER SUPPLY ROUTING CIRCUIT

< DTC/CIRCUIT DIAGNOSIS >

[COUPE]

Connector No.	M19
Connector Name	BCM (BODY CONTROL MODULE)
Connector Color	BLACK

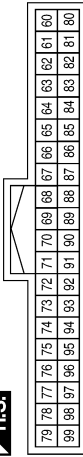
79	78	77	76	75	74	73	72	71	70	69	68	67	66	65	64	63	62	61	60
59	98	97	96	95	94	93	92	91	90	89	88	87	86	85	84	83	82	81	80

Terminal No.	Color of Wire	Signal Name
70	R/B	IGN_ELEC_CONT
78	P	CAN-L
79	L	CAN-H
90	Y	IGN2_CONT

Connector No.	M18
Connector Name	BCM (BODY CONTROL MODULE)
Connector Color	GREEN

39	38	37	36	35	34	33	32	31	30	29	28	27	26	25	24	23	22	21	20
59	58	57	56	55	54	53	52	51	50	49	48	47	46	45	44	43	42	41	40

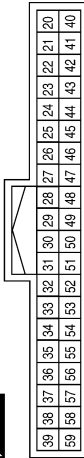
Terminal No.	Color of Wire	Signal Name
59	G/R	REAR_DEFGGER_RLY

Connector No.	M17
Connector Name	BCM (BODY CONTROL MODULE)
Connector Color	WHITE

4	5	6	7	8	9	10		
11	12	13	14	15	16	17	18	19

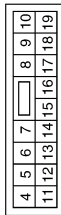

Terminal No.	Color of Wire	Signal Name
13	B	GND1

Connector No.	E5
Connector Name	FUSIBLE LINK BOX (BATTERY)
Connector Color	GRAY





Terminal No.	Color of Wire	Signal Name
3	R	-
4	W	-

Connector No.	E4
Connector Name	FUSIBLE LINK BOX (BATTERY)
Connector Color	BROWN

Terminal No.	Color of Wire	Signal Name
2	L	-

Connector No.	E1
Connector Name	JOINT CONNECTOR-E01
Connector Color	WHITE



Terminal No.	Color of Wire	Signal Name
1	G	-
3	G	-

ABMIA1981GB

A
B
C
D
E
F
G
H
I
J
K
L
N
O
P

PG

POWER SUPPLY ROUTING CIRCUIT

< DTC/CIRCUIT DIAGNOSIS >

[COUPE]

Connector No.	E8
Connector Name	FUSE BLOCK (J/B)
Connector Color	BLACK



Terminal No.	1R	Color of Wire	G	Signal Name	-
--------------	----	---------------	---	-------------	---

Connector No.	E7
Connector Name	FUSE BLOCK (J/B)
Connector Color	WHITE



Terminal No.	1S	Color of Wire	W	Signal Name	-
--------------	----	---------------	---	-------------	---

Connector No.	E6
Connector Name	FUSE BLOCK (J/B)
Connector Color	WHITE



Terminal No.	4P	Color of Wire	P	Signal Name	-
	6P		Y		-

Connector No.	E18
Connector Name	IPDM E/R (INTELLIGENT POWER DISTRIBUTION MODULE ENGINE ROOM)
Connector Color	WHITE

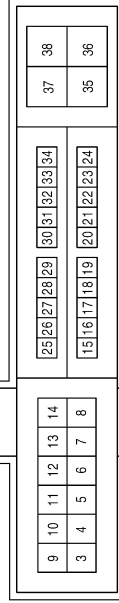

Connector No.	E17
Connector Name	IPDM E/R (INTELLIGENT POWER DISTRIBUTION MODULE ENGINE ROOM)
Connector Color	WHITE

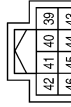

Terminal No.	Color of Wire	Signal Name
39	P	CAN-L
40	L	CAN-H
41	B	GND (SIGNAL)

Connector No.	E16
Connector Name	IPDM E/R (INTELLIGENT POWER DISTRIBUTION MODULE ENGINE ROOM)
Connector Color	BLACK



Terminal No.	Color of Wire	Signal Name
1	R	F/L_MAIN
2	L	F/L_USM

ABMIA3268GB

POWER SUPPLY ROUTING CIRCUIT

< DTC/CIRCUIT DIAGNOSIS >

[COUPE]

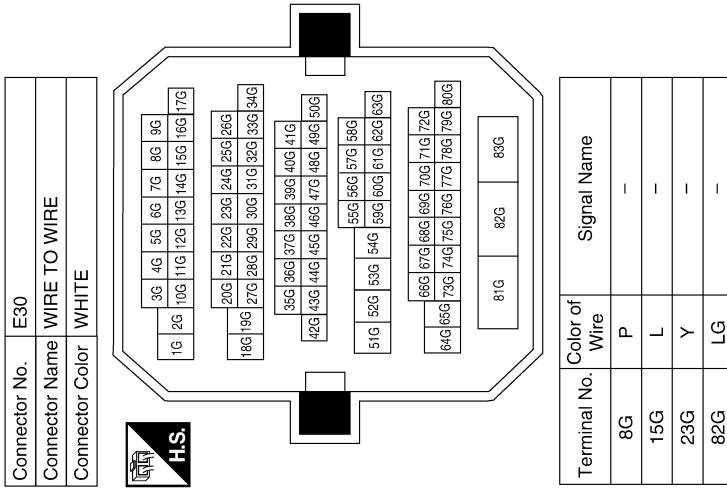

Connector No.	E22
Connector Name	JOINT CONNECTOR-E04
Connector Color	WHITE



Terminal No.	Color of Wire	Signal Name
1	P	-
2	P	-

Connector No.	E21
Connector Color	JOINT CONNECTOR-E03
Connector Name	WHITE



Terminal No.	Color of Wire	Signal Name
1	L	-
2	L	-

Connector No.	E200
Connector Name	IPDM E/R (INTELLIGENT POWER DISTRIBUTION MODULE ENGINE ROOM)
Connector Color	WHITE

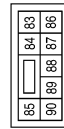

Terminal No.	Color of Wire	Signal Name
88	RW	WASHER_MTR

ABMIA0731GB

A
B
C
D
E
F
G
H
I
J
K
L
M
N
O
P

PG

POWER SUPPLY ROUTING CIRCUIT

< DTC/CIRCUIT DIAGNOSIS >

[COUPE]

Connector No.	B4
Connector Name	FUSE BLOCK (J/B)
Connector Color	BROWN

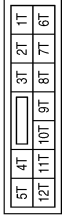

Terminal No.	Color of Wire	Signal Name
10T	Y	-
11T	Y	-

Terminal No.	Color of Wire	Signal Name
48	W	A/C_COMP
51	SB	INJECTOR_#1
52	Y	INJECTOR_#2
56	R	O2_SENS_#1
57	O	O2_SENS_#2
58	BR	AT_ECU
74	L	START_IG-EGI
77	B/R	FPR

Connector No.	F10
Connector Name	IPDM E/R (INTELLIGENT POWER DISTRIBUTION MODULE ENGINE ROOM)
Connector Color	WHITE

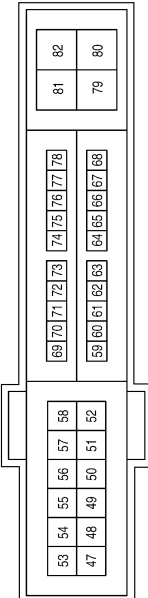

Connector No.	J-4
Connector Name	FUSE BLOCK (J/B) (REAR WINDOW DEFOGGER RELAY)
Connector Color	-

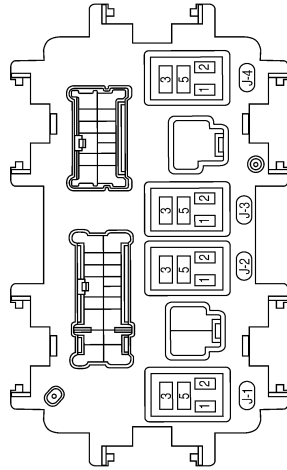

Connector No.	J-2
Connector Name	FUSE BLOCK (J/B) (REAR WINDOW DEFOGGER RELAY)
Connector Color	-

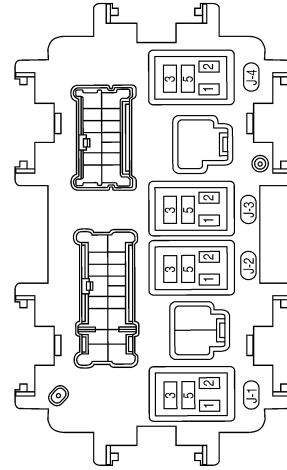

Connector No.	J-1
Connector Name	FUSE BLOCK (J/B) (IGNITION RELAY-2)
Connector Color	-

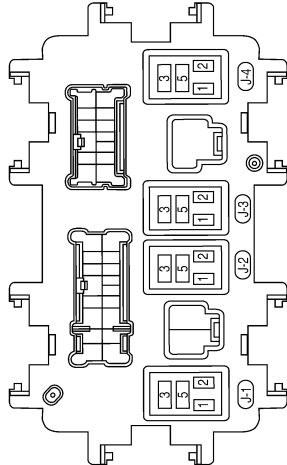

ABMIA3269GB

POWER SUPPLY ROUTING CIRCUIT

< DTC/CIRCUIT DIAGNOSIS >

[COUPE]

Fuse

INFOID:000000007419550

- If fuse is blown, be sure to eliminate cause of malfunction before installing new fuse.
- Use fuse of specified rating. Never use fuse of more than specified rating.
- Do not partially install fuse; always insert it into fuse holder properly.
- Remove fuse for "ELECTRICAL PARTS (BAT)" if vehicle is not used for a long period of time.

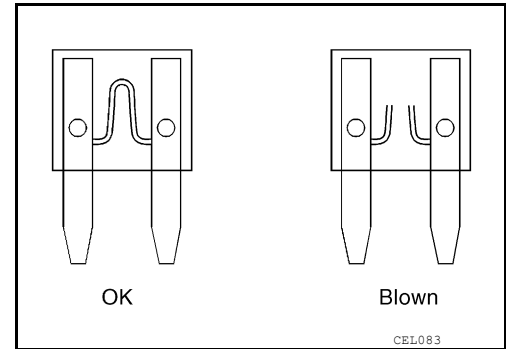

Fusible Link

INFOID:000000007419551

A melted fusible link can be detected either by visual inspection or by feeling with finger tip. If its condition is questionable, use circuit tester or test lamp.

1 : Fusible link

⇐ Front

CAUTION:

- If fusible link should melt, it is possible that critical circuit (power supply or large current carrying circuit) is shorted. In such a case, carefully check and eliminate cause of malfunction.
- Never wrap outside of fusible link with vinyl tape. Important: Never let fusible link touch any other wiring harness, vinyl or rubber parts.

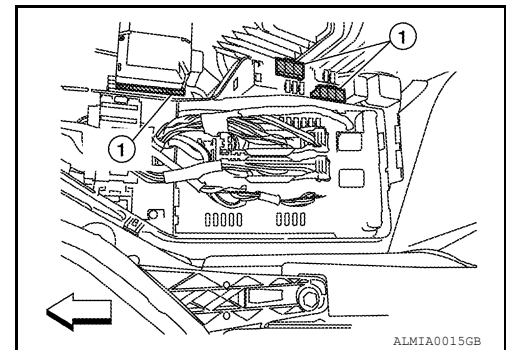

A
B
C
D
E
F
G
H
I
J
K
L
N
O
P

PG

GROUND

Ground Distribution

INFOID:000000007419552

MAIN HARNESS

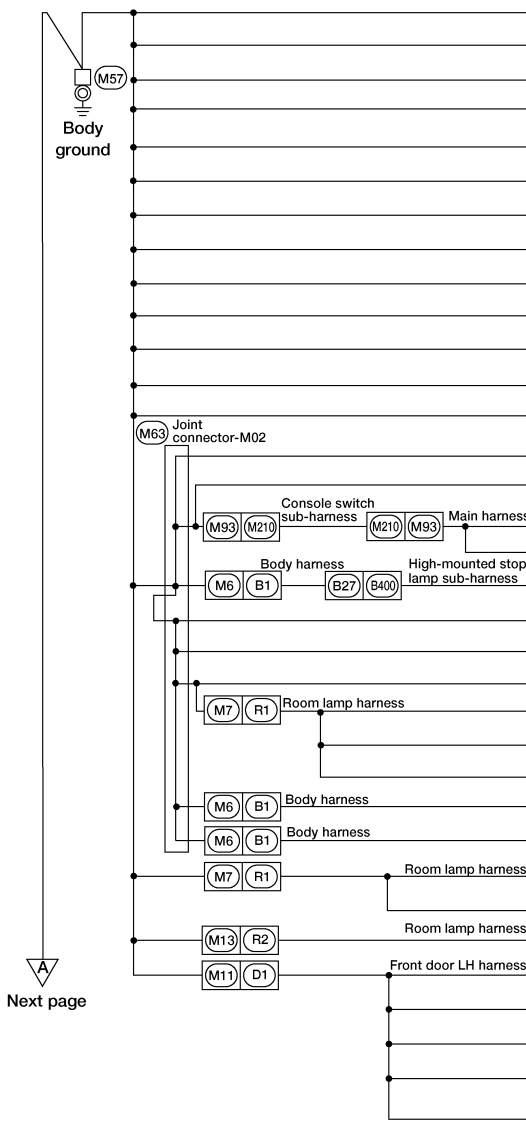
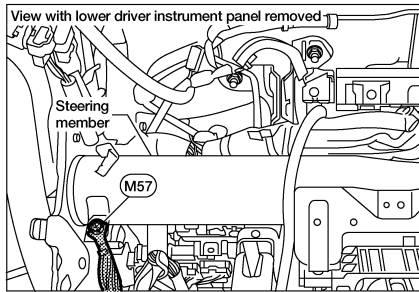

CONNECTOR NUMBER	CONNECT TO
(M5)	Fuse block (J/B)
(M17)	BCM (Body control module) (Terminal No. 13)
(M22)	Data link connector (Terminal No. 4)
(M22)	Data link connector (Terminal No. 5)
(M24)	Combination meter (Terminal No. 3)
(M24)	Combination meter (Terminal No. 4)
(M24)	Combination meter (Terminal No. 23)
(M28)	Combination switch
(M31)	Blower motor
(M40)	Key slot
(M45)	Audio unit (Terminal No. 48)
(M75)	Trunk lid opener switch
(M152)	Accessory relay-2 (late production)
(M44)	Audio unit (Terminal No. 20)
(M45)	Audio unit (Terminal No. 27)
(M103)	AV control unit (Terminal No. 77)
(M104)	AV control unit (Terminal No. 128)
(B401)	High-mounted stop lamp
(M53)	Steering angle sensor
(M55)	Yaw rate/side/decel G sensor
(M100)	AV control unit (Terminal No. 20)
(R3)	Vanity mirror lamp LH
(R4)	Auto anti-dazzling inside mirror
(R9)	Vanity mirror lamp RH
(B30)	Rear combination lamp LH
(B45)	Rear combination lamp RH
(R14)	Interior room lamp
(R50)	Front room/map lamp assembly
(R5)	Sunroof motor assembly
(D4)	Door mirror LH
(D5)	Door mirror remote control switch
(D6)	Outside handle LH
(D7)	Main power window and door lock/unlock switch (Terminal No. 15)
(D10)	Door lock assembly LH

Next page

ABMIA4556GB

GROUND

< DTC/CIRCUIT DIAGNOSIS >

[COUPE]

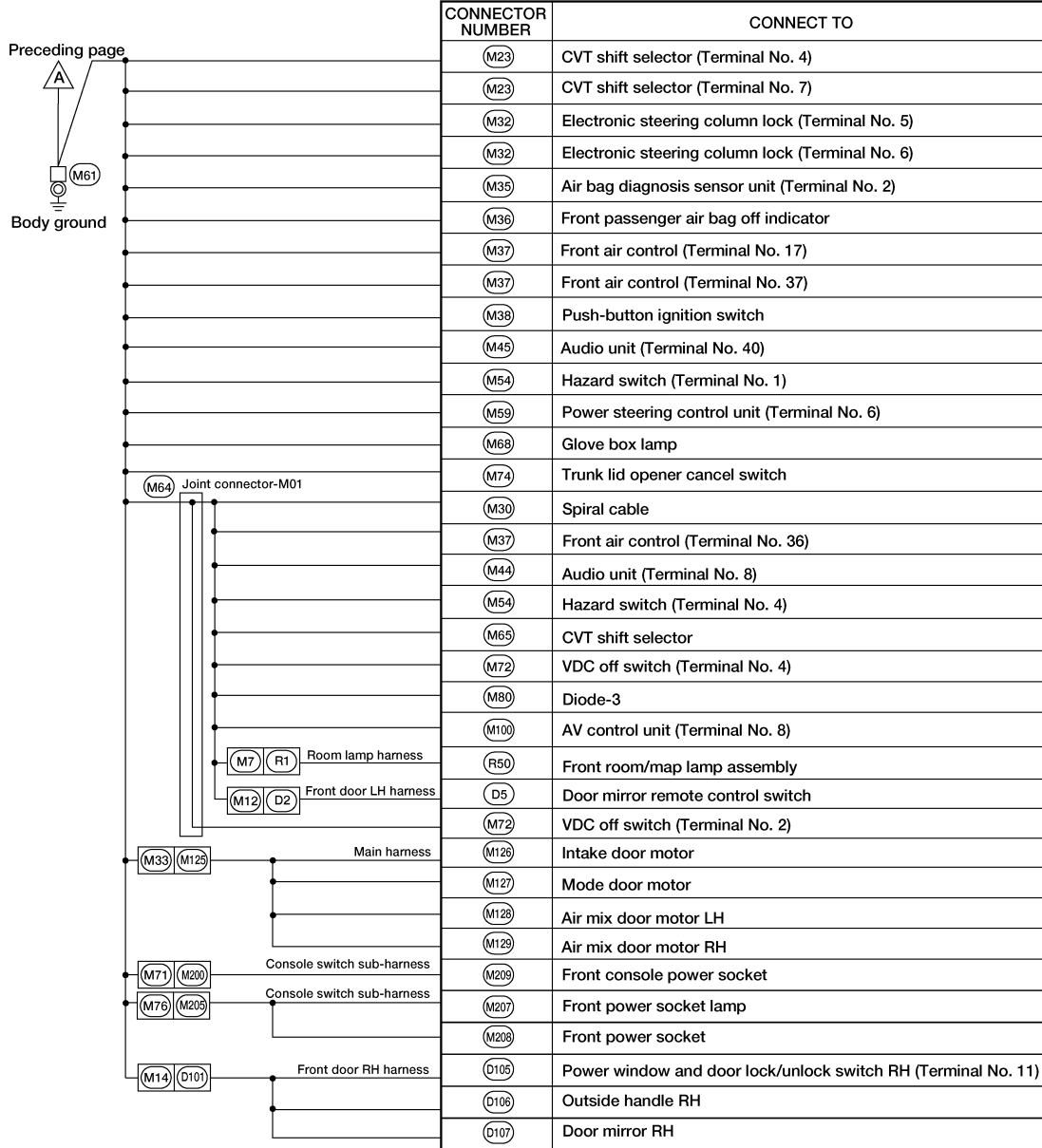
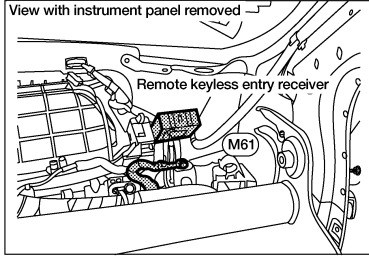

ABMIA4557GB

A
B
C
D
E
F
G
H
I
J
K
L
PG
N
O
P

< DTC/CIRCUIT DIAGNOSIS >

ENGINE ROOM HARNESS

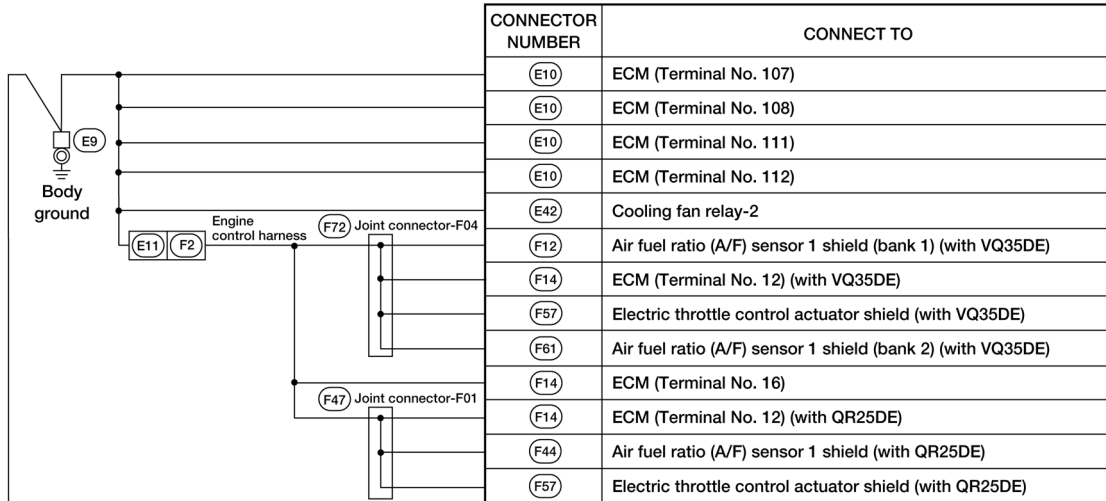
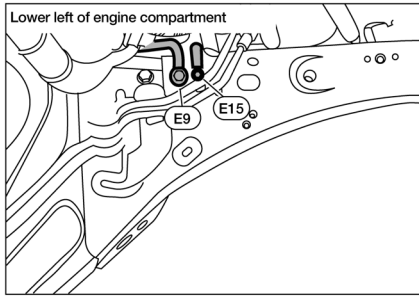

Next page

ABM1A1986GB

GROUND

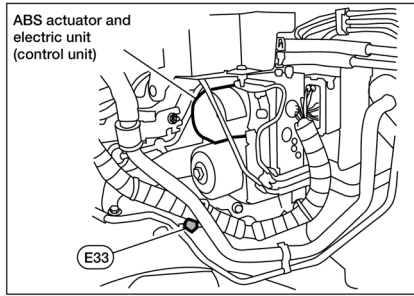
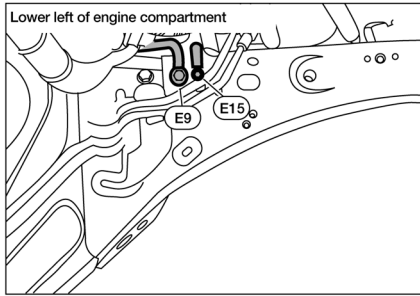

Preceding page

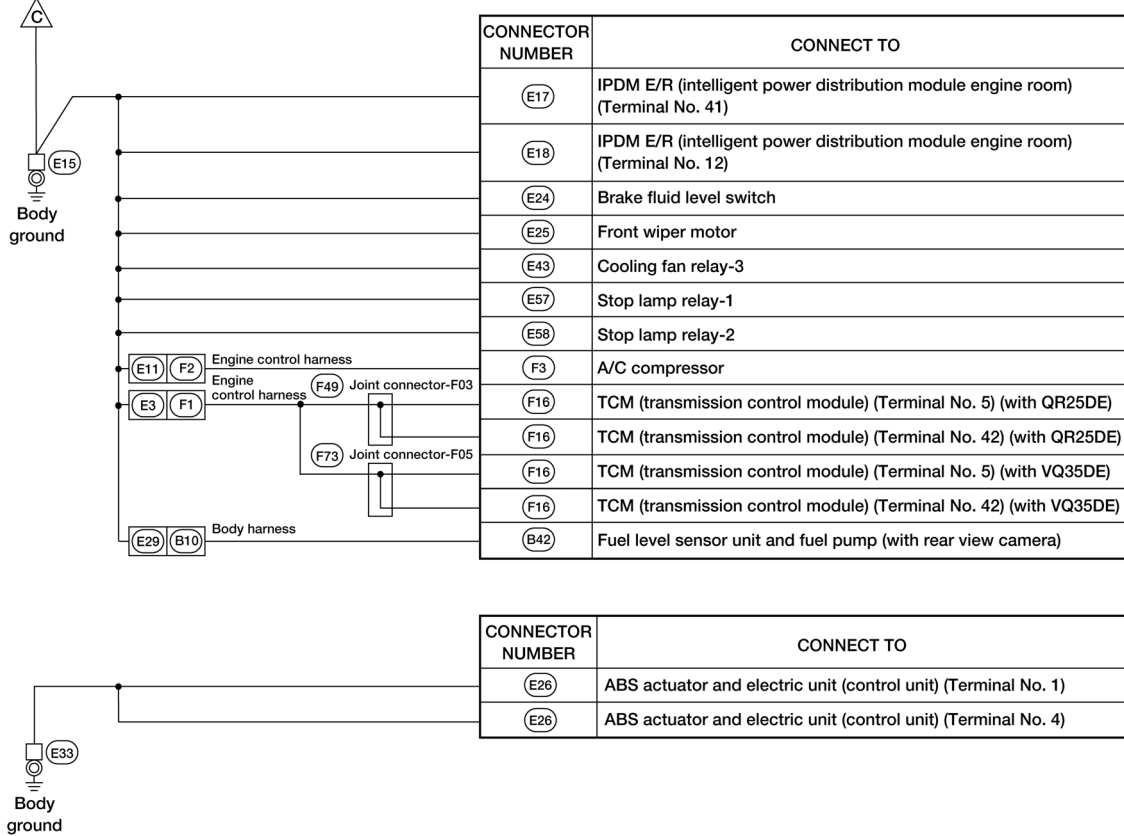

A
B
C
D
E
F
G
H
I
J
K
L
PG
N
O
P

GROUND

< DTC/CIRCUIT DIAGNOSIS >

[COUPE]

FRONT END MODULE HARNESS

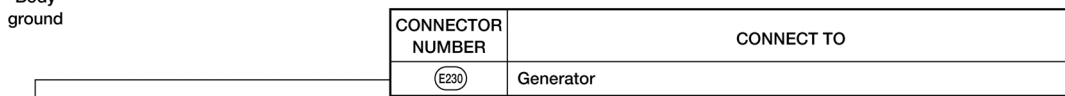
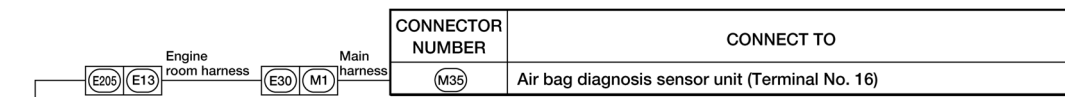
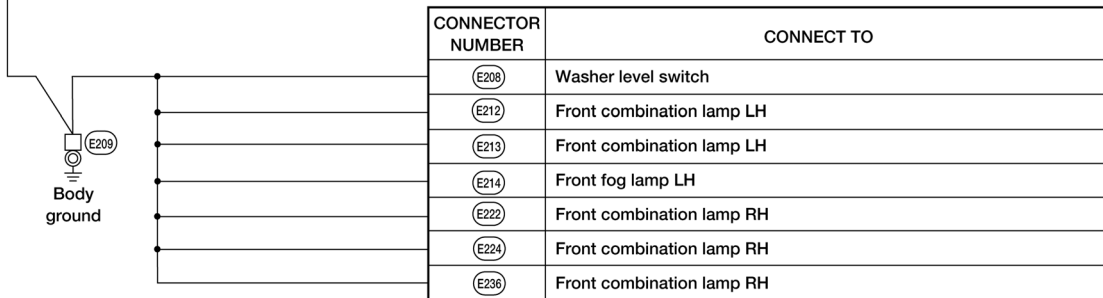
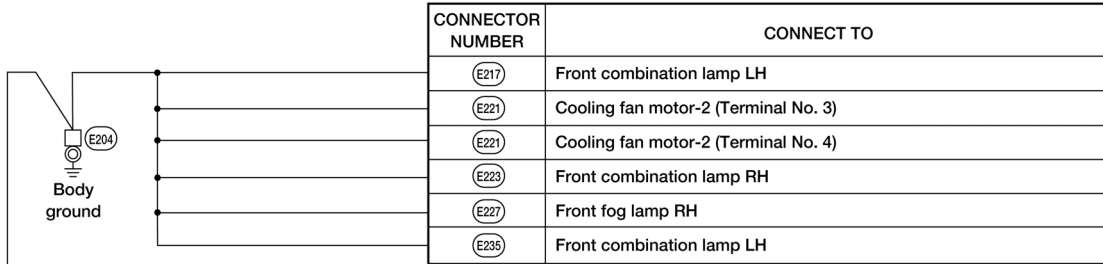
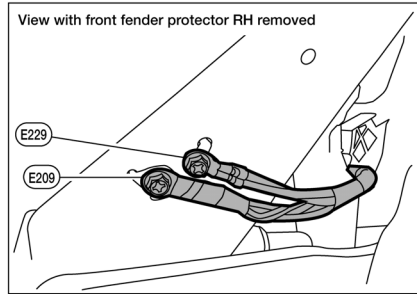
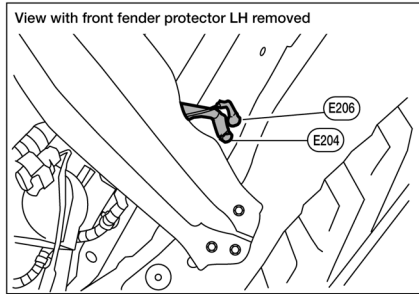

ABMIA1988GB

< DTC/CIRCUIT DIAGNOSIS >
ENGINE CONTROL HARNESS

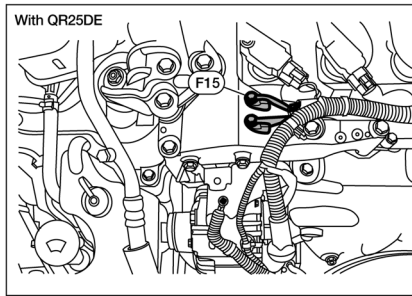
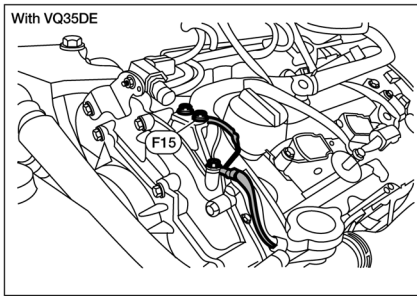

QR : With QR25DE
VQ : With VQ35DE

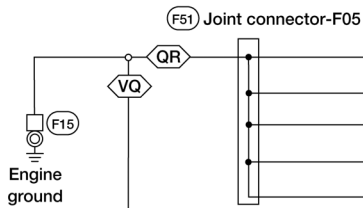

CONNECTOR NUMBER	CONNECT TO
F26	Condenser-2
F34	Ignition coil No. 1 (with power transistor)
F35	Ignition coil No. 2 (with power transistor)
F36	Ignition coil No. 3 (with power transistor)
F37	Ignition coil No. 4 (with power transistor)

CONNECTOR NUMBER	CONNECT TO
F26	Condenser-2
F34	Ignition coil No. 1 (with power transistor)
F35	Ignition coil No. 2 (with power transistor)
F36	Ignition coil No. 3 (with power transistor)
F37	Ignition coil No. 4 (with power transistor)
F38	Ignition coil No. 5 (with power transistor)
F39	Ignition coil No. 6 (with power transistor)

A
B
C
D
E
F
G
H
I
J
K
L
PG
N
O
P

ABMIA2659GB

BODY HARNESS

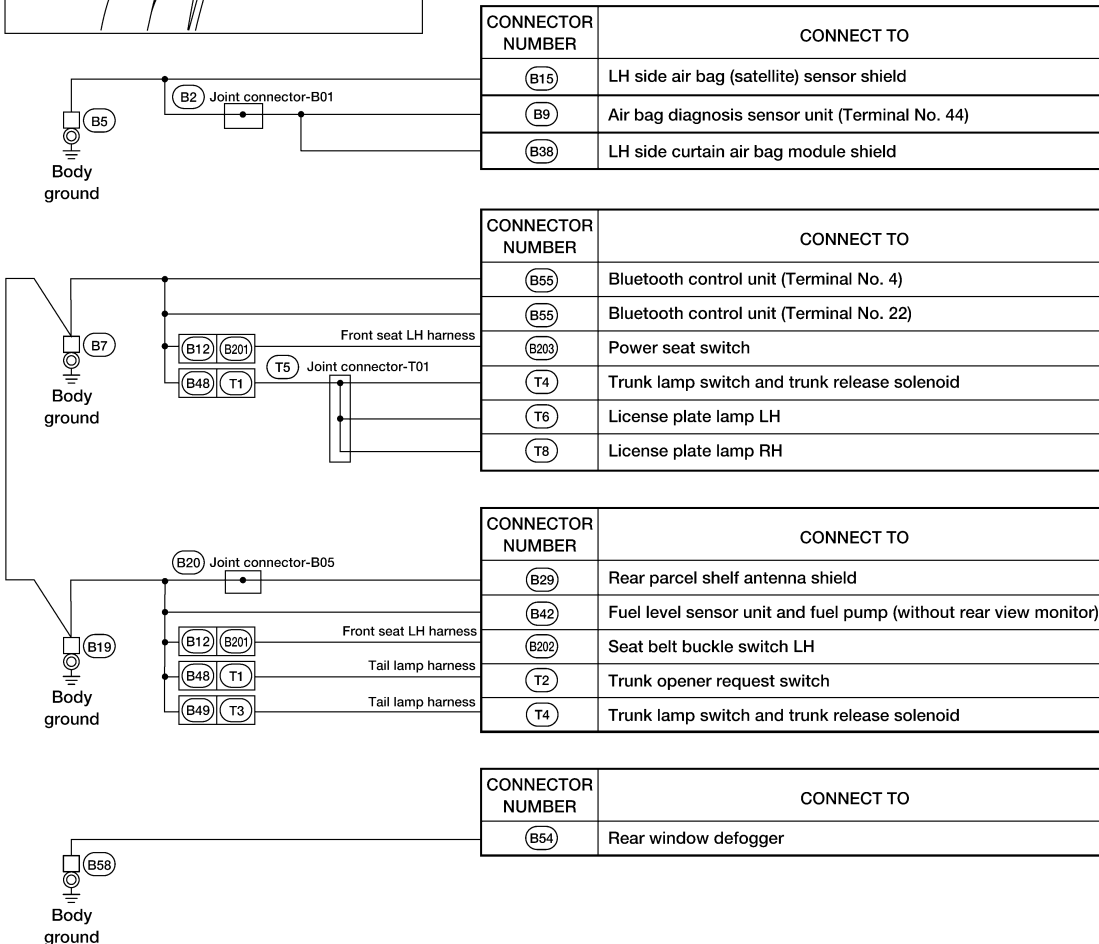
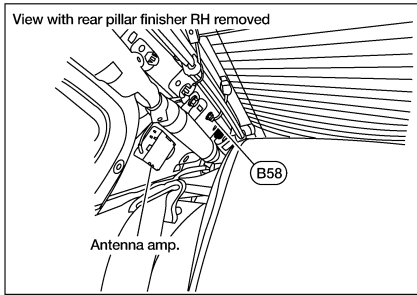
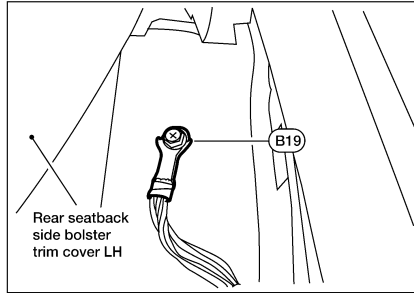
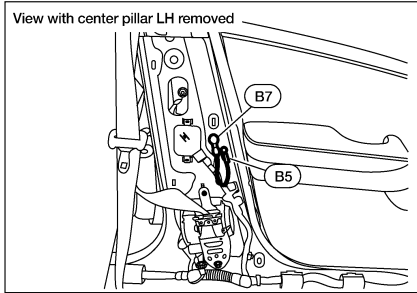

AAMIA0788GB

GROUND

[COUPE]

< DTC/CIRCUIT DIAGNOSIS >

BODY NO. 2 HARNESS

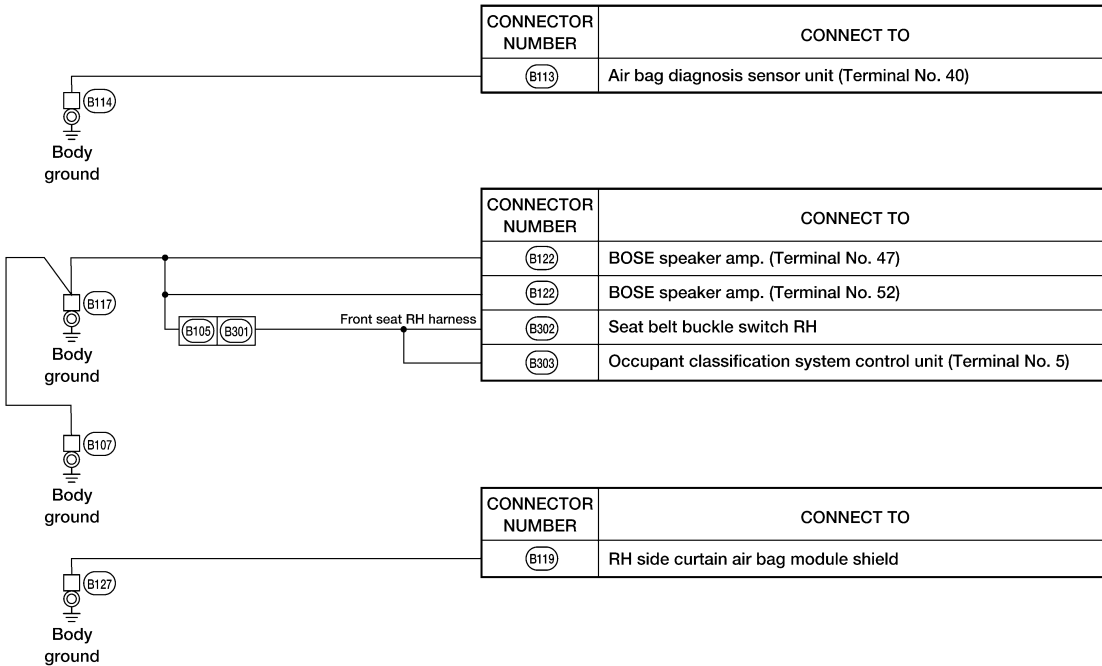
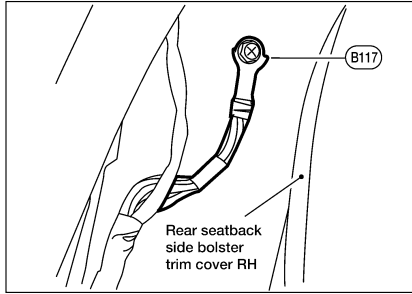
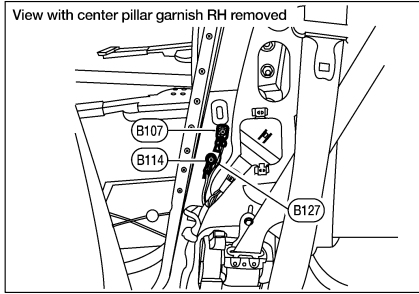

A
B
C
D
E
F
G
H
I
J
K
L
PG
N
O
P

AAMIA0789GB

HARNESS

Harness Layout

INFOID:000000007419553

HOW TO READ HARNESS LAYOUT

The following Harness Layouts use a map style grid to help locate connectors on the drawings:

- Main Harness and Console Switch Sub-harness
- Engine Room Harness
- Engine Room Harness (Passenger Compartment)
- Front End Module Harness
- Engine Control Harness (VQ35DE) and Knock Sensor Sub-harness
- Engine Control Harness (QR25DE)
- Body Harness, Tail lamp Sub-harness and Chassis Harness and High-mounted Stop Lamp Sub-harness
- Body No. 2 Harness
- Room Lamp Harness

To use the grid reference

1. Find the desired connector number on the connector list.
2. Find the grid reference.
3. On the drawing, find the crossing of the grid reference letter column and number row.
4. Find the connector number in the crossing zone.
5. Follow the line (if used) to the connector.

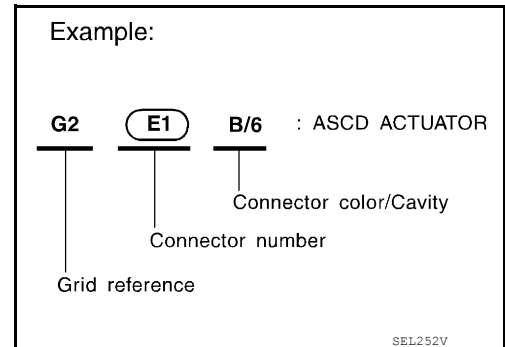

OUTLINE

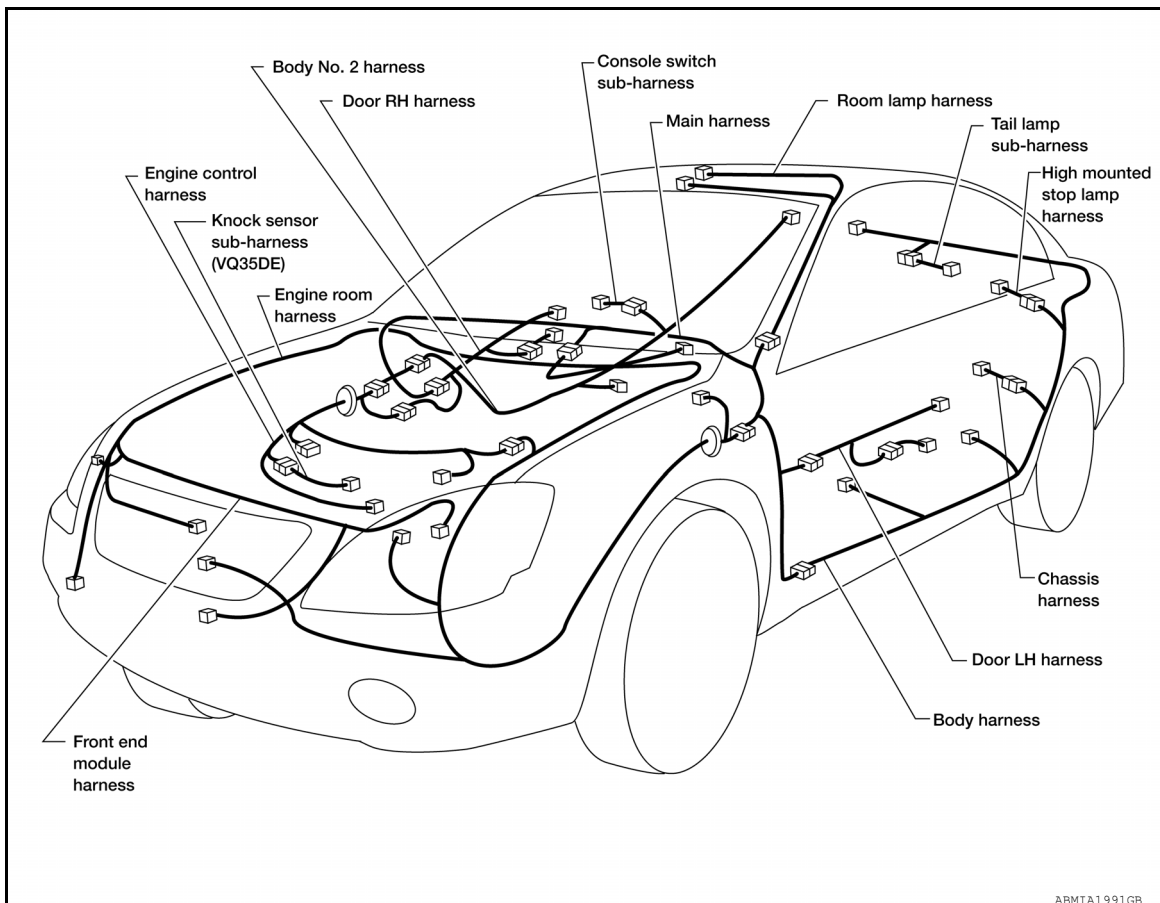

HARNESS

< DTC/CIRCUIT DIAGNOSIS >

[COUPE]

MAIN HARNESS

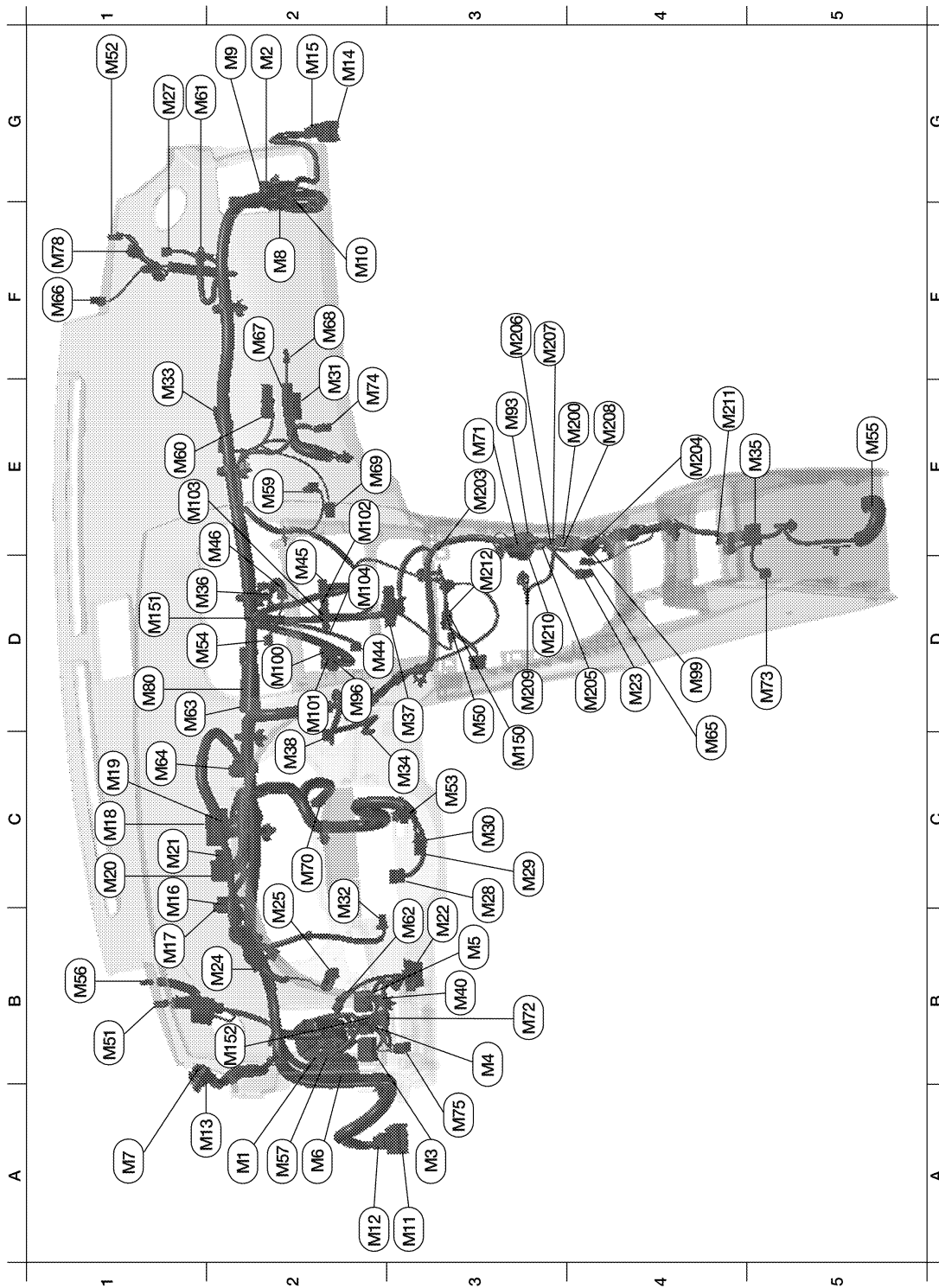

AAMIA0936GB

A2	M1	SMJ	: To E30	B1	M56	B/2	: Sunload sensor
G2	M2	W/32	: To B101	A2	M57	—	: Body ground
A3	M3	W/8	: Fuse block (J/B)	E2	M59	W/12	: Power steering control unit
B3	M4	W/10	: Fuse block (J/B)	E1	M60	Y/2	: Front passenger air bag module

HARNESSES

[COUPE]

< DTC/CIRCUIT DIAGNOSIS >

B3	M5	W/12	: Fuse block (J/B)	G1	M61	—	: Body ground
A2	M6	SMJ	: To B1	B2	M62	W/2	: Tire pressure warning check connector
A1	M7	W/16	: To R1	D1	M63	L/12	: Joint connector-M02
F2	M8	W/24	: To B102	C1	M64	GR/6	: Joint connector-M01
G2	M9	BR/16	: To B103	C4	M65	BR/2	: CVT shift selector
F2	M10	BR/12	: To B104	F1	M66	W/3	: Optical sensor
A3	M11	W/16	: To D1	F2	M67	O/2	: Front passenger air bag module
A2	M12	W/16	: To D2	F2	M68	W/2	: Glove box lamp
A2	M13	W/4	: To R2	E2	M69	W/4	: Intake sensor
G2	M14	W/10	: To D101	C2	M70	W/4	: Tire pressure receiver
G2	M15	W/12	: To D102	E3	M71	W/12	: To M200
C1	M16	B/3	: BCM (Body control module)	B3	M72	GR/6	: VDC OFF switch
B1	M17	W/16	: BCM (Body control module)	D5	M73	B/1	: Parking brake switch
C1	M18	G/40	: BCM (Body control module)	E2	M74	W/2	: Trunk lid opener cancel switch
C1	M19	B/40	: BCM (Body control module)	A3	M75	B/2	: Trunk lid opener switch
C1	M20	W/12	: BCM (Body control module)	E3	M76	W/3	: To M205
C1	M21	GR/40	: BCM (Body control module)	F1	M78	Y/4	: Front passenger air bag module (service replacement)
B3	M22	W/16	: Data link connector	D1	M80	—	: Diode-3
D4	M23	W/10	: CVT shift selector	D4	M84	W/3	: To M204
B2	M24	W/40	: Combination meter	E3	M85	W/2	: To M350
B2	M25	B/10	: Meter mode switch	E3	M93	W/12	: To M210
G1	M27	B/4	: Remote keyless entry receiver	D2	M96	G/4	: Audio unit
C3	M28	W/16	: Combination switch	D4	M99	G/6	: To M204
C3	M29	Y/6	: Spiral cable	D2	M100	W/20	: AV control unit
C3	M30	GR/8	: Spiral cable	D2	M101	G/4	: AV control unit
E2	M31	W/6	: Blower motor	E2	M102	W/32	: AV control unit
B2	M32	W/8	: Electronic steering column lock	E1	M103	W/40	: AV control unit
E1	M33	W/3	: To M125	D2	M104	W/28	: AV control unit
C2	M34	W/2	: In-vehicle sensor	D3	M150	W/2	: To M50
E4	M35	Y/28	: Air bag diagnosis sensor unit	D1	M151	BR/2	: Center speaker
D1	M36	W/3	: Front passenger air bag off indicator	B2	M152	L/4	: Accessory relay-2 (late production)
D2	M37	W/40	: Front air control	Console switch sub-harness			
C2	M38	BR/8	: Push-button ignition switch	E4	M200	W/12	: To M71
B3	M40	W/12	: Key slot	E3	M203	GR/2	: Front console antenna
D2	M44	W/20	: Audio unit	E4	M204	GR/6	: To M99
E2	M45	W/32	: Audio unit	D4	M205	W/3	: To M76
E1	M46	W/12	: Audio unit	F3	M206	B/2	: Front power socket lamp
D3	M50	W/2	: To M150	F3	M207	B/1	: Front power socket lamp (for cigarette lighter)
B1	M51	BR/2	: Front tweeter LH	E4	M208	B/3	: Front power socket
G1	M52	BR/2	: Front tweeter RH	D3	M209	B/3	: Front console power socket
C3	M53	W/8	: Steering angle sensor	D3	M210	W/12	: To M93
D1	M54	W/4	: Hazard switch	E4	M211	G/4	: USB interface
E5	M55	B/4	: Yaw rate/side/decel G sensor	D3	M212	W/8	: Aux jack

HARNESS

< DTC/CIRCUIT DIAGNOSIS >

[COUPE]

ENGINE ROOM HARNESS

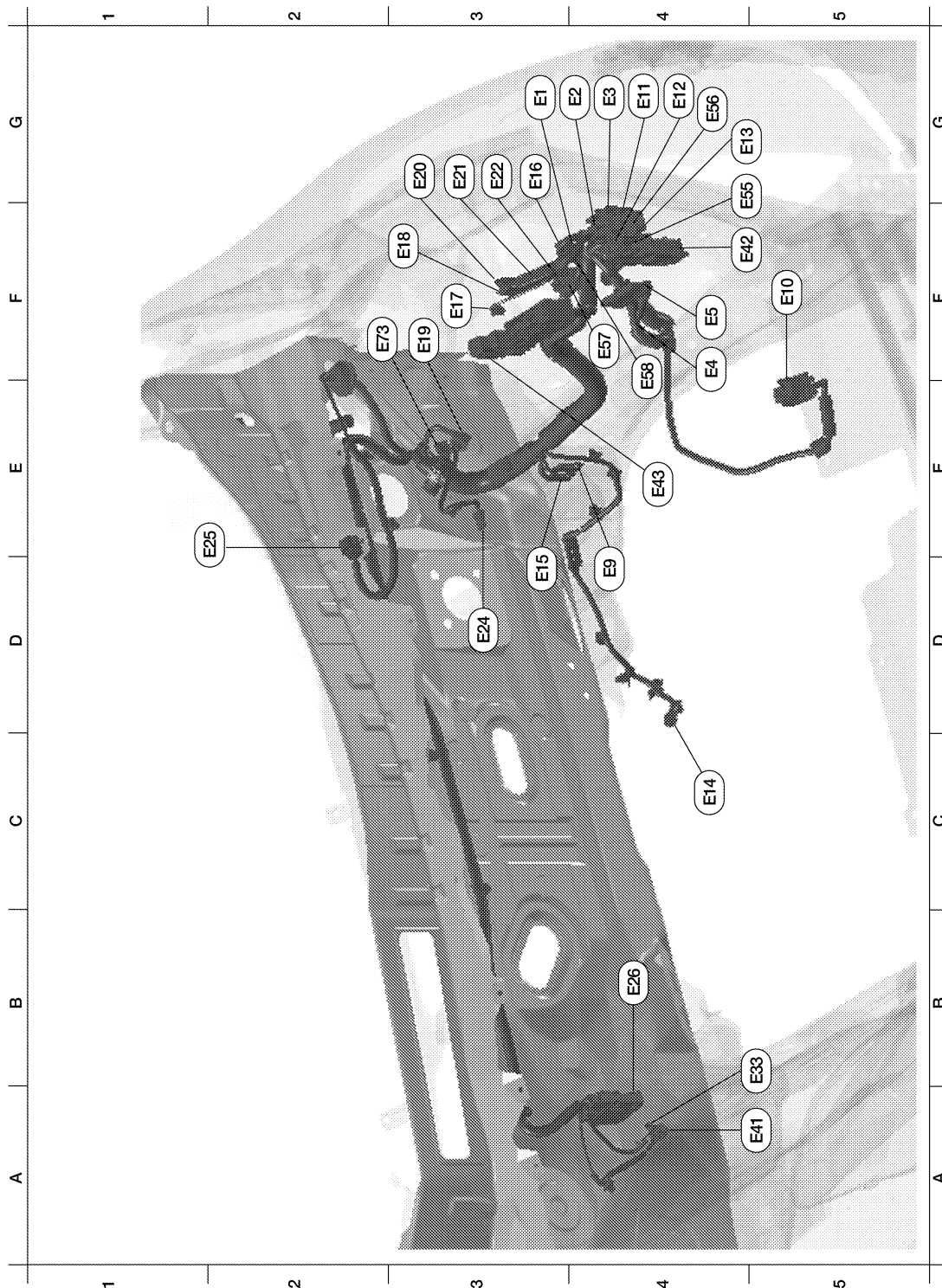

ABMIA3270GB

G3	E1	W/6	: Joint connector-E01	G3	E20	W/6	: Joint connector-E02
G3	E2	W/8	: To E202	G3	E21	W/4	: Joint connector-E03
G4	E3	W/16	: To F1	G3	E22	W/4	: Joint connector-E04
F4	E4	BR/2	: Fusible link box (battery)	D3	E24	GR/2	: Brake fluid level switch
F4	E5	GR/2	: Fusible link box (battery)	D3	E24	GR/2	: Brake fluid level switch

HARNESSES

< DTC/CIRCUIT DIAGNOSIS >

[COUPE]

E3	E9	—	: Body ground	B4	E26	B/26	: ABS actuator and electric unit (control unit)
F5	E10	B/32	: ECM	B5	E33	—	: Body ground
G4	E11	W/10	: To F2	A5	E41	GR/2	: Front wheel sensor RH
G4	E12	W/6	: To E203	F5	E42	BR/6	: Cooling fan relay-2
G4	E13	B/3	: To E205	B3	E43	BR/6	: Cooling fan relay-3
C4	E14	B/2	: Power steering solenoid valve	G4	E55	W4	:Joint connector-E07
D3	E15	—	: Body ground	G4	E56	W/4	:Joint connector-E14
G5	E16	B/2	: IPDM E/R (Intelligent power distribution module engine room)	F4	E57	L/4	:Stop lamp relay-1
F3	E17	W/8	: IPDM E/R (Intelligent power distribution module engine room)	F4	E58	L/4	:Stop lamp relay-2
F3	E18	W/36	: IPDM E/R (Intelligent power distribution module engine room)	E3	E73	BR/3	: Intelligent Key warning buzzer
F3	E19	GR/2	: Front wheel sensor LH				

HARNESS

[COUPE]

< DTC/CIRCUIT DIAGNOSIS >

ENGINE ROOM HARNESS (PASSENGER COMPARTMENT)

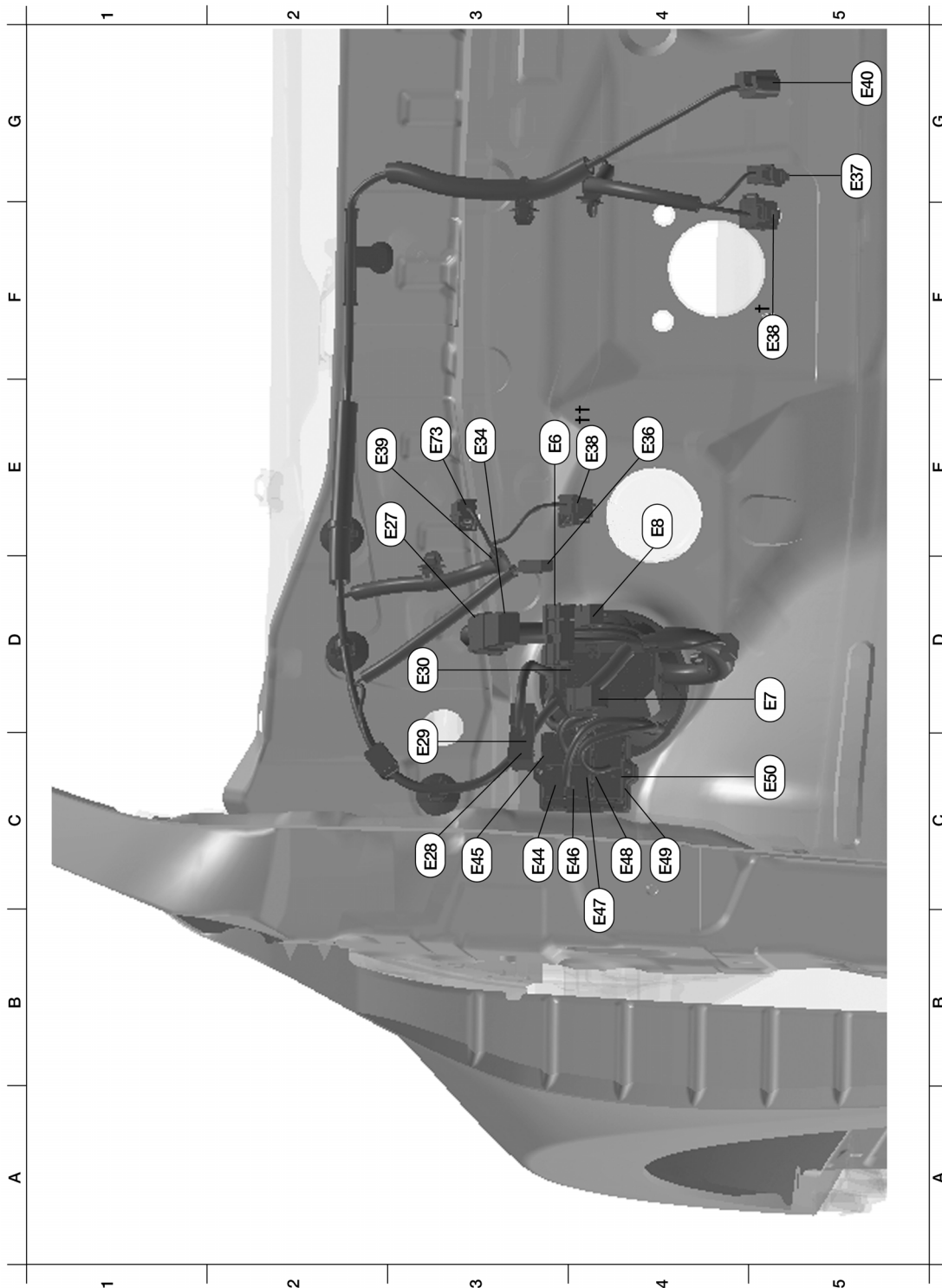

ABMIA1993GB

E3	E6	W/16	: Fuse block (J/B)	E4	E38††	B/2	: Stop lamp switch (with M/T)
D5	E7	W/1	: Fuse block (J/B)	E2	E39	BR/2	: ASCD clutch switch
E4	E8	B/2	: Fuse block (J/B)	G5	E40	B/6	: Accelerator pedal position (APP) sensor
E3	E27	W/4	: Joint connector-E06	C3	E44	BR/12	: Junction block
C3	E28	W/4	: Joint connector-E05	C3	E45	W/12	: Junction block

HARNESS

< DTC/CIRCUIT DIAGNOSIS >

[COUPE]

C3	E29	W/16	: To B10	C4	E46	W/16	: Junction block
D3	E30	SMJ	: To M1	C4	E47	W/6	: Junction block
E3	E34	L/4	: Back-up lamp relay	C4	E48	W/4	: Junction block
E4	E36	BR/2	: Clutch interlock switch	C4	E49	BR/4	: Junction block
G5	E37	BR/2	: ASCD brake switch	C5	E50	W/2	: Junction block
F5	E38†	W/4	: Stop lamp switch (with CVT)				

HARNESS

< DTC/CIRCUIT DIAGNOSIS >

[COUPE]

FRONT END MODULE HARNESS

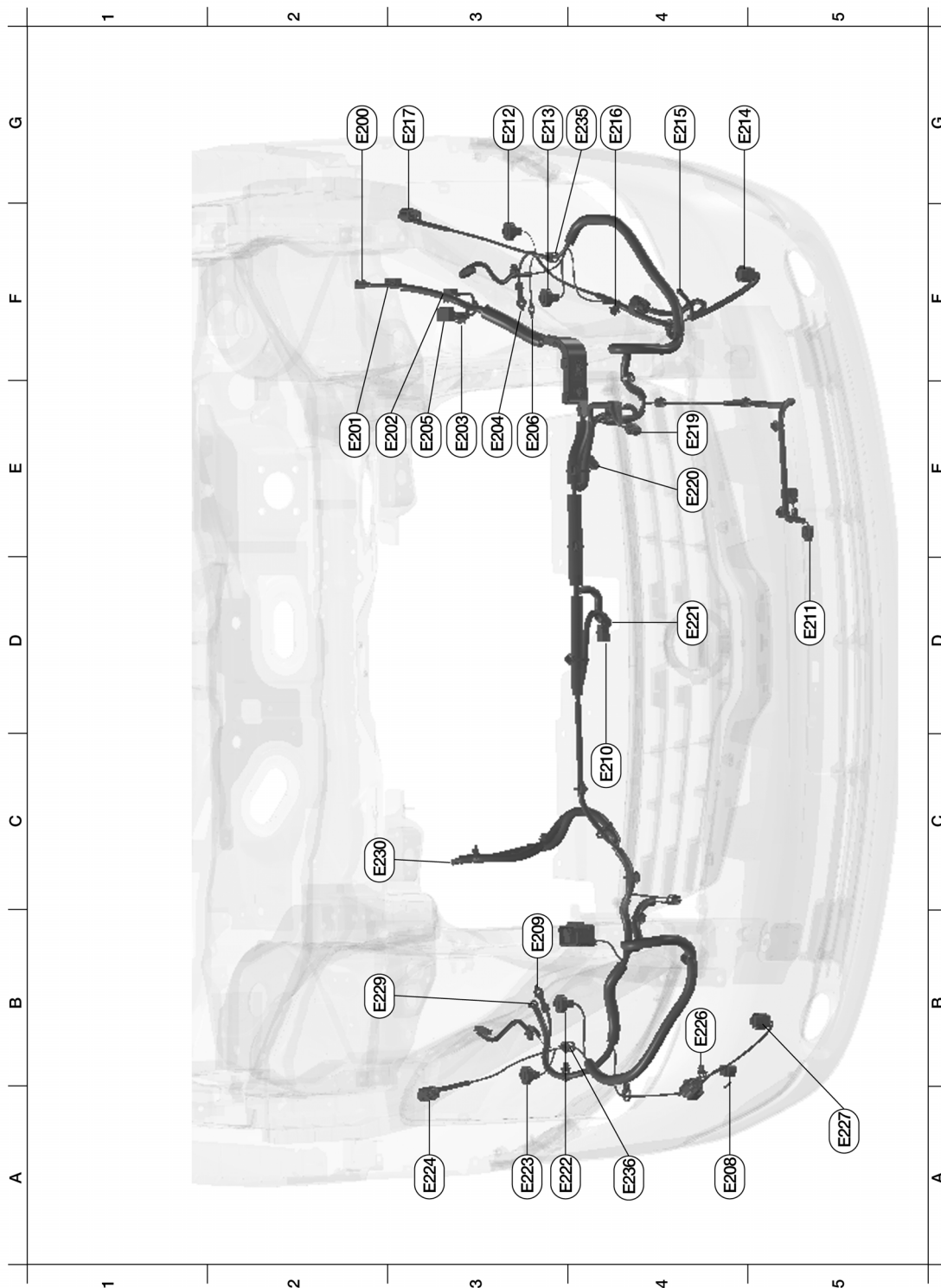

ABMIA1994GB

G2	E200	W/8	: IPDM E/R (Intelligent power distribution module engine room)	G4	E216	B/1	: Horn (high)
E2	E201	W/16	: IPDM E/R (Intelligent power distribution module engine room)	G3	E217	GR/3	: Front combination lamp LH
E3	E202	W/8	: To E2	E4	E219	B/3	: Refrigerant pressure sensor
E3	E203	W/6	: To E12	E4	E220	GR/4	: Cooling fan motor-1

A
B
C
D
E
F
G
H
I
J
K
L
M
N
O
P

PG

HARNESSES

< DTC/CIRCUIT DIAGNOSIS >

[COUPE]

E3	E204	—	: Body ground	D4	E221	GR/4	: Cooling fan motor-2
E3	E205	B/3	: To E13	A3	E222	B/2	: Front combination lamp RH
E3	E206	—	: Body ground	A3	E223	B/2	: Front combination lamp RH (halogen)
A4	E208	W/2	: Washer fluid level switch	A3	E223	GR/2	: Front combination lamp RH (xenon)
B3	E209	—	: Body ground	A3	E224	GR/3	: Front combination lamp RH
C4	E210	Y/2	: Crash zone sensor	B4	E226	B/2	: Front washer motor
D5	E211	B/2	: Ambient sensor	A5	E227	B/2	: Front fog lamp RH
G3	E212	B/2	: Front combination lamp LH (halogen)	B3	E229	—	: Body ground
G3	E212	GR/2	: Front combination lamp LH (xenon)	C2	E230	—	: Generator
G3	E213	B/2	: Front combination lamp LH	G4	E235	GR/2	: Front combination lamp LH
G4	E214	B/2	: Front fog lamp LH	A4	E236	GR/2	: Front combination lamp RH
G4	E215	B/1	: Horn (low)				

HARNESS

< DTC/CIRCUIT DIAGNOSIS >

[COUPE]

ENGINE CONTROL HARNESS (VQ35DE)

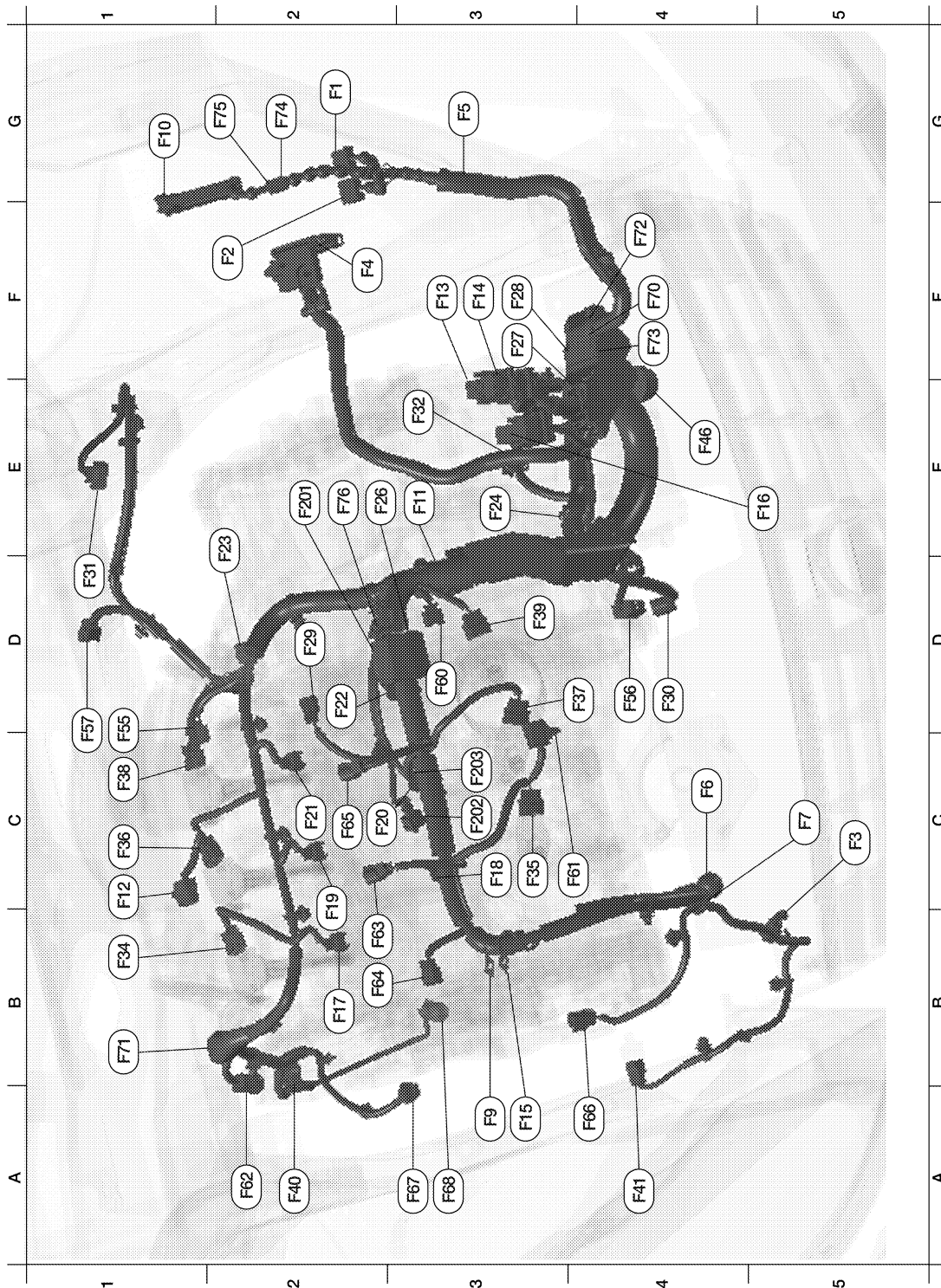

ABMIA0743GB

G2	F1	W/16	: To E3	C3	F35	GR/3	: Ignition coil No. 2 (with power transistor)
F1	F2	W/10	: To E11	C1	F36	GR/3	: Ignition coil No. 3 (with power transistor)
C5	F3	B/2	: A/C Compressor	D3	F37	GR/3	: Ignition coil No. 4 (with power transistor)
F2	F4	—	: Fusible link box (battery)	C1	F38	GR/3	: Ignition coil No. 5 (with power transistor)
G3	F5	B/3	: Battery current sensor	D3	F39	GR/3	: Ignition coil No. 6 (with power transistor)

HARNESSES

< DTC/CIRCUIT DIAGNOSIS >

[COUPE]

C4	F6	—	: Generator	A2	F40	B/3	: Power steering pressure sensor
C5	F7	B/3	: Generator	A4	F41	GR/1	: Oil pressure switch
A3	F9	—	: Engine ground	E4	F46	B/22	: CVT unit
G1	F10	W/36	: IPDM E/R (Intelligent power distribution module engine room)	D1	F55	B/3	: Camshaft position sensor (PHASE) (bank 1)
E3	F11	GR/2	: Engine coolant temperature sensor	D4	F56	B/4	: Heated oxygen sensor 2 (bank 2)
C1	F12	GR/4	: Air fuel ratio (A/F) sensor 1 (bank 1)	D1	F57	B/6	: Electric throttle control actuator
F3	F13	BR/48	: ECM	D3	F60	B/3	: Camshaft position sensor (PHASE) (bank 2)
F3	F14	GR/32	: ECM	C3	F61	GR/4	: Air fuel ratio (A/F) sensor 1 (bank 2)
A3	F15	—	: Engine ground	A2	F62	B/4	: Heated oxygen sensor 2 (bank 1)
E4	F16	B/48	: TCM (Transmission control module)	B2	F63	B/2	: VIAS control solenoid valve 1
B2	F17	GR/2	: Fuel injector No. 1	B2	F64	BR/2	: Electronic controlled engine mount control solenoid valve
C3	F18	GR/2	: Fuel injector No. 2	C2	F65	B/2	: VIAS control solenoid valve 2
B2	F19	GR/2	: Fuel injector No. 3	A3	F66	G/2	: Intake valve timing control solenoid valve (bank 2)
C2	F20	GR/2	: Fuel injector No. 4	A2	F67	G/2	: Intake valve timing control solenoid valve (bank 1)
C2	F21	GR/2	: Fuel injector No. 5	A3	F68	GR/2	: Engine oil temperature sensor
D2	F22	GR/2	: Fuel injector No. 6	F4	F70	B/10	: Joint connector-F01
E1	F23	B/3	: Secondary speed sensor	B1	F71	G/6	: Joint connector-F03
E3	F24	B/2	: Back-up lamp switch	F4	F72	B/10	: Joint connector-F04
E2	F26	W/2	: Condenser-2	F4	F73	B/10	: Joint connector-F05
F3	F27	—	: Starter motor	G2	F74	W/4	: Joint connector-F08
F3	F28	GR/1	: Starter motor	G1	F75	W/4	: Joint connector-F07
D2	F29	L/2	: EVAP canister purge volume control solenoid valve	E2	F76	L/4	: To F201
D4	F30	B/3	: Crankshaft position sensor (POS)	Knock sensor sub-harness			
D1	F31	B/6	: Mass air flow sensor	E2	F201	L/4	: To F76
E3	F32	B/2	: Park/neutral position (PNP) switch	C3	F202	GR/2	: Knock sensor (bank 1)
B1	F34	GR/3	: Ignition coil No. 1 (with power transistor)	C3	F203	GR/2	: Knock sensor (bank 2)

HARNESS

< DTC/CIRCUIT DIAGNOSIS >

[COUPE]

ENGINE CONTROL HARNESS (QR25DE)

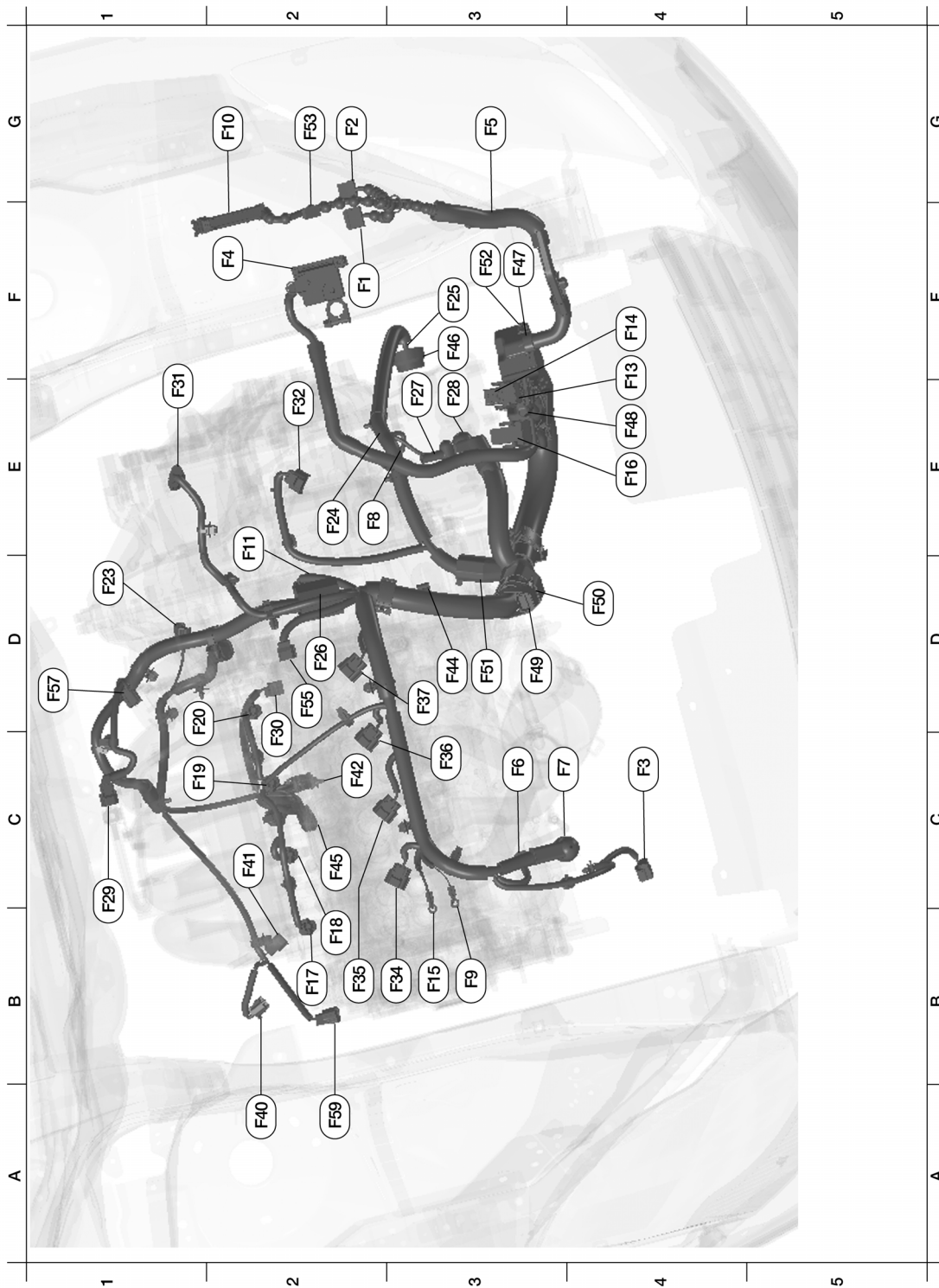

ABMIA1995GB

F2	F1	W/16	: To E3	C1	F29	L/2	: EVAP canister purge volume control solenoid valve
G2	F2	W/10	: To E11	C2	F30	B/3	: Crankshaft position sensor (POS)
C4	F3	B/12	: A/C Compressor	E1	F31	B/6	: Mass air flow sensor
F2	F4	—	: Fusible link box (battery)	E2	F32	B/2	: Park/neutral position (PNP) switch
G3	F5	B/3	: Battery current sensor	B3	F34	GR/3	: Ignition coil No. 1 (with power transistor)

HARNESS

< DTC/CIRCUIT DIAGNOSIS >

[COUPE]

C3	F6	—	: Generator	B2	F35	GR/3	: Ignition coil No. 2 (with power transistor)
C3	F7	B/3	: Generator	C3	F36	GR/3	: Ignition coil No. 3 (with power transistor)
E2	F8	B/3	: Primary speed sensor	D3	F37	GR/3	: Ignition coil No. 4 (with power transistor)
B3	F9	—	: Engine ground	A2	F40	B/3	: Power steering pressure sensor
G2	F10	W/36	: IPDM E/R (Intelligent power distribution module engine room)	C2	F41	GR/1	: Oil pressure switch
E2	F11	GR/2	: Engine coolant temperature sensor	C2	F42	B/4	: Heated oxygen sensor 2
E4	F13	BR/48	: ECM	D3	F44	GR/4	: Air fuel ratio (A/F) sensor 1
F4	F14	GR/32	: ECM	C2	F45	GR/2	: Knock sensor
B3	F15	—	: Engine ground	F3	F46	B/22	: CVT unit
E4	F16	B/48	: TCM (Transmission control module)	F3	F47	B/6	: Joint connector-F01
B2	F17	GR/2	: Fuel injector No. 1	E4	F48	B/6	: Joint connector-F02
B2	F18	GR/2	: Fuel injector No. 2	D3	F49	B/10	: Joint connector-F03
C1	F19	GR/2	: Fuel injector No. 3	D4	F50	B/10	: Joint connector-F04
D1	F20	GR/2	: Fuel injector No. 4	D3	F51	B/6	: Joint connector-F05
D1	F23	B/3	: Secondary speed sensor	F3	F52	B/10	: Joint connector-F06
E2	F24	B/2	: Back-up lamp switch	G2	F53	W/4	: Joint connector-F07
F3	F25	B/10	: Transmission range switch	D2	F55	B/3	: Camshaft position sensor (PHASE)
D2	F26	W/2	: Condenser-2	D1	F57	B/6	: Electric throttle control actuator
E3	F27	—	: Starter motor	A2	F59	G/2	: Intake valve timing control solenoid valve
E3	F28	—	: Starter motor				

HARNESS

< DTC/CIRCUIT DIAGNOSIS >

[COUPE]

BODY HARNESS

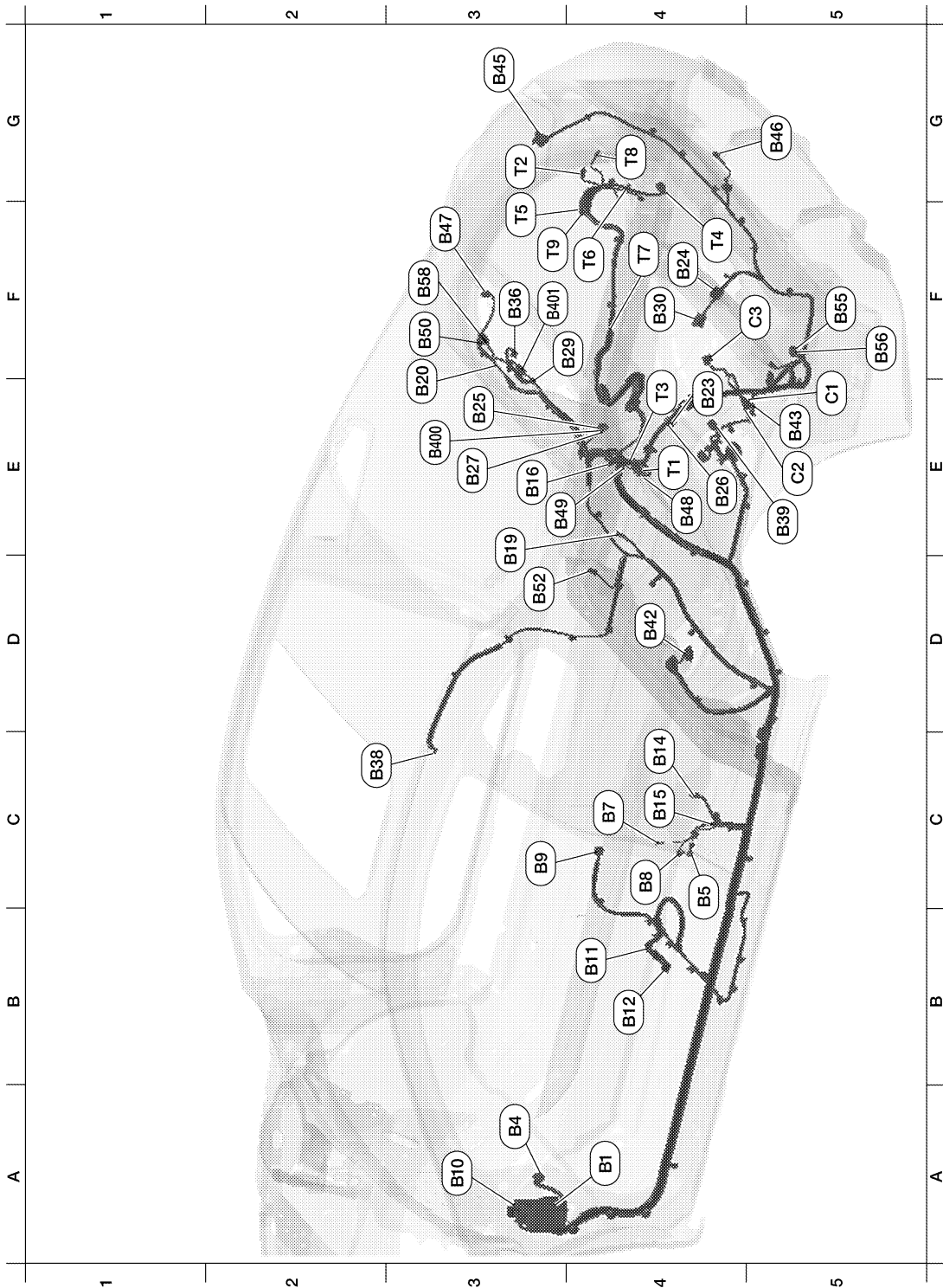

ABMIA3271GB

A4	B1	SMJ	: To M6	G5	B46	GR/2	: Rear bumper antenna
A3	B4	BR/12	: Fuse block (J/B)	F3	B47	W/2	: Rear subwoofer RH
C4	B5	—	: Body ground	E4	B48	W/16	: To T1
C4	B7	—	: Body ground	E3	B49	W/2	: To T3
C4	B8	W/3	: Door switch LH	E3	B50	W/6	: To B138

HARNESSES

[COUPE]

< DTC/CIRCUIT DIAGNOSIS >

C3	B9	Y/12	: Air bag diagnosis sensor unit	D3	B52	W/1	: Condenser
A3	B10	W/16	: To E29	F5	B55	W/32	: Bluetooth control unit
B4	B11	Y/2	: Front LH side air bag module	F5	B56	W/8	: Bluetooth control unit
B4	B12	W/8	: To B201	F3	B58	—	: Body ground
C4	B14	Y/2	: Front LH seat belt pre-tensioner	High-mounted stop lamp sub-harness			
C4	B15	Y/2	: LH side air bag (satellite) sensor	E3	B400	W/2	: To B27
E3	B16	BR/2	: Rear tweeter LH	F3	B401	W/2	: High-mounted stop lamp
E4	B19	—	: Body ground	Tail lamp sub-harness			
E3	B20	W/4	: Joint connector-B05	E4	T1	W/16	: To B48
E3	B23	W/4	: Joint connector-B06	G3	T2	BR/2	: Trunk opener request switch
F4	B24	W/4	: Joint connector-B07	E4	T3	W/2	: To B49
E3	B25	W/2	: Rear subwoofer LH	F4	T4	W/4	: Trunk lamp switch and trunk release solenoid
E4	B26	W/4	: Joint connector-B03	F3	T5	W/4	: Joint connector-T01
E3	B27	W/2	: To B400	F4	T6	BR/2	: License plate lamp LH
F3	B29	GR/2	: Rear parcel shelf antenna	F4	T7	W/4	: Rear view camera
F4	B30	W/6	: Rear combination lamp LH	G5	T8	BR/2	: License plate lamp RH
F3	B36	W/2	: Trunk room lamp	F3	T9	W/4	: Joint connector-T02
C2	B38	Y/2	: LH side curtain air bag module	Chassis harness			
E5	B39	B/2	: EVAP canister vent control valve	E5	C1	GR/4	: To B43
D4	B42	GR/5	: Fuel level sensor unit and fuel pump	E5	C2	B/2	: Rear wheel sensor LH
E5	B43	GR/4	: To C1	F5	C3	GR/2	: Rear wheel sensor RH
G3	B45	W/6	: Rear combination lamp RH				

HARNESS

< DTC/CIRCUIT DIAGNOSIS >

[COUPE]

BODY NO. 2 HARNESS

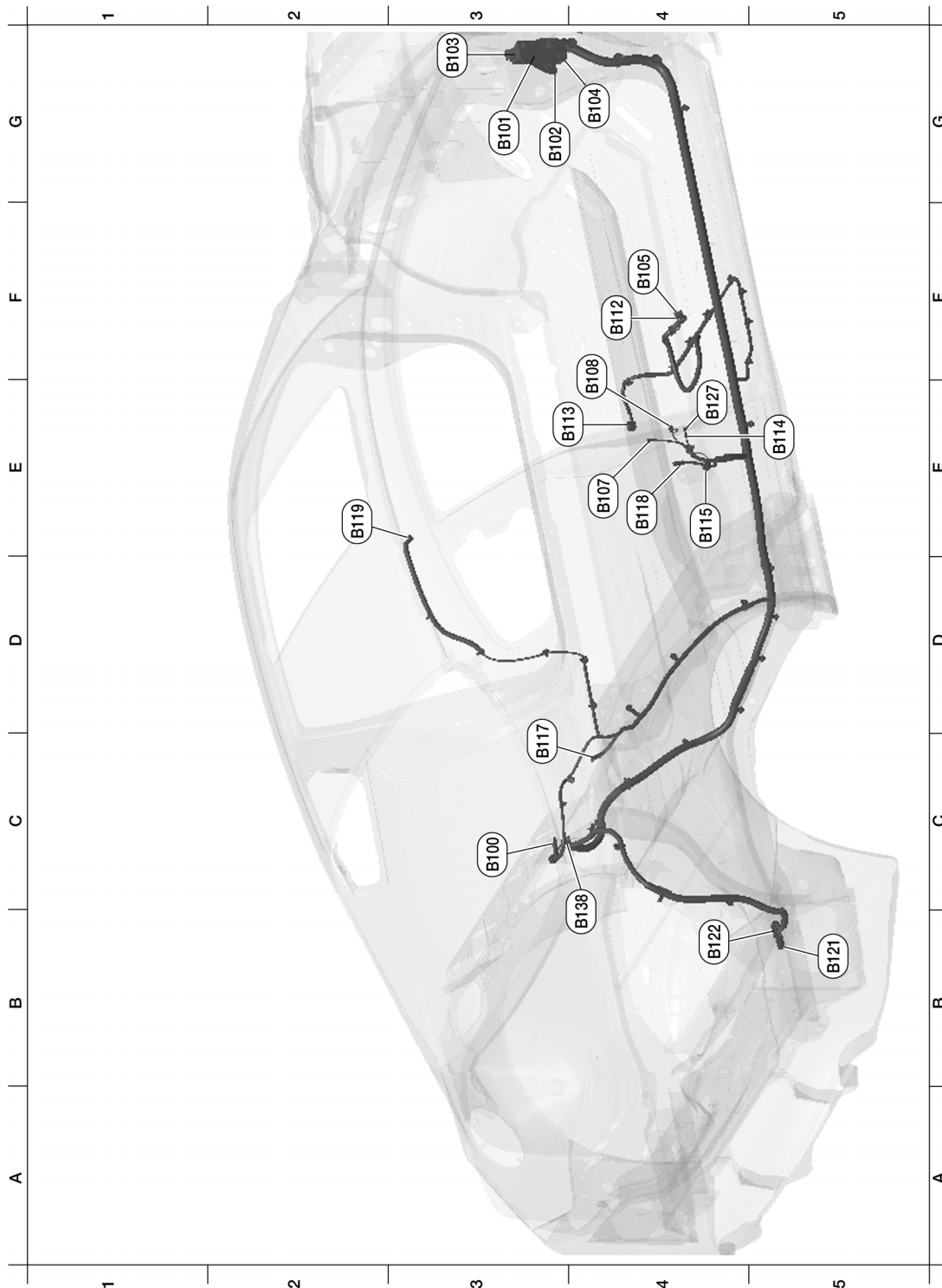

ABMIA1997GB

C3	B100	BR/2	: Rear tweeter RH	E5	B114	—	: Body ground
F3	B101	W/32	: To M2	F4	B115	Y/2	: Front RH seat belt pre-tensioner
G3	B102	W/24	: To M8	E4	B117	—	: Body ground
G3	B103	BR/16	: To M9	E4	B118	Y/2	: RH side air bag (satellite) sensor
G2	B104	BR/12	: To M10	D3	B119	Y/2	: RH side curtain air bag module

A
B
C
D
E
F
G
H
I
J
K
L
PG
N
O
P

HARNESS

< DTC/CIRCUIT DIAGNOSIS >

[COUPE]

G3	B105	W/8	: To B301	C3	B121	BR/23	: BOSE speaker amp.
E3	B107	—	: Body ground	B4	B122	BR/14	: BOSE speaker amp.
E3	B108	W/3	: Door switch RH	B4	B127	—	: Body ground
G4	B112	Y/2	: Front RH side air bag module	C3	B138	W/6	: To B50
A3	B113	Y/12	: Air bag diagnosis sensor unit				

ROOM LAMP HARNESS

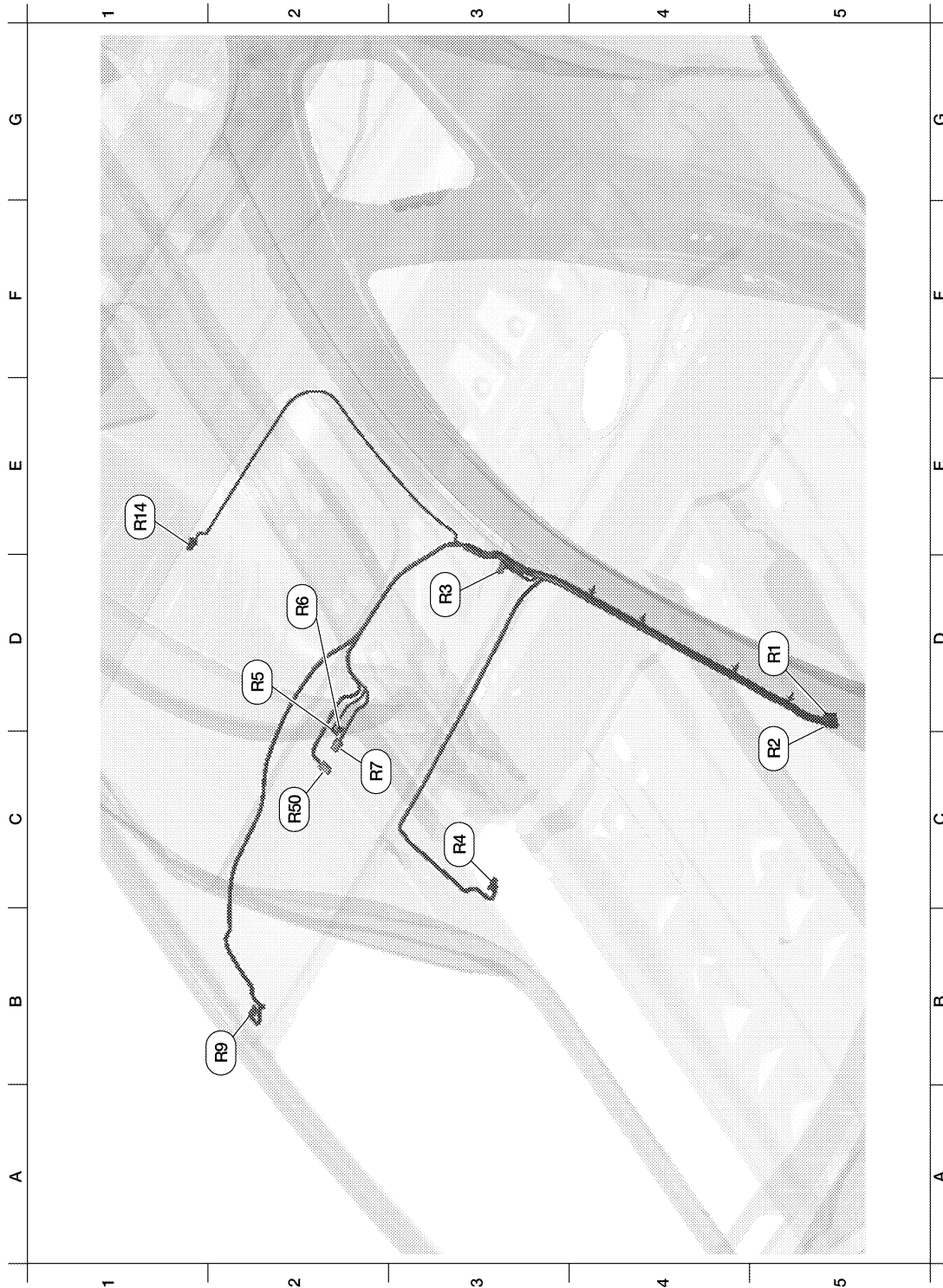

ABMIA0746GB

HARNESS

< DTC/CIRCUIT DIAGNOSIS >

[COUPE]

D5	R1	W/16	: To M7	D2	R6	W/3	: Sunroof switch
C5	R2	W/4	: To M13	C2	R7	W/4	: Microphone
D3	R3	W/2	: Vanity mirror lamp LH	B2	R9	W/2	: Vanity mirror lamp RH
C3	R4	B/7	: Auto anti-dazzling inside mirror	E1	R14	—	: Interior room lamp
C2	R5	GR/10	: Sunroof motor assembly	C2	R50	GR/6	: Front room/map lamp assembly

DOOR LH HARNESS

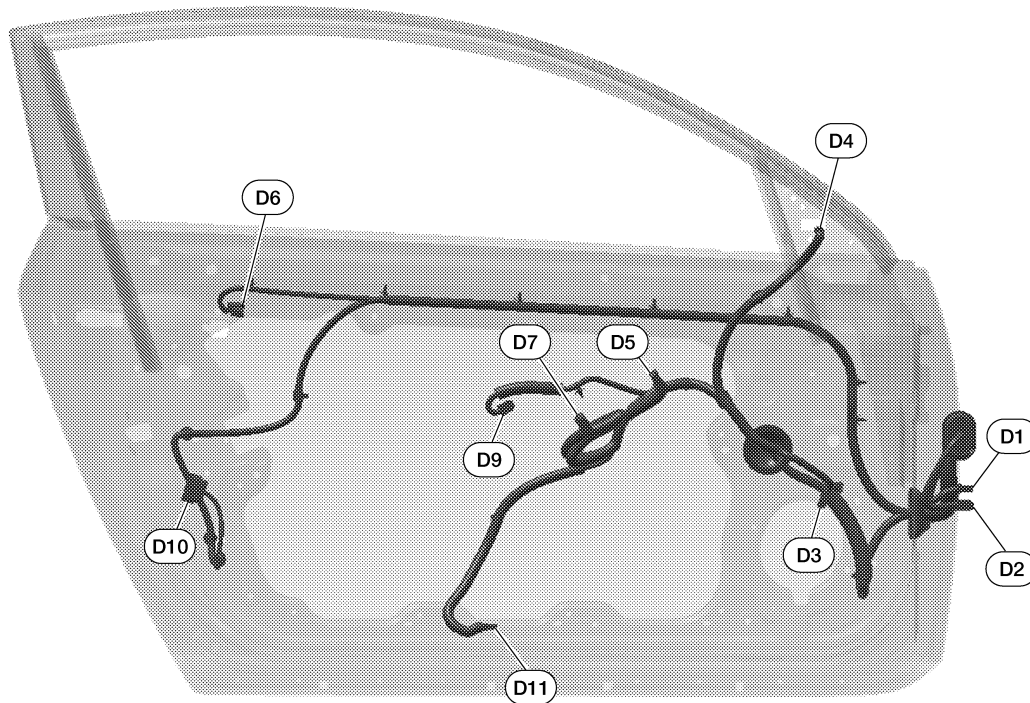

ALMIA0399GB

D1	W/16	: To M11	D6	B/4	: Outside handle LH
D2	W/16	: To M12	D7	W/16	: Main power window and door lock/unlock switch
D3	W/2	: Door speaker LH	D9	W/6	: Power window motor LH
D4	W/8	: Door mirror LH	D10	GR/6	: Door lock assembly LH
D5	W/16	: Door mirror remote control switch	D11	W/2	: Step lamp LH

HARNESS

< DTC/CIRCUIT DIAGNOSIS >

[COUPE]

DOOR RH HARNESS

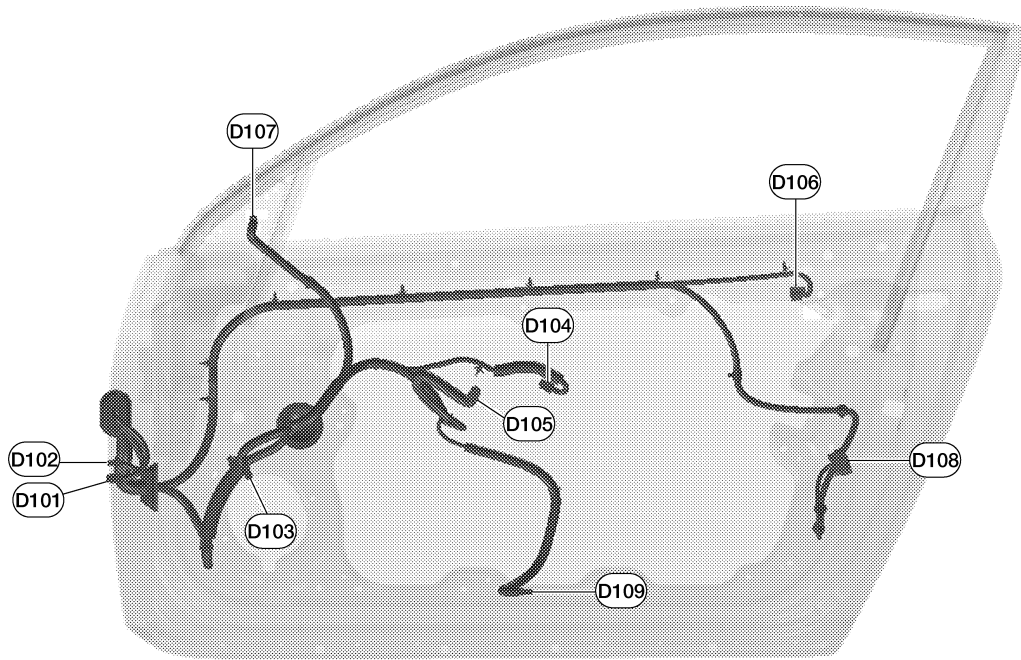

ALMIA0400GB

D101	W/10	: To M14	D106	B/4	: Outside handle RH
D102	W/12	: To M15	D107	W/8	: Door mirror RH
D103	W/2	: Door speaker RH	D108	GR/6	: Door lock actuator RH
D104	W/6	: Power window motor RH	D109	W/2	: Step lamp RH
D105	W/16	: Power window and door lock/unlock switch RH			

ELECTRICAL UNITS LOCATION

< DTC/CIRCUIT DIAGNOSIS >

[COUPE]

ELECTRICAL UNITS LOCATION

Electrical Units Location

INFOID:000000007419554

ENGINE COMPARTMENT

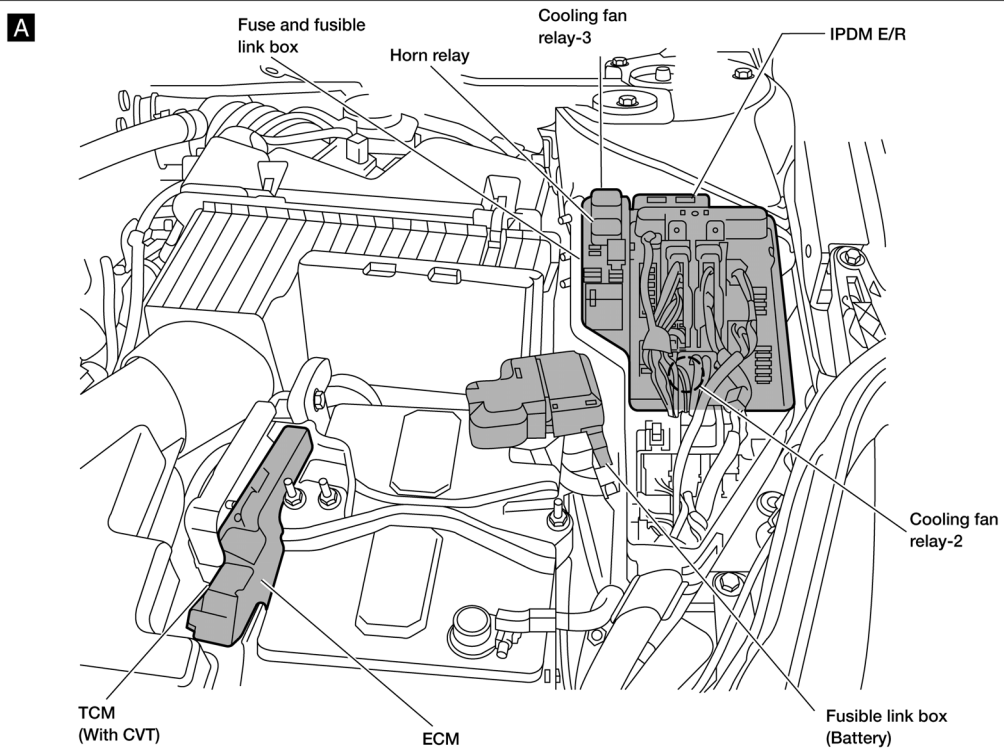
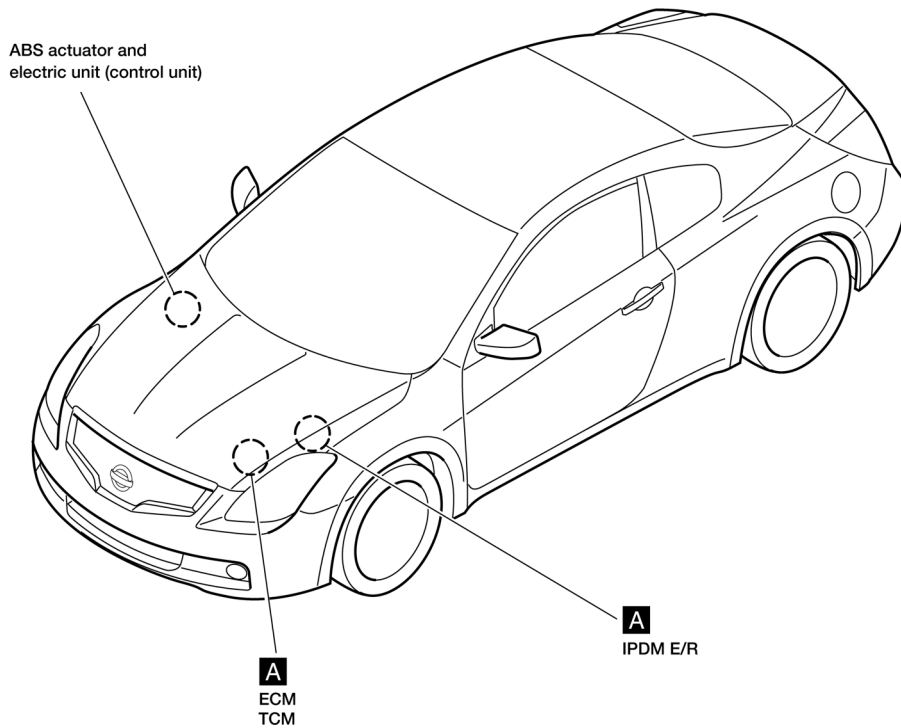

ABMIA1998GB

ELECTRICAL UNITS LOCATION

< DTC/CIRCUIT DIAGNOSIS >

[COUPE]

PASSENGER COMPARTMENT

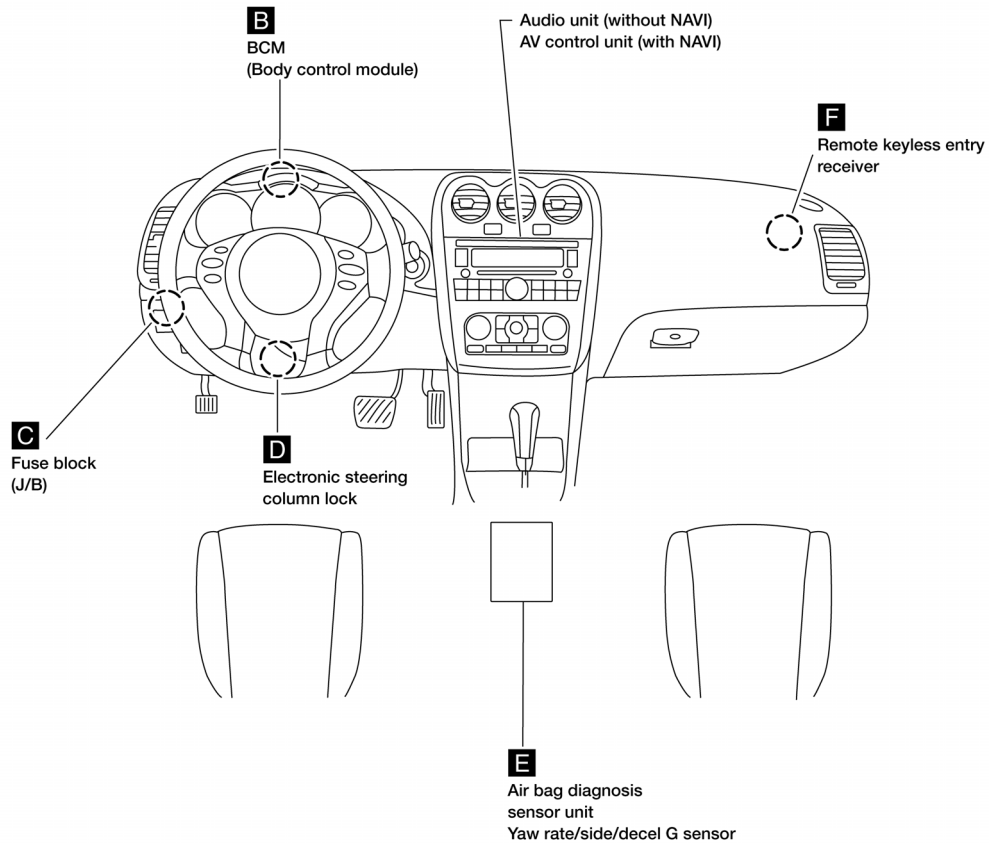

AAMIA0640GB

ELECTRICAL UNITS LOCATION

< DTC/CIRCUIT DIAGNOSIS >

[COUPE]

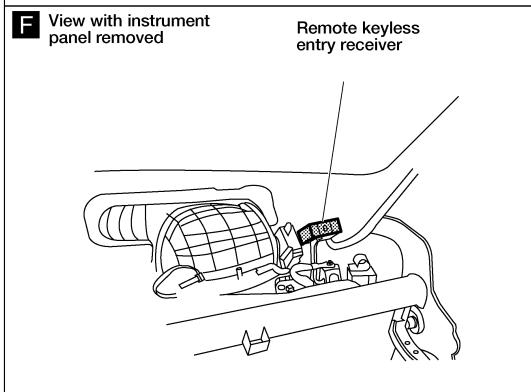
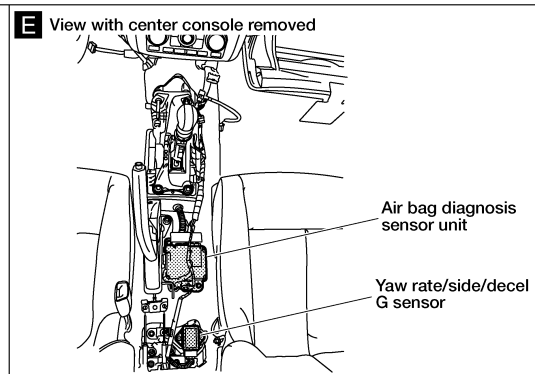
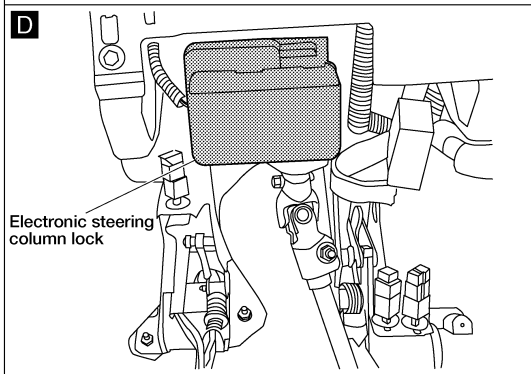
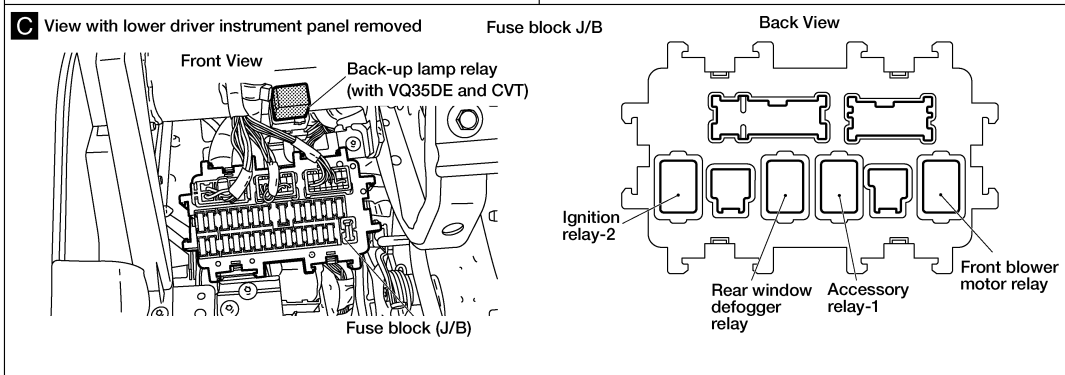
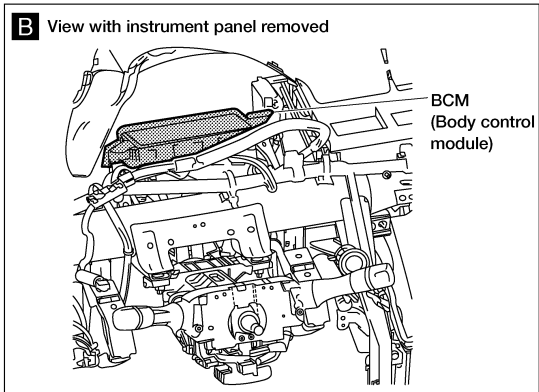

A
B
C
D
E
F
G
H
I
J
K
L
PG
N
O
P

ABMIA4558GB

ELECTRICAL UNITS LOCATION

< DTC/CIRCUIT DIAGNOSIS >

[COUPE]

LUGGAGE COMPARTMENT

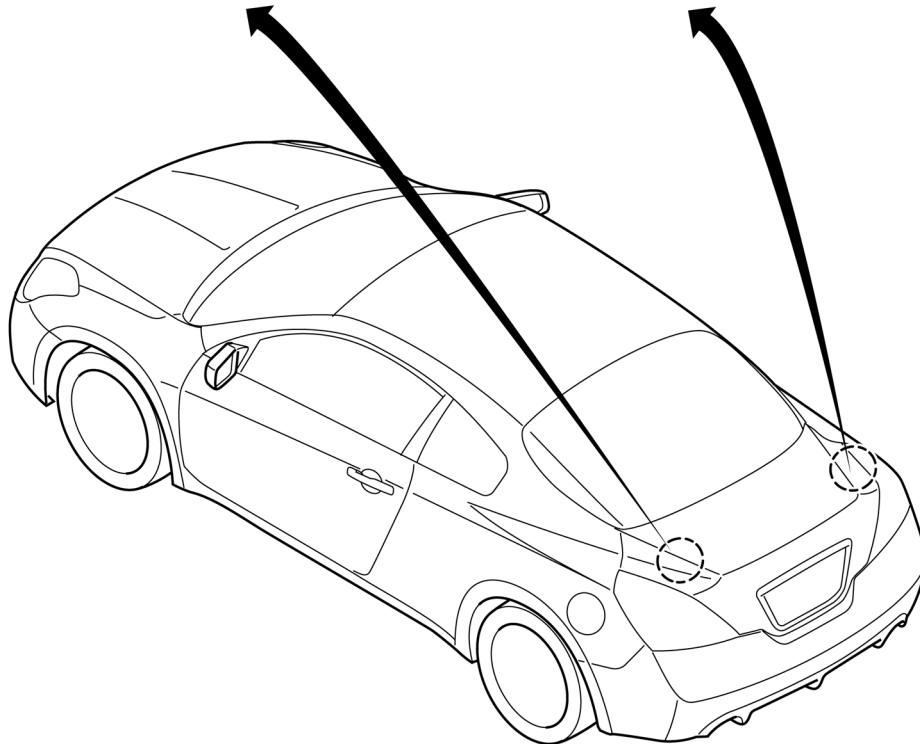
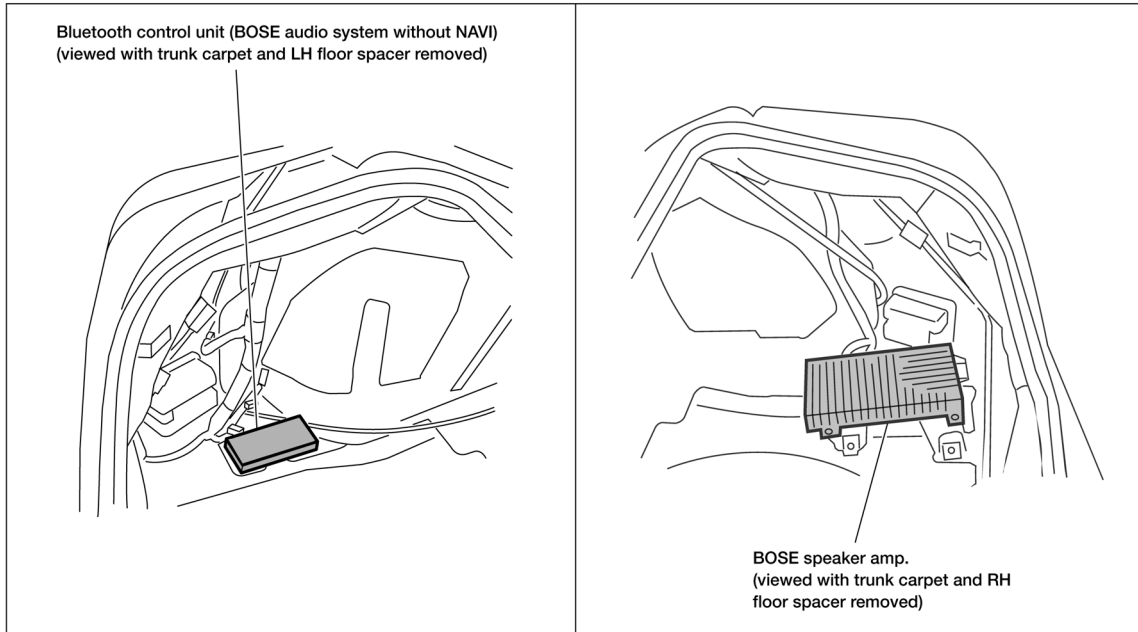

AAMIA0641GB

HARNESS CONNECTOR

Description

INFOID:000000007419555

HARNESS CONNECTOR (TAB-LOCKING TYPE)

- The tab-locking type connectors help prevent accidental looseness or disconnection.
- The tab-locking type connectors are disconnected by pushing or lifting the locking tab(s). Refer to the illustration below.

Refer to the next page for description of the slide-locking type connector.

CAUTION:

Do not pull the harness or wires when disconnecting the connector.

[Example]

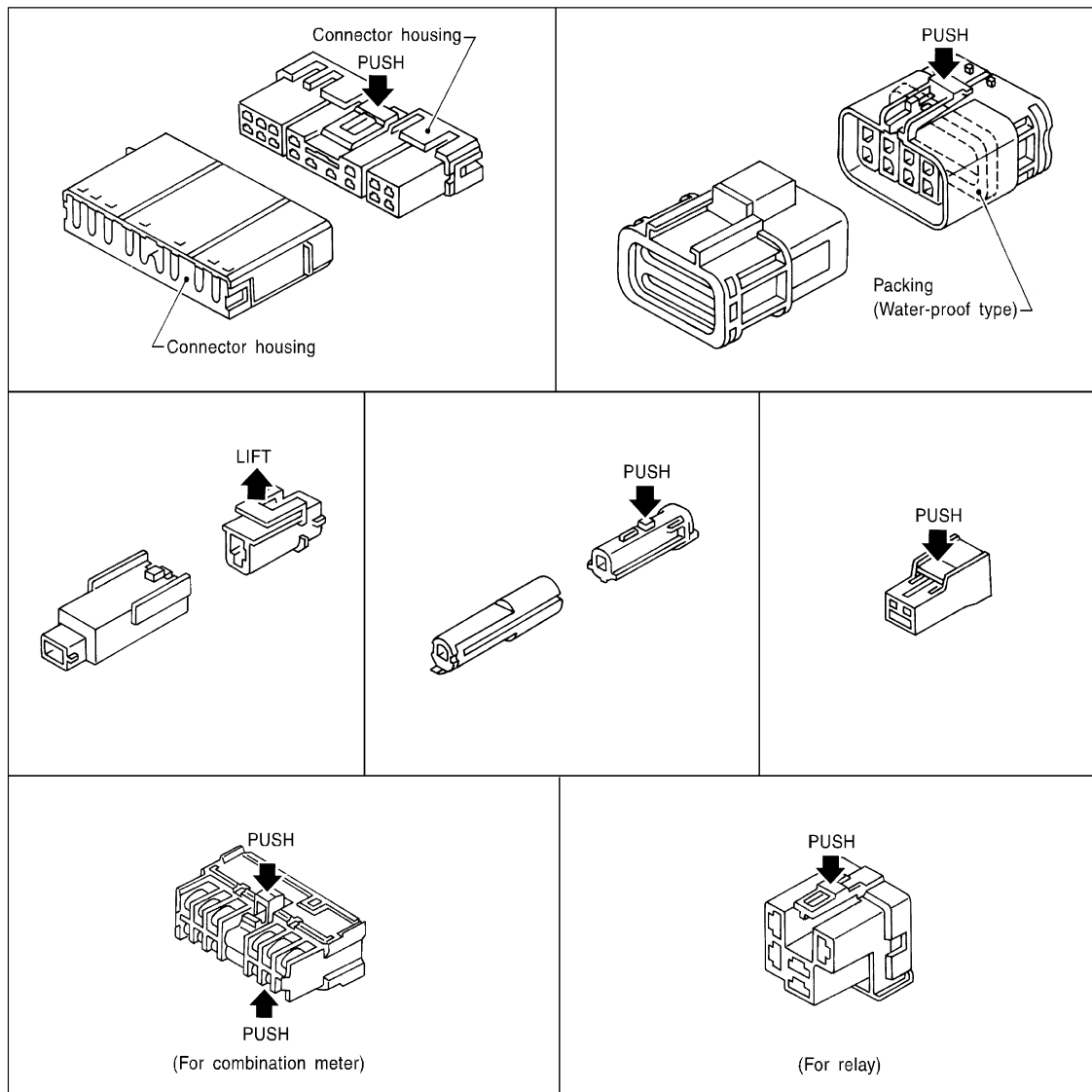

SEL769DA

HARNESS CONNECTOR (SLIDE-LOCKING TYPE)

- A new style slide-locking type connector is used on certain systems and components, especially those related to OBD.
- The slide-locking type connectors help prevent incomplete locking and accidental looseness or disconnection.
- The slide-locking type connectors are disconnected by pushing or pulling the slider. Refer to the illustration below.

A
B
C
D
E
F
G
H
I
J
K
L
PG
N
O
P

HARNESS CONNECTOR

< DTC/CIRCUIT DIAGNOSIS >

[COUPE]

CAUTION:

- Do not pull the harness or wires when disconnecting the connector.
- Be careful not to damage the connector support bracket when disconnecting the connector.

[Example]

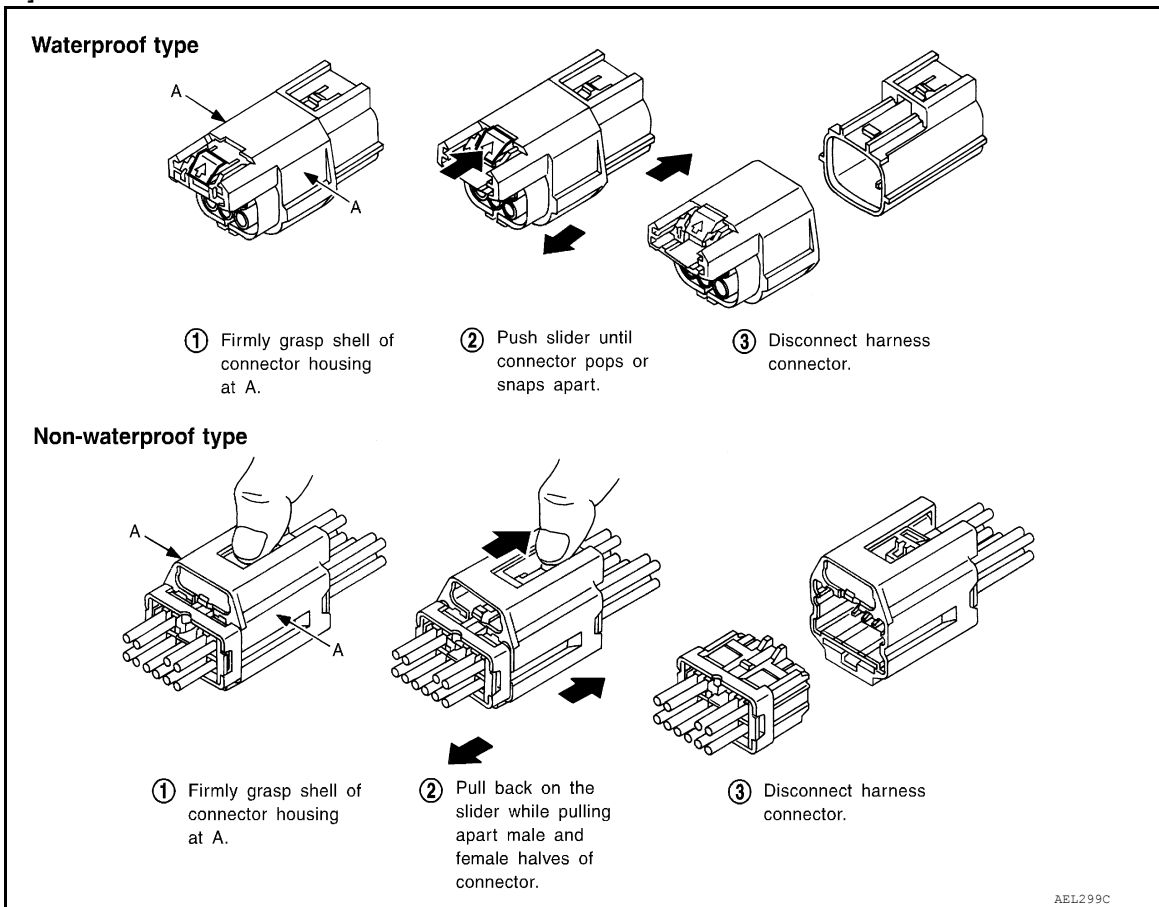

HARNESS CONNECTOR (LEVER LOCKING TYPE)

- Lever locking type harness connectors are used on certain control units and control modules such as ECM, ABS actuator and electric unit (control unit), etc.
- Lever locking type harness connectors are also used on super multiple junction (SMJ) connectors.
- Always confirm the lever is fully locked in place by moving the lever as far as it will go to ensure full connection.

CAUTION:

HARNES CONNECTOR

< DTC/CIRCUIT DIAGNOSIS >

[COUPE]

Always confirm the lever is fully released (loosened) before attempting to disconnect or connect these connectors to avoid damage to the connector housing or terminals.

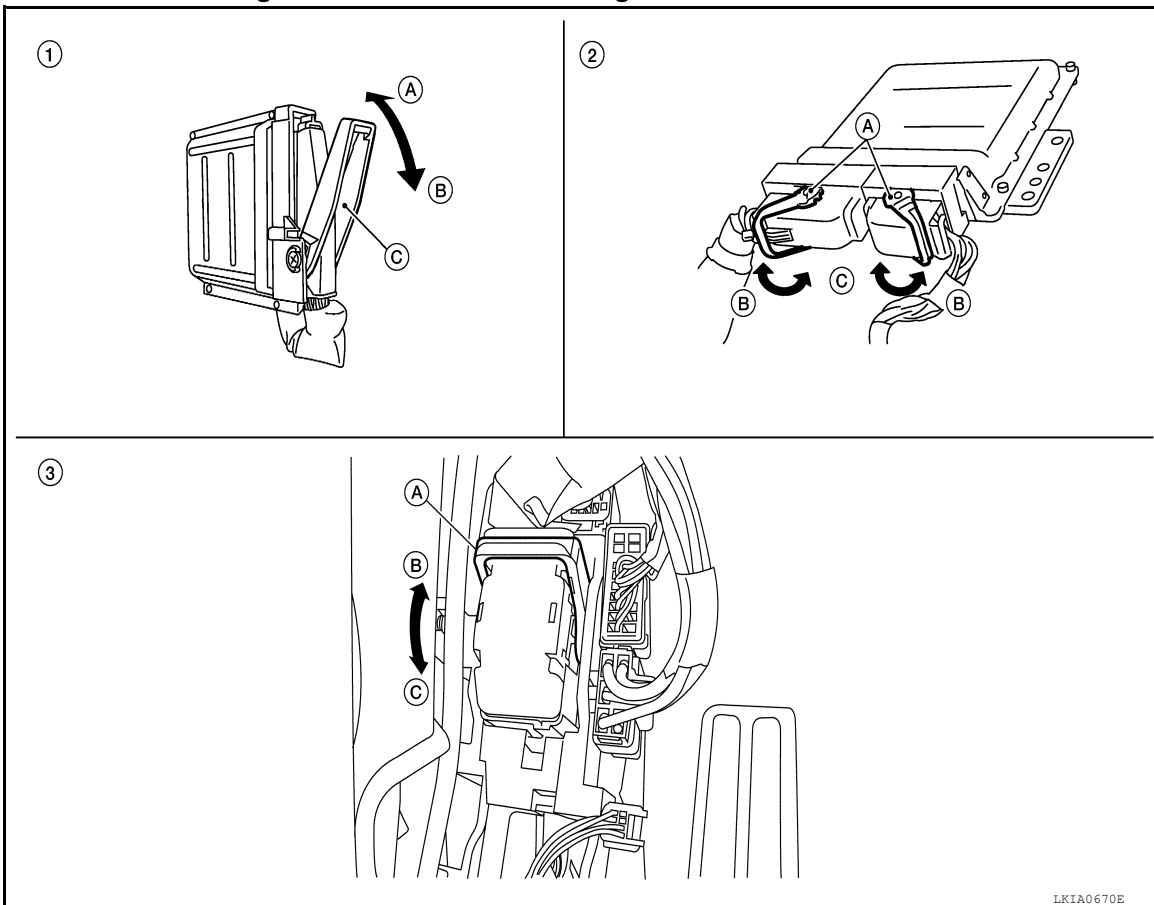

- | | | |
|---|---|--|
| <p>1. Control unit with single lever</p> <ul style="list-style-type: none"> A. Fasten B. Loosen C. Lever | <p>2. Control unit with dual levers</p> <ul style="list-style-type: none"> A. Levers B. Fasten C. Loosen | <p>3. SMJ connector</p> <ul style="list-style-type: none"> A. Lever B. Fasten C. Loosen |
|---|---|--|

HARNES CONNECTOR (DIRECT-CONNECT SRS COMPONENT TYPE)

- SRS direct-connect type harness connectors are used on certain SRS components such as air bag modules and seat belt pre-tensioners.
- Always pull up to release black locking tab prior to removing connector from SRS component.
- Always push down to lock black locking tab after installing connector to SRS component. When locked, the black locking tab is level with the connector housing.

CAUTION:

- Do not pull the harness or wires when removing connectors from SRS components.

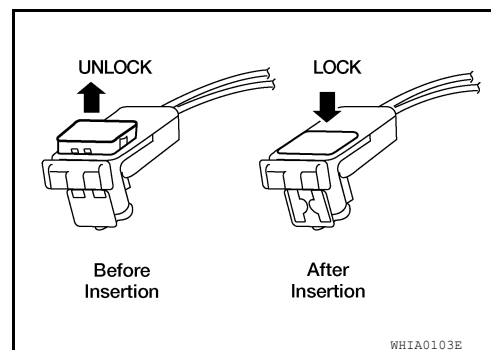

A
B
C
D
E
F
G
H
I
J
K
L
PG
N
O
P

STANDARDIZED RELAY

< DTC/CIRCUIT DIAGNOSIS >

[COUPE]

STANDARDIZED RELAY

Description

INFOID:000000007419556

NORMAL OPEN, NORMAL CLOSED AND MIXED TYPE RELAYS

Relays can mainly be divided into three types: normal open, normal closed and mixed type relays.

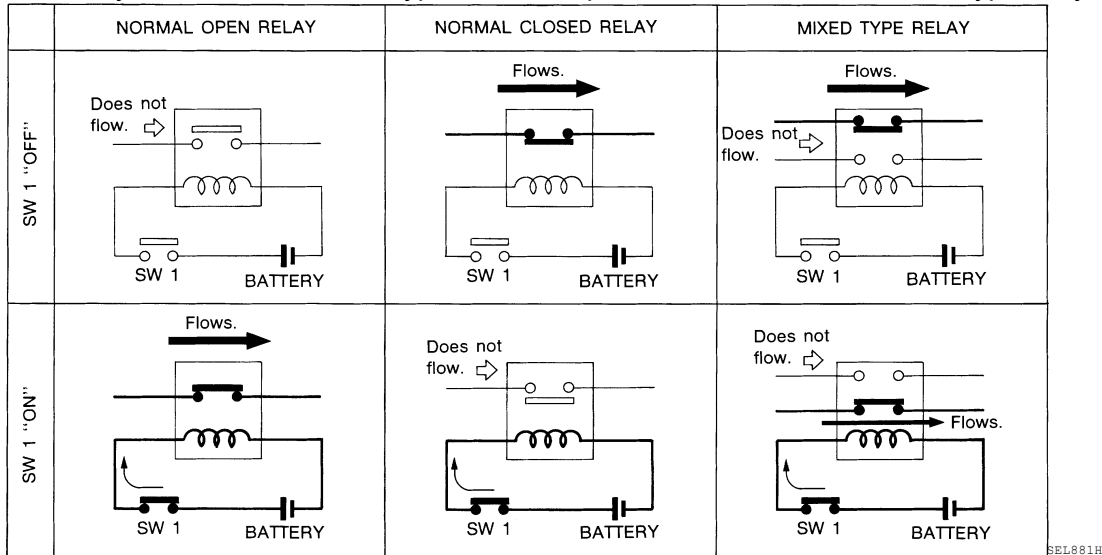

SEL881H

TYPE OF STANDARDIZED RELAYS

- 1M 1 Make
- 2M 2 Make
- 1T 1 Transfer
- 1M·1B 1 Make 1 Break

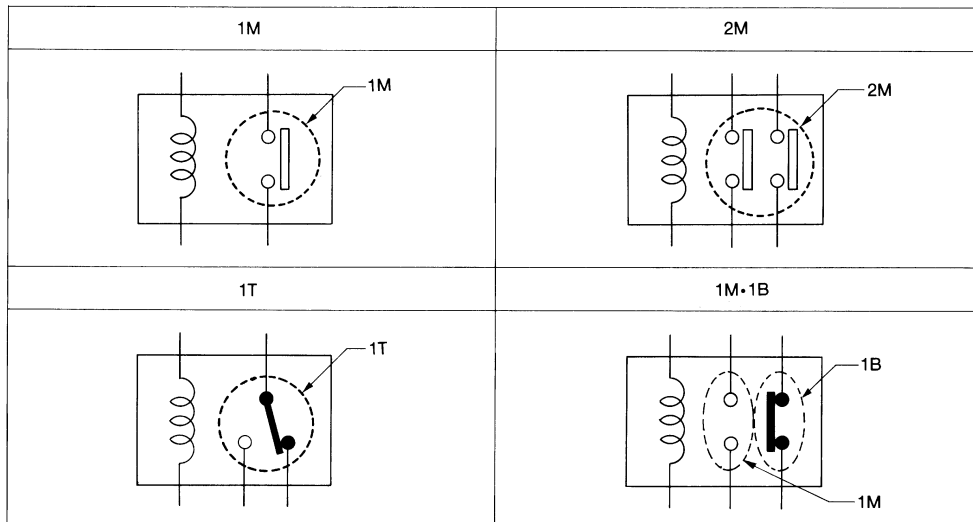

SEL882H

STANDARDIZED RELAY

< DTC/CIRCUIT DIAGNOSIS >

[COUPE]

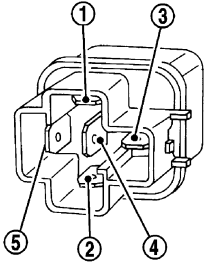
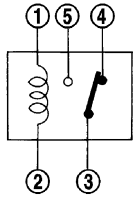
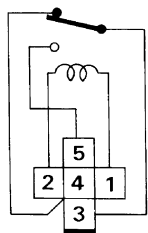
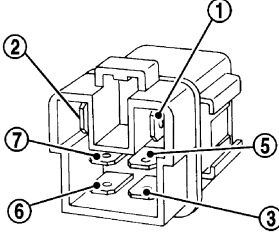
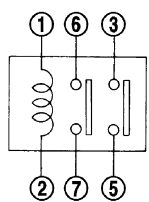
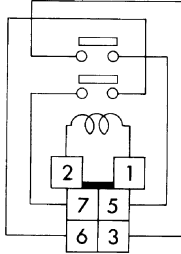
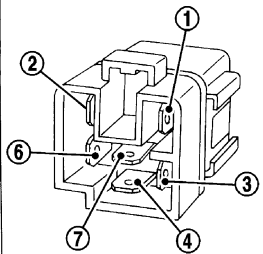
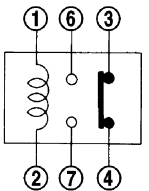
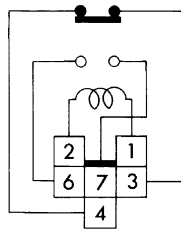
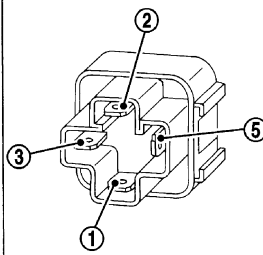
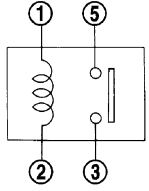
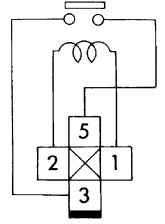
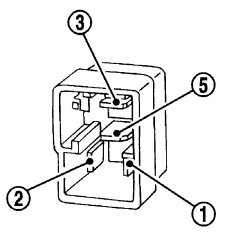
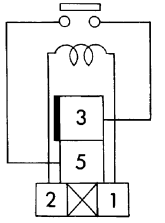
Type	Outer view	Circuit	Connector symbol and connection	Case color
1T				BLACK
2M				BROWN
1M•1B				GRAY
1M				BLUE
				

The arrangement of terminal numbers on the actual relays may differ from those shown above.

SEL188W

A
B
C
D
E
F
G
H
I
J
K
L
PG
N
O
P

FUSE BLOCK - JUNCTION BOX (J/B)

[COUPE]

< DTC/CIRCUIT DIAGNOSIS >

FUSE BLOCK - JUNCTION BOX (J/B)

Terminal Arrangement

INFOID:000000007419557

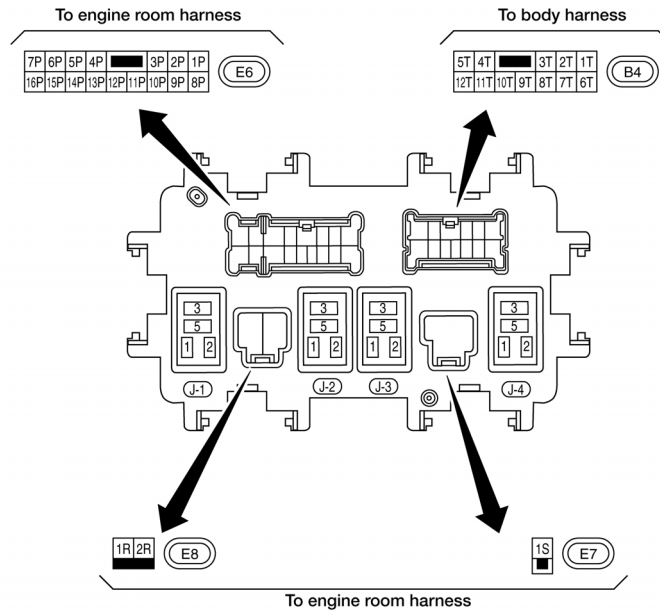
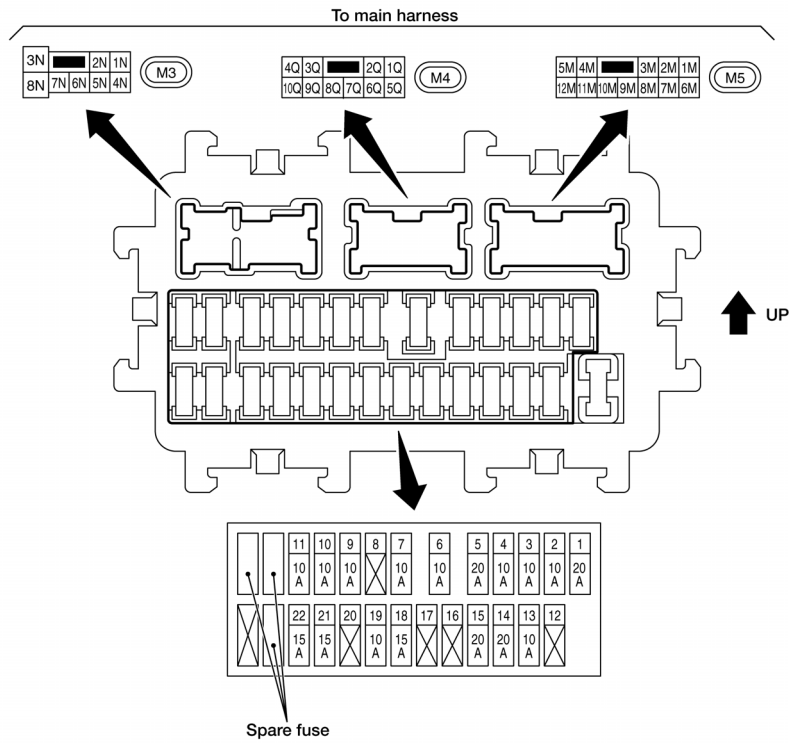

ABMIA2001GB

FUSE, FUSIBLE LINK AND RELAY BOX

< DTC/CIRCUIT DIAGNOSIS >

[COUPE]

FUSE, FUSIBLE LINK AND RELAY BOX

Terminal Arrangement

INFOID:000000007419558

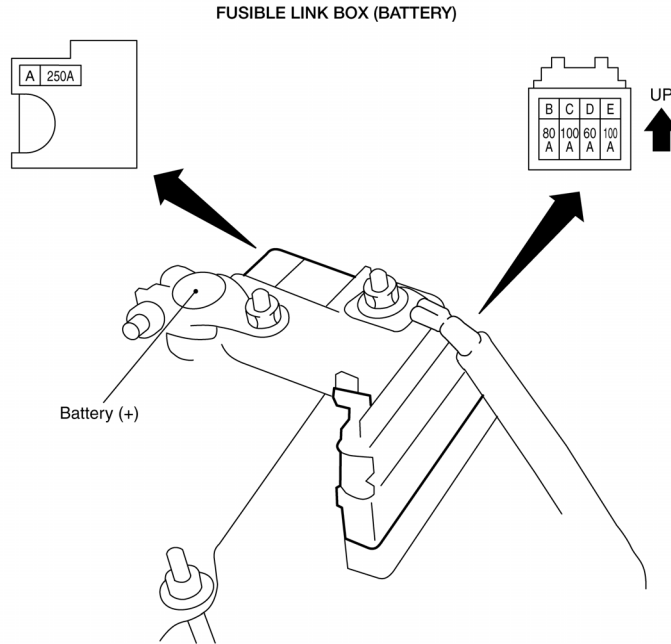

FUSE AND FUSIBLE LINK BOX

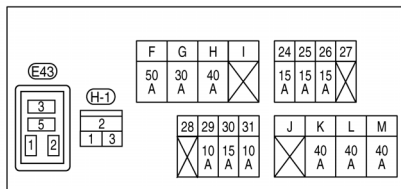

F-M: FUSIBLE LINK
No. 24-31: FUSE

ABMIA2002GB

A
B
C
D
E
F
G
H
I
J
K
L
PG
N
O
P

IPDM E/R (INTELLIGENT POWER DISTRIBUTION MODULE ENGINE ROOM)

< DTC/CIRCUIT DIAGNOSIS >

[COUPE]

IPDM E/R (INTELLIGENT POWER DISTRIBUTION MODULE ENGINE ROOM)

Fuse, Connector and Terminal Arrangement

INFOID:000000007419559

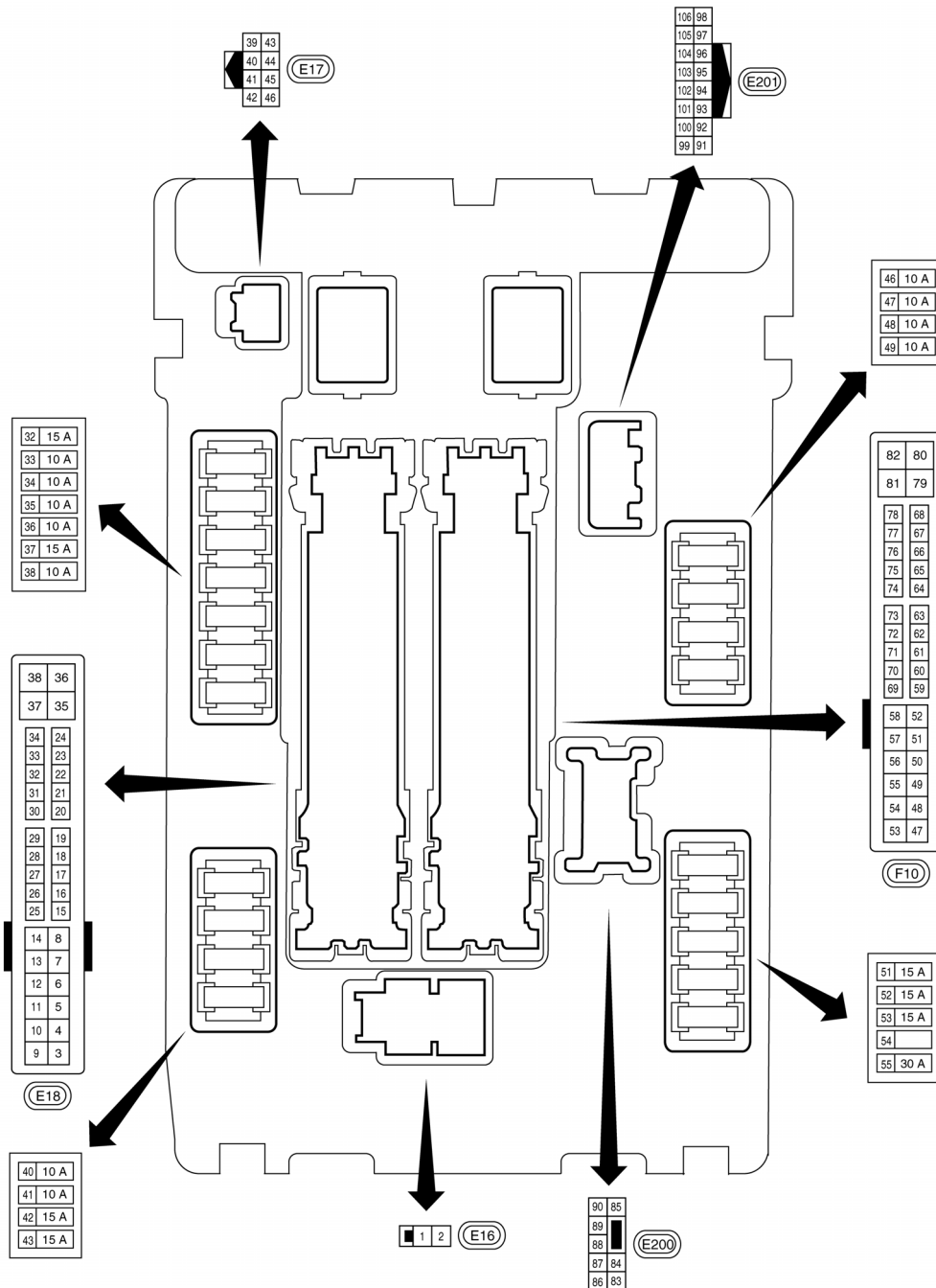

ABMIA2003GB

PRECAUTION

PRECAUTIONS

Precaution for Supplemental Restraint System (SRS) "AIR BAG" and "SEAT BELT PRE-TENSIONER"

INFOID:000000007419560

The Supplemental Restraint System such as "AIR BAG" and "SEAT BELT PRE-TENSIONER", used along with a front seat belt, helps to reduce the risk or severity of injury to the driver and front passenger for certain types of collision. This system includes seat belt switch inputs and dual stage front air bag modules. The SRS system uses the seat belt switches to determine the front air bag deployment, and may only deploy one front air bag, depending on the severity of a collision and whether the front occupants are belted or unbelted. Information necessary to service the system safely is included in the SR and SB section of this Service Manual.

WARNING:

- To avoid rendering the SRS inoperative, which could increase the risk of personal injury or death in the event of a collision which would result in air bag inflation, all maintenance must be performed by an authorized NISSAN/INFINITI dealer.
- Improper maintenance, including incorrect removal and installation of the SRS, can lead to personal injury caused by unintentional activation of the system. For removal of Spiral Cable and Air Bag Module, see the SR section.
- Do not use electrical test equipment on any circuit related to the SRS unless instructed to in this Service Manual. SRS wiring harnesses can be identified by yellow and/or orange harnesses or harness connectors.

PRECAUTIONS WHEN USING POWER TOOLS (AIR OR ELECTRIC) AND HAMMERS

WARNING:

- When working near the Airbag Diagnosis Sensor Unit or other Airbag System sensors with the Ignition ON or engine running, DO NOT use air or electric power tools or strike near the sensor(s) with a hammer. Heavy vibration could activate the sensor(s) and deploy the air bag(s), possibly causing serious injury.
- When using air or electric power tools or hammers, always switch the Ignition OFF, disconnect the battery, and wait at least 3 minutes before performing any service.

Precaution Necessary for Steering Wheel Rotation After Battery Disconnect

INFOID:000000007419561

NOTE:

- Before removing and installing any control units, first turn the push-button ignition switch to the LOCK position, then disconnect both battery cables.
- After finishing work, confirm that all control unit connectors are connected properly, then re-connect both battery cables.
- Always use CONSULT to perform self-diagnosis as a part of each function inspection after finishing work. If a DTC is detected, perform trouble diagnosis according to self-diagnosis results.

This vehicle is equipped with a push-button ignition switch and a steering lock unit.

If the battery is disconnected or discharged, the steering wheel will lock and cannot be turned.

If turning the steering wheel is required with the battery disconnected or discharged, follow the procedure below before starting the repair operation.

OPERATION PROCEDURE

1. Connect both battery cables.

NOTE:

Supply power using jumper cables if battery is discharged.

2. Carry the Intelligent Key or insert it to the key slot and turn the push-button ignition switch to ACC position. (At this time, the steering lock will be released.)
3. Disconnect both battery cables. The steering lock will remain released with both battery cables disconnected and the steering wheel can be turned.
4. Perform the necessary repair operation.

A
B
C
D
E
F
G
H
I
J
K
L
PG
N
O
P

PRECAUTIONS

[COUPE]

< PRECAUTION >

5. When the repair work is completed, re-connect both battery cables. With the brake pedal released, turn the push-button ignition switch from ACC position to ON position, then to LOCK position. (The steering wheel will lock when the push-button ignition switch is turned to LOCK position.)
6. Perform self-diagnosis check of all control units using CONSULT.

Battery Service

INFOID:000000007419562

Before disconnecting the battery, lower both the driver and passenger windows. This will prevent any interference between the window edge and the vehicle when the door is opened/closed. During normal operation, the window slightly raises and lowers automatically to prevent any window to vehicle interference. The automatic window function will not work with the battery disconnected.

PREPARATION

< PREPARATION >

[COUPE]

PREPARATION

PREPARATION

Special Service Tool

INFOID:000000007419563

The actual shapes of Kent-Moore tools may differ from those of special service tools illustrated here.

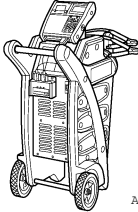
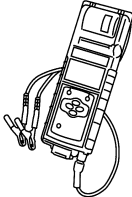
Tool number (Kent Moore No.) Tool name	Description
<p>— (—) Model GR8-1200 NI Multitasking battery and electrical diagnostic station</p>  <p style="text-align: right; font-size: small;">AWIIA12392Z</p>	<p>Tests batteries, starting and charging systems and charges batteries. For operating instructions, refer to diagnostic station instruction manual.</p>
<p>— (—) Model EXP-800 NI Battery and electrical diagnostic analyzer</p>  <p style="text-align: right; font-size: small;">JSMIA08062Z</p>	<p>Tests batteries and charging systems. For operating instructions, refer to diagnostic analyzer instruction manual.</p>

Commercial Service Tool

INFOID:000000007419564

Tool name	Description
<p>Power tool</p>  <p style="text-align: right; font-size: small;">PIIB1407E</p>	<p>Loosening nuts, screws and bolts</p>

A
B
C
D
E
F
G
H
I
J
K
L
PG
N
O
P

REMOVAL AND INSTALLATION

BATTERY

Exploded View

INFOID:000000007419565

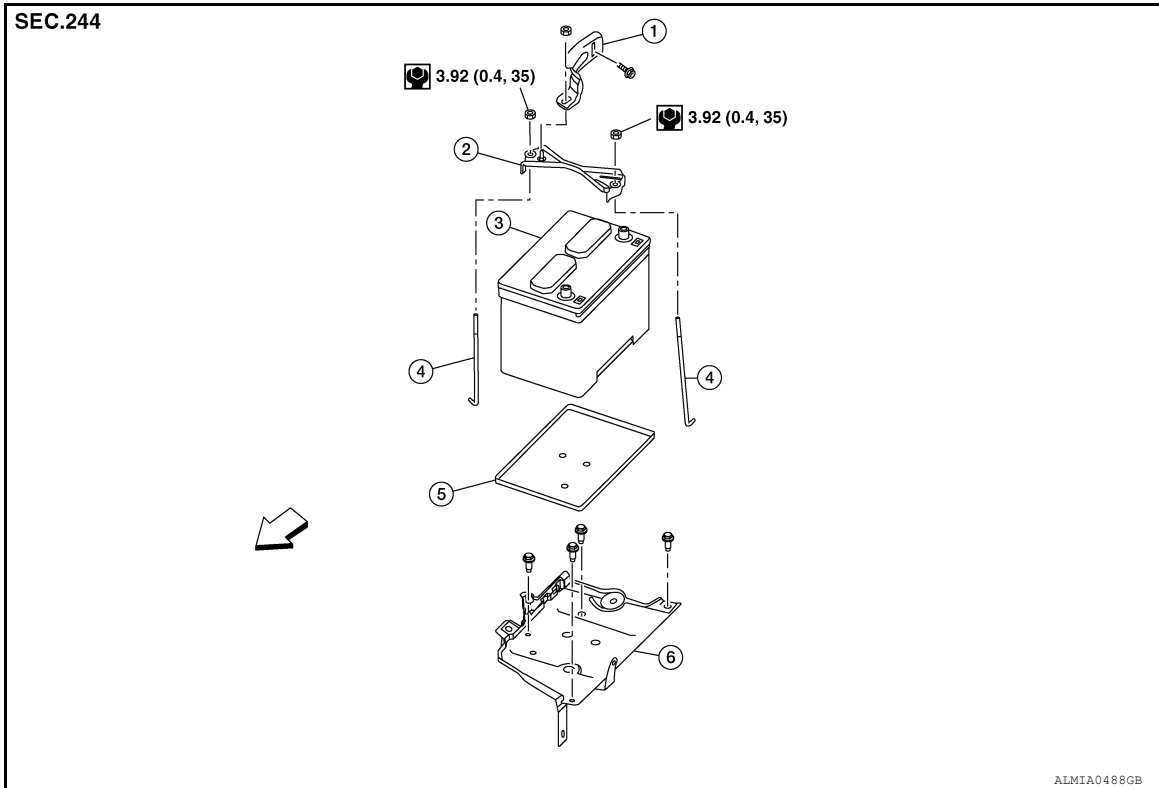

- | | | |
|----------------------|-----------------------|-----------------|
| 1. Upper ECM bracket | 2. Battery frame | 3. Battery |
| 4. Battery rods | 5. Battery tray liner | 6. Battery tray |
- ⇐ Front

Removal and Installation (Battery)

INFOID:000000007419566

REMOVAL

1. Disconnect the battery negative and positive terminals.
CAUTION:
Disconnect the negative terminal first.
2. Remove battery frame nuts and battery frame.
3. Remove battery.

INSTALLATION

Installation is in the reverse order of removal.

CAUTION:

When connecting, connect the battery positive terminal first.

Battery frame nut : 3.92 N·m (0.4 kg-m, 35 in-lb)

Battery terminal nut : 5.4 N·m (0.55 kg-m, 48 in-lb)

Reset electronic systems as necessary. Refer to [PG-74. "ADDITIONAL SERVICE WHEN REMOVING BATTERY NEGATIVE TERMINAL : Special Repair Requirement"](#).

Removal and Installation (Battery Tray)

INFOID:000000007419567

REMOVAL

1. Remove battery and battery tray liner. Refer to [PG-68, "Removal and Installation \(Battery\)"](#).
2. Remove air cleaner assembly. Refer to [EM-25, "Removal and Installation"](#) (QR25DE models) or [EM-132, "Removal and Installation"](#) (VQ35DE models).
3. Disconnect and remove ECM.
4. Disconnect transmission control module (TCM) (CVT models). Refer to [TM-238, "Removal and Installation"](#) (RE0F09B) or [TM-403, "Removal and Installation"](#) (RE0F10A).
5. Remove the ECM bracket.
6. Remove current sensor from battery tray.
7. Remove the battery tray bolts and battery tray.

INSTALLATION

Installation is in the reverse order of removal.

Reset electronic systems as necessary. Refer to [PG-6, "ADDITIONAL SERVICE WHEN REMOVING BATTERY NEGATIVE TERMINAL : Special Repair Requirement"](#).

A
B
C
D
E
F
G
H
I
J
K
L

PG

N
O
P

BATTERY

< SERVICE DATA AND SPECIFICATIONS (SDS)

[COUPE]

SERVICE DATA AND SPECIFICATIONS (SDS)

BATTERY

Battery

INFOID:000000007419568

Type*	GR 35
Capacity (20HR) minimum V-AH	12 - 60
Cold cranking current A @ -18°C (0°F)	550

*: Always check with the Parts Department for the latest parts information

BASIC INSPECTION

BATTERY

How to Handle Battery

INFOID:000000009326006

CAUTION:

- If it becomes necessary to start the engine with a booster battery and jumper cables, use a 12-volt booster battery.
- After connecting battery cables, ensure that they are tightly clamped to battery terminals for good contact.
- Never add distilled water through the hole used to check specific gravity.

METHODS OF PREVENTING OVER-DISCHARGE

- The following precautions must be taken to prevent over-discharging a battery.
- The battery surface (particularly its top) should always be kept clean and dry.
 - The terminal connections should be clean and tight.
 - At every routine maintenance, check the electrolyte level. This also applies to batteries designated as "low maintenance" and "maintenance-free".

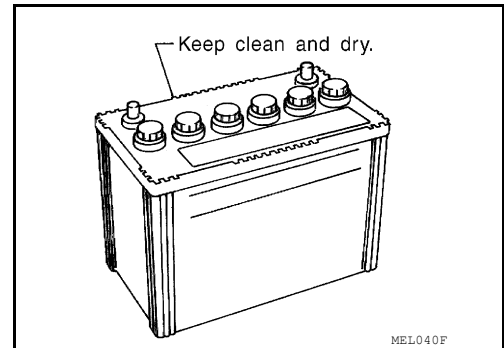

- When the vehicle is not going to be used over a long period of time, disconnect the battery cable from the negative terminal. (If the vehicle has an extended storage switch, turn it off.)

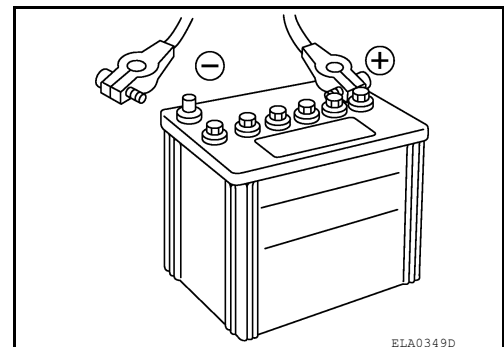

Work Flow

INFOID:000000009326004

BATTERY DIAGNOSIS WITH EXP-800 NI OR GR8-1200 NI

To diagnose and confirm the condition of the battery, use the following special service tools:

- EXP-800 NI Battery and electrical diagnostic analyzer
- GR8-1200 NI Multitasking battery and electrical diagnostic station

NOTE:

Refer to the applicable Instruction Manual for proper battery diagnosis procedures.

BATTERY DIAGNOSIS WITHOUT EXP-800 NI OR GR8-1200 NI

Checking Electrolyte Level

WARNING:

Never allow battery fluid to come in contact with skin, eyes, fabrics, or painted surfaces. After touching a battery, never touch or rub your eyes until you have thoroughly washed your hands. If acid contacts eyes, skin or clothing, immediately flush with water for 15 minutes and seek medical attention. Failure to do this may cause personal injury or damage to clothing or the painted surfaces.

A
B
C
D
E
F
G
H
I
J
K
L

PG

N
O
P

BATTERY

[SEDAN]

< BASIC INSPECTION >

- Remove the cell plug using a suitable tool.
- Add distilled water up to the MAX level.

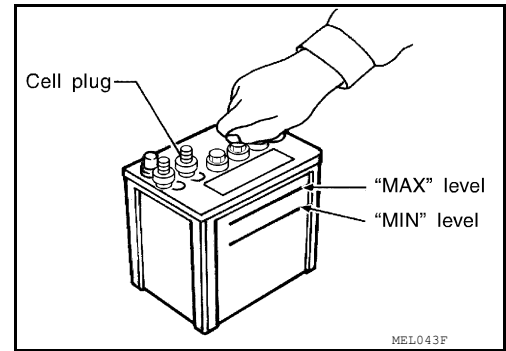

SULFATION

- A battery will be completely discharged if it is left unattended for a long time and the specific gravity will become less than 1.100. This may result in sulfation on the cell plates.
- To determine if a battery has been “sulfated”, note its voltage and current when charging it. As shown in the figure, less current and higher voltage are observed in the initial stage of charging sulfated batteries.
- A sulfated battery may sometimes be brought back into service by means of a long, slow charge, 12 hours or more, followed by a battery capacity test.

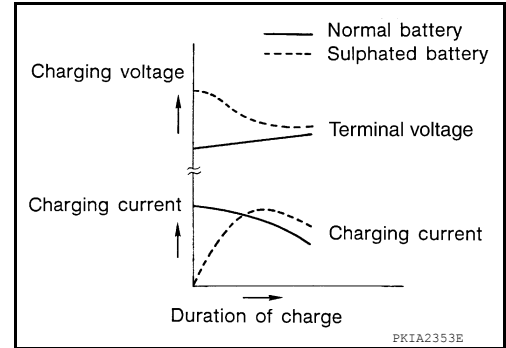

Specific Gravity Check

NOTE:

Check the charge condition of the battery.

Periodically check the specific gravity of the electrolyte. Keep a close check on charge condition to prevent over-discharge.

1. Read hydrometer and thermometer indications at eye level.
2. Use the chart below to correct your hydrometer reading according to electrolyte temperature.

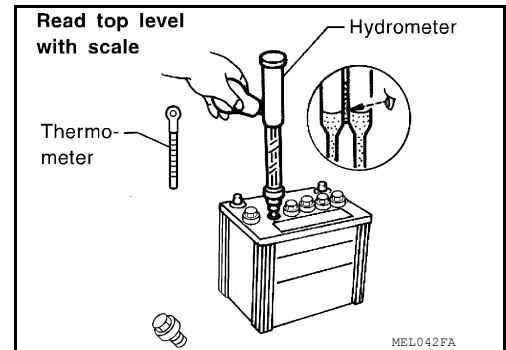

Hydrometer Temperature Correction

Battery electrolyte temperature [°C (°F)]	Add to specific gravity reading
71 (160)	0.032
66 (150)	0.028
60 (140)	0.024
54 (130)	0.020
49 (120)	0.016
43 (110)	0.012
38 (100)	0.008
32 (90)	0.004
27 (80)	0
21 (70)	-0.004
16 (60)	-0.008
10 (50)	-0.012

BATTERY

< BASIC INSPECTION >

[SEDAN]

Battery electrolyte temperature [°C (°F)]	Add to specific gravity reading
4 (40)	-0.016
-1 (30)	-0.020
-7 (20)	-0.024
-12 (10)	-0.028
-18 (0)	-0.032

Corrected specific gravity	Approximate charge condition
1.260 - 1.280	Fully charged
1.230 - 1.250	3/4 charged
1.200 - 1.220	1/2 charged
1.170 - 1.190	1/4 charged
1.140 - 1.160	Almost discharged
1.110 - 1.130	Completely discharged

Charging The Battery

CAUTION:

- **Never “quick charge” a fully discharged battery.**
- **Keep the battery away from open flame while it is being charged.**
- **When connecting the charger, connect the leads first, then turn on the charger. Never turn on the charger first, as this may cause a spark.**
- **If battery electrolyte temperature rises above 55 °C (131 °F), stop charging. Always charge battery at a temperature below 55 °C (131 °F).**

Charging Rates (Standard Charge)

Approximate charge condition	Charge current (A)	Charge time (h)
Fully charged	7	2
3/4 charged		2.5
1/2 charged		5
1/4 charged		7.5
Almost discharged		9
Completely discharged		10

Charging Rates (Quick Charge)

Approximate charge condition	Charge current (A)	Charge time (h)
Fully charged	—	—
3/4 charged	16	0.5
1/2 charged	33	
1/4 charged		
Almost discharged	—	—
Completely discharged	—	

NOTE:

The ammeter reading on your battery charger will automatically decrease as the battery charges. This indicates that the voltage of the battery is increasing normally as the state of charge improves. The charging amps indicated above refer to initial charge rate.

- If, after charging, the specific gravity of any two cells varies more than 0.050, the battery should be replaced.

A
B
C
D
E
F
G
H
I
J
K
L
N
O
P

PG

INSPECTION AND ADJUSTMENT

< BASIC INSPECTION >

[SEDAN]

INSPECTION AND ADJUSTMENT

ADDITIONAL SERVICE WHEN REMOVING BATTERY NEGATIVE TERMINAL

ADDITIONAL SERVICE WHEN REMOVING BATTERY NEGATIVE TERMINAL : Special Repair Requirement

INFOID:000000007419571

Required Procedure After Battery Disconnection

System	Item	Reference
Engine Control System	Idle Air Volume Learning	EC-20 (QR25DE) EC-335 (VQ35DE)
Power Window Control System	Power Window System Initialization	PWC-11 (LH only Anti-Pinch) PWC-197 (LH & RH Front Anti-Pinch)
Roof	Sunroof Memory Reset/Initialization	RF-6
Heater & Air Conditioning Control System	Temperature Setting Trimmer	HAC-6
	Foot Position Setting Trimmer	HAC-6
	Inlet Port Memory Function	HAC-6
Audio, Visual & Navigation System	Audio (Radio Preset)	Refer to Owner's Manual.
	Navigation System	Refer to Owner's Manual.

DTC/CIRCUIT DIAGNOSIS

POWER SUPPLY ROUTING CIRCUIT

Wiring Diagram —Battery Power Supply—

INFOID:000000007419572

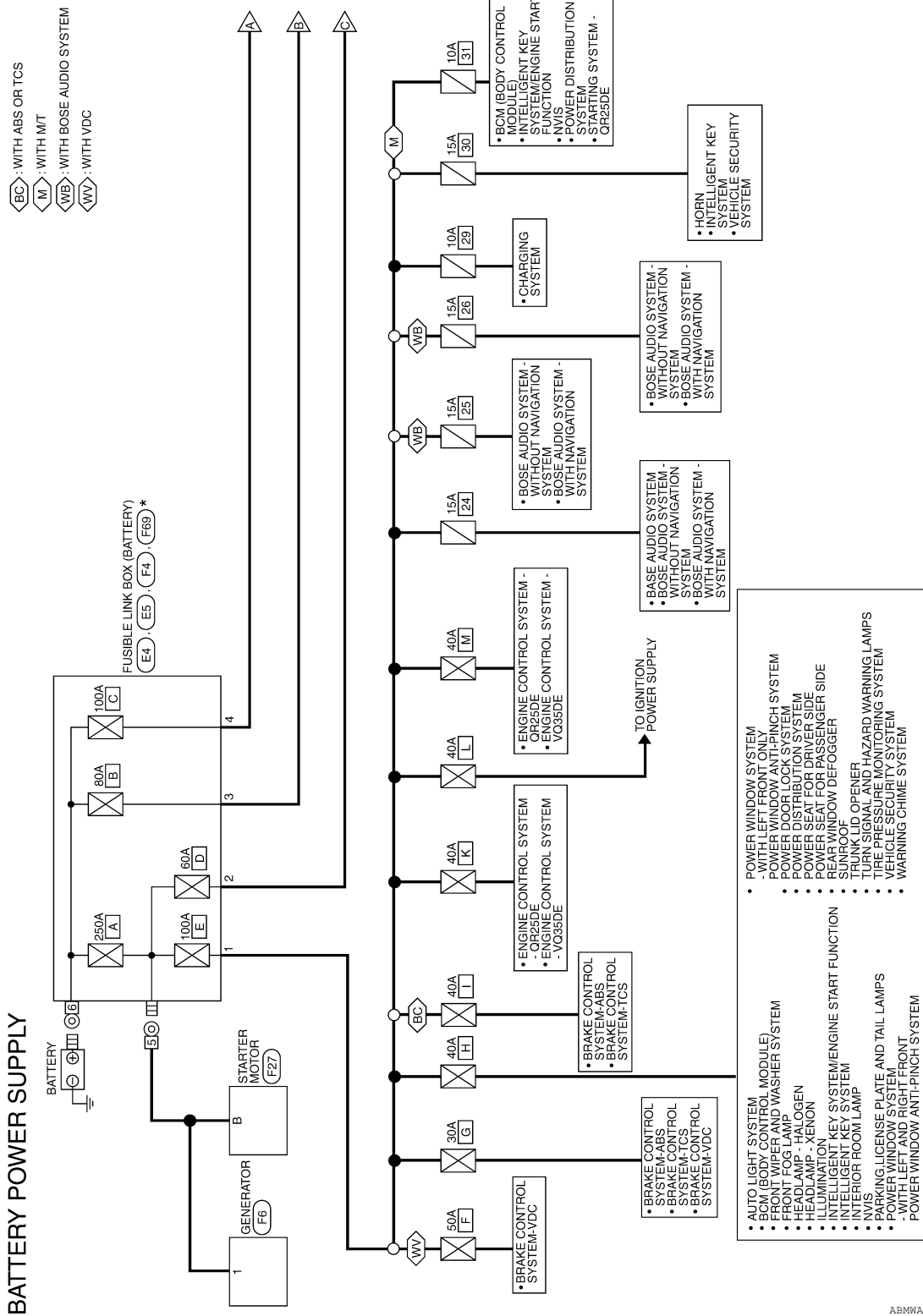

*: (F69) IS AN INTEGRAL PART OF FUSIBLE LINK BOX (BATTERY) ASSEMBLY.

ABMWA1336GB

A
B
C
D
E
F
G
H
I
J
K
L
M
N
O
P

PG

POWER SUPPLY ROUTING CIRCUIT

< DTC/CIRCUIT DIAGNOSIS >

[SEDAN]

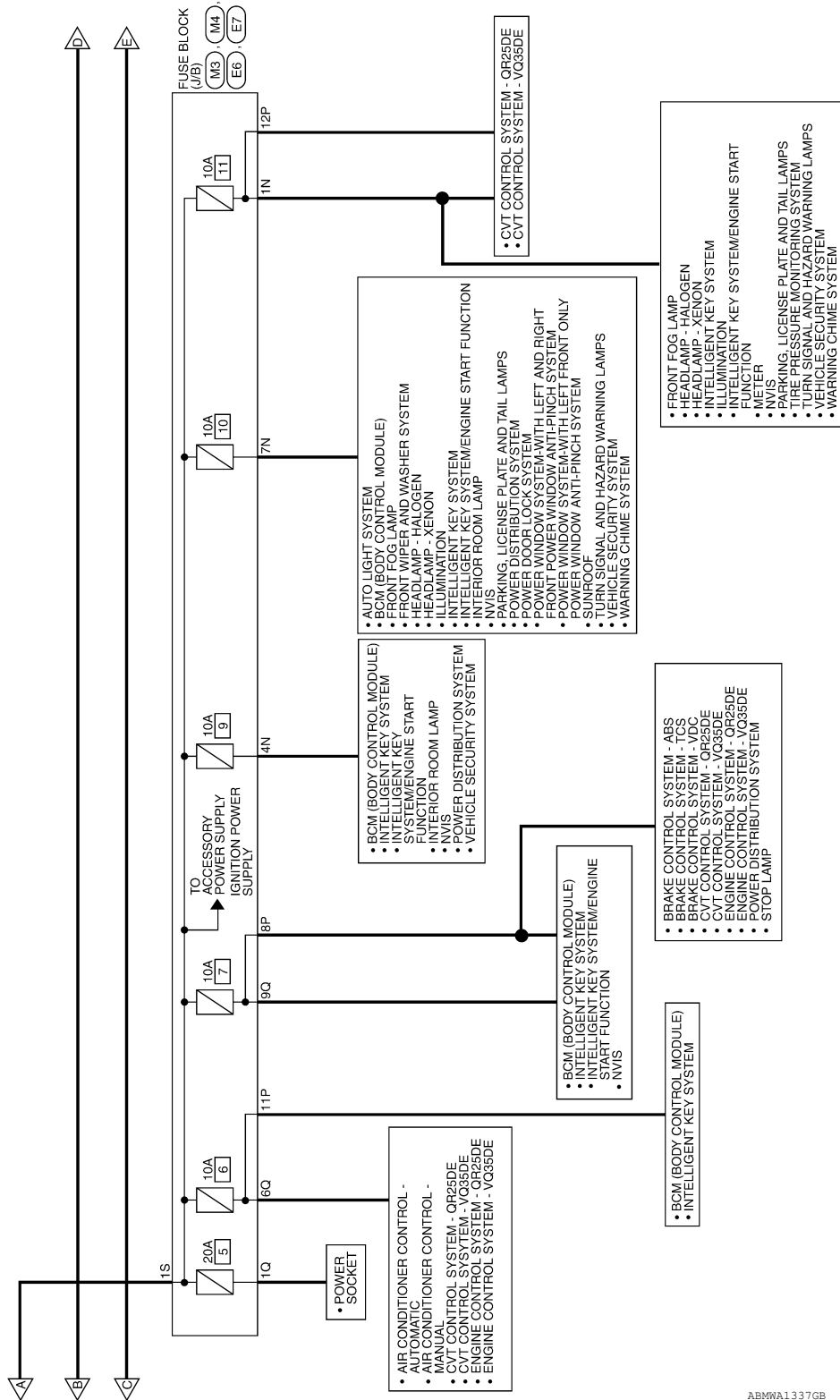

ABMWA1337GB

POWER SUPPLY ROUTING CIRCUIT

< DTC/CIRCUIT DIAGNOSIS >

[SEDAN]

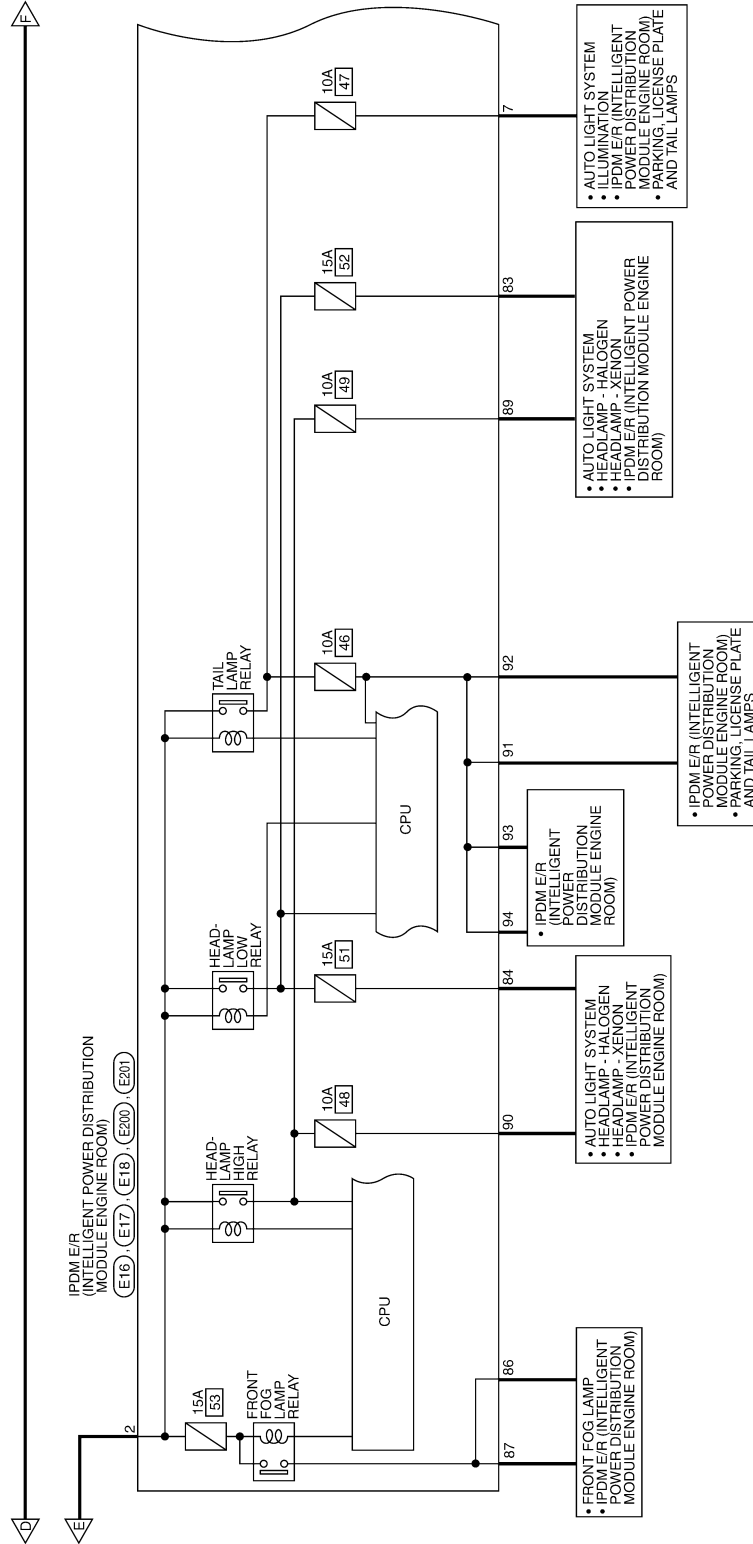

ABMWA1338GB

A
B
C
D
E
F
G
H
I
J
K
L
PG
N
O
P

POWER SUPPLY ROUTING CIRCUIT

< DTC/CIRCUIT DIAGNOSIS >

[SEDAN]

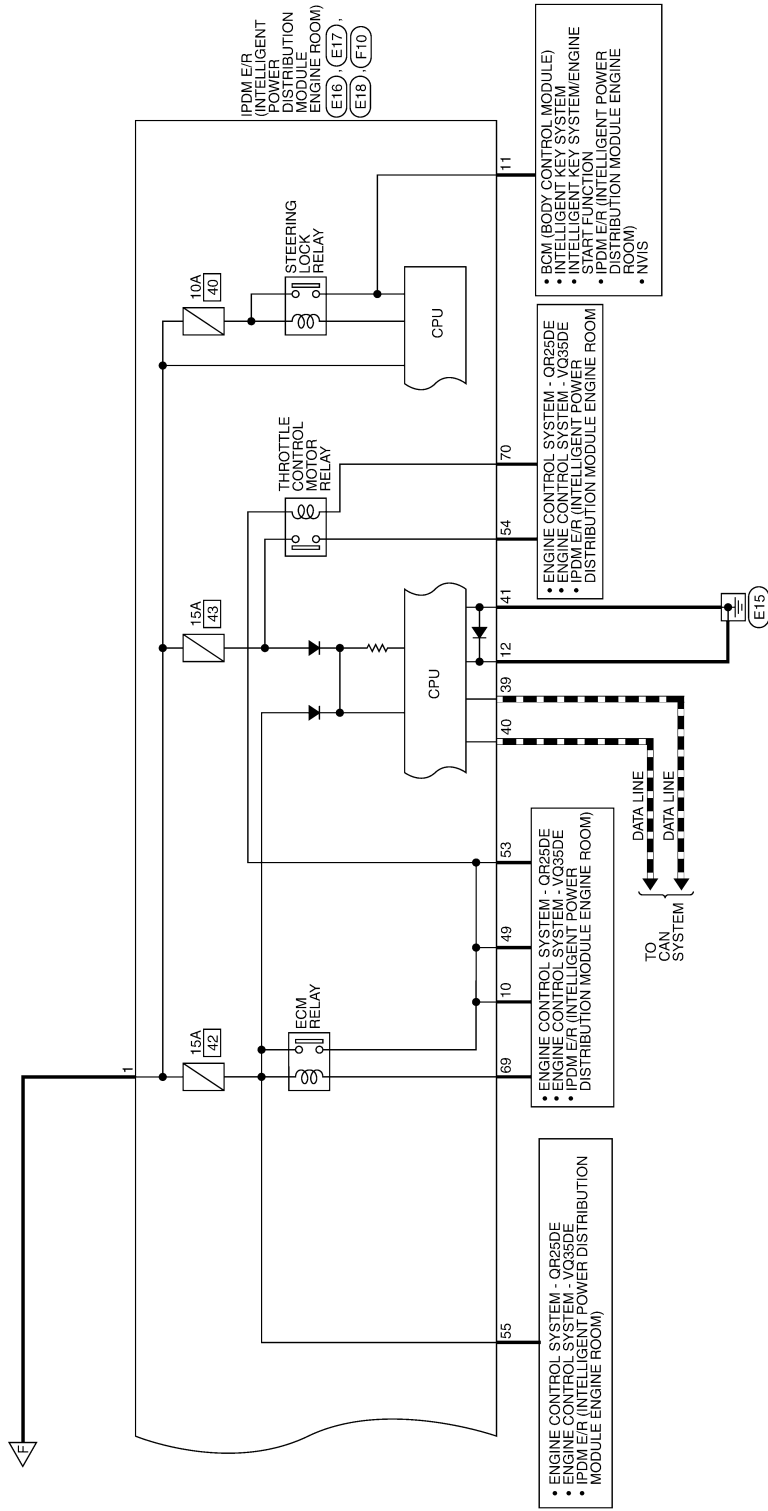

ABMWA0755GB

BATTERY POWER SUPPLY CONNECTORS

Connector No.	M3
Connector Name	FUSE BLOCK (J/B)
Connector Color	WHITE

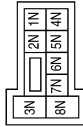

Terminal No.	Color of Wire	Signal Name
1N	W/L	-
4N	G/Y	-
7N	Y/R	-

Connector No.	M4
Connector Name	FUSE BLOCK (J/B)
Connector Color	WHITE

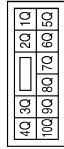

Terminal No.	Color of Wire	Signal Name
1Q	R/W	- (EARLY PRODUCTION)
1Q	L	- (LATE PRODUCTION)
6Q	Y/R	-
9Q	R/W	-

Connector No.	E4
Connector Name	FUSIBLE LINK BOX (BATTERY)
Connector Color	BROWN



Terminal No.	Color of Wire	Signal Name
1	B/W	-
2	L	-

Connector No.	E5
Connector Name	FUSIBLE LINK BOX (BATTERY)
Connector Color	GRAY



Terminal No.	Color of Wire	Signal Name
3	R	-
4	W	-

Connector No.	E6
Connector Name	FUSE BLOCK (J/B)
Connector Color	WHITE



Terminal No.	Color of Wire	Signal Name
8P	R	-
11P	G	-
12P	V	-

Connector No.	E7
Connector Name	FUSE BLOCK (J/B)
Connector Color	WHITE



Terminal No.	Color of Wire	Signal Name
1S	W	-

AAMIA0937GB

A
B
C
D
E
F
G
H
I
J
K
L
PG
N
O
P

POWER SUPPLY ROUTING CIRCUIT

< DTC/CIRCUIT DIAGNOSIS >

[SEDAN]

Connector No.	E16
Connector Name	IPDM E/R (INTELLIGENT POWER DISTRIBUTION MODULE ENGINE ROOM)
Connector Color	BLACK



Terminal No.	Color of Wire	Signal Name
1	R	F/L_MAIN
2	L	F/L_USM

Connector No.	E17
Connector Name	IPDM E/R (INTELLIGENT POWER DISTRIBUTION MODULE ENGINE ROOM)
Connector Color	WHITE



Terminal No.	Color of Wire	Signal Name
39	P	CAN-L
40	L	CAN-H
41	B	GND (SIGNAL)

Connector No.	E18
Connector Name	IPDM E/R (INTELLIGENT POWER DISTRIBUTION MODULE ENGINE ROOM)
Connector Color	WHITE



Terminal No.	Color of Wire	Signal Name
7	GR	TAIL/ILLUMI
10	BR	ECM_VB
11	O	ESCL
12	B	GND (POWER)

Connector No.	E200
Connector Name	IPDM E/R (INTELLIGENT POWER DISTRIBUTION MODULE ENGINE ROOM)
Connector Color	WHITE

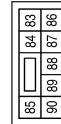

Terminal No.	Color of Wire	Signal Name
83	R/Y	HEADLAMP_LO_RH
84	L	HEADLAMP_LO_LH
86	W/R	FR_FOG_LAMP_RH
87	L/Y	FR_FOG_LAMP_LH
89	L/W	HEADLAMP_HI_RH
90	G	HEADLAMP_HI_LH

Connector No.	E201
Connector Name	IPDM E/R (INTELLIGENT POWER DISTRIBUTION MODULE ENGINE ROOM)
Connector Color	WHITE

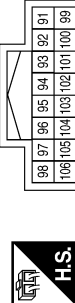

Terminal No.	Color of Wire	Signal Name
91	LG/R	CLEARANCE_RH
92	LG/B	CLEARANCE_LH

ABMIA3272GB

POWER SUPPLY ROUTING CIRCUIT

< DTC/CIRCUIT DIAGNOSIS >

[SEDAN]

Connector No.	F6
Connector Name	GENERATOR
Connector Color	-



Terminal No.	Color of Wire	Signal Name
1	B/R	BATT

Connector No.	F4
Connector Name	FUSIBLE LINK BOX (BATTERY)
Connector Color	-



Terminal No.	Color of Wire	Signal Name
5	B/R	-

Connector No.	F27
Connector Name	STARTER MOTOR
Connector Color	-

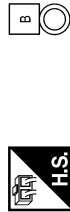

Terminal No.	Color of Wire	Signal Name
B	B/R	BAT

Terminal No.	Color of Wire	Signal Name
49	V	ENG SOL (WITH QR25DE)
49	V	IGN_COIL (WITH VQ35DE)
53	V	IGN_COIL (WITH QR25DE)
53	G	ENG_SOL (WITH VQ35DE)
54	GR	ETC
55	LG	ECM_BAT
69	SB	SSOF
70	G	MOTRLY

Connector No.	F10
Connector Name	IPDM E/R (INTELLIGENT POWER DISTRIBUTION MODULE ENGINE ROOM)
Connector Color	WHITE

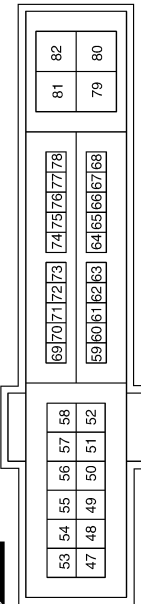

ABMIA1952GB

A
B
C
D
E
F
G
H
I
J
K
L
N
O
P

PG

POWER SUPPLY ROUTING CIRCUIT

< DTC/CIRCUIT DIAGNOSIS >

[SEDAN]

Wiring Diagram —Accessory Power Supply—

INFOID:000000007419573

ACCESSORY POWER SUPPLY

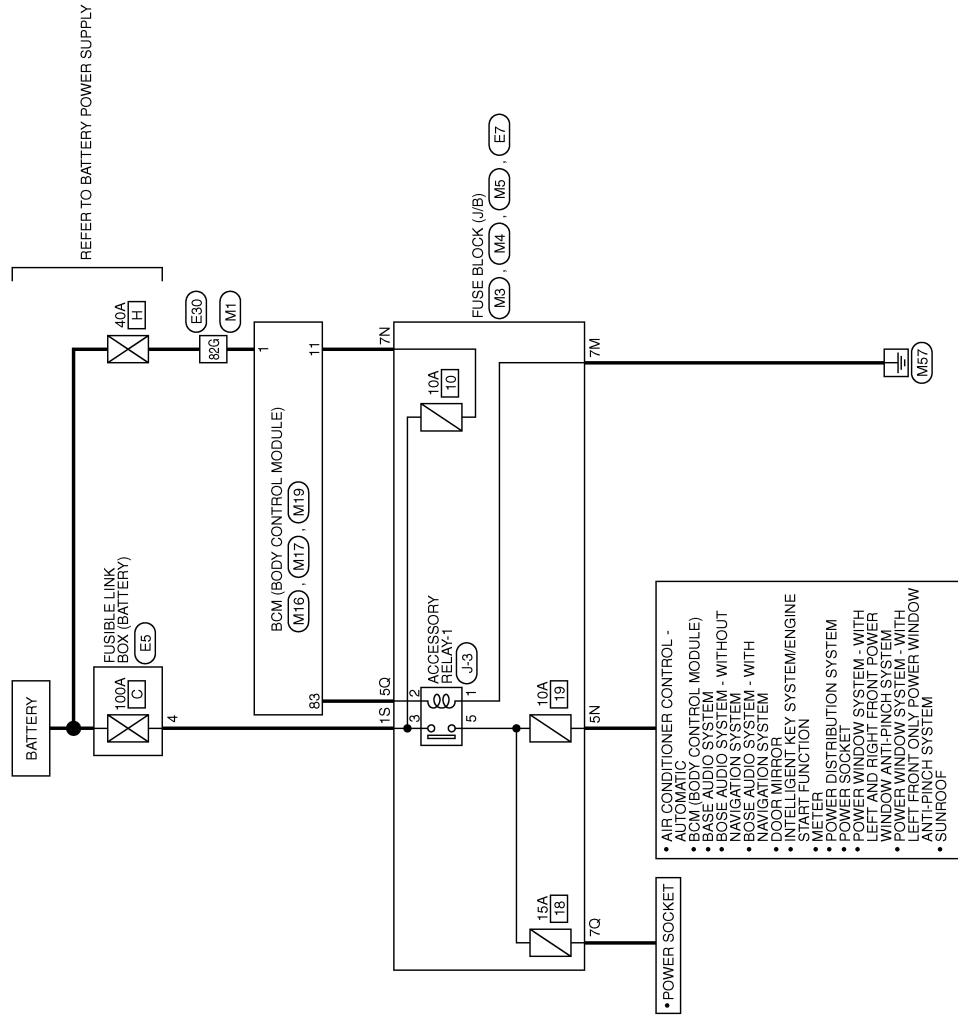

ABMWA1965GB

ACCESSORY POWER SUPPLY CONNECTORS

Connector No.	M1
Connector Name	WIRE TO WIRE
Connector Color	WHITE

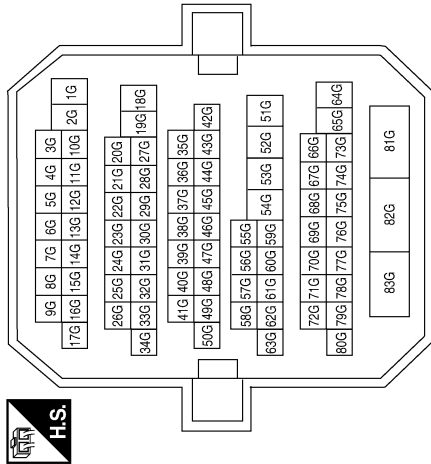

Connector No.	M3
Connector Name	FUSE BLOCK (J/B)
Connector Color	WHITE

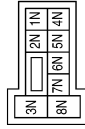

Terminal No.	Color of Wire	Signal Name
5N	V/Y	-
7N	Y/R	-

Connector No.	M4
Connector Name	FUSE BLOCK (J/B)
Connector Color	WHITE

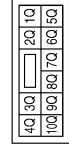

Terminal No.	Color of Wire	Signal Name
5Q	L	-
7Q	R/B	-

Terminal No.	Color of Wire	Signal Name
82G	W/B	-

Connector No.	M5
Connector Name	FUSE BLOCK (J/B)
Connector Color	WHITE

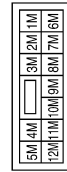

Terminal No.	Color of Wire	Signal Name
7M	B	-

Connector No.	M16
Connector Name	BCM (BODY CONTROL MODULE)
Connector Color	BLACK



Terminal No.	Color of Wire	Signal Name
1	W/B	BAT_POWER_FL

Connector No.	M17
Connector Name	BCM (BODY CONTROL MODULE)
Connector Color	WHITE

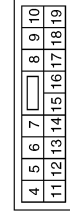

Terminal No.	Color of Wire	Signal Name
11	Y/R	BAT_BCM_FUSE

ABMIA0756GB

A
B
C
D
E
F
G
H
I
J
K
L
N
O
P

POWER SUPPLY ROUTING CIRCUIT

< DTC/CIRCUIT DIAGNOSIS >

[SEDAN]

Connector No.	E7
Connector Name	FUSE BLOCK (J/B)
Connector Color	WHITE



Terminal No.	1S	Color of Wire	W	Signal Name	-
--------------	----	---------------	---	-------------	---

Connector No.	E5
Connector Name	FUSIBLE LINK BOX (BATTERY)
Connector Color	GRAY



Terminal No.	4	Color of Wire	W	Signal Name	-
--------------	---	---------------	---	-------------	---

Connector No.	M19
Connector Name	BCM (BODY CONTROL MODULE)
Connector Color	BLACK

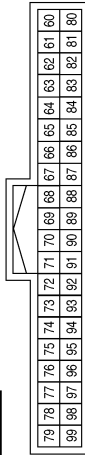

Terminal No.	83	Color of Wire	L	Signal Name	ACC_CONT
--------------	----	---------------	---	-------------	----------

Connector No.	J-3
Connector Name	FUSE BLOCK (J/B) (ACCESSORY RELAY-1)
Connector Color	-

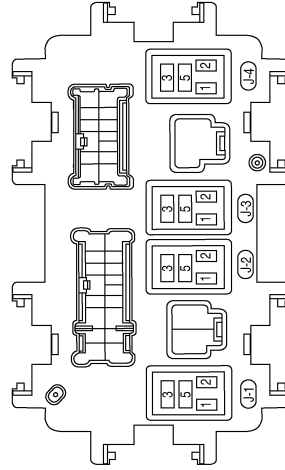

Terminal No.	82G	Color of Wire	LG	Signal Name	-
--------------	-----	---------------	----	-------------	---

Connector No.	E30
Connector Name	WIRE TO WIRE
Connector Color	WHITE

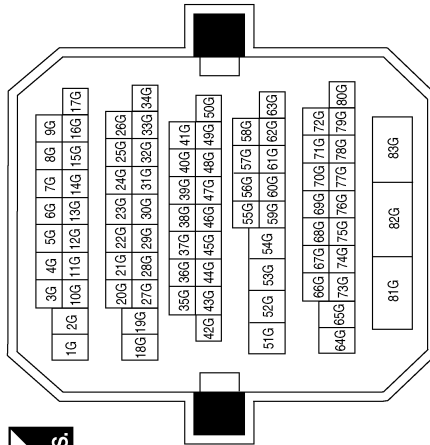

ABMIA4559GB

POWER SUPPLY ROUTING CIRCUIT

< DTC/CIRCUIT DIAGNOSIS >

[SEDAN]

Wiring Diagram — Ignition Power Supply —

INFOID:00000007419574

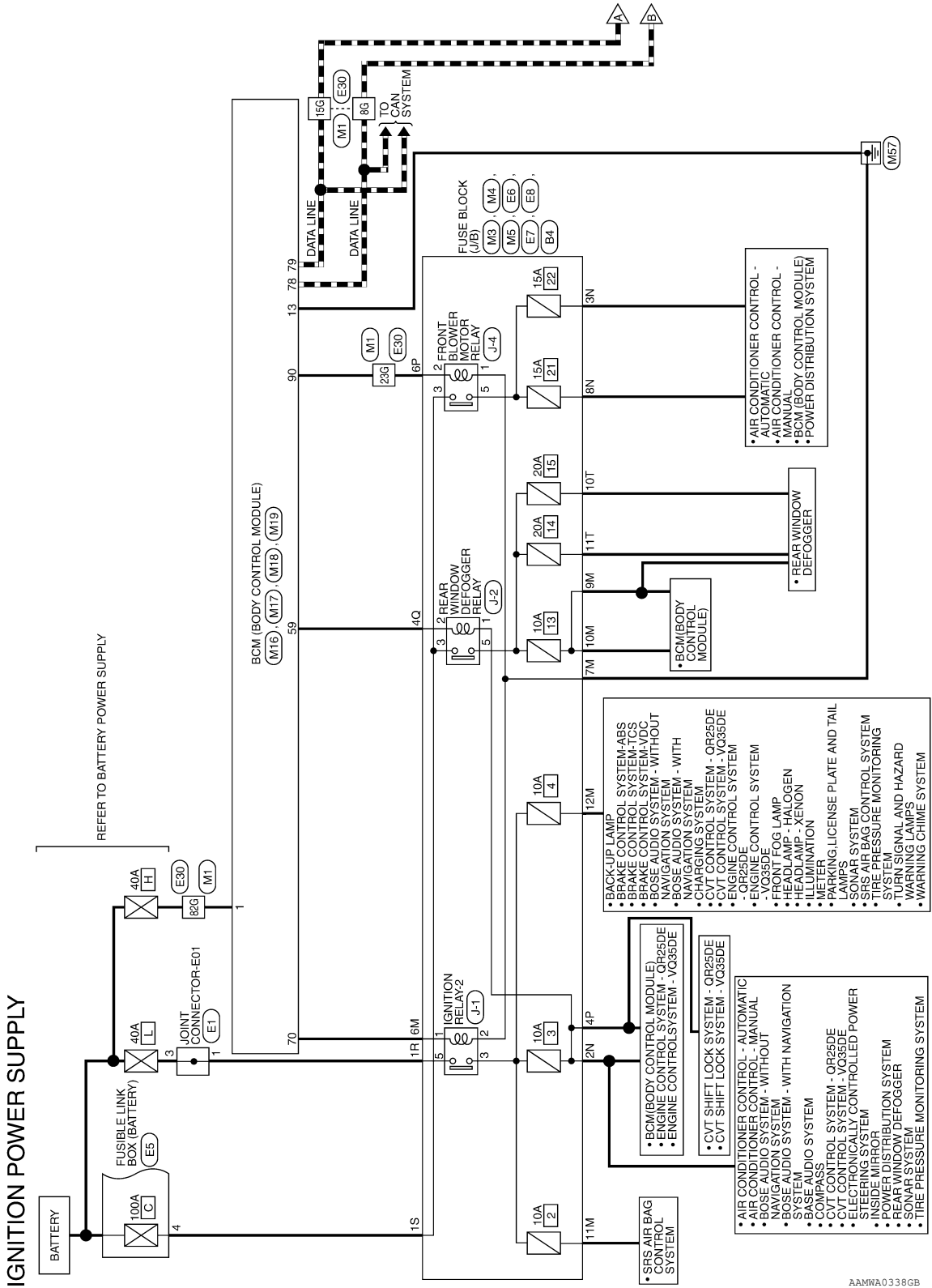

AAMWA0338GB

A
B
C
D
E
F
G
H
I
J
K
L
M
N
O
P

PG

POWER SUPPLY ROUTING CIRCUIT

< DTC/CIRCUIT DIAGNOSIS >

[SEDAN]

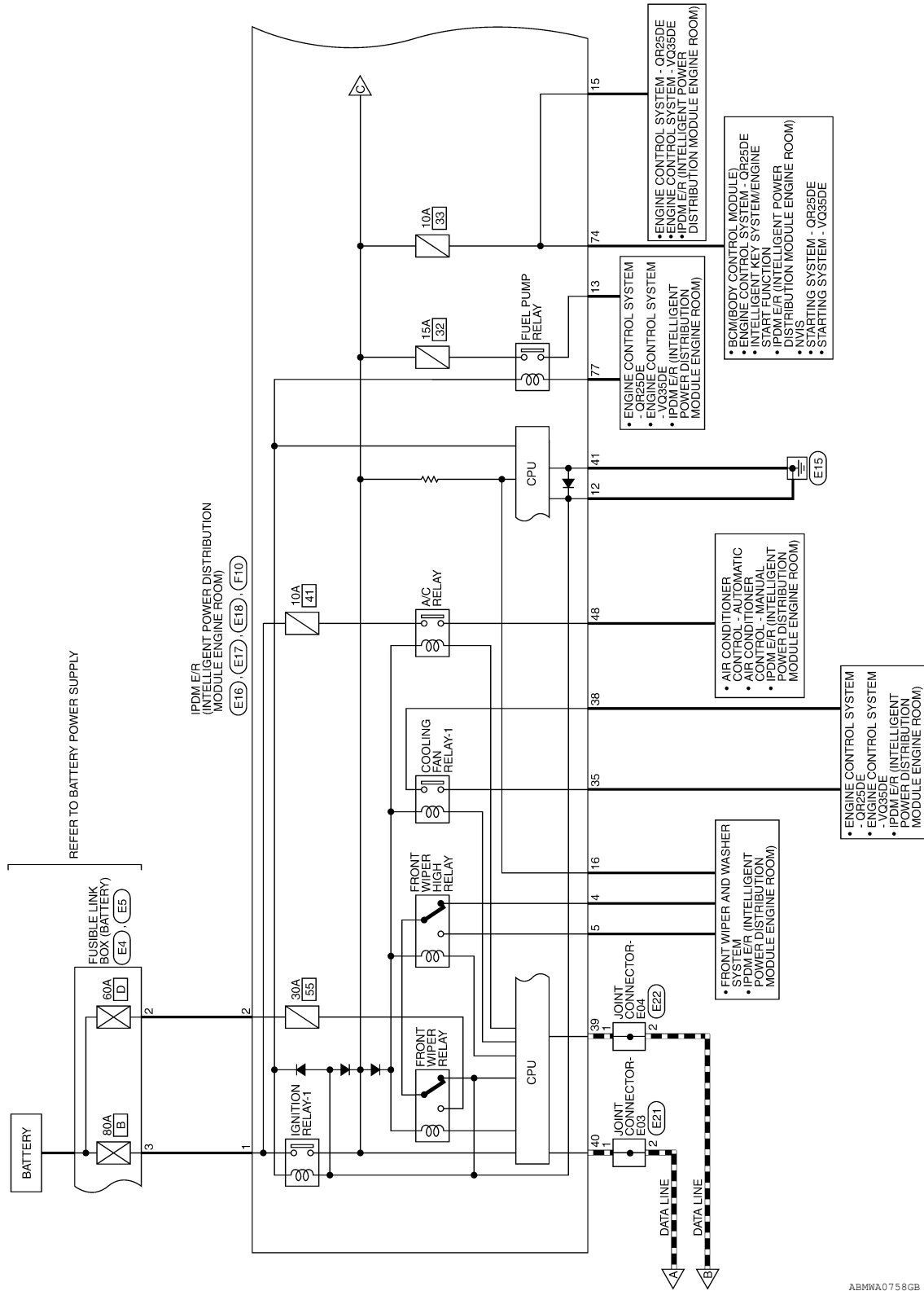

ABMWA0758GB

POWER SUPPLY ROUTING CIRCUIT

< DTC/CIRCUIT DIAGNOSIS >

[SEDAN]

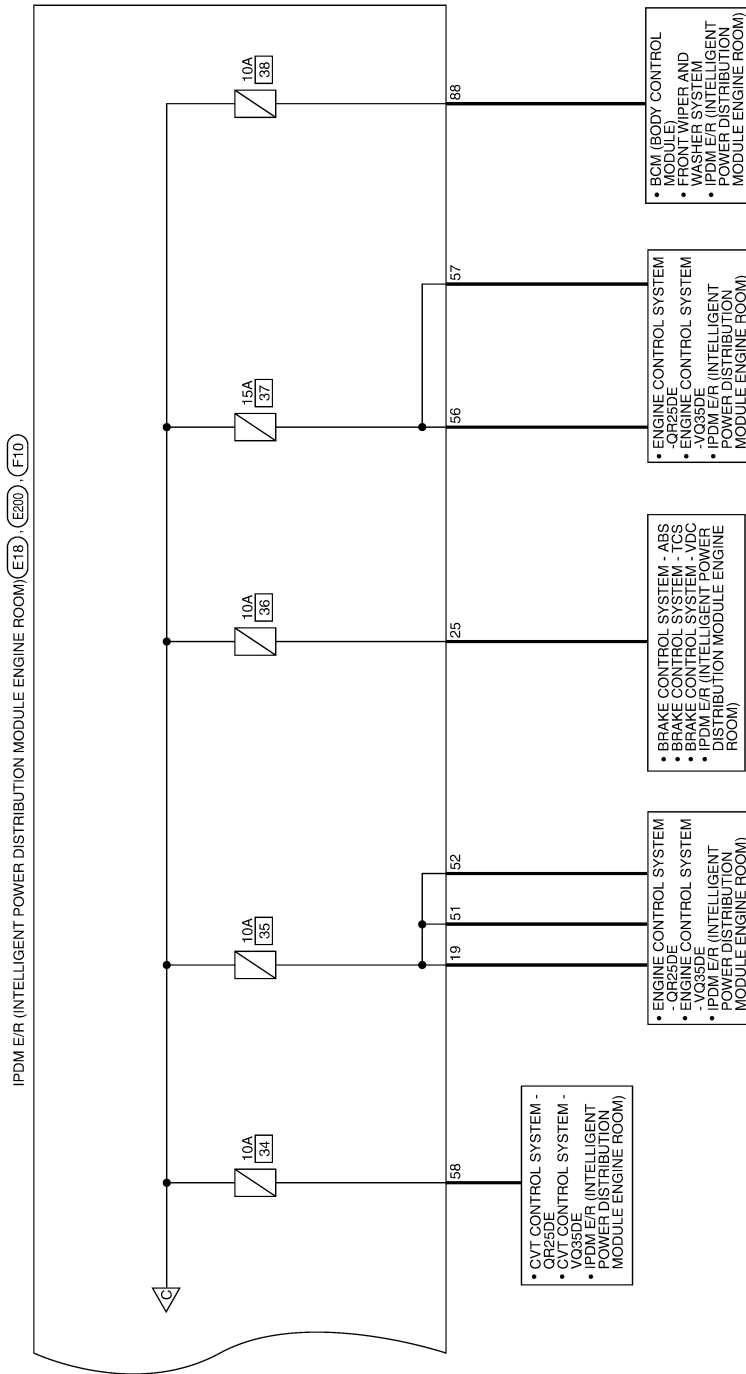

AAMWA0339GB

A
B
C
D
E
F
G
H
I
J
K
L
PG
N
O
P

IGNITION POWER SUPPLY CONNECTORS

Connector No.	M1
Connector Name	WIRE TO WIRE
Connector Color	WHITE

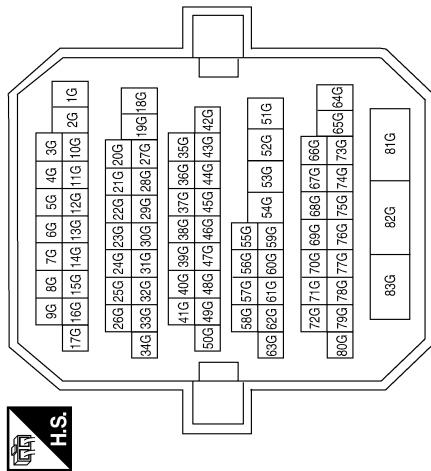

Terminal No.	Color of Wire	Signal Name
8G	P	-
15G	L	-
23G	Y	-
82G	W/B	-

Connector No.	M3
Connector Name	FUSE BLOCK (J/B)
Connector Color	WHITE

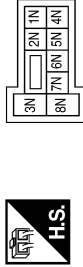

Terminal No.	Color of Wire	Signal Name
2N	G	-
3N	W/L	-
8N	W/L	-

Connector No.	M4
Connector Name	FUSE BLOCK (J/B)
Connector Color	WHITE



Terminal No.	Color of Wire	Signal Name
4Q	G/R	-

Connector No.	M5
Connector Name	FUSE BLOCK (J/B)
Connector Color	WHITE



Terminal No.	Color of Wire	Signal Name
6M	R/B	-
7M	B	-
9M	GR	-
10M	L/Y	-
11M	R/L	-
12M	O	-

Connector No.	M16
Connector Name	BCM (BODY CONTROL MODULE)
Connector Color	BLACK



Terminal No.	Color of Wire	Signal Name
1	W/B	BAT_POWER_FL

POWER SUPPLY ROUTING CIRCUIT

< DTC/CIRCUIT DIAGNOSIS >

[SEDAN]

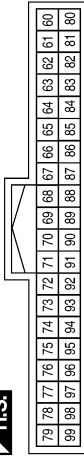

Connector No.	M19
Connector Name	BCM (BODY CONTROL MODULE)
Connector Color	BLACK

79	78	77	76	75	74	73	72	71	70	69	68	67	66	65	64	63	62	61	60
99	98	97	96	95	94	93	92	91	90	89	88	87	86	85	84	83	82	81	80

Terminal No.	Color of Wire	Signal Name
70	R/B	IGN_ELEC_CONT
78	P	CAN-L
79	L	CAN-H
90	Y	IGN2_CONT

Connector No.	E5
Connector Name	FUSIBLE LINK BOX (BATTERY)
Connector Color	GRAY

Terminal No.	Color of Wire	Signal Name
3	R	-
4	W	-

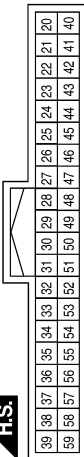

Connector No.	M18
Connector Name	BCM (BODY CONTROL MODULE)
Connector Color	GREEN

39	38	37	36	35	34	33	32	31	30	29	28	27	26	25	24	23	22	21	20
59	58	57	56	55	54	53	52	51	50	49	48	47	46	45	44	43	42	41	40

Terminal No.	Color of Wire	Signal Name
59	G/R	REAR_DEFGGER_RLY

Connector No.	E4
Connector Name	FUSIBLE LINK BOX (BATTERY)
Connector Color	BROWN

Terminal No.	Color of Wire	Signal Name
2	L	-

Connector No.	M17
Connector Name	BCM (BODY CONTROL MODULE)
Connector Color	WHITE

Terminal No.	Color of Wire	Signal Name
13	B	GND 1

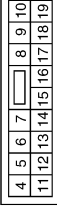
Connector No.	E1
Connector Name	JOINT CONNECTOR-E01
Connector Color	WHITE



Terminal No.	Color of Wire	Signal Name
1	G	-
3	G	-

ABMIA1955GB

A
B
C
D
E
F
G
H
I
J
K
L
M
N
O
P

PG

POWER SUPPLY ROUTING CIRCUIT

< DTC/CIRCUIT DIAGNOSIS >

[SEDAN]

Connector No.	E8
Connector Name	FUSE BLOCK (J/B)
Connector Color	BLACK



Terminal No.	Color of Wire	Signal Name
1R	G	-

Connector No.	E7
Connector Name	FUSE BLOCK (J/B)
Connector Color	WHITE



Terminal No.	Color of Wire	Signal Name
1S	W	-

Connector No.	E6
Connector Name	FUSE BLOCK (J/B)
Connector Color	WHITE



Terminal No.	Color of Wire	Signal Name
4P	P	-
6P	Y	-

Connector No.	E18
Connector Name	IPDM E/R (INTELLIGENT POWER DISTRIBUTION MODULE ENGINE ROOM)
Connector Color	WHITE

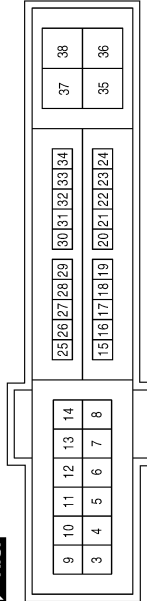

Terminal No.	Color of Wire	Signal Name
4	LG	FR_WIPER_LO
5	Y	FR_WIPER_HI
12	B	GND (POWER)
13	SB	FUEL_PUMP
15	W	SART_IG-E/R
16	R	WIPER_AUTOSTOP
19	Y	BCM_IGNSW
25	GR	ABS_ECU
35	P	MOTOR_FAN_LO
38	GR	F/L_MOTOR_FAN

Connector No.	E17
Connector Name	IPDM E/R (INTELLIGENT POWER DISTRIBUTION MODULE ENGINE ROOM)
Connector Color	WHITE



Terminal No.	Color of Wire	Signal Name
39	P	CAN-L
40	L	CAN-H
41	B	GND (SIGNAL)

Connector No.	E16
Connector Name	IPDM E/R (INTELLIGENT POWER DISTRIBUTION MODULE ENGINE ROOM)
Connector Color	BLACK



Terminal No.	Color of Wire	Signal Name
1	R	F/L_MAIN
2	L	F/L_USM

ABMIA3273GB

POWER SUPPLY ROUTING CIRCUIT

< DTC/CIRCUIT DIAGNOSIS >

[SEDAN]

Connector No.	E22
Connector Name	JOINT CONNECTOR-E04
Connector Color	WHITE



Terminal No.	Color of Wire	Signal Name
1	P	-
2	P	-

Connector No.	E21
Connector Color	JOINT CONNECTOR-E03
Connector Name	WHITE



Terminal No.	Color of Wire	Signal Name
1	L	-
2	L	-

Connector No.	E200
Connector Name	IPDM E/R (INTELLIGENT POWER DISTRIBUTION MODULE ENGINE ROOM)
Connector Color	WHITE

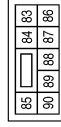

Terminal No.	Color of Wire	Signal Name
88	R/W	WASHER_MTR

Terminal No.	Color of Wire	Signal Name
8G	P	-
15G	L	-
23G	Y	-
82G	LG	-

Connector No.	E30
Connector Name	WIRE TO WIRE
Connector Color	WHITE

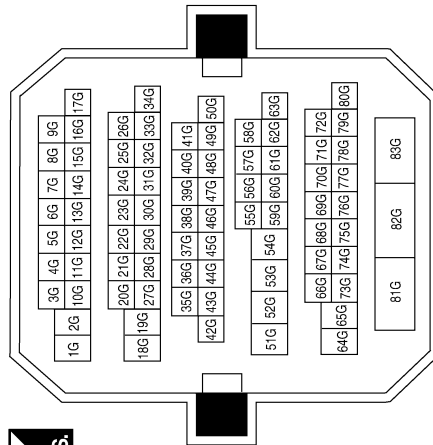

ABMIA0761GB

A
B
C
D
E
F
G
H
I
J
K
L
N
O
P

PG

POWER SUPPLY ROUTING CIRCUIT

< DTC/CIRCUIT DIAGNOSIS >

[SEDAN]

Connector No.	B4
Connector Name	FUSE BLOCK (J/B)
Connector Color	BROWN

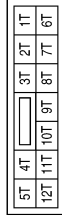

Terminal No.	Color of Wire	Signal Name
10T	Y	-
11T	Y	-

Terminal No.	Color of Wire	Signal Name
48	W	A/C_COMP
51	SB	INJECTOR_#1
52	Y	INJECTOR_#2
56	R	O2_SENS_#1
57	O	O2_SENS_#2
58	BR	AT_ECU
74	L	START_IG-EGI
77	B/R	FPR

Connector No.	F10
Connector Name	IPDM E/R (INTELLIGENT POWER DISTRIBUTION MODULE ENGINE ROOM)
Connector Color	WHITE

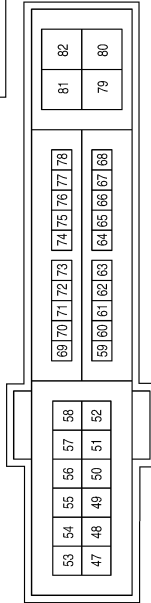

Connector No.	J-4
Connector Name	FUSE BLOCK (J/B) (FRONT BLOWER MOTOR RELAY)
Connector Color	-

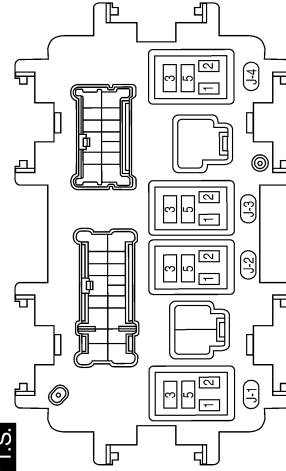

Connector No.	J-2
Connector Name	FUSE BLOCK (J/B) (REAR WINDOW DEFOGGER RELAY)
Connector Color	-

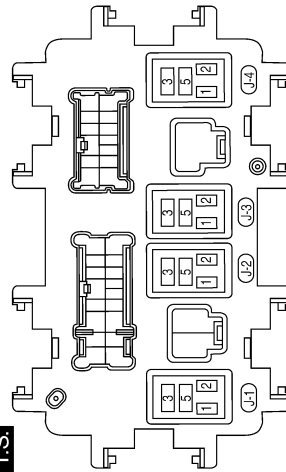

Connector No.	J-1
Connector Name	FUSE BLOCK (J/B) (IGNITION RELAY-2)
Connector Color	-

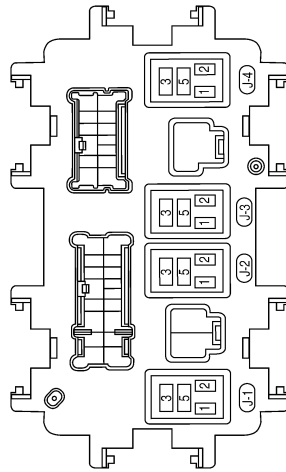

ABMIA3274GB

POWER SUPPLY ROUTING CIRCUIT

< DTC/CIRCUIT DIAGNOSIS >

[SEDAN]

Fuse

INFOID:000000007419575

- If fuse is blown, be sure to eliminate cause of malfunction before installing new fuse.
- Use fuse of specified rating. Never use fuse of more than specified rating.
- Do not partially install fuse; always insert it into fuse holder properly.
- Remove fuse for "ELECTRICAL PARTS (BAT)" if vehicle is not used for a long period of time.

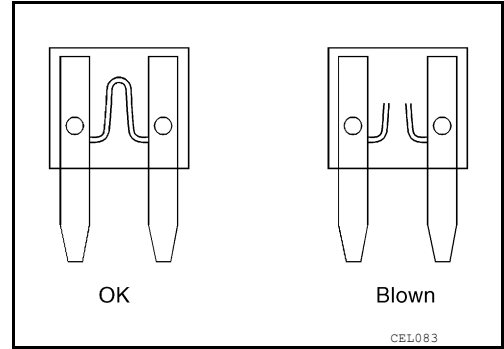

Fusible Link

INFOID:000000007419576

A melted fusible link can be detected either by visual inspection or by feeling with finger tip. If its condition is questionable, use circuit tester or test lamp.

1 : Fusible link

⇐ Front

CAUTION:

- If fusible link should melt, it is possible that critical circuit (power supply or large current carrying circuit) is shorted. In such a case, carefully check and eliminate cause of malfunction.
- Never wrap outside of fusible link with vinyl tape. Important: Never let fusible link touch any other wiring harness, vinyl or rubber parts.

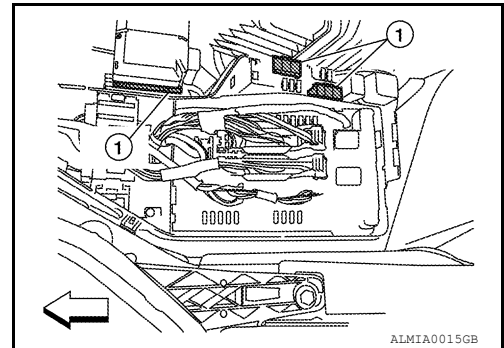

A
B
C
D
E
F
G
H
I
J
K
L
N
O
P

PG

GROUND

Ground Distribution

INFOID:000000007419577

MAIN HARNESS

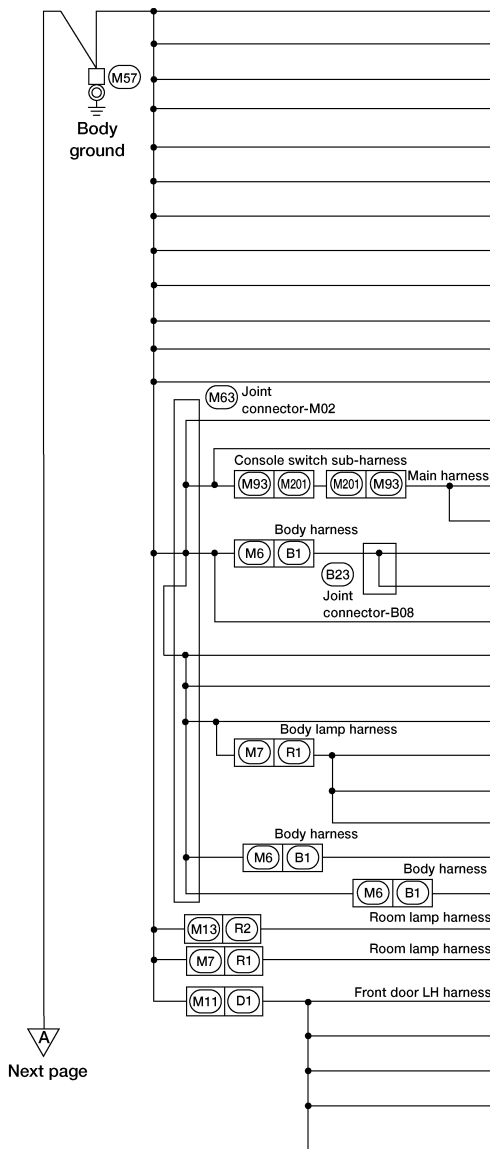
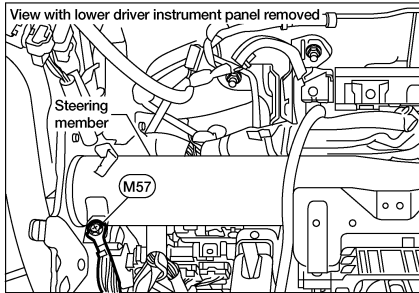

CONNECTOR NUMBER	CONNECT TO
(M5)	Fuse block (J/B)
(M17)	BCM (Body control module) (Terminal No. 13)
(M22)	Data link connector (Terminal No. 4)
(M22)	Data link connector (Terminal No. 5)
(M24)	Combination meter (Terminal No. 3)
(M24)	Combination meter (Terminal No. 4)
(M24)	Combination meter (Terminal No. 23)
(M28)	Combination switch
(M31)	Blower motor
(M40)	Key slot
(M45)	Audio unit (Terminal No. 40)
(M75)	Trunk lid opener switch
(M44)	Audio unit (Terminal No. 20)
(M45)	Audio unit (Terminal No. 27)
(M103)	AV control unit (Terminal No. 77)
(M104)	AV control unit (Terminal No. 128)
(B37)	High-mounted stop lamp (without rear spoiler)
(B37)	High-mounted stop lamp (with rear spoiler)
(B39)	Rear sonar system off switch
(M53)	Steering angle sensor
(M55)	Yaw rate/side/decel G sensor
(M100)	AV control unit (Terminal No. 20)
(R3)	Vanity mirror lamp LH
(R4)	Auto anti-dazzling inside mirror
(R9)	Vanity mirror lamp RH
(B30)	Rear combination lamp LH
(E45)	Rear combination lamp RH
(R5)	Sunroof motor assembly
(R50)	Front room/map lamp assembly
(D4)	Door mirror LH
(D5)	Door mirror remote control switch
(D6)	Front outside handle LH
(D8)	Main power window and door lock/unlock switch (Terminal No. 17)
(D10)	Front door lock assembly LH

ABMIA4560GB

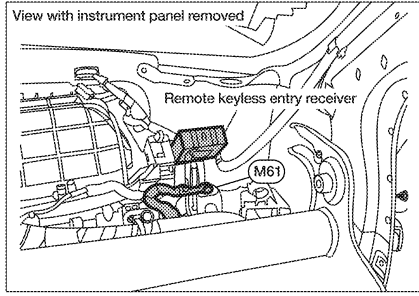

Preceding page

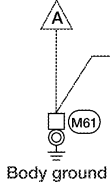

M63 Joint connector-M02

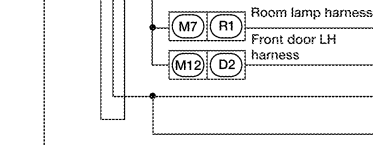

Next page

CONNECTOR NUMBER	CONNECT TO
M23	CVT shift selector (Terminal No. 4)
M23	CVT shift selector (Terminal No. 7)
M32	Electronic steering column lock (Terminal No. 5)
M32	Electronic steering column lock (Terminal No. 6)
M35	Air bag diagnosis sensor unit (Terminal No. 2)
M36	Front passenger air bag off indicator
M37	Front air control (Terminal No. 6) (without auto A/C)
M37	Front air control (Terminal No. 7) (without auto A/C)
M37	Front air control (Terminal No. 17) (with auto A/C)
M37	Front air control (Terminal No. 37) (with auto A/C)
M38	Push-button ignition switch
M39	Rear sonar system off switch (Terminal No. 6)
M40	Key slot
M54	Hazard switch (Terminal No. 1)
M30	Spiral cable
M37	Front air control (Terminal No. 8) (without auto A/C)
M37	Front air control (Terminal No. 36) (with auto A/C)
M39	Rear sonar system off switch (Terminal No. 4)
M44	Audio unit (Terminal No. 8)
M54	Hazard switch (Terminal No. 4)
M65	CVT shift selector
M72	VDC off switch (Terminal No. 4)
M72	TCS off switch (Terminal No. 4)
M80	Diode-3
M100	AV control unit (Terminal No. 8)
R50	Front room/map lamp assembly
D5	Door mirror remote control switch
M72	VDC off switch (Terminal No. 2)
M72	TCS off switch (Terminal No. 2)

ABMIA4561GB
ABMIA4561GB

A
B
C
D
E
F
G
H
I
J
K
L
M
N
O
P

PG

GROUND

Preceding page

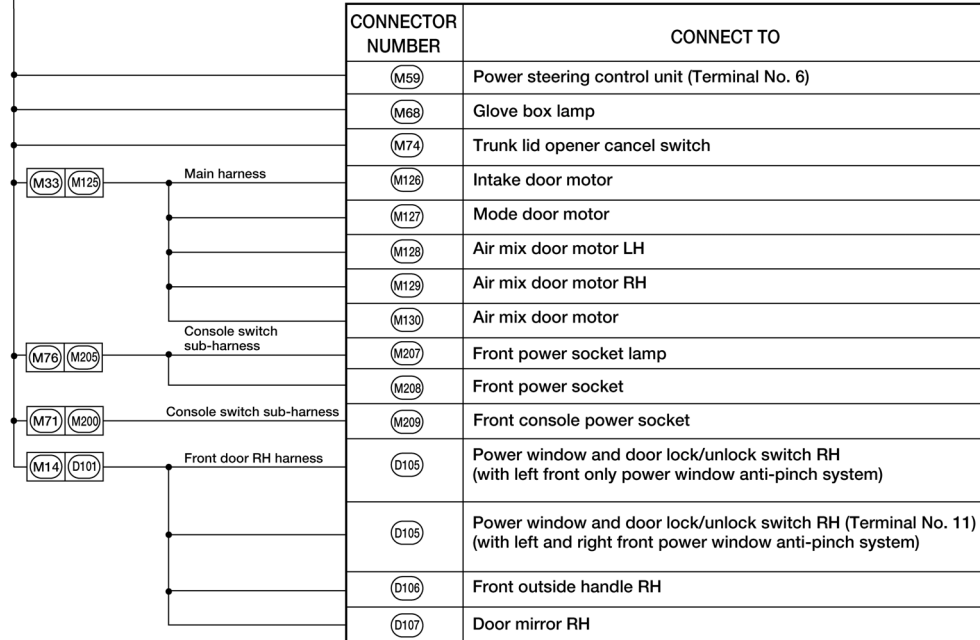

AAMIA0627GB

GROUND

< DTC/CIRCUIT DIAGNOSIS >

[SEDAN]

ENGINE ROOM HARNESS

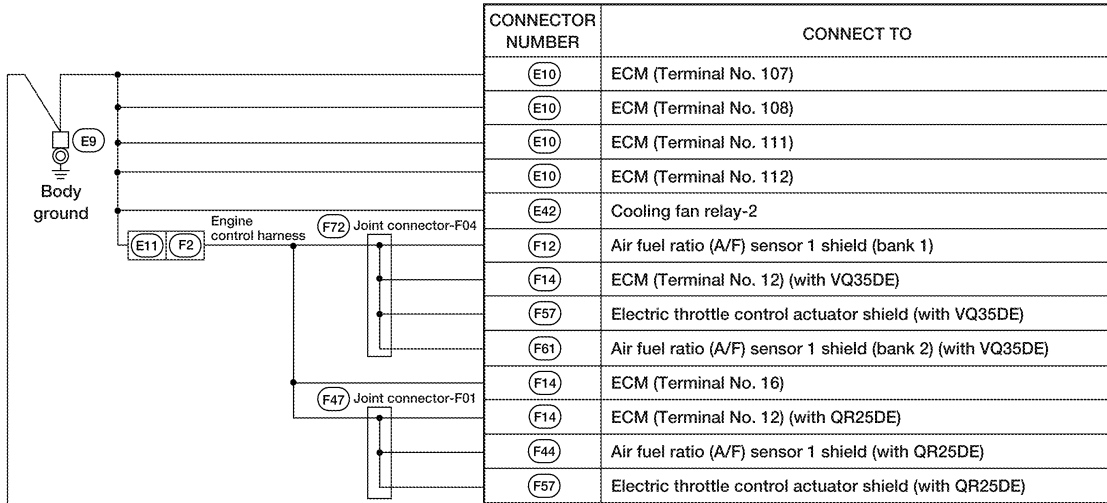
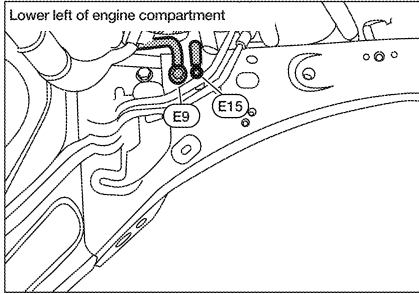

Next page

ABMIA0766GB

GROUND

< DTC/CIRCUIT DIAGNOSIS >

[SEDAN]

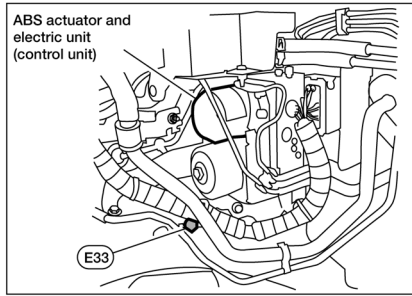
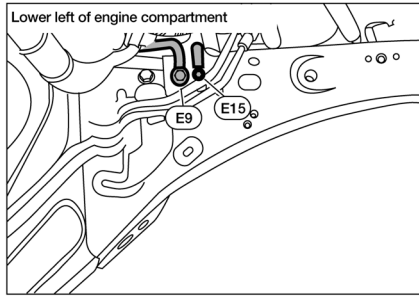

Preceding page

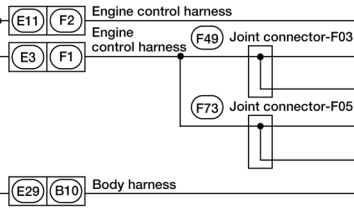

CONNECTOR NUMBER	CONNECT TO
E17	IPDM E/R (intelligent power distribution module engine room) (Terminal No. 41)
E18	IPDM E/R (intelligent power distribution module engine room) (Terminal No. 12)
E24	Brake fluid level switch
E25	Front wiper motor
E43	Cooling fan relay-3
E57	Stop lamp relay-1
E58	Stop lamp relay-2
F3	A/C compressor
F16	TCM (transmission control module) (Terminal No. 5) (with QR25DE)
F16	TCM (transmission control module) (Terminal No. 42) (with QR25DE)
F16	TCM (transmission control module) (Terminal No. 5) (with VQ35DE)
F16	TCM (transmission control module) (Terminal No. 42) (with VQ35DE)
B42	Fuel level sensor unit and fuel pump (with rear view camera)



CONNECTOR NUMBER	CONNECT TO
E26	ABS actuator and electric unit (control unit) (Terminal No. 1)
E26	ABS actuator and electric unit (control unit) (Terminal No. 4)

AAMIA0628GB

GROUND

< DTC/CIRCUIT DIAGNOSIS >

[SEDAN]

FRONT END MODULE HARNESS

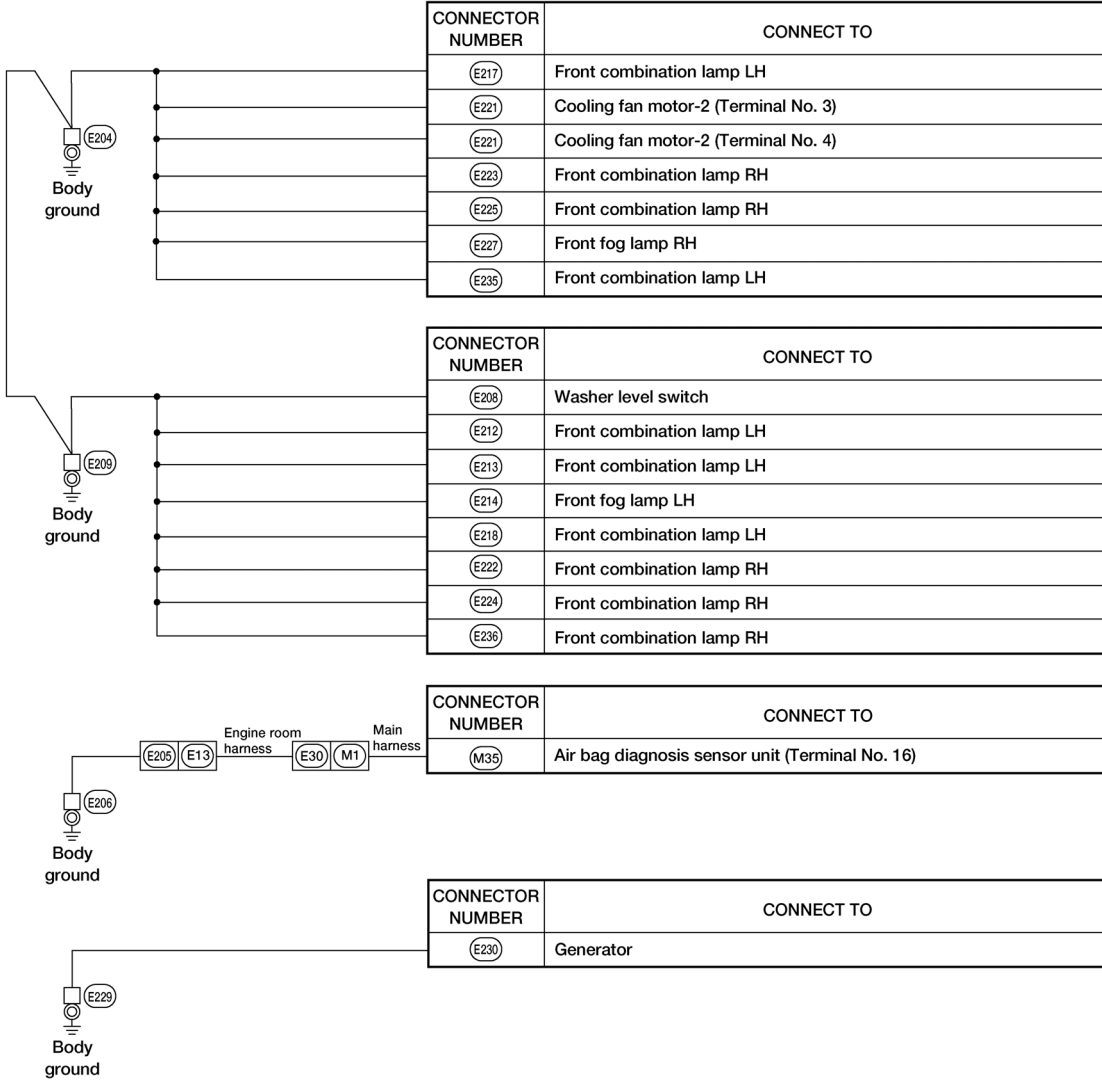
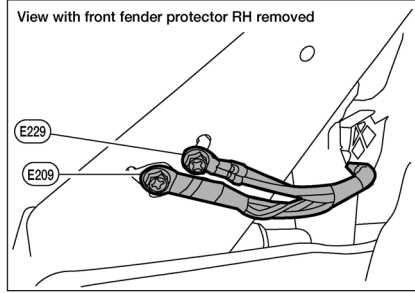
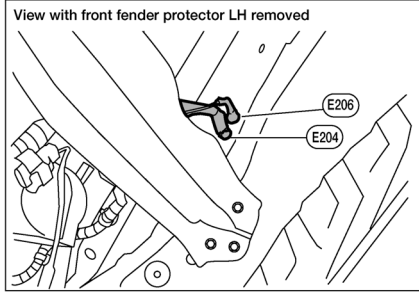

ABMIA3276GB

A
B
C
D
E
F
G
H
I
J
K
L
PG
N
O
P

GROUND

[SEDAN]

< DTC/CIRCUIT DIAGNOSIS > ENGINE CONTROL HARNESS

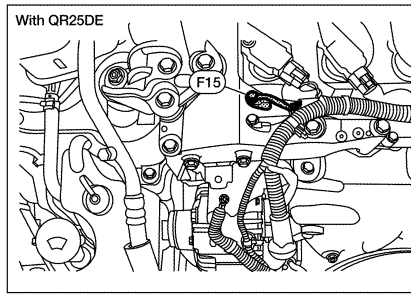
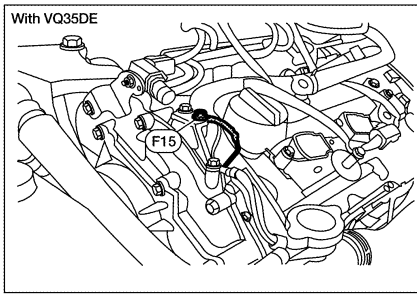

QR : With QR25DE

VQ : With VQ35DE

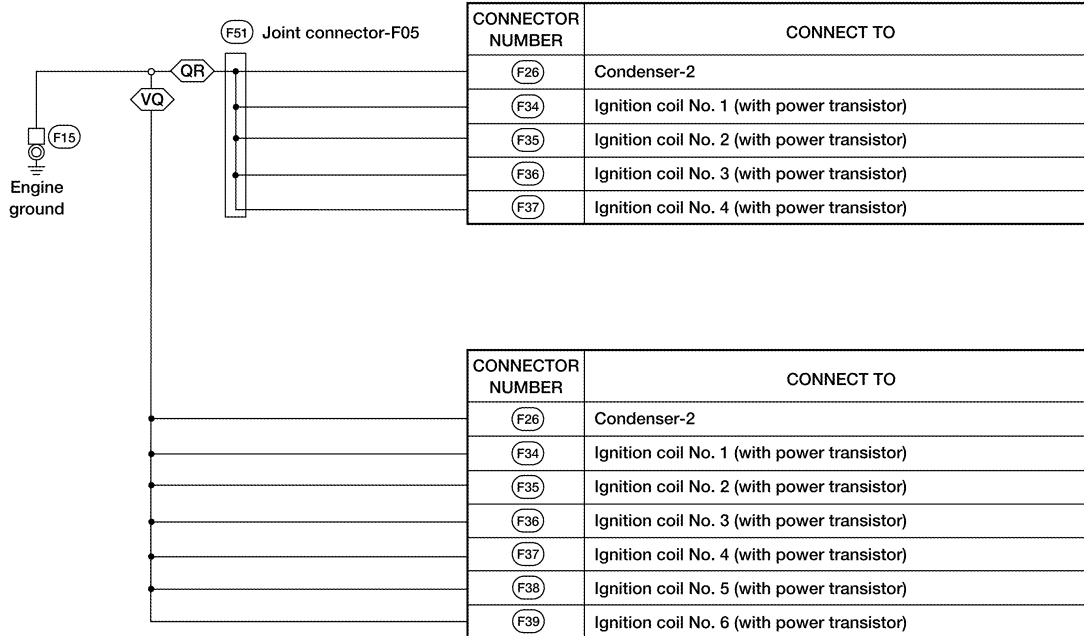

ABMIA2643GB

GROUND

< DTC/CIRCUIT DIAGNOSIS >

[SEDAN]

BODY HARNESS

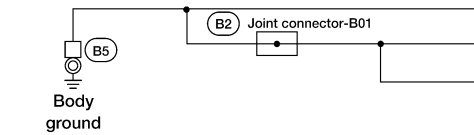
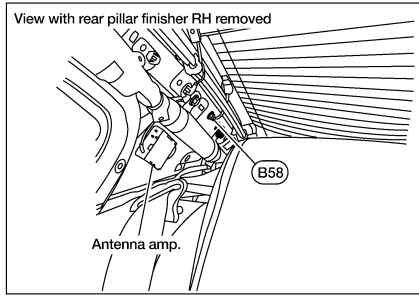
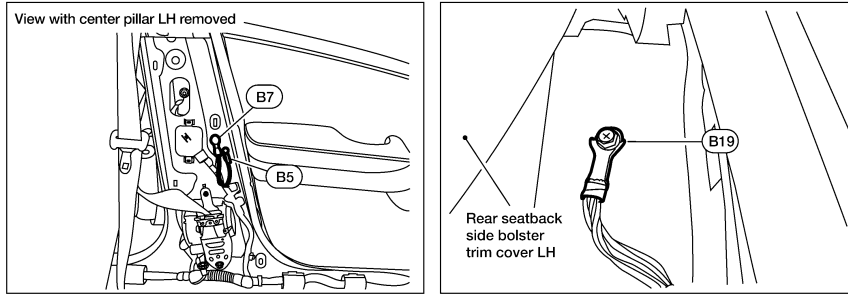

CONNECTOR NUMBER	CONNECT TO
(B15)	LH side air bag (satellite) sensor shield
(B9)	Air bag diagnosis sensor unit (Terminal No. 44)
(B38)	LH side curtain air bag module shield

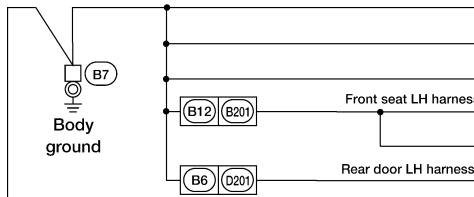

CONNECTOR NUMBER	CONNECT TO
(B28)	Trunk lamp switch and trunk release solenoid
(B32)	License plate lamp RH
(B34)	License plate lamp LH
(B203)	Power seat switch LH
(B205)	Lumbar support switch
(D203)	Rear power window switch LH

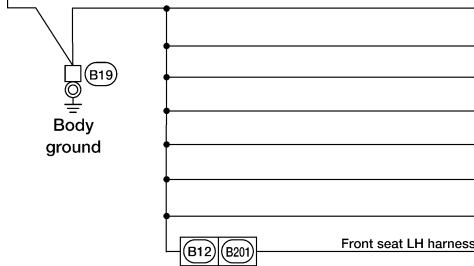

CONNECTOR NUMBER	CONNECT TO
(B42)	Fuel level sensor unit and fuel pump (without rear view camera)
(B24)	Sonar control unit
(B28)	Trunk lamp switch and trunk release solenoid
(B30)	Rear combination lamp LH (without rear view camera)
(B33)	Trunk opener request switch
(B37)	High-mounted stop lamp (without rear view camera)
(B45)	Rear combination lamp RH (without rear view camera)
(B202)	Seat belt buckle switch LH



CONNECTOR NUMBER	CONNECT TO
(B54)	Rear window defogger

AAMIA0791GB

A
B
C
D
E
F
G
H
I
J
K
L
PG
N
O
P

GROUND

[SEDAN]

< DTC/CIRCUIT DIAGNOSIS >

BODY NO. 2 HARNESS

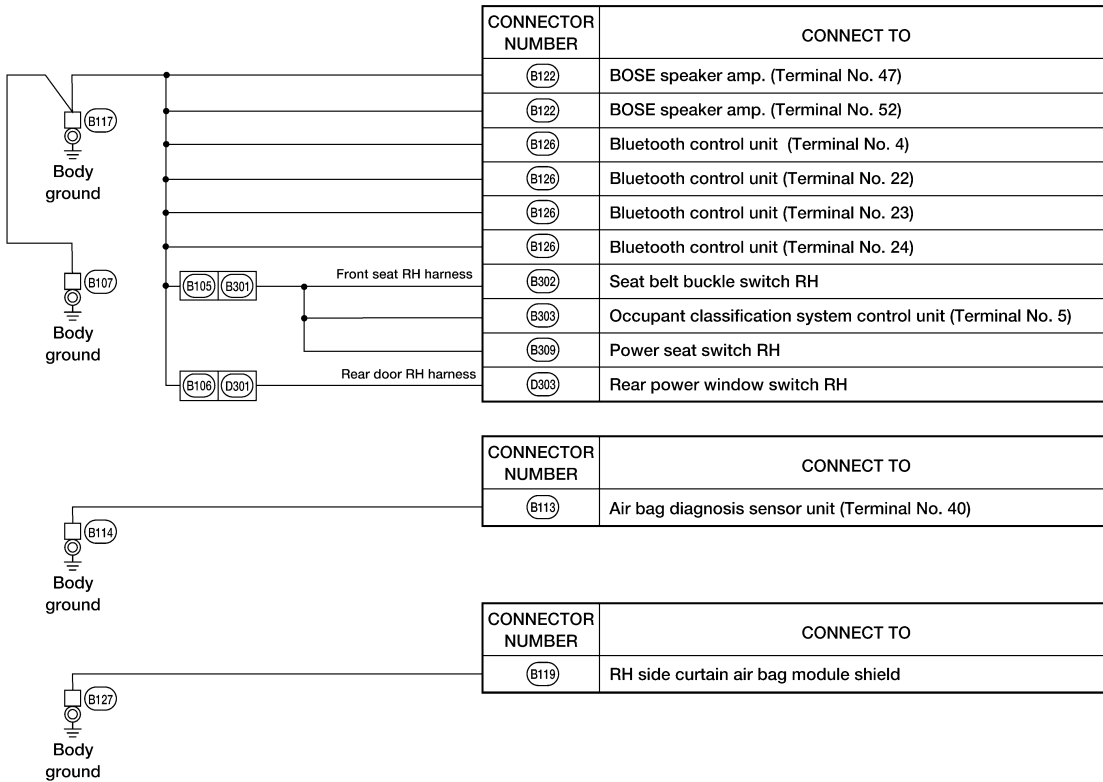
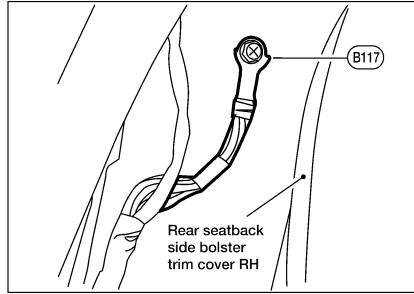
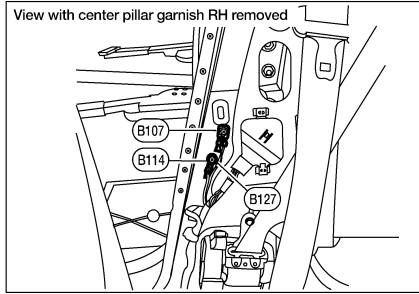

AAMIA0792GB

HARNESS

Harness Layout

INFOID:000000007419578

HOW TO READ HARNESS LAYOUT

The following Harness Layouts use a map style grid to help locate connectors on the drawings:

- Main Harness and Console Switch Sub-Harness
- Engine Room Harness
- Engine Room Harness (Passenger Compartment)
- Front End Module Harness
- Engine Control Harness (VQ35DE) and Knock Sensor Sub-harness
- Engine Control Harness (QR25DE)
- Body Harness, Rear Sonar Sub-harness and Chassis Harness
- Body No. 2 Harness
- Room Lamp Harness

To use the grid reference

1. Find the desired connector number on the connector list.
2. Find the grid reference.
3. On the drawing, find the crossing of the grid reference letter column and number row.
4. Find the connector number in the crossing zone.
5. Follow the line (if used) to the connector.

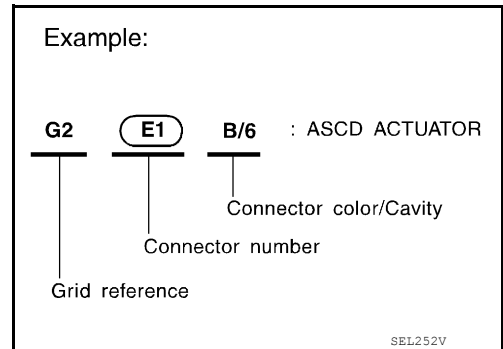

OUTLINE

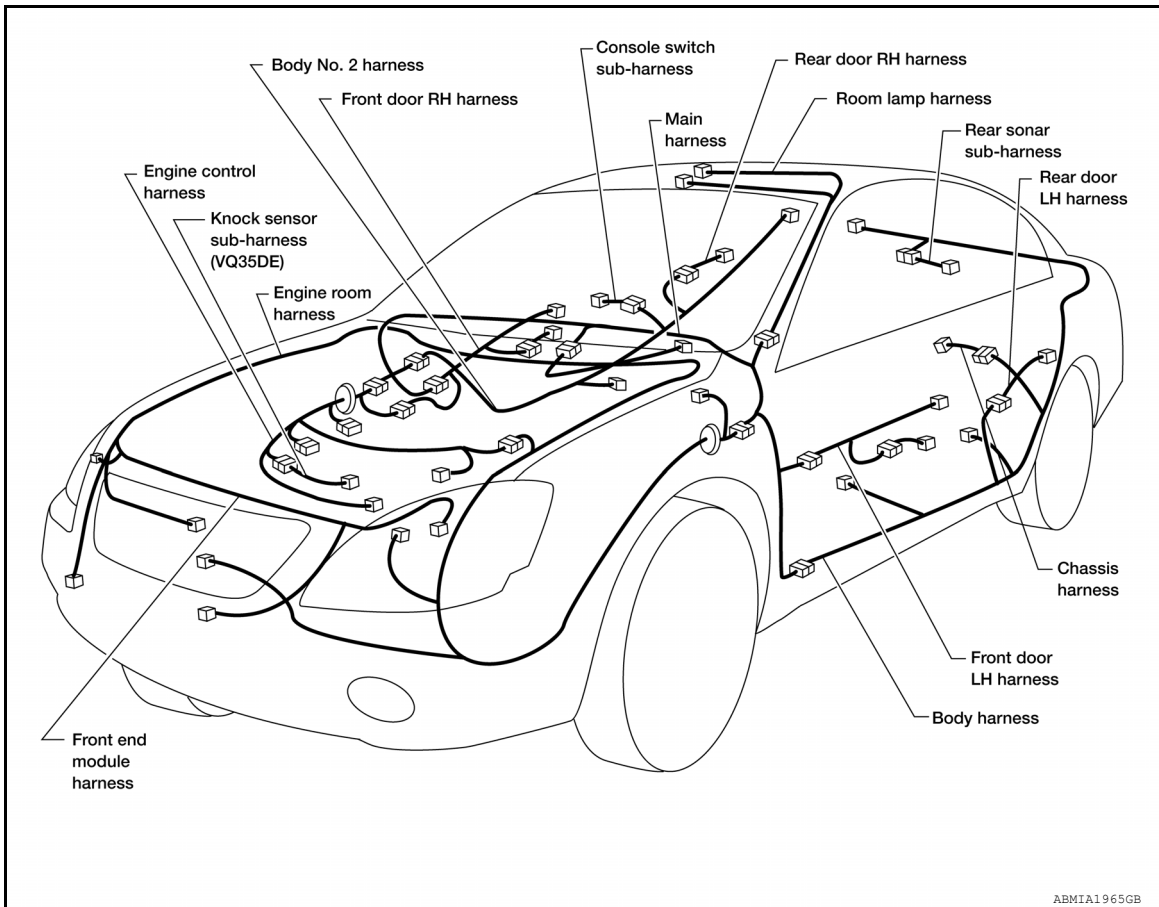

A
B
C
D
E
F
G
H
I
J
K
L
PG
N
O
P

HARNESS

< DTC/CIRCUIT DIAGNOSIS >

[SEDAN]

MAIN HARNESS

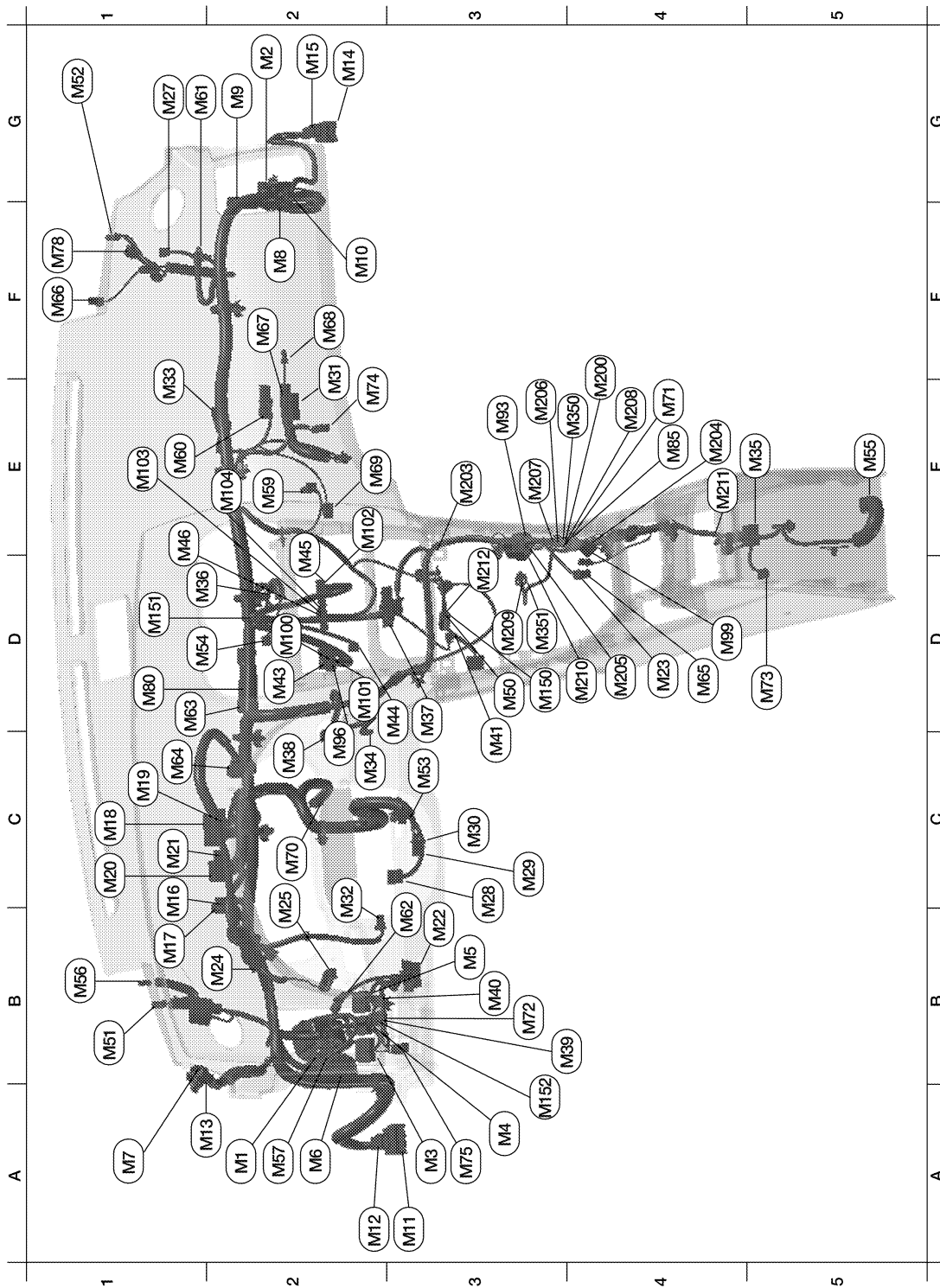

AAMIA0939GB

A2	M1	SMJ	: To E30	C3	M53	W/8	: Steering angle sensor
G2	M2	W/32	: To B101	D1	M54	W/4	: Hazard switch
A3	M3	W/8	: Fuse block (J/B)	E5	M55	B/4	: Yaw rate/side/decel G sensor
A3	M4	W/10	: Fuse block (J/B)	B1	M56	B/2	: Sunload sensor

HARNESSES

< DTC/CIRCUIT DIAGNOSIS >

[SEDAN]

B3	M5	W/12	: Fuse block (J/B)	A2	M57	—	: Body ground	A	
A2	M6	SMJ	: To B1	E2	M59	W/12	: Power steering control unit	B	
A1	M7	W/16	: To R1	E1	M60	Y/2	: Front passenger air bag module	C	
F2	M8	W/24	: To B102	G1	M61	—	: Body ground	D	
G2	M9	BR/16	: To B103	B2	M62	W/2	: Tire pressure warning check connector	E	
F2	M10	BR/12	: To B104	D1	M63	L/12	: Joint connector-M02	F	
A3	M11	W/16	: To D1	C1	M64	GR/6	: Joint connector-M01	G	
A2	M12	W/16	: To D2	D4	M65	BR/2	: CVT shift selector	H	
A1	M13	W/4	: To R2	F1	M66	W/3	: Optical sensor	I	
G2	M14	W/10	: To D101	F2	M67	O/2	: Front passenger air bag module	J	
G2	M15	W/12	: To D102	F2	M68	W/2	: Glove box lamp	K	
C1	M16	B/3	: BCM (Body control module)	E2	M69	W/4	: Intake sensor	L	
B1	M17	W/16	: BCM (Body control module)	C2	M70	W/4	: Tire pressure receiver	PG	
C1	M18	G/40	: BCM (Body control module)	E4	M71	W/12	: To M200	N	
C1	M19	B/40	: BCM (Body control module)	C3	M72	GR/6	: TCS OFF switch (with TCS)	O	
C1	M20	W/12	: BCM (Body control module)	B3	M72	GR/6	: VDC OFF switch (with VDC)	P	
C1	M21	GR/40	: BCM (Body control module)	D5	M73	B/1	: Parking brake switch (with M/T)		
B3	M22	W/16	: Data link connector	E2	M74	W/2	: Trunk lid opener cancel switch		
D4	M23	W/10	: CVT shift selector	A3	M75	B/2	: Trunk lid opener switch		
B2	M24	W/40	: Combination meter	E3	M76	W/3	: To M205		
B2	M25	B/10	: Meter mode switch	F1	M78	Y/4	: Front passenger air bag module (service replacement)		
G1	M27	B/4	: Remote keyless entry receiver	D1	M80	—	: Diode-3		
C3	M28	W/16	: Combination switch	E3	M93	W/12	: To M210		
C3	M29	Y/6	: Spiral cable	C2	M96	G/4	: Audio unit		
C3	M30	GR/8	: Spiral cable	D4	M99	GR/6	: To M204		
E2	M31	W/6	: Blower motor	D2	M100	W/20	: AV control unit		
B2	M32	W/8	: Electronic steering column lock	C2	M101	G/4	: AV control unit		
E1	M33	W/3	: To M125	E2	M102	W/32	: AV control unit		
C2	M34	W/2	: In-vehicle sensor	E1	M103	W/40	: AV control unit		
E5	M35	Y/28	: Air bag diagnosis sensor unit	E2	M104	W/28	: AV control unit		
D1	M36	W/3	: Front passenger air bag off indicator	D3	M150	W/2	: To M50		
D3	M37	W/40	: Front air control (with auto A/C)	D1	M151	BR/2	: Center speaker		
D3	M37	W/16	: Front air control (without auto A/C)	A3	M152	L/4	: Accessory relay-2 (late production)		
C2	M38	BR/8	: Push-button ignition switch	Console switch sub-harness					
B4	M39	GR/8	: Rear sonar system OFF switch	D3	M200	W/12	: To M71		
B3	M40	W/12	: Key slot	E3	M203	GR/2	: Front console antenna		
D3	M41	W/2	: Sonar buzzer	E4	M204	GR/6	: To M99		
D2	M43	W/20	: Audio unit	D4	M205	B/2	: To M76		
D3	M44	W/8	: Audio unit (with base audio system)	E3	M206	B/2	: Front power socket lamp		
D2	M44	W/20	: Audio unit (with BOSE audio system) (without NAVI)	E3	M207	B/1	: Front power socket lamp (for cigarette lighter)		
E2	M45	W/32	: Audio unit	E4	M208	B/3	: Front power socket		
E1	M46	W/12	: Audio unit	D3	M209	B/3	: Front console power socket		
D3	M50	W/2	: To M150	D3	M210	W/12	: To M93		

HARNESS

[SEDAN]

< DTC/CIRCUIT DIAGNOSIS >

B1	M51	BR/2	: Tweeter LH	D3	M211	G/4	: USB interface
G1	M52	BR/2	: Tweeter RH	D3	M212	W/8	: Aux jack

ENGINE ROOM HARNESS

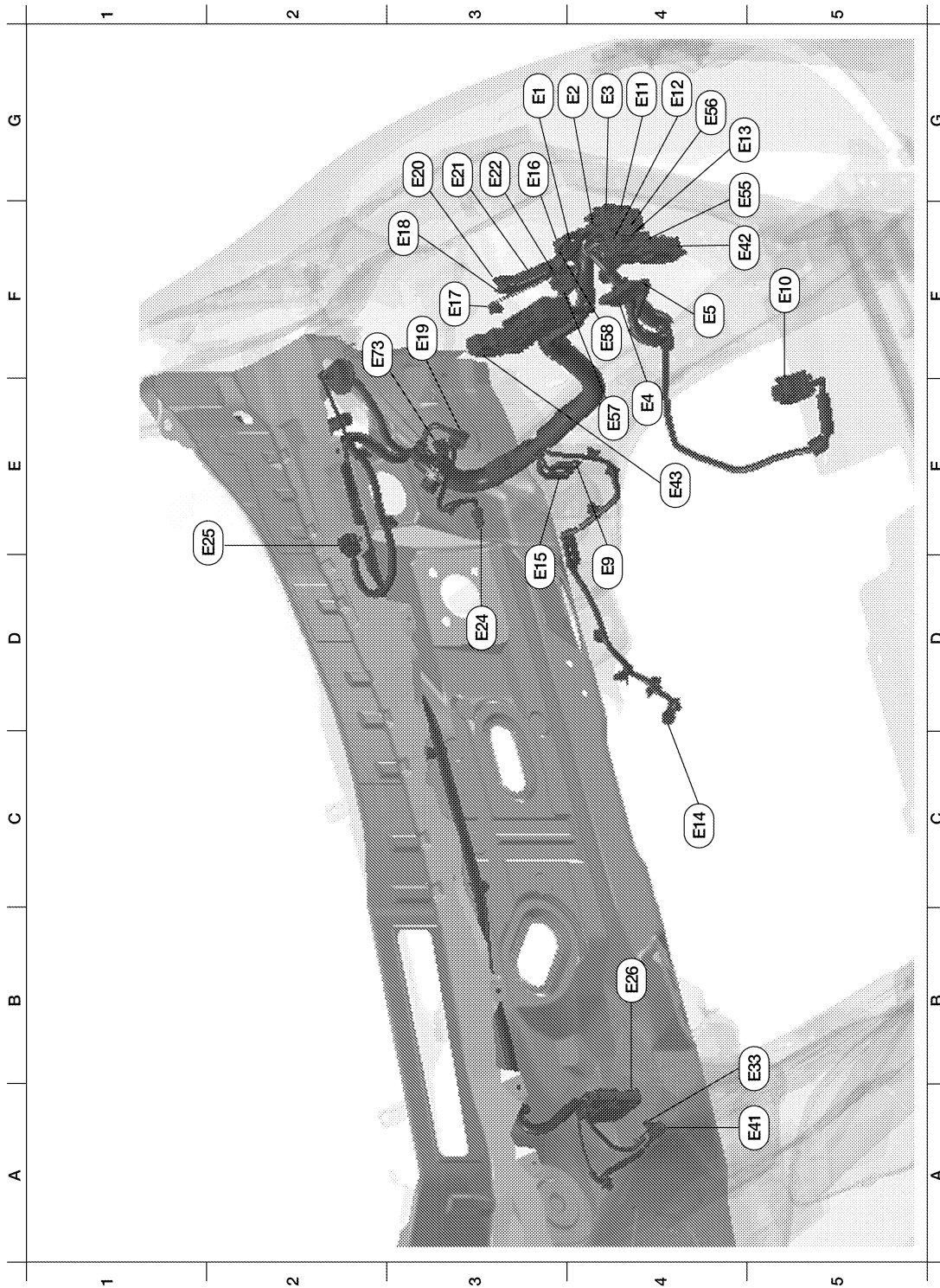

ABMIA3278GB

G3	E1	W/6	: Joint connector-E01	G3	E20	W/6	: Joint connector-E02
G3	E2	W/8	: To E202	G3	E21	W/4	: Joint connector-E03
G4	E3	W/16	: To F1	G3	E22	W/4	: Joint connector-E04

HARNESSES

< DTC/CIRCUIT DIAGNOSIS >

[SEDAN]

F4	E4	BR/2	: Fusible link box (battery)	D3	E24	GR/2	: Brake fluid level switch
F4	E5	GR/2	: Fusible link box (battery)	E1	E25	GR/5	: Front wiper motor
E3	E9	—	: Body ground	B4	E26	B/26	: ABS actuator and electric unit (control unit)
F5	E10	B/32	: ECM	B5	E33	—	: Body ground
G4	E11	W/10	: To F2	A5	E41	GR/2	: Front wheel sensor RH
G4	E12	W/6	: To E203	F5	E42	BR/6	: Cooling fan relay-2
G4	E13	B/3	: To E205	E4	E43	BR/6	: Cooling fan relay-3
C4	E14	B/2	: Power steering solenoid valve	G5	E55	W/4	: Joint connector-E07
D3	E15	—	: Body ground	G4	E56	W/4	: Joint connector-E14
G5	E16	B/2	: IPDM E/R (Intelligent power distribution module engine room)	E4	E57	L/4	: Stop lamp relay-1
F3	E17	W/8	: IPDM E/R (Intelligent power distribution module engine room)	F4	E58	L/4	: Stop lamp relay-2
F3	E18	W/36	: IPDM E/R (Intelligent power distribution module engine room)	E3	E73	BR/3	: Intelligent Key warning buzzer
F3	E19	GR/2	: Front wheel sensor LH				

A
B
C
D
E
F
G
H
I
J
K
L

PG

N
O
P

HARNESS

< DTC/CIRCUIT DIAGNOSIS >

[SEDAN]

ENGINE ROOM HARNESS (PASSENGER COMPARTMENT)

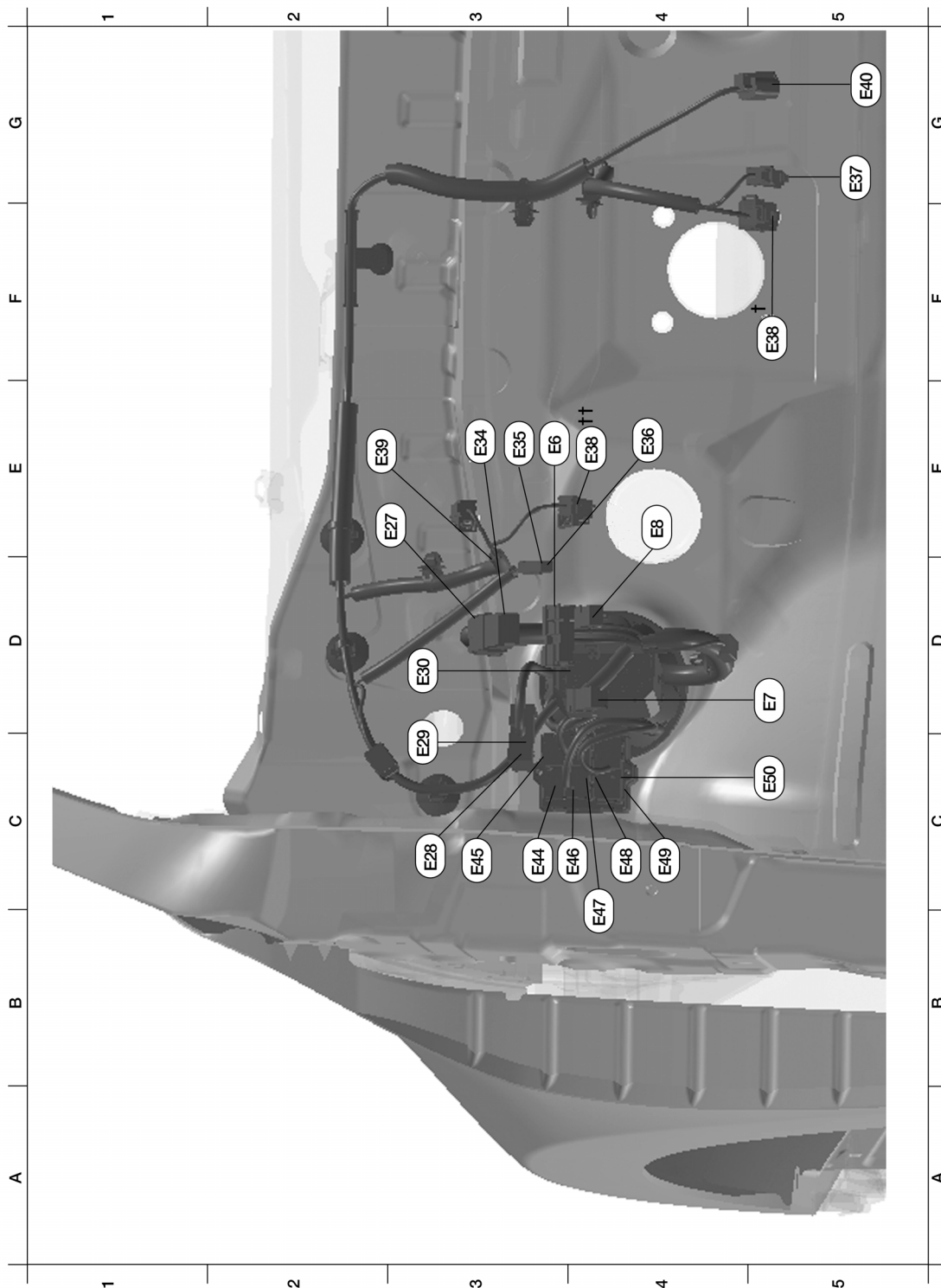

ABMIA1967GB

E3	E6	W/16	: Fuse block (J/B)	F5	E38†	W/4	: Stop lamp switch (with CVT)
D5	E7	W/1	: Fuse block (J/B)	E4	E38††	B/2	: Stop lamp switch (with M/T)
E4	E8	B/2	: Fuse block (J/B)	E2	E39	BR/2	: ASCD clutch switch
E3	E27	W/4	: Joint connector-E06	G5	E40	B/6	: Accelerator pedal position (APP) sensor
C3	E28	W/4	: Joint connector-E05	C3	E44	BR/12	: Junction block

HARNESS

< DTC/CIRCUIT DIAGNOSIS >

[SEDAN]

C3	E29	W/16	: To B10	C3	E45	W/12	: Junction block
D3	E30	SMJ	: To M1	C4	E46	W/16	: Junction block
E3	E34	L/4	: Back-up lamp relay	C4	E47	W/6	: Junction block
E3	E35	B/1	: Parking brake switch (with CVT)	C4	E48	W/4	: Junction block
E4	E36	BR/2	: Clutch interlock switch	C4	E49	BR/4	: Junction block
G5	E37	BR/2	: ASCD brake switch	C5	E50	W/2	: Junction block

A

B

C

D

E

F

G

H

I

J

K

L

PG

N

O

P

HARNESS

< DTC/CIRCUIT DIAGNOSIS >

[SEDAN]

FRONT END MODULE HARNESS

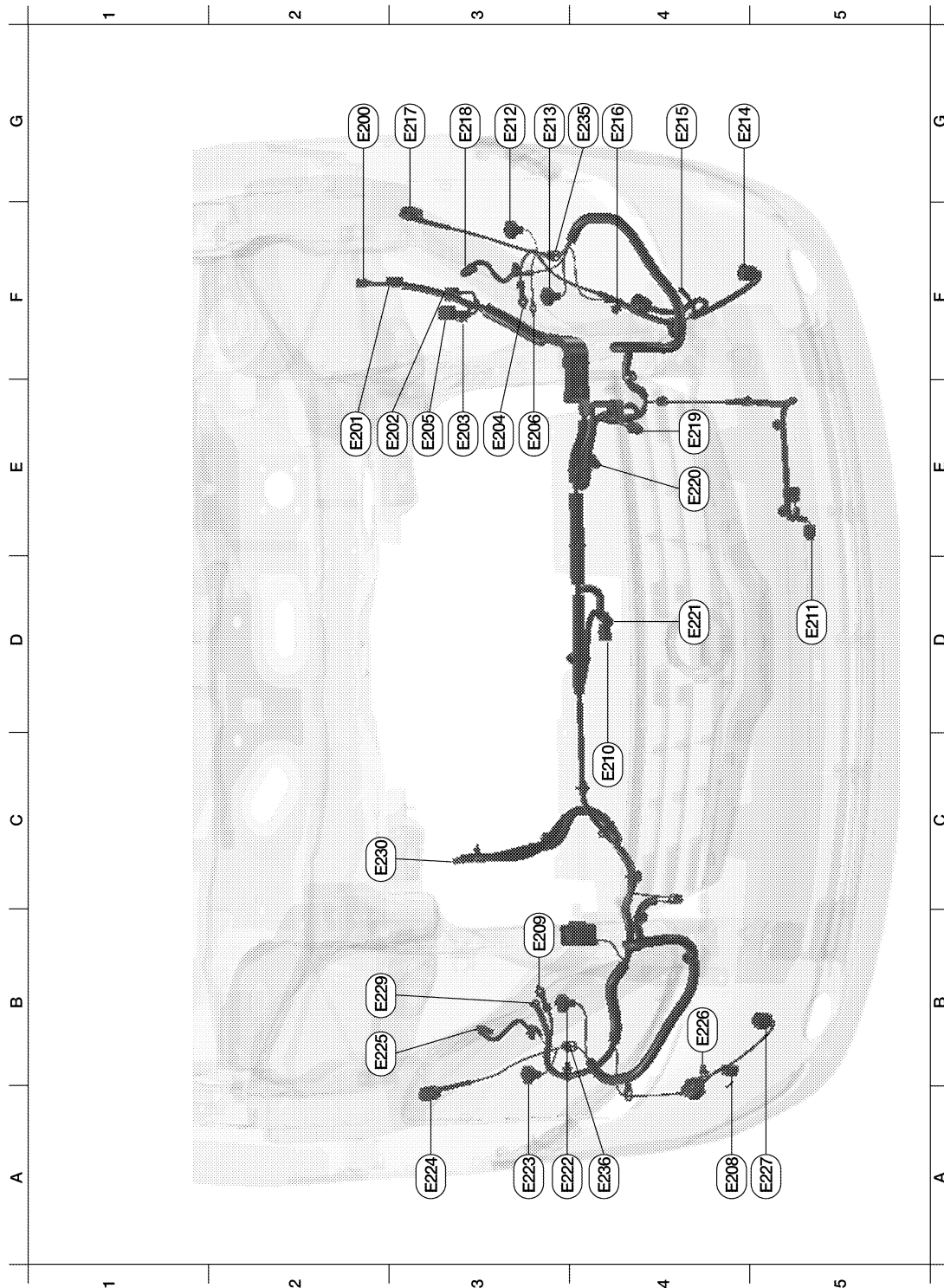

ABMIA3279GB

G2	E200	W/8	: IPDM E/R (Intelligent power distribution module engine room)	G3	E217	GR/3	: Front combination lamp LH
E2	E201	W/16	: IPDM E/R (Intelligent power distribution module engine room)	G3	E218	B/2	: Front combination lamp LH
E3	E202	W/8	: To E2	E4	E219	B/3	: Refrigerant pressure sensor
E3	E203	W/6	: To E12	E4	E220	GR/4	: Cooling fan motor-1

HARNESS

< DTC/CIRCUIT DIAGNOSIS >

[SEDAN]

E3	E204	—	: Body ground	D4	E221	GR/4	: Cooling fan motor-2
E3	E205	B/3	: To E13	A3	E222	B/2	: Front combination lamp RH
E3	E206	—	: Body ground	A3	E223	B/2	: Front combination lamp RH (halogen)
A4	E208	W/2	: Washer fluid level switch	A3	E223	GR/2	: Front combination lamp RH (xenon)
B3	E209	—	: Body ground	A3	E224	GR/3	: Front combination lamp RH
C4	E210	Y/2	: Crash zone sensor	B3	E225	B/2	: Front combination lamp RH
D4	E211	B/2	: Ambient sensor	B4	E226	B/2	: Front washer motor
G3	E212	B/2	: Front combination lamp LH (halogen)	B5	E227	B/2	: Front fog lamp RH
G3	E212	GR/2	: Front combination lamp LH (xenon)	B3	E229	—	: Body ground
G3	E213	B/2	: Front combination lamp LH	C2	E230	—	: Generator
G4	E214	B/2	: Front fog lamp LH	G4	E235	B/2	: Front combination lamp LH
G4	E215	B/1	: Horn (low)	A4	E236	B/2	: Front combination lamp RH
G4	E216	B/1	: Horn (high)				

A
B
C
D
E
F
G
H
I
J
K
L

PG

N
O
P

HARNESS

[SEDAN]

< DTC/CIRCUIT DIAGNOSIS >

ENGINE CONTROL HARNESS (VQ35DE)

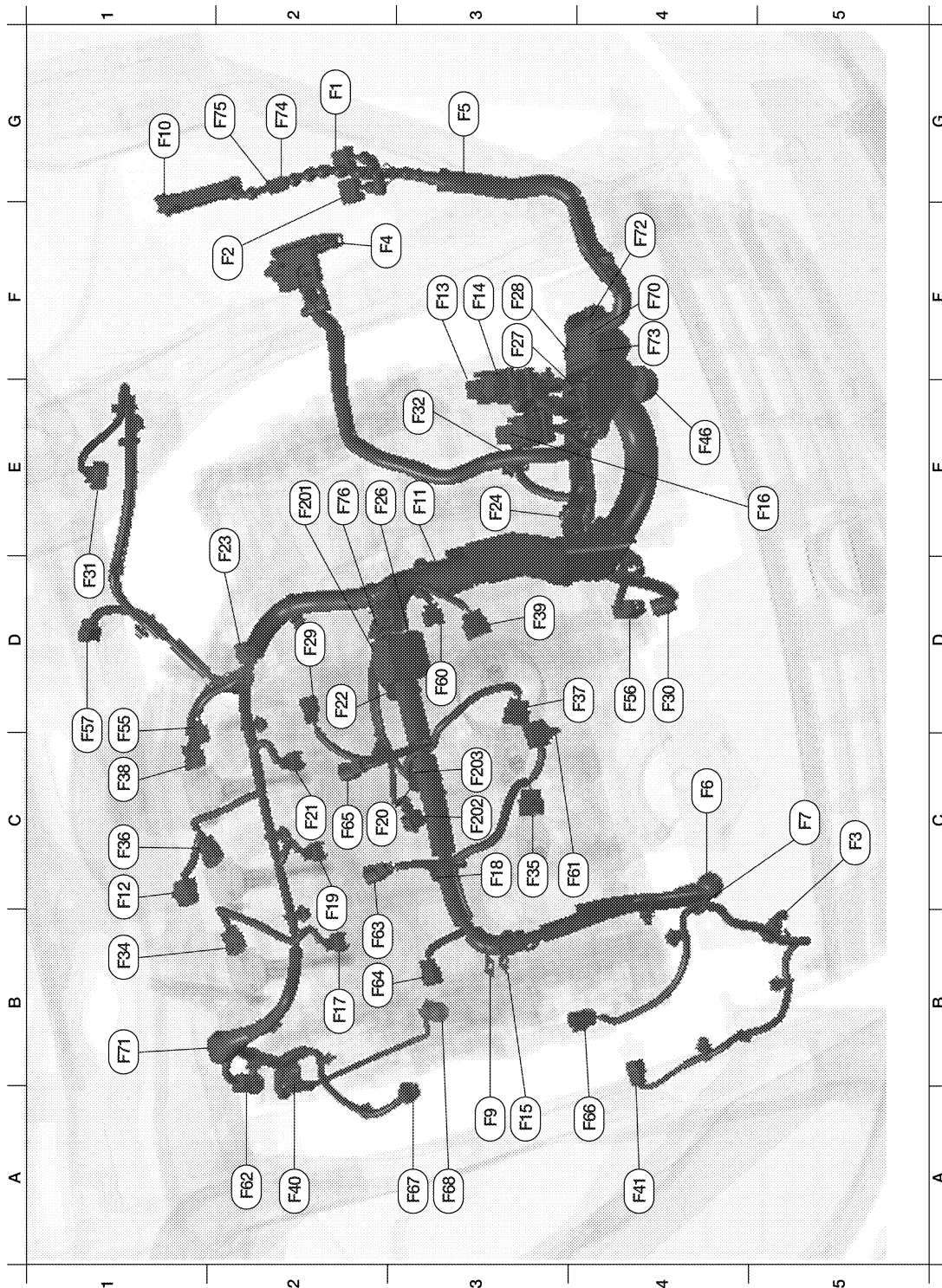

ABMIA0776GB

G2	F1	W/16	: To E3	C3	F35	GR/3	: Ignition coil No. 2 (with power transistor)
F1	F2	W/10	: To E11	C1	F36	GR/3	: Ignition coil No. 3 (with power transistor)
C5	F3	B/2	: A/C Compressor	D3	F37	GR/3	: Ignition coil No. 4 (with power transistor)
F2	F4	—	: Fusible link box (battery)	C1	F38	GR/3	: Ignition coil No. 5 (with power transistor)
G3	F5	B/3	: Battery current sensor	D3	F39	GR/3	: Ignition coil No. 6 (with power transistor)

HARNESSES

< DTC/CIRCUIT DIAGNOSIS >

[SEDAN]

C4	F6	—	: Generator	A2	F40	B/3	: Power steering pressure sensor	A	
C5	F7	B/3	: Generator	A4	F41	GR/1	: Oil pressure switch		
A3	F9	—	: Engine ground	E4	F46	B/22	: CVT unit		
G1	F10	W/36	: IPDM E/R (Intelligent power distribution module engine room)	D1	F55	B/3	: Camshaft position sensor (PHASE) (bank 1)	B	
E3	F11	GR/2	: Engine coolant temperature sensor	D4	F56	B/4	: Heated oxygen sensor 2 (bank 2)		
C1	F12	GR/4	: Air fuel ratio (A/F) sensor 1 (bank 1)	D1	F57	B/6	: Electric throttle control actuator	C	
F3	F13	BR/48	: ECM	D3	F60	B/3	: Camshaft position sensor (PHASE) (bank 2)		
F3	F14	GR/32	: ECM	C3	F61	GR/4	: Air fuel ratio (A/F) sensor 1 (bank 2)	D	
A3	F15	—	: Engine ground	A2	F62	B/4	: Heated oxygen sensor 2 (bank 1)	E	
E4	F16	B/48	: TCM (Transmission control module)	B2	F63	B/2	: VIAS control solenoid valve 1		
B2	F17	GR/2	: Fuel injector No. 1	B2	F64	BR/2	: Electronic controlled engine mount control solenoid valve	F	
C3	F18	GR/2	: Fuel injector No. 2	C2	F65	B/2	: VIAS control solenoid valve 2		
B2	F19	GR/2	: Fuel injector No. 3	A3	F66	GR/2	: Intake valve timing control solenoid valve (bank 2)	G	
C2	F20	GR/2	: Fuel injector No. 4	A3	F67	GR/2	: Intake valve timing control solenoid valve (bank 1)	H	
C2	F21	GR/2	: Fuel injector No. 5	A3	F68	GR/2	: Engine oil temperature sensor		
D2	F22	GR/2	: Fuel injector No. 6	F4	F70	B/10	: Joint connector-F01	I	
E1	F23	B/3	: Secondary speed sensor	B1	F71	G/6	: Joint connector-F03	J	
E3	F24	B/2	: Back-up lamp switch	F4	F72	B/10	: Joint connector-F04		
E2	F26	W/2	: Condenser-2	F4	F73	B/10	: Joint connector-F05	K	
F3	F27	—	: Starter motor	G2	F74	W/4	: Joint connector-F08		
F3	F28	GR/1	: Starter motor	G1	F75	W/4	: Joint connector-F07	L	
D2	F29	L/2	: EVAP canister purge volume control solenoid valve	E2	F76	L/4	: To F201		
D4	F30	B/3	: Crankshaft position sensor (POS)	Knock sensor sub-harness					
D1	F31	B/6	: Mass air flow sensor	E2	F201	L/4	: To F76		
E3	F32	B/2	: Park/neutral position (PNP) switch (with M/T)	C3	F202	GR/2	: Knock sensor (bank 1)		
B1	F34	GR/3	: Ignition coil No. 1 (with power transistor)	C3	F203	GR/2	: Knock sensor (bank 2)		

PG

N

O

P

HARNESS

< DTC/CIRCUIT DIAGNOSIS >

[SEDAN]

ENGINE CONTROL HARNESS (QR25DE)

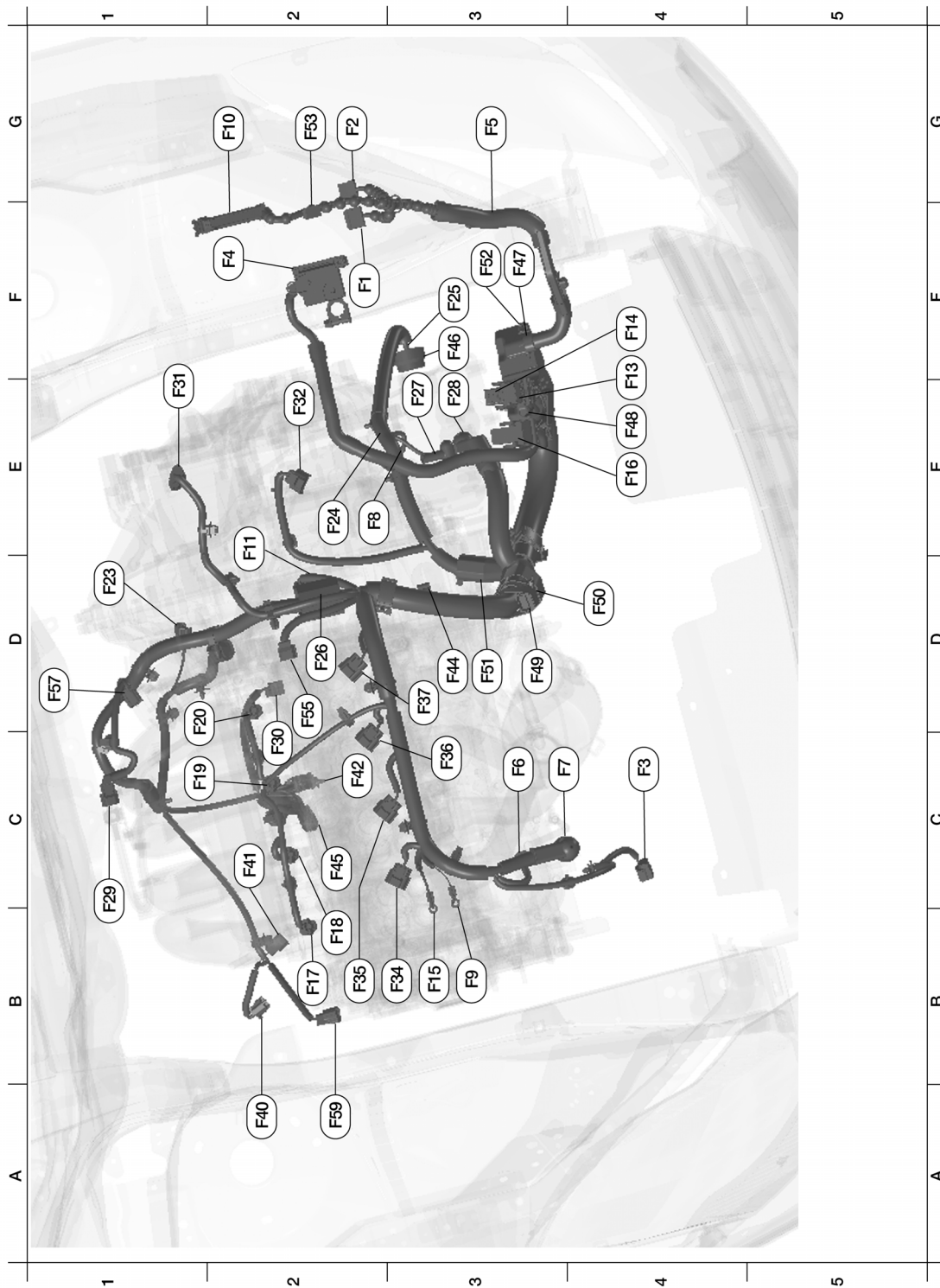

ABMIA1969GB

F2	F1	W/16	: To E3	C1	F29	L/2	: EVAP canister purge volume control solenoid valve
G2	F2	W/10	: To E11	D2	F30	B/3	: Crankshaft position sensor (POS)
C4	F3	B/2	: A/C Compressor	E1	F31	B/6	: Mass air flow sensor
F2	F4	—	: Fusible link box (battery)	E2	F32	B/2	: Park/neutral position (PNP) switch (with M/T)
G3	F5	B/3	: Battery current sensor	B3	F34	GR/3	: Ignition coil No. 1 (with power transistor)

HARNESSES

< DTC/CIRCUIT DIAGNOSIS >

[SEDAN]

C3	F6	—	: Generator	B2	F35	GR/3	: Ignition coil No. 2 (with power transistor)	A
C3	F7	B/3	: Generator	C3	F36	GR/3	: Ignition coil No. 3 (with power transistor)	
E2	F8	W/3	: Primary speed sensor	D3	F37	GR/3	: Ignition coil No. 4 (with power transistor)	
B3	F9	—	: Engine ground	A2	F40	B/3	: Power steering pressure sensor	B
G2	F10	W/36	: IPDM E/R (Intelligent power distribution module engine room)	C2	F41	GR/1	: Oil pressure switch	
E2	F11	GR/2	: Engine coolant temperature sensor	C2	F42	B/4	: Heated oxygen sensor 2	C
F4	F13	BR/48	: ECM	D3	F44	GR/4	: Air fuel ratio (A/F) sensor 1	
F4	F14	GR/32	: ECM	C2	F45	GR/2	: Knock sensor	D
B3	F15	—	: Engine ground	F3	F46	B/22	: CVT unit	
E4	F16	B/48	: TCM (Transmission control module)	F3	F47	B/6	: Joint connector-F01	E
B2	F17	GR/2	: Fuel injector No. 1	E4	F48	B/6	: Joint connector-F02	
B2	F18	GR/2	: Fuel injector No. 2	D3	F49	B/10	: Joint connector-F03	F
C1	F19	GR/2	: Fuel injector No. 3	D4	F50	B/10	: Joint connector-F04	
D1	F20	GR/2	: Fuel injector No. 4	D3	F51	B/6	: Joint connector-F05	G
D1	F23	B/3	: Secondary speed sensor	F3	F52	B/10	: Joint connector-F06	
E2	F24	B/2	: Back-up lamp switch	G2	F53	B/4	: Joint connector-F07	H
F3	F25	B/10	: Transmission range switch	D2	F55	B/3	: Camshaft position sensor (PHASE)	
D2	F26	W/2	: Condenser-2	D1	F57	B/6	: Electric throttle control actuator	I
F3	F27	—	: Starter motor	A2	F59	GR/2	: Intake valve timing control solenoid valve	J
F3	F28	—	: Starter motor					K

PG

N

O

P

HARNESS

< DTC/CIRCUIT DIAGNOSIS >

[SEDAN]

BODY HARNESS

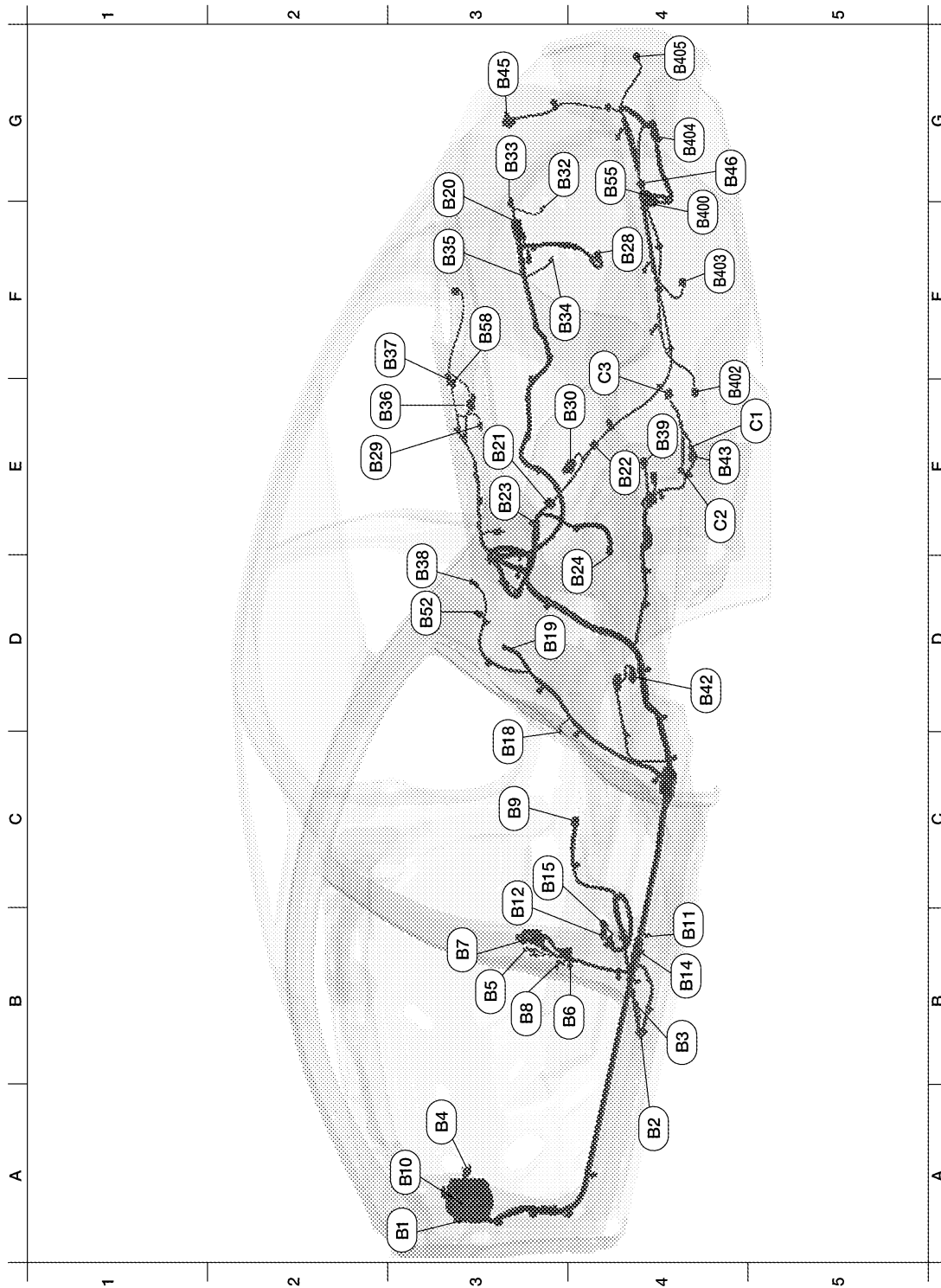

AAMIA0631GB

A3	B1	SMJ	: To M6	G3	B33	BR/2	: Trunk opener request switch
A4	B2	W/4	: Joint connector-B01	G4	B34	BR/2	: License plate lamp LH
B4	B3	W/4	: Joint connector-B02	F3	B35	W/4	: Rear view camera
A3	B4	BR/12	: Fuse block (J/B)	E3	B36	W/2	: Trunk room lamp
B3	B5	—	: Body ground	E3	B37	W/2	: High-mounted stop lamp (without rear spoiler)

HARNESSES

< DTC/CIRCUIT DIAGNOSIS >

[SEDAN]

B4	B6	W/8	: To D201	E3	B37	BR/2	: High-mounted stop lamp (with rear spoiler)	A
B3	B7	—	: Body ground	D3	B38	Y/2	: LH side curtain air bag module	
B3	B8	W/3	: Front door switch LH	E4	B39	B/2	: EVAP canister vent control valve	
C3	B9	Y/12	: Air bag diagnosis sensor unit	D4	B42	GR/5	: Fuel level sensor unit and fuel pump	B
A3	B10	W/16	: To E29	E4	B43	GR/4	: To C1	C
B4	B11	Y/2	: Front LH side air bag module	G3	B45	W/6	: Rear combination lamp RH	
B3	B12	W/8	: To B201	G4	B46	GR/2	: Rear bumper antenna	
B4	B14	Y/2	: Front LH seat belt pre-tensioner	D3	B52	W/1	: Condenser	D
C3	B15	Y/2	: LH side air bag (satellite) sensor	G4	B55	B/10	: To B400	
C3	B18	W/3	: Rear door switch LH	F3	B58	—	: Body ground	
D3	B19	—	: Body ground	Rear sonar sub-harness				E
G3	B20	GR/6	: Joint connector-B05	F4	B400	B/10	: To B55	
E3	B21	L/12	: Joint connector-B06	E4	B402	B/3	: Rear sonar sensor LH outer	
E4	B22	GR/6	: Joint connector-B07	F4	B403	B/3	: Rear sonar sensor LH inner	F
E3	B23	W/4	: Joint connector-B08	G4	B404	B/3	: Rear sonar sensor RH inner	G
D4	B24	W/16	: Sonar control unit	G4	B405	B/3	: Rear sonar sensor RH outer	
F4	B28	W/4	: Trunk lamp switch and trunk release solenoid	Chassis harness				
E2	B29	GR/2	: Rear parcel shelf antenna	E5	C1	GR/4	: To B43	H
E4	B30	W/6	: Rear combination lamp LH	E4	C2	GR/2	: Rear wheel sensor LH	I
F4	B32	BR/2	: License plate lamp RH	F4	C3	B/2	: Rear wheel sensor RH	

PG

N

O

P

HARNESS

< DTC/CIRCUIT DIAGNOSIS >

[SEDAN]

BODY NO. 2 HARNESS

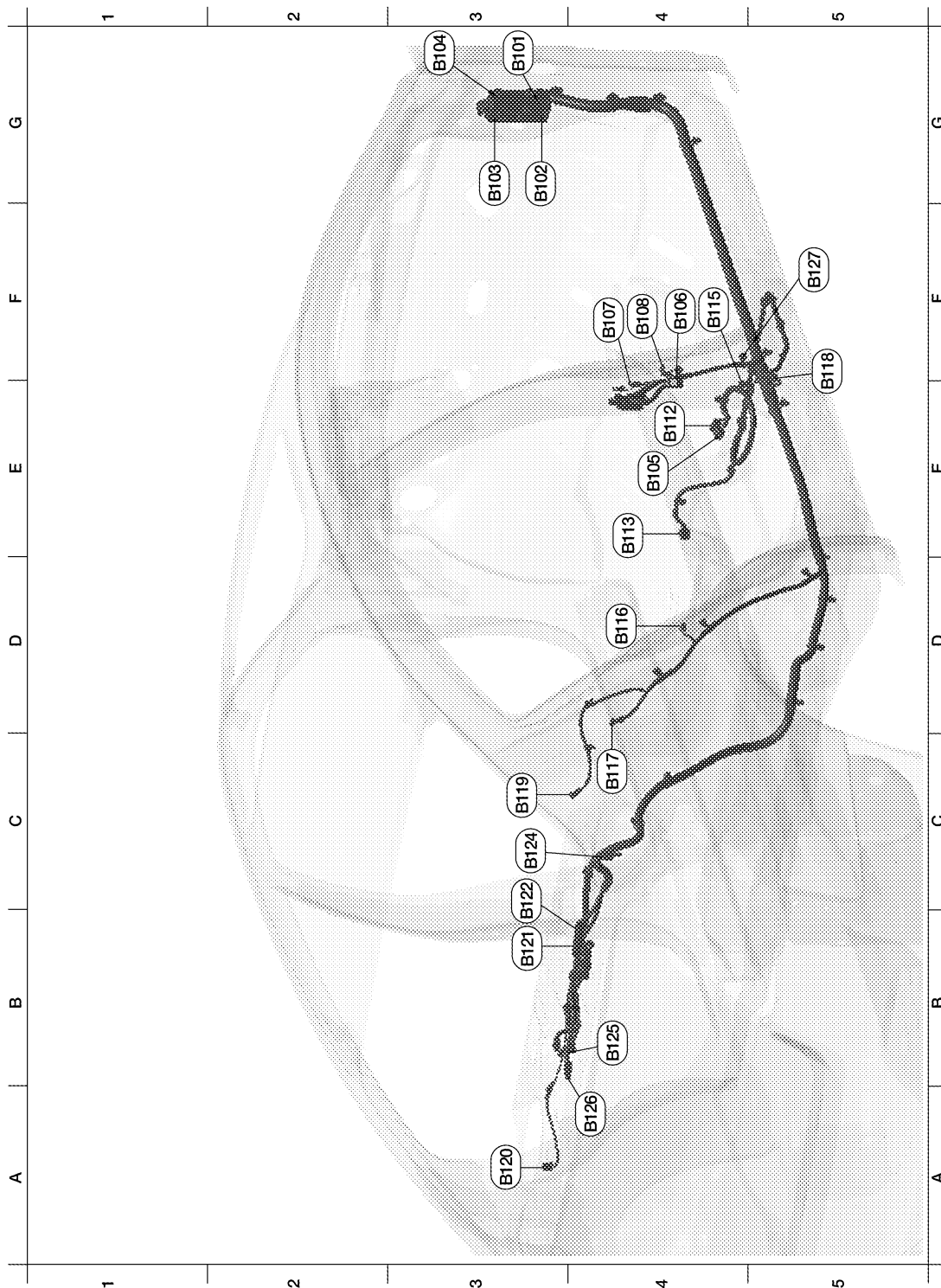

AAMIA0632GB

G3	B101	W/32	: To M2	D4	B116	W/3	: Rear door switch RH
G3	B102	W/24	: To M8	C4	B117	—	: Body ground
G3	B103	BR/16	: To M9	F5	B118	Y/2	: RH side air bag (satellite) sensor
G3	B104	BR/12	: To M10	C3	B119	Y/2	: RH side curtain air bag module
E4	B105	W/8	: To B301 (without power seat for passenger side)	A3	B120	W/2	: Rear subwoofer LH

HARNESSES

< DTC/CIRCUIT DIAGNOSIS >

[SEDAN]

E4	B105	B/10	: To B301 (with power seat for passenger side)	B3	B121	BR/23	: BOSE speaker amp.	A
F4	B106	W/8	: To D301	B3	B122	BR/14	: BOSE speaker amp.	
F4	B107	—	: Body ground	C3	B124	W/2	: Rear subwoofer RH	B
F4	B108	W/3	: Front door switch RH	B4	B125	W/8	: Bluetooth control unit	
E4	B112	Y/2	: Front RH side air bag module	A4	B126	W/32	: Bluetooth control unit	
E4	B113	Y/12	: Air bag diagnosis sensor unit	F5	B127	—	: Body ground	C
F4	B115	Y/2	: Front RH seat belt pre-tensioner					D

D

E

F

G

H

I

J

K

L

PG

N

O

P

HARNESS

< DTC/CIRCUIT DIAGNOSIS >

[SEDAN]

ROOM LAMP HARNESS

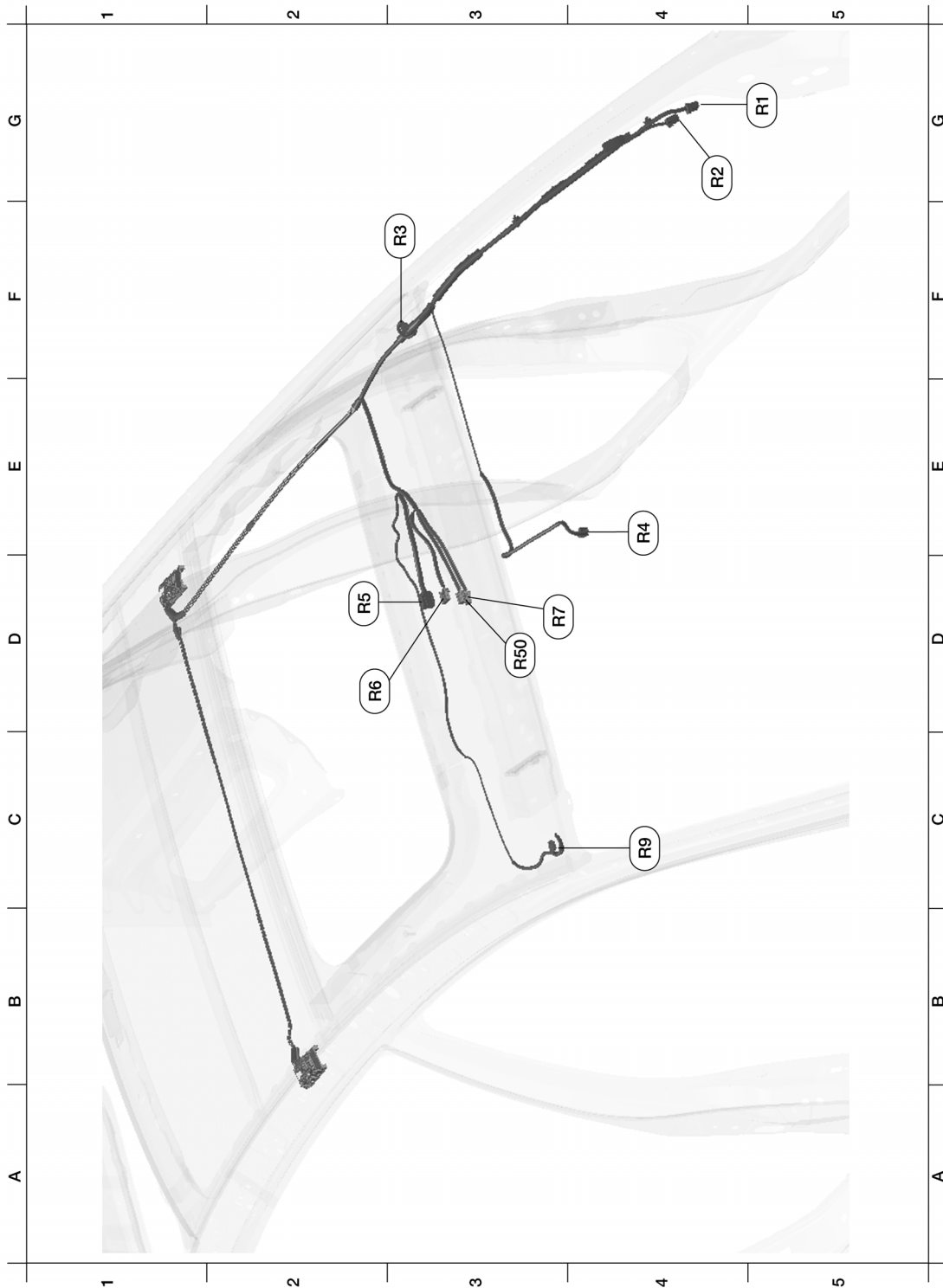

ABMIA2004GB

G5	R1	W/16	: To M7	D3	R6	W/3	: Sunroof switch
G4	R2	W/4	: To M13	D3	R7	W/4	: Microphone
F3	R3	W/2	: Vanity mirror lamp LH	C4	R9	W/2	: Vanity mirror lamp RH
E4	R4	B/7	: Auto anti-dazzling inside mirror	D3	R50	GR/6	: Front room/map lamp assembly
D2	R5	GR/10	: Sunroof motor assembly				

HARNESS

[SEDAN]

< DTC/CIRCUIT DIAGNOSIS >

FRONT DOOR LH HARNESS

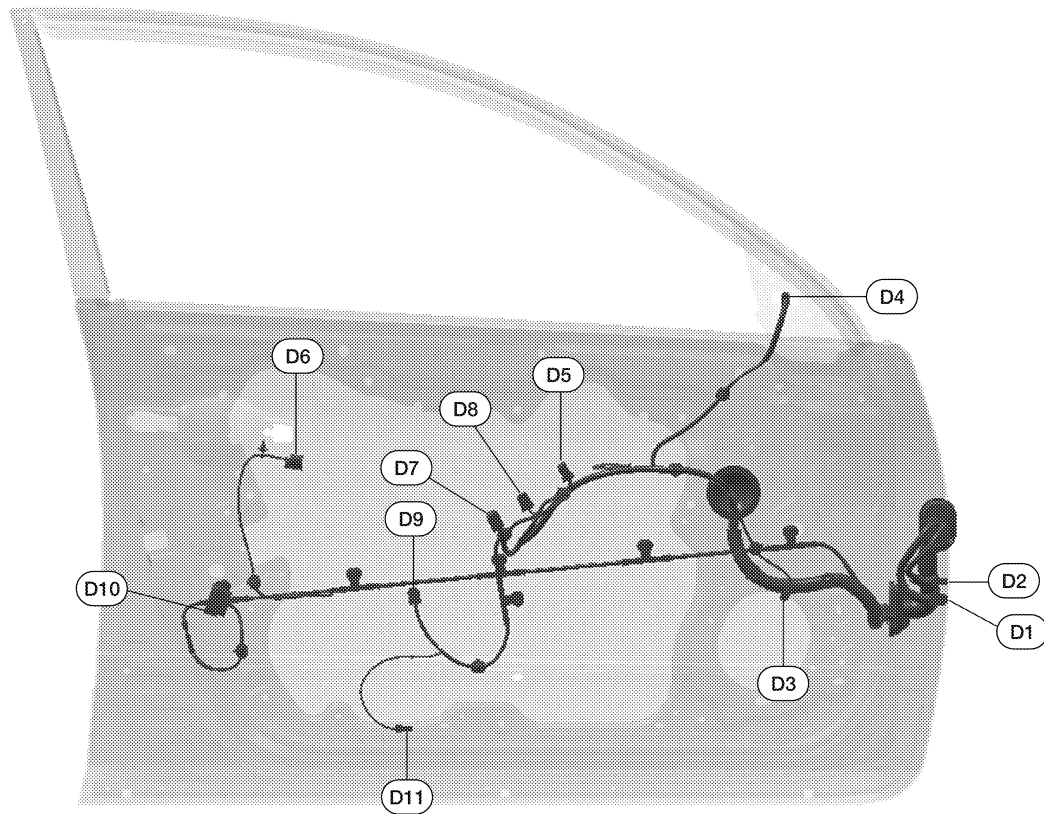

ALMIA0026GB

D1	W/16	: To M11	D6	B/4	: Front outside handle LH
D2	W/16	: To M12	D7	W/16	: Main power window and door lock/unlock switch
D3	W/2	: Front door speaker LH (base audio system)	D8	W/3	: Main power window and door lock/unlock switch
D3	BR/2	: Front door speaker LH (BOSE audio system)	D9	W/6	: Front power window motor LH
D4	W/8	: Door mirror LH	D10	GR/6	: Front door lock assembly LH
D5	W/16	: Door mirror remote control switch	D11	W/2	: Step lamp LH

PG

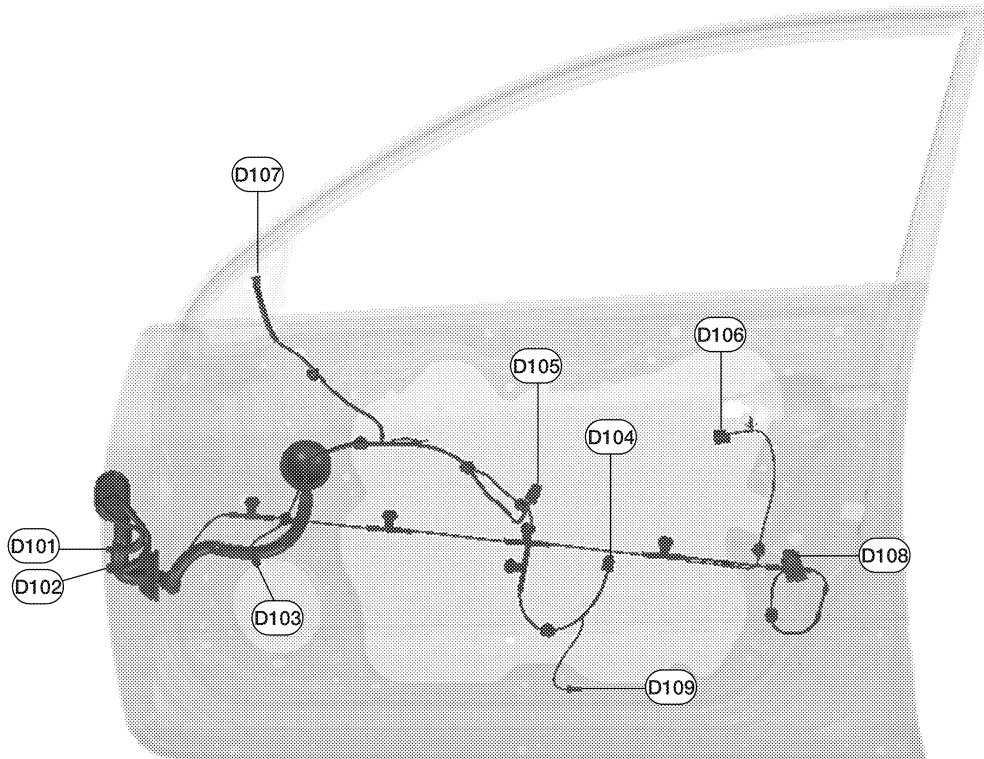

ALMIA0027GB

D101	W/10	: To M14	D105	W/16	: Power window and door lock/unlock switch RH (with left and right front power window anti-pinch system)
D102	W/12	: To M15	D106	B/4	: Front outside handle RH
D103	W/2	: Front door speaker RH (with base audio system)	D107	W/8	: Door mirror RH
D103	BR/2	: Front door speaker RH (with BOSE audio system)	D108	GR/6	: Front door lock actuator RH
D104	W/6	: Front power window motor RH	D109	W/2	: Step lamp RH
D105	W/12	: Power window and door lock/unlock switch RH (with left front only power window anti-pinch system)			

HARNESS

[SEDAN]

< DTC/CIRCUIT DIAGNOSIS >

REAR DOOR LH HARNESS

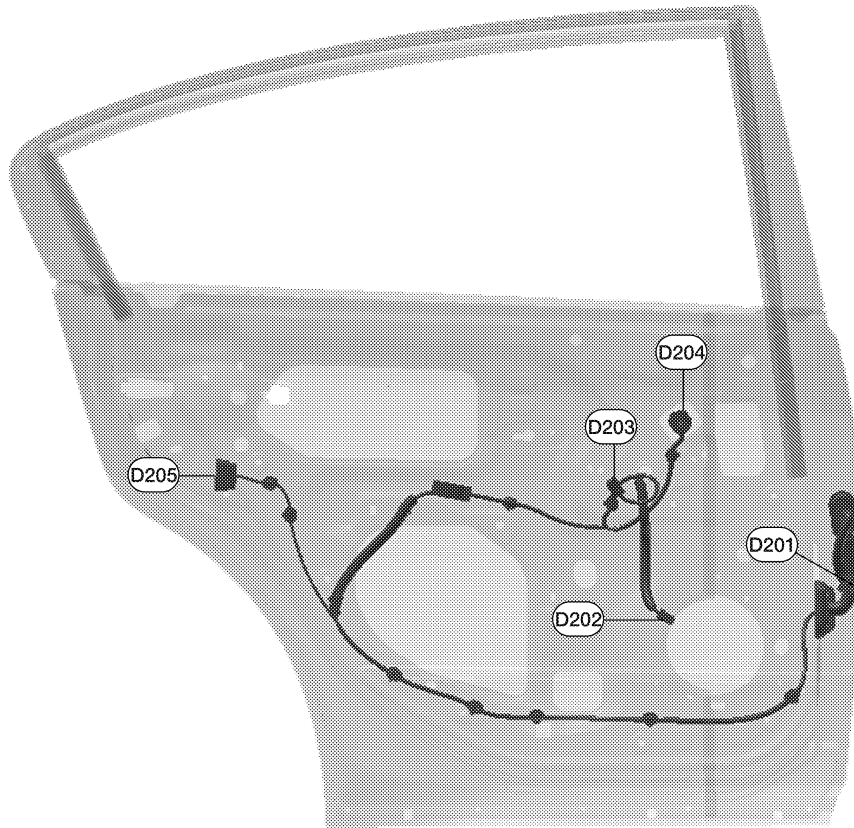

ALMIA0028GB

D201	W/8	: To B6	D204	G/6	: Rear power window motor LH
D202	BR/2	: Rear door speaker LH	D205	GR/6	: Rear door lock actuator LH
D203	W/8	: Rear power window switch LH			

A
B
C
D
E
F
G
H
I
J
K
L

PG

HARNESSES

< DTC/CIRCUIT DIAGNOSIS >

[SEDAN]

REAR DOOR RH HARNESSES

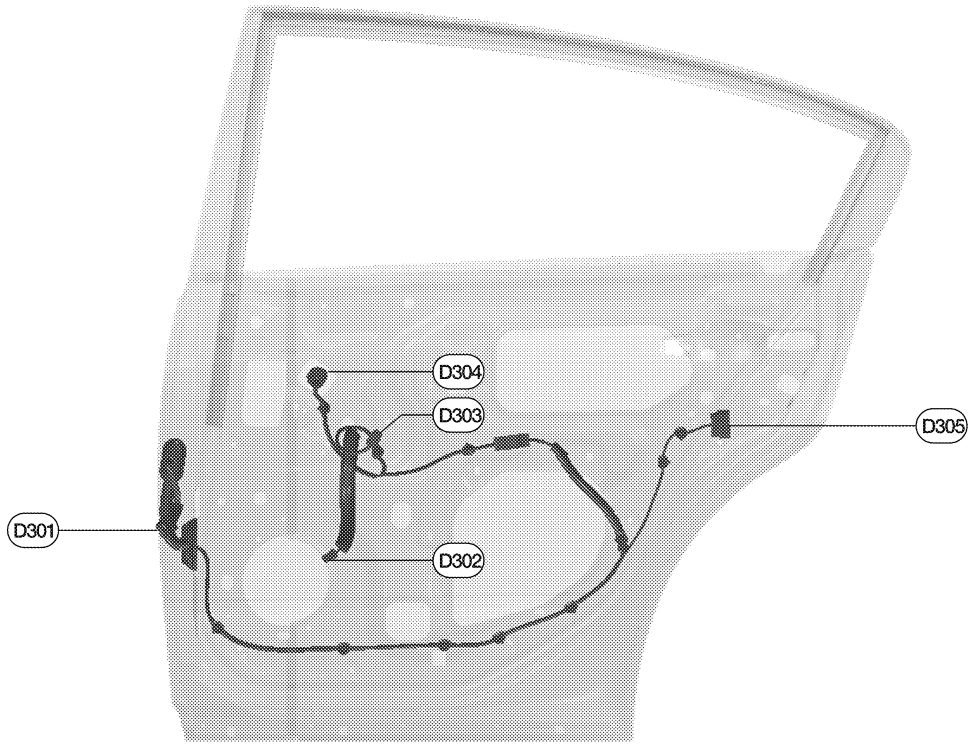

ALMIA0029GB

D301	W/8	: To B106	D304	G/6	: Rear power window motor RH
D302	BR/2	: Rear door speaker RH	D305	GR/6	: Rear door lock actuator RH
D303	W/8	: Rear power window switch RH			

ELECTRICAL UNITS LOCATION

< DTC/CIRCUIT DIAGNOSIS >

[SEDAN]

ELECTRICAL UNITS LOCATION

Electrical Units Location

INFOID:000000007419579

ENGINE COMPARTMENT

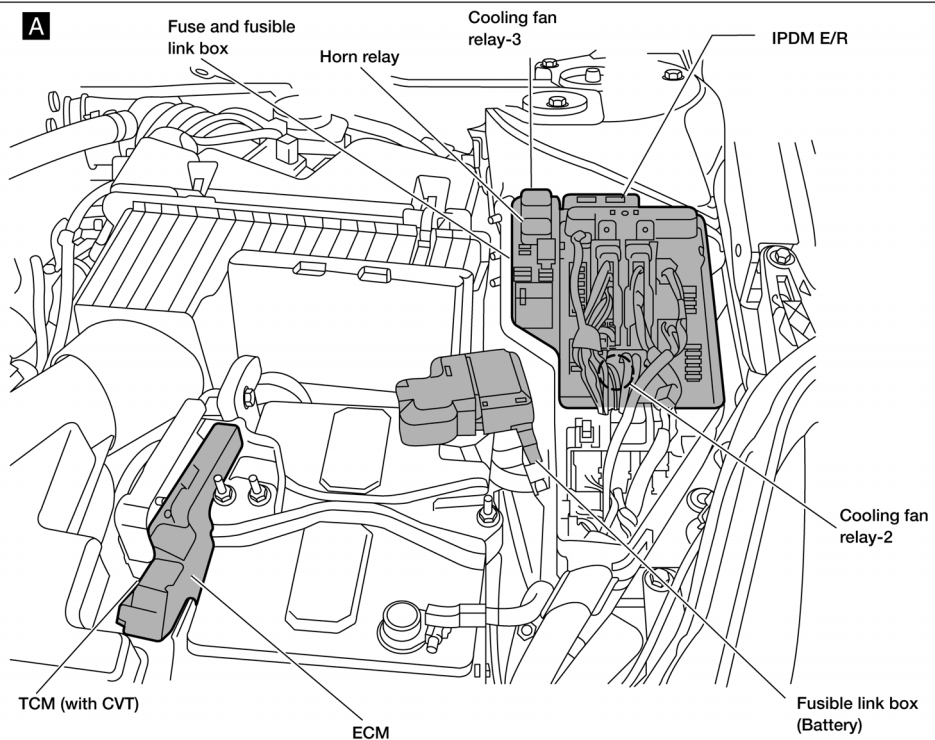
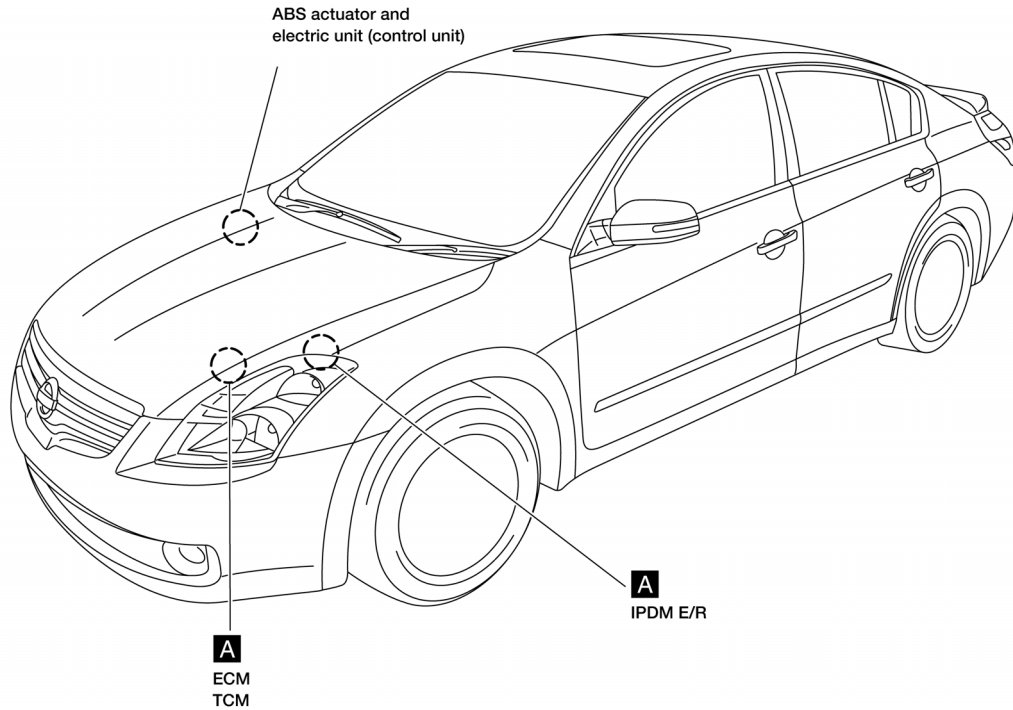

ABMIA1972GB

ELECTRICAL UNITS LOCATION

[SEDAN]

< DTC/CIRCUIT DIAGNOSIS >

PASSENGER COMPARTMENT

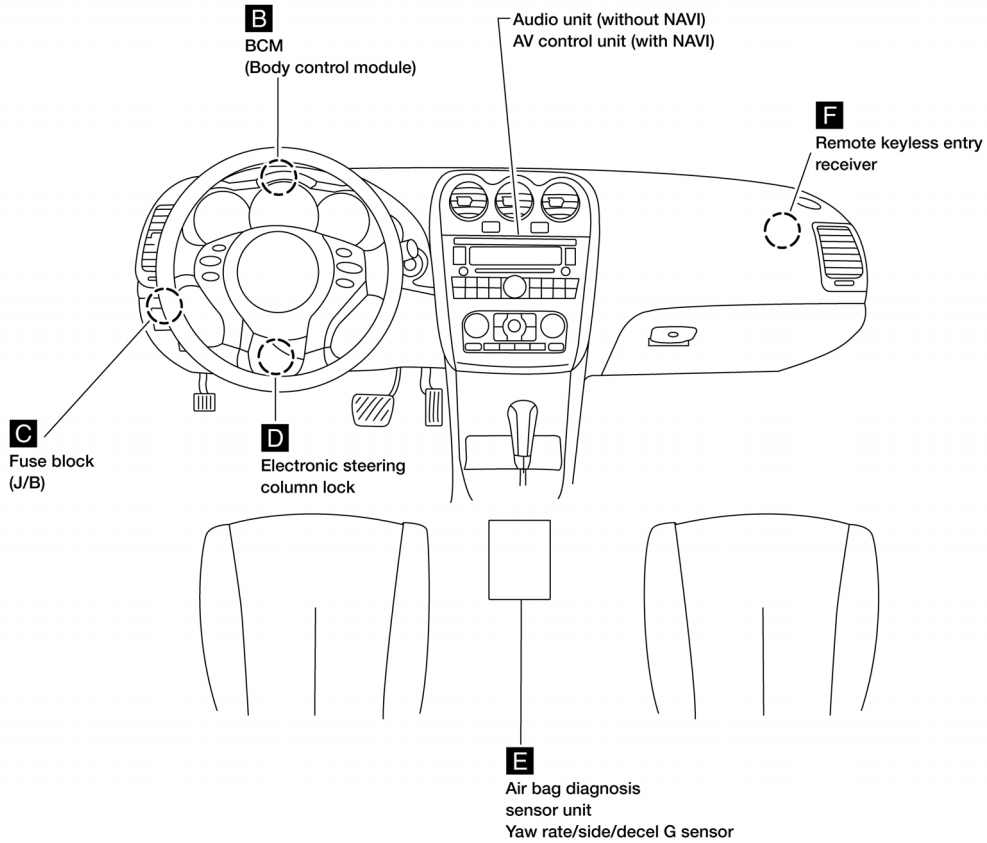

AAMIA0633GB

ELECTRICAL UNITS LOCATION

< DTC/CIRCUIT DIAGNOSIS >

[SEDAN]

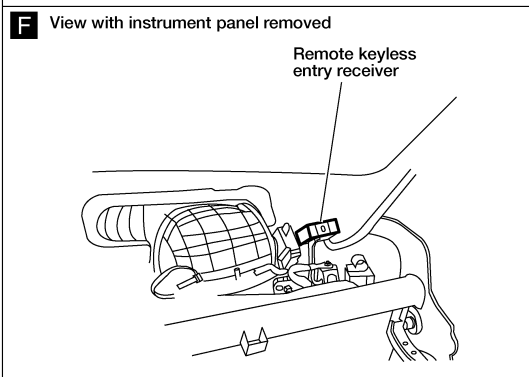
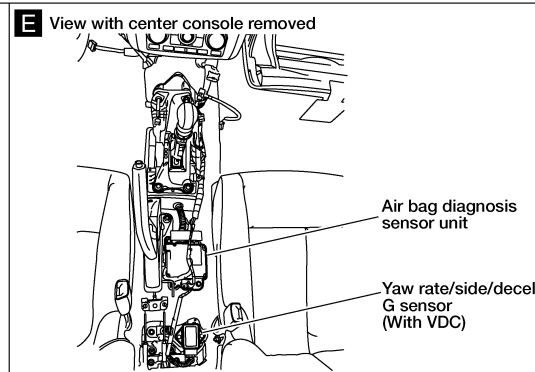
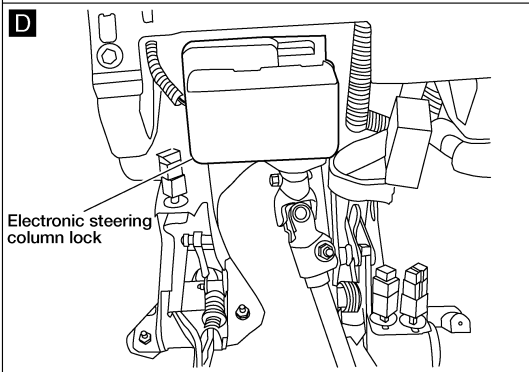
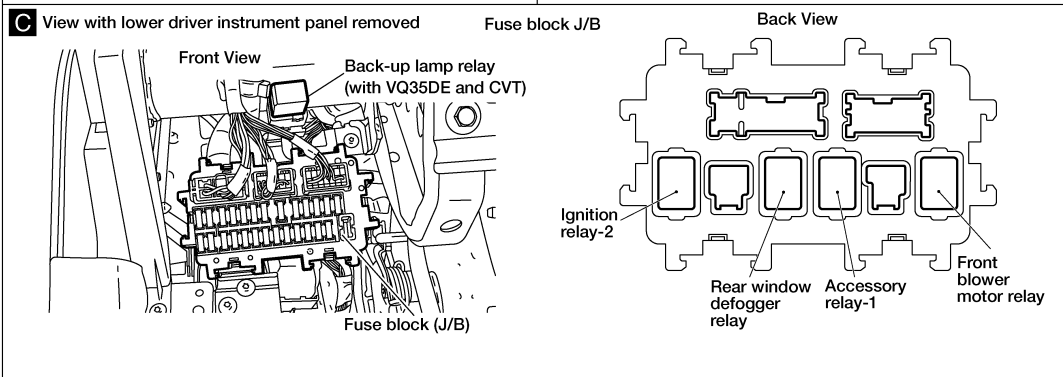
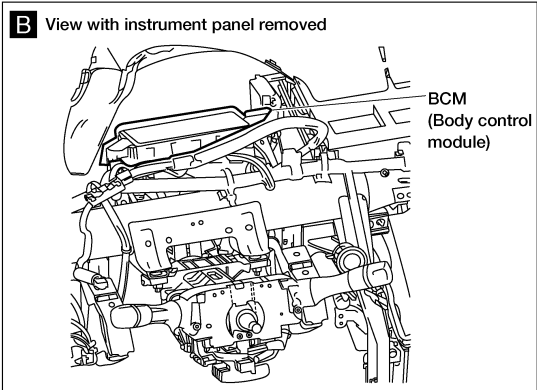

A
B
C
D
E
F
G
H
I
J
K
L
PG
N
O
P

ABMIA4562GB

ELECTRICAL UNITS LOCATION

[SEDAN]

< DTC/CIRCUIT DIAGNOSIS >

LUGGAGE COMPARTMENT

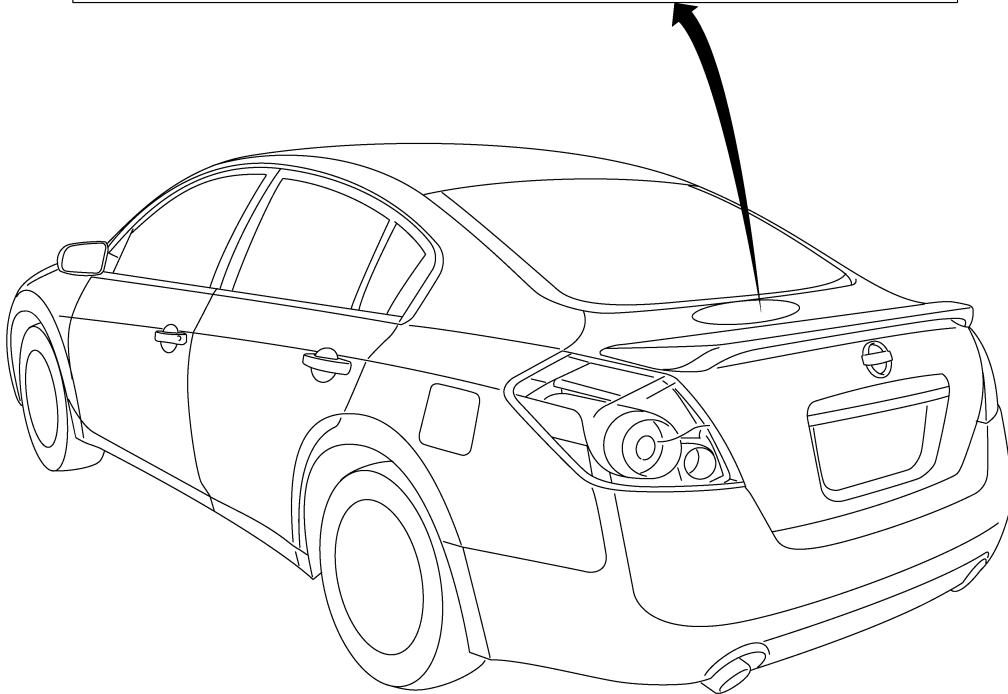
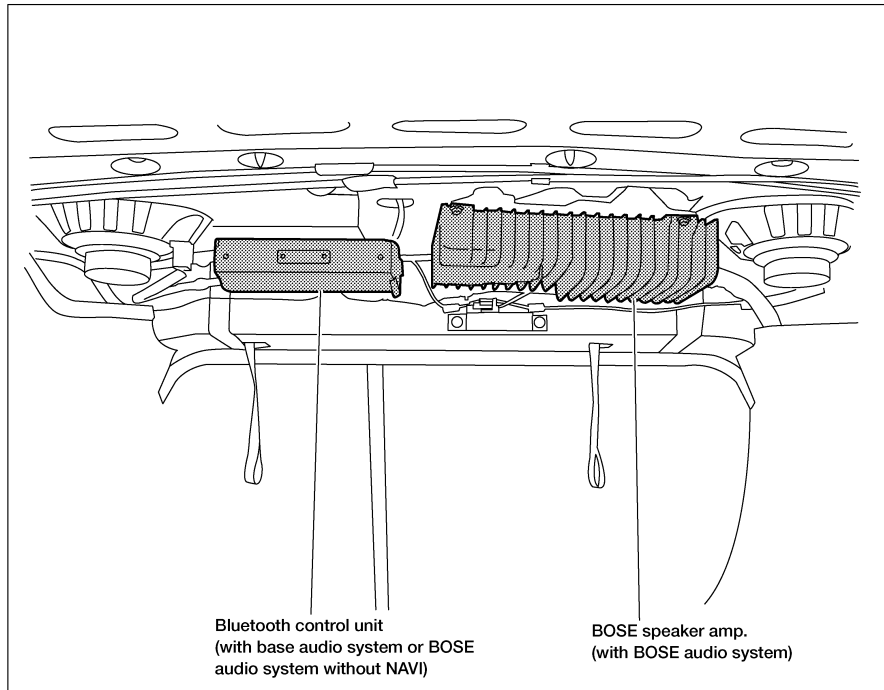

ABMIA3280GB

HARNESS CONNECTOR

Description

INFOID:000000007419580

HARNESS CONNECTOR (TAB-LOCKING TYPE)

- The tab-locking type connectors help prevent accidental looseness or disconnection.
- The tab-locking type connectors are disconnected by pushing or lifting the locking tab(s). Refer to the illustration below.

Refer to the next page for description of the slide-locking type connector.

CAUTION:

Do not pull the harness or wires when disconnecting the connector.

[Example]

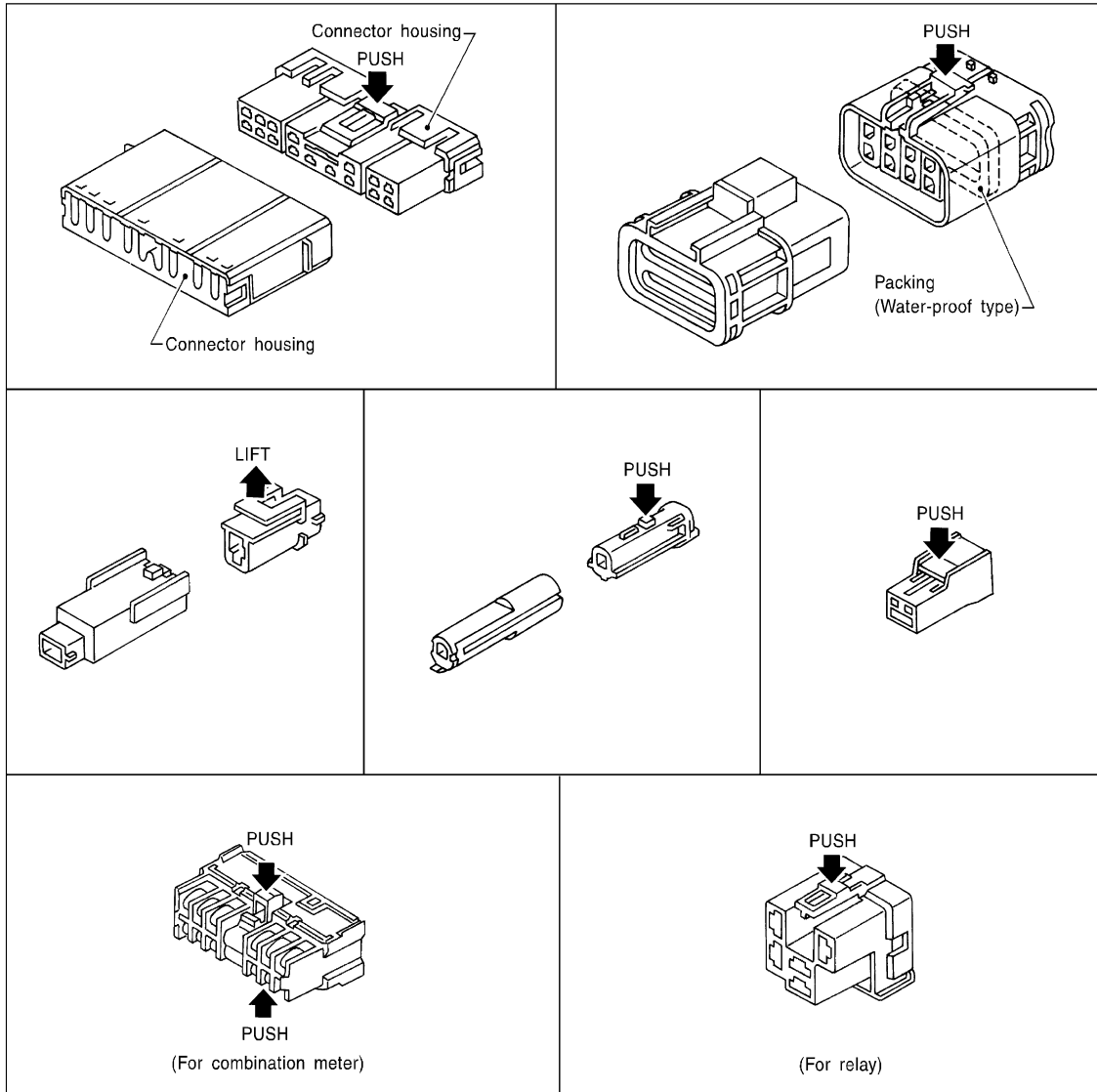

SEL769DA

HARNESS CONNECTOR (SLIDE-LOCKING TYPE)

- A new style slide-locking type connector is used on certain systems and components, especially those related to OBD.
- The slide-locking type connectors help prevent incomplete locking and accidental looseness or disconnection.
- The slide-locking type connectors are disconnected by pushing or pulling the slider. Refer to the illustration below.

A
B
C
D
E
F
G
H
I
J
K
L
PG
N
O
P

HARNESS CONNECTOR

< DTC/CIRCUIT DIAGNOSIS >

[SEDAN]

CAUTION:

- Do not pull the harness or wires when disconnecting the connector.
- Be careful not to damage the connector support bracket when disconnecting the connector.

[Example]

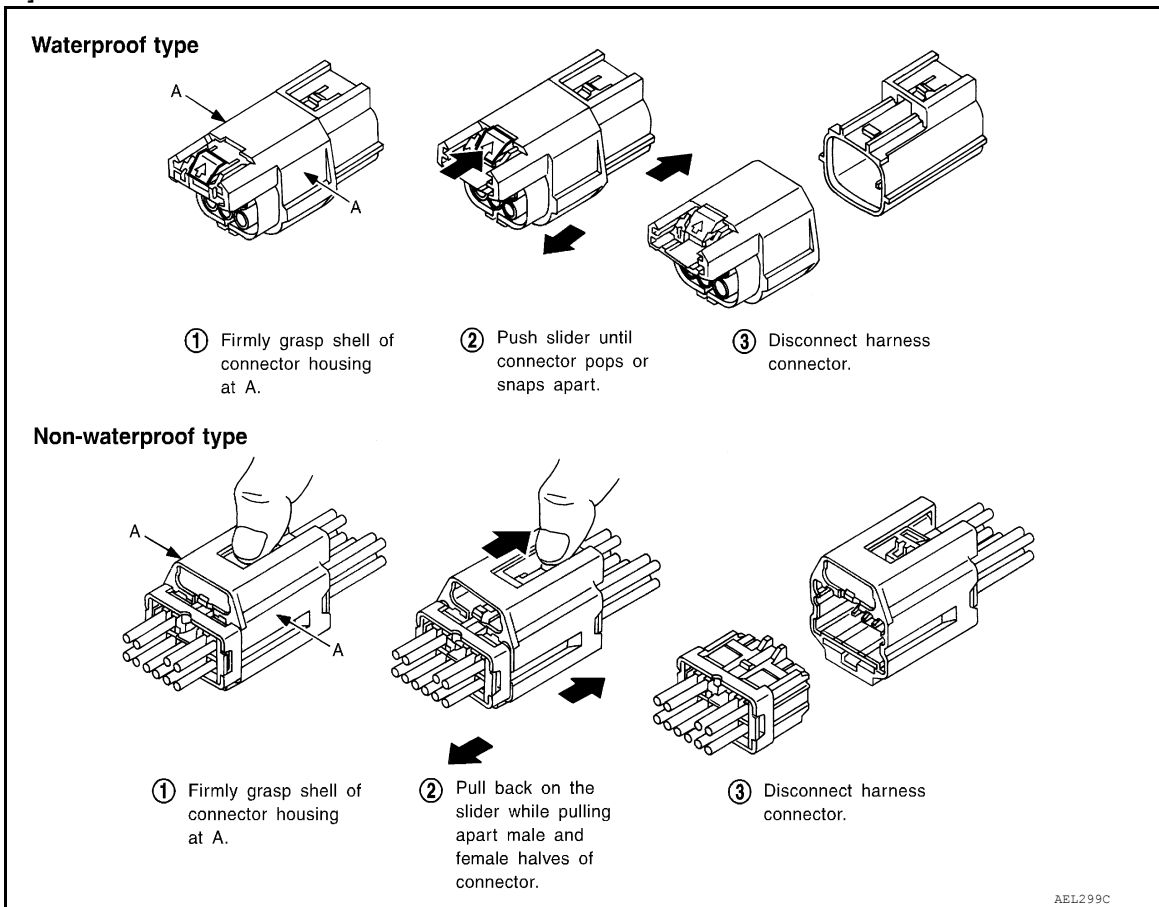

HARNESS CONNECTOR (LEVER LOCKING TYPE)

- Lever locking type harness connectors are used on certain control units and control modules such as ECM, ABS actuator and electric unit (control unit), etc.
- Lever locking type harness connectors are also used on super multiple junction (SMJ) connectors.
- Always confirm the lever is fully locked in place by moving the lever as far as it will go to ensure full connection.

CAUTION:

HARNESS CONNECTOR

< DTC/CIRCUIT DIAGNOSIS >

[SEDAN]

Always confirm the lever is fully released (loosened) before attempting to disconnect or connect these connectors to avoid damage to the connector housing or terminals.

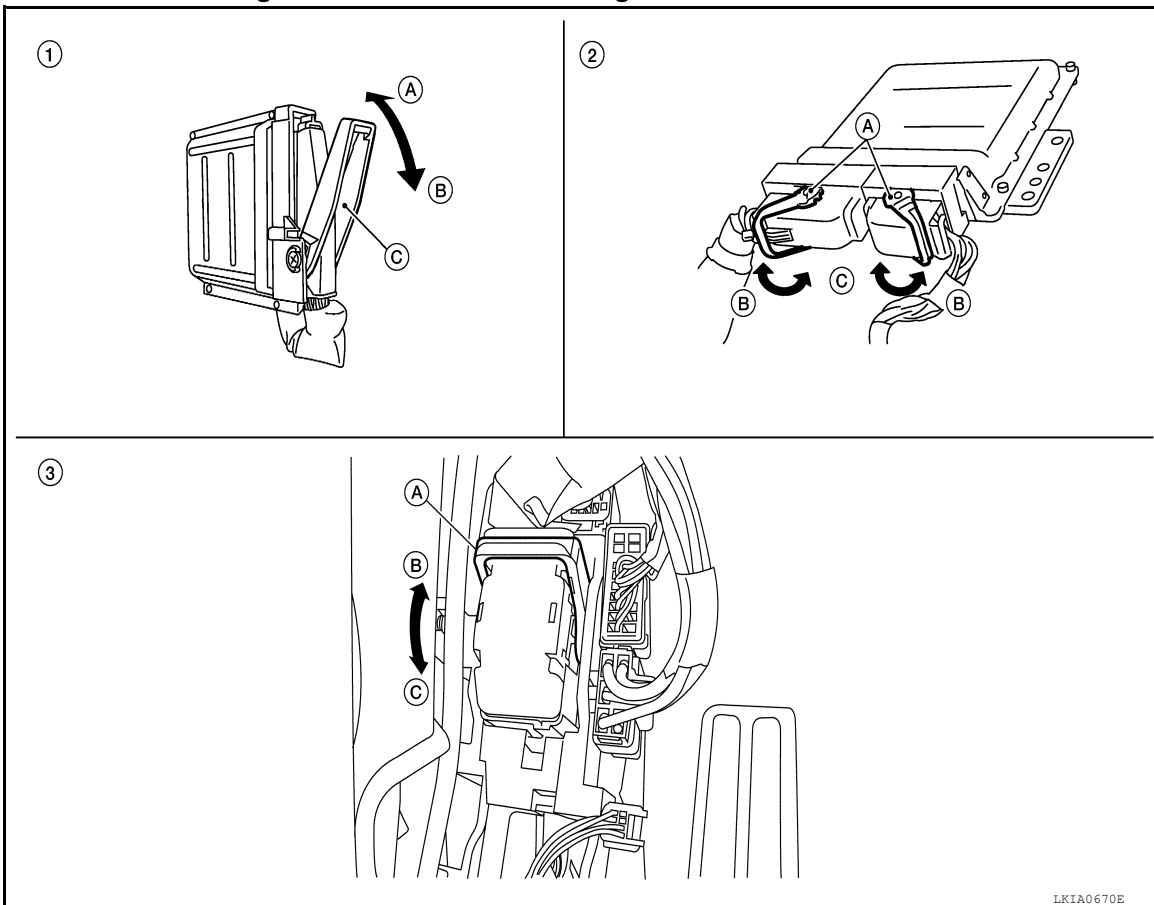

- | | | |
|---|---|--|
| <p>1. Control unit with single lever</p> <ul style="list-style-type: none"> A. Fasten B. Loosen C. Lever | <p>2. Control unit with dual levers</p> <ul style="list-style-type: none"> A. Levers B. Fasten C. Loosen | <p>3. SMJ connector</p> <ul style="list-style-type: none"> A. Lever B. Fasten C. Loosen |
|---|---|--|

HARNESS CONNECTOR (DIRECT-CONNECT SRS COMPONENT TYPE)

- SRS direct-connect type harness connectors are used on certain SRS components such as air bag modules and seat belt pre-tensioners.
- Always pull up to release black locking tab prior to removing connector from SRS component.
- Always push down to lock black locking tab after installing connector to SRS component. When locked, the black locking tab is level with the connector housing.

CAUTION:

- Do not pull the harness or wires when removing connectors from SRS components.

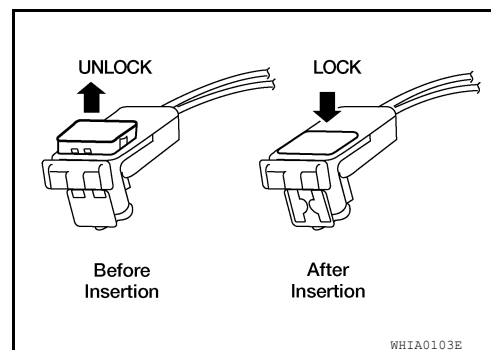

STANDARDIZED RELAY

< DTC/CIRCUIT DIAGNOSIS >

[SEDAN]

STANDARDIZED RELAY

Description

INFOID:000000007419581

NORMAL OPEN, NORMAL CLOSED AND MIXED TYPE RELAYS

Relays can mainly be divided into three types: normal open, normal closed and mixed type relays.

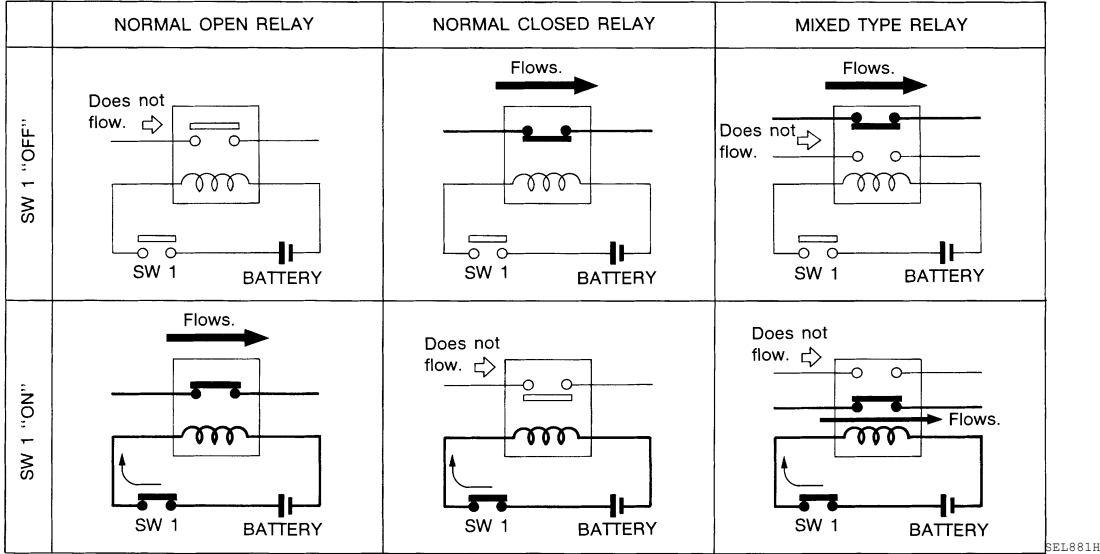

SEL881H

TYPE OF STANDARDIZED RELAYS

- 1M 1 Make
- 2M 2 Make
- 1T 1 Transfer
- 1M·1B 1 Make 1 Break

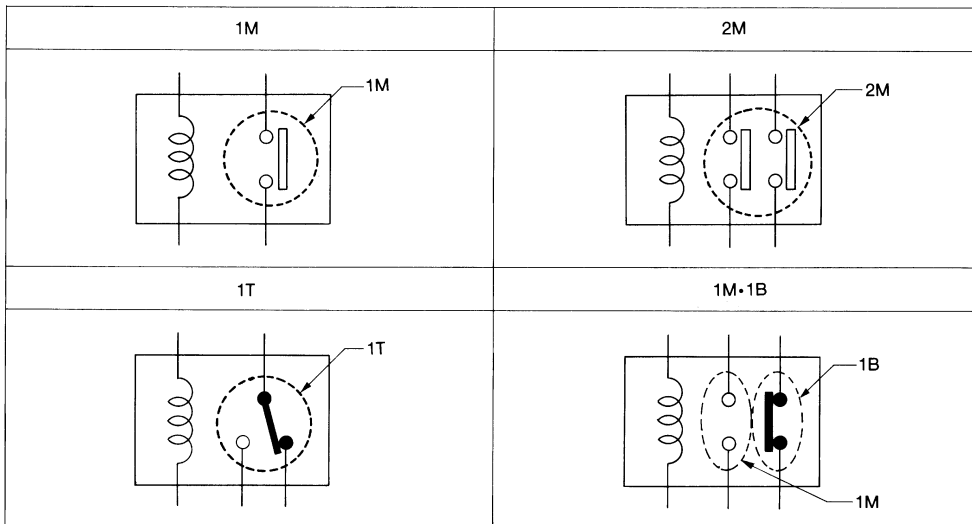

SEL882H

STANDARDIZED RELAY

< DTC/CIRCUIT DIAGNOSIS >

[SEDAN]

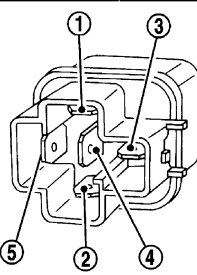
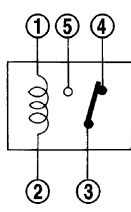
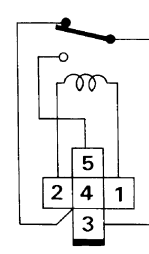
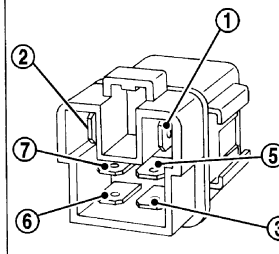
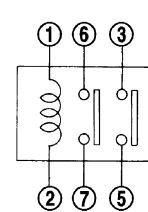
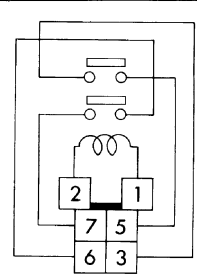
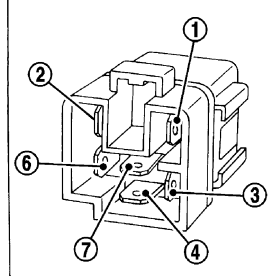
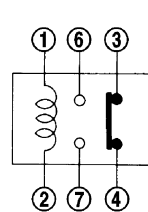
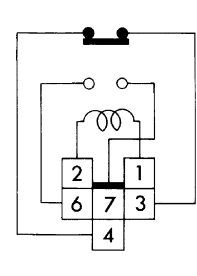
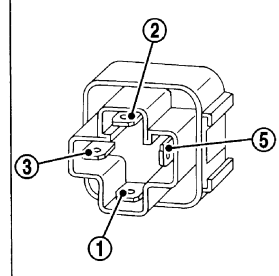
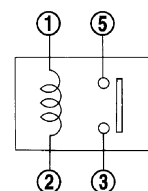
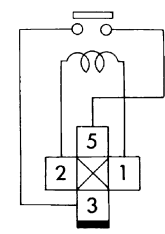
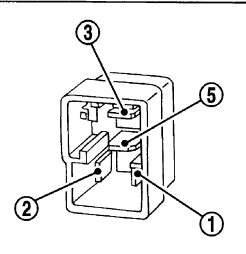
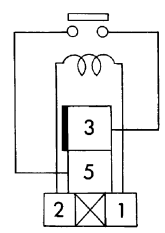
Type	Outer view	Circuit	Connector symbol and connection	Case color
1T				BLACK
2M				BROWN
1M•1B				GRAY
1M				BLUE
				

The arrangement of terminal numbers on the actual relays may differ from those shown above.

SEL188W

A
B
C
D
E
F
G
H
I
J
K
L
PG
N
O
P

FUSE BLOCK - JUNCTION BOX (J/B)

[SEDAN]

< DTC/CIRCUIT DIAGNOSIS >

FUSE BLOCK - JUNCTION BOX (J/B)

Terminal Arrangement

INFOID:000000007419582

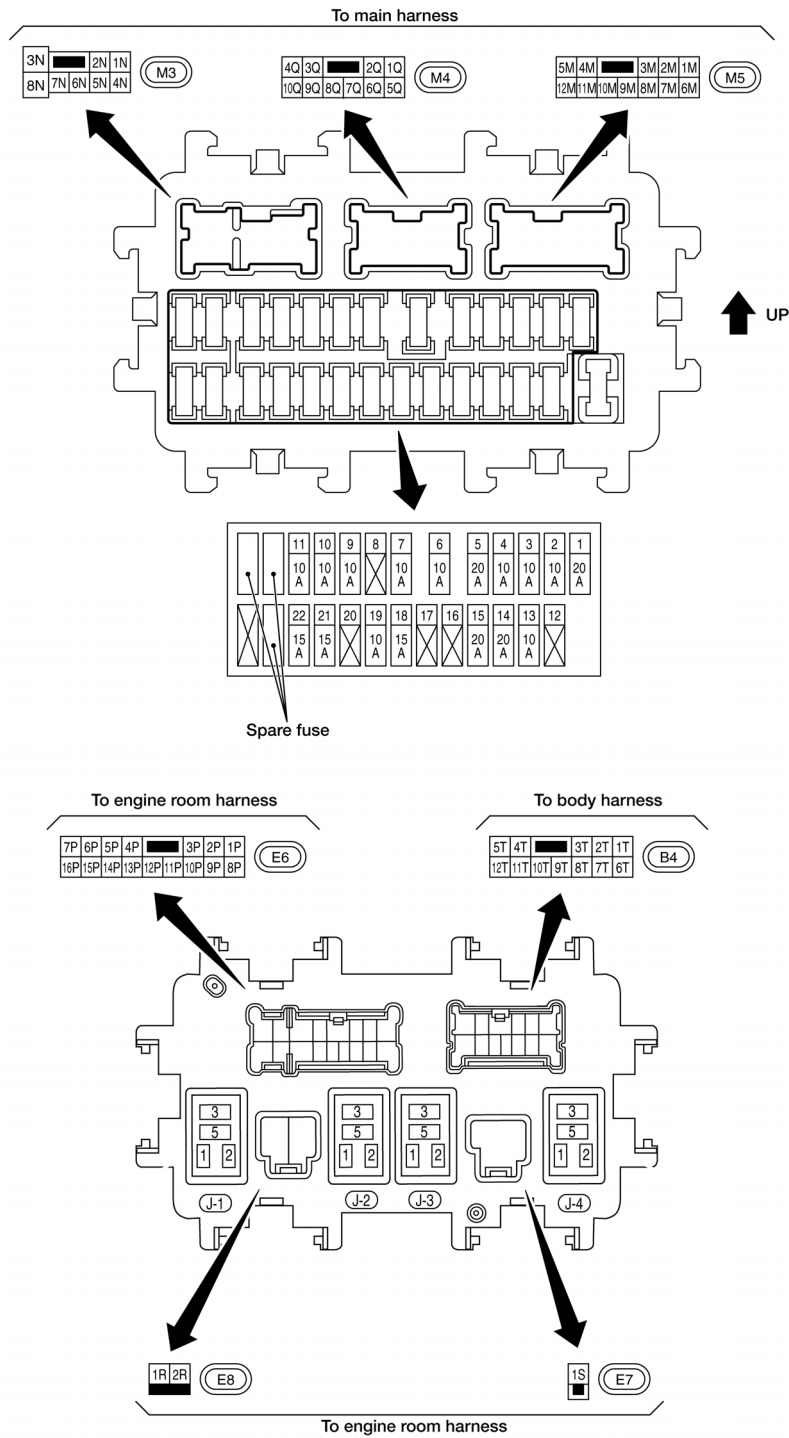

ABMIA1974GB

FUSE, FUSIBLE LINK AND RELAY BOX

< DTC/CIRCUIT DIAGNOSIS >

[SEDAN]

FUSE, FUSIBLE LINK AND RELAY BOX

Terminal Arrangement

INFOID:000000007419583

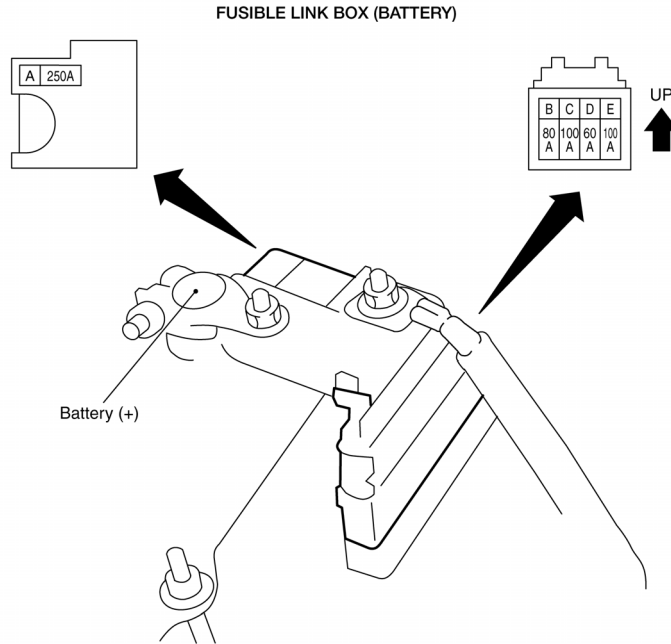

FUSE AND FUSIBLE LINK BOX

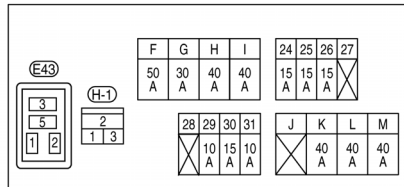

F-M: FUSIBLE LINK
No. 24-31: FUSE

A
B
C
D
E
F
G
H
I
J
K
L
PG
N
O
P

IPDM E/R (INTELLIGENT POWER DISTRIBUTION MODULE ENGINE ROOM)

< DTC/CIRCUIT DIAGNOSIS >

[SEDAN]

IPDM E/R (INTELLIGENT POWER DISTRIBUTION MODULE ENGINE ROOM)

Fuse, Connector and Terminal Arrangement

INFOID:000000007419584

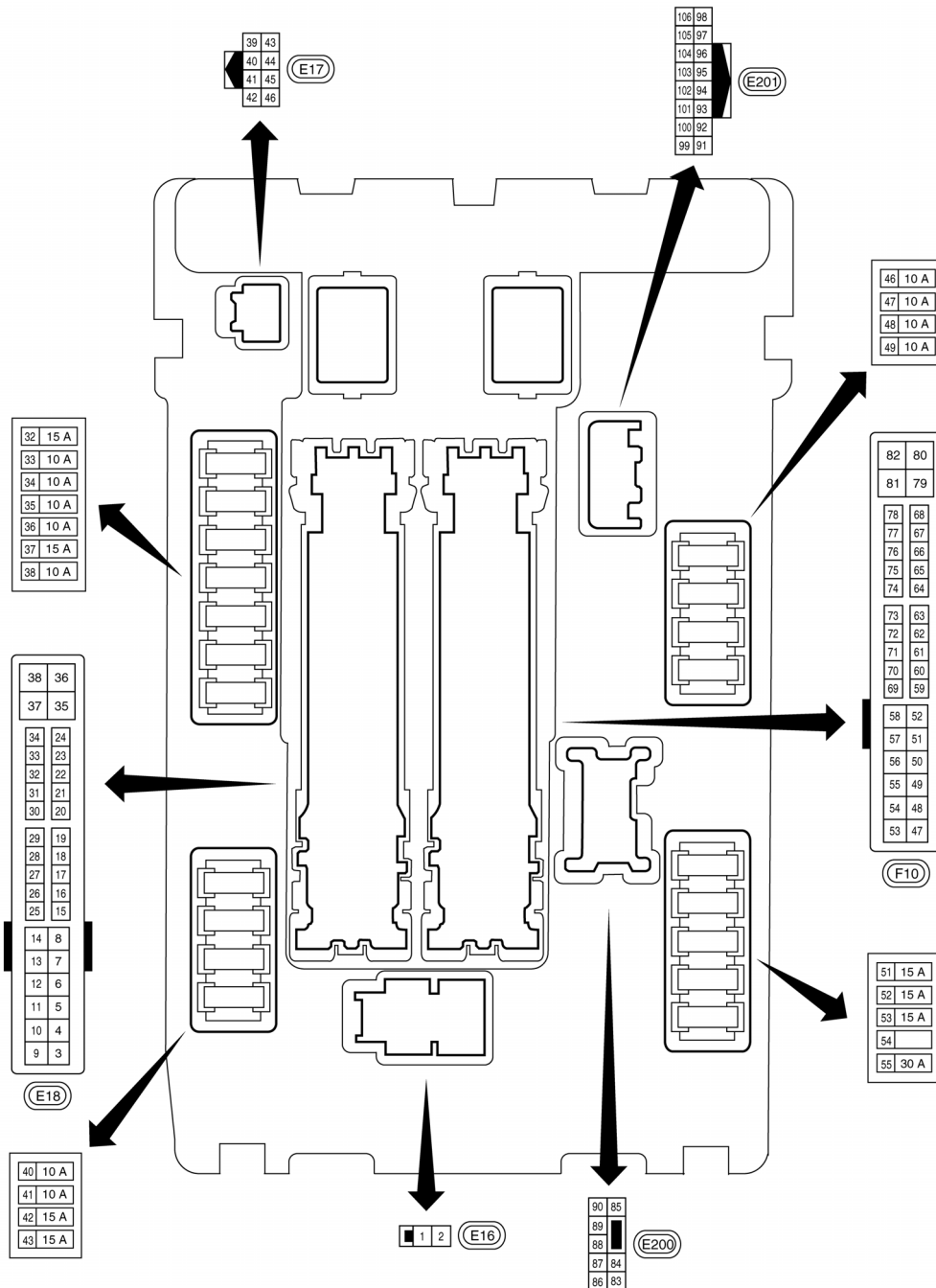

ABMIA1976GB

PRECAUTION

PRECAUTIONS

Precaution for Supplemental Restraint System (SRS) "AIR BAG" and "SEAT BELT PRE-TENSIONER"

INFOID:000000007419585

The Supplemental Restraint System such as "AIR BAG" and "SEAT BELT PRE-TENSIONER", used along with a front seat belt, helps to reduce the risk or severity of injury to the driver and front passenger for certain types of collision. This system includes seat belt switch inputs and dual stage front air bag modules. The SRS system uses the seat belt switches to determine the front air bag deployment, and may only deploy one front air bag, depending on the severity of a collision and whether the front occupants are belted or unbelted. Information necessary to service the system safely is included in the SR and SB section of this Service Manual.

WARNING:

- To avoid rendering the SRS inoperative, which could increase the risk of personal injury or death in the event of a collision which would result in air bag inflation, all maintenance must be performed by an authorized NISSAN/INFINITI dealer.
- Improper maintenance, including incorrect removal and installation of the SRS, can lead to personal injury caused by unintentional activation of the system. For removal of Spiral Cable and Air Bag Module, see the SR section.
- Do not use electrical test equipment on any circuit related to the SRS unless instructed to in this Service Manual. SRS wiring harnesses can be identified by yellow and/or orange harnesses or harness connectors.

PRECAUTIONS WHEN USING POWER TOOLS (AIR OR ELECTRIC) AND HAMMERS

WARNING:

- When working near the Airbag Diagnosis Sensor Unit or other Airbag System sensors with the Ignition ON or engine running, DO NOT use air or electric power tools or strike near the sensor(s) with a hammer. Heavy vibration could activate the sensor(s) and deploy the air bag(s), possibly causing serious injury.
- When using air or electric power tools or hammers, always switch the Ignition OFF, disconnect the battery, and wait at least 3 minutes before performing any service.

Precaution Necessary for Steering Wheel Rotation After Battery Disconnect

INFOID:000000007419586

NOTE:

- Before removing and installing any control units, first turn the push-button ignition switch to the LOCK position, then disconnect both battery cables.
- After finishing work, confirm that all control unit connectors are connected properly, then re-connect both battery cables.
- Always use CONSULT to perform self-diagnosis as a part of each function inspection after finishing work. If a DTC is detected, perform trouble diagnosis according to self-diagnosis results.

This vehicle is equipped with a push-button ignition switch and a steering lock unit.

If the battery is disconnected or discharged, the steering wheel will lock and cannot be turned.

If turning the steering wheel is required with the battery disconnected or discharged, follow the procedure below before starting the repair operation.

OPERATION PROCEDURE

1. Connect both battery cables.

NOTE:

Supply power using jumper cables if battery is discharged.

2. Carry the Intelligent Key or insert it to the key slot and turn the push-button ignition switch to ACC position. (At this time, the steering lock will be released.)
3. Disconnect both battery cables. The steering lock will remain released with both battery cables disconnected and the steering wheel can be turned.
4. Perform the necessary repair operation.

A
B
C
D
E
F
G
H
I
J
K
L
PG
N
O
P

PRECAUTIONS

[SEDAN]

< PRECAUTION >

5. When the repair work is completed, re-connect both battery cables. With the brake pedal released, turn the push-button ignition switch from ACC position to ON position, then to LOCK position. (The steering wheel will lock when the push-button ignition switch is turned to LOCK position.)
6. Perform self-diagnosis check of all control units using CONSULT.

Battery Service

INFOID:000000007419587

Before disconnecting the battery, lower both the driver and passenger windows. This will prevent any interference between the window edge and the vehicle when the door is opened/closed. During normal operation, the window slightly raises and lowers automatically to prevent any window to vehicle interference. The automatic window function will not work with the battery disconnected.

PREPARATION

< PREPARATION >

[SEDAN]

PREPARATION

PREPARATION

Special Service Tool

INFOID:000000007419588

The actual shapes of Kent-Moore tools may differ from those of special service tools illustrated here.

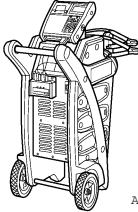
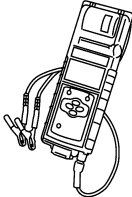
Tool number (Kent Moore No.) Tool name	Description
<p>— (—) Model GR8-1200 NI Multitasking battery and electrical diagnostic station</p>  <p style="text-align: right; font-size: small;">AWIIA1239Z</p>	<p>Tests batteries, starting and charging systems and charges batteries. For operating instructions, refer to diagnostic station instruction manual.</p>
<p>— (—) Model EXP-800 NI Battery and electrical diagnostic analyzer</p>  <p style="text-align: right; font-size: small;">JSMIA0806Z</p>	<p>Tests batteries and charging systems. For operating instructions, refer to diagnostic analyzer instruction manual.</p>

Commercial Service Tool

INFOID:000000007419589

Tool name	Description
<p>Power tool</p>  <p style="text-align: right; font-size: small;">PIIB1407E</p>	<p>Loosening nuts, screws and bolts</p>

A
B
C
D
E
F
G
H
I
J
K
L

PG

BATTERY

< REMOVAL AND INSTALLATION >

[SEDAN]

REMOVAL AND INSTALLATION

BATTERY

Exploded View

INFOID:000000007419590

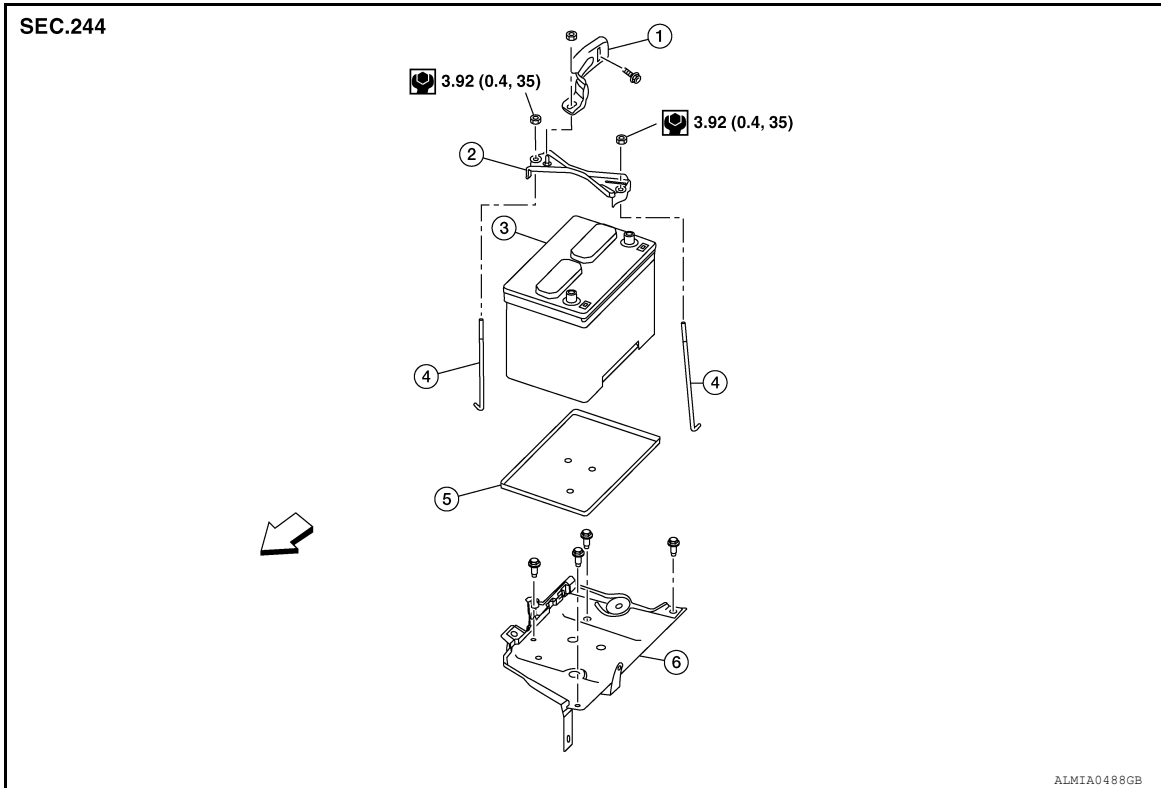

- | | | |
|----------------------|-----------------------|-----------------|
| 1. Upper ECM bracket | 2. Battery frame | 3. Battery |
| 4. Battery rods | 5. Battery tray liner | 6. Battery tray |
- ⇐ Front

Removal and Installation (Battery)

INFOID:000000007419591

REMOVAL

1. Disconnect the battery negative and positive terminals.
CAUTION:
Disconnect the negative terminal first.
2. Remove battery frame nuts and battery frame.
3. Remove battery.

INSTALLATION

Installation is the reverse order of removal.

CAUTION:

When connecting, connect the battery positive terminal first.

Battery frame nut : 3.92 N·m (0.4 kg-m, 35 in-lb)

Battery terminal nut : 5.4 N·m (0.55 kg-m, 48 in-lb)

Reset electronic systems as necessary. Refer to [PG-74. "ADDITIONAL SERVICE WHEN REMOVING BATTERY NEGATIVE TERMINAL : Special Repair Requirement"](#).

BATTERY

< REMOVAL AND INSTALLATION >

[SEDAN]

Removal and Installation (Battery Tray)

INFOID:000000007419592

REMOVAL

1. Remove battery and battery tray liner. Refer to [PG-140, "Removal and Installation \(Battery\)"](#).
2. Remove air cleaner assembly. Refer to [EM-25, "Removal and Installation"](#) (QR25DE models) or [EM-132, "Removal and Installation"](#) (VQ35DE models).
3. Disconnect and remove ECM.
4. Disconnect transmission control module (TCM) (CVT models). Refer to [TM-238, "Removal and Installation"](#) (RE0F09B) or [TM-403, "Removal and Installation"](#) (RE0F10A).
5. Remove the ECM bracket.
6. Remove current sensor from battery tray.
7. Remove the battery tray bolts and battery tray.

INSTALLATION

Installation is in the reverse order of removal.

Reset electronic systems as necessary. Refer to [PG-74, "ADDITIONAL SERVICE WHEN REMOVING BATTERY NEGATIVE TERMINAL : Special Repair Requirement"](#).

A
B
C
D
E
F
G
H
I
J
K
L

PG

N
O
P

BATTERY

< SERVICE DATA AND SPECIFICATIONS (SDS)

[SEDAN]

SERVICE DATA AND SPECIFICATIONS (SDS)

BATTERY

Battery

INFOID:000000007419593

Type*	GR 35
Capacity (20HR) minimum V-AH	12 - 60
Cold cranking current A @ -18°C (0°F)	550

*: Always check with the Parts Department for the latest parts information