

A
EX
C
D
E
F
G
H
I
J
K
L
M
N
O
P

SECTION EX

EXHAUST SYSTEM

CONTENTS

QR25DE	VQ35DE	
PRECAUTION 2	PRECAUTION 7	
PRECAUTIONS 2	PRECAUTIONS 7	
Caution for Supplemental Restraint System (SRS) "AIR BAG" and "SEAT BELT PRE-TENSIONER" 2	Caution for Supplemental Restraint System (SRS) "AIR BAG" and "SEAT BELT PRE-TENSIONER" 7	
PREPARATION 3	PREPARATION 8	
PREPARATION 3	PREPARATION 8	
Special Service Tool 3	Special Service Tool 8	
Commercial Service Tool 3	Commercial Service Tool 8	
PERIODIC MAINTENANCE 4	PERIODIC MAINTENANCE 9	
EXHAUST SYSTEM (QR25DE) 4	EXHAUST SYSTEM (VQ35DE) 9	
Checking Exhaust System 4	Checking Exhaust System 9	
REMOVAL AND INSTALLATION 5	REMOVAL AND INSTALLATION 10	
EXHAUST SYSTEM (QR25DE) 5	EXHAUST SYSTEM (VQ35DE) 10	
Exploded View 5	Exploded View 10	
Removal and Installation 6	Removal and Installation 11	
Inspection After Installation 6	Inspection After Installation 11	

PRECAUTION

PRECAUTIONS

Precaution for Supplemental Restraint System (SRS) "AIR BAG" and "SEAT BELT PRE-TENSIONER"

INFOID:000000007991769

The Supplemental Restraint System such as "AIR BAG" and "SEAT BELT PRE-TENSIONER", used along with a front seat belt, helps to reduce the risk or severity of injury to the driver and front passenger for certain types of collision. Information necessary to service the system safely is included in the SR and SB section of this Service Manual.

WARNING:

- To avoid rendering the SRS inoperative, which could increase the risk of personal injury or death in the event of a collision which would result in air bag inflation, all maintenance must be performed by an authorized NISSAN/INFINITI dealer.
- Improper maintenance, including incorrect removal and installation of the SRS, can lead to personal injury caused by unintentional activation of the system. For removal of Spiral Cable and Air Bag Module, see the SR section.
- Do not use electrical test equipment on any circuit related to the SRS unless instructed to in this Service Manual. SRS wiring harnesses can be identified by yellow and/or orange harnesses or harness connectors.

PRECAUTIONS WHEN USING POWER TOOLS (AIR OR ELECTRIC) AND HAMMERS

WARNING:

- When working near the Airbag Diagnosis Sensor Unit or other Airbag System sensors with the Ignition ON or engine running, DO NOT use air or electric power tools or strike near the sensor(s) with a hammer. Heavy vibration could activate the sensor(s) and deploy the air bag(s), possibly causing serious injury.
- When using air or electric power tools or hammers, always switch the Ignition OFF, disconnect the battery and wait at least 3 minutes before performing any service.

PREPARATION

< PREPARATION >

[QR25DE]

PREPARATION

PREPARATION

Special Service Tool

INFOID:000000007991770

A

EX

The actual shapes of Kent-Moore tools may differ from those of special service tools illustrated here.

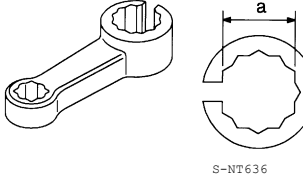
Tool number (Kent-Moore No.) Tool name	Description
KV10114400 (J-38365) Heated oxygen sensor wrench 	Loosening or tightening heated oxygen sensors: a: 22 mm (0.87 in)



C

D

E

Commercial Service Tool

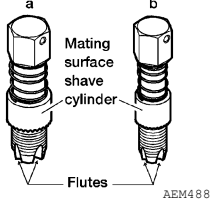
INFOID:000000007991771

(Kent-Moore No.) Tool name	Description
(J-43897-18) (J-43897-12) Oxygen sensor thread cleaner 	Reconditioning the exhaust system threads before installing a new oxygen sensor (Use with anti-seize lubricant shown below): a: J-43897-18 (18 mm dia.) for zirconia oxygen sensor b: J-43897-12 (12 mm dia.) for titania oxygen sensor
Anti-seize lubricant (Permatex 133AR or equivalent meeting MIL specification MIL-A-907) 	Lubricating oxygen sensor thread cleaning tool when reconditioning exhaust system threads
Power tool 	Loosening nuts, screws and bolts

F

G

H

I

J

K

L

M

N

O

P

PERIODIC MAINTENANCE

EXHAUST SYSTEM (QR25DE)

Checking Exhaust System

INFOID:000000007991772

Check the exhaust pipes, muffler, and mounting components for incorrect attachment, leaks, cracks, damage, or deterioration.

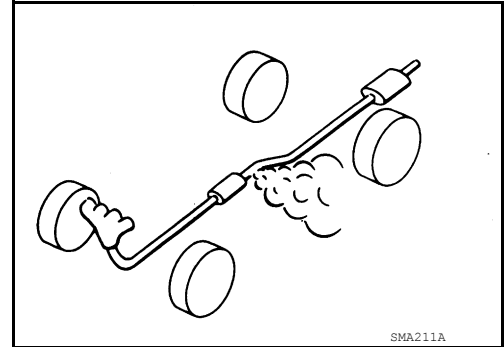

EXHAUST SYSTEM (QR25DE)

< REMOVAL AND INSTALLATION >

[QR25DE]

REMOVAL AND INSTALLATION

EXHAUST SYSTEM (QR25DE)

Exploded View

INFOID:000000007991773

A

EX

SEC. 200

C

D

E

F

G

H

I

J

K

L

M

N

O

P

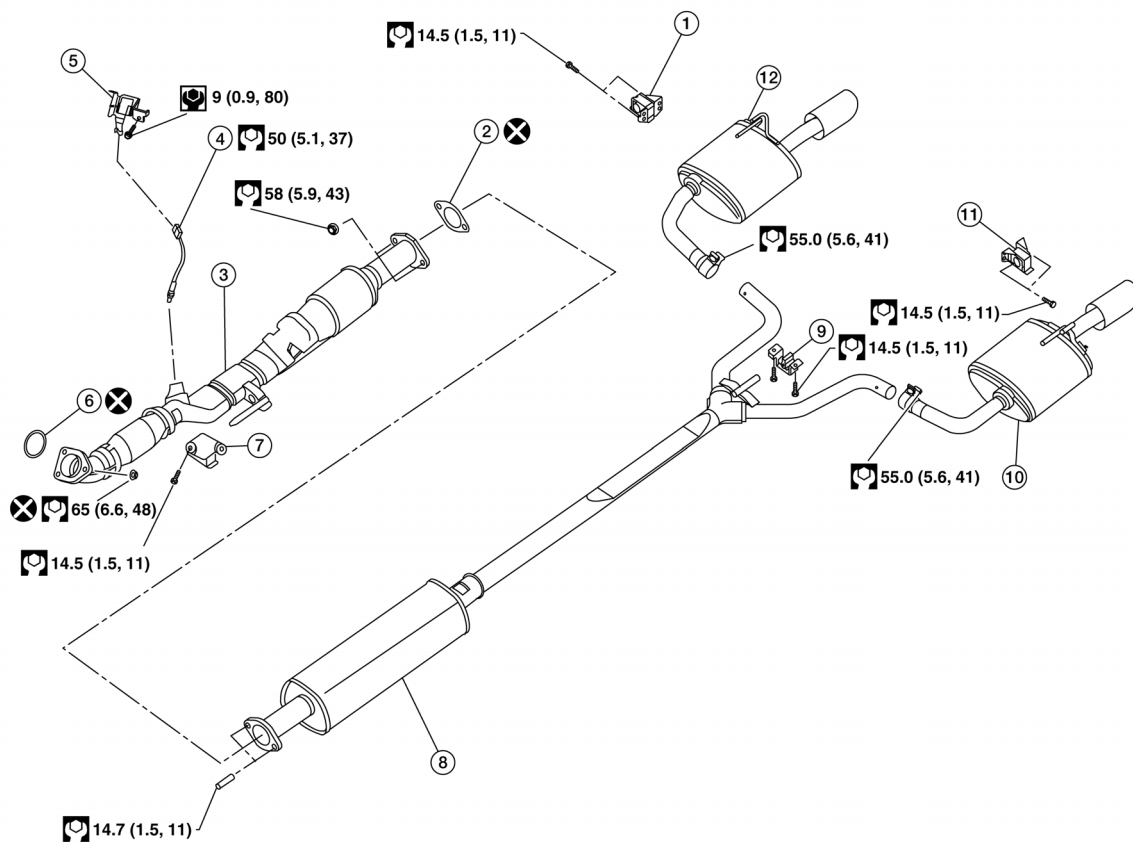

AWBIA1313GB

- | | | |
|------------------------------|-----------------------------|-------------------------------|
| 1. RH rear muffler bracket | 2. Gasket | 3. Front exhaust tube |
| 4. O2 sensor | 5. O2 sensor bracket | 6. Ring gasket |
| 7. Front exhaust tube hanger | 8. Center exhaust tube | 9. Center exhaust tube hanger |
| 10. LH rear muffler | 11. LH rear muffler bracket | 12. RH rear muffler |

EXHAUST SYSTEM (QR25DE)

< REMOVAL AND INSTALLATION >

[QR25DE]

Removal and Installation

INFOID:000000007991774

WARNING:

- Perform the procedure with the exhaust system fully cooled down because the system will be hot just after the engine is turned off.
- Be careful not to cut your hand on the insulator edges.

CAUTION:

- Use genuine NISSAN exhaust system parts or equivalent, which are specifically designed for heat resistance, corrosion resistance, and shape.

REMOVAL

Remove exhaust system components using power tools.

- Remove heated oxygen sensor using Tool as needed.

Tool number : KV10114400 (J-38365)

INSTALLATION

Installation is in the reverse order of removal.

CAUTION:

- Always replace exhaust gaskets with new ones when reassembling.
- Before installing a new heated oxygen sensor, clean and lube the exhaust tube threads using suitable tool.

Oxygen sensor thread cleaner : (J-43897-18)

Oxygen sensor thread cleaner : (J-43897-12)

- Discard any heated oxygen sensor which has been dropped from a height of more than 0.5 m (19.7 in) onto a hard surface such as a concrete floor; install a new one.
- Do not over-tighten the heated oxygen sensor. Doing so may damage the heated oxygen sensor, resulting in the MIL coming on.
- If any mounting insulator is badly deformed, repair or replace it. If deposits such as mud pile up on the mounting insulator, clean and inspect them.
- When installing the insulator avoid large gaps or interference between the insulator and each exhaust pipe.
- Remove deposits from the sealing surface of each connection. Connect them securely to avoid exhaust gas leaks.
- Temporarily tighten the exhaust manifold side nuts and the vehicle side bolts. Check each part for any interference, and then tighten the nuts and bolts to specification.
- When installing each mounting rubber, avoid twisting or excessive extension in up/down and right/left directions.
- Tighten the bolts without causing interference with the flange.

Inspection After Installation

INFOID:000000007991775

- With the engine running, check the exhaust tube joints for exhaust gas leaks and abnormal noise.
- Check that the mounting brackets and mounting insulators are installed properly and free from excessive stress. Improper installation could result in excessive noise, leaks, and vibration.

PRECAUTION

PRECAUTIONS

Precaution for Supplemental Restraint System (SRS) "AIR BAG" and "SEAT BELT PRE-TENSIONER"

INFOID:000000007991776

The Supplemental Restraint System such as "AIR BAG" and "SEAT BELT PRE-TENSIONER", used along with a front seat belt, helps to reduce the risk or severity of injury to the driver and front passenger for certain types of collision. Information necessary to service the system safely is included in the SR and SB section of this Service Manual.

WARNING:

- To avoid rendering the SRS inoperative, which could increase the risk of personal injury or death in the event of a collision which would result in air bag inflation, all maintenance must be performed by an authorized NISSAN/INFINITI dealer.
- Improper maintenance, including incorrect removal and installation of the SRS, can lead to personal injury caused by unintentional activation of the system. For removal of Spiral Cable and Air Bag Module, see the SR section.
- Do not use electrical test equipment on any circuit related to the SRS unless instructed to in this Service Manual. SRS wiring harnesses can be identified by yellow and/or orange harnesses or harness connectors.

PRECAUTIONS WHEN USING POWER TOOLS (AIR OR ELECTRIC) AND HAMMERS

WARNING:

- When working near the Airbag Diagnosis Sensor Unit or other Airbag System sensors with the Ignition ON or engine running, DO NOT use air or electric power tools or strike near the sensor(s) with a hammer. Heavy vibration could activate the sensor(s) and deploy the air bag(s), possibly causing serious injury.
- When using air or electric power tools or hammers, always switch the Ignition OFF, disconnect the battery and wait at least 3 minutes before performing any service.

A
EX
C
D
E
F
G
H
I
J
K
L
M
N
O
P

PREPARATION

< PREPARATION >

[VQ35DE]

PREPARATION

PREPARATION

Special Service Tool

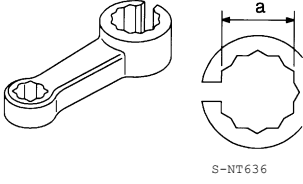

INFOID:000000007991777

The actual shapes of Kent-Moore tools may differ from those of special service tools illustrated here.

Tool number (Kent-Moore No.) Tool name	Description
KV10114400 (J-38365) Heated oxygen sensor wrench <div style="text-align: center;">  <p>S-NT636</p> </div>	Loosening or tightening heated oxygen sensors: a: 22 mm (0.87 in)

Commercial Service Tool

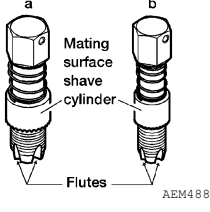
INFOID:000000007991778

(Kent-Moore No.) Tool name	Description
(J-43897-18) (J-43897-12) Oxygen sensor thread cleaner <div style="text-align: center;">  <p>AEM488</p> </div>	Reconditioning the exhaust system threads before installing a new oxygen sensor (Use with anti-seize lubricant shown below): a: J-43897-18 (18 mm dia.) for zirconia oxygen sensor b: J-43897-12 (12 mm dia.) for titania oxygen sensor
Anti-seize lubricant (Permatex 133AR or equivalent meeting MIL specification MIL-A-907) <div style="text-align: center;">  <p>AEM489</p> </div>	Lubricating oxygen sensor thread cleaning tool when reconditioning exhaust system threads
Power tool <div style="text-align: center;">  <p>PIIB1407E</p> </div>	Loosening nuts, screws and bolts

PERIODIC MAINTENANCE

EXHAUST SYSTEM (VQ35DE)

Checking Exhaust System

INFOID:000000007991779

Check the exhaust pipes, muffler, and mounting components for incorrect attachment, leaks, cracks, damage, or deterioration.

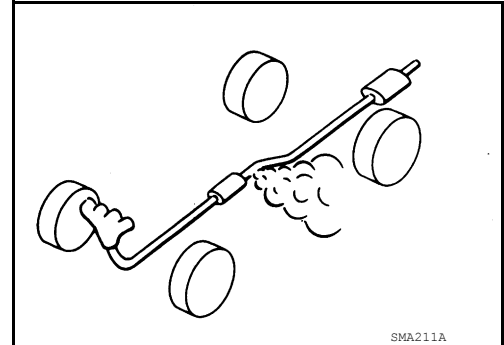

A

EX

C

D

E

F

G

H

I

J

K

L

M

N

O

P

EXHAUST SYSTEM (VQ35DE)

< REMOVAL AND INSTALLATION >

[VQ35DE]

REMOVAL AND INSTALLATION

EXHAUST SYSTEM (VQ35DE)

Exploded View

INFOID:000000007991780

SEC. 200

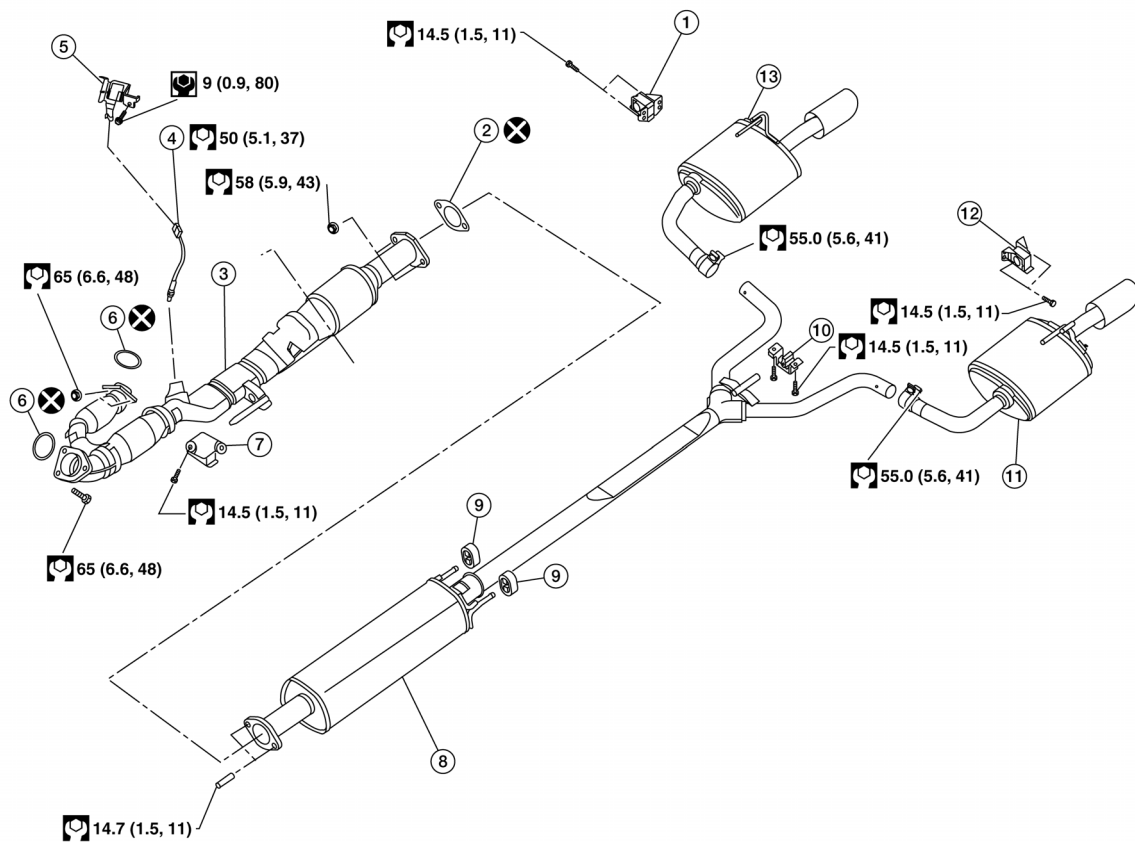

AWBIA1315GB

- | | | |
|--------------------------------|------------------------|-----------------------------|
| 1. RH rear muffler bracket | 2. Gasket | 3. Front exhaust tube |
| 4. O2 sensor | 5. O2 sensor bracket | 6. Ring gasket |
| 7. Front exhaust tube hanger | 8. Center exhaust tube | 9. Mounting rubber |
| 10. Center exhaust tube hanger | 11. LH rear muffler | 12. LH rear muffler bracket |
| 13. RH rear muffler | | |

EXHAUST SYSTEM (VQ35DE)

< REMOVAL AND INSTALLATION >

[VQ35DE]

Removal and Installation

INFOID:000000007991781

A

WARNING:

- Perform the procedure with the exhaust system fully cooled down because the system will be hot just after the engine is turned off.
- Be careful not to cut your hand on the insulator edges.

EX

CAUTION:

- Use genuine NISSAN exhaust system parts or equivalent, which are specifically designed for heat resistance, corrosion resistance, and shape.

C

REMOVAL

Remove exhaust system components using power tools.

- Remove heated oxygen sensor using Tool as needed.

D

Tool number : KV10114400 (J-38365)

E

INSTALLATION

Installation is in the reverse order of removal.

CAUTION:

- Always replace exhaust gaskets with new ones when reassembling.
- Before installing a new heated oxygen sensor, clean and lube the exhaust tube threads using suitable tool.

F

Oxygen sensor thread cleaner : (J-43897-18)

Oxygen sensor thread cleaner : (J-43897-12)

G

- Discard any heated oxygen sensor which has been dropped from a height of more than 0.5 m (19.7 in) onto a hard surface such as a concrete floor; install a new one.
- Do not over-tighten the heated oxygen sensor. Doing so may damage the heated oxygen sensor, resulting in the MIL coming on.
- If any mounting insulator is badly deformed, repair or replace it. If deposits such as mud pile up on the mounting insulator, clean and inspect them.
- When installing the insulator avoid large gaps or interference between the insulator and each exhaust pipe.
- Remove deposits from the sealing surface of each connection. Connect them securely to avoid exhaust gas leaks.
- Temporarily tighten the exhaust manifold side nuts and the vehicle side bolts. Check each part for any interference, and then tighten the nuts and bolts to specification.
- When installing each mounting rubber, avoid twisting or excessive extension in up/down and right/left directions.
- Tighten the bolts without causing interference with the flange.

H

I

J

K

L

Inspection After Installation

INFOID:000000007991782

- With the engine running, check the exhaust tube joints for exhaust gas leaks and unusual noises.
- Check that the mounting brackets and mounting insulators are installed properly and free from excessive stress. Improper installation could result in excessive noise, leaks, and vibration.

M

N

O

P