

# MWI

## SECTION

### METER, WARNING LAMP & INDICATOR

A  
B  
C  
D  
E  
F  
G  
H  
I  
J  
K  
L  
M  
N  
O  
P

## CONTENTS

<b>PRECAUTION</b> .....	<b>FUEL GAUGE : System Diagram</b> .....
4	12
<b>PRECAUTIONS</b> .....	<b>FUEL GAUGE : System Description</b> .....
4	12
Precaution for Supplemental Restraint System (SRS) "AIR BAG" and "SEAT BELT PRE-TENSIONER" .....	<b>MASTER WARNING LAMP</b> .....
4	12
<b>PREPARATION</b> .....	<b>MASTER WARNING LAMP : System Diagram</b> .....
5	13
<b>PREPARATION</b> .....	<b>MASTER WARNING LAMP : System Description</b> .....
5	13
Commercial Service Tools .....	<b>METER ILLUMINATION CONTROL</b> .....
5	13
<b>SYSTEM DESCRIPTION</b> .....	<b>METER ILLUMINATION CONTROL : System Diagram</b> .....
6	13
<b>COMPONENT PARTS</b> .....	<b>METER ILLUMINATION CONTROL : System Description</b> .....
6	13
<b>METER SYSTEM</b> .....	<b>METER EFFECT FUNCTION</b> .....
6	13
METER SYSTEM : Component Parts Location .....	<b>METER EFFECT FUNCTION : System Diagram</b> .....
6	14
METER SYSTEM : Component Description .....	<b>METER EFFECT FUNCTION : System Description</b> .....
7	14
<b>SYSTEM</b> .....	<b>INFORMATION DISPLAY</b> .....
9	15
<b>METER SYSTEM</b> .....	<b>INFORMATION DISPLAY : System Diagram</b> .....
9	15
METER SYSTEM : System Diagram .....	<b>INFORMATION DISPLAY : System Description</b> .....
9	15
METER SYSTEM : System Description .....	<b>COMPASS</b> .....
9	16
METER SYSTEM : Arrangement of Combination	<b>COMPASS : Description</b> .....
Meter .....	16
METER SYSTEM : Fail-Safe .....	<b>DIAGNOSIS SYSTEM (METER)</b> .....
10	18
10	<b>Description</b> .....
	18
	<b>CONSULT Function (METER/M&amp;A)</b> .....
	18
<b>SPEEDOMETER</b> .....	<b>ECU DIAGNOSIS INFORMATION</b> .....
11	22
SPEEDOMETER : System Diagram .....	<b>COMBINATION METER</b> .....
11	22
SPEEDOMETER : System Description .....	Reference Value .....
11	22
<b>TACHOMETER</b> .....	Fail-Safe .....
11	27
TACHOMETER : System Diagram .....	DTC Index .....
12	27
TACHOMETER : System Description .....	<b>BCM, IPDM E/R</b> .....
12	28
<b>ENGINE COOLANT TEMPERATURE GAUGE</b> .....	List of ECU Reference .....
12	28
ENGINE COOLANT TEMPERATURE GAUGE : System Diagram .....	<b>WIRING DIAGRAM</b> .....
12	29
ENGINE COOLANT TEMPERATURE GAUGE : System Description .....	<b>COMPASS</b> .....
12	29
<b>FUEL GAUGE</b> .....	Wiring Diagram .....
12	29

MWI

<b>METER</b> .....	<b>31</b>	<b>WASHER FLUID LEVEL SWITCH CIRCUIT</b> ...	<b>63</b>
Wiring Diagram .....	31	Description .....	63
<b>BASIC INSPECTION</b> .....	<b>50</b>	Diagnosis Procedure .....	63
<b>DIAGNOSIS AND REPAIR WORKFLOW</b> .....	<b>50</b>	Component Inspection .....	63
Work flow .....	50	<b>AMBIENT SENSOR SIGNAL CIRCUIT</b> .....	<b>65</b>
<b>DTC/CIRCUIT DIAGNOSIS</b> .....	<b>52</b>	Description .....	65
<b>U1000 CAN COMM CIRCUIT</b> .....	<b>52</b>	Component Function Check .....	65
DTC Logic .....	52	Diagnosis Procedure .....	65
Diagnosis Procedure .....	52	Component Inspection .....	66
<b>U1010 CONTROL UNIT (CAN)</b> .....	<b>53</b>	<b>METER CONTROL SWITCH SIGNAL CIR-</b>	<b>CUIT</b> .....
Description .....	53	Diagnosis Procedure .....	67
DTC Logic .....	53	Component Inspection .....	68
Diagnosis Procedure .....	53	<b>STEERING SWITCH</b> .....	<b>69</b>
<b>B2205 VEHICLE SPEED</b> .....	<b>54</b>	Description .....	69
Description .....	54	Diagnosis Procedure .....	69
DTC Logic .....	54	Component Inspection .....	69
Diagnosis Procedure .....	54	<b>SYMPTOM DIAGNOSIS</b> .....	<b>71</b>
<b>B2267 ENGINE SPEED</b> .....	<b>55</b>	<b>THE FUEL GAUGE INDICATOR DOES NOT</b>	<b>OPERATE</b> .....
Description .....	55	Description .....	71
DTC Logic .....	55	Diagnosis Procedure .....	71
Diagnosis Procedure .....	55	<b>THE METER CONTROL SWITCH IS INOPER-</b>	<b>ATIVE</b> .....
<b>B2268 WATER TEMP</b> .....	<b>56</b>	Description .....	72
Description .....	56	Diagnosis Procedure .....	72
DTC Logic .....	56	<b>THE OIL PRESSURE WARNING CONTIN-</b>	<b>UES DISPLAYING, OR DOES NOT DISPLAY..</b>
Diagnosis Procedure .....	56	Description .....	73
<b>POWER SUPPLY AND GROUND CIRCUIT</b> ....	<b>57</b>	Diagnosis Procedure .....	73
<b>COMBINATION METER</b> .....	<b>57</b>	<b>THE PARKING BRAKE RELEASE WARNING</b>	<b>CONTINUES DISPLAYING, OR DOES NOT</b>
COMBINATION METER : Diagnosis Procedure ...	57	<b>DISPLAY</b> .....	<b>74</b>
<b>BCM (BODY CONTROL MODULE)</b> .....	<b>57</b>	Description .....	74
BCM (BODY CONTROL MODULE) : Diagnosis		Diagnosis Procedure .....	74
Procedure .....	57	<b>THE LOW WASHER FLUID WARNING CON-</b>	<b>TINUES DISPLAYING, or DOES NOT DIS-</b>
<b>IPDM E/R (INTELLIGENT POWER DISTRIBU-</b>		<b>PLAY</b> .....	<b>75</b>
<b>TION MODULE ENGINE ROOM)</b> .....	<b>58</b>	Description .....	75
IPDM E/R (INTELLIGENT POWER DISTRIBU-		Diagnosis Procedure .....	75
TION MODULE ENGINE ROOM) : Diagnosis Pro-		<b>THE DOOR OPEN WARNING CONTINUES</b>	<b>DISPLAYING, OR DOES NOT DISPLAY</b> .....
cedure .....	58	Description .....	76
<b>FUEL LEVEL SENSOR SIGNAL CIRCUIT</b> .....	<b>60</b>	Diagnosis Procedure .....	76
Description .....	60	<b>THE TRUNK OPEN WARNING CONTINUES</b>	<b>DISPLAYING, OR DOES NOT DISPLAY</b> .....
Component Function Check .....	60	Description .....	77
Diagnosis Procedure .....	60	Diagnosis Procedure .....	77
Component Inspection .....	61	<b>PARKING BRAKE SWITCH SIGNAL CIR-</b>	<b>CUIT</b> .....
<b>PARKING BRAKE SWITCH SIGNAL CIR-</b>		Description .....	62
<b>CUIT</b> .....	<b>62</b>	Component Function Check .....	62
Description .....	62	Diagnosis Procedure .....	62
Component Function Check .....	62	Component Inspection .....	62
Diagnosis Procedure .....	62		
Component Inspection .....	62		

<b>THE STEERING SWITCHES ARE INOPERATIVE</b> .....	<b>78</b>	<b>COMPASS</b> .....	<b>80</b>	
Description .....	78	COMPASS : Description .....	80	A
Diagnosis Procedure .....	78	<b>REMOVAL AND INSTALLATION</b> .....	<b>81</b>	
<b>THE AMBIENT TEMPERATURE DISPLAY IS INCORRECT</b> .....	<b>79</b>	<b>COMBINATION METER</b> .....	<b>81</b>	B
Description .....	79	Removal and Installation .....	81	
Diagnosis Procedure .....	79	<b>AMBIENT SENSOR</b> .....	<b>82</b>	C
<b>NORMAL OPERATING CONDITION</b> .....	<b>80</b>	Removal and Installation .....	82	
				D
				E
				F
				G
				H
				I
				J
				K
				L
				M
				<b>MWI</b>
				O
				P

# PRECAUTIONS

< PRECAUTION >

## PRECAUTION

### PRECAUTIONS

#### Precaution for Supplemental Restraint System (SRS) "AIR BAG" and "SEAT BELT PRE-TENSIONER"

INFOID:000000008725567

The Supplemental Restraint System such as "AIR BAG" and "SEAT BELT PRE-TENSIONER", used along with a front seat belt, helps to reduce the risk or severity of injury to the driver and front passenger for certain types of collision. Information necessary to service the system safely is included in the SR and SB section of this Service Manual.

**WARNING:**

- To avoid rendering the SRS inoperative, which could increase the risk of personal injury or death in the event of a collision which would result in air bag inflation, all maintenance must be performed by an authorized NISSAN/INFINITI dealer.
- Improper maintenance, including incorrect removal and installation of the SRS, can lead to personal injury caused by unintentional activation of the system. For removal of Spiral Cable and Air Bag Module, see the SR section.
- Do not use electrical test equipment on any circuit related to the SRS unless instructed to in this Service Manual. SRS wiring harnesses can be identified by yellow and/or orange harnesses or harness connectors.

#### PRECAUTIONS WHEN USING POWER TOOLS (AIR OR ELECTRIC) AND HAMMERS

**WARNING:**

- When working near the Airbag Diagnosis Sensor Unit or other Airbag System sensors with the Ignition ON or engine running, DO NOT use air or electric power tools or strike near the sensor(s) with a hammer. Heavy vibration could activate the sensor(s) and deploy the air bag(s), possibly causing serious injury.
- When using air or electric power tools or hammers, always switch the Ignition OFF, disconnect the battery and wait at least 3 minutes before performing any service.

# PREPARATION

< PREPARATION >

## PREPARATION

### PREPARATION

#### Commercial Service Tools

INFOID:000000008682976

Tool name	Description
<p data-bbox="162 411 276 441">Power tool</p>  <p data-bbox="831 632 906 646">PIIB1407E</p>	<p data-bbox="1010 411 1347 441">Loosening nuts, screws and bolts</p>

A  
B  
C  
D  
E  
F  
G  
H  
I  
J  
K  
L  
M  
O  
P

MWI

# COMPONENT PARTS

< SYSTEM DESCRIPTION >

## SYSTEM DESCRIPTION

### COMPONENT PARTS

#### METER SYSTEM

#### METER SYSTEM : Component Parts Location

INFOID:000000008659084

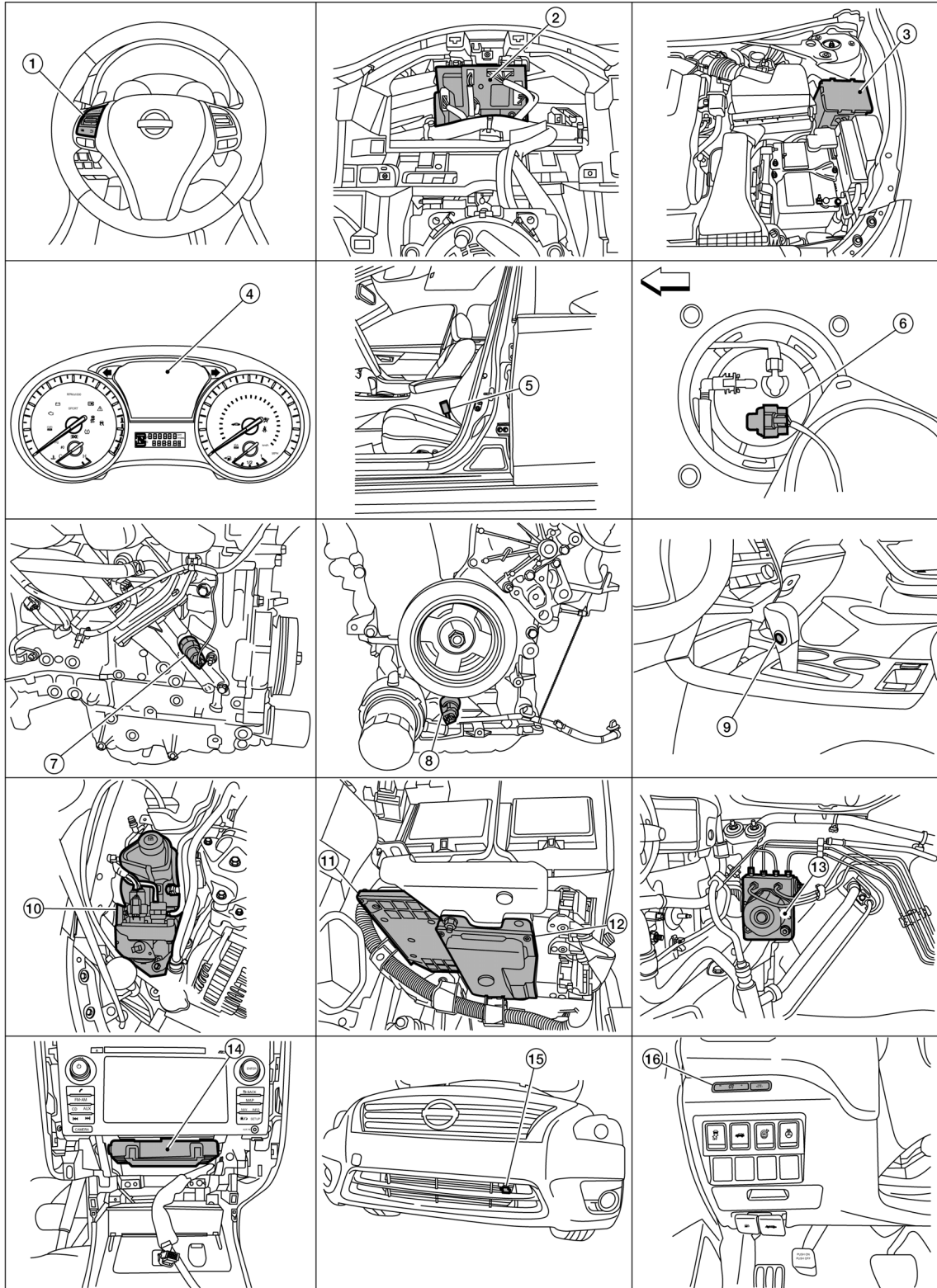

AWN1A2640ZZ

# COMPONENT PARTS

## < SYSTEM DESCRIPTION >

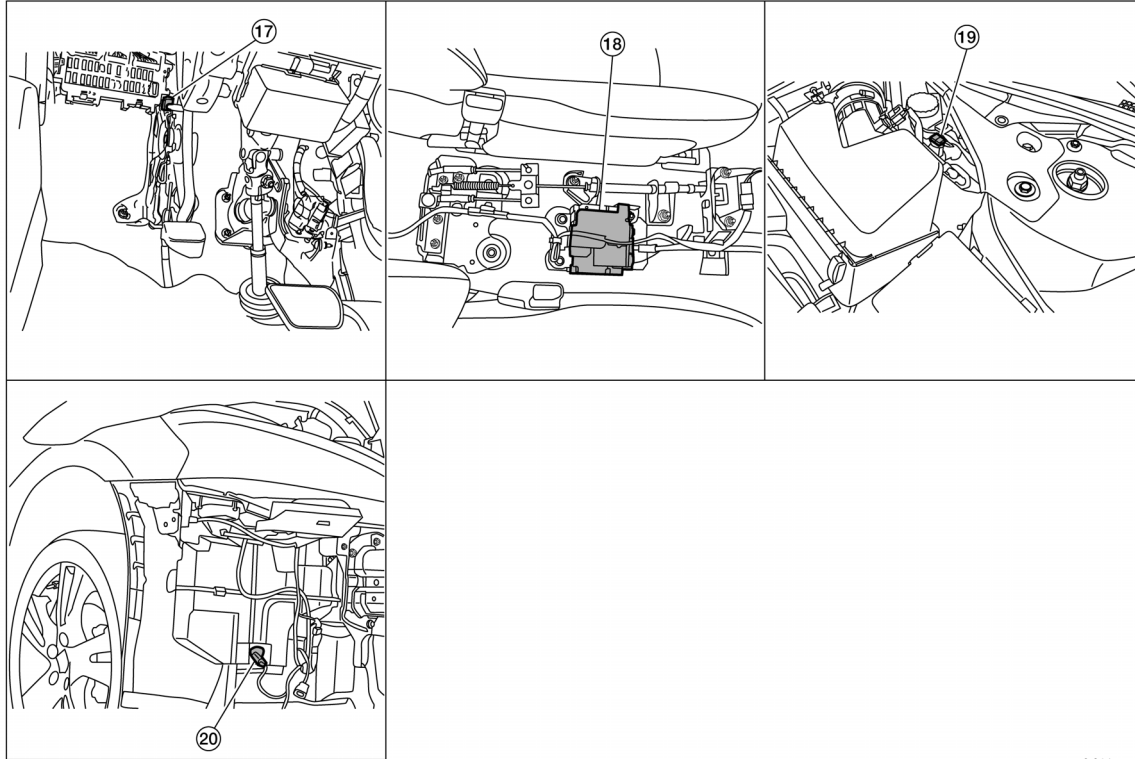

AWNIA26412Z

- |   |  |   |
|---|--|---|
| 1. Steering switch                                | 2. BCM<br>(view with combination meter removed)                                | 3. IPDM E/R   |
| 4. Combination meter                              | 5. Seat belt buckle switch LH<br>(RH similar)                                  | 6. Fuel level sensor unit and fuel pump<br>(view with fuel pump inspection cover removed) |
| 7. Engine oil pressure sensor<br>(QR25DE)         | 8. Engine oil pressure sensor<br>(VQ35DE)                                      | 9. CVT shift selector<br>(O/D OFF switch)   |
| 10. Power steering control module                 | 11. ECM  | 12. TCM   |
| 13. ABS actuator and electric unit (control unit) | 14. A/C auto amp<br>(with auto A/C)<br>(view with A/C switch assembly removed) | 15. Ambient sensor  |
| 16. Meter control switches                        | 17. Parking brake switch<br>(view with lower instrument panel LH removed)      | 18. Air bag diagnosis sensor unit<br>(view with center console assembly removed)          |
| 19. Brake fluid level switch                      | 20. Washer fluid level switch<br>(view with front fascia removed)              |   |

## METER SYSTEM : Component Description

INFOID:000000008659085

MWI

## COMPONENT PARTS

### < SYSTEM DESCRIPTION >

Unit	Description
Combination meter	Controls the following with the signals received from each unit via CAN communication and the signals from switches and sensors: <ul style="list-style-type: none"> <li>• Speedometer</li> <li>• Tachometer</li> <li>• Engine coolant temperature gauge</li> <li>• Fuel gauge</li> <li>• Warning lamps</li> <li>• Indicator lamps</li> <li>• Meter illumination control</li> <li>• Meter effect function</li> <li>• Information display</li> </ul>
Meter control switch	Transmits the following signals to the combination meter: <ul style="list-style-type: none"> <li>• Trip reset switch signal</li> <li>• Illumination control switch signal (+)</li> <li>• Illumination control switch signal (-)</li> </ul>
ECM	Transmits the following signals to the combination meter via CAN communication: <ul style="list-style-type: none"> <li>• Engine speed signal</li> <li>• Engine coolant temperature signal</li> <li>• Engine oil pressure warning signal</li> <li>• Fuel consumption monitor signal</li> </ul>
ABS actuator and electric unit (control unit)	Transmits the vehicle speed signal to the combination meter via CAN communication.
Power steering control module	Transmits the EPS signal to the combination meter via CAN communication.
BCM	Transmits the following signals to the combination meter via CAN communication: <ul style="list-style-type: none"> <li>• Tire pressure information</li> <li>• Position light request signal</li> <li>• Low tire pressure warning lamp signal</li> <li>• Door switch signal</li> <li>• Trunk lamp switch signal</li> </ul>
TCM	Receives the O/D OFF switch signal from the combination meter via CAN communication. Transmits the O/D OFF indicator request signal to the combination meter via CAN communication.
CVT shift selector switch (O/D OFF switch)	Transmits the O/D OFF switch signal to the combination meter
Fuel level sensor unit	Transmits the fuel level sensor signal to the combination meter.
Seat belt buckle switch LH (RH similar)	Transmits the seat belt buckle switch LH signal to the combination meter.
Air bag diagnosis sensor unit	Transmits the following signals to the combination meter: <ul style="list-style-type: none"> <li>• Seat belt buckle switch RH signal</li> <li>• Air bag warning indicator</li> </ul>
Engine oil pressure sensor	Transmits the engine oil pressure sensor signal to the ECM.
Ambient sensor	Transmits the ambient sensor signal to the IPDM E/R.
A/C auto amp.	<ul style="list-style-type: none"> <li>• Receives the ambient sensor signal from the IPDM E/R (with auto A/C).</li> <li>• Transmits the ambient sensor signal to the combination meter via CAN communication.</li> </ul>
Parking brake switch	Transmits the parking brake switch signal to the combination meter.
Washer fluid level switch	Transmits the washer fluid level switch signal to the combination meter.
Steering switch	Transmits the following signals to the information display: <ul style="list-style-type: none"> <li>• Display signal</li> <li>• Menu up signal</li> <li>• Menu down signal</li> <li>• Enter signal</li> <li>• Back signal</li> </ul>
IPDM E/R	<ul style="list-style-type: none"> <li>• Receives the ambient sensor signal from the ambient sensor.</li> <li>• Transmits the ambient sensor signal to the combination meter (without auto A/C).</li> <li>• Transmits the ambient sensor signal to the A/C auto amp (with auto A/C).</li> </ul>
Brake fluid level switch	Transmits the brake fluid level switch signal to the combination meter.



# SYSTEM

< SYSTEM DESCRIPTION >

## SYSTEM

### METER SYSTEM

#### METER SYSTEM : System Diagram

INFOID:000000007985664

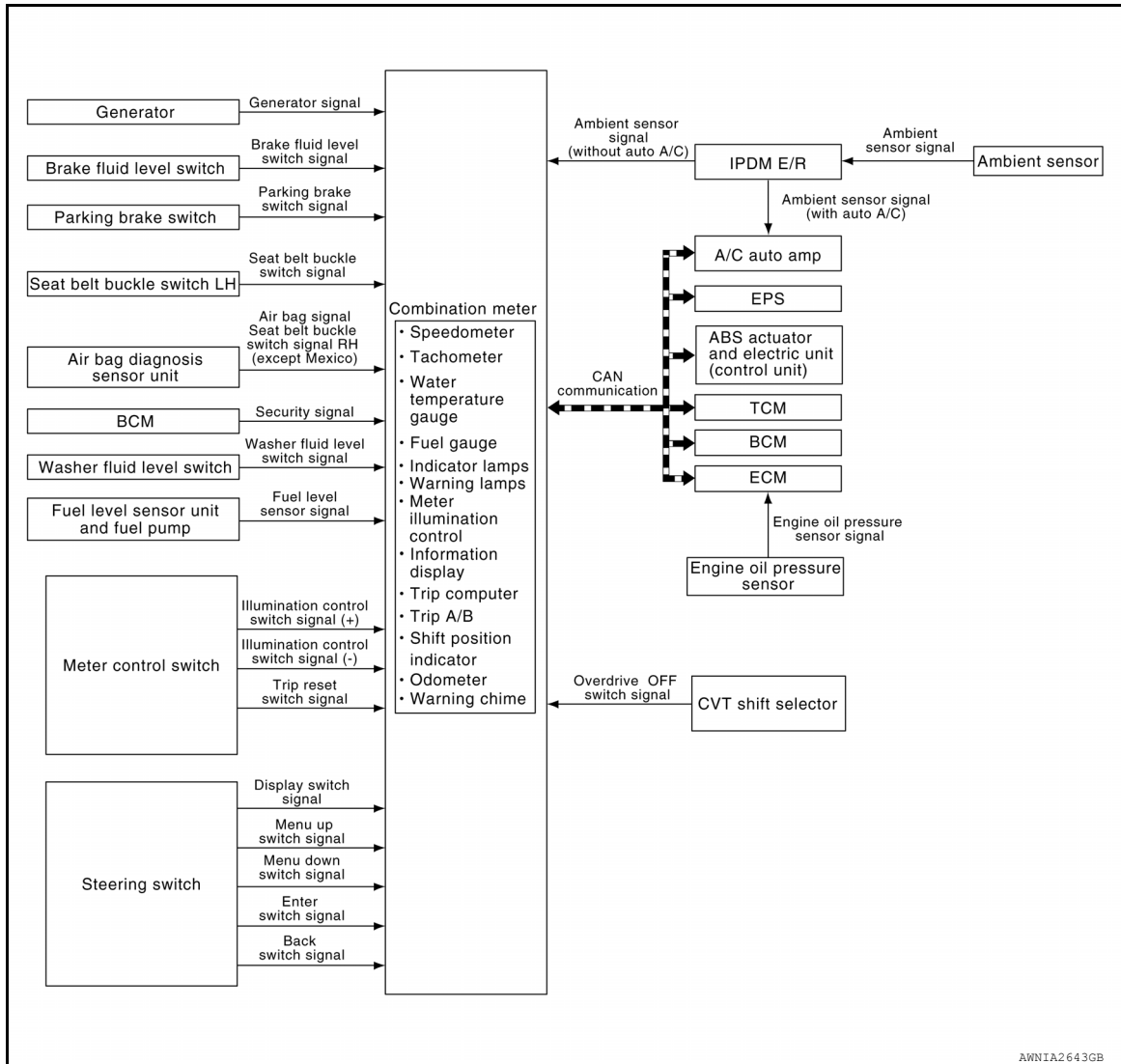

#### METER SYSTEM : System Description

INFOID:000000007985665

##### COMBINATION METER

- The combination meter receives signals from switches, sensors and modules to control the following functions:
  - Speedometer/tachometer
  - Warning lamps
  - Indicator lamps
  - Meter illumination control
  - Meter effect function
  - Information display
- The combination meter has an integrated buzzer that is activated when it receives a signal from the BCM via CAN communication. Refer to [WCS-6, "WARNING CHIME SYSTEM : System Description"](#) for further details.
- The combination meter includes an on-board diagnosis function.
- The combination meter can be diagnosed with CONSULT.

# SYSTEM

< SYSTEM DESCRIPTION >

## METER SYSTEM : Arrangement of Combination Meter

INFOID:00000000798566

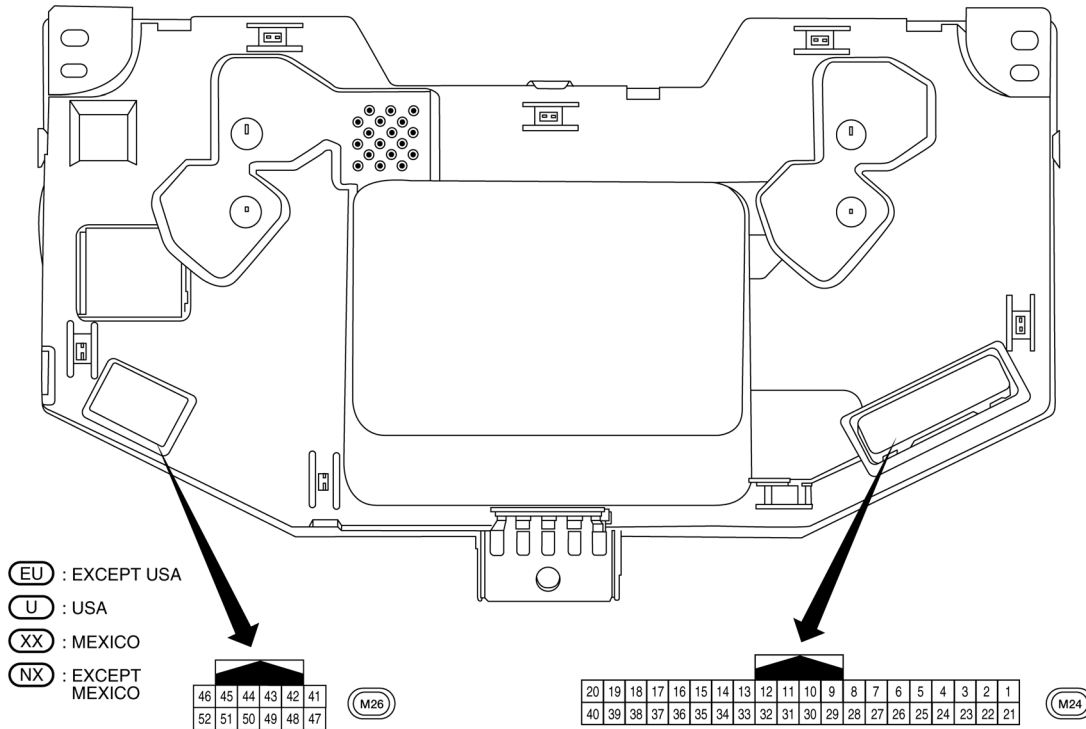
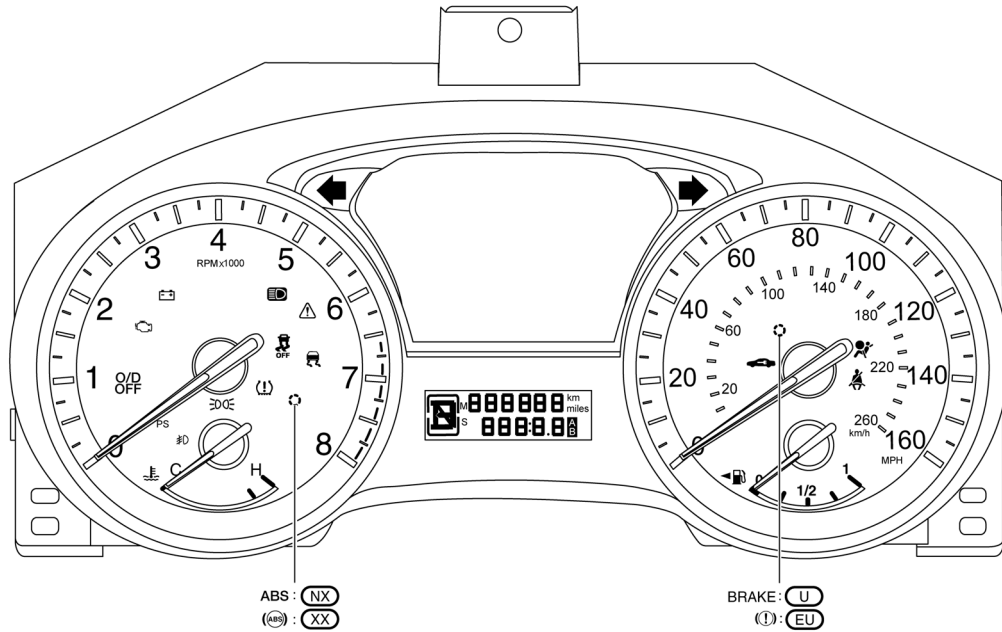

AWNIA2642GB

## METER SYSTEM : Fail-Safe

INFOID:000000000869229

### FAIL-SAFE

The combination meter activates the fail-safe control if CAN communication with each unit is malfunctioning.

# SYSTEM

## < SYSTEM DESCRIPTION >

Function		Specifications
Speedometer		Reset to zero by suspending communication.
Tachometer		
Engine coolant temperature gauge		
Illumination control		When suspending communication, changes to nighttime mode.
Information display	Odo/trip meter	An indicated value is maintained at communications blackout.
	Shift position indicator	The display turns OFF by suspending communication.
	Warning messages	The display turns OFF by suspending communication.
Buzzer		The buzzer turns OFF by suspending communication.
Warning lamp/indicator lamp	ABS warning lamp	The lamp turns ON by suspending communication.
	O/D OFF indicator lamp	
	Slip indicator lamp	
	Brake warning lamp	
	Malfunction indicator lamp	
	VDC OFF indicator lamp	
	EPS warning lamp	
	Low tire pressure warning lamp	The lamp blinking caused by suspending communication.
	High beam indicator lamp	The lamp turns OFF by suspending communication.
	Turn signal indicator lamp	
	Master warning lamp	
	Front lamp indicator lamp	
	Lane departure warning	
	Tail lamp indicator lamp	
	Air bag warning lamp	The lamp turns off when disconnected.
	Charge warning lamp	
Seat belt warning lamp		
Security indicator lamp		

## SPEEDOMETER

### SPEEDOMETER : System Diagram

INFOID:000000007985669

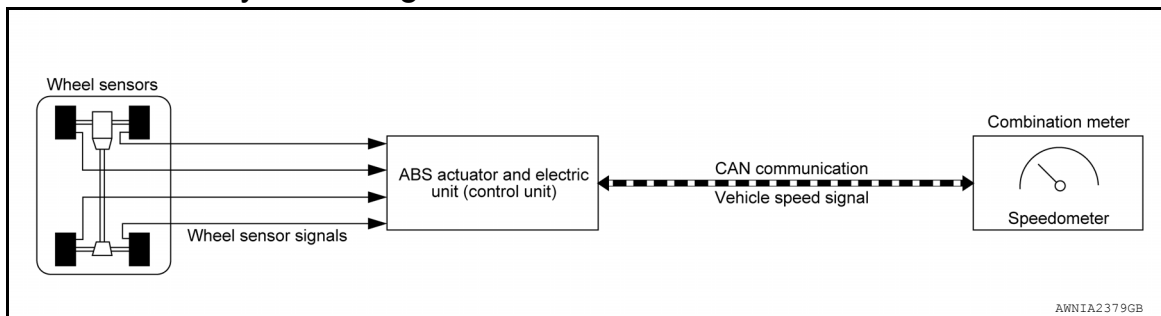

### SPEEDOMETER : System Description

INFOID:000000007985670

The ABS actuator and electric unit (control unit) provides a vehicle speed signal to the combination meter via CAN communication lines.

## TACHOMETER

# SYSTEM

< SYSTEM DESCRIPTION >

## TACHOMETER : System Diagram

INFOID:000000007985673

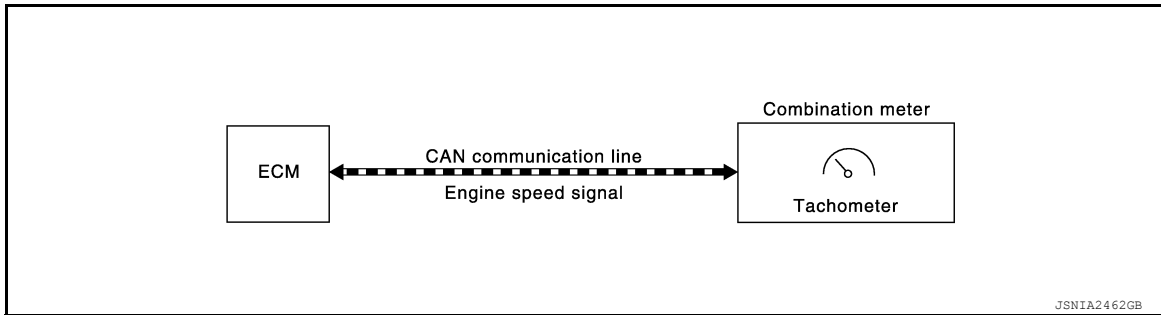

## TACHOMETER : System Description

INFOID:000000007985674

The crank position sensor sends a crankshaft position signal to the ECM. The ECM provides an engine speed signal to the combination meter via CAN communication lines.

The tachometer indicates engine speed in revolutions per minute (rpm).

## ENGINE COOLANT TEMPERATURE GAUGE

### ENGINE COOLANT TEMPERATURE GAUGE : System Diagram

INFOID:000000007985677

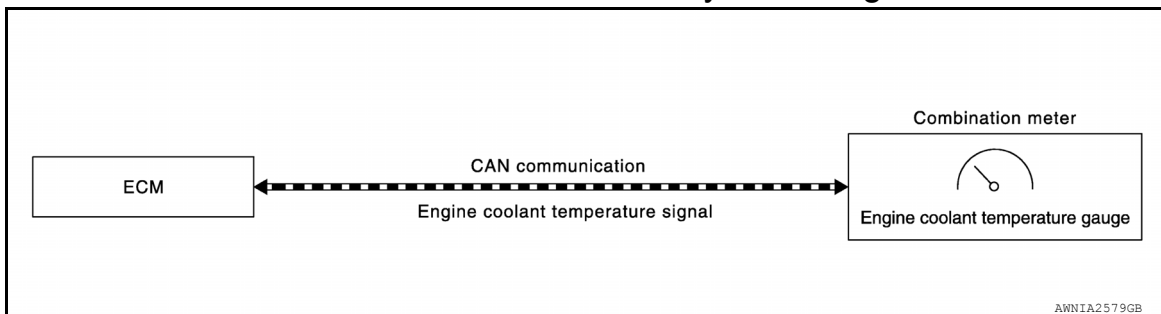

## ENGINE COOLANT TEMPERATURE GAUGE : System Description

INFOID:000000007985678

The engine coolant temperature sensor sends an engine coolant temperature signal to the ECM. The ECM provides an engine coolant temperature signal to the combination meter via CAN communication lines.

The engine coolant temperature gauge indicates the engine coolant temperature.

## FUEL GAUGE

### FUEL GAUGE : System Diagram

INFOID:000000007985681

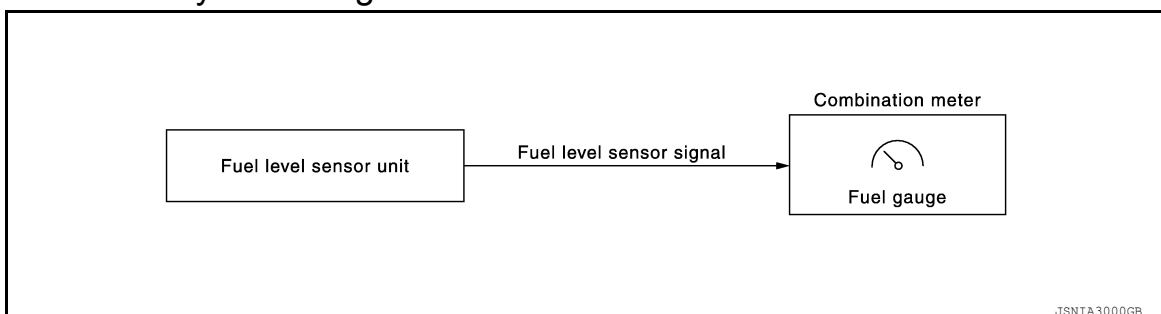

## FUEL GAUGE : System Description

INFOID:000000007985682

The fuel level sensor unit sends a variable resistor signal to the combination meter. The fuel gauge indicates the approximate fuel level in the fuel tank.

## MASTER WARNING LAMP

# SYSTEM

< SYSTEM DESCRIPTION >

## MASTER WARNING LAMP : System Diagram

INFOID:000000008659896

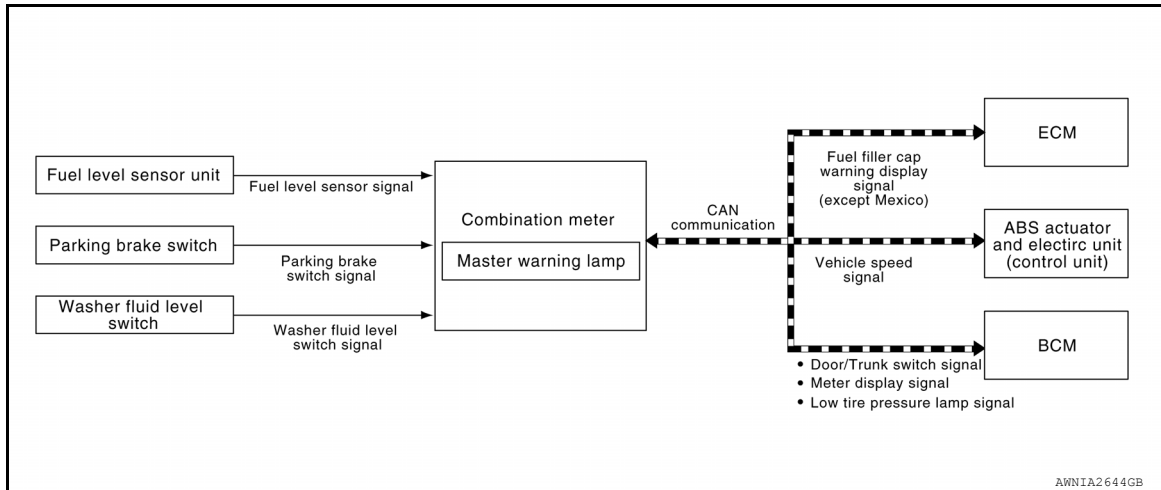

## MASTER WARNING LAMP : System Description

INFOID:000000008659897

When receiving a signal from each unit, switch, or sensor, the combination meter turns ON/OFF the master warning lamp in synchronization with the following warnings on the information display:

- Door/trunk open warning
- Parking brake release warning
- Low fuel warning
- Low washer fluid warning
- NO KEY warning
- Low tire pressure warning
- Fuel filler cap warning (except Mexico)

## METER ILLUMINATION CONTROL

### METER ILLUMINATION CONTROL : System Diagram

INFOID:000000008659898

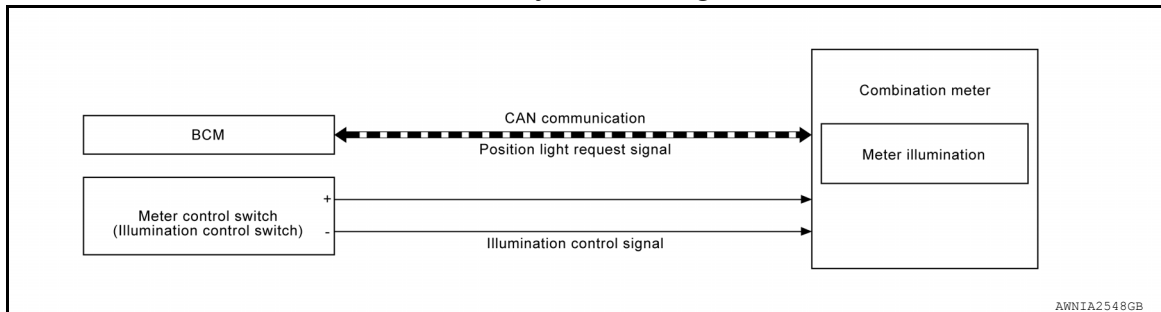

### METER ILLUMINATION CONTROL : System Description

INFOID:000000008659899

#### METER ILLUMINATION CONTROL

Meter illumination control adjusts the brightness of the combination meter illumination using the meter control switch (illumination control switch).

#### METER ILLUMINATION CONTROL FUNCTION

The operation of the illumination control switch changes brightness of the meter illumination.

Meter illumination	The number of adjustable steps
Daytime	22 steps
Nighttime	22 steps

## METER EFFECT FUNCTION

A  
B  
C  
D  
E  
F  
G  
H  
I  
J  
K  
L  
M

MWI

O  
P

# SYSTEM

## < SYSTEM DESCRIPTION >

### METER EFFECT FUNCTION : System Diagram

INFOID:00000008718321

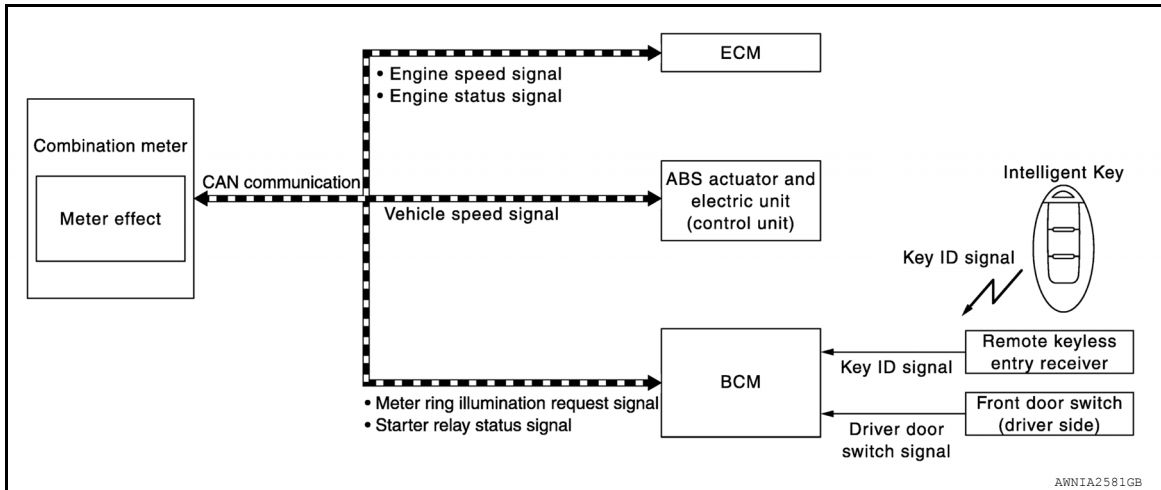

### METER EFFECT FUNCTION : System Description

INFOID:00000008718322

#### ENGINE-START EFFECT FUNCTION

When recognizing an engine start, the combination meter controls the following items for producing the effect:

- Speedometer
- Tachometer
- Engine coolant temperature gauge
- Fuel gauge
- Meter illumination

#### Meter and Illumination Operations During Engine-start Effect

The combination meter controls the following items during the engine-start effect.

Control item		Operation
Speedometer		Sweeps the pointer.
Tachometer		Sweeps the pointer.
Engine coolant temperature gauge		Stops the pointer.
Fuel gauge		Stops the pointer.
Meter illumination	Pointers	Turns on the illumination at the effect level.
	Information display	Turns on the illumination at the normal brightness level.
	Other than those above	Increases the brightness to the effect level in stages.

#### NOTE:

The pointers are stopped and illumination is turned off while cranking the engine.

#### Engine Start Judgement

The combination meter judges “engine-start” and activates the engine-start effect only once when the following operational conditions are all satisfied.

Condition	
Ignition switch	ON position
Vehicle speed	Less than 1 km/h (0.6 MPH)
Engine state	Other than the time of cranking the engine
	500 rpm or more
Information display (SETTING)	The setting of “EFFECT” is “ON.”

#### NOTE:

# SYSTEM

## < SYSTEM DESCRIPTION >

Engine-start effect exits when any of the above operational conditions is cancelled during the engine-start effect.

## INFORMATION DISPLAY

### INFORMATION DISPLAY : System Diagram

INFOID:000000007985697

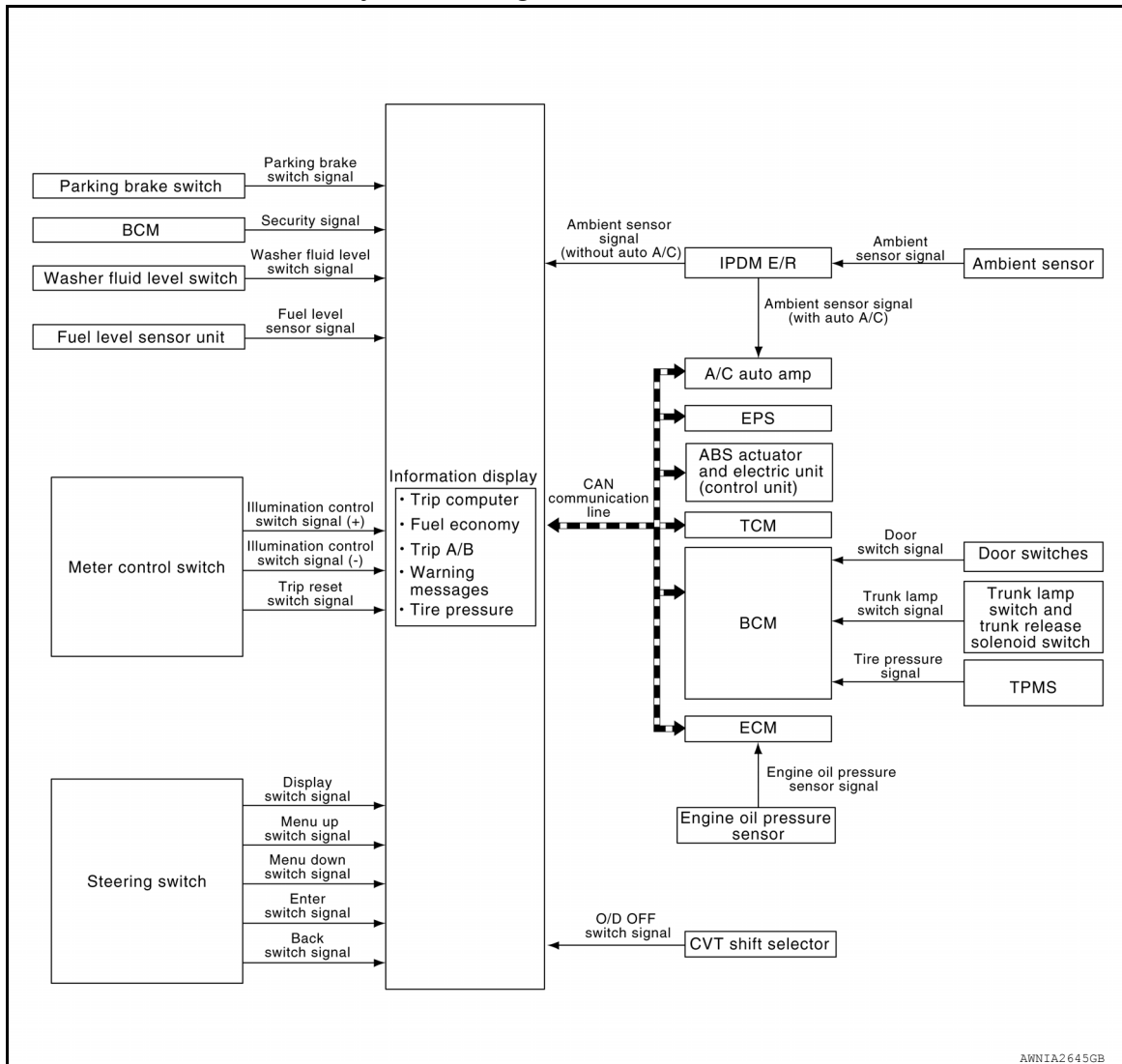

### INFORMATION DISPLAY : System Description

INFOID:000000007985698

#### FUNCTION

The information display can indicate the following items.

- Outside air temperature
- Trip computer
- Intelligent Key operation information
- CVT shift position indicator
- Odometer
- Warning/Indication messages (Door/trunk open, low oil pressure, CVT, low fuel, low washer fluid, I-Key, release parking brake, low tire pressure and loose fuel cap (except Mexico)).

#### OUTSIDE AIR TEMPERATURE INDICATION

Displays the ambient temperature based on signals received from:

- The A/C auto amp. via CAN communication (with auto A/C).
- The IPDM E/R (without auto A/C).

#### LOOSE FUEL CAP (EXCEPT MEXICO)

A  
B  
C  
D  
E  
F  
G  
H  
I  
J  
K  
L  
M

O  
P

# SYSTEM

## < SYSTEM DESCRIPTION >

The LOOSE FUEL CAP message will display in the information display when the fuel-filler cap is not tightened correctly. The message will turn off as soon as the ECM detects the fuel-filler cap is properly tightened. The ECM provides a loose fuel cap signal to the combination meter via CAN communication.

### LOW TIRE PRESSURE WARNING

This warning appears when the BCM detects low inflation pressure or a system malfunction. The BCM sends a signal to the combination meter via CAN communication to illuminate the low tire pressure warning lamp. In addition, a warning message will be displayed in the vehicle information display.

### DOOR OPEN WARNING

This warning appears when the ignition switch is ON and the door is open. The BCM receives a door switch signal from the door open door switch. The BCM sends the door switch signal to the combination meter via CAN communication lines.

### TRUNK OPEN WARNING

This warning appears when the ignition switch is ON and the trunk is opened. The BCM receives a trunk lamp switch signal from the trunk lamp switch. The BCM sends the trunk lamp switch signal to the combination meter via CAN communication.

### LOW FUEL WARNING

This warning appears when the fuel level in the fuel tank is less than approximately 4 US gal (15 L, 3.3 Imp gal). A variable resistor signal is supplied to the combination meter from the fuel level sensor unit to determine the amount of fuel in the fuel tank.

### LOW WINDSHIELD WASHER FLUID WARNING

When the windshield washer fluid level is low, the washer fluid level switch provides a ground signal to the combination meter and the warning is displayed. Once fluid is added, the switch opens and the warning is no longer displayed.

### RELEASE PARKING BRAKE WARNING

When the parking brake is applied, the parking brake switch provides a ground signal to the combination meter. When the vehicle speed is greater than 4 MPH (7 km/h), the message is displayed and the warning chime sounds.

### SHIFT POSITION INDICATOR

Displays the position of the shift selector based on signals received from TCM via CAN communication.

### LOW OIL PRESSURE WARNING

The low oil pressure warning appears in the information display when the combination meter receives a low engine oil pressure signal from the ECM via CAN communication.

### WARNING CHECK INDICATION

The combination meter can cause an interrupt on the information display to indicate a warning, based on signals received from each unit and switch.

Refer to Owner's Manual for additional information display items.

## COMPASS

### COMPASS : Description

INFOID:000000007985701

#### DESCRIPTION

With the ignition switch in the ON position, and the mode (N) switch ON, the compass display will indicate the direction the vehicle is heading.

Vehicle direction is displayed as follows:

- N: north
- E: east
- S: south
- W: west

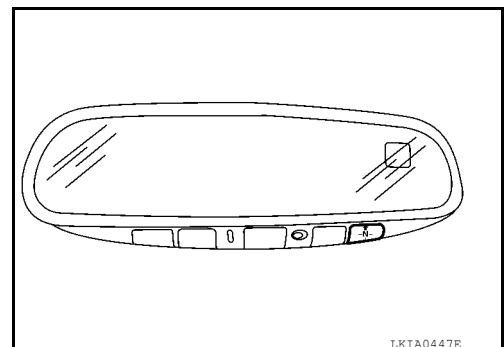

LKIA0447E



# SYSTEM

## < SYSTEM DESCRIPTION >

### ZONE VARIATION SETTING PROCEDURE

The difference between magnetic north and geographical north can sometimes be great enough to cause false compass readings. This difference is known as variance. In order for the compass to operate properly (accurately) in a particular zone, the zone variation must be calibrated using the following procedure.

Zone Variation Chart

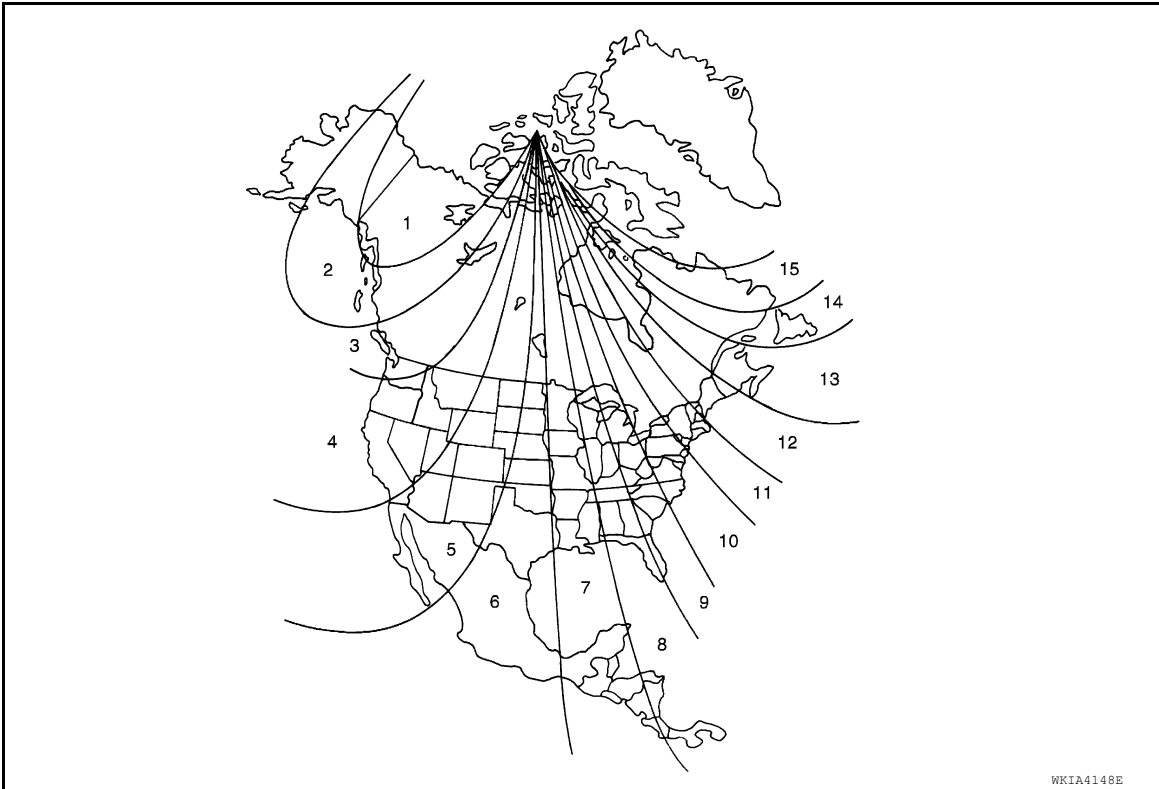

1. Determine your location on the zone map.
2. Turn the ignition switch to the ON position.
3. Press and hold the mode (N) switch until the current zone number is displayed.
4. Press the mode (N) switch repeatedly until the desired zone number appears in the display.

Once the desired zone number is displayed, stop pressing the mode (N) switch and the display will show a compass direction after a few seconds.

#### **NOTE:**

Use zone number 5 for Hawaii.

### CALIBRATION PROCEDURE

The compass display is equipped with an automatic correction function. If the compass display reads "C" or the direction is not shown correctly, perform the correction procedure below.

1. Press and hold the mode (N) switch until the display reads "C".
2. Drive the vehicle slowly in a circle, in an open, safe place. The initial calibration is completed in about three turns.

#### **NOTE:**

In places where the terrestrial magnetism is extremely disturbed, the initial correction may start automatically.

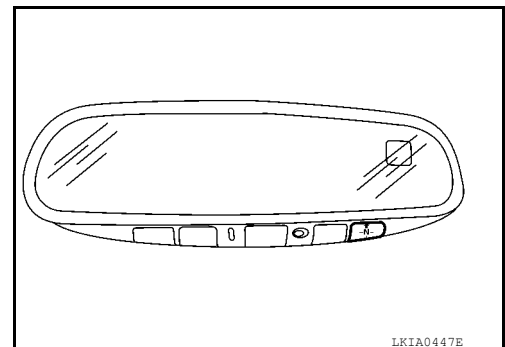

# DIAGNOSIS SYSTEM (METER)

< SYSTEM DESCRIPTION >

## DIAGNOSIS SYSTEM (METER)

### Description

INFOID:000000008659086

#### COMBINATION METER SELF-DIAGNOSIS MODE

The following meter functions can be checked during Combination Meter Self-Diagnosis Mode:

- Pointer sweep of speedometer, tachometer and gauges.
- Illumination of all LCD segments and color patterns for meter displays.
- Illumination of all lamps/LEDs that are controlled by the combination meter (regardless of switch status).

#### STARTING COMBINATION METER SELF-DIAGNOSIS MODE

##### NOTE:

- Check combination meter power supply and ground circuits if self-diagnosis mode does not start. Refer to [MWI-57, "COMBINATION METER : Diagnosis Procedure"](#). Replace combination meter if power supply and ground circuits are found to be normal and self-diagnosis mode does not start. Refer to [MWI-81, "Removal and Installation"](#).
- Combination meter self-diagnosis mode will function with the ignition switch in ON. Combination meter self-diagnosis mode will exit upon turning the ignition switch to OFF.

#### How to Initiate Self-Diagnosis Mode

1. Press and hold the trip reset switch while turning the ignition switch ON. After 2 seconds release trip reset switch, then press the trip reset switch 3 times within 7 seconds after the ignition switch is turned ON.
2. When the diagnosis function is activated, the meter illuminates all of the following:
  - Warning lights/indicators.
  - Meter assembly.
  - Information display color bars red, green, blue and white (1).
  - Odometer, trip A/B odometers and CVT indicator LCD display segments (2).
3. Pressing and holding the trip reset switch performs the pointer sweep test.

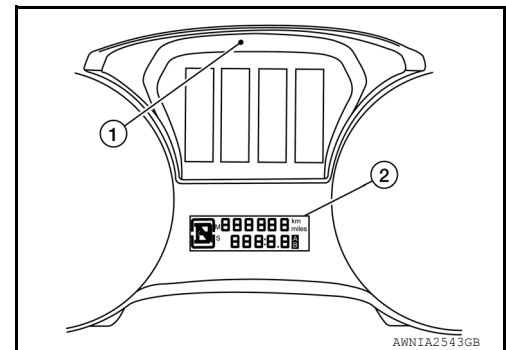

### CONSULT Function (METER/M&A)

INFOID:000000008659087

#### APPLICATION ITEMS

CONSULT can display each diagnostic item using the diagnostic test modes shown.

METER/M&A Diagnosis mode	Description
SELF DIAGNOSTIC RESULT	Displays combination meter self-diagnosis results.
DATA MONITOR	Displays combination meter input/output data in real time.
WARNING HISTORY	Lighting history of the warning lamp and indicator lamp can be checked.
CAN DIAG SUPPORT MNTR	The result of transmit/receive diagnosis of CAN communication can be read.

#### SELF DIAG RESULT

Refer to [MWI-27, "DTC Index"](#).

#### DATA MONITOR

##### Display Item List

## DIAGNOSIS SYSTEM (METER)

### < SYSTEM DESCRIPTION >

X: Applicable

Display item [Unit]	MAIN SIGNALS	Description	A
SPEED METER [mph or km/h]	X	Displays the value of vehicle speed signal.	B
SPEED OUTPUT [mph or km/h]	X	Vehicle speed signal value transmitted to other units via CAN communication.	C
ODO OUTPUT [mph or km/h]		Odometer signal value transmitted to other units via CAN communication.	D
TACHO METER [rpm]	X	Value of the engine speed signal received from ECM via CAN communication.	E
FUEL METER [L]	X	Fuel level indicated on combination meter.	F
W TEMP METER [°F] or [°C]	X	Displays the value of engine coolant temperature signal, which is input from ECM.	G
ABS W/L [On/Off]		Displays [ON/OFF] condition of ABS warning indicator.	H
VDC/TCS IND [ON/OFF]		Displays [ON/OFF] condition of VDC OFF indicator lamp.	I
SLIP IND [ON/OFF]		Displays [ON/OFF] condition of SLIP indicator lamp.	J
BRAKE W/L [ON/OFF]		Displays [ON/OFF] condition of brake warning indicator.	K
DOOR W/L [ON/OFF]		Displays [ON/OFF] condition of door warning message.	L
TRUNK/GLAS-H [On/Off]		Displays [ON/OFF] condition of trunk warning message.	M
HI-BEAM IND [ON/OFF]		Displays [ON/OFF] condition of high beam indicator.	MWI
TURN IND [On/Off]		Displays [ON/OFF] condition of turn indicator.	O
FR FOG IND [On/Off]		Displays [ON/OFF] condition of front fog lamp indicator.	P
LIGHT IND [On/Off]		Displays [ON/OFF] condition of light indicator.	
OIL W/L [ON/OFF]		Displays [ON/OFF] condition of low oil pressure warning message.	
MIL [ON/OFF]		Displays [ON/OFF] condition of malfunction indicator.	
CRUISE IND [Off]		Displays [ON/OFF] condition of CRUISE indicator in the information display.	
CVT IND [Off]		Displays [ON/OFF] condition of CVT indicator in the information display.	
SET IND [On/Off]		Displays [ON/OFF] condition of SET indicator in the information display.	
O/D OFF IND [ON/OFF]		Displays [ON/OFF] condition of O/D OFF indicator.	
FUEL W/L [On/Off]		Displays [ON/OFF] condition of low-fuel warning message.	
WASHER W/L [On/Off]		Displays [ON/OFF] condition of low washer fluid warning message.	
KEY G/Y W/L [On/Off]		Displays [ON/OFF] condition of key green warning lamp.	

## DIAGNOSIS SYSTEM (METER)

### < SYSTEM DESCRIPTION >

Display item [Unit]	MAIN SIGNALS	Description
EPS W/L [On/Off]		Displays [ON/OFF] condition of EPS warning indicator.
LCD		Displays the value of Intelligent Key system message indication.
ACC SET SPEED [Off, km/h or mph]		Displays OFF or SET vehicle speed status in the information display.
ACC UNIT [On/Off]		Displays [ON/OFF] condition of display unit in the information display.
SHIFT IND [P, R, N, D, L]		Displays [P, R, N, D, L] shift selector position.
FUEL CAP W/L [On/Off]		Displays [ON/OFF] condition of loose fuel cap warning message.
O/D OFF SW [ON/OFF]		Displays [ON/OFF] condition of O/D OFF switch.
M RANGE SW [On/Off]		Displays [ON/OFF] condition of manual mode switch.
NM RANGE SW [On/Off]		Displays [ON/OFF] condition of non-manual mode switch.
AT SFT UP SW [On/Off]		Displays [ON/OFF] condition of manual mode shift up switch.
AT SFT DWN SW [On/Off]		Displays [ON/OFF] condition of manual mode shift down switch.
ST SFT UP SW [On/Off]		Displays [ON/OFF] condition of paddle shift up switch.
ST SFT DWN SW [On/Off]		Displays [ON/OFF] condition of paddle shift down switch.
PKB SW [On/Off]		Displays [ON/OFF] condition of parking brake switch.
BUCKLE SW [ON/OFF]		Status of seat belt buckle switch (LH).
BRAKE OIL SW [On/Off]		Displays [ON/OFF] condition of brake fluid level switch.
PASS BUCKLE SW [ON/OFF]		Status of passenger seat belt buckle switch (RH).
DISTANCE [Mi] or [km]		Displays distance to empty.
OUTSIDE TEMP [°F or °C]		Displays the ambient air temperature which is input from the ambient sensor.
BUZZER [On/Off]	X	Buzzer status (in the combination meter) is detected from the buzzer output signal received from each unit via CAN communication and the warning output condition of the combination meter.
BSW IND [ON/OFF]		Displays [ON/OFF] condition of BSW warning indicator message in the information display.
LDW IND [ON/OFF]		Displays [ON/OFF] condition of LDW warning indicator message in the information display.
TPMS MALF [ON/OFF]		Displays [ON/OFF] condition of TPMS warning indicator.

### SPECIAL FUNCTION

#### Special menu

Display item	Description
W/L ON HISTORY	Lighting history of warning lamp and indicator lamp can be checked.

## DIAGNOSIS SYSTEM (METER)

### < SYSTEM DESCRIPTION >

---

#### W/L ON HISTORY

- “W/L ON HISTORY” indicates the “TIME” when the warning/ indicator lamp is turned on. A
- The “TIME” above is:
  - 0: The condition that the warning/indicator lamp has been turned on 1 or more times after starting the engine and waiting for 30 seconds. B
  - 1 - 39: The number of times the engine was restarted after the 0 condition. B
  - NO W/L ON HISTORY: No warning/indicator lamp history is stored.

#### **NOTE:**

- W/L ON HISTORY is not stored for approximately 30 seconds after the engine starts. C
- Brake warning lamp does not store any history when the parking brake is applied or the brake fluid level gets low. D

D

E

F

G

H

I

J

K

L

M

MWI

O

P

# COMBINATION METER

< ECU DIAGNOSIS INFORMATION >

## ECU DIAGNOSIS INFORMATION

### COMBINATION METER

Reference Value

INFOID:000000008659088

#### VALUES ON THE DIAGNOSIS TOOL

Monitor Item	Condition		Value/Status
SPEED METER [mph or km/h]	Ignition switch ON	While driving	Input value of vehicle speed signal (CAN communication signal)
SPEED OUTPUT [mph or km/h]	Ignition switch ON	While driving	Output value of vehicle speed signal (CAN communication signal)
ODO OUTPUT [mph or km/h]	Ignition switch ON	—	Output value of odometer signal (CAN communication signal)
TACHO METER [rpm]	Ignition switch ON	Engine running	Input value of engine speed signal (CAN communication signal)
FUEL METER [L]	Ignition switch ON	—	Input value of fuel level sensor signal
W TEMP METER [°F] or [°C]	Ignition switch ON	—	Input value of engine coolant temperature signal (CAN communication signal)
ABS W/L	Ignition switch ON	ABS warning lamp ON	On
		ABS warning lamp OFF	Off
VDC/TCS IND	Ignition switch ON	VDC OFF indicator lamp ON	On
		VDC OFF indicator lamp OFF	Off
SLIP IND	Ignition switch ON	VDC warning lamp ON	On
		VDC warning lamp OFF	Off
BRAKE W/L	Ignition switch ON	Brake warning lamp ON	On
		Brake warning lamp OFF	Off
DOOR W/L	Ignition switch ON	Door open warning ON	On
		Other than the above	Off
TRUNK/GLAS-H	Ignition switch ON	Trunk open warning ON	On
		Trunk open warning OFF	Off
HI-BEAM IND	Ignition switch ON	High beam indicator lamp ON	On
		High beam indicator lamp OFF	Off
TURN IND	Ignition switch ON	Turn signal indicator lamp ON	On
		Turn signal indicator lamp OFF	Off
LIGHT IND	Ignition switch ON	Tail lamp indicator lamp ON	On
		Tail lamp indicator lamp OFF	Off
FR FOG IND	Ignition switch ON	Front fog lamp indicator lamp ON	On
		Front fog lamp indicator lamp OFF	Off
OIL W/L	Ignition switch ON	Oil pressure warning	On
		Oil pressure warning	Off
MIL	Ignition switch ON	Malfunction indicator lamp ON	On
		Malfunction indicator lamp OFF	Off
CRUISE IND	Ignition switch ON	CRUISE indicator ON	On
		CRUISE indicator OFF	Off

# COMBINATION METER

## < ECU DIAGNOSIS INFORMATION >

Monitor Item	Condition		Value/Status	
CVT IND	Ignition switch ON	CVT indicator ON	On	A
		CVT indicator OFF	Off	
SET IND	Ignition switch ON	SET indicator ON	On	B
		SET indicator OFF	Off	
O/D OFF IND	Ignition switch ON	O/D OFF indicator ON	On	C
		O/D OFF indicator OFF	Off	
FUEL W/L	Ignition switch ON	During low fuel level indication	On	D
		Except during low fuel level indication	Off	
WASHER W/L	Ignition switch ON	Low washer fluid warning indication	On	E
		Except during low washer fluid warning indication	Off	
KEY G/Y W/L	Ignition switch ON	During Intelligent Key system malfunction indication	On	F
		Other than the above	Off	
EPS W/L	Ignition switch ON	EPS warning lamp ON	On	G
		EPS warning lamp OFF	Off	
LCD	Ignition switch ACC	During engine start information indication	B&P	
ACC SET SPEED	Ignition switch ON	During set vehicle speed indicator not displayed	Off	H
		During set vehicle speed indicator displayed	Indicates the set vehicle speed	
ACC UNIT	Ignition switch ON	Set vehicle speed indicator unit display ON	On	I
		Set vehicle speed indicator unit display OFF	Off	
SHIFT IND	Ignition switch ON	Position of shift selector	[P, R, N, D, L]	J
FUEL CAP W/L	Ignition switch ON	Fuel filler cap warning display ON	On	K
		Fuel filler cap warning display OFF	Off	
O/D OFF SW	Ignition switch ON	Overdrive control switch ON	On	L
		Overdrive control switch OFF	Off	
M RANGE SW	Ignition switch ON	Shift selector in manual mode position	On	M
		Other than the above	Off	
NM RANGE SW	Ignition switch ON	Shift selector in manual mode position	Off	
		Other than the above	On	
AT SFT UP SW	Ignition switch ON	Shift selector operated in the up position	On	MWI
		Other than the above	Off	
AT SFT DWN SW	Ignition switch ON	Shift selector operated in the down position	On	
		Other than the above	Off	
ST SFT UP SW	Ignition switch ON	Paddle shifter operated in up position	On	O
		Shift selector is in non manual mode up position	Off	
ST SFT DWN SW	Ignition switch ON	Paddle shifter operated in down position	On	P
		Other than the above	Off	
PKB SW	Ignition switch ON	Parking brake switch ON	On	
		Parking brake switch OFF	Off	
BUCKLE SW	Ignition switch ON	Driver seat belt not fastened	On	
		Driver seat belt fastened	Off	

# COMBINATION METER

## < ECU DIAGNOSIS INFORMATION >

Monitor Item	Condition		Value/Status
EPS W/L	Ignition switch ON	EPS warning lamp ON	On
		EPS warning lamp OFF	Off
BRAKE OIL SW	Ignition switch ON	Brake fluid level switch ON	On
		Brake fluid level switch OFF	Off
PASS BUCKLE SW	Ignition switch ON	Passenger seat belt not fastened	On
		Passenger seat belt fastened	Off
DISTANCE [mile] or [km]	Ignition switch ON	—	Distance to empty
OUTSIDE TEMP [°F] or [°C]	Ignition switch ON	—	Displays the ambient air temperature which is input from the ambient sensor
BUZZER	Ignition switch ON	Buzzer ON	On
		Buzzer OFF	Off
TPMS MALF	Ignition switch ON	Low tire pressure warning lamp ON	On
		Low tire pressure warning lamp OFF	Off
BSW IND	Ignition switch ON	BSW indicator ON	On
		BSW indicator OFF	Off
LDW IND	Ignition switch ON	LDW indicator ON	On
		LDW indicator OFF	Off

## TERMINAL LAYOUT

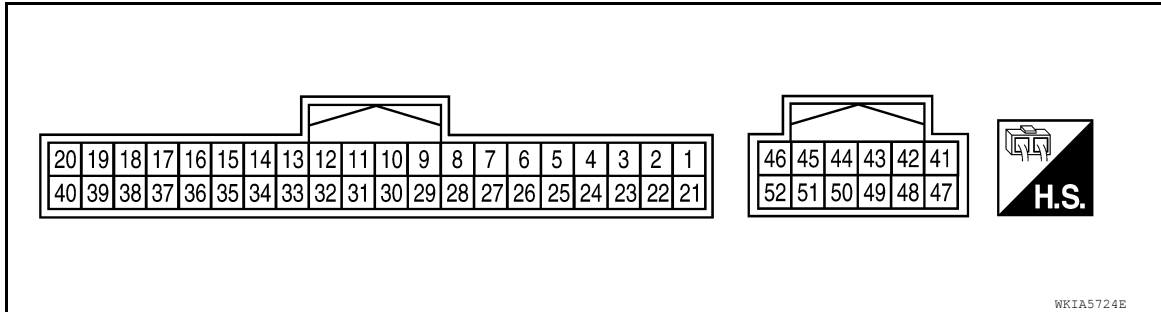

## PHYSICAL VALUES

Terminal No. (Wire color)		Description		Condition		Value (Approx.)
+	-	Signal name	Input/ Output			
1 (B)	Ground	Ground	Input	Ignition switch OFF	—	Battery voltage
2 (B)	Ground	Ground	Input	Ignition switch ON	—	Battery voltage
3 (P)	Ground	Steering switch input 1	—	—	—	—
4 (R)	Ground	Steering switch input 2	—	—	—	—
5 (P)	Ground	ACC	—	Ignition switch ON	Ignition switch ACC or ON power supply	Battery voltage



# COMBINATION METER

## < ECU DIAGNOSIS INFORMATION >

Terminal No. (Wire color)		Description		Condition		Value (Approx.)	
+	-	Signal name	Input/ Output				
6 (G)	Ground	Security signal	Input	Ignition switch ON	Security indicator ON	0 V	A
					Security indicator OFF	12 V	B
7 (R)	Ground	Air bag signal	Input	Ignition switch ON	Air bag warning lamp ON	—	C
					Air bag warning lamp OFF	—	D
8 (GR)	Ground	Passenger seat belt warn- ing signal	Input	Ignition switch ON	Fastened	12 V	E
					Unfastened	0 V	F
9 (V)	Ground	Seat belt buckle switch sig- nal (driver seat)	Input	Ignition switch ON	Fastened	12 V	G
					Unfastened	0 V	H
11 (R)	Ground	Alternator signal	Input	Ignition switch ON	Charge warning lamp ON	2 V	I
					Charge warning lamp OFF	Battery voltage	J
12 (G)	Ground	Parking brake switch signal	Input	Ignition switch ON	Parking brake applied	0 V	K
					Parking brake released	12 V	L
18 (BR)	Ground	AC PD cut	Input	Ignition switch ON	Signal ON	0 V	M
					Signal OFF	5 V	MWI
21 (BR)	—	Ignition	—	Ignition switch ON or START	—	12 V	O
22 (G)	—	Battery power supply	—	Ignition switch OFF	—	Battery voltage	P
23 (GR)	Ground	Illumination control output signal	—	Ignition switch ON	—	0 V	
24 (W)	Ground	Steering switch ground	—	Ignition switch ON	—	0 V	
25 (BR)	Ground	Brake fluid level switch	Input	Ignition switch ON	Brake fluid level low	0 V	
					Brake fluid level normal	Battery voltage	
26 (R)	Ground	Fuel level sensor ground	—	Ignition switch ON	—	0 V	
27 (W)	Ground	Fuel level sensor signal	—	—	—	—	
30 (L)	Ground	Ambient sensor signal (without auto A/C)	Input	Ignition switch ON	—	0-5 V (based on ambient temperature)	
31 (W)	Ground	Ambient sensor ground (without auto A/C)	Input	Ignition switch ON	—	0 V	

# COMBINATION METER

## < ECU DIAGNOSIS INFORMATION >

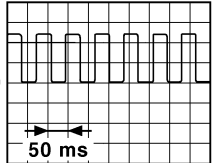
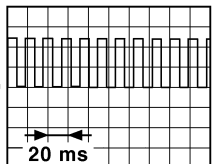
Terminal No. (Wire color)		Description		Condition		Value (Approx.)
+	-	Signal name	Input/ Output			
33 (BR)	Ground	Vehicle speed signal (2-pulse)	Output	Ignition switch ON	Speedometer operated [When vehicle speed is ap- prox. 25 MPH (40 km/h)]	<b>NOTE:</b> The maximum voltage varies de- pending on the specification (destination unit).   <small>JSNIA0015GB</small>
34 (G)	Ground	Vehicle speed signal (8-pulse)	Output	Ignition switch ON	Speedometer operated [When vehicle speed is ap- prox. 25 MPH (40 km/h)]	<b>NOTE:</b> The maximum voltage varies de- pending on the specification (destination unit).   <small>JSNIA0012GB</small>
36 (LG)	Ground	M-CAN L	—	—	—	—
37 (SB)	Ground	M-CAN H	—	—	—	—
38 (P)	Ground	CAN-L	—	—	—	—
39 (L)	Ground	CAN-H	—	—	—	—
41 (V)	Ground	Trip/Reset signal	Input	Ignition switch ON	Trip/Reset switch is pressed	0 V
					Other than the above	5 V
42 (SB)	Ground	Illumination down switch signal	Input	Ignition switch ON	Illumination switch down is pressed	0 V
					Other than the above	5 V
47 (Y)	Ground	Illumination up switch sig- nal	Input	Ignition switch ON	Illumination switch up is pressed	0 V
					Other than the above	5 V
48 (G)	Ground	Meter control switch ground	—	—	—	—
49 (BR)	Ground	Washer fluid level switch signal	Input	Ignition switch ON	Washer fluid level switch ON	0 V
					Washer fluid level switch OFF	5 V
50 (W)	Ground	Paddle shifter up switch signal	Input	Ignition switch ON	Paddle shift up operated	12 V
					Other than the above	0 V
51 (R)	Ground	Paddle shifter down switch signal	Input	Ignition switch ON	Paddle shift down operated	12 V
					Other than the above	0 V
52 (P)	Ground	O/D OFF/SPORT switch	Input	Ignition switch ON	O/D OFF switch pressed	0 V
					Other than the above	5 V

# COMBINATION METER

< ECU DIAGNOSIS INFORMATION >

## Fail-Safe

INFOID:000000008659089

### FAIL-SAFE

The combination meter activates the fail-safe control if CAN communication with each unit is malfunctioning.

Function		Specifications
Speedometer		Reset to zero by suspending communication.
Tachometer		
Engine coolant temperature gauge		
Illumination control		When suspending communication, changes to nighttime mode.
Information display	Odo/trip meter	An indicated value is maintained at communications blackout.
	Shift position indicator	The display turns OFF by suspending communication.
	Warning messages	The display turns OFF by suspending communication.
Buzzer		The buzzer turns OFF by suspending communication.
Warning lamp/indicator lamp	ABS warning lamp	The lamp turns ON by suspending communication.
	O/D OFF indicator lamp	
	Slip indicator lamp	
	Brake warning lamp	
	Malfunction indicator lamp	
	VDC OFF indicator lamp	
	EPS warning lamp	
	Low tire pressure warning lamp	The lamp blinking caused by suspending communication.
	High beam indicator lamp	The lamp turns OFF by suspending communication.
	Turn signal indicator lamp	
	Master warning lamp	
	Front lamp indicator lamp	
	Lane departure warning	
	Tail lamp indicator lamp	
	Air bag warning lamp	The lamp turns off when disconnected.
Charge warning lamp		
Seat belt warning lamp		
Security indicator lamp		

## DTC Index

INFOID:000000008659090

Display contents of CONSULT	Diagnostic item is detected when...	Refer to
CAN COMM CIRCUIT [U1000]	When combination meter is not transmitting or receiving CAN communication signal for 2 seconds or more.	<a href="#">MWI-52</a>
CONTROL UNIT (CAN) [U1010]	When detecting error during the initial diagnosis of the CAN controller of combination meter.	<a href="#">MWI-53</a>
VEHICLE SPEED CIRC [B2205]	The abnormal vehicle speed signal is input from the ABS actuator and electric unit (control unit) for 2 seconds or more.	<a href="#">MWI-54</a>
TACHO METER [B2267]	If ECM continuously transmits abnormal engine speed signals for 2 seconds or more.	<a href="#">MWI-55</a>
WATER TEMP METER [B2268]	If ECM continuously transmits abnormal engine coolant temperature signals for 60 seconds or more.	<a href="#">MWI-56</a>

# BCM, IPDM E/R

< ECU DIAGNOSIS INFORMATION >

## BCM, IPDM E/R

### List of ECU Reference

INFOID:000000008659091

ECU	Reference
BCM	<a href="#">BCS-28. "Reference Value"</a>
	<a href="#">BCS-47. "Fail Safe"</a>
	<a href="#">BCS-47. "DTC Inspection Priority Chart"</a>
	<a href="#">BCS-49. "DTC Index"</a>
IPDM E/R	<a href="#">PCS-12. "Reference Value"</a>
	<a href="#">PCS-19. "Fail Safe"</a>
	<a href="#">PCS-20. "DTC Index"</a>

COMPASS

< WIRING DIAGRAM >

WIRING DIAGRAM

COMPASS

Wiring Diagram

INFOID:000000007985746

A  
B  
C  
D  
E  
F  
G  
H  
I  
J  
K  
L  
M  
O  
P

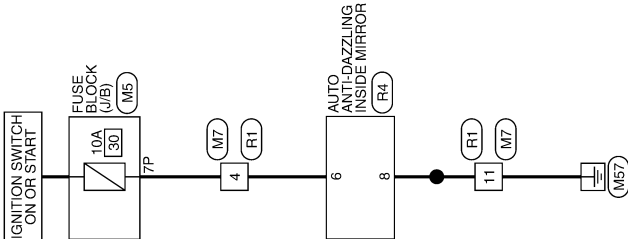

COMPASS

MWI

ABNWA1464GB

## COMPASS CONNECTORS

Connector No.	M5
Connector Name	FUSE BLOCK (J/B)
Connector Color	WHITE



Terminal No.	Color of Wire	Signal Name
7P	G	-

Connector No.	M7
Connector Name	WIRE TO WIRE
Connector Color	WHITE

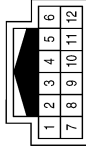

Terminal No.	Color of Wire	Signal Name
4	G	-
11	GR	-

Connector No.	R1
Connector Name	WIRE TO WIRE
Connector Color	WHITE

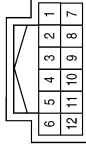

Terminal No.	Color of Wire	Signal Name
4	B/R	-
11	GR	-

Connector No.	R4
Connector Name	AUTO ANTI-DAZZLING INSIDE MIRROR
Connector Color	BLACK

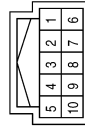

Terminal No.	Color of Wire	Signal Name
6	B/R	IGN
8	B	GND

ABNIA3651GB

# METER

< WIRING DIAGRAM >

## METER

### Wiring Diagram

INFOID:000000007985748

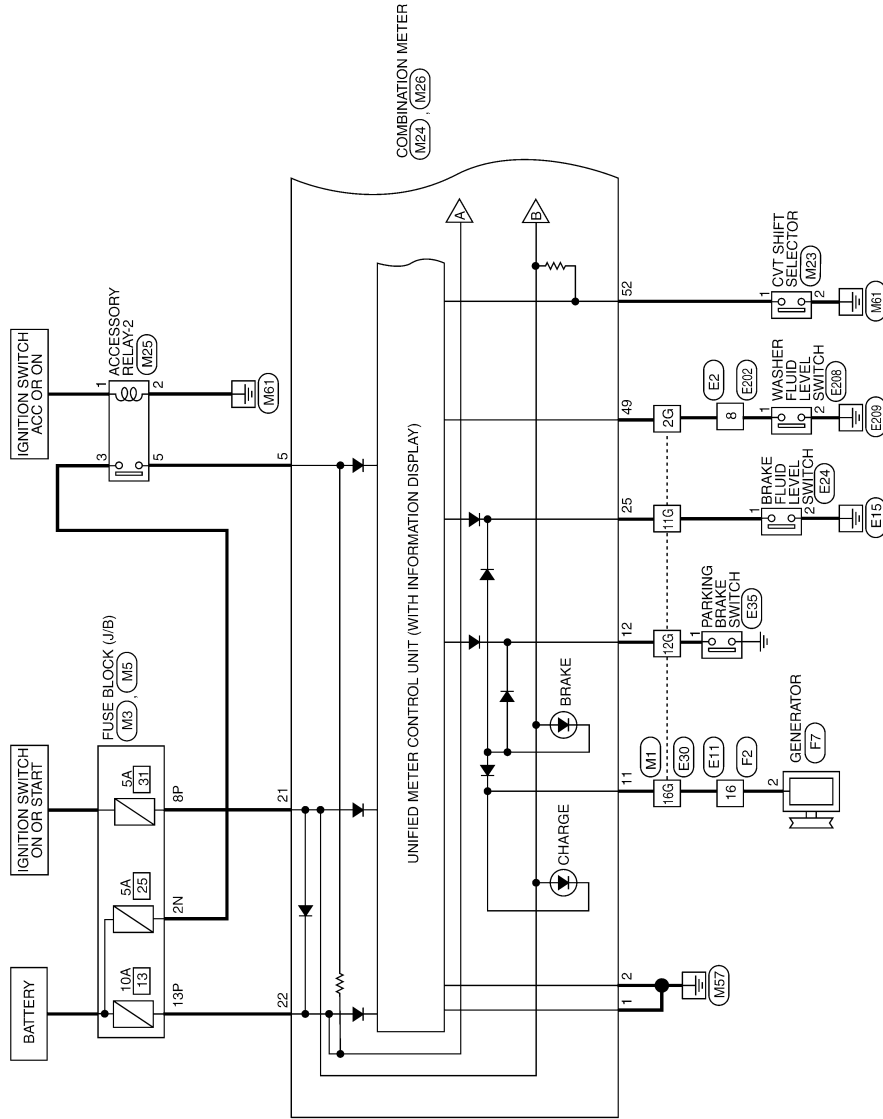

METER

A  
B  
C  
D  
E  
F  
G  
H  
I  
J  
K  
L  
M  
N  
O  
P

MWI

ABNWA1459GB







# METER

< WIRING DIAGRAM >

- ◁AA> : WITH AUTO A/C
- ◁FL> : WITH FRONT FOG LAMPS
- ◁MA> : WITHOUT AUTO A/C

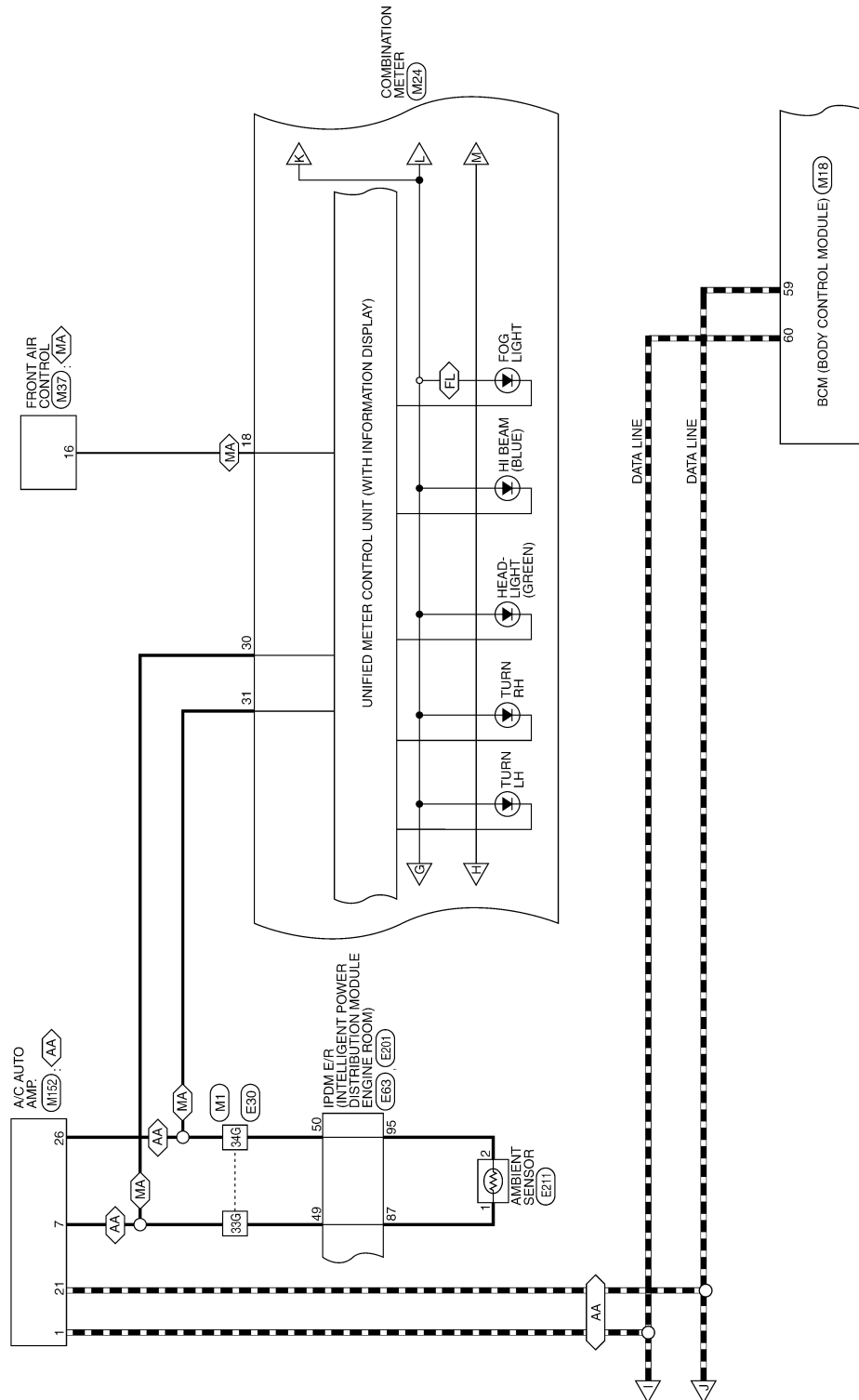

ABNWA1462GB

# METER

< WIRING DIAGRAM >

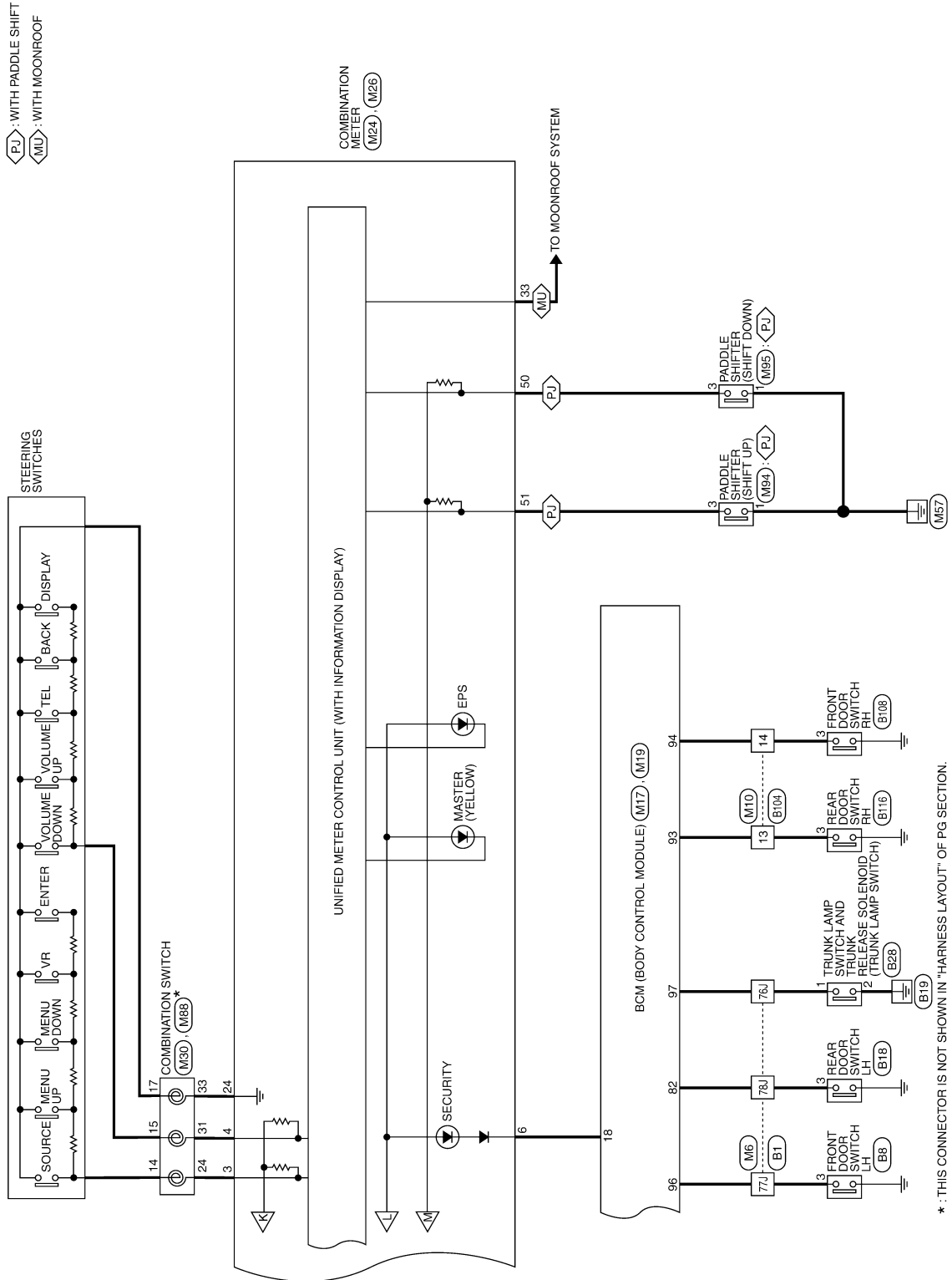

ABNWA1463GB

A  
B  
C  
D  
E  
F  
G  
H  
I  
J  
K  
L  
M  
N  
O  
P



METER CONNECTORS

Connector No.	M1
Connector Name	WIRE TO WIRE
Connector Color	WHITE

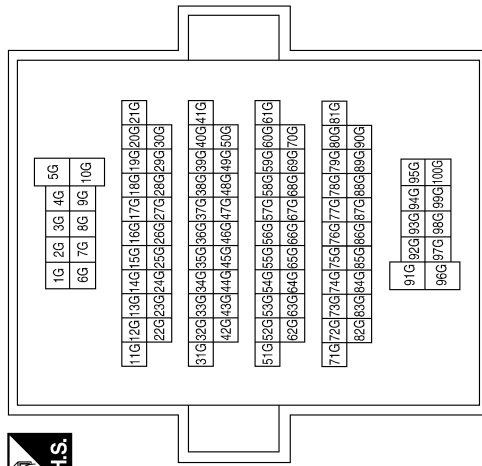

Terminal No.	Color of Wire	Signal Name
2G	BR	-
11G	BR	-
12G	G	-
16G	R	-
22G	L	-
23G	P	-
33G	L	-
34G	W	-

Connector No.	M3
Connector Name	FUSE BLOCK (J/B)
Connector Color	WHITE

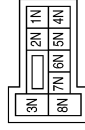

Terminal No.	Color of Wire	Signal Name
2N	LG	-

Connector No.	M5
Connector Name	FUSE BLOCK (J/B)
Connector Color	WHITE



Terminal No.	Color of Wire	Signal Name
8P	BR	-
13P	G	-

ABNIA3639GB

# METER

< WIRING DIAGRAM >

Connector No.	M10
Connector Name	WIRE TO WIRE
Connector Color	BROWN

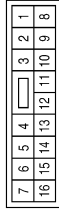

Terminal No.	Color of Wire	Signal Name
13	V	-
14	SB	-

Terminal No.	Color of Wire	Signal Name
76J	SB	-
77J	BR	-
78J	Y	-
79J	W	-
80J	R	-
82J	V	-

Connector No.	M6
Connector Name	WIRE TO WIRE
Connector Color	GRAY

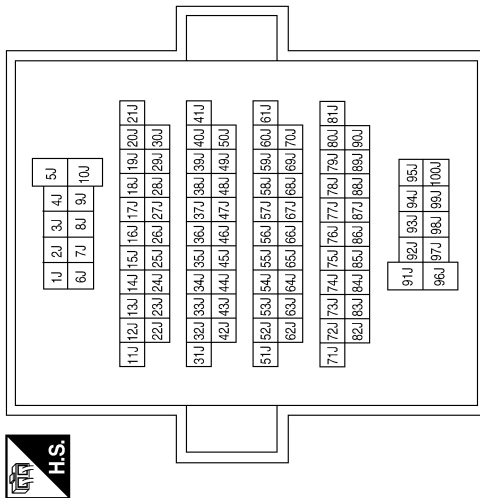

Connector No.	M19
Connector Name	BCM (BODY CONTROL MODULE)
Connector Color	GRAY

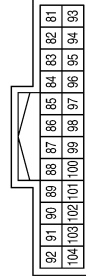

Terminal No.	Color of Wire	Signal Name
82	Y	RL DOOR SW
93	V	RR DOOR SW
94	SB	AS DOOR SW
96	BR	DR DOOR SW
97	SB	TRUNK SW

Connector No.	M18
Connector Name	BCM (BODY CONTROL MODULE)
Connector Color	BLACK

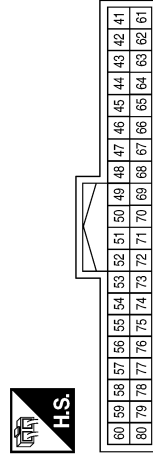

Terminal No.	Color of Wire	Signal Name
59	P	CAN-L
60	L	CAN-H

Connector No.	M17
Connector Name	BCM (BODY CONTROL MODULE)
Connector Color	GREEN

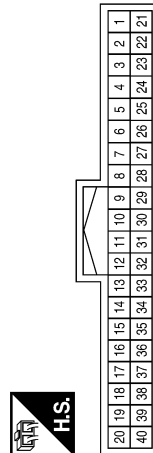

Terminal No.	Color of Wire	Signal Name
18	G	SECURITY INDICATOR

ABNIA3640GB

A  
B  
C  
D  
E  
F  
G  
H  
I  
J  
K  
L  
M  
N  
O  
P



# METER

< WIRING DIAGRAM >

Terminal No.	Color of Wire	Signal Name
16	-	-
17	-	-
18	BR	A/C PD CUT OUT
19	-	-
20	-	-
21	BR	IGN
22	G	BAT
23	GR	ILLUMI CONT OUT (EXCEPT MEXICO)
23	-	- (FOR MEXICO)
24	W	STRG SW GND
25	BR	BRAKE OIL SW
26	R	FUEL SENSOR GND
27	W	FUEL SENSOR
28	-	-
29	-	-
30	L	OAT(VAMB)
31	W	OUT GND
32	-	-
33	R	SPEED 2P/R
34	G	SPEED 8P/R
35	-	-
36	LG	M-CAN L
37	SB	M-CAN H
38	P	CAN-L
39	L	CAN-H
40	-	-

Connector No.	M24
Connector Name	COMBINATION METER
Connector Color	WHITE

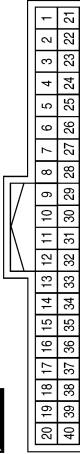

Terminal No.	Color of Wire	Signal Name
1	B	GND1
2	B	GND2
3	P	STRG SW INPUT1
4	R	STRG SW INPUT2
5	P	ACC
6	G	SECURITY
7	R	AIR BAG
8	W	AS BELT
9	V	DR BUCKLE SW
10	-	-
11	R	ALTERNATOR (CHARGE)
12	G	PKB
13	-	-
14	-	-
15	-	-

Connector No.	M23
Connector Name	CVT SHIFT SELECTOR
Connector Color	WHITE

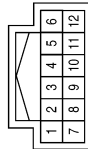

Terminal No.	Color of Wire	Signal Name
1	P	-
2	B	-

Terminal No.	Color of Wire	Signal Name
1	W	-
2	B	-
3	LG	-
5	P	-

Connector No.	M25
Connector Name	ACCESSORY RELAY-2
Connector Color	BLUE



ABNIA3641GB

# METER

< WIRING DIAGRAM >

Connector No.	M30
Connector Name	COMBINATION SWITCH
Connector Color	GRAY

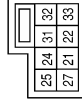

Terminal No.	Color of Wire	Signal Name
24	P	-
31	R	-
33	W	-

Terminal No.	Color of Wire	Signal Name
50	W	AT STRG SHIFT DOWN SW
51	R	AT STRG SHIFT UP SW
52	P	OD OFF/SPORT SW

Connector No.	M26
Connector Name	COMBINATION METER
Connector Color	WHITE

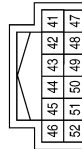

Terminal No.	Color of Wire	Signal Name
41	V	TRIP/RESET
42	SB	ILLUMI DOWN SW
43	-	-
44	-	-
45	-	-
46	-	-
47	Y	ILLUMI UP SW
48	G	SW GND
49	BR	WASHER LEVEL SW

Connector No.	M88
Connector Name	COMBINATION SWITCH
Connector Color	GRAY



Connector No.	M37
Connector Name	FRONT AIR CONTROL (WITHOUT AUTO A/C)
Connector Color	WHITE

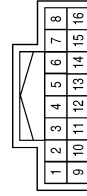

Terminal No.	Color of Wire	Signal Name
14	B	REMOTE A
15	GR	REMOTE B
17	BR	GND

Terminal No.	Color of Wire	Signal Name
16	BR	PD CUT

Connector No.	M35
Connector Name	AIR BAG DIAGNOSIS SENSOR UNIT
Connector Color	YELLOW

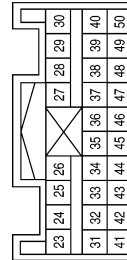

Terminal No.	Color of Wire	Signal Name
35	R	AWL
38	W	SBR
45	P	CAN-L
46	L	CAN-H

ABNIA3642GB

A  
B  
C  
D  
E  
F  
G  
H  
I  
J  
K  
L  
M  
MWI  
O  
P

# METER

< WIRING DIAGRAM >

Connector No.	M95
Connector Name	PADDLE SHIFTER (SHIFT DOWN)
Connector Color	WHITE

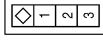

Terminal No.	Color of Wire	Signal Name
1	B	-
3	W	-

Connector No.	M94
Connector Name	PADDLE SHIFTER (SHIFT UP)
Connector Color	WHITE

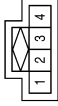

Terminal No.	Color of Wire	Signal Name
1	B	-
3	R	-

Connector No.	M89
Connector Name	JOINT CONNECTOR-M05
Connector Color	WHITE



Terminal No.	Color of Wire	Signal Name
3	L	-
4	L	-

Connector No.	M156
Connector Name	JOINT CONNECTOR-M07
Connector Color	WHITE



Terminal No.	Color of Wire	Signal Name
2	L	-
3	L	-
4	L	-

Connector No.	M155
Connector Name	JOINT CONNECTOR-M06
Connector Color	WHITE



Terminal No.	Color of Wire	Signal Name
3	P	-
4	P	-

Connector No.	M152
Connector Name	A/C AUTO AMP (WITH AUTO A/C)
Connector Color	WHITE

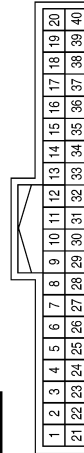

Terminal No.	Color of Wire	Signal Name
1	L	CAN-H
7	L	AMB SENS
21	P	CAN-L
26	W	SENS GND

ABNIA3643GB



# METER

< WIRING DIAGRAM >

Connector No.	E2
Connector Name	WIRE TO WIRE
Connector Color	WHITE

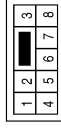

Terminal No.	Color of Wire	Signal Name
8	R	-

Connector No.	M158
Connector Name	METER CONTROL SWITCH
Connector Color	WHITE

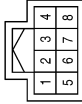

Terminal No.	Color of Wire	Signal Name
1	R	-
2	B	-
4	G	-
5	V	-
6	Y	-
7	SB	-

Connector No.	M157
Connector Name	JOINT CONNECTOR-M08
Connector Color	WHITE



Terminal No.	Color of Wire	Signal Name
2	P	-
3	P	-
4	P	-

Connector No.	E21
Connector Name	JOINT CONNECTOR-E03
Connector Color	GRAY

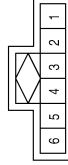

Terminal No.	Color of Wire	Signal Name
1	L	-
2	L	-
3	L	-
4	L	-
5	L	-
6	L	-

Connector No.	E11
Connector Name	WIRE TO WIRE
Connector Color	WHITE

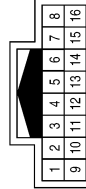

Terminal No.	Color of Wire	Signal Name
1	R	-
2	P	-
9	P	-
10	L	-
16	G	-

Connector No.	E10
Connector Name	ECM (QR25DE EXCEPT FOR CALIFORNIA)
Connector Color	GRAY

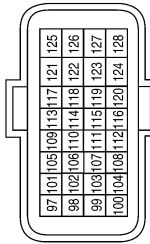

Terminal No.	Color of Wire	Signal Name
99	P	CAN-L
100	L	CAN-H

ABNIA3644GB

A  
B  
C  
D  
E  
F  
G  
H  
I  
J  
K  
L  
M  
MWI  
O  
P

# METER

## < WIRING DIAGRAM >

Connector No.	E22
Connector Name	JOINT CONNECTOR-E04
Connector Color	GRAY

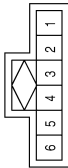

Terminal No.	Color of Wire	Signal Name
1	P	-
2	P	-
3	P	-
4	P	-
5	P	-
6	P	-

Connector No.	E24
Connector Name	BRAKE FLUID LEVEL SWITCH
Connector Color	GRAY



Terminal No.	Color of Wire	Signal Name
1	BG	-
2	GR	-

Connector No.	E30
Connector Name	WIRE TO WIRE
Connector Color	WHITE

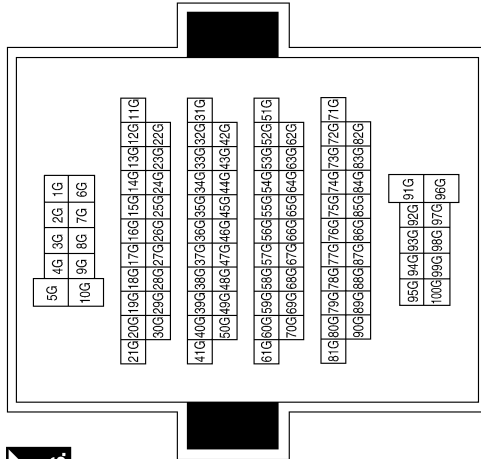

Terminal No.	Color of Wire	Signal Name
2G	R	-
11G	BG	-
12G	LG	-
16G	G	-
22G	L	-
23G	P	-
33G	P	-
34G	BG	-

Connector No.	E31
Connector Name	ECM (OR25DE FOR CALIFORNIA)
Connector Color	GRAY

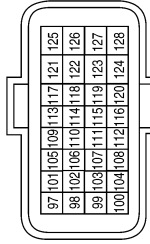

Terminal No.	Color of Wire	Signal Name
99	P	CAN-L
100	L	CAN-H

ABNIA3645GB

# METER

< WIRING DIAGRAM >

Connector No.	E32
Connector Name	ECM (WITH VQ35DE)
Connector Color	GRAY

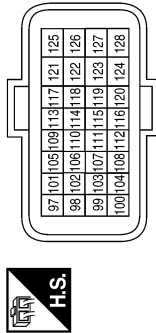

Terminal No.	Color of Wire	Signal Name
107	P	AVCC2-FTPRS/ ELCMPRS/OILPRS
112	R	GNDA-FTPRS/ ELCMPRS/OILPRS
113	P	CAN-L
114	L	CAN-H

Connector No.	E35
Connector Name	PARKING BRAKE SWITCH
Connector Color	BLACK



Terminal No.	Color of Wire	Signal Name
1	LG	-

Connector No.	E54
Connector Name	ABS ACTUATOR AND ELECTRIC UNIT (CONTROL UNIT)
Connector Color	BLACK

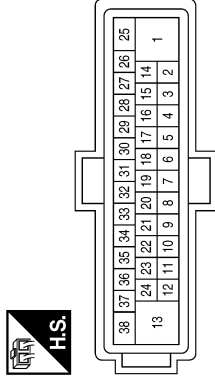

Terminal No.	Color of Wire	Signal Name
14	P	CAN-L
26	L	CAN-H

Connector No.	E56
Connector Name	JOINT CONNECTOR-E08
Connector Color	WHITE

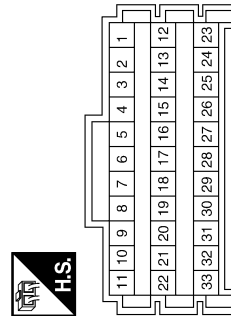

Terminal No.	Color of Wire	Signal Name
4	R	-
5	R	-
12	P	-
14	P	-

Connector No.	E59
Connector Name	POWER STEERING CONTROL MODULE
Connector Color	BLACK

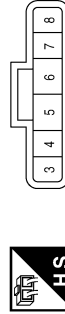

Terminal No.	Color of Wire	Signal Name
7	P	CAN-L
8	L	CAN-H

Connector No.	E63
Connector Name	IPDM E/R (INTELLIGENT POWER DISTRIBUTION MODULE ENGINE ROOM)
Connector Color	WHITE

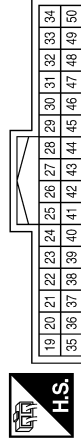

Terminal No.	Color of Wire	Signal Name
28	P	CAN-L
29	L	CAN-H
49	P	AMB SENS SIG-E/R
50	BG	AMB SENS GND-E/R

# METER

## < WIRING DIAGRAM >

Connector No.	E208
Connector Name	WASHER FLUID LEVEL SWITCH
Connector Color	BLACK

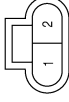

Terminal No.	Color of Wire	Signal Name
1	R	-
2	B	-

Connector No.	E202
Connector Name	WIRE TO WIRE
Connector Color	WHITE

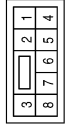

Terminal No.	Color of Wire	Signal Name
8	R	-

Connector No.	E201
Connector Name	IPDM E/R (INTELLIGENT POWER DISTRIBUTION MODULE ENGINE ROOM)
Connector Color	WHITE

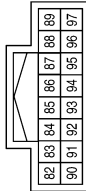

Terminal No.	Color of Wire	Signal Name
87	BG	AMB SENS SIG-FEM
95	R	AMB SENS GND-FEM

Connector No.	F7
Connector Name	GENERATOR
Connector Color	BLACK



Terminal No.	Color of Wire	Signal Name
2	V	L

Connector No.	F2
Connector Name	WIRE TO WIRE
Connector Color	WHITE



Terminal No.	Color of Wire	Signal Name
1	BR	-
2	Y	-
9	P	-
10	L	-
16	V	-

Connector No.	E211
Connector Name	AMBIENT SENSOR
Connector Color	BLACK



Terminal No.	Color of Wire	Signal Name
1	BG	-
2	R	-

ABNIA3647GB

# METER

< WIRING DIAGRAM >

Connector No.	F78
Connector Name	ECM (WITH VQ35DE)
Connector Color	BROWN

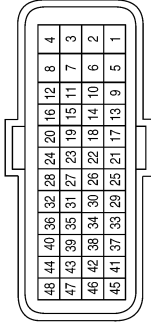

Terminal No.	Color of Wire	Signal Name
4	LG	OIL PRESS SEN

Connector No.	F16
Connector Name	TCM (TRANSMISSION CONTROL MODULE)
Connector Color	BLACK

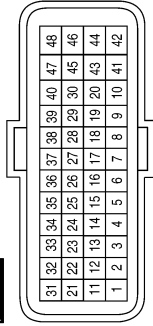

Terminal No.	Color of Wire	Signal Name
23	P	CAN-L
33	L	CAN-H

Connector No.	F14
Connector Name	ECM (QR25DE EXCEPT FOR CALIFORNIA)
Connector Color	BLACK

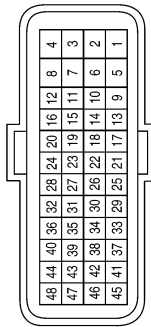

Terminal No.	Color of Wire	Signal Name
38	V	GND-OILPRES
39	L	OILPRES
40	BR	AVCC2-OILPRES

Connector No.	F91
Connector Name	ECM (QR25DE FOR CALIFORNIA)
Connector Color	BLACK

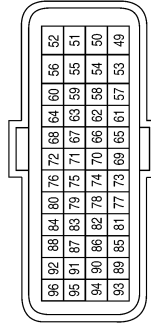

Terminal No.	Color of Wire	Signal Name
38	V	GND-OILPRES
39	L	OILPRES
40	BR	AVCC2-OILPRES

Connector No.	F87
Connector Name	ENGINE OIL PRESSURE SENSOR
Connector Color	BLACK



Terminal No.	Color of Wire	Signal Name
1	V	- (WITH QR25DE)
1	BR	- (WITH VQ35DE)
2	L	- (WITH QR25DE)
2	LG	- (WITH VQ35DE)
3	BR	- (WITH QR25DE)
3	Y	- (WITH VQ35DE)

ABNIA3648GB

A  
B  
C  
D  
E  
F  
G  
H  
I  
J  
K  
L  
M  
N  
O  
P

MWI

# METER

< WIRING DIAGRAM >

Connector No.	B3
Connector Name	JOINT CONNECTOR-B05
Connector Color	WHITE



Terminal No.	Color of Wire	Signal Name
1	LG	-
2	LG	-
3	LG	-

Terminal No.	Color of Wire	Signal Name
76J	W	-
77J	L	-
78J	LG	-
79J	W	-
80J	G	-
82J	LG	-

Connector No.	B1
Connector Name	WIRE TO WIRE
Connector Color	GRAY

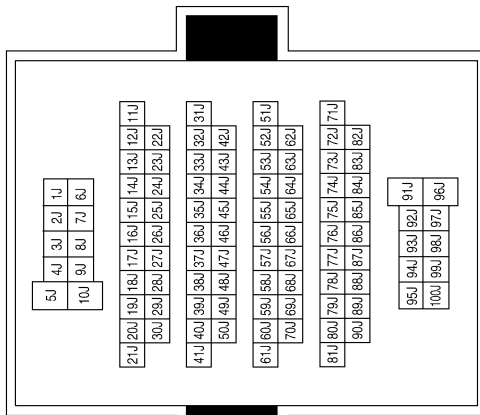

Connector No.	B12
Connector Name	WIRE TO WIRE
Connector Color	WHITE

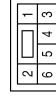

Terminal No.	Color of Wire	Signal Name
3	B	-
6	LG	-

Connector No.	B9
Connector Name	AIR BAG DIAGNOSIS SENSOR UNIT
Connector Color	YELLOW

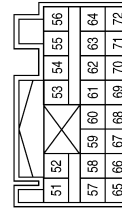

Terminal No.	Color of Wire	Signal Name
67	LG	LH BUCKLE SW (+)

Connector No.	B8
Connector Name	FRONT DOOR SWITCH LH
Connector Color	WHITE



Terminal No.	Color of Wire	Signal Name
3	L	-

ABNIA3649GB

# METER

< WIRING DIAGRAM >

Connector No.	B42
Connector Name	FUEL LEVEL SENSOR UNIT AND FUEL PUMP
Connector Color	GRAY

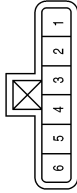

Terminal No.	Color of Wire	Signal Name
2	G	-
5	W	-

Connector No.	B28
Connector Name	TRUNK LAMP SWITCH AND TRUNK RELEASE SOLENOID
Connector Color	WHITE



Terminal No.	Color of Wire	Signal Name
1	W	-
2	GR	-

Connector No.	B18
Connector Name	REAR DOOR SWITCH LH
Connector Color	WHITE

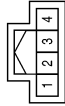

Terminal No.	Color of Wire	Signal Name
3	LG	-

Connector No.	B111
Connector Name	JOINT CONNECTOR-B02
Connector Color	WHITE

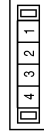

Terminal No.	Color of Wire	Signal Name
3	B	-
4	B	-

Connector No.	B108
Connector Name	FRONT DOOR SWITCH RH
Connector Color	WHITE

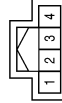

Terminal No.	Color of Wire	Signal Name
3	L	-

Connector No.	B104
Connector Name	WIRE TO WIRE
Connector Color	BROWN



Terminal No.	Color of Wire	Signal Name
13	V	-
14	L	-

ABNIA3650GB

A  
B  
C  
D  
E  
F  
G  
H  
I  
J  
K  
L  
M  
N  
O  
P

MWI

# METER

< WIRING DIAGRAM >

Connector No.	B128
Connector Name	WIRE TO WIRE
Connector Color	WHITE



Terminal No.	Color of Wire	Signal Name
3	B	-
6	L	-

Connector No.	B116
Connector Name	REAR DOOR SWITCH RH
Connector Color	WHITE

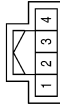

Terminal No.	Color of Wire	Signal Name
3	V	-

Connector No.	B113
Connector Name	AIR BAG DIAGNOSIS SENSOR UNIT
Connector Color	YELLOW

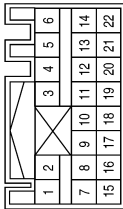

Terminal No.	Color of Wire	Signal Name
20	L	RH BUCKLE SW (+)

Connector No.	B302
Connector Name	SEAT BELT BUCKLE SWITCH RH
Connector Color	WHITE



Terminal No.	Color of Wire	Signal Name
1	L	-
2	B	-

Connector No.	B202
Connector Name	SEAT BELT BUCKLE SWITCH LH
Connector Color	WHITE

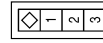

Terminal No.	Color of Wire	Signal Name
1	O	- (EXCEPT MEXICO)
1	LG	- (FOR MEXICO)
2	B	-

Connector No.	B201
Connector Name	WIRE TO WIRE
Connector Color	WHITE

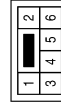

Terminal No.	Color of Wire	Signal Name
3	V	- (EXCEPT MEXICO)
6	B	-
6	LG	- (FOR MEXICO)

ABNIA3652GB



# METER

< WIRING DIAGRAM >

A  
B  
C  
D  
E  
F  
G  
H  
I  
J  
K  
L  
M  
N  
O  
P

Connector No.	B305
Connector Name	WIRE TO WIRE
Connector Color	WHITE

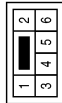

Terminal No.	Color of Wire	Signal Name
3	B	-
6	L	-

MWI

ABNIA3653GB

# DIAGNOSIS AND REPAIR WORKFLOW

< BASIC INSPECTION >

## BASIC INSPECTION

### DIAGNOSIS AND REPAIR WORKFLOW

Work flow

INFOID:000000008693655

#### OVERALL SEQUENCE

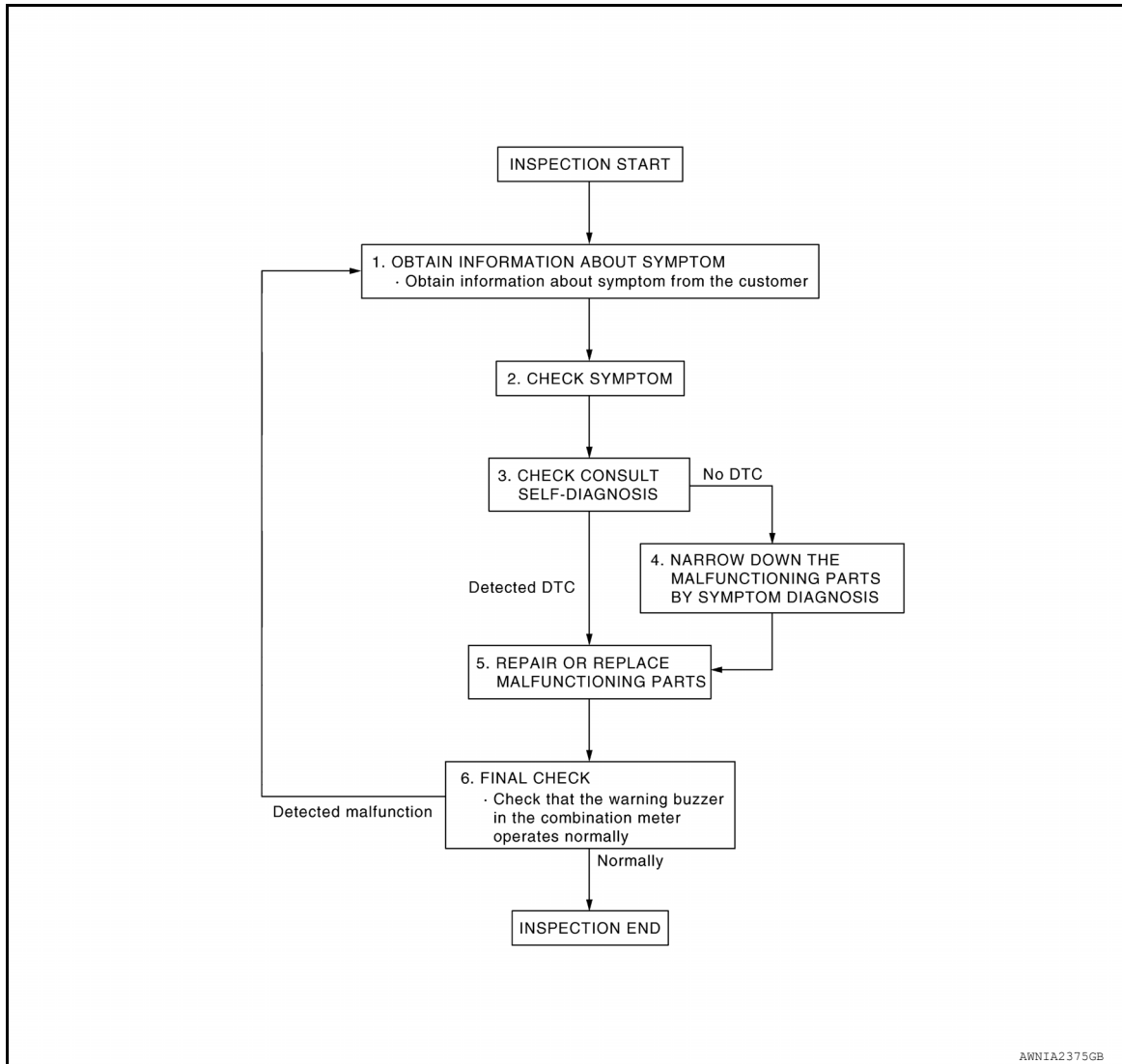

#### DETAILED FLOW

##### 1. OBTAIN INFORMATION ABOUT SYMPTOM

Interview the customer to obtain as much information as possible about the conditions and environment under which the malfunction occurred.

>> GO TO 2.

##### 2. CHECK SYMPTOM

- Check the symptom based on the information obtained from the customer.
- Check if any other malfunctions are present.

>> GO TO 3.

##### 3. CHECK CONSULT SELF-DIAGNOSIS RESULTS

Connect CONSULT and perform self-diagnosis. Refer to [MWI-27. "DTC Index"](#).

# DIAGNOSIS AND REPAIR WORKFLOW

## < BASIC INSPECTION >

---

Are self-diagnosis results normal?

YES >> GO TO 4.

NO >> GO TO 5.

A

## 4.NARROW DOWN MALFUNCTIONING PARTS BY SYMPTOM DIAGNOSIS

---

Perform symptom diagnosis and narrow down the malfunctioning parts.

B

>> GO TO 5.

C

## 5.REPAIR OR REPLACE MALFUNCTIONING PARTS

---

Repair or replace malfunctioning parts.

**NOTE:**

If DTC is displayed, erase DTC after repairing or replacing malfunctioning parts.

D

>> GO TO 6.

E

## 6.FINAL CHECK

---

Check that the warning buzzer in the combination meter operates normally.

Does it operate normally?

F

YES >> Inspection End.

NO >> GO TO 1.

G

H

I

J

K

L

M

MWI

O

P

# U1000 CAN COMM CIRCUIT

< DTC/CIRCUIT DIAGNOSIS >

## DTC/CIRCUIT DIAGNOSIS

### U1000 CAN COMM CIRCUIT

#### DTC Logic

INFOID:000000008693477

#### DTC DETECTION LOGIC

DTC	CONSULT	Detection condition	Possible malfunction location
U1000	CAN COMM CIRC [U1000]	When combination meter is not receiving CAN communication signals for 2 seconds or more.	Combination meter

#### Diagnosis Procedure

INFOID:000000008693478

#### 1. CHECK CAN COMMUNICATION

Select SELF-DIAG RESULTS mode for METER/M&A with CONSULT.

>> GO TO LAN system. Refer to [LAN-18. "Trouble Diagnosis Flow Chart"](#).

# U1010 CONTROL UNIT (CAN)

< DTC/CIRCUIT DIAGNOSIS >

## U1010 CONTROL UNIT (CAN)

### Description

INFOID:000000008693479

Initial diagnosis of combination meter.

### DTC Logic

INFOID:000000008693480

### DTC DETECTION LOGIC

DTC	Display contents of CONSULT	Detection condition	Possible malfunction
U1010	CONTROL UNIT (CAN)	When detecting error during the initial diagnosis of the CAN controller of combination meter.	Combination meter

### Diagnosis Procedure

INFOID:000000008693481

#### 1. REPLACE COMBINATION METER

When DTC U1010 is detected, replace combination meter. Refer to [MWI-81. "Removal and Installation"](#).

>> Inspection End.

A  
B  
C  
D  
E  
F  
G  
H  
I  
J  
K  
L  
M  
O  
P

MWI

## B2205 VEHICLE SPEED

< DTC/CIRCUIT DIAGNOSIS >

### B2205 VEHICLE SPEED

#### Description

INFOID:000000007985706

The ABS actuator and electric unit (control unit) provides a vehicle speed signal to the combination meter via CAN communication lines.

#### DTC Logic

INFOID:000000007985707

DTC	CONSULT	Detection condition	Possible malfunction location
B2205	VEHICLE SPEED CIRC [B2205]	Malfunction is detected when an erroneous speed signal is received for 2 seconds or more.	<ul style="list-style-type: none"><li>• Combination meter</li><li>• ABS actuator and electric unit (control unit)</li></ul>

#### Diagnosis Procedure

INFOID:000000007985708

#### 1. CHECK COMBINATION METER INPUT SIGNAL

1. Start engine and select METER/M&A on CONSULT.
2. Using SPEED METER on DATA MONITOR, compare the value of DATA MONITOR with speedometer pointer of combination meter. Speedometer and DATA MONITOR indications should be close.

#### Is the inspection result normal?

- YES >> Perform ABS actuator and electric unit (control unit) self-diagnosis. Refer to [BRC-33, "CONSULT Function \(ABS\)"](#).
- NO >> Replace combination meter. Refer to [MWI-81, "Removal and Installation"](#).

# B2267 ENGINE SPEED

< DTC/CIRCUIT DIAGNOSIS >

## B2267 ENGINE SPEED

### Description

INFOID:000000008651416

The engine speed signal is transmitted from ECM to the combination meter via CAN communication.

### DTC Logic

INFOID:000000008651365

### DTC DETECTION LOGIC

DTC	CONSULT	Detection condition	Possible malfunction location
B2267	TACHO METER	ECM continuously transmits abnormal engine speed signals for 2 seconds or more	<ul style="list-style-type: none"><li>• Crankshaft position sensor (POS)</li><li>• ECM</li></ul>

### Diagnosis Procedure

INFOID:000000008651366

#### 1. PERFORM SELF-DIAGNOSIS OF ECM

Perform Self Diagnostic Result of ECM, and repair or replace malfunctioning parts.

>> Refer to (QR25DE) [EC-77, "CONSULT Function"](#) or (VQ35DE) [EC-600, "CONSULT Function"](#).

A  
B  
C  
D  
E  
F  
G  
H  
I  
J  
K  
L  
M  
O  
P

MWI

## B2268 WATER TEMP

< DTC/CIRCUIT DIAGNOSIS >

### B2268 WATER TEMP

#### Description

INFOID:000000008651417

The engine coolant temperature signal is transmitted from ECM to the combination meter via CAN communication.

#### DTC Logic

INFOID:000000008651418

#### DTC DETECTION LOGIC

DTC	CONSULT	Detection condition	Probable malfunction location
B2268	WATER TEMP METER	ECM continuously transmits abnormal engine coolant temperature signals for 60 seconds or more	<ul style="list-style-type: none"><li>• Engine coolant temperature sensor</li><li>• ECM</li></ul>

#### Diagnosis Procedure

INFOID:000000008651419

#### 1. PERFORM SELF-DIAGNOSIS OF ECM

Perform Self Diagnostic Result of ECM, and repair or replace malfunctioning parts.

>> Refer to (QR25DE) [EC-77. "CONSULT Function"](#) or (VQ35DE) [EC-600. "CONSULT Function"](#).



# POWER SUPPLY AND GROUND CIRCUIT

< DTC/CIRCUIT DIAGNOSIS >

## POWER SUPPLY AND GROUND CIRCUIT COMBINATION METER

### COMBINATION METER : Diagnosis Procedure

INFOID:000000007985709

Regarding Wiring Diagram information, refer to [MWI-31. "Wiring Diagram"](#).

#### 1. CHECK FUSES

Check that the following fuses are not blown.

Unit	Power source	Fuse No.
Combination meter	Battery	13
		25
	Ignition switch ON or START	31

Is the fuse blown?

YES >> Replace the blown fuse after repairing the affected circuit.

NO >> GO TO 2.

#### 2. POWER SUPPLY CIRCUIT CHECK

1. Disconnect combination meter connector.
2. Check voltage between combination meter harness connector M24 terminals 5, 21, 22 and ground.

Terminals		Ignition switch position				
(+) Terminal		(-)	OFF	ACC	ON	START
Connector M24	22	Ground	Battery voltage	Battery voltage	Battery voltage	Battery voltage
	21		0V	0V	Battery voltage	Battery voltage
	5		0V	Battery voltage	Battery voltage	0V

Is the inspection result normal?

YES >> GO TO 3.

NO >> Repair or replace harness or connectors.

#### 3. GROUND CIRCUIT CHECK

1. Turn ignition switch OFF.
2. Check continuity between combination meter harness connector M24 terminals 1, 2 and ground.

Terminals		Continuity
(+) Connector	(-) Terminal	
M24	1	Ground Yes
	2	

Is the inspection result normal?

YES >> Inspection End.

NO >> Repair or replace harness or connectors.

## BCM (BODY CONTROL MODULE)

### BCM (BODY CONTROL MODULE) : Diagnosis Procedure

INFOID:000000008689549

Regarding Wiring Diagram information, refer to [BCS-52. "Wiring Diagram"](#).

# POWER SUPPLY AND GROUND CIRCUIT

< DTC/CIRCUIT DIAGNOSIS >

## 1. CHECK FUSE AND FUSIBLE LINK

Check that the following fuse and fusible link are not blown.

Terminal No.	Signal name	Fuse and fusible link No.
139	Fusible link battery power	I (40A)
131	BCM battery fuse	1 (10A)

Is the fuse or fusible link blown?

YES >> Replace the blown fuse or fusible link after repairing the affected circuit.

NO >> GO TO 2

## 2. CHECK POWER SUPPLY CIRCUIT

1. Disconnect BCM connector M21.
2. Check voltage between BCM connector M21 terminals 131, 139 and ground.

BCM		Ground	Voltage (Approx.)
Connector	Terminal		
M21	131	—	Battery voltage
	139		

Is the inspection result normal?

YES >> GO TO 3

NO >> Repair or replace harness or connectors.

## 3. CHECK GROUND CIRCUIT

Check continuity between BCM connector M21 terminals 134, 143 and ground.

BCM		Ground	Continuity
Connector	Terminal		
M21	134	—	Yes
	143		

Is the inspection result normal?

YES >> Inspection End.

NO >> Repair or replace harness or connectors.

IPDM E/R (INTELLIGENT POWER DISTRIBUTION MODULE ENGINE ROOM)

IPDM E/R (INTELLIGENT POWER DISTRIBUTION MODULE ENGINE ROOM) : Diagnosis Procedure

INFOID:000000008689551

Regarding Wiring Diagram information, refer to [PCS-21, "Wiring Diagram"](#).

## 1. CHECK FUSIBLE LINKS

Check that the following fusible links are not blown.

Terminal No.	Signal name	Fusible link No.
1	Fusible link main	E (80A)
2	Fusible link IPDM E/R	A (250A), C (80A)
3	Fusible link ignition switch	A (250A), B (100A), M (40A)

Is the fusible link blown?

# POWER SUPPLY AND GROUND CIRCUIT

## < DTC/CIRCUIT DIAGNOSIS >

- YES >> Replace the blown fusible link after repairing the affected circuit.  
NO >> GO TO 2

### 2. CHECK POWER SUPPLY CIRCUIT

1. Disconnect IPDM E/R connectors E16 and E17.
2. Check voltage between IPDM E/R connectors and ground.

IPDM E/R		Ground	Voltage (Approx.)
Connector	Terminal		
E16	1	—	Battery voltage
	2		
E17	3		

#### Is the inspection result normal?

- YES >> GO TO 3  
NO >> Repair or replace harness or connectors.

### 3. CHECK GROUND CIRCUIT

1. Disconnect IPDM E/R connectors E18 and E63.
2. Check continuity between IPDM E/R connectors and ground.

IPDM E/R		Ground	Continuity
Connector	Terminal		
E18	7	—	Yes
E63	41		

#### Is the inspection result normal?

- YES >> Inspection End.  
NO >> Repair or replace harness or connectors.

A  
B  
C  
D  
E  
F  
G  
H  
I  
J  
K  
L  
M  
O  
P



# FUEL LEVEL SENSOR SIGNAL CIRCUIT

< DTC/CIRCUIT DIAGNOSIS >

## FUEL LEVEL SENSOR SIGNAL CIRCUIT

### Description

INFOID:000000007985713

The fuel level sensor unit and fuel pump detects the approximate fuel level in the fuel tank and transmits the fuel level signal to the combination meter.

### Component Function Check

INFOID:000000007985714

#### 1.COMBINATION METER INPUT SIGNAL

1. Select METER/M&A on CONSULT.
2. Using FUEL METER of DATA MONITOR, compare the value of DATA MONITOR with fuel gauge pointer of combination meter.

Fuel gauge pointer	Fuel tank volume [L] (Approx.)
Full	67.6
3/4	52.6
1/2	37.6
1/4	22.5
Empty	0.0

Does the data monitor value approximately match the fuel gauge indication?

YES >> Inspection End.

NO >> Replace combination meter. Refer to [MWI-81, "Removal and Installation"](#).

### Diagnosis Procedure

INFOID:000000007985715

Regarding Wiring Diagram information, refer to [MWI-31, "Wiring Diagram"](#).

#### 1.CHECK HARNESS CONNECTOR

1. Turn ignition switch OFF.
2. Check combination meter and fuel level sensor unit terminals (meter-side and harness-side) for poor connection.

Is the inspection result normal?

YES >> GO TO 2.

NO >> Repair or replace terminals or connectors.

#### 2.CHECK FUEL LEVEL SENSOR UNIT CIRCUIT

1. Disconnect combination meter harness connector M24 and fuel level sensor unit harness connector B42.
2. Check continuity between combination meter harness connector M24 and fuel level sensor unit and fuel pump harness connector B42.

Fuel level sensor unit and fuel pump		Combination meter		Continuity
Connector	Terminal	Connector	Terminal	
B42	5	M24	27	Yes

3. Check continuity between fuel level sensor unit and fuel pump harness connector and ground.

Connector	Terminal	Ground	Continuity
B42	5		No

Is the inspection result normal?

YES >> GO TO 3.

# FUEL LEVEL SENSOR SIGNAL CIRCUIT

## < DTC/CIRCUIT DIAGNOSIS >

NO >> Repair or replace harness or connectors.

### 3. CHECK FUEL LEVEL SENSOR UNIT GROUND CIRCUIT

1. Check continuity between combination meter harness connector M24 and fuel level sensor unit and fuel pump harness connector B42.

Connector	Terminal	Connector	Terminal	Continuity
B42	2	M24	26	Yes

2. Check continuity between fuel level sensor unit and fuel pump harness connector and ground.

Connector	Terminal	Ground	Continuity
B42	2		No

Is the inspection result normal?

YES >> GO TO 4.

NO >> Repair or replace harness or connectors.

### 4. CHECK INSTALLATION CONDITION

Check fuel level sensor unit installation, and check whether the float arm interferes or binds with any of the internal components in the fuel tank.

Is the inspection result normal?

YES >> Inspection End.

NO >> Install the fuel level sensor unit properly. Refer to [FL-6. "Removal and Installation"](#).

## Component Inspection

INFOID:000000007985716

### 1. REMOVE FUEL LEVEL SENSOR UNIT

Remove the fuel level sensor unit. Refer to [FL-6. "Removal and Installation"](#).

>> GO TO 2

### 2. CHECK FUEL LEVEL SENSOR UNIT AND FUEL PUMP

Check the resistance between terminals 2 and 5.

Terminal		Float position mm (in)		Resistance value (Approx.)
2	5	1*	Empty	32.2 (1.3)
		2*	Full	148.8 (5.9)

1\* and 2\*: When float arm is in contact with stopper.

Is inspection result normal?

YES >> Inspection End.

NO >> Replace fuel level sensor unit and fuel pump. Refer to [FL-6. "Removal and Installation"](#).

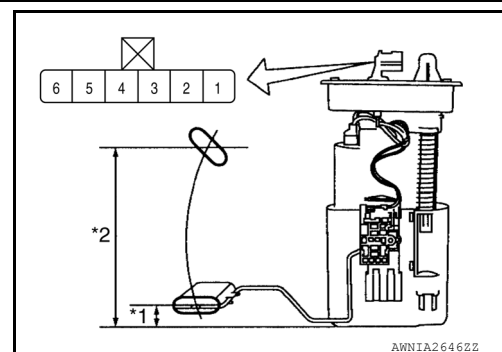

A  
B  
C  
D  
E  
F  
G  
H  
I  
J  
K  
L  
M  
N  
O  
P

MWI

# PARKING BRAKE SWITCH SIGNAL CIRCUIT

< DTC/CIRCUIT DIAGNOSIS >

## PARKING BRAKE SWITCH SIGNAL CIRCUIT

### Description

INFOID:000000007985721

Transmits the parking brake switch signal to the combination meter.

### Component Function Check

INFOID:000000007985722

#### 1.COMBINATION METER INPUT SIGNAL

1. Start engine.
2. Monitor BRAKE W/L in DATA MONITOR while applying and releasing the parking brake.

**Condition**                      **CONSULT**  
**Parking brake applied**        : **ON**  
**Parking brake released**       : **OFF**

>> Inspection End.

### Diagnosis Procedure

INFOID:000000007985723

Regarding Wiring Diagram information, refer to [MWI-31, "Wiring Diagram"](#).

#### 1.CHECK PARKING BRAKE SWITCH CIRCUIT

1. Disconnect combination meter harness connector M24 and parking brake switch harness connector E35.
2. Check continuity between combination meter harness connector M24 terminal 12 and parking brake switch harness connector E35 terminal 1.

Combination meter		Parking brake switch		Continuity
Connector	Terminal	Connector	Terminal	
M24	12	E35	1	Yes

3. Check continuity between combination meter harness connector M24 terminal 12 and ground.

Combination meter		Ground	Continuity
Connector	Terminal		
M24	12		No

Is the inspection result normal?

- YES    >> Inspection End.  
NO     >> Repair or replace harness or connector.

### Component Inspection

INFOID:000000007985724

#### 1.CHECK PARKING BRAKE SWITCH

Check continuity between parking brake switch terminal 1 and switch case ground.

Component	Terminal	Condition	Continuity
Parking brake switch	1	Parking brake applied	Yes
		Parking brake released	No

Is the inspection result normal?

- YES    >> Inspection End.  
NO     >> Replace parking brake switch. Refer to [PB-7, "Exploded View"](#).

# WASHER FLUID LEVEL SWITCH CIRCUIT

< DTC/CIRCUIT DIAGNOSIS >

## WASHER FLUID LEVEL SWITCH CIRCUIT

### Description

INFOID:000000007985725

Transmits the washer fluid level switch signal to the combination meter.

### Diagnosis Procedure

INFOID:000000007985727

Regarding Wiring Diagram information, refer to [MWI-31, "Wiring Diagram"](#).

### 1. CHECK WASHER FLUID LEVEL SWITCH SIGNAL CIRCUIT

1. Turn ignition switch OFF.
2. Disconnect combination meter harness connector M26 and washer fluid level switch harness connector E208.
3. Check continuity between combination meter harness connector M26 and washer fluid level switch harness connector E208.

Combination meter		Washer fluid level switch		Continuity
Connector	Terminal	Connector	Terminal	
M26	49	E208	1	Yes

4. Check continuity between combination meter harness connector and ground.

Combination meter		Ground	Continuity
Connector	Terminal		
M26	49		No

Is the inspection result normal?

YES >> GO TO 2.

NO >> Repair or replace harness or connectors.

### 2. CHECK WASHER FLUID LEVEL SWITCH GROUND CIRCUIT

Check continuity between washer fluid level switch connector and ground.

Washer fluid level switch		Ground	Continuity
Connector	Terminal		
E208	2		Yes

Is the inspection result normal?

YES >> Inspection End.

NO >> Repair or replace harness or connectors.

### Component Inspection

INFOID:000000007985728

### 1. CHECK WASHER FLUID LEVEL SWITCH

1. Turn ignition switch OFF.
2. Disconnect washer fluid level switch connector.
3. Check washer fluid level switch.

Washer fluid level switch		Condition	Continuity
Terminals			
1	2	Washer fluid level switch ON	Yes
		Washer fluid level switch OFF	No

Is the inspection result normal?

A  
B  
C  
D  
E  
F  
G  
H  
I  
J  
K  
L  
M  
O  
P

MWI

## WASHER FLUID LEVEL SWITCH CIRCUIT

### < DTC/CIRCUIT DIAGNOSIS >

---

YES >> Inspection End.

NO >> Replace washer fluid level switch. Refer to [WW-53, "Removal and Installation"](#).



# AMBIENT SENSOR SIGNAL CIRCUIT

< DTC/CIRCUIT DIAGNOSIS >

## AMBIENT SENSOR SIGNAL CIRCUIT

### Description

INFOID:000000007985729

Transmits the ambient sensor signal to the IPDM E/R.

### Component Function Check

INFOID:000000007985730

#### 1.COMBINATION METER INPUT SIGNAL

1. Select METER/M&A on CONSULT.
2. Check OUTSIDE TEMP on DATA MONITOR.

Does the ambient temperature approximately match the CONSULT display?

- YES >> Replace combination meter. Refer to [MWI-81, "Removal and Installation"](#).  
NO >> Refer to [MWI-65, "Diagnosis Procedure"](#).

### Diagnosis Procedure

INFOID:000000007985731

Regarding Wiring Diagram information, refer to [MWI-31, "Wiring Diagram"](#).

#### 1.CHECK AMBIENT SENSOR CIRCUITS BETWEEN COMBINATION METER AND IPDM E/R

1. Disconnect combination meter connector M24 and IPDM E/R connector E63.
2. Check continuity between combination meter harness connector M24 terminals 30, 31 and IPDM E/R harness connector E63 terminals 49 and 50.

Connector	Terminal	Connector	Terminal	Continuity
M24	30	E63	49	Yes
	31		50	

3. Check continuity between combination meter harness connector M24 terminals 30, 31 and ground.

Connector	Terminal	Continuity
M24	30	No
	31	

Is the inspection result normal?

- YES >> GO TO 2.  
NO >> Repair or replace harness or connector.

#### 2.CHECK AMBIENT SENSOR CIRCUITS BETWEEN IPDM E/R AND AMBIENT SENSOR

1. Disconnect IPDM E/R connector E201 and ambient sensor connector E211.
2. Check continuity between IPDM E/R harness connector E201 terminals 87, 95 and ambient sensor harness connector E211 terminals 1 and 2.

Connector	Terminal	Connector	Terminal	Continuity
E201	87	E211	1	Yes
	95		2	

3. Check continuity between IPDM E/R harness connector E201 terminals 87, 95 and ground.

Connector	Terminal	Continuity
E201	87	No
	95	

Is the inspection result normal?

A  
B  
C  
D  
E  
F  
G  
H  
I  
J  
K  
L  
M  
O  
P

MWI

# AMBIENT SENSOR SIGNAL CIRCUIT

## < DTC/CIRCUIT DIAGNOSIS >

- YES >> Replace IPDM E/R. Refer to [PCS-32, "Removal and Installation"](#).  
NO >> Repair or replace harness or connector.

## Component Inspection

INFOID:000000007985732

### 1. CHECK AMBIENT SENSOR

1. Turn ignition switch OFF.
2. Disconnect ambient sensor connector.
3. Check resistance between ambient sensor terminals.

Terminal		Condition	Resistance: kΩ
		Temperature: °C (°F)	
1	2	-15 (5)	12.73
		-10 (14)	9.92
		-5 (23)	7.80
		0 (32)	6.19
		5 (41)	4.95
		10 (50)	3.99
		15 (59)	3.24
		20 (68)	2.65
		25 (77)	2.19
		30 (86)	1.81
		35 (95)	1.51
		40 (104)	1.27
		45 (113)	1.07

### Is the inspection result normal?

- YES >> Inspection End.  
NO >> Replace ambient sensor. Refer to [MWI-82, "Removal and Installation"](#).

# METER CONTROL SWITCH SIGNAL CIRCUIT

< DTC/CIRCUIT DIAGNOSIS >

## METER CONTROL SWITCH SIGNAL CIRCUIT

### Diagnosis Procedure

INFOID:000000008693507

Regarding Wiring Diagram information, refer to [MWI-31, "Wiring Diagram"](#).

### 1. CHECK METER CONTROL SWITCH SIGNAL

- Turn ignition switch ON.
- Check voltage between the following terminals of the meter control switch harness connector M158.

Meter control switch		Condition	Voltage (Approx.)
Connector	Terminals		
		(+)      (-)	
M158	7	When illumination control switch (-) is pressed	0 V
		Other than the above	5 V
	5	When trip reset switch is pressed	0 V
		Other than the above	5 V
	6	When illumination control switch (+) is pressed	0 V
		Other than the above	5 V

Is the inspection result normal?

YES >> Inspection End.

NO >> GO TO 2.

### 2. CHECK METER CONTROL SWITCH HARNESS

- Turn ignition switch OFF.
- Disconnect combination meter harness connector M26 and meter control switch harness connector M158.
- Check continuity between combination meter harness connector M26 and meter control switch harness connector M158.

Combination meter		Meter control switch		Continuity
Connector	Terminal	Connector	Terminal	
M26	41	M158	5	Yes
	42		7	
	47		6	
	48		4	

- Check continuity between combination meter harness connector and ground.

Combination meter		Ground	Continuity
Connector	Terminal		
M26	41		No
	42		
	47		
	48		

Is the inspection result normal?

YES >> Inspection End.

NO >> Repair or replace harness or connectors.

# METER CONTROL SWITCH SIGNAL CIRCUIT

< DTC/CIRCUIT DIAGNOSIS >

## Component Inspection

INFOID:000000008693508

### 1. CHECK METER CONTROL SWITCH

1. Turn ignition switch OFF.
2. Disconnect meter control switch connector.
3. Check meter control switch.

Meter control switch		Condition	Continuity
Terminals			
7	4	When illumination control switch (-) is pressed	Yes
		Other than the above	No
5		When trip reset switch is pressed	Yes
		Other than the above	No
6		When illumination control switch (+) is pressed	Yes
		Other than the above	No

Is the inspection result normal?

YES >> Inspection End.

NO >> Replace meter control switch. Refer to [IP-14. "Exploded View"](#).

# STEERING SWITCH

< DTC/CIRCUIT DIAGNOSIS >

## STEERING SWITCH

### Description

INFOID:000000008651501

When one of the steering switches is pushed, the resistance in the steering switch changes the signal to identify which button is controlling the information display.

### Diagnosis Procedure

INFOID:000000008651500

Regarding Wiring Diagram information, refer to [MWI-31, "Wiring Diagram"](#).

### 1.CHECK STEERING SWITCH CIRCUIT

1. Turn ignition switch OFF.
2. Disconnect combination meter harness connector M24 and spiral cable harness connector M30.
3. Check continuity between combination meter harness connector M24 and spiral cable harness connector M30.

Combination meter		Spiral cable		Continuity
Connector	Terminal	Connector	Terminal	
M24	3	M30	24	Yes
	4		31	
	24		33	

4. Check continuity between combination meter harness connector M24 and ground.

Combination meter		Ground	Continuity
Connector	Terminal		
M24	3	Ground	No
	4		
	24		

Is the inspection results normal?

- YES >> Inspection End.  
 NO >> Repair or replace harness or connectors.

### Component Inspection

INFOID:000000008693496

### 1.CHECK STEERING SWITCH RESISTANCE

Check resistance between the following steering switch terminals.

Terminal	Signal name	Condition	Resistance (Ω) (Approx.)
14	Display	Depress DISPLAY switch. □	2023
	Back	Depress BACK switch. ↶	723
15	Enter	Depress ENTER switch.	2023
	Menu Up	Depress ENTER switch up. △	121
	Menu Down	Depress ENTER switch down. ▽	321

Is the inspection results normal?

- YES >> GO TO 2.  
 NO >> Replace steering wheel switch. Refer to [AV-49, "Removal and Installation"](#).

A  
B  
C  
D  
E  
F  
G  
H  
I  
J  
K  
L  
M  
O  
P

MWI

## STEERING SWITCH

< DTC/CIRCUIT DIAGNOSIS >

### 2.CHECK SPIRAL CABLE

Check continuity between the following spiral cable terminals.

Terminals		Continuity
14	24	Yes
15	31	
17	33	

Is the inspection results normal?

YES >> Inspection End.

NO >> Replace spiral cable. Refer to [SR-15, "Removal and Installation"](#).

# THE FUEL GAUGE INDICATOR DOES NOT OPERATE

< SYMPTOM DIAGNOSIS >

## SYMPTOM DIAGNOSIS

### THE FUEL GAUGE INDICATOR DOES NOT OPERATE

#### Description

INFOID:000000008693459

Fuel gauge will not indicate from a certain position.

#### Diagnosis Procedure

INFOID:000000008693460

#### 1. CHECK COMBINATION METER INPUT SIGNAL

Perform component function check. Refer to [MWI-60, "Component Function Check"](#).

Does monitor value match fuel gauge reading?

YES >> GO TO 2.

NO >> Replace combination meter. Refer to [MWI-81, "Removal and Installation"](#).

#### 2. CHECK FUEL LEVEL SENSOR UNIT CIRCUITS

Check the fuel level sensor circuits. Refer to [MWI-60, "Diagnosis Procedure"](#).

Is the inspection result normal?

YES >> GO TO 3.

NO >> Repair or replace harness or connectors.

#### 3. CHECK FUEL LEVEL SENSOR UNIT

Perform a unit check for the fuel level sensor unit. Refer to [MWI-61, "Component Inspection"](#).

Is the inspection result normal?

YES >> GO TO 4.

NO >> Replace fuel level sensor unit. Refer to [FL-6, "Removal and Installation"](#).

#### 4. CHECK FLOAT INTERFERENCE

Check that the float arm does not interfere with or binds to other components in the fuel tank.

Is the inspection result normal?

YES >> Replace combination meter. Refer to [MWI-81, "Removal and Installation"](#).

NO >> Repair or replace malfunctioning parts.

A  
B  
C  
D  
E  
F  
G  
H  
I  
J  
K  
L  
M  
O  
P

MWI

# THE METER CONTROL SWITCH IS INOPERATIVE

< SYMPTOM DIAGNOSIS >

---

## THE METER CONTROL SWITCH IS INOPERATIVE

### Description

INFOID:000000008693653

The meter control switches are inoperative when pressed.

### Diagnosis Procedure

INFOID:000000008693654

#### 1. CHECK METER CONTROL SWITCH SIGNAL

---

Check the meter control switch signal. Refer to [MWI-67, "Diagnosis Procedure"](#).

Is the inspection results normal?

YES >> GO TO 2.

NO >> Repair or replace harness or connectors.

#### 2. CHECK METER CONTROL SWITCH

---

Perform a unit check for the meter control switch. Refer to [MWI-68, "Component Inspection"](#).

Is the inspection results normal?

YES >> Replace combination meter. Refer to [MWI-81, "Removal and Installation"](#).

NO >> Replace meter control switch. Refer to [IP-14, "Exploded View"](#).



# THE OIL PRESSURE WARNING CONTINUES DISPLAYING, OR DOES NOT DISPLAY

< SYMPTOM DIAGNOSIS >

## THE OIL PRESSURE WARNING CONTINUES DISPLAYING, OR DOES NOT DISPLAY

### Description

INFOID:000000008651307

- The low oil pressure warning message stays on when oil pressure is normal.
- The low oil pressure warning message stays off when oil pressure is low.

### Diagnosis Procedure

INFOID:000000008651308

#### 1. CHECK COMBINATION METER INPUT

1. Start the engine and select METER/M&A on CONSULT.
2. Observe OIL W/L DATA MONITOR and the operation of the low oil pressure warning message in the information display.

Component	Condition	CONSULT
Low oil pressure warning message	Engine running	OFF

#### Is the inspection result normal?

- YES >> Perform ECM self-diagnosis. Refer to (QR25DE) [EC-77, "CONSULT Function"](#) or (VQ35DE) [EC-600, "CONSULT Function"](#).
- NO >> Replace combination meter. Refer to [MWI-81, "Removal and Installation"](#).

MWI

# THE PARKING BRAKE RELEASE WARNING CONTINUES DISPLAYING, OR DOES NOT DISPLAY

< SYMPTOM DIAGNOSIS >

## THE PARKING BRAKE RELEASE WARNING CONTINUES DISPLAYING, OR DOES NOT DISPLAY

### Description

INFOID:000000007985757

- The parking brake warning is displayed while driving the vehicle even though the parking brake is released.
- The parking brake warning is not displayed even though driving the vehicle with the parking brake depressed.

### Diagnosis Procedure

INFOID:000000007985758

#### 1. CHECK PARKING BRAKE WARNING LAMP OPERATION

1. Start engine.
2. Check the operation of the brake warning lamp while operating the parking brake.

Condition	Warning lamp status
Parking brake applied	ON
Parking brake released	OFF

#### Is the inspection result normal?

- YES >> Replace combination meter. Refer to [MWI-81, "Removal and Installation"](#).  
NO >> GO TO 2.

#### 2. CHECK PARKING BRAKE SWITCH SIGNAL CIRCUIT

1. Turn ignition switch OFF.
2. Check the parking brake switch signal circuit. Refer to [MWI-62, "Diagnosis Procedure"](#).

#### Is the inspection result normal?

- YES >> GO TO 3.  
NO >> Repair or replace harness or connectors.

#### 3. CHECK PARKING BRAKE SWITCH UNIT

Perform a unit check for the parking brake switch. Refer to [MWI-62, "Component Inspection"](#).

#### Is the inspection result normal?

- YES >> Replace combination meter. Refer to [MWI-81, "Removal and Installation"](#).  
NO >> Replace parking brake switch. Refer to [PB-7, "Exploded View"](#).

# THE LOW WASHER FLUID WARNING CONTINUES DISPLAYING, OR DOES NOT DISPLAY

< SYMPTOM DIAGNOSIS >

## THE LOW WASHER FLUID WARNING CONTINUES DISPLAYING, OR DOES NOT DISPLAY

### Description

INFOID:000000007985759

- The warning is still displayed even after washer fluid is added.
- The warning is not displayed even though the washer tank is empty.

### Diagnosis Procedure

INFOID:000000007985760

#### 1. CHECK WASHER FLUID LEVEL SWITCH SIGNAL CIRCUIT

Check the washer fluid level switch signal circuit. Refer to [MWI-63. "Diagnosis Procedure"](#).

Is the inspection result normal?

YES >> GO TO 2.

NO >> Repair or replace harness or connector.

#### 2. CHECK WASHER FLUID LEVEL SWITCH UNIT

Perform a unit check for the washer fluid level switch. Refer to [MWI-63. "Component Inspection"](#).

Is the inspection result normal?

YES >> Replace combination meter. Refer to [MWI-81. "Removal and Installation"](#).

NO >> Replace washer fluid level switch. Refer to [WW-53. "Removal and Installation"](#).

A  
B  
C  
D  
E  
F  
G  
H  
I  
J  
K  
L  
M  
O  
P

MWI

# THE DOOR OPEN WARNING CONTINUES DISPLAYING, OR DOES NOT DISPLAY

< SYMPTOM DIAGNOSIS >

## THE DOOR OPEN WARNING CONTINUES DISPLAYING, OR DOES NOT DISPLAY

### Description

INFOID:000000007985761

- The door ajar warning is displayed even though all of the doors and the trunk are closed.
- The door ajar warning is not displayed even though a door or the trunk is ajar.

### Diagnosis Procedure

INFOID:000000007985762

#### 1. CHECK BCM INPUT SIGNAL

Check the BCM input signal. Refer to [DLK-99, "Component Function Check"](#).

Is the inspection result normal?

- YES >> GO TO 2.
- NO >> GO TO 3.

#### 2. CHECK COMBINATION METER INPUT SIGNAL

Select the METER/M&A Data Monitor and check the DOOR W/L monitor value while opening and closing doors.

DOOR W/L	
Door open	: On
Door closed	: Off

Is the inspection result normal?

- YES >> Replace combination meter. Refer to [MWI-81, "Removal and Installation"](#).
- NO >> Replace BCM. Refer to [BCS-77, "Removal and Installation"](#).

#### 3. CHECK DOOR SWITCH SIGNAL CIRCUIT

Check the door switch signal circuit. Refer to [DLK-99, "Diagnosis Procedure"](#).

Is the inspection result normal?

- YES >> GO TO 4.
- NO >> Repair or replace harness or connectors.

#### 4. CHECK DOOR SWITCH

Perform a unit check for the door switch. Refer to [DLK-101, "Component Inspection"](#).

Is the inspection result normal?

- YES >> Replace combination meter. Refer to [MWI-81, "Removal and Installation"](#).
- NO >> Replace applicable door switch. Refer to [DLK-218, "Removal and Installation"](#).

# THE TRUNK OPEN WARNING CONTINUES DISPLAYING, OR DOES NOT DISPLAY

< SYMPTOM DIAGNOSIS >

## THE TRUNK OPEN WARNING CONTINUES DISPLAYING, OR DOES NOT DISPLAY

### Description

INFOID:000000008702711

- The trunk ajar warning is displayed continuously even though the trunk lid is closed.
- The trunk ajar warning is not displayed even though the trunk lid is open.

### Diagnosis Procedure

INFOID:000000008702712

#### 1. CHECK BCM INPUT SIGNAL

1. Connect the CONSULT.
2. Check the BCM input signals. Refer to [DLK-125, "Component Function Check"](#).

Is the inspection result normal?

- YES >> GO TO 2.
- NO >> GO TO 3.

#### 2. CHECK COMBINATION METER INPUT SIGNAL

Select the Data Monitor for the METER/M&A and check the TRUNK/GLAS-H monitor value.

TRUNK/GLAS-H

Trunk lid open : On

Trunk lid closed : Off

Is the inspection result normal?

- YES >> Replace combination meter. Refer to [MWI-81, "Removal and Installation"](#).
- NO >> Replace BCM. Refer to [BCS-77, "Removal and Installation"](#).

#### 3. CHECK TRUNK ROOM LAMP SWITCH SIGNAL CIRCUIT

Check the trunk room lamp switch signal circuit. Refer to [DLK-125, "Diagnosis Procedure"](#).

Is the inspection result normal?

- YES >> GO TO 4.
- NO >> Repair harness or connector.

#### 4. CHECK TRUNK ROOM LAMP SWITCH

Check the room lamp switch. Refer to [DLK-126, "Component Inspection"](#).

Is the inspection result normal?

- YES >> Replace combination meter. Refer to [MWI-81, "Removal and Installation"](#).
- NO >> Replace trunk lid lock assembly. Refer to [DLK-209, "TRUNK LID LOCK : Removal and Installation"](#).

A  
B  
C  
D  
E  
F  
G  
H  
I  
J  
K  
L  
M  
O  
P

MWI

# THE STEERING SWITCHES ARE INOPERATIVE

< SYMPTOM DIAGNOSIS >

---

## THE STEERING SWITCHES ARE INOPERATIVE

### Description

INFOID:000000008693656

One or more of the steering switches to control the information display are inoperative.

### Diagnosis Procedure

INFOID:000000008693657

#### 1. CHECK STEERING SWITCH CIRCUIT

---

Check steering switch circuit. Refer to [MWI-69, "Diagnosis Procedure"](#).

Is the inspection results normal?

YES >> GO TO 3.

NO >> Repair or replace harness or connectors.

#### 2. CHECK STEERING SWITCH RESISTANCE

---

Check steering switch resistance. Refer to [MWI-69, "Component Inspection"](#).

Is the inspection results normal?

YES >> GO TO 3.

NO >> Replace steering switch. Refer to [AV-49, "Removal and Installation"](#).

#### 3. CHECK SPIRAL CABLE

---

Check spiral cable for continuity. Refer to [SR-15, "Removal and Installation"](#).

Is the inspection results normal?

YES >> Replace combination meter. Refer to [MWI-81, "Removal and Installation"](#).

NO >> Replace spiral cable. Refer to [SR-15, "Removal and Installation"](#).

# THE AMBIENT TEMPERATURE DISPLAY IS INCORRECT

< SYMPTOM DIAGNOSIS >

## THE AMBIENT TEMPERATURE DISPLAY IS INCORRECT

### Description

INFOID:000000008702677

- The displayed ambient air temperature is higher than the actual temperature.
- The displayed ambient air temperature is lower than the actual temperature.

### Diagnosis Procedure

INFOID:000000008702678

#### 1.CHECK COMBINATION METER INPUT SIGNAL

1. Select METER/M&A on CONSULT.
2. Check OUTSIDE TEMP of DATA MONITOR.

Does the ambient temperature approximately match the CONSULT display?

- YES >> Replace combination meter. Refer to [MWI-81. "Removal and Installation"](#).  
NO >> GO TO 2.

#### 2.CHECK AMBIENT SENSOR SIGNAL CIRCUIT

Check the ambient sensor signal circuit. Refer to (without auto A/C) [MWI-65. "Diagnosis Procedure"](#) or (with auto A/C) [HAC-60. "Diagnosis Procedure"](#).

Is the inspection result normal?

- YES >> GO TO 3.  
NO >> Repair or replace harness or connectors.

#### 3.CHECK AMBIENT SENSOR

Check the ambient sensor. Refer to [MWI-66. "Component Inspection"](#).

Is the inspection result normal?

- YES >> Replace IPDM E/R. Refer to [PCS-32. "Removal and Installation"](#).  
NO >> Replace ambient sensor. Refer to [MWI-82. "Removal and Installation"](#).

A  
B  
C  
D  
E  
F  
G  
H  
I  
J  
K  
L  
M  
O  
P

MWI

# NORMAL OPERATING CONDITION

< SYMPTOM DIAGNOSIS >

## NORMAL OPERATING CONDITION COMPASS

### COMPASS : Description

INFOID:000000007985765

#### COMPASS

- The electronic compass is highly protected from changes in most magnetic fields. However, some large changes in magnetic fields can affect it. Some examples are (but not limited to): high tension power lines, large steel buildings, subways, steel bridges, automatic car washes, large piles of scrap metal, etc. While this does not happen very often, it is possible.
- During normal operation, the Compass Mirror will continuously update the compass calibration to adjust for gradual changes in the vehicle's magnetic "remnant" field. If the vehicle is subjected to high magnetic influences, the compass may appear to indicate false headings, become locked, or appear that it is unable to be calibrated. If this occurs, perform the calibration procedure.
- If at any time the compass continually displays the incorrect direction or the reading is erratic or locked, verify the correct zone variance.

#### Symptom Chart

Symptom	Cause	Solution / Reference
The compass display reads "C".	<ul style="list-style-type: none"> <li>• Compass is not calibrated.</li> <li>• Incorrect zone variance setting.</li> <li>• Large change in magnetic field (Steel bridges, subways, concentrations of metal, car washes, etc.)</li> <li>• Compass was calibrated incorrectly or in the presence of a strong magnetic field.</li> </ul>	Perform Calibration. Refer to <a href="#">MWI-16, "COMPASS : Description"</a> .
Compass shows the wrong direction.		
Compass does not change direction appears "Locked".		
Compass does not show all the directions, one or more is missing.		
The compass was calibrated but it "loses" calibration.		Perform Zone Variation Setting if correct reading is desired in that location. Refer to <a href="#">MWI-16, "COMPASS : Description"</a> .
On long trips the compass shows the wrong direction.		



# COMBINATION METER

< REMOVAL AND INSTALLATION >

## REMOVAL AND INSTALLATION

### COMBINATION METER

#### Removal and Installation

INFOID:000000007985768

#### REMOVAL

1. Disconnect the negative battery terminal.
2. Remove cluster lid A. Refer to [JP-19, "Removal and Installation"](#).
3. Remove the combination meter screws (A).
4. Pull out the combination meter (1).
5. Disconnect the harness connector from the combination meter (1) and remove the combination meter (1).

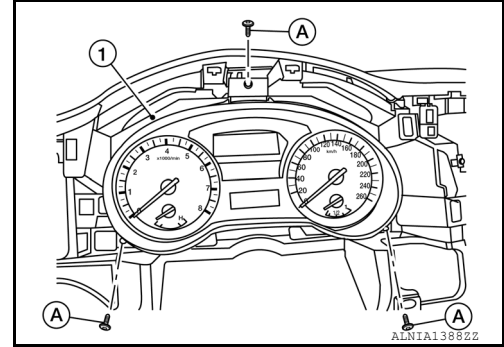

#### INSTALLATION

Installation is in the reverse order of removal.

A  
B  
C  
D  
E  
F  
G  
H  
I  
J  
K  
L  
M  
O  
P

MWI

# AMBIENT SENSOR

< REMOVAL AND INSTALLATION >

## AMBIENT SENSOR

### Removal and Installation

INFOID:000000008750377

#### REMOVAL

1. Remove the core support cover.
2. Disconnect the harness connector from the ambient sensor.
3. Release the ambient sensor clip, then remove the ambient sensor (1).

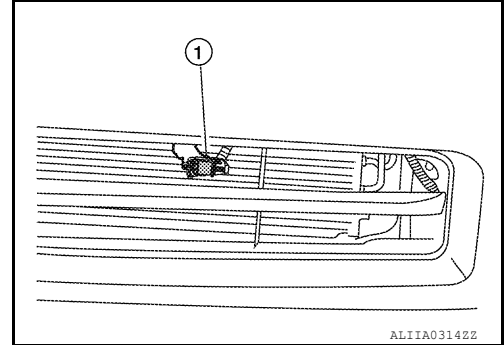

#### INSTALLATION

Installation is in the reverse order of removal.