

SECTION **PB**

PARKING BRAKE SYSTEM

A
B
C
D
E
PB
G
H
I
J
K
L
M
N
O
P

CONTENTS

PRECAUTION	2	Break-in Procedure	6
PRECAUTIONS	2	REMOVAL AND INSTALLATION	7
Precaution for Supplemental Restraint System (SRS) "AIR BAG" and "SEAT BELT PRE-TENSIONER"	2	PARKING BRAKE CONTROL	7
PREPARATION	3	Exploded View	7
PREPARATION	3	Removal and Installation	7
Commercial Service Tool	3	PARKING BRAKE SHOE	9
BASIC INSPECTION	4	Exploded View	9
PARKING BRAKE SYSTEM	4	Removal and Installation	9
Inspection	4	SERVICE DATA AND SPECIFICATIONS (SDS)	11
Adjustment	4	SERVICE DATA AND SPECIFICATIONS (SDS)	11
PARKING BRAKE SHOE	6	Parking Drum Brake	11
Inspection	6	Parking Brake Control	11

PRECAUTIONS

< PRECAUTION >

PRECAUTION

PRECAUTIONS

Precaution for Supplemental Restraint System (SRS) "AIR BAG" and "SEAT BELT PRE-TENSIONER"

INFOID:000000008748270

The Supplemental Restraint System such as "AIR BAG" and "SEAT BELT PRE-TENSIONER", used along with a front seat belt, helps to reduce the risk or severity of injury to the driver and front passenger for certain types of collision. Information necessary to service the system safely is included in the SR and SB section of this Service Manual.

WARNING:

- To avoid rendering the SRS inoperative, which could increase the risk of personal injury or death in the event of a collision which would result in air bag inflation, all maintenance must be performed by an authorized NISSAN/INFINITI dealer.
- Improper maintenance, including incorrect removal and installation of the SRS, can lead to personal injury caused by unintentional activation of the system. For removal of Spiral Cable and Air Bag Module, see the SR section.
- Do not use electrical test equipment on any circuit related to the SRS unless instructed to in this Service Manual. SRS wiring harnesses can be identified by yellow and/or orange harnesses or harness connectors.

PRECAUTIONS WHEN USING POWER TOOLS (AIR OR ELECTRIC) AND HAMMERS

WARNING:

- When working near the Airbag Diagnosis Sensor Unit or other Airbag System sensors with the Ignition ON or engine running, DO NOT use air or electric power tools or strike near the sensor(s) with a hammer. Heavy vibration could activate the sensor(s) and deploy the air bag(s), possibly causing serious injury.
- When using air or electric power tools or hammers, always switch the Ignition OFF, disconnect the battery and wait at least 3 minutes before performing any service.

PREPARATION



< PREPARATION >

PREPARATION

PREPARATION

Commercial Service Tool

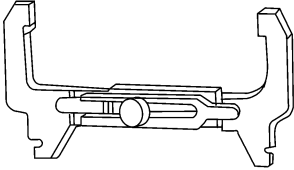
INFOID:000000007989032

(Kent-Moore No.) Tool name		Description
(J-21177-A) Brake drum clearance gauge	 <p style="text-align: center;">WFIA0167E</p>	Measuring rear rotor drum inner diameter
Power tool	 <p style="text-align: center;">PIIB1407E</p>	Loosening nuts, screws and bolts

A
B
C
D
E
PB
G
H
I
J
K
L
M
N
O
P

PARKING BRAKE SYSTEM

< BASIC INSPECTION >

BASIC INSPECTION

PARKING BRAKE SYSTEM

Inspection

INFOID:000000007989033

PEDAL STROKE

1. Operate parking brake pedal with a force of 196 N (20.0 kg-f, 44.1 lb-f), make sure pedal stroke is within the specified number of notches. (Check it by listening and counting ratchet clicks.)

Pedal stroke number of notches : Refer to [PB-11, "Parking Brake Control"](#).

2. When brake warning lamp turns ON, check that the pedal stroke is within the specified number of notches. (Check it by listening to the clicks of the ratchet.)

Standard

Number of notches : Refer to [PB-11, "Parking Brake Control"](#).

INSPECT COMPONENTS

- Make sure that the mounting conditions (looseness, backlash, etc.) of each component are normal.
- Check the following:
 - Device assembly for bend, damage and cracks. Replace if necessary.
 - Cables and equalizer for wear and damage. Replace if necessary.
 - Parking brake switch. Replace if necessary.

Adjustment

INFOID:000000007989034

ADJUSTMENT

1. Remove rear wheels and tires.
2. Insert a deep socket wrench onto adjusting nut. Rotate adjusting nut to fully loosen cable, and then release parking brake pedal.
3. Secure both disc rotors to hubs using wheel nuts so as not to tilt the disc rotors.

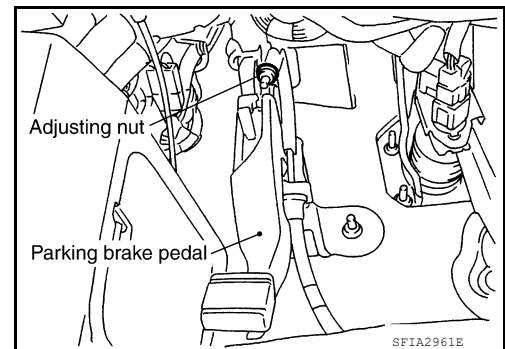

4. Remove both adjuster hole plugs installed on the disc rotors. Turn the adjusters in direction (A) using a suitable tool or a flat-bladed screwdriver as shown, until disc rotors are locked. Turn the adjusters in the opposite direction by 5 or 6 notches after locking.
5. Rotate the disc rotors to make sure that there is no drag. Install the adjuster hole plugs.
6. Adjust parking brake cable with the following procedure.
 - a. Rotate the adjusting nut to adjust parking brake pedal operating force to 490 N (50.0 kg-f, 110.2 lb-f) just before a full pedal stroke of 201.65 mm (7.94 in).

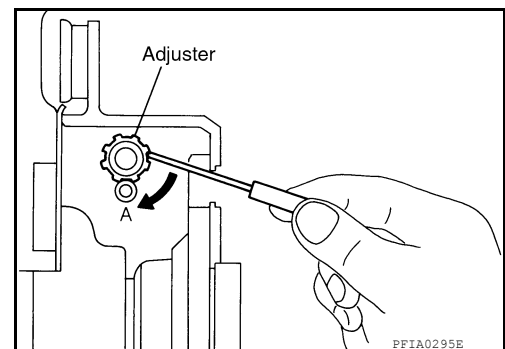

CAUTION:

Do not reuse adjusting nut after removing it.

- b. When replacing parking brake cable, operate parking brake pedal 10 or more times with a full stroke of 201.65 mm (7.94 in).
- c. Release the parking brake pedal and rotate the disc rotors to make sure there is no drag.

PARKING BRAKE SYSTEM

< BASIC INSPECTION >

- d. Rotate the adjusting nut to adjust the parking brake pedal force to 196 N (20.0 kg-f, 44.1 lb-f) when the parking brake pedal stroke is within the specified number of notches. (check it by listening and counting the ratchet clicks).

Pedal stroke number of notches : Refer to [PB-11, "Parking Brake Control"](#)

- e. After adjustment, check that there is no drag with the parking brake pedal is being released. If drag exists, perform the following:

- Remove the rear disc rotors, refer to [BR-34, "BRAKE CALIPER ASSEMBLY : Removal and Installation"](#). Verify the toggle pedals return to the stoppers when the parking brake lever is released.

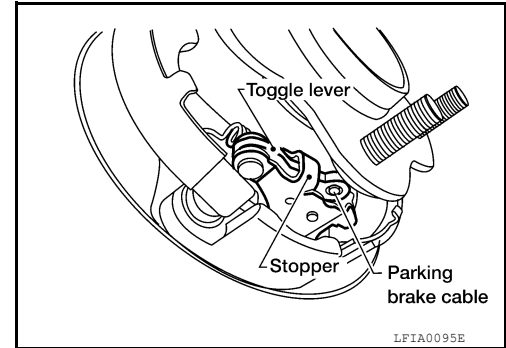

- If a toggle lever does not return to a stopper, loosen adjusting nut.
 - Install the rear disc rotor and adjust the shoe clearance. Refer to [BR-39, "BRAKE CALIPER ASSEMBLY : Removal and Installation"](#).
7. Install rear wheels and tires. Refer to [WT-52, "Adjustment"](#).

PARKING BRAKE SHOE

< BASIC INSPECTION >

PARKING BRAKE SHOE

Inspection

INFOID:000000007989037

LINING THICKNESS INSPECTION

- Check thickness of lining.

Standard thickness (new) (A) : Refer to [PB-11, "Parking Drum Brake"](#).

Wear limit thickness (A) : Refer to [PB-11, "Parking Drum Brake"](#).

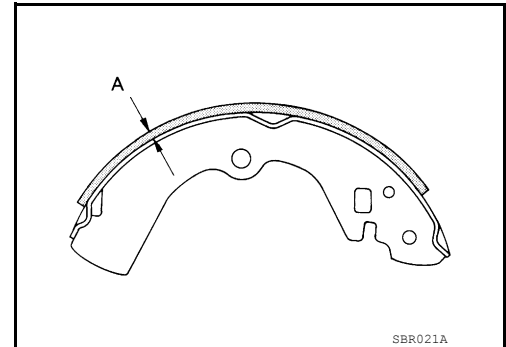

DRUM INNER DIAMETER INSPECTION

- Check inner diameter of drum in rear disc rotor using a suitable tool.

Standard inner diameter (new) : Refer to [PB-11, "Parking Drum Brake"](#).

Wear limit of inner diameter : Refer to [PB-11, "Parking Drum Brake"](#).

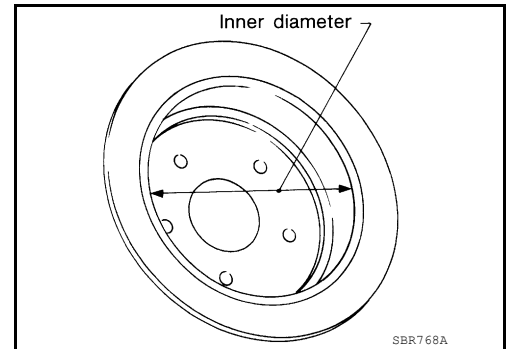

OTHER INSPECTIONS

- Check the following:
 - Lining for excessive wear, damage, and peeling.
 - Shoe sliding surface for excessive wear and damage.
 - Anti-rattle pin for excessive wear and corrosion.
 - Return spring for sagging.
- Make sure that adjuster moves smoothly.
- Visually check the inside of drum for excessive wear, cracks, and damage.
- Replace with new parts as necessary.

Break-in Procedure

INFOID:000000008707364

1. Perform parking brake break-in (drag run) operation by driving vehicle under the following conditions:
 - Drive the vehicle forward.
 - Maintain vehicle speed at approximately 40 km/h (25 MPH) keeping it constant in forward direction.
 - Apply the parking brake at the constant operating force specified. Approximately 200+49.0 Nm (20.4+5 kg-f, 45+11 lb-f).
 - Release the parking brake after approximately 5+5/-0 seconds.

CAUTION:
To prevent lining from getting too hot, allow a cool off period of approximately 5 minutes after every break-in operation.
2. Check parking brake control device assembly stroke.

CAUTION:
Readjust as necessary if it is outside the standard specifications. Refer to [PB-4, "Inspection"](#).

PARKING BRAKE CONTROL

< REMOVAL AND INSTALLATION >

REMOVAL AND INSTALLATION

PARKING BRAKE CONTROL

Exploded View

INFOID:000000007989038

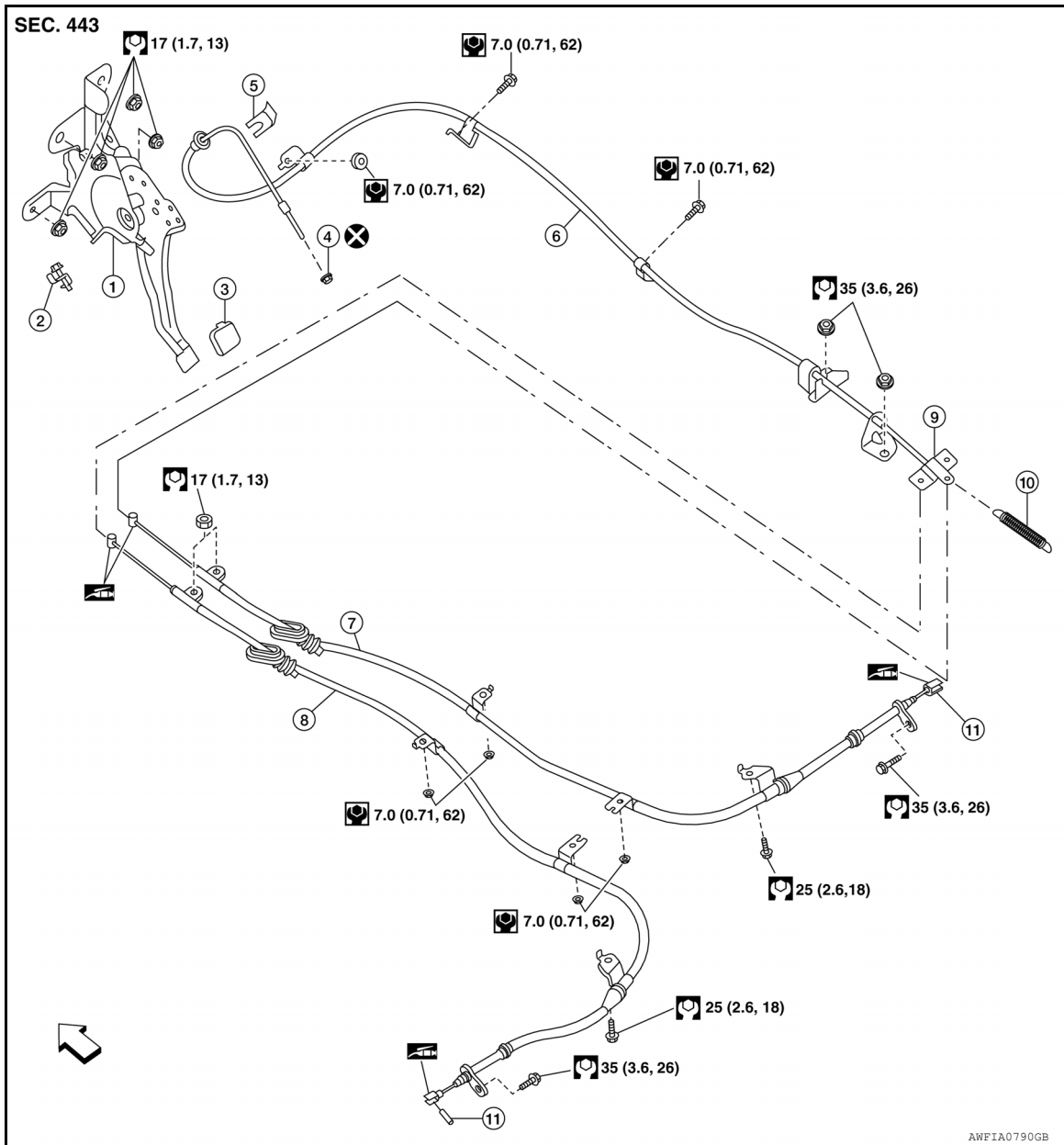

- | | | |
|---------------------------------|-------------------------|----------------|
| 1. Parking brake pedal assembly | 2. Parking brake switch | 3. Pedal pad |
| 4. Adjusting nut | 5. Lock plate | 6. Front cable |
| 7. Rear cable RH | 8. Rear cable LH | 9. Equalizer |
| 10. Spring | 11. Pin | ↔ Front |

Removal and Installation

INFOID:000000007989039

REMOVAL

1. Remove rear wheel and tires using power tool. Refer to [WT-52. "Adjustment"](#).
2. Remove instrument lower panel LH. Refer to [IP-21. "Removal and Installation"](#).

PARKING BRAKE CONTROL

< REMOVAL AND INSTALLATION >

3. Disconnect parking brake switch harness connector and remove parking brake switch.
4. Remove adjusting nut and discard, then loosen front cable.
CAUTION:
Do not reuse adjusting nut.
5. Disconnect front cable.
6. Remove parking brake pedal assembly nuts and remove parking brake pedal assembly.
7. Remove ITS control unit. Refer to [AV-413, "Removal and Installation"](#).
8. Remove spring and separate rear cables (LH and RH) from front cable, remove front cable.
9. Remove rear brake caliper and disc brake rotor. Refer to [BR-39, "BRAKE CALIPER ASSEMBLY : Removal and Installation"](#).
10. Remove parking brake shoe, and remove rear cable from toggle lever. Refer to [IP-14, "Exploded View"](#).
11. Remove rear cable bolts and nuts, then remove rear cables.

INSTALLATION

Installation is in the reverse order of removal.

- Adjust the parking brake with new adjusting nut. Refer to [WT-52, "Adjustment"](#).

CAUTION:

- **Do not reuse adjusting nut.**
- **The cables should be free from twists, damage, cracks or corrosion.**

PARKING BRAKE SHOE

< REMOVAL AND INSTALLATION >

PARKING BRAKE SHOE

Exploded View

INFOID:000000008753124

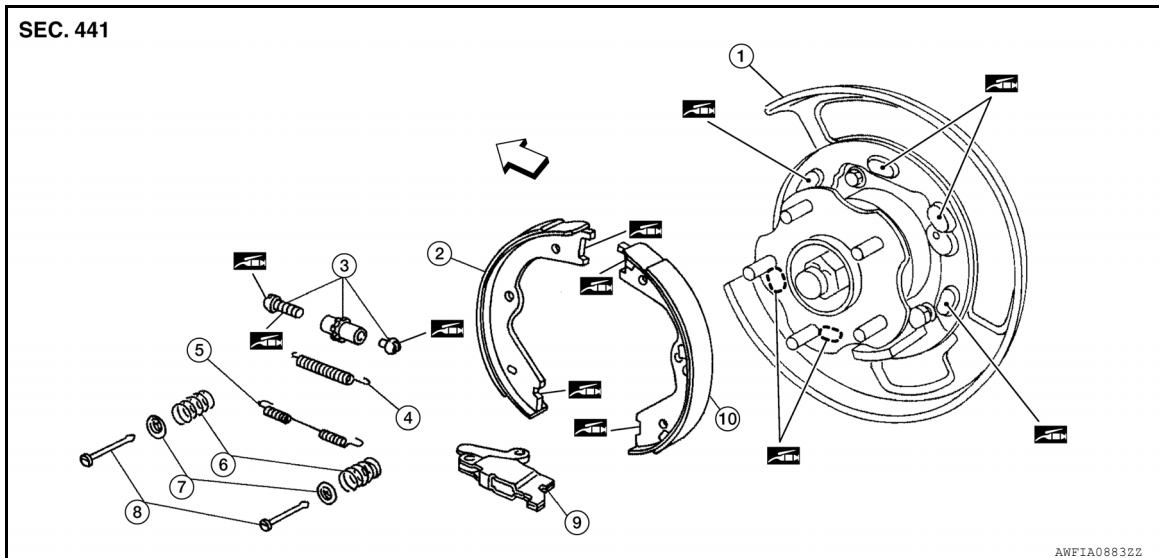

- | | | |
|-------------------------------|-------------------------------|---|
| 1. Back plate | 2. Parking brake shoe (front) | 3. Adjuster |
| 4. Adjuster spring | 5. Return spring | 6. Anti-rattle spring |
| 7. Retainer | 8. Anti-rattle pin | 9. Toggle lever |
| 10. Parking brake shoe (rear) | ← Front | Apply PBC (Poly Butyl Cuprysil) grease or silicone based grease |

Removal and Installation

INFOID:000000007989043

WARNING:

- Clean brakes with a vacuum dust collector to minimize the hazard of air borne particles or other materials.
- Clean dust on disc brake rotor and back plate using a vacuum dust collector. Do not blow with compressed air.

CAUTION:

Put matching marks on both disc brake rotor and wheel hub when removing disc rotor.

REMOVAL

1. Remove rear wheel and tires using power tool. Refer to [WT-52, "Adjustment"](#).
2. Remove rear brake caliper and disc brake rotor. Refer to [BR-39, "BRAKE CALIPER ASSEMBLY : Removal and Installation"](#).
3. If disc brake rotor cannot be removed, remove as follows:
 - a. Secure the disc brake rotor in place with wheel nuts and remove adjuster hole plug.
 - b. Rotate adjuster in direction (B) to retract and loosen brake shoe, using tool as shown.
 - c. Remove disc brake rotor.
4. Remove anti-rattle pins, retainers, anti-rattle springs, and return springs.
5. Remove parking brake shoes, adjuster assembly, and toggle lever.

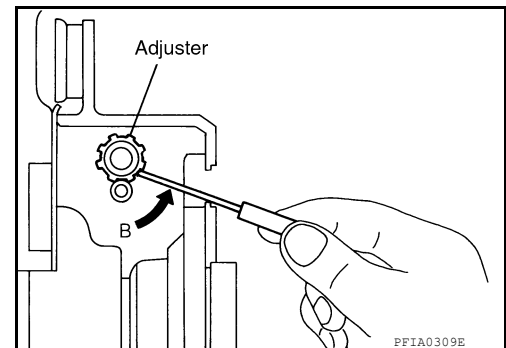

INSTALLATION

PARKING BRAKE SHOE

< REMOVAL AND INSTALLATION >

Installation is in the reverse order of removal. Note the following.

- Apply PBC (Poly Butyl Cuprysil) grease or silicone-based grease to the specified points during assembly.
- Assemble adjusters so that threaded part is expanded when rotating it in the direction shown.
- Shorten adjuster by rotating it as shown.
- Check shoe sliding surface and drum inner surface for grease. Wipe it off if it adhere on the surfaces.
- Perform break-in operation after replacing brake shoes or disc rotors, or if brakes do not function well. Refer to [PB-6. "Break-in Procedure"](#).
- Adjust parking brake pedal assembly stroke to the specified amount. Refer to [PB-11. "Parking Brake Control"](#).

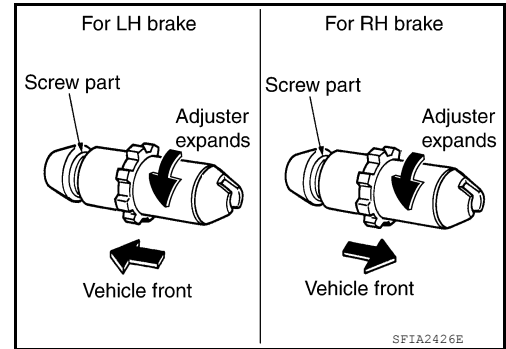

SERVICE DATA AND SPECIFICATIONS (SDS)

< SERVICE DATA AND SPECIFICATIONS (SDS)

SERVICE DATA AND SPECIFICATIONS (SDS)

SERVICE DATA AND SPECIFICATIONS (SDS)

Parking Drum Brake

INFOID:000000007989044

Unit: mm (in)

Brake lining	Standard thickness (new)	3.2 (0.126)
	Wear limit thickness	1.5 (0.059)
Drum (in disc)	Standard inner diameter (new)	172 (6.77)
	Wear limit of inner diameter	173 (6.81)

Parking Brake Control

INFOID:000000007989045

Control type	Foot pedal
Number of notches [under force of 196 N (20.0 kg-f, 44.1 lb-f)]	6 - 7
Number of notches when parking brake warning lamp switch comes on	1