

SECTION **FAX**  
FRONT AXLE

A  
B  
C

FAX

CONTENTS

<b>PRECAUTION</b> .....	2	<b>REMOVAL AND INSTALLATION</b> .....	8	F
<b>PRECAUTIONS</b> .....	2	<b>FRONT WHEEL HUB</b> .....	8	G
Precaution for Supplemental Restraint System (SRS) "AIR BAG" and "SEAT BELT PRE-TEN- SIONER" .....	2	Exploded View .....	8	
Precautions for Drive Shaft .....	2	Removal and Installation .....	8	
<b>PREPARATION</b> .....	3	<b>FRONT DRIVE SHAFT</b> .....	10	H
<b>PREPARATION</b> .....	3	Exploded View (LH) .....	10	
Special Service Tool .....	3	Removal and Installation (LH) .....	10	
Commercial Service Tool .....	3	Exploded View (RH) .....	12	I
<b>SYMPTOM DIAGNOSIS</b> .....	5	Removal and Installation (RH) .....	12	
<b>NOISE, VIBRATION, AND HARSHNESS (NVH) TROUBLESHOOTING</b> .....	5	<b>UNIT DISASSEMBLY AND ASSEMBLY</b> ...	15	J
NVH Troubleshooting Chart .....	5	<b>FRONT DRIVE SHAFT</b> .....	15	
<b>PERIODIC MAINTENANCE</b> .....	6	Disassembly and Assembly (LH) .....	15	
<b>FRONT WHEEL HUB</b> .....	6	Disassembly and Assembly (RH) .....	20	K
Inspection .....	6	<b>SERVICE DATA AND SPECIFICATIONS (SDS)</b> .....	27	L
<b>FRONT DRIVE SHAFT</b> .....	7	<b>SERVICE DATA AND SPECIFICATIONS (SDS)</b> .....	27	M
Inspection .....	7	Wheel Bearing .....	27	
		Drive Shaft .....	27	N
		Dynamic Damper .....	27	
		Boot Bands .....	28	O
				P

# PRECAUTIONS

< PRECAUTION >

## PRECAUTION

### PRECAUTIONS

#### Precaution for Supplemental Restraint System (SRS) "AIR BAG" and "SEAT BELT PRE-TENSIONER"

INFOID:000000009951700

The Supplemental Restraint System such as "AIR BAG" and "SEAT BELT PRE-TENSIONER", used along with a front seat belt, helps to reduce the risk or severity of injury to the driver and front passenger for certain types of collision. Information necessary to service the system safely is included in the SR and SB section of this Service Manual.

**WARNING:**

- To avoid rendering the SRS inoperative, which could increase the risk of personal injury or death in the event of a collision which would result in air bag inflation, all maintenance must be performed by an authorized NISSAN/INFINITI dealer.
- Improper maintenance, including incorrect removal and installation of the SRS, can lead to personal injury caused by unintentional activation of the system. For removal of Spiral Cable and Air Bag Module, see the SR section.
- Do not use electrical test equipment on any circuit related to the SRS unless instructed to in this Service Manual. SRS wiring harnesses can be identified by yellow and/or orange harnesses or harness connectors.

#### PRECAUTIONS WHEN USING POWER TOOLS (AIR OR ELECTRIC) AND HAMMERS

**WARNING:**

- When working near the Airbag Diagnosis Sensor Unit or other Airbag System sensors with the Ignition ON or engine running, DO NOT use air or electric power tools or strike near the sensor(s) with a hammer. Heavy vibration could activate the sensor(s) and deploy the air bag(s), possibly causing serious injury.
- When using air or electric power tools or hammers, always switch the Ignition OFF, disconnect the battery and wait at least three minutes before performing any service.

#### Precautions for Drive Shaft

INFOID:000000009464432

Observe the following precautions when disassembling and assembling drive shaft.

- Joint sub-assembly does not disassemble because it is non-overhaul parts.
- Perform work in a location which is as dust-free as possible.
- Before disassembling and assembling, clean the outside of parts.
- Prevention of the entry of foreign objects must be taken into account during disassembly of the service location.
- Disassembled parts must be carefully reassembled in the correct order. If work is interrupted, a clean cover must be placed over parts.
- Paper shop cloths must be used. Fabric shop cloths must not be used because of the danger of lint adhering to parts.
- Disassembled parts (except for rubber parts) should be cleaned with kerosene which shall be removed by blowing with air or wiping with paper shop cloths.

# PREPARATION

< PREPARATION >



## PREPARATION

### PREPARATION

#### Special Service Tool

INFOID:000000009464434

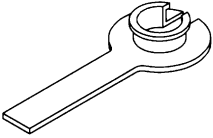
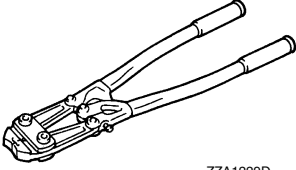
The actual shapes of the tools may differ from those illustrated here.

Tool number (TechMate No.) Tool name		Description
KV38106700 (J-34296) KV38106800 (J-34297) Differential side oil seal protector	  NT147	Installing drive shaft LH: KV38106700 (J-34296) RH: KV38106800 (J-34297)
KV40107300 ( — ) Boot Band crimping tool	  ZZA1229D	Installing boot bands
KV40107500 ( — ) Drive shaft attachment	  ZZA1230D	Removing drive shaft

#### Commercial Service Tool

INFOID:000000009464435

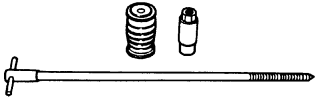
Tool name		Description
Drive shaft puller	  JPDIG0152ZZ	Removing drive shaft joint sub assembly

A  
B  
C  
E  
F  
G  
H  
I  
J  
K  
L  
M  
N  
O  
P

FAX

# PREPARATION

## < PREPARATION >

Sliding hammer

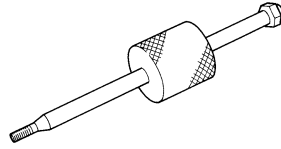

ZZA0023D

Removing drive shaft

Power tool



PIIB1407E

Loosening nuts, screws and bolts



## FRONT WHEEL HUB

< PERIODIC MAINTENANCE >

---

### PERIODIC MAINTENANCE

#### FRONT WHEEL HUB

##### Inspection

INFOID:000000009464436

- Move wheel hub and bearing assembly in the axial direction by hand. Make sure there is no looseness of wheel bearing.

**Axial end play** : Refer to [FAX-27, "Wheel Bearing"](#).

- Rotate wheel hub and make sure that is no unusual noise or other irregular conditions. If there is any of irregular conditions, replace wheel hub and bearing assembly

# FRONT DRIVE SHAFT

< PERIODIC MAINTENANCE >

## FRONT DRIVE SHAFT

---

### Inspection

INFOID:000000009464437

- Check drive shaft mounting point and joint for looseness and other damage.
- Check boot for cracks and other damage.

**CAUTION:**

**Replace entire drive shaft assembly when noise or vibration occur from drive shaft.**

A

B

C

FAX

E

F

G

H

I

J

K

L

M

N

O

P

# FRONT WHEEL HUB

< REMOVAL AND INSTALLATION >

## REMOVAL AND INSTALLATION

### FRONT WHEEL HUB

Exploded View

INFOID:000000009464438

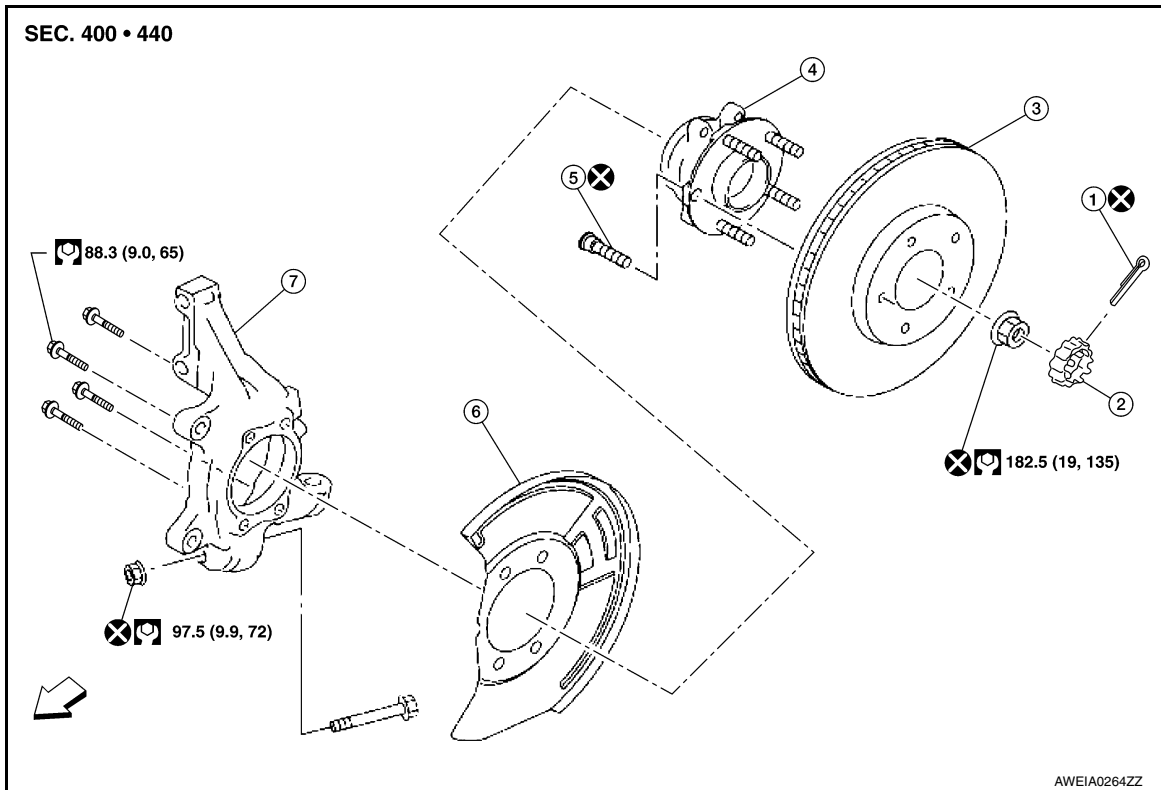

- |                                   |                   |                 |
|-----------------------------------|-------------------|-----------------|
| 1. Cotter pin                     | 2. Nut retainer   | 3. Rotor        |
| 4. Wheel hub and bearing assembly | 5. Wheel hub bolt | 6. Splash guard |
| 7. Steering knuckle               | ↩ Front           |                 |

## Removal and Installation

INFOID:000000009464439

### REMOVAL

1. Remove front wheel and tire using power tool. Refer to [WT-55. "Adjustment"](#).
2. Remove brake caliper using power tool, leaving brake caliper hydraulic hose attached. Position brake caliper aside with wire. Refer to [BR-36. "BRAKE CALIPER ASSEMBLY : Exploded View"](#).

#### CAUTION:

- Do not depress brake pedal while brake caliper is removed.
- Do not twist or stretch the brake hose.

3. Put alignment marks on disc rotor and wheel hub and bearing assembly, then remove disc rotor.

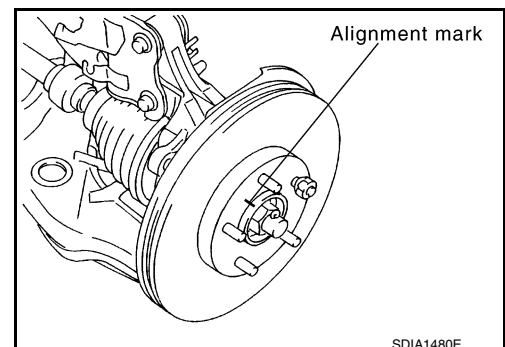



## FRONT WHEEL HUB

### < REMOVAL AND INSTALLATION >

4. Remove wheel sensor bolt (A) and wheel sensor from steering knuckle. Refer to [BRC-124, "Exploded View - Front Wheel Sensor"](#).

**CAUTION:**

Do not pull on wheel sensor harness.

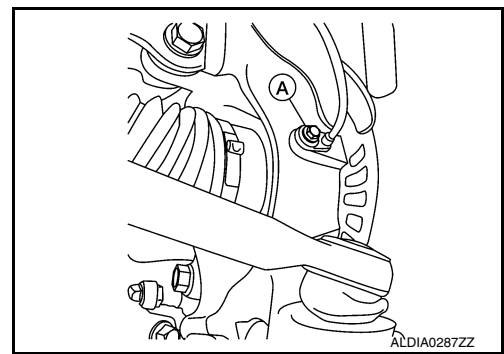

5. Remove and discard cotter pin.
6. Remove nut retainer.
7. Loosen lock nut from drive shaft using power tool.
8. Using a piece of wood and a hammer, tap on the lock nut to disengage drive shaft from wheel hub.

**CAUTION:**

- Do not place drive shaft joint to an extreme angle. Also be careful not to overextend slide joint.
- Do not allow drive shaft to hang down without support.

**NOTE:**

Use suitable puller if drive shaft cannot be separated from wheel hub and bearing assembly.

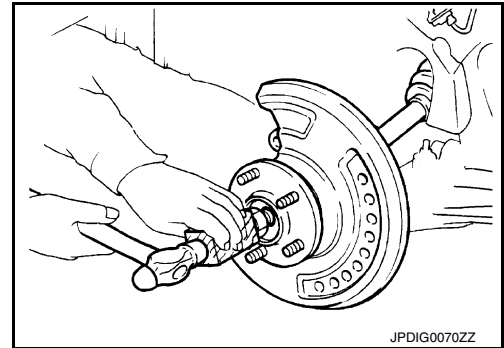

9. Remove wheel hub and bearing assembly bolts using power tool.
10. Remove splash guard and wheel hub and bearing assembly from steering knuckle.

### INSTALLATION

Installation is in the reverse order of removal.

**CAUTION:**

- Do not use a power tool to tighten the wheel hub lock nut.
- Do not reuse the cotter pin or the wheel hub lock nut.
- Do not apply lubricating oil to the mating surface.
- When installing wheel hub and bearing assembly to steering knuckle, align cutout in sensor rotor cover with wheel sensor mounting hole in steering knuckle.
- Align the marks made on the rotor and front wheel hub during disassembly.

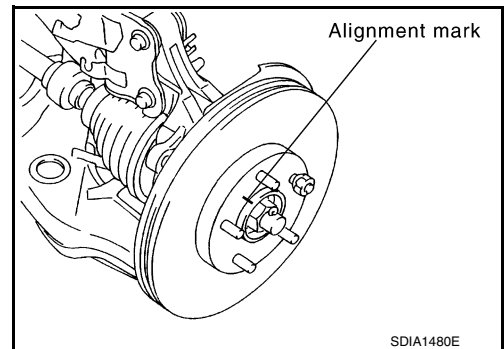

A  
B  
C  
FAX  
E  
F  
G  
H  
I  
J  
K  
L  
M  
N  
O  
P

# FRONT DRIVE SHAFT

< REMOVAL AND INSTALLATION >

## FRONT DRIVE SHAFT

Exploded View (LH)

INFOID:000000009464440

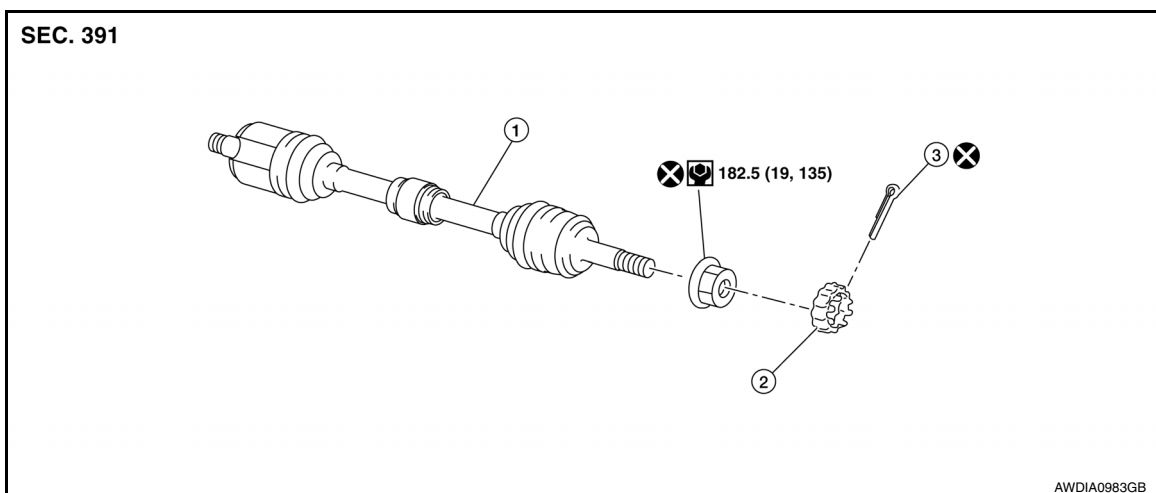

1. Drive shaft

2. Retainer

3. Cotter pin

## Removal and Installation (LH)

INFOID:000000009464441

### REMOVAL

1. Remove front wheel and tire using power tool. Refer to [WT-60, "Road Wheel"](#).
2. Remove wheel sensor bolt (A) and wheel sensor from steering knuckle. Refer to [BRC-127, "Removal and Installation - Front Sensor Rotor"](#).

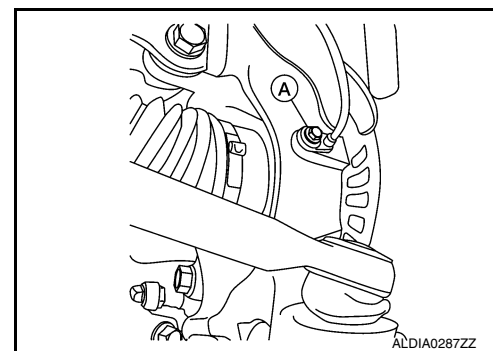

3. Remove brake hose retaining clip and brake hose from strut.
  4. Remove and discard cotter pin from drive shaft.
  5. Remove nut retainer from drive shaft.
  6. Loosen lock nut from drive shaft using power tool.
  7. Remove brake caliper using power tool, leaving hydraulic hose attached. Position brake caliper aside using wire. Refer to [BR-36, "BRAKE CALIPER ASSEMBLY : Removal and Installation"](#).
- CAUTION:**
- Do not twist or stretch the brake hose.
  - Do not depress brake pedal while brake caliper is removed.
8. Remove front strut to steering knuckle bolts and nuts, then separate front strut from steering knuckle. Refer to [FSU-9, "Removal and Installation"](#).

# FRONT DRIVE SHAFT

## < REMOVAL AND INSTALLATION >

9. Put alignment marks on disc rotor and wheel hub and bearing assembly, then remove disc rotor.

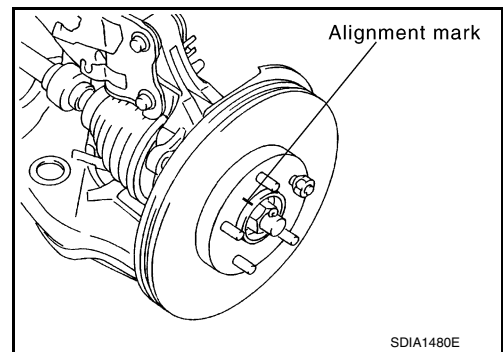

10. Using a piece of wood and a hammer, tap on the lock nut to disengage drive shaft from wheel hub.

**CAUTION:**

- Do not place drive shaft joint to an extreme angle. Also be careful not to overextend slide joint.
- Do not allow drive shaft to hang down without support.

**NOTE:**

Use suitable puller if drive shaft cannot be separated from wheel hub and bearing assembly.

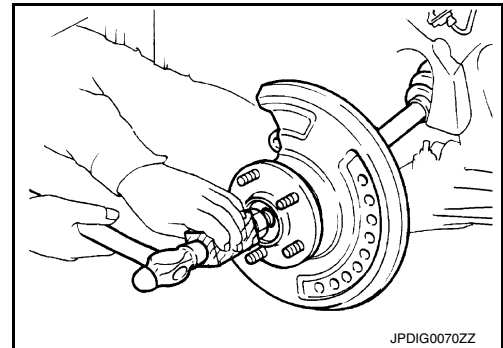

11. Remove the LH drive shaft from transaxle assembly.

- Remove drive shaft from transaxle using Tool and drive shaft puller or suitable tool.
- Set Tool and a drive shaft puller or suitable tool between drive shaft (slide joint side) and transaxle as shown, then remove drive shaft.

**Tool number** : KV40107500 ( — )

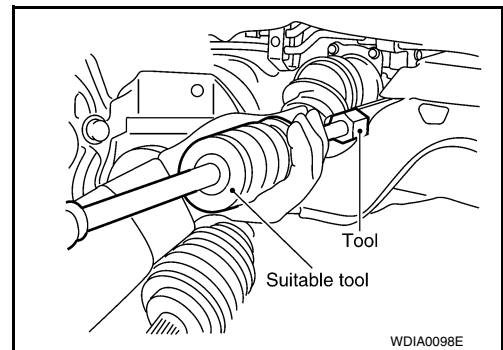

12. Remove the differential oil seal. Refer to [TM-197, "Removal and Installation"](#) (REOF10D), [TM-398, "Removal and Installation"](#) (REOF10E).

## INSTALLATION

Installation is in the reverse order of removal.

**CAUTION:**

- Do not use power tools to tighten the wheel hub lock nut.
- Do not reuse the cotter pin or the wheel hub lock nut.
- Install a new differential side oil seal. Refer to [TM-197, "Removal and Installation"](#) (REOF10D), [TM-398, "Removal and Installation"](#) (REOF10E).
- In order to prevent damage to differential oil seal, place Tool (A) onto oil seal before inserting drive shaft as shown.

**Tool number** : KV38106700 (J-34296)

- Install a new circlip on drive shaft in the circular clip groove on transaxle side. Refer to [FAX-15, "Disassembly and Assembly \(LH\)"](#).

**CAUTION:**

**Make sure the new circlip on the drive shaft is securely fastened.**

- Slide drive shaft into transaxle and tap with a hammer to install securely. After its insertion, try to pull the flange out of the slide joint by hand. If it pulls out, the circlip is not properly meshed with the transaxle side gear.
- Align the marks made on the rotor and front wheel hub during disassembly.

## INSPECTION AND ADJUSTMENT AFTER INSTALLATION

# FRONT DRIVE SHAFT

## < REMOVAL AND INSTALLATION >

1. Check CVT fluid level and leakage. Refer to [TM-84. "Adjustment"](#) (REOF10D), [TM-286. "Adjustment"](#) (REOF10E).
2. Check wheel alignment. Refer to [FSU-7. "Inspection and Adjustment"](#).
3. Adjust the neutral position of the steering angle sensor. Refer to [BRC-58. "Work Procedure"](#).

### Exploded View (RH)

INFOID:000000009464442

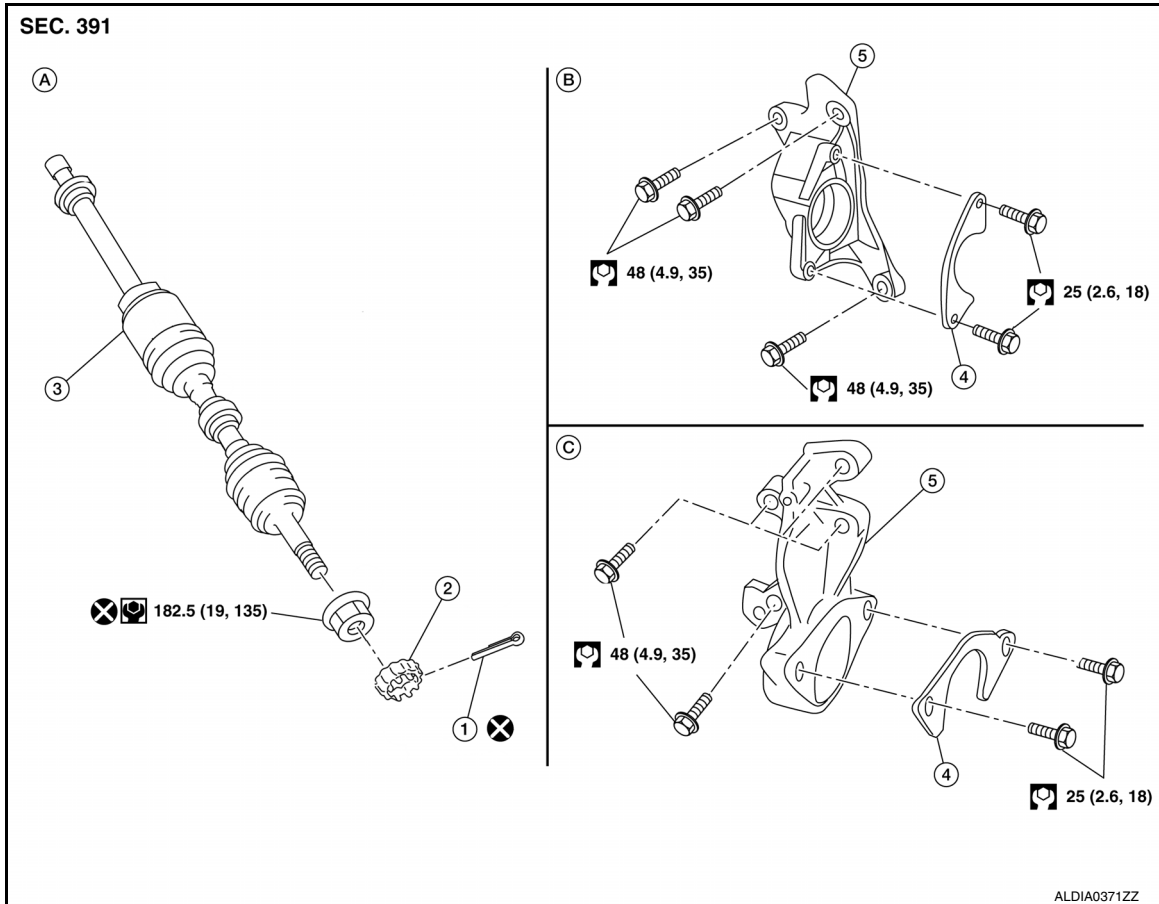

- |                      |                            |                         |
|----------------------|----------------------------|-------------------------|
| 1. Cotter pin        | 2. Retainer                | 3. Drive shaft          |
| 4. Retaining bracket | 5. Support bearing bracket | A. Front RH drive shaft |
| B. QR25DE engine     | C. VQ35DE engine           |                         |

### Removal and Installation (RH)

INFOID:000000009464443

#### REMOVAL

1. Remove front wheel and tire using power tool. Refer to [WT-60. "Road Wheel"](#).
2. Remove wheel sensor bolt (A) and wheel sensor from steering knuckle. Refer to [BRC-124. "Exploded View - Front Wheel Sensor"](#).

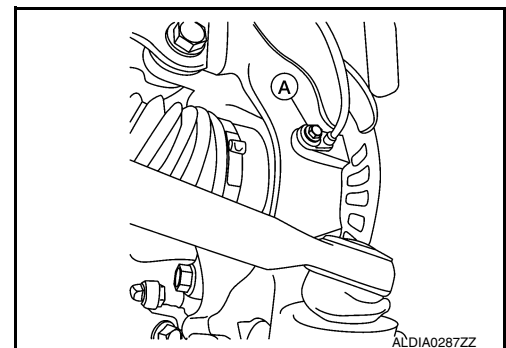

# FRONT DRIVE SHAFT

## < REMOVAL AND INSTALLATION >

3. Remove brake hose retaining clip and brake hose from strut.
4. Remove and discard cotter pin from drive shaft.
5. Remove nut retainer from drive shaft.
6. Loosen lock nut from drive shaft using power tool.
7. Remove brake caliper using power tool, leaving hydraulic brake hose attached. Position caliper aside using wire. Refer to [BR-36, "BRAKE CALIPER ASSEMBLY : Removal and Installation"](#).

**CAUTION:**

- Do not twist or stretch the brake hose.
- Do not depress brake pedal while brake caliper is removed.

8. Put alignment marks on disc rotor and wheel hub and bearing assembly, then remove disc rotor.

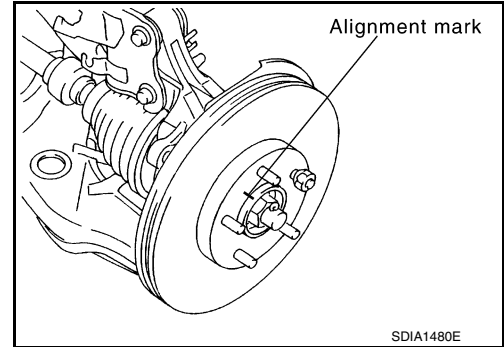

9. Remove front strut to steering knuckle bolts and nuts, then separate front strut from the steering knuckle. Refer to [FSU-9, "Removal and Installation"](#).

10. Using a piece of wood and a hammer, tap on the lock nut to disengage drive shaft from wheel hub.

**CAUTION:**

- Do not place drive shaft joint to an extreme angle. Also be careful not to overextend slide joint.
- Do not allow drive shaft to hang down without support.

**NOTE:**

Use suitable puller if drive shaft cannot be separated from wheel hub and bearing assembly.

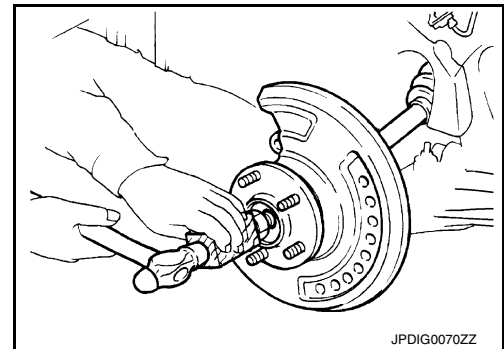

11. Remove retaining bracket to support bearing bracket bolts.

12. Remove RH drive shaft from transaxle assembly.

- Use Tool (A) and suitable tool (B) while inserting tip of tool between housing and transaxle assembly.

**CAUTION:**

Do not place drive shaft joint at an extreme angle when removing drive shaft. Do not overextend slide joint.

Tool number (A) : KV40107500 ( — )

13. Remove the differential side oil seal. Refer to [TM-197, "Removal and Installation"](#) (REOF10D), [TM-398, "Removal and Installation"](#) (REOF10E).

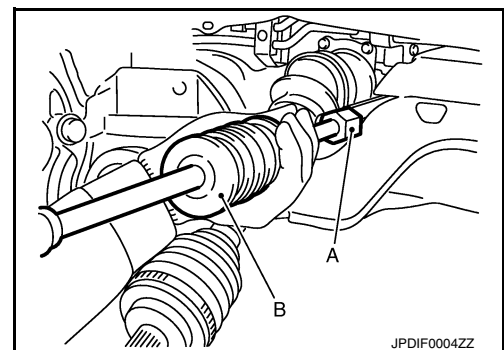

## INSTALLATION

Installation is in the reverse order of removal.

**CAUTION:**

- Do not use power tools to tighten wheel hub lock nut.
- Do not reuse the cotter pin or the wheel hub lock nut.
- Install a new differential side oil seal. Refer to [TM-197, "Removal and Installation"](#) (REOF10D), [TM-398, "Removal and Installation"](#) (REOF10E).

## FRONT DRIVE SHAFT

### < REMOVAL AND INSTALLATION >

- In order to prevent damage to differential side oil seal, place Tool (A) onto oil seal before inserting drive shaft as shown. Slide drive shaft into slide joint and tap with a hammer to install securely.

**Tool number : KV38106800 (J-34297)**

- Install new circlip on drive shaft in the circular clip groove on transaxle side. Refer to [FAX-20, "Disassembly and Assembly \(RH\)"](#).

**CAUTION:**

**Make sure the new circlip on the drive shaft is securely fastened.**

- After its insertion, try to pull the flange out of the slide joint by hand. If it pulls out, the circlip is not properly meshed with the transaxle side gear.
- For QR25DE models, install the retaining bracket with the notch facing up and follow the bolt tightening order.
- Align the marks made on rotor and front wheel hub and bearing.

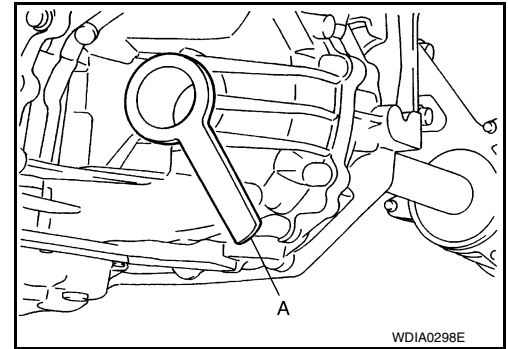

### INSPECTION AND ADJUSTMENT AFTER INSTALLATION

1. Check CVT fluid level and leakage. Refer to [TM-84, "Adjustment"](#) (REOF10D), [TM-286, "Adjustment"](#) (REOF10E).
2. Check wheel alignment. Refer to [FSU-7, "Inspection and Adjustment"](#).
3. Adjust the neutral position of the steering angle sensor. Refer to [BRC-58, "Work Procedure"](#).

# FRONT DRIVE SHAFT

< UNIT DISASSEMBLY AND ASSEMBLY >

## UNIT DISASSEMBLY AND ASSEMBLY

### FRONT DRIVE SHAFT

Disassembly and Assembly (LH)

INFOID:000000009464444

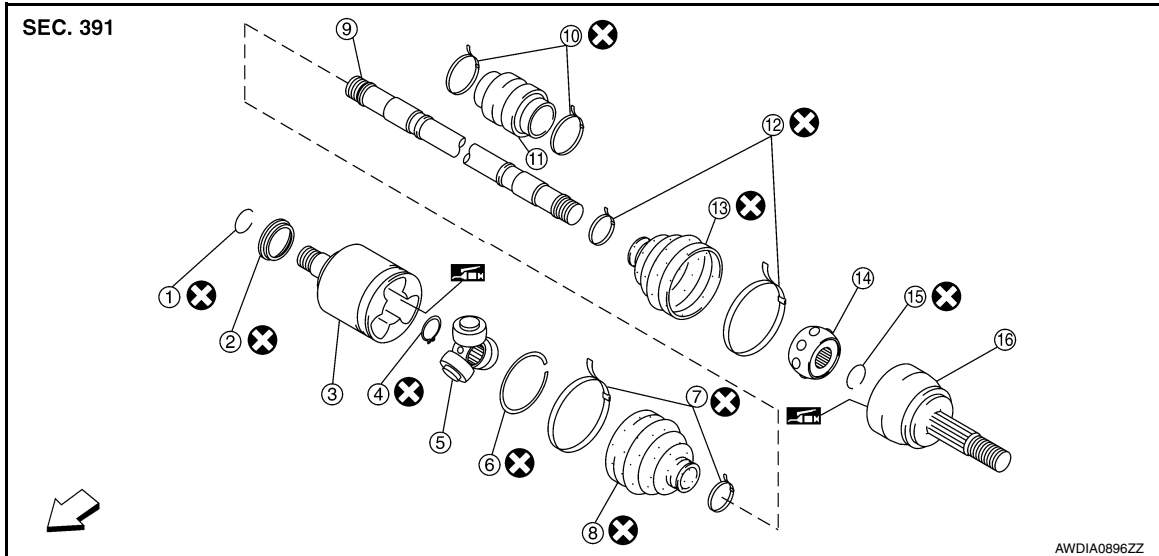

- |                        |  |                        |
|------------------------|--|------------------------|
| 1. Circlip             | 2. Dust shield                                   | 3. Slide joint housing |
| 4. Snap ring           | 5. Spider assembly                               | 6. Stopper ring        |
| 7. Boot band           | 8. Boot  | 9. Shaft               |
| 10. Damper band        | 11. Damper                                       | 12. Boot band          |
| 13. Boot               | 14. Ball cage / Steel ball / Inner race assembly | 15. Circlip            |
| 16. Joint sub-assembly | ⇐ Front  |                        |

### DISASSEMBLY

Transaxle Side

1. Mount front drive shaft in a vise.

**CAUTION:**

**When mounting shaft in a vise, always use copper or aluminum plates between vise and shaft.**

2. Remove boot bands and slide the boot back.
3. Remove circlip and dust shield from slide joint housing.
4. Put matching marks on slide joint housing and shaft before separating joint assembly.
5. Remove stopper ring with a suitable tool, then pull out slide joint housing.

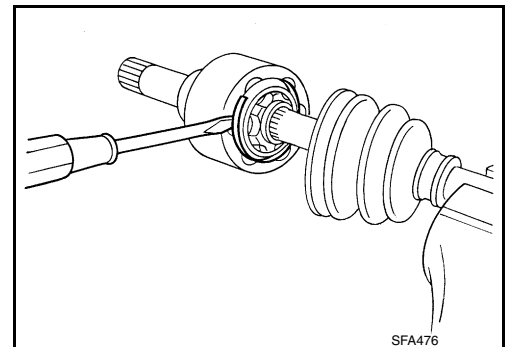



## FRONT DRIVE SHAFT

### < UNIT DISASSEMBLY AND ASSEMBLY >

- Put matching marks on spider assembly and shaft.

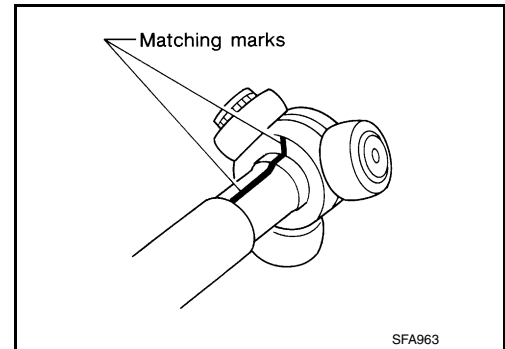

- Remove snap ring using a suitable tool, then remove spider assembly from shaft.
- Remove boot from shaft.
- Clean the old grease off of the slide joint assembly.

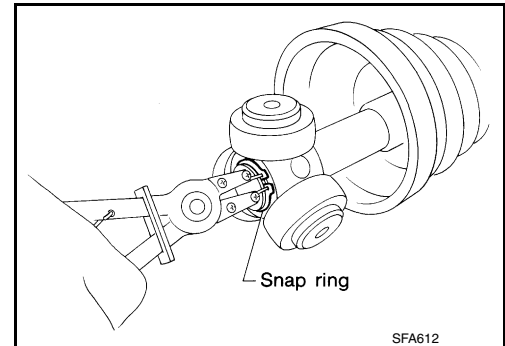

### Wheel Side

- Mount the front drive shaft in a vise.

#### **CAUTION:**

**When mounting shaft in a vise, always use copper or aluminum plates between vise and shaft.**

- Remove boot bands and slide the boot back.
- Screw a sliding hammer or suitable tool 30 mm (1.18 in) or more into threaded part of joint sub-assembly. Pull joint sub-assembly out of shaft.

#### **CAUTION:**

- Align sliding hammer or suitable tool and drive shaft then remove joint sub-assembly by pulling directly.
- If joint sub-assembly cannot be removed after five or more unsuccessful attempts, replace the entire drive shaft assembly.

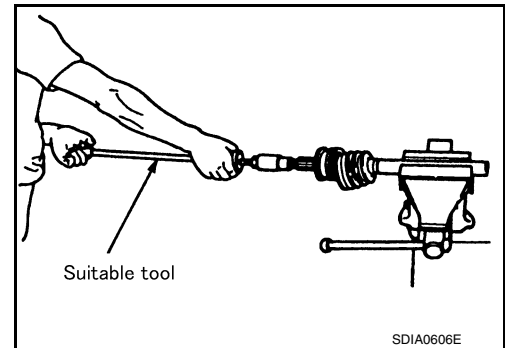

- Remove boot from shaft.
- Remove circlip from shaft.
- While rotating ball cage, clean the old grease off of the joint sub-assembly.

### Damper

- Remove damper bands, then remove damper from shaft.

### INSPECTION AFTER DISASSEMBLY

#### Shaft

- Replace shaft if there is bending, cracking, or other damage.

#### Joint Sub-Assembly

- Make sure there is no rough rotation or unusual axial looseness.
- Make sure there is no foreign material inside joint sub-assembly.
- Check joint sub-assembly for compression scars, cracks or fractures.

#### **CAUTION:**

**If there are any irregular conditions of joint sub-assembly components, replace the entire joint sub-assembly.**



# FRONT DRIVE SHAFT

## < UNIT DISASSEMBLY AND ASSEMBLY >

### Slide Joint Housing

- Make sure there are no compression scars, cracks or fractures or unusual wear of ball rolling surface.
- Make sure there is no damage to shaft screws.
- Make sure there is no deformation of boot installation parts.

### Ball Cage

- Make sure there are no compression scars, cracks, fractures of sliding surface.

### Steel Ball

- Make sure there are no compression scars, cracks, fractures or unusual wear.

### Inner Race

- Check ball sliding surface for compression scars, cracks or fractures.
- Make sure there is no damage to serrated part.

#### **CAUTION:**

**If there are any irregular conditions in the component, replace with a new set of joint sub-assembly, ball cage, steel ball and inner race.**

### Damper

- Check damper for cracks or wear. Install damper with new damper bands.

## ASSEMBLY

### Transaxle Side

1. Install new boot and new small boot band on shaft.

#### **CAUTION:**

- **Cover drive shaft serration with tape to prevent damage to boot during installation.**
- **Do not reuse boot band and boot.**

2. Remove protective tape wound around serrated part of shaft.

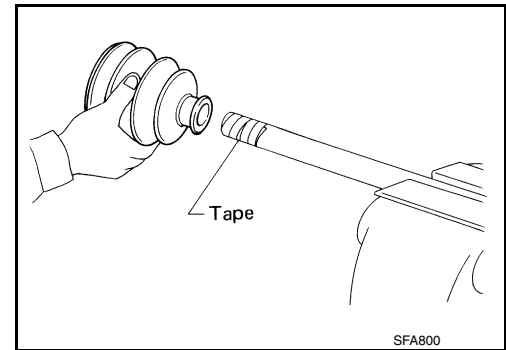

3. Install spider assembly securely, making sure the matching marks which were made during disassembly are properly aligned.

4. Install new snap ring using a suitable tool.

#### **CAUTION:**

**Do not reuse snap ring.**

5. Pack drive shaft with specified amount of new grease (Genuine NISSAN Grease or equivalent).

**Grease quantity** : Refer to [FAX-27, "Drive Shaft"](#)

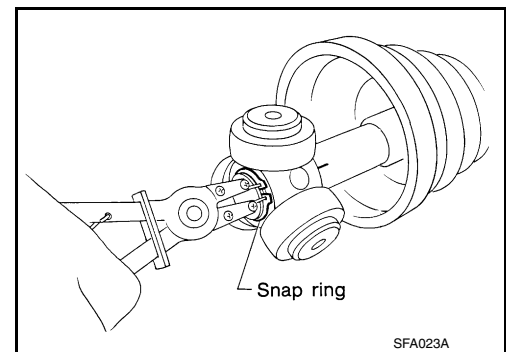

6. Install new stopper ring to housing of slide joint assembly.

#### **CAUTION:**

**Do not reuse stopper ring.**

7. After installation, pull shaft to check engagement between slide joint assembly and stopper ring.

A  
B  
C  
FAX  
E  
F  
G  
H  
I  
J  
K  
L  
M  
N  
O  
P

# FRONT DRIVE SHAFT

## < UNIT DISASSEMBLY AND ASSEMBLY >

8. Install boot securely into grooves (indicated by \* marks) as shown.

**CAUTION:**

If there is grease on boot mounting surfaces (indicated by \* marks) of shaft and housing, boot may come off. Clean all grease from surfaces.

9. Make sure boot installation length (L) is the length specified below. Insert a suitable tool into the large end of boot. Bleed air from boot to prevent boot deformation.

Boot installation length (L) : Refer to [FAX-27, "Drive Shaft"](#)

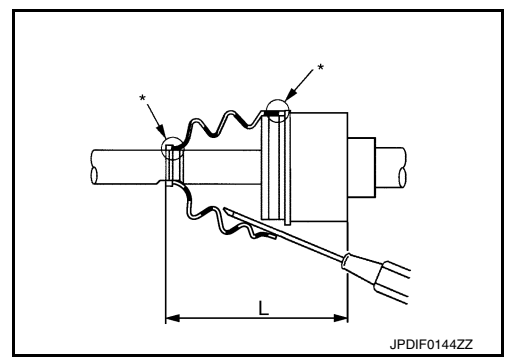

**CAUTION:**

- Boot may break if boot installation length is less than standard value.
- Be careful that suitable tool does not contact inside surface of boot.

10. Secure large and small ends of boot with new boot bands as shown.

**CAUTION:**

Do not reuse boot bands.

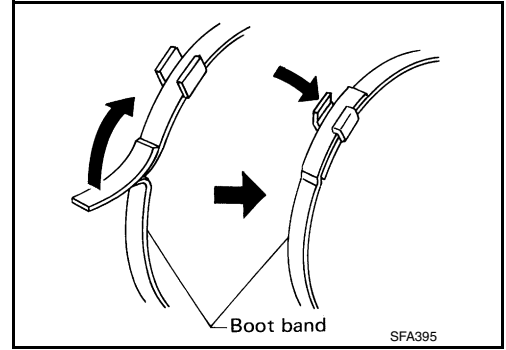

11. Install new dust shield to slide joint housing.

**CAUTION:**

Do not reuse dust shield.

12. After installing housing and shaft, make sure boot position is correct. If boot position is not correct, remove old boot bands then reposition the boot and secure with new boot bands.

### Wheel Side

1. Insert the amount of grease (Genuine NISSAN Grease or equivalent) into joint sub-assembly serration hole until grease begins to ooze from ball groove and serration hole. After inserting grease, use a shop cloth to wipe off old grease that has oozed out.

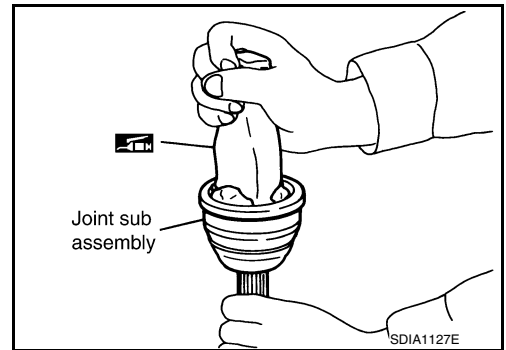

2. Cover serrated part of shaft with tape. Install new boot band and boot to shaft. Be careful not to damage boot.

**CAUTION:**

Do not reuse boot band and boot.

3. Remove protective tape wound around serrated part of shaft.

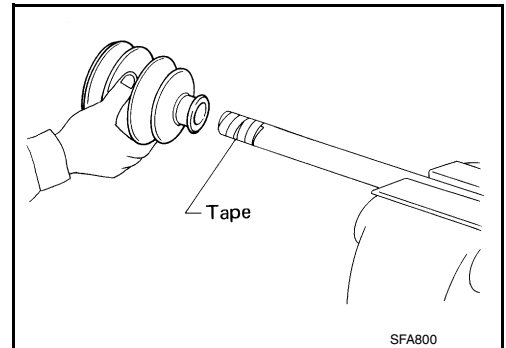

# FRONT DRIVE SHAFT

## < UNIT DISASSEMBLY AND ASSEMBLY >

- Attach new circlip to shaft. The circlip must fit securely into shaft groove. Attach nut to joint sub-assembly. Use a suitable tool to press-fit.

**CAUTION:**

**Do not reuse circlip.**

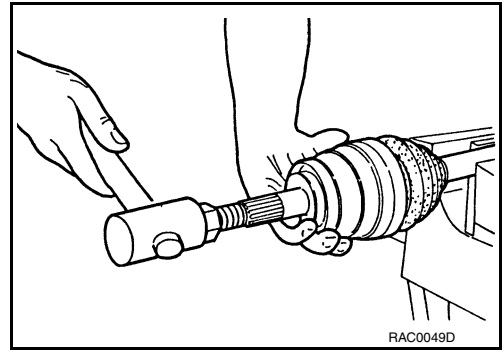

- Insert the amount of new grease (Genuine NISSAN Grease or equivalent) listed below into housing from large end of boot.

**Grease quantity** : Refer to [FAX-27, "Drive Shaft"](#)

- Install boot securely into grooves (indicated by \* marks) as shown.

**CAUTION:**

**If there is grease on boot mounting surfaces (indicated by \* marks) of shaft and housing, boot may come off. Remove all grease from surfaces.**

- Make sure boot installation length (L) is the specified length indicated below. Insert a suitable tool into the large end of boot. Bleed air from boot to prevent boot deformation.

**Boot installation length (L)**

: Refer to [FAX-27, "Drive Shaft"](#)

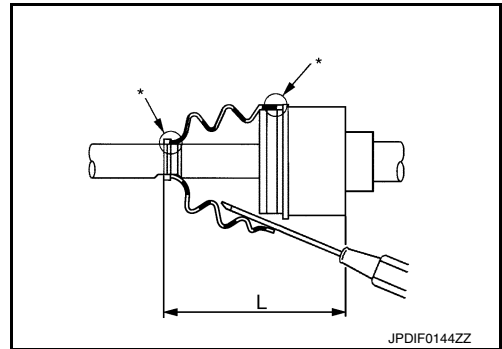

**CAUTION:**

- Boot may break if boot installation length is less than standard value.
- Be careful that suitable tool does not contact inside surface of boot.

- Install new large and small boot bands securely using Tool.

**Tool number** : KV40107300 ( — )

**CAUTION:**

- Do not reuse boot bands.

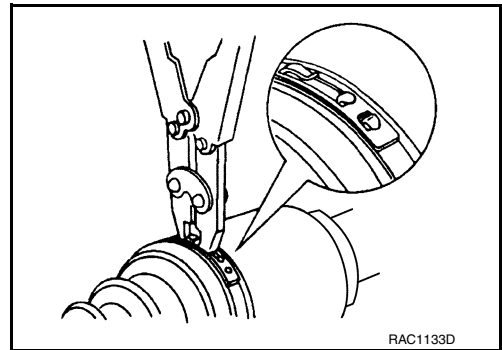

- Secure boot band so that dimension (M) meets specification as shown.

**Dimension (M)** : Refer to [FAX-28, "Boot Bands"](#).

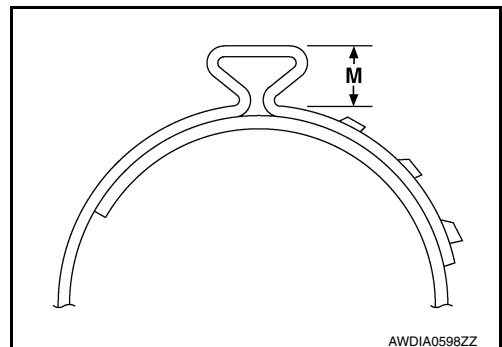

- After installing housing and shaft, rotate boot to check whether or not the actual position is correct. If boot position is not correct, remove old boot bands then reposition the boot and secure with new boot bands.

A  
B  
C  
FAX  
E  
F  
G  
H  
I  
J  
K  
L  
M  
N  
O  
P

# FRONT DRIVE SHAFT

## < UNIT DISASSEMBLY AND ASSEMBLY >

### Damper

1. Use new damper bands for installation.  
**CAUTION:**  
**Do not reuse damper bands.**
2. Install damper from stationary-joint side while holding it securely.

**Dimension (A)** : Refer to [FAX-27, "Dynamic Damper"](#)

**Dimension (B)** : Refer to [FAX-27, "Dynamic Damper"](#)

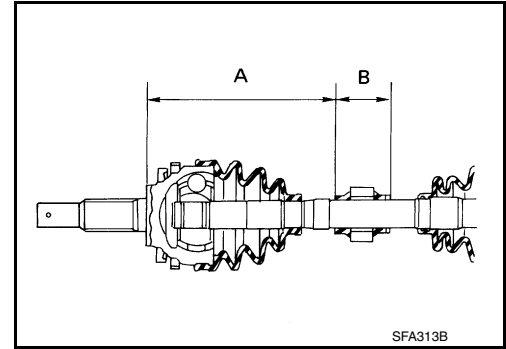

### Disassembly and Assembly (RH)

INFOID:000000009464445

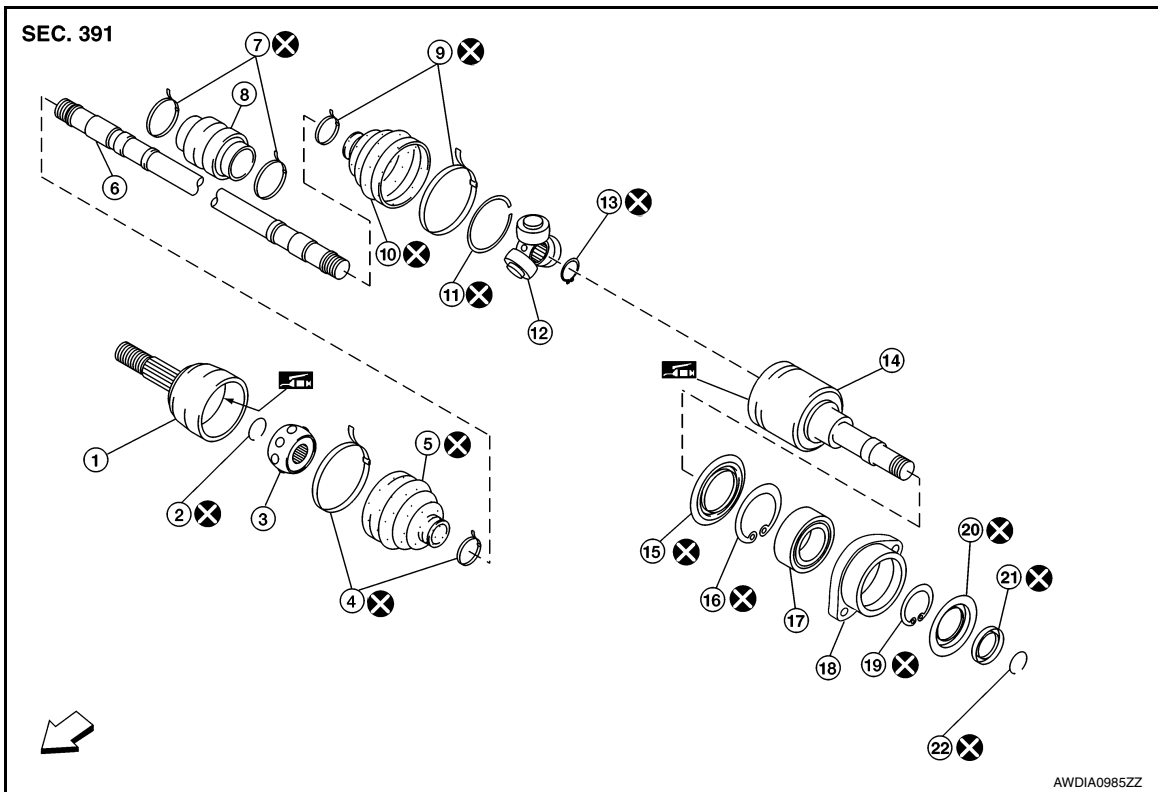

- |                       |                         |   |
|-----------------------|-------------------------|---|
| 1. Joint sub-assembly | 2. Circlip              | 3. Ball cage / Steel ball / Inner race assembly |
| 4. Boot bands         | 5. Boot                 | 6. Shaft  |
| 7. Damper bands       | 8. Damper               | 9. Boot band                                    |
| 10. Boot              | 11. Stopper ring        | 12. Spider assembly                             |
| 13. Snap ring         | 14. Slide joint housing | 15. Dust cover                                  |
| 16. Snap ring         | 17. Bearing             | 18. Retaining bracket                           |
| 19. Snap ring         | 20. Dust shield         | 21. Dust shield                                 |
| 22. Circlip           | ⇐ Front                 |   |

### DISASSEMBLY

#### Transaxle Side

1. Mount shaft in a vise.  
**CAUTION:**  
**When mounting shaft in a vise, always use copper or aluminum plates between vise and shaft.**
2. Remove circlip and dust shield from slide joint housing.

## FRONT DRIVE SHAFT

### < UNIT DISASSEMBLY AND ASSEMBLY >

3. Remove boot bands and slide the boots back.
4. Put matching marks on slide joint housing and shaft before separating slide joint housing.
5. Remove stopper ring using a suitable tool, then pull out slide joint housing.

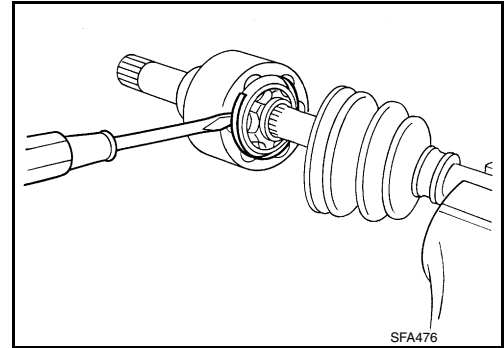

6. Put matching marks on spider assembly and shaft.

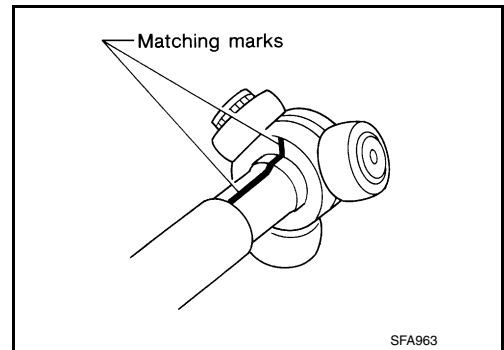

7. Remove snap ring using a suitable tool, then remove spider assembly from shaft.
8. Remove boot from shaft.
9. Clean old grease off of the slide joint housing.

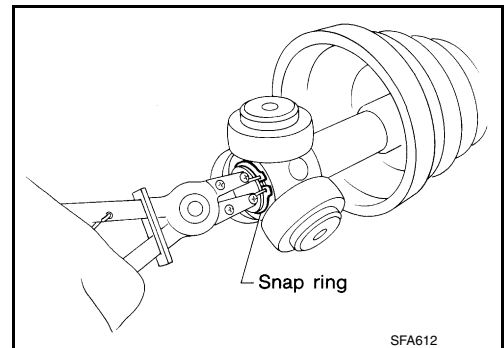

### Wheel Side

1. Mount the front drive shaft in a vise.

#### **CAUTION:**

**When mounting shaft in a vise, always use copper or aluminum plates between vise and shaft.**

2. Remove boot bands and slide the boot back.
3. Screw a sliding hammer or suitable tool 30 mm (1.18 in) or more into threaded part of joint sub-assembly. Pull joint sub-assembly out of shaft.

#### **CAUTION:**

- **Align sliding hammer or suitable tool and drive shaft then remove joint sub-assembly by pulling directly.**
- **If joint sub-assembly cannot be removed after five or more unsuccessful attempts, replace the entire drive shaft assembly.**

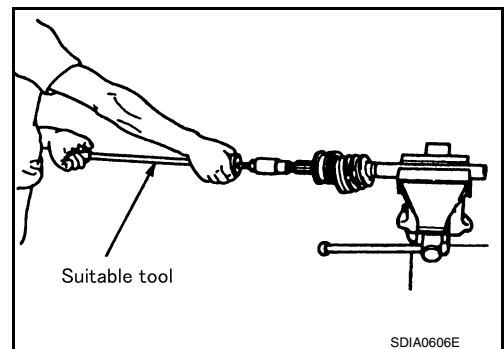

4. Remove boot from shaft.
5. Remove circlip from shaft.
6. While rotating ball cage, clean the old grease off of the joint sub-assembly.

A  
B  
C  
FAX  
E  
F  
G  
H  
I  
J  
K  
L  
M  
N  
O  
P

# FRONT DRIVE SHAFT

## < UNIT DISASSEMBLY AND ASSEMBLY >

### Support Bearing

1. Remove dust shield from slide joint assembly using a suitable tool.

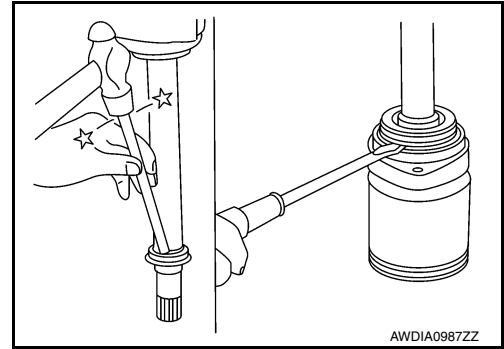

2. Remove snap ring (A) using a suitable tool.

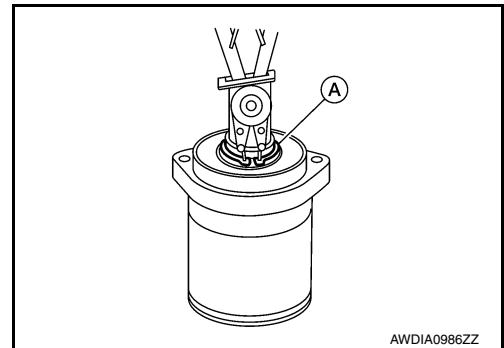

3. Press support bearing assembly off slide joint assembly using a suitable tool.

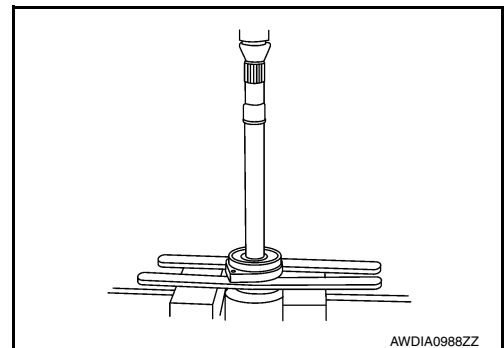

### Damper

- Remove damper bands, then remove damper from shaft.

## INSPECTION AFTER DISASSEMBLY

### Shaft

- Replace shaft if there is any bending, cracking, or other damage.

### Joint Sub-assembly

- Make sure there is no rough rotation or unusual axial looseness.
- Make sure there is no foreign material inside joint sub-assembly.
- Check joint sub-assembly for compression scars, cracks or fractures.

### **CAUTION:**

**If there are any irregular conditions of joint sub-assembly components, replace the entire joint sub-assembly.**

### Sliding Joint Housing and Spider Assembly

- If roller surface of spider assembly has scratches or wear, replace housing and spider assembly.

### **NOTE:**

Housing and spider assembly are components which are used as a set.

### Support Bearing

- Make sure wheel bearing rolls freely and is free from noise, cracks, pitting or wear.

### Damper

# FRONT DRIVE SHAFT

## < UNIT DISASSEMBLY AND ASSEMBLY >

- Check damper for cracks or wear. Install damper with new damper bands.

### ASSEMBLY

#### Transaxle Side

1. Cover serrated part of shaft with tape. Install new boot and boot band onto shaft. Be careful not to damage boot.

**CAUTION:**

**Do not reuse boot band and boot.**

2. Remove protective tape wound around serrated part of shaft.

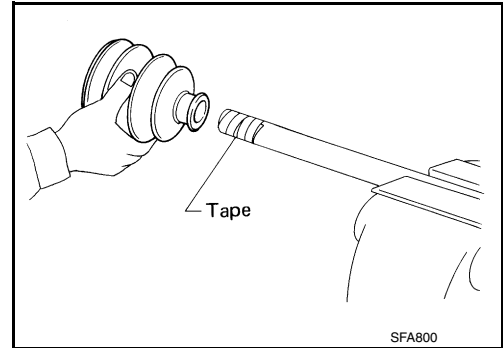

3. Install spider assembly securely, making sure the matching marks which were made during disassembly are properly aligned.

4. Install new snap ring using a suitable tool.

**CAUTION:**

**Do not reuse snap ring.**

5. Pack drive shaft with specified amount of grease (Genuine NIS-SAN Grease or equivalent).

**Grease quantity** : Refer to [FAX-27, "Drive Shaft"](#)

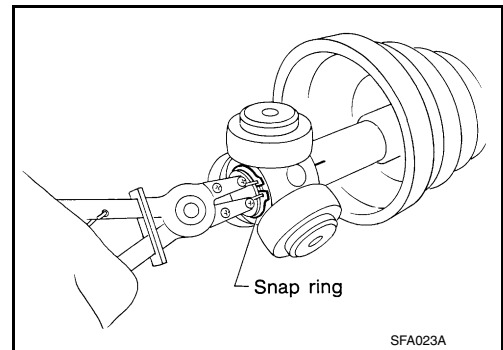

6. Install new stopper ring to slide joint assembly.

**CAUTION:**

**Do not reuse stopper ring.**

7. After installation, pull shaft to check engagement between slide joint assembly and stopper ring.

8. Install boot securely into grooves (indicated by \* marks) as shown.

**CAUTION:**

**If there is grease on boot mounting surfaces (indicated by \* marks) of shaft and housing, boot may come off. Remove all grease from surfaces.**

9. Make sure boot installation length (L) is the length indicated below. Insert a suitable tool into the large end of boot. Bleed air from boot to prevent boot deformation.

**Boot installation length (L)** : Refer to [FAX-27, "Drive Shaft"](#)

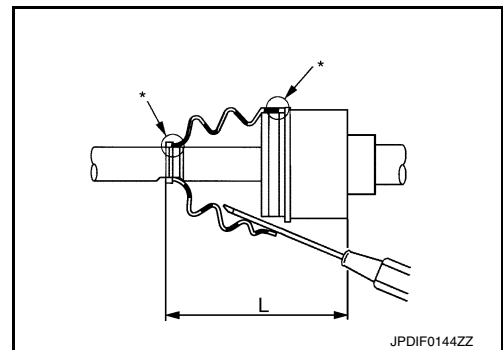

**CAUTION:**

- Boot may break if boot installation length is less than standard value.
- Be careful that suitable tool does not contact inside surface of boot.

A  
B  
C  
FAX  
E  
F  
G  
H  
I  
J  
K  
L  
M  
N  
O  
P

## FRONT DRIVE SHAFT

### < UNIT DISASSEMBLY AND ASSEMBLY >

- Secure big and small ends of boot with new boot bands as shown.

**CAUTION:**

**Do not reuse boot bands.**

- Install new dust shield to slide joint housing.

**CAUTION:**

**Do not reuse dust shield.**

- After installing housing and shaft, rotate boot to check whether or not the actual position is correct. If boot position is not correct, remove old boot bands then reposition the boot and secure with new boot bands.

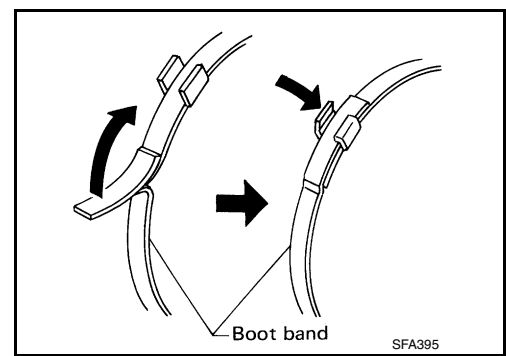

### Wheel Side

- Insert the amount of grease (Genuine NISSAN Grease or equivalent) into joint sub-assembly serration hole until grease begins to ooze from ball groove and serration hole. After inserting grease, use a shop cloth to wipe off old grease that has oozed out.

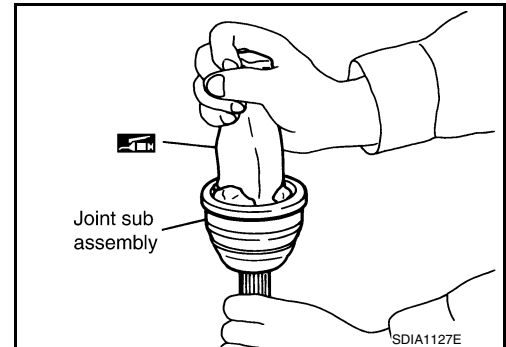

- Cover serrated part of shaft with tape. Install new boot and boot band onto shaft. Be careful not to damage boot.

**CAUTION:**

**Do not reuse boot band and boot.**

- Remove protective tape wound around serrated part of shaft.

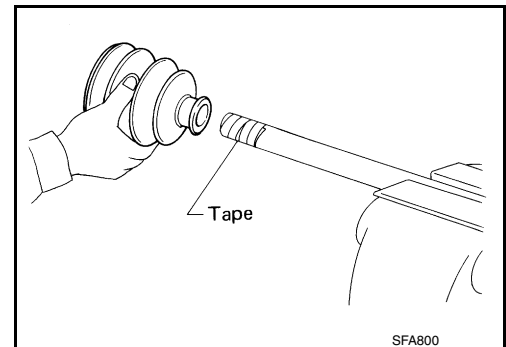

- Attach new circlip to shaft. The circlip must fit securely into shaft groove. Attach nut to joint sub-assembly.

Use a suitable tool to press-fit.

**CAUTION:**

**Do not reuse circlip.**

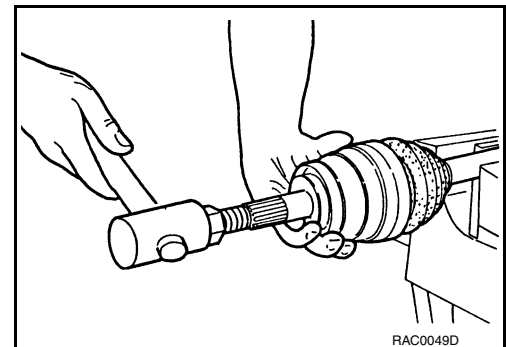

- Insert the amount of new grease (Genuine NISSAN Grease or equivalent) listed below into housing from large end of boot.

**Grease quantity** : Refer to [FAX-27, "Drive Shaft"](#)



# FRONT DRIVE SHAFT

## < UNIT DISASSEMBLY AND ASSEMBLY >

6. Install boot securely into grooves (indicated by \* marks) as shown.

**CAUTION:**

If there is grease on boot mounting surfaces (indicated by \* marks) of shaft and housing, boot may come off. Remove all grease from surfaces.

7. Make sure boot installation length (L) is the specified length. Insert a suitable tool into the large end of boot. Bleed air from boot to prevent boot deformation.

**Boot installation length (L) : Refer to [FAX-27, "Drive Shaft"](#)**

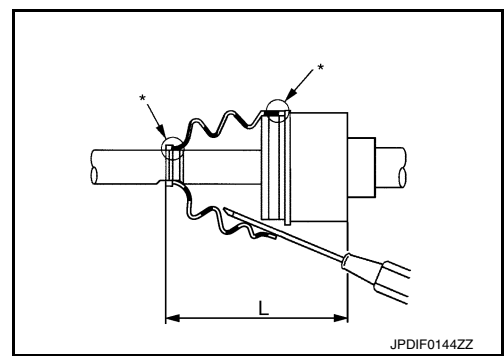

**CAUTION:**

- Boot may break if boot installation length is less than standard value.
- Be careful that suitable tool does not contact inside surface of boot.

8. Install new large and small boot bands securely using Tool.

**Tool number : KV40107300 ( — )**

**CAUTION:**

- Do not reuse boot bands.

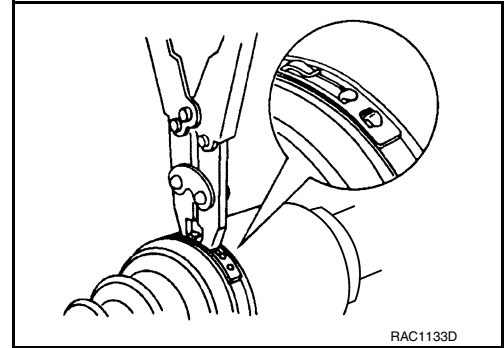

- Secure boot band so that dimension (M) meets specification as shown.

**Dimension (M) : Refer to [FAX-28, "Boot Bands"](#).**

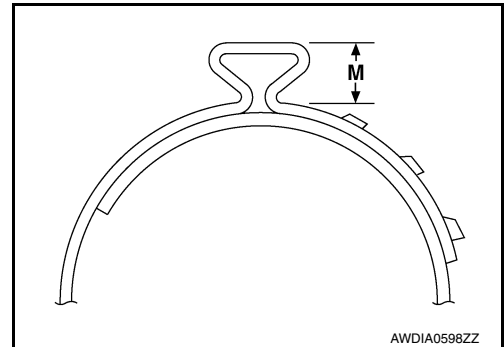

9. After installing housing and shaft, rotate boot to check whether or not the actual position is correct. If boot position is not correct, remove old boot bands then reposition the boot and secure with new boot bands.

### Support Bearing

1. With QR25DE engine, press support bearing into retaining bracket using a suitable tool.
2. Install support bearing onto slide joint assembly.
3. Install snap ring.

**CAUTION:**

**Do not reuse snap ring.**

4. Install dust shield.

**CAUTION:**

**Do not reuse dust shield.**

### Damper

A  
B  
C  
FAX  
E  
F  
G  
H  
I  
J  
K  
L  
M  
N  
O  
P

## FRONT DRIVE SHAFT

### < UNIT DISASSEMBLY AND ASSEMBLY >

1. Use new damper bands for installation.  
**CAUTION:**  
**Do not reuse damper bands.**
2. Install damper from stationary-joint side while holding it securely.

**Dimension (A)** : Refer to [FAX-27, "Dynamic Damper"](#).

**Dimension (B)** : Refer to [FAX-27, "Dynamic Damper"](#).

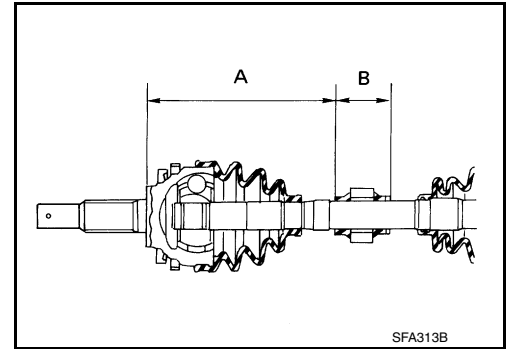

# SERVICE DATA AND SPECIFICATIONS (SDS)

< SERVICE DATA AND SPECIFICATIONS (SDS)

## SERVICE DATA AND SPECIFICATIONS (SDS)

### SERVICE DATA AND SPECIFICATIONS (SDS)

#### Wheel Bearing

INFOID:000000009464446

Axial end play limit	0.05 mm (0.002 in) or less
----------------------	----------------------------

#### Drive Shaft

INFOID:000000009464447

A  
B  
C  
FAX  
E  
F  
G  
H  
I  
J  
K  
L  
M  
N  
O  
P

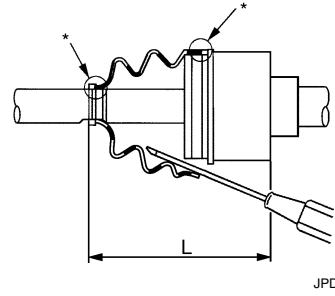
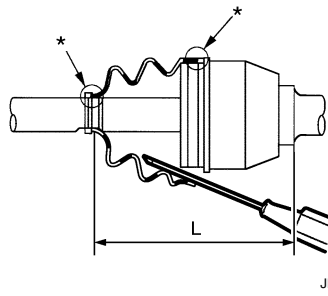

Application	QR25DE			
Joint type	Wheel side		Transaxle side	
	LH	RH	LH	RH
Grease quantity	115 ± 10 g (4.06 ± 0.35 oz)	115 ± 10 g (4.06 ± 0.35 oz)	159.5 ± 6.5 g (5.63 ± 0.23 oz)	159.5 ± 6.5 g (5.63 ± 0.23 oz)
Boots installed length	142.2 mm (5.26 in)	142.2 mm (5.26 in)	176.7 mm (6.96 in)	168.7 mm (6.64 in)

  

Application	VQ35DE			
Joint type	Wheel side		Transaxle side	
	LH	RH	LH	RH
Grease quantity	115 ± 5 g (4.06 ± 0.18 oz)	115 ± 5 g (4.06 ± 0.18 oz)	139 ± 5 g (4.90 ± 0.18 oz)	139 ± 5 g (4.90 ± 0.18 oz)
Boots installed length	146.7 mm (6.36 in)	146.7 mm (6.36 in)	166.7 mm (6.56 in)	166.7 mm (6.56 in)

\* : Boot installation grooves

#### Dynamic Damper

INFOID:000000009464448

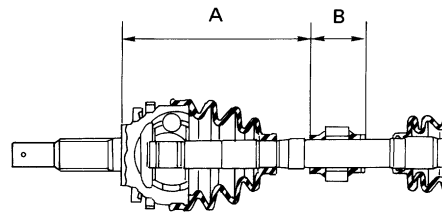

	QR25DE	
	LH	RH
Dimension (A)	230 ± 3 mm (9.06 ± 0.1 in)	200 ± 3 mm (7.87 ± 0.1 in)
Dimension (B)	70 mm (2.76 in)	65 mm (2.56 in)

# SERVICE DATA AND SPECIFICATIONS (SDS)

## < SERVICE DATA AND SPECIFICATIONS (SDS)

	VQ35DE	
	LH	RH
Dimension (A)	220 ± 3 mm (8.66 ± 0.1 in)	205 ± 3 mm (8.07 ± 0.1 in)
Dimension (B)	50 mm (1.97 in)	50 mm (1.97 in)

### Boot Bands

INFOID:000000009464449

Unit: mm (in)

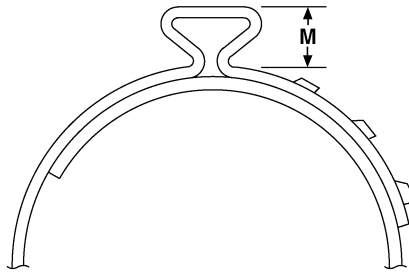

AWDIA0598ZZ

Dimension (M)	7.0 (0.28)
---------------	------------