

SECTION **PWO**
POWER OUTLET

A
B
C
D
E
F
G
H
I
J
K
L
N
O
P

CONTENTS

PRECAUTION	2	WIRING DIAGRAM	4
PRECAUTIONS	2	POWER SOCKET	4
Precaution for Supplemental Restraint System (SRS) "AIR BAG" and "SEAT BELT PRE-TEN- SIONER"	2	Wiring Diagram	4
PREPARATION	3	REMOVAL AND INSTALLATION	6
PREPARATION	3	POWER SOCKET	6
Special Service Tool	3	Removal and Installation	6

PWO

PRECAUTIONS

< PRECAUTION >

PRECAUTION

PRECAUTIONS

Precaution for Supplemental Restraint System (SRS) "AIR BAG" and "SEAT BELT PRE-TENSIONER"

INFOID:000000010480375

The Supplemental Restraint System such as "AIR BAG" and "SEAT BELT PRE-TENSIONER", used along with a front seat belt, helps to reduce the risk or severity of injury to the driver and front passenger for certain types of collision. Information necessary to service the system safely is included in the SR and SB section of this Service Manual.

WARNING:

- To avoid rendering the SRS inoperative, which could increase the risk of personal injury or death in the event of a collision which would result in air bag inflation, all maintenance must be performed by an authorized NISSAN/INFINITI dealer.
- Improper maintenance, including incorrect removal and installation of the SRS, can lead to personal injury caused by unintentional activation of the system. For removal of Spiral Cable and Air Bag Module, see the SR section.
- Do not use electrical test equipment on any circuit related to the SRS unless instructed to in this Service Manual. SRS wiring harnesses can be identified by yellow and/or orange harnesses or harness connectors.

PRECAUTIONS WHEN USING POWER TOOLS (AIR OR ELECTRIC) AND HAMMERS

WARNING:

- When working near the Airbag Diagnosis Sensor Unit or other Airbag System sensors with the Ignition ON or engine running, DO NOT use air or electric power tools or strike near the sensor(s) with a hammer. Heavy vibration could activate the sensor(s) and deploy the air bag(s), possibly causing serious injury.
- When using air or electric power tools or hammers, always switch the Ignition OFF, disconnect the battery and wait at least three minutes before performing any service.

PREPARATION

< PREPARATION >

PREPARATION

PREPARATION

Special Service Tool

INFOID:000000010480376

The actual shapes of the tools may differ from those illustrated here.

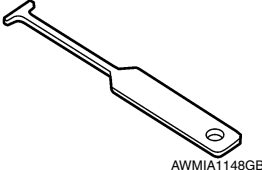
Tool number (TechMate No.) Tool name	Description
— (J-42059) Power socket removal tool  AWMIA1148GB	Removing power sockets

A

B

C

D

E

F

G

H

I

J

K

L

PWO

N

O

P

POWER SOCKET

< WIRING DIAGRAM >

WIRING DIAGRAM

POWER SOCKET

Wiring Diagram

INFOID:000000010480377

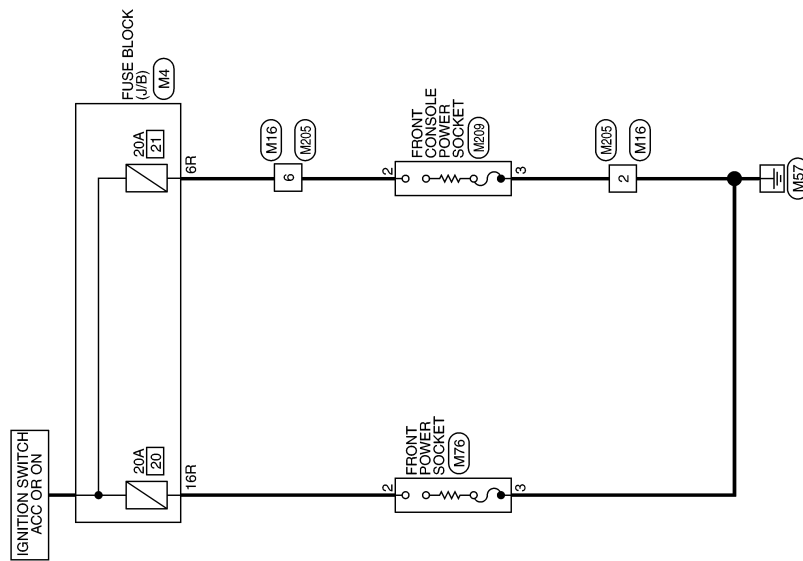

POWER SOCKET

ABMWA2168GB

POWER SOCKET

< WIRING DIAGRAM >

POWER SOCKET CONNECTORS

Connector No.	M4
Connector Name	FUSE BLOCK (J/B)
Connector Color	BROWN



Terminal No.	Color of Wire	Signal Name
6R	LG	-
16R	LG	-

Connector No.	M16
Connector Name	WIRE TO WIRE
Connector Color	WHITE

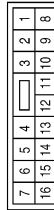

Terminal No.	Color of Wire	Signal Name
2	B	-
6	LG	-

Connector No.	M76
Connector Name	FRONT POWER SOCKET
Connector Color	GRAY



Terminal No.	Color of Wire	Signal Name
2	LG	-
3	GR	-

Connector No.	M205
Connector Name	WIRE TO WIRE
Connector Color	WHITE



Terminal No.	Color of Wire	Signal Name
2	B	-
6	LG	-

Connector No.	M209
Connector Name	FRONT CONSOLE POWER SOCKET
Connector Color	GRAY



Terminal No.	Color of Wire	Signal Name
2	LG	-
3	B	-

ABMIA5108GB

A
B
C
D
E
F
G
H
I
J
K
L
N
O
P

PWO

POWER SOCKET

< REMOVAL AND INSTALLATION >

REMOVAL AND INSTALLATION

POWER SOCKET

Removal and Installation

INFOID:000000010480378

FRONT POWER SOCKET OR FRONT CONSOLE POWER SOCKET

NOTE:

If unable to use the Tool because of the power socket location or access to the harness connector, then removal of interior components may be required. Refer to [IP-18, "Removal and Installation"](#) (Front Power Socket) or [IP-18, "Removal and Installation"](#) (Front Console Power Socket).

Removal

1. Remove the fuse for the power socket.
2. Insert one end of the Tool (A) into one of the square holes inside the power socket.

Tool number: — (J-42059)

3. Lift up the handle of the Tool until the other side snaps into the other square hole in the power socket.
4. Pull the power socket straight out with the Tool.

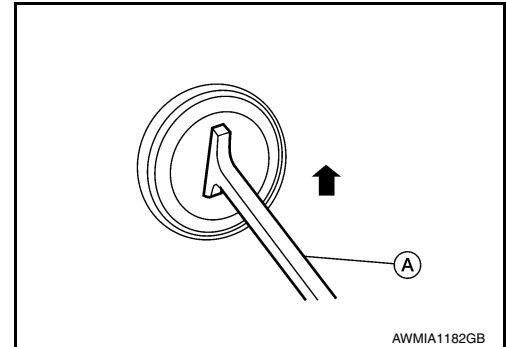

5. Disconnect harness connector from the power socket.
6. Remove ring from power socket finisher while pressing the pawls.

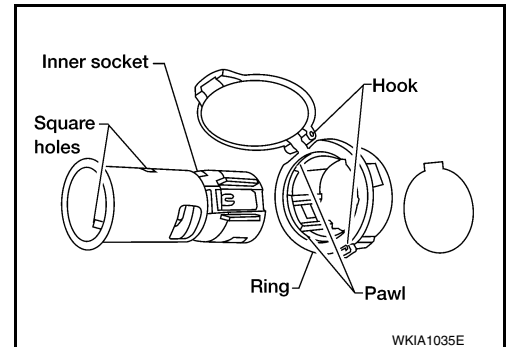

Installation

Installation is in the reverse order of removal.

NOTE:

Make sure to align the tab with the square notched area during installation.

