

SECTION PCS

POWER CONTROL SYSTEM

A
B
C
D
E
F
G
H
I
J
K
L
N
O
P

CONTENTS

IPDM E/R	Diagnosis Procedure	16
BASIC INSPECTION	POWER SUPPLY AND GROUND CIRCUIT	17
DIAGNOSIS AND REPAIR WORKFLOW	Diagnosis Procedure	17
Work Flow	ECU DIAGNOSIS INFORMATION	18
SYSTEM DESCRIPTION	IPDM E/R (INTELLIGENT POWER DISTRI- BUTION MODULE ENGINE ROOM)	18
RELAY CONTROL SYSTEM	Reference Value	18
System Diagram	Terminal Layout	19
System Description	Physical Values	20
Component Parts Location	Fail Safe	23
POWER CONTROL SYSTEM	DTC Index	24
System Diagram	WIRING DIAGRAM	25
System Description	IPDM E/R (INTELLIGENT POWER DISTRI- BUTION MODULE ENGINE ROOM)	25
SIGNAL BUFFER SYSTEM	Wiring Diagram	25
System Diagram	PRECAUTION	29
System Description	PRECAUTIONS	29
POWER CONSUMPTION CONTROL SYS- TEM	Precaution for Supplemental Restraint System (SRS) "AIR BAG" and "SEAT BELT PRE-TEN- SIONER"	29
System Diagram	Precaution Necessary for Steering Wheel Rota- tion After Battery Disconnect	29
System Description	UNIT REMOVAL AND INSTALLATION	31
Component Parts Location	IPDM E/R (INTELLIGENT POWER DISTRI- BUTION MODULE ENGINE ROOM)	31
DIAGNOSIS SYSTEM (IPDM E/R)	Removal and Installation of IPDM E/R	31
Diagnosis Description		
CONSULT Function (IPDM E/R)		
DTC/CIRCUIT DIAGNOSIS		
U1000 CAN COMM CIRCUIT		
Description		
DTC Logic		

PCS

DIAGNOSIS AND REPAIR WORKFLOW

< BASIC INSPECTION >

[IPDM E/R]

BASIC INSPECTION

DIAGNOSIS AND REPAIR WORKFLOW

Work Flow

INFOID:000000007316483

OVERALL SEQUENCE

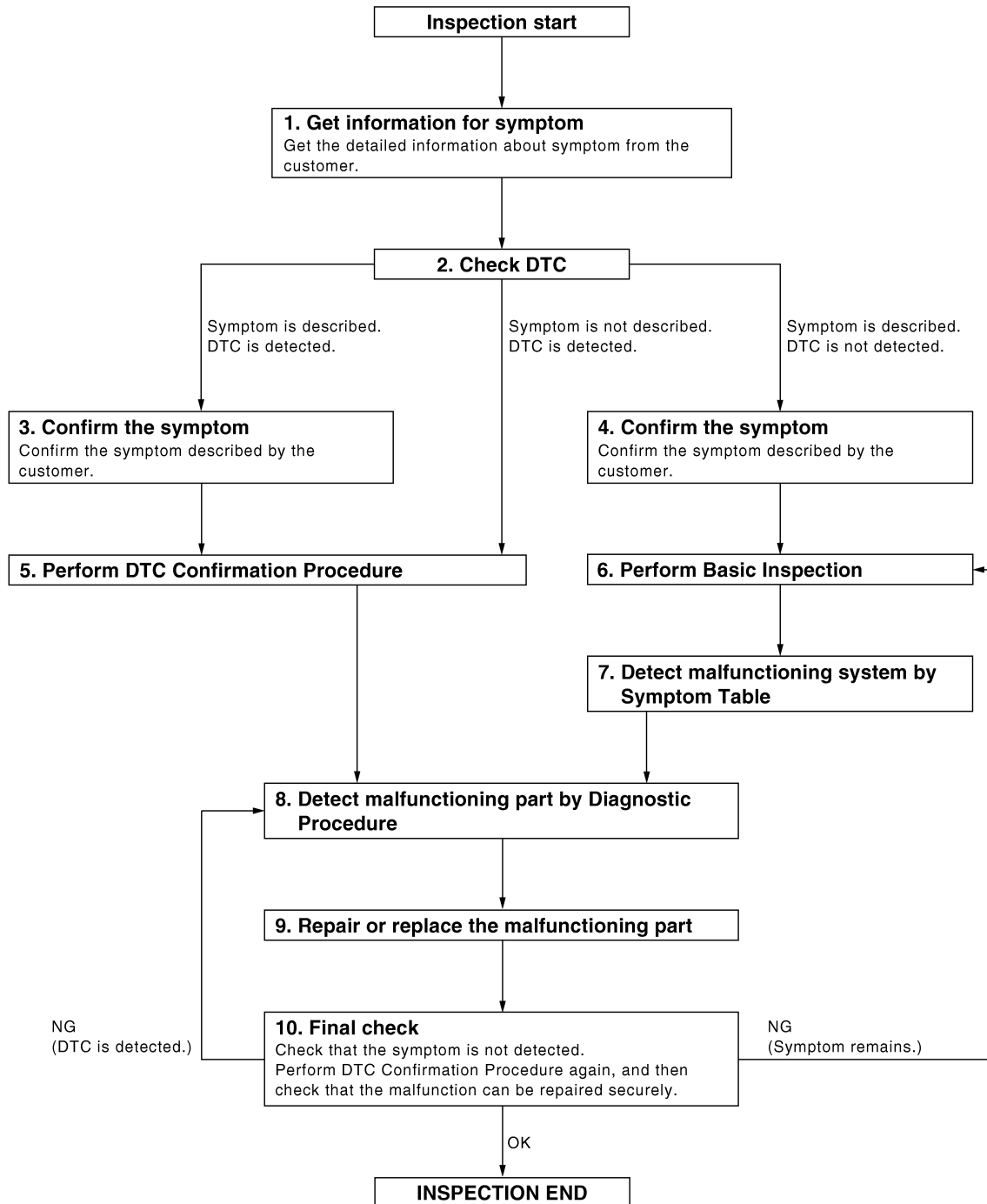

JMKIA0101GB

DETAILED FLOW

Revision: July 2012

PCS-2

2012 Armada

DIAGNOSIS AND REPAIR WORKFLOW

< BASIC INSPECTION >

[IPDM E/R]

1. GET INFORMATION FOR SYMPTOM

Get the detailed information from the customer about the symptom (the condition and the environment when the incident/malfunction occurred).

>> GO TO 2

2. CHECK DTC

1. Check DTC.
2. Perform the following procedure if DTC is displayed.
 - Record DTC and freeze frame data.
 - Erase DTC.
 - Study the relationship between the cause detected by DTC and the symptom described by the customer.
3. Check related service bulletins for information.

Is any symptom described and any DTC detected?

Symptom is described, DTC is displayed>>GO TO 3

Symptom is described, DTC is not displayed>>GO TO 4

Symptom is not described, DTC is displayed>>GO TO 5

3. CONFIRM THE SYMPTOM

Confirm the symptom described by the customer.

Connect CONSULT to the vehicle in "DATA MONITOR" mode and check real time diagnosis results.

Verify relationship between the symptom and the condition when the symptom is detected.

>> GO TO 5

4. CONFIRM THE SYMPTOM

Confirm the symptom described by the customer.

Connect CONSULT to the vehicle in "DATA MONITOR" mode and check real time diagnosis results.

Verify relationship between the symptom and the condition when the symptom is detected.

>> GO TO 6

5. PERFORM DTC CONFIRMATION PROCEDURE

Perform DTC Confirmation Procedure for the displayed DTC, and then check that DTC is detected again.

At this time, always connect CONSULT to the vehicle, and check diagnostic results in real time.

If two or more DTCs are detected, refer to [PCS-24, "DTC Index"](#) and determine trouble diagnosis order.

NOTE:

- Freeze frame data is useful if the DTC is not detected.
- Perform Component Function Check if DTC Confirmation Procedure is not included in Service Manual. This simplified check procedure is an effective alternative though DTC cannot be detected during this check. If the result of Component Function Check is NG, it is the same as the detection of DTC by DTC Confirmation Procedure.

Is DTC detected?

YES >> GO TO 8

NO >> Refer to [GI-38, "Intermittent Incident"](#).

6. PERFORM BASIC INSPECTION

Perform a basic inspection of the IPDM E/R.

Inspection End>>GO TO 7

7. DETECT MALFUNCTIONING SYSTEM BY SYMPTOM

Detect malfunctioning system according to the confirmed symptom in step 4, and determine the trouble diagnosis order based on possible causes and symptom.

>> GO TO 8

DIAGNOSIS AND REPAIR WORKFLOW

[IPDM E/R]

< BASIC INSPECTION >

8. DETECT MALFUNCTIONING PART BY DIAGNOSTIC PROCEDURE

Inspect according to Diagnostic Procedure of the system.

NOTE:

The Diagnostic Procedure described based on open circuit inspection. A short circuit inspection is also required for the circuit check in the Diagnostic Procedure.

Is malfunctioning part detected?

YES >> GO TO 9

NO >> Check voltage of related BCM terminals using CONSULT.

9. REPAIR OR REPLACE THE MALFUNCTIONING PART

1. Repair or replace the malfunctioning part.
2. Reconnect parts or connectors disconnected during Diagnostic Procedure again after repair and replacement.
3. Check DTC. If DTC is displayed, erase it.

>> GO TO 10

10. FINAL CHECK

When DTC was detected in step 2, perform DTC Confirmation Procedure or Component Function Check again, and then check that the malfunction have been fully repaired.

When symptom was described from the customer, refer to confirmed symptom in step 3 or 4 and check that the symptom is not detected.

Is the inspection result normal?

YES >> Inspection End.

NO (DTC is detected)>>GO TO 8

NO (Symptom remains)>>GO TO 6

RELAY CONTROL SYSTEM

< SYSTEM DESCRIPTION >

[IPDM E/R]

SYSTEM DESCRIPTION

RELAY CONTROL SYSTEM

System Diagram

INFOID:000000007316484

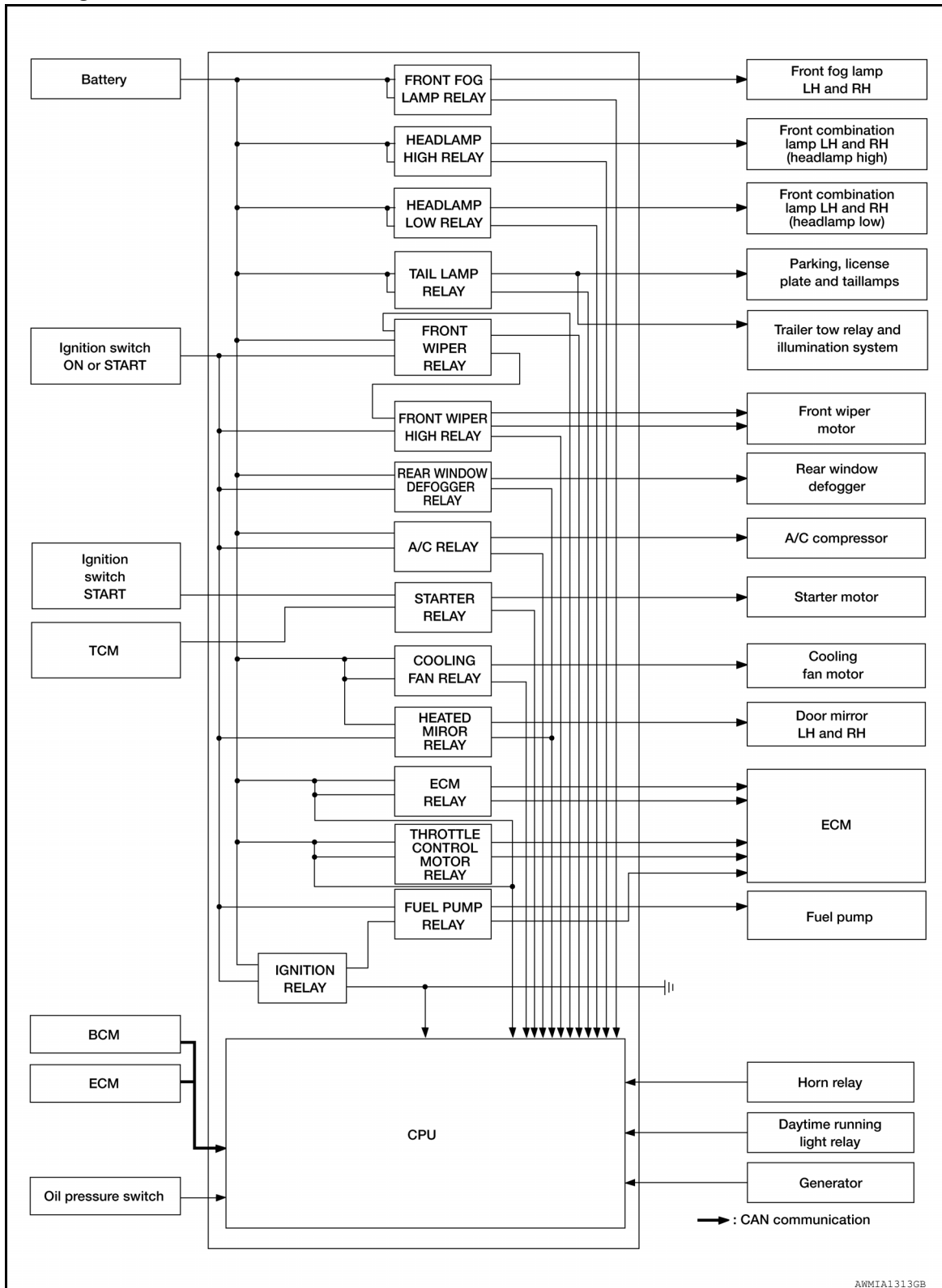

A
B
C
D
E
F
G
H
I
J
K
L
PCS
N
O
P

RELAY CONTROL SYSTEM

< SYSTEM DESCRIPTION >

[IPDM E/R]

System Description

INFOID:000000007316485

IPDM E/R activates the internal control circuit to perform the relay ON-OFF control according to the input signals from various sensors and the request signals received from control units via CAN communication.

CAUTION:

IPDM E/R integrated relays cannot be removed.

Control relay	Input/output	Transmit unit	Control part	Reference page
Front fog lamp relay	Front fog lamp request signal	BCM (CAN)	Front fog lamps	EXL-42
<ul style="list-style-type: none"> • Headlamp high relay • Headlamp low relay 	<ul style="list-style-type: none"> • High beam request signal LH • High beam request signal RH • Low beam request signal 	BCM (CAN)	<ul style="list-style-type: none"> • Headlamp high LH • Headlamp high RH • Headlamp low 	EXL-37 EXL-40
Tail lamp relay	Position light request signal	BCM (CAN)	<ul style="list-style-type: none"> • Parking lamps • License plate lamps • Tail lamps • Trailer tow relay • Illumination system 	EXL-128
<ul style="list-style-type: none"> • Front wiper relay • Front wiper high relay 	Front wiper request signal	BCM (CAN)	Front wiper motor	WW-4
Rear window defogger relay	Rear window defogger request signal	BCM (CAN)	Rear window defogger	DEF-4
A/C relay	A/C request signal	<ul style="list-style-type: none"> • BCM (CAN) • ECM (CAN) 	A/C compressor	HAC-13
Starter relay	Ignition switch START signal	TCM	Starter motor	STR-11
Cooling fan relay	Cooling fan request signal	ECM (CAN)	Cooling fan relay	EC-32
Heated mirror relay	Heated mirror request signal	BCM (CAN)	Door mirrors	DEF-4
ECM relay	ECM relay control signal	ECM (CAN)	ECM relay	EC-24
Throttle control motor relay	Throttle control motor control signal	ECM (CAN)	Throttle control motor relay	EC-24
Fuel pump relay	Fuel pump request signal	ECM (CAN)	Fuel pump	EC-24
Ignition relay	Ignition switch ON signal	Ignition switch	Ignition relay	EC-27

RELAY CONTROL SYSTEM

< SYSTEM DESCRIPTION >

[IPDM E/R]

Component Parts Location

INFOID:000000007316486

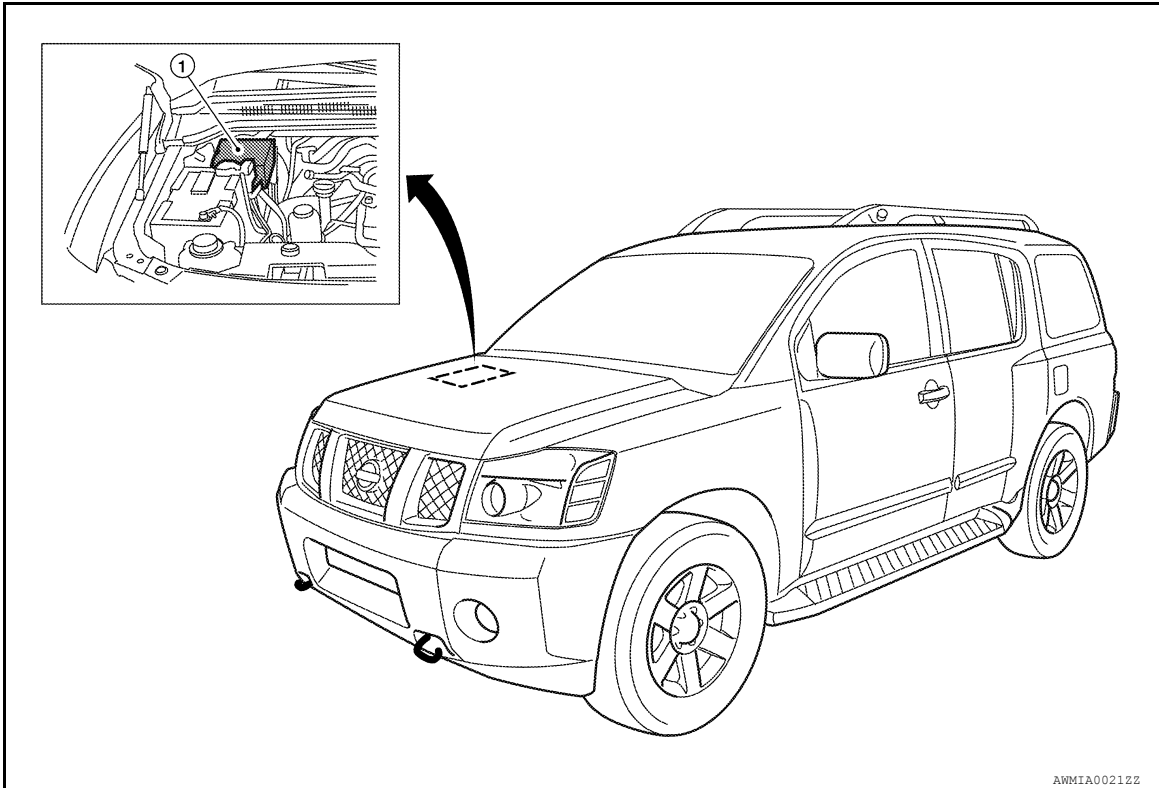

1. IPDM E/R E118, E119, E120, E121, E122, E123, E124

A
B
C
D
E
F
G
H
I
J
K
L

PCS

N
O
P

POWER CONTROL SYSTEM

System Diagram

INFOID:000000007316487

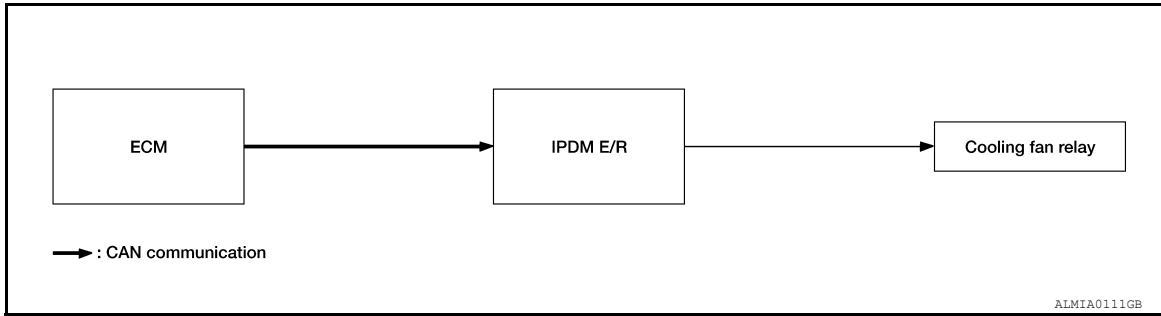

System Description

INFOID:000000007316488

COOLING FAN CONTROL

IPDM E/R controls the cooling fan according to the status of the cooling fan speed request signal received from ECM via CAN communication. Refer to [LAN-4, "System Description"](#).

SIGNAL BUFFER SYSTEM

< SYSTEM DESCRIPTION >

[IPDM E/R]

SIGNAL BUFFER SYSTEM

System Diagram

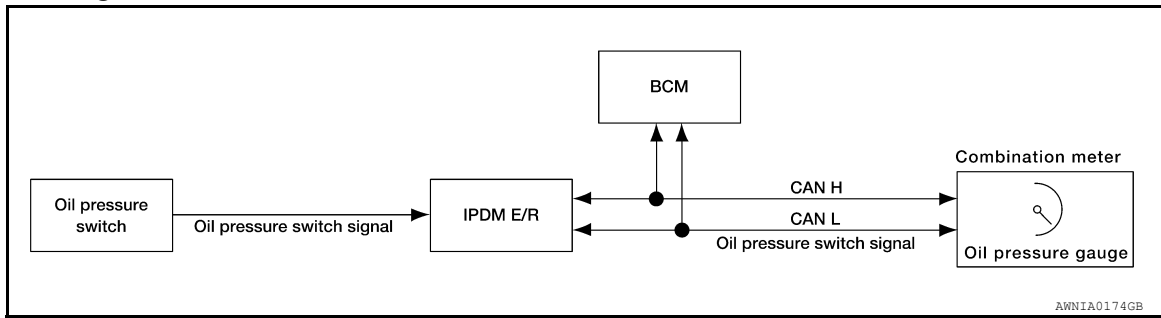

System Description

INFOID:000000007316490

IPDM E/R reads the status of the oil pressure switch and transmits the oil pressure switch signal to BCM via CAN communication. Refer to [LAN-4, "System Description"](#).

A
B
C
D
E
F
G
H
I
J
K
L

PCS

N
O
P

POWER CONSUMPTION CONTROL SYSTEM

< SYSTEM DESCRIPTION >

[IPDM E/R]

POWER CONSUMPTION CONTROL SYSTEM

System Diagram

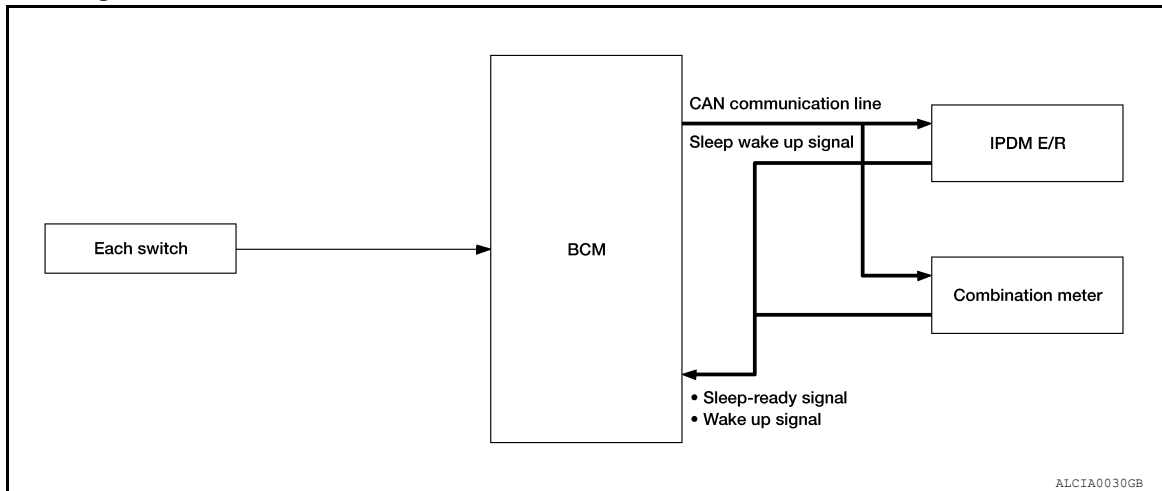

System Description

INFOID:000000007316492

OUTLINE

- IPDM E/R incorporates a power consumption control function that reduces the power consumption according to the vehicle status.
- IPDM E/R changes its status (control mode) with the sleep wake up signal received from BCM via CAN communication.

Normal mode (wake-up)

- CAN communication is normally performed with other control units.
- Individual unit control by IPDM E/R is normally performed.

Low power consumption mode (sleep)

- Low power consumption control is active.
- CAN transmission is stopped.

SLEEP MODE ACTIVATION

- IPDM E/R judges that the sleep-ready conditions are fulfilled when the ignition switch is OFF and none of the conditions below are present. Then it transmits a sleep-ready signal (ready) to BCM via CAN communication.
 - Front wiper fail-safe operation
 - Outputting signals to actuators
 - Switches or relays operating
 - Auto active test is starting
 - Emergency OFF
 - Output requests are being received from control units via CAN communication.
- IPDM E/R stops CAN communication and enters the low power consumption mode when it receives a sleep wake up signal (sleep) from BCM and the sleep-ready conditions are fulfilled.

WAKE-UP OPERATION

- IPDM E/R changes from the low power consumption mode to the normal mode when it receives a sleep wake-up signal (wake up) from BCM or any of the following conditions is fulfilled. In addition, it transmits a sleep-ready signal (not-ready) to BCM via CAN communication to report the CAN communication start.
 - Ignition switch ON
 - An output request is received from a control unit via CAN communication.

POWER CONSUMPTION CONTROL SYSTEM

< SYSTEM DESCRIPTION >

[IPDM E/R]

Component Parts Location

INFOID:000000007316493

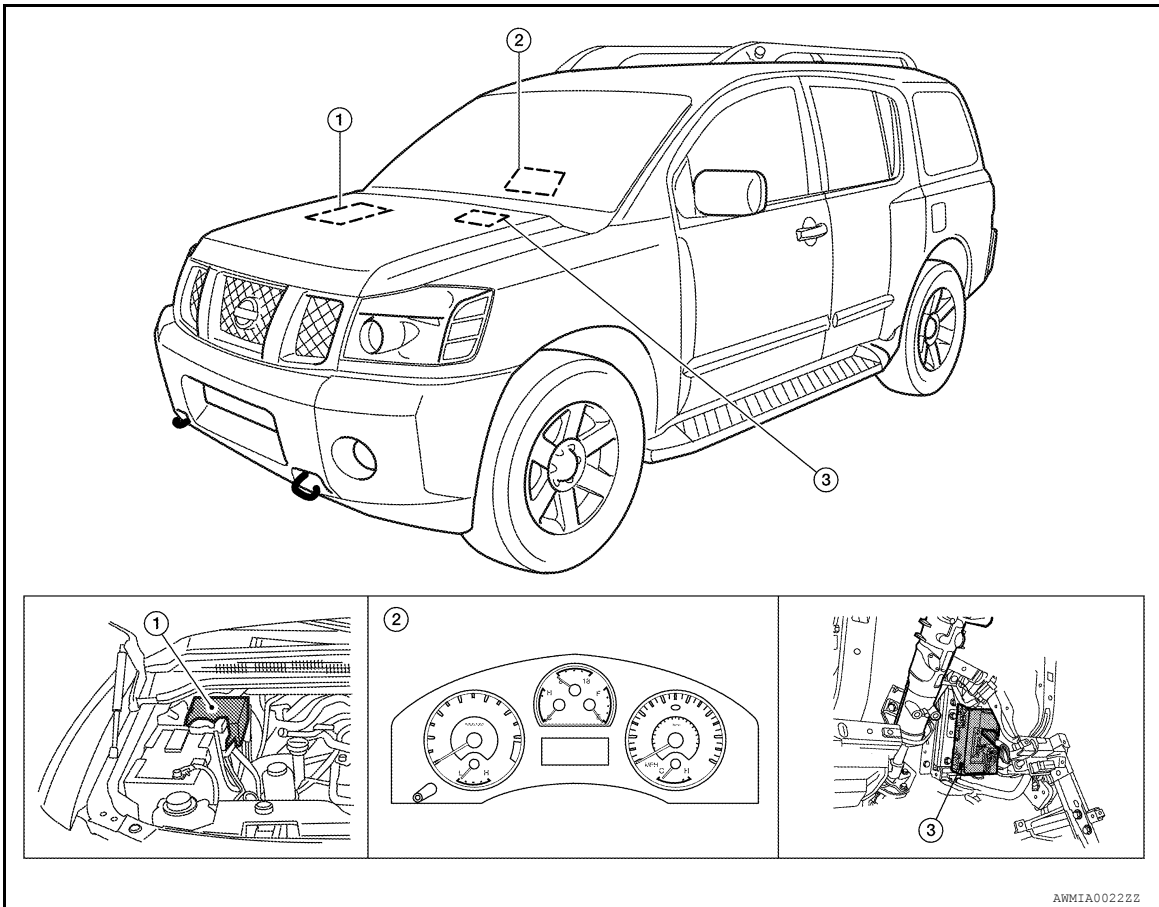

1. IPDM E/R

2. Combination meter

3. BCM (view with instrument panel removed)

A
B
C
D
E
F
G
H
I
J
K
L
N
O
P

PCS

DIAGNOSIS SYSTEM (IPDM E/R)

Diagnosis Description

INFOID:000000007316494

AUTO ACTIVE TEST

Description

In auto active test mode, the IPDM E/R sends a drive signal to the following systems to check their operation.

- Oil pressure low/coolant pressure high warning indicator
- Oil pressure gauge
- Rear window defogger
- Front wipers
- Tail, license and parking lamps
- Front fog lamps
- Headlamps (Hi, Lo)
- A/C compressor (magnetic clutch)
- Cooling fan

Operation Procedure

1. Close the hood and front door RH, and lift the wiper arms from the windshield (to prevent windshield damage due to wiper operation).
NOTE:
When auto active test is performed with hood opened, sprinkle water on windshield before hand.
2. Turn ignition switch OFF.
3. Turn the ignition switch ON and, within 20 seconds, press the front door switch LH 10 times. Then turn the ignition switch OFF.
4. Turn the ignition switch ON within 10 seconds. After that the horn sounds once and the auto active test starts.
5. After a series of the following operations is repeated 3 times, auto active test is completed.

NOTE:

When auto active test mode has to be cancelled halfway through test, turn ignition switch OFF.

CAUTION:

- If auto active test mode cannot be actuated, check door switch system. Refer to [DLK-74, "Description"](#) (with Intelligent Key system), [DLK-274, "Description"](#) (without Intelligent Key system).
- Do not start the engine.

Inspection in Auto Active Test Mode

When auto active test mode is actuated, the following 7 steps are repeated 3 times.

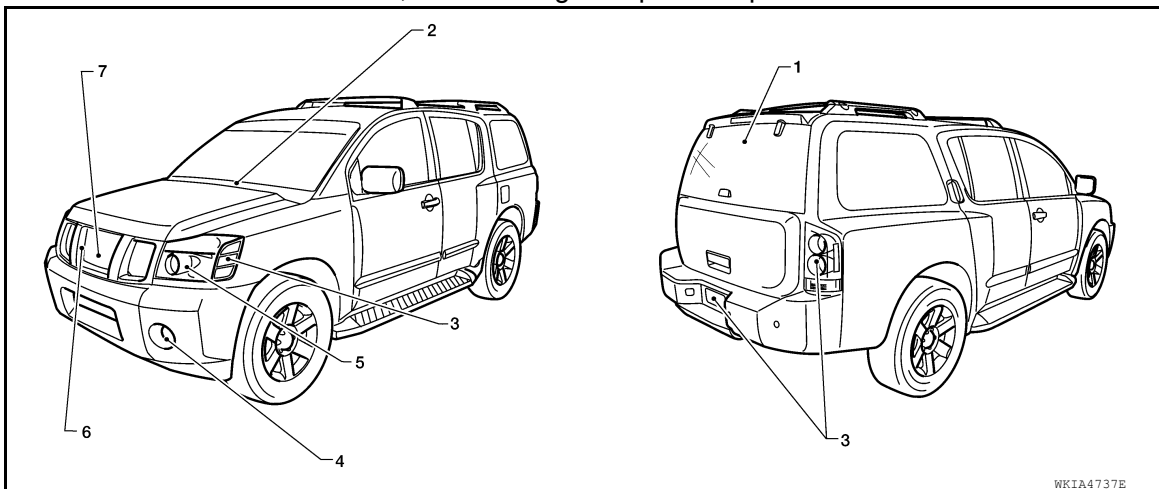

Operation sequence	Inspection Location	Operation
1	Rear window defogger	10 seconds
2	Front wipers	LO for 5 seconds → HI for 5 seconds

DIAGNOSIS SYSTEM (IPDM E/R)

< SYSTEM DESCRIPTION >

[IPDM E/R]

Operation sequence	Inspection Location	Operation
3	Tail, license and parking lamps	10 seconds
4	Front fog lamps	10 seconds
5	Headlamps	LO for 10 seconds → HI on-off for 5 seconds
6	A/C compressor	ON ⇔ OFF 5 times
7	Cooling fan	10 seconds

Concept of auto active test

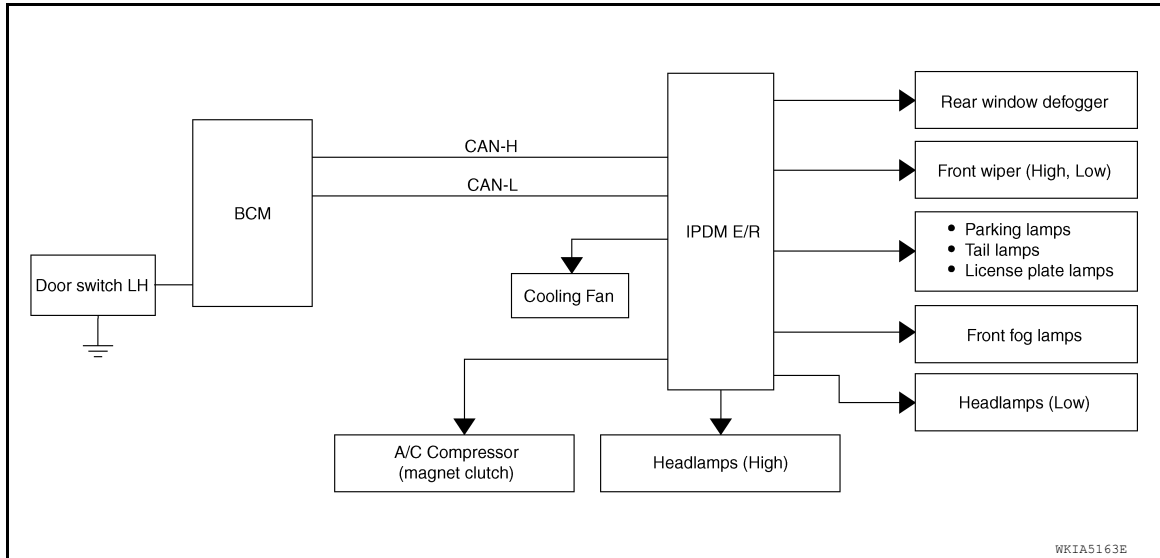

- IPDM E/R starts the auto active test with the door switch signals transmitted by BCM via CAN communication. Therefore, the CAN communication line between IPDM E/R and BCM is considered normal if the auto active test starts successfully.
- The auto active test facilitates troubleshooting if any systems controlled by IPDM E/R cannot be operated.

Diagnosis chart in auto active test mode

Symptom	Inspection contents	Possible cause
Oil pressure low/coolant temperature high warning indicator does not operate	Perform auto active test. Does the oil pressure low/coolant temperature high warning indicator operate?	YES • IPDM E/R signal input circuit • ECM signal input circuit • CAN communication signal between ECM and combination meter
		NO • CAN communication signal between IPDM E/R, BCM and combination meter
Oil pressure gauge does not operate	Perform auto active test. Does the oil pressure gauge operate?	YES IPDM E/R signal input circuit
		NO • CAN communication signal between IPDM E/R, BCM and combination meter
Rear window defogger does not operate	Perform auto active test. Does the rear window defogger operate?	YES BCM signal input circuit
		NO • Harness or connector between A/C and AV switch assembly and AV control unit • CAN communication signal between BCM and IPDM E/R

A
B
C
D
E
F
G
H
I
J
K
L
N
O
P

PCS

DIAGNOSIS SYSTEM (IPDM E/R)

< SYSTEM DESCRIPTION >

[IPDM E/R]

Symptom	Inspection contents	Possible cause	
Any of the following components do not operate <ul style="list-style-type: none"> • Front wipers • Tail lamps • License plate lamps • Parking lamps • Front fog lamps • Headlamps (Hi, Lo) 	Perform auto active test. Does the applicable system operate?	YES	BCM signal input system
		NO	<ul style="list-style-type: none"> • Lamp or front wiper motor malfunction • Lamp or front wiper motor ground circuit • Harness or connector between IPDM E/R and applicable system • IPDM E/R (integrated relay malfunction)
A/C compressor does not operate	Perform auto active test. Does the A/C compressor operate?	YES	<ul style="list-style-type: none"> • BCM signal input circuit • CAN communication signal between BCM and ECM • CAN communication signal between ECM and IPDM E/R
		NO	<ul style="list-style-type: none"> • Magnetic clutch malfunction • Harness or connector between IPDM E/R and magnetic clutch • IPDM E/R (integrated relay malfunction)
Cooling fan does not operate	Perform auto active test. Does the cooling fan operate?	YES	<ul style="list-style-type: none"> • ECM signal input circuit • CAN communication signal between ECM and IPDM E/R
		NO	<ul style="list-style-type: none"> • Cooling fan motor malfunction • Harness or connector between IPDM E/R and cooling fan • IPDM E/R (integrated relay malfunction)

CONSULT Function (IPDM E/R)

INFOID:000000007316495

APPLICATION ITEM

CONSULT performs the following functions via CAN communication with IPDM E/R.

Direct Diagnostic Mode	Description
Self Diagnostic Result	The IPDM E/R self diagnostic results are displayed.
Data Monitor	The IPDM E/R input/output data is displayed in real time.
Active Test	The IPDM E/R activates outputs to test components.
CAN Diag Support Mntr	The result of transmit/receive diagnosis of CAN communication is displayed.

SELF DIAGNOSTIC RESULT

Refer to [PCS-24, "DTC Index"](#).

DATA MONITOR

Monitor Item [Unit]	Main Signals	Description
MOTOR FAN REQ [1/2/3/4]	×	Indicates cooling fan speed signal received from ECM on CAN communication line
AC COMP REQ [On/Off]	×	Indicates A/C compressor request signal received from ECM on CAN communication line

DIAGNOSIS SYSTEM (IPDM E/R)

< SYSTEM DESCRIPTION >

[IPDM E/R]

Monitor Item [Unit]	Main Signals	Description
TAIL&CLR REQ [On/Off]	×	Indicates position light request signal received from BCM on CAN communication line
HL LO REQ [On/Off]	×	Indicates low beam request signal received from BCM on CAN communication line
HL HI REQ [On/Off]	×	Indicates high beam request signal received from BCM on CAN communication line
FR FOG REQ [On/Off]	×	Indicates front fog light request signal received from BCM on CAN communication line
FR WIP REQ [Stop/1LOW/Low/Hi]	×	Indicates front wiper request signal received from BCM on CAN communication line
WIP AUTO STOP [STOP P/ACT P]	×	Indicates condition of front wiper auto stop signal
WIP PROT [Off/BLOCK]	×	Indicates condition of front wiper fail-safe operation
ST RLY REQ [On/Off]		Indicates starter request signal received from ECM on CAN communication line
IGN RLY [On/Off]	×	Indicates condition of ignition relay
RR DEF REQ [On/Off]	×	Indicates rear defogger request signal received from AV control unit on CAN communication line
OIL P SW [Open/Close]		Indicates condition of oil pressure switch
DTRL REQ [Off]		Indicates daytime light request signal received from BCM on CAN communication line
THFT HRN REQ [On/Off]		Indicates theft warning horn request signal received from BCM on CAN communication line
HORN CHIRP [On/Off]		Indicates horn reminder signal received from BCM on CAN communication line

ACTIVE TEST

Test item	Description
REAR DEFOGGER	This test is able to check rear defogger operation [On/Off].
FRONT WIPER	This test is able to check wiper motor operation [Hi/Lo/Off].
MOTOR FAN	This test is able to check cooling fan operation [4/3/2/1].
EXTERNAL LAMPS	This test is able to check external lamp operation [Fog/Hi/Lo/TAIL/Off].
HORN	This test is able to check horn operation [On].

CAN DIAG SUPPORT MNTR

Refer to [LAN-49, "CAN Diagnostic Support Monitor"](#).

PCS

U1000 CAN COMM CIRCUIT

< DTC/CIRCUIT DIAGNOSIS >

[IPDM E/R]

DTC/CIRCUIT DIAGNOSIS

U1000 CAN COMM CIRCUIT

Description

INFOID:000000007316496

Refer to [LAN-4, "System Description"](#).

DTC Logic

INFOID:000000007316497

DTC DETECTION LOGIC

DTC	CONSULT display description	DTC Detection Condition	Possible cause
U1000	CAN COMM CIRCUIT	When IPDM E/R cannot communicate CAN communication signal continuously for 2 seconds or more	In CAN communication system, any item (or items) of the following listed below is malfunctioning. <ul style="list-style-type: none">• Receiving (TCM)• Receiving (ECM)• Receiving (BCM)• Receiving (Combination meter)

DTC CONFIRMATION PROCEDURE

Diagnosis Procedure

INFOID:000000007316498

1. PERFORM SELF DIAGNOSTIC

1. Turn ignition switch ON and wait for 2 seconds or more.
2. Check "SELF-DIAG RESULTS" of IPDM E/R.

Is "CAN COMM CIRCUIT" displayed?

- YES >> Refer to [LAN-14, "Trouble Diagnosis Flow Chart"](#).
NO >> Refer to [GI-38, "Intermittent Incident"](#).

POWER SUPPLY AND GROUND CIRCUIT

< DTC/CIRCUIT DIAGNOSIS >

[IPDM E/R]

POWER SUPPLY AND GROUND CIRCUIT

Diagnosis Procedure

INFOID:000000007316499

Regarding Wiring Diagram information, refer to [PCS-25. "Wiring Diagram"](#).

1. CHECK FUSES AND FUSIBLE LINK

Check that the following IPDM E/R fuses or fusible link are not blown.

Terminal No.	Signal name	Fuses and fusible link No.
1	Battery	A, D
2	Battery	C
12	Ignition switch ON or START	59

Is the fuse blown?

- YES >> Replace the blown fuse or fusible link after repairing the affected circuit.
 NO >> GO TO 2

2. CHECK BATTERY POWER SUPPLY CIRCUIT

- Turn ignition switch OFF.
- Disconnect IPDM E/R.
- Check voltage between IPDM E/R harness connectors and ground.

Terminals		(-)	Ignition switch position		
(+)	Connector		Terminal	OFF	ON
E118 (A)	1	Ground	Battery voltage	Battery voltage	Battery voltage
	2		Battery voltage	Battery voltage	Battery voltage
E119 (B)	12		0V	Battery voltage	Battery voltage

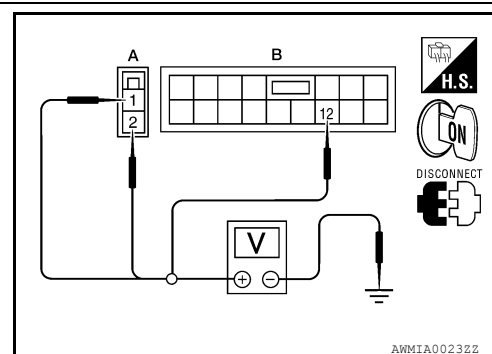

Is the measurement value normal?

- YES >> GO TO 3
 NO >> Repair or replace harness.

3. CHECK GROUND CIRCUIT

- Turn ignition switch OFF.
- Check continuity between IPDM E/R harness connectors and ground.

IPDM E/R		Ground	Continuity
Connector	Terminal		
E122 (A)	38	Ground	Yes
E124 (B)	59		

Does continuity exist?

- YES >> Inspection End.
 NO >> Repair or replace harness.

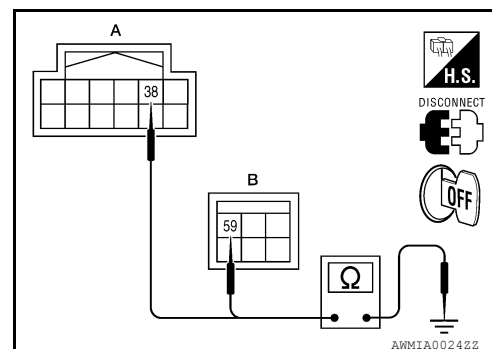

IPDM E/R (INTELLIGENT POWER DISTRIBUTION MODULE ENGINE ROOM)

< ECU DIAGNOSIS INFORMATION >

[IPDM E/R]

ECU DIAGNOSIS INFORMATION

IPDM E/R (INTELLIGENT POWER DISTRIBUTION MODULE ENGINE ROOM)

Reference Value

INFOID:000000007316500

VALUES ON THE DIAGNOSIS TOOL

Monitor Item	Condition		Value/Status
MOTOR FAN REQ	Engine idle speed	Changes depending on engine coolant temperature, air conditioner operation status, vehicle speed, etc.	1, 2, 3, 4
A/C COMP REQ	A/C switch OFF		Off
	A/C switch ON		On
TAIL&CLR REQ	Lighting switch OFF		Off
	Lighting switch 1ST, 2ND, HI or AUTO (Light is illuminated)		On
HL LO REQ	Lighting switch OFF		Off
	Lighting switch 2ND HI or AUTO (Light is illuminated)		On
HL HI REQ	Lighting switch OFF		Off
	Lighting switch HI		On
FR FOG REQ	Lighting switch 2ND or AUTO (Light is illuminated)	Front fog lamp switch OFF	Off
		<ul style="list-style-type: none"> • Front fog lamp switch ON • Daytime light activated (Canada only) 	On
FR WIP REQ	Ignition switch ON	Front wiper switch OFF	Stop
		Front wiper switch INT	1LOW
		Front wiper switch LO	Low
		Front wiper switch HI	Hi
WIP AUTO STOP	Ignition switch ON	Front wiper stop position	STOP P
		Any position other than front wiper stop position	ACT P
WIP PROT	Ignition switch ON	Front wiper operates normally	Off
		Front wiper stops at fail-safe operation	BLOCK
ST RLY REQ	Ignition switch OFF or ACC		Off
	Ignition switch START		On
IGN RLY	Ignition switch OFF or ACC		Off
	Ignition switch ON		On
RR DEF REQ	Rear defogger switch OFF		Off
	Rear defogger switch ON		On
OIL P SW	Ignition switch OFF, ACC or engine running		Open
	Ignition switch ON		Close
DTRL REQ	Not operated		Off
	Daytime Running Lights ON		On
THFT HRN REQ	Not operated		Off
	<ul style="list-style-type: none"> • Panic alarm is activated • Horn is activated with VEHICLE SECURITY (THEFT WARNING) SYSTEM 		On

IPDM E/R (INTELLIGENT POWER DISTRIBUTION MODULE ENGINE ROOM)

< ECU DIAGNOSIS INFORMATION >

[IPDM E/R]

Monitor Item	Condition	Value/Status
HORN CHIRP	Not operated	Off
	Door locking with keyfob or Intelligent Key (if equipped) (horn chirp mode)	On

Terminal Layout

INFOID:000000007316501

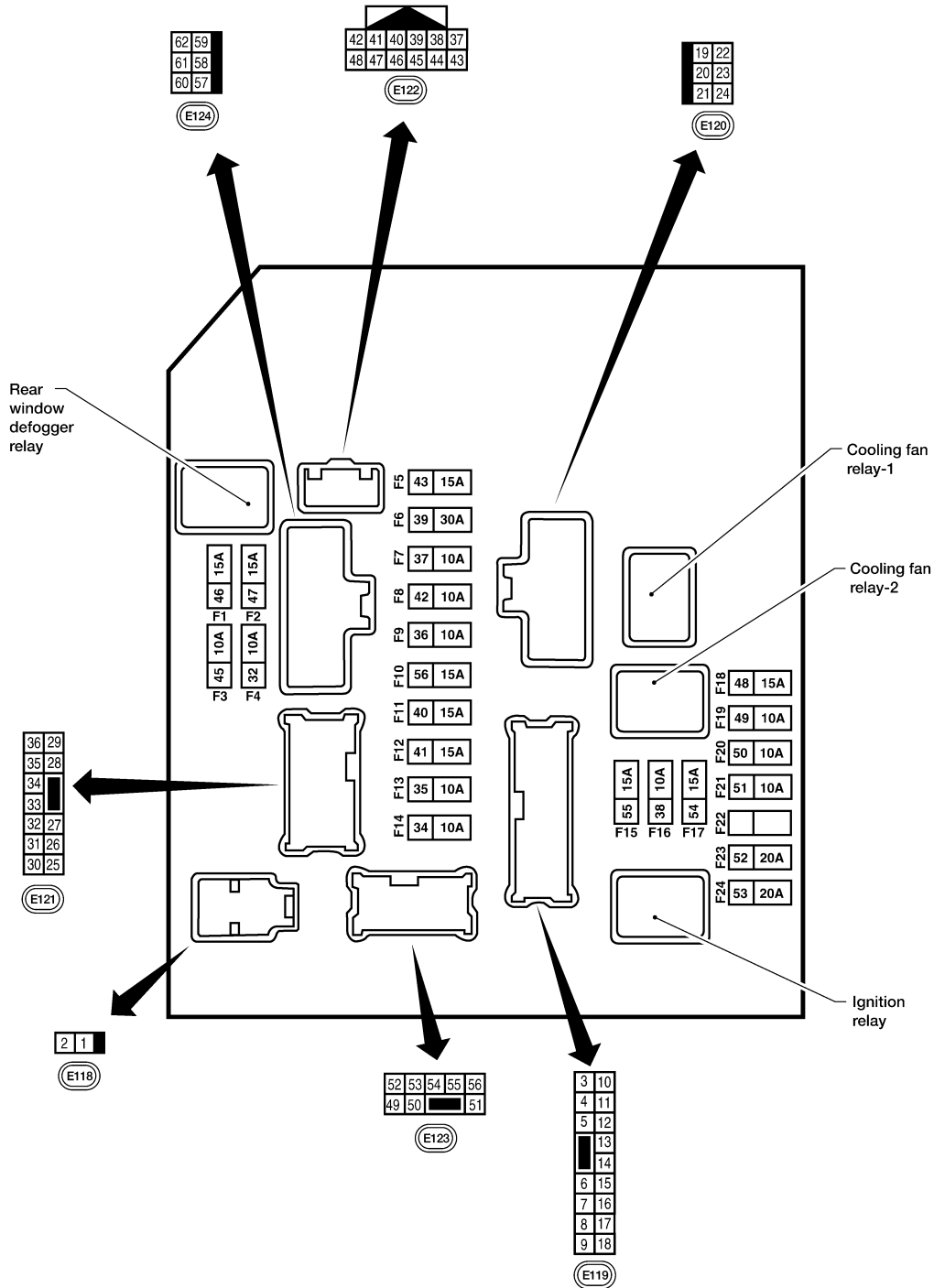

NOTE:

Numbers preceded by an "F" represent the fuse numbers imprinted on the IPDM E/R. The other numbers represent the fuse numbers as they appear in the wiring diagrams.

AAMIA0386GB

A
B
C
D
E
F
G
H
I
J
K
L
PCS
N
O
P

IPDM E/R (INTELLIGENT POWER DISTRIBUTION MODULE ENGINE ROOM)

< ECU DIAGNOSIS INFORMATION >

[IPDM E/R]

Physical Values

INFOID:000000007316502

PHYSICAL VALUES

Terminal	Wire color	Signal name	Signal input/output	Measuring condition		Reference value (Approx.)
				Ignition switch	Operation or condition	
1	B/Y	Battery power supply	Input	OFF	—	Battery voltage
2	R	Battery power supply	Input	OFF	—	Battery voltage
3	BR	ECM relay	Output	—	Ignition switch ON or START	Battery voltage
					Ignition switch OFF or ACC	0V
4	W/L	ECM relay	Output	—	Ignition switch ON or START	Battery voltage
					Ignition switch OFF or ACC	0V
6	L	Throttle control motor relay	Output	—	Ignition switch ON or START	Battery voltage
					Ignition switch OFF or ACC	0V
7	W/B	ECM relay control	Input	—	Ignition switch ON or START	0V
					Ignition switch OFF or ACC	Battery voltage
8	R/B	Fuse 54	Output	—	Ignition switch ON or START	Battery voltage
					Ignition switch OFF or ACC	0V
10	G	Fuse 45 (Canada only)	Output	ON	Daytime light system active	0V
					Daytime light system inactive	Battery voltage
11	Y/B	A/C compressor	Output	ON or START	A/C switch ON or defrost A/C switch	Battery voltage
					A/C switch OFF or defrost A/C switch	0V
12	L/W	Ignition switch supplied power	Input	—	OFF or ACC	0V
					ON or START	Battery voltage
13	B/Y	Fuel pump relay	Output	—	Ignition switch ON or START	Battery voltage
					Ignition switch OFF or ACC	0V
14	Y/R	Fuse 49	Output	—	Ignition switch ON or START	Battery voltage
					Ignition switch OFF or ACC	0V
15	LG/B	Fuse 50	Output	—	Ignition switch ON or START	Battery voltage
					Ignition switch OFF or ACC	0V
16	G	Fuse 51	Output	—	Ignition switch ON or START	Battery voltage
					Ignition switch OFF or ACC	0V
17	W	Fuse 55	Output	—	Ignition switch ON or START	Battery voltage
					Ignition switch OFF or ACC	0V
19	W/R	Starter motor	Output	START	—	Battery voltage
21	BR	Ignition switch supplied power	Input	—	OFF or ACC	0V
					START	Battery voltage
22	G	Battery power supply	Output	OFF	—	Battery voltage
23	GR/W	Door mirror defogger output signal	Output	—	When rear defogger switch is ON	Battery voltage
					When rear defogger switch is OFF	0V

IPDM E/R (INTELLIGENT POWER DISTRIBUTION MODULE ENGINE ROOM)

< ECU DIAGNOSIS INFORMATION >

[IPDM E/R]

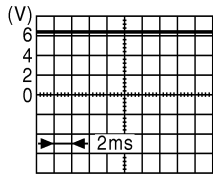
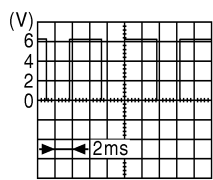
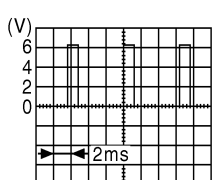
Terminal	Wire color	Signal name	Signal input/output	Measuring condition		Reference value (Approx.)
				Ignition switch	Operation or condition	
24	L	Cooling fan relay	Output	—	Conditions correct for cooling fan operation	Battery voltage
					Conditions not correct for cooling fan operation	0V
27	W/B	Fuse 38 (With trailer tow)	Output	—	Ignition switch ON or START	Battery voltage
					Ignition switch OFF or ACC	0V
30	W	Fuse 53	Output	—	Ignition switch ON or START	Battery voltage
					Ignition switch OFF or ACC	0V
32	L	Wiper low speed signal	Output	ON or START	Wiper switch OFF	Battery voltage
					LO or INT	0V
35	L/B	Wiper high speed signal	Output	ON or START	Wiper switch OFF, LO, INT	Battery voltage
					HI	0V
37	Y	Power generation command signal	Output	—	Ignition switch ON	 <p style="text-align: center;">6.3 V</p>
					40% is set on "Active test," "ALTERNATOR DUTY" of "ENGINE"	 <p style="text-align: center;">3.8 V</p>
					40% is set on "Active test," "ALTERNATOR DUTY" of "ENGINE"	 <p style="text-align: center;">1.4 V</p>
38	B	Ground	Input	—	—	0V
39	L	CAN-H	—	ON	—	—
40	P	CAN-L	—	ON	—	—
42	GR	Oil pressure switch	Input	—	Engine running	Battery voltage
					Engine stopped	0V
43	L/Y	Wiper auto stop signal	Input	ON or START	Wiper switch OFF, LO, INT	Battery voltage
44	BR	Daytime light relay control (Canada only)	Input	ON	Daytime light system active	0V
					Daytime light system inactive	Battery voltage

A
B
C
D
E
F
G
H
I
J
K
L
N
O
P

PCS

IPDM E/R (INTELLIGENT POWER DISTRIBUTION MODULE ENGINE ROOM)

< ECU DIAGNOSIS INFORMATION >

[IPDM E/R]

Terminal	Wire color	Signal name	Signal input/output	Measuring condition		Reference value (Approx.)
				Ignition switch	Operation or condition	
45	G/W	Horn relay control	Input	ON	When door locks are operated using keyfob or Intelligent Key (if equipped) (OFF → ON)*	Battery voltage → 0V
46	GR	Fuel pump relay control	Input	—	Ignition switch ON or START	0V
					Ignition switch OFF or ACC	Battery voltage
47	O	Throttle control motor relay control	Input	—	Ignition switch ON or START	0V
					Ignition switch OFF or ACC	Battery voltage
48	B/R	Starter relay (inhibit switch)	Input	ON or START	Selector lever in "P" or "N"	0V
					Selector lever any other position	Battery voltage
49	R/L	Trailer tow relay (With trailer tow) Illumination (Without trailer tow)	Output	ON	Lighting switch must be in the 1st position	OFF 0V
						ON Battery voltage
50	W/R	Front fog lamp (LH)	Output	ON or START	Lighting switch must be in the 2nd position (LOW beam is ON) and the front fog lamp switch	OFF 0V
						ON Battery voltage
51	W/R	Front fog lamp (RH)	Output	ON or START	Lighting switch must be in the 2nd position (LOW beam is ON) and the front fog lamp switch	OFF 0V
						ON Battery voltage
52	L	LH low beam head-lamp	Output	—	Lighting switch in 2nd position	Battery voltage
54	R/Y	RH low beam head-lamp	Output	—	Lighting switch in 2nd position	Battery voltage
55	G	LH high beam head-lamp	Output	—	Lighting switch in 2nd position and placed in HIGH or PASS position	Battery voltage
56	Y (With DTRL)	RH high beam head-lamp	Output	—	Lighting switch in 2nd position and placed in HIGH or PASS position	Battery voltage
56	L/W (Without DTRL)	RH high beam head-lamp	Output	—	Lighting switch in 2nd position and placed in HIGH or PASS position	Battery voltage
57	R/L	Parking, license, and tail lamp	Output	ON	Lighting switch 1st position	OFF 0V
						ON Battery voltage
59	B	Ground	Input	—	—	0V
60	B/W	Rear window defogger relay	Output	ON or START	Rear defogger switch ON	Battery voltage
					Rear defogger switch OFF	0V
61	BR	Fuse 32 (With trailer tow)	Output	OFF	—	Battery voltage

IPDM E/R (INTELLIGENT POWER DISTRIBUTION MODULE ENGINE ROOM)

< ECU DIAGNOSIS INFORMATION >

[IPDM E/R]

*: When horn reminder is ON

Fail Safe

INFOID:000000007316503

CAN COMMUNICATION CONTROL

When CAN communication with ECM and BCM is impossible, IPDM E/R performs fail-safe control. After CAN communication recovers normally, it also returns to normal control.

If No CAN Communication Is Available With ECM

Control part	Fail-safe in operation
Cooling fan	<ul style="list-style-type: none">• Turns ON the cooling fan relay when the ignition switch is turned ON• Turns OFF the cooling fan relay when the ignition switch is turned OFF

If No CAN Communication Is Available With BCM

Control part	Fail-safe in operation
Headlamp	<ul style="list-style-type: none">• Turns ON the headlamp low relay when the ignition switch is turned ON• Turns OFF the headlamp low relay when the ignition switch is turned OFF• Headlamp high relay OFF
<ul style="list-style-type: none">• Parking lamps• License plate lamps• Tail lamps	<ul style="list-style-type: none">• Turns ON the tail lamp relay when the ignition switch is turned ON• Turns OFF the tail lamp relay when the ignition switch is turned OFF
Front wiper	<ul style="list-style-type: none">• The status just before activation of fail-safe control is maintained until the ignition switch is turned OFF while the front wiper is operating at LO or HI speed.• The wiper is operated at LO speed until the ignition switch is turned OFF if the fail-safe control is activated while the front wiper is set in the INT mode and the front wiper motor is operating.
Rear window defogger	Rear window defogger relay OFF
A/C compressor	A/C relay OFF
Front fog lamps	Front fog lamp relay OFF

IGNITION RELAY MALFUNCTION DETECTION FUNCTION

- IPDM E/R monitors the voltage at the contact circuit and excitation coil circuit of the ignition relay inside it.
- IPDM E/R judges the ignition relay error if the voltage differs between the contact circuit and the excitation coil circuit.
- If the ignition relay cannot turn OFF due to contact seizure, it activates the tail lamp relay for 10 minutes to alert the user to the ignition relay malfunction when the ignition switch is turned OFF.

Ignition switch	Ignition relay	Tail lamp relay
ON	ON	—
OFF	OFF	—

NOTE:

The tail lamp turns OFF when the ignition switch is turned ON.

FRONT WIPER CONTROL

IPDM E/R detects front wiper stop position by a front wiper auto stop signal.

When a front wiper auto stop signal is in the conditions listed below, IPDM E/R stops power supply to wiper after repeating a front wiper 10 second activation and 20 second stop five times.

Ignition switch	Front wiper switch	Auto stop signal
ON	OFF	Front wiper stop position signal cannot be input 10 seconds.
	ON	The signal does not change for 10 seconds.

NOTE:

This operation status can be confirmed on the IPDM E/R "DATA MONITOR" that displays "Block" for the item "WIP PROT" while the wiper is stopped.

A
B
C
D
E
F
G
H
I
J
K
L

PCS

N
O
P

IPDM E/R (INTELLIGENT POWER DISTRIBUTION MODULE ENGINE ROOM)

< ECU DIAGNOSIS INFORMATION >

[IPDM E/R]

STARTER MOTOR PROTECTION FUNCTION

IPDM E/R turns OFF the starter control relay to protect the starter motor when the starter control relay remains active for 90 seconds.

DTC Index

INFOID:000000007316504

CONSULT display	Fail-safe	TIME ^{NOTE}		Refer to
No DTC is detected. further testing may be required.	—	—	—	—
U1000: CAN COMM CIRCUIT	×	CRNT	1 – 39	PCS-16

NOTE:

The details of TIME display are as follows.

- CRNT: The malfunctions that are detected now
- 1 - 39: The number is indicated when it is normal at present and a malfunction was detected in the past. It increases like 0 → 1 → 2 ... 38 → 39 after returning to the normal condition whenever IGN OFF → ON. It is fixed to 39 until the self-diagnosis results are erased if it is over 39. It returns to 0 when a malfunction is detected again in the process.

IPDM E/R (INTELLIGENT POWER DISTRIBUTION MODULE ENGINE ROOM)

< WIRING DIAGRAM >

[IPDM E/R]

WIRING DIAGRAM

IPDM E/R (INTELLIGENT POWER DISTRIBUTION MODULE ENGINE ROOM)

Wiring Diagram

INFOID:000000007316505

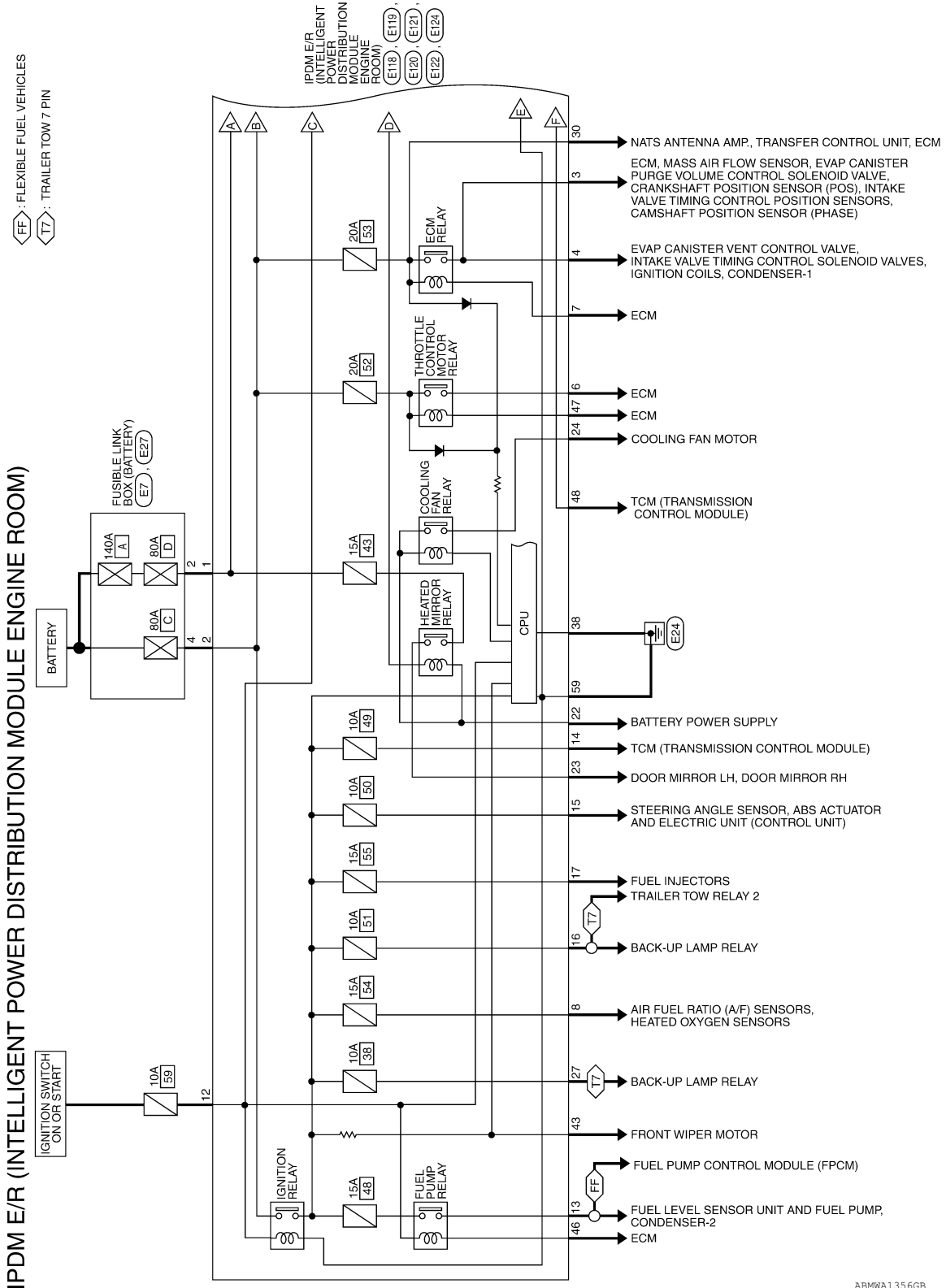

ABMWA1356GB

A
B
C
D
E
F
G
H
I
J
K
L
N
O
P

PCS

IPDM E/R (INTELLIGENT POWER DISTRIBUTION MODULE ENGINE ROOM)

< WIRING DIAGRAM >

[IPDM E/R]

FL : WITH FRONT FOG LAMPS
N : FOR CANADA
TZ : TRAILER TOW 7 PIN

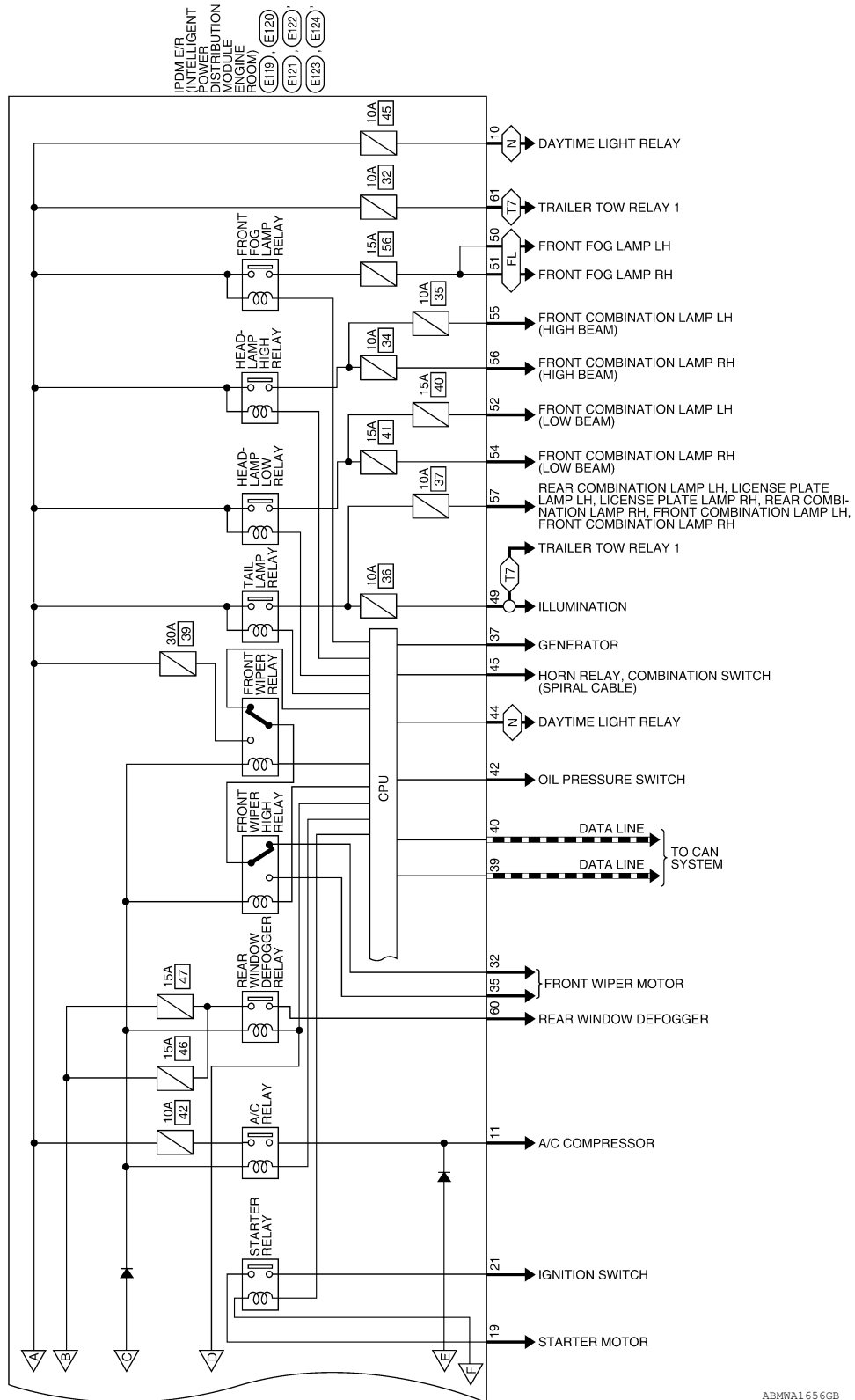

ABMWA1656GB

IPDM E/R (INTELLIGENT POWER DISTRIBUTION MODULE ENGINE ROOM)

< WIRING DIAGRAM >

[IPDM E/R]

IPDM E/R (INTELLIGENT POWER DISTRIBUTION MODULE ENGINE ROOM) CONNECTORS

Connector No.	E7
Connector Name	FUSIBLE LINK BOX (BATTERY)
Connector Color	GRAY

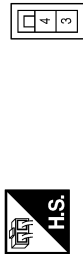

Terminal No.	Color of Wire	Signal Name
4	R	-

Connector No.	E27
Connector Name	FUSIBLE LINK BOX (BATTERY)
Connector Color	BROWN



Terminal No.	Color of Wire	Signal Name
2	B/Y	-

Connector No.	E118
Connector Name	IPDM E/R (INTELLIGENT POWER DISTRIBUTION MODULE ENGINE ROOM)
Connector Color	BLACK



Terminal No.	Color of Wire	Signal Name
1	B/Y	F/L USM
2	R	F/L MAIN

Connector No.	E119
Connector Name	IPDM E/R (INTELLIGENT POWER DISTRIBUTION MODULE ENGINE ROOM)
Connector Color	WHITE

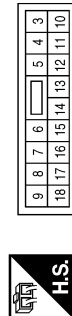

Terminal No.	Color of Wire	Signal Name
3	BR	IGN COIL
4	W/L	ECM
5	-	-
6	L	ETC
7	W/B	ECM RLY CONT
8	R/B	O2 SENSOR
9	-	-
10	G	DTRL RLY SUPPLY
11	Y/B	A/C COMPRESSOR
12	L/W	IGN SW (IG)
13	B/Y	FUEL PUMP
14	Y/R	AT CU IGN SUPPLY
15	LG/B	ABS IGN SUPPLY
16	G	REVERSE LAMP
17	W	INJECTOR
18	-	-

Connector No.	E120
Connector Name	IPDM E/R (INTELLIGENT POWER DISTRIBUTION MODULE ENGINE ROOM)
Connector Color	WHITE



Terminal No.	Color of Wire	Signal Name
19	W/R	STARTER MTR
20	-	-
21	BR	IGN SW (ST)
22	G	F/L MOTOR FAN
23	GR/W	HEATED MIRROR
24	L	MOTOR FAN 2

Connector No.	E121
Connector Name	IPDM E/R (INTELLIGENT POWER DISTRIBUTION MODULE ENGINE ROOM)
Connector Color	BROWN



Terminal No.	Color of Wire	Signal Name
25	-	-
26	-	-
27	W/B	TTOW REV LAMP
28	-	-
29	-	-
30	W	ECM BAT
31	-	-
32	L	FR WIPER LO
33	-	-
34	-	-
35	L/B	FR WIPER HI
36	-	-

ABMIA2479GB

A
B
C
D
E
F
G
H
I
J
K
L
M
N
O
P

PCS

IPDM E/R (INTELLIGENT POWER DISTRIBUTION MODULE ENGINE ROOM)

< WIRING DIAGRAM >

[IPDM E/R]

Connector No.	E123
Connector Name	IPDM E/R (INTELLIGENT POWER DISTRIBUTION MODULE ENGINE ROOM)
Connector Color	BROWN



51	50	49
56	55	54
53	52	51

Terminal No.	Color of Wire	Signal Name
49	R/L	ILLUMINATION
50	W/R	FR FOG LAMP LH
51	W/R	FR FOG LAMP RH
52	L	H/LAMP LO LH
53	-	-
54	R/Y	H/LAMP LO RH
55	G	H/LAMP HI LH
56	L/W	H/LAMP HI RH (WITHOUT DAYTIME LIGHT)
56	Y	H/LAMP HI RH (WITH DAYTIME LIGHT)

Terminal No.	Color of Wire	Signal Name
37	Y	ALT-C CONT
38	B	GND (SIGNAL)
39	L	CAN-H
40	P	CAN-L
41	-	-
42	GR	OIL PRESSURE SW
43	L/Y	AUTO STOP SW
44	BR	DTRL RLY CONT
45	G/W	ANT THEFT HORN
46	GR	FUEL PUMP RLY CONT
47	O	ETC RLY CONT
48	B/R	RANGE SW

Connector No.	E122
Connector Name	IPDM E/R (INTELLIGENT POWER DISTRIBUTION MODULE ENGINE ROOM)
Connector Color	WHITE



42	41	40	39	38	37
48	47	46	45	44	43

Terminal No.	Color of Wire	Signal Name
61	BR	TRAIL RLY SUPPLY
62	-	-

Connector No.	E124
Connector Name	IPDM E/R (INTELLIGENT POWER DISTRIBUTION MODULE ENGINE ROOM)
Connector Color	BLACK



59	58	57
62	61	60

Terminal No.	Color of Wire	Signal Name
57	R/L	TAIL LAMP
58	-	-
59	B	GND (POWER)
60	B/W	RR DEF

ABMIA3331GB

< PRECAUTION >

PRECAUTION

PRECAUTIONS

Precaution for Supplemental Restraint System (SRS) "AIR BAG" and "SEAT BELT PRE-TENSIONER"

INFOID:000000007316506

The Supplemental Restraint System such as "AIR BAG" and "SEAT BELT PRE-TENSIONER", used along with a front seat belt, helps to reduce the risk or severity of injury to the driver and front passenger for certain types of collision. This system includes seat belt switch inputs and dual stage front air bag modules. The SRS system uses the seat belt switches to determine the front air bag deployment, and may only deploy one front air bag, depending on the severity of a collision and whether the front occupants are belted or unbelted. Information necessary to service the system safely is included in the SR and SB section of this Service Manual.

WARNING:

- To avoid rendering the SRS inoperative, which could increase the risk of personal injury or death in the event of a collision which would result in air bag inflation, all maintenance must be performed by an authorized NISSAN/INFINITI dealer.
- Improper maintenance, including incorrect removal and installation of the SRS, can lead to personal injury caused by unintentional activation of the system. For removal of Spiral Cable and Air Bag Module, see the SR section.
- Do not use electrical test equipment on any circuit related to the SRS unless instructed to in this Service Manual. SRS wiring harnesses can be identified by yellow and/or orange harnesses or harness connectors.

PRECAUTIONS WHEN USING POWER TOOLS (AIR OR ELECTRIC) AND HAMMERS

WARNING:

- When working near the Airbag Diagnosis Sensor Unit or other Airbag System sensors with the Ignition ON or engine running, DO NOT use air or electric power tools or strike near the sensor(s) with a hammer. Heavy vibration could activate the sensor(s) and deploy the air bag(s), possibly causing serious injury.
- When using air or electric power tools or hammers, always switch the Ignition OFF, disconnect the battery, and wait at least 3 minutes before performing any service.

Precaution Necessary for Steering Wheel Rotation After Battery Disconnect

INFOID:000000007316507

NOTE:

- This Procedure is applied only to models with Intelligent Key system and NATS (NISSAN ANTI-THEFT SYSTEM).
- Remove and install all control units after disconnecting both battery cables with the ignition knob in the "LOCK" position.
- Always use CONSULT to perform self-diagnosis as a part of each function inspection after finishing work. If DTC is detected, perform trouble diagnosis according to self-diagnostic results.

For models equipped with the Intelligent Key system and NATS, an electrically controlled steering lock mechanism is adopted on the key cylinder.

For this reason, if the battery is disconnected or if the battery is discharged, the steering wheel will lock and steering wheel rotation will become impossible.

If steering wheel rotation is required when battery power is interrupted, follow the procedure below before starting the repair operation.

OPERATION PROCEDURE

1. Connect both battery cables.

NOTE:

Supply power using jumper cables if battery is discharged.

2. Use the Intelligent Key or mechanical key to turn the ignition switch to the "ACC" position. At this time, the steering lock will be released.
3. Disconnect both battery cables. The steering lock will remain released and the steering wheel can be rotated.
4. Perform the necessary repair operation.

A
B
C
D
E
F
G
H
I
J
K
L
PCS
N
O
P

PRECAUTIONS

< PRECAUTION >

[IPDM E/R]

-
5. When the repair work is completed, return the ignition switch to the "LOCK" position before connecting the battery cables. (At this time, the steering lock mechanism will engage.)
 6. Perform a self-diagnosis check of all control units using CONSULT.

UNIT REMOVAL AND INSTALLATION

IPDM E/R (INTELLIGENT POWER DISTRIBUTION MODULE ENGINE ROOM)

Removal and Installation of IPDM E/R

INFOID:000000007316508

CAUTION:

IPDM E/R integrated relays are not serviceable parts, and must not be removed from the unit.

REMOVAL

1. Disconnect negative battery cable.
2. Remove IPDM E/R upper cover.

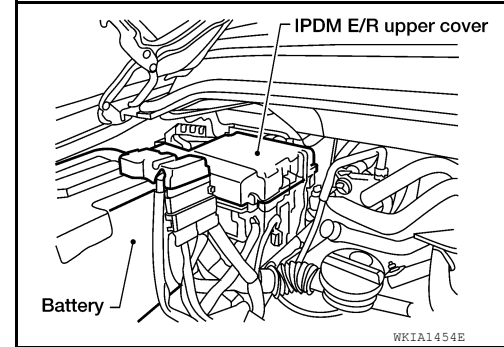

3. Release 2 clips and pull IPDM E/R up from case.
4. Disconnect IPDM E/R connectors and remove the IPDM E/R.

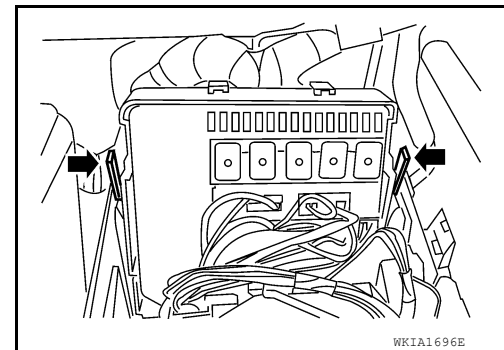

INSTALLATION

Installation is in the reverse order of removal.

A
B
C
D
E
F
G
H
I
J
K
L

PCS