

SECTION **INT**  
INTERIOR

A  
B  
C  
D  
E  
F  
G  
H  
I  
INT  
K  
L  
M  
N  
O  
P

CONTENTS

<b>SYMPTOM DIAGNOSIS</b> .....	2	<b>CLIP LIST</b> .....	11
<b>SQUEAK AND RATTLE TROUBLE DIAG- NOSES</b> .....	2	Descriptions for Clips .....	11
Work Flow .....	2	<b>REMOVAL AND INSTALLATION</b> .....	15
Generic Squeak and Rattle Troubleshooting .....	4	<b>DOOR FINISHER</b> .....	15
Diagnostic Worksheet .....	6	Removal and Installation .....	15
<b>PRECAUTION</b> .....	8	<b>BODY SIDE TRIM</b> .....	18
<b>PRECAUTIONS</b> .....	8	Removal and Installation .....	18
Precaution for Supplemental Restraint System (SRS) "AIR BAG" and "SEAT BELT PRE-TEN- SIONER" .....	8	<b>FLOOR TRIM</b> .....	20
Precaution Necessary for Steering Wheel Rota- tion After Battery Disconnect .....	8	Removal and Installation .....	20
Precaution for Work .....	9	<b>HEADLINING</b> .....	21
<b>PREPARATION</b> .....	10	Removal and Installation .....	21
<b>PREPARATION</b> .....	10	<b>LUGGAGE FLOOR TRIM</b> .....	24
Special Service Tool .....	10	Removal and Installation .....	24
Commercial Service Tool .....	10	<b>BACK DOOR TRIM</b> .....	26
		Removal and Installation .....	26

# SQUEAK AND RATTLE TROUBLE DIAGNOSES

< SYMPTOM DIAGNOSIS >

## SYMPTOM DIAGNOSIS

### SQUEAK AND RATTLE TROUBLE DIAGNOSES

#### Work Flow

INFOID:000000009823445

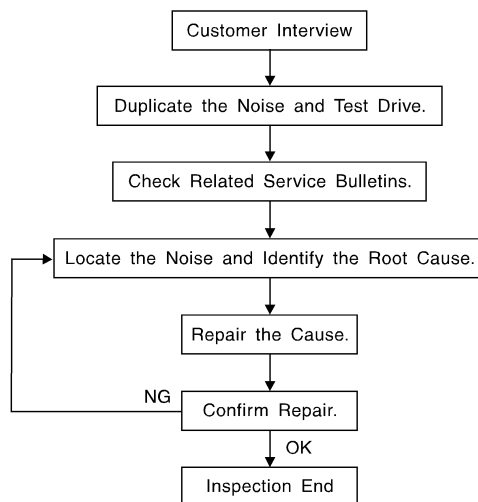

SBT842

#### CUSTOMER INTERVIEW

Interview the customer if possible, to determine the conditions that exist when the noise occurs. Use the Diagnostic Worksheet during the interview to document the facts and conditions when the noise occurs and any customer's comments; refer to [INT-6, "Diagnostic Worksheet"](#). This information is necessary to duplicate the conditions that exist when the noise occurs.

- The customer may not be able to provide a detailed description or the location of the noise. Attempt to obtain all the facts and conditions that exist when the noise occurs (or does not occur).
- If there is more than one noise in the vehicle, be sure to diagnose and repair the noise that the customer is concerned about. This can be accomplished by test driving the vehicle with the customer.
- After identifying the type of noise, isolate the noise in terms of its characteristics. The noise characteristics are provided so the customer, service adviser and technician are all speaking the same language when defining the noise.
- Squeak —(Like tennis shoes on a clean floor)  
Squeak characteristics include the light contact/fast movement/brought on by road conditions/hard surfaces = higher pitch noise/softer surfaces = lower pitch noises/edge to surface = chirping.
- Creak—(Like walking on an old wooden floor)  
Creak characteristics include firm contact/slow movement/twisting with a rotational movement/pitch dependent on materials/often brought on by activity.
- Rattle—(Like shaking a baby rattle)  
Rattle characteristics include the fast repeated contact/vibration or similar movement/loose parts/missing clip or fastener/incorrect clearance.
- Knock —(Like a knock on a door)  
Knock characteristics include hollow sounding/sometimes repeating/often brought on by driver action.
- Tick—(Like a clock second hand)  
Tick characteristics include gentle contacting of light materials/loose components/can be caused by driver action or road conditions.
- Thump—(Heavy, muffled knock noise)  
Thump characteristics include softer knock/dead sound often brought on by activity.
- Buzz—(Like a bumble bee)  
Buzz characteristics include high frequency rattle/firm contact.
- Often the degree of acceptable noise level will vary depending upon the person. A noise that you may judge as acceptable may be very irritating to the customer.
- Weather conditions, especially humidity and temperature, may have a great effect on noise level.

#### DUPLICATE THE NOISE AND TEST DRIVE

# SQUEAK AND RATTLE TROUBLE DIAGNOSES

## < SYMPTOM DIAGNOSIS >

If possible, drive the vehicle with the customer until the noise is duplicated. Note any additional information on the Diagnostic Worksheet regarding the conditions or location of the noise. This information can be used to duplicate the same conditions when you confirm the repair.

If the noise can be duplicated easily during the test drive, to help identify the source of the noise, try to duplicate the noise with the vehicle stopped by doing one or all of the following:

- 1) Close a door.
  - 2) Tap or push/pull around the area where the noise appears to be coming from.
  - 3) Rev the engine.
  - 4) Use a floor jack to recreate vehicle "twist".
  - 5) At idle, apply engine load (electrical load, half-clutch on M/T model, drive position on CVT and A/T models).
  - 6) Raise the vehicle on a hoist and hit a tire with a rubber hammer.
- Drive the vehicle and attempt to duplicate the conditions the customer states exist when the noise occurs.
  - If it is difficult to duplicate the noise, drive the vehicle slowly on an undulating or rough road to stress the vehicle body.

## CHECK RELATED SERVICE BULLETINS

After verifying the customer concern or symptom, check ASIST for Technical Service Bulletins (TSBs) related to that concern or symptom.

If a TSB relates to the symptom, follow the procedure to repair the noise.

## LOCATE THE NOISE AND IDENTIFY THE ROOT CAUSE

1. Narrow down the noise to a general area. To help pinpoint the source of the noise, use a listening tool (Chassis Ear: J-39570, Engine Ear: J-39565 and mechanic's stethoscope).
2. Narrow down the noise to a more specific area and identify the cause of the noise by:
  - removing the components in the area that you suspect the noise is coming from.  
Do not use too much force when removing clips and fasteners, otherwise clips and fasteners can be broken or lost during the repair, resulting in the creation of new noise.
  - tapping or pushing/pulling the component that you suspect is causing the noise.  
Do not tap or push/pull the component with excessive force, otherwise the noise will be eliminated only temporarily.
  - feeling for a vibration with your hand by touching the component(s) that you suspect is (are) causing the noise.
  - placing a piece of paper between components that you suspect are causing the noise.
  - looking for loose components and contact marks.Refer to [INT-4, "Generic Squeak and Rattle Troubleshooting"](#).

## REPAIR THE CAUSE

- If the cause is a loose component, tighten the component securely.
- If the cause is insufficient clearance between components:
  - separate components by repositioning or loosening and retightening the component, if possible.
  - insulate components with a suitable insulator such as urethane pads, foam blocks, felt cloth tape or urethane tape. A NISSAN Squeak and Rattle Kit (J-43980) is available through your authorized NISSAN Parts Department.

### **CAUTION:**

**Do not use excessive force as many components are constructed of plastic and may be damaged.**

**Always check with the Parts Department for the latest parts information.**

**The following materials are contained in the NISSAN Squeak and Rattle Kit (J-43980). Each item can be ordered separately as needed.**

### **URETHANE PADS [1.5 mm (0.059 in) thick]**

**Insulates connectors, harness, etc.**

**76268-9E005: 100×135 mm (3.94×5.31 in)/76884-71L01: 60×85 mm (2.36×3.35 in)/76884-71L02: 15×25 mm (0.59×0.98 in)**

### **INSULATOR (Foam blocks)**

**Insulates components from contact. Can be used to fill space behind a panel.**

**73982-9E000: 45 mm (1.77 in) thick, 50×50 mm (1.97×1.97 in)/73982-50Y00: 10 mm (0.39 in) thick, 50×50 mm (1.97×1.97 in)**

### **INSULATOR (Light foam block)**

**80845-71L00: 30 mm (1.18 in) thick, 30×50 mm (1.18×1.97 in)**

### **FELT CLOTH TAPE**

**Used to insulate where movement does not occur. Ideal for instrument panel applications.**

**68370-4B000: 15×25 mm (0.59×0.98 in) pad/68239-13E00: 5 mm (0.20 in) wide tape roll. The following materials not found in the kit can also be used to repair squeaks and rattles.**

# SQUEAK AND RATTLE TROUBLE DIAGNOSES

## < SYMPTOM DIAGNOSIS >

---

### UHMW (TEFLON) TAPE

Insulates where slight movement is present. Ideal for instrument panel applications.

### SILICONE GREASE

Used instead of UHMW tape that will be visible or not fit.

Note: Will only last a few months.

### SILICONE SPRAY

Use when grease cannot be applied.

### DUCT TAPE

Use to eliminate movement.

### CONFIRM THE REPAIR

Confirm that the cause of a noise is repaired by test driving the vehicle. Operate the vehicle under the same conditions as when the noise originally occurred. Refer to the notes on the Diagnostic Worksheet.

## Generic Squeak and Rattle Troubleshooting

INFOID:000000009823446

Refer to Table of Contents for specific component removal and installation information.

### INSTRUMENT PANEL

Most incidents are caused by contact and movement between:

1. Cluster lid A and the instrument panel
2. Acrylic lens and combination meter housing
3. Instrument panel to front pillar finisher
4. Instrument panel to windshield
5. Instrument panel pins
6. Wiring harnesses behind the combination meter
7. A/C defroster duct and duct joint

These incidents can usually be located by tapping or moving the components to duplicate the noise or by pressing on the components while driving to stop the noise. Most of these incidents can be repaired by applying felt cloth tape or silicone spray (in hard to reach areas). Urethane pads can be used to insulate wiring harness.

### CAUTION:

**Do not use silicone spray to isolate a squeak or rattle. If you saturate the area with silicone, you will not be able to recheck the repair.**

### CENTER CONSOLE

Components to pay attention to include:

1. Shift selector assembly cover to finisher
2. A/C control unit and cluster lid C
3. Wiring harnesses behind audio and A/C control unit

The instrument panel repair and isolation procedures also apply to the center console.

### DOORS

Pay attention to the:

1. Finisher and inner panel making a slapping noise
2. Inside handle escutcheon to door finisher
3. Wiring harnesses tapping
4. Door striker out of alignment causing a popping noise on starts and stops

Tapping or moving the components or pressing on them while driving to duplicate the conditions can isolate many of these incidents. You can usually insulate the areas with felt cloth tape or insulator foam blocks from the NISSAN Squeak and Rattle Kit (J-43980) to repair the noise.

### TRUNK

Trunk noises are often caused by a loose jack or loose items put into the trunk by the owner.

In addition look for:

1. Trunk lid bumpers out of adjustment
2. Trunk lid striker out of adjustment
3. The trunk lid torsion bars knocking together

# SQUEAK AND RATTLE TROUBLE DIAGNOSES

## < SYMPTOM DIAGNOSIS >

---

### 4. A loose license plate or bracket

Most of these incidents can be repaired by adjusting, securing or insulating the item(s) or component(s) causing the noise.

A

### SUNROOF/HEADLINING

Noises in the sunroof/headlining area can often be traced to one of the following:

B

1. Sunroof lid, rail, linkage or seals making a rattle or light knocking noise
2. Sun visor shaft shaking in the holder
3. Front or rear windshield touching headlining and squeaking

C

Again, pressing on the components to stop the noise while duplicating the conditions can isolate most of these incidents. Repairs usually consist of insulating with felt cloth tape.

D

### OVERHEAD CONSOLE (FRONT AND REAR)

Overhead console noises are often caused by the console panel clips not being engaged correctly. Most of these incidents are repaired by pushing up on the console at the clip locations until the clips engage.

E

In addition look for:

1. Loose harness or harness connectors.
2. Front console map/reading lamp lens loose.
3. Loose screws at console attachment points.

F

### SEATS

When isolating seat noise it's important to note the position the seat is in and the load placed on the seat when the noise is present. These conditions should be duplicated when verifying and isolating the cause of the noise.

G

Cause of seat noise include:

H

1. Headrest rods and holder
2. A squeak between the seat pad cushion and frame
3. The rear seatback lock and bracket

I

These noises can be isolated by moving or pressing on the suspected components while duplicating the conditions under which the noise occurs. Most of these incidents can be repaired by repositioning the component or applying urethane tape to the contact area.

INT

### UNDERHOOD

Some interior noise may be caused by components under the hood or on the engine wall. The noise is then transmitted into the passenger compartment.

K

Causes of transmitted underhood noise include:

1. Any component installed to the engine wall
2. Components that pass through the engine wall
3. Engine wall mounts and connectors
4. Loose radiator installation pins
5. Hood bumpers out of adjustment
6. Hood striker out of adjustment

L

M

These noises can be difficult to isolate since they cannot be reached from the interior of the vehicle. The best method is to secure, move or insulate one component at a time and test drive the vehicle. Also, engine rpm or load can be changed to isolate the noise. Repairs can usually be made by moving, adjusting, securing, or insulating the component causing the noise.

N

O

P

# SQUEAK AND RATTLE TROUBLE DIAGNOSES

< SYMPTOM DIAGNOSIS >

## Diagnostic Worksheet

INFOID:00000009823447

Dear Customer:

We are concerned about your satisfaction with your vehicle. Repairing a squeak or rattle sometimes can be very difficult. To help us fix your vehicle right the first time, please take a moment to note the area of the vehicle where the squeak or rattle occurs and under what conditions. You may be asked to take a test drive with a service advisor or technician to ensure we confirm the noise you are hearing.

### SQUEAK & RATTLE DIAGNOSTIC WORKSHEET

#### I. WHERE DOES THE NOISE COME FROM? (circle the area of the vehicle)

The illustrations are for reference only, and may not reflect the actual configuration of your vehicle.

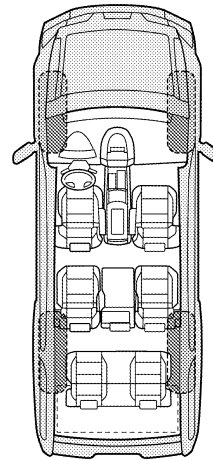
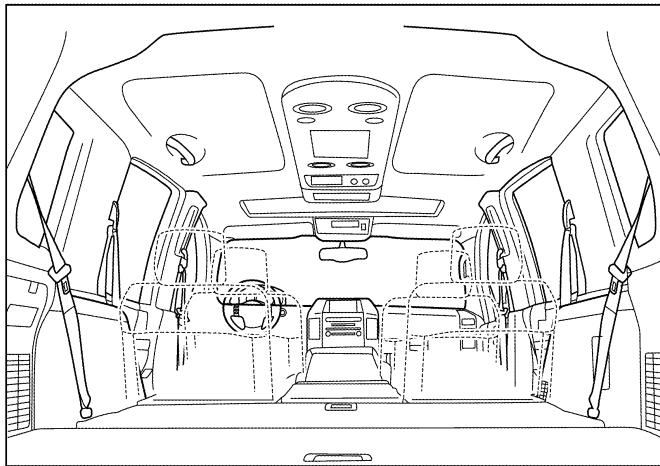
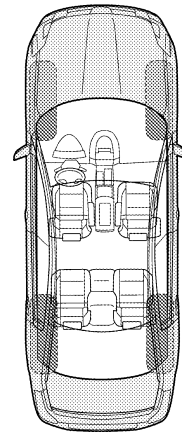
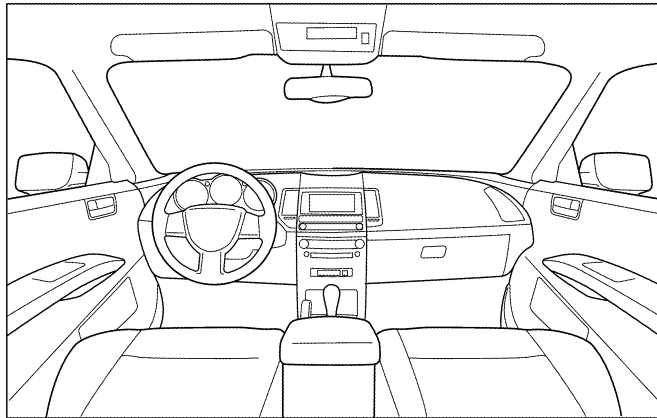

Continue to page 2 of the worksheet and briefly describe the location of the noise or rattle. In addition, please indicate the conditions which are present when the noise occurs.

# SQUEAK AND RATTLE TROUBLE DIAGNOSES

< SYMPTOM DIAGNOSIS >

## SQUEAK & RATTLE DIAGNOSTIC WORKSHEET - page 2

Briefly describe the location where the noise occurs:

---

---

### II. WHEN DOES IT OCCUR? (please check the boxes that apply)

- |   |  |
|---|--|
| <input type="checkbox"/> Anytime                      | <input type="checkbox"/> After sitting out in the rain |
| <input type="checkbox"/> 1st time in the morning      | <input type="checkbox"/> When it is raining or wet     |
| <input type="checkbox"/> Only when it is cold outside | <input type="checkbox"/> Dry or dusty conditions       |
| <input type="checkbox"/> Only when it is hot outside  | <input type="checkbox"/> Other:                        |

### III. WHEN DRIVING:

- Through driveways
- Over rough roads
- Over speed bumps
- Only about \_\_\_\_ mph
- On acceleration
- Coming to a stop
- On turns: left, right or either (circle)
- With passengers or cargo
- Other: \_\_\_\_\_
- After driving \_\_\_\_ miles or \_\_\_\_ minutes

### IV. WHAT TYPE OF NOISE

- Squeak (like tennis shoes on a clean floor)
- Creak (like walking on an old wooden floor)
- Rattle (like shaking a baby rattle)
- Knock (like a knock at the door)
- Tick (like a clock second hand)
- Thump (heavy muffled knock noise)
- Buzz (like a bumble bee)

### TO BE COMPLETED BY DEALERSHIP PERSONNEL

Test Drive Notes:

---

---

---

	YES	NO	Initials of person performing
Vehicle test driven with customer	<input type="checkbox"/>	<input type="checkbox"/>	_____
- Noise verified on test drive	<input type="checkbox"/>	<input type="checkbox"/>	_____
- Noise source located and repaired	<input type="checkbox"/>	<input type="checkbox"/>	_____
- Follow up test drive performed to confirm repair	<input type="checkbox"/>	<input type="checkbox"/>	_____

VIN: \_\_\_\_\_ Customer Name \_\_\_\_\_

W.O.# \_\_\_\_\_ Date: \_\_\_\_\_

This form must be attached to Work Order

LAI/A0071E

A  
B  
C  
D  
E  
F  
G  
H  
I  
INT  
K  
L  
M  
N  
O  
P

# PRECAUTIONS

< PRECAUTION >

## PRECAUTION

### PRECAUTIONS

#### Precaution for Supplemental Restraint System (SRS) "AIR BAG" and "SEAT BELT PRE-TENSIONER"

INFOID:000000009823448

The Supplemental Restraint System such as "AIR BAG" and "SEAT BELT PRE-TENSIONER", used along with a front seat belt, helps to reduce the risk or severity of injury to the driver and front passenger for certain types of collision. This system includes seat belt switch inputs and dual stage front air bag modules. The SRS system uses the seat belt switches to determine the front air bag deployment, and may only deploy one front air bag, depending on the severity of a collision and whether the front occupants are belted or unbelted. Information necessary to service the system safely is included in the SR and SB section of this Service Manual.

#### **WARNING:**

- To avoid rendering the SRS inoperative, which could increase the risk of personal injury or death in the event of a collision which would result in air bag inflation, all maintenance must be performed by an authorized NISSAN/INFINITI dealer.
- Improper maintenance, including incorrect removal and installation of the SRS, can lead to personal injury caused by unintentional activation of the system. For removal of Spiral Cable and Air Bag Module, see the SR section.
- Do not use electrical test equipment on any circuit related to the SRS unless instructed to in this Service Manual. SRS wiring harnesses can be identified by yellow and/or orange harnesses or harness connectors.

#### PRECAUTIONS WHEN USING POWER TOOLS (AIR OR ELECTRIC) AND HAMMERS

#### **WARNING:**

- When working near the Airbag Diagnosis Sensor Unit or other Airbag System sensors with the Ignition ON or engine running, DO NOT use air or electric power tools or strike near the sensor(s) with a hammer. Heavy vibration could activate the sensor(s) and deploy the air bag(s), possibly causing serious injury.
- When using air or electric power tools or hammers, always switch the Ignition OFF, disconnect the battery, and wait at least 3 minutes before performing any service.

#### Precaution Necessary for Steering Wheel Rotation After Battery Disconnect

INFOID:000000009823449

#### **NOTE:**

- This Procedure is applied only to models with Intelligent Key system and NATS (NISSAN ANTI-THEFT SYSTEM).
- Remove and install all control units after disconnecting both battery cables with the ignition knob in the "LOCK" position.
- Always use CONSULT to perform self-diagnosis as a part of each function inspection after finishing work. If DTC is detected, perform trouble diagnosis according to self-diagnostic results.

For models equipped with the Intelligent Key system and NATS, an electrically controlled steering lock mechanism is adopted on the key cylinder.

For this reason, if the battery is disconnected or if the battery is discharged, the steering wheel will lock and steering wheel rotation will become impossible.

If steering wheel rotation is required when battery power is interrupted, follow the procedure below before starting the repair operation.

#### OPERATION PROCEDURE

1. Connect both battery cables.

#### **NOTE:**

Supply power using jumper cables if battery is discharged.

2. Use the Intelligent Key or mechanical key to turn the ignition switch to the "ACC" position. At this time, the steering lock will be released.
3. Disconnect both battery cables. The steering lock will remain released and the steering wheel can be rotated.
4. Perform the necessary repair operation.



# PRECAUTIONS

## < PRECAUTION >

5. When the repair work is completed, return the ignition switch to the "LOCK" position before connecting the battery cables. (At this time, the steering lock mechanism will engage.)
6. Perform a self-diagnosis check of all control units using CONSULT.

### Precaution for Work

INFOID:000000009823450

- When removing or disassembling each component, be careful not to damage or deform it. If a component may be subject to interference, be sure to protect it with a shop cloth.
- When removing (disengaging) components with a screwdriver or similar tool, be sure to wrap the component with a shop cloth or vinyl tape to protect it.
- Protect the removed parts with a shop cloth and prevent them from being dropped.
- Replace a deformed or damaged clip.
- If a part is specified as a non-reusable part, always replace it with a new one.
- Be sure to tighten bolts and nuts securely to the specified torque.
- After installation is complete, be sure to check that each part works properly.
- Follow the steps below to clean components:
  - Water soluble dirt:
    - Dip a soft cloth into lukewarm water, wring the water out of the cloth and wipe the dirty area.
    - Then rub with a soft, dry cloth.
  - Oily dirt:
    - Dip a soft cloth into lukewarm water with mild detergent (concentration: within 2 to 3%) and wipe the dirty area.
    - Then dip a cloth into fresh water, wring the water out of the cloth and wipe the detergent off.
    - Then rub with a soft, dry cloth.
  - Do not use organic solvent such as thinner, benzene, alcohol or gasoline.
  - For genuine leather seats, use a genuine leather seat cleaner.

A  
B  
C  
D  
E  
F  
G  
H  
I  
K  
L  
M  
N  
O  
P

INT

# PREPARATION

< PREPARATION >

## PREPARATION

### PREPARATION

#### Special Service Tool

INFOID:000000009823451

The actual shapes of Kent-Moore tools may differ from those of special service tools illustrated here.

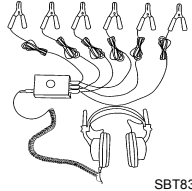
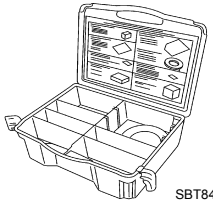
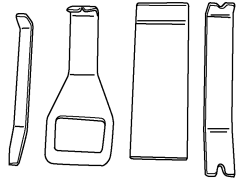
Tool number (Kent-Moore No.) Tool name	Description
— (J-39570) Chassis ear	Locating the noise   SBT839
— (J-43980) NISSAN Squeak and Rattle kit	Repairing the cause of noise   SBT840
— (J-46534) Trim tool set	Removing trim components   AWJIA0483ZZ

#### Commercial Service Tool

INFOID:000000009823452

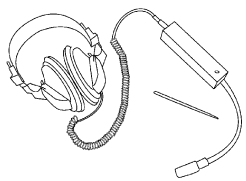
(Kent-Moore No.) Tool name	Description
(J-39565) Engine ear	Locating the noise   SIIA0995E

# CLIP LIST







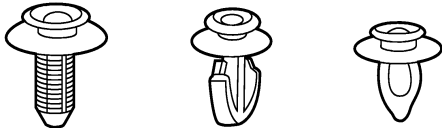

< PREPARATION >

## CLIP LIST

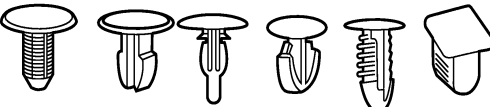
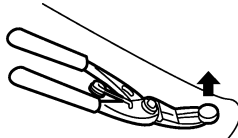
### Descriptions for Clips

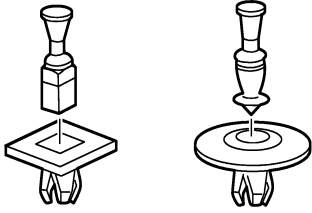
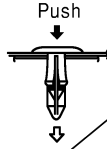
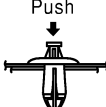
INFOID:000000009823453

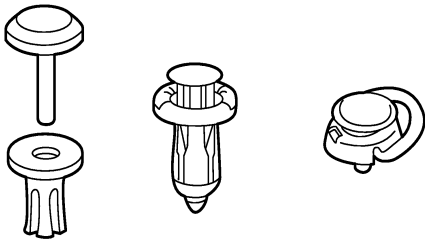
Replace any clips which are damaged during removal or installation.

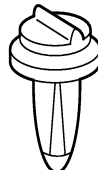
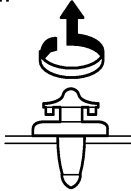





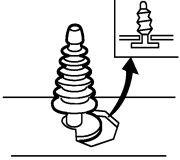
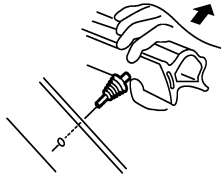

Symbol No.	Shapes	Removal & Installation
C101 		<p><b>Removal:</b> Remove by bending up with flat-bladed screwdrivers or clip remover.</p> 
C103 		 <p><b>Removal:</b> Remove with a clip remover.</p>
C203 		<p><b>Removal:</b> Push center pin to catching position. (Do not remove center pin by hitting it.)</p> <p>Push</p>  <p><b>Installation:</b></p> <p>Push</p> 
C205 		<p><b>Removal:</b></p> <p>Flat-bladed screwdriver</p>  <p>Clip</p> <p>Finisher</p>
C206 		<p><b>Removal:</b></p> 

SIIA0315E

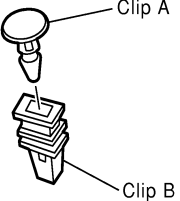
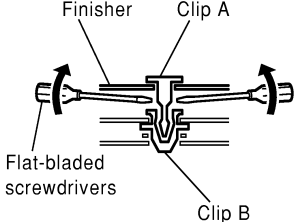
A  
B  
C  
D  
E  
F  
G  
H  
I  
INT  
K  
L  
M  
N  
O  
P

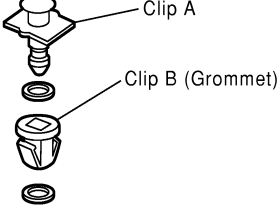
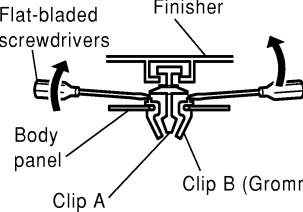
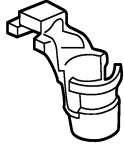
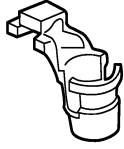
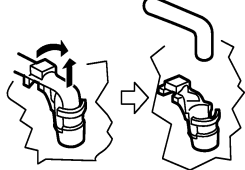
# CLIP LIST

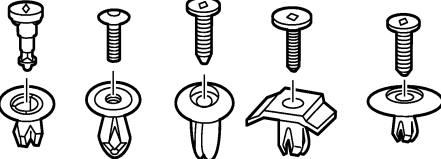









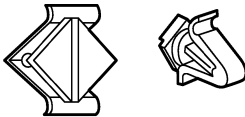

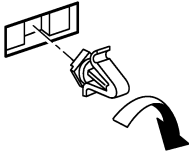
## < PREPARATION >

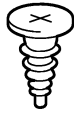
Symbol No.	Shapes	Removal & Installation
<p>CE103</p> 		<p><b>Removal:</b></p> 
<p>CF110</p> 		<p><b>Removal:</b></p> 
<p>CF118</p> 		<p><b>Removal:</b></p> 
<p>CR103</p> 		<p><b>Removal:</b> Holder portion of clip must be spread out to remove rod.</p> 
<p>CS101</p> 		<p><b>Removal:</b></p> <ol style="list-style-type: none"> <li>1. Screw out with a Phillips screwdriver.</li> <li>2. Remove female portion with flat-bladed screwdriver.</li> </ol> 

SIIA0316E

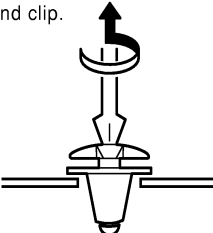
# CLIP LIST

< PREPARATION >





Symbol No.	Shapes	Removal & Installation	
CG101 		<b>Removal:</b>  Rotate 45° to remove	<b>Installation:</b> 
CS102 			
CS113 		<b>Removal:</b> Disconnect upper connection of clip with a flat-bladed screwdriver, then remove clip while inserting a flat-bladed screwdriver between body panel and clip. 	
C111 			

SIIA0317E

A  
B  
C  
D  
E  
F  
G  
H  
I  
INT  
K  
L  
M  
N  
O  
P

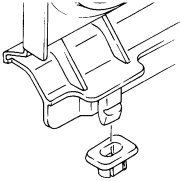
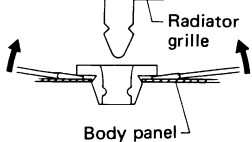
# CLIP LIST

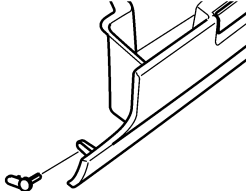
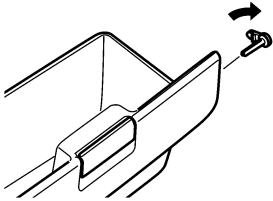
< PREPARATION >

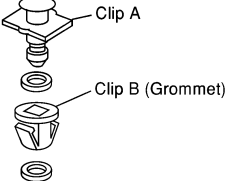
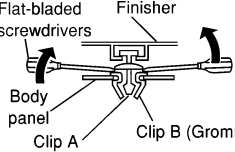
Symbol No.	Shapes	Removal & Installation
<p>CG104</p> 		<p><b>Removal:</b> Remove by bending up with flat-bladed screwdrivers.</p>  <p>Radiator grille Body panel</p>
<p>CE114</p> 		
<p>CF118</p> 	 <p>Clip A Clip B (Grommet)</p>	<p><b>Removal:</b> Flat-bladed screwdrivers Finisher</p>  <p>Body panel Clip A Clip B (Grommet)</p>

ALJIA0564GB

# DOOR FINISHER

< REMOVAL AND INSTALLATION >

## REMOVAL AND INSTALLATION

### DOOR FINISHER

#### Removal and Installation

INFOID:000000009823454

#### FRONT DOOR

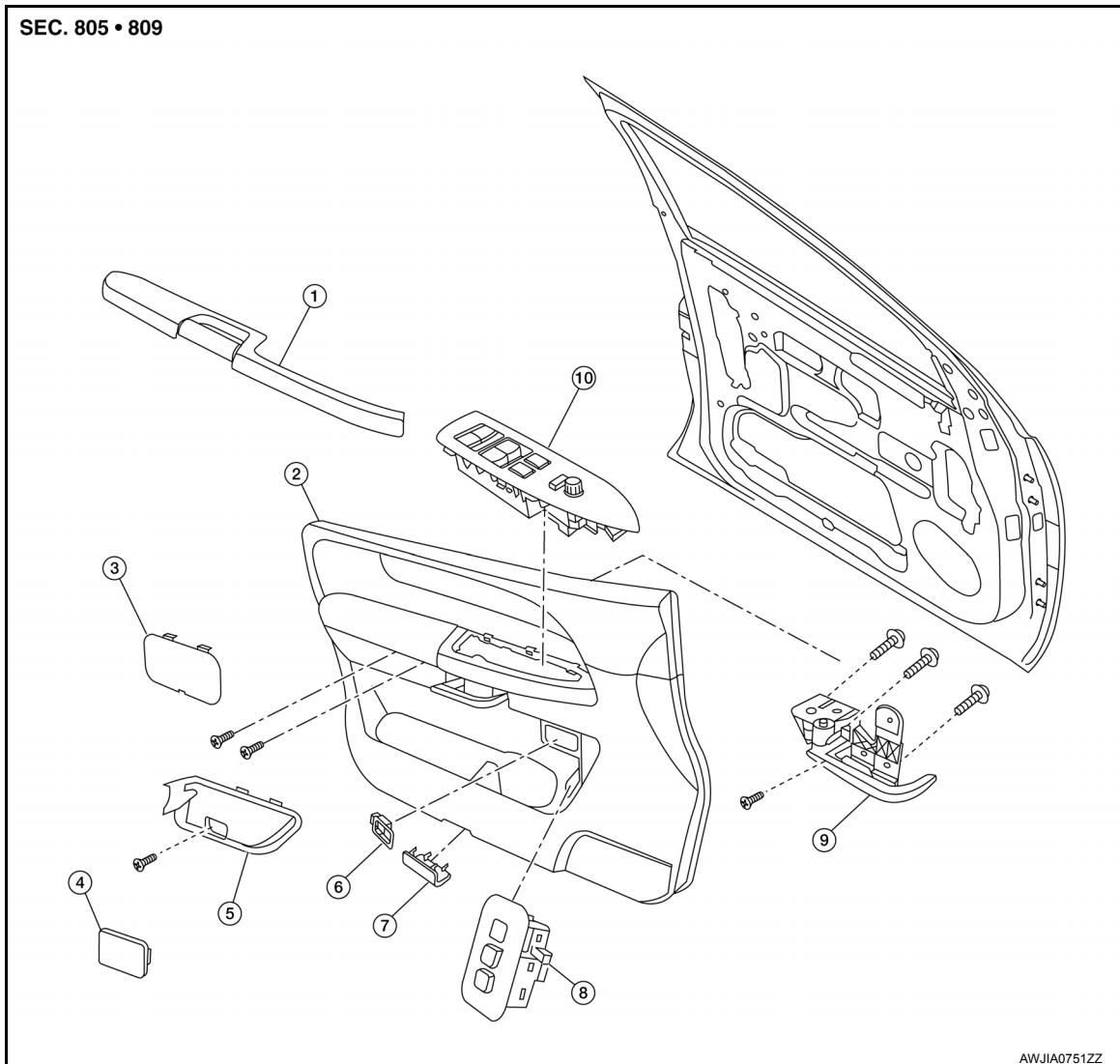

- |                                  |                                     |                                |
|----------------------------------|-------------------------------------|--------------------------------|
| 1. Armrest                       | 2. Front door finisher (LH shown)   | 3. Pull handle cover           |
| 4. Cap                           | 5. Inside door handle escutcheon    | 6. Door lock knob              |
| 7. Step lamp                     | 8. Seat memory switch (if equipped) | 9. Inside door handle assembly |
| 10. Power window switch assembly |                                     |                                |

#### Removal

1. Remove the power window switch assembly. Refer to [PWC-94, "Removal and Installation"](#).
2. Remove the cap from the inside door handle escutcheon and remove screw.
3. Remove the pull handle cover.
  - Remove the screws behind pull handle cover.
4. Remove the seat memory switch (if equipped).
  - Disconnect the harness connector.
5. Remove the step lamp.
  - Disconnect the harness connector.

A  
B  
C  
D  
E  
F  
G  
H  
I  
INT  
K  
L  
M  
N  
O  
P

# DOOR FINISHER

## < REMOVAL AND INSTALLATION >

6. Remove the door finisher and disconnect the lock cable and handle cable from the inside door handle assembly. Refer to [INT-15, "Removal and Installation"](#).
7. Remove the inside door handle assembly.
8. Remove door lock knob.
9. Remove the armrest screws (A), then remove the armrest (1).

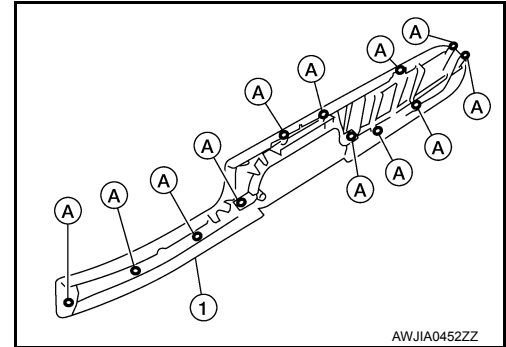

### Installation

Installation is in the reverse order of removal.

### REAR DOOR

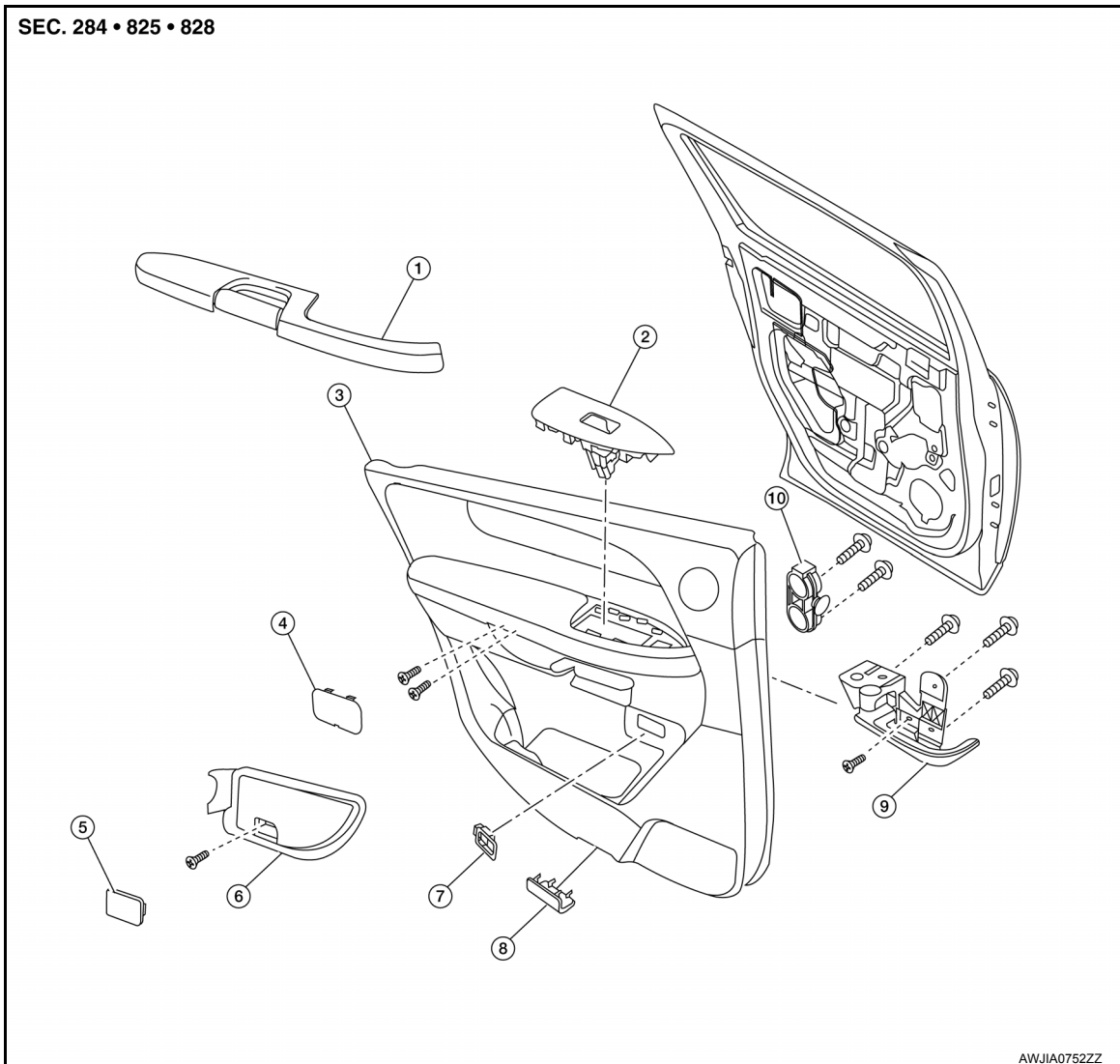

- |                      |                                 |                                  |
|----------------------|---------------------------------|----------------------------------|
| 1. Armrest           | 2. Power window switch assembly | 3. Rear door finisher LH         |
| 4. Pull handle cover | 5. Cap                          | 6. Inside door handle escutcheon |



# DOOR FINISHER

## < REMOVAL AND INSTALLATION >

- 7. Door lock knob
- 8. Step lamp
- 9. Inside door handle assembly
- 10. Rear door tweeter

### Removal

1. Remove the power window switch assembly. Refer to [PWC-94, "Removal and Installation"](#).
2. Remove the pull handle cover.
  - Remove the screws behind the pull handle cover.
3. Remove the cap from the inside door handle escutcheon and the remove screw.
4. Remove the inside door handle escutcheon.
  - Remove the screw behind inside door handle escutcheon.
5. Remove the step lamp.
6. Remove the door finisher and disconnect lock cable and handle cable from inside door handle assembly. Refer to [INT-15, "Removal and Installation"](#).
7. Remove the inside door handle assembly.
8. Remove door lock knob.
9. Remove the rear door tweeter. Refer to [AV-111, "Removal and Installation"](#) (BASE AUDIO), [AV-274, "Removal and Installation"](#) (BOSE AUDIO WITHOUT NAVIGATION) or [AV-456, "Removal and Installation"](#) (BOSE AUDIO WITH NAVIGATION).
10. Remove the armrest screws (A), then remove the armrest (1).

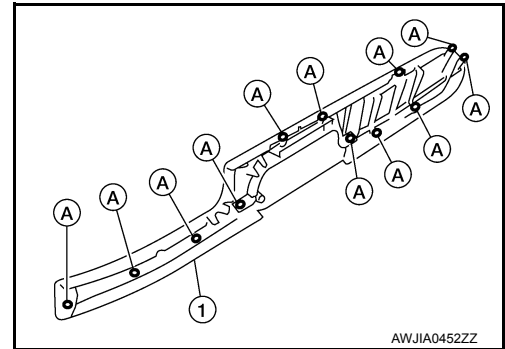

### Installation

Installation is in the reverse order of removal.

# BODY SIDE TRIM

< REMOVAL AND INSTALLATION >

## BODY SIDE TRIM

### Removal and Installation

INFOID:00000009823455

#### CAUTION:

- Wrap the tip of flat-bladed screwdriver with a cloth when removing metal clips from finishers.
- When removing or installing body side welts, do not allow butyl seal to come in contact with pillar finisher.

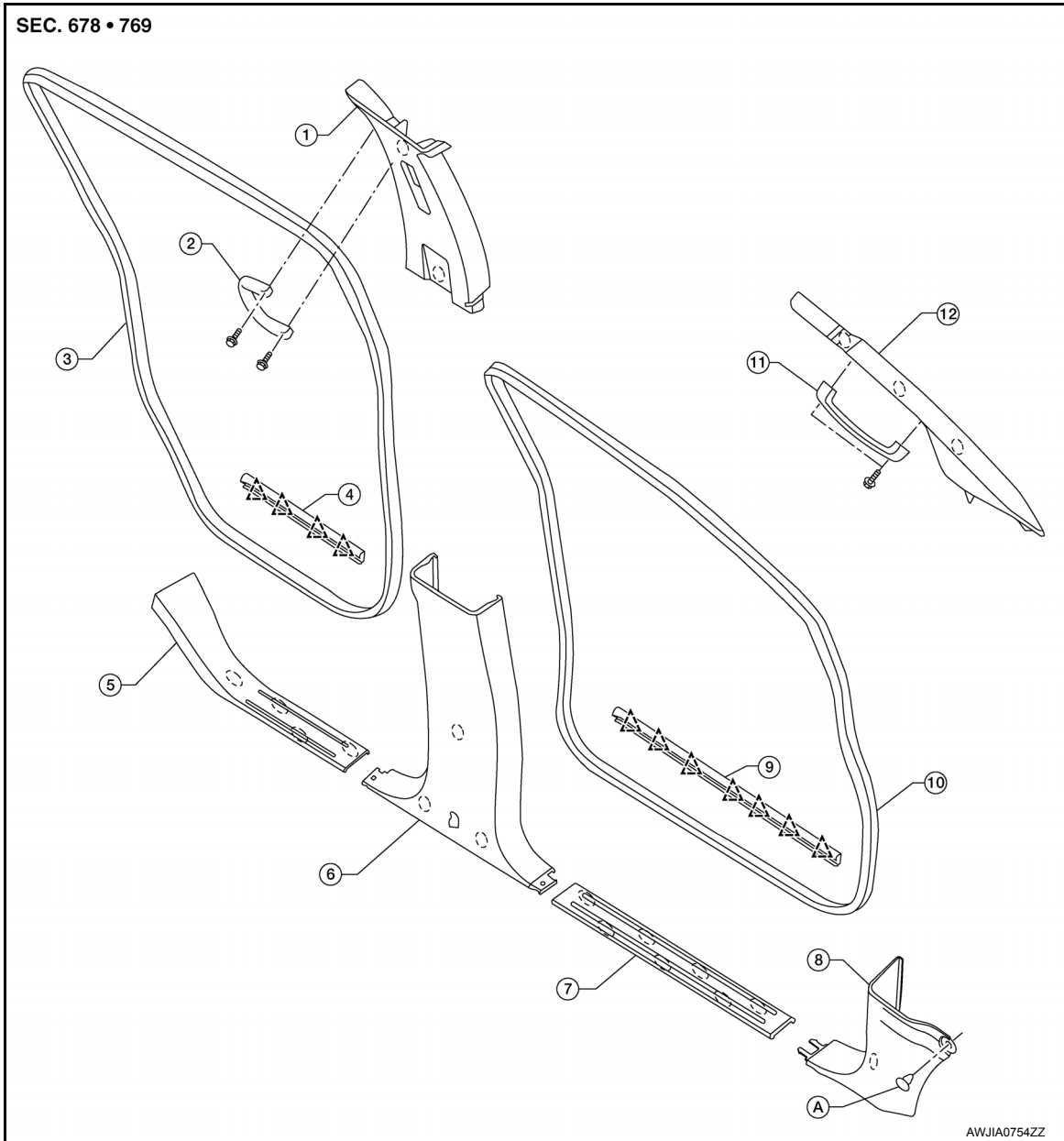

- |                                 |                              |                                 |
|---------------------------------|------------------------------|---------------------------------|
| 1. Center pillar upper finisher | 2. Center pillar assist grip | 3. Rear door welt               |
| 4. Rear door parting seal       | 5. Rear kicking plate        | 6. Center pillar lower finisher |
| 7. Front kicking plate          | 8. Dash side finisher        | 9. Front door parting seal      |
| 10. Front door welt             | 11. Front pillar assist grip | 12. Front pillar finisher       |
| A. Clip                         | ○ Pawl                       | △ Clip                          |

### DASH SIDE FINISHER

#### Removal

1. Remove push pin from dash side finisher.

## BODY SIDE TRIM

### < REMOVAL AND INSTALLATION >

---

2. Remove front kicking plate from center pillar lower finisher.
3. Remove dash side finisher and front kicking plate together.
4. Remove dash side finisher from front kicking plate.

A

#### Installation

Installation is in the reverse order of removal.

B

### CENTER PILLAR LOWER FINISHER

#### Removal

1. Remove seat belt lower anchor. Refer to [SB-13, "Removal and Installation of Front Seat Belt"](#).
  - On RH side, disconnect seat belt tension sensor.
2. Remove front and rear kicking plates.
3. Remove center pillar lower finisher.

C

D

#### Installation

Installation is in the reverse order of removal.

E

### CENTER PILLAR UPPER FINISHER

#### Removal

1. Partially remove front and rear door welts.
2. Remove D-ring anchor bolt cover and anchor bolt. Refer to [SB-13, "Removal and Installation of Front Seat Belt"](#).
3. Remove front and rear kicking plates.
4. Remove center pillar lower finisher.
5. Remove center pillar assist grip covers and bolts, then remove center pillar assist grip.
6. Remove center pillar upper finisher.

F

G

H

#### Installation

Installation is in the reverse order of removal.

I

### FRONT PILLAR FINISHER

#### Removal

1. Remove front pillar assist grip cover(s) and bolt(s), then remove front pillar assist grip.
2. Remove front pillar finisher.

INT

K

#### Installation

Installation is in the reverse order of removal.

L

### KICKING PLATES

#### Removal

Release pawls and remove front and/or rear kicking plates.

M

#### Installation

Installation is in the reverse order of removal.

N

### DOOR PARTING SEALS

#### Removal

1. Open front and/or rear doors fully.
2. Release clips and remove parting seals.

O

#### Installation

Installation is in the reverse order of removal.

P

# FLOOR TRIM

< REMOVAL AND INSTALLATION >

## FLOOR TRIM

### Removal and Installation

INFOID:00000009823456

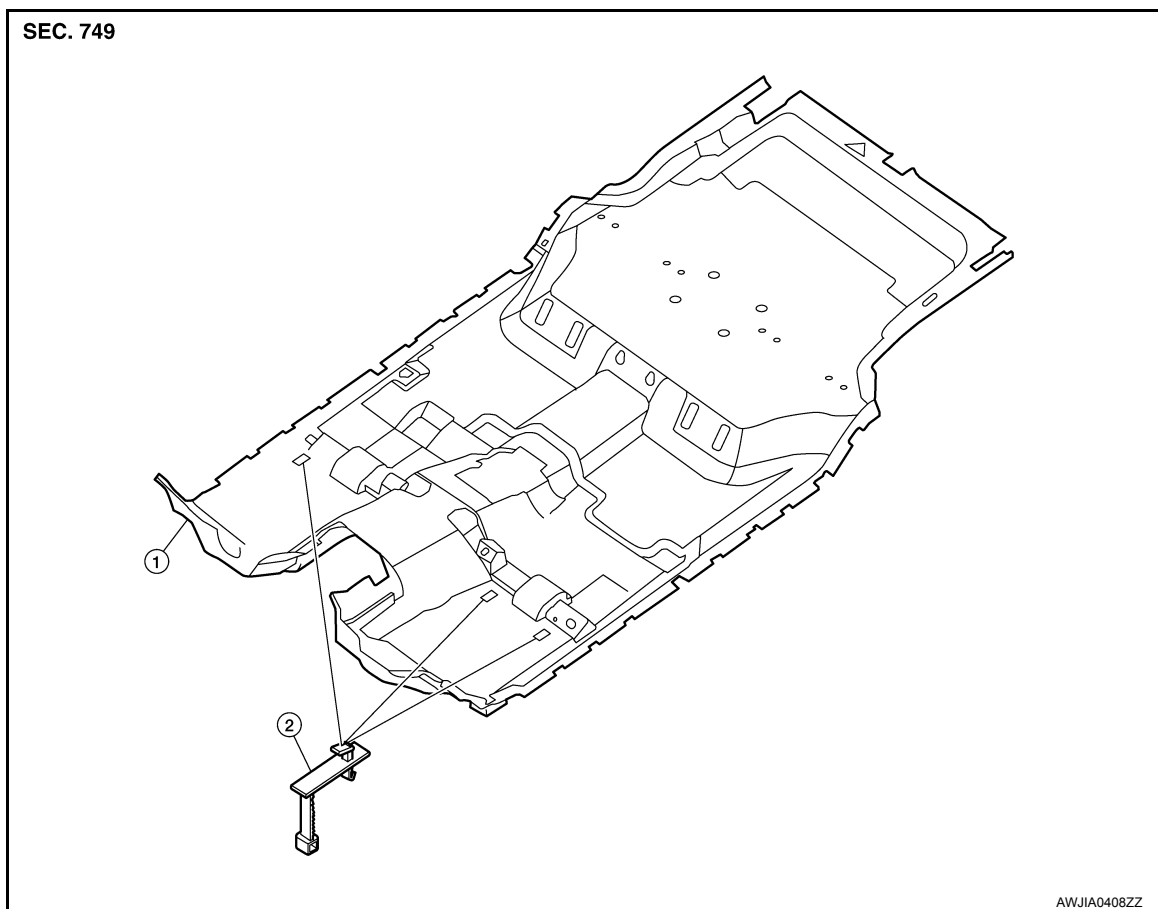

1. Carpet

2. Floor mat hooks

### REMOVAL

1. Remove the front seats. Refer to [SE-63, "Removal and Installation - Front Seat Assembly"](#).
2. Remove the subwoofer. Refer to [AV-276, "Removal and Installation"](#).
3. Remove the navigation display control unit. Refer to [AV-451, "Removal and Installation"](#).
4. Remove the second row seats. Refer to [SE-72, "Removal and Installation - Bucket Seat \(LH/RH\)"](#), [SE-72, "Removal and Installation - Center Seat"](#) and [SE-67, "Exploded View"](#) (if equipped).
5. Remove the third row rear seats. Refer to [SE-78, "Exploded View"](#).
6. Remove the lower seat belt anchors. Refer to [SB-20, "Removal and Installation"](#).
7. Remove the lower body side trim. Refer to [INT-18, "Removal and Installation"](#).
8. Remove the luggage lower side finishers (LH/RH). Refer to [INT-24, "Removal and Installation"](#).
9. Remove the kicking plates. Refer to [INT-18, "Removal and Installation"](#).
10. Remove the center console. Refer to [IP-21, "Removal and Installation"](#).
11. Remove the rear console (if equipped). Refer to [IP-22, "Removal and Installation"](#).
12. Remove the rear lower finisher. Refer to [INT-24, "Removal and Installation"](#).
13. Remove the carpet.
14. Remove the floor mat hooks from the front carpet.

### INSTALLATION

Installation is in the reverse order of removal.

# HEADLINING

< REMOVAL AND INSTALLATION >

## HEADLINING

### Removal and Installation

INFOID:00000009823457

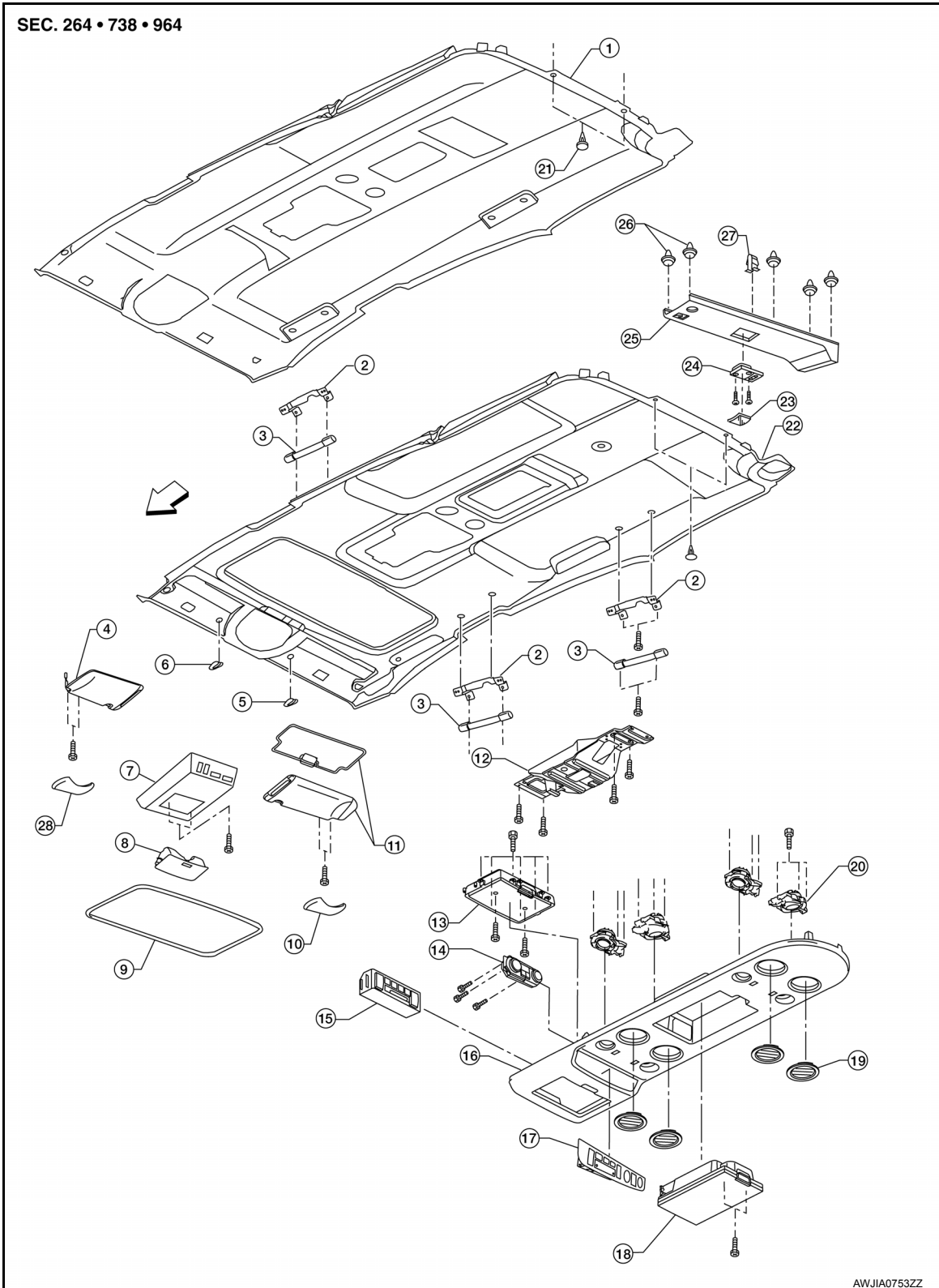

A  
B  
C  
D  
E  
F  
G  
H  
I  
INT  
K  
L  
M  
N  
O  
P

INT

- |                                 |                          |                          |
|---------------------------------|--------------------------|--------------------------|
| 1. Headlining (without sunroof) | 2. Assist grip bracket   | 3. Assist grip           |
| 4. Sun visor assembly (LH)      | 5. Sun visor holder (RH) | 6. Sun visor holder (LH) |
| 7. Front roof console           | 8. Sunglass bin          | 9. Sunroof welt          |

# HEADLINING

## < REMOVAL AND INSTALLATION >

- |                                     |                                |                                 |
|-------------------------------------|--------------------------------|---------------------------------|
| 10. Cap (LH/RH)                     | 11. Sun visor assembly (RH)    | 12. Rear roof console bracket   |
| 13. Rear storage bin or DVD display | 14. Rear air control           | 15. Rear audio control assembly |
| 16. Rear roof console               | 17. Rear roof console finisher | 18. Rear storage bin            |
| 19. Air vent                        | 20. Lamp assembly              | 21. Plastic clip                |
| 22. Headlining (with sunroof)       | 23. Rear lamp lens             | 24. Rear lamp                   |
| 25. Rear roof finisher              | 26. Plastic clips              | 27. Metal clip                  |

⇐ Front

### REMOVAL

#### CAUTION:

**Disconnect both terminals from battery in advance.**

1. Remove the body side trim. Refer to [INT-18](#).
2. Remove the luggage floor trim. Refer to [INT-24](#).
3. Remove the sun visor assemblies.
4. Insert a suitable thin tool (A) at approximately a 30 degree angle into the sun visor holder notch on the front of the sun visor holder (1) and press in the locking tab (B) to release it. While holding in lock tab (B), turn the sun visor holder (1) 90 degrees to release it from the headlining.
  - If the sun visor holder (1) does not fully rotate, make sure that the suitable thin tool (A) is pressing in on the locking tab (B) and is not positioned under locking tab (B). Reinsert the suitable thin tool (A) as necessary to release the locking tab (B).

• ⇐: Front

#### CAUTION:

**Do not force the sun visor holder when removing as the locking tab may be damaged if the suitable thin tool is not positioned correctly.**

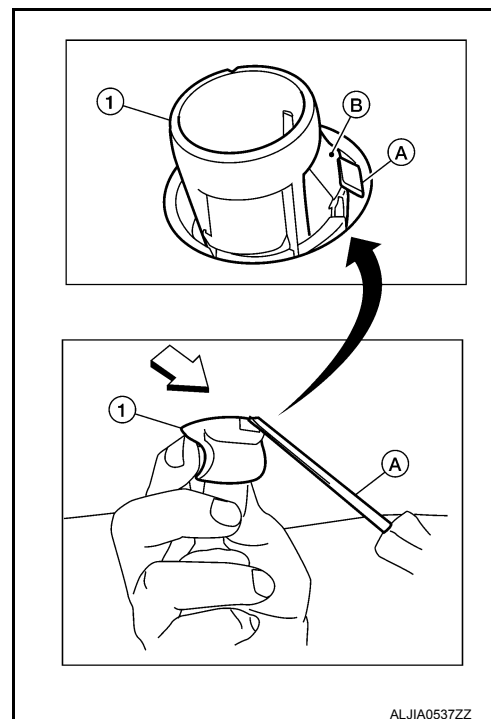

5. Remove the sunroof welt (if equipped).
6. Remove the front roof console.
  - Disconnect the harnesses.
7. Remove the rear roof console.
  - Disconnect the harnesses.
8. Remove the assist grips.
9. Remove the lamp assembly from the rear roof finisher.
  - Disconnect the harness.
10. Remove the rear roof finisher.
11. Remove the headlining.
  - Remove the clips from rear of headlining.
  - Disconnect the harnesses.
12. Remove the rear air control.
  - Disconnect the harness.
13. Remove the rear audio control assembly.
  - Disconnect the harness.
14. Remove the lamp assemblies.
  - Disconnect the harnesses.

# HEADLINING

## < REMOVAL AND INSTALLATION >

---

- 15. Remove the air vents.
- 16. Remove the front roof console bracket.
- 17. Remove the rear roof console front bracket.
- 18. Remove the assist grip brackets from roof.

## INSTALLATION

Installation is in the reverse order of removal.

A

B

C

D

E

F

G

H

I

**INT**

K

L

M

N

O

P

# LUGGAGE FLOOR TRIM

< REMOVAL AND INSTALLATION >

## LUGGAGE FLOOR TRIM

### Removal and Installation

INFOID:00000009823458

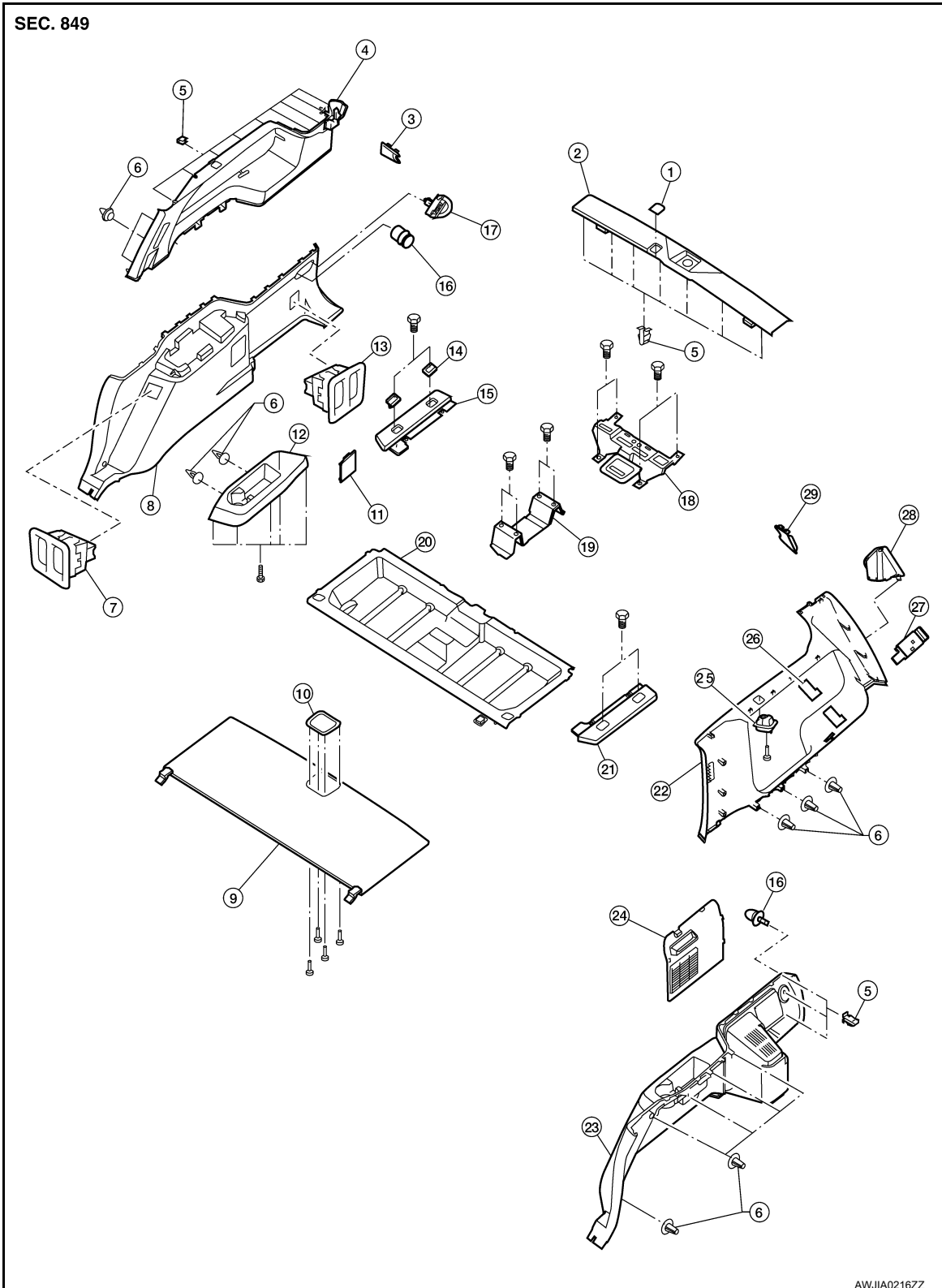

- |  |                                     |                                    |
|--|-------------------------------------|------------------------------------|
| 1. Back kicking plate cap                | 2. Back kicking plate               | 3. Cap upper seat belt finisher RH |
| 4. Luggage side upper finisher (RH)      | 5. Metal clip                       | 6. Plastic clip                    |
| 7. Third row seat switches (if equipped) | 8. Luggage side lower finisher (RH) | 9. Luggage floor board             |



# LUGGAGE FLOOR TRIM

## < REMOVAL AND INSTALLATION >

- |   |                                       |                                 |
|---|---------------------------------------|---------------------------------|
| 10. Latch luggage floor board             | 11. Leak check cap                    | 12. Cup holder                  |
| 13. Third row seat switches (if equipped) | 14. Tie down hook                     | 15. Floor side finisher (RH)    |
| 16. Power point assembly                  | 17. Cargo net hook                    | 18. Rear luggage box bracket    |
| 19. Front luggage floor bracket           | 20. Storage box                       | 21. Floor side finisher (LH)    |
| 22. Luggage side upper finisher (LH)      | 23. Luggage side lower finisher (LH)  | 24. Lid luggage side lower      |
| 25. Coat hook                             | 26. Cap lower seat belt finisher      | 27. Back door open/close switch |
| 28. Cap luggage side upper                | 29. Cap upper seat belt finisher (LH) |                                 |

### REMOVAL

1. Remove 2nd and 3rd row seat belts. Refer to [SB-13, "Removal and Installation of Front Seat Belt"](#), and [SB-16, "Removal and Installation of Third Row Seat Belt"](#).
2. Remove third row seat belt buckles.
3. Remove third row seat assembly. Refer to [SE-78, "Exploded View"](#).
4. Remove back door weatherstrip. Refer to [INT-26, "Removal and Installation"](#).
5. Remove rear luggage room lamp. Refer to [INT-21](#).
  - Disconnect harness connector from lamp.
6. Remove rear upper finisher. Refer to [INT-21](#).
7. Remove rear door kicking plates. Refer to [INT-18](#).
8. Remove back kicking plate.
9. Disconnect door open/close link. Refer to [INT-26, "Removal and Installation"](#).
10. Remove cargo net hooks.
11. Remove luggage side lower finishers (LH/RH).
  - Disconnect power point and the third row seat switch harness connectors RH side (if equipped).
12. Remove coat hooks.
13. Remove luggage side upper finishers (LH/RH).
  - Disconnect harness to door open/close switch, LH side.
14. Remove tie down hooks (LH/RH).
15. Remove floor side finishers (LH/RH).
16. Remove luggage floor board.
17. Remove storage box.
18. Remove front luggage floor bracket.
19. Remove rear luggage box bracket.

### INSTALLATION

Installation is in the reverse order of removal.

A  
B  
C  
D  
E  
F  
G  
H  
I  
INT  
K  
L  
M  
N  
O  
P

# BACK DOOR TRIM

< REMOVAL AND INSTALLATION >

## BACK DOOR TRIM

### Removal and Installation

INFOID:00000009823459

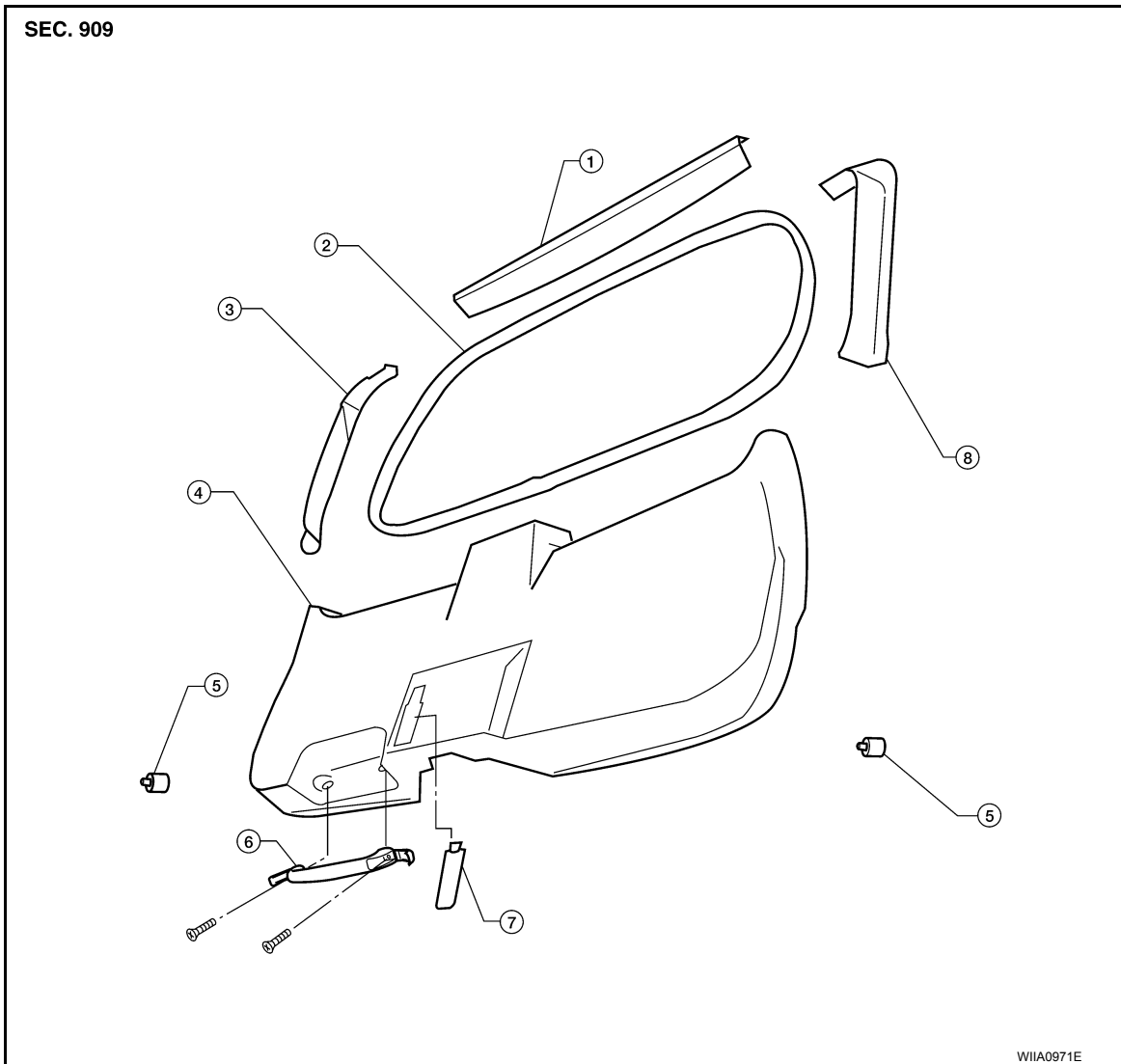

- |                             |                                 |                                 |
|-----------------------------|---------------------------------|---------------------------------|
| 1. Back door upper finisher | 2. Back door glass weatherstrip | 3. Back door side finisher (RH) |
| 4. Back door lower finisher | 5. Back door bumper             | 6. Back door pull handle        |
| 7. Back door mask           | 8. Back door side finisher (LH) |                                 |

### REMOVAL

1. Disconnect door open/close link. Refer to [DLK-241, "Door Lock Assembly"](#).
2. Open back door glass.
3. Remove inside weatherstrip around back door glass.
4. Remove assist handle.
5. Release clips and remove back door lower finisher.
6. Release clips and remove back door upper finisher.
7. Release clips and remove back door side finishers (LH/RH).

### INSTALLATION

Installation is in the reverse order of removal.