

SECTION **GW**

GLASSES, WINDOW SYSTEM & MIRRORS

A
B
C
D
E
F
G
H
J
K
L
M

CONTENTS

PRECAUTIONS	3	POWER WINDOW SERIAL LINK	19
Precautions for Supplemental Restraint System (SRS) "AIR BAG" and "SEAT BELT PRE-TENSIONER"	3	POWER WINDOW LOCK	20
Handling for Adhesive and Primer	3	RETAINED POWER OPERATION	20
PREPARATION	4	ANTI-PINCH SYSTEM	20
Special Service Tool	4	POWER WINDOW CONTROL BY THE FRONT DOOR LOCK ASSEMBLY LH (KEY CYLINDER SWITCH)	20
Commercial Service Tool	4	CAN Communication System Description	20
SQUEAK AND RATTLE TROUBLE DIAGNOSES	5	Schematic	21
Work Flow	5	Wiring Diagram — WINDOW —	23
CUSTOMER INTERVIEW	5	Main Power Window and Door Lock/Unlock Switch Harness Connector Terminal Layout	31
DUPLICATE THE NOISE AND TEST DRIVE	6	Terminals and Reference Values for Main Power Window and Door Lock/Unlock Switch	31
CHECK RELATED SERVICE BULLETINS	6	Power Window and Door Lock/Unlock Switch RH Harness Connector Terminal Layout	32
LOCATE THE NOISE AND IDENTIFY THE ROOT CAUSE	6	Terminals and Reference Values for Power Window and Door Lock/Unlock Switch RH	32
REPAIR THE CAUSE	6	Terminals and Reference Values for BCM	33
CONFIRM THE REPAIR	7	Work Flow	33
Generic Squeak and Rattle Troubleshooting	7	CONSULT-II Function (BCM)	33
INSTRUMENT PANEL	7	CONSULT-II START PROCEDURE	33
CENTER CONSOLE	7	ACTIVE TEST	33
DOORS	7	WORK SUPPORT	34
TRUNK	8	DATA MONITOR	34
SUNROOF/HEADLINING	8	Trouble Diagnoses Symptom Chart	34
OVERHEAD CONSOLE (FRONT AND REAR).....	8	BCM Power Supply and Ground Circuit Check	35
SEATS	8	Main Power Window and Door Lock/Unlock Switch Power Supply and Ground Circuit Check	35
UNDERHOOD	8	Power Window and Door Lock/Unlock Switch RH Power Supply and Ground Circuit Check	36
Diagnostic Worksheet	9	Front Power Window Motor LH Circuit Check	38
WINDSHIELD GLASS	11	Front Power Window Motor RH Circuit Check	38
Removal and Installation	11	Limit Switch Circuit Check Front LH	39
REMOVAL	11	Limit Switch Circuit Check Front RH	41
INSTALLATION	11	Encoder Circuit Check Front LH	42
REAR WINDOW GLASS AND MOLDING	14	Encoder Circuit Check Front RH	44
Removal and Installation	14	Door Switch Check	46
REMOVAL	14	Front Door Lock Assembly (Key Cylinder Switch) Check	47
INSTALLATION	15		
POWER WINDOW SYSTEM	16		
Component Parts and Harness Connector Location	16		
System Description	16		
MANUAL OPERATION	17		
AUTO OPERATION	19		

GW

Power Window Serial Link Check Front LH and RH..	49	Work Flow	75
Rear Power Window Motor LH Circuit Check	51	CONSULT-II Function (BCM)	75
Rear Power Window Motor RH Circuit Check	52	CONSULT-II START PROCEDURE	75
Rear Power Vent Window Switch Circuit Check	53	DATA MONITOR	75
Rear Power Vent Window Motor LH Circuit Check..	54	ACTIVE TEST	75
Rear Power Vent Window Motor RH Circuit Check..	54	Trouble Diagnoses Symptom Chart	75
Rear Power Vent Window Relay (OPEN) Check ...	55	BCM Power Supply and Ground Circuit Check	76
Rear Power Vent Window Relay (CLOSE) Check..	56	Rear Window Defogger Switch Circuit Check	76
FRONT DOOR GLASS AND REGULATOR	58	Rear Window Defogger Power Supply Circuit	
Removal and Installation	58	Check	77
FRONT DOOR GLASS	58	Rear Window Defogger Circuit Check	78
FRONT DOOR GLASS REGULATOR	59	Door Mirror Defogger Power Supply Circuit Check	
SETTING AFTER INSTALLATION	59	(Without Automatic Drive Positioner)	78
REAR DOOR GLASS AND REGULATOR	61	Door Mirror Defogger Power Supply Circuit Check	
Removal and Installation	61	(With Automatic Drive Positioner)	80
REAR DOOR GLASS	61	DoorMirrorLH(DoorMirrorDefogger)CircuitCheck	
REAR DOOR GLASS REGULATOR	62	(Without Automatic Drive Positioner)	81
SIDE WINDOW GLASS	64	DoorMirrorLH(DoorMirrorDefogger)CircuitCheck	
Removal and Installation (without Rear Power Vent		(With Automatic Drive Positioner)	82
Windows)	64	Door Mirror RH (Door Mirror Defogger) Circuit	
REMOVAL	64	Check (Without Automatic Drive Positioner)	83
INSTALLATION	64	Door Mirror RH (Door Mirror Defogger) Circuit	
Removal and Installation (with Rear Power Vent		Check (With Automatic Drive Positioner)	84
Windows)	65	Rear Window Defogger Signal Check	85
REMOVAL	65	Filament Check	85
INSTALLATION	65	Filament Repair	86
INSIDE MIRROR	66	REPAIR EQUIPMENT	86
Wiring Diagram — I/MIRR —	66	REPAIRING PROCEDURE	86
Removal and Installation	67	DOOR MIRROR	88
INSIDE MIRROR	67	Wiring Diagram — MIRROR — (Without Power	
REAR WINDOW DEFOGGER	68	Folding Mirrors)	88
Component Parts and Harness Connector Location..	68	Door Mirror Assembly	90
System Description	69	REMOVAL	90
CAN Communication System Description	70	INSTALLATION	90
Schematic	71	Door Mirror Glass	91
Wiring Diagram — DEF —	72	REMOVAL	91
Terminals and Reference Values for BCM	75	INSTALLATION	91
Terminals and Reference Values for IPDM E/R	75		

PRECAUTIONS

PRECAUTIONS

PF:00001

Precautions for Supplemental Restraint System (SRS) “AIR BAG” and “SEAT BELT PRE-TENSIONER”

EIS009YF

The Supplemental Restraint System such as “AIR BAG” and “SEAT BELT PRE-TENSIONER”, used along with a front seat belt, helps to reduce the risk or severity of injury to the driver and front passenger for certain types of collision. This system includes seat belt switch inputs and dual stage front air bag modules. The SRS system uses the seat belt switches to determine the front air bag deployment, and may only deploy one front air bag, depending on the severity of a collision and whether the front occupants are belted or unbelted. Information necessary to service the system safely is included in the SRS and SB section of this Service Manual.

WARNING:

- To avoid rendering the SRS inoperative, which could increase the risk of personal injury or death in the event of a collision which would result in air bag inflation, all maintenance must be performed by an authorized NISSAN/INFINITI dealer.
- Improper maintenance, including incorrect removal and installation of the SRS, can lead to personal injury caused by unintentional activation of the system. For removal of Spiral Cable and Air Bag Module, see the SRS section.
- Do not use electrical test equipment on any circuit related to the SRS unless instructed to in this Service Manual. SRS wiring harnesses can be identified by yellow and/or orange harnesses or harness connectors.

Handling for Adhesive and Primer

EIS009YG

- Do not use an adhesive which is past its usable date. Shelf life of this product is limited to six months after the date of manufacture. Carefully adhere to the expiration or manufacture date printed on the box.
- Keep primers and adhesive in a cool, dry place. Ideally, they should be stored in a refrigerator.
- Open the seal of the primer and adhesive just before application. Discard the remainder.
- Before application, be sure to shake the primer container to stir the contents. If any floating material is found, do not use it.
- If any primer or adhesive contacts the skin, wipe it off with gasoline or equivalent and wash the skin with soap.
- When using primer and adhesive, always observe the precautions in the instruction manual.

A
B
C
D
E
F
G
H
J
K
L
M

GW

PREPARATION

PREPARATION

PFP:00002

Special Service Tool

EIS009YH

The actual shapes of Kent-Moore tools may differ from those of special service tools illustrated here.

Tool number (Kent-Moore No.) Tool name	Description
— (J-39570) Chassis ear	Locating the noise
(J-43980) NISSAN Squeak and Rattle Kit	Repairing the cause of noise

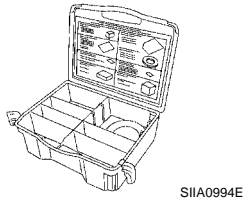
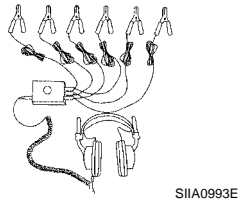

Commercial Service Tool

EIS009YI

Tool name (Kent-Moore No.)	Description
Engine ear (J-39565)	Locating the noise
Suction Lifter (—)	Holding door glass

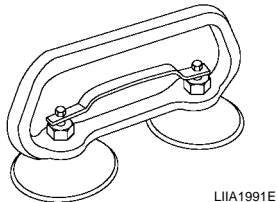
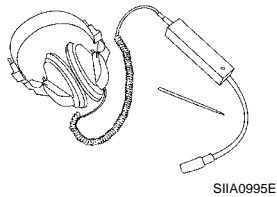

SQUEAK AND RATTLE TROUBLE DIAGNOSES

SQUEAK AND RATTLE TROUBLE DIAGNOSES

PF0:0000

Work Flow

EIS009YJ

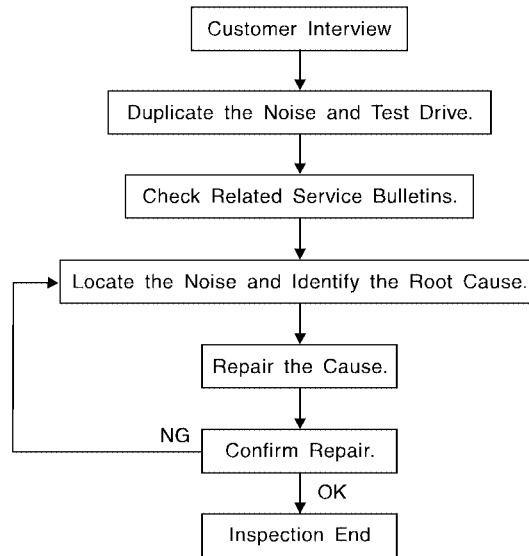

SBT842

CUSTOMER INTERVIEW

Interview the customer if possible, to determine the conditions that exist when the noise occurs. Use the Diagnostic Worksheet during the interview to document the facts and conditions when the noise occurs and any customer's comments; refer to [GW-9, "Diagnostic Worksheet"](#). This information is necessary to duplicate the conditions that exist when the noise occurs.

- The customer may not be able to provide a detailed description or the location of the noise. Attempt to obtain all the facts and conditions that exist when the noise occurs (or does not occur).
- If there is more than one noise in the vehicle, be sure to diagnose and repair the noise that the customer is concerned about. This can be accomplished by test driving the vehicle with the customer.
- After identifying the type of noise, isolate the noise in terms of its characteristics. The noise characteristics are provided so the customer, service adviser and technician are all speaking the same language when defining the noise.
- Squeak —(Like tennis shoes on a clean floor)
Squeak characteristics include the light contact/fast movement/brought on by road conditions/hard surfaces = higher pitch noise/softer surfaces = lower pitch noises/edge to surface = chirping.
- Creak—(Like walking on an old wooden floor)
Creak characteristics include firm contact/slow movement/twisting with a rotational movement/pitch dependent on materials/often brought on by activity.
- Rattle—(Like shaking a baby rattle)
Rattle characteristics include the fast repeated contact/vibration or similar movement/loose parts/missing clip or fastener/incorrect clearance.
- Knock —(Like a knock on a door)
Knock characteristics include hollow sounding/sometimes repeating/often brought on by driver action.
- Tick—(Like a clock second hand)
Tick characteristics include gentle contacting of light materials/loose components/can be caused by driver action or road conditions.
- Thump—(Heavy, muffled knock noise)
Thump characteristics include softer knock/dead sound often brought on by activity.
- Buzz—(Like a bumble bee)
Buzz characteristics include high frequency rattle/firm contact.
- Often the degree of acceptable noise level will vary depending upon the person. A noise that you may judge as acceptable may be very irritating to the customer.
- Weather conditions, especially humidity and temperature, may have a great effect on noise level.

SQUEAK AND RATTLE TROUBLE DIAGNOSES

DUPLICATE THE NOISE AND TEST DRIVE

If possible, drive the vehicle with the customer until the noise is duplicated. Note any additional information on the Diagnostic Worksheet regarding the conditions or location of the noise. This information can be used to duplicate the same conditions when you confirm the repair.

If the noise can be duplicated easily during the test drive, to help identify the source of the noise, try to duplicate the noise with the vehicle stopped by doing one or all of the following:

- 1) Close a door.
 - 2) Tap or push/pull around the area where the noise appears to be coming from.
 - 3) Rev the engine.
 - 4) Use a floor jack to recreate vehicle "twist".
 - 5) At idle, apply engine load (electrical load, half-clutch on M/T model, drive position on A/T model).
 - 6) Raise the vehicle on a hoist and hit a tire with a rubber hammer.
- Drive the vehicle and attempt to duplicate the conditions the customer states exist when the noise occurs.
 - If it is difficult to duplicate the noise, drive the vehicle slowly on an undulating or rough road to stress the vehicle body.

CHECK RELATED SERVICE BULLETINS

After verifying the customer concern or symptom, check ASIST for Technical Service Bulletins (TSBs) related to that concern or symptom.

If a TSB relates to the symptom, follow the procedure to repair the noise.

LOCATE THE NOISE AND IDENTIFY THE ROOT CAUSE

1. Narrow down the noise to a general area. To help pinpoint the source of the noise, use a listening tool (Chassis Ear: J-39570, Engine Ear: J-39565 and mechanic's stethoscope).
2. Narrow down the noise to a more specific area and identify the cause of the noise by:
 - removing the components in the area that you suspect the noise is coming from. Do not use too much force when removing clips and fasteners, otherwise clips and fasteners can be broken or lost during the repair, resulting in the creation of new noise.
 - tapping or pushing/pulling the component that you suspect is causing the noise. Do not tap or push/pull the component with excessive force, otherwise the noise will be eliminated only temporarily.
 - feeling for a vibration with your hand by touching the component(s) that you suspect is (are) causing the noise.
 - placing a piece of paper between components that you suspect are causing the noise.
 - looking for loose components and contact marks.
Refer to [GW-7, "Generic Squeak and Rattle Troubleshooting"](#) .

REPAIR THE CAUSE

- If the cause is a loose component, tighten the component securely.
- If the cause is insufficient clearance between components:
 - separate components by repositioning or loosening and retightening the component, if possible.
 - insulate components with a suitable insulator such as urethane pads, foam blocks, felt cloth tape or urethane tape. A NISSAN Squeak and Rattle Kit (J-43980) is available through your authorized NISSAN Parts Department.

CAUTION:

Do not use excessive force as many components are constructed of plastic and may be damaged.

Always check with the Parts Department for the latest parts information.

The following materials are contained in the NISSAN Squeak and Rattle Kit (J-43980). Each item can be ordered separately as needed.

URETHANE PADS [1.5 mm (0.059 in) thick]

Insulates connectors, harness, etc.

76268-9E005: 100×135 mm (3.94×5.31 in)/76884-71L01: 60×85 mm (2.36×3.35 in)/76884-71L02: 15×25 mm (0.59×0.98 in)

INSULATOR (Foam blocks)

Insulates components from contact. Can be used to fill space behind a panel.

73982-9E000: 45 mm (1.77 in) thick, 50×50 mm (1.97×1.97 in)/73982-50Y00: 10 mm (0.39 in) thick, 50×50 mm (1.97×1.97 in)

INSULATOR (Light foam block)

SQUEAK AND RATTLE TROUBLE DIAGNOSES

80845-71L00: 30 mm (1.18 in) thick, 30×50 mm (1.18×1.97 in)

FELT CLOTH TAPE

Used to insulate where movement does not occur. Ideal for instrument panel applications.

68370-4B000: 15×25 mm (0.59×0.98 in) pad/68239-13E00: 5 mm (0.20 in) wide tape roll. The following materials not found in the kit can also be used to repair squeaks and rattles.

UHMW (TEFLON) TAPE

Insulates where slight movement is present. Ideal for instrument panel applications.

SILICONE GREASE

Used instead of UHMW tape that will be visible or not fit.

Note: Will only last a few months.

SILICONE SPRAY

Use when grease cannot be applied.

DUCT TAPE

Use to eliminate movement.

CONFIRM THE REPAIR

Confirm that the cause of a noise is repaired by test driving the vehicle. Operate the vehicle under the same conditions as when the noise originally occurred. Refer to the notes on the Diagnostic Worksheet.

Generic Squeak and Rattle Troubleshooting

EIS009YK

Refer to Table of Contents for specific component removal and installation information.

INSTRUMENT PANEL

Most incidents are caused by contact and movement between:

1. The cluster lid A and instrument panel
2. Acrylic lens and combination meter housing
3. Instrument panel to front pillar garnish
4. Instrument panel to windshield
5. Instrument panel mounting pins
6. Wiring harnesses behind the combination meter
7. A/C defroster duct and duct joint

These incidents can usually be located by tapping or moving the components to duplicate the noise or by pressing on the components while driving to stop the noise. Most of these incidents can be repaired by applying felt cloth tape or silicone spray (in hard to reach areas). Urethane pads can be used to insulate wiring harness.

CAUTION:

Do not use silicone spray to isolate a squeak or rattle. If you saturate the area with silicone, you will not be able to recheck the repair.

CENTER CONSOLE

Components to pay attention to include:

1. Shifter assembly cover to finisher
2. A/C control unit and cluster lid C
3. Wiring harnesses behind audio and A/C control unit

The instrument panel repair and isolation procedures also apply to the center console.

DOORS

Pay attention to the:

1. Finisher and inner panel making a slapping noise
2. Inside handle escutcheon to door finisher
3. Wiring harnesses tapping
4. Door striker out of alignment causing a popping noise on starts and stops

Tapping or moving the components or pressing on them while driving to duplicate the conditions can isolate many of these incidents. You can usually insulate the areas with felt cloth tape or insulator foam blocks from the NISSAN Squeak and Rattle Kit (J-43980) to repair the noise.

SQUEAK AND RATTLE TROUBLE DIAGNOSES

TRUNK

Trunk noises are often caused by a loose jack or loose items put into the trunk by the owner. In addition look for:

1. Trunk lid bumpers out of adjustment
2. Trunk lid striker out of adjustment
3. The trunk lid torsion bars knocking together
4. A loose license plate or bracket

Most of these incidents can be repaired by adjusting, securing or insulating the item(s) or component(s) causing the noise.

SUNROOF/HEADLINING

Noises in the sunroof/headlining area can often be traced to one of the following:

1. Sunroof lid, rail, linkage or seals making a rattle or light knocking noise
2. Sun visor shaft shaking in the holder
3. Front or rear windshield touching headliner and squeaking

Again, pressing on the components to stop the noise while duplicating the conditions can isolate most of these incidents. Repairs usually consist of insulating with felt cloth tape.

OVERHEAD CONSOLE (FRONT AND REAR)

Overhead console noises are often caused by the console panel clips not being engaged correctly. Most of these incidents are repaired by pushing up on the console at the clip locations until the clips engage.

In addition look for:

1. Loose harness or harness connectors.
2. Front console map/reading lamp lense loose.
3. Loose screws at console attachment points.

SEATS

When isolating seat noise it's important to note the position the seat is in and the load placed on the seat when the noise is present. These conditions should be duplicated when verifying and isolating the cause of the noise.

Cause of seat noise include:

1. Headrest rods and holder
2. A squeak between the seat pad cushion and frame
3. The rear seatback lock and bracket

These noises can be isolated by moving or pressing on the suspected components while duplicating the conditions under which the noise occurs. Most of these incidents can be repaired by repositioning the component or applying urethane tape to the contact area.

UNDERHOOD

Some interior noise may be caused by components under the hood or on the engine wall. The noise is then transmitted into the passenger compartment.

Causes of transmitted underhood noise include:

1. Any component mounted to the engine wall
2. Components that pass through the engine wall
3. Engine wall mounts and connectors
4. Loose radiator mounting pins
5. Hood bumpers out of adjustment
6. Hood striker out of adjustment

These noises can be difficult to isolate since they cannot be reached from the interior of the vehicle. The best method is to secure, move or insulate one component at a time and test drive the vehicle. Also, engine RPM or load can be changed to isolate the noise. Repairs can usually be made by moving, adjusting, securing, or insulating the component causing the noise.

SQUEAK AND RATTLE TROUBLE DIAGNOSES

EIS009YL

Diagnostic Worksheet

Dear Customer:

We are concerned about your satisfaction with your vehicle. Repairing a squeak or rattle sometimes can be very difficult. To help us fix your vehicle right the first time, please take a moment to note the area of the vehicle where the squeak or rattle occurs and under what conditions. You may be asked to take a test drive with a service advisor or technician to ensure we confirm the noise you are hearing.

SQUEAK & RATTLE DIAGNOSTIC WORKSHEET

I. WHERE DOES THE NOISE COME FROM? (circle the area of the vehicle)

The illustrations are for reference only, and may not reflect the actual configuration of your vehicle.

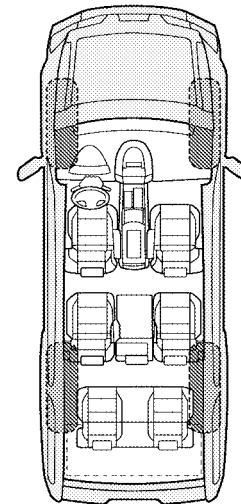
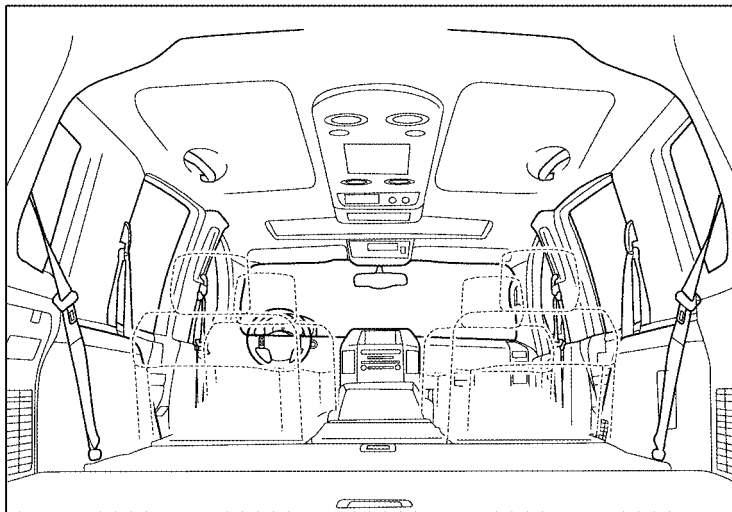
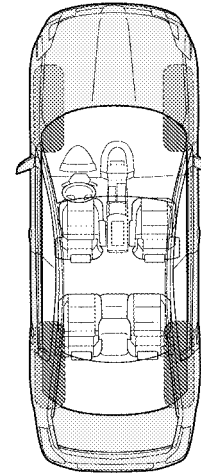
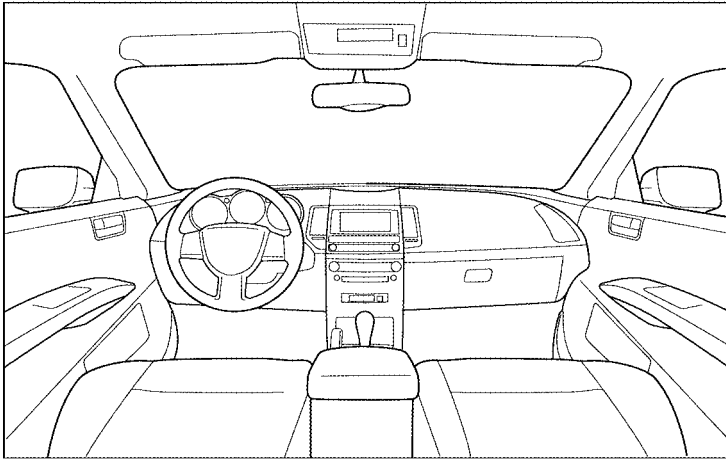

Continue to page 2 of the worksheet and briefly describe the location of the noise or rattle. In addition, please indicate the conditions which are present when the noise occurs.

A
B
C
D
E
F
G
H
GW
J
K
L
M

SQUEAK AND RATTLE TROUBLE DIAGNOSES

SQUEAK & RATTLE DIAGNOSTIC WORKSHEET - page 2

Briefly describe the location where the noise occurs:

II. WHEN DOES IT OCCUR? (please check the boxes that apply)

- | | |
|---|--|
| <input type="checkbox"/> Anytime | <input type="checkbox"/> After sitting out in the rain |
| <input type="checkbox"/> 1st time in the morning | <input type="checkbox"/> When it is raining or wet |
| <input type="checkbox"/> Only when it is cold outside | <input type="checkbox"/> Dry or dusty conditions |
| <input type="checkbox"/> Only when it is hot outside | <input type="checkbox"/> Other: |

III. WHEN DRIVING:

- Through driveways
- Over rough roads
- Over speed bumps
- Only about ____ mph
- On acceleration
- Coming to a stop
- On turns: left, right or either (circle)
- With passengers or cargo
- Other: _____
- After driving ____ miles or ____ minutes

IV. WHAT TYPE OF NOISE

- Squeak (like tennis shoes on a clean floor)
- Creak (like walking on an old wooden floor)
- Rattle (like shaking a baby rattle)
- Knock (like a knock at the door)
- Tick (like a clock second hand)
- Thump (heavy muffled knock noise)
- Buzz (like a bumble bee)

TO BE COMPLETED BY DEALERSHIP PERSONNEL

Test Drive Notes:

	YES	NO	Initials of person performing
Vehicle test driven with customer	<input type="checkbox"/>	<input type="checkbox"/>	_____
- Noise verified on test drive	<input type="checkbox"/>	<input type="checkbox"/>	_____
- Noise source located and repaired	<input type="checkbox"/>	<input type="checkbox"/>	_____
- Follow up test drive performed to confirm repair	<input type="checkbox"/>	<input type="checkbox"/>	_____

LAI0071E

WINDSHIELD GLASS

PFP:72712

WINDSHIELD GLASS

Removal and Installation

EIS009YM

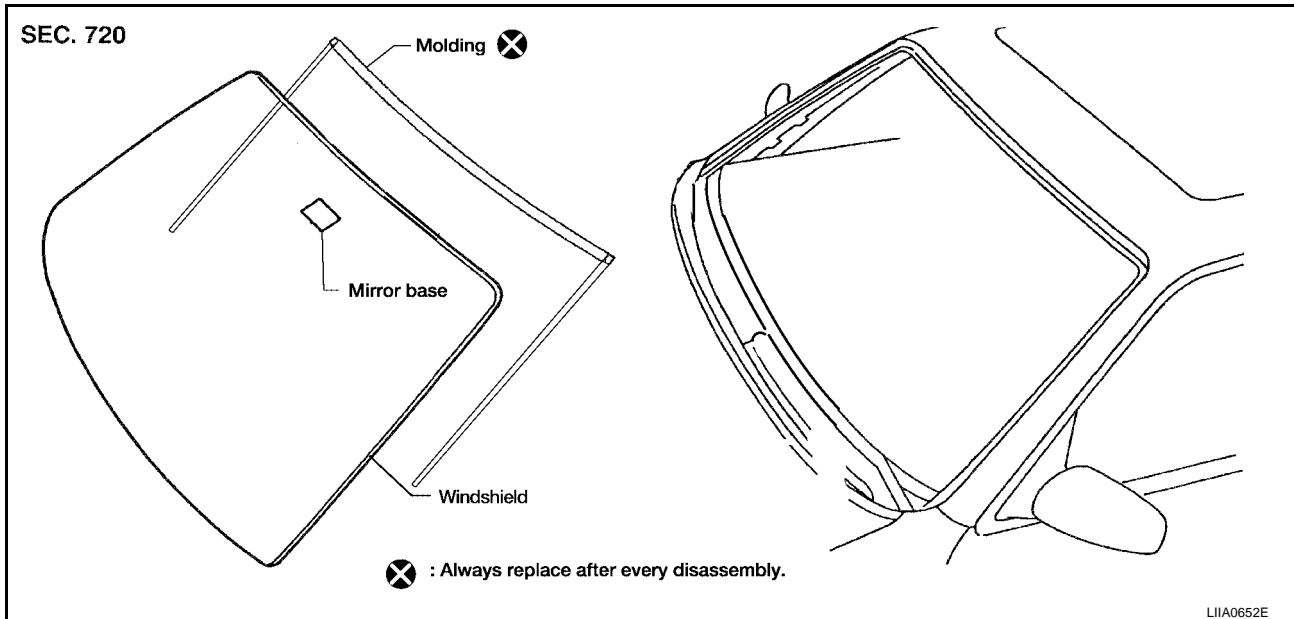

REMOVAL

1. Remove inside mirror. Refer to [GW-67, "INSIDE MIRROR"](#).
 2. Partially remove the headlining (front edge). Refer to [EI-35, "HEADLINING"](#).
 3. Remove cowl top cover. Refer to [EI-18, "COWL TOP"](#).
 4. Apply a protective tape around the windshield glass to protect the painted surface from damage.
- Remove glass using piano wire or power cutting tool and an inflatable pump bag.
 - If the windshield glass is to be reused, mark the body and the glass with mating marks.

WARNING:

When cutting the glass from the vehicle, always wear safety glasses and heavy gloves to help prevent glass splinters from entering your eyes or cutting your hands.

CAUTION:

- When the windshield glass is to be reused, do not use a cutting knife or power cutting tool.
- Be careful not to scratch the glass when removing.
- Do not set or stand glass on its edge. Small chips may develop into cracks.

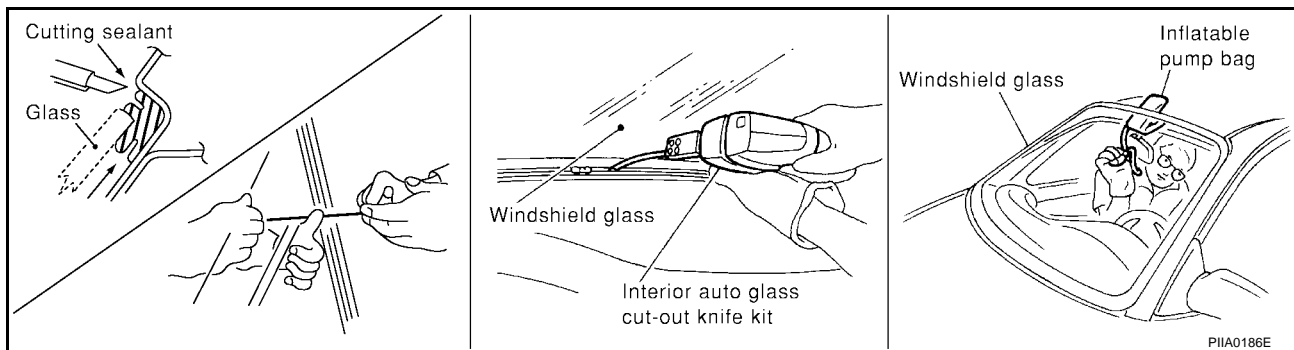

INSTALLATION

- Use a genuine NISSAN Urethane Adhesive Kit (if available) or equivalent and follow the instructions furnished with it.
- While the urethane adhesive is curing, open a door window. This will prevent the glass from being forced out by passenger compartment air pressure when a door is closed.
- The molding must be installed securely so that it is in position and leaves no gap.

WINDSHIELD GLASS

- Inform the customer that the vehicle should remain stationary until the urethane adhesive has completely cured (preferably 24 hours). Curing time varies with temperature and humidity.
- Install parts removed.

WARNING:

- Keep heat and open flames away as primers and adhesive are flammable.
- The materials contained in the kit are harmful if swallowed, and may irritate skin and eyes. Avoid contact with the skin and eyes.
- Use in an open, well ventilated location. Avoid breathing the vapors. They can be harmful if inhaled. If affected by vapor inhalation, immediately move to an area with fresh air.
- Driving the vehicle before the urethane adhesive has completely cured may affect the performance of the windshield in case of an accident.

CAUTION:

- Do not use an adhesive which is past its usable term. Shelf life of this product is limited to six months after the date of manufacture. Carefully adhere to the expiration or manufacture date printed on the box.
- Keep primers and adhesive in a cool, dry place. Ideally, they should be stored in a refrigerator.
- Do not leave primers or adhesive cartridge unattended with their caps open or off.
- The vehicle should not be driven for at least 24 hours or until the urethane adhesive has completely cured. Curing time varies depending on temperature and humidities. The curing time will increase under lower temperatures and lower humidities.

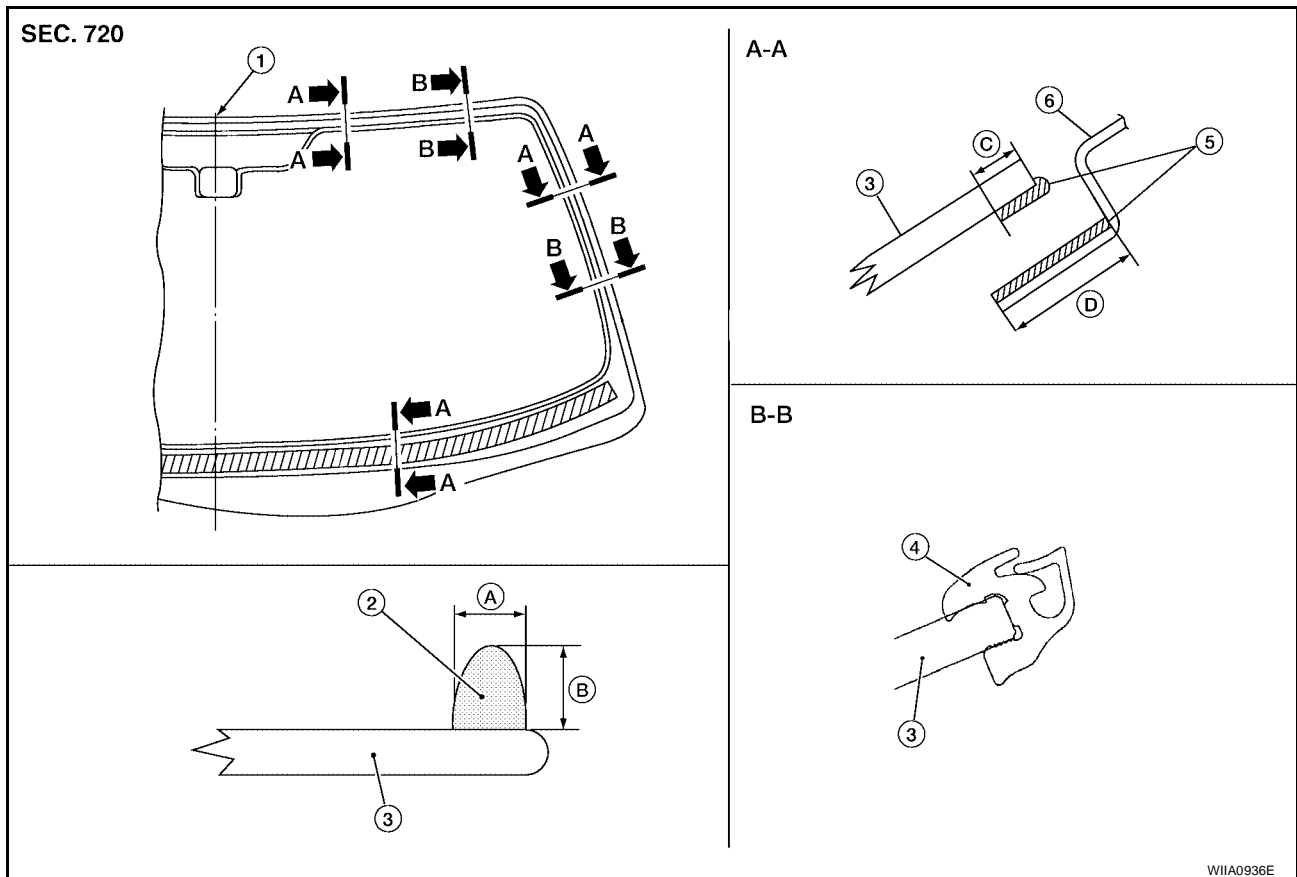

- | | | |
|----------------------|----------------------|---------------------|
| 1. Vehicle center | 2. Sealant | 3. Windshield glass |
| 4. Molding | 5. Primer portion | 6. Body panel |
| A. 7.0 mm (0.28 in) | B. 12.0 mm (0.47 in) | C. 15 mm (0.59 in) |
| D. 22.0 mm (0.87 in) | | |

WI1A0936E

Repairing Water Leaks for Windshield

Leaks can be repaired without removing and reinstalling glass. If water is leaking between the urethane adhesive material and body or glass, determine the extent of leakage. This can be done by applying water to the windshield area while pushing glass outward.

WINDSHIELD GLASS

To stop the leak, apply primer (if necessary) and then urethane adhesive to the leak point.

A

B

C

D

E

F

G

H

GW

J

K

L

M

REAR WINDOW GLASS AND MOLDING

REAR WINDOW GLASS AND MOLDING

PF9:79712

Removal and Installation

EIS009YN

SEC. 900

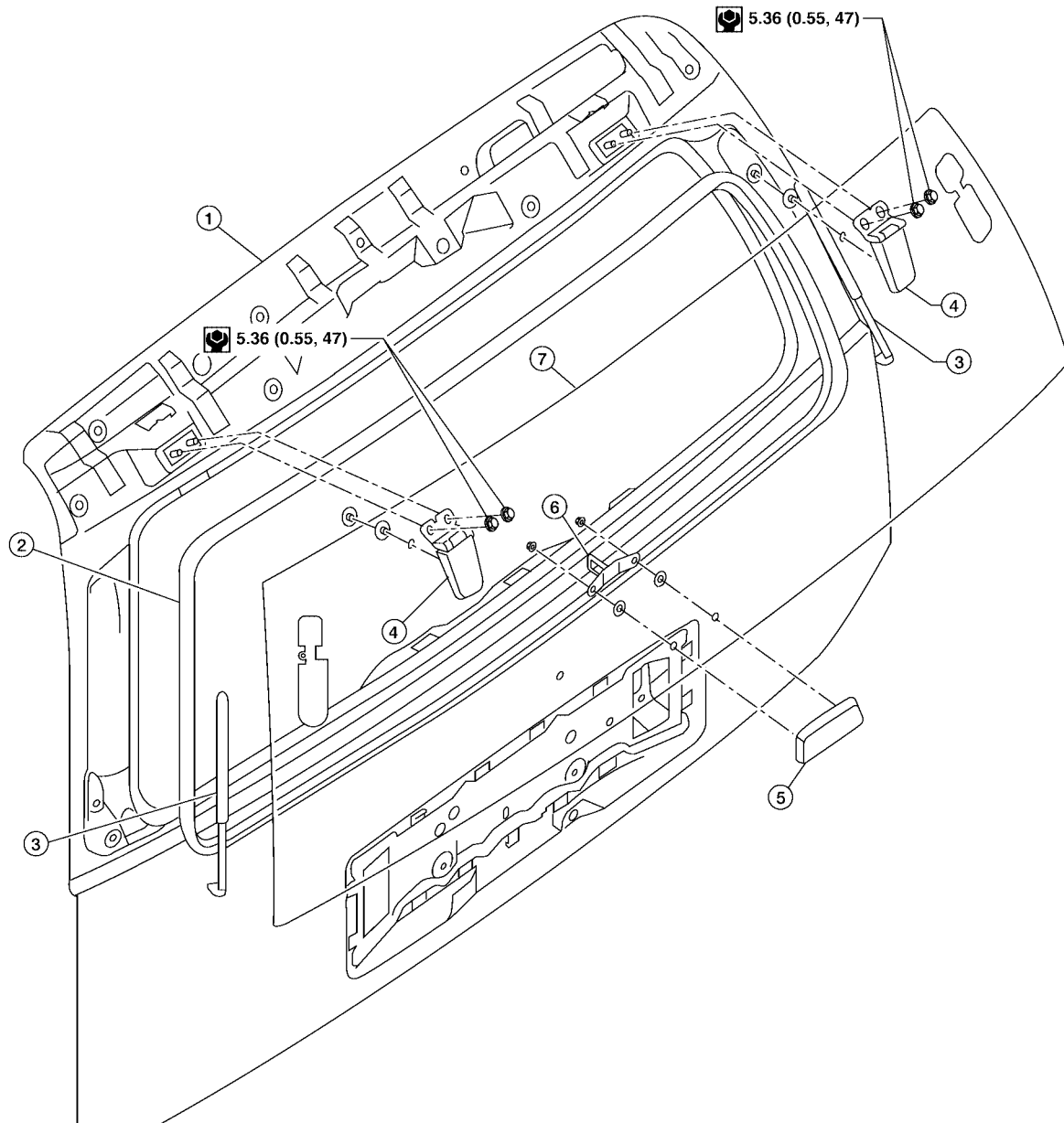

- | | | |
|--------------------------------------|-----------------------------|------------------------------------|
| 1. Back door assembly | 2. Weatherstrip | 3. Rear glass stay RH, LH |
| 4. Rear window hinge assembly RH, LH | 5. Rear window glass handle | 6. Rear window glass latch striker |
| 7. Rear glass assembly | | |

WIIA1010E

REMOVAL

1. Remove the rear spoiler. Refer to [EI-23, "REAR SPOILER"](#).
2. Disconnect the rear window defogger electrical connectors.
3. Remove the rear glass stays.
4. Remove the hinge nuts and the rear glass assembly.
5. Remove the striker and handle.

REAR WINDOW GLASS AND MOLDING

6. Remove the rear glass hinges.

INSTALLATION

Installation is in the reverse order of removal.

A

B

C

D

E

F

G

H

GW

J

K

L

M

POWER WINDOW SYSTEM

PF25401

EIS009YO

POWER WINDOW SYSTEM

Component Parts and Harness Connector Location

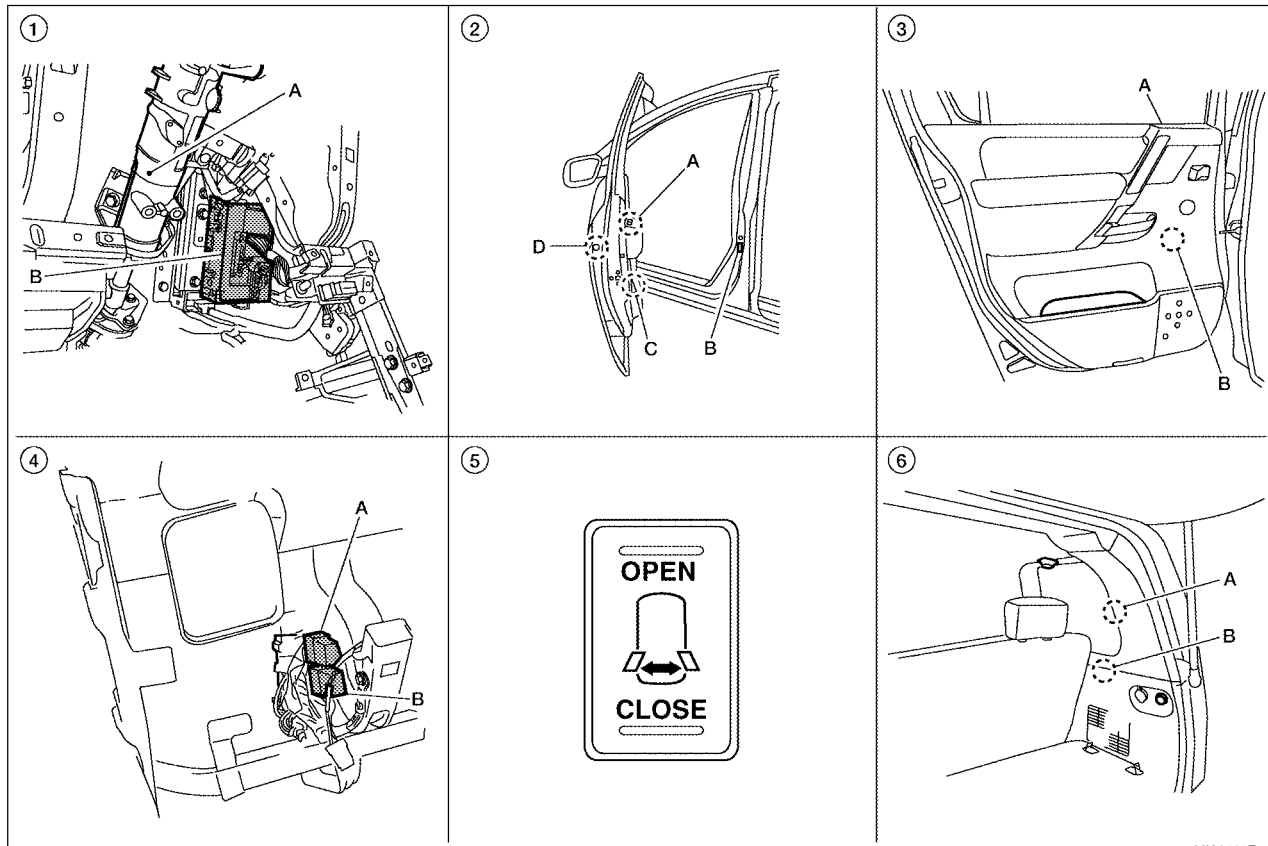

L1A2715E

- | | | |
|--|--|--|
| <p>1. A. Steering column
B. BCM M18, M19, M20 (view with instrument panel removed)</p> | <p>2. A. Main power window and door lock/unlock switch D7, D8
Power window and door lock/unlock switch RH D105
B. Front door switch LH B8, RH B108
C. Front power window motor LH D9, RH D104
D. Front door lock actuator LH (key cylinder switch)</p> | <p>3. A. Rear power window switch LH D203, RH D303
B. Rear power window motor LH D204, RH D304</p> |
| <p>4. A. Rear power vent window relay (CLOSE)
B. Rear power vent window relay (OPEN)</p> | <p>5. Rear power vent window switch R103</p> | <p>6. A. Rear power vent window motor LH B52, RH B150
B. Condenser-3 B119
Condenser-4 B120</p> |

System Description

EIS009YP

Power is supplied at all times

- from 50A fusible link (letter f , located in the fuse and fusible link box)
- to BCM terminal 70
- through BCM terminal 69
- to main power window and door lock/unlock switch terminal 19
- to power window and door lock/unlock switch RH terminal 10.

With ignition switch in ON or START position, power is supplied

- through 10A fuse (No. 59, located in the fuse and relay box)
- to BCM terminal 38
- through BCM terminal 68
- to main power window and door lock/unlock switch terminal 10.

POWER WINDOW SYSTEM

With ignition switch in ON or START position, ground is supplied

- to BCM terminal 67
- to main power window and door lock/unlock switch terminal 17
- to power window and door lock/unlock switch RH terminal 11
- through body grounds M57, M61 and M79.

MANUAL OPERATION

Front Door LH

WINDOW UP

When the front LH switch in the main power window and door lock/unlock switch is pressed in the up position, power is supplied

- through main power window and door lock/unlock switch terminal 8
- to front power window motor LH terminal 2.

Ground is supplied

- through main power window and door lock/unlock switch terminal 11
- to front power window motor LH terminal 1.

Then, the motor raises the window until the switch is released.

WINDOW DOWN

When the front LH switch in the main power window and door lock/unlock switch is pressed in the down position, power is supplied

- through main power window and door lock/unlock switch terminal 11
- to front power window motor LH terminal 1.

Ground is supplied

- through main power window and door lock/unlock switch terminal 8
- to front power window motor LH terminal 2.

Then, the motor lowers the window until the switch is released.

Front Door RH

POWER WINDOW AND DOOR LOCK/UNLOCK SWITCH RH OPERATION

WINDOW UP

When the power window and door lock/unlock switch RH is pressed in the up position, power is supplied

- through power window and door lock/unlock switch RH terminal 8
- to front power window motor RH terminal 2.

Ground is supplied

- through power window and door lock/unlock switch RH terminal 9
- to front power window motor RH terminal 1.

Then, the motor raises the window until the switch is released.

WINDOW DOWN

When the power window and door lock/unlock switch RH is pressed in the down position, power is supplied

- through power window and door lock/unlock switch RH terminal 9
- to front power window motor RH terminal 1.

Ground is supplied

- through power window and door lock/unlock switch RH terminal 8
- to front power window motor RH terminal 2.

Then, the motor lowers the window until the switch is released.

MAIN POWER WINDOW AND DOOR LOCK/UNLOCK SWITCH OPERATION

Signal is sent

- through main power window and door lock/unlock switch terminal 14
- to power window and door lock/unlock switch RH terminal 16.

The operation of power window after receiving the signal is the same as operating the power window with power window and door lock/unlock switch RH.

A

B

C

D

E

F

G

H

GW

J

K

L

M

POWER WINDOW SYSTEM

Rear Door (LH or RH)

REAR POWER WINDOW SWITCH LH OR RH OPERATION

WINDOW UP

When the rear power window switch LH or RH is pressed in the up position, power is supplied

- through rear power window switch LH or RH terminal 4
- to rear power window motor LH or RH terminal 2.

Ground is supplied

- through rear power window switch LH or RH terminal 5
- to rear power window motor LH or RH terminal 1.

Then, the motor raises the window until the switch is released.

WINDOW DOWN

When the rear power window switch LH or RH is pressed in the down position, power is supplied

- through rear power window switch LH or RH terminal 5
- to rear power window motor LH or RH terminal 1.

Ground is supplied

- through rear power window switch LH or RH terminal 4
- to rear power window motor LH or RH terminal 2.

Then, the motor lowers the window until the switch is released.

MAIN POWER WINDOW AND DOOR LOCK/UNLOCK SWITCH OPERATION

WINDOW UP

When the main power window and door lock/unlock switch (rear LH) is pressed in the up position, power is supplied

- through main power window and door lock/unlock switch terminal 3
- to rear power window switch LH terminal 3
- through rear power window switch LH terminal 4
- to rear power window motor LH terminal 2.

Ground is supplied

- through main power window and door lock/unlock switch terminal 1
- to rear power window switch LH terminal 2
- through rear power window switch LH terminal 5
- to rear power window motor LH terminal 1.

Then, the motor raises the window until the switch is released.

When the main power window and door lock/unlock switch (rear RH) is pressed in the up position, power is supplied

- through main power window and door lock/unlock switch terminal 5
- to rear power window switch RH terminal 3
- through rear power window switch RH terminal 4
- to rear power window motor RH terminal 2.

Ground is supplied

- through main power window and door lock/unlock switch terminal 7
- to rear power window motor RH terminal 2
- through rear power window switch RH terminal 5
- to rear power window switch RH terminal 1.

Then, the motor raises the window until the switch is released.

WINDOW DOWN

When the main power window and door lock/unlock switch (rear LH) is pressed in the down position, power is supplied

- through main power window and door lock/unlock switch terminal 1
- to rear power window switch LH terminal 2
- through rear power window switch LH terminal 5
- to rear power window motor LH terminal 1.

POWER WINDOW SYSTEM

Ground is supplied

- to main power window and door lock/unlock switch terminal 3
- through rear power window switch LH terminal 4
- through rear power window switch LH terminal 3
- to rear power window motor LH terminal 1.

Then, the motor raises the window until the switch is released.

When the main power window and door lock/unlock switch (rear RH) is pressed in the down position, power is supplied

- through main power window and door lock/unlock switch terminal 7
- to rear power window switch RH terminal 2
- through rear power window switch RH terminal 5
- to rear power window motor RH terminal 1.

Ground is supplied

- through main power window and door lock/unlock switch terminal 5
- to rear power window switch RH terminal 3
- through rear power window switch RH terminal 4
- to rear power window motor RH terminal 2.

Then, the motor raises the window until the switch is released.

VENT WINDOW CLOSE

When the rear power vent window switch is pressed in the close position, power is supplied

- to rear power vent window relay (CLOSE) terminal 5
- through rear power vent window relay (CLOSE) terminal 3
- to rear power vent window motors terminal 2.

Ground is supplied

- to rear power vent window relay (OPEN) terminal 4
- through rear power vent window relay (OPEN) terminal 3
- to rear power vent window motors terminal 1.

Then, the motors close the windows until the switch is released.

VENT WINDOW OPEN

When the rear power vent window switch is pressed in the open position, power is supplied

- to rear power vent window relay (OPEN) terminal 5
- through rear power vent window relay (OPEN) terminal 3
- to rear power vent window motors terminal 1.

Ground is supplied

- to rear power vent window relay (CLOSE) terminal 4
- through rear power vent window relay (CLOSE) terminal 3
- to rear power vent window motors terminal 2.

Then, the motors open the windows until the switch is released.

AUTO OPERATION

The power window AUTO feature enables the driver to open or close the window without holding the window switch in the down or up position.

POWER WINDOW SERIAL LINK

Main power window and door lock/unlock switch, power window and door lock/unlock switch RH, and BCM transmit and receive the signal by power window serial link.

The signal is transmitted from BCM to main power window and door lock/unlock switch and power window and door lock/unlock switch RH

- Keyless power window down signal.

The signal is transmitted from main power window and door lock/unlock switch to power window and door lock/unlock switch RH

- Front door window RH operation signal.

A

B

C

D

E

F

G

H

GW

J

K

L

M

POWER WINDOW SYSTEM

- Power window control by front door lock assembly LH (key cylinder switch) signal.
- Power window lock signal.
- Retained power operation signal.

POWER WINDOW LOCK

The power window lock is designed to lock operation of all windows except for front door window LH. When in the lock position, the power window lock signal is transmitted to power window and door lock/unlock switch RH by power window serial link. This prevents the power window motor from operating.

RETAINED POWER OPERATION

When the ignition switch is turned to the OFF position from ON or START position, power is supplied for 45 seconds

- to main power window and door lock/unlock switch terminal 10
- from BCM terminal 68.

When power and ground are supplied, the BCM continues to be energized, and the power window can be operated.

The retained power operation is canceled when the front LH or front RH door is opened.

retained power operation period can be changed by CONSULT-II. Refer to [GW-33, "CONSULT-II Function \(BCM\)"](#) .

ANTI-PINCH SYSTEM

Main power window and door lock/unlock switch and power window and door lock/unlock switch RH monitor the power window motor operation and the power window position (full closed or other) for front LH and front RH power window by the signals from encoder and limit switch in front power window motor LH and RH.

When main power window and door lock/unlock switch or power window and door lock/unlock switch RH detects interruption during the following close operation,

- automatic close operation when ignition switch is in the ON position
- automatic close operation during retained power operation

Main power window and door lock/unlock switch or power window and door lock/unlock switch RH controls each front power window motor for open and the power window will be lowered about 150 mm (5.91 in).

POWER WINDOW CONTROL BY THE FRONT DOOR LOCK ASSEMBLY LH (KEY CYLINDER SWITCH)

When ignition key switch is OFF, front power window LH and RH can be opened or closed by turning the front door lock assembly LH (key cylinder switch) to the UNLOCK/LOCK position for more than 1 second.

- Front power windows can be opened as the front door lock assembly LH (key cylinder switch) is kept fully turning to the UNLOCK position.
- Front power windows can be closed as the front door lock assembly LH (key cylinder switch) is kept fully turning to the LOCK position.
- While performing open/close operation for the windows, power window is stopped when the front door lock assembly LH (key cylinder switch) is placed in the NEUTRAL position.
- When the ignition switch is turned ON while the power window opening operation is performed, the power window opening stops.

CAN Communication System Description

EIS009YQ

Refer to [LAN-4, "SYSTEM DESCRIPTION"](#) .

POWER WINDOW SYSTEM

Schematic

EIS009YR

(PV) WITH REAR POWER VENT WINDOWS

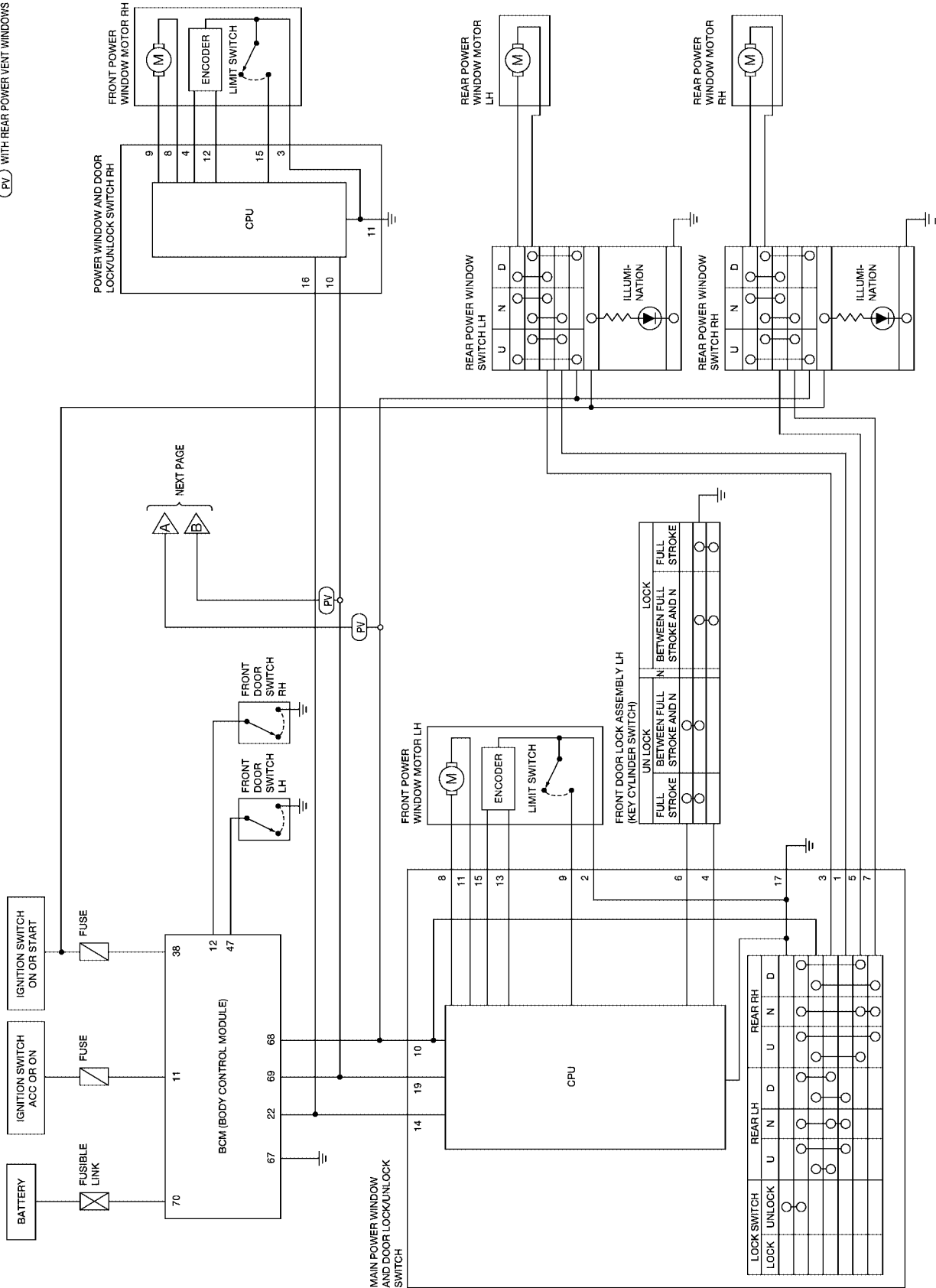

A
B
C
D
E
F
G
H
J
K
L
M

GW

WIWA2006E

POWER WINDOW SYSTEM

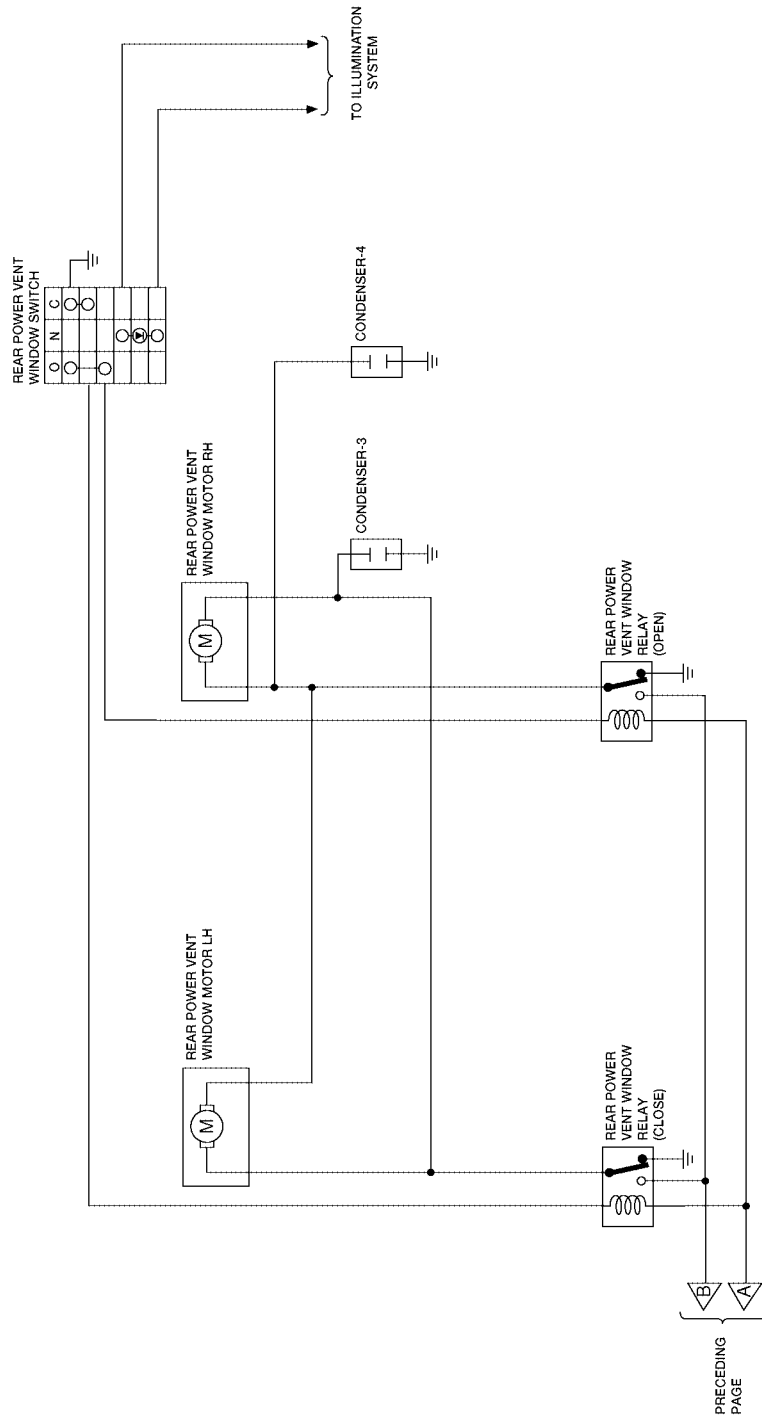

LIWA0370E

POWER WINDOW SYSTEM

Wiring Diagram — WINDOW —

EIS009YS

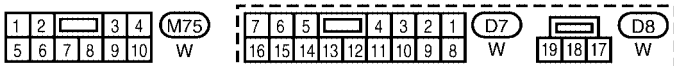
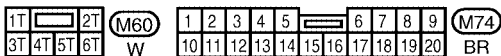
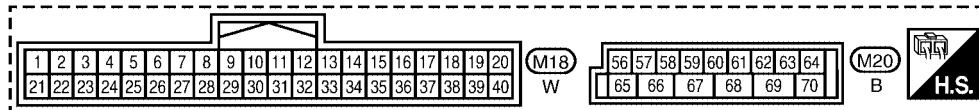
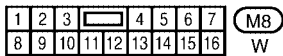
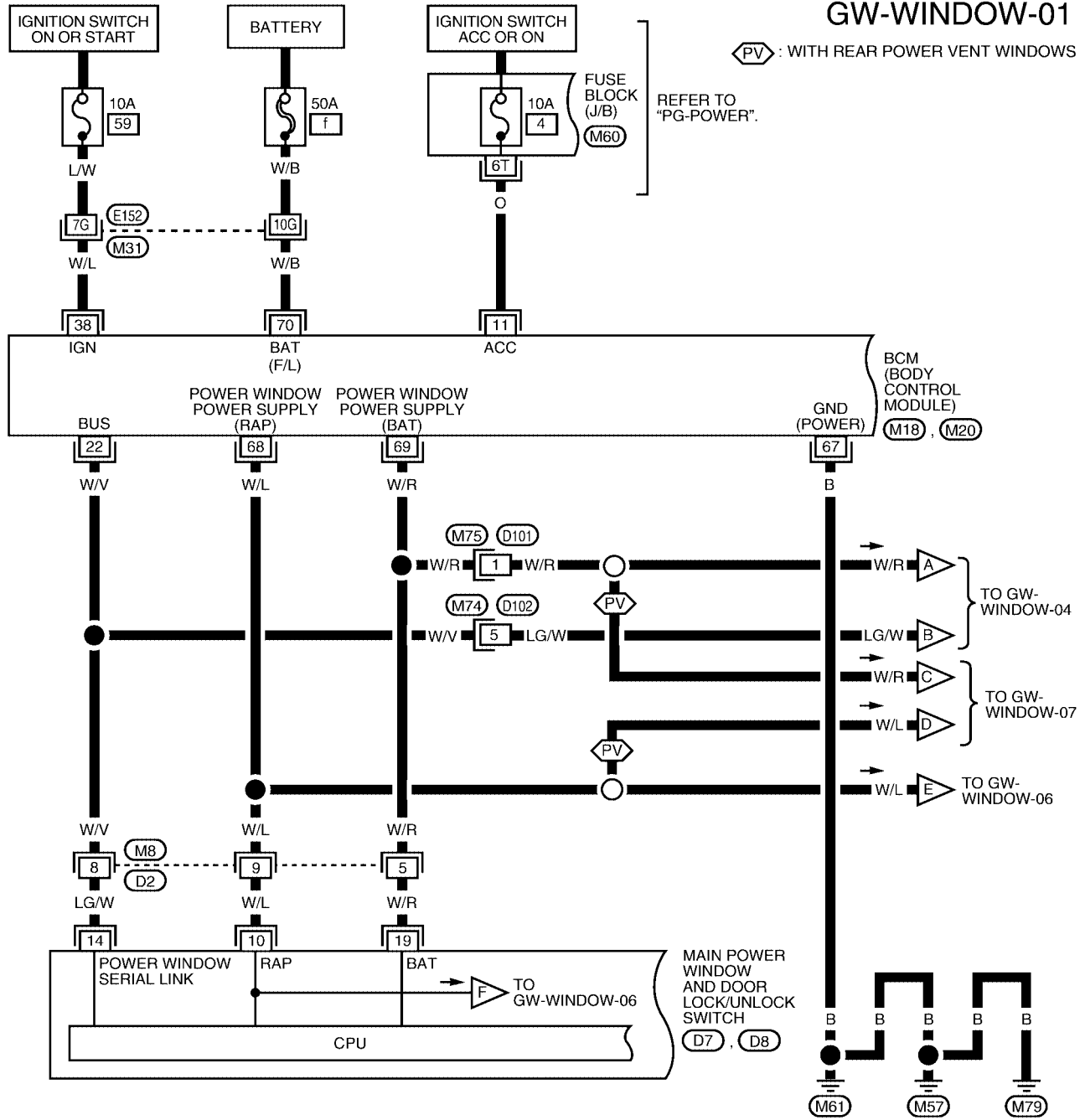

REFER TO THE FOLLOWING.
 (M31) - SUPER MULTIPLE JUNCTION (SMJ)

WIWA2026E

POWER WINDOW SYSTEM

GW-WINDOW-02

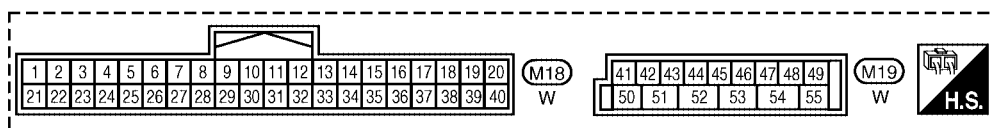
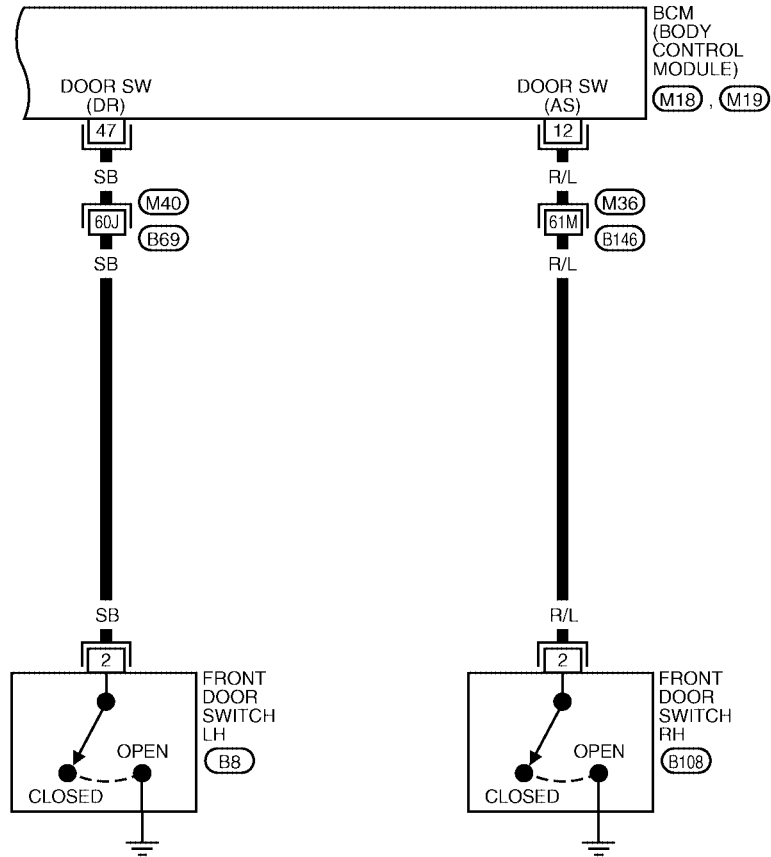

REFER TO THE FOLLOWING.
 (M36), (M40) - SUPER
 MULTIPLE JUNCTION (SMJ)

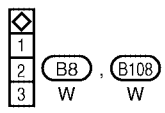

LIWA0372E

POWER WINDOW SYSTEM

GW-WINDOW-03

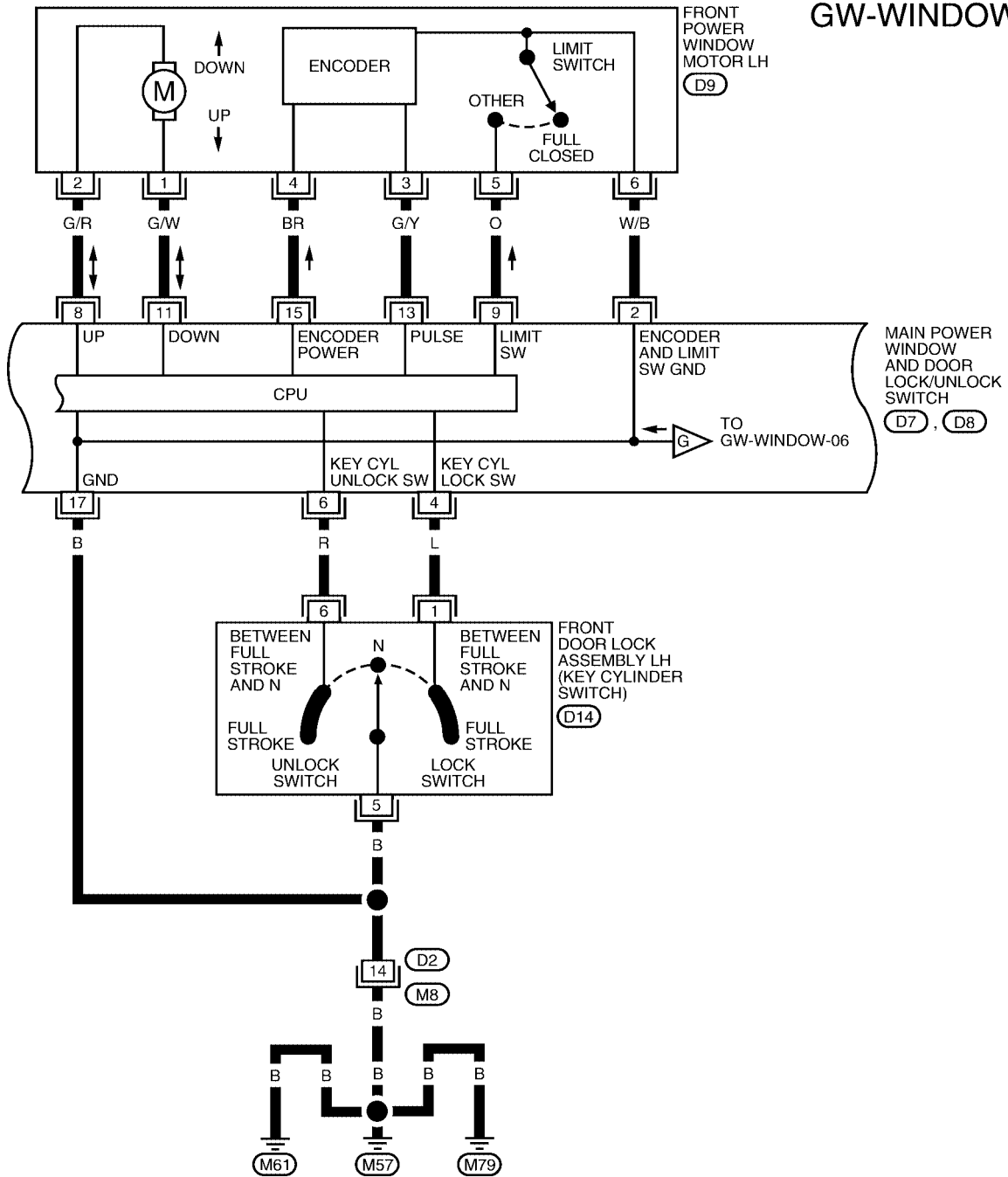

A
B
C
D
E
F
G
H
J
K
L
M

GW

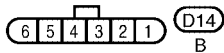
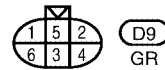
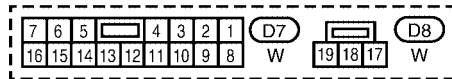
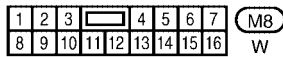

W1WA0726E

POWER WINDOW SYSTEM

GW-WINDOW-04

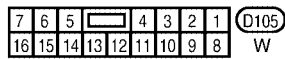
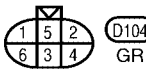
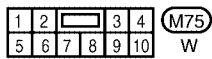
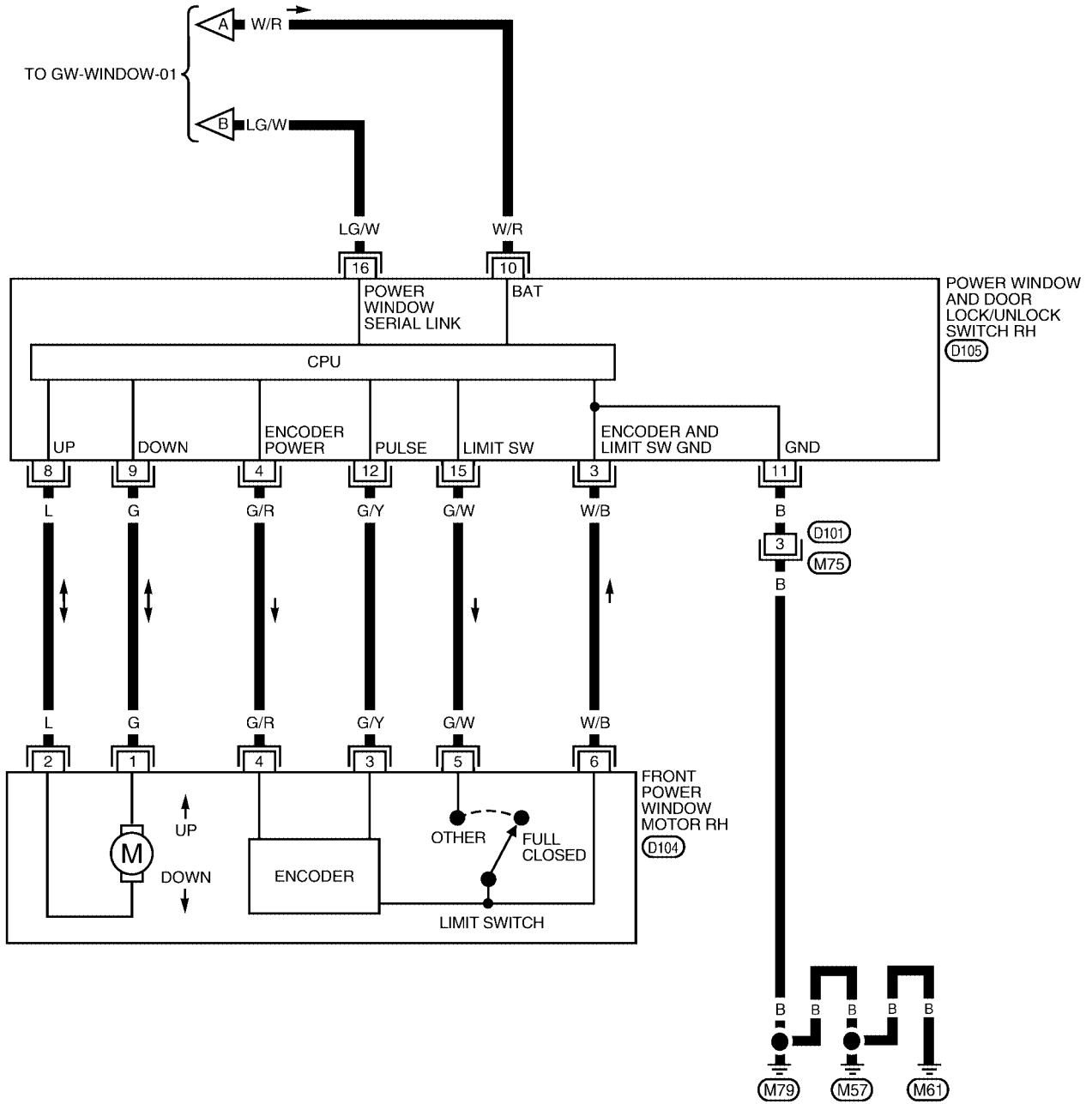

WIVA2007E

POWER WINDOW SYSTEM

GW-WINDOW-05

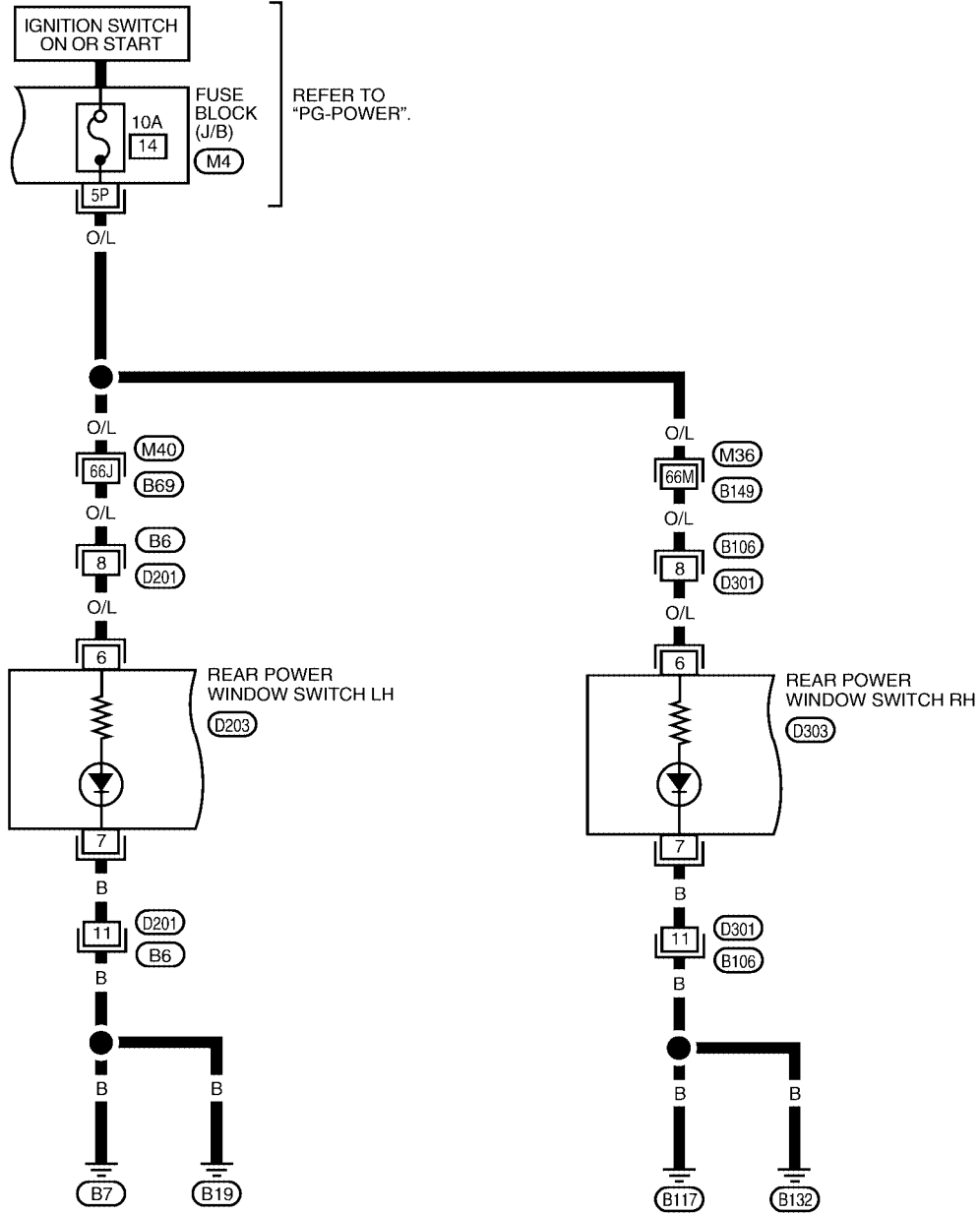

A
B
C
D
E
F
G
H
J
K
L
M

GW

1P	2P	3P	4P	5P	6P	7P	M4	6	7	8	D203	D303		
8P	9P	10P	11P	12P	13P	14P	W	1	5	4	3	2	W	W

1	2	3	4	5	6	7	8	9	10	B6	B106
11	12	13	14	15	16	17	18	W	W		

REFER TO THE FOLLOWING.
 (M36), (M40) - SUPER
 MULTIPLE JUNCTION (SMJ)

W1WA1405E

POWER WINDOW SYSTEM

GW-WINDOW-06

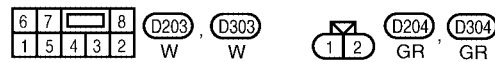
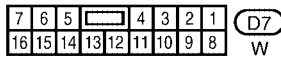
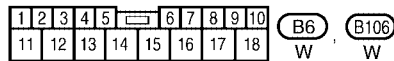
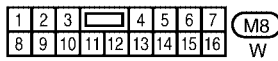
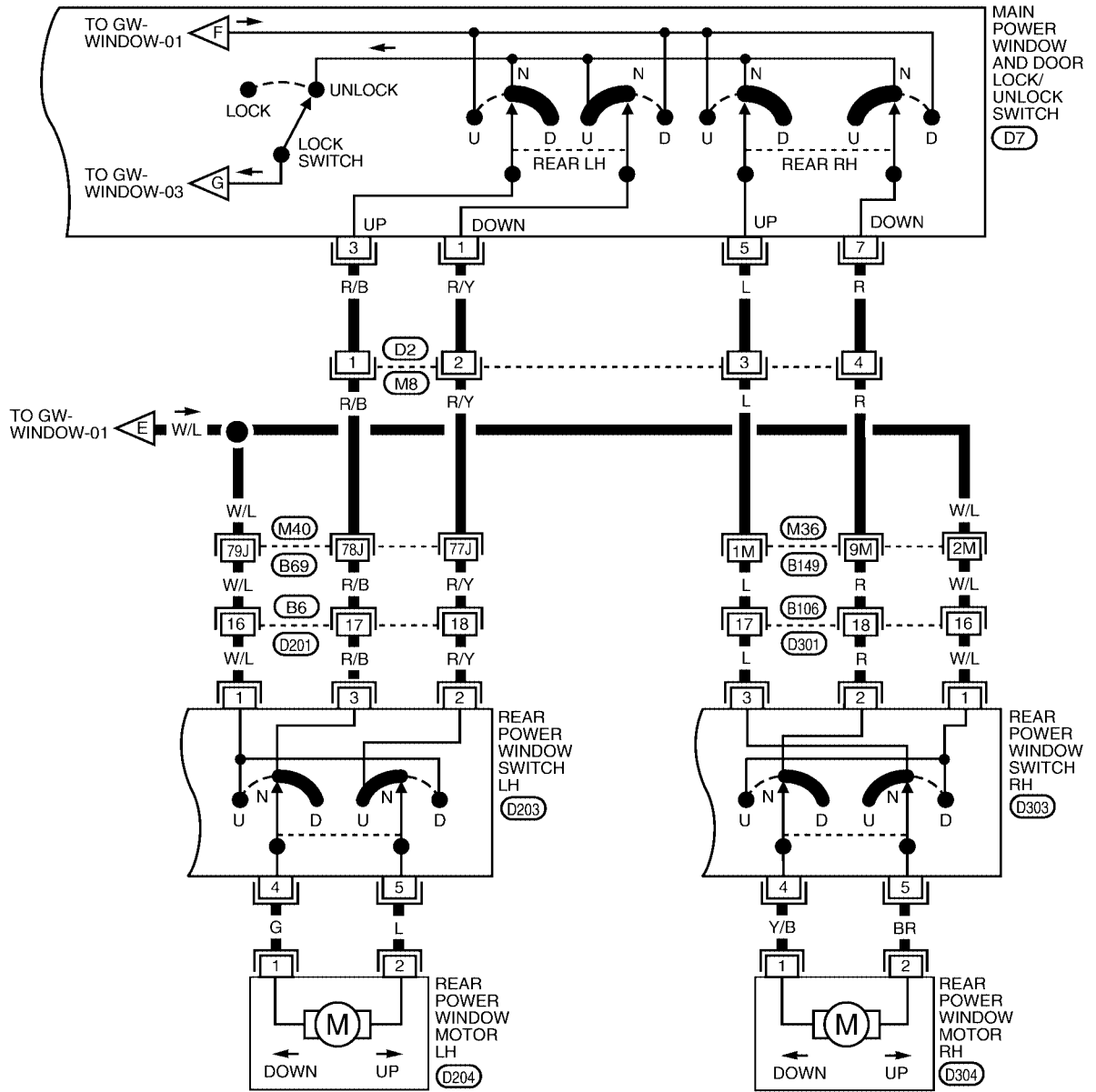

REFER TO THE FOLLOWING.
 (M36), (M40) - SUPER MULTIPLE JUNCTION (SMJ)

WIIWA2008E

POWER WINDOW SYSTEM

GW-WINDOW-07

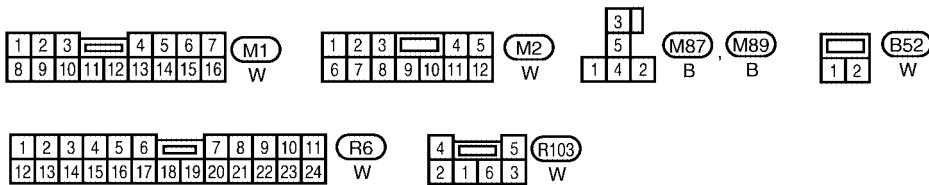
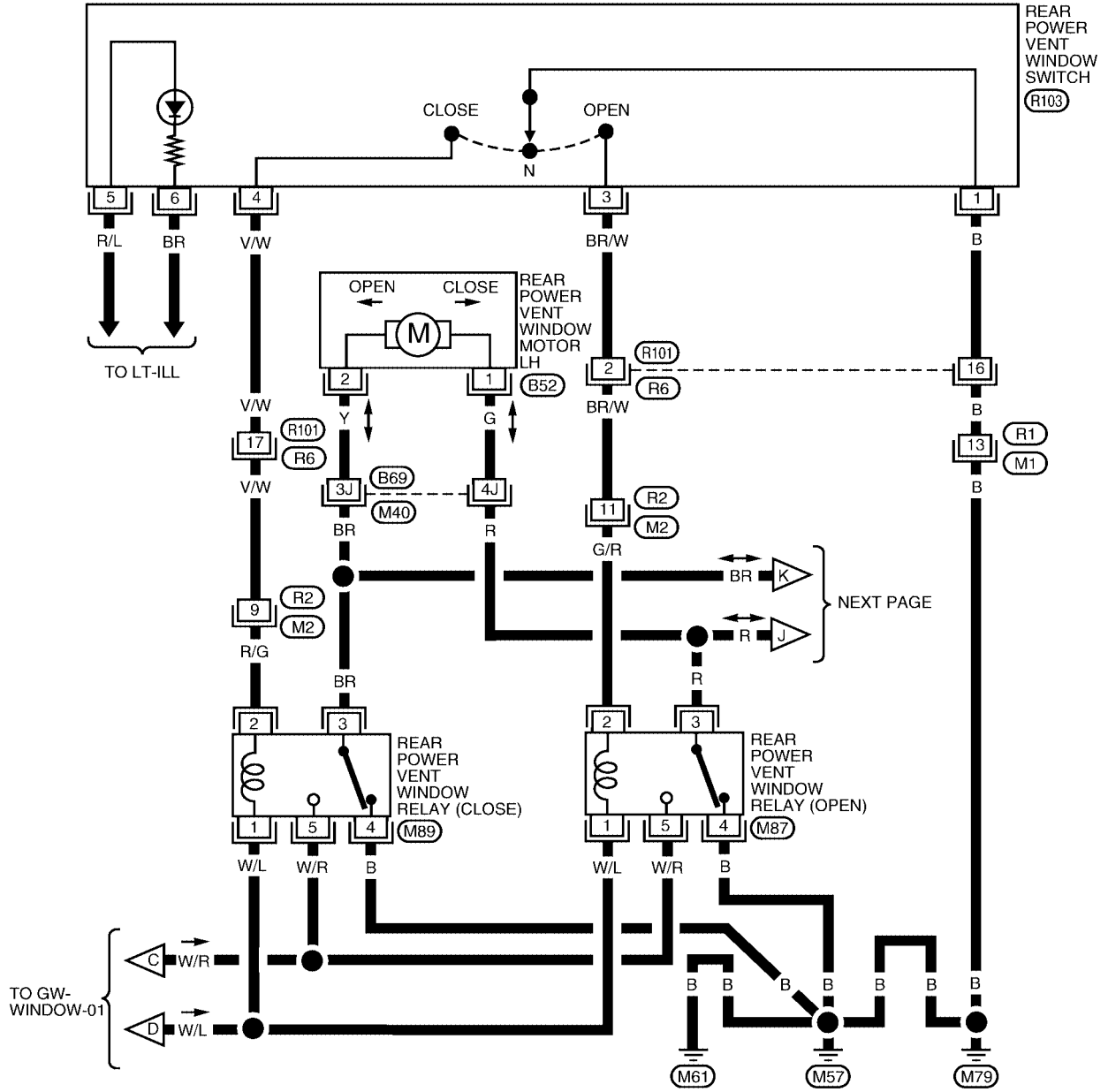

REFER TO THE FOLLOWING.
 (M40) - SUPER MULTIPLE JUNCTION (SMJ)

W1WA1172E

POWER WINDOW SYSTEM

GW-WINDOW-08

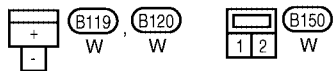
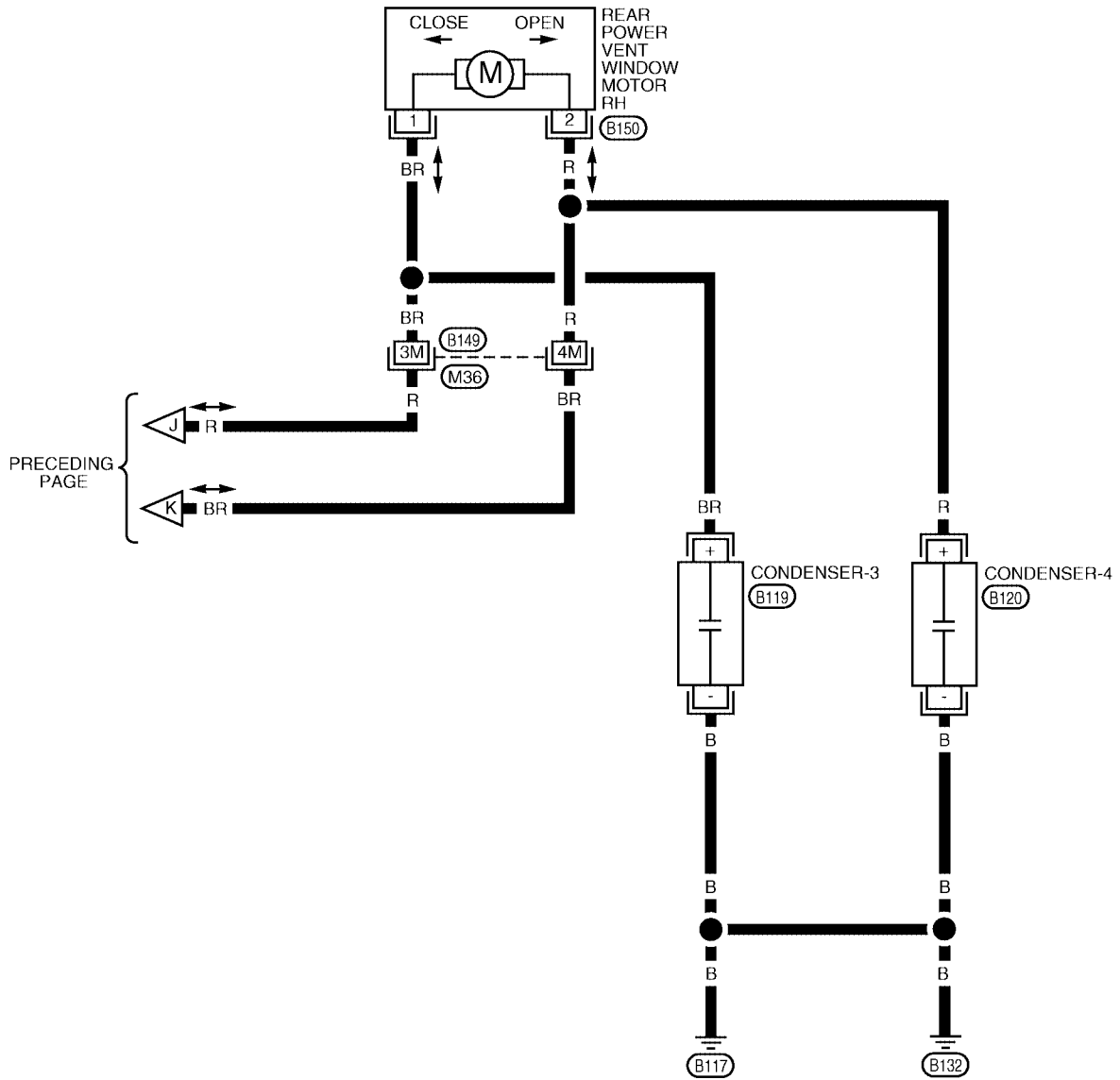

REFER TO THE FOLLOWING.
 (M36) - SUPER MULTIPLE
 JUNCTION (SMJ)

W1WA1173E

POWER WINDOW SYSTEM

Main Power Window and Door Lock/Unlock Switch Harness Connector Terminal Layout

EIS0099V

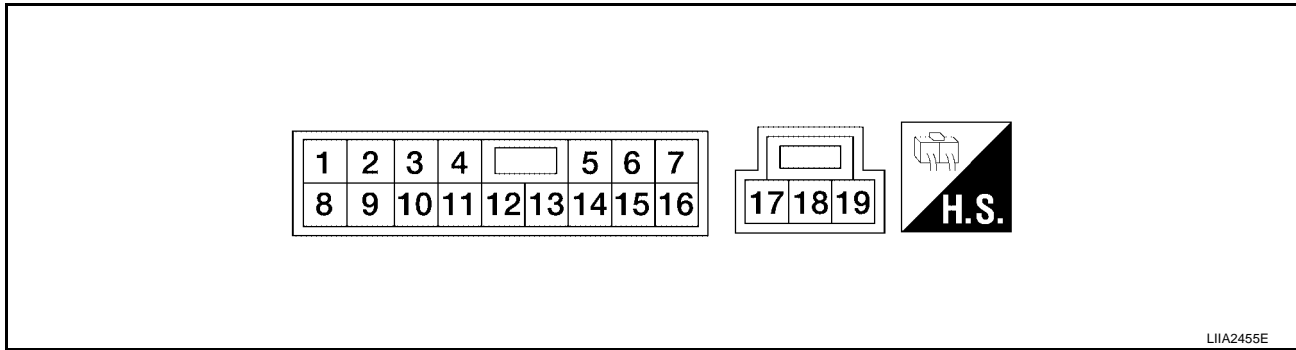

LIA2455E

Terminals and Reference Values for Main Power Window and Door Lock/Unlock Switch

EIS009YT

Terminal	Wire Color	Item	Condition	Voltage (V) (Approx.)
1	R/Y	Rear power window LH DOWN signal	When rear LH switch in main power window and door lock/unlock switch is operated DOWN	Battery voltage
2	W/B	Limit switch and encoder ground	—	0
3	R/B	Rear power window LH UP signal	When rear LH switch in main power window and door lock/unlock switch is operated UP	Battery voltage
4	L	Front door lock assembly LH (key cylinder switch) unlock signal	Key position (Neutral → Unlocked)	5 → 0
5	L	Rear power window RH UP signal	When rear RH switch in main power window and door lock/unlock switch is operated UP	Battery voltage
6	R	Front door lock assembly LH (key cylinder switch) lock signal	Key position (Neutral → Locked)	5 → 0
7	R	Rear power window RH DOWN signal	When rear RH switch in main power window and door lock/unlock switch is operated DOWN	Battery voltage
8	G/R	Front power window motor LH UP signal	When front power window motor LH is operated UP	Battery voltage
9	O	Limit switch signal	Front window LH is between fully-open and just before fully-closed position (ON)	0
			Front window LH is between just before fully-closed position and fully-closed position (OFF)	5
10	W/L	RAP signal	When ignition switch ON	Battery voltage
			Within 45 seconds after ignition switch is turned to OFF	Battery voltage
			More than 45 seconds after ignition switch is turned to OFF	0
			When front door LH or RH open or power window timer operates	0
11	G/W	Front power window motor LH DOWN signal	When front power window motor LH is operated DOWN	Battery voltage

POWER WINDOW SYSTEM

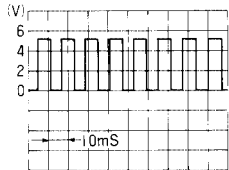
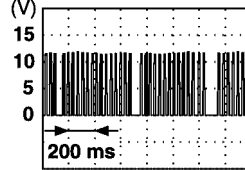
Terminal	Wire Color	Item	Condition	Voltage (V) (Approx.)
13	G/Y	Encoder pulse signal	When front power window motor LH operates	 OCC3383D
14	LG/W	Power window serial link	When ignition switch ON or power window timer operates	 PIIA2344J
15	BR	Encoder power supply	When ignition switch ON or power window timer operates	10
17	B	Ground	—	0
19	W/R	Battery power supply	—	Battery voltage

Power Window and Door Lock/Unlock Switch RH Harness Connector Terminal Layout

EIS0099W

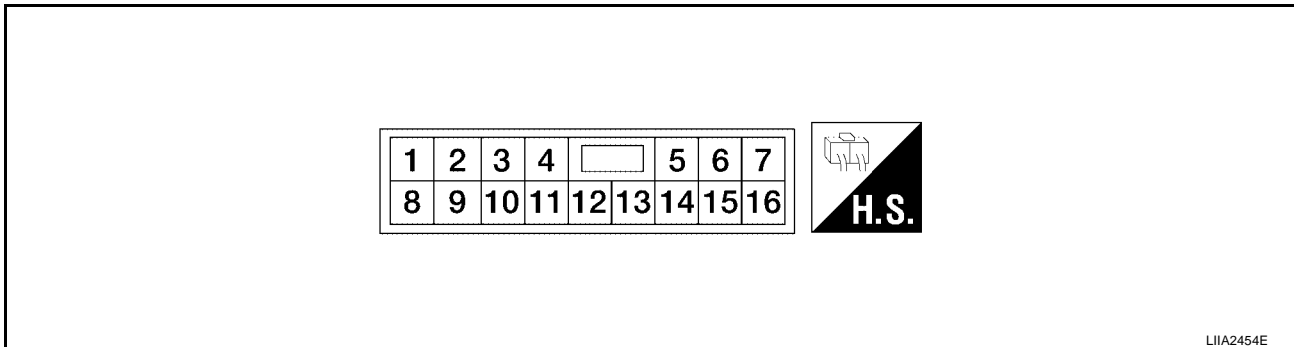

Terminals and Reference Values for Power Window and Door Lock/Unlock Switch RH

EIS0099YU

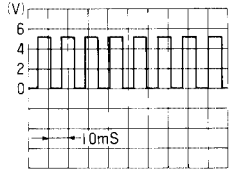
Terminal	Wire Color	Item	Condition	Voltage (V) (Approx.)
3	W/B	Limit switch and encoder ground	—	0
4	G/R	Encoder power supply	When ignition switch ON or power window timer operates	10
8	L	Front power window motor RH UP signal	When front power window motor RH is operated UP	Battery voltage
9	G	Front power window motor RH DOWN signal	When front power window motor RH is operated DOWN	Battery voltage
10	W/R	Battery power supply	—	Battery voltage
11	B	Ground	—	0
12	G/Y	Encoder pulse signal	When front power window motor RH operates	 OCC3383D

POWER WINDOW SYSTEM

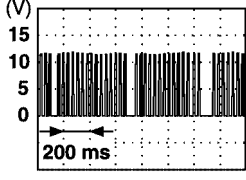
Terminal	Wire Color	Item	Condition	Voltage (V) (Approx.)
15	G/W	Limit switch signal	Front window RH is between fully-open and just before fully-closed position (ON)	0
			Front window RH is between just before fully-closed position and fully-closed position (OFF)	5
16	LG/W	Power window serial link	When ignition switch is ON or power window timer operating	 PIIA2344J

Terminals and Reference Values for BCM

EIS009YV

Refer to [BCS-12, "Terminals and Reference Values for BCM"](#) .

Work Flow

EIS009YW

1. Check the symptom and customer's requests.
2. Understand the outline of system. Refer to [GW-16, "System Description"](#) .
3. According to the trouble diagnosis chart, repair or replace the cause of the malfunction. Refer to [GW-34, "Trouble Diagnoses Symptom Chart"](#) .
4. Does power window system operate normally? Yes, GO TO 5, If No, GO TO 3.
5. Inspection End.

CONSULT-II Function (BCM)

EIS009YX

CONSULT-II can display each diagnostic item using the diagnostic test modes shown following.

BCM diagnostic test item	Diagnostic mode	Content
Inspection by part	WORK SUPPORT	Supports inspections and adjustments. Commands are transmitted to the BCM for setting the status suitable for required operation, input/output signals are received from the BCM and received data is displayed.
	DATA MONITOR	Displays BCM input/output data in real time.
	ACTIVE TEST	Operation of electrical loads can be checked by sending drive signal to them.
	SELF-DIAG RESULTS	Displays BCM self-diagnosis results.
	CAN DIAG SUPPORT MNTR	The results of transmit/receive diagnosis of CAN communication can be read.
	ECU PART NUMBER	BCM part number can be read.
	CONFIGURATION	Performs BCM configuration read/write functions.

CONSULT-II START PROCEDURE

Refer to [GI-38, "CONSULT-II Start Procedure"](#) .

ACTIVE TEST

Test Item	Description
RETAINED PWR	<p>This test is able to supply RAP signal (power) from BCM (body control module) to power window system and power sunroof system (if equipped). Those systems can be operated when turning on "RETAINED PWR" on CONSULT-II screen even if the ignition switch is turned OFF.</p> <p>NOTE: During this test, CONSULT-II can be operated with ignition switch in OFF position. "RETAINED PWR" should be turned "ON" or "OFF" on CONSULT-II screen when ignition switch is ON. Then turn ignition switch OFF to check retained power operation. CONSULT-II might be stuck if "RETAINED PWR" is turned "ON" or "OFF" on CONSULT-II screen when ignition switch is OFF.</p>

POWER WINDOW SYSTEM

WORK SUPPORT

Work item	Description
RETAINED PWR	RAP signal's power supply period can be changed by mode setting. Selects RAP signal's power supply period between three steps <ul style="list-style-type: none"> ● MODE1 (45 sec.) / MODE2 (OFF) / MODE3 (2 min.).

DATA MONITOR

Work item	Description
IGN ON SW	Indicates (ON/OFF) condition of ignition switch
DOOR SW-DR	Indicates (ON/OFF) condition of front door switch driver side
DOOR SW-AS	Indicates (ON/OFF) condition of front door switch passenger side

Trouble Diagnoses Symptom Chart

EIS009YY

Check that other systems using the signal of the following systems operate normally.

Symptom	Repair order	Refer to page
None of the power windows can be operated using any switch	1. BCM power supply and ground circuit check	BCS-17
	2. Main power window and door lock/unlock power supply and ground circuit check	GW-35
	3. Power window serial link check	GW-49
	4. Replace main power window and door lock/unlock switch	EI-28
Front power window LH alone does not operate	1. Front power window motor LH circuit check	GW-38
	2. Replace main power window and door lock/unlock switch	EI-28
Front power window RH alone does not operate	1. Power window and door lock/unlock switch RH power supply and ground circuit check	GW-36
	2. Power window serial link check	GW-49
	3. Front power window motor RH circuit check	GW-38
	4. Replace BCM	BCS-26
Rear power window LH alone does not operate	1. Rear power window motor LH circuit check	GW-51
Rear power window RH alone does not operate	1. Rear power window motor RH circuit check	GW-52
Rear power vent windows do not operate	1. Rear power vent window switch circuit check	GW-53
Rear power vent window LH alone does not operate	1. Rear power vent window motor LH circuit check	GW-54
Rear power vent window RH alone does not operate	1. Rear power vent window motor RH circuit check	GW-54
Rear power vent windows do not open	1. Rear power vent window relay (OPEN) check	GW-55
Rear power vent windows do not close	1. Rear power vent window relay (CLOSE) check	GW-56
Anti-pinch system does not operate normally (Front LH)	1. Door window sliding part malfunction <ul style="list-style-type: none"> ● A foreign material adheres to window glass or glass run rubber. ● Glass run rubber wear or deformation. ● Sash is tilted too much, or not enough. 	—
	2. Limit switch adjusting	GW-59
	3. Limit switch circuit check LH	GW-39
	4. Encoder circuit check LH	GW-42

POWER WINDOW SYSTEM

Symptom	Repair order	Refer to page
Anti-pinch system does not operate normally (Front RH)	1. Door window sliding part malfunction <ul style="list-style-type: none"> ● A foreign material adheres to window glass or glass run rubber. ● Glass run rubber wear or deformation. ● Sash is tilted too much, or not enough. 	—
	2. Limit switch adjusting	GW-59
	3. Limit switch circuit check RH	GW-41
	4. Encoder circuit check RH	GW-44
Power window retained power operation does not operate properly	1. Check the retained power operation mode setting.	GW-34
	2. Door switch check	GW-46
	3. Replace BCM.	BCS-26
Power window does not operate by front door lock assembly LH (key cylinder switch)	1. Front door lock assembly LH (key cylinder switch check	GW-47
	2. Replace main power window and door lock/unlock switch	EI-28
Power window lock switch does not function	1. Power window lock switch circuit check	GW-49

BCM Power Supply and Ground Circuit Check

EIS009YZ

Refer to [BCS-17, "BCM Power Supply and Ground Circuit Check"](#) .

Main Power Window and Door Lock/Unlock Switch Power Supply and Ground Circuit Check

EIS009Z0

1. CHECK POWER SUPPLY CIRCUIT

- Turn ignition switch ON.
- Check voltage between main power window and door lock/unlock switch connector D7 terminal 10, D8 terminal 19 and ground.

10 - Ground : Battery voltage
19 - Ground : Battery voltage

OK or NG

- OK >> GO TO 2.
 NG >> GO TO 3.

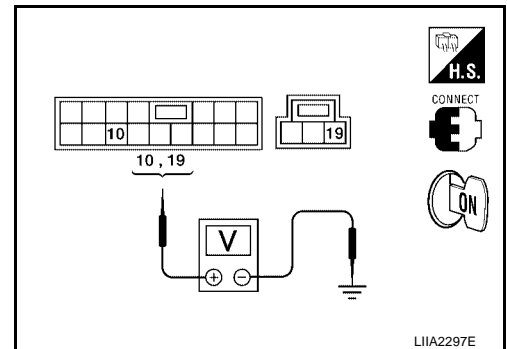

2. CHECK GROUND CIRCUIT

- Turn ignition switch OFF.
- Disconnect main power window and door lock/unlock switch.
- Check continuity between main power window and door lock/unlock switch connector D8 terminal 17 and ground.

17 - Ground : Continuity should exist.

OK or NG

- OK >> Power supply and ground circuit are OK.
 NG >> Repair or replace harness.

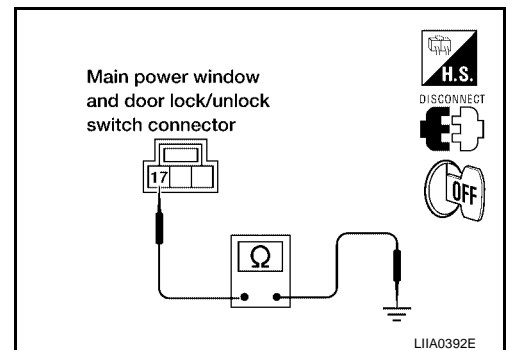

POWER WINDOW SYSTEM

3. CHECK MAIN POWER WINDOW AND DOOR LOCK/UNLOCK SWITCH POWER SUPPLY CIRCUIT

1. Turn ignition switch OFF.
2. Disconnect BCM and main power window and door lock/unlock switch.
3. Check continuity between BCM connector and main power window and door lock/unlock switch connectors.

Connector	Terminal	Connector	Terminal	Continuity
A		B		
BCM: M20	68	Main power window and door lock/unlock switch: D7	10	Yes
	69	Main power window and door lock/unlock switch: D8	19	Yes

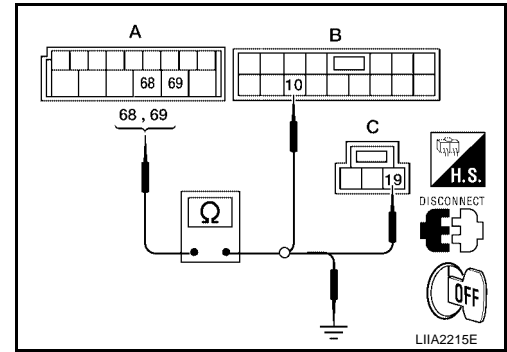

4. Check continuity between BCM and ground.

Connector	Terminal	Ground	Continuity
A			
BCM: M20	68	Ground	No
	69		No

OK or NG

- OK >> GO TO 4.
 NG >> Repair or replace harness.

4. CHECK BCM OUTPUT SIGNAL

1. Connect BCM.
2. Turn ignition switch ON.
3. Check voltage between BCM connector M20 terminal 68, 69 and ground.

68 - Ground : Battery voltage
69 - Ground : Battery voltage

OK or NG

- OK >> Check the condition of the harness and the connector.
 NG >> Replace BCM. Refer to [BCS-26, "Removal and Installation"](#) .

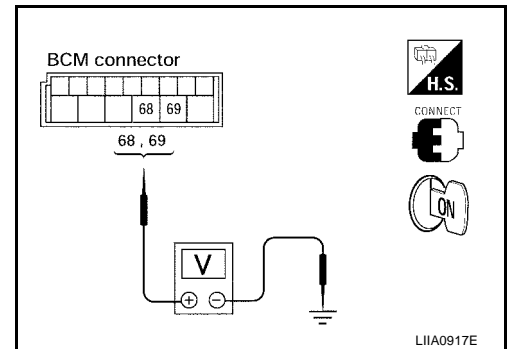

Power Window and Door Lock/Unlock Switch RH Power Supply and Ground Circuit Check

EIS009Z1

1. CHECK POWER SUPPLY CIRCUIT

1. Turn ignition switch ON.
2. Check voltage between power window and door lock/unlock switch RH connector D105 terminal 10 and ground.

10 - Ground : Battery voltage

OK or NG

- OK >> GO TO 2.
 NG >> GO TO 3.

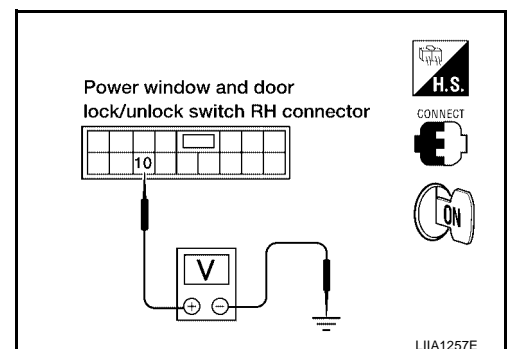

POWER WINDOW SYSTEM

2. CHECK GROUND CIRCUIT

1. Turn ignition switch OFF.
2. Disconnect power window and door lock/unlock switch RH.
3. Check continuity between power window and door lock/unlock switch RH connector D105 terminal 11 and ground.

11 - Ground : Continuity should exist.

OK or NG

- OK >> Power supply and ground circuit are OK.
NG >> Repair or replace harness.

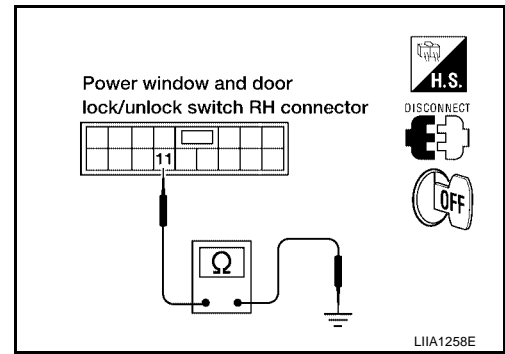

3. CHECK POWER WINDOW AND DOOR LOCK/UNLOCK SWITCH RH POWER SUPPLY CIRCUIT

1. Turn ignition switchn OFF.
2. Disconnect BCM.
3. Check continuity between BCM connector M20 (A) terminal 69 and power window and door lock/unlock switch RH connector D105 (B) terminal 10.

69 - 10 : Continuity should exist.

OK or NG

- OK >> GO TO 4.
NG >> Repair or replace harness.

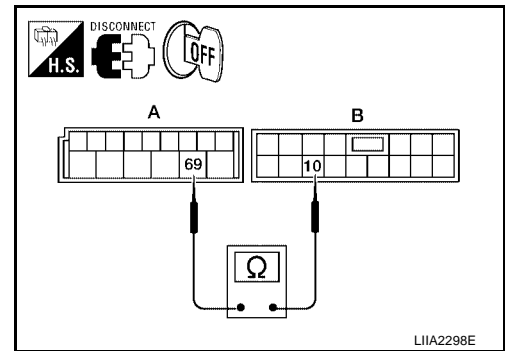

4. CHECK BCM OUTPUT SIGNAL

1. Connect BCM.
2. Turn ignition switch ON.
3. Check voltage between BCM connector M20 terminal 69 and ground.

69 - Ground : Battery voltage

OK or NG

- OK >> Check the condition of the harness and the connector.
NG >> Replace BCM. Refer to [BCS-26, "Removal and Installation"](#) .

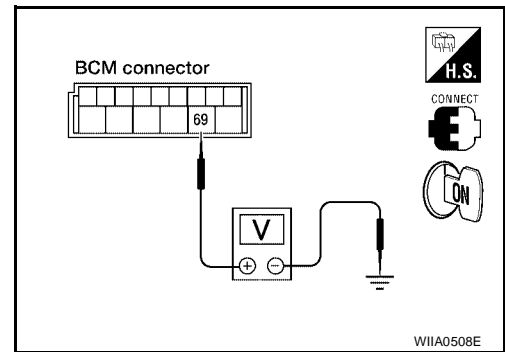

POWER WINDOW SYSTEM

EIS009Z2

Front Power Window Motor LH Circuit Check

1. CHECK MAIN POWER WINDOW AND DOOR LOCK/UNLOCK SWITCH OUTPUT SIGNAL

1. Turn ignition switch ON.
2. Check voltage between main power window and door lock/unlock switch connector D7 terminal 8, 11 and ground.

Connector	Terminals		Condition	Voltage (V) (Approx.)
	(+)	(-)		
D7	8	Ground	UP	Battery voltage
			DOWN	0
	11		UP	0
			DOWN	Battery voltage

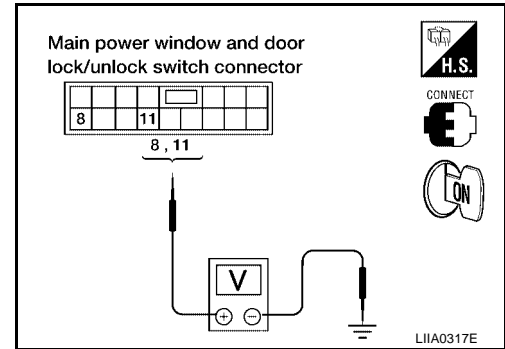

OK or NG

OK >> GO TO 2.

NG >> Replace main power window and door lock/unlock switch. Refer to [EI-28, "DOOR FINISHER"](#) .

2. CHECK POWER WINDOW MOTOR CIRCUIT

1. Turn ignition switch OFF.
2. Disconnect main power window and door lock/unlock switch and front power window motor LH.
3. Check continuity between main power window and door lock/unlock switch connector D7 terminal 8, 11 and front power window motor LH connector D9 terminal 1, 2.

8 - 2 : Continuity should exist.

11 - 1 : Continuity should exist.

OK or NG

OK >> Replace front power window motor LH. Refer to [GW-58, "FRONT DOOR GLASS AND REGULATOR"](#) .

NG >> Repair or replace harness.

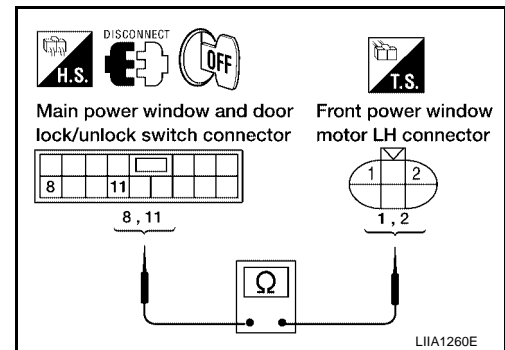

Front Power Window Motor RH Circuit Check

EIS009Z3

1. CHECK POWER WINDOW AND DOOR LOCK/UNLOCK SWITCH RH OUTPUT SIGNAL

1. Turn ignition switch ON.
2. Check voltage between power window and door lock/unlock switch RH connector D105 terminal 8, 9 and ground.

Connector	Terminals		Condition	Voltage (V) (Approx.)
	(+)	(-)		
D105	9	Ground	UP	0
			DOWN	Battery voltage
	8		UP	Battery voltage
			DOWN	0

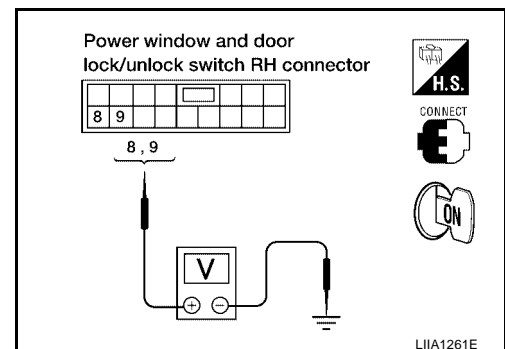

OK or NG

OK >> GO TO 2.

NG >> Replace power window and door lock/unlock switch RH. Refer to [EI-28, "DOOR FINISHER"](#) .

POWER WINDOW SYSTEM

2. CHECK FRONT POWER WINDOW MOTOR RH CIRCUIT

1. Turn ignition switch OFF.
2. Disconnect front power window motor RH and power window and door lock/unlock switch RH.
3. Check continuity between power window and door lock/unlock switch RH connector D105 terminals 8, 9 and front power window motor RH connector D104 terminals 1, 2.

8 - 2 : Continuity should exist.

9 - 1 : Continuity should exist.

OK or NG

OK >> Replace front power window motor RH. Refer to [GW-58](#), "[FRONT DOOR GLASS AND REGULATOR](#)".

NG >> Repair or replace harness.

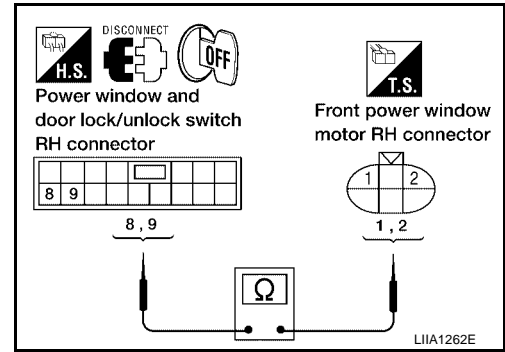

Limit Switch Circuit Check Front LH

EIS009Z4

1. CHECK MAIN POWER WINDOW AND DOOR LOCK/UNLOCK SWITCH LIMIT SIGNAL

1. Turn ignition switch ON.
2. Check voltage between main power window and door lock/unlock switch connector D7 terminal 9 and ground.

Connector	Terminal		Condition	Voltage (V) (Approx.)
	(+)	(-)		
D7	9	Ground	Front window LH is between fully-open and just before fully-closed position (ON)	0
			Front window LH is between just before fully-closed position and fully-closed position (OFF)	5

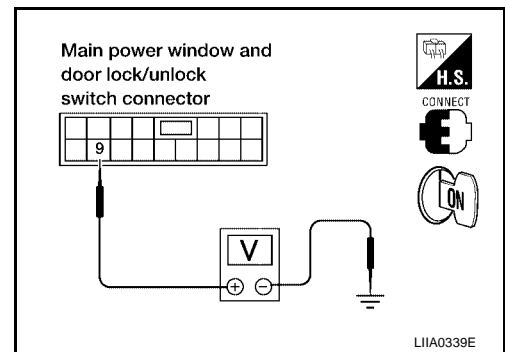

OK or NG

OK >> Limit switch circuit is OK.

NG >> GO TO 2.

2. CHECK FRONT POWER WINDOW MOTOR LH LIMIT SIGNAL

1. Turn ignition switch OFF.
2. Disconnect front power window motor LH.
3. Turn ignition switch ON.
4. Check voltage between front power window motor LH connector D9 terminal 5 and ground.

5 - Ground : Approx. 5V

OK or NG

OK >> GO TO 3.

NG >> GO TO 5.

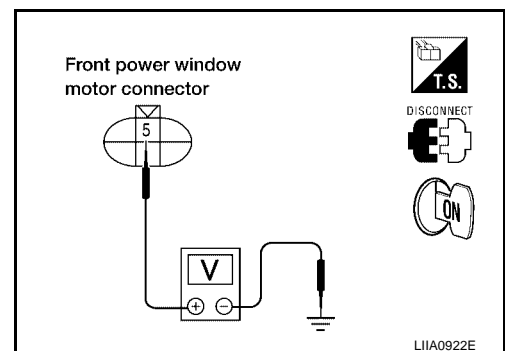

POWER WINDOW SYSTEM

3. CHECK LIMIT SWITCH GROUND CIRCUIT

1. Turn ignition switch OFF.
2. Check continuity between front power window motor LH connector D9 terminal 6 and ground.

6 - Ground : Continuity should exist.

OK or NG

- OK >> Replace front power window motor LH. Refer to [GW-58, "FRONT DOOR GLASS AND REGULATOR"](#).
- NG >> GO TO 4.

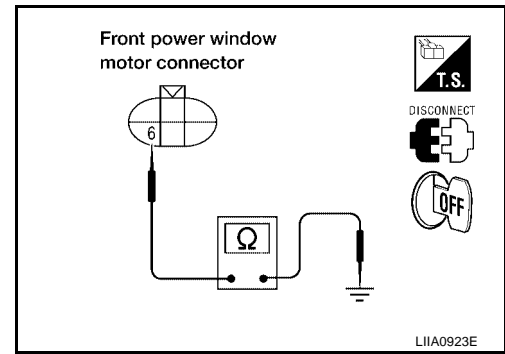

4. CHECK HARNESS CONTINUITY

1. Disconnect main power window and door lock/unlock switch.
2. Check continuity between front power window motor LH connector D9 terminal 6 and main power window and door lock/unlock switch connector D7 terminal 2.

6 - 2 : Continuity should exist.

OK or NG

- OK >> Replace main power window and door lock/unlock switch. Refer to [EI-28, "DOOR FINISHER"](#).
- NG >> Repair or replace harness.

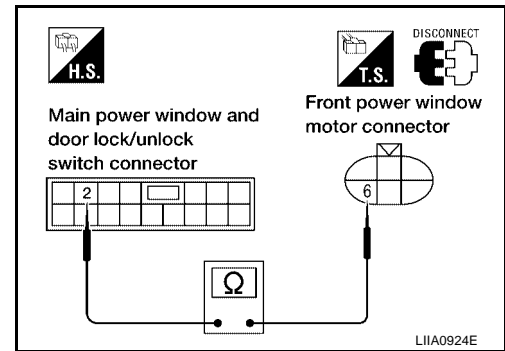

5. CHECK HARNESS CONTINUITY

1. Disconnect main power window and door lock/unlock switch.
2. Check continuity between front power window motor LH connector D9 terminal 5 and main power window and door lock/unlock switch connector D7 terminal 9.

5 - 9 : Continuity should exist.

OK or NG

- OK >> Replace main power window and door lock/unlock switch. Refer to [EI-28, "DOOR FINISHER"](#).
- NG >> Repair or replace harness.

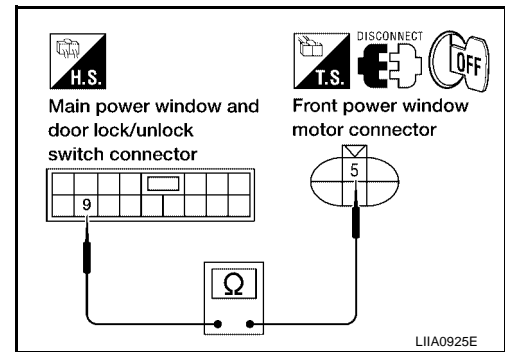

POWER WINDOW SYSTEM

EIS009Z5

Limit Switch Circuit Check Front RH

1. CHECK POWER WINDOW AND DOOR LOCK/UNLOCK SWITCH RH LIMIT SIGNAL

1. Turn ignition switch ON.
2. Check voltage between power window and door lock/unlock switch RH connector D105 terminal 15 and ground.

Connector	Terminals		Condition	Voltage (V) (Approx.)
	(+)	(-)		
D105	15	Ground	Front window RH is between fully-open and just before fully-closed position (ON)	0
			Front windowRH is between just before fully-closed position and fully-closed position (OFF)	5

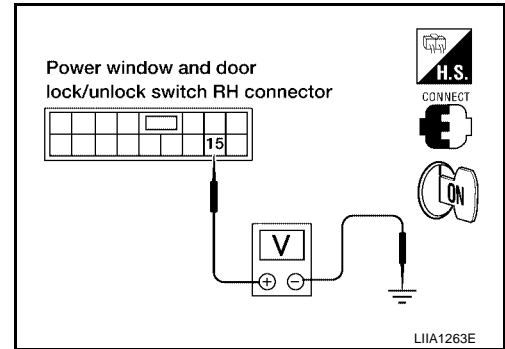

OK or NG

- OK >> Limit switch circuit is OK.
- NG >> GO TO 2.

2. CHECK LIMIT SWITCH GROUND CIRCUIT

1. Turn ignition switch OFF.
2. Disconnect front power window motor RH.
3. Turn ignition switch ON.
4. Check voltage between front power window motor RH connector D104 terminal 6 and ground.

5 - Ground : Approx. 5V

OK or NG

- OK >> GO TO 3.
- NG >> GO TO 5.

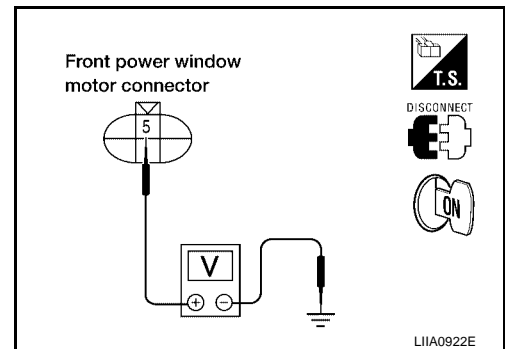

3. CHECK LIMIT SWITCH GROUND CIRCUIT

1. Turn ignition switch OFF.
2. Check continuity between front power window motor RH connector D104 terminal 6 and ground.

6 - Ground : Continuity should exist.

OK or NG

- OK >> Replace front power window motor RH. Refer to [GW-58](#), "[FRONT DOOR GLASS AND REGULATOR](#)".
- NG >> GO TO 4.

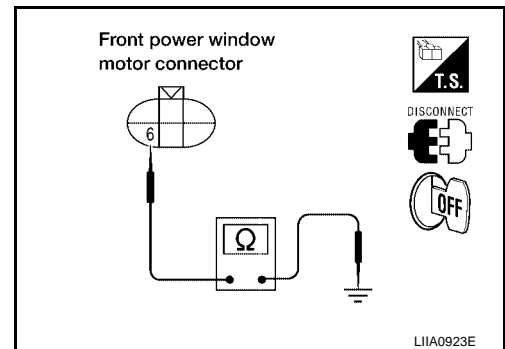

A
B
C
D
E
F
G
H
GW
J
K
L
M

POWER WINDOW SYSTEM

4. CHECK HARNESS CONTINUITY

1. Disconnect power window and door lock/unlock switch RH.
2. Check continuity between front power window motor RH connector D104 terminal 6 and power window and door lock/unlock switch RH connector D105 terminal 3.

6 - 3 : Continuity should exist.

OK or NG

- OK >> Replace power window and door lock/unlock switch RH.
Refer to [EI-28, "DOOR FINISHER"](#).
- NG >> Repair or replace harness.

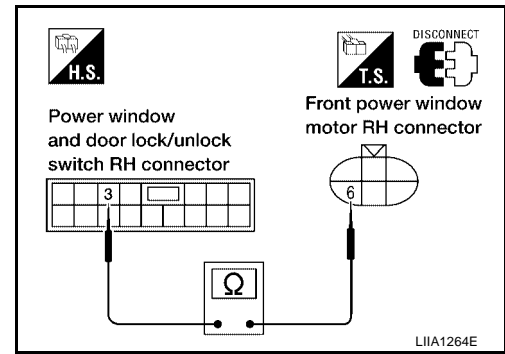

5. CHECK HARNESS CONTINUITY

1. Turn ignition switch OFF.
2. Disconnect power window and door lock/unlock switch RH.
3. Check continuity between power window and door lock/unlock switch RH connector D105 terminal 15 and front power window motor RH connector D104 terminal 5.

15 - 5 : Continuity should exist.

OK or NG

- OK >> Replace power window and door lock/unlock switch RH.
Refer to [EI-28, "DOOR FINISHER"](#).
- NG >> Repair or replace harness.

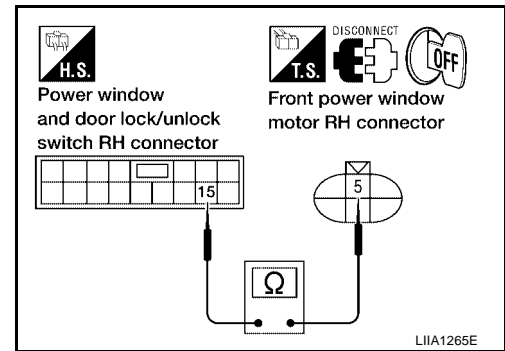

Encoder Circuit Check Front LH

EIS009Z6

1. CHECK FRONT POWER WINDOW MOTOR LH POWER SUPPLY

1. Turn ignition switch OFF.
2. Disconnect front power window motor LH.
3. Turn ignition switch ON.
4. Check voltage between front power window motor LH connector D9 terminal 4 and ground.

4 - Ground : Approx. 10V

OK or NG

- OK >> GO TO 3.
- NG >> GO TO 2.

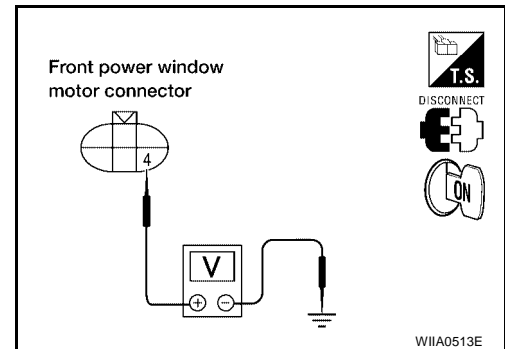

2. CHECK HARNESS CONTINUITY

1. Turn ignition switch OFF.
2. Disconnect main power window and door lock/unlock switch.
3. Check continuity between front power window motor LH connector D9 terminal 4 and main power window and door lock/unlock switch connector D7 terminal 15.

4 - 15 : Continuity should exist.

OK or NG

- OK >> Replace main power window and door lock/unlock switch. Refer to [EI-28, "DOOR FINISHER"](#).
- NG >> Repair or replace harness.

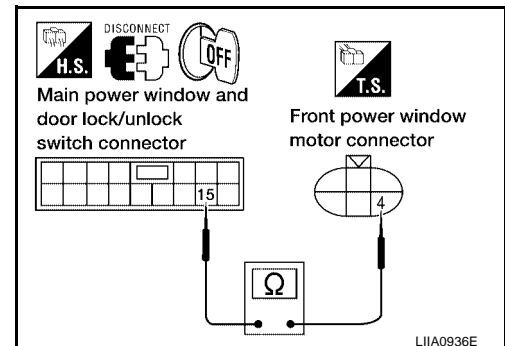

POWER WINDOW SYSTEM

3. CHECK ENCODER GROUND

1. Turn ignition switch OFF.
2. Check continuity between front power window motor LH connector D9 terminal 6 and ground.

6 - Ground : Continuity should exist.

OK or NG

- OK >> GO TO 5.
NG >> GO TO 4.

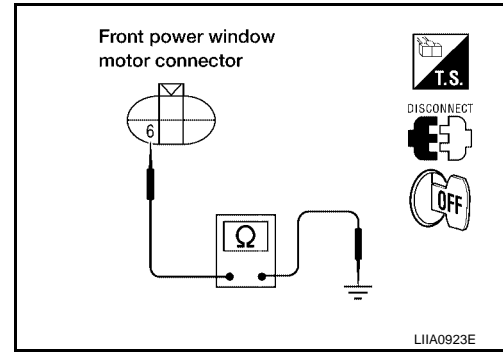

4. CHECK ENCODER GROUND CIRCUIT

1. Disconnect main power window and door lock/unlock switch.
2. Check continuity between front power window motor LH connector D9 terminal 6 and main power window and door lock/unlock switch connector D7 terminal 2.

6 - 2 : Continuity should exist.

OK or NG

- OK >> Replace main power window and door lock/unlock switch. Refer to [EI-28, "DOOR FINISHER"](#).
NG >> Repair or replace harness.

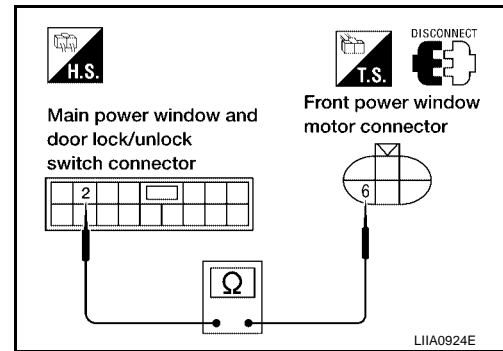

5. CHECK ENCODER SIGNAL

1. Connect front power window motor LH and main power window and door lock/unlock switch.
2. Turn ignition switch ON.
3. Check the signal between main power window and door lock/unlock switch connector and ground with oscilloscope.

Connector	Terminals		Condition	Signal
	(+)	(-)		
D7	13	Ground	Opening	

OCC3383D

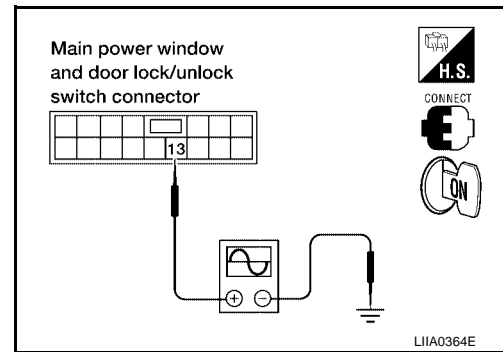

OK or NG

- OK >> Replace main power window and door lock/unlock switch. Refer to [EI-28, "DOOR FINISHER"](#).
NG >> GO TO 6.

POWER WINDOW SYSTEM

6. CHECK ENCODER CIRCUIT

1. Turn ignition switch OFF.
2. Disconnect front power window motor LH and main power window and door lock/unlock switch.
3. Check continuity between front power window motor LH connector D9 terminal 3 and main power window and door lock/unlock switch connector D7 terminal 13.

3 - 13 : Continuity should exist.

OK or NG

OK >> Replace front power window motor LH. Refer to [GW-58, "FRONT DOOR GLASS AND REGULATOR"](#).

NG >> Repair or replace harness.

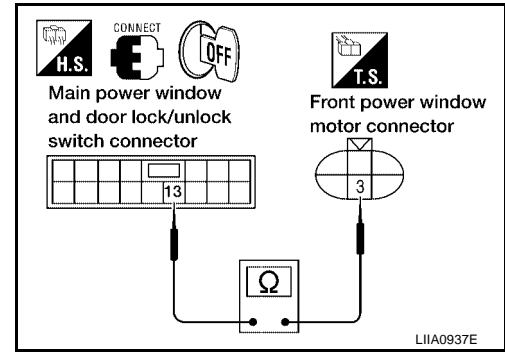

Encoder Circuit Check Front RH

EIS009Z7

1. CHECK FRONT POWER WINDOW MOTOR RH POWER SUPPLY

1. Turn ignition switch OFF.
2. Disconnect front power window motor RH.
3. Turn ignition switch ON.
4. Check voltage between front power window motor RH connector D104 terminal 4 and ground.

4 - Ground : Approx. 10V

OK or NG

OK >> GO TO 3.

NG >> GO TO 2.

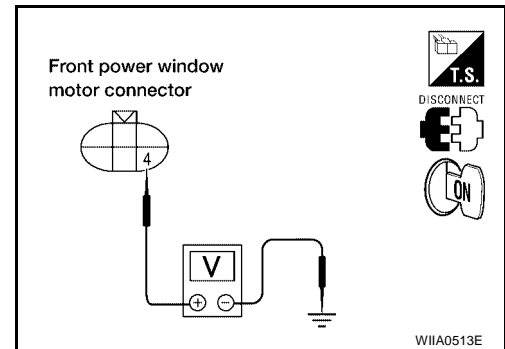

2. CHECK HARNESS CONTINUITY

1. Turn ignition switch OFF.
2. Disconnect power window and door lock/unlock switch RH.
3. Check continuity between front power window motor RH connector D104 terminal 4 and power window and door lock/unlock switch RH connector D105 terminal 4.

4 - 4 : Continuity should exist.

OK or NG

OK >> Replace power window and door lock/unlock switch RH. Refer to [EI-28, "DOOR FINISHER"](#).

NG >> Repair or replace harness.

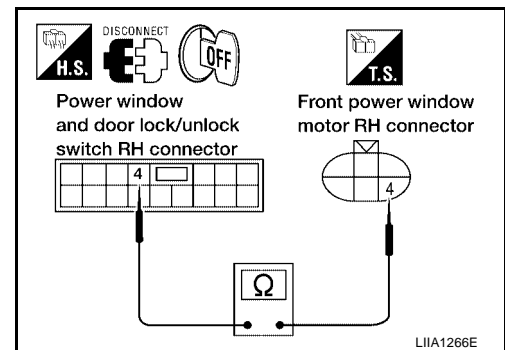

3. CHECK ENCODER GROUND

1. Turn ignition switch OFF.
2. Check continuity between front power window motor RH connector D104 terminal 6 and ground.

6 - Ground : Continuity should exist.

OK or NG

OK >> GO TO 5.

NG >> GO TO 4.

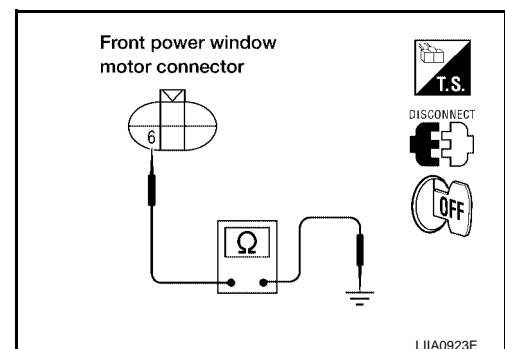

POWER WINDOW SYSTEM

4. CHECK ENCODER GROUND CIRCUIT

1. Disconnect power window and door lock/unlock switch RH.
2. Check continuity between front power window motor RH connector D104 terminal 6 and power window and door lock/unlock switch RH connector D105 terminal 3.

6 - 3 : Continuity should exist.

OK or NG

- OK >> Replace power window and door lock/unlock switch RH. Refer to [EI-28, "DOOR FINISHER"](#) .
- NG >> Repair or replace harness.

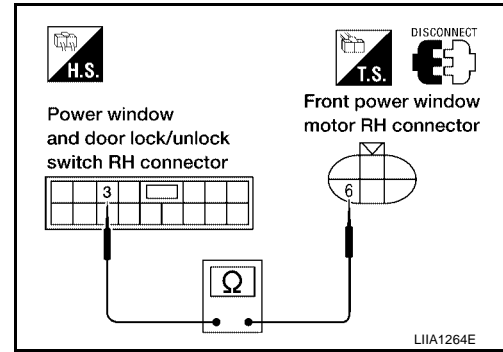

5. CHECK ENCODER SIGNAL

1. Connect front power window motor RH and power window and door lock/unlock switch RH.
2. Turn ignition switch ON.
3. Check the signal between power window and door lock/unlock switch RH connector and ground with oscilloscope.

Connector	Terminals		Condition	Signal
	(+)	(-)		
D105	12	Ground	Opening	<p>OCC3383D</p>

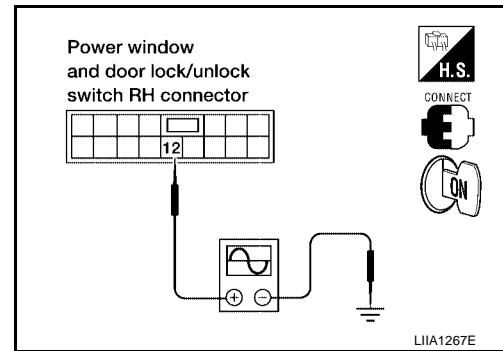

OK or NG

- OK >> Replace power window and door lock/unlock switch RH. Refer to [EI-28, "DOOR FINISHER"](#) .
- NG >> GO TO 6.

6. CHECK ENCODER CIRCUIT

1. Turn ignition switch OFF.
2. Disconnect front power window motor RH and power window and door lock/unlock switch RH.
3. Check continuity between front power window motor RH connector D104 terminal 3 and power window and door lock/unlock switch RH connector D105 terminal 12.

3 - 12 : Continuity should exist.

OK or NG

- OK >> Replace front power window motor RH. Refer to [GW-58, "FRONT DOOR GLASS AND REGULATOR"](#) .
- NG >> Repair or replace harness.

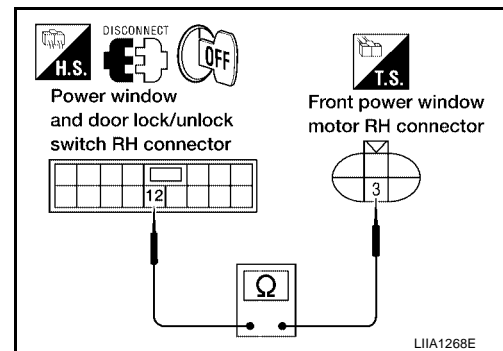

POWER WINDOW SYSTEM

EIS009Z8

Door Switch Check

1. CHECK FRONT DOOR SWITCH INPUT SIGNAL

With CONSULT-II

Check front door switches ("DOOR SW-DR" and "DOOR SW-AS") in "DATA MONITOR" mode with CONSULT-II.

Monitor item	Condition
DOOR SW-DR	OPEN: ON
	CLOSE: OFF
DOOR SW-AS	OPEN: ON
	CLOSE: OFF

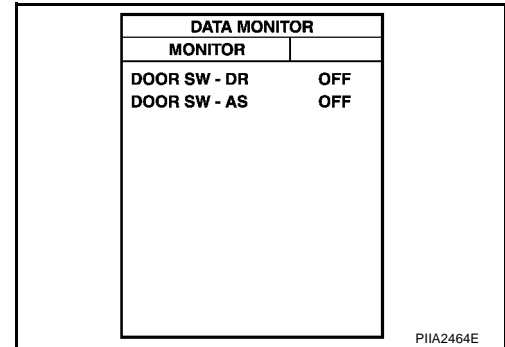

Without CONSULT-II

Check voltage between BCM connector and ground.

Item	Connector	Terminals		Condition	Voltage (V) (Approx.)
		(+)	(-)		
Front RH	M18	12	Ground	OPEN	0
				CLOSE	Battery voltage
Front LH	M19	47		OPEN	0
				CLOSE	Battery voltage

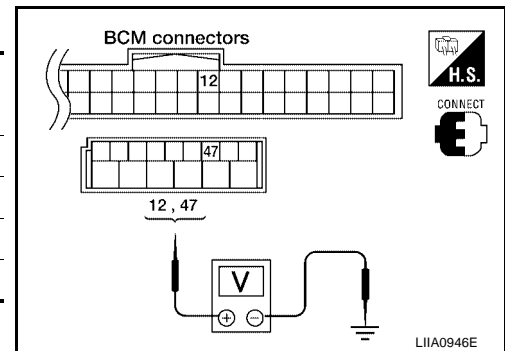

OK or NG

- OK >> Front door switch is OK.
- NG >> GO TO 2.

2. CHECK FRONT DOOR SWITCH CIRCUIT

- Turn ignition switch OFF.
- Disconnect front door switch LH or RH and BCM.
- Check continuity between front door switch connector B8 (LH) or B108 (RH) terminal 2 and BCM connector M19 terminal 47 (LH) or connector M18 terminal 12 (LH).

Front LH
2 - 47 : Continuity should exist.

Front RH
2 - 12 : Continuity should exist.

- Check continuity between front door switch connector B8 (LH) or B108 (RH) terminal 2 and ground.

2 - Ground : Continuity should not exist.

OK or NG

- OK >> GO TO 3.
- NG >> Repair or replace harness.

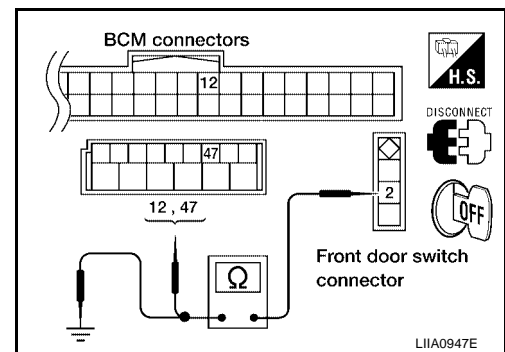

POWER WINDOW SYSTEM

3. CHECK DOOR SWITCH

1. Disconnect front door switch LH or RH.
2. Check continuity between each front door switch terminal 2 and body ground part of front door switch.

Terminal		Door switch	Continuity
2	Body ground part of front door switch	Pushed	No
		Released	Yes

OK or NG

- OK >> Replace BCM. Refer to [BCS-26, "Removal and Installation"](#).
- NG >> Replace malfunctioning front door switch.

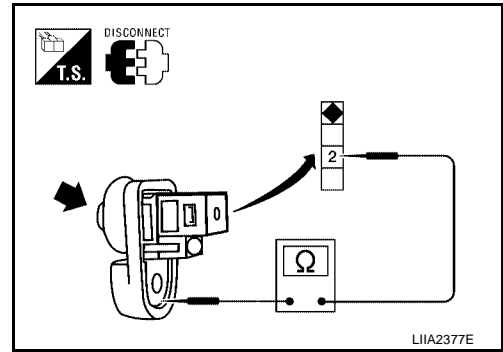

Front Door Lock Assembly (Key Cylinder Switch) Check

EIS00929

1. CHECK FRONT DOOR LOCK ASSEMBLY LH (KEY CYLINDER SWITCH) INPUT SIGNAL

Ⓜ With CONSULT-II

- Check front door lock assembly LH (key cylinder switch) ("KEY CYL LK SW") in "DATA MONITOR" mode for "POWER DOOR LOCK SYSTEM" with CONSULT-II. Refer to [GW-34, "DATA MONITOR"](#).

"KEY CYL LK-SW" should be "ON" when key inserted in door key cylinder is turned to lock.

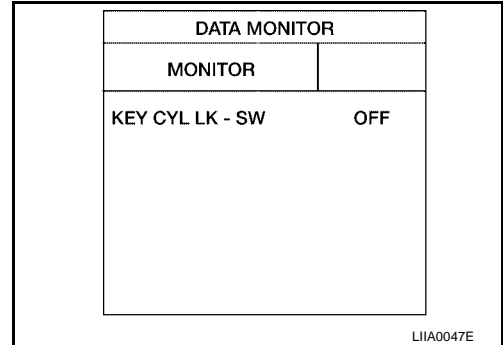

- Check front door lock assembly LH (key cylinder switch) ("KEY CYL UN-SW") in "DATA MONITOR" mode for "POWER DOOR LOCK SYSTEM" with CONSULT-II. Refer to [GW-34, "DATA MONITOR"](#).

"KEY CYL UN-SW" should be "ON" when key inserted in door key cylinder is turned to unlock.

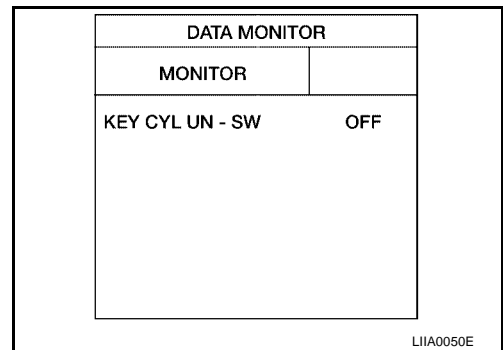

ⓧ Without CONSULT-II

Check voltage between main power window and door lock/unlock switch connector and ground.

Connector	Terminals		Key position	Voltage (V) (Approx.)
	(+)	(-)		
D7	6	Ground	Neutral/Lock	5
			Lock	0
	4		Neutral/Unlock	5
			Unlock	0

OK or NG

- OK >> Front door lock assembly LH (key cylinder switch) is OK.
- NG >> GO TO 2.

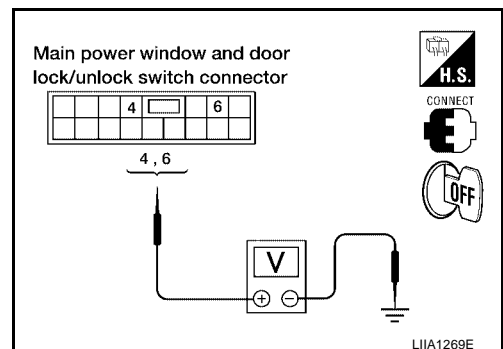

POWER WINDOW SYSTEM

2. CHECK FRONT DOOR LOCK ASSEMBLY LH (KEY CYLINDER SWITCH) CIRCUIT

1. Turn ignition switch OFF.
2. Disconnect main power window and door lock/unlock switch and front door lock assembly LH (key cylinder switch).
3. Check continuity between main power window and door lock/unlock switch connector D7 terminals 4, 6 and front door lock assembly LH (key cylinder switch) connector D14 terminals 1, 6.

6 - 6 : Continuity should exist.

4 - 1 : Continuity should exist.

OK or NG

OK >> GO TO 3.

NG >> Repair or replace harness.

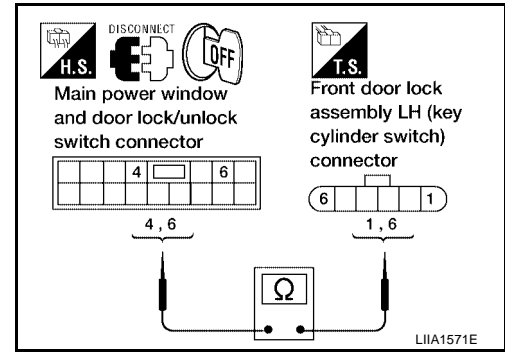

3. CHECK FRONT DOOR LOCK ASSEMBLY LH (KEY CYLINDER SWITCH) GROUND

Check continuity between front door lock assembly LH (key cylinder switch) connector D14 terminal 5 and ground.

5 - Ground : Continuity should exist.

OK or NG

OK >> GO TO 4.

NG >> Repair or replace harness.

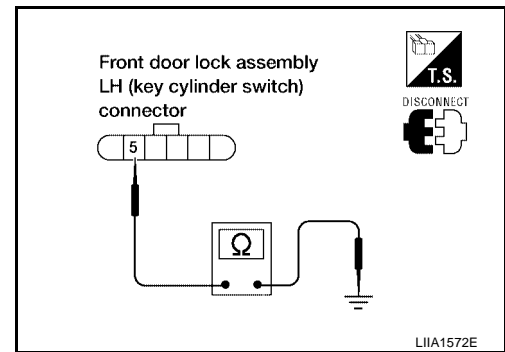

4. CHECK FRONT DOOR LOCK ASSEMBLY LH (KEY CYLINDER SWITCH)

Check continuity between door key cylinder switch LH terminals 1, 6 and 5.

Terminals		Key position	Continuity
6	5	Neutral/Lock	No
		Unlock	Yes
1		Neutral/Unlock	No
		Lock	Yes

OK or NG

OK >> Replace main power window and door lock/unlock switch. Refer to [EI-28, "DOOR FINISHER"](#).

NG >> Replace front door lock assembly LH (key cylinder switch). Refer to [BL-119, "FRONT DOOR LOCK"](#).

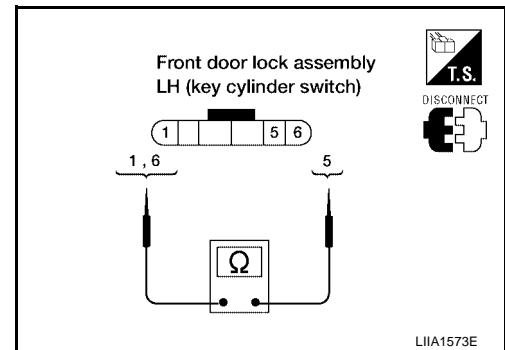

POWER WINDOW SYSTEM

EIS009ZA

Power Window Serial Link Check Front LH and RH

1. CHECK BUS OUTPUT SIGNAL

With CONSULT-II

Check door lock and unlock switch ("LOCK SW DR/AS", "UNLK SW DR/AS") in DATA MONITOR mode for "MULTI REMOTE ENT" with CONSULT-II. Refer to [BL-46, "Data Monitor"](#).

- When door lock and unlock switch is turned to LOCK
LOCK SW DR/AS : ON
- When door lock and unlock switch is turned to UNLOCK
UNLK SW DR/AS : ON

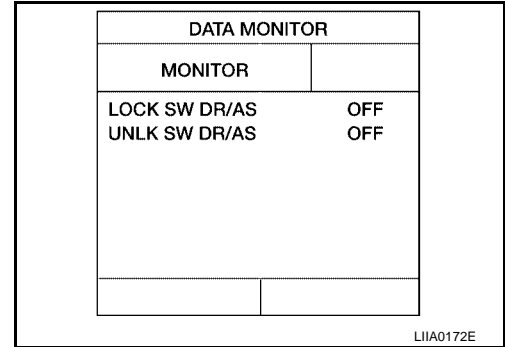

Without CONSULT-II

- Remove key from ignition switch, and the door of driver side and passenger side is closed.
- Check the signal between BCM connector and ground with oscilloscope when door lock and unlock switch (front LH and front RH) is turned "LOCK" or "UNLOCK".
- Make sure signals which are shown in the figure below can be detected during 10 second just after door lock and unlock switch (front LH and front RH) is turned "LOCK" or "UNLOCK".

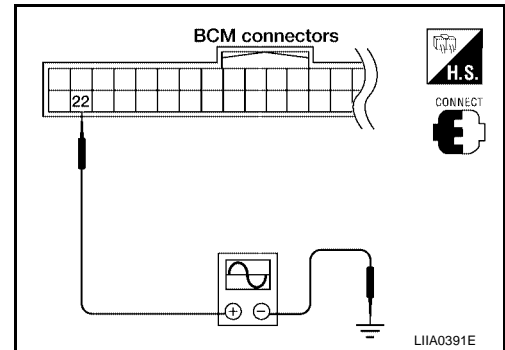

Connector	Terminals		Signal
	(+)	(-)	
M18	22	Ground	<p>(V) 15 10 5 0</p> <p>10 ms</p> <p>PIIA1297E</p>

OK or NG

- OK >> GO TO 2.
- NG >> GO TO 3.

2. CHECK BCM OUTPUT SIGNAL

Check BUS ("POWER WINDOW DOWN") in "ACTIVE TEST" mode with CONSULT-II. Refer to [BL-47, "Active Test"](#).

When "ACTIVE TEST" is executed, is the front power window LH and RH lowered?

YES or NO

- YES >> Further inspection is necessary. Refer to symptom chart.
- NO >> Replace BCM. Refer to [BCS-26, "Removal and Installation"](#).

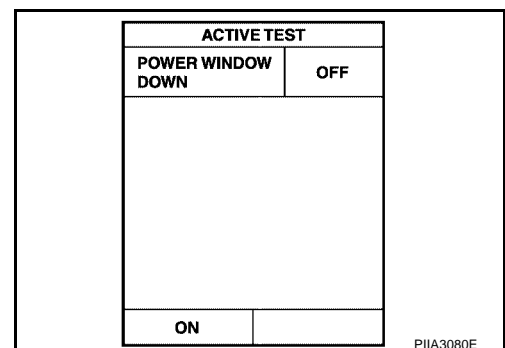

POWER WINDOW SYSTEM

3. CHECK POWER WINDOW SWITCH GROUND

1. Turn ignition switch OFF.
2. Disconnect main power window and door lock/unlock switch and power window and door lock/unlock switch RH.
3. Check continuity between main power window and door lock/unlock switch connector D8 terminal 17 and ground.

17 - Ground : Continuity should exist.

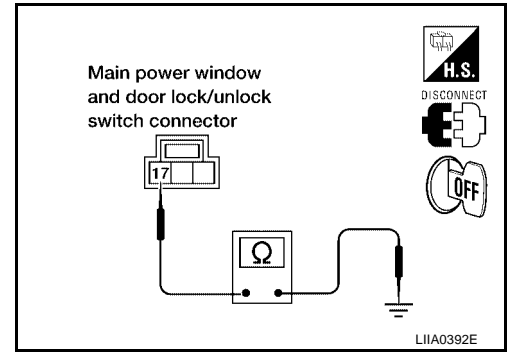

4. Check continuity between power window and door lock/unlock switch RH connector D105 terminal 11 and ground.

11 - Ground : Continuity should exist.

OK or NG

- OK >> GO TO 4.
- NG >> Repair or replace harness.

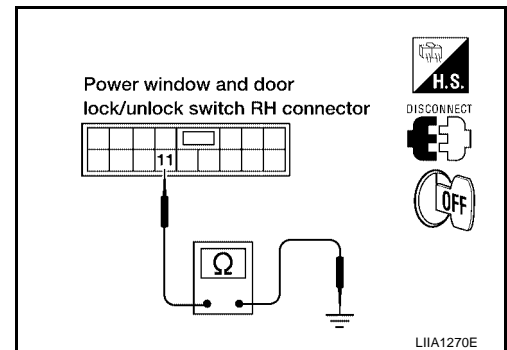

4. CHECK BUS CIRCUIT

1. Disconnect BCM.
2. Check continuity between BCM connector M18 terminal 22 and main power window and door lock/unlock switch connector D7 terminal 14.

22 - 14 : Continuity should exist.

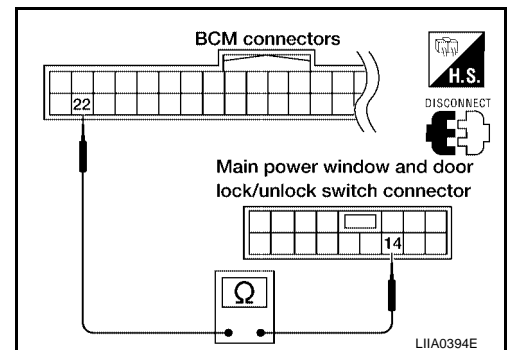

3. Check continuity between BCM connector M18 terminal 22 and power window and door lock/unlock switch RH connector D105 terminal 16.

22 - 16 : Continuity should exist.

OK or NG

- OK >> Replace main power window and door lock/unlock switch or front power window and door lock/unlock switch RH. Refer to [EI-28, "DOOR FINISHER"](#).
- NG >> Repair or replace harness.

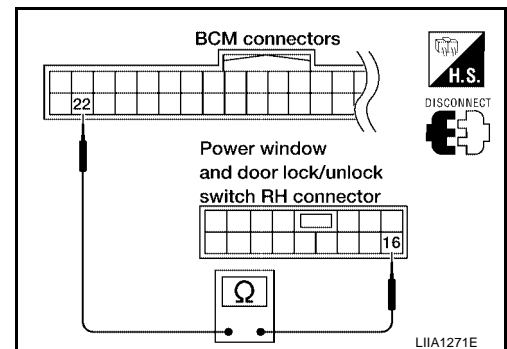

POWER WINDOW SYSTEM

EIS0092B

Rear Power Window Motor LH Circuit Check

1. CHECK REAR POWER WINDOW SWITCH LH OUTPUT SIGNAL

1. Turn ignition switch OFF.
2. Disconnect rear power window motor LH.
3. Turn ignition switch ON.
4. Check voltage between rear power window motor LH connector D204 terminals 1, 2 and ground.

Connector	Terminals		Condition	Voltage (V) (Approx.)
	(+)	(-)		
D204	1	Ground	UP	Battery voltage
			DOWN	0
	2		UP	0
			DOWN	Battery voltage

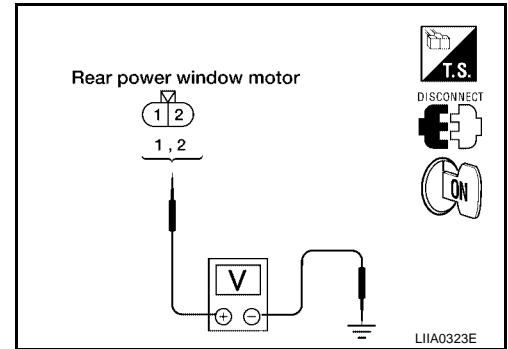

OK or NG

- OK >> Replace rear power window motor LH. Refer to [GW-61, "REAR DOOR GLASS AND REGULATOR"](#).
- NG >> GO TO 2.

2. CHECK REAR POWER WINDOW MOTOR LH CIRCUIT

1. Turn ignition switch OFF.
2. Disconnect rear power window switch LH.
3. Check continuity between rear power window switch LH connector D203 terminals 4, 5 and rear power window motor LH connector D204 terminal 1, 2.

4 - 1 : Continuity should exist.

5 - 2 : Continuity should exist.

OK or NG

- OK >> GO TO 3.
- NG >> Repair or replace harness.

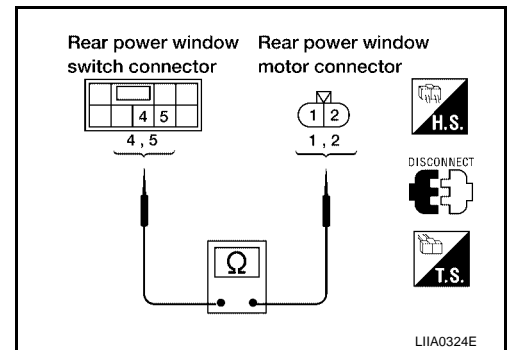

3. CHECK POWER SUPPLY

1. Connect rear power window switch LH.
2. Turn ignition switch ON.
3. Check voltage between rear power window switch LH connector D203 terminal 1 and ground.

1 - Ground : Battery voltage

OK or NG

- OK >> GO TO 4.
- NG >> Repair or replace harness.

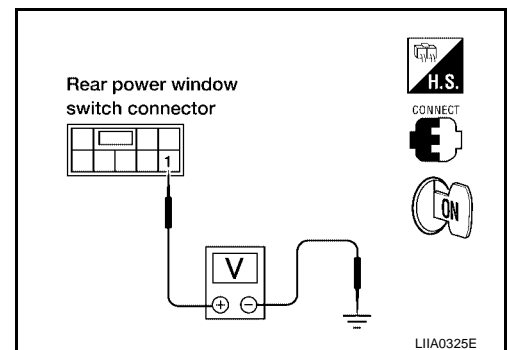

POWER WINDOW SYSTEM

4. CHECK MAIN POWER WINDOW AND DOOR LOCK/UNLOCK SWITCH OUTPUT SIGNAL

1. Turn ignition switch OFF.
2. Confirm that power window lock switch is in unlocked position.
3. Check continuity between main power window and door lock/unlock switch connector D7 terminal 1, 3 and connector D8 terminal 17.

1 - 17 : Continuity should exist.

3 - 17 : Continuity should exist.

OK or NG

- OK >> Repair or replace harness.
 NG >> Replace main power window and door lock/unlock switch. Refer to [EI-28, "DOOR FINISHER"](#).

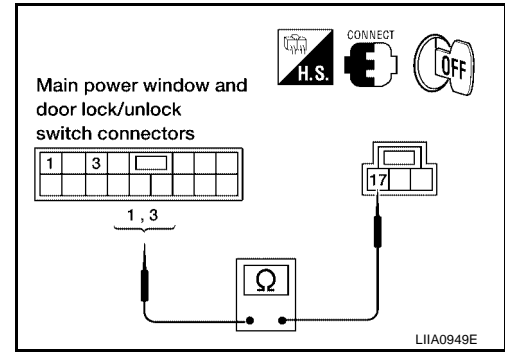

Rear Power Window Motor RH Circuit Check

EIS0092C

1. CHECK REAR POWER WINDOW SWITCH RH OUTPUT SIGNAL

1. Turn ignition switch OFF.
2. Disconnect rear power window motor RH.
3. Turn ignition switch ON.
4. Check voltage between rear power window motor RH connector D304 terminals 1, 2 and ground.

Connector	Terminals		Condition	Voltage (V) (Approx.)
	(+)	(-)		
D304	1	Ground	UP	Battery voltage
			DOWN	0
	2		UP	0
			DOWN	Battery voltage

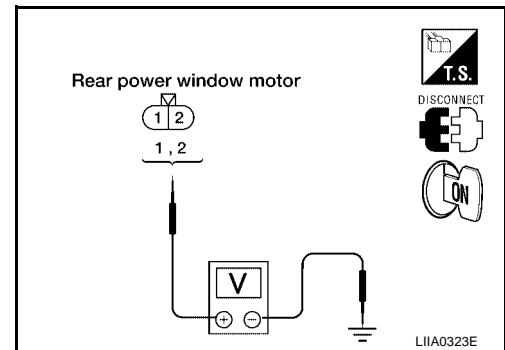

OK or NG

- OK >> Replace rear power window motor RH. Refer to [GW-61, "REAR DOOR GLASS AND REGULATOR"](#).
 NG >> GO TO 2.

2. CHECK REAR POWER WINDOW MOTOR RH CIRCUIT

1. Turn ignition switch OFF.
2. Disconnect rear power window switch RH.
3. Check continuity between rear power window switch RH connector D303 terminals 4, 5 and rear power window motor RH connector D304 terminal 1, 2.

4 - 1 : Continuity should exist.

5 - 2 : Continuity should exist.

OK or NG

- OK >> GO TO 3.
 NG >> Repair or replace harness.

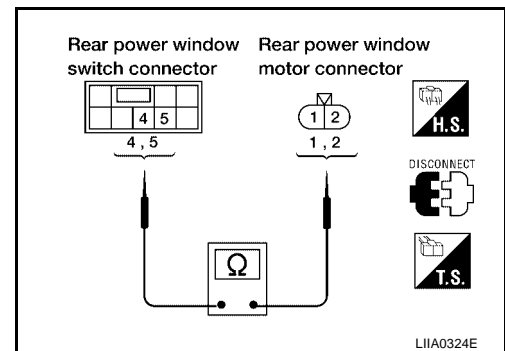

POWER WINDOW SYSTEM

3. CHECK POWER SUPPLY

1. Connect rear power window switch RH.
2. Turn ignition switch ON.
3. Check voltage between rear power window switch RH connector D303 terminal 1 and ground.

1 - Ground : Battery voltage

OK or NG

- OK >> GO TO 4.
 NG >> Repair or replace harness.

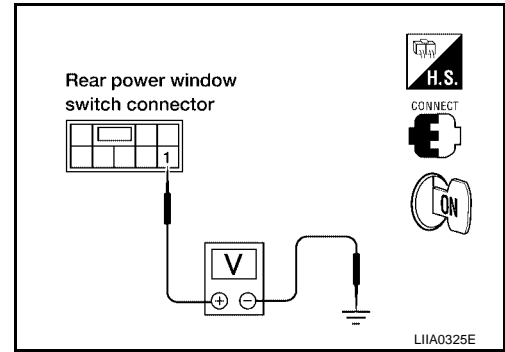

4. CHECK MAIN POWER WINDOW AND DOOR LOCK/UNLOCK SWITCH OUTPUT SIGNAL

1. Confirm that power window lock switch is in unlocked position.
2. Check continuity between main power window and door lock/unlock switch connector D7 terminals 5, 7 and connector D8 terminal 17.

5 - 17 : Continuity should exist.
7 - 17 : Continuity should exist.

OK or NG

- OK >> Repair or replace harness.
 NG >> Replace main power window and door lock/unlock switch. Refer to [EI-28, "DOOR FINISHER"](#).

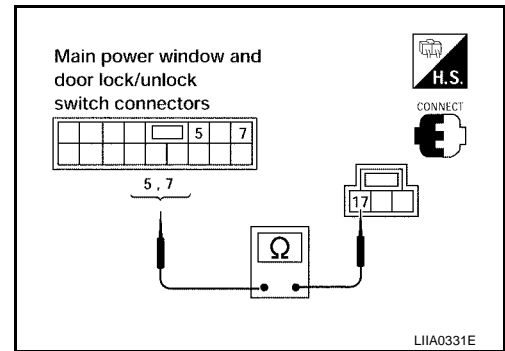

Rear Power Vent Window Switch Circuit Check

EIS0092D

1. CHECK REAR POWER VENT WINDOW SWITCH OPERATION

1. Turn ignition switch OFF.
2. Disconnect rear power vent window switch.
3. Check continuity between rear power vent window switch terminals 1, 3 and 4.

Terminals	Condition	Continuity
3 1	Rear power vent window switch is pressed OPEN.	Yes
4 1	Rear power vent window switch is pressed CLOSE.	Yes

OK or NG

- OK >> GO TO 2.
 NG >> Replace rear power vent window switch.

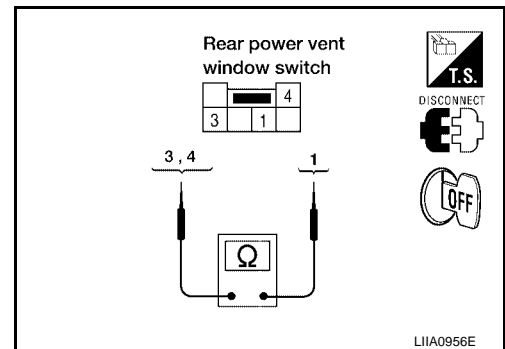

2. CHECK REAR POWER VENT WINDOW SWITCH CIRCUIT HARNESS CONTINUITY

Check continuity between rear power vent window switch connector R103 terminal 1 and ground.

1 - Ground : Continuity should exist.

OK or NG

- OK >> Rear power vent window switch circuit harness OK.
 NG >> Repair or replace harness.

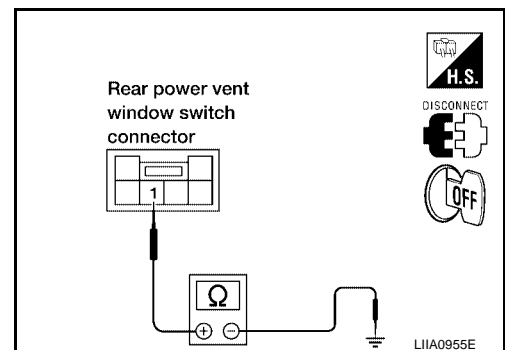

A
B
C
D
E
F
G
H
J
K
L
M

GW

POWER WINDOW SYSTEM

EIS009ZE

Rear Power Vent Window Motor LH Circuit Check

1. CHECK REAR POWER VENT WINDOW LH SIGNAL

1. Turn ignition switch OFF.
2. Disconnect rear power vent window motor LH.
3. Turn ignition switch ON.
4. Check voltage between rear power vent window motor LH connector B52 terminals 1, 2 and ground.

Connector	Terminals		Condition	Voltage (V) (Approx.)
	(+)	(-)		
B52	1	Ground	Opening	Battery voltage
			Closing	0
	2		Opening	0
			Closing	Battery voltage

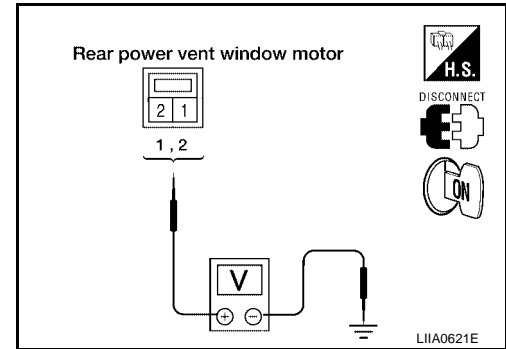

OK or NG

- OK >> Replace rear power vent window motor LH. Refer to [GW-65, "Removal and Installation \(with Rear Power Vent Windows\)"](#).
- NG >> Repair or replace harness.

Rear Power Vent Window Motor RH Circuit Check

EIS009ZF

1. CHECK REAR POWER VENT WINDOW SWITCH RH SIGNAL

1. Turn ignition switch OFF.
2. Disconnect rear power vent window motor RH.
3. Turn ignition switch ON.
4. Check voltage between rear power vent window motor LH connector B150 terminals 1, 2 and ground.

Connector	Terminals		Condition	Voltage (V) (Approx.)
	(+)	(-)		
B150	1	Ground	Opening	Battery voltage
			Closing	0
	2		Opening	0
			Closing	Battery voltage

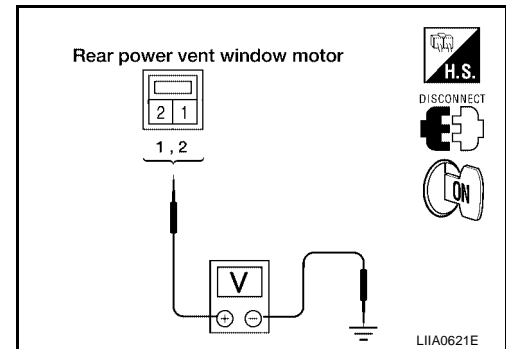

OK or NG

- OK >> Replace rear power vent window motor RH. Refer to [GW-65, "Removal and Installation \(with Rear Power Vent Windows\)"](#).
- NG >> Repair or replace harness.

POWER WINDOW SYSTEM

EIS009ZG

Rear Power Vent Window Relay (OPEN) Check

1. CHECK REAR POWER VENT WINDOW RELAY (OPEN) POWER SUPPLY CIRCUIT

1. Turn ignition switch OFF.
2. Disconnect rear power vent window relay (OPEN).
3. Turn ignition switch ON.
4. Check voltage between rear power vent window relay (OPEN) connector and ground.

Connector	Terminals		Voltage (V) (Approx.)
	(+)	(-)	
M87	1	Ground	Battery voltage
	5		

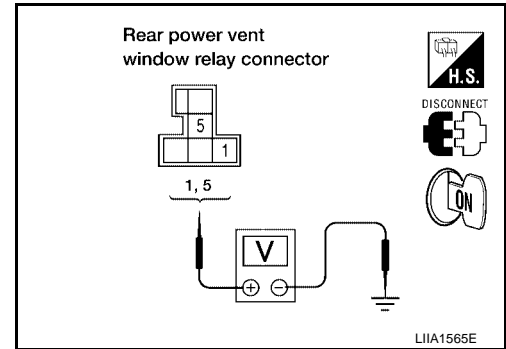

OK or NG

- OK >> GO TO 2.
 NG >> Repair or replace harness.

2. CHECK REAR POWER VENT WINDOW RELAY (OPEN)

Check continuity between rear power vent window relay (OPEN) terminals 3 and 4, 3 and 5.

Terminals	Condition	Continuity
3 4	12V direct current supply between terminals 1 and 2	No
	No current supply	Yes
3 5	12V direct current supply between terminals 1 and 2	Yes
	No current supply	No

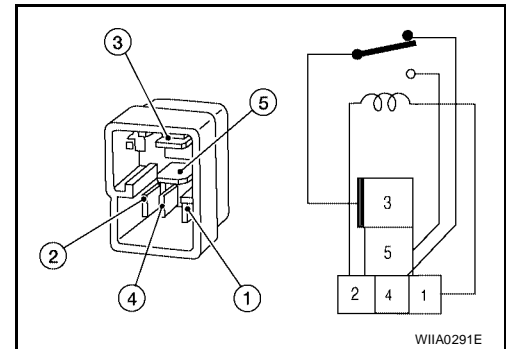

OK or NG

- OK >> GO TO 3.
 NG >> Replace rear power vent window relay (OPEN).

3. CHECK REAR POWER VENT WINDOW RELAY (OPEN) GROUND CIRCUIT

Check continuity between rear power vent window relay (OPEN) connector M87 terminal 4 and ground.

4 - Ground : Continuity should exist.

OK or NG

- OK >> GO TO 4.
 NG >> Repair or replace harness.

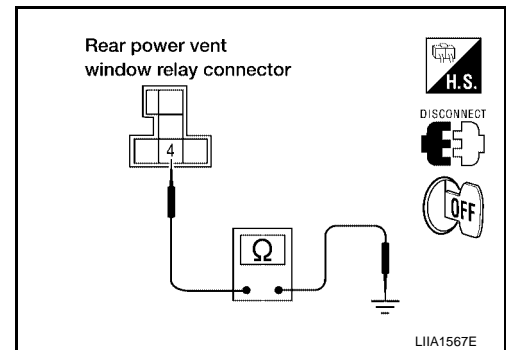

POWER WINDOW SYSTEM

4. CHECK REAR POWER VENT WINDOW RELAY (OPEN) CIRCUIT

1. Disconnect rear power vent window switch.
2. Check continuity between rear power vent window relay (OPEN) connector M87 terminal 2 and rear power vent window switch connector R103 terminal 3.

2 - 3 : Continuity should exist.

OK or NG

- OK >> Replace rear power vent window switch.
 NG >> Repair or replace harness.

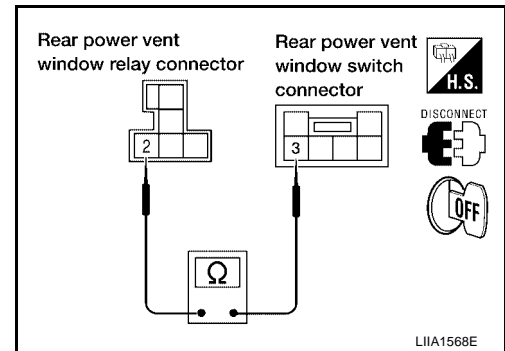

Rear Power Vent Window Relay (CLOSE) Check

EIS009ZH

1. CHECK REAR POWER VENT WINDOW RELAY (CLOSE) POWER SUPPLY CIRCUIT

1. Turn ignition switch OFF.
2. Disconnect rear power vent window relay (CLOSE).
3. Turn ignition switch ON.
4. Check voltage between rear power vent window relay (CLOSE) connector and ground.

Connector	Terminals		Voltage (V) (Approx.)
	(+)	(-)	
M89	1	Ground	Battery voltage
	5		

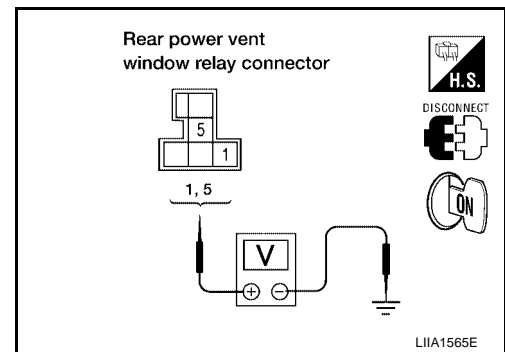

OK or NG

- OK >> GO TO 2.
 NG >> Repair or replace harness.

2. CHECK REAR POWER VENT WINDOW RELAY (CLOSE)

Check continuity between rear power vent window relay (CLOSE) terminals 3 and 4, 3 and 5.

Terminals		Condition	Continuity
3	4	12V direct current supply between terminals 1 and 2	No
		No current supply	Yes
3	5	12V direct current supply between terminals 1 and 2	Yes
		No current supply	No

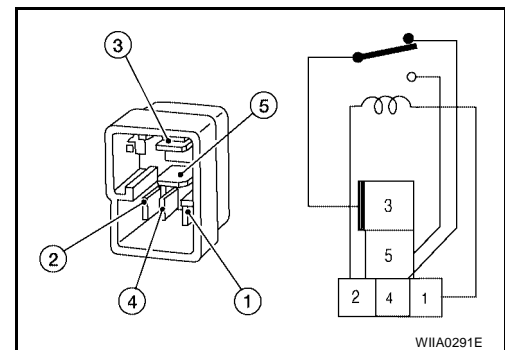

OK or NG

- OK >> GO TO 3.
 NG >> Replace rear power vent window relay (CLOSE).

POWER WINDOW SYSTEM

3. CHECK REAR POWER VENT WINDOW RELAY (CLOSE) GROUND CIRCUIT

Check continuity between rear power vent window relay (CLOSE) connector M89 terminal 4 and ground.

4 - Ground : Continuity should exist.

OK or NG

- OK >> GO TO 4.
- NG >> Repair or replace harness.

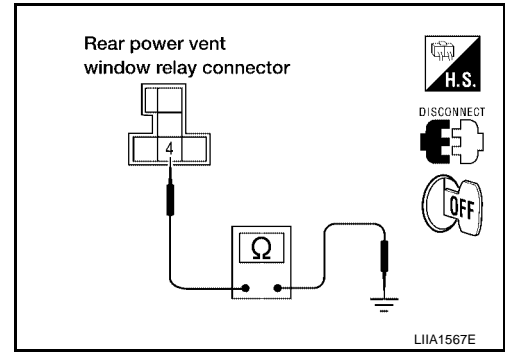

4. CHECK REAR POWER VENT WINDOW RELAY (CLOSE) CIRCUIT

1. Disconnect rear power vent window switch.
2. Check continuity between rear power vent window relay (CLOSE) connector M89 terminal 2 and rear power vent window switch R103 terminal 4.

2 - 4 : Continuity should exist.

OK or NG

- OK >> Replace rear power vent window switch.
- NG >> Repair or replace harness.

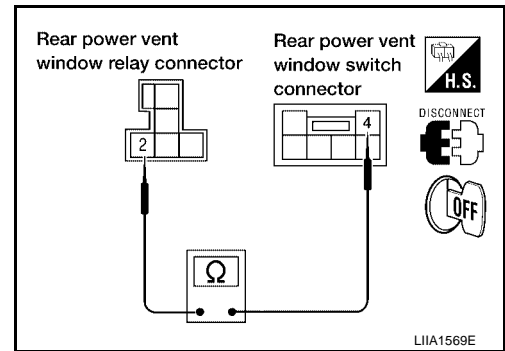

A
B
C
D
E
F
G
H
J
K
L
M

GW

FRONT DOOR GLASS AND REGULATOR

FRONT DOOR GLASS AND REGULATOR

PFP:80300

Removal and Installation

EIS009Z1

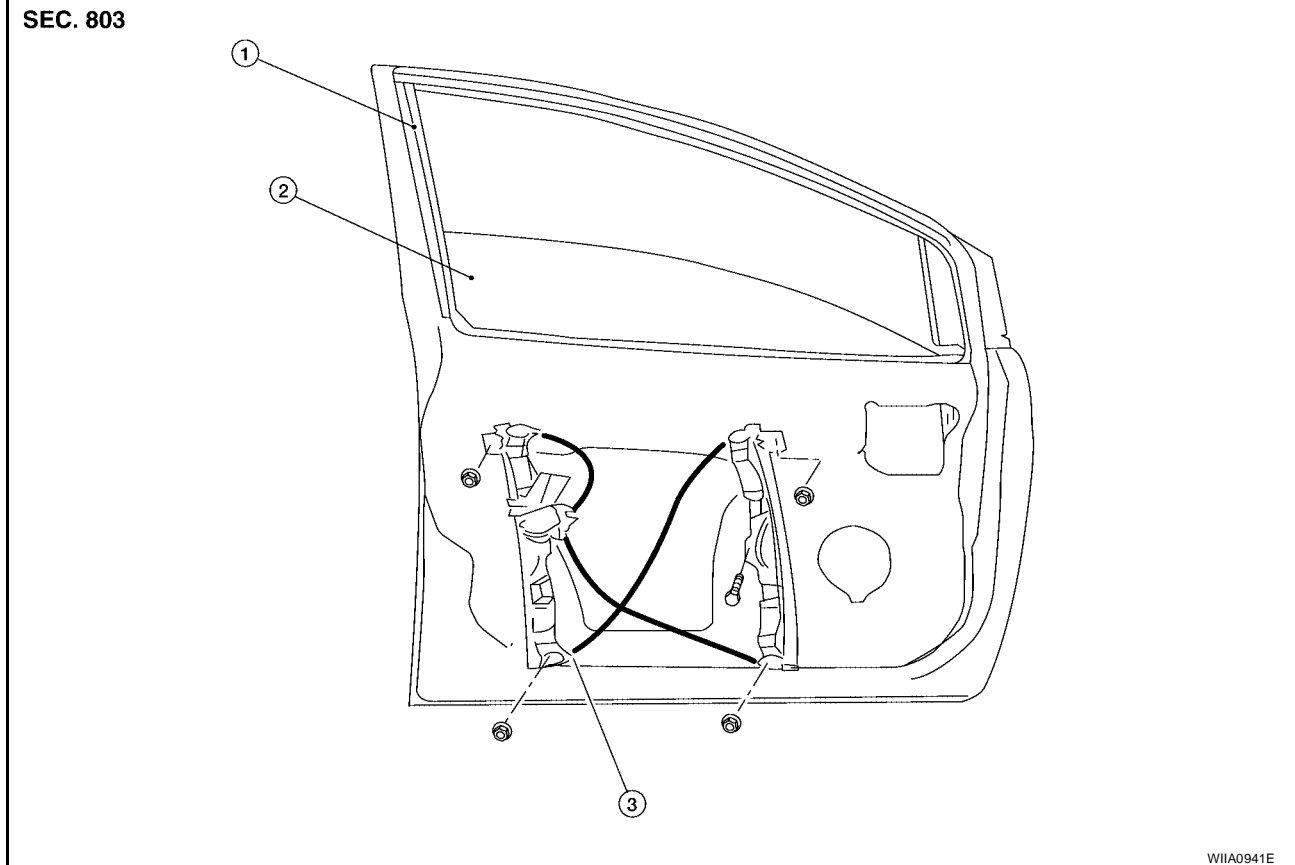

1. Door glass run

2. Door glass

3. Front door glass regulator assembly

FRONT DOOR GLASS

Removal

1. Remove the front door speaker. Refer to [AV-71, "FRONT DOOR SPEAKER"](#) .
2. Remove the hole cover over rear glass bolt.
3. Temporarily reconnect the power window switch.
4. Operate the power window main switch to raise/lower the door window until the glass bolts can be seen.
5. Remove the inside seal.
6. Remove the glass bolts.
7. While holding the front door glass, raise it at the rear end and pull the glass out of the sash toward the outside of the door.

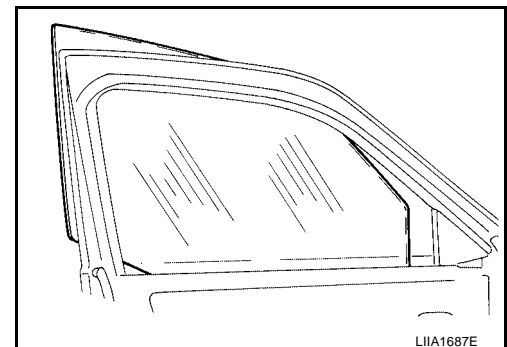

Installation

Installation is in the reverse order of removal.

Glass bolts : 6.1 N·m (0.62 kg·m, 54 in·lb)

FRONT DOOR GLASS AND REGULATOR

Fitting Inspection

- Check that the glass is securely fit into the glass run groove.
- Lower the glass slightly [approximately 10 to 20 mm (0.39 to 0.79 in)] and check that the clearance to the sash is parallel. If the clearance between the glass and sash is not parallel, loosen the regulator bolts, guide rail bolts, and glass and guide rail bolts to correct the glass position.

FRONT DOOR GLASS REGULATOR

Removal

1. Remove the front door speaker. Refer to [AV-71, "FRONT DOOR SPEAKER"](#) .
2. Remove the hole cover over rear glass bolt.
3. Temporarily reconnect the power window switch.
4. Operate the power window main switch to raise/lower the door window until the glass bolts can be seen.
5. Remove the inside seal.
6. Remove the glass bolts.
7. Raise the front door glass and hold it in place with suitable tool.
8. Disconnect the harness connector from the regulator assembly.
9. Remove the bolts and the regulator assembly.

Disassembly And Assembly

Remove the regulator motor from the regulator assembly.

Inspection After Removal

Check the regulator assembly for the following items. If a malfunction is detected, replace or grease it.

- Wire wear
- Regulator deformation
- Grease condition for each sliding part

The arrows in the figure show the application points of the body grease.

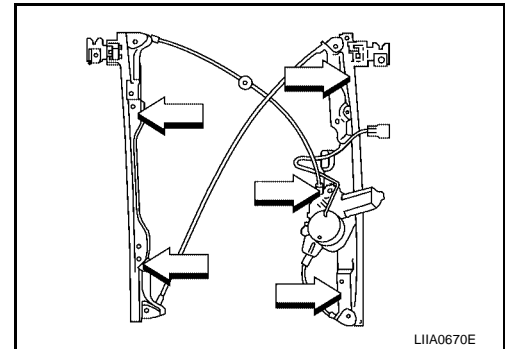

Installation

1. Install the regulator assembly.
2. Connect the harness connector to the regulator assembly.
3. Align the glass and install the glass bolts.

Glass bolts : 6.1 N·m (0.62 kg·m, 54 in·lb)

4. Reset the limit switch. Refer to [GW-59, "Setting of Limit Switch"](#) .
5. Install front door speaker. Refer to [AV-71, "FRONT DOOR SPEAKER"](#) .

SETTING AFTER INSTALLATION

Setting of Limit Switch

If any of the following work has been done, set the limit switch (integrated in the motor).

- Removal and installation of the regulator.
- Removal and installation of the motor from the regulator.
- Removal and installation of the glass.
- Removal and installation of the glass run.

Resetting

After installing each component, perform the following procedure to reset the limit switch.

FRONT DOOR GLASS AND REGULATOR

1. Raise the glass to the top position.
2. While pressing and holding the reset switch, lower the glass to the bottom position.
3. Release the reset switch. Verify that the reset switch returns to the original position, if not, pull the switch using suitable tool.
4. Raise the glass to the top position.

CAUTION:

Do not operate the glass automatically to raise the glass to the top position.

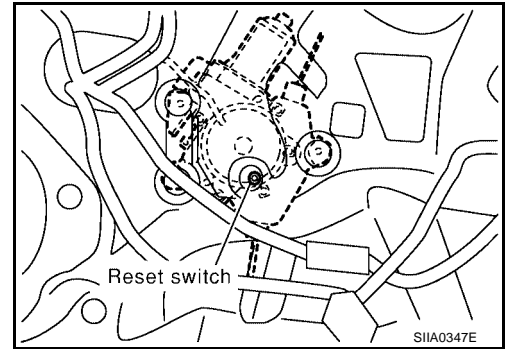

REAR DOOR GLASS AND REGULATOR

REAR DOOR GLASS AND REGULATOR

PFP:82300

Removal and Installation

EIS009ZJ

SEC. 823

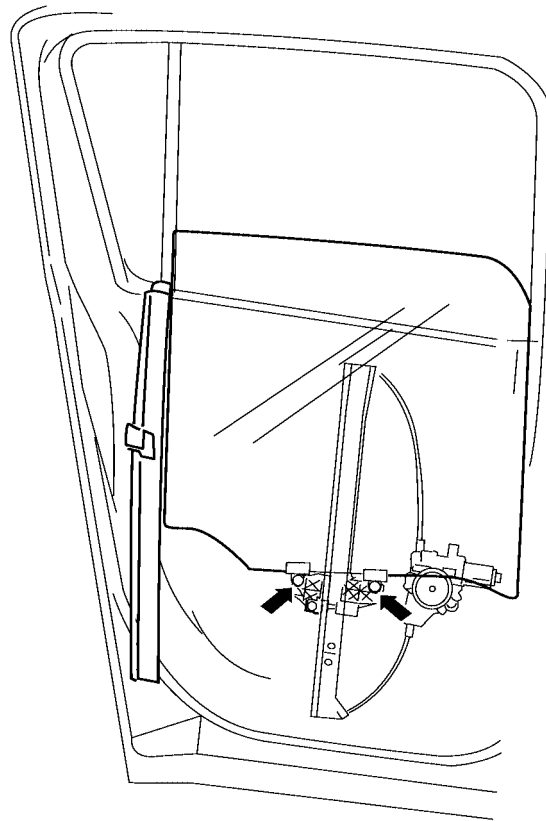

WIIA0942E

REAR DOOR GLASS

Removal

1. Remove the rear door finisher. Refer to [EI-29, "REAR DOOR"](#).
2. Temporarily reconnect the power window switch.
3. Operate the power window switch to raise/lower the door window until the glass bolts can be seen.
4. Remove the inside seal.
5. Remove the glass run from the partition glass.
6. Remove the partition sash bolt (lower) and screw (upper) to remove the sash.
7. Remove the glass bolts and glass.

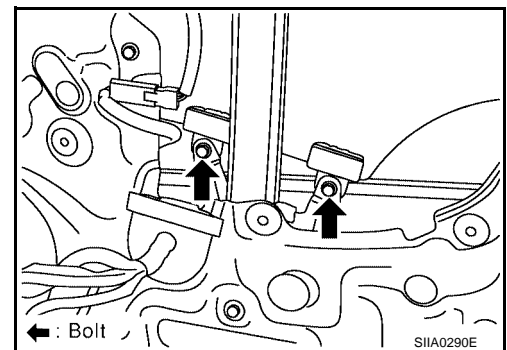

Installation

Installation is in the reverse order of removal.

Glass bolts : 6.1 N-m (0.62 Kg-m, 54 in-lb)

Fitting Inspection

- Check that the glass is securely fit into the glass run groove.
- Lower the glass slightly [approximately 10 to 20 mm (0.39 to 0.79 in)], and check that the clearance to the sash is parallel. If the clearance between the glass and sash is not parallel, loosen the regulator bolts, guide rail bolts, and glass and carrier plate bolts to correct the glass position.

A
B
C
D
E
F
G
H
GW
J
K
L
M

REAR DOOR GLASS AND REGULATOR

REAR DOOR GLASS REGULATOR

Removal

1. Remove the rear door finisher. Refer to [EI-29, "REAR DOOR"](#).
2. Temporarily reconnect the power window switch.
3. Operate the power window switch to raise/lower the door window until the glass bolts can be seen.
4. Remove the inside seal.
5. Remove the glass bolts.
6. Raise the glass and hold in place with suitable tool.

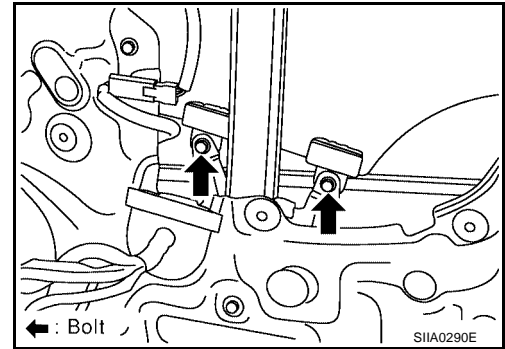

7. Remove the bolts, and the regulator and guide channel.
8. Disconnect the connector from the regulator assembly.

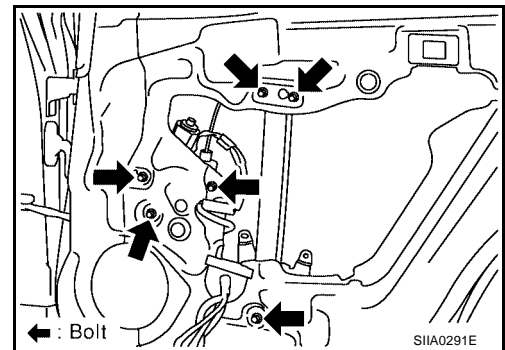

Inspection after removal

Check the regulator assembly for the following items. If a malfunction is detected, replace or grease it.

- Gear wear
- Regulator deformation
- Spring damage
- Grease condition for each sliding part

Installation

1. Connect the harness connector to the regulator assembly and install the regulator and guide channel.

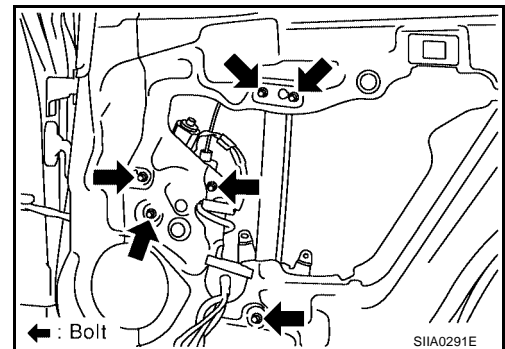

REAR DOOR GLASS AND REGULATOR

2. Install the glass from outside to ensure that it is in both the front and rear glass channels. Tighten glass bolts to the specified torque.

Glass bolts : 6.1 N·m (0.62 kg-m, 54 in-lb)

3. Install the inside seal.
4. Install the rear door finisher. Refer to [EI-29, "REAR DOOR"](#).

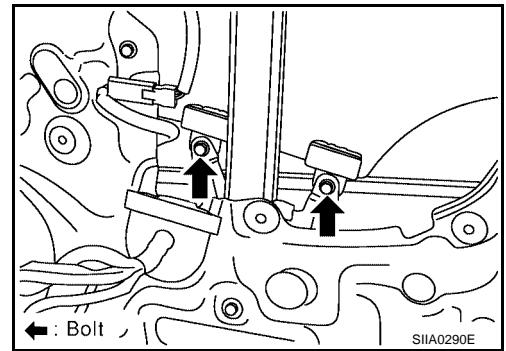

A

B

C

D

E

F

G

H

GW

J

K

L

M

SIDE WINDOW GLASS

SIDE WINDOW GLASS

PFP:83300

Removal and Installation (without Rear Power Vent Windows)

EIS009ZK

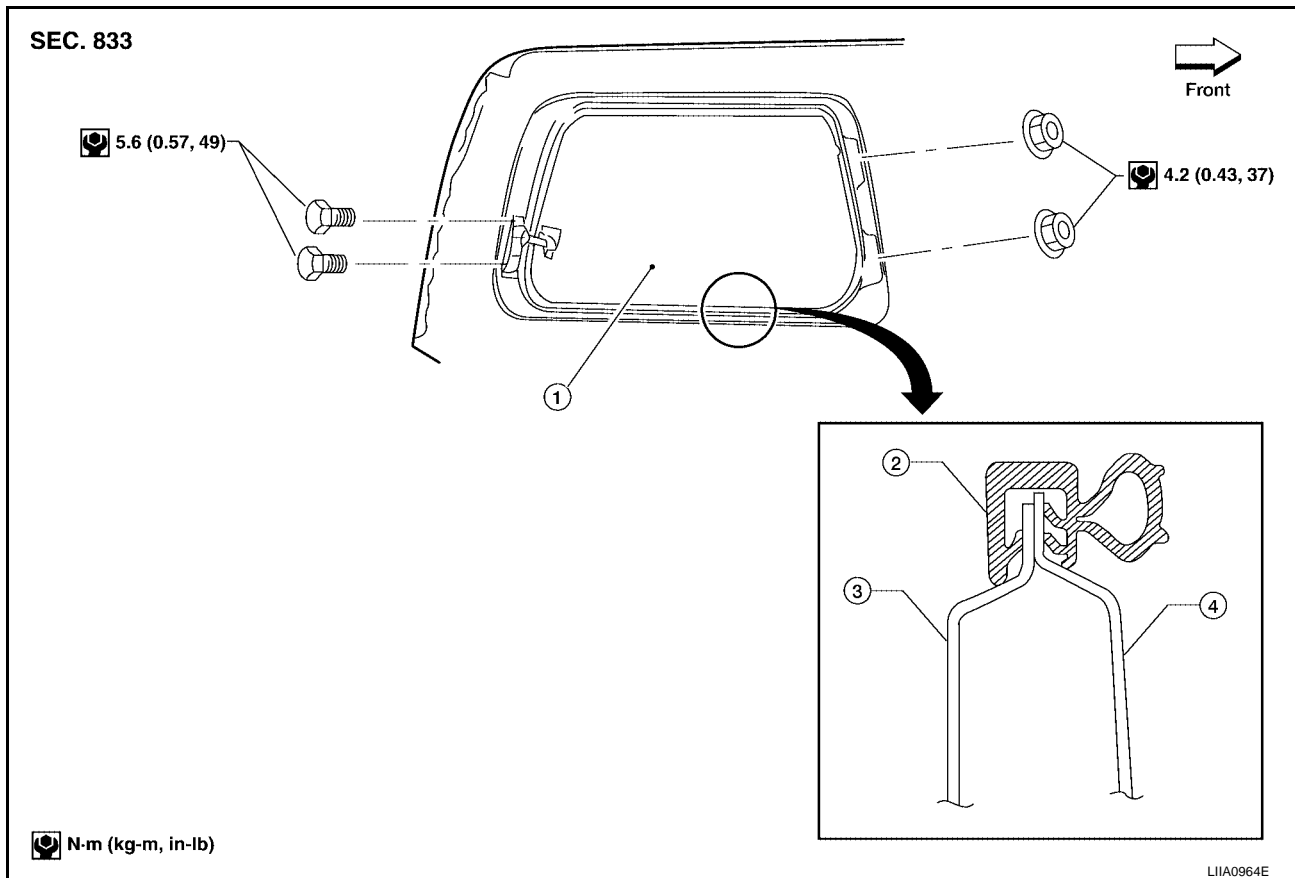

1. Rear side window glass
2. Weatherstrip
3. Inner panel
4. Outer panel

REMOVAL

1. Remove the rear lower finisher. Refer to [EI-31, "BODY SIDE TRIM"](#) .
2. Remove the rear pillar upper finisher. Refer to [EI-31, "BODY SIDE TRIM"](#) .
3. Remove the rear side window latch bolts.
4. Remove the rear side window nuts.

INSTALLATION

Installation should be performed in the reverse procedure of removal.

- Install the glass from outside to insure that it is even with the top and bottom of the opening.

SIDE WINDOW GLASS

Removal and Installation (with Rear Power Vent Windows)

EIS009ZL

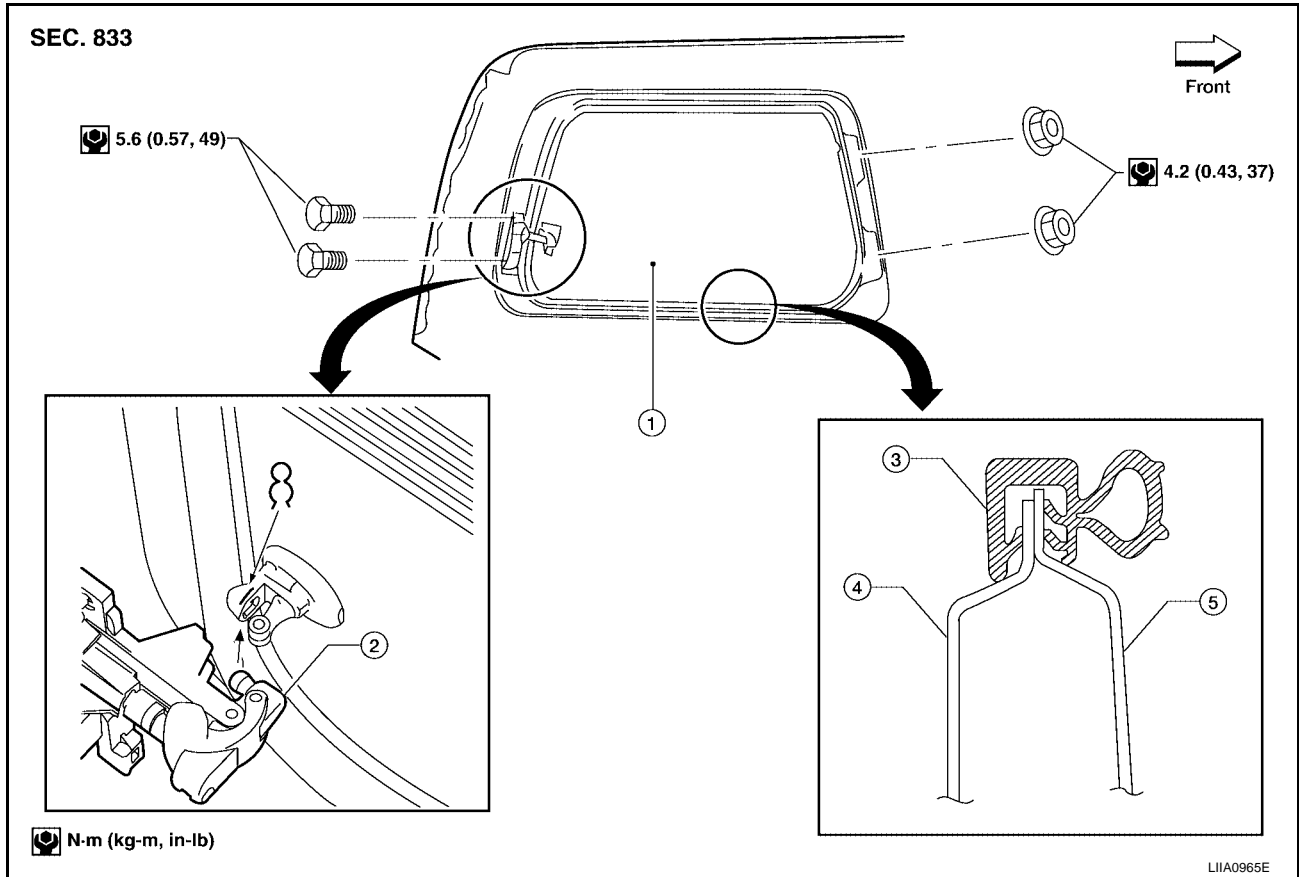

1. Rear side window glass
2. Rear side window motor
3. Weatherstrip
4. Inner panel
5. Outer panel

REMOVAL

1. Remove the rear lower finisher. Refer to [EI-31, "BODY SIDE TRIM"](#).
2. Remove the rear pillar upper finisher. Refer to [EI-31, "BODY SIDE TRIM"](#).
3. Disconnect the rear side window motor harness.
4. Remove the rear side window motor bolts.
5. Remove the rear side window nuts.

INSTALLATION

Installation should be performed in the reverse procedure of removal.

- Install the glass from outside to insure that it is even with the top and bottom of the opening.

A
B
C
D
E
F
G
H
GW
J
K
L
M

INSIDE MIRROR

PF9:96321

INSIDE MIRROR

Wiring Diagram — I/MIRR —

EIS0092M

GW-I/MIRR-01

EC: WITH AUTO DIMMING OUTSIDE MIRRORS

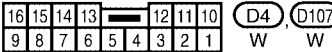
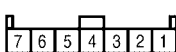
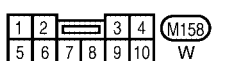
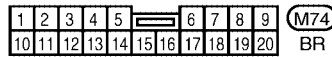
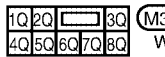
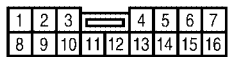
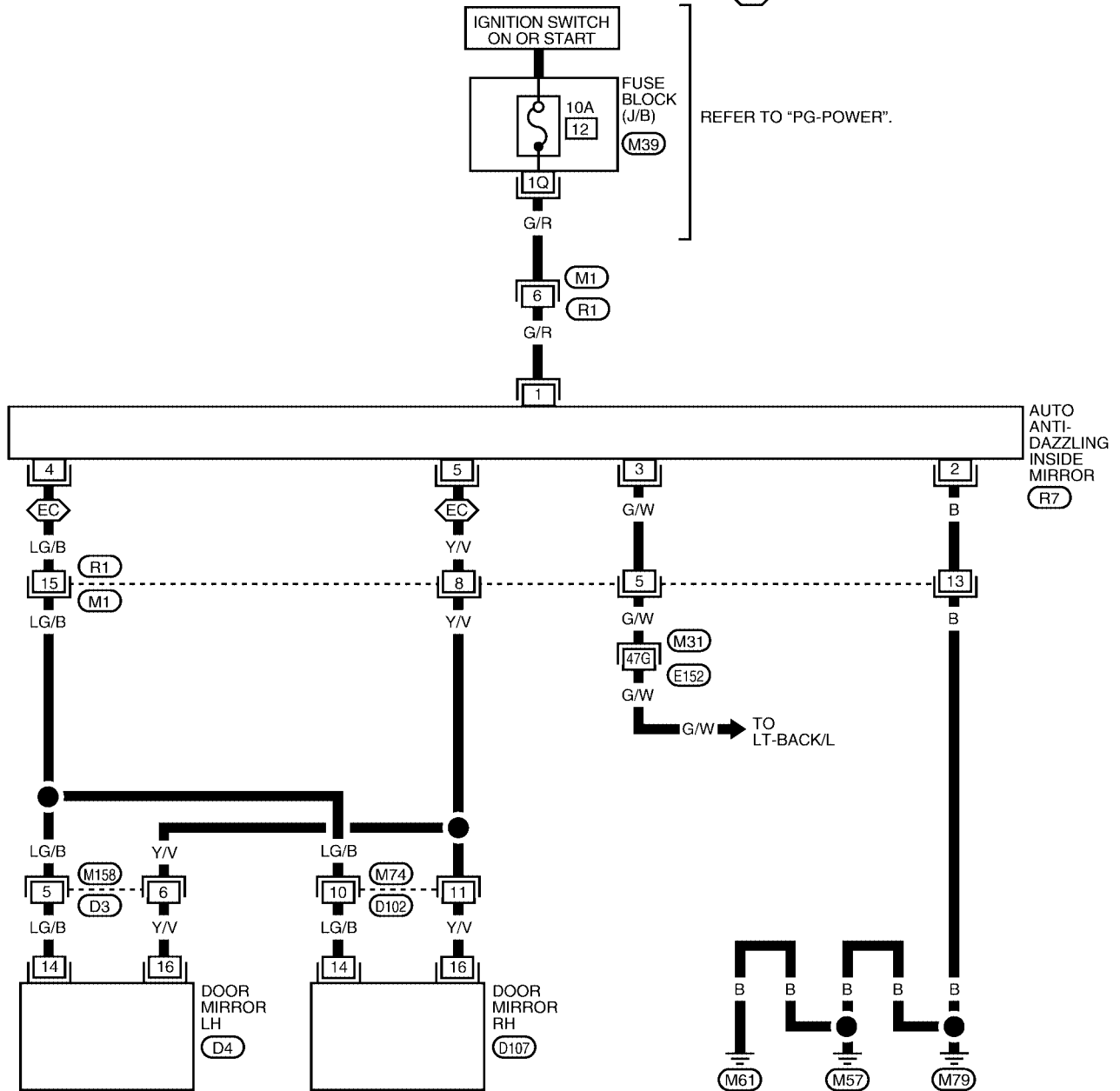

REFER TO THE FOLLOWING.

M31 - SUPER MULTIPLE JUNCTION (SMJ)

WIIWA2027E

INSIDE MIRROR

EIS009ZN

Removal and Installation INSIDE MIRROR

1. Remove inside mirror finisher.
2. Slide the mirror upward to remove.
3. Disconnect the connector.

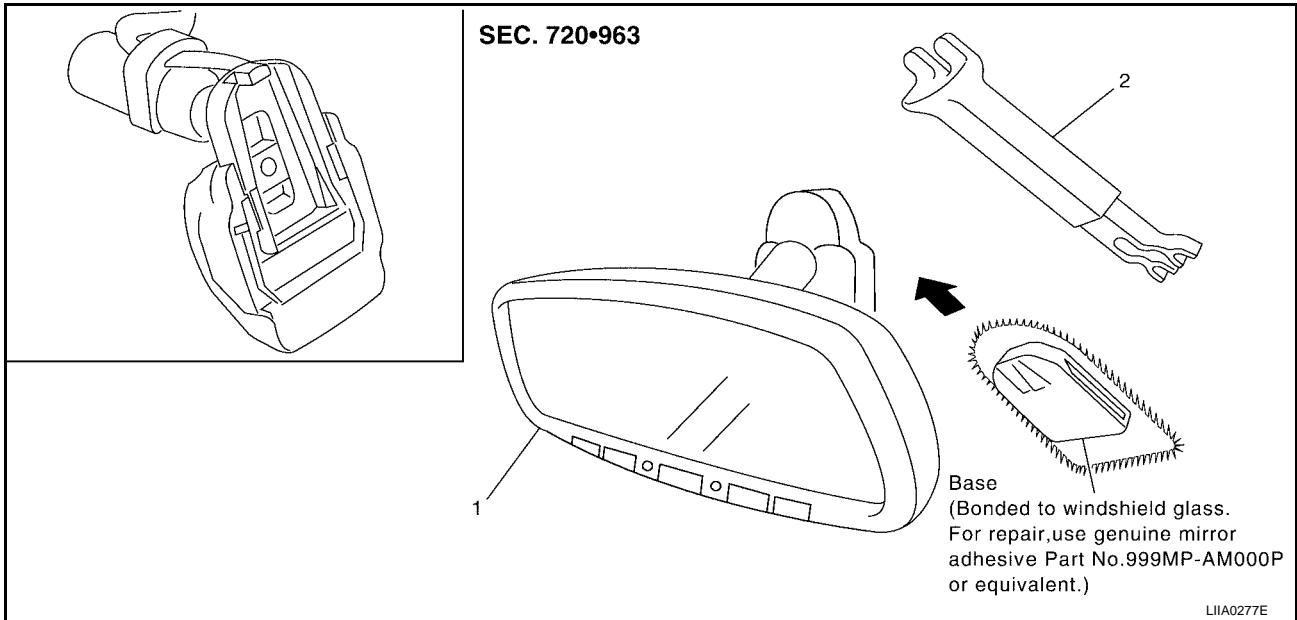

1. Inside mirror

2. Inside mirror finisher

A
B
C
D
E
F
G
H

GW

J
K
L
M

REAR WINDOW DEFOGGER

REAR WINDOW DEFOGGER

PF2:25350

Component Parts and Harness Connector Location

EIS00920

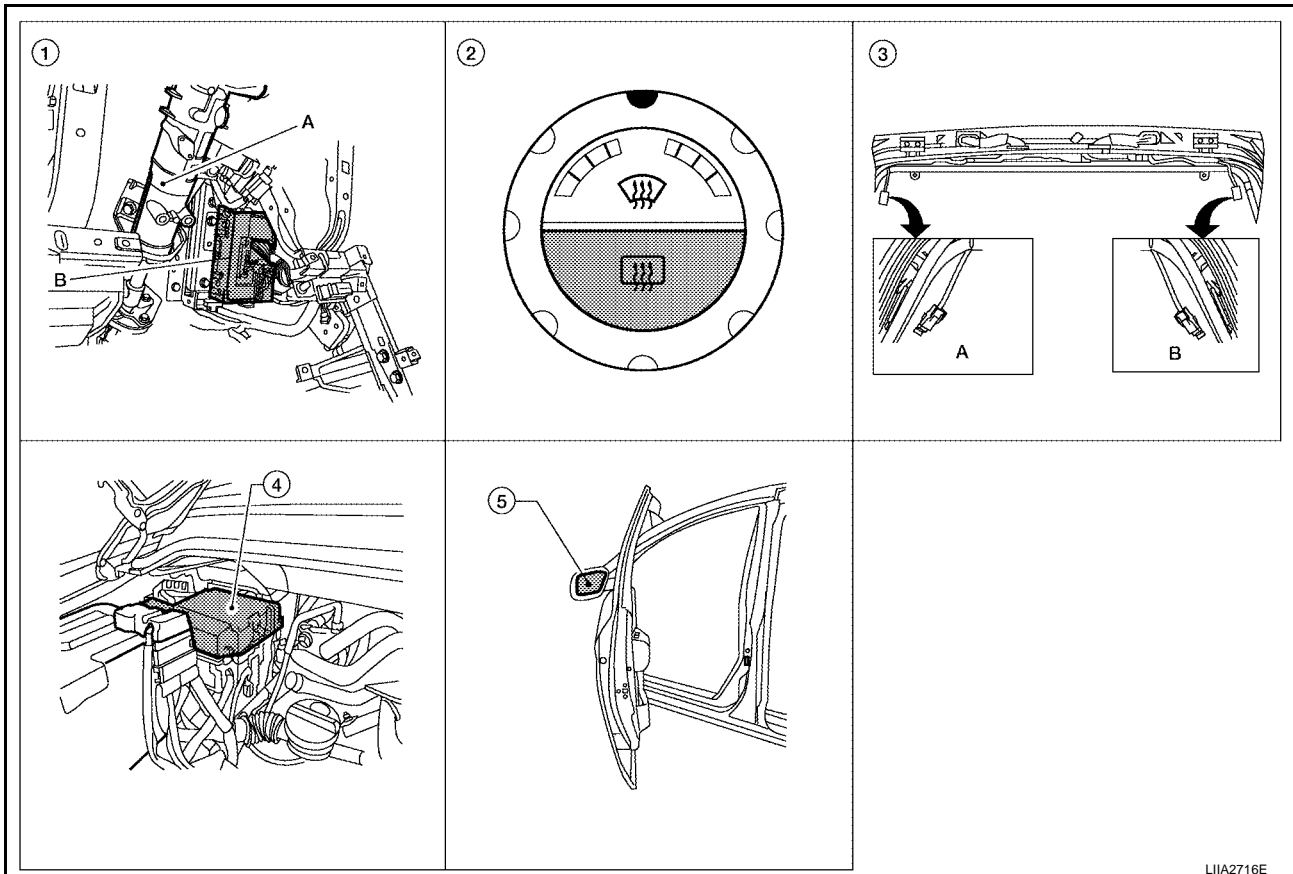

LIA2716E

1. A. Steering column
B. BCM M18, M20 (view with instrument panel removed)

2. Front air control M49, M50

3. A. Rear window defogger ground connector D604
B. Rear window defogger connector D406

4. IPDM E/R E120, E122, E124

5. Door mirror LH (door mirror defogger) D4
Door mirror RH (door mirror defogger) D107

REAR WINDOW DEFOGGER

EIS009ZP

System Description

The rear window defogger system is controlled by BCM (body control module) and IPDM E/R (intelligent power distribution module engine room).

The rear window defogger operates only for approximately 15 minutes.

Power is supplied at all times

- through 15A fuses (No. 46 and 47, located in the IPDM E/R)
- to rear window defogger relay
- through 15A fuse (No. 43 located in the IPDM E/R)
- to heated mirror relay
- through 50A fusible link (letter f , located in the fuse and fusible link box)
- to BCM terminal 70.

With the ignition switch turned to ON or START position, power is supplied

- through ignition switch
- to rear window defogger relay (located in the IPDM E/R)
- through 10A fuse (No. 59, located in the fuse and relay box)
- to BCM terminal 38
- through 10A fuse [No. 8, located in the fuse block (J/B)]
- to front air control terminal 14.

Ground is supplied

- to BCM terminal 67
- to front air control terminal 1
- through body grounds M57, M61 and M79
- to IPDM E/R terminals 38 and 60
- through body grounds E15 and E24.

When front air control (rear window defogger switch) is turned to ON, ground is supplied

- to BCM terminal 9
- through front air control terminal 11
- through front air control terminal 1
- through body grounds M57, M61 and M79.

Then rear window defogger switch is illuminated.

Then BCM recognizes that rear window defogger switch is turned to ON.

Then it sends rear window defogger switch signals to IPDM E/R and display control unit (with navigation) via CAN communication (CAN-H, CAN-L).

When display control unit (with navigation) receives rear window defogger switch signals, and display on the screen.

When IPDM E/R receives rear window defogger switch signals, ground is supplied

- to rear window defogger relay (located in the IPDM E/R)
- through IPDM E/R terminal 38
- through IPDM E/R terminal 59
- through body grounds E15 and E24

and then rear window defogger relay is energized.

With power and ground supplied, rear window defogger filaments heat and defog the rear window.

When rear window defogger relay is turned to ON, power is supplied

- through heated mirror relay (located in the IPDM E/R)
- through IPDM E/R terminal 23
- to door mirror defogger (LH and RH) terminal 10.

Door mirror defogger (LH and RH) is grounded through body grounds M57, M61 and M79.

With power and ground supplied, rear window defogger filaments heat and defog the rear window and door mirror defogger filaments heat and defog the mirror.

A

B

C

D

E

F

G

H

GW

J

K

L

M

REAR WINDOW DEFOGGER

CAN Communication System Description

EIS009ZQ

Refer to [LAN-4, "SYSTEM DESCRIPTION"](#) .

REAR WINDOW DEFOGGER

Schematic

EIS0092R

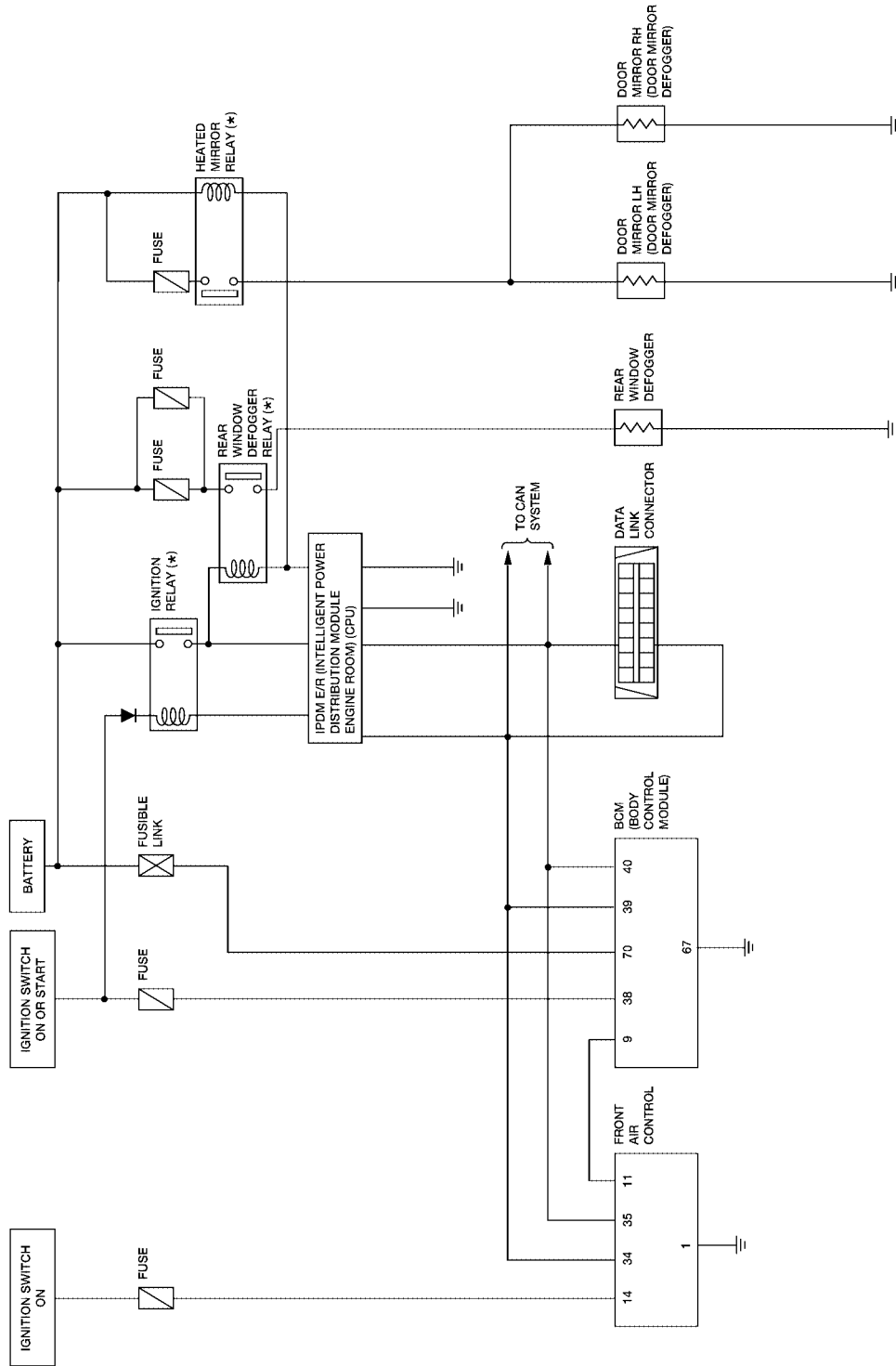

* : THIS RELAY IS BUILT INTO THE IPDM E/R (INTELLIGENT POWER DISTRIBUTION MODULE ENGINE ROOM)

A
B
C
D
E
F
G
H
I
J
K
L
M

GW

REAR WINDOW DEFOGGER

Wiring Diagram — DEF —

EIS0092S

GW-DEF-01

— : DATA LINE

REFER TO "PG-POWER".

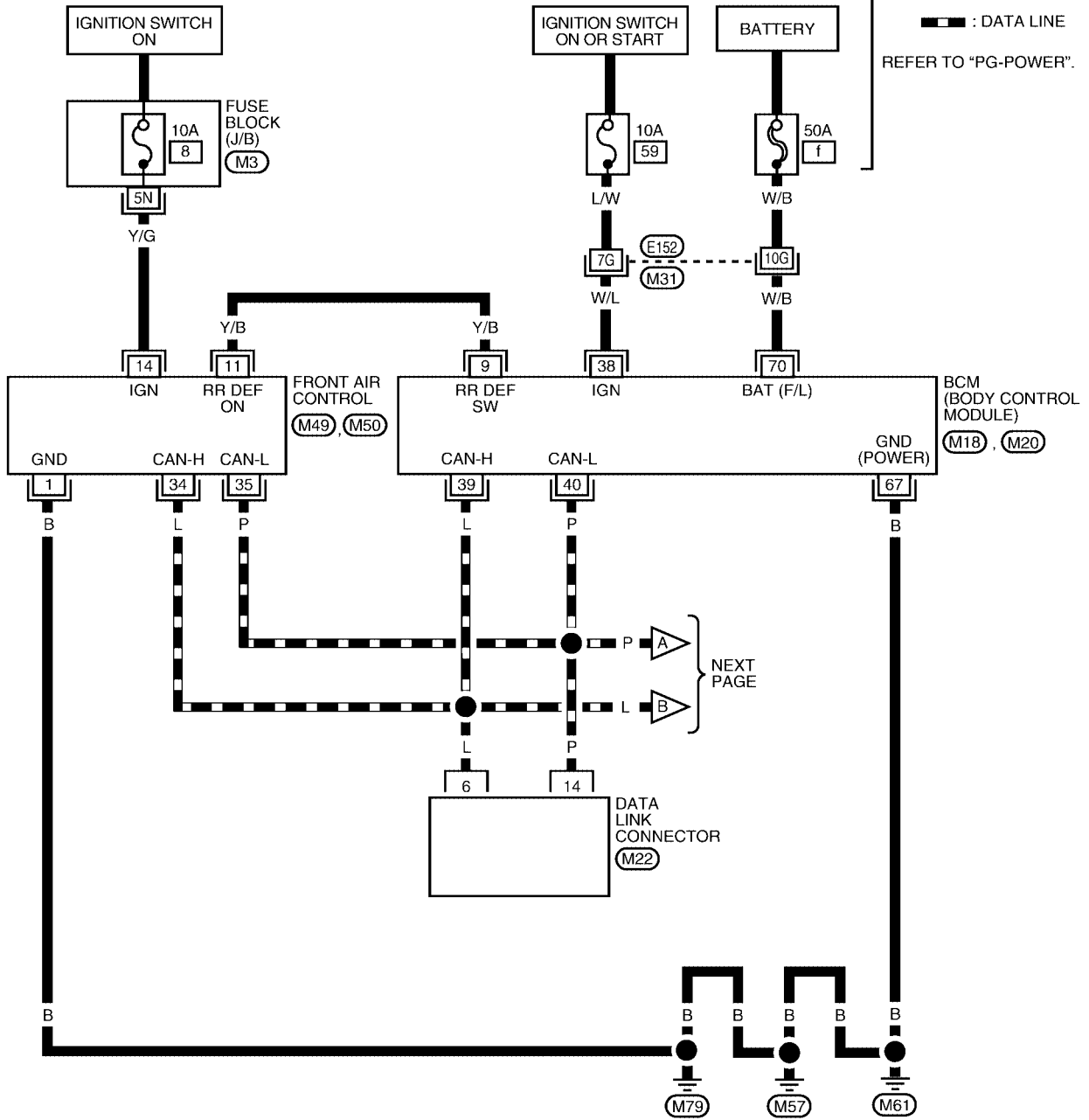

REFER TO THE FOLLOWING.

(M31) - SUPER MULTIPLE JUNCTION (SMJ)

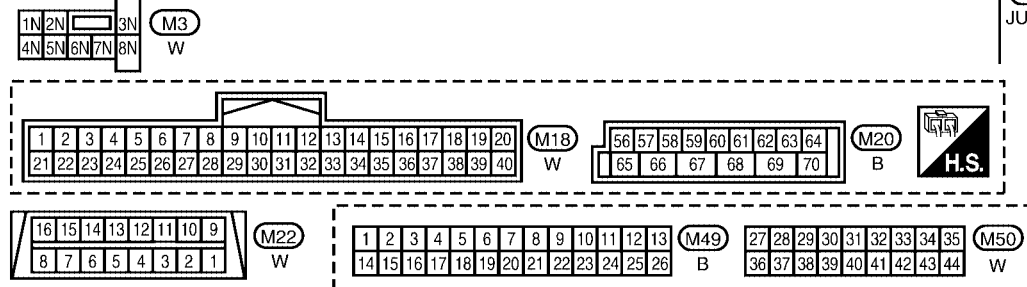

WIWA0732E

REAR WINDOW DEFOGGER

GW-DEF-02

— : DATA LINE

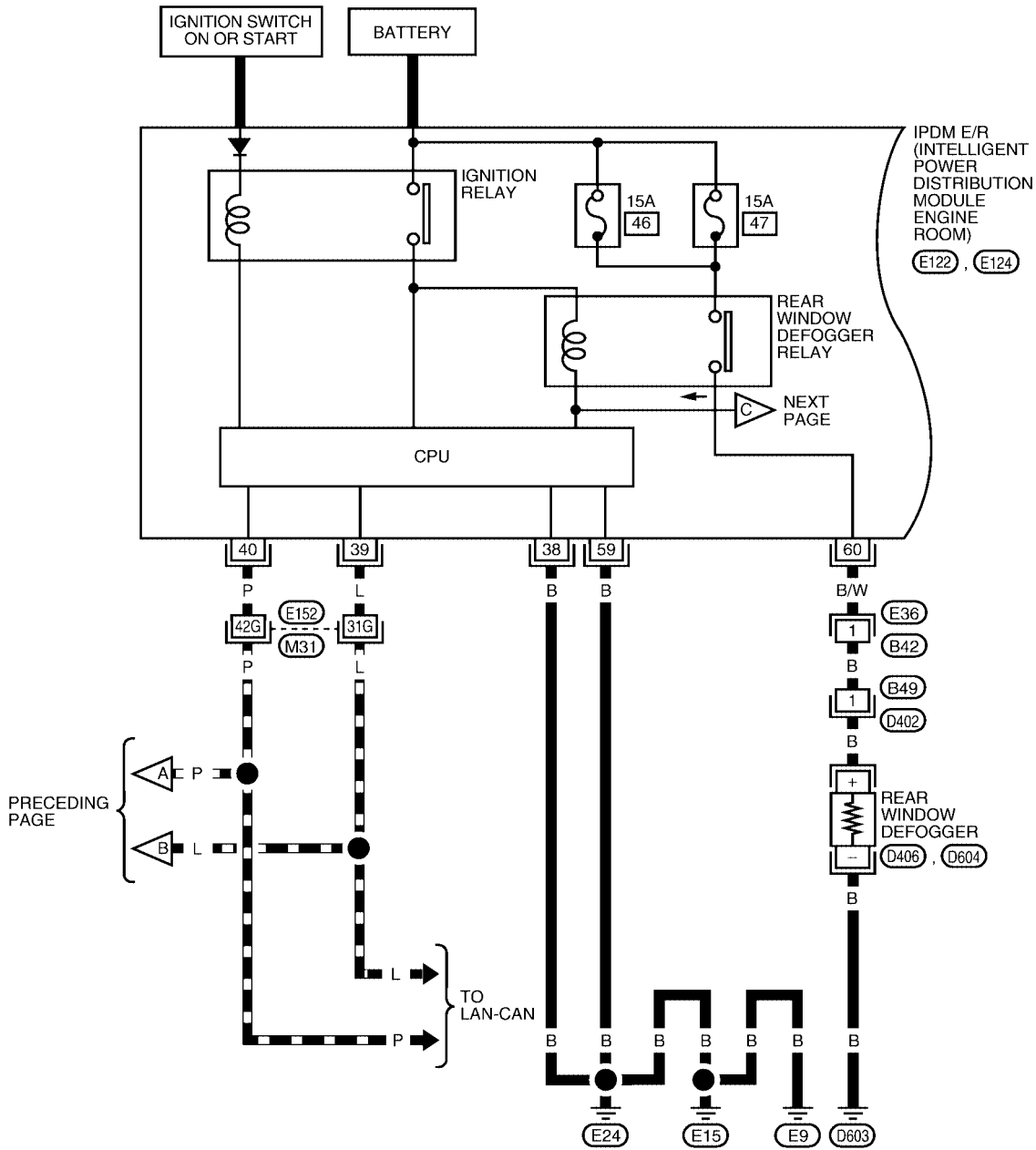

A

B

C

D

E

F

G

H

GW

J

K

L

M

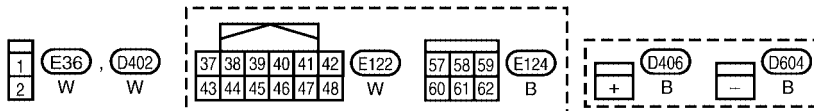

REFER TO THE FOLLOWING.
 (M31) - SUPER MULTIPLE JUNCTION (SMJ)

WIWA2009E

REAR WINDOW DEFOGGER

Terminals and Reference Values for BCM

EIS009ZT

Refer to [BCS-12, "Terminals and Reference Values for BCM"](#) .

Terminals and Reference Values for IPDM E/R

EIS009ZU

Refer to [AV-30, "Terminals and Reference Value for Audio Unit for Base System"](#) .

Work Flow

EIS009ZV

1. Check the symptom and customer's requests.
2. Understand the outline of system. Refer to [GW-69, "System Description"](#) .
3. According to the trouble diagnosis chart, repair or replace the cause of the malfunction. Refer to [GW-75, "Trouble Diagnoses Symptom Chart"](#) .
4. Does rear window defogger operate normally? YES: GO TO 5, NO: GO TO 3.
5. Inspection End.

CONSULT-II Function (BCM)

EIS009ZW

CONSULT-II can display each diagnostic item using the diagnostic test modes shown following.

BCM diagnostic test item	Diagnostic mode	Content
Inspection by part	WORK SUPPORT	Supports inspections and adjustments. Commands are transmitted to the BCM for setting the status suitable for required operation, input/output signals are received from the BCM and received data is displayed.
	DATA MONITOR	Displays BCM input/output data in real time.
	ACTIVE TEST	Operation of electrical loads can be checked by sending drive signal to them.
	SELF-DIAG RESULTS	Displays BCM self-diagnosis results.
	CAN DIAG SUPPORT MNTR	The results of transmit/receive diagnosis of CAN communication can be read.
	ECU PART NUMBER	BCM part number can be read.
	CONFIGURATION	Performs BCM configuration read/write functions.

CONSULT-II START PROCEDURE

Refer to [GI-38, "CONSULT-II Start Procedure"](#) .

DATA MONITOR

Display Item List

Monitor item "Operation"	Content
REAR DEF SW	"ON/OFF" Displays "Press (ON)/others (OFF)" status determined with the rear window defogger switch.
IGN ON SW	"ON/OFF" Displays "IGN (ON)/OFF" status determined with the ignition switch signal.

ACTIVE TEST

Display Item List

Test item	Content
REAR WINDOW DEFOGGER	Gives a signal to the rear window defogger to activate it.

Trouble Diagnoses Symptom Chart

EIS009ZX

Make sure other systems using the signal of the following systems operate normally.

Symptom	Diagnoses / Service procedure	Refer to page
Rear window defogger and door mirror defoggers do not operate.	1. BCM power supply and ground circuit check	BCS-17
	2. IPDM E/R auto active test check	PG-22
	3. Rear window defogger switch circuit check	GW-76
	4. Rear window defogger power supply circuit check	GW-77
	5. Replace IPDM E/R	PG-30

REAR WINDOW DEFOGGER

Symptom	Diagnoses / Service procedure	Refer to page
Rear window defogger does not operate but both of door mirror defoggers operate.	1. Rear window defogger power supply circuit check	GW-77
	2. Rear window defogger circuit check	GW-78
	3. Filament check	GW-85
	4. Replace IPDM E/R	PG-30
Both door mirror defoggers do not operate but rear window defogger operates.	1. Door mirror defogger power supply circuit check	GW-78 , GW-80
	2. Replace IPDM E/R	PG-30
Door mirror LH (door mirror defogger) does not operate.	1. Door mirror LH (door mirror defogger) circuit check	GW-81 , GW-82
Door mirror RH (door mirror defogger) does not operate.	1. Door Mirror RH (door mirror defogger) circuit check	GW-83 , GW-84
Rear window defogger switch does not light, and rear window defogger is not shown on the display control unit (with navigation), but rear window defogger operates.	1. Rear window defogger signal check	GW-85

BCM Power Supply and Ground Circuit Check

EIS009ZY

Refer to [BCS-17](#), "BCM Power Supply and Ground Circuit Check".

Rear Window Defogger Switch Circuit Check

EIS009ZZ

1. CHECK REAR WINDOW DEFOGGER SWITCH OPERATION

Ⓛ With CONSULT-II

Check ("REAR DEF SW", "IGN ON SW") in DATA MONITOR mode with CONSULT-II.

When rear window defogger switch is turned to ON

REAR DEF SW: ON

When ignition switch is turned to ON

IGN ON SW: ON

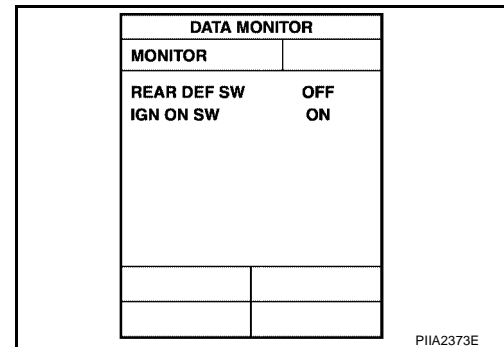

⊗ Without CONSULT-II

1. Turn ignition switch ON.
2. Check voltage between BCM connector and ground.

Connector	Terminal		Condition	Voltage (V) (Approx.)
	(+)	(-)		
M18	9	Ground	Rear window defogger switch is ON.	0
			Rear window defogger switch is OFF.	5

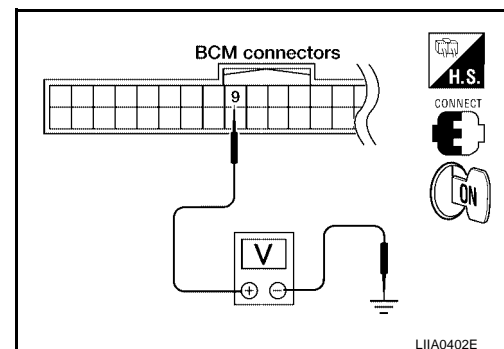

OK or NG

- OK >> Rear window defogger switch check is OK.
 NG >> GO TO 2.

REAR WINDOW DEFOGGER

2. CHECK REAR WINDOW DEFOGGER SWITCH CIRCUIT HARNESS CONTINUITY

1. Turn ignition switch OFF.
2. Disconnect BCM and front air control.
3. Check continuity between BCM connector M18 terminal 9 and front air control connector M49 terminal 11.

9 - 11 : Continuity should exist.

4. Check continuity between BCM connector M18 terminal 9 and ground

9 - Ground : Continuity should not exist.

OK or NG

- OK >> GO TO 3.
- NG >> Repair or replace harness.

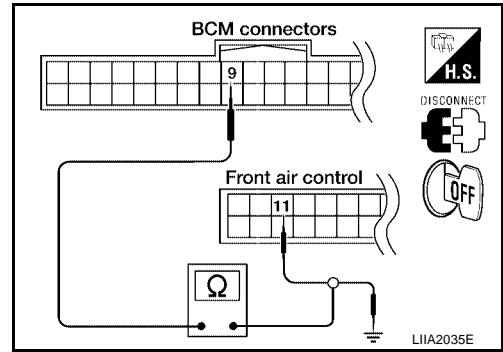

3. CHECK BCM OUTPUT SIGNAL

1. Connect BCM.
2. Turn ignition switch ON.
3. Check voltage between BCM connector M18 terminal 9 and ground.

9 - Ground : Approx. 5V

OK or NG

- OK >> Replace front air control. Refer to [ATC-193, "FRONT AIR CONTROL"](#).
- NG >> Replace BCM. Refer to [BCS-26, "Removal and Installation"](#).

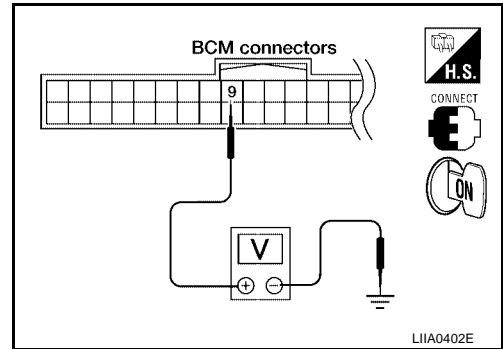

Rear Window Defogger Power Supply Circuit Check

EIS00A00

1. CHECK FUSE

Check if any of the following fuses in the IPDM E/R are blown.

COMPONENT PARTS	AMPERE	FUSE NO.
IPDM E/R	15A	46
IPDM E/R	15A	47

OK or NG

- OK >> GO TO 2.
- NG >> If fuse is blown, be sure to eliminate cause of malfunction before installing new fuse.

2. CHECK REAR WINDOW DEFOGGER RELAY OUTPUT SIGNAL

Check voltage between IPDM E/R connector E124 terminal 60 and ground.

60 - Ground : Battery voltage

OK or NG

- OK >> Replace IPDM E/R. Refer to [PG-30, "Removal and Installation of IPDM E/R"](#).
- NG >> Repair or replace harness.

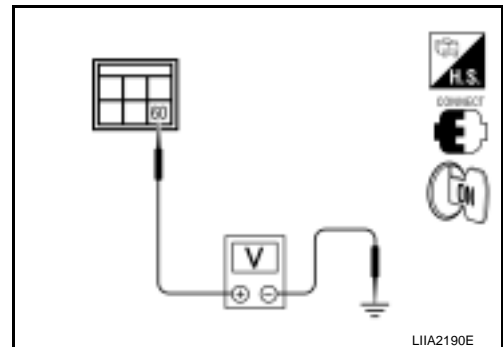

REAR WINDOW DEFOGGER

EIS00A01

Rear Window Defogger Circuit Check

1. CHECK REAR WINDOW DEFOGGER POWER SUPPLY CIRCUIT

1. Turn ignition switch OFF.
2. Disconnect rear window defogger.
3. Turn ignition switch ON.
4. Check voltage between rear window defogger connector D406 terminal + and ground.

Connector	Terminal		Condition	Voltage (V) (Approx.)
	(+)	(-)		
D406	+	Ground	Rear window defogger switch ON.	Battery voltage
			Rear window defogger switch OFF.	0

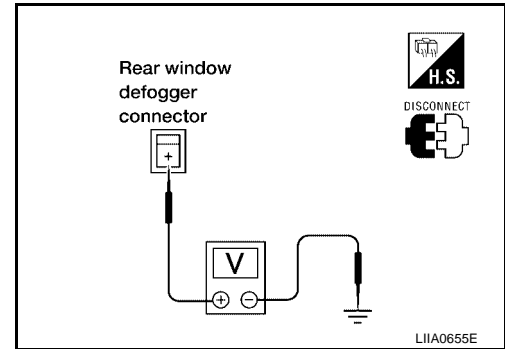

OK or NG

- OK >> GO TO 2.
 NG >> Repair or replace harness.

2. CHECK REAR WINDOW DEFOGGER GROUND CIRCUIT

1. Turn ignition switch OFF.
2. Check continuity between rear window defogger connector D604 terminal - and ground.

- - Ground : Continuity should exist.

OK or NG

- OK >> Check filament. Refer to [GW-85, "Filament Check"](#).
- If filament is OK.
Check the condition of the harness and the connector.
 - If filament is NG.
Repair filament.
- NG >> Repair or replace harness.

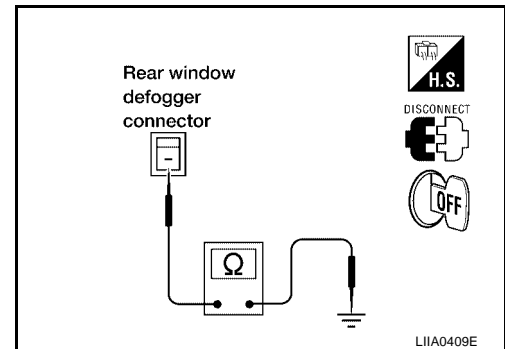

Door Mirror Defogger Power Supply Circuit Check (Without Automatic Drive Positioner)

EIS00A02

1. CHECK FUSE

Check if the following fuse in the IPDM E/R is blown.

COMPONENT PARTS	AMPERE	FUSE NO.
IPDM E/R	15A	43

OK or NG

- OK >> GO TO 2.
 NG >> If fuse is blown, be sure to eliminate cause of malfunction before installing new fuse.

REAR WINDOW DEFOGGER

2. CHECK DOOR MIRROR DEFOGGER POWER SUPPLY CIRCUIT 2

Check voltage between IPDM E/R connector and ground.

Connector	Terminal		Condition	Voltage (V) (Approx.)
	(+)	(-)		
E120	23	Ground	Rear window defogger switch ON	Battery voltage
			Rear window defogger switch OFF	0

OK or NG

OK >> GO TO 3.

NG >> Replace IPDM E/R. Refer to [PG-30, "Removal and Installation of IPDM E/R"](#).

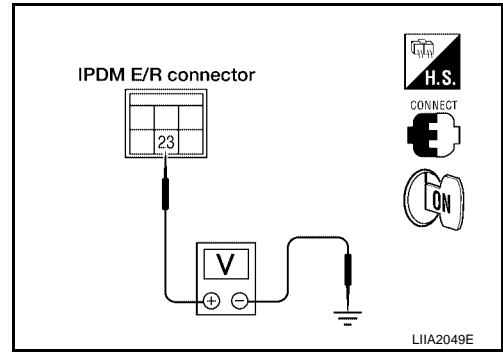

3. CHECK DOOR MIRROR DEFOGGER CIRCUIT

1. Turn ignition switch OFF.
2. Disconnect IPDM E/R and door mirror LH or RH.
3. Check continuity between IPDM E/R connector E120 terminal 23 and door mirror connector D4 (LH) or D107 (RH) terminal 4.

23 - 4 : Continuity should exist.

OK or NG

OK >> GO TO 4.

NG >> Repair or replace harness.

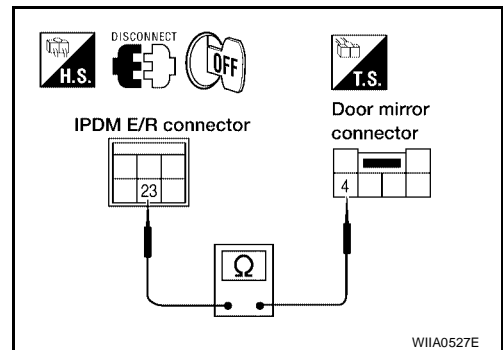

4. CHECK DOOR MIRROR DEFOGGER GROUND CIRCUIT

Check continuity between each door mirror connector D4 (LH) or D107 (RH) terminal 6 and ground.

6 - Ground : Continuity should exist.

OK or NG

OK >> GO TO 5.

NG >> Repair or replace harness.

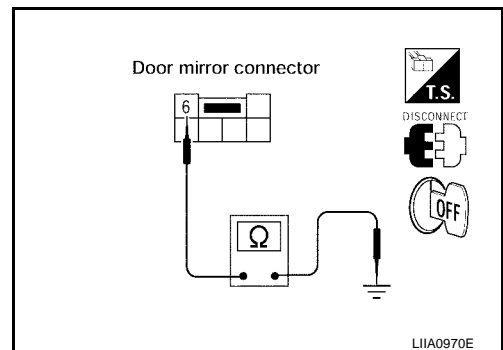

5. CHECK DOOR MIRROR DEFOGGER

Check continuity between each door mirror terminals 4 and 6.

4 - 6 : Continuity should exist.

OK or NG

OK >> Check the condition of the harness and the connector.

NG >> Replace malfunctioning door mirror LH or RH. Refer to [GW-90, "Door Mirror Assembly"](#).

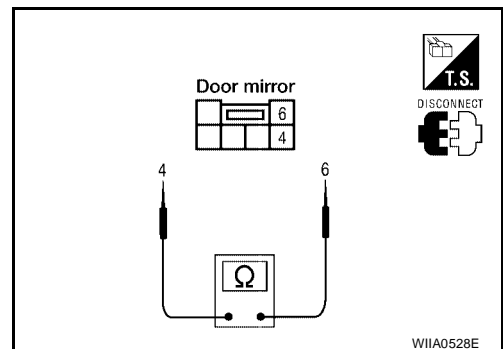

REAR WINDOW DEFOGGER

Door Mirror Defogger Power Supply Circuit Check (With Automatic Drive Positioner)

EIS00A03

1. CHECK FUSE

Check if the following fuse in the IPDM E/R is blown.

COMPONENT PARTS	AMPERE	FUSE NO.
IPDM E/R	15A	43

OK or NG

OK >> GO TO 2.

NG >> If fuse is blown, be sure to eliminate cause of malfunction before installing new fuse.

2. CHECK DOOR MIRROR DEFOGGER POWER SUPPLY CIRCUIT 2

1. Turn Ignition switch ON.
2. Check voltage between IPDM E/R connector and ground.

Connector	Terminal		Condition	Voltage (V) (Approx.)
	(+)	(-)		
E120	23	Ground	Rear window defogger switch ON	Battery voltage
			Rear window defogger switch OFF	0

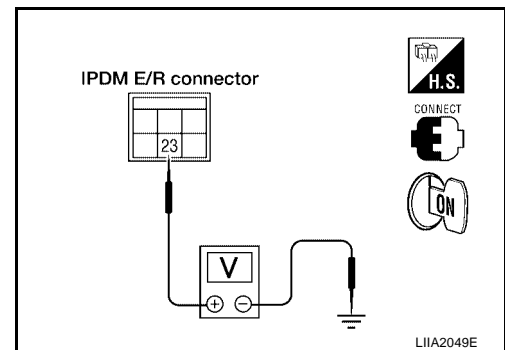

OK or NG

OK >> GO TO 3.

NG >> Replace IPDM E/R. Refer to [PG-30, "Removal and Installation of IPDM E/R"](#).

3. CHECK DOOR MIRROR DEFOGGER CIRCUIT

1. Turn ignition switch OFF.
2. Disconnect IPDM E/R and door mirror LH or RH.
3. Check continuity between IPDM E/R connector E120 terminal 23 and door mirror connector D4 (LH) or D107 (RH) terminal 10.

23 - 10 : Continuity should exist.

OK or NG

OK >> GO TO 4.

NG >> Repair or replace harness.

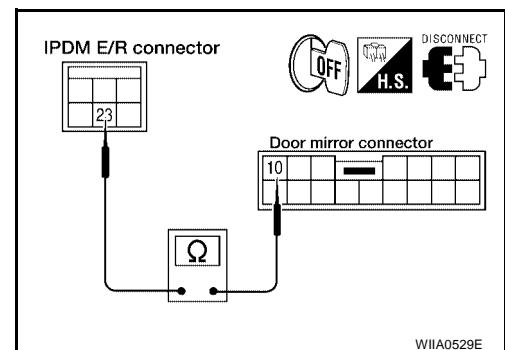

4. CHECK DOOR MIRROR DEFOGGER GROUND CIRCUIT

Check continuity between each door mirror connector D4 (LH) or D107 (RH) terminal 11 and ground.

11 - Ground : Continuity should exist.

OK or NG

OK >> GO TO 5.

NG >> Repair or replace harness.

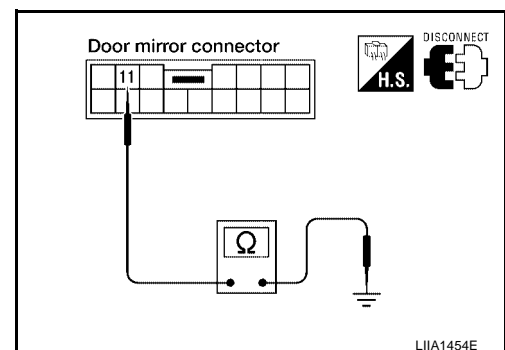

REAR WINDOW DEFOGGER

5. CHECK DOOR MIRROR DEFOGGER

Check continuity between each door mirror terminals 10 and 11.

10 - 11 : Continuity should exist.

OK or NG

- OK >> Check the condition of the harness and the connector.
- NG >> Replace malfunctioning door mirror LH or RH. Refer to [GW-90, "Door Mirror Assembly"](#) .

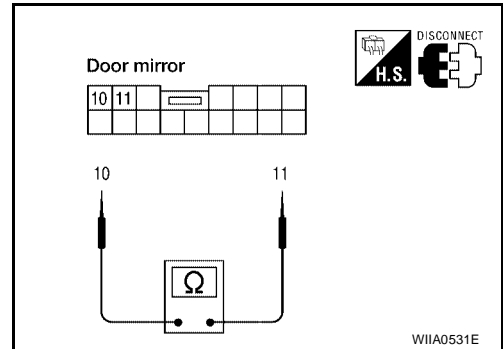

Door Mirror LH (Door Mirror Defogger) Circuit Check (Without Automatic Drive Positioner)

EIS00A04

1. CHECK DOOR MIRROR DEFOGGER POWER SUPPLY CIRCUIT

1. Turn ignition switch OFF.
2. Disconnect door mirror LH.
3. Turn ignition switch ON.
4. Check voltage between door mirror LH connector and ground.

Connector	Terminal		Condition	Voltage (V) (Approx.)
	(+)	(-)		
D4	4	Ground	Rear window defogger switch ON	Battery voltage
			Rear window defogger switch OFF	0

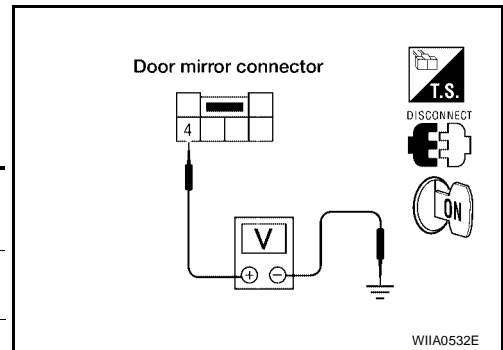

OK or NG

- OK >> GO TO 2.
- NG >> Repair or replace harness.

2. CHECK DOOR MIRROR DEFOGGER GROUND CIRCUIT

1. Turn ignition switch OFF.
2. Check continuity between door mirror LH connector D4 terminal 6 and ground.

6 - Ground : Continuity should exist.

OK or NG

- OK >> GO TO 3.
- NG >> Repair or replace harness.

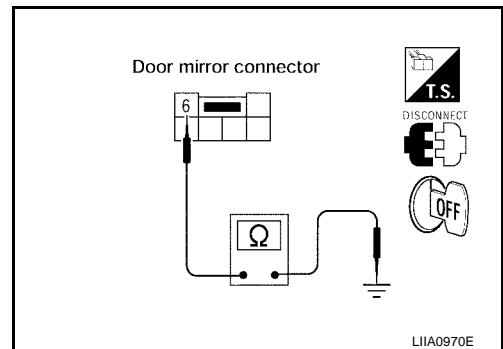

REAR WINDOW DEFOGGER

3. CHECK DOOR MIRROR DEFOGGER

Check continuity between door mirror LH terminals 4 and 6.

4 - 6 : Continuity should exist.

OK or NG

- OK >> Repair or replace harness.
- NG >> Replace door mirror LH. Refer to [GW-90, "Door Mirror Assembly"](#).

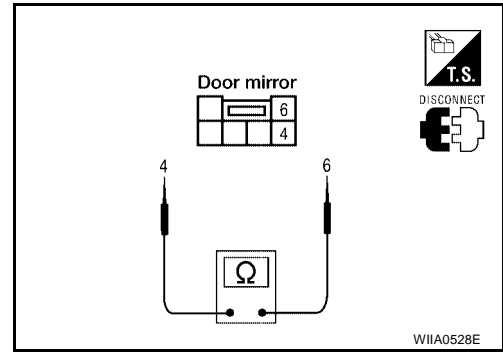

Door Mirror LH (Door Mirror Defogger) Circuit Check (With Automatic Drive Positioner)

EIS00A05

1. CHECK DOOR MIRROR DEFOGGER POWER SUPPLY CIRCUIT

1. Turn ignition switch OFF.
2. Disconnect door mirror LH.
3. Turn ignition switch ON.
4. Check voltage between door mirror LH connector and ground.

Connector	Terminal		Condition	Voltage (V) (Approx.)
	(+)	(-)		
D4	10	Ground	Rear window defogger switch ON	Battery voltage
			Rear window defogger switch OFF	0

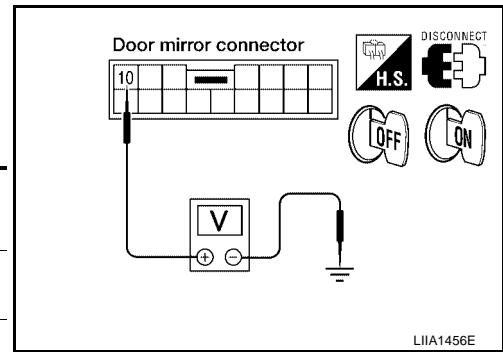

OK or NG

- OK >> GO TO 2.
- NG >> Repair or replace harness.

2. CHECK DOOR MIRROR DEFOGGER GROUND CIRCUIT

1. Turn ignition switch OFF.
2. Check continuity between door mirror LH connector D4 terminal 11 and ground.

11 - Ground : Continuity should exist.

OK or NG

- OK >> GO TO 3.
- NG >> Repair or replace harness.

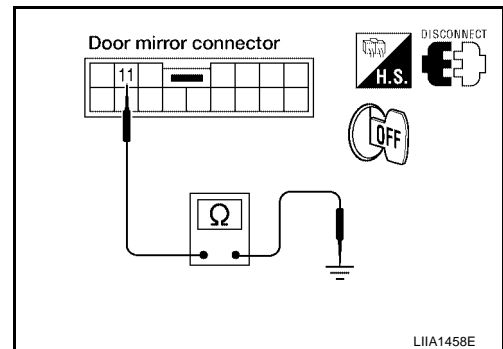

REAR WINDOW DEFOGGER

3. CHECK DOOR MIRROR DEFOGGER

Check continuity between door mirror LH terminals 10 and 11.

10 - 11 : Continuity should exist.

OK or NG

- OK >> Repair or replace harness.
- NG >> Replace door mirror LH. Refer to [GW-90, "Door Mirror Assembly"](#).

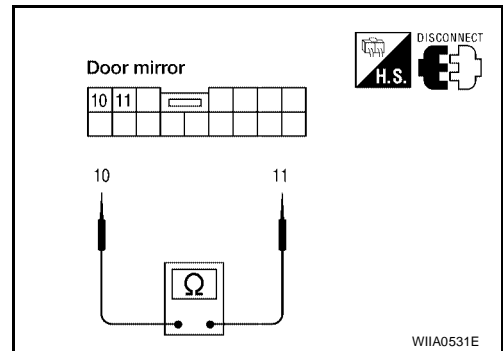

Door Mirror RH (Door Mirror Defogger) Circuit Check (Without Automatic Drive Positioner)

EIS00A06

1. CHECK DOOR MIRROR DEFOGGER POWER SUPPLY CIRCUIT

1. Turn ignition switch OFF.
2. Disconnect door mirror RH.
3. Turn ignition switch ON.
4. Check voltage between door mirror RH connector and ground.

Connector	Terminal		Condition	Voltage (V) (Approx.)
	(+)	(-)		
D107	4	Ground	Rear window defogger switch ON	Battery voltage
			Rear window defogger switch OFF	0

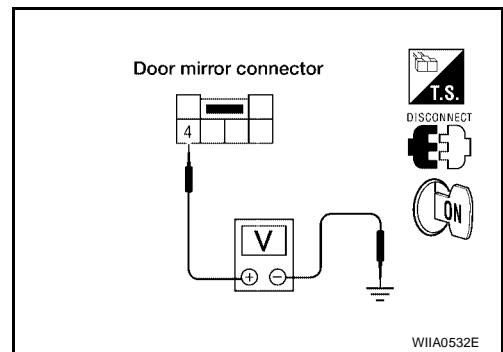

OK or NG

- OK >> GO TO 2.
- NG >> Repair or replace harness.

2. CHECK DOOR MIRROR DEFOGGER GROUND CIRCUIT

1. Turn ignition switch OFF.
2. Check continuity between door mirror RH connector D107 terminal 6 and ground.

6 - Ground : Continuity should exist.

OK or NG

- OK >> GO TO 3.
- NG >> Repair or replace harness.

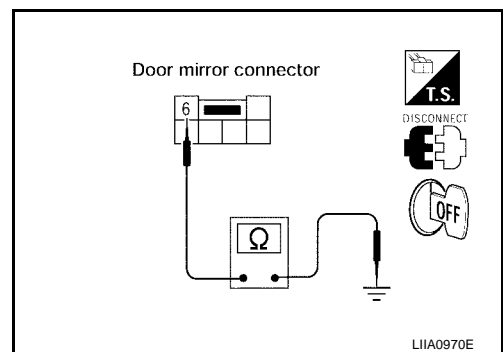

REAR WINDOW DEFOGGER

3. CHECK DOOR MIRROR DEFOGGER

Check continuity between door mirror RH terminals 4 and 6.

4 - 6 : Continuity should exist.

OK or NG

- OK >> Repair or replace harness.
- NG >> Replace door mirror RH. Refer to [GW-90, "Door Mirror Assembly"](#).

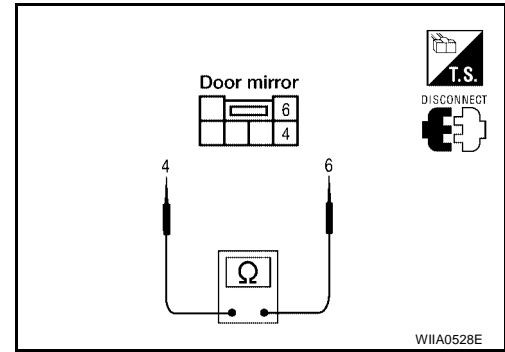

Door Mirror RH (Door Mirror Defogger) Circuit Check (With Automatic Drive Positioner)

EIS00A07

1. CHECK DOOR MIRROR DEFOGGER POWER SUPPLY CIRCUIT

1. Turn ignition switch OFF.
2. Disconnect door mirror RH.
3. Turn ignition switch ON.
4. Check voltage between door mirror RH connector and ground.

Connector	Terminal		Condition	Voltage (V) (Approx.)
	(+)	(-)		
D107	10	Ground	Rear window defogger switch ON	Battery voltage
			Rear window defogger switch OFF	0

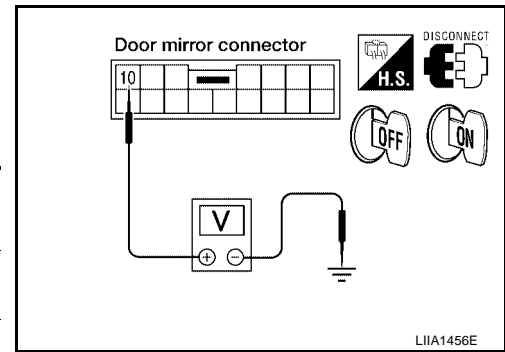

OK or NG

- OK >> GO TO 2.
- NG >> Repair or replace harness.

2. CHECK DOOR MIRROR DEFOGGER GROUND CIRCUIT

1. Turn ignition switch OFF.
2. Check continuity between door mirror RH connector D107 terminal 11 and ground.

11 - Ground : Continuity should exist.

OK or NG

- OK >> GO TO 3.
- NG >> Repair or replace harness.

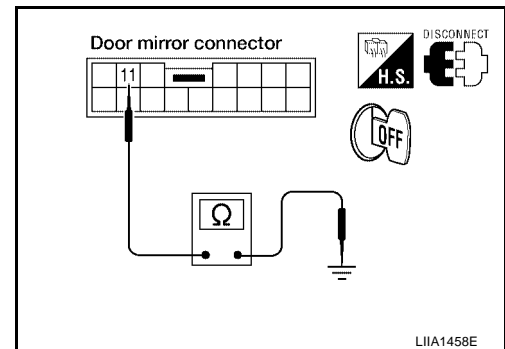

REAR WINDOW DEFOGGER

3. CHECK DOOR MIRROR DEFOGGER

Check continuity between door mirror RH terminals 10 and 11.

10 - 11 : Continuity should exist.

OK or NG

- OK >> Repair or replace harness.
- NG >> Replace door mirror RH. Refer to [GW-90, "Door Mirror Assembly"](#).

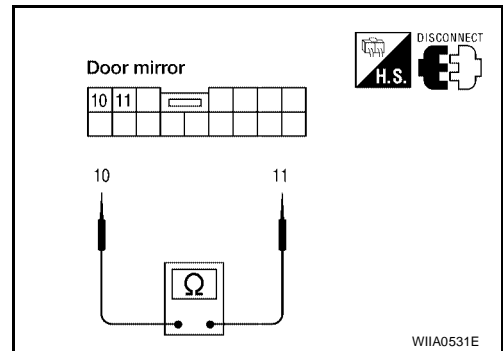

Rear Window Defogger Signal Check

1. CHECK AV COMMUNICATION LINE

AV communication line check is executed. Refer to [AV-144, "CAN Communication Line Check"](#).

Is rear window defogger displayed on the display?

OK or NG

- OK >> GO TO 2.
- NG >> Replace display control unit.

2. CHECK CAN COMMUNICATION LINE

CAN communication line check is executed. Refer to [AV-144, "CAN Communication Line Check"](#).

OK or NG

- OK >> Check the condition of the harness and the connector.
- NG >> In addition, it is necessary to check CAN communication line. Refer to [AV-144, "CAN Communication Line Check"](#).

Filament Check

1. When measuring voltage, wrap tin foil around the top of the negative probe. Then press the foil against the wire with your finger.

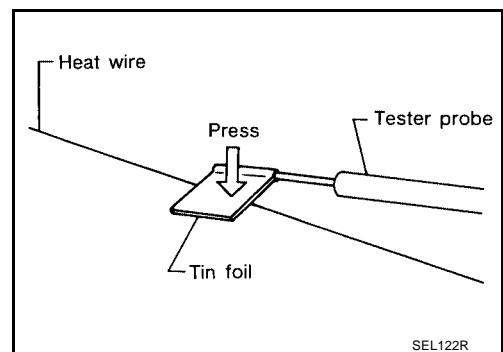

2. Attach probe circuit tester (in Volt range) to middle portion of each filament.

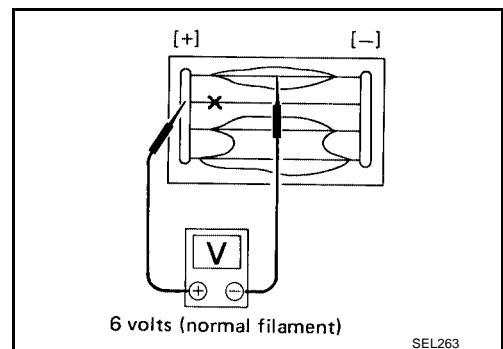

REAR WINDOW DEFOGGER

3. If a filament is burned out, circuit tester registers 0 or battery voltage.
4. To locate burned out point, move probe to left and right along filament. Test needle will swing abruptly when probe passes the point.

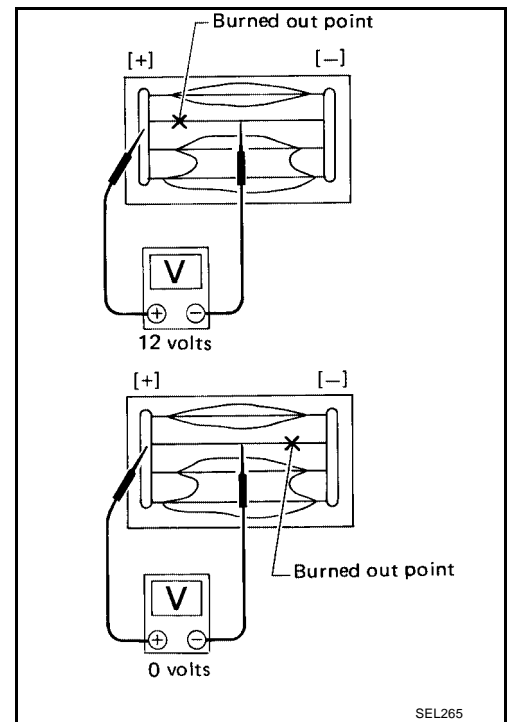

EIS00A0A

Filament Repair REPAIR EQUIPMENT

- Conductive silver composition (DuPont No. 4817 or equivalent)
- Ruler 30 cm (11.8 in) long
- Drawing pen
- Heat gun
- Alcohol
- Cloth

REPAIRING PROCEDURE

1. Wipe broken heat wire and its surrounding area clean with a cloth dampened in alcohol.
2. Apply a small amount of conductive silver composition to tip of drawing pen. Shake silver composition container before use.
3. Place ruler on glass along broken line. Deposit conductive silver composition on break with drawing pen. Slightly overlap existing heat wire on both sides [preferably 5 mm (0.20 in)] of the break.

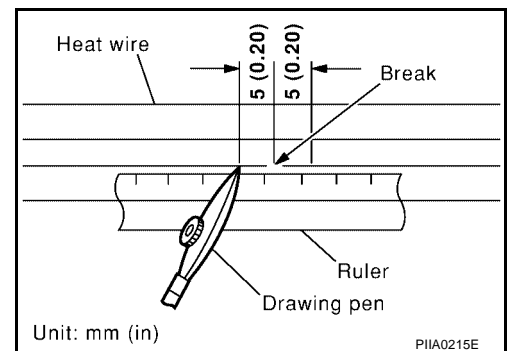

4. After repair has been completed, check repaired wire for continuity. This check should be conducted 10 minutes after silver composition is deposited. Do not touch repaired area while test is being conducted.

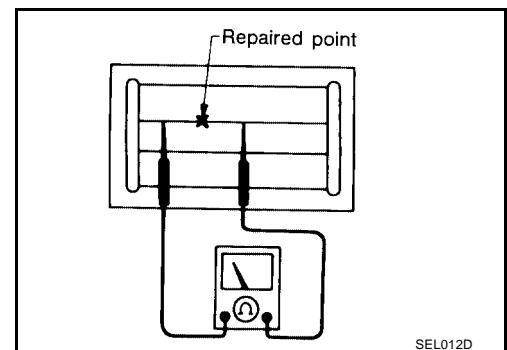

REAR WINDOW DEFOGGER

5. Apply a constant stream of hot air directly to the repaired area for approximately 20 minutes with a heat gun. A minimum distance of 3 cm (1.2 in) should be kept between repaired area and hot air outlet.
If a heat gun is not available, let the repaired area dry for 24 hours.

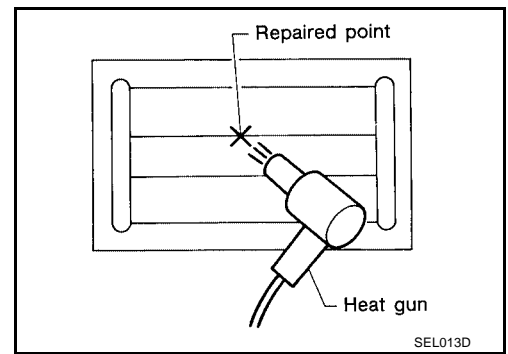

A
B
C
D
E
F
G
H
J
K
L
M

GW

DOOR MIRROR

PF9:96301

DOOR MIRROR

Wiring Diagram — MIRROR — (Without Power Folding Mirrors)

EIS00A0B

GW-MIRROR-01

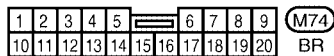
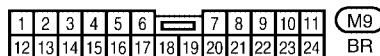
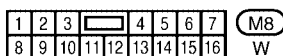
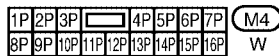
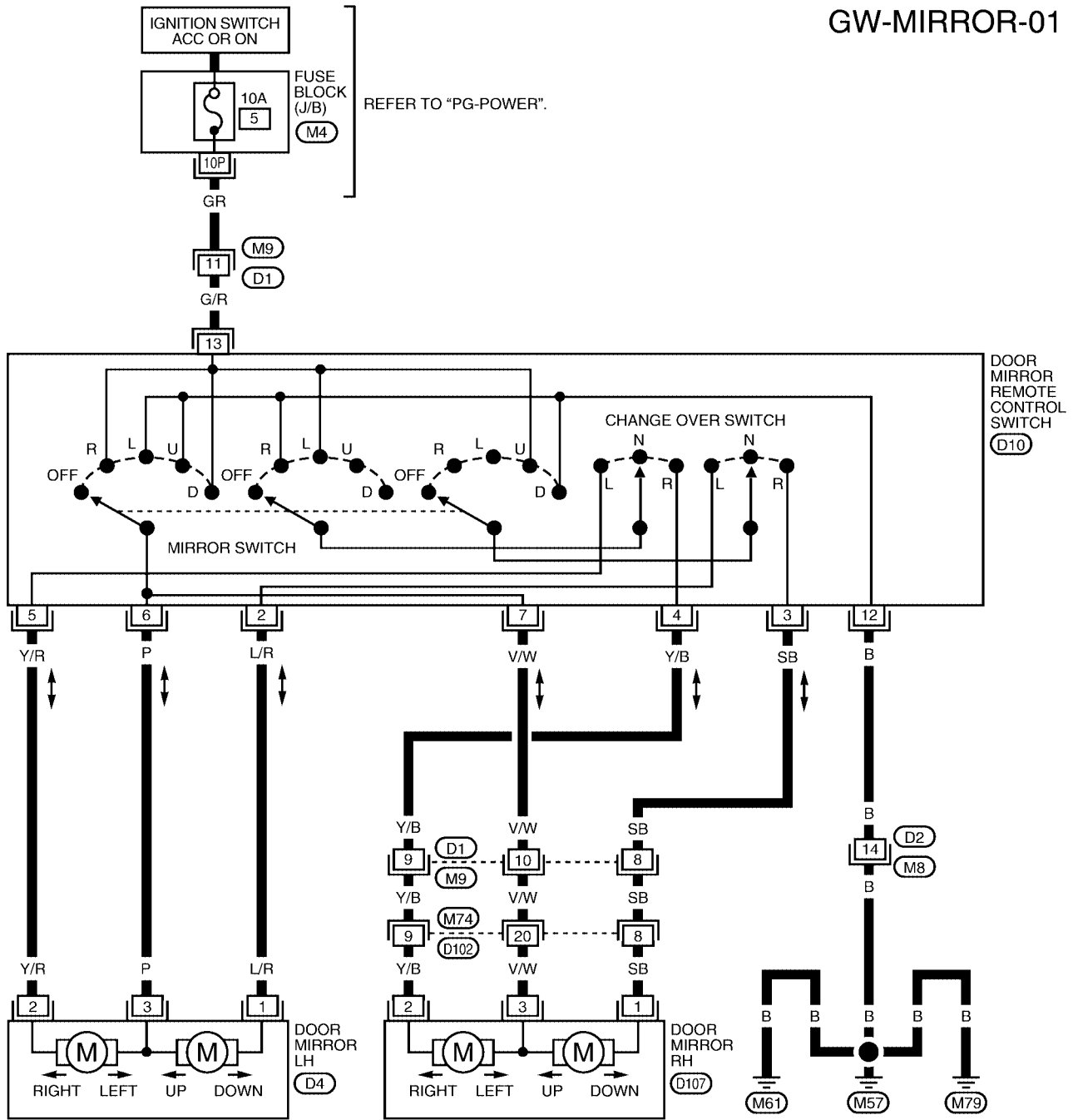

WIWA2011E

DOOR MIRROR

(With Power Folding Mirrors)

GW-MIRROR-02

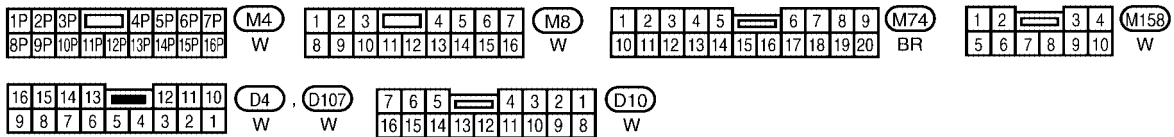
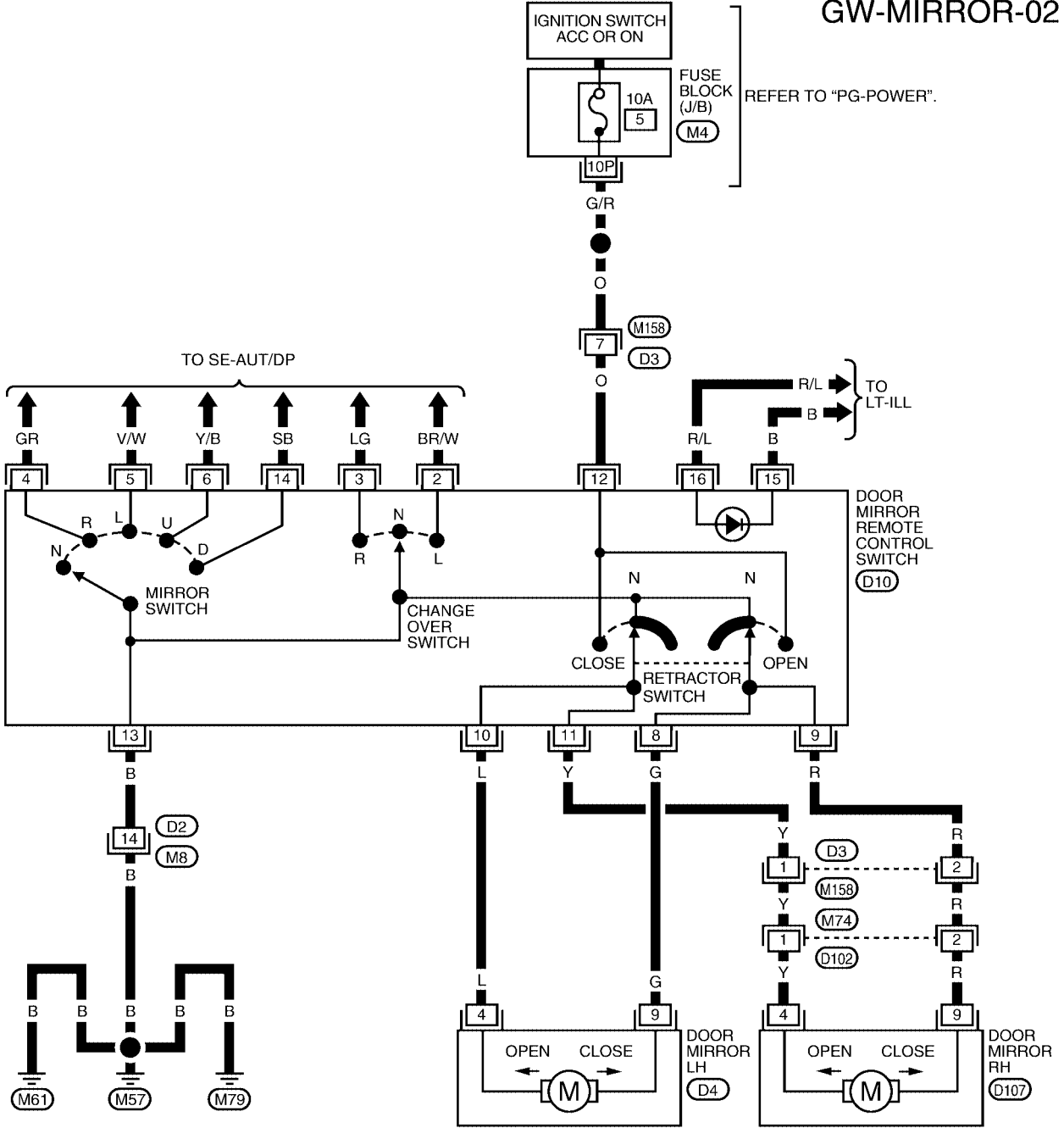

WIWA2028E

DOOR MIRROR

Door Mirror Assembly

EIS00A0C

SEC. 963

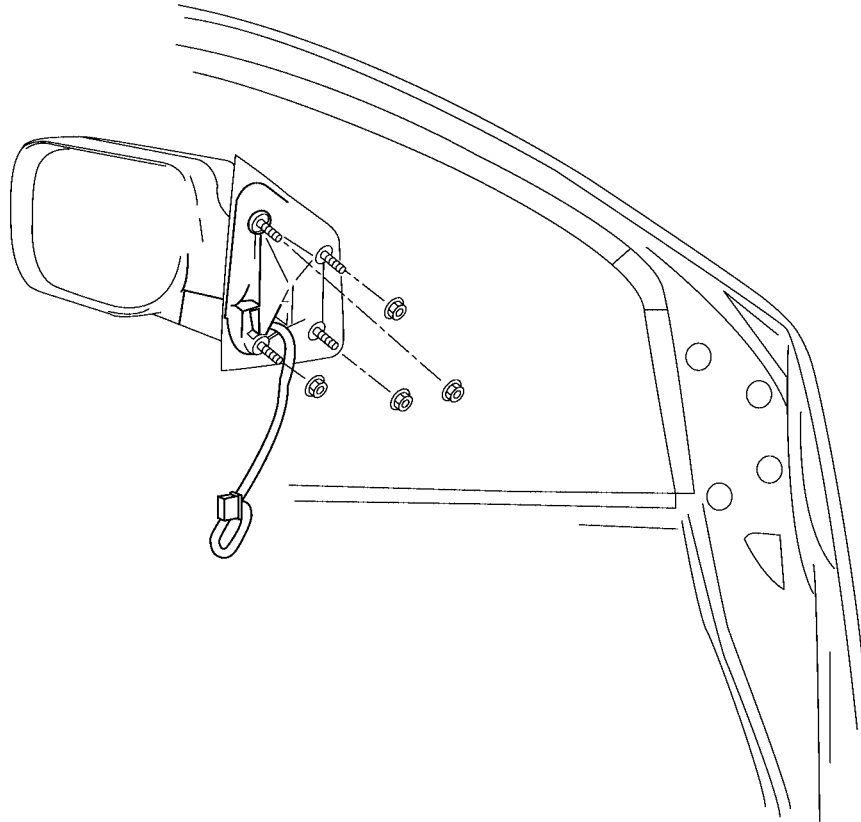

W11A0944E

REMOVAL

NOTE:

Be careful not to damage the mirror bodies.

1. Remove the adhesive front door sash cover.
2. Remove the door mirror harness connector.
3. Remove the door mirror nuts and the door mirror assembly.

INSTALLATION

Installation is in the reverse order of removal.

DOOR MIRROR

EIS00A0D

Door Mirror Glass REMOVAL

1. Set mirror assembly mirror glass upward.
2. Apply protective tape to mirror housing.
3. Insert a screwdriver under tab (1) and gently twist screwdriver to release mirror glass and holder from mirror bracket (2). Remove mirror glass and holder by hand to fully disengage from holder bracket.
4. Disconnect two electrical connectors (3), (4) from mirror glass and holder (heated version only).

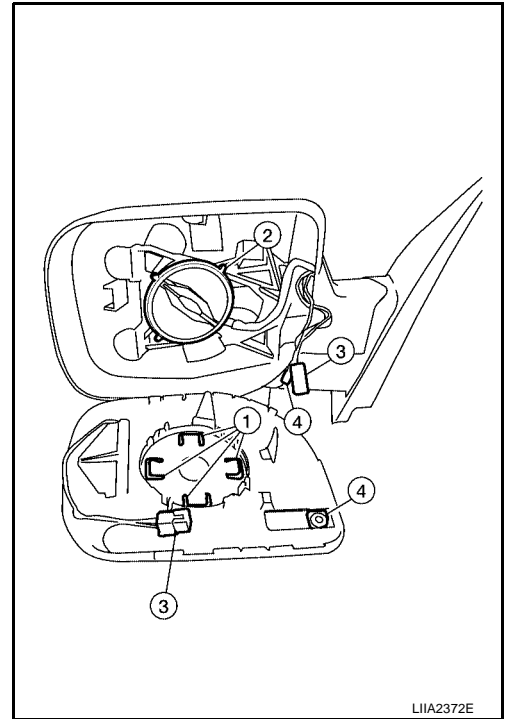

INSTALLATION

1. Set mirror holder bracket and mirror glass and holder in the horizontal position. Ensure that metal dampner blades (1) on mirror glass are aligned with ramps (2) inside plastic mirror case.
2. Connect two electrical connectors (4), (3) to the back of the mirror holder (heated version only).
3. Align mirror glass and holder with mirror holder bracket and push mirror glass and holder onto mirror holder bracket.
4. Rotate mirror to ensure proper installation.

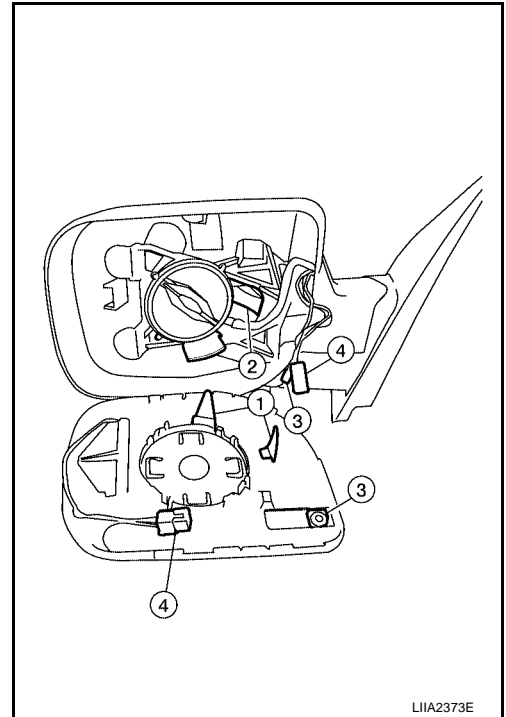

A
B
C
D
E
F
G
H

GW

J
K
L
M

DOOR MIRROR
