

A  
B  
C

# WW

## SECTION

### WIPER, WASHER & HORN

## CONTENTS

<p><b>PRECAUTION</b> ..... 3</p> <p>Precautions for Supplemental Restraint System (SRS) "AIR BAG" and "SEAT BELT PRE-TENSIONER" ..... 3</p> <p><b>FRONT WIPER AND WASHER SYSTEM</b> ..... 4</p> <p>Components Parts and Harness Connector Location ..... 4</p> <p>System Description ..... 4</p> <p>    LOW SPEED WIPER OPERATION ..... 5</p> <p>    HI SPEED WIPER OPERATION ..... 5</p> <p>    INTERMITTENT OPERATION ..... 5</p> <p>    AUTO STOP OPERATION ..... 6</p> <p>    FRONT WASHER OPERATION ..... 6</p> <p>    MIST OPERATION ..... 6</p> <p>    FAIL-SAFE FUNCTION ..... 6</p> <p>    COMBINATION SWITCH READING FUNCTION... 7</p> <p>CAN Communication System Description ..... 7</p> <p>Schematic ..... 8</p> <p>Wiring Diagram — WIPER — ..... 9</p> <p>Terminals and Reference Values for BCM ..... 12</p> <p>Terminals and Reference Values for IPDM E/R .... 12</p> <p>Work Flow ..... 12</p> <p>Preliminary Inspection ..... 12</p> <p>    BCM POWER SUPPLY AND GROUND CIRCUIT CHECK ..... 12</p> <p>CONSULT-II Function (BCM) ..... 12</p> <p>    CONSULT-II START PROCEDURE ..... 12</p> <p>    WORK SUPPORT ..... 12</p> <p>    DATA MONITOR ..... 12</p> <p>    ACTIVE TEST ..... 14</p> <p>CONSULT-II Function (IPDM E/R) ..... 14</p> <p>    CONSULT-II START PROCEDURE ..... 14</p> <p>    DATA MONITOR ..... 14</p> <p>    ACTIVE TEST ..... 15</p> <p>Front Wiper Does Not Operate ..... 15</p> <p>Front Wiper Stop Position Is Incorrect ..... 18</p> <p>Only Front Wiper Low Does Not Operate ..... 19</p> <p>Only Front Wiper High Does Not Operate ..... 21</p> <p>Only Front Wiper Intermittent Does Not Operate ... 22</p> <p>Front Wiper Intermittent Operation Switch Position</p>	<p>Cannot Be Adjusted ..... 23</p> <p>Wipers Do Not Wipe When Front Washer Operates.. 23</p> <p>Front Wipers Operate For 10 Seconds, Stop For 20 Seconds, And After Repeating This Operation Five Times, They Become Inoperative ..... 23</p> <p>Front Wiper Arms ..... 25</p> <p>    REMOVAL AND INSTALLATION ..... 25</p> <p>    FRONT WIPER ARM ADJUSTMENT ..... 25</p> <p>Wiper Motor and Linkage ..... 26</p> <p>    REMOVAL AND INSTALLATION ..... 26</p> <p>    REMOVAL ..... 26</p> <p>    INSTALLATION ..... 26</p> <p>Washer Nozzle Adjustment ..... 26</p> <p>Washer Tube Layout ..... 27</p> <p>Wiper and Washer Switch ..... 27</p> <p>    REMOVAL AND INSTALLATION ..... 27</p> <p>    INSTALLATION ..... 27</p> <p>Washer Fluid Reservoir ..... 27</p> <p>    REMOVAL AND INSTALLATION ..... 27</p> <p>Washer Motor ..... 28</p> <p>    REMOVAL AND INSTALLATION ..... 28</p> <p>    INSTALLATION ..... 28</p> <p><b>REAR WIPER AND WASHER SYSTEM</b> ..... <b>29</b></p> <p>Components Parts and Harness Connector Location ..... 29</p> <p>System Description ..... 29</p> <p>    REAR WIPER OPERATION ..... 30</p> <p>    INTERMITTENT OPERATION ..... 30</p> <p>    AUTO STOP OPERATION ..... 31</p> <p>    REAR WASHER OPERATION ..... 31</p> <p>    BCM WIPER SWITCH READING FUNCTION ... 32</p> <p>Wiring Diagram — WIP/ R — ..... 33</p> <p>Terminals and Reference Values for BCM ..... 35</p> <p>How to Proceed With Trouble Diagnosis ..... 35</p> <p>Preliminary Check ..... 35</p> <p>    INSPECTION FOR POWER SUPPLY AND GROUND CIRCUIT ..... 35</p> <p>CONSULT-II Function (BCM) ..... 35</p> <p>    CONSULT-II START PROCEDURE ..... 35</p> <p>    DATA MONITOR ..... 35</p>
--	---

A  
B  
C  
D  
E  
F  
G  
H  
I  
J  
K  
L  
M

WW

ACTIVE TEST .....	36	Rear Wiper and Washer Switch .....	44
Rear Wiper Does Not Operate .....	36	REMOVAL AND INSTALLATION .....	44
Rear Wiper Stop Position Is Incorrect .....	39	Washer Fluid Reservoir .....	45
Only Rear Wiper Does Not Operate .....	40	REMOVAL AND INSTALLATION .....	45
Only Rear Wiper Intermittent Does Not Operate ...	40	Washer Motor .....	45
Wiper Does Not Wipe When Rear Washer Operates..	41	REMOVAL AND INSTALLATION .....	45
Rear Wiper Arm .....	42	<b>POWER SOCKET .....</b>	<b>46</b>
REMOVAL AND INSTALLATION .....	42	Wiring Diagram — P/SCKT — .....	46
Rear Wiper Motor .....	43	Power Socket LH and Rear Cargo Power Socket...	47
REMOVAL AND INSTALLATION .....	43	REMOVAL AND INSTALLATION .....	47
REMOVAL .....	43	Front Power Socket RH and Console Power Socket..	47
INSTALLATION .....	43	REMOVAL AND INSTALLATION .....	47
Rear Washer Nozzle Adjustment .....	43	<b>HORN .....</b>	<b>48</b>
Rear Washer Tube Layout .....	44	Wiring Diagram — HORN — .....	48
Rear Washer Nozzle .....	44	Horn .....	49
REMOVAL AND INSTALLATION .....	44	REMOVAL AND INSTALLATION .....	49

# PRECAUTION

## PRECAUTION

PF0:00011

### Precautions for Supplemental Restraint System (SRS) “AIR BAG” and “SEAT BELT PRE-TENSIONER”

EKS00J1N

The Supplemental Restraint System such as “AIR BAG” and “SEAT BELT PRE-TENSIONER”, used along with a front seat belt, helps to reduce the risk or severity of injury to the driver and front passenger for certain types of collision. This system includes seat belt switch inputs and dual stage front air bag modules. The SRS system uses the seat belt switches to determine the front air bag deployment, and may only deploy one front air bag, depending on the severity of a collision and whether the front occupants are belted or unbelted. Information necessary to service the system safely is included in the SRS and SB section of this Service Manual.

#### **WARNING:**

- To avoid rendering the SRS inoperative, which could increase the risk of personal injury or death in the event of a collision which would result in air bag inflation, all maintenance must be performed by an authorized NISSAN/INFINITI dealer.
- Improper maintenance, including incorrect removal and installation of the SRS, can lead to personal injury caused by unintentional activation of the system. For removal of Spiral Cable and Air Bag Module, see the SRS section.
- Do not use electrical test equipment on any circuit related to the SRS unless instructed to in this Service Manual. SRS wiring harnesses can be identified by yellow and/or orange harnesses or harness connectors.

A  
B  
C  
D  
E  
F  
G  
H  
I  
J  
L  
M

WW

# FRONT WIPER AND WASHER SYSTEM

## FRONT WIPER AND WASHER SYSTEM

PFP:28810

### Components Parts and Harness Connector Location

EKS00J10

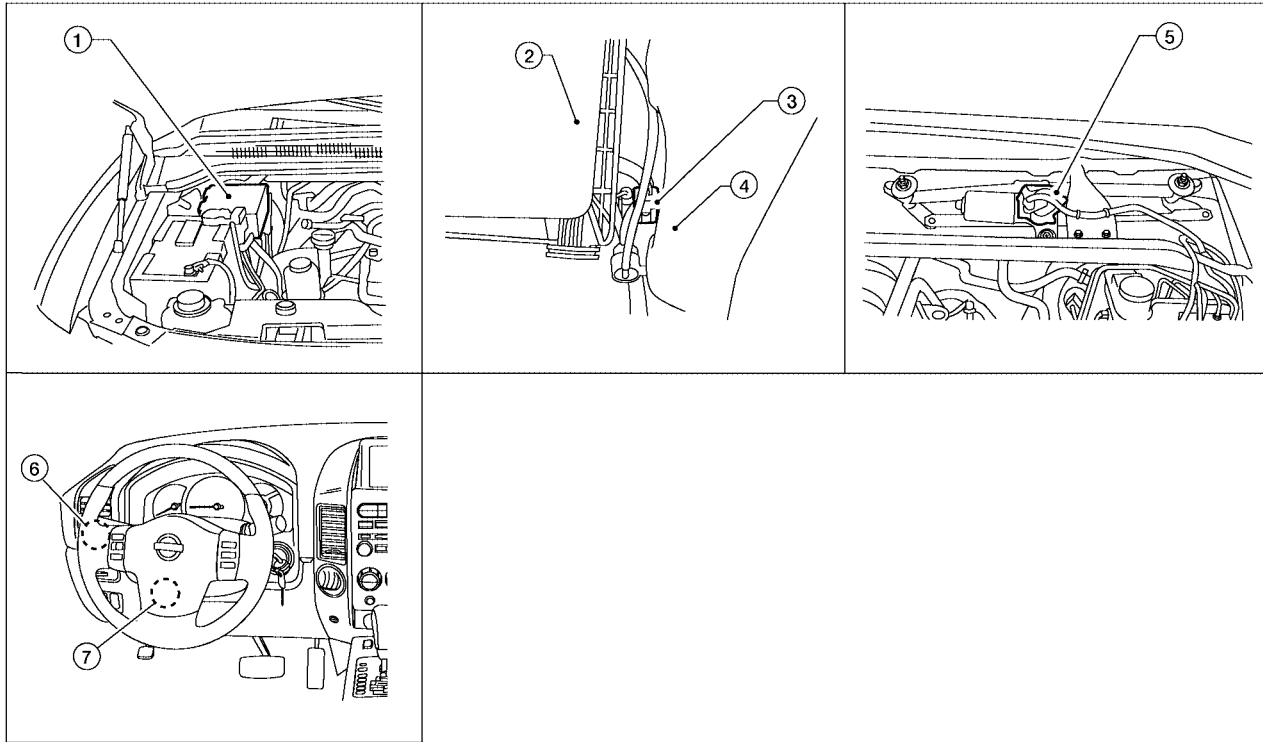

WKIA4827E

- |                              |  |                                     |
|------------------------------|--|-------------------------------------|
| 1. IPDM E/R E121, E122, E124 | 2. Air cleaner case                                      | 3. Front and rear washer motor E105 |
| 4. Washer fluid reservoir    | 5. Front wiper motor E23<br>(view with cowl top removed) | 6. Combination switch M28           |
| 7. BCM M18, M20              |  |                                     |

### System Description

EKS00J1P

- Both front wiper relays are located in the IPDM E/R (intelligent power distribution module engine room).
- The wiper switch (combination switch) is composed of a combination of 5 output terminals and 5 input terminals. Terminal combination status is read by the BCM (body control module) when the wiper switch is turned ON.
- BCM controls front wiper LO, HI, and INT (intermittent) operation.
- IPDM E/R operates the wiper motor according to CAN communication signals from the BCM.

Power is supplied at all times

- to ignition relay, located in the IPDM E/R, and
- through 50A fusible link (letter f , located in the fuse and fusible link box)
- to BCM terminal 70, and
- through 30A fuse (No. 39, located in the IPDM E/R)
- to front wiper relay (located in the IPDM E/R).

With the ignition switch in ON or START position, power is supplied

- to ignition relay, located in the IPDM E/R, and
- through 10A fuse (No. 9, located in the fuse block J/B)
- to combination switch terminal 14, and
- through 10A fuse (No. 59, located in the fuse and relay box)
- to BCM terminal 38.

# FRONT WIPER AND WASHER SYSTEM

Ground is supplied

- to BCM terminal 67 and
- to combination switch terminal 12
- through grounds M57, M61 and M79, and
- to IPDM E/R terminals 38 and 59 and
- to front wiper motor terminal 1
- through grounds E9, E15 and E24.

A  
B  
C

## LOW SPEED WIPER OPERATION

When the ignition switch is in the ON or START position, and the front wiper switch is turned to the low position, the BCM detects a low speed wiper ON request through the combination switch (wiper switch) reading function.

The BCM then sends a front wiper (low) request signal over CAN communication lines

- from BCM terminals 39 and 40
- to IPDM E/R terminals 39 and 40.

E  
F

When IPDM E/R receives front wiper (low) request signal, it supplies ground to energize the front wiper relay. With the front wiper relay energized, power is supplied

- through front wiper relay
- to front wiper high relay
- through IPDM E/R terminal 32
- to front wiper motor terminal 3.

G  
H

With power and ground supplied, the front wiper motor operates at low speed.

## HI SPEED WIPER OPERATION

When the ignition switch is in the ON or START position, and the front wiper switch is turned to the high position, the BCM detects a high speed wiper ON request through the combination switch (wiper switch) reading function.

The BCM then sends a front wiper (high) request signal over CAN communication lines

- from BCM terminals 39 and 40
- to IPDM E/R terminals 39 and 40.

J  
WW

When the IPDM E/R receives a front wiper (high) request signal, it supplies ground to energize the front wiper and the front wiper high relays.

With the front wiper and the front wiper high relays energized, power is supplied

- through front wiper relay
- to front wiper high relay
- through IPDM E/R terminal 35
- to front wiper motor terminal 2.

L  
M

With power and ground supplied, the front wiper motor operates at high speed.

## INTERMITTENT OPERATION

Wiper intermittent operation delay interval is determined from the combination of the intermittent wiper dial position inputs and vehicle speed. During each intermittent operation delay interval, the BCM sends a front wiper request signal to the IPDM E/R to operate the wipers.

When the ignition switch is in the ON or START position, and the front wiper switch is turned to an intermittent position, the BCM detects a front wiper (intermittent) ON request through the combination switch (wiper switch) reading function.

The BCM then sends a front wiper (intermittent) request signal over CAN communication lines

- from BCM terminals 39 and 40
- to IPDM E/R terminals 39 and 40.

When the BCM determines that combination switch status is front wiper intermittent ON, it performs the following operations.

- BCM detects ON/OFF status of intermittent wiper dial position.
- BCM calculates operation interval from wiper dial position and vehicle speed signal received through CAN communications.

# FRONT WIPER AND WASHER SYSTEM

---

- BCM sends front wiper request signal (INT) to IPDM E/R at calculated operation interval.

When the IPDM E/R receives a front wiper request signal (INT), it supplies ground to energize the front wiper relay. It then sends an auto-stop signal to the BCM, and conducts intermittent front wiper motor operation.

## AUTO STOP OPERATION

When the wiper arms are not located at the base of the windshield, and the wiper switch is turned OFF, the wiper motor will continue to operate until the wiper arms reach the windshield base. When the wiper arms reach the base of windshield, front wiper motor terminals 6 and 1 are connected.

Ground is supplied

- to IPDM E/R terminal 43
- through front wiper motor terminal 6
- through front wiper motor terminal 1
- through grounds E9, E15 and E24.

The IPDM E/R sends an auto stop operation signal to the BCM through CAN communication lines.

When the BCM receives an auto stop operation signal, the BCM sends wiper stop signal to the IPDM E/R over CAN communication lines. The IPDM E/R then de-energizes the front wiper relay.

The wiper motor will then stop the wiper arms at the STOP position.

## FRONT WASHER OPERATION

When the ignition switch is in the ON or START position, and the front and rear washer switches are OFF, the front and rear washer motor is supplied power

- through 10A fuse (No. 9, located in the fuse block J/B)
- through combination switch (wiper switch) terminal 14
- through combination switch (wiper switch) terminal 13
- to front and rear washer motor terminal 1, and
- through combination switch (wiper switch) terminal 11
- to front and rear washer motor terminal 2.

When the front wiper switch is in the front washer position, the BCM detects a front washer signal request through the combination switch (wiper switch) reading function.

Combination switch ground is supplied

- to front and rear washer motor terminal 2
- through combination switch (wiper switch) terminal 11
- through combination switch (wiper switch) terminal 12
- through grounds M57, M61 and M79.

With ground supplied, the front and rear washer motor is operated in the front direction.

When the BCM detects that front washer motor has operated for 0.4 seconds or longer, the BCM uses CAN communication and sends a wiper request signal to the IPDM E/R for low speed operation of wipers.

When the BCM detects that the washer switch is OFF, low speed operation cycles approximately 3 times and then stops.

## MIST OPERATION

When the wiper switch is temporarily placed in the mist position, wiper low speed operation cycles once and then stops.

For additional information about wiper operation under this condition, refer to [WW-5, "LOW SPEED WIPER OPERATION"](#).

If the switch is held in the mist position, low speed operation continues.

## FAIL-SAFE FUNCTION

The BCM includes fail-safe function to prevent malfunction of electrical components controlled by CAN communications if a malfunction in CAN communications occurs.

The BCM uses CAN communications to stop output of electrical components it controls.

Until the ignition switch is turned off, the front wiper system remains in same status as just before fail-safe control was initiated. (If wiper was in low speed operation just before fail-safe, it continues low speed operation until ignition switch is turned OFF.)

When fail-safe status is initiated, the BCM remains in standby until normal signals are received.

When normal signals are received, fail-safe status is canceled.

# FRONT WIPER AND WASHER SYSTEM

---

## COMBINATION SWITCH READING FUNCTION

Refer to [BCS-3, "COMBINATION SWITCH READING FUNCTION"](#) .

## CAN Communication System Description

Refer to [LAN-4, "SYSTEM DESCRIPTION"](#) .

A

EKS00J1Q

B

C

D

E

F

G

H

I

J

WW

L

M

# FRONT WIPER AND WASHER SYSTEM

## Schematic

EKS00J1R

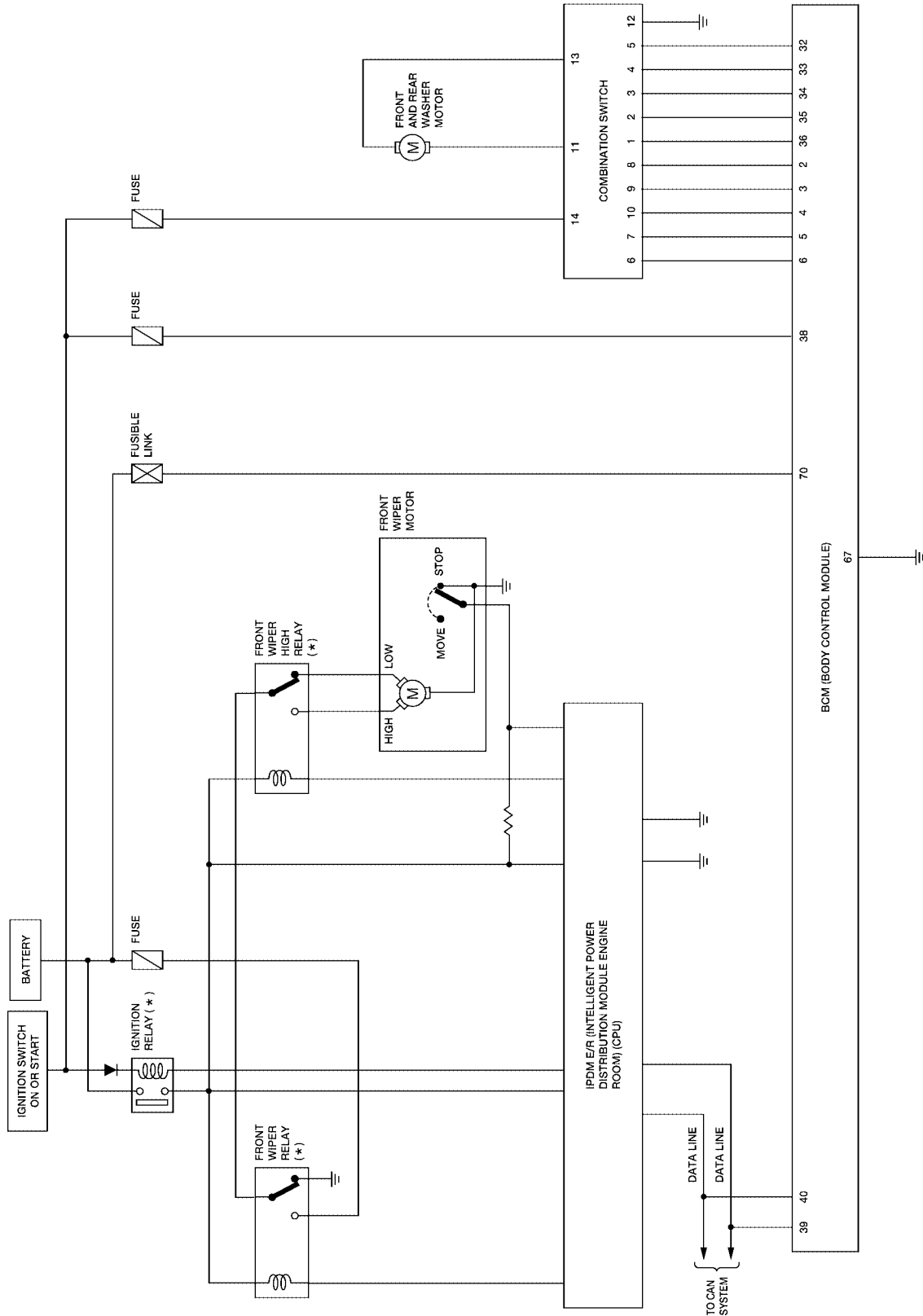

\*: THIS RELAY IS BUILT INTO THE IPDM E/R (INTELLIGENT POWER DISTRIBUTION MODULE ENGINE ROOM).

WKWA3814E



# FRONT WIPER AND WASHER SYSTEM

## Wiring Diagram — WIPER —

EKS00J1S

### WW-WIPER-01

▬ : DATA LINE

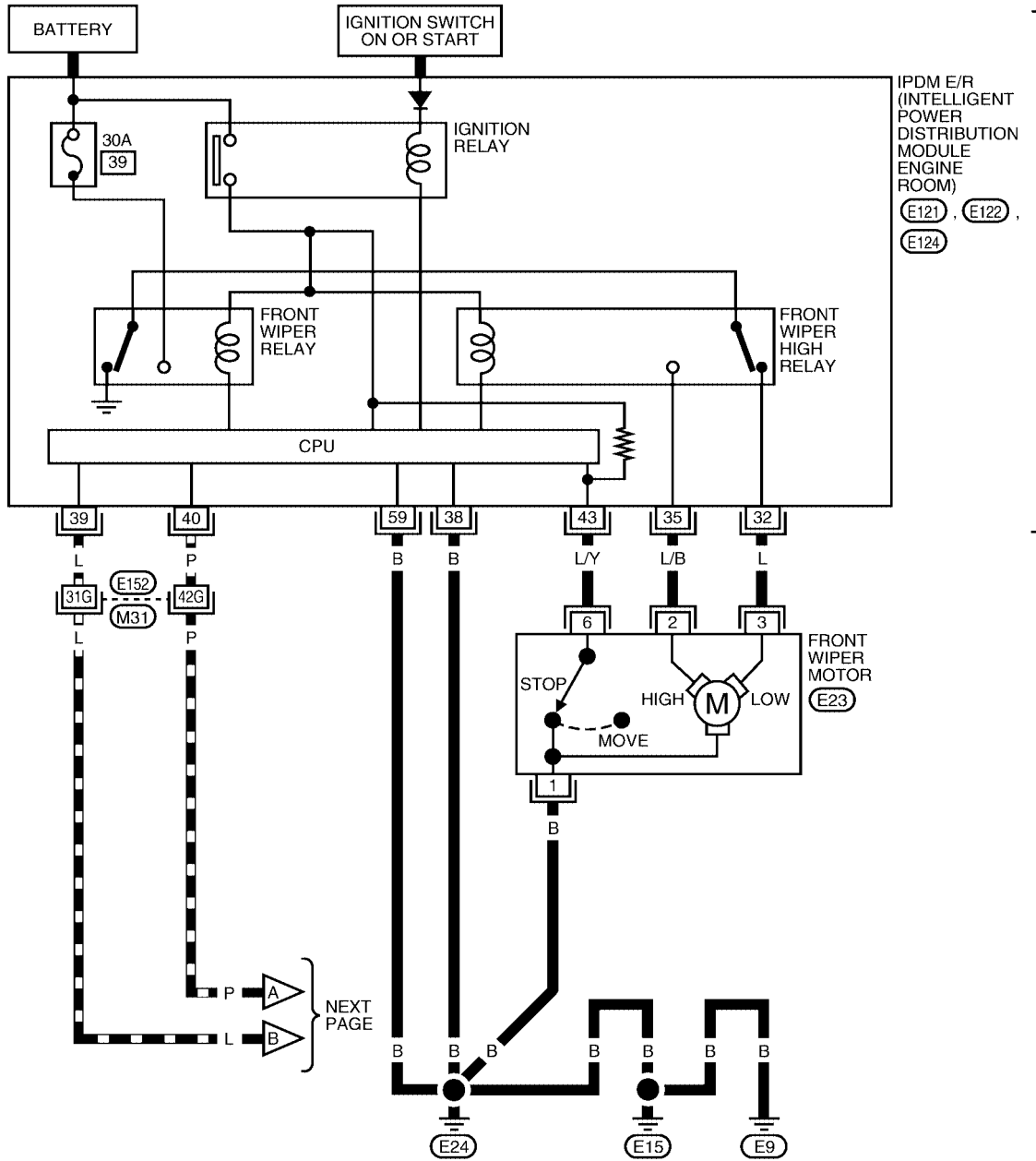

A  
B  
C  
D  
E  
F  
G  
H  
I  
J  
L  
M

WW

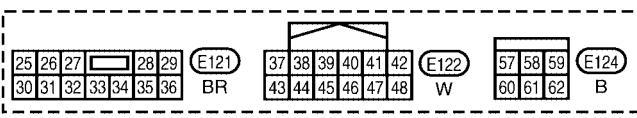
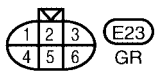

REFER TO THE FOLLOWING.  
**(M31)** - SUPER MULTIPLE JUNCTION (SMJ)

WKWA3521E

# FRONT WIPER AND WASHER SYSTEM

WW-WIPER-02

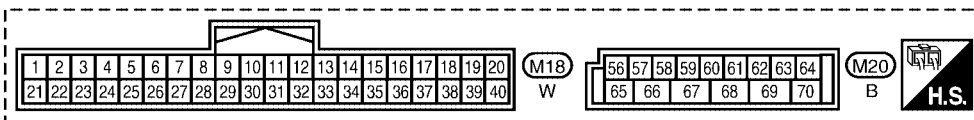
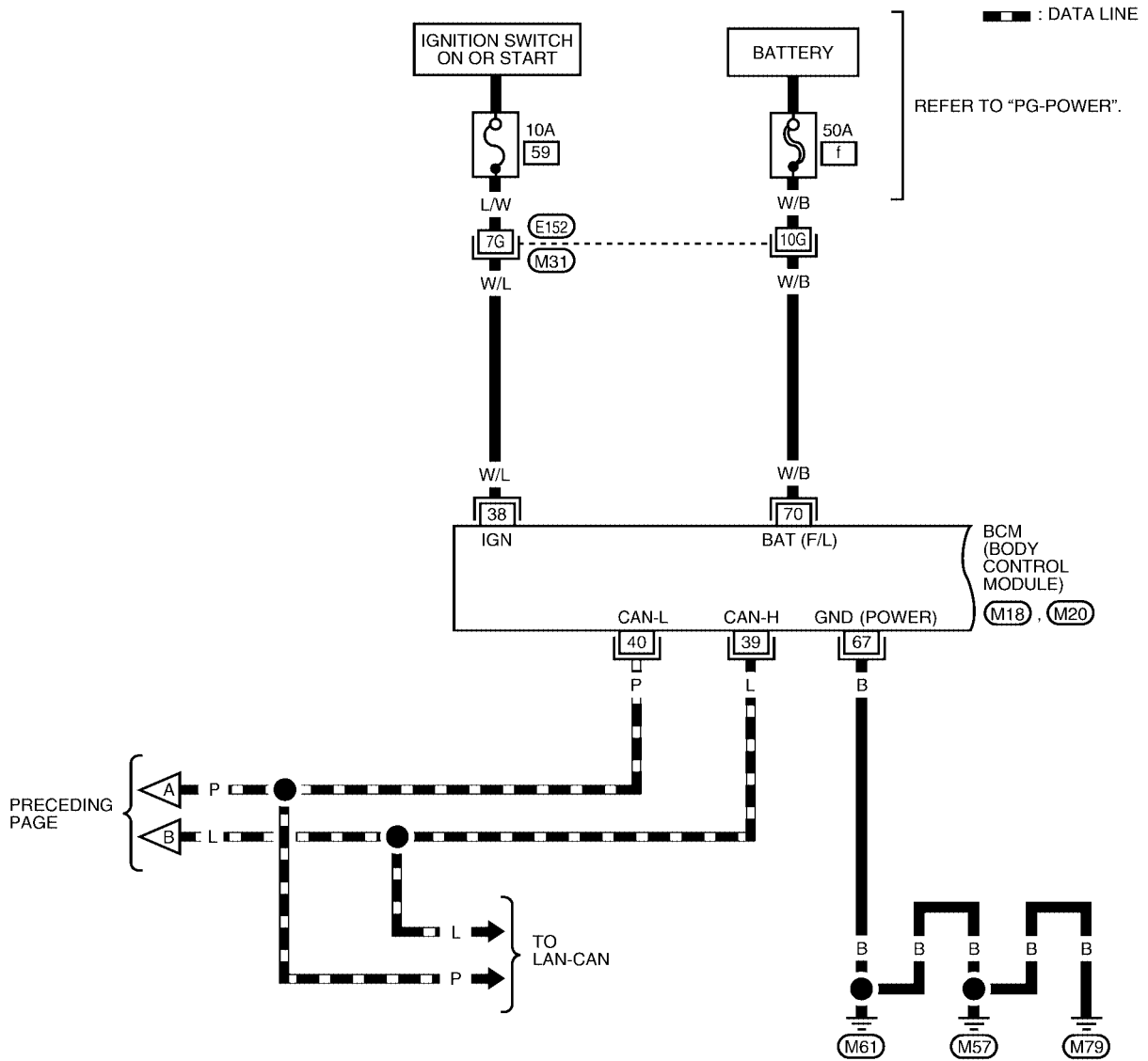

REFER TO THE FOLLOWING.  
 (M31) - SUPER MULTIPLE JUNCTION (SMJ)

WKWA3522E

# FRONT WIPER AND WASHER SYSTEM

WW-WIPER-03

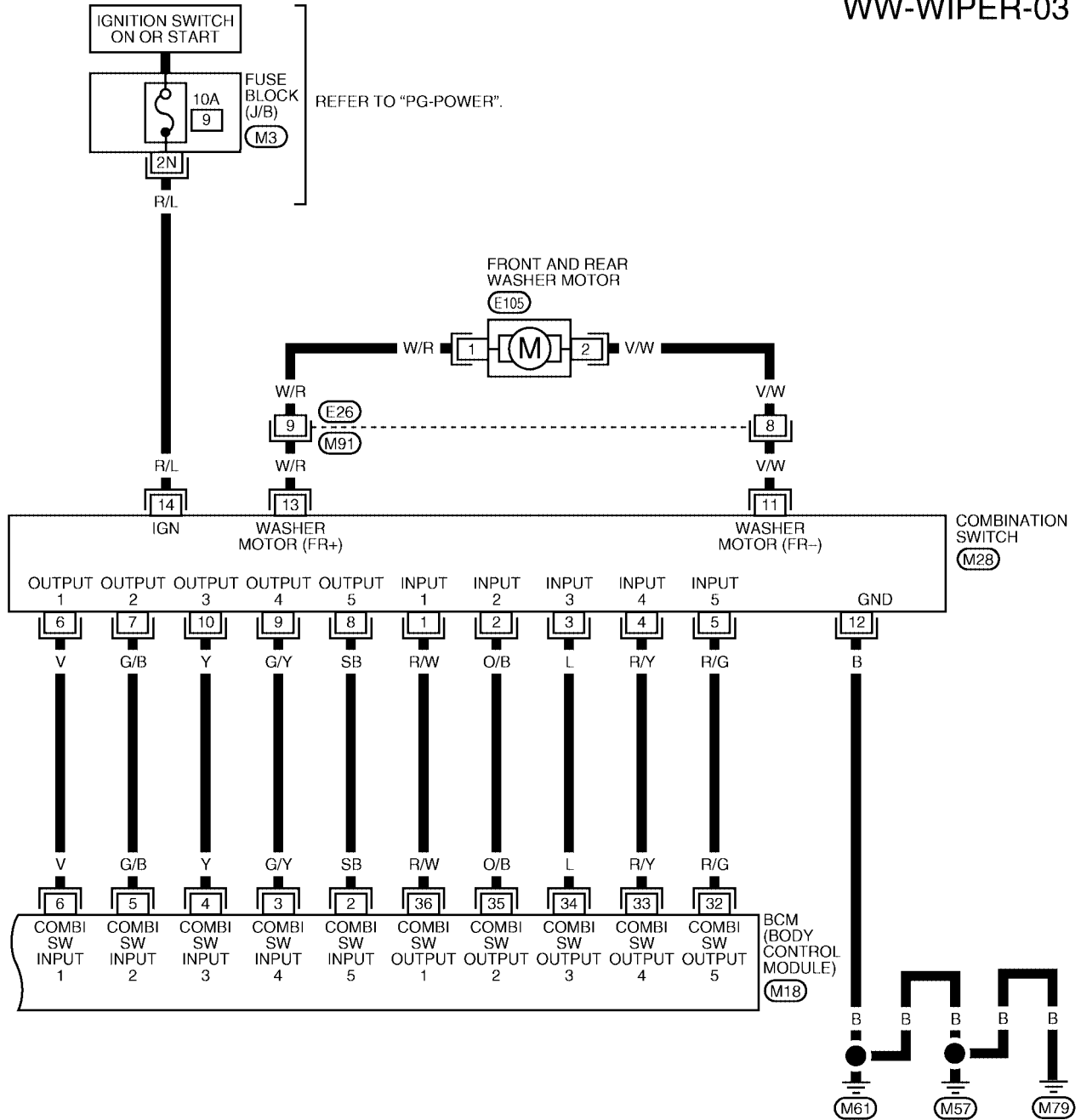

A  
B  
C  
D  
E  
F  
G  
H  
I  
J  
K  
L  
M

WW

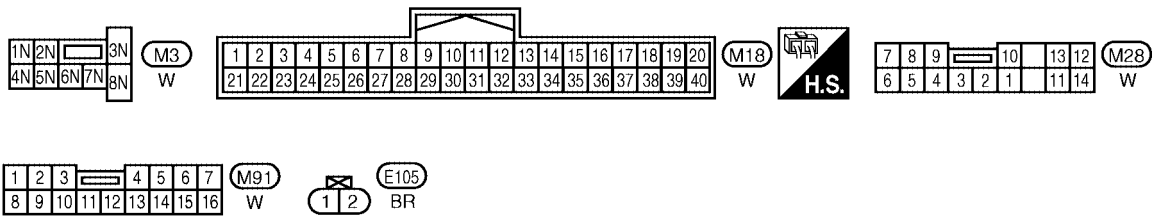

WKWA3523E

# FRONT WIPER AND WASHER SYSTEM

## Terminals and Reference Values for BCM

EKS00J1T

Refer to [BCS-12, "Terminals and Reference Values for BCM"](#) .

## Terminals and Reference Values for IPDM E/R

EKS00J1U

Refer to [AV-30, "Terminals and Reference Value for Audio Unit for Base System"](#) .

## Work Flow

EKS00J1V

1. Confirm the symptom or customer complaint.
2. Understand the system description, refer to [WW-4, "System Description"](#) .
3. Perform preliminary inspection, refer to [WW-12, "Preliminary Inspection"](#) .
4. Check symptom and repair or replace the cause of malfunction.
5. Does wiper function operate normally? If it operates normally, GO TO 6. If not, GO TO 4.
6. Inspection End.

## Preliminary Inspection

EKS00J1W

### BCM POWER SUPPLY AND GROUND CIRCUIT CHECK

Refer to [BCS-17, "BCM Power Supply and Ground Circuit Check"](#) .

## CONSULT-II Function (BCM)

EKS00J1X

CONSULT-II can display each diagnostic item using the diagnostic test modes shown following.

BCM diagnostic test item	Diagnostic mode	Description
Inspection by part	WORK SUPPORT	Supports inspections and adjustments. Commands are transmitted to the BCM for setting the status suitable for required operation, input/output signals are received from the BCM and received data is displayed.
	DATA MONITOR	Displays BCM input/output data in real time.
	ACTIVE TEST	Operation of electrical loads can be checked by sending drive signal to them.
	SELF-DIAG RESULTS	Displays BCM self-diagnosis results.
	CAN DIAG SUPPORT MNTR	The result of transmit/receive diagnosis of CAN communication can be read.
	ECU PART NUMBER	BCM part number can be read.
	CONFIGURATION	Performs BCM configuration read/write functions.

## CONSULT-II START PROCEDURE

Refer to [GI-38, "CONSULT-II Start Procedure"](#) .

## WORK SUPPORT

### Work Support Setting Item

Item	Description	CONSULT-II
WIPER SPEED SETTING	When wiper switch is at INTERMITTENT, front wiper intermittent time can be selected according to vehicle speed. ● ON (Operated)/OFF (Not operated)	ON/OFF

## DATA MONITOR

### Display Item List

Monitor item name "OPERATION OR UNIT"	Contents
IGN ON SW "ON/OFF"	Displays "IGN Position (ON)/OFF, ACC Position (OFF)" status as judged from ignition switch signal.
IGN SW CAN "ON/OFF"	Displays "IGN switch ON (ON)/Other OFF or ACC (OFF)" status as judged from CAN communications.
FR WIPER HI "ON/OFF"	Displays "Front Wiper HI (ON)/Other (OFF)" status as judged from wiper switch signal.

## FRONT WIPER AND WASHER SYSTEM

Monitor item name "OPERATION OR UNIT"	Contents
FR WIPER LOW                      "ON/OFF"	Displays "Front Wiper LOW (ON)/Other (OFF)" status as judged from wiper switch signal.
FR WIPER INT                      "ON/OFF"	Displays "Front Wiper INT (ON)/Other (OFF)" status as judged from wiper switch signal.
FR WASHER SW                      "ON/OFF"	Displays "Front Washer Switch (ON)/Other (OFF)" status as judged from wiper switch signal.
INT VOLUME                      (1 - 7)	Displays intermittent operation dial position setting (1 - 7) as judged from wiper switch signal.
FR WIPER STOP                      "ON/OFF"	Displays "Stopped (ON)/Operating (OFF)" status as judged from the auto stop signal.
VEHICLE SPEED                      "0.0 km/h"	Displays vehicle speed as received from CAN communication.

A  
B  
C  
D  
E  
F  
G  
H  
I  
J  
L  
M

WW

# FRONT WIPER AND WASHER SYSTEM

## ACTIVE TEST

### Display Item List

Test item	Display on CONSULT-II screen	Description
Front wiper HI output	FR WIPER (HI)	Front wiper HI can be operated by any ON-OFF operation.
Front wiper LO output	FR WIPER (LO)	Front wiper LO can be operated by any ON-OFF operation.
Front wiper INT output	FR WIPER (INT)	Front wiper INT can be operated by any ON-OFF operation.

## CONSULT-II Function (IPDM E/R)

EKS00J1Y

CONSULT-II can display each diagnostic item using the diagnostic test modes shown following.

IPDM E/R diagnostic Mode	Description
SELF-DIAG RESULTS	Displays IPDM E/R self-diagnosis results.
DATA MONITOR	Displays IPDM E/R input/output data in real time.
CAN DIAG SUPPORT MNTR	The result of transmit/receive diagnosis of CAN communication can be read.
ACTIVE TEST	Operation of electrical loads can be checked by sending drive signal to them.

## CONSULT-II START PROCEDURE

Refer to [GI-38, "CONSULT-II Start Procedure"](#) .

## DATA MONITOR

### All Items, Main Items, Select Item Menu

Item name	CONSULT-II screen display	Display or unit	Monitor item selection			Description
			ALL SIGNALS	MAIN SIGNALS	SELECTION FROM MENU	
Front wiper request	FR WIP REQ	STOP/1LO/LO/HI	x	x	x	Signal status input from BCM.
Wiper auto stop	WIP AUTO STOP	ACT P/STOP P	x	x	x	Output status of IPDM E/R.
Wiper protection	WIP PROT	OFF/LS/HS/BLOCK	x	x	x	Control status of IPDM E/R.

### NOTE:

Perform monitoring of IPDM E/R data with the ignition switch ON. When the ignition switch is at ACC, the display may not be correct.

# FRONT WIPER AND WASHER SYSTEM

## ACTIVE TEST

### Operation Procedure

1. Touch "WIPER" on the "SELECT TEST ITEM" screen.
2. Touch "ACTIVE TEST" on the "SELECT DIAG MODE" screen.
3. Touch item(s) to be tested and check operation of the selected item(s).
4. During the operation check, touching "BACK" deactivates the operation.

### Display Item List

Test item	CONSULT-II screen display	Description
Front wiper (HI, LO) output	FRONT WIPER	With a certain operation (OFF, HI, LO) front wiper relays can be operated.

### Front Wiper Does Not Operate

EKS00J1Z

#### CAUTION:

During IPDM E/R fail-safe control, front wipers may not operate. Refer to [PG-18, "CAN COMMUNICATION LINE CONTROL"](#) to make sure that it is not in fail-safe status.

### 1. CHECK IPDM E/R TO FRONT WIPERS

#### ☑ With CONSULT-II

1. Select "IPDM E/R" with CONSULT-II, and select "ACTIVE TEST" on "SELECT DIAG MODE" screen.
2. Select "FRONT WIPER" on "SELECT TEST ITEM" screen.

#### ☒ Without CONSULT-II

1. Turn on front wipers using auto active test. Refer to [PG-22, "Auto Active Test"](#).
2. Confirm front wiper operation.

#### OK or NG

- OK >> GO TO 4.  
 NG >> GO TO 2.

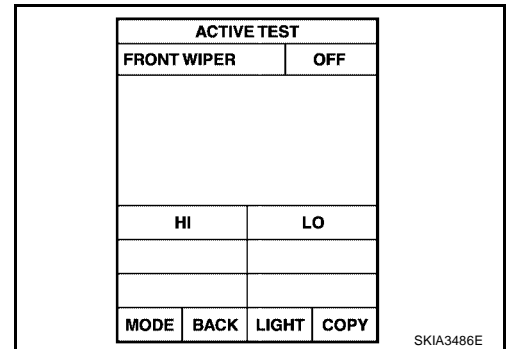

A  
B  
C  
D  
E  
F  
G  
H  
I  
J  
L  
M

WW

# FRONT WIPER AND WASHER SYSTEM

## 2. IPDM E/R TO FRONT WIPERS CIRCUIT INSPECTION

1. Turn ignition switch OFF.
2. Disconnect IPDM E/R connectors and front wiper motor connector.
3. Check continuity between IPDM E/R harness connector terminals and front wiper motor harness connector terminals.

IPDM E/R		Front wiper motor		Continuity
Connector	Terminal	Connector	Terminal	
E121	32	E23	3	Yes
	35		2	
E122	43		6	

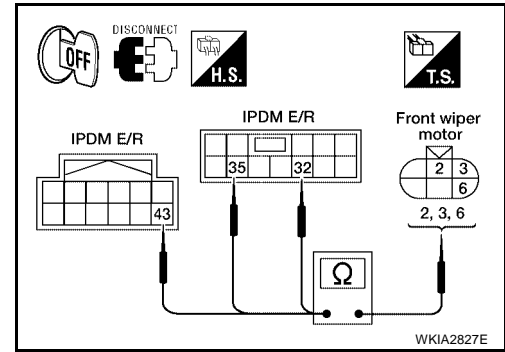

4. Check continuity between IPDM E/R harness connector terminals and ground.

IPDM E/R		Continuity	
Connector	Terminal		
E121	32	Ground	No
	35		
E122	43		

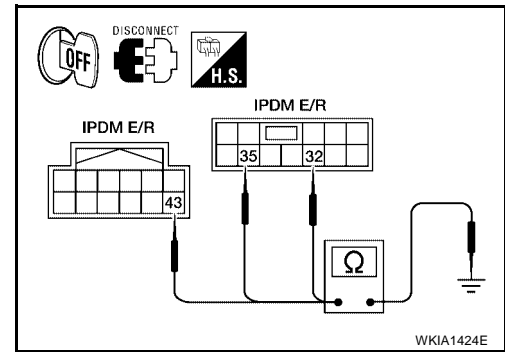

5. Check continuity between IPDM E/R harness connector terminal and ground.

IPDM E/R		Continuity	
Connector	Terminal		
E122	38	Ground	Yes
E124	59		

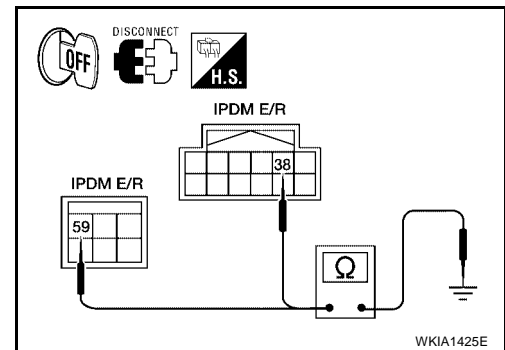

6. Check continuity between front wiper motor harness connector terminal 1 and ground.

Front wiper motor		Continuity	
Connector	Terminal		
E23	1	Ground	Yes

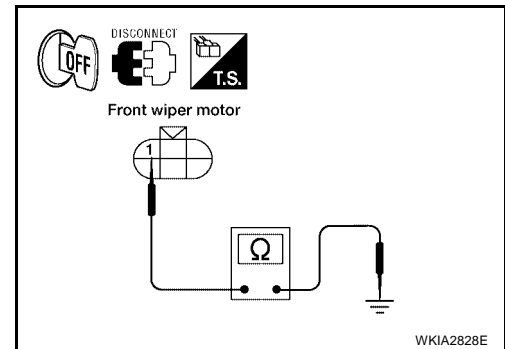

### OK or NG

- OK >> Connect connectors. GO TO 3.
- NG >> Repair harness or connector.



# FRONT WIPER AND WASHER SYSTEM

## 3. IPDM E/R INSPECTION

Ⓜ With CONSULT-II

1. Turn ignition switch ON.
2. Select "HI" on "ACTIVE TEST" screen.
3. When front wiper relay and front wiper high relay are operating, check voltage between IPDM E/R terminals and ground.

ⓧ Without CONSULT-II

1. Turn on front wipers using the auto active test. Refer to [PG-22, "Auto Active Test"](#).
2. When front wiper relay, and front wiper high relay are operating, check voltage between IPDM E/R terminals and ground.

IPDM E/R (+)		(-)	Condition	Voltage (Approx.)
Connector	Terminal			
E121	32	Ground	Stopped	0V
			LO operation	Battery voltage
	35		Stopped	0V
			HI operation	Battery voltage

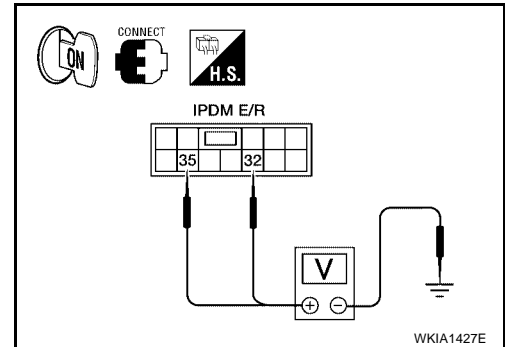

OK or NG

- OK >> Replace the front wiper motor. Refer to [WW-26, "REMOVAL AND INSTALLATION"](#).
- NG >> Replace IPDM E/R. Refer to [PG-30, "Removal and Installation of IPDM E/R"](#).

## 4. COMBINATION SWITCH TO BCM INSPECTION

Select "BCM" on CONSULT-II. With "WIPER" data monitor, check that "FR WIPER INT", "FR WIPER LOW" and "FR WIPER HI" turn ON-OFF according to operation of wiper switch.

OK or NG

- OK >> GO TO 5.
- NG >> Check wiper switch. Refer to [BCS-3, "COMBINATION SWITCH READING FUNCTION"](#).

DATA MONITOR	
MONITOR	
IGN ON SW	OFF
IGN SW CAN	ON
FR WIPER HI	OFF
FR WIPER LOW	OFF
FR WIPER INT	OFF
FR WASHER SW	OFF
INT VOLUME	7
FR WIPER STOP	ON
VEHICLE SPEED	0.0 km/h
PAGE DOWN	
RECORD	
MODE	BACK LIGHT COPY

## 5. BCM INSPECTION

Select "BCM" on CONSULT-II. Carry out self-diagnosis of BCM.

Displayed self-diagnosis results

- NO DTC>> Replace the BCM. Refer to [BCS-26, "Removal and Installation"](#).
- CAN COMM CIRCUIT>> Check CAN communication line of BCM. GO TO [BCS-19, "CAN Communication Inspection Using CONSULT-II \(Self-Diagnosis\)"](#).

SELF-DIAG RESULTS			
DTC RESULTS		TIME	
CAN COMM CIRCUIT [U1000]		PAST	
ERASE		PRINT	
MODE	BACK	LIGHT	COPY

# FRONT WIPER AND WASHER SYSTEM

EKS00J20

## Front Wiper Stop Position Is Incorrect

### 1. CHECK IPDM E/R TO FRONT WIPER MOTOR

④ With CONSULT-II

Select "IPDM E/R" with CONSULT-II. With wiper "DATA MONITOR", confirm that "WIP AUTO STOP" changes from "ACT P" to "STOP P" according to wiper operation.

⊗ Without CONSULT-II

GO TO 2.

OK or NG

OK >> Replace IPDM E/R. Refer to [PG-30, "Removal and Installation of IPDM E/R"](#).

NG >> GO TO 2.

DATA MONITOR	
MOTOR FAN REQ	1
AC COMP REQ	OFF
TAIL&CLR REQ	OFF
HL LO REQ	OFF
HL HI REQ	OFF
FR FOG REQ	OFF
FR WIP REQ	STOP
WIP AUTO STOP	STOP P
WIP PROT	OFF
Page DOWN	
RECORD	
MODE	BACK
LIGHT	COPY

SKIA5301E

### 2. IPDM E/R TO FRONT WIPER MOTOR CIRCUIT INSPECTION

- Turn ignition switch OFF.
- Disconnect IPDM E/R connector and front wiper motor connector.
- Check continuity between IPDM E/R harness connector and front wiper motor harness connector.

IPDM E/R		Front wiper motor		Continuity
Connector	Terminal	Connector	Terminal	
E122	43	E23	6	Yes

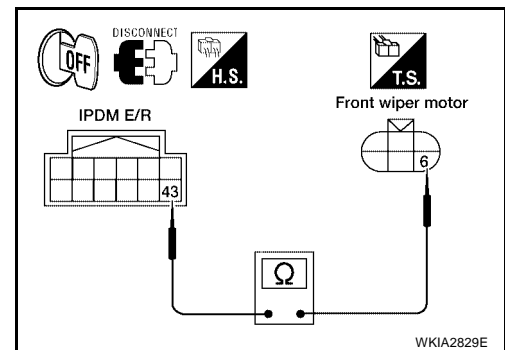

- Check continuity between IPDM E/R harness connector terminal and ground.

IPDM E/R		Continuity
Connector	Terminal	
E122	43	No

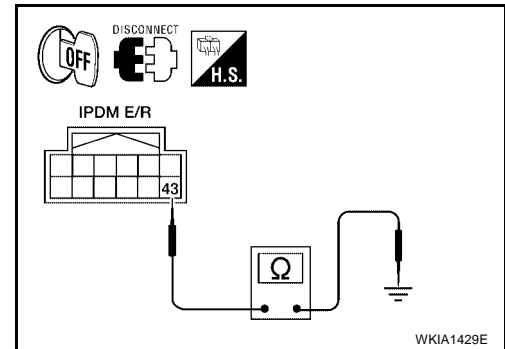

- Check continuity between front wiper motor harness connector terminal 1 and ground.

Front wiper motor		Continuity
Connector	Terminal	
E23	1	Yes

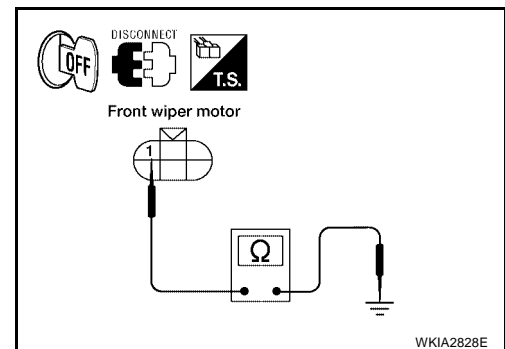

OK or NG

OK >> GO TO 3.

NG >> ● Check for short circuit or open circuit in harness between IPDM E/R and front wiper motor.

- Check for open circuit in harness between front wiper motor and ground.

# FRONT WIPER AND WASHER SYSTEM

## 3. IPDM E/R INSPECTION

Ⓜ With CONSULT-II

1. Connect IPDM E/R connector and front wiper motor connector.
2. Turn ignition switch ON.
3. Select "LO" on "ACTIVE TEST" screen.
4. When front wipers are operating and when stopped, measure voltage between IPDM E/R terminal 43 and ground.

ⓧ Without CONSULT-II

1. Connect IPDM E/R connector and front wiper motor connector.
2. Turn on front wipers using the auto active test. Refer to [PG-22, "Auto Active Test"](#).
3. When front wipers are operating and when stopped, measure voltage between IPDM E/R terminal 43 and ground.

IPDM E/R		(-)	Condition	Voltage (Approx.)
(+) Connector Terminal				
E122	43	Ground	Wiper operating	Battery voltage
			Wiper stopped	0V

OK or NG

- OK >> Replace IPDM E/R. Refer to [PG-30, "Removal and Installation of IPDM E/R"](#).  
 NG >> Replace front wiper motor. Refer to [WW-26, "REMOVAL AND INSTALLATION"](#).

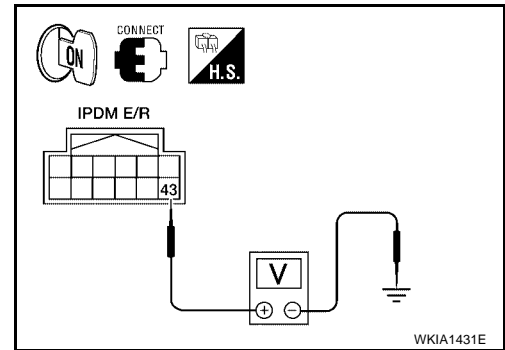

### Only Front Wiper Low Does Not Operate

EKS00J21

#### 1. CHECK IPDM E/R TO FRONT WIPERS

Ⓜ With CONSULT-II

1. Select "IPDM E/R" with CONSULT-II, and select "ACTIVE TEST" on "SELECT DIAG MODE" screen.
2. Select "FRONT WIPER" on "SELECT TEST ITEM" screen.
3. Select "LO" on "ACTIVE TEST" screen.
4. Confirm front wiper low operation.

ⓧ Without CONSULT-II

1. Turn on front wipers using auto active test. Refer to [PG-22, "Auto Active Test"](#).
2. Confirm front wiper low operation.

OK or NG

- OK >> GO TO 4.  
 NG >> GO TO 2.

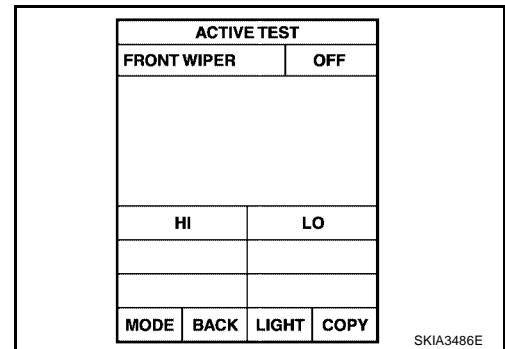

# FRONT WIPER AND WASHER SYSTEM

## 2. IPDM E/R TO FRONT WIPERS CIRCUIT INSPECTION

1. Turn ignition switch OFF.
2. Disconnect IPDM E/R connector and front wiper motor connector.
3. Check continuity between IPDM E/R harness connector terminal and front wiper motor harness connector terminal.

IPDM E/R		Front wiper motor		Continuity
Connector	Terminal	Connector	Terminal	
E121	32	E23	3	Yes

OK or NG

OK >> GO TO 3.

NG >> Check for short circuit or open circuit in harness between IPDM E/R and front wiper motor.

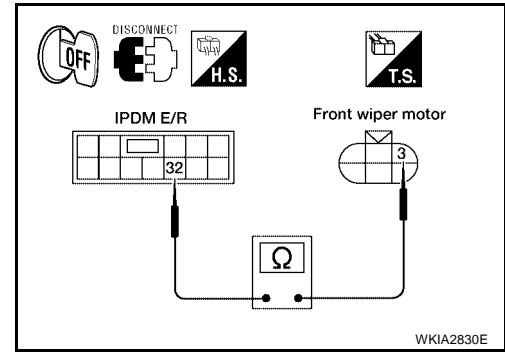

## 3. IPDM E/R INSPECTION

Ⓟ With CONSULT-II

1. Connect IPDM E/R connector and front wiper motor connector.
2. Turn ignition switch ON.
3. Select "LO" on "ACTIVE TEST" screen.
4. When front wiper relay is operating, check voltage between IPDM E/R terminals.

ⓧ Without CONSULT-II

1. Connect IPDM E/R connector and front wiper motor connector.
2. Turn on front wipers using the auto active test. Refer to [PG-22, "Auto Active Test"](#).
3. When front wiper relay is operating, check voltage between IPDM E/R terminals.

IPDM E/R				Voltage (Approx.)
(-)		(+)		
Connector	Terminal	Connector	Terminal	
E122	38	E121	32	Battery voltage
E124	59			

OK or NG

OK >> Replace the wiper motor. Refer to [WW-26, "REMOVAL AND INSTALLATION"](#).

NG >> Replace IPDM E/R. Refer to [PG-30, "Removal and Installation of IPDM E/R"](#).

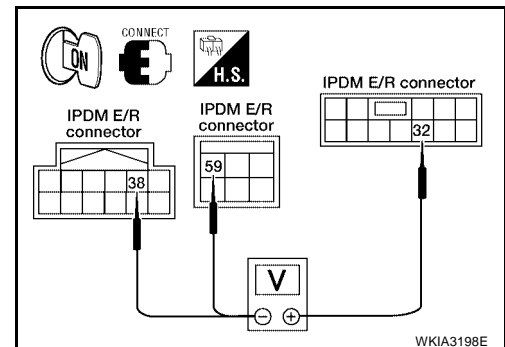

## 4. COMBINATION SWITCH TO BCM INSPECTION

Select "BCM" on CONSULT-II. With "WIPER" data monitor, check that "FR WIPER HI" turns ON-OFF according to operation of wiper switch.

OK or NG

OK >> Replace BCM. Refer to [BCS-26, "Removal and Installation"](#).

NG >> Replace wiper switch. Refer to [WW-27, "REMOVAL AND INSTALLATION"](#).

DATA MONITOR	
MONITOR	
IGN ON SW	OFF
IGN SW CAN	ON
FR WIPER HI	OFF
FR WIPER LOW	OFF
FR WIPER INT	OFF
FR WASHER SW	OFF
INT VOLUME	7
FR WIPER STOP	ON
VEHICLE SPEED	0.0 km/h
PAGE DOWN	
RECORD	
MODE	BACK
LIGHT	COPY

# FRONT WIPER AND WASHER SYSTEM

EKS00J22

## Only Front Wiper High Does Not Operate

### 1. CHECK IPDM E/R TO FRONT WIPERS

☑ With CONSULT-II

1. Select "IPDM E/R" with CONSULT-II, and select "ACTIVE TEST" on "SELECT DIAG MODE" screen.
2. Select "FRONT WIPER" on "SELECT TEST ITEM" screen.
3. Select "HI" on "ACTIVE TEST" screen.
4. Confirm front wiper high operation.

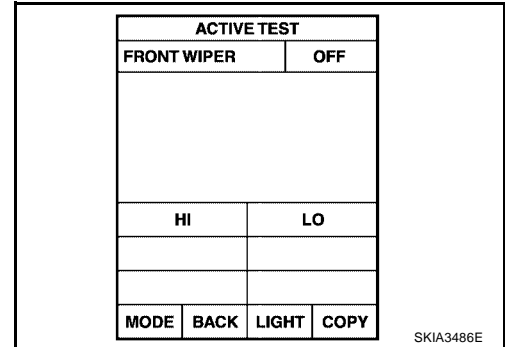

☒ Without CONSULT-II

1. Turn on front wipers using auto active test. Refer to [PG-22](#), "Auto Active Test".
2. Confirm front wiper operation.

OK or NG

- OK >> GO TO 4.  
NG >> GO TO 2.

### 2. IPDM E/R TO FRONT WIPERS CIRCUIT INSPECTION

1. Turn ignition switch OFF.
2. Disconnect IPDM E/R connector and front wiper motor connector.
3. Check continuity between IPDM E/R harness connector terminal and front wiper motor harness connector terminal.

IPDM E/R		Front wiper motor		Continuity
Connector	Terminal	Connector	Terminal	
E121	35	E23	2	Yes

OK or NG

- OK >> GO TO 3.  
NG >> Check for short circuit or open circuit in harness between IPDM E/R and front wiper motor.

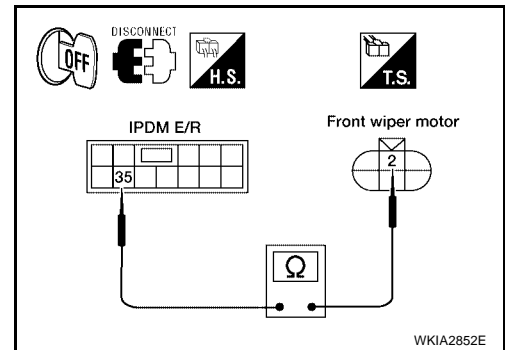

A  
B  
C  
D  
E  
F  
G  
H  
I  
J  
L  
M

WW

# FRONT WIPER AND WASHER SYSTEM

## 3. IPDM E/R INSPECTION

Ⓜ With CONSULT-II

1. Connect IPDM E/R connector and front wiper motor connector.
2. Turn ignition switch ON.
3. Select "HI" on "ACTIVE TEST" screen.
4. When front wiper high relay is operating, check voltage between IPDM E/R terminals.

ⓧ Without CONSULT-II

1. Connect IPDM E/R connector and front wiper motor connector.
2. Turn on front wipers using the auto active test. Refer to [PG-22, "Auto Active Test"](#).
3. When front wiper high relay is operating, check voltage between IPDM E/R terminals.

IPDM E/R				Voltage (Approx.)
(-)		(+)		
Connector	Terminal	Connector	Terminal	Battery voltage
E122	38	E121	35	
E124	59			

OK or NG

- OK >> Replace the wiper motor. Refer to [WW-26, "REMOVAL AND INSTALLATION"](#).
- NG >> Replace IPDM E/R. Refer to [PG-30, "Removal and Installation of IPDM E/R"](#).

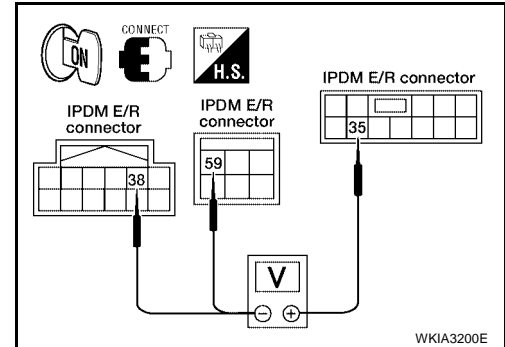

## 4. COMBINATION SWITCH TO BCM INSPECTION

Select "BCM" on CONSULT-II. With "WIPER" data monitor, check that "FR WIPER HI" turns ON-OFF according to operation of wiper switch.

OK or NG

- OK >> Replace BCM. Refer to [BCS-26, "Removal and Installation"](#).
- NG >> Replace wiper switch. Refer to [WW-27, "REMOVAL AND INSTALLATION"](#).

DATA MONITOR	
MONITOR	
IGN ON SW	OFF
IGN SW CAN	ON
FR WIPER HI	OFF
FR WIPER LOW	OFF
FR WIPER INT	OFF
FR WASHER SW	OFF
INT VOLUME	7
FR WIPER STOP	ON
VEHICLE SPEED	0.0 km/h
PAGE DOWN	
RECORD	
MODE	BACK
LIGHT	COPY

### Only Front Wiper Intermittent Does Not Operate

#### 1. COMBINATION SWITCH TO BCM INSPECTION

Select "BCM" on CONSULT-II. With "WIPER" data monitor, check that "FR WIPER INT" turns ON-OFF according to operation of wiper switch.

OK or NG

- OK >> Replace BCM. Refer to [BCS-26, "Removal and Installation"](#).
- NG >> Replace wiper switch. Refer to [WW-27, "REMOVAL AND INSTALLATION"](#).

DATA MONITOR	
MONITOR	
IGN ON SW	OFF
IGN SW CAN	ON
FR WIPER HI	OFF
FR WIPER LOW	OFF
FR WIPER INT	OFF
FR WASHER SW	OFF
INT VOLUME	7
FR WIPER STOP	ON
VEHICLE SPEED	0.0 km/h
PAGE DOWN	
RECORD	
MODE	BACK
LIGHT	COPY

# FRONT WIPER AND WASHER SYSTEM

## Front Wiper Intermittent Operation Switch Position Cannot Be Adjusted

EKS00J24

### 1. COMBINATION SWITCH TO BCM INSPECTION

Select "BCM" on CONSULT-II. With "WIPER" data monitor, check that "INT VOLUME" changes in order from 1 to 7 according to operation of the intermittent switch dial position.

OK or NG

- OK >> Replace BCM. Refer to [BCS-26, "Removal and Installation"](#).
- NG >> Replace wiper switch. Refer to [WW-27, "REMOVAL AND INSTALLATION"](#).

DATA MONITOR	
MONITOR	
IGN ON SW	OFF
IGN SW CAN	ON
FR WIPER HI	OFF
FR WIPER LOW	OFF
FR WIPER INT	OFF
FR WASHER SW	OFF
INT VOLUME	7
FR WIPER STOP	ON
VEHICLE SPEED	0.0 km/h
PAGE DOWN	
RECORD	
MODE	BACK
LIGHT	COPY

WKIA1018E

## Wipers Do Not Wipe When Front Washer Operates

EKS00J25

### 1. COMBINATION SWITCH TO BCM INSPECTION

Select "BCM" on CONSULT-II. With "WIPER" data monitor, check that "FR WASHER SW" turns ON-OFF according to operation of front washer switch.

OK or NG

- OK >> Replace BCM. Refer to [BCS-26, "Removal and Installation"](#).
- NG >> Replace wiper switch. Refer to [WW-27, "REMOVAL AND INSTALLATION"](#).

DATA MONITOR	
MONITOR	
IGN ON SW	OFF
IGN SW CAN	ON
FR WIPER HI	OFF
FR WIPER LOW	OFF
FR WIPER INT	OFF
FR WASHER SW	OFF
INT VOLUME	7
FR WIPER STOP	ON
VEHICLE SPEED	0.0 km/h
PAGE DOWN	
RECORD	
MODE	BACK
LIGHT	COPY

WKIA1018E

## Front Wipers Operate For 10 Seconds, Stop For 20 Seconds, And After Repeating This Operation Five Times, They Become Inoperative

EKS00J26

### CAUTION:

- When auto stop signal has not varied for 10 seconds or longer while IPDM E/R is operating front wipers, IPDM E/R considers front wipers locked and stops wiper output, which causes this symptom.
- This status can be checked by using IPDM E/R "DATA MONITOR". Under this condition, "WIP PROT" reads "BLOCK".

### 1. CHECK IPDM E/R TO FRONT WIPER MOTOR

☑ With CONSULT-II

Select "IPDM E/R" with CONSULT-II. With "DATA MONITOR", confirm that "WIP AUTO STOP" changes from "ACT P" to "STOP P" according to wiper operation.

☒ Without CONSULT-II

GO TO 2.

OK or NG

- OK >> Replace IPDM E/R. Refer to [PG-30, "Removal and Installation of IPDM E/R"](#).
- NG >> GO TO 2.

DATA MONITOR	
MONITOR	
MOTOR FAN REQ	1
AC COMP REQ	OFF
TAIL&CLR REQ	OFF
HL LO REQ	OFF
HL HI REQ	OFF
FR FOG REQ	OFF
FR WIP REQ	STOP
WIP AUTO STOP	STOP P
WIP PROT	OFF
Page DOWN	
RECORD	
MODE	BACK
LIGHT	COPY

SKIA5301E

# FRONT WIPER AND WASHER SYSTEM

## 2. IPDM E/R TO FRONT WIPER MOTOR AUTO STOP CIRCUIT INSPECTION

1. Turn ignition switch OFF.
2. Disconnect IPDM E/R connector and front wiper motor connector.
3. Check continuity between IPDM E/R harness connector terminal and front wiper motor harness connector terminal.

IPDM E/R		Front wiper motor		Continuity
Connector	Terminal	Connector	Terminal	
E122	43	E23	6	Yes

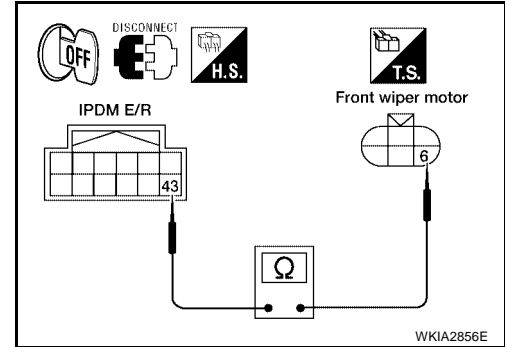

4. Check continuity between IPDM E/R harness connector terminal and ground.

IPDM E/R			Continuity
Connector	Terminal		
E122	43	Ground	No

**OK or NG**

- OK >> Connect connectors. GO TO 3.
- NG >> Repair harness or connector.

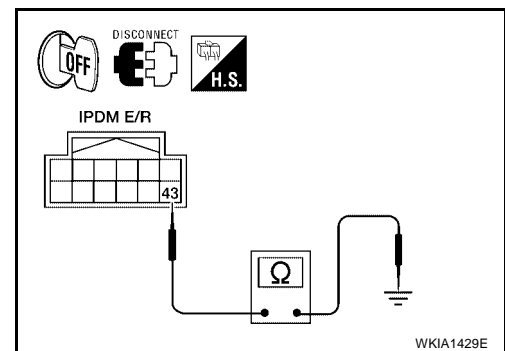

## 3. IPDM E/R TO FRONT WIPER MOTOR AUTO STOP CIRCUIT VOLTAGE

1. Turn ignition switch ON.
2. While front wiper motor is stopped and while operating, measure voltage between IPDM E/R terminal 43 and ground.

IPDM E/R		(-)	Condition	Voltage (Approx.)
( + )				
Connector	Terminal			
E122	43	Ground	Wiper operating	Battery voltage
			Wiper stopped	0V

**OK or NG**

- OK >> Replace IPDM E/R. Refer to [PG-30, "Removal and Installation of IPDM E/R"](#) .
- NG >> Replace front wiper motor. Refer to [WW-26, "REMOVAL AND INSTALLATION"](#) .

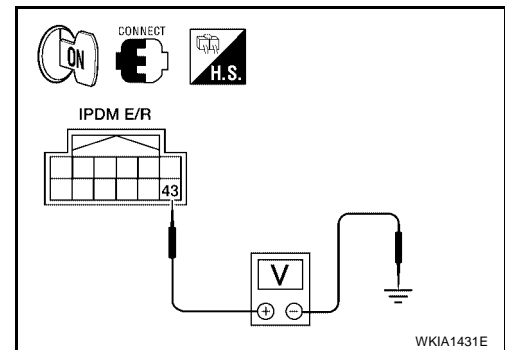



# FRONT WIPER AND WASHER SYSTEM

EKS00J27

## Front Wiper Arms REMOVAL AND INSTALLATION

### Removal

1. Remove wiper arm covers and wiper arm nuts.
2. Remove front RH wiper arm and front LH wiper arm.
3. Remove front RH blade assembly and front LH blade assembly.

### Installation

1. Operate wiper motor one full cycle, then turn "OFF" (Auto Stop).
2. Clean up the pivot area as shown. This will reduce possibility of wiper arm looseness.

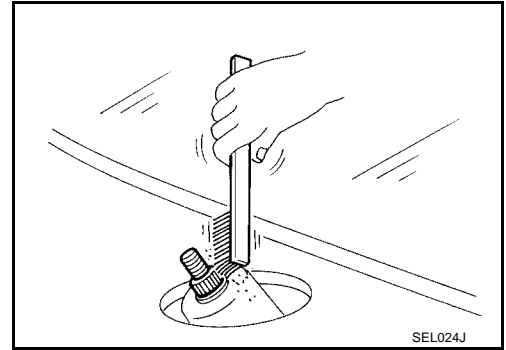

3. Install front RH blade assembly and front LH blade assembly.
4. Install front RH wiper arm and front LH wiper arm.
5. Tighten wiper arm nuts to specified torque, and install wiper arm covers. Refer to [WW-26, "Wiper Motor and Linkage"](#).
6. Ensure that wiper blades stop within proper clearance. Refer to [WW-25, "FRONT WIPER ARM ADJUSTMENT"](#).

## FRONT WIPER ARM ADJUSTMENT

1. Operate wiper motor one full cycle, then turn "OFF" (Auto Stop).
2. Lift the wiper blade up and then rest it onto glass surface, check the blade clearance "L1" and "L2".

**Clearance "L1" : 41.5 - 56.5 mm (1.634 - 2.224 in)**

**Clearance "L2" : 52.5 - 67.5 mm (2.067 - 2.657 in)**

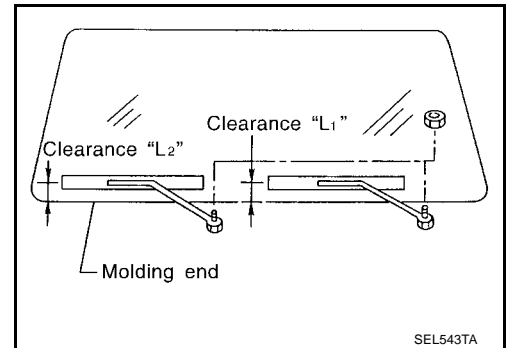

3. Remove wiper arm covers and wiper arm nuts.
4. Adjust front wiper arms on wiper motor pivot shafts to obtain above specified blade clearances.
5. Tighten wiper arm nuts to specified torque, and install wiper arm covers. Refer to [WW-26, "Wiper Motor and Linkage"](#).

# FRONT WIPER AND WASHER SYSTEM

EKS00J28

## Wiper Motor and Linkage REMOVAL AND INSTALLATION

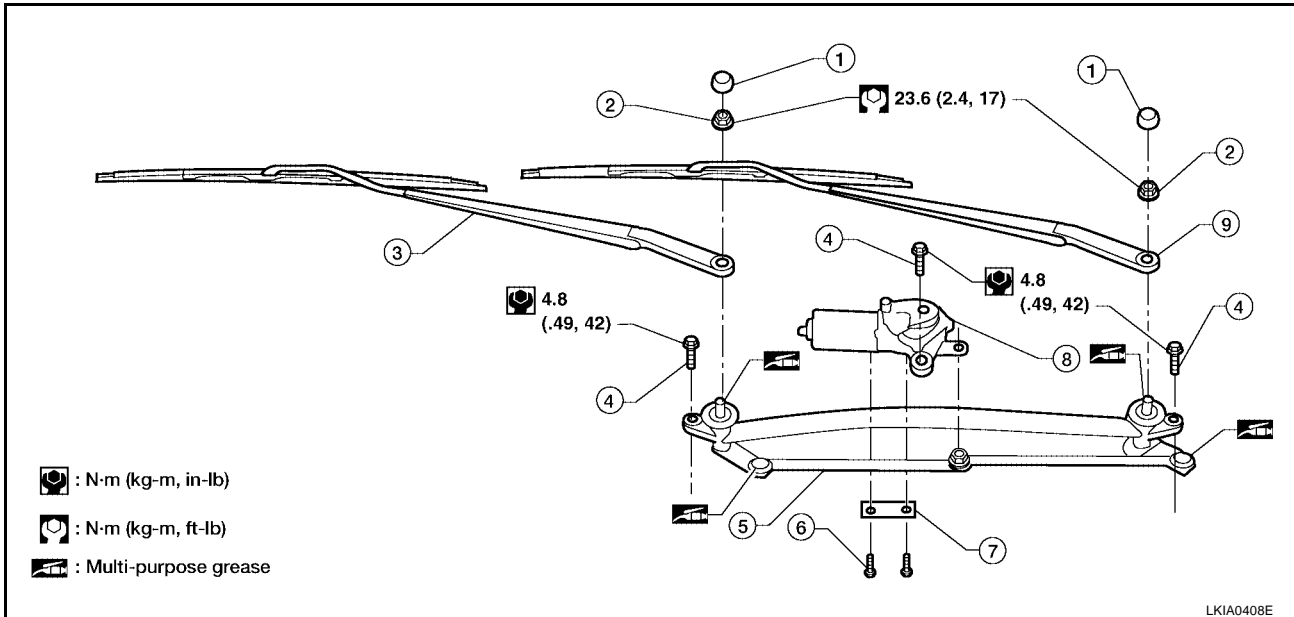

- |                       |                         |  |
|-----------------------|-------------------------|--|
| 1. Wiper arm covers   | 2. Wiper arm nuts       | 3. Front RH wiper arm and blade assembly |
| 4. Wiper frame bolts  | 5. Wiper frame assembly | 6. Wiper motor to frame bolts            |
| 7. Wiper motor spacer | 8. Wiper motor          | 9. Front LH wiper arm and blade assembly |

### REMOVAL

1. Remove the cowl top. Refer to [EI-18, "COWL TOP"](#).
2. Remove wiper frame bolts and remove wiper frame assembly.
3. Remove wiper motor from wiper frame assembly.

### INSTALLATION

#### CAUTION:

- Do not drop the wiper motor or cause it to contact other parts.
  - Check the grease conditions of the motor arm and wiper link joint(s). Apply grease if necessary.
1. Connect wiper motor to connector. Turn the wiper switch ON to operate wiper motor, then turn the wiper switch OFF (auto stop).
  2. Disconnect wiper motor connector.
  3. Install wiper motor to wiper frame assembly, and install wiper frame assembly.
  4. Install cowl top. Refer to [EI-18, "COWL TOP"](#).
  5. Ensure that wiper blades stop within proper clearance. Refer to front wiper arm adjustment [WW-25, "FRONT WIPER ARM ADJUSTMENT"](#).

### Washer Nozzle Adjustment

EKS00J29

- This vehicle is equipped with non-adjustable washer nozzles.
- If not satisfied with washer fluid spray coverage, confirm that the washer nozzle is installed correctly.
- If the washer nozzle is installed correctly, and the washer fluid spray coverage is not satisfactory, replace washer nozzle.

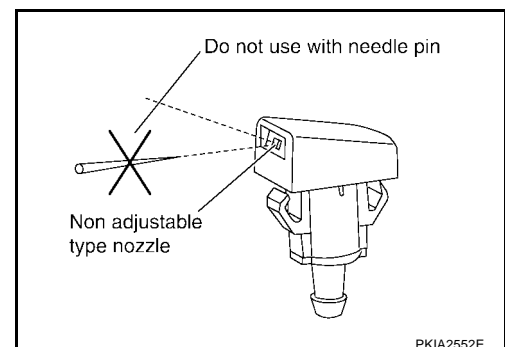

# FRONT WIPER AND WASHER SYSTEM

## Washer Tube Layout

EKS00J2A

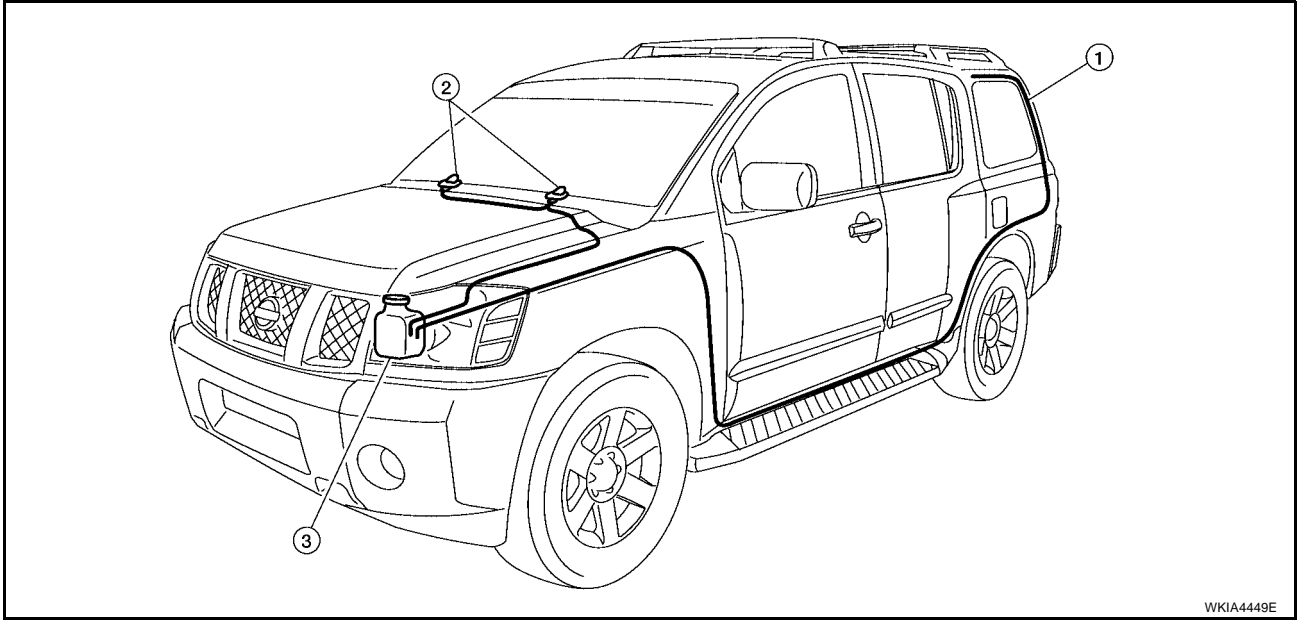

1. Rear washer nozzle

2. Washer nozzles

3. Washer fluid reservoir

## Wiper and Washer Switch REMOVAL AND INSTALLATION

EKS00J2B

### Removal

1. Remove steering column covers.
2. Remove wiper washer switch connector.
3. Pinch tabs at wiper and washer switch base and slide switch away from steering column to remove.

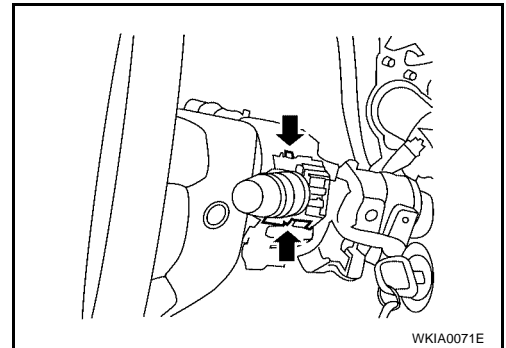

### INSTALLATION

Installation is in the reverse order of removal.

## Washer Fluid Reservoir REMOVAL AND INSTALLATION

EKS00J2C

### Removal

1. Remove side washer fluid reservoir screw.

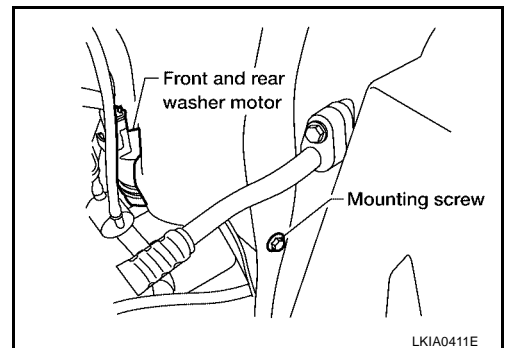

# FRONT WIPER AND WASHER SYSTEM

2. Remove front and rear washer motor connector.
3. Remove washer fluid level sensor connector.
4. Disconnect front and rear washer hoses.

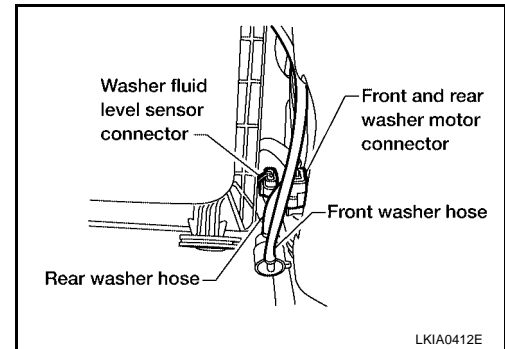

5. Remove front washer fluid reservoir screw (2).
6. Remove washer fluid reservoir from the vehicle (1).

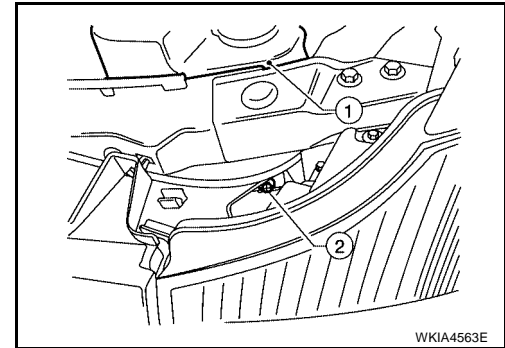

## Installation

Installation is in the reverse order of removal.

### CAUTION:

After installation, add water up to the upper level of the washer fluid reservoir inlet and check for water leaks.

## Washer Motor REMOVAL AND INSTALLATION

EKS00J2D

### Removal

1. Remove washer fluid reservoir. Refer to [WW-27, "Washer Fluid Reservoir"](#).
2. Remove washer motor (1) in the direction of the arrow as shown from washer fluid reservoir (2).

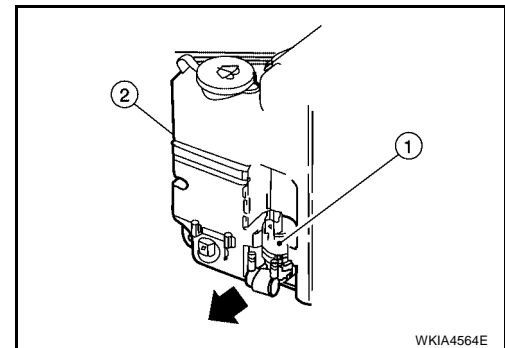

## INSTALLATION

Installation is in the reverse order of removal.

### CAUTION:

When installing front and rear washer motor, there should be no packing twists, etc.

# REAR WIPER AND WASHER SYSTEM

PFP:28710

EKS00J2E

## REAR WIPER AND WASHER SYSTEM

### Components Parts and Harness Connector Location

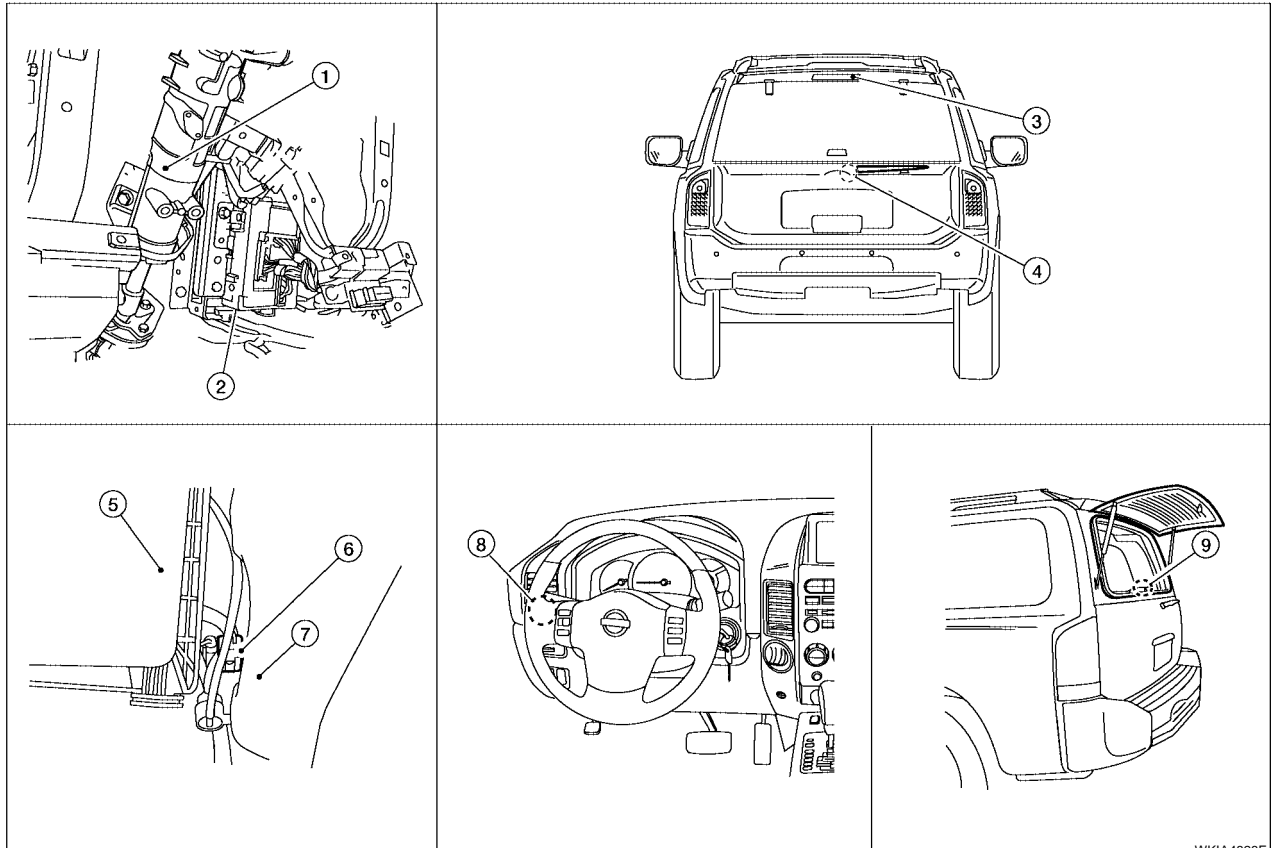

- |   |   |   |
|---|---|---|
| 1. Steering column (view with instrument panel removed) | 2. BCM (view with instrument panel removed) M18, M19, M20 | 3. Rear washer nozzle                         |
| 4. Rear wiper motor D507                                | 5. Air cleaner case                                       | 6. Front and rear washer motor connector E105 |
| 7. Washer fluid reservoir                               | 8. Combination switch M28                                 | 9. Glass hatch ajar switch D707               |

### System Description

EKS00J2F

- The wiper switch (combination switch) is composed of a combination of 5 output terminals and 5 input terminals. Terminal combination status is read by the BCM (body control module) when switch is turned ON.
- The BCM controls rear wiper ON and INT (intermittent) operation.

Power is supplied at all times

- through 50A fusible link (letter f , located in fuse and fusible link box)
- to BCM terminal 70.

With the ignition switch in ON or START position, power is supplied

- through 10A fuse [No. 9, located in fuse block (J/B)]
- to combination switch terminal 14, and
- through 10A fuse (No. 59, located in the fuse and relay box)
- to BCM terminal 38.

Ground is supplied

- to BCM terminal 67 and
- to combination switch terminal 12
- through grounds M57, M61 and M79.

A  
B  
C  
D  
E  
F  
G  
H  
I  
J  
L  
M

WW

# REAR WIPER AND WASHER SYSTEM

## REAR WIPER OPERATION

When the ignition switch is in the ON or START position, and the rear wiper switch is in the ON position, the BCM detects a rear wiper ON request through the combination switch (wiper switch) reading function.

The BCM will first check the status of the glass hatch ajar switch before supplying power to the rear wiper motor. If the glass hatch ajar switch is closed (ground) the BCM will not turn on the rear wiper motor. If the glass hatch ajar switch is open (not grounded) the BCM will control the rear wiper motor as follows.

The BCM controls rear wiper motor operation by switching direction of current flow between the two rear wiper motor output circuits.

Power is supplied to output circuit 1 for forward operation (counterclockwise sweep),

- through BCM terminal 55
- to rear wiper motor terminal 4.

Ground is supplied

- to rear wiper motor terminal 6
- through BCM terminal 54
- through BCM terminal 67
- through grounds M57, M61 and M79.

With output circuit 1 power and ground supplied, the rear wiper motor operates in a counterclockwise sweep direction until auto stop switch 1 closes (full sweep position). Auto stop switch 1 supplies ground

- to BCM terminal 44
- through rear wiper motor terminal 2
- through rear wiper motor terminal 5
- through grounds B117 and B132.

When the BCM receives this ground signal it turns off output circuit 1 and turns on output circuit 2.

Power is supplied to output circuit 2 for reverse operation (clockwise sweep),

- through BCM terminal 54
- to rear wiper motor terminal 6.

Ground is supplied

- to rear wiper motor terminal 4
- through BCM terminal 55
- through BCM terminal 67
- through grounds M57, M61 and M79.

With output circuit 2 power and ground supplied the rear wiper motor operates in a clockwise sweep direction until auto stop switch 2 closes (full sweep position). Auto stop switch 2 supplies ground

- to BCM terminal 26
- through rear wiper motor terminal 1
- through rear wiper motor terminal 3
- through grounds B117 and B132.

When the BCM receives this ground signal it turns off output circuit 2 and turns on output circuit 1. This process repeats until the rear wiper switch or ignition switch is turned off.

If the ignition switch is turned to OFF during operation, the rear wiper motor will immediately stop. If the ignition switch is turned ON after this condition, and the BCM does not receive a rear wiper switch ON or INT signal, the BCM will operate the rear wiper to the auto stop position.

If the BCM does not receive a change in status in either auto stop switch 1 or auto stop switch 2 within a 5 second period of output circuit 1 or output circuit 2 operation, the BCM will turn off output circuit 1 and output circuit 2.

If the BCM detects the rear door glass ajar signal during rear wiper motor operation, the BCM will operate the rear wiper motor to the auto stop position. Once the rear door glass ajar signal returns to open (not grounded) for 5 or more seconds, the BCM will resume rear wiper motor operation.

## INTERMITTENT OPERATION

The rear wiper motor operates the wiper arm at low speed approximately every 7 seconds.

When the wiper switch is in the rear wiper INT position, the BCM detects a rear wiper INT request through the combination switch (wiper switch) reading function.

# REAR WIPER AND WASHER SYSTEM

The BCM controls rear wiper motor operation by switching direction of current flow between the two rear wiper motor output circuits.

Power is supplied to output circuit 1 for forward operation (counterclockwise sweep),

- through BCM terminal 55
- to rear wiper motor terminal 4.

Ground is supplied

- to rear wiper motor terminal 6
- through BCM terminal 54
- through BCM terminal 67
- through grounds M57, M61 and M79.

With output circuit 1 power and ground supplied, the rear wiper motor operates in a counterclockwise sweep direction until auto stop switch 1 closes (full sweep position). Auto stop switch 1 supplies ground

- to BCM terminal 44
- through rear wiper motor terminal 2
- through rear wiper motor terminal 5
- through grounds B117 and B132.

When the BCM receives this ground signal it turns off output circuit 1 and turns on output circuit 2.

Power is supplied to output circuit 2 for reverse operation (clockwise sweep),

- through BCM terminal 54
- to rear wiper motor terminal 6.

Ground is supplied

- to rear wiper motor terminal 4
- through BCM terminal 55
- through BCM terminal 67
- through grounds M57, M61 and M79.

With output circuit 2 power and ground supplied the rear wiper motor operates in a clockwise sweep direction until auto stop switch 2 closes (full sweep position). Auto stop switch 2 supplies ground

- to BCM terminal 26
- through rear wiper motor terminal 1
- through rear wiper motor terminal 3
- through grounds B117 and B132.

When the BCM receives this ground signal it turns off output circuit 2 and starts the timing function of 7 seconds. After approximately 7 seconds the BCM turns on output circuit 1. This process repeats until the rear wiper switch or ignition switch is turned off.

## AUTO STOP OPERATION

When the rear wiper switch is turned off, the BCM will continue the cycle of output circuit 1 or output circuit 2 until auto stop switch 1 and auto stop switch 2 are both in the closed position. When the BCM receives ground signals from auto stop switch 1 and auto stop switch 2 simultaneously, output circuit 1 and output circuit 2 are both turned off.

## REAR WASHER OPERATION

When the ignition switch is in the ON or START position, and the front and rear washer switches are OFF, the front and rear washer motor is supplied power

- through 10A fuse (No. 9, located in the fuse block J/B)
- through combination switch (wiper switch) terminal 14
- through combination switch (wiper switch) terminal 11
- to front and rear washer motor terminal 2, and
- through combination switch (wiper switch) terminal 13
- to front and rear washer motor terminal 1.

When the rear wiper switch is in rear washer position, the BCM detects a rear washer signal by BCM wiper switch reading function. Combination switch ground is supplied

- to front and rear washer motor terminal 1

A

B

C

D

E

F

G

H

I

J

WW

L

M

## REAR WIPER AND WASHER SYSTEM

---

- through combination switch (wiper switch) terminal 13
- through combination switch (wiper switch) terminal 12
- through grounds M57, M61 and M79.

With ground supplied, the front and rear washer motor is operated in the rear direction.

When the BCM detects that the rear washer motor has operated for 0.4 seconds or longer, BCM operates the rear wiper motor.

When the BCM detects that the rear washer switch is in OFF, the rear wiper motor cycles approximately 3 times and then stops.

If the rear washer is operated with the rear wiper switch in the INT position, normal rear wiper operation will take over. Once the rear washer switch is released the rear wiper will return to INT operation.

### **BCM WIPER SWITCH READING FUNCTION**

Refer to [BCS-3, "COMBINATION SWITCH READING FUNCTION"](#) .



# REAR WIPER AND WASHER SYSTEM

## Wiring Diagram — WIP/ R —

EKS00J2G

WW-WIP/R-01

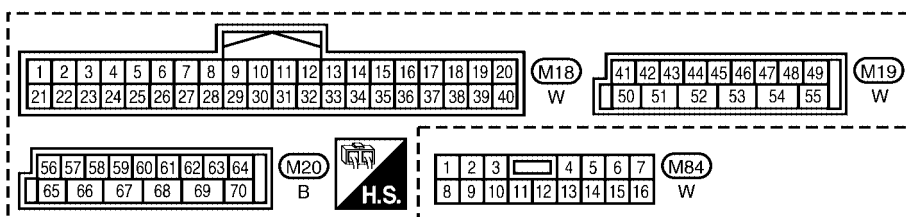
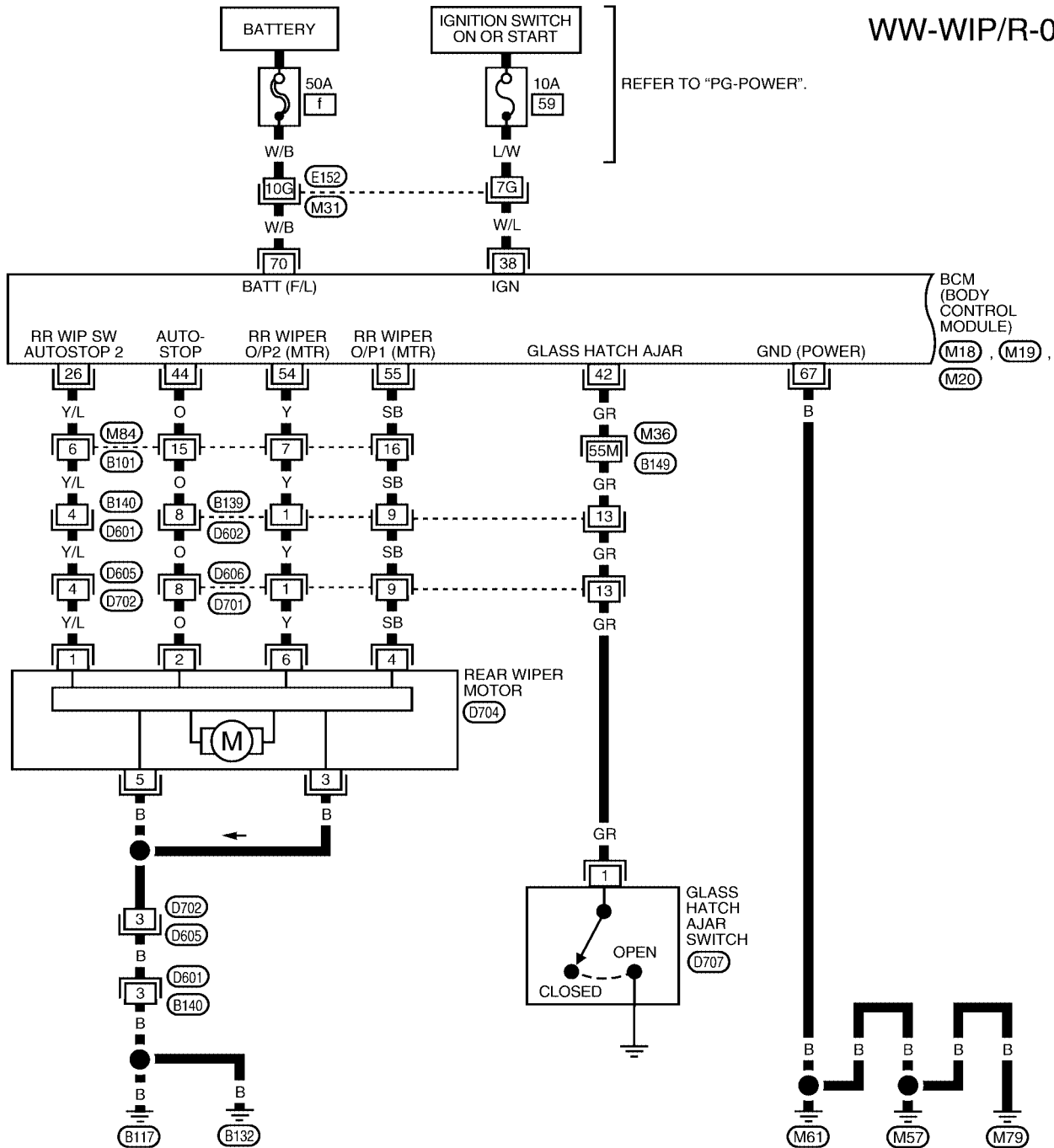

REFER TO THE FOLLOWING.  
**(M31), (M36)** - SUPER MULTIPLE JUNCTION (SMJ)

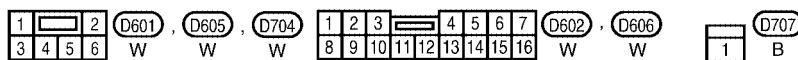

WKWA2266E

# REAR WIPER AND WASHER SYSTEM

WW-WIP/R-02

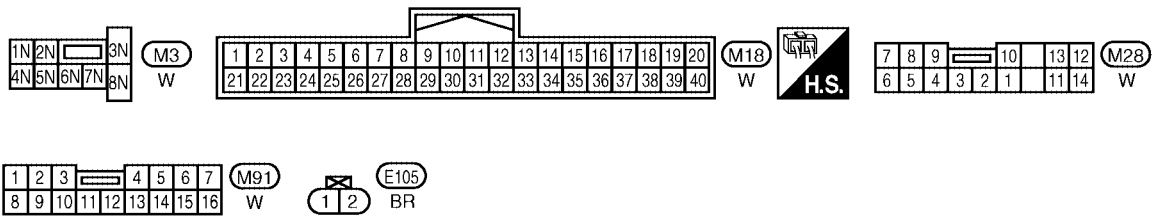
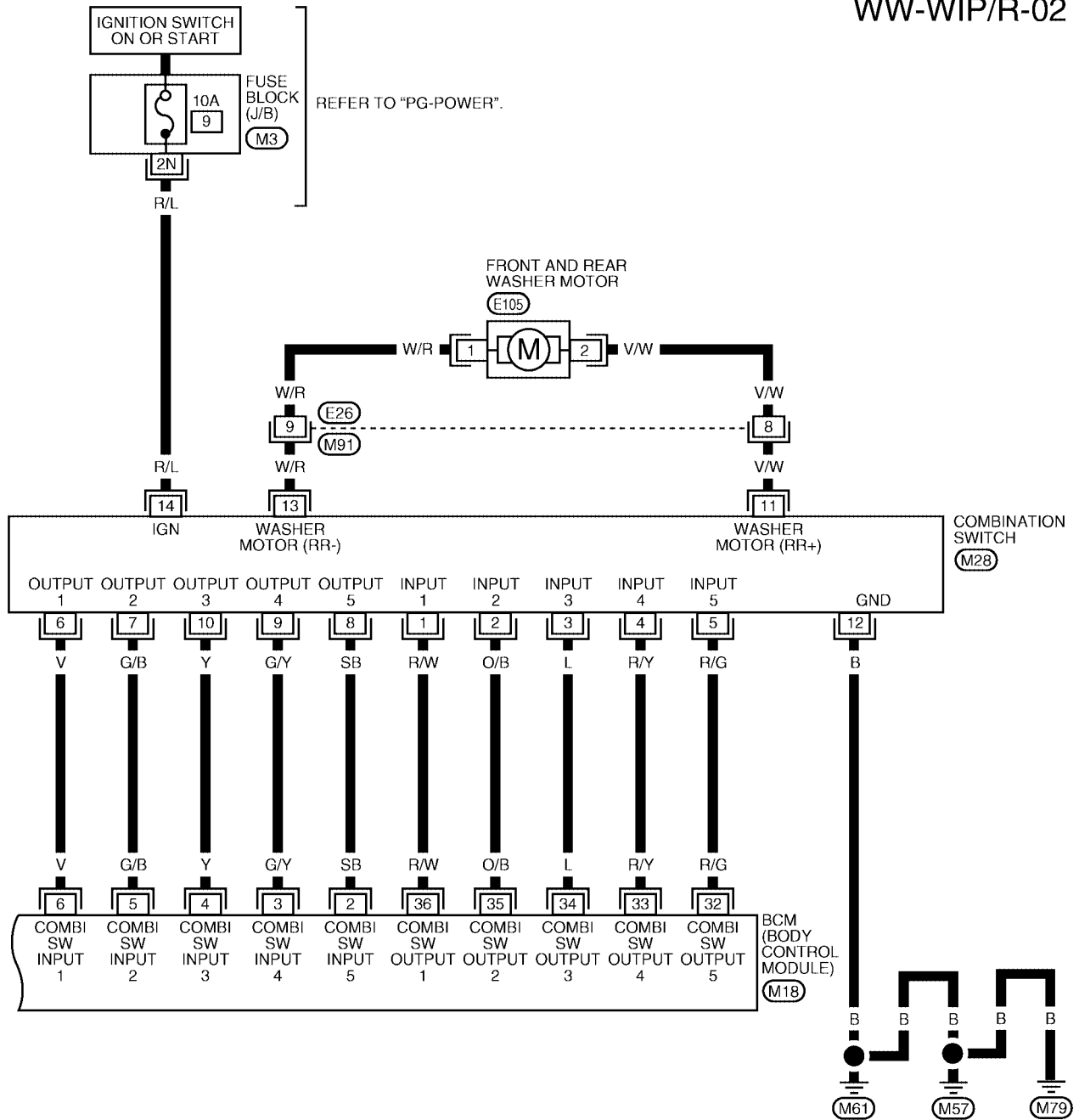

WKWA3524E

# REAR WIPER AND WASHER SYSTEM

## Terminals and Reference Values for BCM

EKS00J2H

Refer to [BCS-12, "Terminals and Reference Values for BCM"](#) .

## How to Proceed With Trouble Diagnosis

EKS00J2I

1. Confirm the symptoms and customer complaint.
2. Understand operation description and function description. Refer to [WW-29, "System Description"](#) .
3. Perform the Preliminary Check. Refer to [WW-35, "Preliminary Check"](#) .
4. Check symptom and repair or replace the cause of malfunction.
5. Does the rear wiper operate normally? If YES: GO TO 6. If NO: GO TO 4.
6. Inspection End.

## Preliminary Check

EKS00J2J

### INSPECTION FOR POWER SUPPLY AND GROUND CIRCUIT

Refer to [BCS-17, "BCM Power Supply and Ground Circuit Check"](#) .

## CONSULT-II Function (BCM)

EKS00J2K

CONSULT-II can display each diagnostic item using the diagnostic test modes shown following.

BCM diagnostic test item	Diagnostic mode	Description
Inspection by part	WORK SUPPORT	Supports inspections and adjustments. Commands are transmitted to the BCM for setting the status suitable for required operation, input/output signals are received from the BCM and received data is displayed.
	DATA MONITOR	Displays BCM input/output data in real time.
	ACTIVE TEST	Operation of electrical loads can be checked by sending drive signal to them.
	SELF-DIAG RESULTS	Displays BCM self-diagnosis results.
	CAN DIAG SUPPORT MNTR	The result of transmit/receive diagnosis of CAN communication can be read.
	ECU PART NUMBER	BCM part number can be read.
	CONFIGURATION	Performs BCM configuration read/write functions.

## CONSULT-II START PROCEDURE

Refer to [GI-38, "CONSULT-II Start Procedure"](#) .

WW

## DATA MONITOR

### Display Item List

Monitor item name "OPERATION OR UNIT"	Contents
IGN ON SW "ON/OFF"	Displays "IGN Position (ON)/OFF, ACC Position (OFF)" status as judged from ignition switch signal.
IGN SW CAN "ON/OFF"	Displays "IGN Position (ON)/OFF, ACC Position (OFF)" status as judged from CAN communications.
FR WIPER INT "ON/OFF"	Displays "Front Wiper INT (ON)/Other (OFF)" status as judged from wiper switch signal.
FR WIPER LOW "ON/OFF"	Displays "Front Wiper LOW (ON)/Other (OFF)" status as judged from wiper switch signal.
FR WIPER HI "ON/OFF"	Displays "Front Wiper HI (ON)/Other (OFF)" status as judged from wiper switch signal.
FR WASHER SW "ON/OFF"	Displays "Front Washer Switch (ON)/Other (OFF)" status as judged from wiper switch signal.
INT VOLUME (1 - 7)	Displays intermittent operation dial position setting (1 - 7) as judged from wiper switch signal.
VEHICLE SPEED "0.0 km/h"	Displays vehicle speed as received over CAN communication.
FR WIPER STOP "ON/OFF"	Displays "Stopped (ON)/Operating (OFF)" status as judged from the auto stop signal.
RR WIPER INT "ON/OFF"	Displays "Rear Wiper INT (ON)/Other (OFF)" status as judged from wiper switch signal.
RR WIPER ON "ON/OFF"	Displays "Rear Wiper (ON)/Other (OFF)" status as judged from wiper switch signal.
RR WASHER SW "ON/OFF"	Displays "Rear Washer Switch (ON)/Other (OFF)" status as judged from wiper switch signal.

# REAR WIPER AND WASHER SYSTEM

Monitor item name "OPERATION OR UNIT"	Contents
RR WIPER STOP "ON/OFF"	Displays "Stopped (OFF)/Operating (ON)" status as judged from the auto stop switch 1.
RR AUTO STP 2 "ON/OFF"	Displays "Stopped (OFF)/Operating (ON)" status as judged from the auto stop switch 2.

## ACTIVE TEST

### Display Item List

Test item	Display on CONSULT-II screen	Description
Front wiper HI output	FR WIPER (HI)	Front wiper HI can be operated by any ON-OFF operation.
Front wiper LO output	FR WIPER (LO)	Front wiper LO can be operated by any ON-OFF operation.
Front wiper INT output	FR WIPER (INT)	Front wiper INT can be operated by any ON-OFF operation.
Rear wiper output	RR WIPER	Rear wiper can be operated by any ON-OFF operation.

## Rear Wiper Does Not Operate

EKS00JZL

### 1. REAR WIPER ACTIVE TEST

1. Select "BCM" on CONSULT-II, and select "WIPER" on "SELECT TEST ITEM" screen.
2. Select "ACTIVE TEST" on "SELECT DIAG MODE" screen.
3. Select "RR WIPER" on "SELECT TEST ITEM" screen.
4. Make sure rear wiper operates.

**Wiper should operate.**

OK or NG

- OK >> GO TO 7.  
 NG >> GO TO 2.

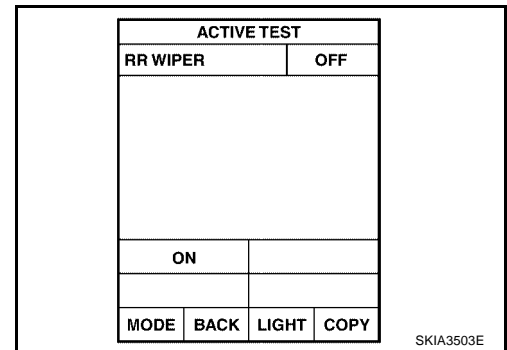

### 2. CHECK REAR WIPER MOTOR CIRCUITS

1. Turn ignition switch OFF.
2. Disconnect BCM connector and rear wiper motor connector.
3. Check continuity between BCM harness connector terminals and rear wiper motor harness connector terminals.

BCM		Rear wiper motor		Continuity
Connector	Terminal	Connector	Terminal	
M19	55	D704	4	Yes
	54		6	

OK or NO

- OK >> GO TO 3.  
 NO >> Repair harness or connector.

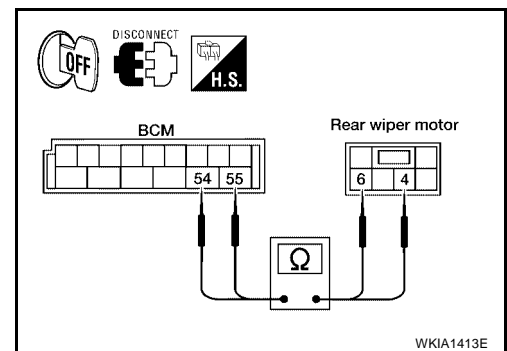

# REAR WIPER AND WASHER SYSTEM

## 3. CHECK GLASS HATCH AJAR SWITCH

1. Make sure hatch glass is closed.
2. Check continuity between BCM connector M19 terminal 42 and ground.

**42 - Ground : Continuity should not exist.**

OK or NG

OK >> GO TO 4.

NG >> Repair harness if shorted. If not, refer to [BL-78, "Diagnostic Procedure 1"](#) for further glass hatch ajar switch diagnosis.

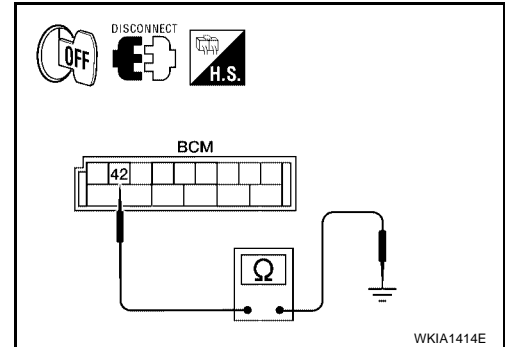

## 4. CHECK REAR WIPER MOTOR AUTO STOP CIRCUITS

1. Disconnect BCM connector M18.
2. Check continuity between BCM harness connector terminals and rear wiper motor harness connector terminals.

BCM		Rear wiper motor		Continuity
Connector	Terminal	Connector	Terminal	
M18	26	D704	1	Yes
M19	44		2	

OK or NO

OK >> GO TO 5.

NO >> Repair harness or connector.

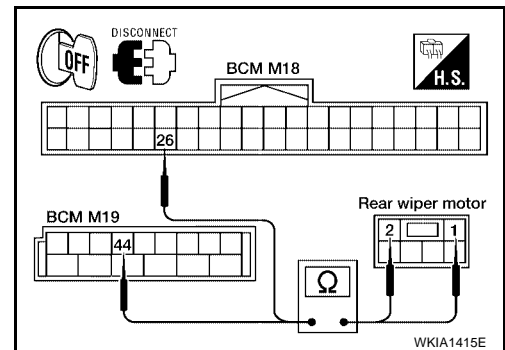

## 5. CHECK REAR WIPER MOTOR AUTO STOP SWITCH GROUNDS

Check continuity between rear wiper motor harness connector D704 terminals and ground.

Rear wiper motor		Continuity
Connector	Terminal	
D704	3	Ground Yes
	5	

OK or NG

OK >> GO TO 6.

NG >> Repair harness or connector.

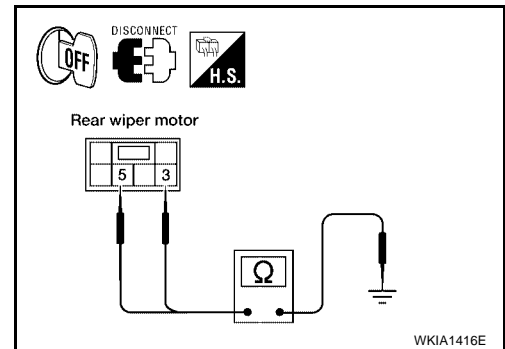

A  
B  
C  
D  
E  
F  
G  
H  
I  
J  
L  
M

WW

# REAR WIPER AND WASHER SYSTEM

## 6. CHECK REAR WIPER OPERATING

1. Connect BCM connectors and rear wiper motor connector.
2. Turn ignition switch ON.
3. Select "RR WIPER" during "ACTIVE TEST". Refer to [WW-36, "ACTIVE TEST"](#) . When rear wiper is operating, check voltage between BCM connector terminals and ground.

BCM		(-)	Condition	Voltage (Approx.)
(+) Connector Terminal				
M19	54	Ground	Operating	Fluctuating
	55		End of travel (stopped)	0V

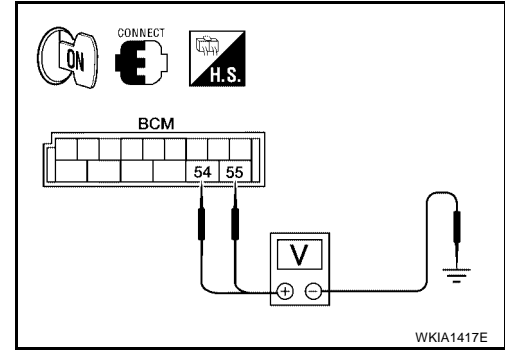

OK or NG

- OK >> Replace rear wiper motor. Refer to [WW-43, "REMOVAL AND INSTALLATION"](#) .
- NG >> Replace BCM. Refer to [BCS-26, "Removal and Installation"](#) .

## 7. CHECK COMBINATION SWITCH INPUT SIGNAL

Select "BCM" on CONSULT-II. With "WIPER" data monitor, make sure "RR WIPER INT", "RR WIPER ON" turn ON-OFF according to operation of wiper switch.

- When wiper switch is in INT position : RR WIPER INT ON**
- When wiper switch is in ON position : RR WIPER ON**

OK or NG

- OK >> Replace BCM. Refer to [BCS-26, "Removal and Installation"](#) .
- NG >> Check the wiper switch. Refer to [BCS-3, "COMBINATION SWITCH READING FUNCTION"](#) .

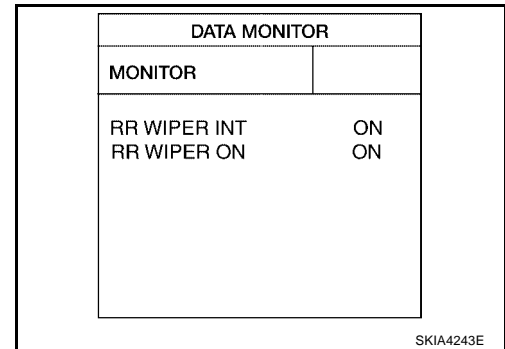

# REAR WIPER AND WASHER SYSTEM

EKS00J2M

## Rear Wiper Stop Position Is Incorrect

### 1. CHECK AUTO STOP SWITCH INPUT SIGNALS

Select "BCM" on CONSULT-II. With "WIPER" data monitor, make sure "RR WIPER STOP" and "RR AUTO STOP 2" turn ON-OFF according to wiper operation.

- When wiper switch is OFF : RR WIPER STOP ON  
and arm on stop : RR AUTO STOP 2 ON
- When wiper switch is ON : RR WIPER STOP OFF  
and arm in position A : RR AUTO STOP 2 ON
- When wiper switch is ON : RR WIPER STOP OFF  
counterclockwise sweep : RR AUTO STOP 2 OFF
- When wiper switch is ON : RR WIPER STOP ON  
and arm in position B : RR AUTO STOP 2 OFF
- When wiper switch is ON : RR WIPER STOP OFF  
clockwise sweep : RR AUTO STOP 2 OFF
- When wiper switch is ON : RR WIPER STOP ON  
and arm in position A : RR AUTO STOP 2 OFF

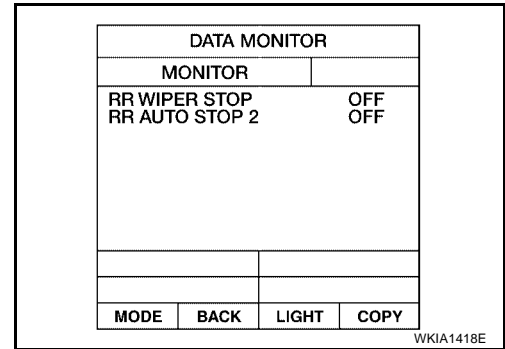

OK or NG

- OK >> Replace BCM. Refer to [BCS-26, "Removal and Installation"](#).
- NG >> GO TO 2.

### 2. CHECK AUTO STOP CIRCUITS FOR SHORT TO GROUND

- Turn ignition switch to OFF.
- Disconnect BCM and rear wiper motor connectors.
- Check continuity between BCM harness connector terminals and ground.

BCM		Continuity
Connector	Terminal	
M18	26	Ground No
M19	44	

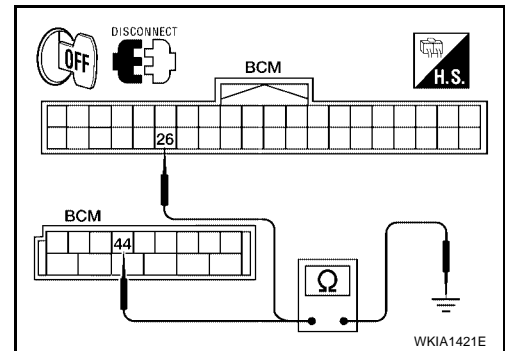

OK or NO

- OK >> GO TO 3.
- NO >> Repair harness or connector.

### 3. CHECK REAR WIPER MOTOR AUTO STOP SWITCH GROUNDS

Check continuity between rear wiper motor harness connector D704 terminals and ground.

Rear wiper motor		Continuity
Connector	Terminal	
D704	1	Ground No
	2	
	3	Yes
	5	

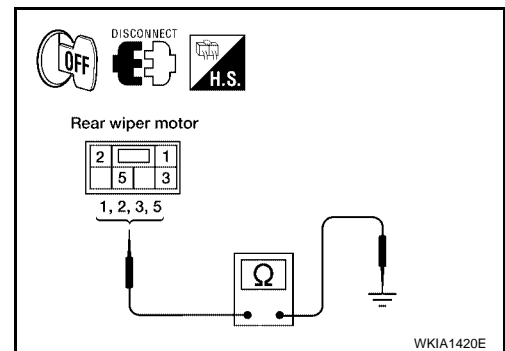

OK or NG

- OK >> GO TO 4.
- NG >> Repair harness or connector.

# REAR WIPER AND WASHER SYSTEM

## 4. CHECK REAR WIPER OPERATING

1. Connect BCM connectors and rear wiper motor connector.
2. Turn ignition switch ON.
3. Turn rear wiper switch ON, then to OFF when wiper arm reaches mid sweep.
4. Check voltage between rear wiper motor connector D704 terminal 6 and ground.

**Battery voltage should exist on the reverse wipe until arm is seated in the stop.**

OK or NG

- OK >> Replace rear wiper motor. Refer to [WW-43, "REMOVAL AND INSTALLATION"](#).
- NG >> Replace BCM. Refer to [BCS-26, "Removal and Installation"](#).

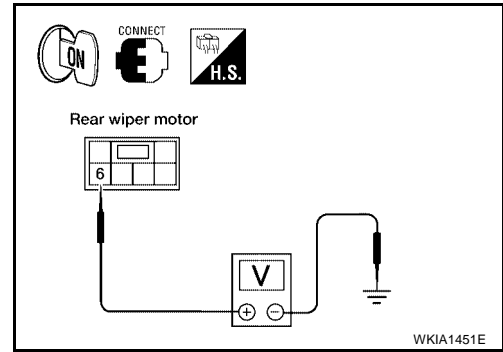

WKIA1451E

### Only Rear Wiper Does Not Operate

EKS00J2N

#### 1. CHECK COMBINATION SWITCH INPUT SIGNAL

Select "BCM" on CONSULT-II. With "WIPER" data monitor, make sure "RR WIPER ON" turns ON-OFF according to operation of wiper switch.

**When rear wiper switch is in ON position : RR WIPER ON**

OK or NG

- OK >> Replace BCM. Refer to [BCS-26, "Removal and Installation"](#).
- NG >> Check the wiper switch. Refer to [BCS-3, "COMBINATION SWITCH READING FUNCTION"](#).

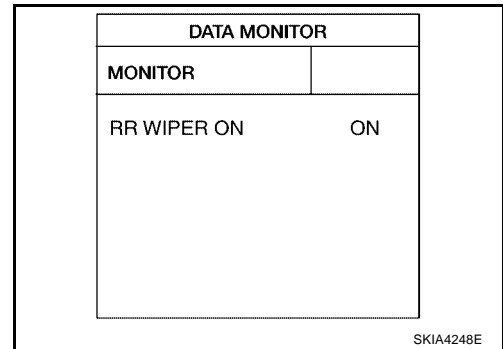

SKIA4248E

### Only Rear Wiper Intermittent Does Not Operate

EKS00J2O

#### 1. CHECK COMBINATION SWITCH INPUT SIGNAL

Select "BCM" on CONSULT-II. With "WIPER" data monitor, make sure "RR WIPER INT" turns ON-OFF according to operation of wiper switch.

**When rear wiper switch is in INT position : RR WIPER INT ON**

OK or NG

- OK >> Replace BCM. Refer to [BCS-26, "Removal and Installation"](#).
- NG >> Check the wiper switch. Refer to [BCS-3, "COMBINATION SWITCH READING FUNCTION"](#).

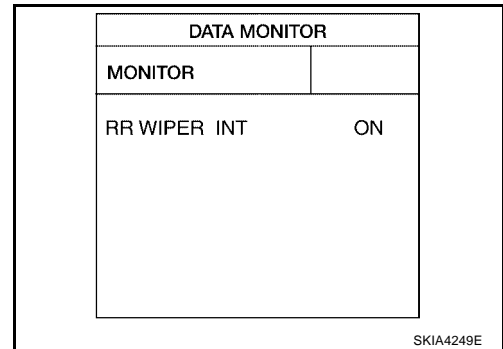

SKIA4249E



# REAR WIPER AND WASHER SYSTEM

## Wiper Does Not Wipe When Rear Washer Operates

EKS00J2P

### 1. CHECK COMBINATION SWITCH INPUT SIGNAL

Select "BCM" on CONSULT-II. With "WIPER" data monitor, make sure "RR WASHER SW" turns ON-OFF according to operation of rear washer switch.

**When rear wiper switch is in WASHER position : RR WASHER SW ON**

OK or NG

- OK >> Replace BCM. Refer to [BCS-26, "Removal and Installation"](#).
- NG >> Check the wiper switch. Refer to [BCS-3, "COMBINATION SWITCH READING FUNCTION"](#).

DATA MONITOR	
MONITOR	
RR WASHER SW	ON

SKIA4250E

A  
B  
C  
D  
E  
F  
G  
H  
I  
J  
L  
M

WW

# REAR WIPER AND WASHER SYSTEM

EKS00J2Q

## Rear Wiper Arm REMOVAL AND INSTALLATION

### Removal

1. Remove wiper arm cover, and remove rear wiper arm nut.
2. Remove the wiper arm.
3. Remove wiper blade.

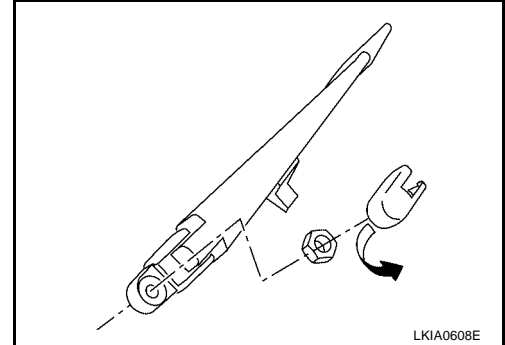

### Installation

1. Operate rear wiper motor one full cycle, then turn "OFF" (Auto Stop).
2. Clean up the pivot area as illustrated. This will reduce the possibility of wiper arm looseness.

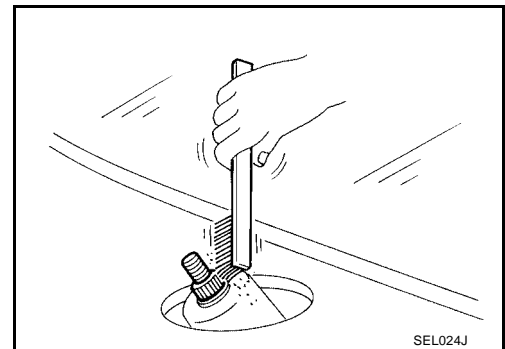

3. Install wiper blade.
4. Install wiper arm so that the arm rests in the stopper and tighten rear wiper arm nut.
5. Install wiper arm cover.

# REAR WIPER AND WASHER SYSTEM

EKS00J2R

## Rear Wiper Motor REMOVAL AND INSTALLATION

SEC. 284

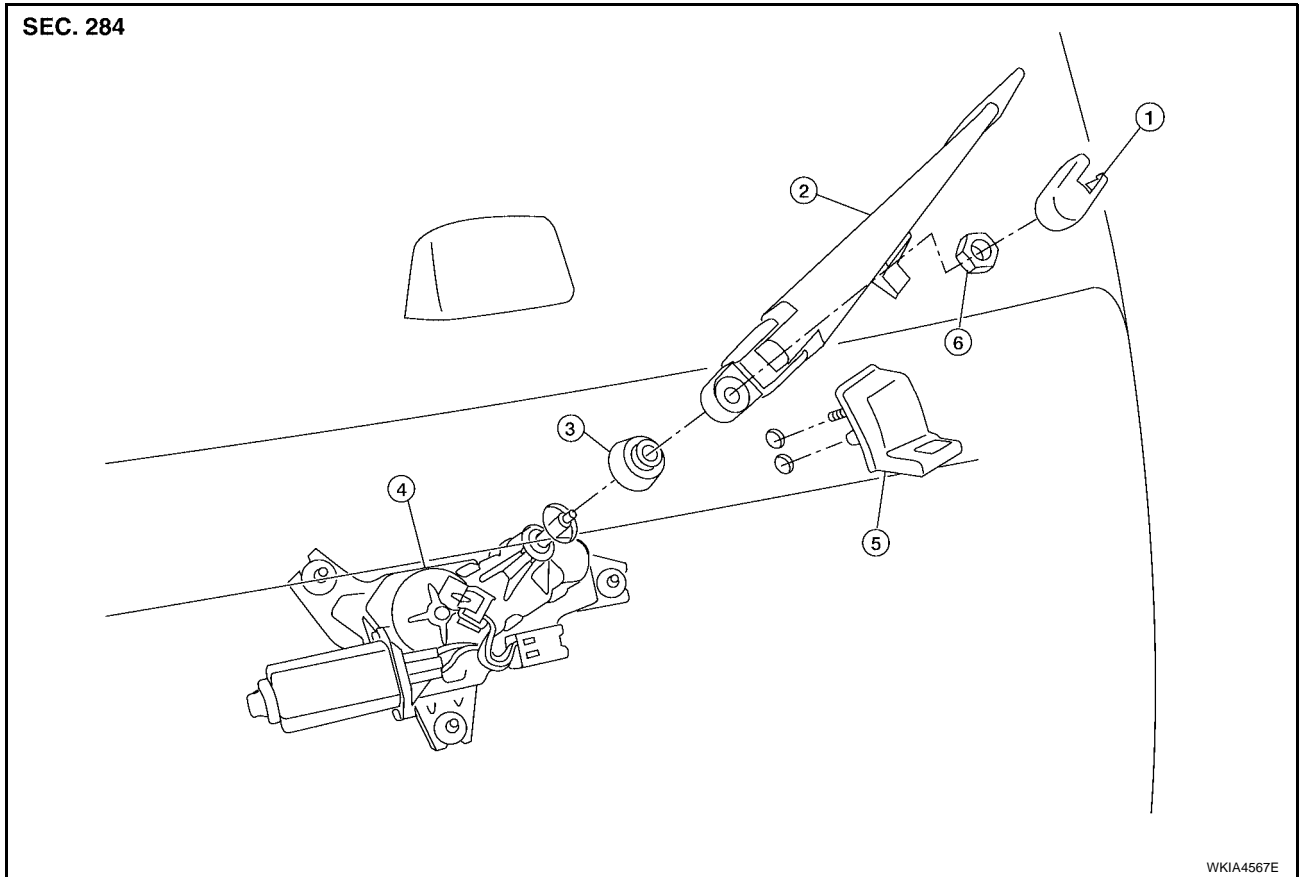

WKIA4567E

- |                     |                        |                       |
|---------------------|------------------------|-----------------------|
| 1. Wiper arm cover  | 2. Wiper arm and blade | 3. Pivot cap          |
| 4. Rear wiper motor | 5. Wiper arm stop      | 6. Rear wiper arm nut |

### REMOVAL

1. Remove wiper arm. Refer to [WW-42, "REMOVAL AND INSTALLATION"](#).
2. Remove pivot cap.
3. Remove back door lock assembly. Refer to [BL-124, "Door Lock Assembly"](#).
4. Disconnect rear wiper motor connector.
5. Remove rear wiper motor bolts, and remove rear wiper motor.

### INSTALLATION

1. Install rear wiper motor to the vehicle.  
**CAUTION:**
  - Do not drop the wiper motor or cause it to contact other parts.
2. Connect rear wiper motor connector.
3. Install back door lock assembly. Refer to [BL-124, "Door Lock Assembly"](#).
4. Attach pivot cap.
5. Install wiper arm. Refer to [WW-42, "REMOVAL AND INSTALLATION"](#).

### Rear Washer Nozzle Adjustment

EKS00J2S

- This vehicle is equipped with a non-adjustable rear washer nozzle.
- If not satisfied with washer fluid spray coverage, confirm that the washer nozzle is installed correctly.
- If the washer nozzle is installed correctly, and the washer fluid spray coverage is not satisfactory, replace the washer nozzle.

A  
B  
C  
D  
E  
F  
G  
H  
I  
J

WW

L  
M

# REAR WIPER AND WASHER SYSTEM

## Rear Washer Tube Layout

EKS00J2T

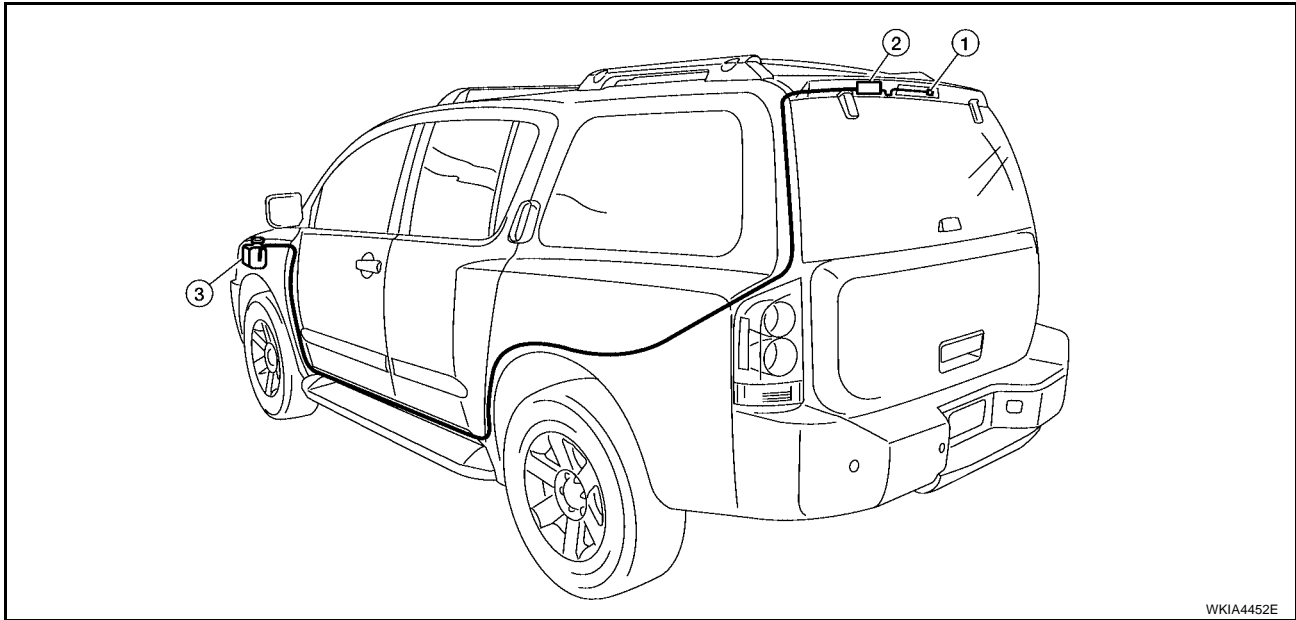

WKIA4452E

1. Rear washer nozzle

2. Check valve

3. Washer fluid reservoir

### NOTE:

Connect the check valve (2) to the washer fluid reservoir tube (1) so that the directional arrow on the check valve (2) points towards the washer nozzle tube (3).

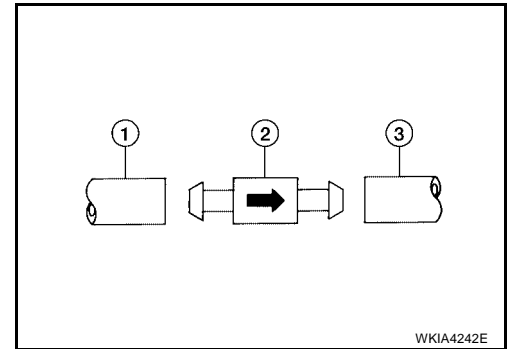

WKIA4242E

## Rear Washer Nozzle REMOVAL AND INSTALLATION

EKS00J2U

### Removal

1. Remove the rear spoiler. Refer to [EI-23, "REAR SPOILER"](#).
2. Release retaining clips, and remove washer nozzle.

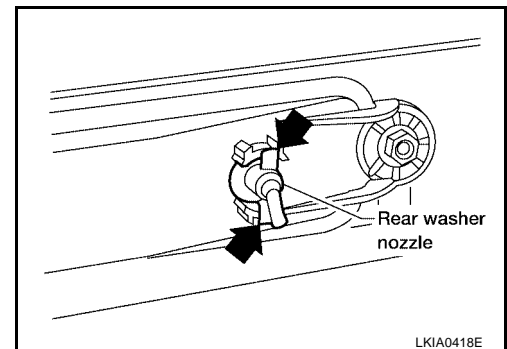

LKIA0418E

### Installation

Installation is in the reverse order of removal.

## Rear Wiper and Washer Switch REMOVAL AND INSTALLATION

EKS00J2V

Refer to [WW-27, "Wiper and Washer Switch"](#).

# REAR WIPER AND WASHER SYSTEM

---

## Washer Fluid Reservoir REMOVAL AND INSTALLATION

EKS00KYD

Refer to [WW-27, "Washer Fluid Reservoir"](#) .

A

## Washer Motor REMOVAL AND INSTALLATION

EKS00KYE

Refer to [WW-28, "Washer Motor"](#) .

B

C

D

E

F

G

H

I

J

WW

L

M

# POWER SOCKET

PF:253A2

## POWER SOCKET

### Wiring Diagram — P/SCKT —

EKS00J2W

### WW-P/SCKT-01

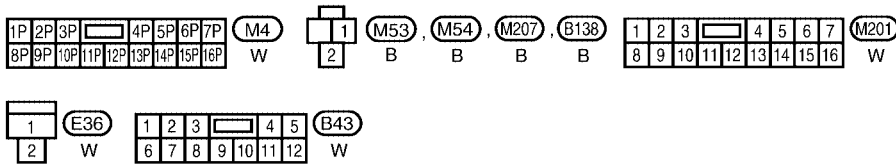
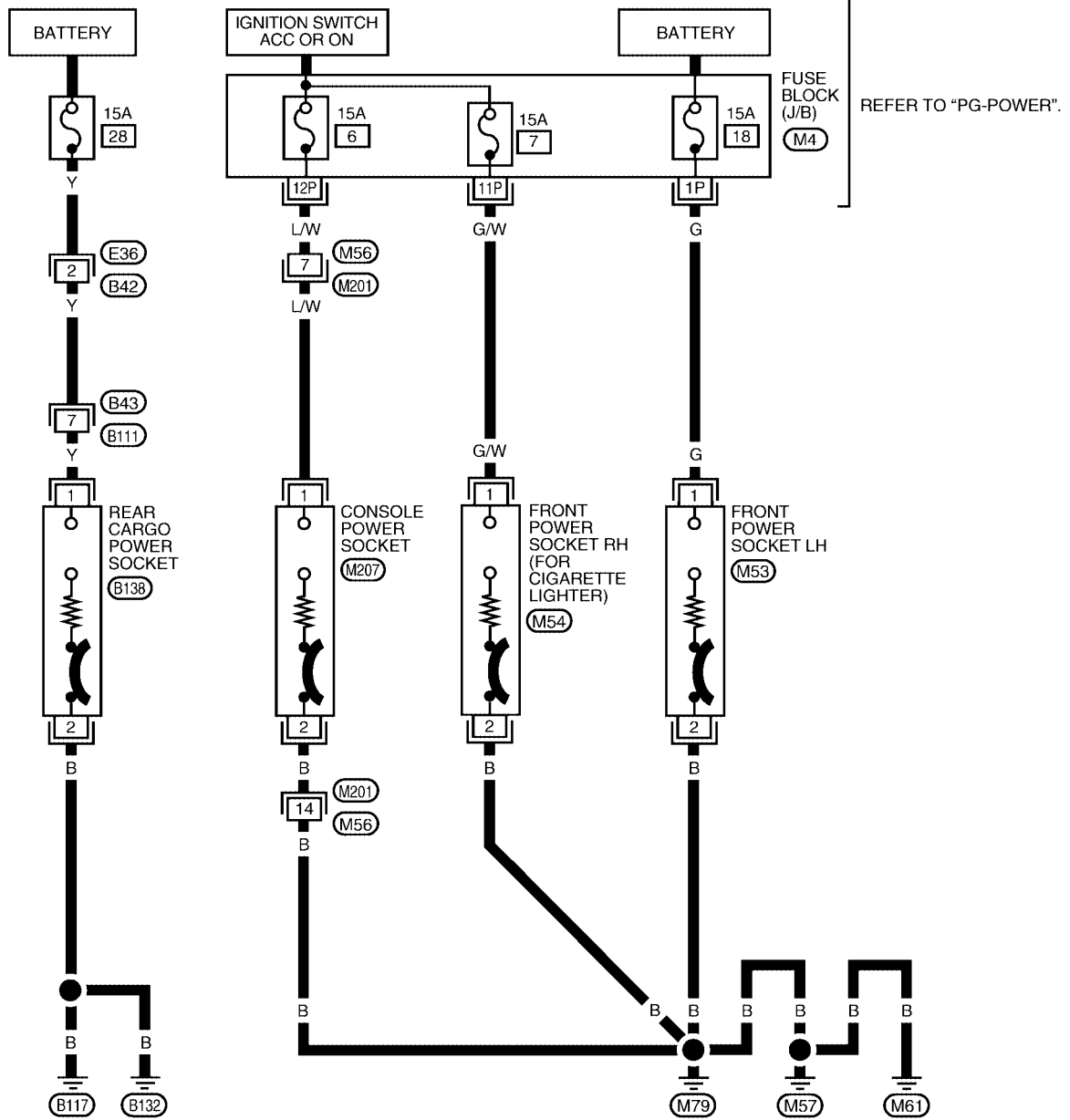

WKWA3525E

# POWER SOCKET

## Power Socket LH and Rear Cargo Power Socket REMOVAL AND INSTALLATION

EKS00J2X

### Removal

1. Disconnect battery negative terminal.
2. Remove inner socket from the ring, while pressing the hook on the ring out from square hole.
3. Disconnect power socket connector.
4. Remove ring from power socket finisher while pressing pawls.

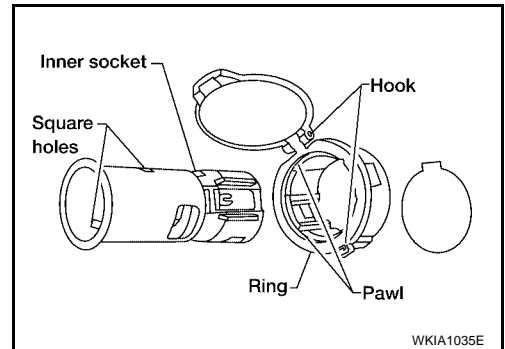

### Installation

Installation is in the reverse order of removal.

## Front Power Socket RH and Console Power Socket REMOVAL AND INSTALLATION

EKS00J2Y

### Removal

1. Remove inner socket from the ring, while pressing the hook on the ring out from square hole.
2. Disconnect power socket connector.
3. Remove ring from power socket finisher while pressing pawls.

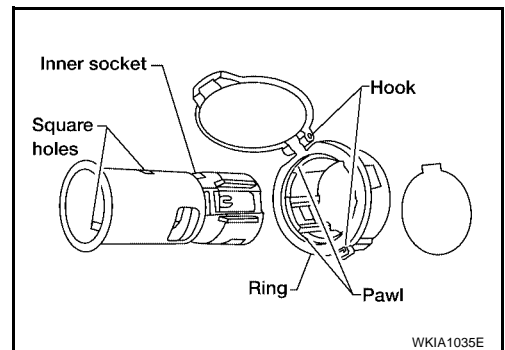

### Installation

Installation is in the reverse order of removal.

A

B

C

D

E

F

G

H

I

J

WW

L

M

# HORN

PF2:25610

## HORN

### Wiring Diagram — HORN —

EKS00JZZ

## WW-HORN-01

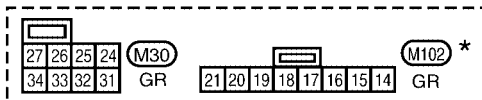
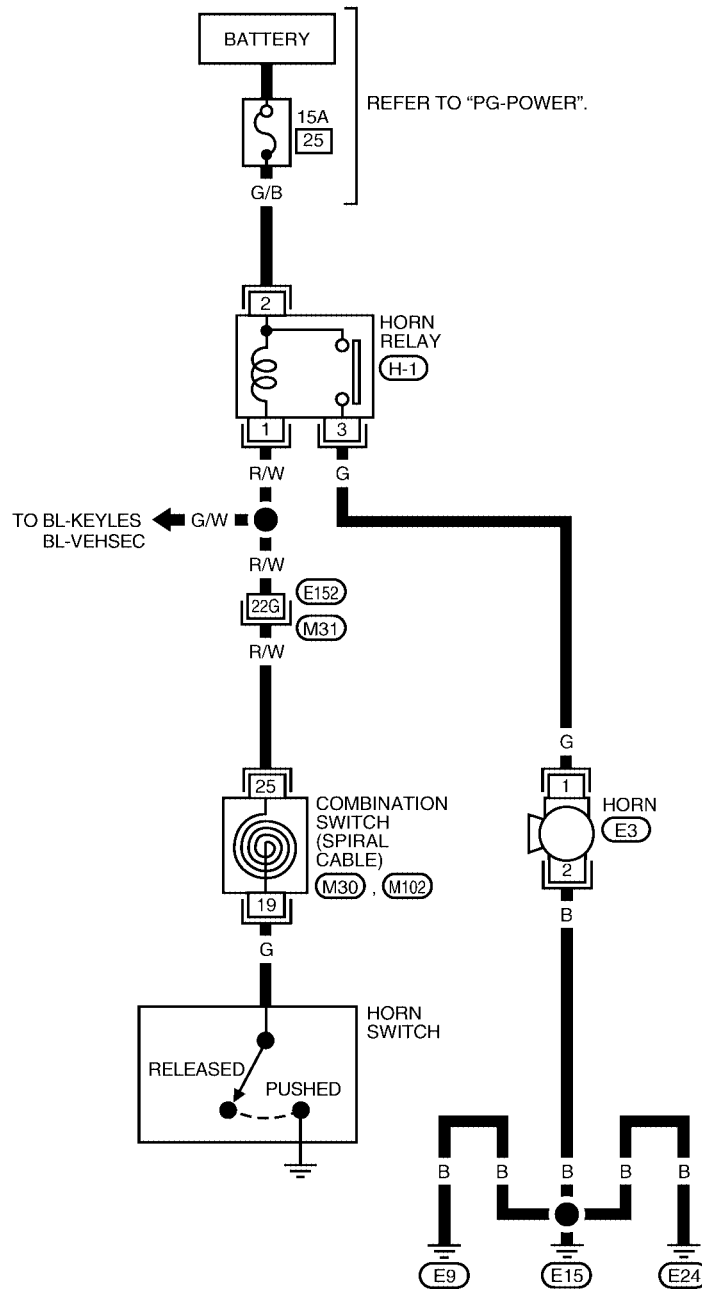

REFER TO THE FOLLOWING.

(M31) - SUPER MULTIPLE JUNCTION (SMJ)

\* : THIS CONNECTOR IS NOT SHOWN IN "HARNES LAYOUT" OF PG SECTION.

WKWA3526E



# HORN

EKS00J30

## Horn

### REMOVAL AND INSTALLATION

#### Removal

1. Remove the front grille. Refer to [EI-17, "FRONT GRILLE"](#) .
2. Disconnect horn connector.
3. Remove horn bolt and remove horn from vehicle.

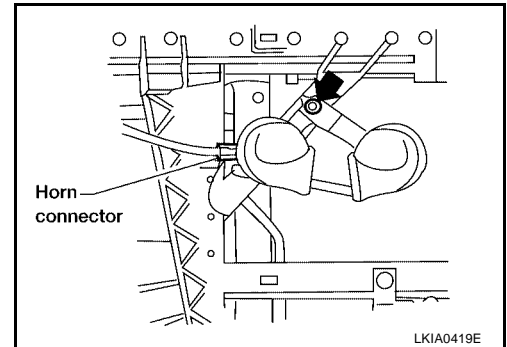

#### Installation

1. Tighten horn bolt to specified torque.
2. Reconnect horn connector.
3. Install front grille. Refer to [EI-17, "FRONT GRILLE"](#) .

A

B

C

D

E

F

G

H

I

J

WW

L

M

# HORN

---