

SECTION **BR**
BRAKE SYSTEM

A
B
C
D
E

CONTENTS

PRECAUTION	3	Inspection	11	BR
PRECAUTIONS	3	BRAKE MASTER CYLINDER	12	
Precaution for Supplemental Restraint System (SRS) "AIR BAG" and "SEAT BELT PRE-TENSIONER"	3	On Board Inspection	12	G
Precaution Necessary for Steering Wheel Rotation After Battery Disconnect	3	BRAKE TUBE AND HOSE	13	
Precaution for Brake System	4	Hydraulic Circuit	13	H
PREPARATION	5	FRONT BRAKE	13	
PREPARATION	5	FRONT BRAKE : Inspection	13	I
Special Service Tool	5	REAR BRAKE	14	
Commercial Service Tool	5	REAR BRAKE : Inspection	14	J
FUNCTION DIAGNOSIS	6	ON-VEHICLE MAINTENANCE	15	
NOISE, VIBRATION AND HARSHNESS (NVH) TROUBLESHOOTING	6	BRAKE PEDAL	15	K
NVH Troubleshooting Chart	6	Inspection and Adjustment	15	
BASIC INSPECTION	7	BRAKE FLUID	17	L
FRONT DISC BRAKE	7	On Board Inspection	17	
BRAKE PAD	7	Drain and Refill	17	
BRAKE PAD : Inspection	7	Bleeding Brake System	17	
DISC ROTOR	7	ON-VEHICLE REPAIR	19	M
DISC ROTOR : Inspection	7	BRAKE PEDAL	19	
REAR DISC BRAKE	9	Removal and Installation	19	N
BRAKE PAD	9	BRAKE TUBE AND HOSE	21	
BRAKE PAD : Inspection	9	Hydraulic Circuit	21	
DISC ROTOR	9	Removal and Installation of Front Brake Piping and Brake Hose	21	O
DISC ROTOR : Inspection	9	Removal and Installation of Rear Brake Piping and Brake Hose	22	
BRAKE BOOSTER	10	Inspection After Installation	23	P
Inspection	10	BRAKE MASTER CYLINDER	25	
VACUUM LINES	11	Removal and Installation	25	
		BRAKE BOOSTER	26	
		Removal and Installation	26	
		VACUUM LINES	28	

Removal and Installation	28	BRAKE MASTER CYLINDER	37
FRONT DISC BRAKE	29	Disassembly and Assembly	37
Exploded View of Brake Pads	29	FRONT DISC BRAKE	39
Removal and Installation of Brake Pads	29	Disassembly and Assembly	39
Brake Burnishing Procedure	30	REAR DISC BRAKE	42
Exploded View of Brake Caliper	31	Disassembly and Assembly	42
Removal and Installation of Brake Caliper and Rotor	31	SERVICE DATA AND SPECIFICATIONS (SDS)	45
REAR DISC BRAKE	34	SERVICE DATA AND SPECIFICATIONS (SDS)	45
Exploded View of Brake Pads	34	General Specification	45
Removal and Installation of Brake Pad	34	Brake Pedal	45
Brake Burnishing Procedure	35	Brake Booster	46
Exploded View of Brake Caliper	35	Check Valve	46
Removal and Installation of Brake Caliper and Disc Rotor	36	Front Disc Brake	46
DISASSEMBLY AND ASSEMBLY	37	Rear Disc Brake	46

PRECAUTIONS

< PRECAUTION >

PRECAUTION

PRECAUTIONS

Precaution for Supplemental Restraint System (SRS) "AIR BAG" and "SEAT BELT PRE-TENSIONER"

INFOID:000000005229936

The Supplemental Restraint System such as "AIR BAG" and "SEAT BELT PRE-TENSIONER", used along with a front seat belt, helps to reduce the risk or severity of injury to the driver and front passenger for certain types of collision. This system includes seat belt switch inputs and dual stage front air bag modules. The SRS system uses the seat belt switches to determine the front air bag deployment, and may only deploy one front air bag, depending on the severity of a collision and whether the front occupants are belted or unbelted. Information necessary to service the system safely is included in the SR and SB section of this Service Manual.

WARNING:

- To avoid rendering the SRS inoperative, which could increase the risk of personal injury or death in the event of a collision which would result in air bag inflation, all maintenance must be performed by an authorized NISSAN/INFINITI dealer.
- Improper maintenance, including incorrect removal and installation of the SRS, can lead to personal injury caused by unintentional activation of the system. For removal of Spiral Cable and Air Bag Module, see the SR section.
- Do not use electrical test equipment on any circuit related to the SRS unless instructed to in this Service Manual. SRS wiring harnesses can be identified by yellow and/or orange harnesses or harness connectors.

PRECAUTIONS WHEN USING POWER TOOLS (AIR OR ELECTRIC) AND HAMMERS

WARNING:

- When working near the Airbag Diagnosis Sensor Unit or other Airbag System sensors with the Ignition ON or engine running, DO NOT use air or electric power tools or strike near the sensor(s) with a hammer. Heavy vibration could activate the sensor(s) and deploy the air bag(s), possibly causing serious injury.
- When using air or electric power tools or hammers, always switch the Ignition OFF, disconnect the battery, and wait at least 3 minutes before performing any service.

Precaution Necessary for Steering Wheel Rotation After Battery Disconnect

INFOID:000000005229937

NOTE:

- This Procedure is applied only to models with Intelligent Key system and NATS (NISSAN ANTI-THEFT SYSTEM).
- Remove and install all control units after disconnecting both battery cables with the ignition knob in the "LOCK" position.
- Always use CONSULT-III to perform self-diagnosis as a part of each function inspection after finishing work. If DTC is detected, perform trouble diagnosis according to self-diagnostic results.

For models equipped with the Intelligent Key system and NATS, an electrically controlled steering lock mechanism is adopted on the key cylinder.

For this reason, if the battery is disconnected or if the battery is discharged, the steering wheel will lock and steering wheel rotation will become impossible.

If steering wheel rotation is required when battery power is interrupted, follow the procedure below before starting the repair operation.

OPERATION PROCEDURE

1. Connect both battery cables.

NOTE:

Supply power using jumper cables if battery is discharged.

2. Use the Intelligent Key or mechanical key to turn the ignition switch to the "ACC" position. At this time, the steering lock will be released.
3. Disconnect both battery cables. The steering lock will remain released and the steering wheel can be rotated.
4. Perform the necessary repair operation.

A
B
C
D
E
BR
G
H
I
J
K
L
M
N
O
P

PRECAUTIONS

< PRECAUTION >

5. When the repair work is completed, return the ignition switch to the "LOCK" position before connecting the battery cables. (At this time, the steering lock mechanism will engage.)
6. Perform a self-diagnosis check of all control units using CONSULT-III.

Precaution for Brake System

INFOID:000000004918349

- Always use recommended brake fluid. Refer to [MA-19. "FOR NORTH AMERICA : Fluids and Lubricants"](#).
- Do not reuse drained brake fluid.
- Be careful not to splash brake fluid on painted areas.
- To clean or wash all parts of master cylinder, disc brake caliper and wheel cylinder, use clean brake fluid.
- Do not use mineral oils such as gasoline or kerosene. They will ruin rubber parts of the hydraulic system.
- Use flare nut wrench when removing and installing brake tube.
- Always check tightening torque when installing brake lines.
- Before working, turn ignition switch to OFF and disconnect connectors for ABS actuator and electric unit (control unit) or battery terminals.
- Burnish the brake contact surfaces after refinishing or replacing drums or rotors, after replacing pads or linings, or if a soft pedal occurs at very low mileage. Refer to [BR-30. "Brake Burnishing Procedure"](#).

WARNING:

- **Clean brake pads and shoes with a waste cloth, then wipe with a dust collector.**

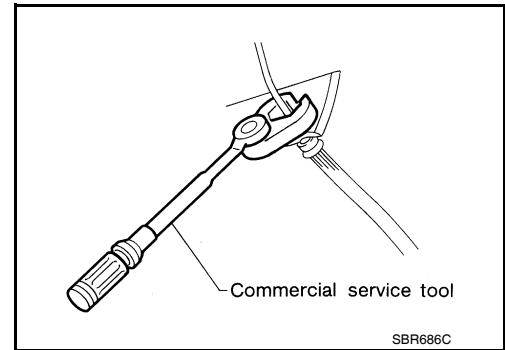

PREPARATION

< PREPARATION >

PREPARATION

PREPARATION

Special Service Tool

INFOID:000000004918350

The actual shapes of Kent-Moore tools may differ from those of special service tools illustrated here.

Tool number (Kent-Moore No.) Tool name	Description
— (J-46532) Brake and clutch pedal height measurement tool	Measuring brake pedal height
38-PFM90.5 (—) Pro-Cut PFM90 On-Car Brake Lathe	Turning rotors

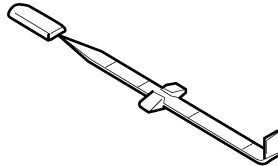

LFIA0227E

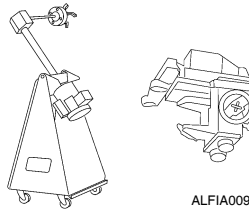

ALFIA0092ZZ

Commercial Service Tool

INFOID:000000004918351

Tool name	Description
1. Flare nut crowfoot 2. Torque wrench	Removing and installing each brake piping. a: 10 mm (0.39 in) / 12 mm (0.47 in)
Power tool	Removing nuts, bolts and screws.

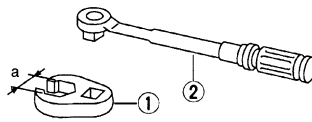

S-NT360



PIIB1407E

FRONT DISC BRAKE

< BASIC INSPECTION >

BASIC INSPECTION

FRONT DISC BRAKE

BRAKE PAD

BRAKE PAD : Inspection

INFOID:000000004918353

PAD WEAR

Check pad thickness from an inspection hole on cylinder body.
Check using a scale if necessary.

Standard thickness : Refer to [BR-46. "Front Disc Brake"](#).

Repair limit thickness : Refer to [BR-46. "Front Disc Brake"](#).

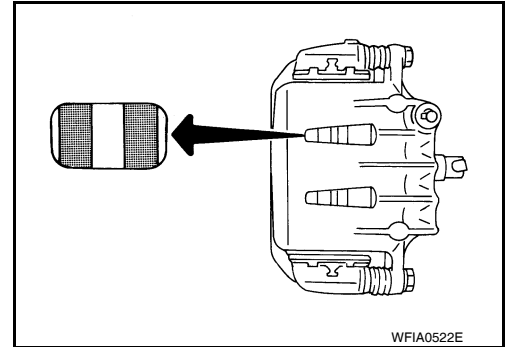

DISC ROTOR

DISC ROTOR : Inspection

INFOID:000000004918354

VISUAL

Check surface of disc rotor for uneven wear, cracks, and serious damage. Replace as necessary.

RUNOUT

1. Attach disc rotor to wheel hub using wheel nuts at two or more positions.
2. Inspect runout using a dial gauge placed at 10 mm (0.39 in) inside the disc edge.

Runout limit : Refer to [BR-46. "Front Disc Brake"](#).

(with it attached to the vehicle)

NOTE:

Before measuring, make sure that wheel bearing axial end play is within the specification. Refer to [FAX-6. "On-Vehicle Inspection and Service"](#).

3. When runout exceeds limit value, displace mounting positions of disc rotor by one hole. And then find a position of the minimum value for runout.
4. If runout is outside the specified value after performing the above operation, turn disc rotor using Tool.

Tool number : 38-PFM90.5 (—)

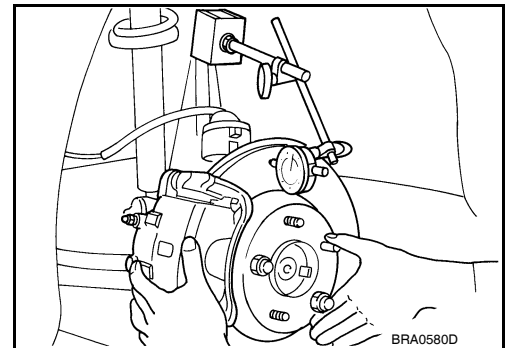

THICKNESS

FRONT DISC BRAKE

< BASIC INSPECTION >

Check thickness of the disc rotor using a micrometer. Replace disc rotor if thickness is less than the wear limit.

Standard thickness

: Refer to [BR-46, "Front Disc Brake"](#).

Repair limit thickness

: Refer to [BR-46, "Front Disc Brake"](#).

**Thickness variation
(Measured at 8 positions)**

: Refer to [BR-46, "Front Disc Brake"](#).

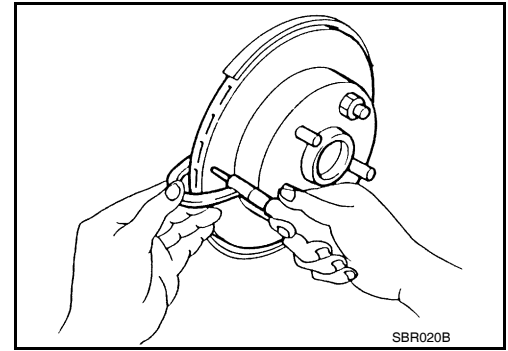

REAR DISC BRAKE

< BASIC INSPECTION >

REAR DISC BRAKE

BRAKE PAD

BRAKE PAD : Inspection

INFOID:000000004918355

PAD WEAR

Check pad thickness from an inspection hole on cylinder body.
Check using a scale if necessary.

Standard thickness : Refer to [BR-46, "Rear Disc Brake"](#).

Repair limit thickness : Refer to [BR-46, "Rear Disc Brake"](#).

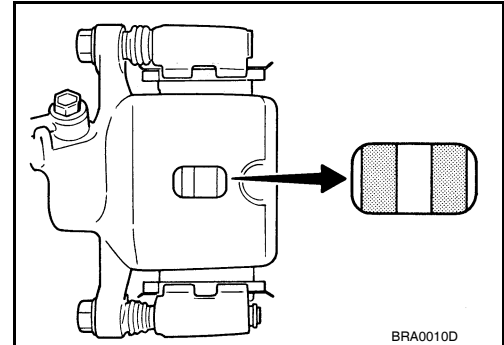

BRA0010D

DISC ROTOR

DISC ROTOR : Inspection

INFOID:000000004918356

VISUAL

Check surface of disc rotor for uneven wear, cracks, and serious damage. Replace as necessary.

RUNOUT

1. Attach disc rotor to wheel hub using wheel nuts at two or more positions.
2. Inspect runout using dial gauge placed at 10 mm (0.39 in) inside disc edge.

Runout limit : Refer to [BR-46, "Rear Disc Brake"](#).
(With it attached to the vehicle)

NOTE:

Before measuring, make sure that wheel bearing axial end play is within the specification. Refer to [RAX-6, "On-Vehicle Inspection and Service"](#).

3. When runout exceeds limit value, displace mounting positions of disc rotor by one hole. And then find a position of the minimum value for runout.
4. If runout is outside the specified value after performing the above operation, turn disc rotor using Tool.

Tool number : 38-PFM90.5 (—)

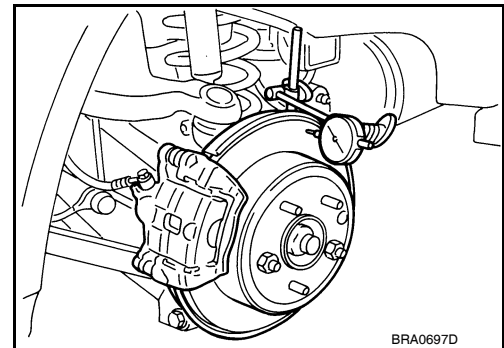

BRA0697D

THICKNESS

Check the thickness of the disc rotor using a micrometer. Replace disc rotor if the thickness is less than the wear limit.

Standard thickness : Refer to [BR-46, "Rear Disc Brake"](#).

Repair limit thickness : Refer to [BR-46, "Rear Disc Brake"](#).

Thickness variation (Measured at 8 positions) : Refer to [BR-46, "Rear Disc Brake"](#).

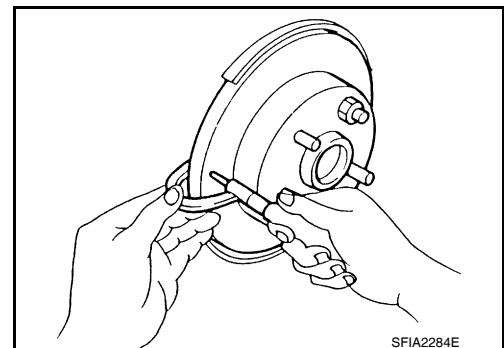

SFIA2284E

BRAKE BOOSTER

< BASIC INSPECTION >

BRAKE BOOSTER

Inspection

INFOID:000000004918357

OPERATION

With engine stopped, change vacuum to atmospheric pressure by depressing brake pedal several times. Then with brake pedal fully depressed, start engine and when vacuum pressure reaches the standard, make sure that clearance between brake pedal and floor panel decreases.

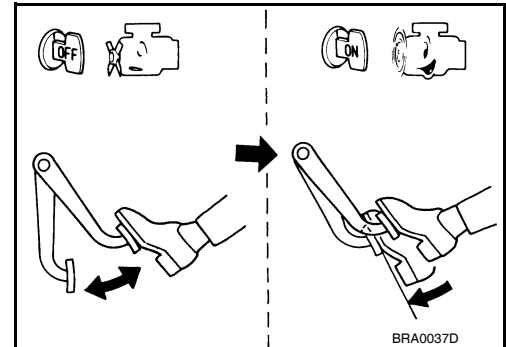

AIR TIGHT

- Run engine at idle for approximately 1 minute, and stop it after applying vacuum to booster. Depress brake pedal normally to change vacuum to atmospheric pressure. Make sure that distance at intervals of 5 seconds between brake pedal and floor panel gradually increases.

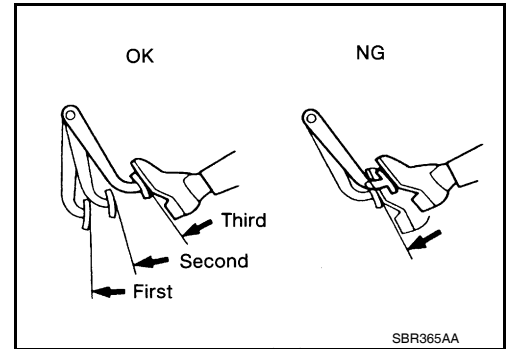

- Depress brake pedal while engine is running, and stop engine with pedal depressed. The pedal stroke should not change after holding pedal down for 30 seconds.

VACUUM LINES

< BASIC INSPECTION >

VACUUM LINES

Inspection

INFOID:000000004918358

VISUAL INSPECTION

Check for improper assembly, damage and deterioration. Replace as necessary.

CHECK VALVE INSPECTION

Airtightness Inspection

Use a suitable vacuum pump to check. Connect to brake booster side of check valve.

Check valve specification : Refer to [BR-46, "Check Valve"](#).

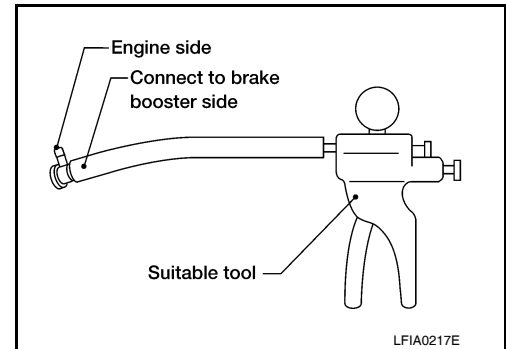

A
B
C
D
E
BR
G
H
I
J
K
L
M
N
O
P

BRAKE MASTER CYLINDER

< BASIC INSPECTION >

BRAKE MASTER CYLINDER

On Board Inspection

INFOID:000000004918359

LEAK INSPECTION

Check for leaks at master cylinder to brake booster attachment point, reservoir tank, and brake tube connections.

BRAKE TUBE AND HOSE

< BASIC INSPECTION >

BRAKE TUBE AND HOSE

Hydraulic Circuit

INFOID:000000004918360

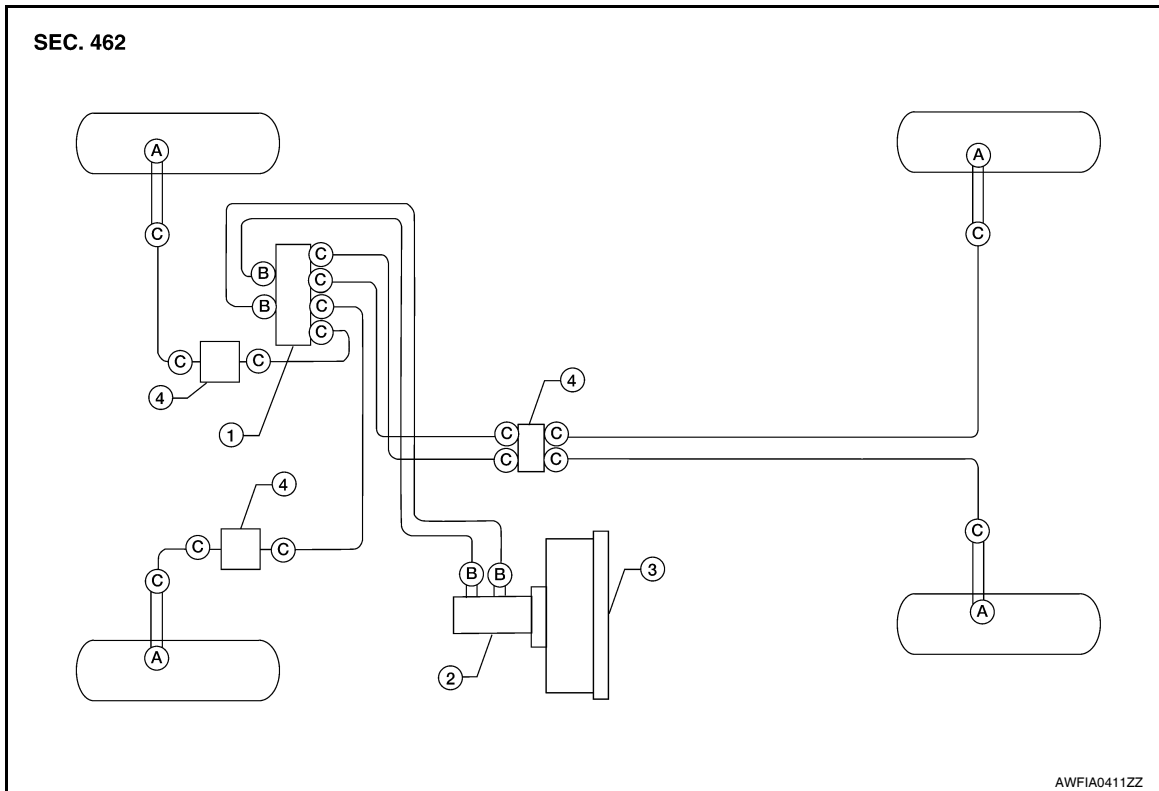

- | | | |
|---|--|---|
| 1. Actuator | 2. Master cylinder | 3. Brake booster |
| 4. Connector | A. Union bolt
18.2 N·m (1.9 kg-m, 13 ft-lb) | B. Flare nut M12
18.2 N·m (1.9 kg-m, 13 ft-lb) |
| C. Flare nut M10
16.2 N·m (1.7 kg-m, 12 ft-lb) | | |

CAUTION:

- All hoses and piping (tubes) must be free from excessive bending, twisting and pulling.
- Make sure there is no interference with other parts when turning the steering wheel both clockwise and counterclockwise.
- The brake piping is an important safety part. If a brake fluid leak is detected, always disassemble the parts. Replace applicable part with a new one, if necessary.
- Be careful not to splash brake fluid on painted areas; it may cause paint damage. If brake fluid is splashed on painted areas, wash it away with water immediately.
- Do not bend or twist brake hose sharply, or strongly pull it.
- When removing components, cover connections so that no dirt, dust, or other foreign matter gets in.
- Refill with new specified brake fluid. Refer to [MA-19, "FOR NORTH AMERICA : Fluids and Lubricants"](#).
- Do not reuse drained brake fluid.

FRONT BRAKE

FRONT BRAKE : Inspection

INFOID:000000004918361

INSPECTION AFTER REMOVAL

CAUTION:

Brake tubes and hoses are important safety parts. Always disassemble the parts and retighten their fittings, if a brake fluid leak is detected. Replace applicable part with a new one, if damaged part is detected.

BRAKE TUBE AND HOSE

< BASIC INSPECTION >

1. Check brake lines (tubes and hoses) and connections for fluid leaks, damage, twists, deformation, contacts with other parts, and loose connections. Replace any parts as necessary. Refer to [BR-21, "Removal and Installation of Front Brake Piping and Brake Hose"](#).
2. While depressing brake pedal under a force of 785 N (80 kg-f, 177 lb-f) with engine running for approximately 5 seconds, check each part for fluid leaks.

REAR BRAKE

REAR BRAKE : Inspection

INFOID:000000004918362

INSPECTION AFTER REMOVAL

CAUTION:

Brake tubes and hoses are important safety parts. Always disassemble the parts and retighten their fittings, if a brake fluid leak is detected. Replace applicable part with a new one, if damaged part is detected.

1. Check brake lines (tubes and hoses) and connections for fluid leaks, damage, twists, deformation, contacts with other parts, and loose connections. Replace any parts as necessary. Refer to [BR-22, "Removal and Installation of Rear Brake Piping and Brake Hose"](#).
2. While depressing brake pedal under a force of 785 N (80 kg-f, 177 lb-f) with engine running for approximately 5 seconds, check each part for fluid leaks.

BRAKE PEDAL

< ON-VEHICLE MAINTENANCE >

ON-VEHICLE MAINTENANCE

BRAKE PEDAL

Inspection and Adjustment

INFOID:000000004918363

INSPECTION

1. Inspect the brake pedal free height (H) from the floor using Tool at a 90° angle to the floor as shown.

Tool number : — (J-46532)

2. Adjust the brake pedal height to specifications.

CAUTION:

When equipped with adjustable pedal, the pedal must be in the forward most (closest to the floor) position for pedal height measurement.

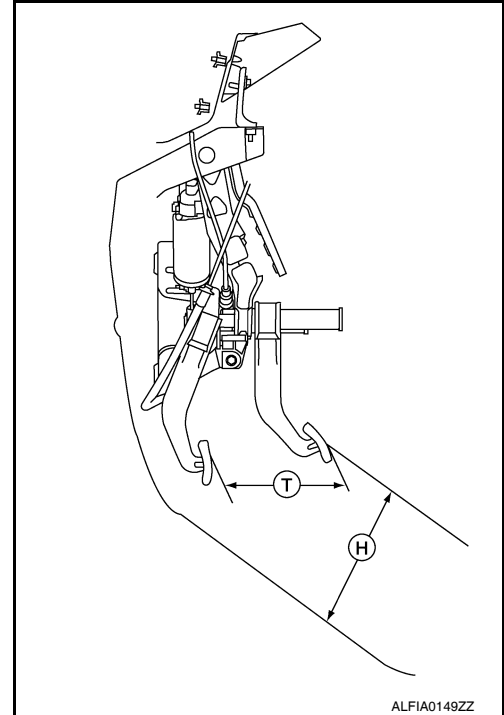

Brake Pedal Specifications

Unit: mm (in)

Pedal free height (H) with pedal in forward most position	Refer to BR-45. "Brake Pedal" .
Pedal travel (T)	Refer to BR-45. "Brake Pedal" .
Clearance between brake pedal bracket and threaded end of stop lamp switch and ASCD cancel switch	Refer to BR-45. "Brake Pedal" .

ADJUSTMENT

1. Loosen the stop lamp switch and ASCD cancel switch by turning them 45° counterclockwise.

BRAKE PEDAL

< ON-VEHICLE MAINTENANCE >

- Loosen lock nut (A) on the input rod, then turn input rod to adjust the brake pedal to the specified height. When finished adjusting, tighten the lock nut (A) to specification.

Lock nut (A) : 18.7 N·m (1.9 kg-m, 14 ft-lb)

CAUTION:

Make sure that the screw portion of the end of input rod is located inside the clevis.

- With the brake pedal pulled up and held by hand, press the stop lamp switch and the ASCD cancel switch in until the threaded ends contact the brake pedal bracket.
- With the threaded ends of the stop lamp switch and ASCD switch contacting the pedal bracket, turn the switches 45° clockwise to lock in place. Check that the stop lamp switch and ASCD cancel switch threaded end to brake pedal bracket gap (C) is within specifications.

CAUTION:

Make sure that the gap (C) between the brake pedal bracket and stop lamp switch and ASCD cancel switch threaded ends are within specification.

- Check the brake pedal for smooth operation.

CAUTION:

Make sure that the stop lamp goes off when the brake pedal is released.

- Start the engine and check the height of the brake pedal when depressing it.

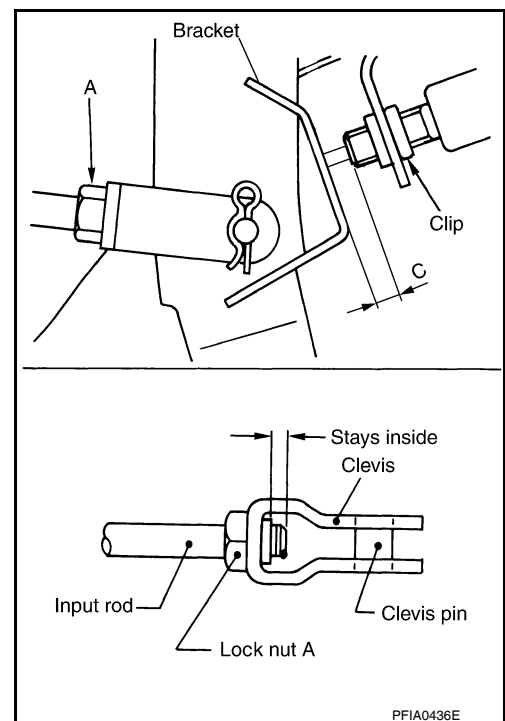

BRAKE FLUID

< ON-VEHICLE MAINTENANCE >

BRAKE FLUID

On Board Inspection

INFOID:000000004918364

LEVEL CHECK

- Make sure the fluid level in reservoir tank is between MAX and MIN lines as shown.
- Visually check around reservoir tank for fluid leaks.
- If fluid level is excessively low, check brake system for leaks.
- If brake warning lamp remains illuminated after parking brake pedal is released, check brake system for fluid leaks.

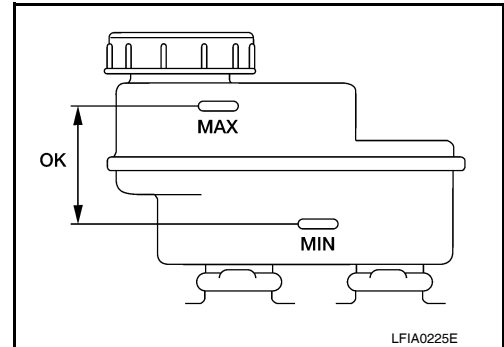

Drain and Refill

INFOID:000000004918365

CAUTION:

- Refill with new brake fluid. Refer to [MA-19, "FOR NORTH AMERICA : Fluids and Lubricants"](#).
- Do not reuse drained brake fluid.
- Do not let brake fluid splash on the painted surfaces of the body. This might damage the paint, so if splashing it, immediately wipe off the area and wash away with water.
- Before servicing, disconnect ABS actuator and electric unit (control unit) connector or battery negative terminal.

1. Connect a vinyl tube to each bleed valve.
2. Depress brake pedal, loosen each bleed valve, and gradually remove brake fluid.

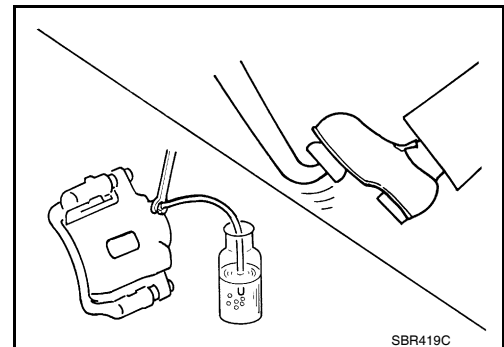

3. Make sure there is no foreign material in reservoir tank, and refill with new brake fluid.
4. Rest foot on brake pedal. Loosen bleed valve. Slowly depress pedal until it stops. Tighten bleed valve. Release brake pedal. Repeat this process a few times, then pause to add new brake fluid to master cylinder. Continue until new brake fluid flows out of the bleed valve.

Bleed the air out of the brake hydraulic system. Refer to [BR-17, "Bleeding Brake System"](#).

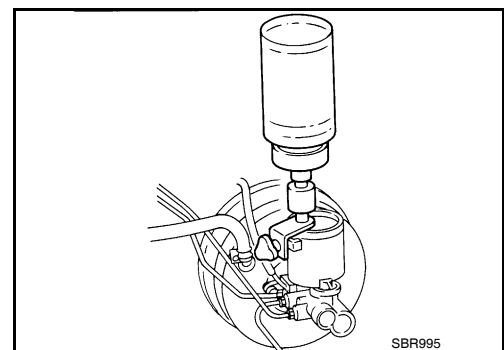

Bleeding Brake System

INFOID:000000004918366

CAUTION:

While bleeding the brake hydraulic system, pay attention to the master cylinder reservoir tank fluid level.

1. Turn ignition switch OFF and disconnect ABS actuator and electric unit (control unit) connector or battery negative terminal.
2. Connect a vinyl tube to the rear right bleed valve.

A
B
C
D
E
BR
G
H
I
J
K
L
M
N
O
P

BRAKE FLUID

< ON-VEHICLE MAINTENANCE >

3. Fully depress brake pedal 4 to 5 times.
4. With brake pedal depressed, loosen bleed valve to let the air out, and then tighten it immediately.
5. Repeat steps 3 and 4 until no more air comes out.
6. Tighten bleed valve to the specified torque. Refer to [BR-31, "Exploded View of Brake Caliper"](#) (front disc brake), [BR-35, "Exploded View of Brake Caliper"](#) (rear disc brake).
7. Repeat steps 2 through 6 at each wheel, with master cylinder reservoir tank filled at least half way, bleeding air in order from the front left, rear left, and front right bleed valves.

BRAKE PEDAL

< ON-VEHICLE REPAIR >

ON-VEHICLE REPAIR

BRAKE PEDAL

Removal and Installation

INFOID:000000004918367

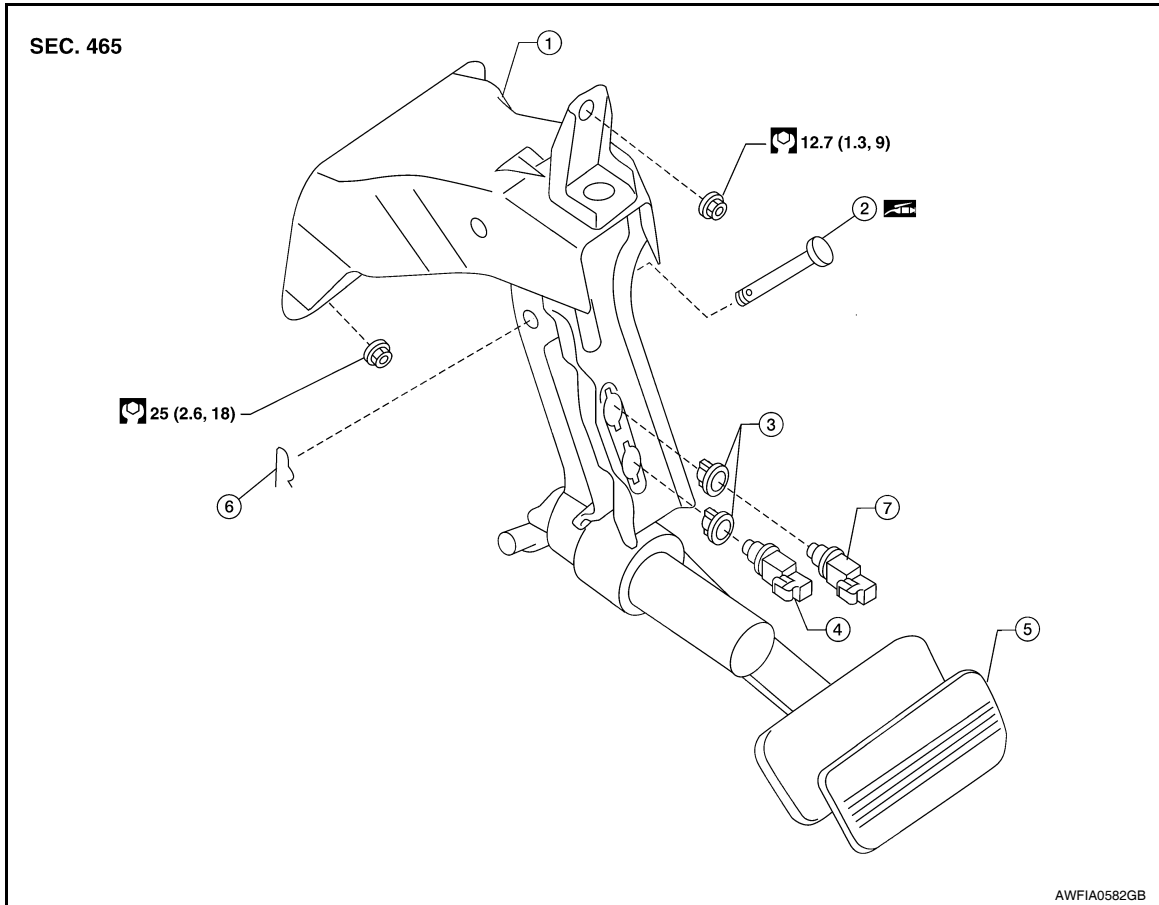

- | | | |
|-------------------------|---------------|-------------|
| 1. Brake pedal assembly | 2. Clevis pin | 3. Clip |
| 4. Stop lamp switch | 5. Pedal pad | 6. Snap pin |
| 7. ASCD cancel switch | | |

REMOVAL

CAUTION:

- Before removal and installation, the accelerator and brake pedals must be in the forward most position (closest to the floor). This is to align the base position of the accelerator and brake pedals.
- Do not disassemble the brake pedal adjusting mechanism.
- Avoid damage from dropping the brake pedal assembly during handling.
- Keep the brake pedal assembly away from water.

1. Remove the lower instrument panel LH. Refer to [IP-11, "Exploded View"](#).
2. Remove the stop lamp switch and ASCD cancel switch from the pedal assembly.

BRAKE PEDAL

< ON-VEHICLE REPAIR >

3. Disconnect the adjustable brake pedal cable from the adjustable pedal electric motor.
 - Unlock (1) then pull (2) the adjustable brake pedal cable to disconnect it from the adjustable pedal electric motor as shown.

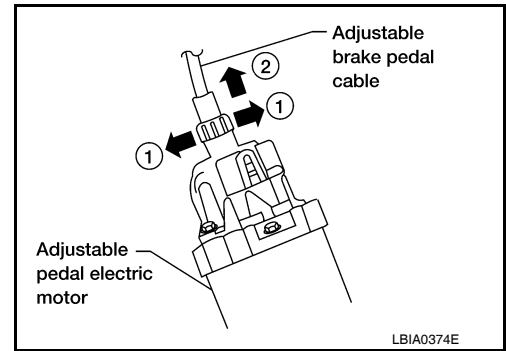

4. Remove snap pin and clevis pin from the clevis of brake booster.
5. Remove brake pedal assembly nuts and remove the brake pedal assembly.
 - Temporarily install the brake pedal assembly nuts by hand to support the brake booster.

WARNING:

Do not bend the brake tubing.

CAUTION:

- **Before removal and installation, the accelerator and brake pedals must be in the forward most position (closest to the floor). This is to align the base position of the accelerator and brake pedals.**
- **Do not disassemble the brake pedal adjusting mechanism.**
- **Avoid damage from dropping the brake pedal assembly during handling.**
- **Keep the brake pedal assembly away from water.**

INSPECTION AFTER REMOVAL

Check the brake pedal assembly for the following items:

- Crack or deformation of clevis pin stopper
- Clevis pin deformation
- Crack of any welded portion of the brake pedal assembly
- Brake pedal bend or deformation

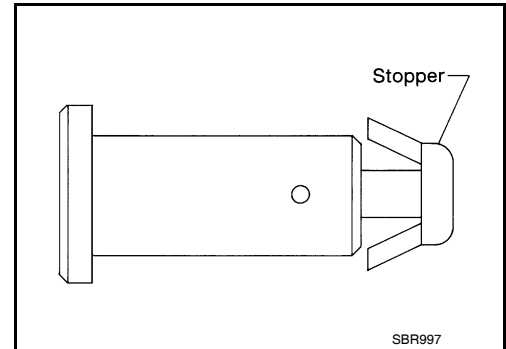

INSTALLATION

Installation is in the reverse order of removal.

- Check the brake pedal for smooth operation. There should be no binding or sticking when applying or releasing the brake pedal.
- Check the brake pedal adjustable feature for smooth operation. There should be no binding or sticking when adjusting the brake pedal forward or backward.
- After installing the brake pedal assembly, be sure to adjust it. Refer to [BR-15. "Inspection and Adjustment"](#).

BRAKE TUBE AND HOSE

< ON-VEHICLE REPAIR >

BRAKE TUBE AND HOSE

Hydraulic Circuit

INFOID:000000004918368

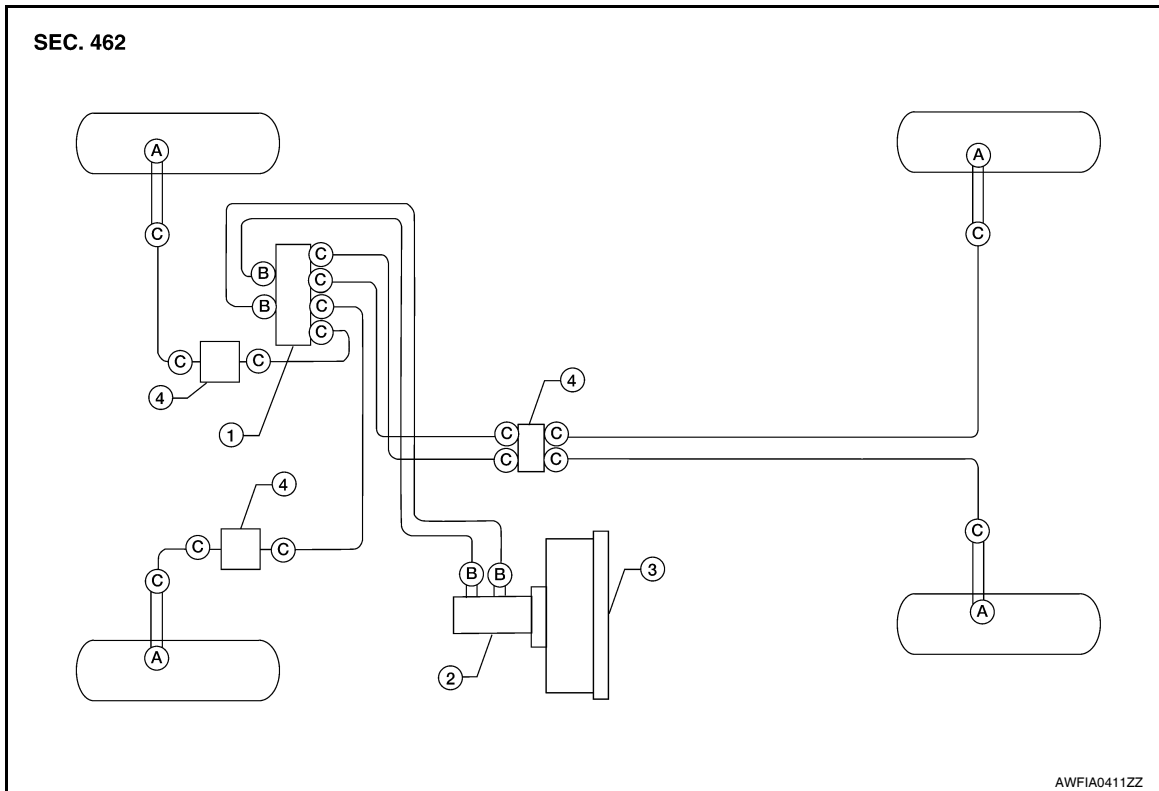

- | | | |
|---|--|---|
| 1. Actuator | 2. Master cylinder | 3. Brake booster |
| 4. Connector | A. Union bolt
18.2 N·m (1.9 kg-m, 13 ft-lb) | B. Flare nut M12
18.2 N·m (1.9 kg-m, 13 ft-lb) |
| C. Flare nut M10
16.2 N·m (1.7 kg-m, 12 ft-lb) | | |

CAUTION:

- All hoses and piping (tubes) must be free from excessive bending, twisting and pulling.
- Make sure there is no interference with other parts when turning the steering wheel both clockwise and counterclockwise.
- The brake piping is an important safety part. If a brake fluid leak is detected, always disassemble the parts. Replace applicable part with a new one, if necessary.
- Be careful not to splash brake fluid on painted areas; it may cause paint damage. If brake fluid is splashed on painted areas, wash it away with water immediately.
- Do not bend or twist brake hose sharply, or strongly pull it.
- When removing components, cover connections so that no dirt, dust, or other foreign matter gets in.
- Refill with new specified brake fluid. Refer to [MA-19, "FOR NORTH AMERICA : Fluids and Lubricants"](#).
- Do not reuse drained brake fluid.

Removal and Installation of Front Brake Piping and Brake Hose

INFOID:000000004918369

REMOVAL

1. Remove front wheel and tire using power tool.
2. Remove brake reservoir cap.

BRAKE TUBE AND HOSE

< ON-VEHICLE REPAIR >

3. Remove brake tube from brake hose, using a suitable tool.
4. Remove lock plate and brake hose from bracket.

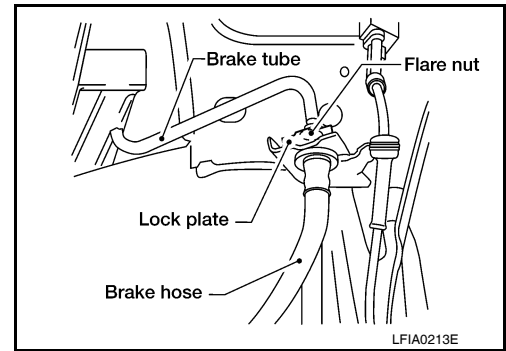

5. Remove union bolt and then remove brake hose from cylinder body.

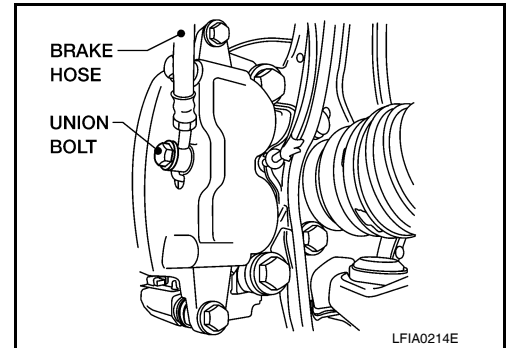

INSTALLATION

1. Install brake hose by aligning with the protrusion on cylinder body, then install the union bolt and new copper washers and tighten to specification. Refer to [BR-13, "Hydraulic Circuit"](#).

CAUTION:

Do not reuse copper washer.

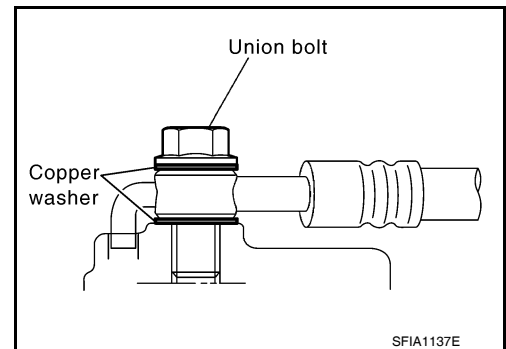

2. Insert brake hose end through bracket, then secure it to bracket with lock plate.
3. Install brake tube to brake hose, then tighten the flare nut using a suitable tool. Refer to [BR-13, "Hydraulic Circuit"](#).

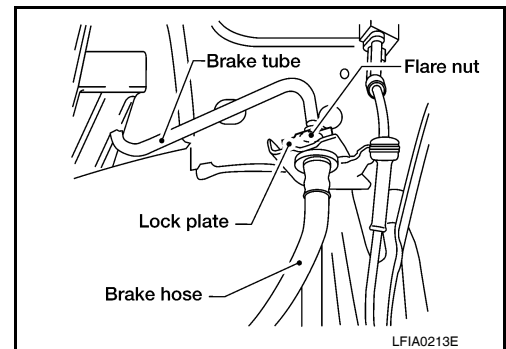

4. Refill brake fluid and bleed air. Refer to [BR-17, "Bleeding Brake System"](#).
5. Install front wheel and tire. Refer to [WT-50, "Rotation"](#).

Removal and Installation of Rear Brake Piping and Brake Hose

INFOID:000000004918370

REMOVAL

1. Remove rear wheel and tire using power tool.
2. Remove brake reservoir cap.

BRAKE TUBE AND HOSE

< ON-VEHICLE REPAIR >

3. Remove brake tube from brake hose, using a suitable tool.
4. Remove lock plate and brake hose from bracket.

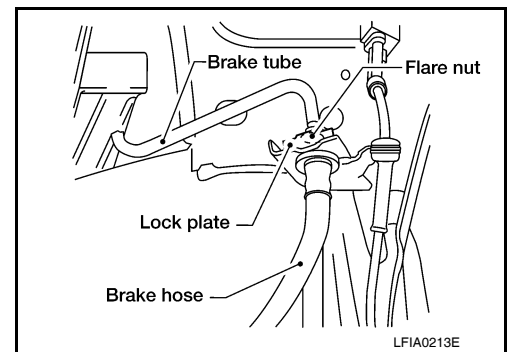

5. Remove union bolt and then remove brake hose from cylinder body.

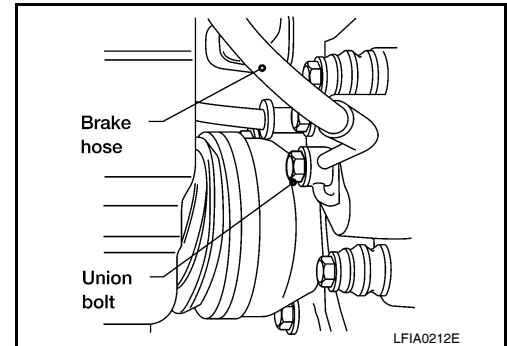

INSTALLATION

1. Install brake hose by aligning with the protrusion on cylinder body, then install the union bolt and new copper washers and tighten to specification. Refer to [BR-13, "Hydraulic Circuit"](#).

CAUTION:

Do not reuse copper washer.

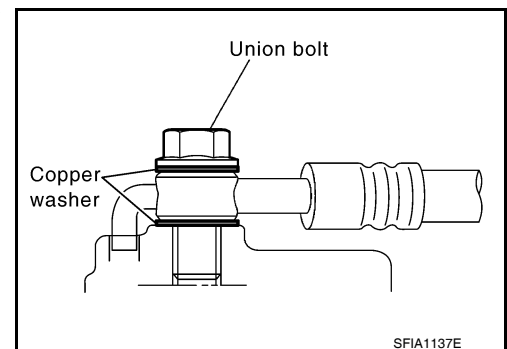

2. Insert brake hose end through bracket, then secure it to bracket with lock plate.
3. Install brake tube to brake hose, then tighten the flare nut using a suitable tool. Refer to [BR-13, "Hydraulic Circuit"](#).

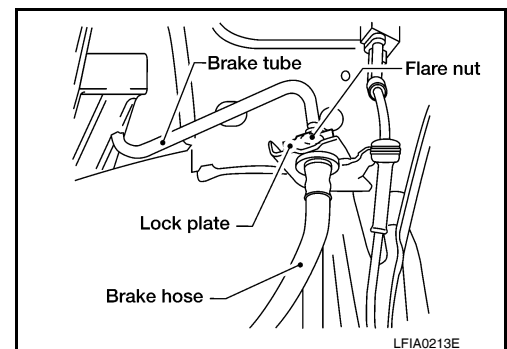

4. Refill brake fluid and bleed air. Refer to [BR-17, "Bleeding Brake System"](#).
5. Install rear wheel and tire. Refer to [WT-50, "Rotation"](#).

Inspection After Installation

INFOID:000000004918371

CAUTION:

Brake tubes and hoses are important safety parts. Always disassemble the parts and retighten their fittings, if a brake fluid leak is detected. Replace applicable part with a new one, if a damaged part is detected.

A
B
C
D
E
BR
G
H
I
J
K
L
M
N
O
P

BRAKE TUBE AND HOSE

< ON-VEHICLE REPAIR >

1. Check brake lines (tubes and hoses), and connections for fluid leaks, damage, twist, deformation, contact with other parts, and loose connections. Replace any parts as necessary. Refer to [BR-13, "Hydraulic Circuit"](#).
2. While depressing brake pedal under a force of 785 N (80 kg-f, 177 lb-f) with engine running for approximately 5 seconds, check each part for fluid leaks.

BRAKE MASTER CYLINDER

< ON-VEHICLE REPAIR >

BRAKE MASTER CYLINDER

Removal and Installation

INFOID:000000004918372

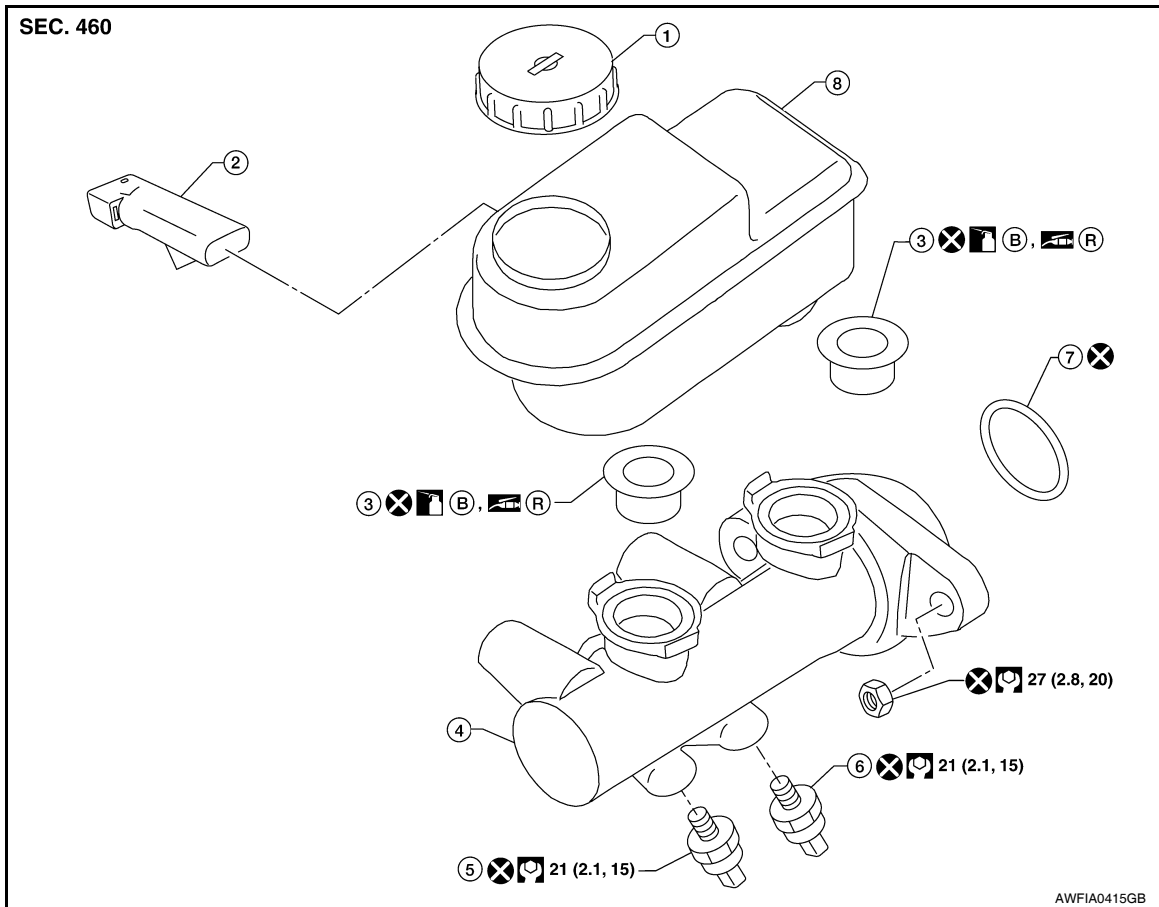

- | | | |
|-----------------------------|--------------------------|-------------------------|
| 1. Reservoir cap | 2. Fluid level sensor | 3. Grommet |
| 4. Master cylinder assembly | 5. Front pressure sensor | 6. Rear pressure sensor |
| 7. Seal | 8. Reservoir tank | B. Brake fluid |
| R. Rubber grease | | |

REMOVAL

CAUTION:

- Be careful not to splash brake fluid on painted areas; it may cause paint damage. If brake fluid is splashed on painted areas, wash it away with water immediately.
- Before removing brake master cylinder, depress the brake pedal 5-6 times with the key OFF to deplete vacuum in the booster.

1. Remove brake reservoir cap.
2. Disconnect harness connectors for fluid level sensor, front and rear pressure sensors.
3. Using suitable tool, disconnect brake tube from master cylinder assembly.
4. Remove master cylinder assembly nuts, and remove master cylinder assembly.

INSTALLATION

Installation is in the reverse order of removal.

- Refill brake fluid and bleed air. Refer to [BR-17. "Bleeding Brake System"](#).

CAUTION:

- Refill with new brake fluid. Refer to [MA-19. "FOR NORTH AMERICA : Fluids and Lubricants"](#).
- Do not reuse drained brake fluid.
- Adjust brake pedal. Refer to [BR-15. "Inspection and Adjustment"](#).

BRAKE BOOSTER

< ON-VEHICLE REPAIR >

BRAKE BOOSTER

Removal and Installation

INFOID:000000004918373

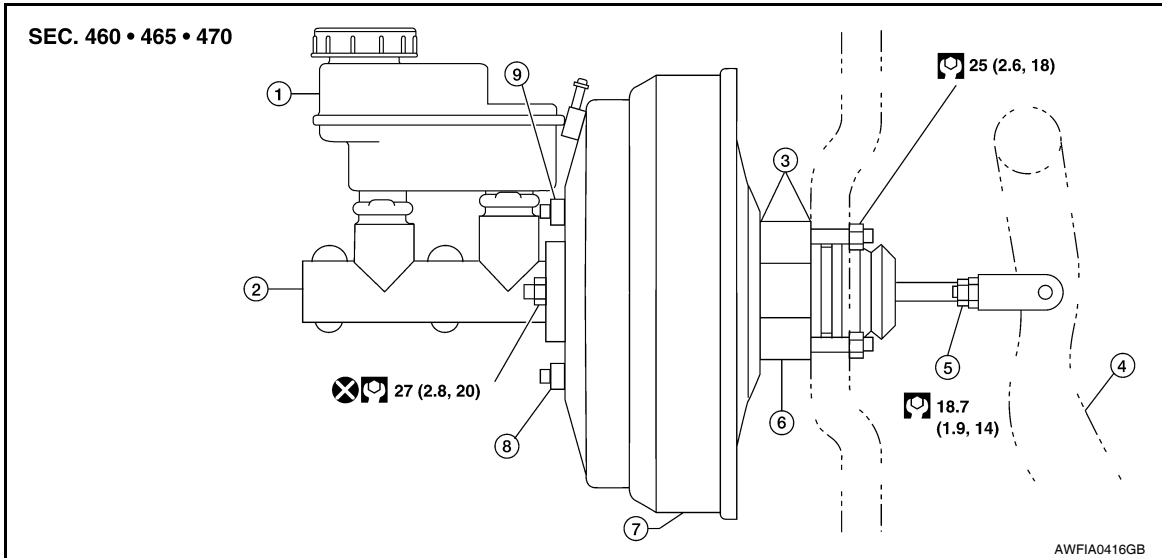

- | | | |
|-------------------|-----------------------------|------------------------|
| 1. Reservoir tank | 2. Master cylinder assembly | 3. Gasket |
| 4. Brake pedal | 5. Lock nut | 6. Spacer block |
| 7. Brake booster | 8. Active booster | 9. Delta stroke sensor |

CAUTION:

- Be careful not to deform or bend brake piping while removing and installing brake booster.
- Replace clevis pin if it is damaged.
- Be careful not to damage brake booster stud bolt threads. If brake booster is tilted or inclined during installation, dash panel may damage the threads.
- Attach the check valve in the correct direction.

REMOVAL

1. Remove engine room cover with power tool. Refer to [EM-24. "Removal and Installation"](#).
2. Remove engine air duct assembly. Refer to [EM-25. "Removal and Installation"](#).
3. Remove cowl top extension. Refer to [EXT-18. "Removal and Installation"](#).
4. Remove master cylinder assembly from brake booster. Refer to [BR-25. "Removal and Installation"](#).
5. Remove vacuum hose from brake booster. Refer to [BR-28. "Removal and Installation"](#).
6. Disconnect active boost and delta stroke sensor harness connectors from brake booster.
7. Remove the instrument lower panel LH. Refer to [JP-11. "Exploded View"](#).
8. Remove brake pedal to clevis attachment snap pin and clevis pin from inside the vehicle.
9. Remove brake booster to brake pedal assembly nuts.
10. Reposition the A/C line out of the way.
11. Remove brake booster and spacer block from dash panel.

INSPECTION AFTER REMOVAL

Output Rod Length Inspection

BRAKE BOOSTER

< ON-VEHICLE REPAIR >

1. Using a hand vacuum pump, apply a vacuum of -66.7 kPa (-500 mmHg, -19.69 inHg) to brake booster.
2. Check output rod length.

Output rod length : Refer to [BR-46, "Brake Booster"](#).

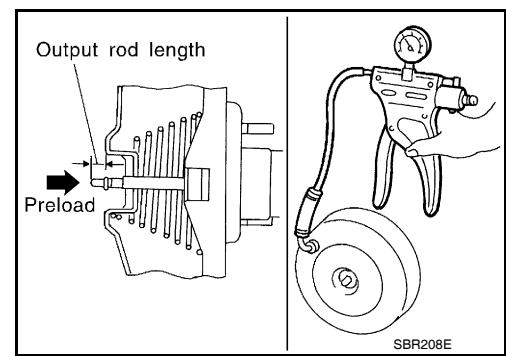

INSTALLATION

1. Loosen lock nut to adjust input rod length so that the length (B) is set at the specified value.

Input rod length (B) : Refer to [BR-46, "Brake Booster"](#).

2. After adjusting length (B), temporarily tighten lock nut and install brake booster and spacer block.
 - Install the gaskets and spacer block between brake booster and dash panel.
3. Connect brake pedal to clevis on the input rod.
4. Install brake booster to brake pedal assembly nuts and tighten to the specified torque.
5. Connect active boost and delta stroke sensor harness connectors to brake booster.
6. Connect vacuum hose to brake booster.
7. Install master cylinder assembly to brake booster. Refer to [BR-25, "Removal and Installation"](#).
8. Adjust the height and play of brake pedal. Refer to [BR-15, "Inspection and Adjustment"](#).
9. Tighten lock nut of input rod to specification.
10. Install the instrument lower panel LH. Refer to [IP-11, "Exploded View"](#).
11. Secure A/C line into clips.
12. Install cowl top extension. Refer to [EXT-18, "Removal and Installation"](#).
13. Install engine air duct assembly. Refer to [EM-25, "Removal and Installation"](#).
14. Install engine room cover. Refer to [EM-24, "Removal and Installation"](#).
15. Refill with new brake fluid and bleed air. Refer to [BR-17, "Bleeding Brake System"](#).

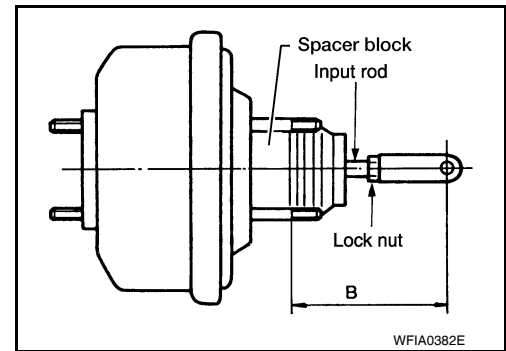

VACUUM LINES

< ON-VEHICLE REPAIR >

VACUUM LINES

Removal and Installation

INFOID:000000004918374

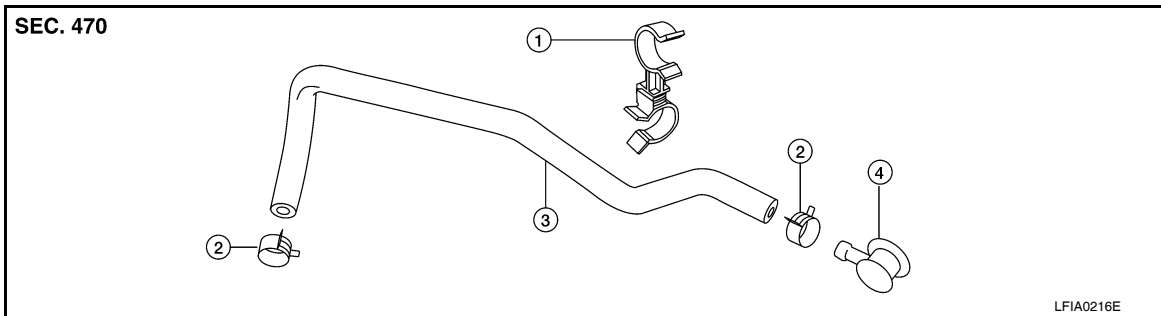

1. Hose clip
2. Clamp
3. Vacuum hose
4. Check valve

REMOVAL

1. Remove engine room cover. Refer to [EM-24. "Removal and Installation"](#).
2. Disconnect vacuum hose from hose clip.
3. Release clamps and disconnect vacuum hose.
4. Remove check valve from brake booster.

INSTALLATION

Installation is in the reverse order of removal.

CAUTION:

- Insert vacuum hose over the tube for 24 mm (0.94 in) or more.
- Do not use lubricating oil during assembly.

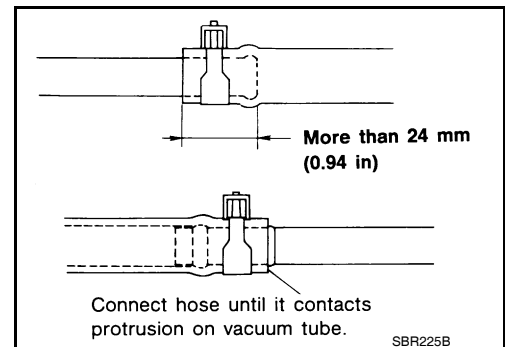

FRONT DISC BRAKE

< ON-VEHICLE REPAIR >

FRONT DISC BRAKE

Exploded View of Brake Pads

INFOID:000000004918375

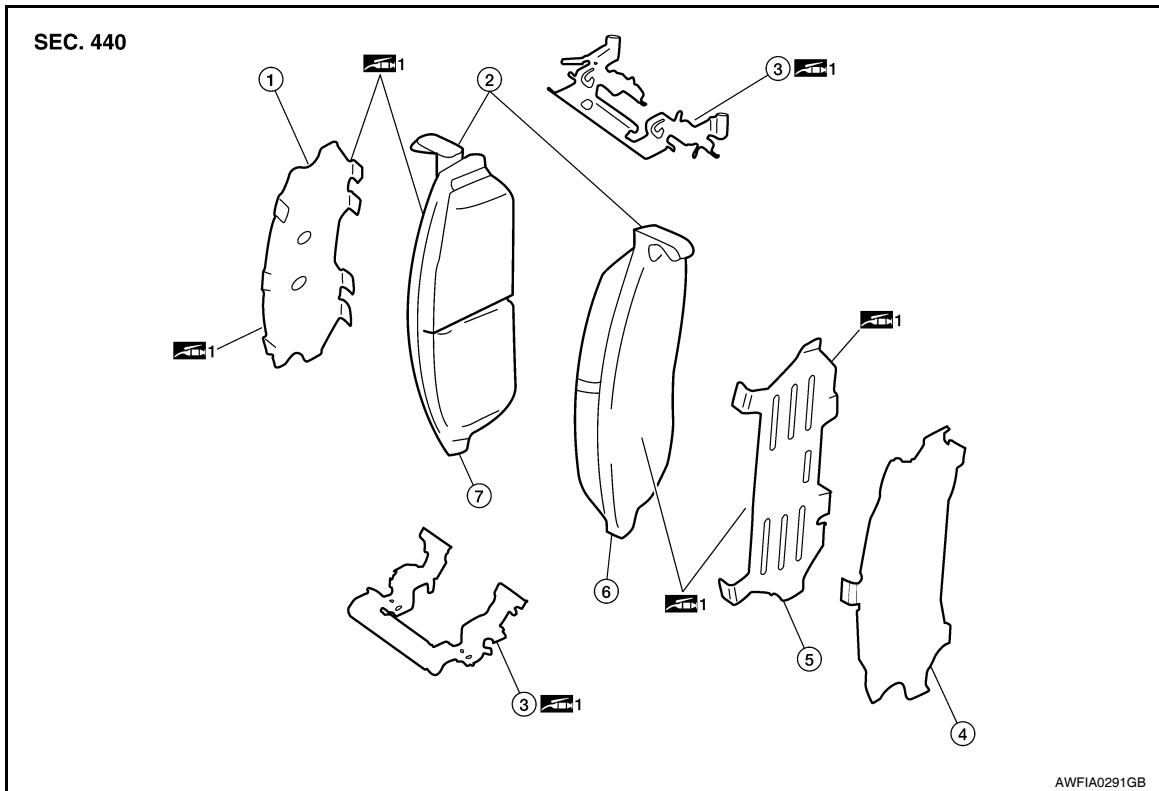

- | | | |
|-----------------------------|-------------------------|-----------------|
| 1. Inner multi-layered shim | 2. Pad wear sensor | 3. Pad retainer |
| 4. Outer shim cover | 5. Outer shim | 6. Outer pad |
| 7. Inner pad | 1: Molykote M-77 grease | |

Removal and Installation of Brake Pads

INFOID:000000004918376

WARNING:

Clean dust on caliper and brake pad with a vacuum dust collector to minimize the hazard of air borne particles or other materials.

CAUTION:

- While removing cylinder body, do not depress brake pedal because piston will pop out.
- It is not necessary to remove bolts on torque member and brake hose except for disassembly or replacement of caliper assembly. In this case, hang cylinder body with a wire so as not to stretch brake hose.
- Do not damage piston boot.
- If any shim is subject to serious corrosion, replace it with a new one.
- Always replace shim and shim cover as a set when replacing brake pads.
- Keep rotor free from brake fluid.
- Burnish the brake pads and disc rotor mutually contacting surfaces, after refinishing or replacing rotors, after replacing pads, or if a soft pedal occurs at very low mileage.

REMOVAL

1. Remove front wheel and tires using power tool. Refer to [WT-50. "Rotation"](#).
2. Partially drain some brake fluid from the reservoir.
3. Remove the sliding pin bolts.

A
B
C
D
E
BR
G
H
I
J
K
L
M
N
O
P

FRONT DISC BRAKE

< ON-VEHICLE REPAIR >

4. Hang cylinder body with a wire, and remove pads, pad retainers, shims, and shim cover from torque member.

CAUTION:

When removing the pad retainer from the torque member, lift it in the direction indicated by the arrow as shown so that it does not deform.

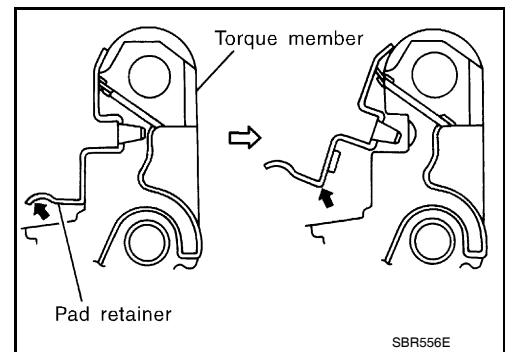

INSTALLATION

1. Push pistons in using suitable tool.

CAUTION:

By pushing in pistons, brake fluid returns to master cylinder reservoir tank. Watch the brake fluid level in the reservoir tank.

NOTE:

Using a suitable tool, makes it easier to push in the pistons.

2. Apply Molykote M-77 grease or equivalent to between shim cover and shim. Install outer shim, outer shim cover to inner pad, and inner multi-layered shim to outer pad.
3. Apply Molykote M-77 grease or equivalent to between pad retainer and pad. Install pad retainers and pads to torque member.
4. Apply Molykote M-77 grease or equivalent to the piston face. Install pad return lever securely to pad wear sensor as shown.

CAUTION:

- Securely assemble pad retainers so that they are not being lifted up from torque member.
- Both inner and outer pads have a pad return system on the pad retainer. Install pad return lever securely to pad wear sensor.

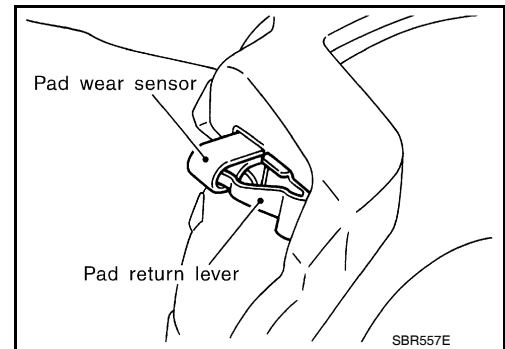

5. Install pads to cylinder body.
6. Install cylinder body to torque member.

CAUTION:

In the case of replacing a pad with new one, check the brake fluid level in the reservoir tank because brake fluid returns to reservoir tank when pressing piston in.

NOTE:

Use a suitable tool to easily press piston.

7. Apply rubber grease and install sliding pin bolts, and tighten it to the specified torque. Refer to [BR-29, "Exploded View of Brake Pads"](#).
8. Check front disc brake for drag.
9. Install front wheel and tires. Refer to [WT-50, "Rotation"](#).

Brake Burnishing Procedure

INFOID:000000004918377

Burnish contact surfaces between disc rotors and pads according to following procedure after refinishing or replacing rotors, after replacing pads, or if a soft pedal occurs at very low mileage.

CAUTION:

- Be careful of vehicle speed because the brake does not operate easily until pad and disc rotor are securely seated.
 - Only perform this procedure under safe road and traffic conditions. Use extreme caution.
1. Drive vehicle on straight, flat road.
 2. Depress brake pedal with the power to stop vehicle within 3 to 5 seconds until the vehicle stops.
 3. Drive without depressing brake for a few minutes to cool the brake.
 4. Repeat steps 1 through 3 until pad and disc rotor are securely seated.

FRONT DISC BRAKE

< ON-VEHICLE REPAIR >

Exploded View of Brake Caliper

INFOID:000000004918378

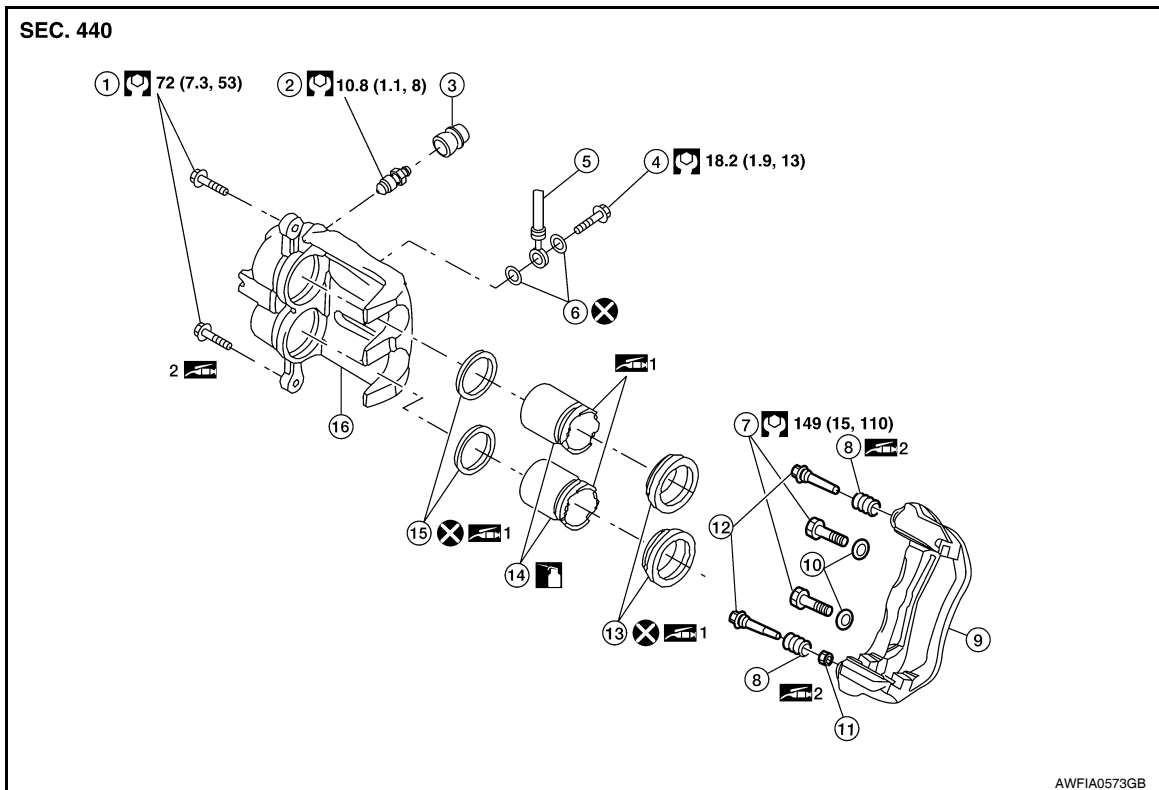

- | | | |
|-----------------------|---------------------|-------------------------|
| 1. Sliding pin bolt | 2. Bleed valve | 3. Cap |
| 4. Union bolt | 5. Brake hose | 6. Copper washer |
| 7. Torque member bolt | 8. Sliding pin boot | 9. Torque member |
| 10. Washers | 11. Bushing | 12. Sliding pin |
| 13. Piston boot | 14. Piston | 15. Piston seal |
| 16. Cylinder body | Brake fluid | 1: Molykote M-77 grease |
| 2: Rubber grease | | |

Removal and Installation of Brake Caliper and Rotor

INFOID:000000004918379

WARNING:

Clean dust on caliper and brake pad with a vacuum dust collector to minimize the hazard of air borne particles or other materials.

CAUTION:

- While removing cylinder body, do not depress brake pedal because piston will pop out.
- Do not damage piston boot.
- Keep rotor free from brake fluid.
- Refill with new specified brake fluid.
- Burnish brake contact surface after refinishing or replacing rotors, after replacing pads, or if a soft pedal occurs at very low mileage. Refer to [BR-30, "Brake Burnishing Procedure"](#).

REMOVAL

1. Remove front wheel and tire using power tool. Refer to [WT-50, "Rotation"](#).
2. Fasten disc rotor using wheel nut.
3. Remove brake reservoir cap.
4. Remove union bolt, and then disconnect brake hose from caliper assembly.

NOTE:

Discard the copper washers, do not reuse.

FRONT DISC BRAKE

< ON-VEHICLE REPAIR >

5. Remove torque member bolts, and remove brake caliper assembly.

CAUTION:

Do not drop brake pad.

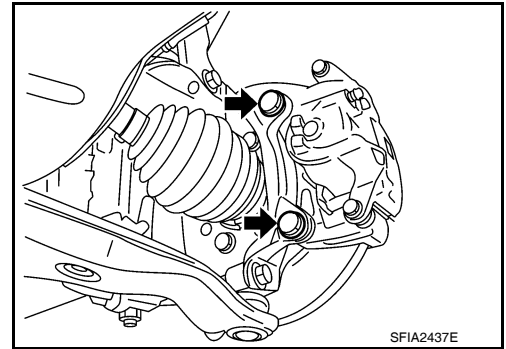

6. Apply matching marks to disc rotor and wheel hub assembly as shown if the disc rotor is to be reused, then remove disc rotor.

CAUTION:

Put matching marks on wheel hub assembly and disc rotor if the disc rotor is to be reused.

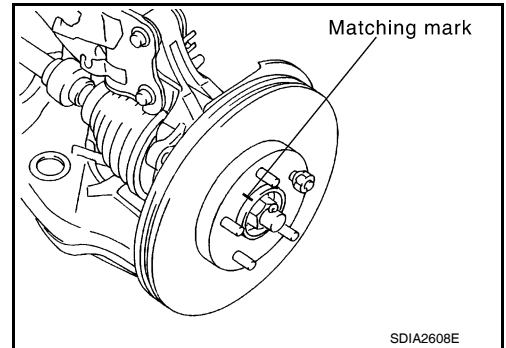

INSTALLATION

1. If reusing the disc rotor, use the matching marks to align disc rotor on the wheel hub assembly as shown, then install disc rotor using a wheel nut to hold it in place.

CAUTION:

Use matching marks on wheel hub assembly and disc rotor if the disc rotor is to be reused.

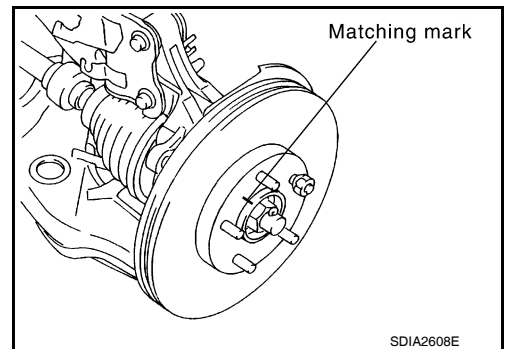

2. Install brake caliper assembly to vehicle, and tighten torque member bolts to the specified torque.

CAUTION:

Do not allow oil or any moisture on all contact surfaces between steering knuckle and caliper assembly, bolts, and washer.

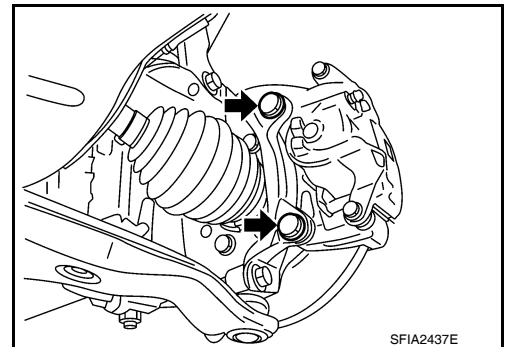

FRONT DISC BRAKE

< ON-VEHICLE REPAIR >

3. Install brake hose to brake caliper assembly using new copper washers. Align the brake hose to the projection as shown and tighten union bolts to the specified torque.

CAUTION:

- Do not reuse copper washers.
- Securely attach brake hose to projection on cylinder body.

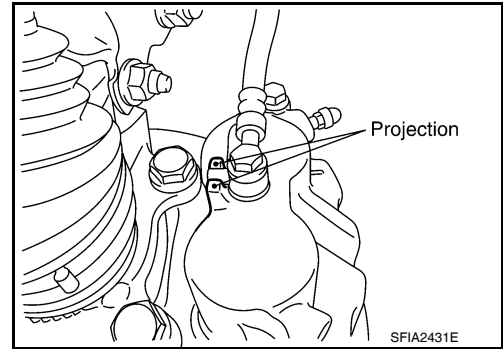

4. Refill with new brake fluid and bleed air. Refer to [BR-17. "Bleeding Brake System"](#).
5. Check front disc brake for drag and correct as necessary.
6. Install front wheel and tire. Refer to [WT-50. "Rotation"](#).

A
B
C
D
E
G
H
I
J
K
L
M
N
O
P

BR

REAR DISC BRAKE

< ON-VEHICLE REPAIR >

REAR DISC BRAKE

Exploded View of Brake Pads

INFOID:000000004918380

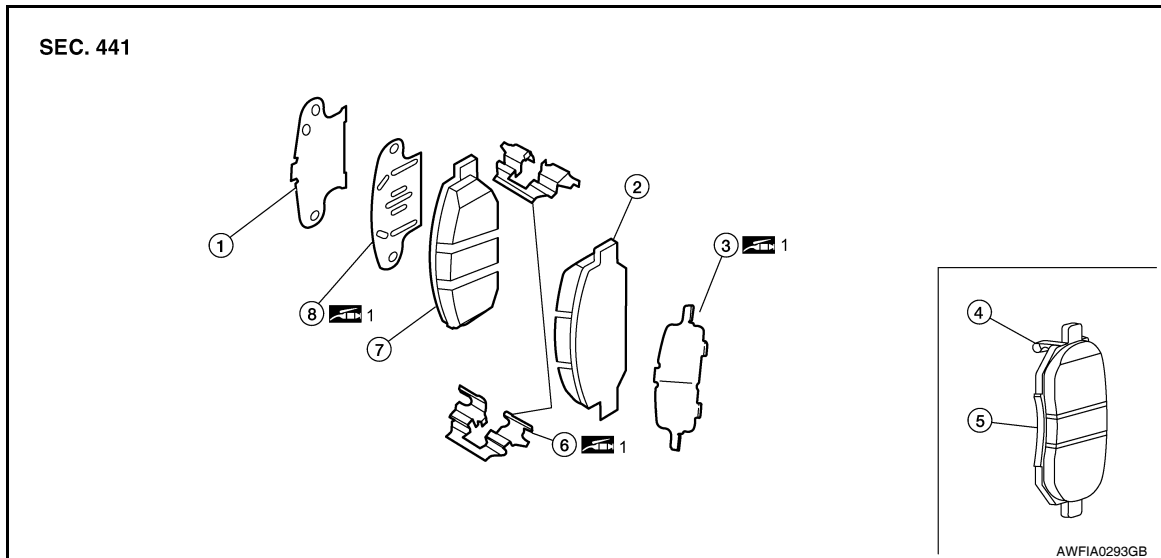

- | | | |
|---------------------|-------------------|-----------------------------|
| 1. Inner shim cover | 2. Outer pad | 3. Outer multi-layered shim |
| 4. Pad wear sensor | 5. Inner pad (RH) | 6. Pad retainer |
| 7. Inner pad | 8. Inner shim | |

 1: Molykote M-77 grease

Removal and Installation of Brake Pad

INFOID:000000004918381

WARNING:

Clean dust on caliper and brake pad with a vacuum dust collector to minimize the hazard of air borne particles or other materials.

CAUTION:

- While removing cylinder body, do not depress brake pedal because piston will pop out.
- It is not necessary to disconnect brake hose connection except for disassembly or replacement of caliper assembly. In this case, hang cylinder body with a wire so as not to stretch brake hose.
- Do not damage piston boot.
- If any shim is subject to serious corrosion, replace it with a new one.
- Always replace shim and shim cover as a set when replacing brake pads.
- Keep rotor free from brake fluid.
- Burnish the brake pads and disc rotor mutually contacting surfaces, after refinishing or replacing rotors, after replacing pads, or if a soft pedal occurs at very low mileage.

REMOVAL

1. Remove rear wheel and tire using power tool. Refer to [WT-50, "Rotation"](#).
2. Partially drain some brake fluid from the reservoir.
3. Remove the sliding sleeves and sliding pin bolts from the cylinder body.
4. Support the cylinder body with wire, remove pads, shims, cover and retainers.

INSTALLATION

1. Push piston in using suitable tool.

CAUTION:

By pushing in piston, brake fluid returns to master cylinder reservoir tank. Watch the brake fluid level in the reservoir tank.

NOTE:

Using a suitable tool, makes it easier to push in the piston.

REAR DISC BRAKE

< ON-VEHICLE REPAIR >

- Apply Molykote M-77 grease to knuckle slide where brake pad contacts and to the outer multi-layered shim, pad retainers and inner shim.
- CAUTION:**
Do not get grease on the brake pads or brake rotor friction surfaces.
- Install pads, shims, cover and retainers to cylinder body.
- Apply rubber grease to the sliding sleeve and install cylinder body sliding sleeves and sliding pin bolts and tighten to specification.
- Check rear disc brake for drag.
- Install rear wheel and tire. Refer to [WT-50, "Rotation"](#).

Brake Burnishing Procedure

INFOID:000000004918382

Burnish contact surfaces between disc rotors and pads according to following procedure after refinishing or replacing rotors, after replacing pads, or if a soft pedal occurs at very low mileage.

CAUTION:

- Be careful of vehicle speed because the brake does not operate easily until pad and disc rotor are securely seated.
 - Only perform this procedure under safe road and traffic conditions. Use extreme caution.
- Drive vehicle on straight, flat road.
 - Depress brake pedal with the power to stop vehicle within 3 to 5 seconds until the vehicle stops.
 - Drive without depressing brake for a few minutes to cool the brake.
 - Repeat steps 1 through 3 until pad and disc rotor are securely seated.

Exploded View of Brake Caliper

INFOID:000000004918383

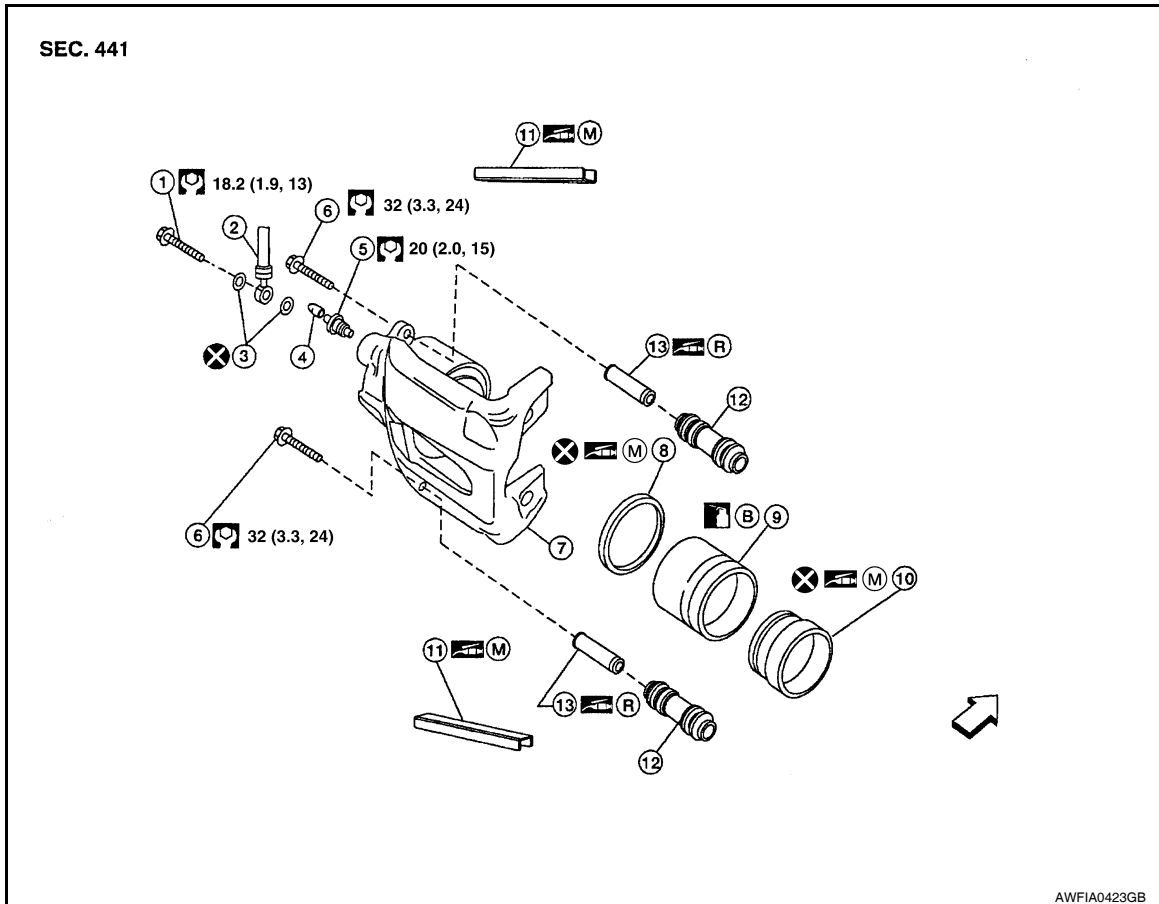

- | | | |
|------------------|-------------------|-------------------------|
| 1. Union bolt | 2. Brake hose | 3. Copper washer |
| 4. Cap | 5. Bleed valve | 6. Sliding pin bolt |
| 7. Cylinder body | 8. Piston seal | 9. Piston |
| 10. Piston boot | 11. Knuckle slide | 12. Sliding sleeve boot |

REAR DISC BRAKE

< ON-VEHICLE REPAIR >

13. Sliding sleeve
M. Molykote M-77

B. Brake fluid
↶ Front

R. Rubber grease

Removal and Installation of Brake Caliper and Disc Rotor

INFOID:000000004918384

WARNING:

Clean dust on caliper and brake pad with a vacuum dust collector to minimize the hazard of air borne particles or other materials.

CAUTION:

- While removing cylinder body, do not depress brake pedal because piston will pop out.
- Do not damage piston boot.
- Keep rotor free from brake fluid.
- Refill with new specified brake fluid.
- Burnish brake contact surface after refinishing or replacing rotors, after replacing pads, or if a soft pedal occurs at very low mileage. Refer to [BR-35, "Brake Burnishing Procedure"](#).

REMOVAL

1. Remove rear wheel and tire using power tool. Refer to [WT-50, "Rotation"](#).
2. Fasten disc rotor using wheel nut.
3. Remove brake reservoir cap.
4. Remove union bolt and cylinder body bolts, then remove cylinder body.

NOTE:

Discard the copper washers, do not reuse.

5. Apply matching marks to disc rotor and wheel hub assembly if the disc rotor is to be reused, then remove disc rotor.

CAUTION:

Put matching marks on wheel hub assembly and disc rotor if the disc rotor is to be reused.

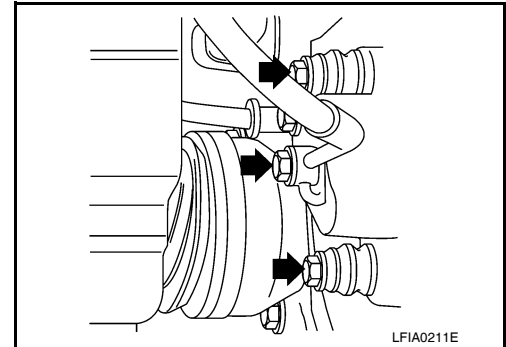

INSTALLATION

1. If reusing the disc rotor, use the matching marks to align disc rotor on the wheel hub assembly, then install disc rotor using a wheel nut to hold it in place.

CAUTION:

Use matching marks on wheel hub assembly and disc rotor if the disc rotor is to be reused.

2. Install cylinder body and tighten cylinder body bolts to specification.

CAUTION:

Before installing cylinder body to the vehicle, wipe off mating surface of cylinder body.

3. Install brake hose to cylinder body with new copper washers and tighten union bolt to specification.

CAUTION:

- Do not reuse copper washers.
- Securely attach brake hose to projection on cylinder body.

4. Refill with new brake fluid and bleed. Refer to [BR-17, "Bleeding Brake System"](#).
5. Check rear disc brake for drag and correct as necessary.
6. Install rear wheel and tire. Refer to [WT-50, "Rotation"](#).

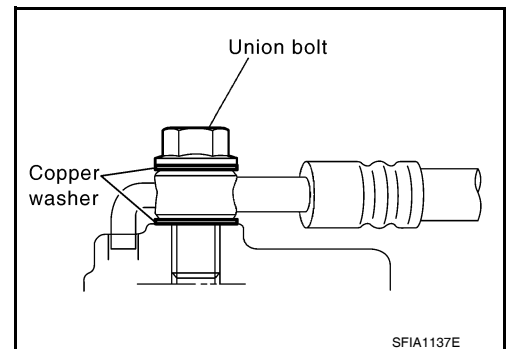

BRAKE MASTER CYLINDER

< DISASSEMBLY AND ASSEMBLY >

DISASSEMBLY AND ASSEMBLY

BRAKE MASTER CYLINDER

Disassembly and Assembly

INFOID:000000004918385

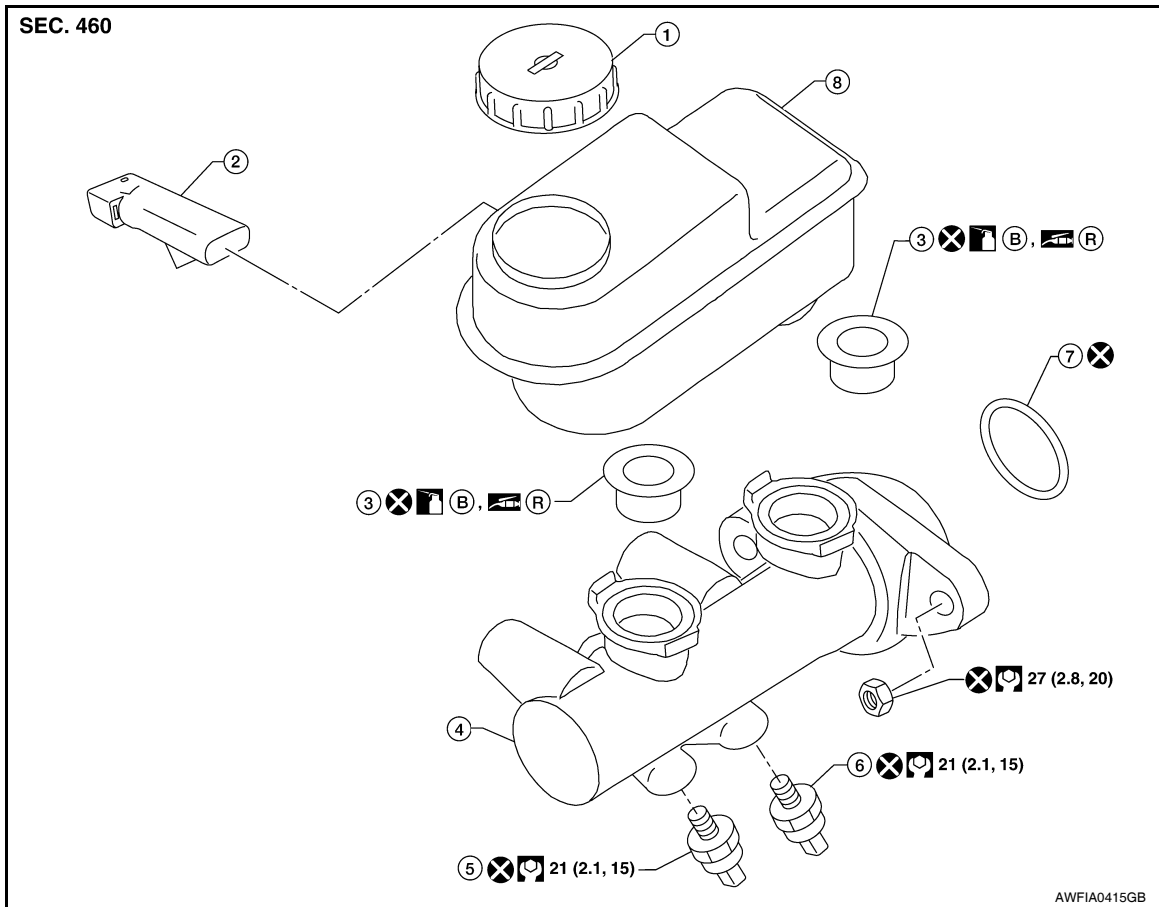

- | | | |
|-----------------------------|--------------------------|-------------------------|
| 1. Reservoir cap | 2. Fluid level sensor | 3. Grommet |
| 4. Master cylinder assembly | 5. Front pressure sensor | 6. Rear pressure sensor |
| 7. Seal | 8. Reservoir tank | B. Brake fluid |
| R. Rubber grease | | |

DISASSEMBLY

CAUTION:

- Master cylinder assembly cannot be disassembled.
- Do not drop parts. If a part is dropped, do not use it.

1. Pull the reservoir tank off the master cylinder assembly.
2. Remove the grommets from master cylinder assembly and discard the grommets.

CAUTION:

Discard the grommets, do not reuse.

3. Remove the fluid level sensor from the reservoir tank.
4. Remove the front and rear pressure sensors and discard.

CAUTION:

Discard the front and rear pressure sensors, do not reuse.

ASSEMBLY

CAUTION:

- Never use mineral oil such as kerosene, gasoline during the cleaning and assembly process.
- Do not drop parts. If a part is dropped, do not use it.

BRAKE MASTER CYLINDER

< DISASSEMBLY AND ASSEMBLY >

1. Apply brake fluid or rubber grease to the new grommets, then insert the new grommets into the master cylinder assembly.

CAUTION:

Do not reuse the grommets.

2. Install the reservoir tank onto the master cylinder assembly.
3. Install the fluid level sensor on the reservoir tank.
4. Install the new front and rear pressure sensors.

CAUTION:

Do not reuse the front and rear pressure sensors.

FRONT DISC BRAKE

< DISASSEMBLY AND ASSEMBLY >

FRONT DISC BRAKE

Disassembly and Assembly

INFOID:000000004918386

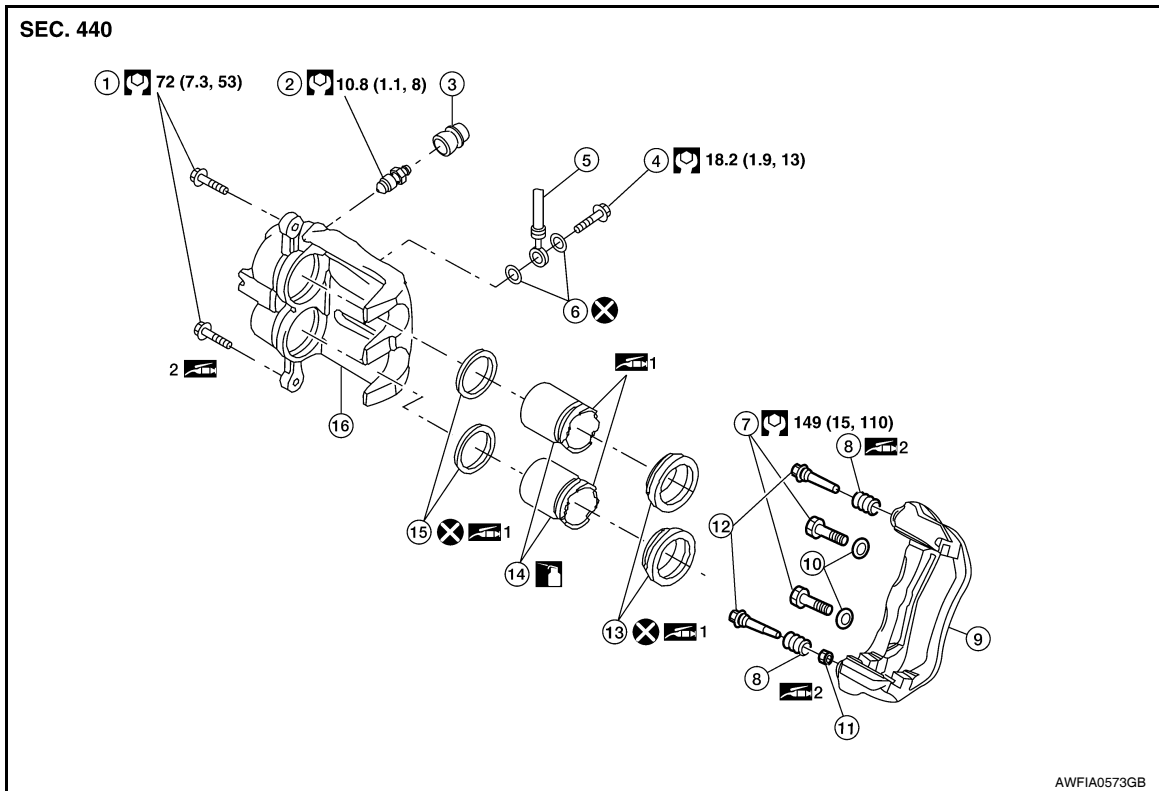

- | | | |
|-----------------------|---------------------|-------------------------|
| 1. Sliding pin bolt | 2. Bleed valve | 3. Cap |
| 4. Union bolt | 5. Brake hose | 6. Copper washer |
| 7. Torque member bolt | 8. Sliding pin boot | 9. Torque member |
| 10. Washers | 11. Bushing | 12. Sliding pin |
| 13. Piston boot | 14. Piston | 15. Piston seal |
| 16. Cylinder body | Brake fluid | 1: Molykote M-77 grease |
| | 2: Rubber grease | |

DISASSEMBLY

1. Remove sliding pin bolt, and then remove the pad, shim, shim cover, and pad retainer from the torque member.
2. Remove sliding pins and sliding pin boots from torque member.
3. Place a wooden block as shown, and blow air from union bolt hole to remove pistons and piston boots.

CAUTION:

Do not get your fingers caught in piston.

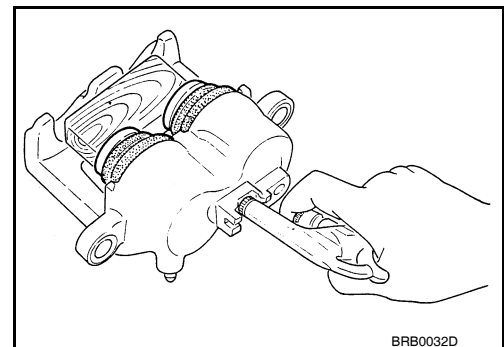

BRB0032D

FRONT DISC BRAKE

< DISASSEMBLY AND ASSEMBLY >

4. Remove piston seals from cylinder body, using a suitable tool.

CAUTION:

- Be careful not to damage cylinder inner wall.
- Do not reuse piston seals.

5. Remove the bleed valve and cap.

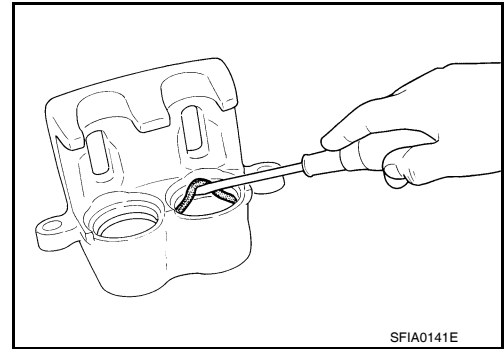

CALIPER INSPECTION

Cylinder Body

Check inside surface of cylinder for score, rust, wear, damage or foreign materials. If any of the above conditions are observed, replace cylinder body.

Minor damage from rust or foreign materials may be eliminated by polishing surface with a fine emery paper. Replace cylinder body if necessary.

CAUTION:

Use new brake fluid for cleaning. Do not use mineral oils such as gasoline or kerosene.

Torque Member

Check for wear, cracks, and damage. If damage or deformation is present, replace the affected part.

Piston

Check piston for score, rust, wear, damage or presence of foreign materials. Replace if any of the above conditions are observed.

CAUTION:

Piston sliding surface is plated, do not polish with emery paper even if rust or foreign materials are stuck to sliding surface.

Sliding Pins, and Sliding Pin Boots

Check sliding pin and sliding pin boot for wear, damage, and cracks. If damage or deformation is present, replace the affected part.

CAUTION:

Trailing/upper sliding pin must be replaced at each service.

ASSEMBLY

CAUTION:

Do not use NISSAN Rubber Grease (KRE00 00010, KRE00 00010 01) when assembling.

1. Install the bleed valve and cap.
2. Apply Molykote M-77 grease to new piston seals and insert seals into grooves on cylinder body.

CAUTION:

Do not reuse piston seals.

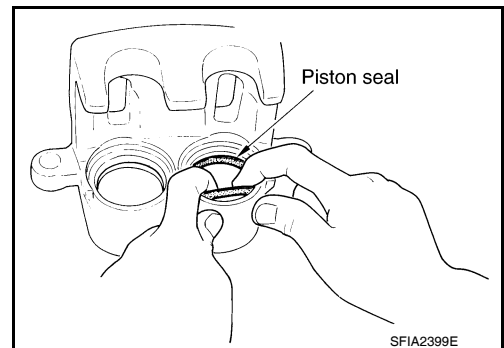

FRONT DISC BRAKE

< DISASSEMBLY AND ASSEMBLY >

3. Apply Molykote M-77 grease to piston boots. Cover the piston ends with piston boots, and then install cylinder side lip on piston boots securely into the grooves on cylinder body.

CAUTION:

Do not reuse piston boots.

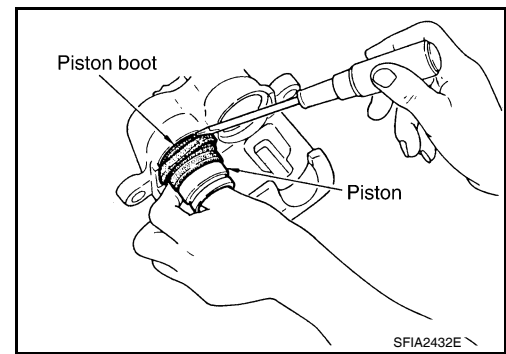

4. Apply clean brake fluid to pistons, then install pistons into cylinder body and insert piston boot side lip into groove of pistons as shown.

CAUTION:

Press the pistons evenly to prevent damage to cylinder wall.

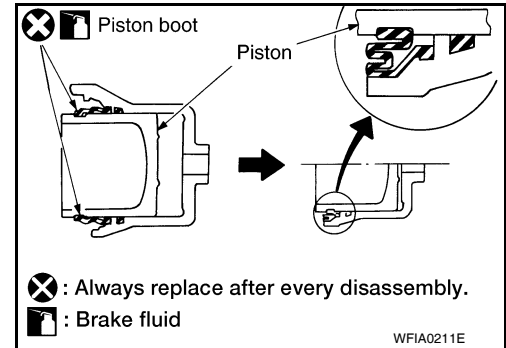

5. Insert into cylinder body by hand and insert piston boot piston-side lip into piston groove.

CAUTION:

Press pistons evenly and vary the pressing point to prevent cylinder inner wall from being rubbed.

6. Apply rubber grease and install new sliding pins, bushing and sliding pin boots to torque member.
7. Install cylinder body. Tighten sliding pin bolts to the specified torque.

REAR DISC BRAKE

< DISASSEMBLY AND ASSEMBLY >

REAR DISC BRAKE

Disassembly and Assembly

INFOID:000000004918387

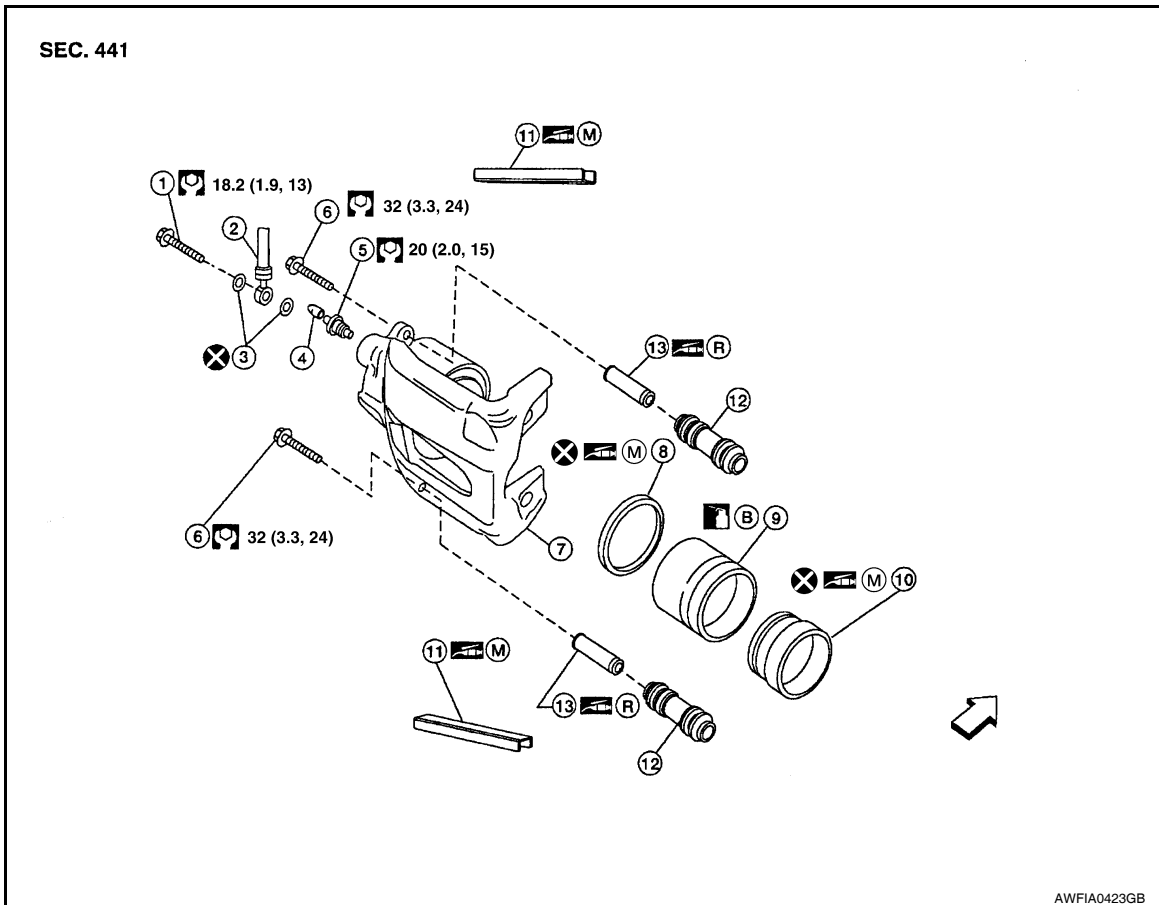

- | | | |
|--------------------|-------------------|-------------------------|
| 1. Union bolt | 2. Brake hose | 3. Copper washer |
| 4. Cap | 5. Bleed valve | 6. Sliding pin bolt |
| 7. Cylinder body | 8. Piston seal | 9. Piston |
| 10. Piston boot | 11. Knuckle slide | 12. Sliding sleeve boot |
| 13. Sliding sleeve | B. Brake fluid | R. Rubber grease |
| M. Molykote M-77 | ← Front | |

DISASSEMBLY

1. Remove pads from cylinder body.
2. Remove sliding sleeve and boot from cylinder body.
3. Place a wooden block as shown, and blow air into union bolt hole to remove piston and piston boot.

CAUTION:

Do not get your fingers caught in piston.

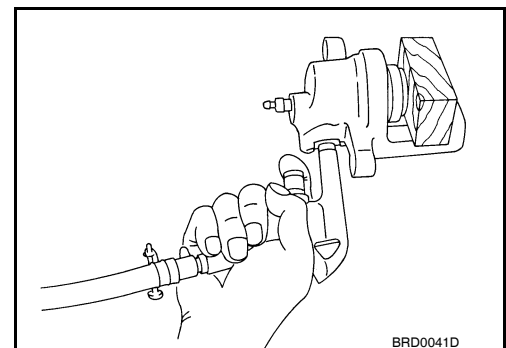

REAR DISC BRAKE

< DISASSEMBLY AND ASSEMBLY >

- Using a suitable tool, remove piston seal from cylinder body as shown.
CAUTION:
Be careful not to damage cylinder body inner wall.
- Remove the bleed valve and cap.

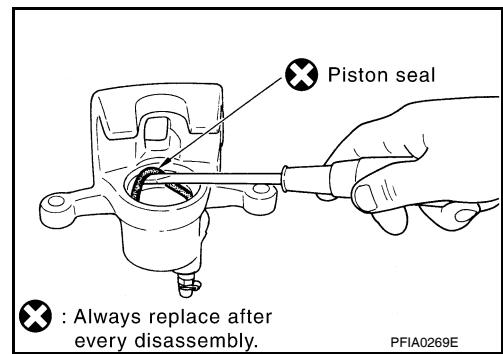

CALIPER INSPECTION

Cylinder Body

Check inside surface of cylinder body for score, rust wear, damage or foreign materials. If any of the above conditions are observed, replace cylinder body. Minor damage from rust or foreign materials may be eliminated by polishing surface with a fine emery paper. Replace cylinder body if necessary.

CAUTION:

- Use new brake fluid to clean. Do not use mineral oils such as gasoline or kerosene.

Torque Member

Check for wear, cracks, and damage. If damage or deformation is present, replace the affected part.

Piston

Check piston for score, rust, wear, damage or presence of foreign materials. Replace if any of the above conditions are observed.

CAUTION:

- Piston sliding surface is plated, do not polish with emery paper even if rust or foreign materials are stuck to sliding surface.

Sliding Pin Bolts and Sliding Pin Boots

Make sure there is no wear, damage, or cracks in sliding sleeve and sliding sleeve boots, and if there are, replace them.

ASSEMBLY

CAUTION:

Do not use NISSAN Rubber Grease (KRE00 00010, KRE00 00010 01) when assembling.

- Install the bleed valve and cap.
- Apply clean brake fluid to new piston seal and insert in to groove on cylinder body.

CAUTION:

Do not reuse piston seal.

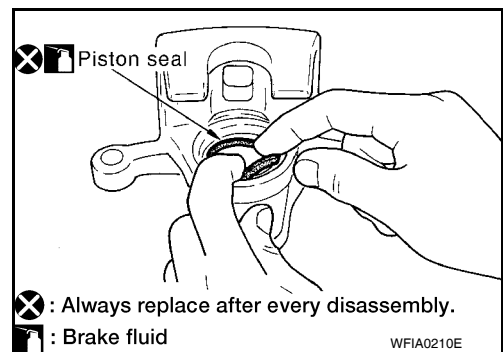

REAR DISC BRAKE

< DISASSEMBLY AND ASSEMBLY >

3. Apply clean brake fluid to piston and to piston boot, then install piston boot in to piston groove.

CAUTION:

Do not reuse piston boot.

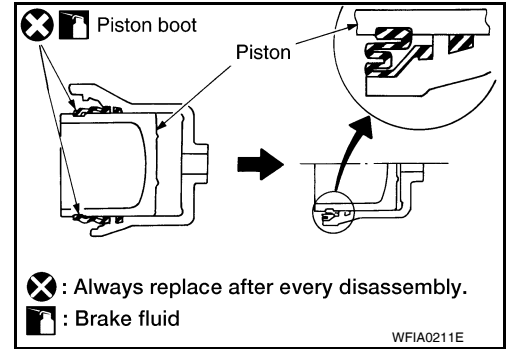

4. Insert into cylinder body by hand and insert piston boot piston-side lip into piston groove.
CAUTION:
Press piston evenly and vary the pressing point to prevent cylinder body inner wall from being rubbed.
5. Apply rubber grease to sliding sleeves, then install sliding boots and sleeves to cylinder body.

SERVICE DATA AND SPECIFICATIONS (SDS)

< SERVICE DATA AND SPECIFICATIONS (SDS)

SERVICE DATA AND SPECIFICATIONS (SDS)

SERVICE DATA AND SPECIFICATIONS (SDS)

General Specification

INFOID:000000004918388

Unit: mm (in)

Front brake	Brake model	AD41VA
	Rotor outer diameter × thickness	350 x 30 (13.78 x 1.181)
	Pad Length × width × thickness	151.6 x 56.5 x 12.0 (5.97 x 2.22 x 0.476)
	Cylinder bore diameter	50.8 (2.00)
Rear brake	Brake model	AD14VE
	Rotor outer diameter × thickness	320 x 14 (12.60 x 0.551)
	Pad Length × width × thickness	83.0 x 33.0 x 12.0 (3.268 x 1.299 x 0.472)
	Cylinder bore diameter	48 (1.89)
Control valve	Valve model	Electric brake force distribution
Brake booster	Booster model	C215T
	Diaphragm diameter	215 (8.46)
Recommended brake fluid		Refer to MA-19. "FOR NORTH AMERICA : Fluids and Lubricants"

Brake Pedal

INFOID:000000004918389

Unit: mm (in)

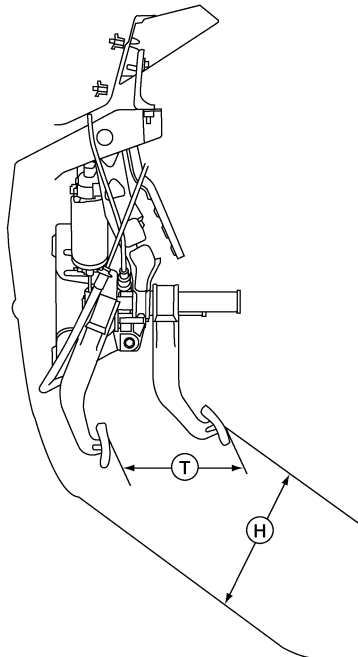

ALFIA0149ZZ

Pedal free height (H) with pedal in forward most position	182.3 - 192.3 (7.18 - 7.57)
Pedal travel (T)	153.3 (6.04)
Stop lamp switch and ASCD cancel switch threaded end to brake pedal bracket gap	0.74 - 1.96 (0.029 - 0.077)

CAUTION:

When equipped with adjustable pedal, the pedal must be in the forward most position (closest to the floor) for pedal height adjustment.

SERVICE DATA AND SPECIFICATIONS (SDS)

< SERVICE DATA AND SPECIFICATIONS (SDS)

Brake Booster

INFOID:000000004918390

Unit: mm (in)

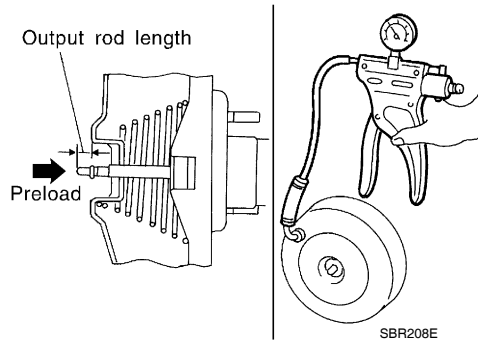

Output rod length [at -66.7 kPa (-500 mmHg, -19.69 inHg) vacuum]	15.6 - 15.9 (0.614 - 0.626)
--	-----------------------------

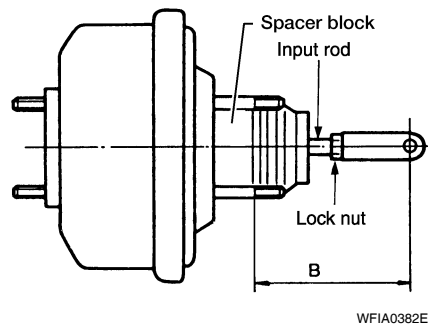

Input rod installation length (B)	151 (5.94)
-----------------------------------	------------

Check Valve

INFOID:000000004918391

Vacuum leakage [at vacuum of - 66.7 kPa(- 500 mmHg, - 19.69 inHg)]	Within 1.3 kPa (10 mmHg, 0.39 inHg) of vacuum for 15 seconds
---	--

Front Disc Brake

INFOID:000000004918392

Unit: mm (in)

Brake model		AD41VA
Brake pad	Standard thickness (new)	12.0 (0.476)
	Repair limit thickness	1.0 (0.039)
Disc rotor	Standard thickness (new)	30 (1.181)
	Repair limit thickness	28 (1.102)
	Maximum uneven wear (measured at 8 positions)	0.015 (0.0006)
	Runout limit (with it attached to the vehicle)	0.03 (0.001)

Rear Disc Brake

INFOID:000000004918393

Unit: mm (in)

Brake model		AD14VE
Brake pad	Standard thickness (new)	12.0 (0.472)
	Repair limit thickness	1.0 (0.039)

SERVICE DATA AND SPECIFICATIONS (SDS)

< SERVICE DATA AND SPECIFICATIONS (SDS)

Brake model		AD14VE
Disc rotor	Standard thickness (new)	14.0 (0.551)
	Repair limit thickness	12.0 (0.472)
	Maximum uneven wear (measured at 8 positions)	0.015 (0.0006)
	Runout limit (with it attached to the vehicle)	0.05 (0.002)

A

B

C

D

E

BR

G

H

I

J

K

L

M

N

O

P