

A
CO
C
D
E
F
G
H
I
J
K
L
M
N
O
P

SECTION CO

ENGINE COOLING SYSTEM

CONTENTS

PRECAUTION	RADIATOR	14	
	Checking Radiator	14	
PRECAUTIONS	ON-VEHICLE REPAIR	15	
Precaution for Supplemental Restraint System (SRS) "AIR BAG" and "SEAT BELT PRE-TENSIONER"	RADIATOR	15	
Precaution Necessary for Steering Wheel Rotation After Battery Disconnect	Exploded View	15	
Precaution for Liquid Gasket	Removal and Installation	15	
PREPARATION	ENGINE COOLING FAN	18	
	Exploded View	18	
PREPARATION	Removal and Installation (Crankshaft Driven Type)	18	
Special Service Tool	Removal and Installation (Motor Driven Type)	19	
Commercial Service Tool	WATER PUMP	20	
FUNCTION DIAGNOSIS	Exploded View	20	
	Removal and Installation	20	
COOLING SYSTEM	THERMOSTAT AND WATER PIPING	22	
Cooling Circuit	Exploded View	22	
Schematic	Removal and Installation	22	
OVERHEATING CAUSE ANALYSIS	SERVICE DATA AND SPECIFICATIONS (SDS)	24	
Troubleshooting Chart	SERVICE DATA AND SPECIFICATIONS (SDS)	24	
ON-VEHICLE MAINTENANCE	Standard and Limit	24	
ENGINE COOLANT			
Inspection			
Changing Engine Coolant			

PRECAUTIONS

< PRECAUTION >

PRECAUTION

PRECAUTIONS

Precaution for Supplemental Restraint System (SRS) "AIR BAG" and "SEAT BELT PRE-TENSIONER"

INFOID:000000005153273

The Supplemental Restraint System such as "AIR BAG" and "SEAT BELT PRE-TENSIONER", used along with a front seat belt, helps to reduce the risk or severity of injury to the driver and front passenger for certain types of collision. This system includes seat belt switch inputs and dual stage front air bag modules. The SRS system uses the seat belt switches to determine the front air bag deployment, and may only deploy one front air bag, depending on the severity of a collision and whether the front occupants are belted or unbelted. Information necessary to service the system safely is included in the SR and SB section of this Service Manual.

WARNING:

- To avoid rendering the SRS inoperative, which could increase the risk of personal injury or death in the event of a collision which would result in air bag inflation, all maintenance must be performed by an authorized NISSAN/INFINITI dealer.
- Improper maintenance, including incorrect removal and installation of the SRS, can lead to personal injury caused by unintentional activation of the system. For removal of Spiral Cable and Air Bag Module, see the SR section.
- Do not use electrical test equipment on any circuit related to the SRS unless instructed to in this Service Manual. SRS wiring harnesses can be identified by yellow and/or orange harnesses or harness connectors.

PRECAUTIONS WHEN USING POWER TOOLS (AIR OR ELECTRIC) AND HAMMERS

WARNING:

- When working near the Airbag Diagnosis Sensor Unit or other Airbag System sensors with the Ignition ON or engine running, DO NOT use air or electric power tools or strike near the sensor(s) with a hammer. Heavy vibration could activate the sensor(s) and deploy the air bag(s), possibly causing serious injury.
- When using air or electric power tools or hammers, always switch the Ignition OFF, disconnect the battery, and wait at least 3 minutes before performing any service.

Precaution Necessary for Steering Wheel Rotation After Battery Disconnect

INFOID:000000005282705

NOTE:

- This Procedure is applied only to models with Intelligent Key system and NATS (NISSAN ANTI-THEFT SYSTEM).
- Remove and install all control units after disconnecting both battery cables with the ignition knob in the "LOCK" position.
- Always use CONSULT-III to perform self-diagnosis as a part of each function inspection after finishing work. If DTC is detected, perform trouble diagnosis according to self-diagnostic results.

For models equipped with the Intelligent Key system and NATS, an electrically controlled steering lock mechanism is adopted on the key cylinder.

For this reason, if the battery is disconnected or if the battery is discharged, the steering wheel will lock and steering wheel rotation will become impossible.

If steering wheel rotation is required when battery power is interrupted, follow the procedure below before starting the repair operation.

OPERATION PROCEDURE

1. Connect both battery cables.

NOTE:

Supply power using jumper cables if battery is discharged.

2. Use the Intelligent Key or mechanical key to turn the ignition switch to the "ACC" position. At this time, the steering lock will be released.
3. Disconnect both battery cables. The steering lock will remain released and the steering wheel can be rotated.
4. Perform the necessary repair operation.

PRECAUTIONS

< PRECAUTION >

- When the repair work is completed, return the ignition switch to the "LOCK" position before connecting the battery cables. (At this time, the steering lock mechanism will engage.)
- Perform a self-diagnosis check of all control units using CONSULT-III.

Precaution for Liquid Gasket

INFOID:000000004918815

REMOVAL OF LIQUID GASKET SEALING

- After removing the bolts and nuts, separate the mating surface and remove the old liquid gasket sealing using Tool.

Tool number : KV10111100 (J-37228)

CAUTION:

Do not damage the mating surfaces.

- Tap the seal cutter to insert it (1).
- In areas where the Tool is difficult to use, lightly tap to slide it (2).

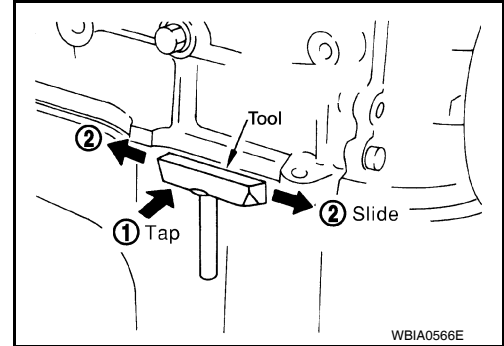

LIQUID GASKET APPLICATION PROCEDURE

- Remove the old liquid gasket adhering to the gasket application surface and the mating surface using suitable tool.
 - Remove the liquid gasket completely from the groove of the liquid gasket application surface, bolts, and bolt holes.
- Thoroughly clean the mating surfaces and remove adhering moisture, grease and foreign material.

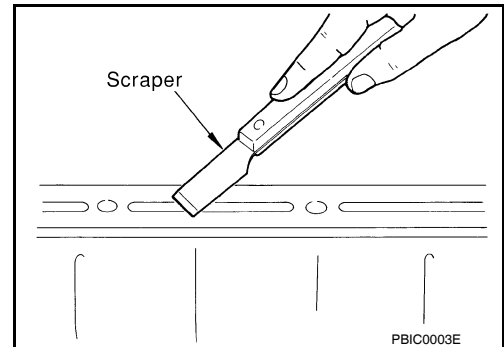

- Attach the liquid gasket tube to the Tool.

Tool number : WS39930000 (—)

Use Genuine RTV Silicone Sealant or equivalent. Refer to [GI-15, "Recommended Chemical Products and Sealants"](#).

- Apply the liquid gasket without breaks to the specified location.

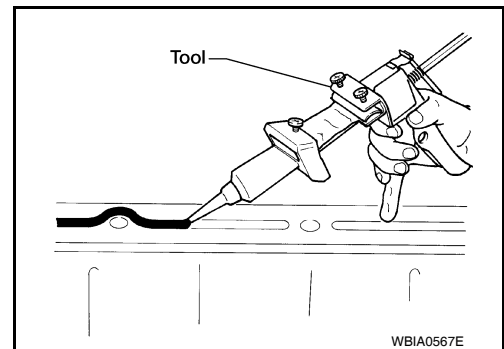

- If there is a groove for the liquid gasket application, apply the liquid gasket to the groove.
- As for the bolt holes, normally apply the liquid gasket inside the holes. If specified in the procedure, it should also be applied outside the holes.
- Within five minutes of liquid gasket application, install the mating component.
- If the liquid gasket protrudes, wipe it off immediately.
- Do not retighten after the installation.
- Wait 30 minutes or more after installation before refilling the engine with engine oil and engine coolant.

CAUTION:

If there are specific instructions in this manual, observe them.

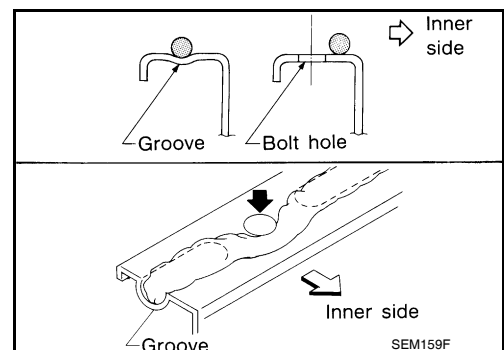

PREPARATION

< PREPARATION >

PREPARATION

PREPARATION

Special Service Tool

INFOID:000000004918816

The actual shapes of Kent-Moore tools may differ from those of special service tools illustrated here.

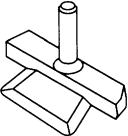
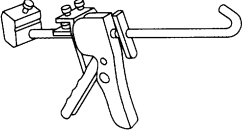
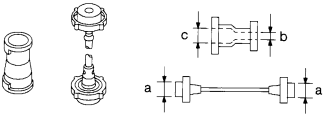
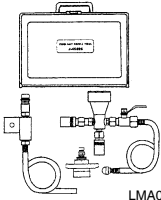
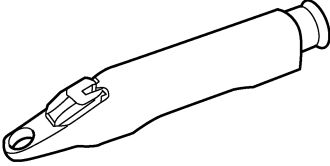
Tool number (Kent-Moore No.) Tool name	Description
KV10111100 (J-37228) Seal cutter	Removing steel oil pan and rear timing chain case  <p style="text-align: center;">NT046</p>
WS39930000 (—) Tube pressure	Pressing the tube of liquid gasket  <p style="text-align: center;">S-NT052</p>
EG17650301 (J-33984-A) Radiator cap tester adapter	Adapting radiator cap tester to radiator cap and radiator filler neck a: 28 (1.10) dia. b: 31.4 (1.236) dia. c: 41.3 (1.626) dia. Unit: mm (in)  <p style="text-align: center;">S-NT564</p>
KV991J0070 (J-45695) Coolant refill tool	For refilling engine cooling system  <p style="text-align: center;">LMA053</p>
KV991J0010 (J-23688) Engine coolant refractometer	Checking concentration of ethylene glycol in engine coolant  <p style="text-align: center;">WBIA0539E</p>

Commercial Service Tool

INFOID:000000004918817

PREPARATION

< PREPARATION >

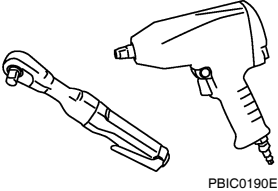
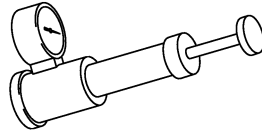
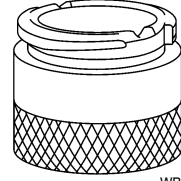
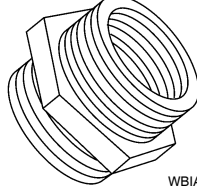
Tool name	Description
<p>Power tool</p>  <p>PBIC0190E</p>	<p>Loosening bolts and nuts</p>
<p>Radiator cap tester</p>  <p>PBIC1982E</p>	<p>Checking radiator and radiator cap</p>
<p>Coolant system tester adapter</p>  <p>WBIA0408E</p>	<p>Adapting radiator cap tester to reservoir filler neck</p>
<p>Coolant system tester adapter</p>  <p>WBIA0409E</p>	<p>Adapting radiator cap tester to reservoir cap</p>

A

CO

C

D

E

F

G

H

I

J

K

L

M

N

O

P

COOLING SYSTEM

< FUNCTION DIAGNOSIS >

FUNCTION DIAGNOSIS

COOLING SYSTEM

Cooling Circuit

INFOID:000000004918818

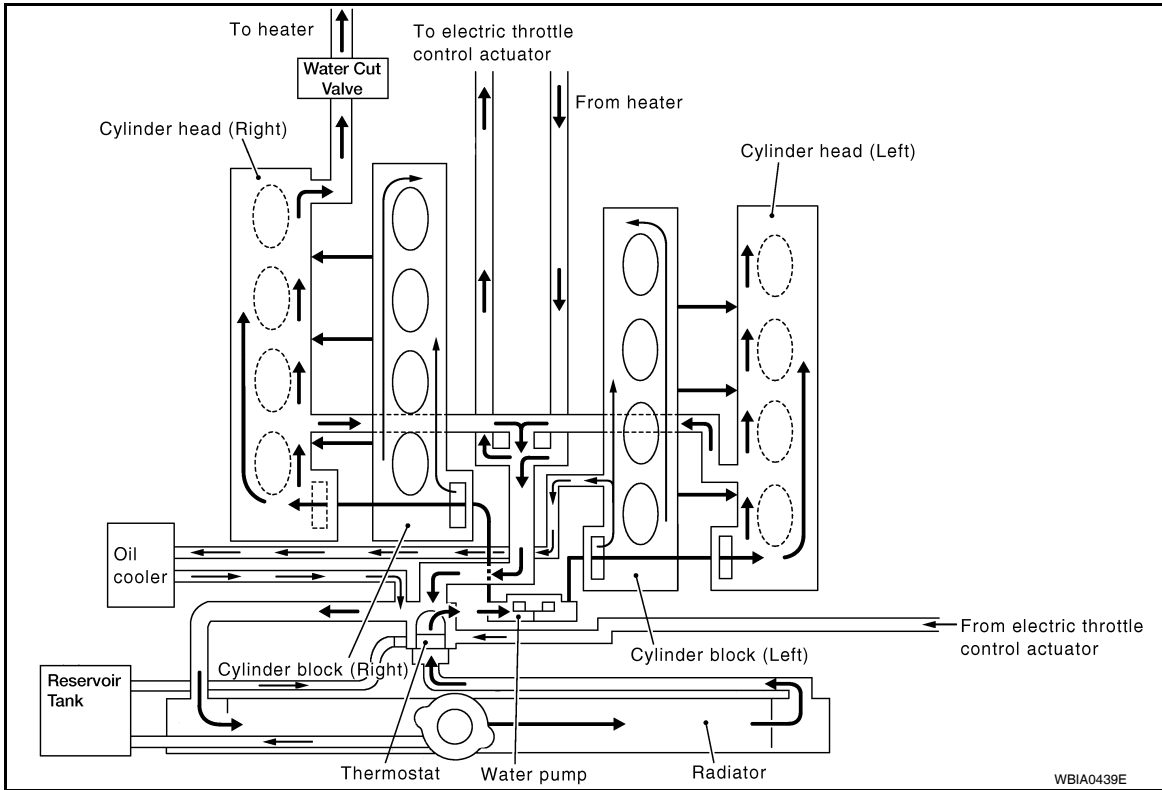

COOLING SYSTEM

< FUNCTION DIAGNOSIS >

Schematic

INFOID:000000004918819

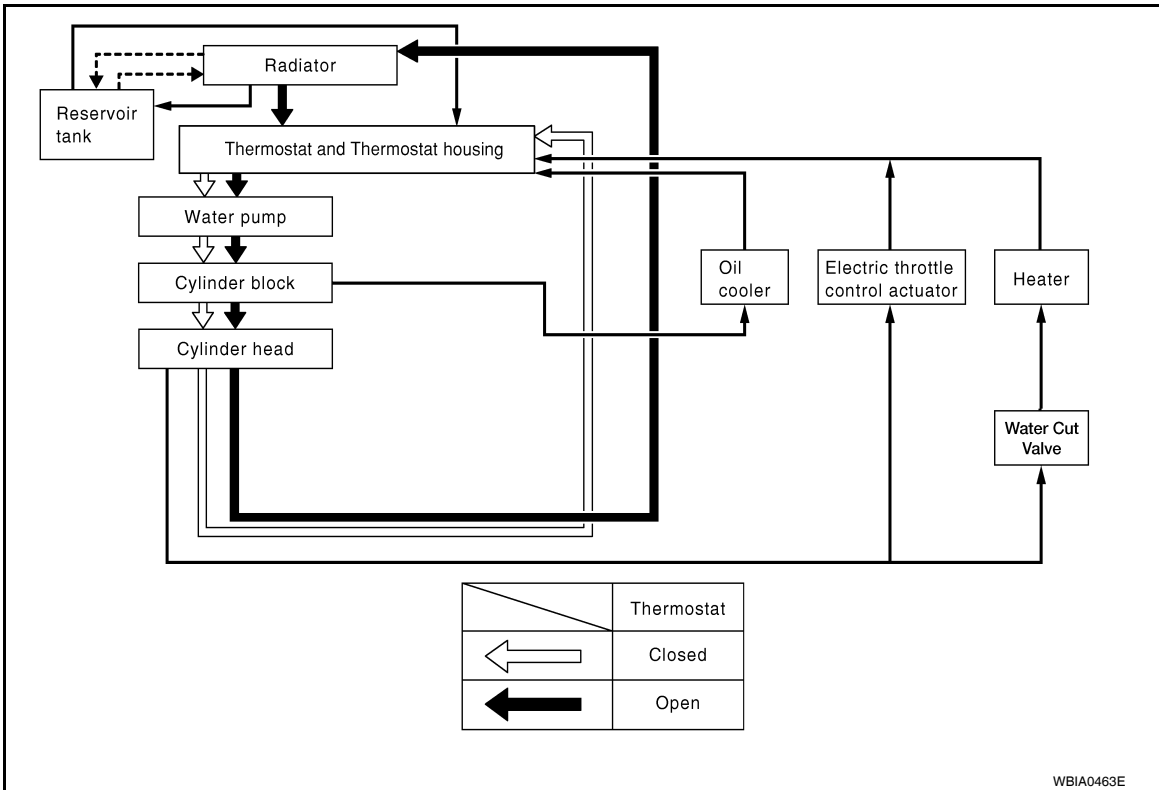

A

CO

C

D

E

F

G

H

I

J

K

L

M

N

O

P

OVERHEATING CAUSE ANALYSIS

< FUNCTION DIAGNOSIS >

OVERHEATING CAUSE ANALYSIS

Troubleshooting Chart

INFOID:000000004918820

	Symptom		Check items	
Cooling system parts malfunction	Poor heat transfer	Water pump malfunction	Worn or loose drive belt	—
		Thermostat stuck closed	Coolant circulation	
		Damaged fins	Dust contamination or paper clogging	
			Physical damage	
		Clogged radiator cooling tube	Excess foreign material (rust, dirt, sand, etc.)	
	Water cut valve malfunction	Excess foreign material (rust, dirt, sand, etc.), physical damage		
	Reduced air flow	Cooling fan does not operate	Fan assembly	—
		High resistance to fan rotation		
		Damaged fan blades		
	Damaged radiator shroud	—	Radiator shroud	—
	Improper engine coolant mixture ratio	—	Coolant viscosity	—
	Poor engine coolant quality	—	Engine coolant density	—
	Insufficient engine coolant	Engine coolant leaks	Cooling hose	Loose clamp
				Cracked hose
			Water pump	Poor sealing
Radiator cap			Loose	
			Poor sealing	
Radiator			O-ring for damage, deterioration or improper fitting	
		Cracked radiator tank		
Reservoir tank		Cracked radiator core		
Overflowing reservoir tank	Exhaust gas leaks into cooling system	Cracked reservoir tank		
		Cylinder head deterioration		
			Cylinder head gasket deterioration	

OVERHEATING CAUSE ANALYSIS

< FUNCTION DIAGNOSIS >

		Symptom		Check items			
Except cooling system parts malfunction	—	Overload on engine	Abusive driving	High engine rpm under no load	—	A	
				Driving in low gear for extended time		CO	
				Driving at extremely high speed		C	
					Powertrain system malfunction		D
					Installed improper size wheels and tires		E
					Dragging brakes		F
	Blocked or restricted air flow		Blocked radiator grille	Installed car brassiere	—	G	
			Blocked bumper	Mud contamination or paper clogging		H	
			Blocked radiator			I	
			Blocked condenser	Blocked air flow		J	
			Installed large fog lamp			K	
					L		
				M			
				N			
				O			
				P			

ENGINE COOLANT

< ON-VEHICLE MAINTENANCE >

ON-VEHICLE MAINTENANCE

ENGINE COOLANT

Inspection

INFOID:000000004918821

LEVEL CHECK

- Check if the engine coolant reservoir tank level is within MIN to MAX level when engine is cool.
- Adjust engine coolant level as necessary.

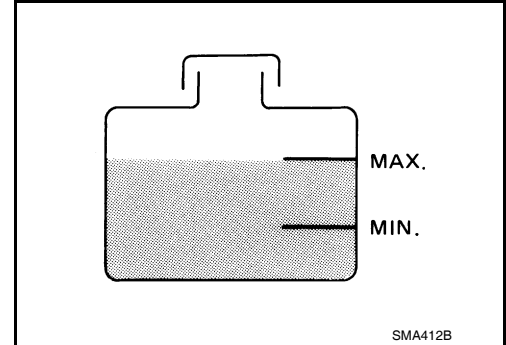

CHECKING COOLING SYSTEM FOR LEAKS

WARNING:

Never remove the radiator or reservoir cap when the engine is hot. Serious burns could occur from high-pressure engine coolant escaping from the radiator or reservoir.

- To check for leakage, apply pressure to the cooling system at the reservoir filler neck using suitable tool and Tool.

Tool number : EG17650301 (J-33984-A)

Leakage test pressure : 137 kPa (1.4 kg/cm², 20 psi)

CAUTION:

Higher pressure than specified may cause radiator damage.

NOTE:

In case that engine coolant decreases, replenish cooling system with engine coolant.

- If any concerns are found, repair or replace damaged parts.

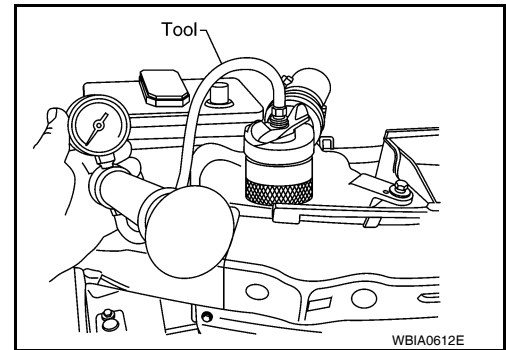

CHECKING RESERVOIR CAP

- Check reservoir cap relief pressure using suitable tool and Tool.

Tool number : EG17650301 (J-33984-A)

Standard : 95 - 125 kPa (0.97 - 1.28 kg/cm², 14 - 18 psi)

NOTE:

Apply engine coolant to the cap seal.

- Replace the reservoir cap if there is any damage in the negative-pressure valve, or if the open-valve pressure is outside of the limit.

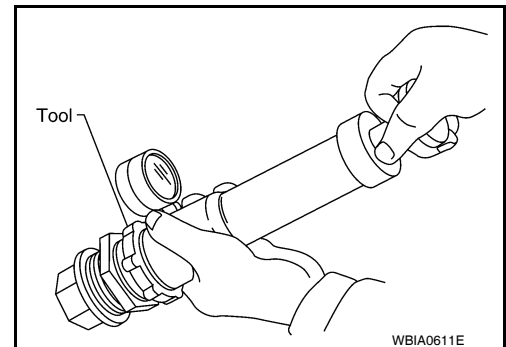

CHECKING RADIATOR CAP

ENGINE COOLANT

< ON-VEHICLE MAINTENANCE >

Inspect the radiator cap.

NOTE:

Thoroughly wipe out the radiator filler neck to remove any waxy residue or foreign material.

- Replace the cap if the metal plunger cannot be seen around the edge of the black rubber gasket.
- Replace the cap if deposits of waxy residue or other foreign material are on the black rubber gasket or the metal retainer.

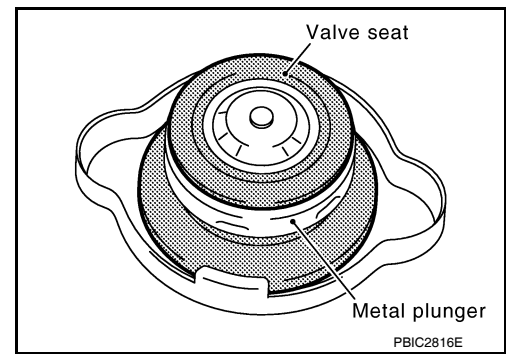

- Pull negative-pressure valve to open it and make sure that it closes completely when released.
- Make sure that there is no dirt or damage on the valve seat of radiator cap negative-pressure valve.
- Make sure that there are no unusualness in the opening and closing conditions of negative-pressure valve.

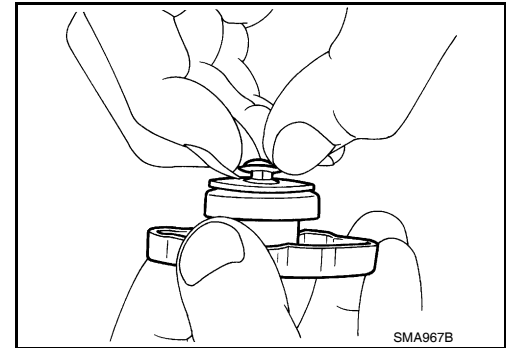

Changing Engine Coolant

INFOID:000000004918822

WARNING:

- To avoid being scalded, never change the coolant when the engine is hot.
- Wrap a thick cloth around the cap to carefully remove the cap. First, turn the cap a quarter of a turn to release any built-up pressure, then push down and turn the cap all the way to remove it.

DRAINING ENGINE COOLANT

1. Turn ignition switch ON and set temperature control lever all the way to HOT position or the highest temperature position. Wait 10 seconds and turn ignition switch OFF.
2. Remove the engine front undercover using power tool.
3. Open the radiator drain plug at the bottom of the radiator, and remove the radiator filler cap. This is the only step required when partially draining the cooling system (radiator only).

CAUTION:

Do not to allow the coolant to contact the drive belts.

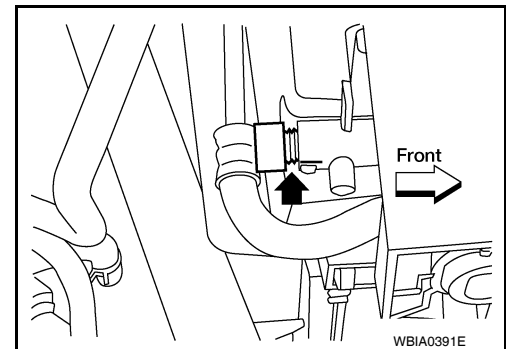

4. When draining all of the coolant in the system for engine removal or repair, it is necessary to drain the cylinder block. Remove the RH cylinder block drain plug to drain the right bank and the oil cooler hose to drain the left bank as shown.

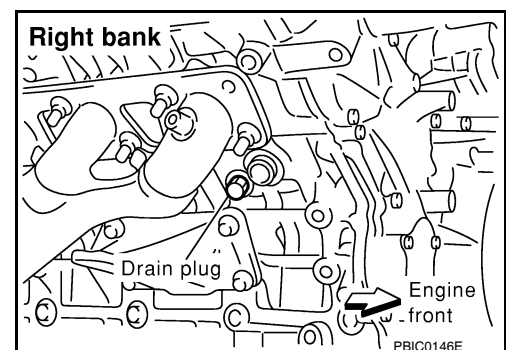

ENGINE COOLANT

< ON-VEHICLE MAINTENANCE >

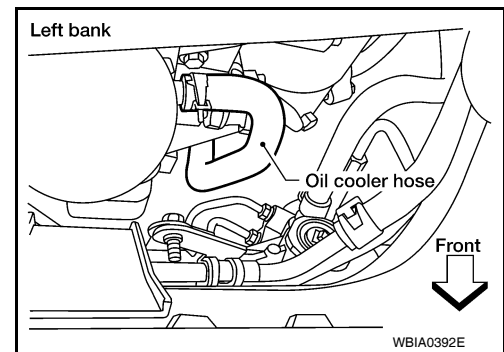

5. Remove the reservoir tank to drain the engine coolant, then clean the reservoir tank before installing it.
6. Check the drained coolant for contaminants such as rust, corrosion or discoloration. If the coolant is contaminated, flush the engine cooling system. Refer to [CO-11. "Changing Engine Coolant"](#).

REFILLING ENGINE COOLANT

1. Close the radiator drain plug. Install the reservoir tank, cylinder block drain plug, and the oil cooler hose, if removed for a total system drain or for engine removal or repair.
 - The radiator must be completely empty of coolant and water.
 - Apply sealant to the threads of the cylinder block drain plug. Use Genuine High Performance Thread Sealant or equivalent. Refer to [GI-15. "Recommended Chemical Products and Sealants"](#).

Radiator drain plug : Refer to [CO-15](#).

RH cylinder block drain plug : Refer to [EM-83](#).

2. Set the vehicle heater controls to the full HOT and heater ON position. Turn the vehicle ignition ON with the engine OFF as necessary to activate the heater mode.
3. Remove the vented reservoir cap and replace it with a non-vented reservoir cap before filling the cooling system.
4. Install the Tool by installing the radiator cap adapter onto the radiator neck opening. Then attach the gauge body assembly with the refill tube and the venturi assembly to the radiator cap adapter.

Tool number : KV991J0070 (J-45695)

5. Insert the refill hose into the coolant mixture container that is placed at floor level. Make sure the ball valve is in the closed position.
 - Use Genuine NISSAN Long Life Anti-freeze coolant or equivalent, mixed 50/50 with distilled water or demineralized water. Refer to [MA-19. "FOR NORTH AMERICA : Fluids and Lubricants"](#).

Cooling system capacity (with reservoir) : Refer to [MA-19. "FOR NORTH AMERICA : Fluids and Lubricants"](#).

6. Install an air hose to the venturi assembly, the air pressure must be within specification.

Compressed air supply pressure : 5.7 - 8.5 kPa (5.6 - 8.4 kg/cm², 80 - 120 psi)

CAUTION:

The compressed air supply must be equipped with an air dryer.

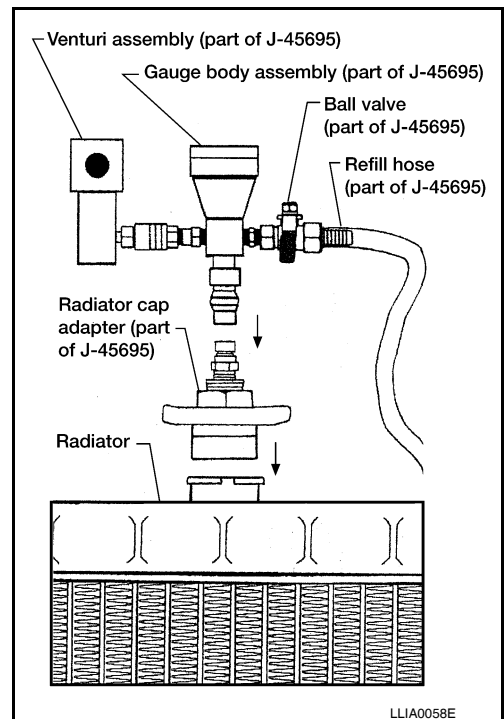

ENGINE COOLANT

< ON-VEHICLE MAINTENANCE >

- The vacuum gauge will begin to rise and there will be an audible hissing noise. During this process open the ball valve on the refill hose slightly. Coolant will be visible rising in the refill hose. Once the refill hose is full of coolant, close the ball valve. This will purge any air trapped in the refill hose.
- Continue to draw the vacuum until the gauge reaches 28 inches of vacuum. The gauge may not reach 28 inches in high altitude locations, refer to the vacuum specifications based on the altitude above sea level.

Altitude above sea level	Vacuum gauge reading
0 - 100 m (328 ft)	: 28 inches of vacuum
300 m (984 ft)	: 27 inches of vacuum
500 m (1,641 ft)	: 26 inches of vacuum
1,000 m (3,281 ft)	: 24 - 25 inches of vacuum

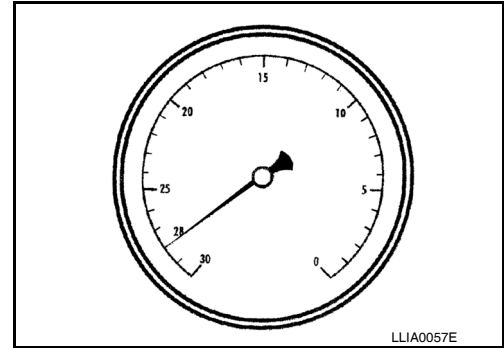

- When the vacuum gauge has reached the specified amount, disconnect the air hose and wait 20 seconds to see if the system loses any vacuum. If the vacuum level drops, perform any necessary repairs to the system and repeat steps 6 - 8 to bring the vacuum to the specified amount. Recheck for any leaks.
- Place the coolant container (with the refill hose inserted) at the same level as the top of the radiator. Then open the ball valve on the refill hose so the coolant will be drawn up to fill the cooling system. The cooling system is full when the vacuum gauge reads zero.

CAUTION:

Do not allow the coolant container to get too low when filling, to avoid air from being drawn into the cooling system.

- Remove the Tool from the radiator neck opening and install the radiator cap.
- Remove the non-vented reservoir cap.
- Fill the cooling system reservoir tank to the specified level. Run the engine to warm up the cooling system and top up the system as necessary before installing the vented reservoir cap.

FLUSHING COOLING SYSTEM

- Drain the water from the engine cooling system. Refer to [CO-11, "Changing Engine Coolant"](#).
- Fill the radiator and the reservoir tank (to the "MAX" line), with water. Reinstall the radiator cap and leave the vented reservoir cap off.
- Run the engine until it reaches normal operating temperature.
- Press the engine accelerator two or three times under no-load.
- Stop the engine and wait until it cools down.
- Drain the water from the engine cooling system. Refer to [CO-11, "Changing Engine Coolant"](#).
- Repeat steps 2 through 6 until clear water begins to drain from the radiator.

RADIATOR

< ON-VEHICLE MAINTENANCE >

RADIATOR

Checking Radiator

INFOID:000000004918823

Check radiator for mud or clogging. If necessary, clean radiator as follows.

CAUTION:

- **Be careful not to bend or damage the radiator fins.**
 - **When radiator is cleaned without removal, remove all surrounding parts such as cooling fan, radiator shroud and horns. Then tape the harness and electrical connectors to prevent water from entering.**
1. Apply water by hose to the back side of the radiator core vertically downward.
 2. Apply water again to all radiator core surfaces.
 3. Stop washing when dirt and debris no longer flow out from the radiator.
 4. Blow air into the back side of radiator core vertically downward.
 - Use compressed air lower than 490 kPa (5 kg/cm², 71 psi) and keep distance more than 30 cm (11.8 in).
 5. Blow air again into all the radiator core surfaces until no water sprays out.

RADIATOR

< ON-VEHICLE REPAIR >

ON-VEHICLE REPAIR

RADIATOR

Exploded View

INFOID:000000004918824

A

CO

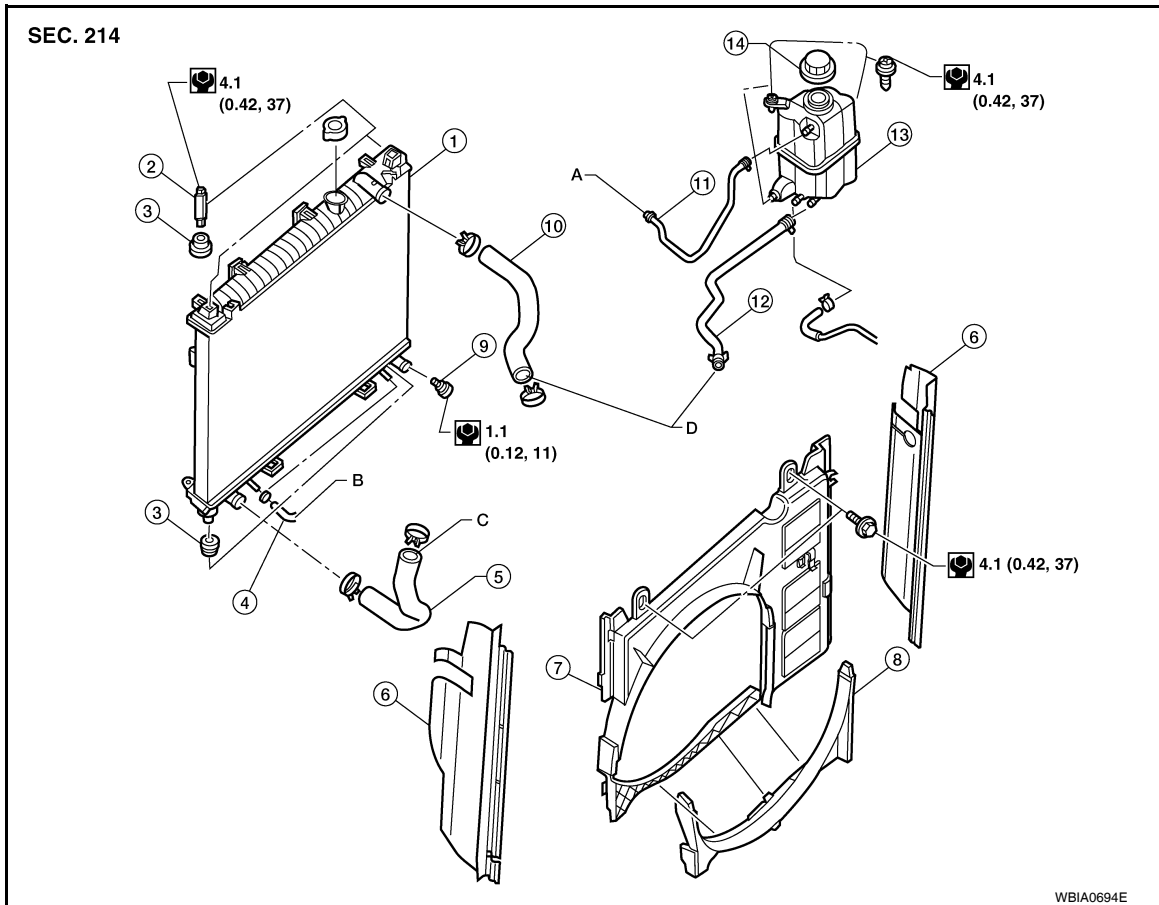

C

D

E

F

G

H

I

J

K

- | | | |
|----------------------------|----------------------------|--------------------------|
| 1. Radiator | 2. Bolt | 3. Mounting rubber |
| 4. A/T fluid cooler hose | 5. Radiator hose (lower) | 6. Flaps |
| 7. Radiator shroud (upper) | 8. Radiator shroud (lower) | 9. Drain plug |
| 10. Radiator hose (upper) | 11. Reservoir tank hose | 12. By-pass hose |
| 13. Reservoir tank | 14. Reservoir tank cap | A. To radiator fill neck |
| B. To A/T cooler tube | C. To water suction pipe | D. To thermostat housing |

L

M

Removal and Installation

INFOID:000000004918825

WARNING:

Never remove the radiator cap when the engine is hot. Serious burns could occur from high-pressure engine coolant escaping from the radiator.

REMOVAL

CAUTION:

Perform when the engine is cold.

1. Drain engine coolant from the radiator. Refer to [CO-11, "Changing Engine Coolant"](#).
2. Remove engine room cover. Refer to [EM-24, "Removal and Installation"](#).
3. Remove air cleaner and air duct assembly. Refer to [EM-25, "Removal and Installation"](#).
4. Disconnect A/T fluid cooler hoses.
 - Install blind plug to avoid leakage of A/T fluid.

N

O

P

RADIATOR

< ON-VEHICLE REPAIR >

5. Disconnect the radiator lower hose from the radiator.

CAUTION:

Do not allow coolant to contact drive belts.

6. Remove the lower radiator shroud.
 - Release the tabs, pull lower radiator shroud rearwards and down to remove.

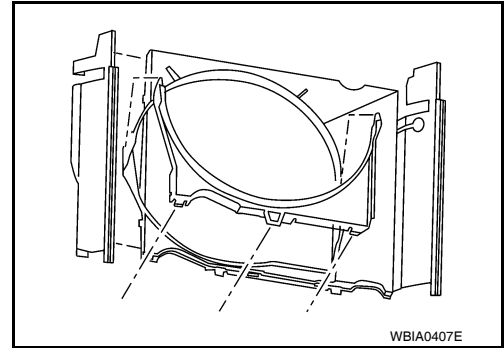

7. Disconnect the radiator upper hose and the coolant reservoir hose from the radiator.

CAUTION:

Do not allow coolant to contact drive belts.

8. Remove the radiator shroud upper bolts and remove the radiator shroud upper (A).

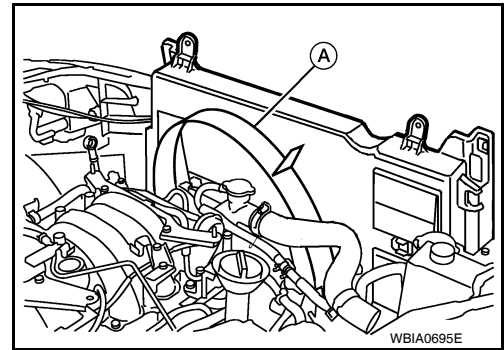

9. Remove the upper radiator mounting bolts and rubbers.

10. Remove the A/C condenser bolts and brackets.

NOTE:

Lift A/C condenser up and forward to remove from radiator.

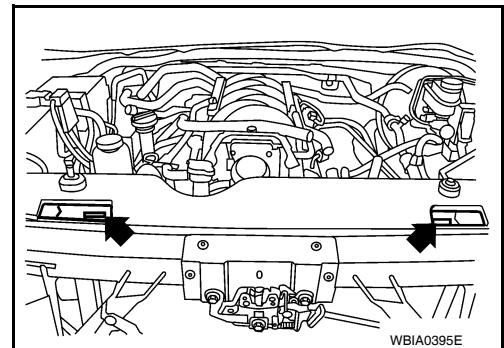

11. Remove A/T oil cooler bolts and oil cooler from radiator and position aside.

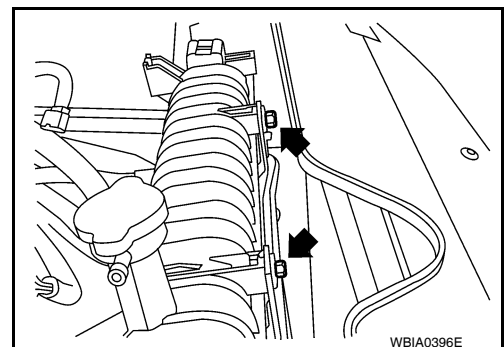

RADIATOR

< ON-VEHICLE REPAIR >

12. Lift up and remove the radiator.

CAUTION:

Do not damage or scratch air conditioner condenser, A/T oil cooler or radiator core when removing.

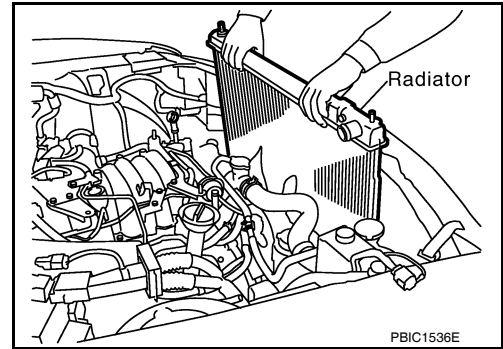

INSTALLATION

Installation is in the reverse order of removal.

- Refill A/T fluid. Refer to [TM-156, "Changing the A/T Fluid \(ATF\)"](#).
- Refill engine coolant. Refer to [CO-11, "Changing Engine Coolant"](#).

INSPECTION AFTER INSTALLATION

- Check for leaks of engine coolant. Refer to [CO-10, "Inspection"](#).
- Start and warm up the engine. Visually check for leaks of the engine coolant and A/T fluid.

A

CO

C

D

E

F

G

H

I

J

K

L

M

N

O

P

ENGINE COOLING FAN

< ON-VEHICLE REPAIR >

ENGINE COOLING FAN

Exploded View

INFOID:000000004918826

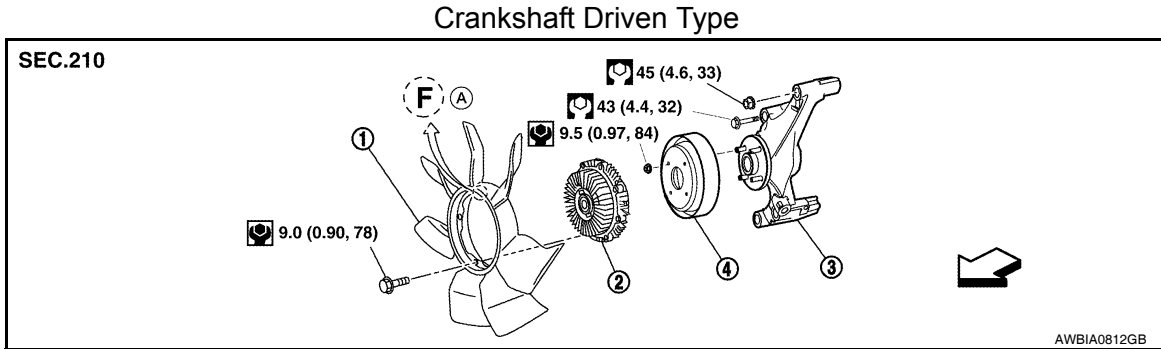

- | | | |
|-----------------------|-----------------|----------------|
| 1. Cooling fan | 2. Fan coupling | 3. Fan bracket |
| 4. Cooling fan pulley | A. Front mark | ⇐ Engine front |

Removal and Installation (Crankshaft Driven Type)

INFOID:000000004918827

REMOVAL

1. Partially drain engine coolant from the radiator. Refer to [CO-11, "Changing Engine Coolant"](#).
2. Remove the lower and upper radiator shrouds. Refer to [CO-15, "Exploded View"](#).
3. Remove the drive belt. Refer to [EM-13, "Removal and Installation"](#).
4. Remove the cooling fan.
5. Remove the cooling fan pulley and fan bracket, if necessary.

INSPECTION AFTER REMOVAL

Fan Coupling

- Inspect fan coupling for oil leakage and bimetal conditions.
- If there are any unusual concerns, replace the fan coupling.

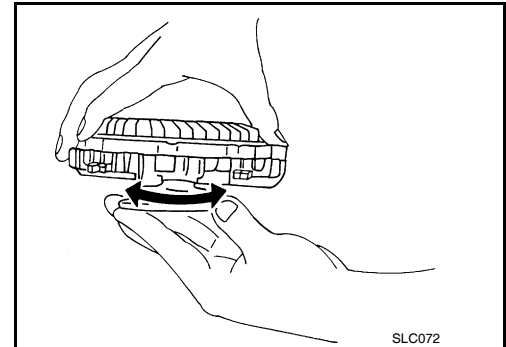

Fan Bracket

- Visually check that there is no significant looseness in the fan bracket shaft, and that it turns smoothly by hand.
- If there are any unusual concerns, replace the fan bracket.

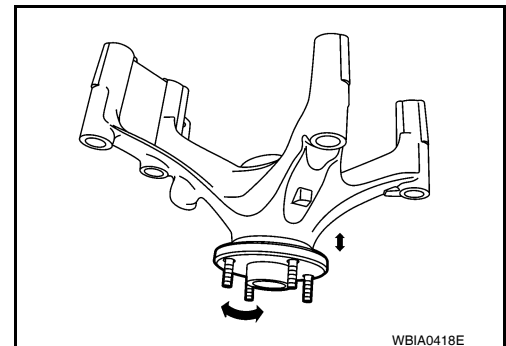

Cooling Fan Pulley

- Inspect cooling fan pulley.
- If there are any unusual concerns, replace the cooling fan pulley.

ENGINE COOLING FAN

< ON-VEHICLE REPAIR >

INSTALLATION

Installation is in the reverse order of removal.

- Install cooling fan with its front mark "F" facing front of vehicle.
- Refill engine coolant. Refer to [CO-11, "Changing Engine Coolant"](#).

INSPECTION AFTER INSTALLATION

- Check for leaks of the engine coolant. Refer to [CO-10, "Inspection"](#).
- Start and warm up the engine. Visually make sure that there are no leaks of the engine coolant.

Removal and Installation (Motor Driven Type)

INFOID:000000004918828

REMOVAL

1. Remove the front grille. Refer to [EXT-17, "Removal and Installation"](#).
2. Remove the front bumper fascia. Refer to [EXT-13, "Removal and Installation"](#).
3. Disconnect harness connector (A) from fan motor.
4. Remove the bolt and remove the fan grille and motor assembly.

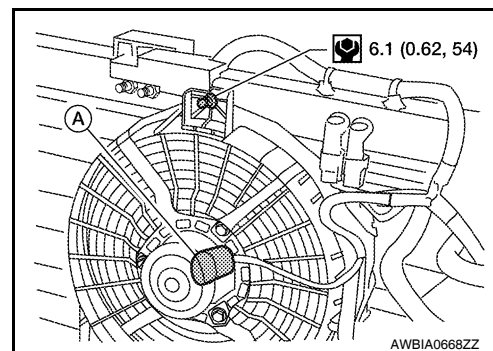

INSTALLATION

Installation is in the reverse order of removal.

- Cooling fan is controlled by ECM. For details, refer to [EC-312, "Diagnosis Procedure"](#).

WATER PUMP

< ON-VEHICLE REPAIR >

WATER PUMP

Exploded View

INFOID:000000004918829

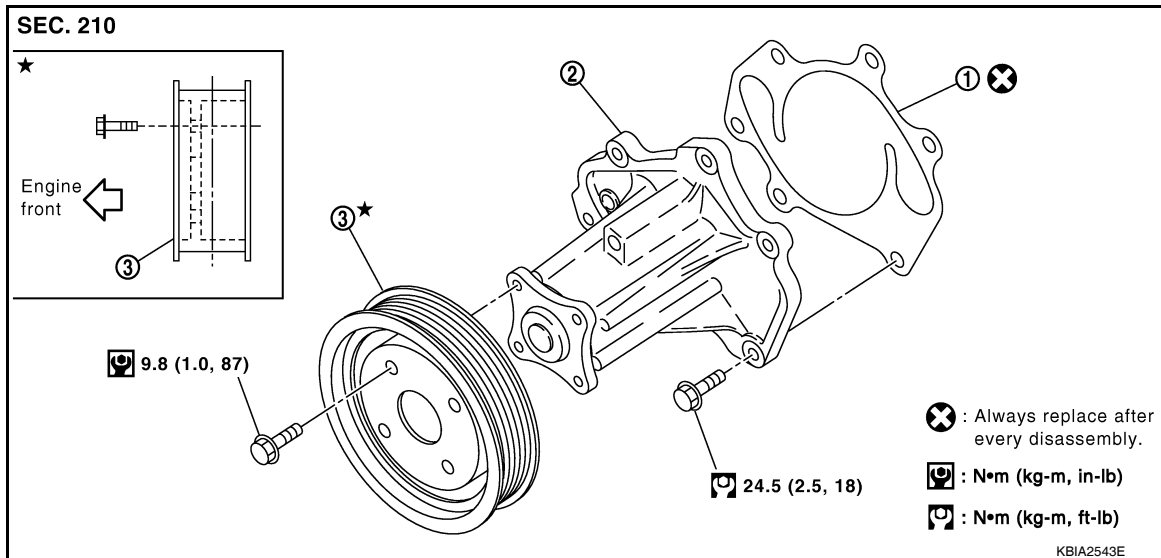

1. Gasket

2. Water pump

3. Water pump pulley

Removal and Installation

INFOID:000000004918830

CAUTION:

- When removing water pump, be careful not to get engine coolant on drive belt.
- Water pump cannot be disassembled and should be replaced as a unit.

REMOVAL

1. Drain engine coolant from the radiator. Refer to [CO-11, "Changing Engine Coolant"](#).

CAUTION:

Perform when the engine is cold.

2. Remove the engine cooling fan (crankshaft driven type). Refer to [CO-18, "Removal and Installation \(Crankshaft Driven Type\)"](#).
3. Remove lower radiator hose.
4. Remove the water pump pulley.
5. Remove the water pump.
 - Engine coolant will leak from the cylinder block, so have a receptacle ready below.

CAUTION:

Handle water pump vane so that it does not contact any other parts.

INSPECTION AFTER REMOVAL

- Visually check that there is no significant dirt or rust on the water pump body and vane.
- Make sure there is no looseness in the vane shaft, and that it turns smoothly when rotated by hand.
- Replace the water pump assembly, if necessary.

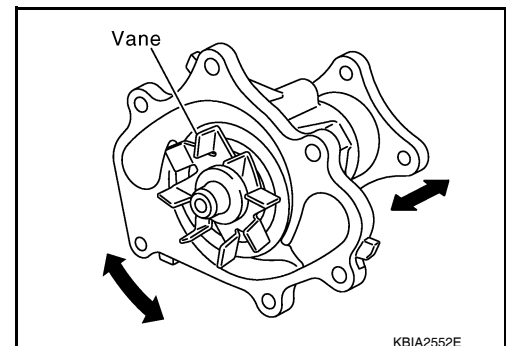

INSTALLATION

Installation is in the reverse order of removal.

WATER PUMP

< ON-VEHICLE REPAIR >

- After installation bleed the air from the cooling system. Refer to [CO-11, "Changing Engine Coolant"](#).

INSPECTION AFTER INSTALLATION

- Check for leaks of engine coolant. Refer to [CO-10, "Inspection"](#).
- Start and warm up engine. Visually check for leaks of the engine coolant.

A

CO

C

D

E

F

G

H

I

J

K

L

M

N

O

P

THERMOSTAT AND WATER PIPING

< ON-VEHICLE REPAIR >

THERMOSTAT AND WATER PIPING

Exploded View

INFOID:000000004918831

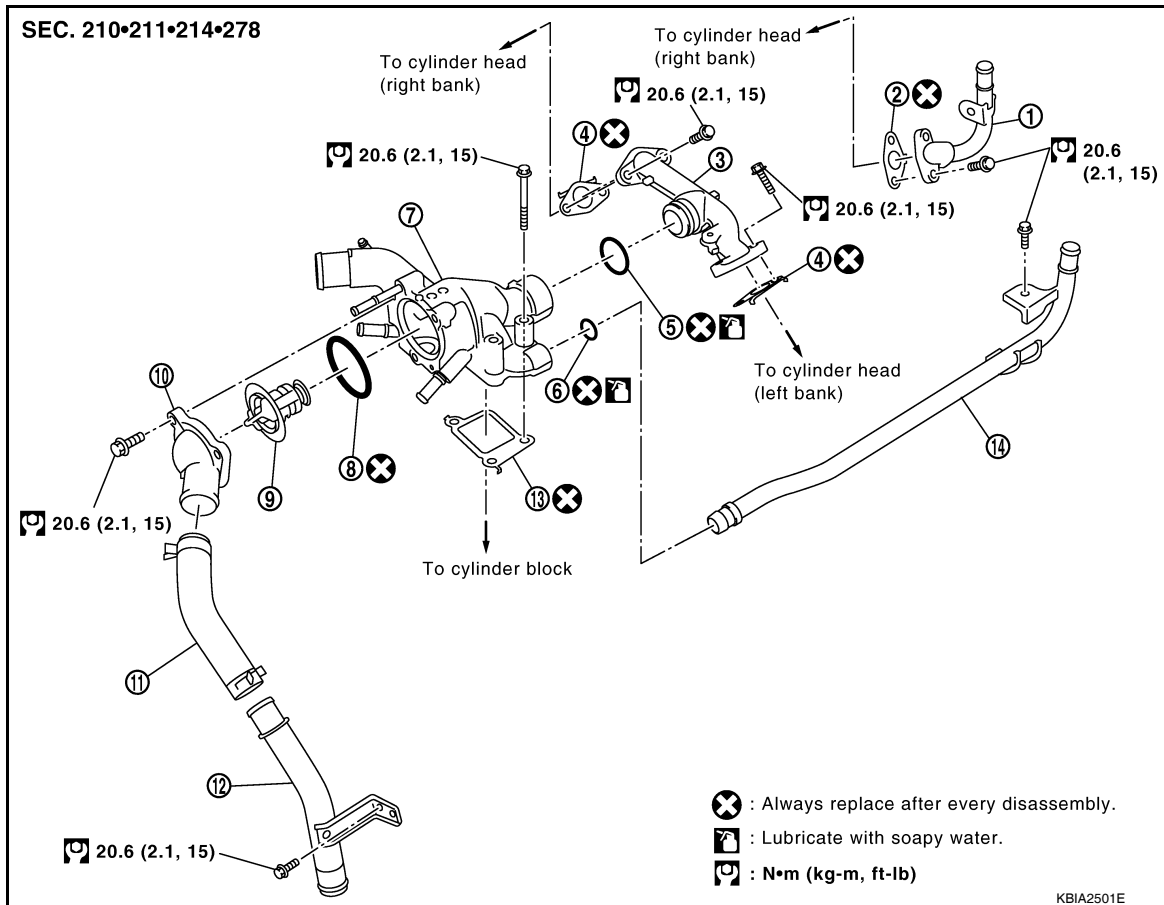

- | | | |
|-----------------------|------------------------|------------------------|
| 1. Heater pipe | 2. Gasket | 3. Water outlet |
| 4. Gasket | 5. O-ring | 6. O-ring |
| 7. Thermostat housing | 8. Rubber ring | 9. Thermostat |
| 10. Water inlet | 11. Water suction hose | 12. Water suction pipe |
| 13. Gasket | 14. Heater pipe | |

Removal and Installation

INFOID:000000004918832

REMOVAL

Removal of Thermostat

1. Partially drain engine coolant from the radiator. Refer to [CO-11, "Changing Engine Coolant"](#).

CAUTION:

Perform when engine is cold.

2. Disconnect the water suction hose from the water inlet.
3. Remove the water inlet, thermostat and rubber ring.

Removal of Thermostat Housing, Water Outlet and Heater Pipe

1. Disconnect the negative battery terminal. Refer to [PG-76, "Removal and Installation"](#).
2. Remove the intake manifold. Refer to [EM-26, "Removal and Installation"](#).
 - Remove upper radiator hose.
 - Remove water hoses.
3. Remove the thermostat housing, water outlet and heater pipe.

THERMOSTAT AND WATER PIPING

< ON-VEHICLE REPAIR >

Removal of Water Cut Valve

- Partially drain the engine coolant from the radiator. Refer to [CO-11, "Changing Engine Coolant"](#).

CAUTION:

Perform when the engine is cold.

- Disconnect the water cut valve connector.
- Disconnect the water hoses from the water cut valve.
- Remove the water cut valve.

INSPECTION AFTER REMOVAL

- Place a thread so that it is caught in the valve of the thermostat. Immerse fully in a container filled with water. Heat while stirring.
- The valve opening temperature is the temperature at which the valve opens and falls from the thread.
- Continue heating. Check the full-open lift amount.
- After checking the full-open lift amount, lower the water temperature and check the valve closing temperature.

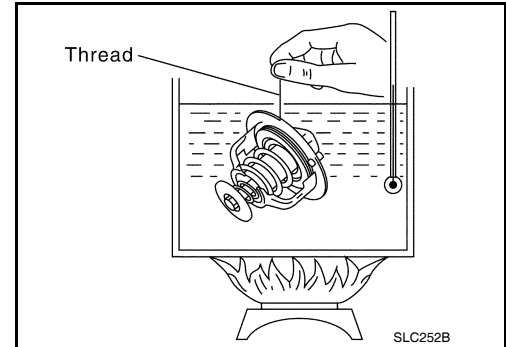

Standard values:

	Thermostat
Valve opening temperature	80 - 84°C (176 - 183° F)
Full-open lift amount	More than 10 mm/ 95°C (0.39 in/ 203°F)
Valve closing temperature	77°C (171°F) or higher

INSTALLATION

Installation is in the reverse order of removal.

Installation of Thermostat

- Install the thermostat with the whole circumference of each flange part fit securely inside the rubber ring as shown.
- Install the thermostat with the jiggle valve facing upwards.

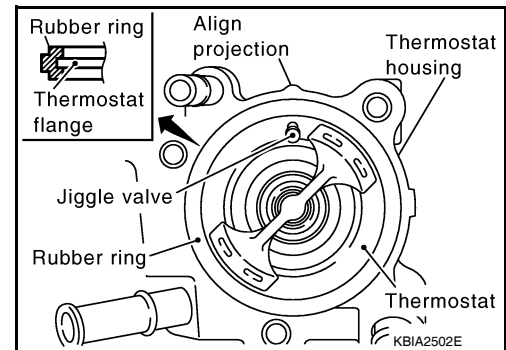

Installation of Water Outlet Pipe and Heater Pipe

First apply a neutral detergent to the O-rings, then quickly insert the insertion parts of the water outlet pipe and heater pipe into the installation holes.

INSPECTION AFTER INSTALLATION

- Check for leaks of the engine coolant. Refer to [CO-10, "Inspection"](#).
- Start and warm up the engine. Visually check for leaks of the engine coolant.

SERVICE DATA AND SPECIFICATIONS (SDS)

< SERVICE DATA AND SPECIFICATIONS (SDS)

SERVICE DATA AND SPECIFICATIONS (SDS)

SERVICE DATA AND SPECIFICATIONS (SDS)

Standard and Limit

INFOID:000000004918833

ENGINE COOLANT CAPACITY (APPROXIMATE)

Unit: ℓ (US qt, Imp qt)

Engine coolant capacity with reservoir ("MAX" level)	14.4 (15 1/4, 12 5/8)
--	-----------------------

THERMOSTAT

Valve opening temperature	80 - 84°C (176 - 183°F)
Maximum valve lift	More than 10 mm/95°C (0.39 in/203°F)
Valve closing temperature	77°C (171°F) or higher

RADIATOR

Unit: kPa (kg/cm², psi)

Reservoir cap relief pressure	Standard	95 - 125 (0.97- 1.28, 14 - 18)
Leakage test pressure		137 (1.4, 20)