

MWI

SECTION

METER, WARNING LAMP & INDICATOR

A
B
C
D
E
F
G
H
I
J
K
L
M
N
O
P

CONTENTS

BASIC INSPECTION	4	FUEL GAUGE : Component Description	13
DIAGNOSIS AND REPAIR WORKFLOW	4	ENGINE OIL PRESSURE GAUGE	13
Work Flow	4	ENGINE OIL PRESSURE GAUGE : System Dia-	13
FUNCTION DIAGNOSIS	5	gram	13
METER SYSTEM	5	ENGINE OIL PRESSURE GAUGE : System De-	13
METER SYSTEM	5	scription	13
METER SYSTEM : System Diagram	5	ENGINE OIL PRESSURE GAUGE : Component	14
METER SYSTEM : System Description	5	Parts Location	14
METER SYSTEM : Arrangement of Combination		ENGINE OIL PRESSURE GAUGE : Component	14
Meter	6	Description	14
METER SYSTEM : Component Parts Location	7	A/T OIL TEMPERATURE GAUGE	14
METER SYSTEM : Component Description	7	A/T OIL TEMPERATURE GAUGE : System Dia-	15
SPEEDOMETER	8	gram	15
SPEEDOMETER : System Diagram	8	A/T OIL TEMPERATURE GAUGE : System De-	15
SPEEDOMETER : System Description	8	scription	15
SPEEDOMETER : Component Parts Location	9	A/T OIL TEMPERATURE GAUGE : Component	15
SPEEDOMETER : Component Description	9	Parts Location	15
TACHOMETER	9	A/T OIL TEMPERATURE GAUGE : Component	16
TACHOMETER : System Diagram	9	Description	16
TACHOMETER : System Description	10	VOLTAGE GAUGE	16
TACHOMETER : Component Parts Location	10	VOLTAGE GAUGE : System Diagram	16
TACHOMETER : Component Description	10	VOLTAGE GAUGE : System Description	16
ENGINE COOLANT TEMPERATURE GAUGE	10	VOLTAGE GAUGE : Component Parts Location	16
ENGINE COOLANT TEMPERATURE GAUGE :		VOLTAGE GAUGE : Component Description	17
System Diagram	11	ODO/TRIP METER	17
ENGINE COOLANT TEMPERATURE GAUGE :		ODO/TRIP METER : System Diagram	17
System Description	11	ODO/TRIP METER : System Description	17
ENGINE COOLANT TEMPERATURE GAUGE :		ODO/TRIP METER : Component Parts Location	18
Component Parts Location	11	ODO/TRIP METER : Component Description	18
ENGINE COOLANT TEMPERATURE GAUGE :		SHIFT POSITION INDICATOR	18
Component Description	12	SHIFT POSITION INDICATOR : System Diagram	18
FUEL GAUGE	12	SHIFT POSITION INDICATOR : System Descrip-	19
FUEL GAUGE : System Diagram	12	tion	19
FUEL GAUGE : System Description	12	SHIFT POSITION INDICATOR : Component	19
FUEL GAUGE : Component Parts Location	12	Parts Location	19
		SHIFT POSITION INDICATOR : Component De-	19
		scription	19

MWI

WARNING LAMPS/INDICATOR LAMPS	19	PARKING BRAKE SWITCH SIGNAL CIRCUIT	39
WARNING LAMPS/INDICATOR LAMPS : System Diagram	20	Description	39
WARNING LAMPS/INDICATOR LAMPS : System Description	20	Component Function Check	39
WARNING LAMPS/INDICATOR LAMPS : Component Parts Location	20	Diagnosis Procedure	39
WARNING LAMPS/INDICATOR LAMPS : Component Description	21	Component Inspection	39
INFORMATION DISPLAY	21	WASHER LEVEL SWITCH SIGNAL CIRCUIT..	40
INFORMATION DISPLAY : System Diagram	21	Description	40
INFORMATION DISPLAY : System Description ...	21	Diagnosis Procedure	40
INFORMATION DISPLAY : Component Parts Location	22	Component Inspection	40
INFORMATION DISPLAY : Component Description	22	COMPASS	41
COMPASS	24	Wiring Diagram	41
Description	24	ECU DIAGNOSIS	43
DIAGNOSIS SYSTEM (METER)	26	COMBINATION METER	43
Diagnosis Description	26	Reference Value	43
CONSULT-III Function (METER/M&A)	27	Wiring Diagram	45
COMPONENT DIAGNOSIS	30	Fail Safe	61
DTC U1000 CAN COMMUNICATION	30	DTC Index	62
DTC Logic	30	BCM (BODY CONTROL MODULE)	64
Diagnosis Procedure	30	Reference Value	64
DTC B2205 VEHICLE SPEED CIRCUIT	31	Terminal Layout	67
Description	31	Physical Values	67
DTC Logic	31	Wiring Diagram	73
Diagnosis Procedure	31	Fail Safe	77
POWER SUPPLY AND GROUND CIRCUIT	32	DTC Inspection Priority Chart	78
COMBINATION METER	32	DTC Index	78
COMBINATION METER : Diagnosis Procedure ...	32	IPDM E/R (INTELLIGENT POWER DISTRIBUTION MODULE ENGINE ROOM)	80
BCM (BODY CONTROL MODULE)	33	Reference Value	80
BCM (BODY CONTROL MODULE) : Diagnosis Procedure	33	Terminal Layout	81
IPDM E/R (INTELLIGENT POWER DISTRIBUTION MODULE ENGINE ROOM)	34	Physical Values	82
IPDM E/R (INTELLIGENT POWER DISTRIBUTION MODULE ENGINE ROOM) : Diagnosis Procedure	34	Wiring Diagram	86
FUEL LEVEL SENSOR SIGNAL CIRCUIT	36	Fail Safe	89
Description	36	DTC Index	91
Component Function Check	36	SYMPTOM DIAGNOSIS	92
Diagnosis Procedure	36	THE FUEL GAUGE POINTER DOES NOT MOVE	92
Component Inspection	37	Description	92
OIL PRESSURE SWITCH SIGNAL CIRCUIT ...	38	Diagnosis Procedure	92
Description	38	THE FUEL GAUGE POINTER DOES NOT MOVE TO "F" WHEN REFUELING	93
Component Function Check	38	Description	93
Diagnosis Procedure	38	Diagnosis Procedure	93
Component Inspection	38	THE OIL PRESSURE WARNING LAMP DOES NOT TURN ON	94
PARKING BRAKE SWITCH SIGNAL CIRCUIT	39	Description	94
Description	39	Diagnosis Procedure	94
Component Function Check	39	THE OIL PRESSURE WARNING LAMP DOES NOT TURN OFF	95
Diagnosis Procedure	39	Description	95
Component Inspection	39		

Diagnosis Procedure	95	THE LIFTGATE GLASS OPEN WARNING CONTINUES DISPLAYING, OR DOES NOT DISPLAY	102	A
THE PARKING BRAKE RELEASE WARNING CONTINUES DISPLAYING, OR DOES NOT DISPLAY	96	Description	102	B
Description	96	Diagnosis Procedure	102	
Diagnosis Procedure	96	NORMAL OPERATING CONDITION	103	
THE LOW WASHER FLUID WARNING CONTINUES DISPLAYING, or DOES NOT DISPLAY	97	COMPASS	103	C
Description	97	COMPASS : Description	103	
Diagnosis Procedure	97	PRECAUTION	104	D
THE DOOR OPEN WARNING CONTINUES DISPLAYING, OR DOES NOT DISPLAY	98	PRECAUTIONS	104	
Description	98	Precaution for Supplemental Restraint System (SRS) "AIR BAG" and "SEAT BELT PRE-TENSIONER"	104	E
Diagnosis Procedure	98	Precaution Necessary for Steering Wheel Rotation After Battery Disconnect	104	F
THE LIFTGATE OPEN WARNING CONTINUES DISPLAYING, OR DOES NOT DISPLAY.	100	ON-VEHICLE REPAIR	106	
Description	100	COMBINATION METER	106	G
Diagnosis Procedure	100	Removal and Installation	106	

MWI

DIAGNOSIS AND REPAIR WORKFLOW

< BASIC INSPECTION >

BASIC INSPECTION

DIAGNOSIS AND REPAIR WORKFLOW

Work Flow

INFOID:000000004918002

DETAILED FLOW

1.CONFIRM SYMPTOM

Confirm symptom or customer complaint.

>> GO TO 2

2.CHECK SELF-DIAGNOSIS OPERATION OF COMBINATION METER

Perform self-diagnosis of combination meter. Refer to [MWI-26. "Diagnosis Description"](#).

Does self-diagnosis mode operate?

YES >> GO TO 3

NO >> Check power supply and ground circuit of combination meter. Refer to [MWI-32. "COMBINATION METER : Diagnosis Procedure"](#). Then, GO TO 4

3.CHECK COMBINATION METER (CONSULT-III)

Select "METER/M&A" on CONSULT-III and perform "SELF-DIAGNOSIS" of combination meter. Refer to [MWI-27. "CONSULT-III Function \(METER/M&A\)"](#).

Self-diagnostic results content

No malfunction detected>>Repair or replace the cause of symptom. Then, GO TO 4

Malfunction detected>>Refer to [MWI-62. "DTC Index"](#). Then, GO TO 4

4.CONFIRM OPERATION

Does the combination meter operate normally?

YES or NO

YES >> Inspection End.

NO >> GO TO 1

METER SYSTEM

< FUNCTION DIAGNOSIS >

FUNCTION DIAGNOSIS

METER SYSTEM

METER SYSTEM

METER SYSTEM : System Diagram

INFOID:000000004918003

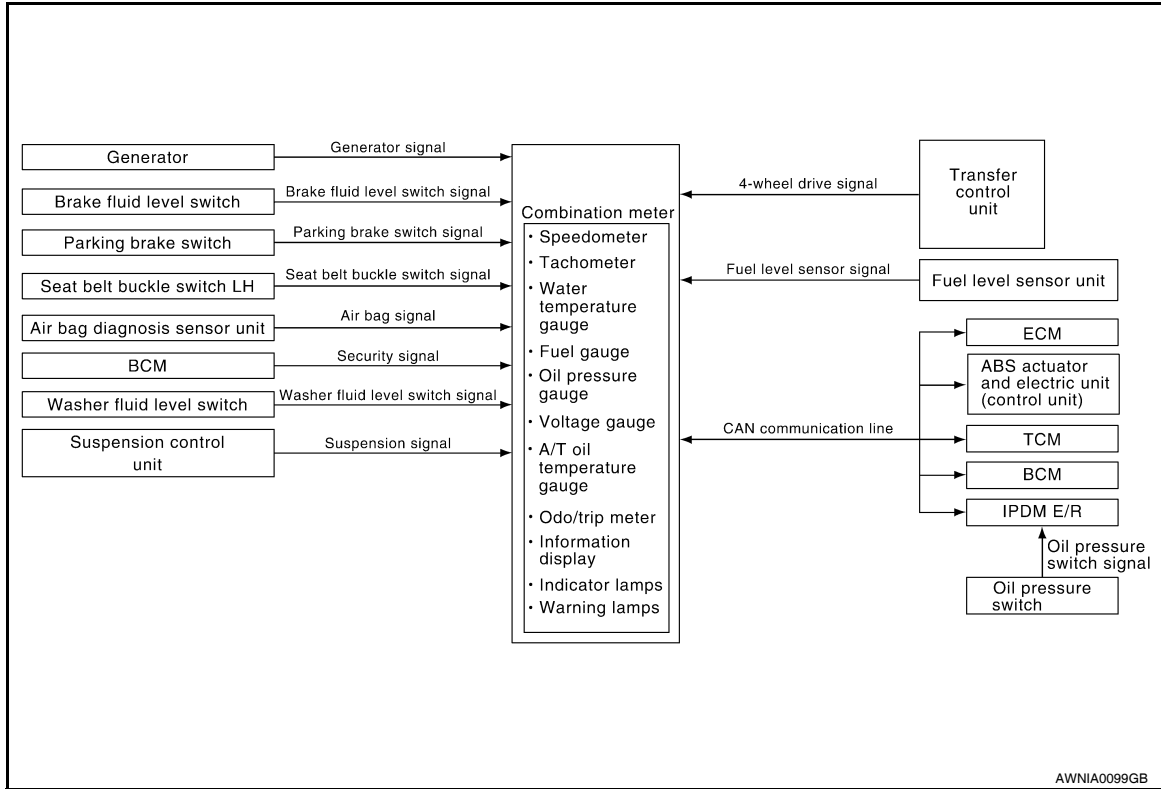

METER SYSTEM : System Description

INFOID:000000004918004

COMBINATION METER

- Speedometer, odo/trip meter, tachometer, fuel gauge, engine coolant temperature gauge, engine oil pressure gauge, voltage gauge, A/T oil temperature gauge and information display are controlled by the unified meter control unit, which is built into the combination meter.
- Warning and indicator lamps are controlled by the unified meter control unit and by components connected directly to the combination meter.
- Digital meter is adopted for odo/trip meter.*
*The record of the odometer is kept even if the battery cable is disconnected. The record of the trip meter is erased when the battery cable is disconnected.
- Odo/trip meter segments can be checked in diagnosis mode.
- Meter/gauge can be checked in diagnosis mode.

MWI

METER SYSTEM

< FUNCTION DIAGNOSIS >

METER SYSTEM : Arrangement of Combination Meter

INFOID:000000004918005

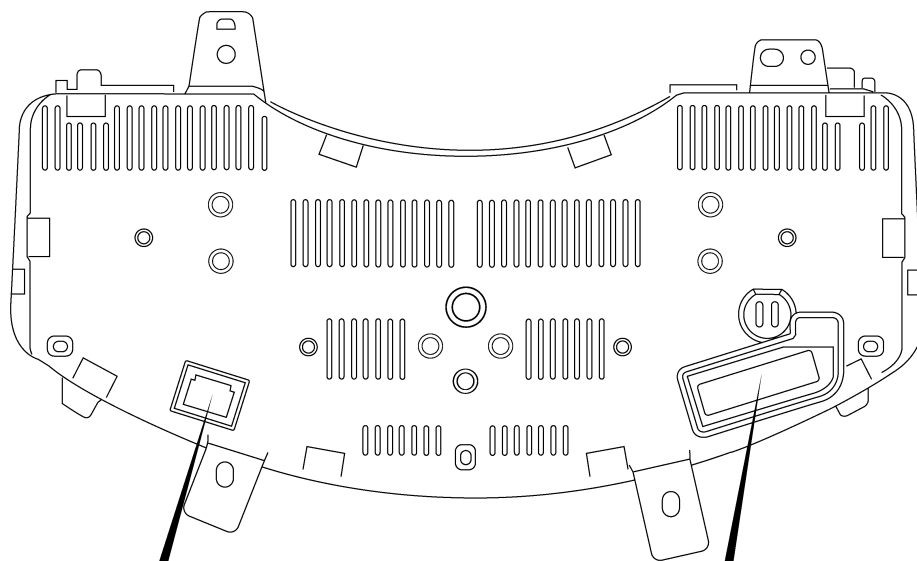
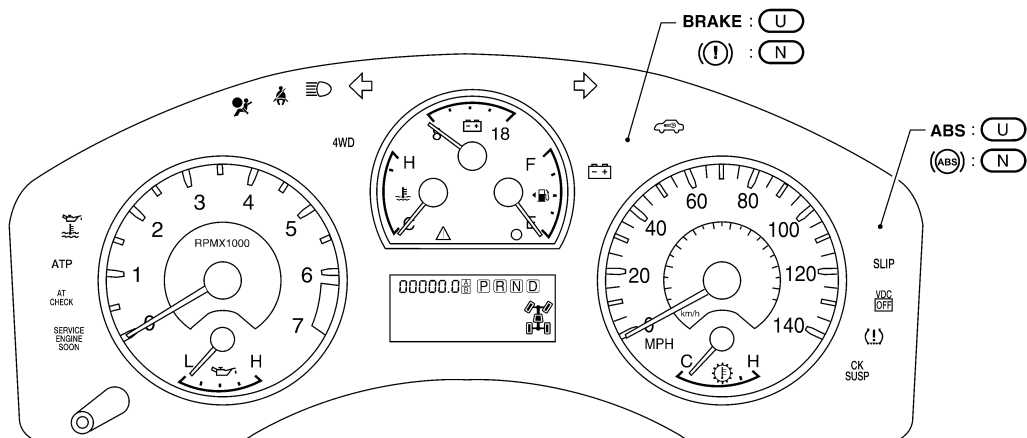

(N) : CANADA
(U) : USA

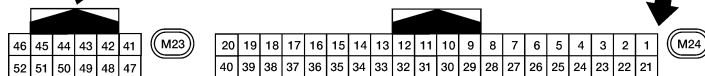

AWNIA0100GB

METER SYSTEM

< FUNCTION DIAGNOSIS >

METER SYSTEM : Component Parts Location

INFOID:000000004918006

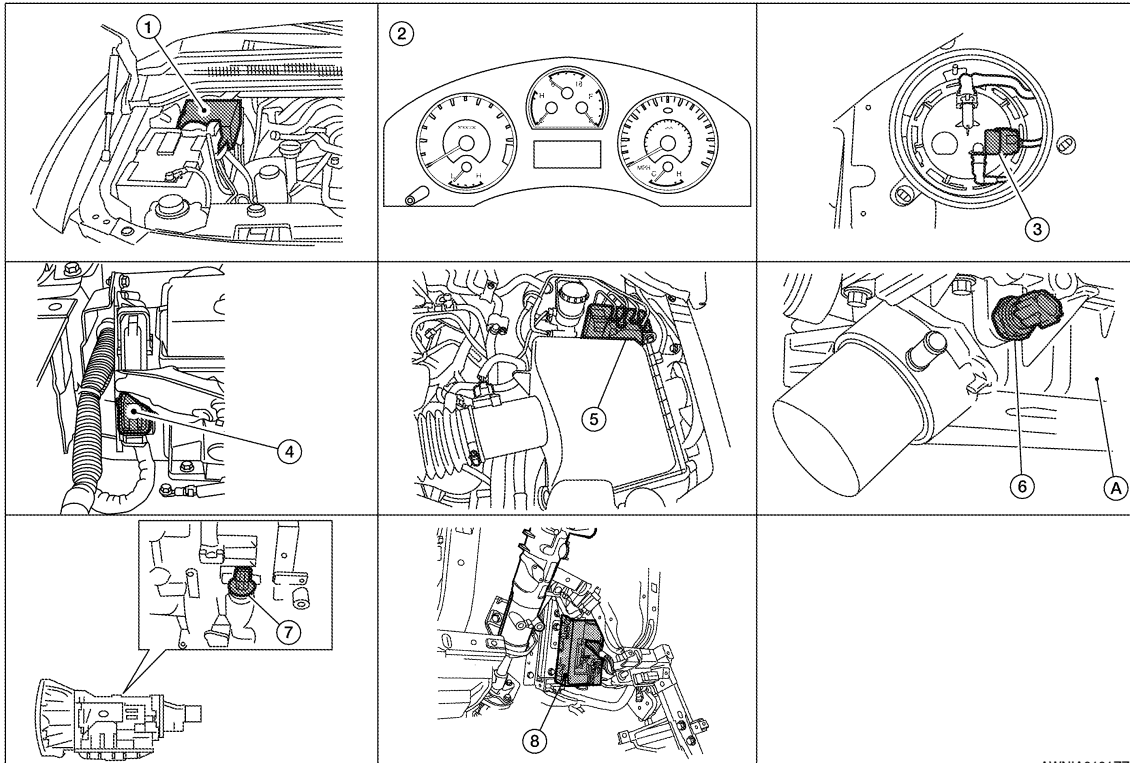

AWNIA0101ZZ

- | | | |
|--|---|---|
| 1. IPDM E/R E122, E124 | 2. Combination meter M23, M24 | 3. Fuel level sensor unit and fuel pump C5 |
| 4. ECM E16 (view with battery removed) | 5. ABS actuator and electric unit (control unit) E125 | 6. Oil pressure switch F4
A: Oil pan (upper) |
| 7. A/T assembly F9 | 8. BCM M18, M19 (view with instrument lower panel LH removed) | |

METER SYSTEM : Component Description

INFOID:000000004918007

Unit	Description
Combination meter	<p>Controls the following with the signals received from each unit via CAN communication and the signals from switches and sensors.</p> <ul style="list-style-type: none"> • Speedometer • Engine coolant temperature gauge • Engine oil pressure gauge • Voltage gauge • Warning lamps • Information display • Tachometer • Fuel gauge • A/T oil temperature gauge • Odo/trip meter • Indicator lamps • Warning chime
IPDM E/R	IPDM E/R reads the ON/OFF signals of the oil pressure switch and transmits the oil pressure switch signal to the combination meter via BCM with CAN communication line.
Fuel level sensor unit	Refer to MWI-36. "Description" .
Oil pressure switch	Refer to MWI-38. "Description" .
ECM	<p>Transmits the following signals to the combination meter with CAN communication line.</p> <ul style="list-style-type: none"> • Engine speed signal • Engine coolant temperature signal • Fuel consumption monitor signal

METER SYSTEM

< FUNCTION DIAGNOSIS >

Unit	Description
ABS actuator and electric unit (control unit)	Transmits the vehicle speed signal to the combination meter with CAN communication line.
BCM	<ul style="list-style-type: none"> • Transmits signals provided by various units to the combination meter with CAN communication line. • Transmits the security signal to the combination meter.
TCM	<ul style="list-style-type: none"> • Transmits shift position signal to the combination meter with CAN communication line. • Transmits A/T oil temperature signal to the combination meter with CAN communication line.
Washer level switch	Transmits the washer level signal to the combination meter.
Brake fluid level switch	Transmits the brake fluid level switch signal to the combination meter.
Parking brake switch	Refer to MWI-39, "Description" .

SPEEDOMETER

SPEEDOMETER : System Diagram

INFOID:000000004918008

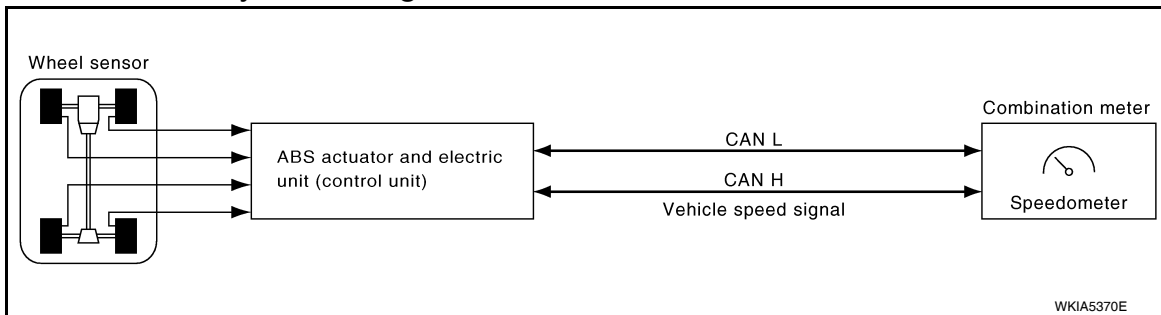

SPEEDOMETER : System Description

INFOID:000000004918009

The ABS actuator and electric unit (control unit) provides a vehicle speed signal to the combination meter via CAN communication lines.

METER SYSTEM

< FUNCTION DIAGNOSIS >

SPEEDOMETER : Component Parts Location

INFOID:000000005266455

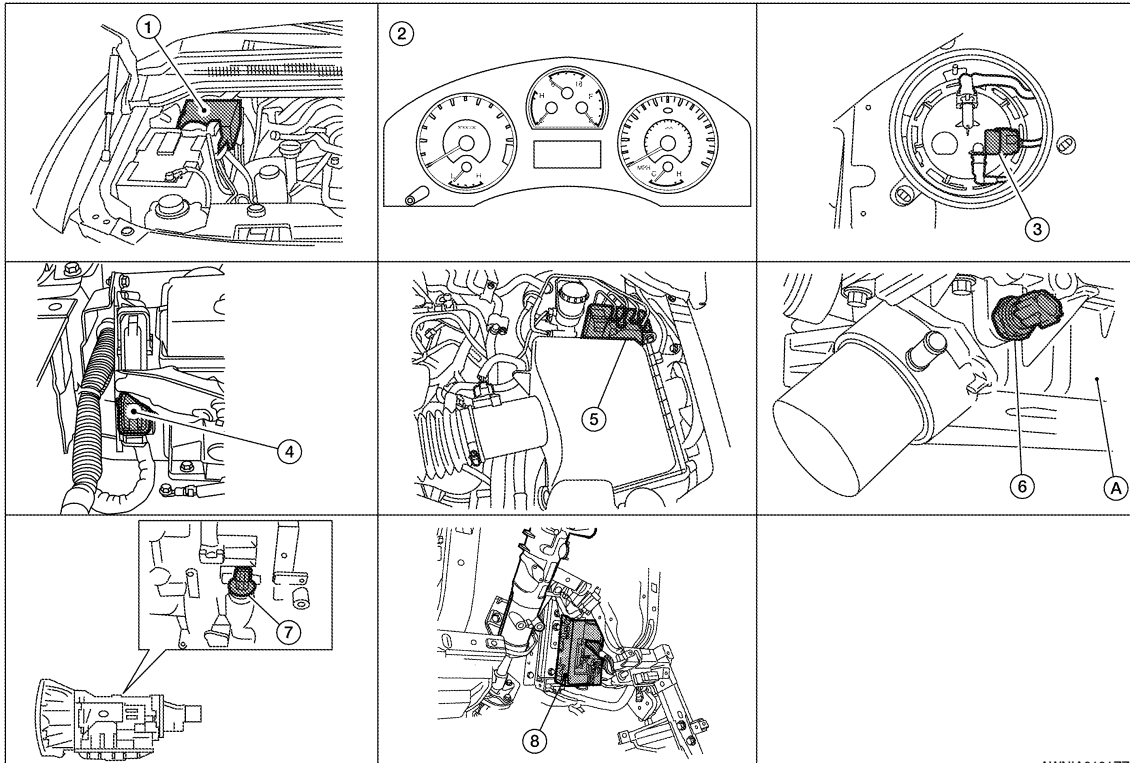

AWNIA0101ZZ

- | | | |
|--|---|---|
| 1. IPDM E/R E122, E124 | 2. Combination meter M23, M24 | 3. Fuel level sensor unit and fuel pump C5 |
| 4. ECM E16 (view with battery removed) | 5. ABS actuator and electric unit (control unit) E125 | 6. Oil pressure switch F4
A: Oil pan (upper) |
| 7. A/T assembly F9 | 8. BCM M18, M19 (view with instrument lower panel LH removed) | |

SPEEDOMETER : Component Description

INFOID:0000000004918011

Unit	Description
Combination meter	Indicates the vehicle speed according to the vehicle speed signal received from ABS actuator and electric unit (control unit) via CAN communication.
ABS actuator and electric unit (control unit)	Transmits the vehicle speed signal to the combination meter with CAN communication line.

TACHOMETER

MWI

TACHOMETER : System Diagram

INFOID:0000000004918012

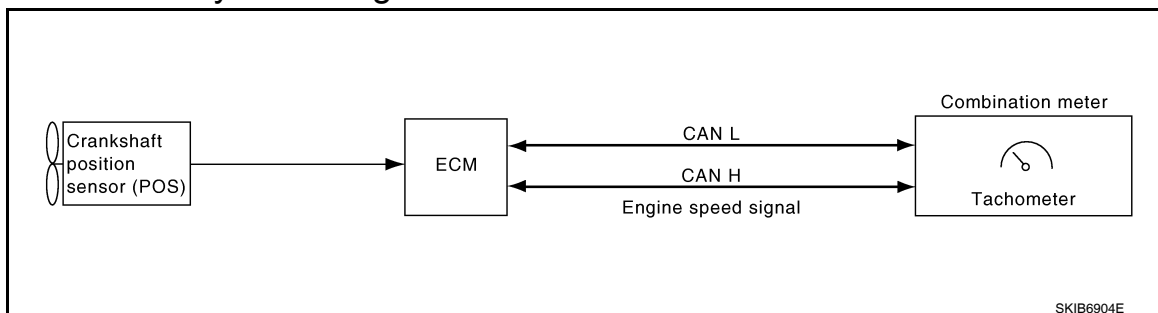

SKIB6904E

METER SYSTEM

< FUNCTION DIAGNOSIS >

TACHOMETER : System Description

INFOID:000000004918013

The tachometer indicates engine speed in revolutions per minute (rpm).
The ECM provides an engine speed signal to the combination meter via CAN communication lines.

TACHOMETER : Component Parts Location

INFOID:000000005266456

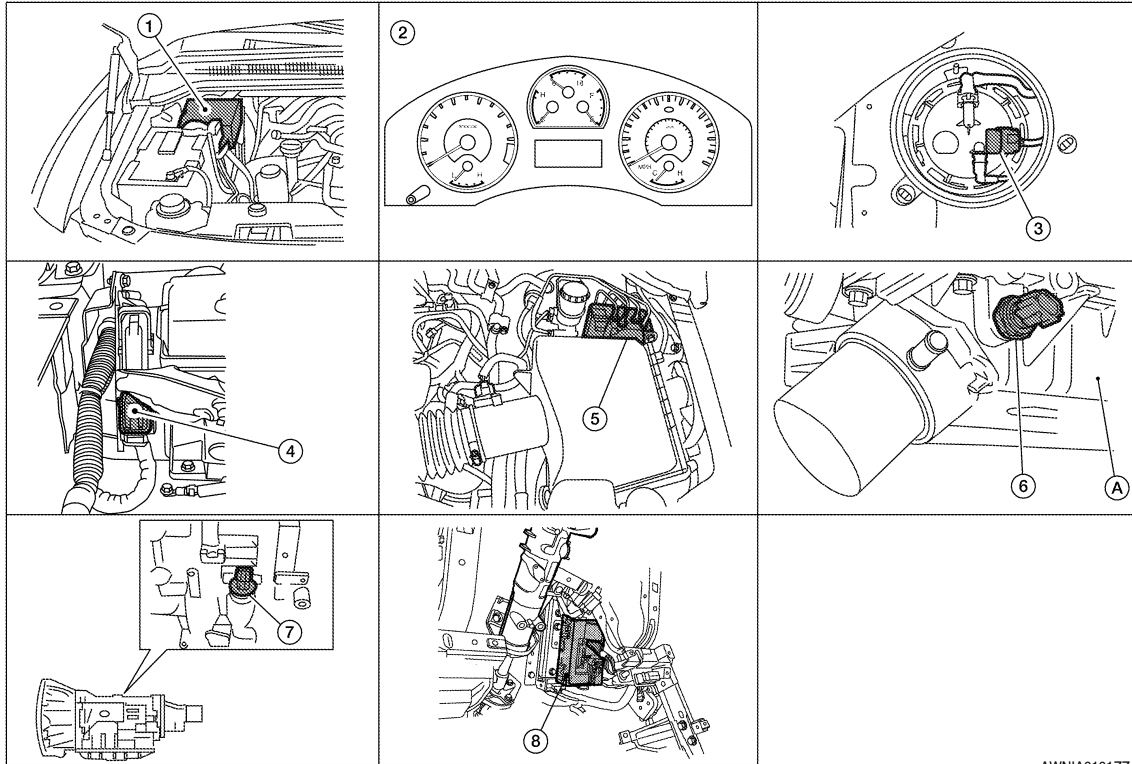

AWNIA0101ZZ

- | | | |
|--|---|---|
| 1. IPDM E/R E122, E124 | 2. Combination meter M23, M24 | 3. Fuel level sensor unit and fuel pump C5 |
| 4. ECM E16 (view with battery removed) | 5. ABS actuator and electric unit (control unit) E125 | 6. Oil pressure switch F4
A: Oil pan (upper) |
| 7. A/T assembly F9 | 8. BCM M18, M19 (view with instrument lower panel LH removed) | |

TACHOMETER : Component Description

INFOID:000000004918015

Unit	Description
Combination meter	Indicates the engine speed in RPM according to the engine speed signal received from ECM via CAN communication.
ECM	Transmits the engine speed signal to the combination meter with CAN communication line.

ENGINE COOLANT TEMPERATURE GAUGE

METER SYSTEM

< FUNCTION DIAGNOSIS >

ENGINE COOLANT TEMPERATURE GAUGE : System Diagram

INFOID:000000004918016

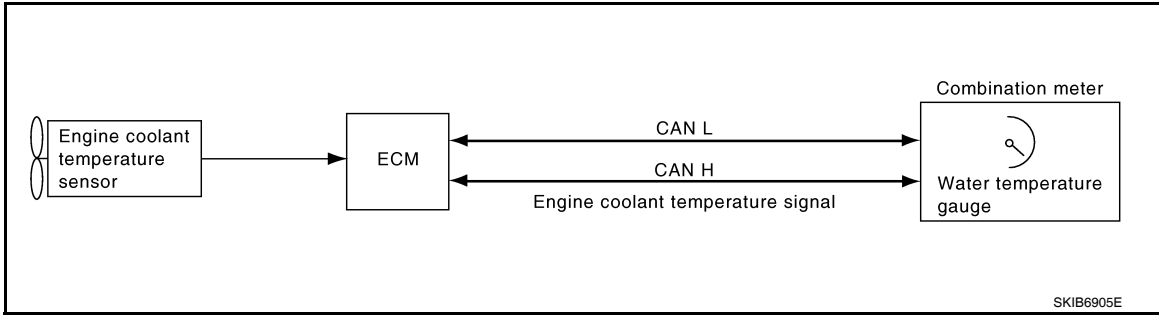

ENGINE COOLANT TEMPERATURE GAUGE : System Description

INFOID:000000004918017

The engine coolant temperature gauge indicates the engine coolant temperature. The ECM provides an engine coolant temperature signal to the combination meter via CAN communication lines.

ENGINE COOLANT TEMPERATURE GAUGE : Component Parts Location

INFOID:000000005266457

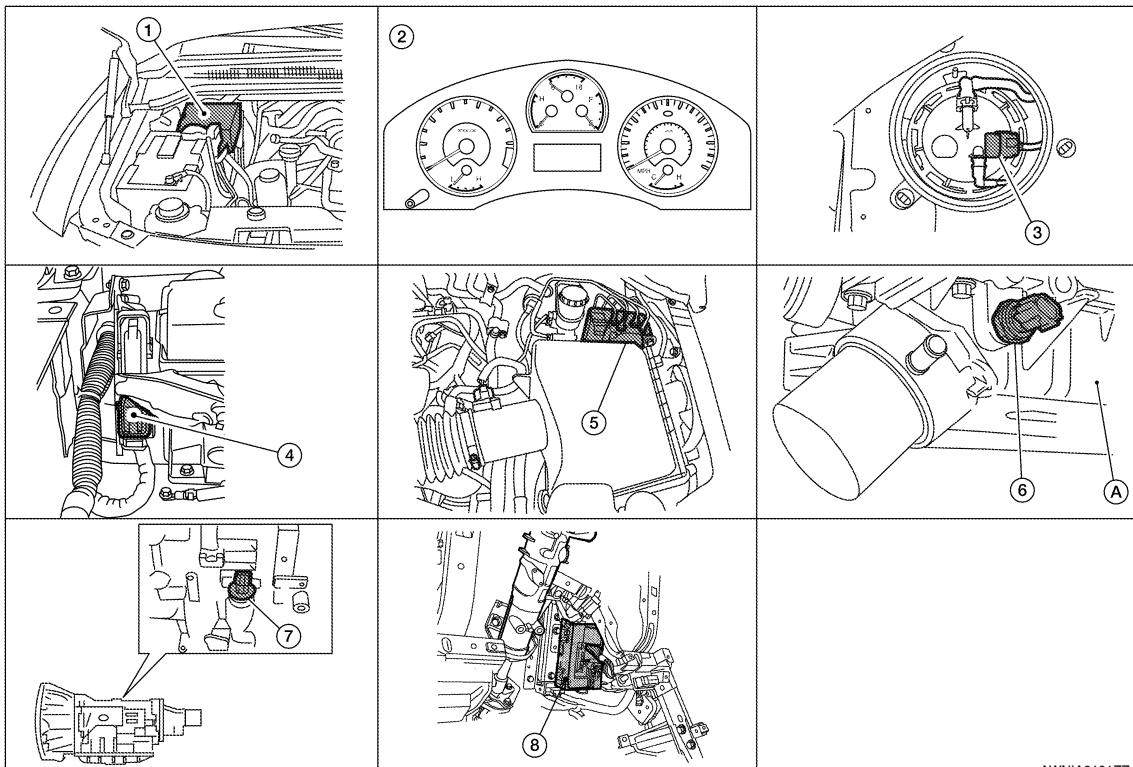

AWNIA0101ZZ

- | | | |
|--|---|---|
| 1. IPDM E/R E122, E124 | 2. Combination meter M23, M24 | 3. Fuel level sensor unit and fuel pump C5 |
| 4. ECM E16 (view with battery removed) | 5. ABS actuator and electric unit (control unit) E125 | 6. Oil pressure switch F4
A: Oil pan (upper) |
| 7. A/T assembly F9 | 8. BCM M18, M19 (view with instrument lower panel LH removed) | |

A
B
C
D
E
F
G
H
I
J
K
L
M
N
O
P



METER SYSTEM

< FUNCTION DIAGNOSIS >

ENGINE COOLANT TEMPERATURE GAUGE : Component Description

INFOID:000000004918019

Unit	Description
Combination meter	Indicates the engine coolant temperature according to the engine coolant temperature signal received from ECM via CAN communication.
ECM	Transmits the engine coolant temperature signal to the combination meter via CAN communication.

FUEL GAUGE

FUEL GAUGE : System Diagram

INFOID:000000004918020

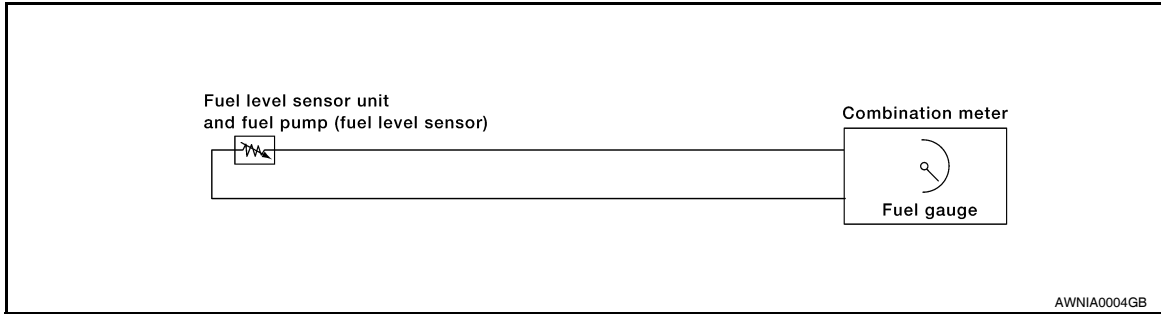

FUEL GAUGE : System Description

INFOID:000000004918021

The fuel gauge indicates the approximate fuel level in the fuel tank. The fuel gauge is regulated by the unified meter control unit and a variable resistor signal supplied by the fuel level sensor unit.

FUEL GAUGE : Component Parts Location

INFOID:0000000005266458

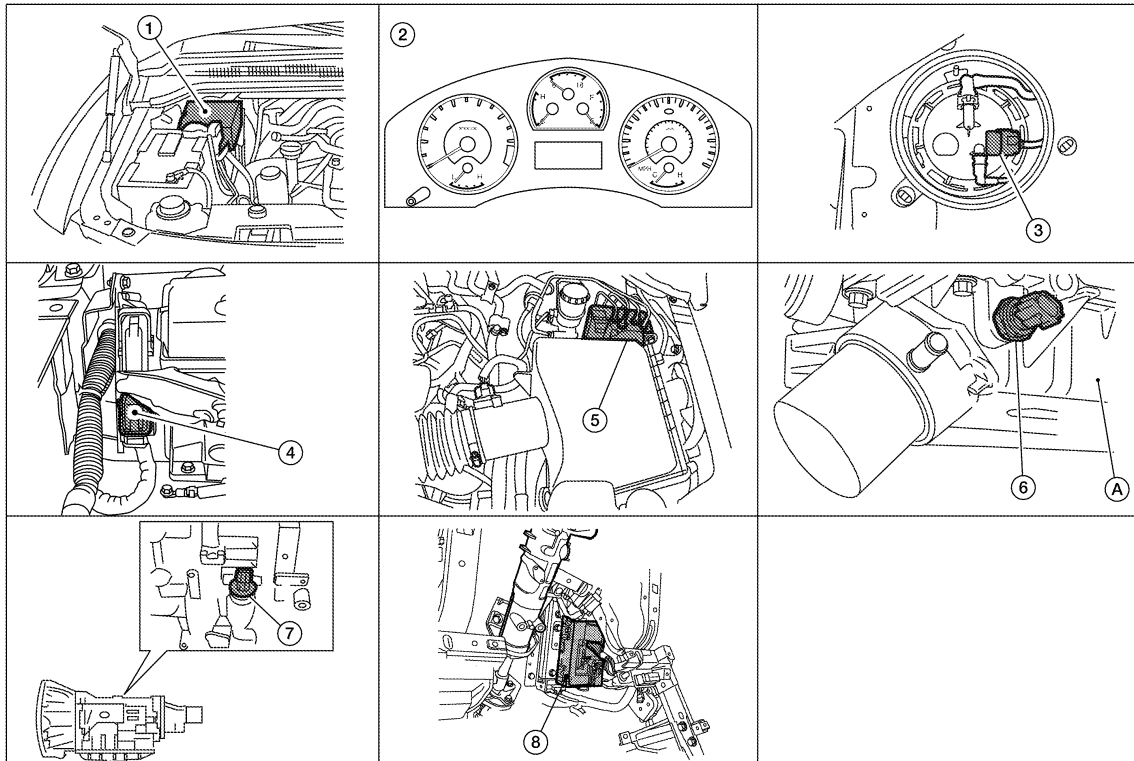

METER SYSTEM

< FUNCTION DIAGNOSIS >

- | | | |
|--|---|---|
| 1. IPDM E/R E122, E124 | 2. Combination meter M23, M24 | 3. Fuel level sensor unit and fuel pump C5 |
| 4. ECM E16 (view with battery removed) | 5. ABS actuator and electric unit (control unit) E125 | 6. Oil pressure switch F4
A: Oil pan (upper) |
| 7. A/T assembly F9 | 8. BCM M18, M19 (view with instrument lower panel LH removed) | |

FUEL GAUGE : Component Description

INFOID:000000004918023

Unit	Description
Combination meter	Indicates the fuel level according to the fuel level sensor signal received from the fuel level sensor unit.
Fuel level sensor unit	Refer to MWI-36. "Description" .

ENGINE OIL PRESSURE GAUGE

ENGINE OIL PRESSURE GAUGE : System Diagram

INFOID:000000004918024

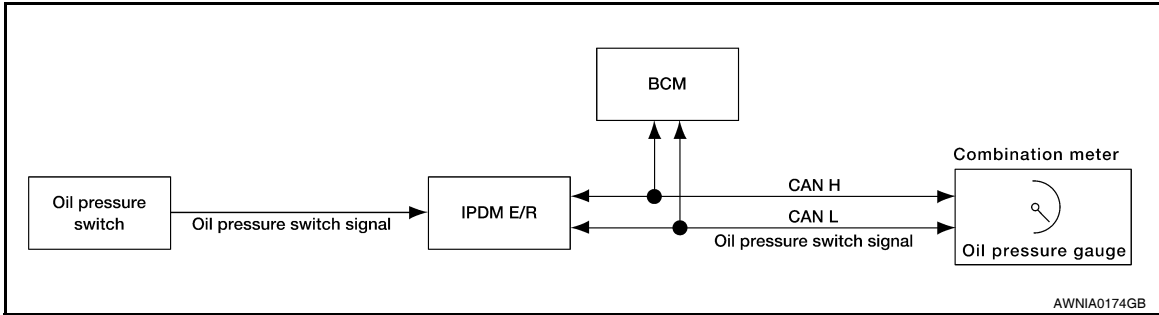

ENGINE OIL PRESSURE GAUGE : System Description

INFOID:000000004918025

The engine oil pressure gauge indicates whether the engine oil pressure is low or normal. The oil pressure gauge is controlled by the IPDM E/R. The IPDM E/R reads the ON/OFF signals from the oil pressure switch and transmits the oil pressure switch signal to the combination meter via BCM with the CAN communication line. The oil pressure gauge displays a low or normal indication according to the oil pressure switch signal received via CAN communication.

MWI

METER SYSTEM

< FUNCTION DIAGNOSIS >

ENGINE OIL PRESSURE GAUGE : Component Parts Location

INFOID:000000005266459

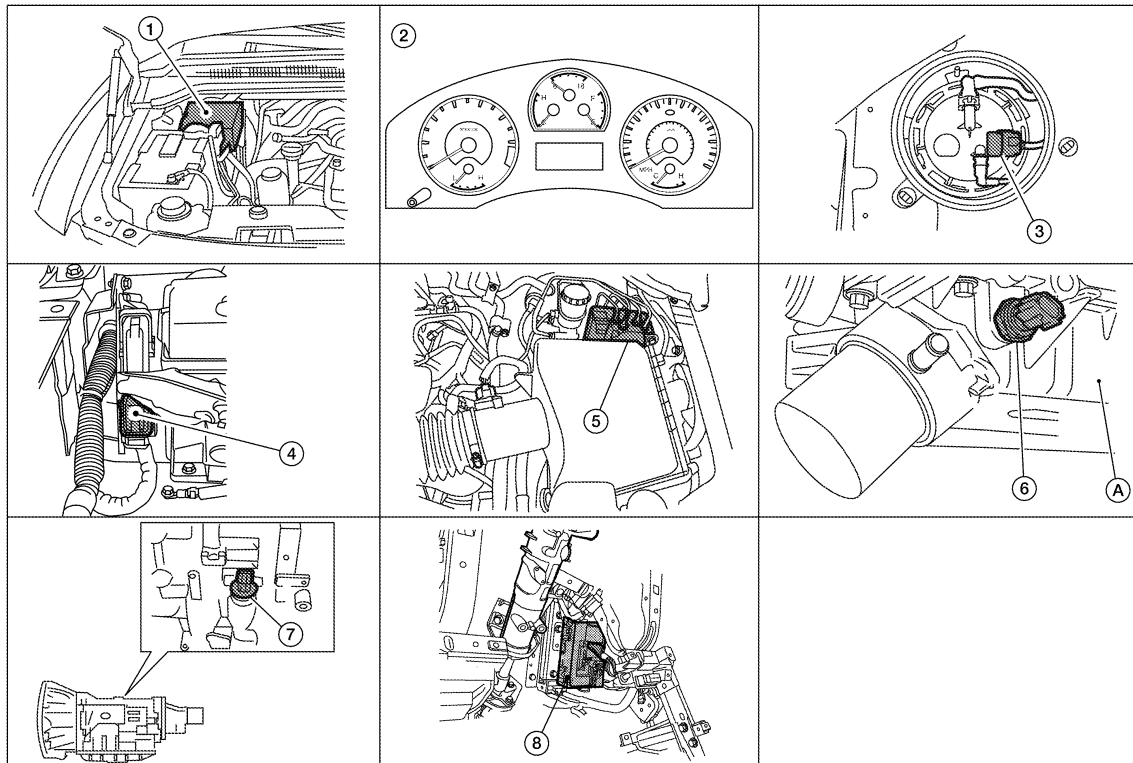

AWNIA0101ZZ

- | | | |
|--|---|---|
| 1. IPDM E/R E122, E124 | 2. Combination meter M23, M24 | 3. Fuel level sensor unit and fuel pump C5 |
| 4. ECM E16 (view with battery removed) | 5. ABS actuator and electric unit (control unit) E125 | 6. Oil pressure switch F4
A: Oil pan (upper) |
| 7. A/T assembly F9 | 8. BCM M18, M19 (view with instrument lower panel LH removed) | |

ENGINE OIL PRESSURE GAUGE : Component Description

INFOID:000000004918027

Unit	Description
Combination meter	Indicates the engine oil pressure (low/normal) according to the oil pressure switch signal received from BCM with CAN communication line.
IPDM E/R	Reads the ON/OFF signals from the oil pressure switch and transmits the oil pressure switch signal to the combination meter via BCM with the CAN communication line.
Oil pressure switch	Refer to MWI-38. "Description" .
BCM	Transmits the oil pressure switch signal received from IPDM E/R via CAN communication to the combination meter via CAN communication.

A/T OIL TEMPERATURE GAUGE

METER SYSTEM

< FUNCTION DIAGNOSIS >

A/T OIL TEMPERATURE GAUGE : System Diagram

INFOID:000000004918028

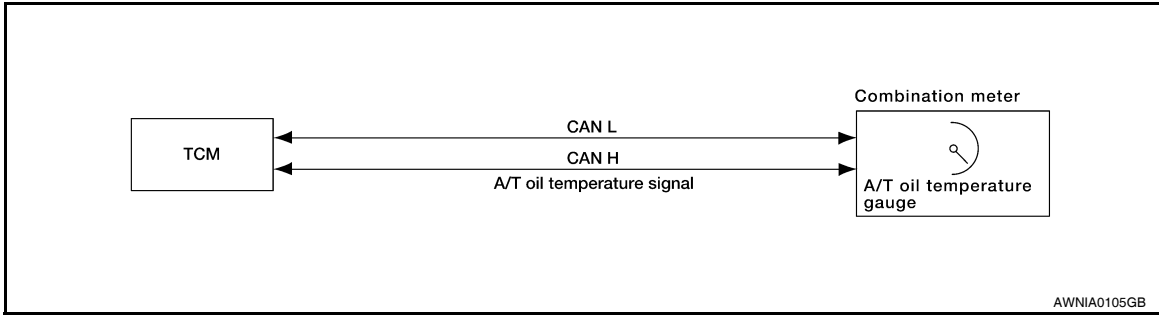

AWNIA0105GB

A/T OIL TEMPERATURE GAUGE : System Description

INFOID:000000004918029

The A/T oil temperature gauge indicates the A/T fluid temperature. The TCM (transmission control module) provides an A/T fluid temperature signal to combination meter via CAN communication lines.

A/T OIL TEMPERATURE GAUGE : Component Parts Location

INFOID:0000000005266460

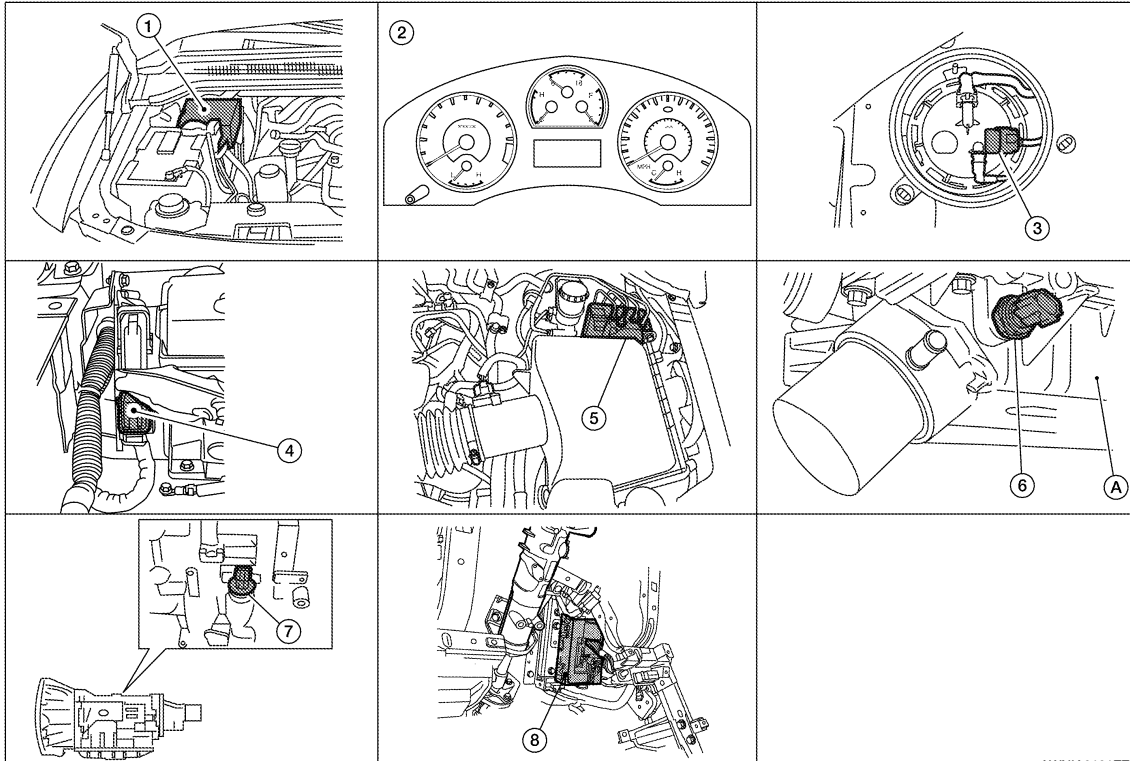

AWNIA0101ZZ

- | | | |
|--|---|---|
| 1. IPDM E/R E122, E124 | 2. Combination meter M23, M24 | 3. Fuel level sensor unit and fuel pump C5 |
| 4. ECM E16 (view with battery removed) | 5. ABS actuator and electric unit (control unit) E125 | 6. Oil pressure switch F4
A: Oil pan (upper) |
| 7. A/T assembly F9 | 8. BCM M18, M19 (view with instrument lower panel LH removed) | |

A
B
C
D
E
F
G
H
I
J
K
L
M
N
O
P

MWI

METER SYSTEM

< FUNCTION DIAGNOSIS >

A/T OIL TEMPERATURE GAUGE : Component Description

INFOID:000000004918031

Unit	Description
Combination meter	Indicates the A/T oil temperature according to the A/T oil temperature signal received from TCM via CAN communication.
TCM	Transmits the A/T oil temperature signal to the combination meter via CAN communication.

VOLTAGE GAUGE

VOLTAGE GAUGE : System Diagram

INFOID:000000004918032

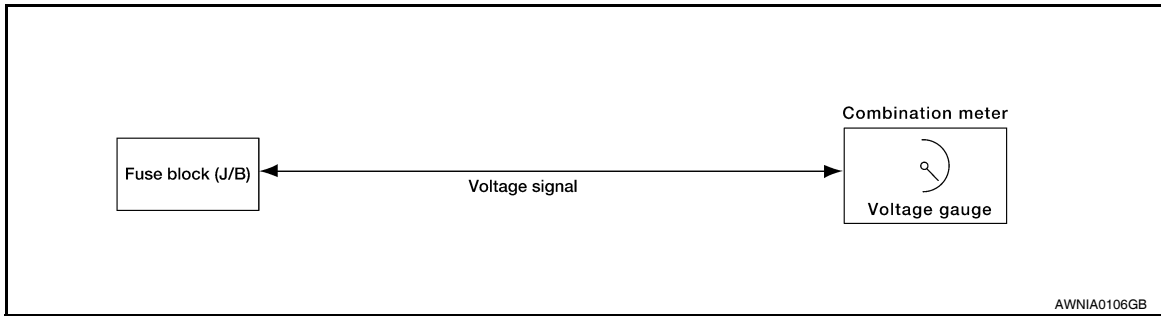

VOLTAGE GAUGE : System Description

INFOID:000000004918033

The voltage gauge indicates the battery/charging system voltage. The voltage gauge is regulated by the unified meter control unit.

VOLTAGE GAUGE : Component Parts Location

INFOID:000000005266461

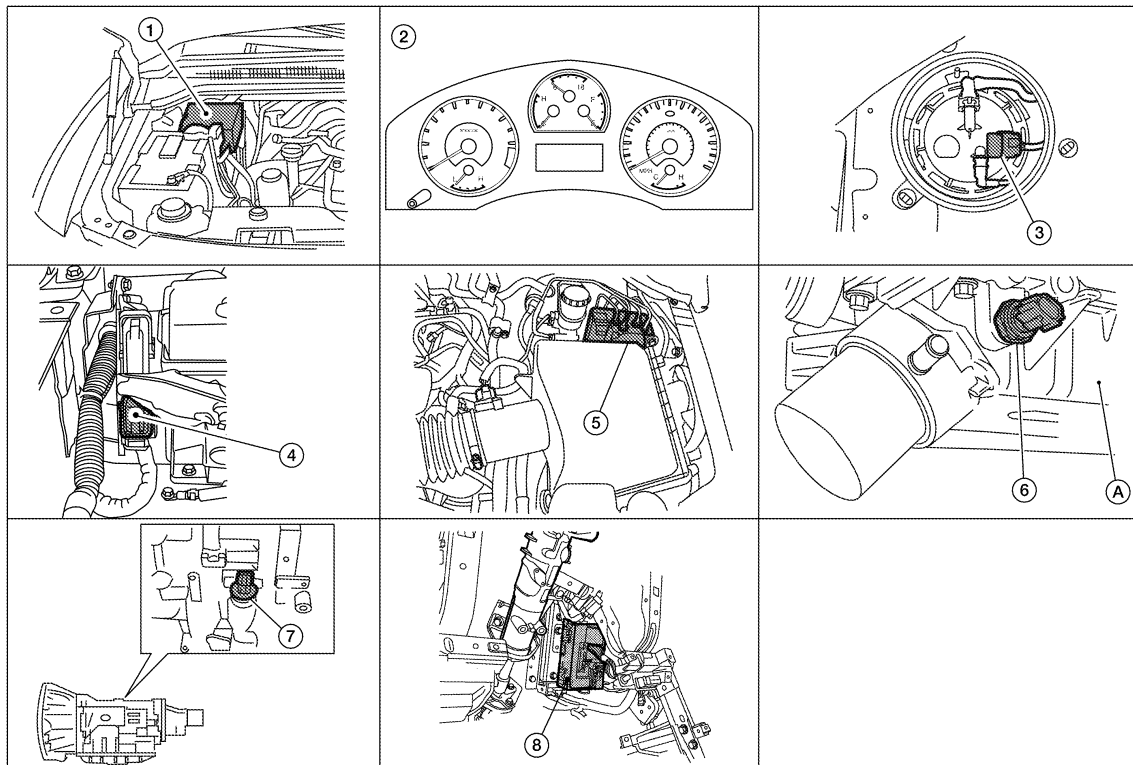

AWNIA0101ZZ

1. IPDM E/R E122, E124

2. Combination meter M23, M24

3. Fuel level sensor unit and fuel pump C5

METER SYSTEM

< FUNCTION DIAGNOSIS >

- | | | |
|--|---|---|
| 4. ECM E16 (view with battery removed) | 5. ABS actuator and electric unit (control unit) E125 | 6. Oil pressure switch F4
A: Oil pan (upper) |
| 7. A/T assembly F9 | 8. BCM M18, M19 (view with instrument lower panel LH removed) | |

VOLTAGE GAUGE : Component Description

INFOID:000000004918035

Unit	Description
Combination meter	Indicates the battery voltage according to the voltage signal received from the fuse block (J/B).
Fuse block (J/B)	Transmits the battery voltage signal to the combination meter.

ODO/TRIP METER

ODO/TRIP METER : System Diagram

INFOID:000000004918036

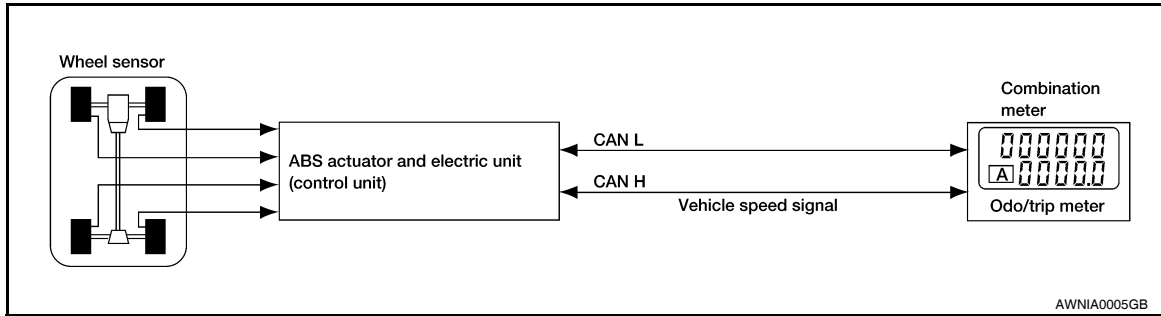

ODO/TRIP METER : System Description

INFOID:000000004918037

The vehicle speed signal and the memory signals from the meter memory circuit are processed by the combination meter and the mileage is displayed.

HOW TO CHANGE THE DISPLAY FOR ODO/TRIP METER

Refer to Owner's Manual for odo/trip meter operating instructions.

A
B
C
D
E
F
G
H
I
J
K
L
M

MWI

METER SYSTEM

< FUNCTION DIAGNOSIS >

ODO/TRIP METER : Component Parts Location

INFOID:000000005266462

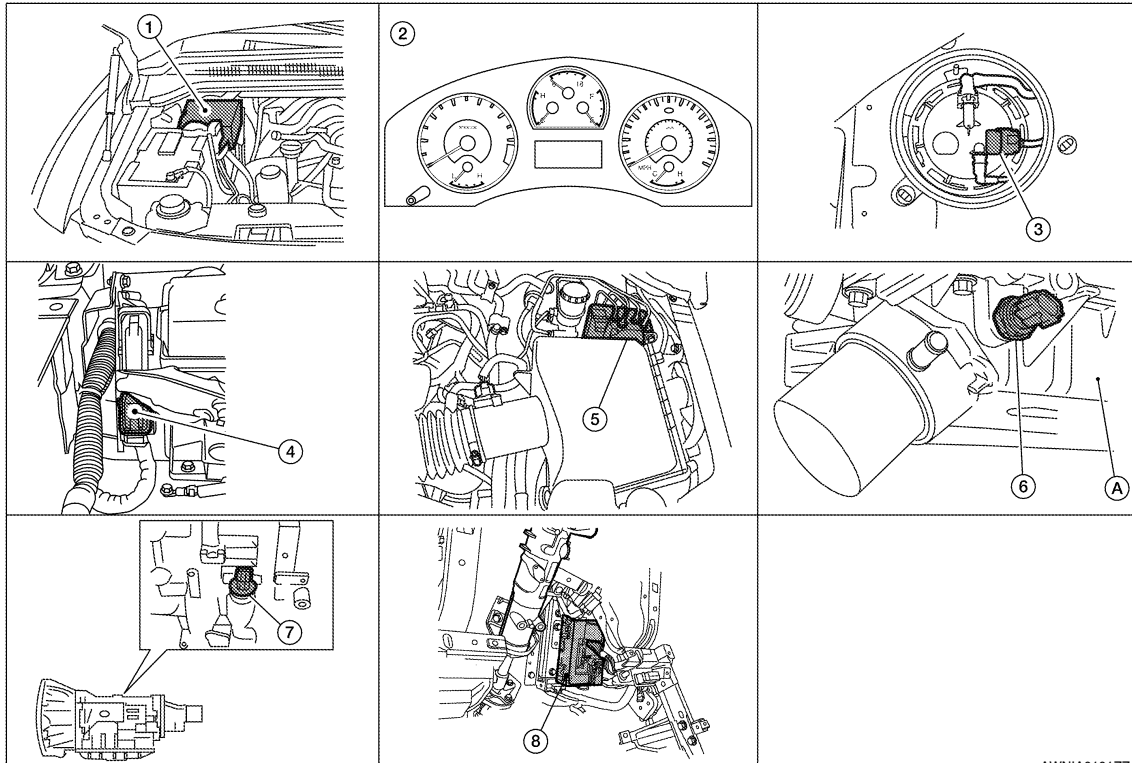

AWNIA0101ZZ

- | | | |
|--|---|---|
| 1. IPDM E/R E122, E124 | 2. Combination meter M23, M24 | 3. Fuel level sensor unit and fuel pump C5 |
| 4. ECM E16 (view with battery removed) | 5. ABS actuator and electric unit (control unit) E125 | 6. Oil pressure switch F4
A: Oil pan (upper) |
| 7. A/T assembly F9 | 8. BCM M18, M19 (view with instrument lower panel LH removed) | |

ODO/TRIP METER : Component Description

INFOID:0000000004918039

Unit	Description
Combination meter	Converts the vehicle speed signal received from the ABS actuator and electric unit (control unit) via CAN communication to mileage, and it displays the accumulated mileage to the odo/trip meter.
ABS actuator and electric unit (control unit)	Transmits the vehicle speed signal to the combination meter via CAN communication.

SHIFT POSITION INDICATOR

SHIFT POSITION INDICATOR : System Diagram

INFOID:0000000004918040

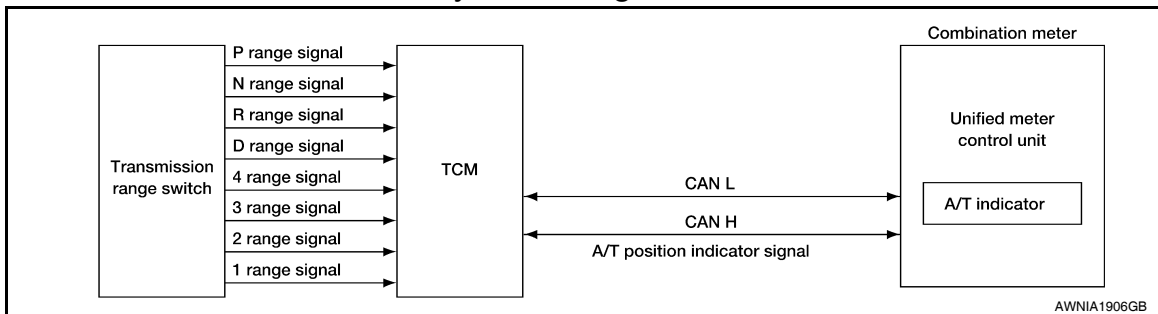

AWNIA1906GB

METER SYSTEM

< FUNCTION DIAGNOSIS >

SHIFT POSITION INDICATOR : System Description

INFOID:000000004918041

The TCM receives A/T indicator signals from the transmission range switch. The TCM then sends A/T position indicator signals to the combination meter via CAN communication lines. The combination meter indicates the received shift position.

SHIFT POSITION INDICATOR : Component Parts Location

INFOID:000000005266463

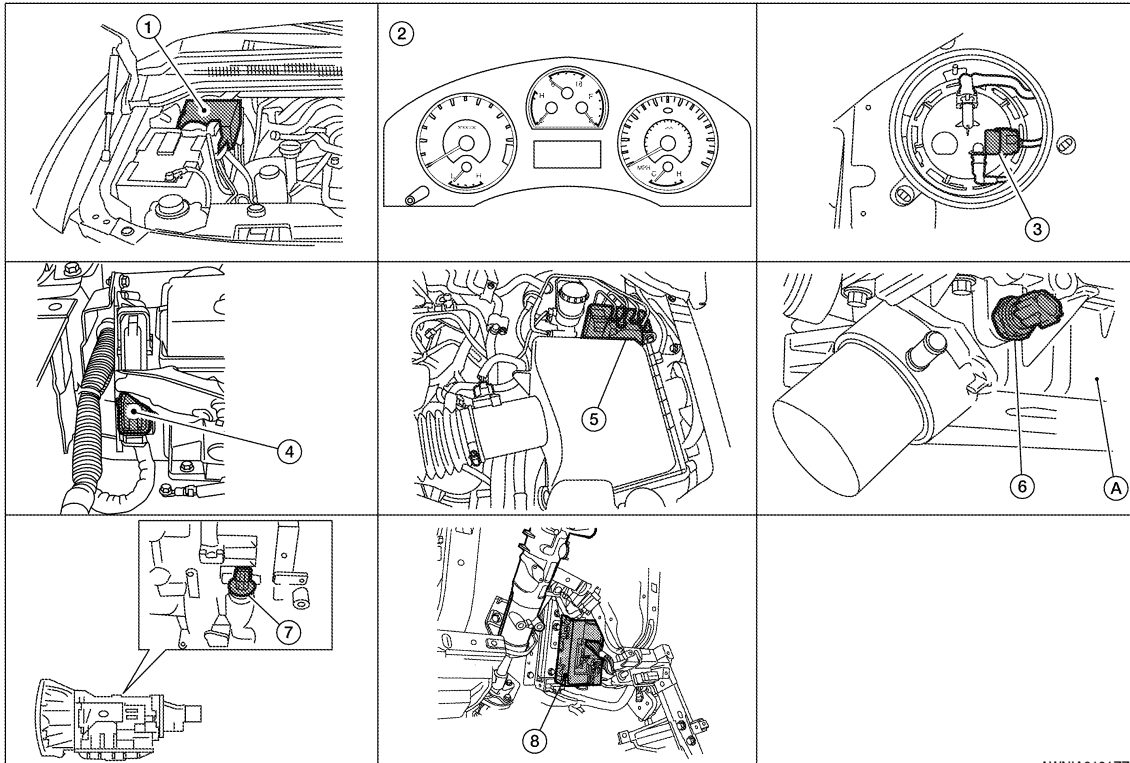

AWNIA0101ZZ

- | | | |
|--|---|---|
| 1. IPDM E/R E122, E124 | 2. Combination meter M23, M24 | 3. Fuel level sensor unit and fuel pump C5 |
| 4. ECM E16 (view with battery removed) | 5. ABS actuator and electric unit (control unit) E125 | 6. Oil pressure switch F4
A: Oil pan (upper) |
| 7. A/T assembly F9 | 8. BCM M18, M19 (view with instrument lower panel LH removed) | |

SHIFT POSITION INDICATOR : Component Description

INFOID:000000004918043

Unit	Description
Combination meter	Displays the shift position on the information display using shift position signal received from TCM.
TCM	Transmits the shift position signal to the combination meter via CAN communication.

WARNING LAMPS/INDICATOR LAMPS

A
B
C
D
E
F
G
H
I
J
K
L
M
O
P

MWI

METER SYSTEM

< FUNCTION DIAGNOSIS >

WARNING LAMPS/INDICATOR LAMPS : System Diagram

INFOID:000000004918044

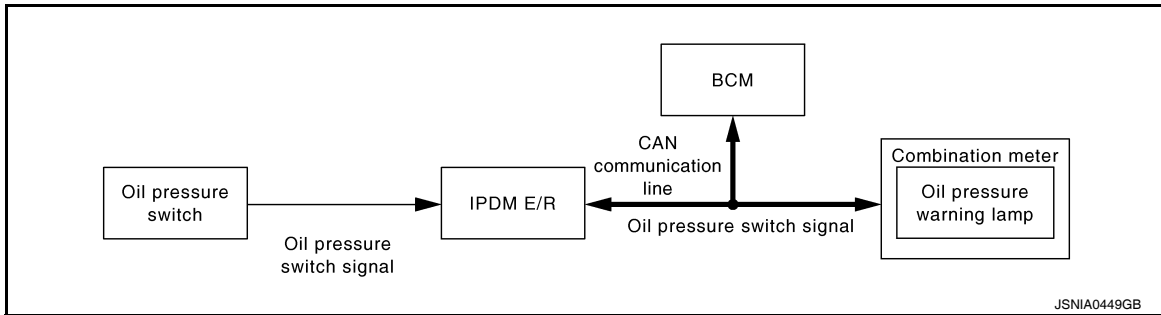

JSNIA0449GB

WARNING LAMPS/INDICATOR LAMPS : System Description

INFOID:000000004918045

OIL PRESSURE WARNING LAMP

- IPDM E/R reads the ON/OFF signals from the oil pressure switch and transmits the oil pressure switch signal to the combination meter via BCM with the CAN communication line.
- The combination meter turns the oil pressure warning lamp ON/OFF according to the oil pressure switch signal received via CAN communication.

WARNING LAMPS/INDICATOR LAMPS : Component Parts Location

INFOID:000000005266464

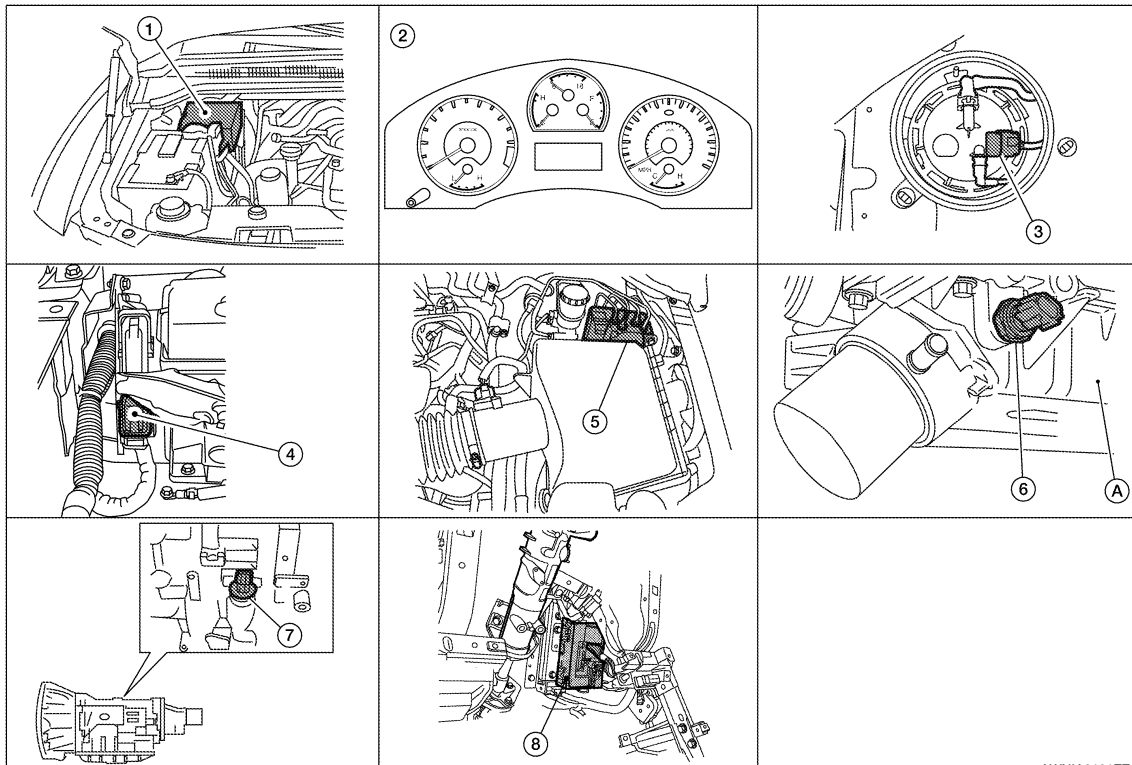

AWNIA0101ZZ

- | | | |
|--|---|---|
| 1. IPDM E/R E122, E124 | 2. Combination meter M23, M24 | 3. Fuel level sensor unit and fuel pump C5 |
| 4. ECM E16 (view with battery removed) | 5. ABS actuator and electric unit (control unit) E125 | 6. Oil pressure switch F4
A: Oil pan (upper) |
| 7. A/T assembly F9 | 8. BCM M18, M19 (view with instrument lower panel LH removed) | |

METER SYSTEM

< FUNCTION DIAGNOSIS >

WARNING LAMPS/INDICATOR LAMPS : Component Description

INFOID:000000004918047

Unit	Description
Combination meter	Turns the oil pressure warning lamp ON/OFF according to the oil pressure switch signal received from BCM by means of communication.
IPDM E/R	Reads the ON/OFF signals from the oil pressure switch and transmits the oil pressure switch signal to the combination meter via BCM with the CAN communication line.
Oil pressure switch	Refer to MWI-38, "Description" .
BCM	Transmits the oil pressure switch signal received from IPDM E/R via CAN communication to the combination meter via CAN communication.

INFORMATION DISPLAY

INFORMATION DISPLAY : System Diagram

INFOID:000000004918048

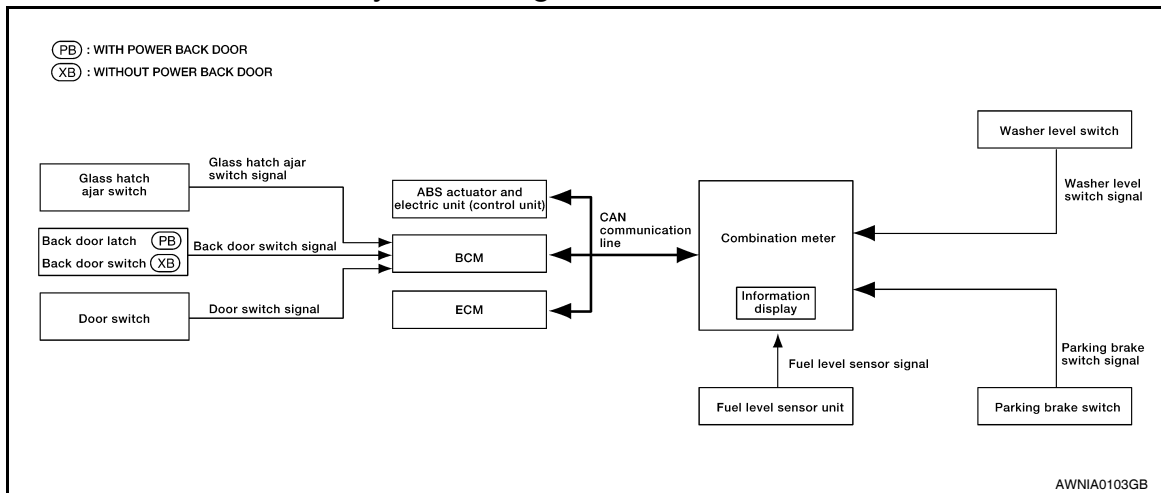

INFORMATION DISPLAY : System Description

INFOID:000000004918049

FUNCTION

The information display can indicate the following items.

- Trip A/B
- Intelligent Key operation information (with Intelligent Key)
- Warning/Indication messages (Door open, liftgate open, liftgate glass open, low fuel, low washer fluid, parking brake)

DOOR OPEN WARNING

This warning appears when the ignition switch is ON and the front door LH, front door RH, rear door LH or rear door RH is opened. The BCM receives a door switch signal from the front door switch LH, front door switch RH, rear door switch LH and rear door switch RH. The BCM sends the door switch signal to the combination meter via CAN communication lines. Then, when the ignition switch is turned ON, the warning message is displayed.

LIFTGATE OPEN WARNING

This warning appears when the ignition switch is ON and the back door is opened. The BCM receives a door switch signal from the back door latch (with power back door) or back door switch (without power back door). The BCM sends the door switch signal to the combination meter via CAN communication lines. Then, when the ignition switch is turned ON, the warning message is displayed.

LIFTGATE GLASS OPEN WARNING

This warning appears when the ignition switch is ON and the glass hatch is opened. The BCM receives a glass hatch switch signal from the glass hatch ajar switch. The BCM sends the glass hatch switch signal to the combination meter via CAN communication lines. Then, when the ignition switch is turned ON, the warning message is displayed.

LOW FUEL WARNING

A
B
C
D
E
F
G
H
I
J
K
L
M
N
O
P

MWI

METER SYSTEM

< FUNCTION DIAGNOSIS >

This warning appears when the fuel level in the fuel tank is less than approximately 11.4 ℓ (3 US gal, 2.5 Imp gal). A variable resistor signal is supplied to the combination meter from the fuel level sensor unit to determine the amount of fuel in the fuel tank.

LOW WINDSHIELD WASHER FLUID WARNING

This warning appears when the windshield washer fluid level is low. When the windshield washer fluid level is low, the washer level switch provides a ground signal to the combination meter (unified meter control unit). Once fluid is added, the message will stay on for 30 seconds and then turn off.

PARKING BRAKE INDICATOR

When the parking brake is applied, the parking brake switch provides a ground signal to the combination meter (unified meter control unit). Then, when the ignition switch is turned ON and vehicle speed is greater than 7 km/h (4 MPH), the message is displayed.

Refer to Owner's Manual for additional information display items.

INFORMATION DISPLAY : Component Parts Location

INFOID:000000005266465

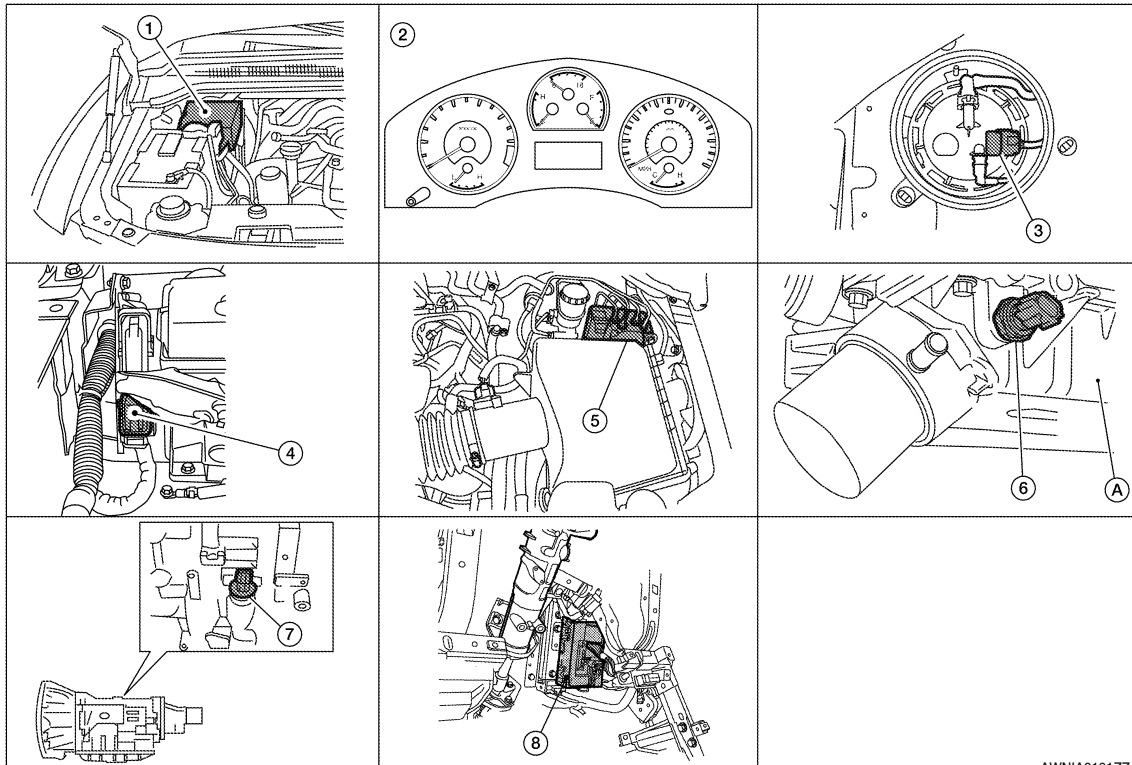

AWNIA0101ZZ

- | | | |
|--|---|---|
| 1. IPDM E/R E122, E124 | 2. Combination meter M23, M24 | 3. Fuel level sensor unit and fuel pump C5 |
| 4. ECM E16 (view with battery removed) | 5. ABS actuator and electric unit (control unit) E125 | 6. Oil pressure switch F4
A: Oil pan (upper) |
| 7. A/T assembly F9 | 8. BCM M18, M19 (view with instrument lower panel LH removed) | |

INFORMATION DISPLAY : Component Description

INFOID:000000004918051

Unit	Description
Combination meter	Controls the information display according to the signal received from each unit.
Fuel level sensor unit	Refer to MWI-36, "Description" .

METER SYSTEM

< FUNCTION DIAGNOSIS >

Unit	Description	
ECM	Transmits the following signals to the combination meter via CAN communication line. <ul style="list-style-type: none"> • Engine speed signal • Fuel consumption monitor signal 	A
ABS actuator and electric unit (control unit)	Transmits the vehicle speed signal to the combination meter via CAN communication line.	B
BCM	Transmits signals provided by various units to the combination meter via CAN communication line.	
Washer level switch	Transmits the washer level signal to the combination meter.	C
Parking brake switch	Refer to MWI-39. "Description" .	
Door switch	Transmits the door switch signals to BCM.	D
Back door switch (without power back door)	Transmits the back door switch signal to BCM.	E
Back door latch (door ajar switch) (with power back door)		E
Glass hatch ajar switch	Transmits the glass hatch ajar switch signal to BCM.	F

A
B
C
D
E
F
G
H
I
J
K
L
M
O
P

MWI

COMPASS

< FUNCTION DIAGNOSIS >

COMPASS

Description

INFOID:000000005326709

DESCRIPTION

With the ignition switch in the ON position, and the mode or (N) switch ON, the compass display will indicate the direction the vehicle is heading.

Vehicle direction is displayed as follows:

- N: north
- E: east
- S: south
- W: west

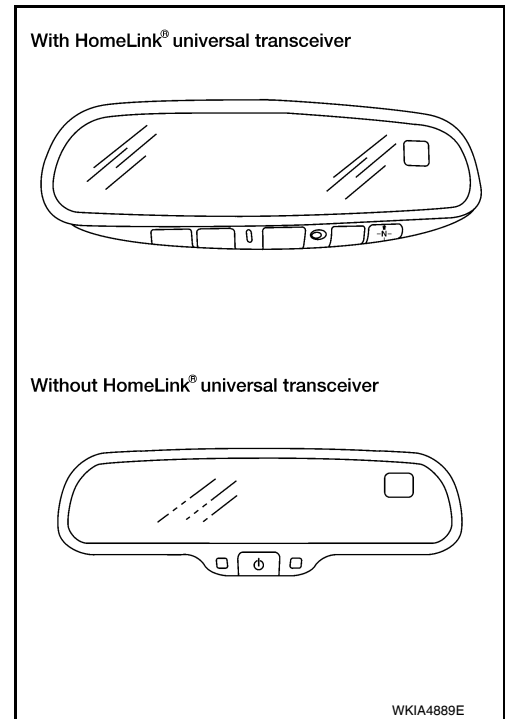

ZONE VARIATION SETTING PROCEDURE

The difference between magnetic north and geographical north can sometimes be great enough to cause false compass readings. This difference is known as variance. In order for the compass to operate properly (accurately) in a particular zone, the zone variation must be calibrated using the following procedure.

Zone Variation Chart

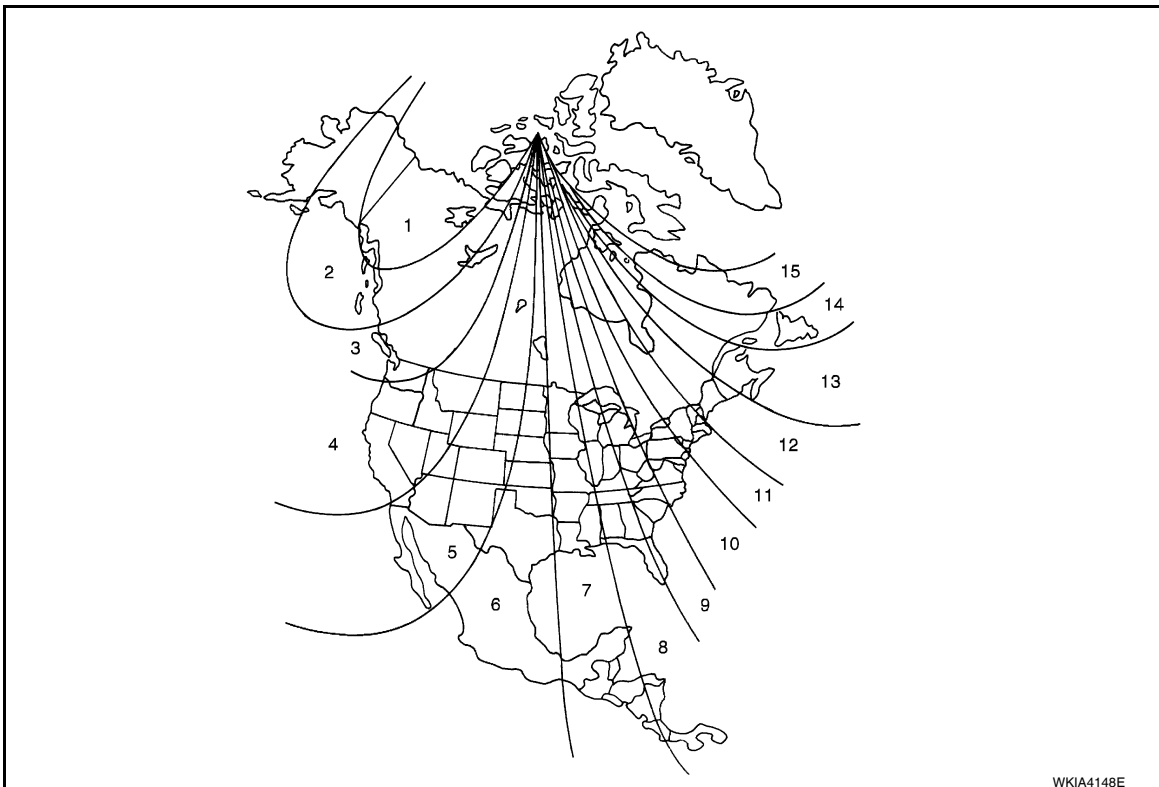

COMPASS

< FUNCTION DIAGNOSIS >

1. Determine your location on the zone map.
2. Turn the ignition switch to the ON position.
3. Press and hold the (N) switch for about 8 seconds (with HomeLink universal transceiver) or the mode switch for about 11 seconds (without HomeLink universal transceiver). The current zone number will appear in the display.
4. Press the mode or (N) switch repeatedly until the desired zone number appears in the display.

Once the desired zone number is displayed, stop pressing the mode or (N) switch and the display will show a compass direction after a few seconds.

NOTE:

Use zone number 5 for Hawaii.

CALIBRATION PROCEDURE

The compass display is equipped with an automatic correction function. If the compass display reads "CAL" or the direction is not shown correctly, perform the correction procedure below.

1. Press and hold the (N) switch for about 10 seconds (with HomeLink universal transceiver) or the mode switch for about 13 seconds (without HomeLink universal transceiver). The display will read "CAL".
2. Drive the vehicle slowly in a circle, in an open, safe place. The initial calibration is completed in about 3 turns.

NOTE:

In places where the terrestrial magnetism is extremely disturbed, the initial correction may start automatically.

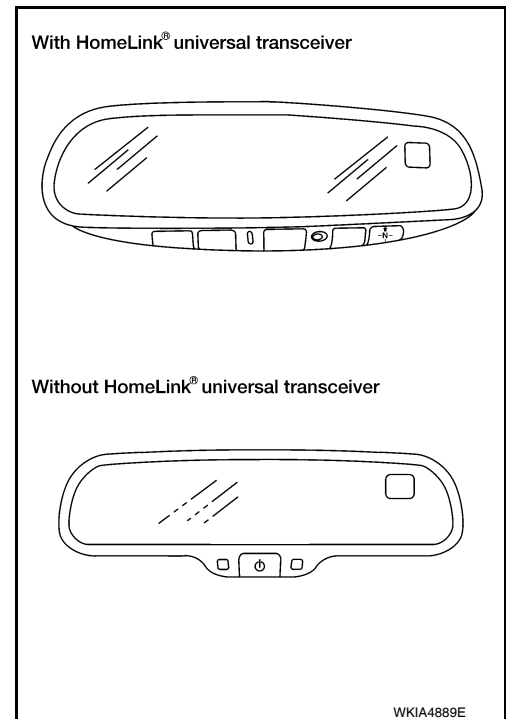

A
B
C
D
E
F
G
H
I
J
K
L
M
N
O
P

MWI

DIAGNOSIS SYSTEM (METER)

< FUNCTION DIAGNOSIS >

DIAGNOSIS SYSTEM (METER)

Diagnosis Description

INFOID:000000004918053

SELF-DIAGNOSIS MODE

The following items can be checked during Combination Meter Self-Diagnosis Mode.

- Gauge sweep and present gauge values.
- Illuminates all odometer/trip meters and A/T indicator segments.
- Illuminates all micro controlled lamps/LEDs regardless of switch position.
- Displays estimated present battery voltage.
- Displays seat belt buckle switch LH status.

OPERATION PROCEDURE

NOTE:

- Once entered, combination meter self-diagnosis mode will function with the ignition switch in ON or START. Combination meter self-diagnosis mode will exit upon turning the ignition switch to OFF or ACC.
- If the diagnosis function is activated with trip A displayed, the mileage on trip A is reset to 0000.0. (Trip B operates the same way.)

To initiate combination meter self-diagnosis mode, refer to the following procedure.

1. Turn the ignition switch ON, while pressing the odometer/trip meter switch for 5 - 8 seconds. When the diagnosis function is activated, the odometer/trip meter will display tEst.

NOTE:

Check combination meter power supply and ground circuit when self-diagnosis mode of combination meter does not start. Refer to [MWI-32, "COMBINATION METER : Diagnosis Procedure"](#). Replace combination meter if normal. Refer to [MWI-106, "Removal and Installation"](#).

COMBINATION METER SELF-DIAGNOSIS MODE FUNCTIONS

To interpret combination meter self-diagnosis mode functions, refer to the following table.

Event	Odometer Display	Description of Test/Data	Notes:
Odometer/trip meter A/B switch held from 5 to 8 seconds (or until released)	tEst		Initiating self-diagnosis mode
Switch released	GAGE	Performs sweep of all gauges, then displays present gauge values.	Gauges sweep within 10 seconds
Switch pressed	(All segments illuminated)	Lights all LCD segments. Compare with picture.	 <p>ALNIA0280ZZ</p>
Switch pressed	bulb	Illuminates all micro-controlled lamps/LEDs.	Part may not be configured for all lamps (functions) that turn on during test. This is normal.
Switch pressed	r XXXX, FAIL	Return to normal operation of all lamps/LEDs and displays "r XXXX".	If a malfunction exists, "FAIL" will flash.
Switch pressed	nrXXXX	Displays Hex ROM rev as stored in NVM.	
Switch pressed	EE XX, FAIL	Displays "EE XX".	If a malfunction exists, "FAIL" will flash.
Switch pressed	dtXXXX	Hex coding of final manufacturing test date.	

DIAGNOSIS SYSTEM (METER)

< FUNCTION DIAGNOSIS >

Event	Odometer Display	Description of Test/Data	Notes:	
Switch pressed (3 times)	Sc1 XX through Epr XX	Displays 8 bit software configuration value in Hex format		A
Switch pressed	1nF XX	Displays 8-bit market info value in Hex format.	\$31 = USA \$2A = Canada	B
Switch pressed (3 times)	cYL XX through tF	N/A		C
Switch pressed	ot1 XX	Displays oil pressure tell-tale "" in Hex format.		D
Switch pressed	ot0 XX	Displays oil pressure tell-tale "" in Hex format.		D
Switch pressed	XXXXX	"Corrected" speed value in hundredths of MPH. Gauge indication may be slightly higher. This is normal.	Will display "----" if message is not received. Will display "99999" if data received is invalid.	E
Switch pressed	XXXXX	"Corrected" speed value in hundredths of KPH. Gauge indication may be slightly different. This is normal.	Will display "----" if message is not received. Will display "99999" if data received is invalid.	F
Switch pressed	t XXXX	Tachometer value in RPM. Gauge indication may be higher at higher RPM. This is normal.	Will display "----" if message is not received.	H
Switch pressed	F1XXXX	Present fuel level A/D input. This input represents fuel sender input.	000-009 = Short circuit 010-254 = Normal range 255 = Open circuit	I
Switch pressed	F2XXX	Present FLPS.	010-254 = Normal range	J
Switch pressed	XXXC	Last temperature gauge input value in degrees C. Temperature gauge indicates present temperature per indication standard.	Will display "---"C if message is not received. Will display "999" if data received is invalid. High = 130 deg C Normal = 70 - 105 deg C Low = less than 50 deg C	K
Switch pressed	BAtXX.X	Estimated present battery voltage.		L
Switch pressed	rES -X	Seat belt buckle switch LH status.	1= Buckled 0 = Unbuckled	M
Switch pressed (33 times)	PA -XX through PA1-XX	N/A		
Switch pressed	GAGE		Return to beginning of self-diagnosis cycle.	MWI

CONSULT-III Function (METER/M&A)

INFOID:000000004918054

CONSULT-III can display each diagnostic item using the diagnostic test modes shown following.

METER/M&A diagnosis mode	Description
SELF-DIAG RESULTS	Displays combination meter self-diagnosis results.
DATA MONITOR	Displays combination meter input/output data in real time.
CAN DIAG SUPPORT MNTR	The result of transmit/receive diagnosis of CAN communication can be read.

SELF-DIAG RESULTS

Display Item List

DIAGNOSIS SYSTEM (METER)

< FUNCTION DIAGNOSIS >

Refer to [MWI-62, "DTC Index"](#).

DATA MONITOR

Display Item List

X: Applicable

Display item [Unit]	MAIN SIGNALS	SELECTION FROM MENU	Description
SPEED METER [km/h] or [mph]	X	X	Displays the value of vehicle speed signal.
SPEED OUTPUT [km/h] or [mph]	X	X	Displays the value of vehicle speed signal, which is transmitted to each unit with CAN communication.
TACHO METER [rpm]	X	X	Displays the value of engine speed signal, which is input from ECM.
FUEL METER [lit.]	X	X	Displays the value, which processes a resistance signal from fuel gauge.
W TEMP METER [°C] or [°F]	X	X	Displays the value of engine coolant temperature signal, which is input from ECM.
ABS W/L [ON/OFF]		X	Displays [ON/OFF] condition of ABS warning lamp.
VDC/TCS IND [ON/OFF]		X	Displays [ON/OFF] condition of VDC OFF indicator lamp.
SLIP IND [ON/OFF]		X	Displays [ON/OFF] condition of SLIP indicator lamp.
BRAKE W/L [ON/OFF]		X	Displays [ON/OFF] condition of brake warning lamp.*
DOOR W/L [ON/OFF]		X	Displays [ON/OFF] condition of door warning lamp.
TRUNK W/L [ON/OFF]		X	Displays [ON/OFF] condition of glass hatch warning lamp.
HI-BEAM IND [ON/OFF]		X	Displays [ON/OFF] condition of high beam indicator.
TURN IND [ON/OFF]		X	Displays [ON/OFF] condition of turn indicator.
OIL W/L [ON/OFF]		X	Displays [ON/OFF] condition of oil pressure warning lamp.
C-ENG W/L [ON/OFF]		X	Displays [ON/OFF] condition of malfunction indicator lamp.
CRUISE IND [ON/OFF]		X	Displays [ON/OFF] condition of CRUISE indicator.
SET IND [ON/OFF]		X	Displays [ON/OFF] condition of SET indicator.
AT CHECK W/L [ON/OFF]		X	Displays [ON/OFF] condition of AT CHECK warning lamp.
FUEL W/L [ON/OFF]	X	X	Displays [ON/OFF] condition of low-fuel warning lamp.
AIR PRES W/L [ON/OFF]		X	Displays [ON/OFF] condition of tire pressure warning lamp.
KEY G/Y W/L [ON/OFF]		X	Displays [ON/OFF] condition of key green warning lamp.
KEY R W/L [ON/OFF]		X	Displays [ON/OFF] condition of key red warning lamp.
KEY KNOB W/L [ON/OFF]		X	Displays [ON/OFF] condition of key knob warning lamp.
M RANGE SW [ON/OFF]	X	X	Displays [ON/OFF] condition of manual mode range switch.
NM RANGE SW [ON/OFF]	X	X	Displays [ON/OFF] condition of except for manual mode range switch.
AT SFT UP SW [ON/OFF]	X	X	Displays [ON/OFF] condition of A/T shift-up switch.
AT SFT DWN SW [ON/OFF]	X	X	Displays [ON/OFF] condition of A/T shift-down switch.
DISTANCE [km] or [mile]	X	X	Displays the value, which is calculated by vehicle speed signal, fuel gauge and fuel consumption from ECM.
BUZZER [ON/OFF]	X	X	Displays [ON/OFF] condition of buzzer.
BRAKE SW [ON/OFF]		X	Indicates [ON/OFF] condition of parking brake switch.
AT-M GEAR [1, 2, 3, 4, 5]	X	X	Indicates [1, 2, 3, 4, 5] condition of A/T manual mode gear position.
P RANGE IND [ON/OFF]	X	X	Indicates [ON/OFF] condition of A/T shift P range indicator.
R RANGE IND [ON/OFF]	X	X	Indicates [ON/OFF] condition of A/T shift R range indicator.
N RANGE IND [ON/OFF]	X	X	Indicates [ON/OFF] condition of A/T shift N range indicator.
D RANGE IND [ON/OFF]	X	X	Indicates [ON/OFF] condition of A/T shift D range indicator.
4 RANGE IND [ON/OFF]	X	X	Indicates [ON/OFF] condition of A/T shift 4 range indicator.

DIAGNOSIS SYSTEM (METER)

< FUNCTION DIAGNOSIS >

Display item [Unit]	MAIN SIGNALS	SELECTION FROM MENU	Description
3 RANGE IND [ON/OFF]	X	X	Indicates [ON/OFF] condition of A/T shift 3 range indicator.
2 RANGE IND [ON/OFF]	X	X	Indicates [ON/OFF] condition of A/T shift 2 range indicator.
1 RANGE IND [ON/OFF]	X	X	Indicates [ON/OFF] condition of A/T shift 1 range indicator.
CRUISE W/L [ON/OFF]		X	Indicates [ON/OFF] condition of CRUISE warning lamp.
4WD LOCK SW [ON/OFF]		X	Indicates [ON/OFF] condition of 4WD lock switch.
4WD LOCK IND [ON/OFF]		X	Indicates [ON/OFF] condition of 4WD lock indicator.
SEAT BELT W/L [ON/OFF]		X	Indicates [ON/OFF] condition of seat belt warning lamp.

NOTE:

Some items are not available due to vehicle specification.

*: The monitor will indicate "OFF" even though the brake warning lamp is on if either of the following conditions exist.

- The parking brake is engaged
- The brake fluid level is low

A
B
C
D
E
F
G
H
I
J
K
L
M
O
P

MWI

DTC U1000 CAN COMMUNICATION

< COMPONENT DIAGNOSIS >

COMPONENT DIAGNOSIS

DTC U1000 CAN COMMUNICATION

DTC Logic

INFOID:000000004918055

DTC DETECTION LOGIC

DTC	CONSULT-III display	Detection condition
U1000	CAN COMM CIRC [U1000]	When combination meter is not receiving CAN communication signals for 2 seconds or more.

Diagnosis Procedure

INFOID:000000004918056

Symptom: Displays "CAN COMM CIRC [U1000]" as a self-diagnosis result of combination meter.

1. CHECK CAN COMMUNICATION

Select "SELF-DIAG RESULTS" mode for "METER/M&A" with CONSULT-III.

>> Go to "LAN system". Refer to [LAN-14. "Trouble Diagnosis Flow Chart"](#).

DTC B2205 VEHICLE SPEED CIRCUIT

< COMPONENT DIAGNOSIS >

DTC B2205 VEHICLE SPEED CIRCUIT

Description

INFOID:000000004918057

The ABS actuator and electric unit (control unit) provides a vehicle speed signal to the combination meter via CAN communication lines.

DTC Logic

INFOID:000000004918058

DTC	CONSULT-III display	Detection condition
B2205	VEHICLE SPEED CIRC [B2205]	Malfunction is detected when an erroneous speed signal is received for 2 seconds or more.

Diagnosis Procedure

INFOID:000000004918059

Symptom: Displays "VEHICLE SPEED CIRC [B2205]" as a self-diagnosis result of combination meter.

1. CHECK COMBINATION METER INPUT SIGNAL

1. Start engine and select "METER/M&A" on CONSULT-III.
2. Using "SPEED METER" on "DATA MONITOR", compare the value of DATA MONITOR with speedometer pointer of combination meter. Speedometer and DATA MONITOR indications should be close.

Is the inspection result normal?

- YES >> Perform ABS actuator and electric unit (control unit) self-diagnosis. Refer to [BRC-23. "CONSULT-III Function \(ABS\)".](#)
- NO >> Replace combination meter. Refer to [MWI-106. "Removal and Installation".](#)

A
B
C
D
E
F
G
H
I
J
K
L
M
O
P

MWI

POWER SUPPLY AND GROUND CIRCUIT

< COMPONENT DIAGNOSIS >

POWER SUPPLY AND GROUND CIRCUIT COMBINATION METER

COMBINATION METER : Diagnosis Procedure

INFOID:000000004918060

Regarding Wiring Diagram information, refer to [MWI-45. "Wiring Diagram"](#).

1. CHECK FUSES

Check for blown combination meter fuses.

Unit	Power source	Fuse No.
Combination meter	Battery	3
	Ignition switch ON or START	14
	Ignition switch ACC or ON	4

Is the inspection result normal?

YES >> GO TO 2

NO >> If fuse is blown, be sure to eliminate cause of malfunction before installing new fuse.

2. POWER SUPPLY CIRCUIT CHECK

1. Disconnect combination meter connector M24.
2. Check voltage between combination meter harness connector M24 terminals 1, 8, 24 and ground.

Terminals		(-)	Ignition switch position				
(+)	Connector		Terminal	OFF	ACC	ON	START
	M24	Ground	1	0V	Battery voltage	Battery voltage	0V
			8	Battery voltage	Battery voltage	Battery voltage	Battery voltage
			24	0V	0V	Battery voltage	Battery voltage

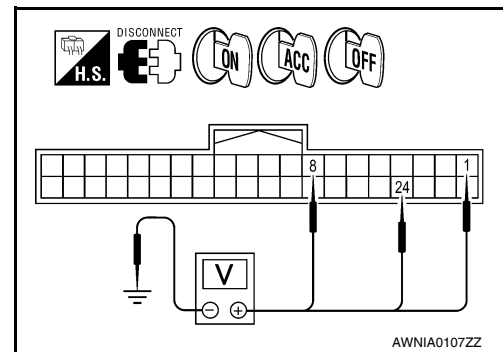

Is the inspection result normal?

YES >> GO TO 3

NO >> Check harness for open between combination meter and fuse.

3. GROUND CIRCUIT CHECK

1. Turn ignition switch OFF.
2. Disconnect combination meter connector M23.
3. Check continuity between combination meter harness connector M23 terminal 52 and ground, and connector M24 terminal 9 and ground.

Terminals		(-)	Continuity
(+)	Connector		
	A: M23	Ground	Yes
	B: M24		

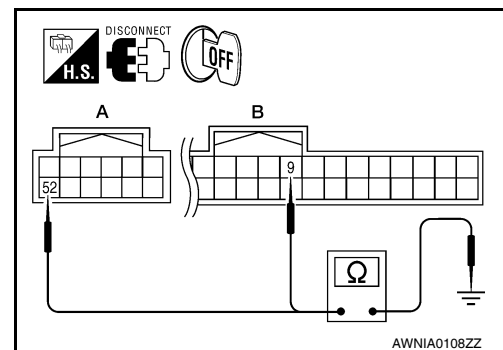

Is the inspection result normal?

YES >> Inspection End.

POWER SUPPLY AND GROUND CIRCUIT

< COMPONENT DIAGNOSIS >

NO >> Check ground harness.

BCM (BODY CONTROL MODULE)

BCM (BODY CONTROL MODULE) : Diagnosis Procedure

INFOID:000000005267107

Regarding Wiring Diagram information, refer to [BCS-50. "Wiring Diagram"](#).

1. CHECK FUSES AND FUSIBLE LINK

Check that the following fuses and fusible link are not blown.

Terminal No.	Signal name	Fuses and fusible link No.
57	Battery power supply	22 (15A)
70		F (50A)
11	Ignition ACC or ON	4 (10A)
38	Ignition ON or START	59 (10A)

Is the fuse blown?

YES >> Replace the blown fuse or fusible link after repairing the affected circuit.

NO >> GO TO 2

2. CHECK POWER SUPPLY CIRCUIT

1. Turn ignition switch OFF.
2. Disconnect BCM.
3. Check voltage between BCM harness connector and ground.

Connector	Terminals		Power source	Condition	Voltage (V) (Approx.)
	(+)	(-)			
M18	11	Ground	ACC power supply	Ignition switch ACC or ON	Battery voltage
	38	Ground	Ignition power supply	Ignition switch ON or START	Battery voltage
M20	57	Ground	Battery power supply	Ignition switch OFF	Battery voltage
	70	Ground	Battery power supply	Ignition switch OFF	Battery voltage

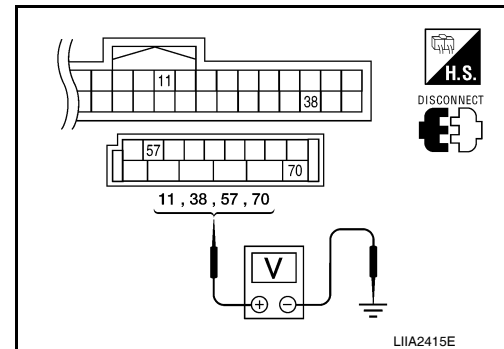

Is the measurement value normal?

YES >> GO TO 3

NO >> Repair or replace harness.

3. CHECK GROUND CIRCUIT

POWER SUPPLY AND GROUND CIRCUIT

< COMPONENT DIAGNOSIS >

Check continuity between BCM harness connector and ground.

BCM		Ground	Continuity
Connector	Terminal		
M20	67		Yes

Does continuity exist?

- YES >> Inspection End.
 NO >> Repair or replace harness.

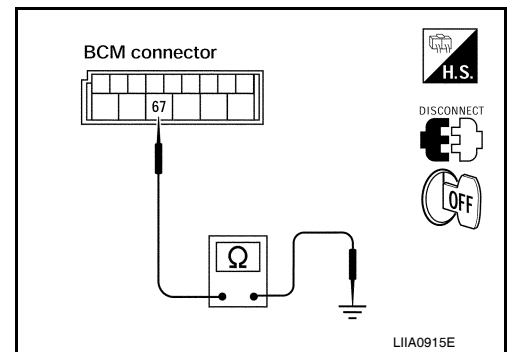

IPDM E/R (INTELLIGENT POWER DISTRIBUTION MODULE ENGINE ROOM)

IPDM E/R (INTELLIGENT POWER DISTRIBUTION MODULE ENGINE ROOM) : Diagnosis Procedure

INFOID:000000005267108

Regarding Wiring Diagram information, refer to [PCS-24. "Wiring Diagram"](#).

1. CHECK FUSES AND FUSIBLE LINK

Check that the following IPDM E/R fuses or fusible link are not blown.

Terminal No.	Signal name	Fuses and fusible link No.
1	Battery	A, D
2	Battery	C
12	Ignition switch ON or START	59

Is the fuse blown?

- YES >> Replace the blown fuse or fusible link after repairing the affected circuit.
 NO >> GO TO 2

2. CHECK BATTERY POWER SUPPLY CIRCUIT

- Turn ignition switch OFF.
- Disconnect IPDM E/R.
- Check voltage between IPDM E/R harness connectors and ground.

Terminals		(-)	Ignition switch position		
(+)			OFF	ON	START
Connector	Terminal				
E118 (A)	1	Ground	Battery voltage	Battery voltage	Battery voltage
	2		Battery voltage	Battery voltage	Battery voltage
E119 (B)	12		0V	Battery voltage	Battery voltage

Is the measurement value normal?

- YES >> GO TO 3
 NO >> Repair or replace harness.

3. CHECK GROUND CIRCUIT

- Turn ignition switch OFF.

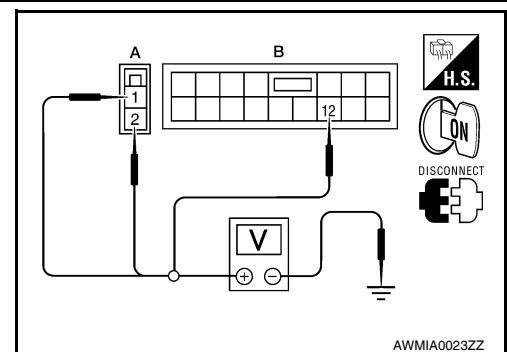

POWER SUPPLY AND GROUND CIRCUIT

< COMPONENT DIAGNOSIS >

- Check continuity between IPDM E/R harness connectors and ground.

IPDM E/R		Ground	Continuity
Connector	Terminal		
E122 (A)	38		Yes
E124 (B)	59		

Does continuity exist?

- YES >> Inspection End.
 NO >> Repair or replace harness.

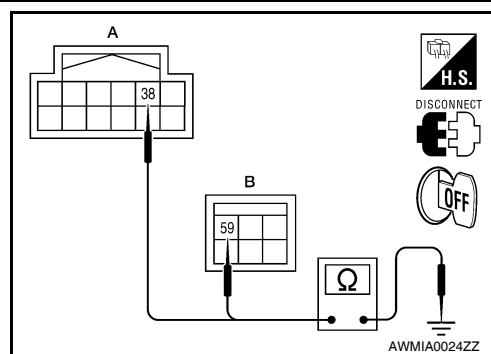

A
B
C
D
E
F
G
H
I
J
K
L
M

MWI

O
P

FUEL LEVEL SENSOR SIGNAL CIRCUIT

< COMPONENT DIAGNOSIS >

FUEL LEVEL SENSOR SIGNAL CIRCUIT

Description

INFOID:000000004918063

The fuel level sensor unit and fuel pump detects the approximate fuel level in the fuel tank and transmits the fuel level signal to the combination meter.

Component Function Check

INFOID:000000004918064

1.COMBINATION METER INPUT SIGNAL

1. Select "METER/M&A" on CONSULT-III.
2. Using "FUEL METER" of "DATA MONITOR", compare the value of DATA MONITOR with fuel gauge pointer of combination meter.

Fuel gauge pointer	Reference value of data monitor [lit.]
Full	Approx. 93
3/4	Approx. 73
1/2	Approx. 52
1/4	Approx. 30
Empty	Approx. 11

Does the data monitor value approximately match the fuel gauge indication?

YES >> Inspection End.

NO >> Replace combination meter. Refer to [MWI-106. "Removal and Installation"](#).

Diagnosis Procedure

INFOID:000000004918065

Regarding Wiring Diagram information, refer to [MWI-45. "Wiring Diagram"](#).

1.CHECK HARNESS CONNECTOR

1. Turn ignition switch OFF.
2. Check combination meter and fuel level sensor unit terminals (meter-side and harness-side) for poor connection.

Is the inspection result normal?

YES >> GO TO 2

NO >> Repair or replace terminals or connectors.

2.CHECK FUEL LEVEL SENSOR UNIT CIRCUIT

1. Disconnect combination meter connector and fuel level sensor unit connector.
2. Check continuity between combination meter harness connector (B) and fuel level sensor unit and fuel pump harness connector (A).

A		B		Continuity
Connector	Terminal	Connector	Terminal	
C5	2	M24	15	Yes

3. Check continuity between fuel level sensor unit and fuel pump harness connector (A) and ground.

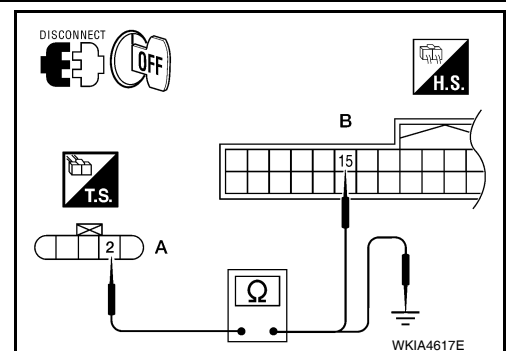

FUEL LEVEL SENSOR SIGNAL CIRCUIT

< COMPONENT DIAGNOSIS >

A		Ground	Continuity
Connector	Terminal		
C5	2		No

Is the inspection result normal?

YES >> GO TO 3

NO >> Repair harness or connector.

3. CHECK FUEL LEVEL SENSOR UNIT GROUND CIRCUIT

1. Check continuity between combination meter harness connector (B) and fuel level sensor unit and fuel pump harness connector (A).

A		B		Continuity
Connector	Terminal	Connector	Terminal	
C5	5	M24	16	Yes

2. Check continuity between fuel level sensor unit and fuel pump harness connector (A) and ground.

A		Ground	Continuity
Connector	Terminal		
C5	5		No

Is the inspection result normal?

YES >> GO TO 4

NO >> Repair harness or connector.

4. CHECK INSTALLATION CONDITION

Check fuel level sensor unit installation, and check whether the float arm interferes or binds with any of the internal components in the fuel tank.

Is the inspection result normal?

YES >> Inspection End.

NO >> Install the fuel level sensor unit properly.

Component Inspection

INFOID:000000004918066

1. REMOVE FUEL LEVEL SENSOR UNIT

Remove the fuel level sensor unit. Refer to [FL-12, "Removal and Installation"](#).

>> GO TO 2

2. CHECK FUEL LEVEL SENSOR UNIT AND FUEL PUMP

Check the resistance between terminals 2 and 5.

Terminal		Float position mm (in)		Resistance value (Approx.)
2	5	*1	Empty	7.5 (0.3)
		*2	Full	218.9 (8.6)

*1 and *2: When float arm is in contact with stopper.

Is inspection result normal?

YES >> Inspection End.

NO >> Replace fuel level sensor unit and fuel pump. Refer to [FL-12, "Removal and Installation"](#).

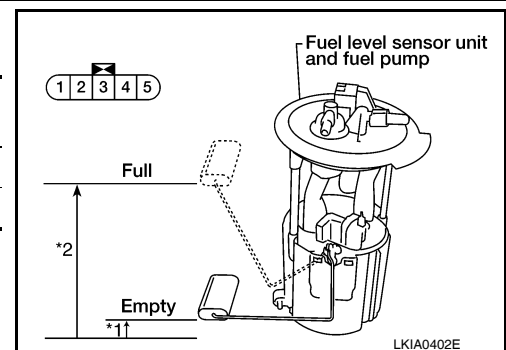
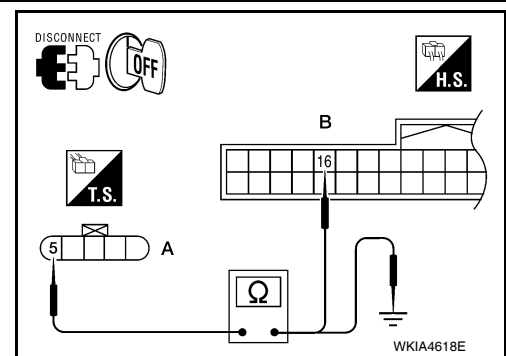

OIL PRESSURE SWITCH SIGNAL CIRCUIT

< COMPONENT DIAGNOSIS >

OIL PRESSURE SWITCH SIGNAL CIRCUIT

Description

INFOID:000000004918067

Detects the engine oil pressure and transmits the oil pressure switch signal to the IPDM E/R.

Component Function Check

INFOID:000000004918068

1.COMBINATION METER INPUT SIGNAL

1. Select "METER/M&A" on CONSULT-III.
2. Monitor "OIL W/L" of "DATA MONITOR" while operating ignition switch.

OIL W/L

When ignition switch is in ON : ON
position (Engine stopped)

When engine is running : OFF

>> Inspection End.

Diagnosis Procedure

INFOID:000000004918069

Regarding Wiring Diagram information, refer to [MWI-45. "Wiring Diagram"](#).

1.CHECK OIL PRESSURE SWITCH CIRCUIT

1. Turn ignition switch OFF.
2. Disconnect IPDM E/R connector E122 and oil pressure switch connector F4.
3. Check continuity between IPDM E/R harness connector E122 (A) terminal 42 and oil pressure switch harness connector F4 (B) terminal 1.

Continuity should exist.

Is the inspection result normal?

- YES >> Inspection End.
NO >> Repair harness or connector.

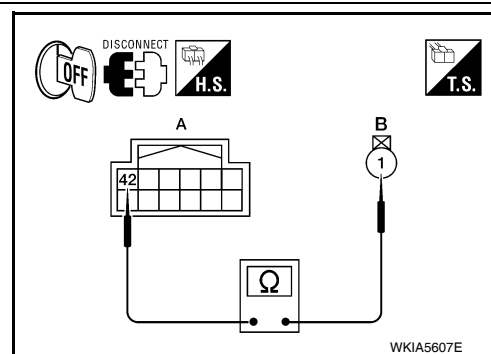

Component Inspection

INFOID:000000004918070

1.CHECK OIL PRESSURE SWITCH

Check continuity between oil pressure switch and ground.

Condition	Oil pressure [kPa (kg/cm ² , psi)]	Continuity
Engine stopped	Less than 29 (0.3, 4)	Yes
Engine running	More than 29 (0.3, 4)	No

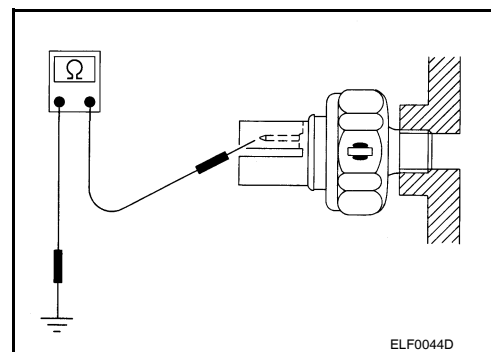

Is the inspection result normal?

- YES >> Inspection End.
NO >> Replace the oil pressure switch.

PARKING BRAKE SWITCH SIGNAL CIRCUIT

< COMPONENT DIAGNOSIS >

PARKING BRAKE SWITCH SIGNAL CIRCUIT

Description

INFOID:000000004918071

Transmits the parking brake switch signal to the combination meter.

Component Function Check

INFOID:000000004918072

1.COMBINATION METER INPUT SIGNAL

1. Start engine.
2. Monitor "BRAKE" warning lamp while applying and releasing the parking brake.

BRAKE warning lamp

Parking brake applied : ON

Parking brake released : OFF

>> Inspection End.

Diagnosis Procedure

INFOID:000000004918073

Regarding Wiring Diagram information, refer to [MWI-45, "Wiring Diagram"](#).

1.CHECK PARKING BRAKE SWITCH CIRCUIT

1. Disconnect combination meter connector and parking brake switch connector.
2. Check continuity between combination meter harness connector M24 (A) terminal 23 and parking brake switch harness connector M11 (B) terminal 1.

23 - 1 : Continuity should exist.

3. Check continuity between combination meter harness connector M24 (A) terminal 23 and ground.

23 - Ground : Continuity should not exist.

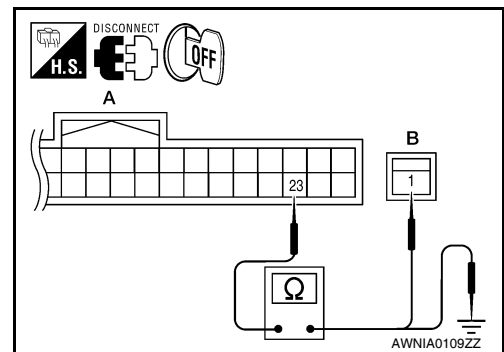

Is the inspection result normal?

- YES >> Inspection End.
 NO >> Repair harness or connector.

Component Inspection

INFOID:000000004918074

1.CHECK PARKING BRAKE SWITCH

Check continuity between parking brake switch terminal 1 and switch case ground.

Component	Terminal	Condition	Continuity
Parking brake switch	1	Parking brake applied	Yes
		Parking brake released	No

Is the inspection result normal?

- YES >> Inspection End.
 NO >> Replace parking brake switch.

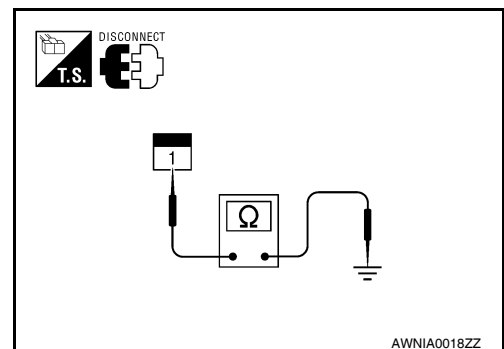

A
B
C
D
E
F
G
H
I
J
K
L
M
N
O
P

MWI

WASHER LEVEL SWITCH SIGNAL CIRCUIT

< COMPONENT DIAGNOSIS >

WASHER LEVEL SWITCH SIGNAL CIRCUIT

Description

INFOID:000000004918075

Transmits the washer level switch signal to the combination meter.

Diagnosis Procedure

INFOID:000000004918076

Regarding Wiring Diagram information, refer to [MWI-45, "Wiring Diagram"](#).

1. CHECK WASHER FLUID LEVEL SWITCH SIGNAL CIRCUIT

1. Turn ignition switch OFF.
2. Disconnect combination meter connector and washer fluid level switch connector.
3. Check continuity between combination meter harness connector M24 (A) terminal 37 and washer fluid level switch harness connector E106 (B) terminal 1.

37 - 1 : Continuity should exist.

4. Check continuity between combination meter harness connector M24 (A) terminal 37 and ground.

37 - Ground : Continuity should not exist.

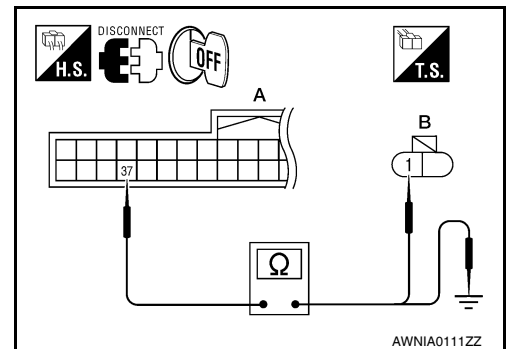

Is the inspection result normal?

YES >> GO TO 2

NO >> Repair harness or connector.

2. CHECK WASHER FLUID LEVEL SWITCH GROUND CIRCUIT

Check continuity between washer fluid level switch harness connector E106 terminal 2 and ground.

2 - Ground : Continuity should exist.

Is the inspection result normal?

YES >> Inspection End.

NO >> Repair harness or connector.

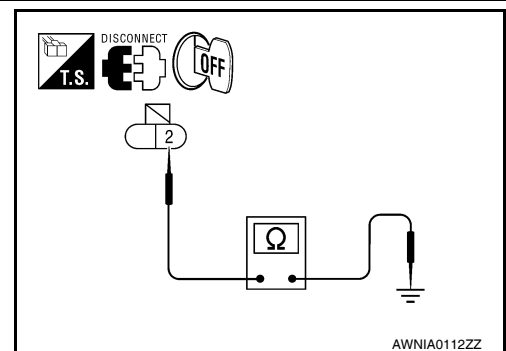

Component Inspection

INFOID:000000004918077

1. CHECK WASHER FLUID LEVEL SWITCH

Check continuity between washer fluid level switch terminals 1 and 2.

Terminal	Washer fluid level	Continuity
1 - 2	Low	Yes
	Other	No

Is the inspection result normal?

YES >> Inspection End.

NO >> Replace washer fluid level switch.

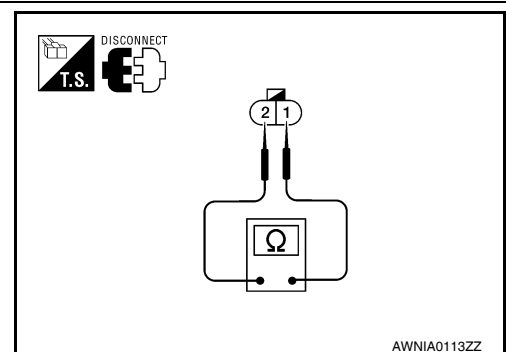

COMPASS

< COMPONENT DIAGNOSIS >

COMPASS

Wiring Diagram

INFOID:000000004918078

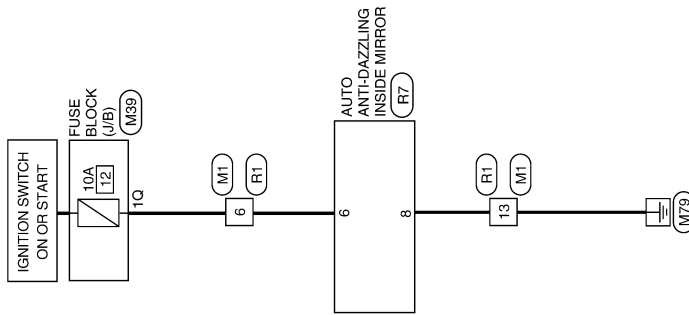

COMPASS

A
B
C
D
E
F
G
H
I
J
K
L
M
N
O
P

MWI

ALNWA0051GB

COMPASS CONNECTORS

Connector No.	M1
Connector Name	WIRE TO WIRE
Connector Color	WHITE

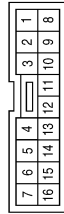

Terminal No.	Color of Wire	Signal Name
6	G/R	-
13	B	-

Connector No.	M39
Connector Name	FUSE BLOCK (J/B)
Connector Color	WHITE



Terminal No.	Color of Wire	Signal Name
1Q	G/R	-

Connector No.	R1
Connector Name	WIRE TO WIRE
Connector Color	WHITE

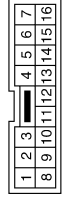

Terminal No.	Color of Wire	Signal Name
6	G/R	-
13	B	-

Connector No.	R7
Connector Name	AUTO ANTI-DAZZLING INSIDE MIRROR
Connector Color	GRAY

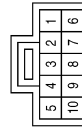

Terminal No.	Color of Wire	Signal Name
6	G/R	IGN
8	B	GND

ABNIA0170GB

COMBINATION METER

< ECU DIAGNOSIS >

ECU DIAGNOSIS

COMBINATION METER

Reference Value

INFOID:000000004918079

TERMINAL LAYOUT

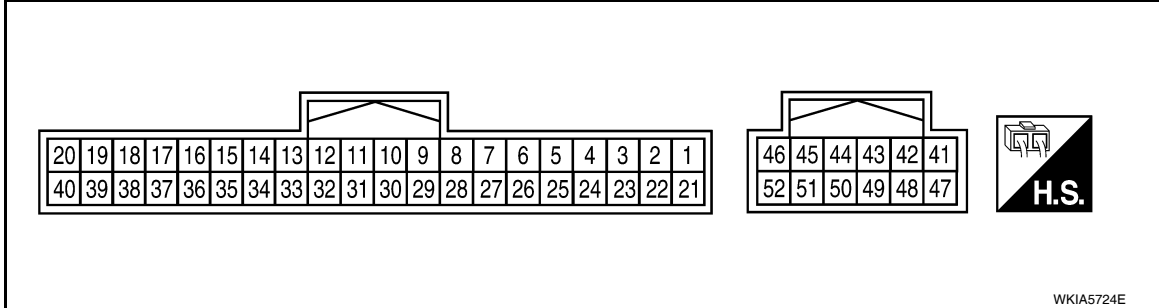

PHYSICAL VALUES

Terminal	Wire color	Item	Condition		Reference value (V) (Approx.)
			Ignition switch	Operation or condition	
1	O	Ignition switch ACC or ON	—	—	Battery voltage
2	P	Air bag warning lamp input	ON	Air bag warning lamp ON	4
				Air bag warning lamp OFF	0
3	BR	CK SUSP warning lamp input	—	CK SUSP warning lamp ON	0
				CK SUSP warning lamp OFF	Battery voltage
8	P	Battery power supply	—	—	Battery voltage
9	B	Ground	—	—	0
11	L	CAN-H	—	—	—
12	P	CAN-L	—	—	—
15	Y/L	Fuel level sensor signal	—	—	Refer to MWI-12, "FUEL GAUGE : System Description" .
16	B/P	Fuel level sensor ground	ON	—	0
18	P/B	Brake fluid level switch	ON	Brake fluid level low	0
				Brake fluid level normal	Battery voltage
23	G	Parking brake switch	ON	Parking brake applied	0
				Parking brake released	Battery voltage
24	O/L	Ignition switch ON or START	ON	—	Battery voltage
27	O/B	Seat belt buckle switch LH	ON	Unfastened (ON)	0
				Fastened (OFF)	Battery voltage
28	G/O	Security indicator input	OFF	Security indicator ON	0
				Security indicator OFF	Battery voltage

COMBINATION METER

< ECU DIAGNOSIS >

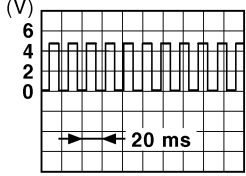
Terminal	Wire color	Item	Condition		Reference value (V) (Approx.)
			Ignition switch	Operation or condition	
29	W/R	Vehicle speed signal output (8-pulse)	ON	Speedometer operated [When vehicle speed is approx. 40 km/h (25 MPH)]	NOTE: Maximum voltage may be 12V due to specifications (connected units).  <small>PKIC0643E</small>
37	W/L	Washer fluid level switch	ON	Washer fluid level low	0
				Washer fluid level normal	Battery voltage
41	P/L	Seat belt buckle switch RH	ON	Unfastened (ON)	0
				Fastened (OFF)	Battery voltage
45	BR/W	Generator	ON	Generator voltage low	0
				Generator voltage normal	Battery voltage
50	BR	Illumination output	—	—	Refer to INL-9, "System Description" .
52	B	Ground	—	—	0

COMBINATION METER

< ECU DIAGNOSIS >

◁4W> : WITH 4-WHEEL DRIVE
 ◁LL> : WITH REAR LOAD LEVELING AIR SUSPENSION SYSTEM

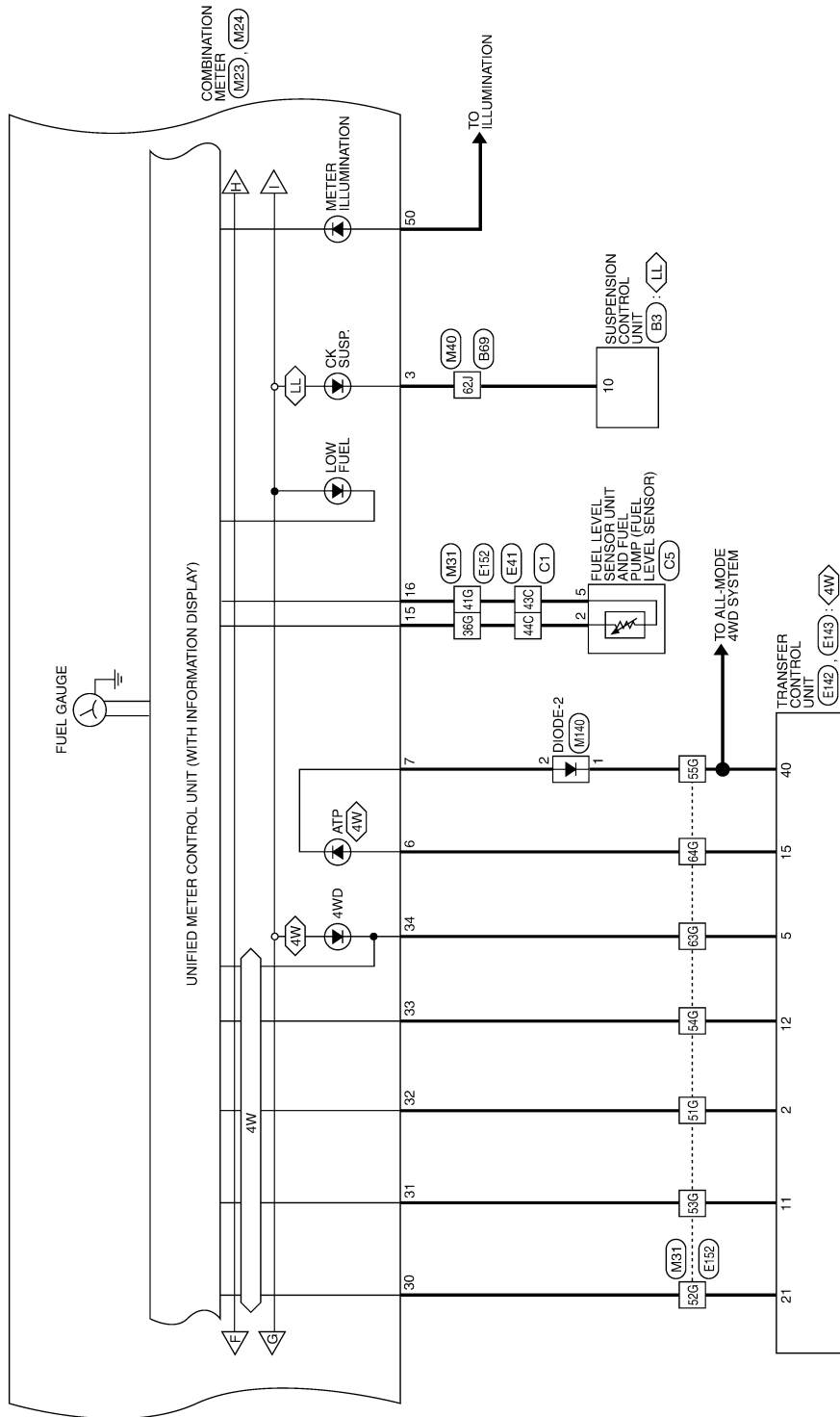

ABNWA0405GB

A
B
C
D
E
F
G
H
I
J
K
L
M
N
O
P

MWI

COMBINATION METER

< ECU DIAGNOSIS >

T7 : TRAILER TOW 7 PIN

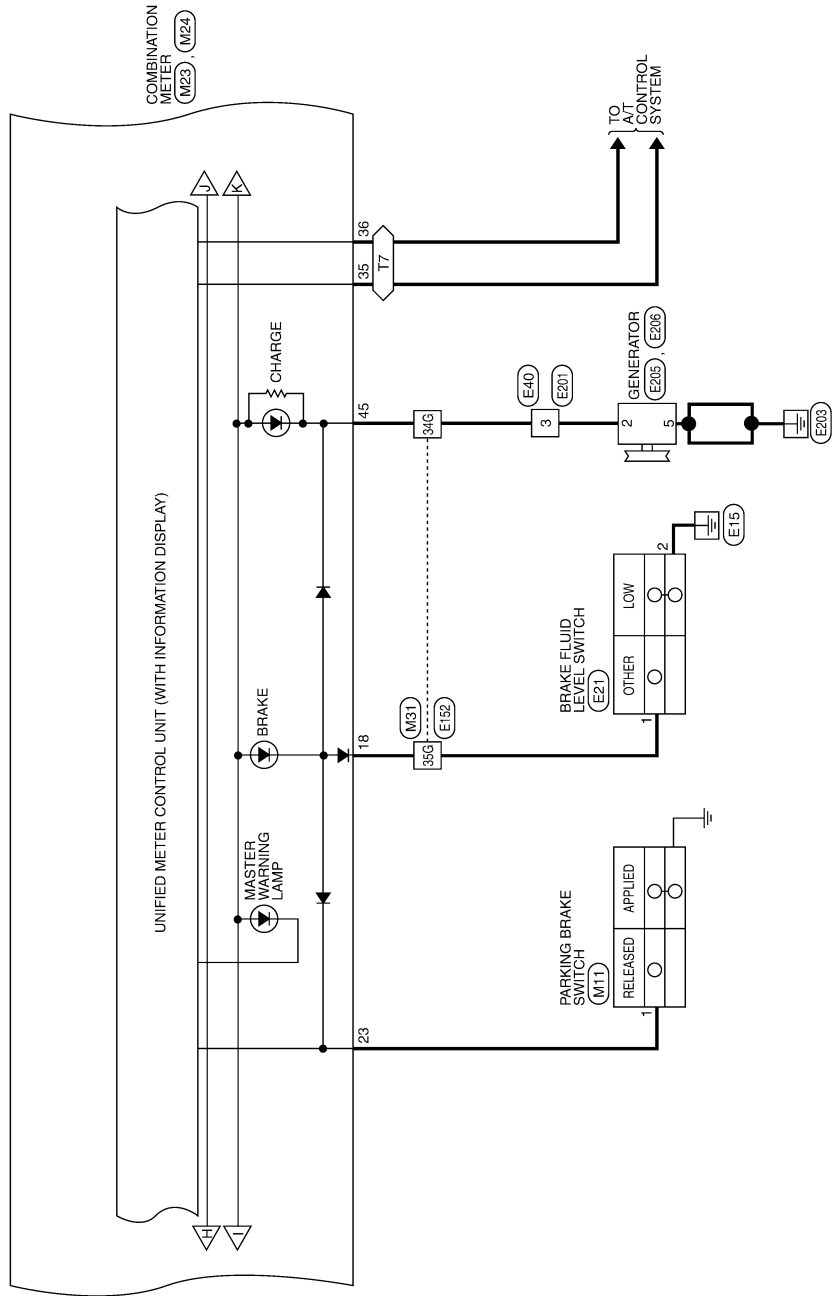

ABNWA0406GB

COMBINATION METER

< ECU DIAGNOSIS >

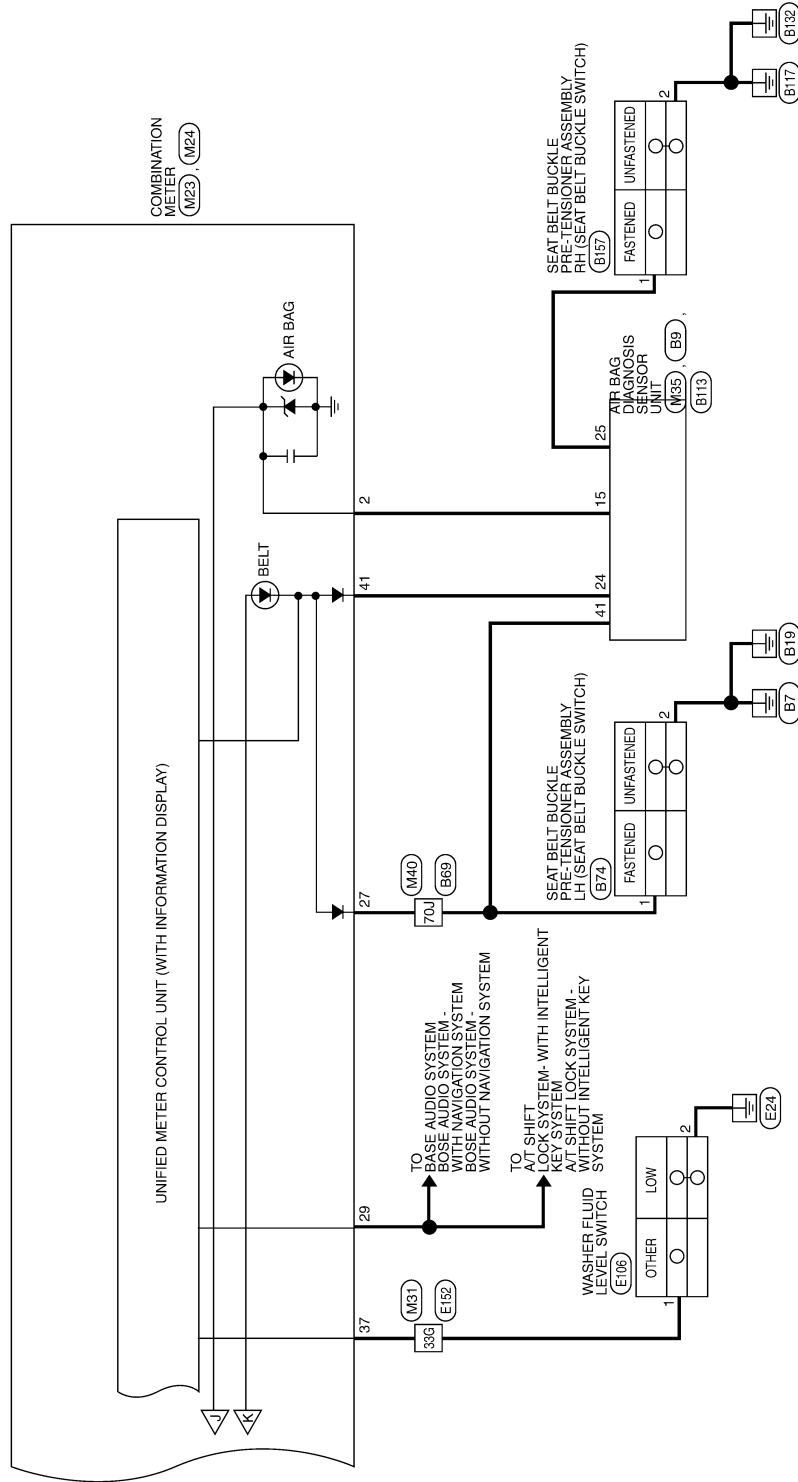

ABNWA0407GB

A
B
C
D
E
F
G
H
I
J
K
L
M
N
O
P

MWI

COMBINATION METER

< ECU DIAGNOSIS >

METER CONNECTORS

Connector No.	M4
Connector Name	FUSE BLOCK (J/B)
Connector Color	WHITE



Terminal No.	Color of Wire	Signal Name
5P	O/L	-
13P	P	-

Connector No.	M11
Connector Name	PARKING BRAKE SWITCH
Connector Color	BLACK



Terminal No.	Color of Wire	Signal Name
1	G	-

Connector No.	M18
Connector Name	BCM (BODY CONTROL MODULE)
Connector Color	WHITE

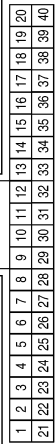

Terminal No.	Color of Wire	Signal Name
12	R/L	DOOR SW (AS)
13	GR	DOOR SW (RR)
23	G/O	SECURITY INDICATOR OUTPUT
39	L	CAN-H
40	P	CAN-L

Connector No.	M19
Connector Name	BCM (BODY CONTROL MODULE)
Connector Color	WHITE

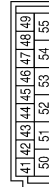

Terminal No.	Color of Wire	Signal Name
42	GR	GLASS HATCH SW
43	R/B	BACK DOOR SW
47	SB	DOOR SW (DR)
48	R/Y	DOOR SW (RL)

Connector No.	M23
Connector Name	COMBINATION METER
Connector Color	WHITE

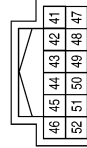

Terminal No.	Color of Wire	Signal Name
41	P/L	PASS SEAT BELT
42	-	-
43	-	-
44	-	-

Terminal No.	Color of Wire	Signal Name
45	BRAW	CHARGE IN
46	-	-
47	-	-
48	-	-
49	-	-
50	BR	ILL LED CON OUTPUT
51	-	-
52	B	ILL GND

COMBINATION METER

< ECU DIAGNOSIS >

Connector No.	M24
Connector Name	COMBINATION METER
Connector Color	WHITE

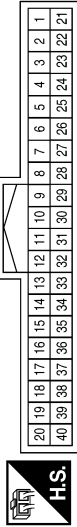

Terminal No.	Color of Wire	Signal Name
1	O	ACCESSORY
2	P	AIR BAG
3	BR	AIR LEVELIZER
4	Y/G	AT 1 RANGE
5	SB	AT 4 RANGE
6	L/B	ATP+
7	R/B	ATP-
8	P	BATTERY
9	B	GND
10	-	-

Terminal No.	Color of Wire	Signal Name
11	L	CAN-H
12	P	CAN-L
13	-	-
14	-	-
15	Y/L	FUEL IN
16	B/P	ANALOG GND
17	-	-
18	P/B	BRAKE FLUID
19	-	-
20	-	-
21	-	-
22	-	-
23	G	PARK BRAKE
24	O/L	RUN/START
25	-	-
26	-	-

Terminal No.	Color of Wire	Signal Name
27	O/B	SEATBELT
28	G/O	SECURITY
29	W/R	SPEED OUT
30	BR	TF AUTO
31	L	TF LOCK
32	B/W	TF 2WD
33	W/G	TF 4LO
34	W/B	TF 4WD
35	LG/R	TOW MODE
36	Y/V	TOW MODE LAMP
37	W/L	WASHER FLUID
38	-	-
39	B/R	PN ATCU
40	GR/R	PN REVERSE

Connector No.	M31
Connector Name	WIRE TO WIRE
Connector Color	WHITE

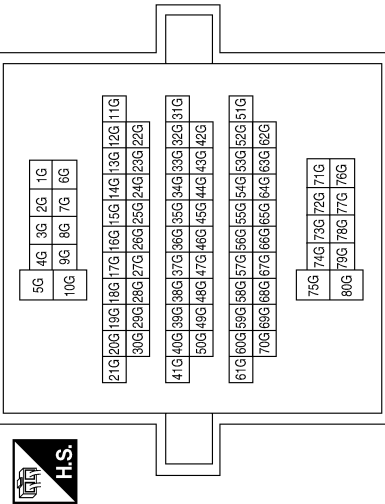

Terminal No.	Color of Wire	Signal Name
31G	L	-
33G	W/L	-
34G	BR/W	-
35G	P/B	-
36G	Y/L	-
41G	B/P	-
42G	P	-
51G	B/W	-
52G	BR	-
53G	L	-
54G	W/G	-
55G	L/Y	-

Terminal No.	Color of Wire	Signal Name
63G	W/B	-
64G	L/B	-

ABNIA1278GB

A
B
C
D
E
F
G
H
I
J
K
L
M
MWI
O
P

COMBINATION METER

< ECU DIAGNOSIS >

Connector No.	M35
Connector Name	AIR BAG DIAGNOSIS SENSOR UNIT
Connector Color	YELLOW

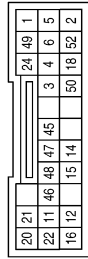

Terminal No.	Color of Wire	Signal Name
15	P	WARN LAMP
24	P/L	SEATBELT MINDER

Connector No.	M36
Connector Name	WIRE TO WIRE
Connector Color	WHITE

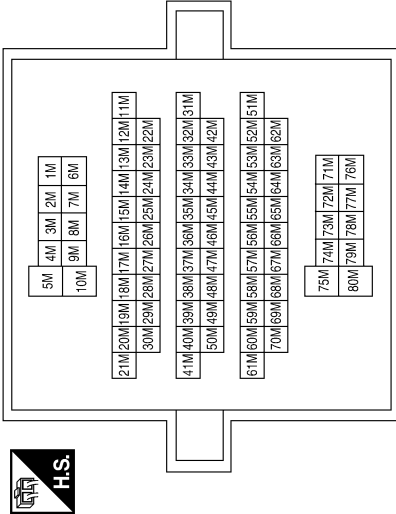

Terminal No.	Color of Wire	Signal Name
55M	GR	-
56M	GR	-
61M	R/L	-
65M	R/B	-

Connector No.	M40
Connector Name	WIRE TO WIRE
Connector Color	WHITE

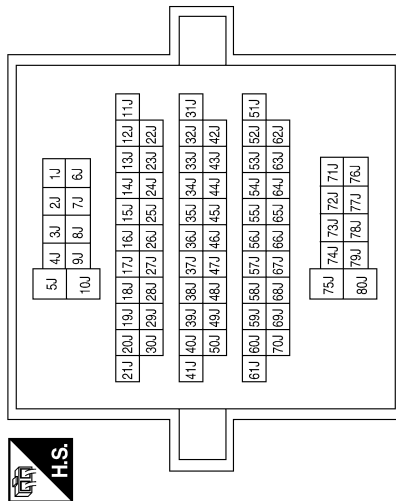

Terminal No.	Color of Wire	Signal Name
51J	L	-
52J	P	-
60J	SB	-
61J	R/Y	-
62J	BR	-
70J	O/B	-

Connector No.	M60
Connector Name	FUSE BLOCK (J/B)
Connector Color	WHITE

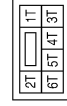

Terminal No.	Color of Wire	Signal Name
6T	O	-

ABNIA0041GB

COMBINATION METER

< ECU DIAGNOSIS >

Connector No.	E5
Connector Name	WIRE TO WIRE
Connector Color	WHITE

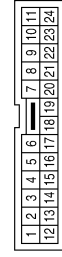

Terminal No.	Color of Wire	Signal Name
1	GR	-
3	L	-
5	L	-
14	P	-
15	P	-

Connector No.	M140
Connector Name	DIODE-2
Connector Color	BLACK



Terminal No.	Color of Wire	Signal Name
1	L/Y	-
2	R/B	-

Connector No.	M70
Connector Name	INTELLIGENT KEY UNIT
Connector Color	WHITE



Terminal No.	Color of Wire	Signal Name
2	L	CAN-H
3	P	CAN-L

Connector No.	E34
Connector Name	WIRE TO WIRE
Connector Color	WHITE

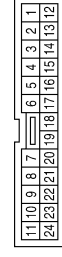

Terminal No.	Color of Wire	Signal Name
23	P	-
24	L	-

Connector No.	E21
Connector Name	BRAKE FLUID LEVEL SWITCH
Connector Color	GRAY



Terminal No.	Color of Wire	Signal Name
1	P/B	-
2	B	-

Connector No.	E16
Connector Name	ECM
Connector Color	BLACK

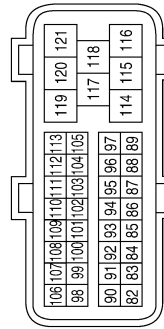

Terminal No.	Color of Wire	Signal Name
86	P	CAN-L
94	L	CAN-H

ABNIA1280GB

A
B
C
D
E
F
G
H
I
J
K
L
M
MWI
O
P

COMBINATION METER

< ECU DIAGNOSIS >

Connector No.	E40
Connector Name	WIRE TO WIRE
Connector Color	BLACK



Terminal No.	Color of Wire	Signal Name
3	BR/W	-

Connector No.	E41
Connector Name	WIRE TO WIRE
Connector Color	GRAY

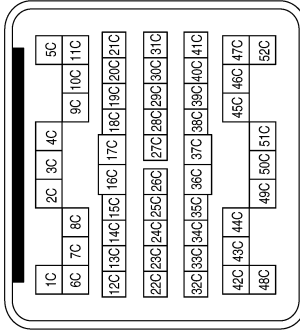

Terminal No.	Color of Wire	Signal Name
43C	B/P	-
44C	Y/L	-

Connector No.	E106
Connector Name	WASHER FLUID LEVEL SWITCH
Connector Color	BROWN



Terminal No.	Color of Wire	Signal Name
1	W/L	-
2	B	-

Connector No.	E122
Connector Name	IPDM E/R (INTELLIGENT POWER DISTRIBUTION MODULE ENGINE ROOM)
Connector Color	WHITE



Terminal No.	Color of Wire	Signal Name
38	B	GND (SIGNAL)
39	L	CAN-H
40	P	CAN-L
42	GR	OIL PRESSURE SW

Connector No.	E124
Connector Name	IPDM E/R (INTELLIGENT POWER DISTRIBUTION MODULE ENGINE ROOM)
Connector Color	BLACK



Terminal No.	Color of Wire	Signal Name
59	B	GND (POWER)

Connector No.	E125
Connector Name	ABS ACTUATOR AND ELECTRIC UNIT (CONTROL UNIT)
Connector Color	BLACK

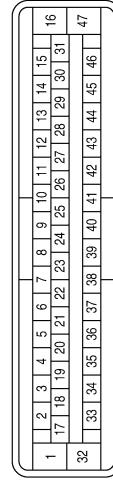

Terminal No.	Color of Wire	Signal Name
11	L	CAN-H
15	P	CAN-L

COMBINATION METER

< ECU DIAGNOSIS >

Connector No.	E142
Connector Name	TRANSFER CONTROL UNIT
Connector Color	WHITE

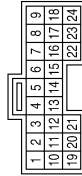

Terminal No.	Color of Wire	Signal Name
2	B/W	2WD IND
5	W/B	ETS FAIL
11	L	LOCK IND
12	W/G	4LO IND
15	L/B	ATP IND
21	BR	AUTO IND

Connector No.	E143
Connector Name	TRANSFER CONTROL UNIT
Connector Color	GRAY

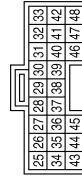

Terminal No.	Color of Wire	Signal Name
40	L/Y	ATP SW

Connector No.	E152
Connector Name	WIRE TO WIRE
Connector Color	WHITE

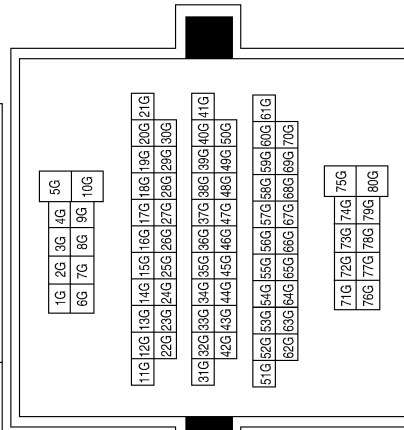

Terminal No.	Color of Wire	Signal Name
31G	L	-
33G	W/L	-
34G	BR/W	-
35G	P/B	-
36G	Y/L	-
41G	B/P	-
42G	P	-
51G	B/W	-
52G	BR	-
53G	L	-
54G	W/G	-
55G	L/Y	-
63G	W/B	-
64G	L/B	-

Connector No.	E201
Connector Name	WIRE TO WIRE
Connector Color	BLACK



Terminal No.	Color of Wire	Signal Name
3	BR/W	-

ABNIA1282GB

A
B
C
D
E
F
G
H
I
J
K
L
M
N
O
P

MWI

COMBINATION METER

< ECU DIAGNOSIS >

Connector No.	F4
Connector Name	OIL PRESSURE SWITCH
Connector Color	GRAY



Terminal No.	Color of Wire	Signal Name
1	GR	-

Connector No.	E206
Connector Name	GENERATOR
Connector Color	-



Terminal No.	Color of Wire	Signal Name
5	B	-

Connector No.	E205
Connector Name	GENERATOR
Connector Color	BLACK



Terminal No.	Color of Wire	Signal Name
2	BR/W	-

Connector No.	F502
Connector Name	TCM (TRANSMISSION CONTROL MODULE)
Connector Color	GRAY

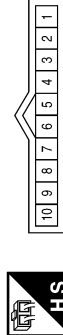

Terminal No.	Color of Wire	Signal Name
1	BR	CAN-H
2	L/Y	CAN-L
3	W/Y	ATF SENS 2-
5	W/R	ATF SENS 2+

Connector No.	F14
Connector Name	WIRE TO WIRE
Connector Color	WHITE

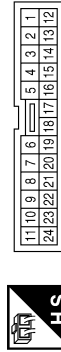

Terminal No.	Color of Wire	Signal Name
1	GR	-
3	L	-
5	L	-
14	P	-
15	P	-

Connector No.	F9
Connector Name	A/T ASSEMBLY
Connector Color	GREEN



Terminal No.	Color of Wire	Signal Name
3	L	-
8	P	-

ABNIA1283GB

COMBINATION METER

< ECU DIAGNOSIS >

Connector No.	F507
Connector Name	AT FLUID TEMPERATURE SENSOR-2
Connector Color	WHITE



Terminal No.	Color of Wire	Signal Name
1	W/Y	-
2	W/R	-

Connector No.	F505
Connector Name	TRANSMISSION RANGE SWITCH
Connector Color	GRAY



Terminal No.	Color of Wire	Signal Name
1	BR	S1
2	W	S4
3	GR	S2
5	L	S3
6	G	-
7	O	-

Connector No.	F503
Connector Name	TCM (TRANSMISSION CONTROL MODULE)
Connector Color	GREEN



Terminal No.	Color of Wire	Signal Name
11	W	INH-SW4
12	GR	INH-SW2
13	BR	INH-SW1
14	L	INH-SW3
18	O	ATF SENS 1-
19	G	ATF SENS 1+

Connector No.	B3
Connector Name	SUSPENSION CONTROL UNIT
Connector Color	WHITE

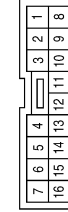

Terminal No.	Color of Wire	Signal Name
10	BR	WARNING LAMP OUTPUT

Connector No.	C5
Connector Name	FUEL LEVEL SENSOR UNIT AND FUEL PUMP
Connector Color	GRAY

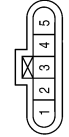

Terminal No.	Color of Wire	Signal Name
2	Y/L	-
5	B/P	-

Connector No.	C1
Connector Name	WIRE TO WIRE
Connector Color	GRAY

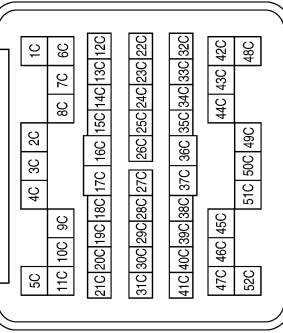

Terminal No.	Color of Wire	Signal Name
43C	B/P	-
44C	Y/L	-

ABN1A1284GB

A B C D E F G H I J K L M N O P



COMBINATION METER

< ECU DIAGNOSIS >

Connector No.	B8
Connector Name	FRONT DOOR SWITCH LH
Connector Color	WHITE

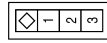

Terminal No.	Color of Wire	Signal Name
2	SB	-

Connector No.	B9
Connector Name	AIR BAG DIAGNOSIS SENSOR UNIT
Connector Color	YELLOW

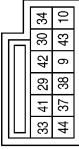

Terminal No.	Color of Wire	Signal Name
41	O/B	BUCKLE SW LH

Connector No.	B18
Connector Name	REAR DOOR SWITCH LH
Connector Color	WHITE

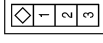

Terminal No.	Color of Wire	Signal Name
2	R/Y	-

Connector No.	B40
Connector Name	WIRE TO WIRE
Connector Color	WHITE

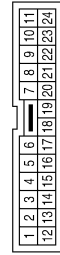

Terminal No.	Color of Wire	Signal Name
23	P	-
24	L	-

Connector No.	B43
Connector Name	WIRE TO WIRE
Connector Color	WHITE

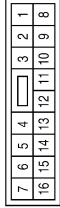

Terminal No.	Color of Wire	Signal Name
10	R/W	-

Connector No.	B48
Connector Name	WIRE TO WIRE
Connector Color	WHITE

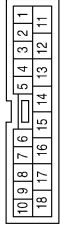

Terminal No.	Color of Wire	Signal Name
14	B	-
15	R/W	-

COMBINATION METER

< ECU DIAGNOSIS >

Connector No.	B69
Connector Name	WIRE TO WIRE
Connector Color	WHITE

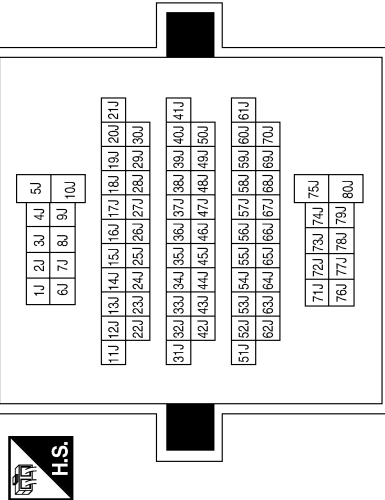

Connector No.	B74
Connector Name	SEAT BELT BUCKLE PRE-TENSIONER ASSEMBLY LH
Connector Color	YELLOW



Terminal No.	Color of Wire	Signal Name
1	O/B	-
2	B	-

Connector No.	B108
Connector Name	FRONT DOOR SWITCH RH
Connector Color	WHITE



Terminal No.	Color of Wire	Signal Name
2	R/L	-

Terminal No.	Color of Wire	Signal Name
51J	L	-
52J	P	-
60J	SB	-
61J	R/Y	-
62J	BR	-
70J	O/B	-

Connector No.	B111
Connector Name	WIRE TO WIRE
Connector Color	WHITE

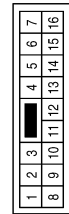

Terminal No.	Color of Wire	Signal Name
10	R/W	-

Connector No.	B113
Connector Name	AIR BAG DIAGNOSIS SENSOR UNIT
Connector Color	YELLOW

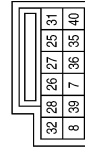

Terminal No.	Color of Wire	Signal Name
25	L	BUCKLE SW RH

Connector No.	B116
Connector Name	REAR DOOR SWITCH RH
Connector Color	WHITE

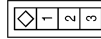

Terminal No.	Color of Wire	Signal Name
2	GR	-

ABNIA1286GB

A B C D E F G H I J K L M MWI O P

COMBINATION METER

< ECU DIAGNOSIS >

Connector No.	B157
Connector Name	SEAT BELT BUCKLE PRE-TENSIONER ASSEMBLY RH
Connector Color	YELLOW

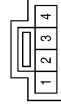

Terminal No.	Color of Wire	Signal Name
1	L	-
2	B	-

Connector No.	B149
Connector Name	WIRE TO WIRE
Connector Color	WHITE

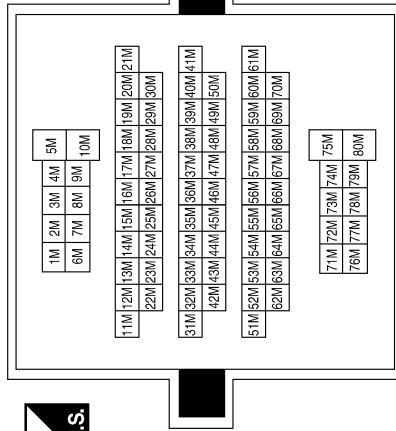

Terminal No.	Color of Wire	Signal Name
55M	GR	-
56M	GR	-
61M	R/L	-
65M	R/W	-

Connector No.	B139
Connector Name	WIRE TO WIRE
Connector Color	WHITE

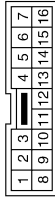

Terminal No.	Color of Wire	Signal Name
13	GR	-

Connector No.	D501
Connector Name	WIRE TO WIRE
Connector Color	WHITE

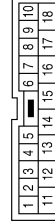

Connector No.	D405
Connector Name	WIRE TO WIRE
Connector Color	WHITE



Connector No.	D401
Connector Name	WIRE TO WIRE
Connector Color	WHITE



Terminal No.	Color of Wire	Signal Name
14	B	-
15	R/W	-

Terminal No.	Color of Wire	Signal Name
14	B	-
15	R/W	-

Terminal No.	Color of Wire	Signal Name
14	B	-
15	R/W	-

ABNIA1287GB

COMBINATION METER

< ECU DIAGNOSIS >

Connector No.	D602
Connector Name	WIRE TO WIRE
Connector Color	WHITE

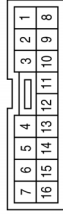

Terminal No.	13	Color of Wire	GR	Signal Name	-
--------------	----	---------------	----	-------------	---

Connector No.	D503
Connector Name	BACK DOOR LATCH
Connector Color	WHITE

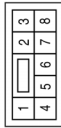

Terminal No.	7	Color of Wire	R/W	Signal Name	-
8	B	B	-	-	

Connector No.	D502
Connector Name	BACK DOOR SWITCH
Connector Color	WHITE



Terminal No.	1	Color of Wire	B	Signal Name	-
3	R/W	R/W	-	-	

Connector No.	D707
Connector Name	GLASS HATCH AJAR SWITCH
Connector Color	BLACK



Terminal No.	1	Color of Wire	GR	Signal Name	-
--------------	---	---------------	----	-------------	---

Connector No.	D701
Connector Name	WIRE TO WIRE
Connector Color	WHITE



Terminal No.	13	Color of Wire	GR	Signal Name	-
--------------	----	---------------	----	-------------	---

Connector No.	D606
Connector Name	WIRE TO WIRE
Connector Color	WHITE

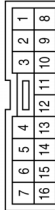

Terminal No.	13	Color of Wire	GR	Signal Name	-
--------------	----	---------------	----	-------------	---

Fail Safe

The combination meter performs a fail-safe operation for the functions listed below when communication is lost.

ABNIA1288GB

INFOID:000000004918081

A
B
C
D
E
F
G
H
I
J
K
L
M
N
O
P

MWI

COMBINATION METER

< ECU DIAGNOSIS >

Function		Specifications
Speedometer		Zero indication.
Tachometer		
Fuel gauge		
Engine coolant temperature gauge		
Engine oil pressure gauge		
Voltage gauge		
A/T oil temperature gauge		
Illumination control	Meter illumination	Change to nighttime mode when communication is lost.
Segment LCD	Odometer	Freeze current indication.
	A/T position	Display turns off.
Buzzer		Buzzer turns off.
Warning lamp/indicator lamp	ABS warning lamp	Lamp turns on when communication is lost.
	Brake warning lamp	
	VDC OFF indicator lamp	
	SLIP indicator lamp	
	A/T CHECK warning lamp	Lamp turns off when communication is lost.
	Oil pressure/coolant temperature warning lamp	
	Malfunction indicator lamp	
	Master warning lamp	
	Air bag warning lamp	
	High beam indicator	Lamp turns off when disconnected.
	Turn signal indicator lamp	
	Intelligent Key system warning lamp	
	Driver and passenger seat belt warning lamp	
	Charge warning lamp	
	Security indicator lamp	
	4WD indicator lamp	
	ATP indicator lamp	
CK SUSP warning lamp	Lamp will flash every second for 1 minute and then stay on continuously thereafter.	
Low tire pressure warning lamp		

DTC Index

INFOID:000000004918082

CONSULT-III display	Malfunction	Reference page
CAN COMM CIRC [U1000]	Malfunction is detected in CAN communication. CAUTION: Even when there is no malfunction on CAN communication system, malfunction may be misinterpreted when battery has low voltage (when maintaining 7 - 8 V for about 2 seconds) or 10A fuse [No. 3, located in the fuse block (J/B)] is disconnected.	MWI-30
VEHICLE SPEED CIRC [B2205]	Malfunction is detected when an erroneous speed signal is input. CAUTION: Even when there is no malfunction on speed signal system, malfunction may be misinterpreted when battery has low voltage (when maintaining 7 - 8 V for about 2 seconds).	MWI-31

NOTE:

COMBINATION METER

< ECU DIAGNOSIS >

“TIME” indicates the following.

- 0: Indicates that a malfunction is detected at present.
- 1-63: Indicates that a malfunction was detected in the past. (Displays number of ignition switch OFF → ON cycles after malfunction is detected. Self-diagnosis result is erased when “63” is exceeded.)

A

B

C

D

E

F

G

H

I

J

K

L

M

MWI

O

P

BCM (BODY CONTROL MODULE)

< ECU DIAGNOSIS >

BCM (BODY CONTROL MODULE)

Reference Value

INFOID:000000005199722

VALUES ON THE DIAGNOSIS TOOL

Monitor Item	Condition	Value/Status
AIR COND SW	A/C switch OFF	OFF
	A/C switch ON	ON
AUT LIGHT SYS	Outside of the room is dark	OFF
	Outside of the room is bright	ON
AUTO LIGHT SW	Lighting switch OFF	OFF
	Lighting switch AUTO	ON
BACK DOOR SW	Back door closed	OFF
	Back door opened	ON
CARGO LAMP SW	Cargo lamp switch OFF	OFF
	Cargo lamp switch ON	ON
CDL LOCK SW	Door lock/unlock switch does not operate	OFF
	Press door lock/unlock switch to the LOCK side	ON
CDL UNLOCK SW	Door lock/unlock switch does not operate	OFF
	Press door lock/unlock switch to the UNLOCK side	ON
DOOR SW-AS	Front door RH closed	OFF
	Front door RH opened	ON
DOOR SW-DR	Front door LH closed	OFF
	Front door LH opened	ON
DOOR SW-RL	Rear door LH closed	OFF
	Rear door LH opened	ON
DOOR SW-RR	Rear door RH closed	OFF
	Rear door RH opened	ON
ENGINE RUN	Engine stopped	OFF
	Engine running	ON
FR FOG SW	Front fog lamp switch OFF	OFF
	Front fog lamp switch ON	ON
FR WASHER SW	Front washer switch OFF	OFF
	Front washer switch ON	ON
FR WIPER LOW	Front wiper switch OFF	OFF
	Front wiper switch LO	ON
FR WIPER HI	Front wiper switch OFF	OFF
	Front wiper switch HI	ON
FR WIPER INT	Front wiper switch OFF	OFF
	Front wiper switch INT	ON
FR WIPER STOP	Any position other than front wiper stop position	OFF
	Front wiper stop position	ON
HAZARD SW	When hazard switch is not pressed	OFF
	When hazard switch is pressed	ON

BCM (BODY CONTROL MODULE)

< ECU DIAGNOSIS >

Monitor Item	Condition	Value/Status	
LIGHT SW 1ST	Lighting switch OFF	OFF	A
	Lighting switch 1st	ON	
HEAD LAMP SW1	Headlamp switch OFF	OFF	B
	Headlamp switch 1st	ON	
HEAD LAMP SW2	Headlamp switch OFF	OFF	C
	Headlamp switch 1st	ON	
HI BEAM SW	High beam switch OFF	OFF	D
	High beam switch HI	ON	
IGN ON SW	Ignition switch OFF or ACC	OFF	E
	Ignition switch ON	ON	
IGN SW CAN	Ignition switch OFF or ACC	OFF	F
	Ignition switch ON	ON	
INT VOLUME	Wiper intermittent dial is in a dial position 1 - 7	1 - 7	F
I-KEY LOCK ¹	LOCK button of Intelligent Key is not pressed	OFF	G
	LOCK button of Intelligent Key is pressed	ON	
I-KEY UNLOCK ¹	UNLOCK button of Intelligent Key is not pressed	OFF	H
	UNLOCK button of Intelligent Key is pressed	ON	
KEY CYL LK-SW	Door key cylinder LOCK position	ON	I
	Door key cylinder other than LOCK position	OF	
KEY CYL UN-SW	Door key cylinder UNLOCK position	ON	J
	Door key cylinder other than UNLOCK position	ON	
KEY ON SW	Mechanical key is removed from key cylinder	OFF	K
	Mechanical key is inserted to key cylinder	ON	
KEYLESS LOCK ²	LOCK button of key fob is not pressed	OFF	L
	LOCK button of key fob is pressed	ON	
KEYLESS UNLOCK ²	UNLOCK button of key fob is not pressed	OFF	M
	UNLOCK button of key fob is pressed	ON	
OIL PRESS SW	<ul style="list-style-type: none"> • Ignition switch OFF or ACC • Engine running 	OFF	MWI
	Ignition switch ON	ON	
OPTICAL SENSOR	Bright outside of the vehicle	Close to 5V	O
	Dark outside of the vehicle	Close to 0V	
PASSING SW	Other than lighting switch PASS	OFF	P
	Lighting switch PASS	ON	
PUSH SW ¹	Return to ignition switch to LOCK position	OFF	
	Press ignition switch	ON	
REAR DEF SW	Rear window defogger switch OFF	OFF	
	Rear window defogger switch ON	ON	
RKE LCK-UNLCK	LOCK/UNLOCK buttons of key fob not pressed at same time	OFF	
	LOCK/UNLOCK buttons of key fob pressed at same time	ON	
RKE KEEP UNLK	UNLOCK button of key fob is not pressed	OFF	
	UNLOCK button of key fob is pressed	ON	
RR WASHER SW	Rear washer switch OFF	OFF	
	Rear washer switch ON	ON	

BCM (BODY CONTROL MODULE)

< ECU DIAGNOSIS >

Monitor Item	Condition	Value/Status
RR WIPER INT	Rear wiper switch OFF	OFF
	Rear wiper switch INT	ON
RR WIPER ON	Rear wiper switch OFF	OFF
	Rear wiper switch ON	ON
RR WIPER STOP	Rear wiper stop position	OFF
	Other than rear wiper stop position	ON
RR WIPER STP2	Rear wiper stop position	OFF
	Other than rear wiper stop position	ON
TRNK OPNR SW	When back door opener switch is not pressed	OFF
	When back door opener switch is pressed	ON
TURN SIGNAL L	Turn signal switch OFF	OFF
	Turn signal switch LH	ON
TURN SIGNAL R	Turn signal switch OFF	OFF
	Turn signal switch RH	ON
VEHICLE SPEED	While driving	Equivalent to speedometer reading

1: With Intelligent Key

2: With remote keyless entry system

BCM (BODY CONTROL MODULE)

< ECU DIAGNOSIS >

Terminal Layout

INFOID:000000005199723

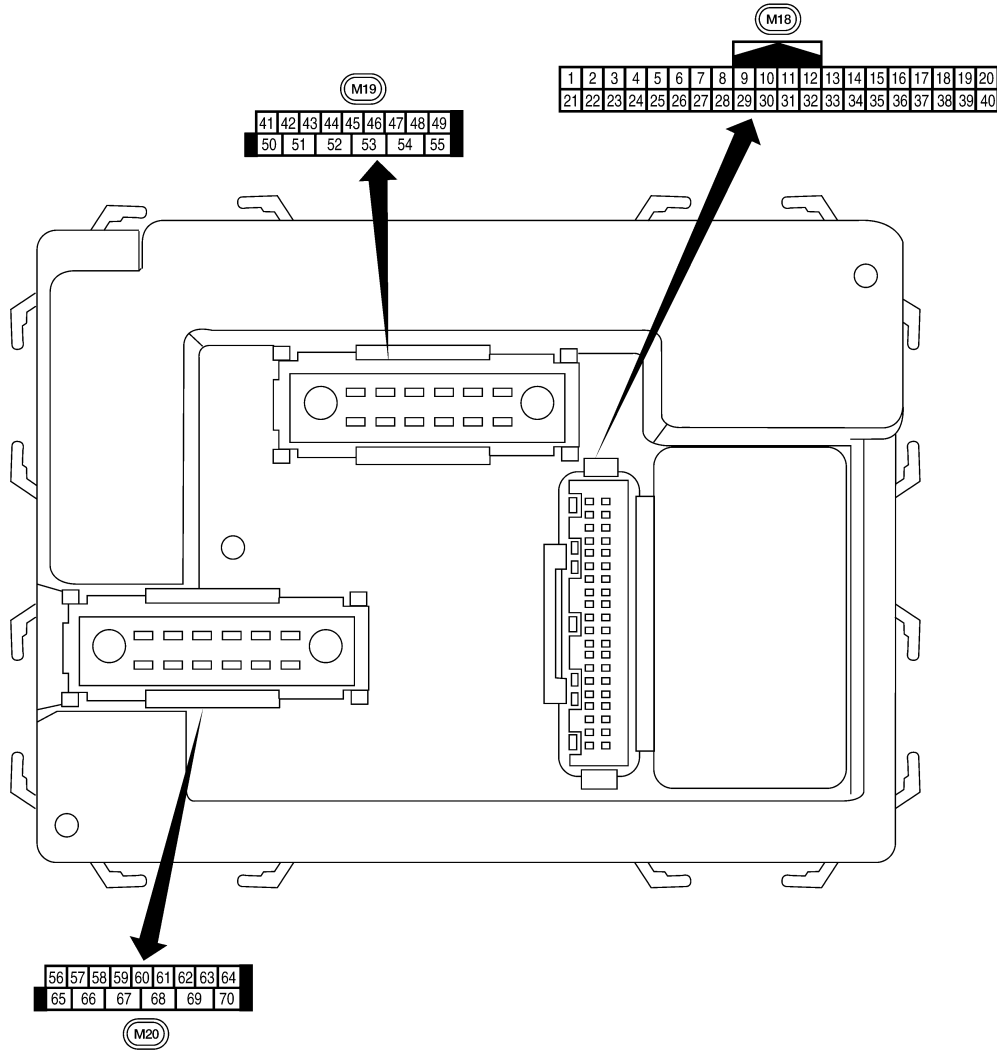

A
B
C
D
E
F
G
H
I
J
K
L
M

MWI



Physical Values

LIA2443E

INFOID:000000005199724

BCM (BODY CONTROL MODULE)

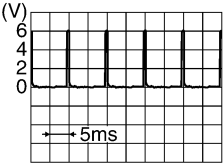
< ECU DIAGNOSIS >

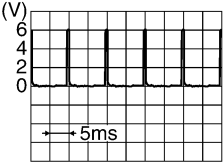
Terminal	Wire color	Signal name	Signal input/output	Measuring condition		Reference value or waveform (Approx.)
				Ignition switch	Operation or condition	
1	BR/W	Ignition keyhole illumination	Output	OFF	Door is locked (SW OFF)	Battery voltage
					Door is unlocked (SW ON)	0V
2	SB	Combination switch input 5	Input	ON	Lighting, turn, wiper OFF Wiper dial position 4	 <p style="text-align: right; font-size: small;">SKIA5291E</p>
3	G/Y	Combination switch input 4	Input	ON	Lighting, turn, wiper OFF Wiper dial position 4	 <p style="text-align: right; font-size: small;">SKIA5292E</p>
4	Y	Combination switch input 3	Input	ON	Lighting, turn, wiper OFF Wiper dial position 4	 <p style="text-align: right; font-size: small;">SKIA5291E</p>
5	G/B	Combination switch input 2	Input	ON	Lighting, turn, wiper OFF Wiper dial position 4	 <p style="text-align: right; font-size: small;">SKIA5292E</p>
6	V	Combination switch input 1				
9	GR/R	Rear window defogger switch	Input	ON	Rear window defogger switch ON	0V
					Rear window defogger switch OFF	5V
10	G	Hazard lamp flash	Input	OFF	ON (opening or closing)	0V
					OFF (other than above)	Battery voltage
11	O	Ignition switch (ACC or ON)	Input	ACC or ON	Ignition switch ACC or ON	Battery voltage
12	R/L	Front door switch RH	Input	OFF	ON (open)	0V
					OFF (closed)	Battery voltage
13	GR	Rear door switch RH	Input	OFF	ON (open)	0V
					OFF (closed)	Battery voltage
15	L/W	Tire pressure warning check connector	Input	OFF	—	5V
18	P	Remote keyless entry receiver and optical sensor (ground)	Output	OFF	—	0V

BCM (BODY CONTROL MODULE)

< ECU DIAGNOSIS >

Terminal	Wire color	Signal name	Signal input/output	Measuring condition		Reference value or waveform (Approx.)
				Ignition switch	Operation or condition	
19	V/W	Remote keyless entry receiver (power supply)	Output	OFF	Ignition switch OFF	<p style="text-align: right;">LIA1893E</p>
20	G/W	Remote keyless entry receiver (signal)	Input	OFF	Stand-by (keyfob buttons released)	<p style="text-align: right;">LIA1894E</p>
					When remote keyless entry receiver receives signal from keyfob (keyfob buttons pressed)	<p style="text-align: right;">LIA1895E</p>
21	G	NATS antenna amp.	Input	OFF → ON	Ignition switch (OFF → ON)	Just after turning ignition switch ON: Pointer of tester should move for approx. 1 second, then return to battery voltage.
22	W/V	BUS	—	—	Ignition switch ON or power window timer operates	<p style="text-align: right;">PIIA2344E</p>
23	G/O	Security indicator lamp	Output	OFF	Goes OFF → illuminates (Every 2.4 seconds)	Battery voltage → 0V
25	BR	NATS antenna amp.	Input	OFF → ON	Ignition switch (OFF → ON)	Just after turning ignition switch ON: Pointer of tester should move for approx. 1 second, then return to battery voltage.
26	Y/L	Rear wiper auto stop switch 2	Input	ON	Rise up position (rear wiper arm on stopper)	0V
					A Position (full clockwise stop position)	0V
					Forward sweep (counterclockwise direction)	Fluctuating
					B Position (full counterclockwise stop position)	Battery voltage
					Reverse sweep (clockwise direction)	Fluctuating
27	W/R	Compressor ON signal	Input	ON	A/C switch OFF	5V
					A/C switch ON	0V

A
B
C
D
E
F
G
H
I
J
K
L
M
N
O
P

MWI

BCM (BODY CONTROL MODULE)

< ECU DIAGNOSIS >

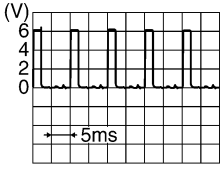
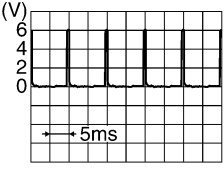
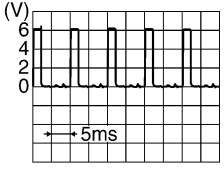
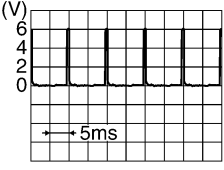
Terminal	Wire color	Signal name	Signal input/output	Measuring condition		Reference value or waveform (Approx.)
				Ignition switch	Operation or condition	
28	L/R	Front blower monitor	Input	ON	Front blower motor OFF	Battery voltage
					Front blower motor ON	0V
29	W/B	Hazard switch	Input	OFF	ON	0V
					OFF	5V
32	R/G	Combination switch output 5	Output	ON	Lighting, turn, wiper OFF Wiper dial position 4	 <p style="text-align: right; font-size: small;">SKIA5291E</p>
33	R/Y	Combination switch output 4	Output	ON	Lighting, turn, wiper OFF Wiper dial position 4	 <p style="text-align: right; font-size: small;">SKIA5292E</p>
34	L	Combination switch output 3	Output	ON	Lighting, turn, wiper OFF Wiper dial position 4	 <p style="text-align: right; font-size: small;">SKIA5291E</p>
35	O/B	Combination switch output 2	Output	ON	Lighting, turn, wiper OFF Wiper dial position 4	 <p style="text-align: right; font-size: small;">SKIA5292E</p>
36	R/W	Combination switch output 1				
37 ¹	B/R	Key switch and ignition knob switch	Input	OFF	Intelligent Key inserted	Battery voltage
					Intelligent Key inserted	0V
37 ²	B/R	Key switch and key lock solenoid	Input	OFF	Key inserted	Battery voltage
					Key inserted	0V
38	W/L	Ignition switch (ON)	Input	ON	—	Battery voltage
39	L	CAN-H	—	—	—	—
40	P	CAN-L	—	—	—	—
42	GR	Glass hatch ajar switch	Input	ON	Glass hatch open	0
					Glass hatch closed	Battery
43	R/B	Back door switch (without power back door) or back door latch (door ajar switch) (with power back door)	Input	OFF	ON (open)	0V
					OFF (closed)	Battery voltage

BCM (BODY CONTROL MODULE)

< ECU DIAGNOSIS >

Terminal	Wire color	Signal name	Signal input/output	Measuring condition		Reference value or waveform (Approx.)
				Ignition switch	Operation or condition	
44	O	Rear wiper auto stop switch 1	Input	ON	Rise up position (rear wiper arm on stopper)	0V
					A Position (full clockwise stop position)	Battery voltage
					Forward sweep (counterclockwise direction)	Fluctuating
					B Position (full counterclockwise stop position)	0V
					Reverse sweep (clockwise direction)	Fluctuating
47	SB	Front door switch LH	Input	OFF	ON (open)	0V
					OFF (closed)	Battery voltage
48	R/Y	Rear door switch LH	Input	OFF	ON (open)	0V
					OFF (closed)	Battery voltage
49	R	Cargo lamp	Output	OFF	Any door open (ON)	0V
					All doors closed (OFF)	Battery voltage
51	G/Y	Trailer turn signal (right)	Output	ON	Turn right ON	
52	G/B	Trailer turn signal (left)	Output	ON	Turn left ON	
54	Y	Rear wiper output circuit 2	Input	ON	Rise up position (rear wiper arm on stopper)	0V
					A Position (full clockwise stop position)	0V
					Forward sweep (counterclockwise direction)	0V
					B Position (full counterclockwise stop position)	Battery voltage
					Reverse sweep (clockwise direction)	Battery voltage
55	SB	Rear wiper output circuit 1	Output	ON	OFF	0
					ON	Battery voltage
56	R/G	Battery saver output	Output	OFF	30 minutes after ignition switch is turned OFF	0V
				ON	—	Battery voltage
57	Y/R	Battery power supply	Input	OFF	—	Battery voltage

A
B
C
D
E
F
G
H
I
J
K
L
M
MWI
O
P

BCM (BODY CONTROL MODULE)

< ECU DIAGNOSIS >

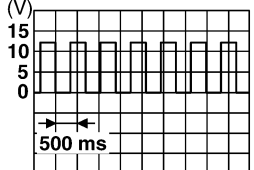
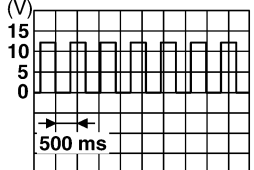
Terminal	Wire color	Signal name	Signal input/output	Measuring condition		Reference value or waveform (Approx.)
				Ignition switch	Operation or condition	
58	W/R	Optical sensor	Input	ON	When optical sensor is illuminated	3.1V or more
					When optical sensor is not illuminated	0.6V or less
59	G	Front door lock assembly LH actuator (unlock)	Output	OFF	OFF (neutral)	0V
					ON (unlock)	Battery voltage
60	G/B	Turn signal (left)	Output	ON	Turn left ON	 <p style="text-align: right; font-size: small;">SKIA3009J</p>
61	G/Y	Turn signal (right)	Output	ON	Turn right ON	 <p style="text-align: right; font-size: small;">SKIA3009J</p>
62	R/W	Step lamp LH and RH	Output	OFF	ON (any door open)	0V
					OFF (all doors closed)	Battery voltage
63	L	Interior room/map lamp	Output	OFF	Any door switch ON (open)	0V
					OFF (closed)	Battery voltage
65	V	All door lock actuators (lock)	Output	OFF	OFF (neutral)	0V
					ON (lock)	Battery voltage
66	G/Y	Front door lock actuator RH, rear door lock actuators LH/RH and back door lock actuator (unlock)	Output	OFF	OFF (neutral)	0V
					ON (unlock)	Battery voltage
67	B	Ground	Input	ON	—	0V
68	W/L	Power window power supply (RAP)	Output	—	Ignition switch ON	Battery voltage
					Within 45 seconds after ignition switch OFF	Battery voltage
					More than 45 seconds after ignition switch OFF	0V
					When front door LH or RH is open or power window timer operates	0V
69	W/R	Power window power supply	Output	—	—	Battery voltage
70	W/B	Battery power supply	Input	OFF	—	Battery voltage

1: With Intelligent Key system

2: With remote keyless entry system

BCM (BODY CONTROL MODULE)

< ECU DIAGNOSIS >

Wiring Diagram

INFOID:000000005199725

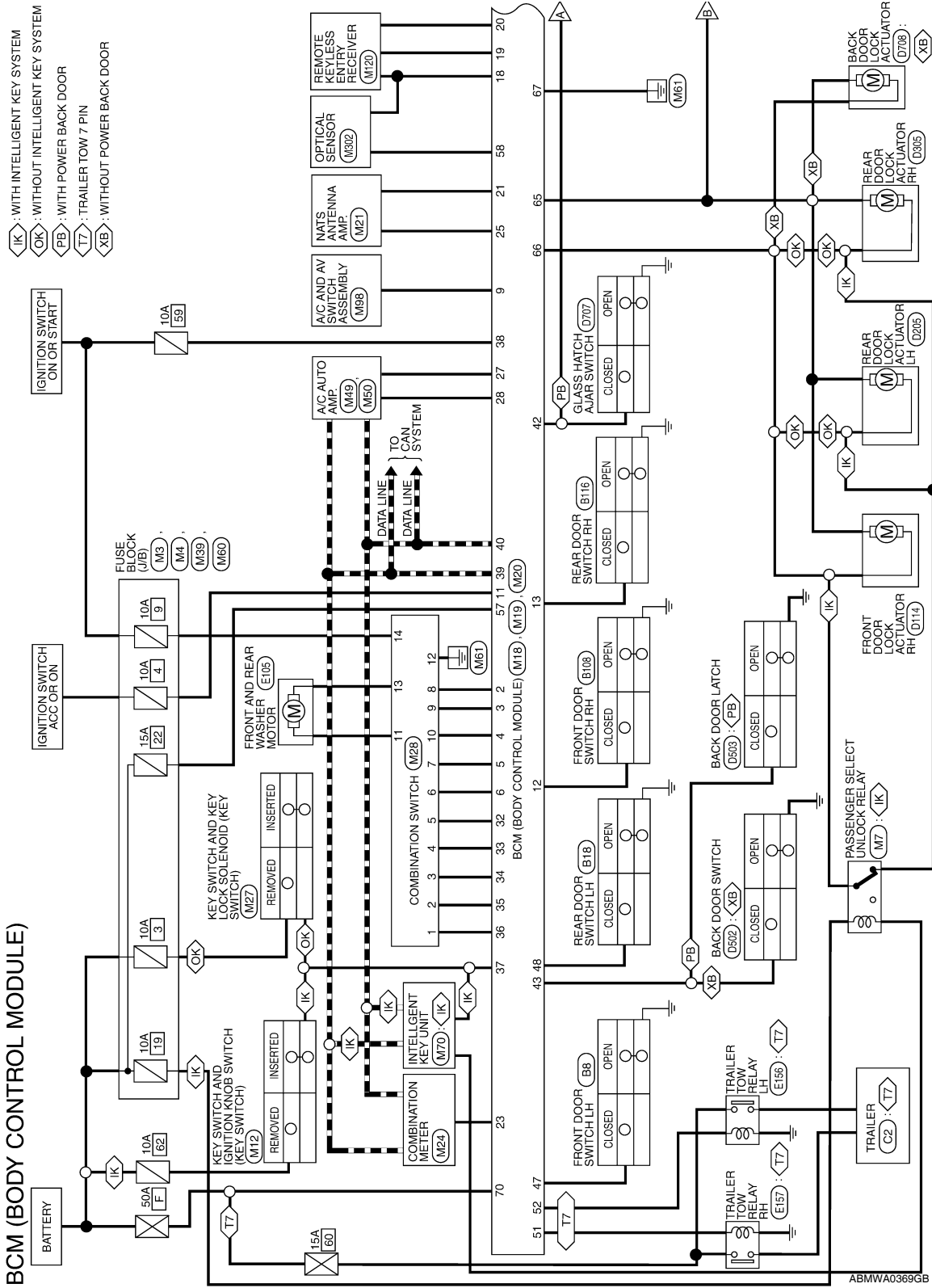

A
B
C
D
E
F
G
H
I
J
K
L
M
N
O
P



BCM (BODY CONTROL MODULE)

< ECU DIAGNOSIS >

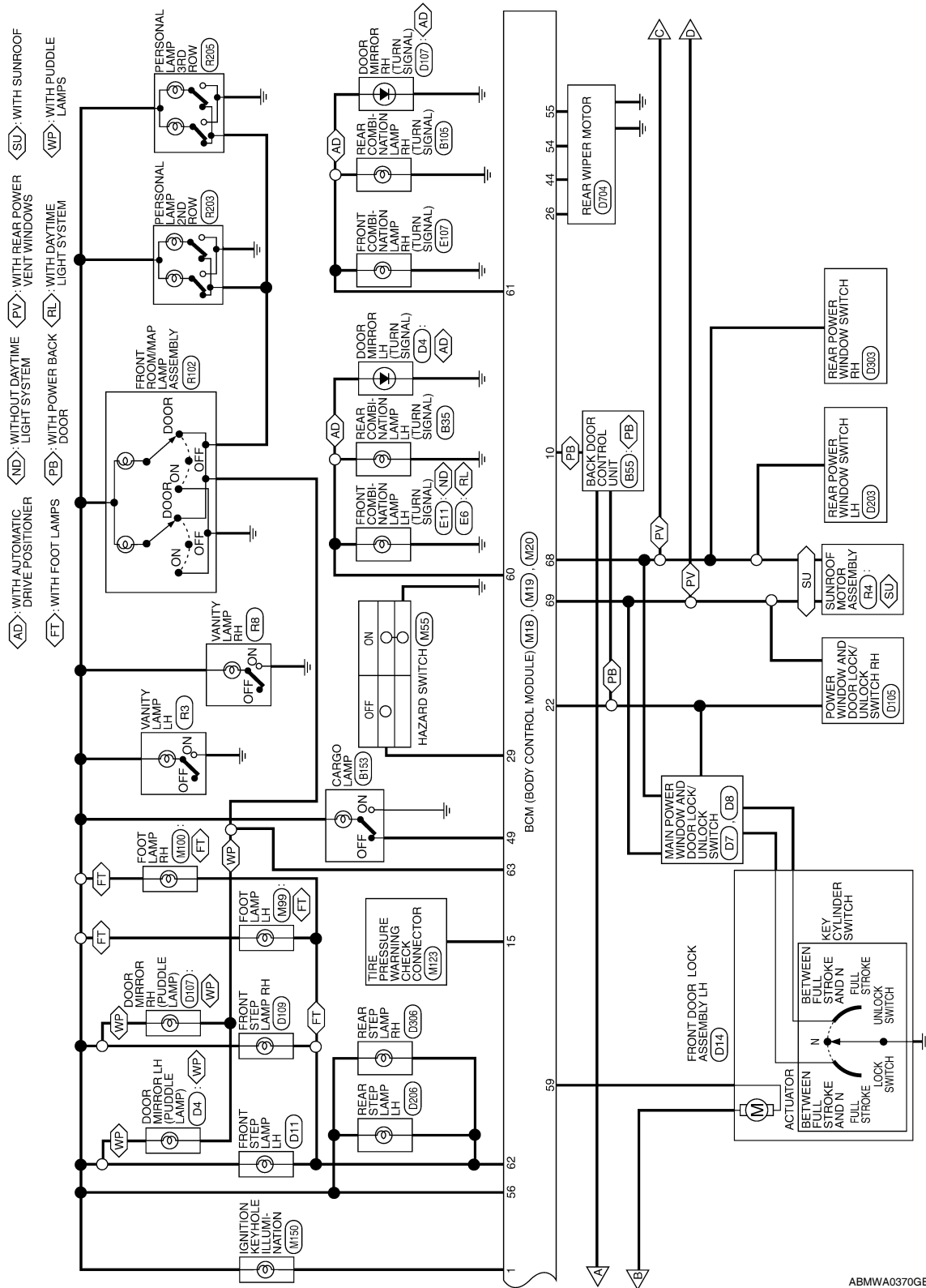

ABMWA0370GB

BCM (BODY CONTROL MODULE)

< ECU DIAGNOSIS >

PV WITH REAR POWER VENT WINDOWS

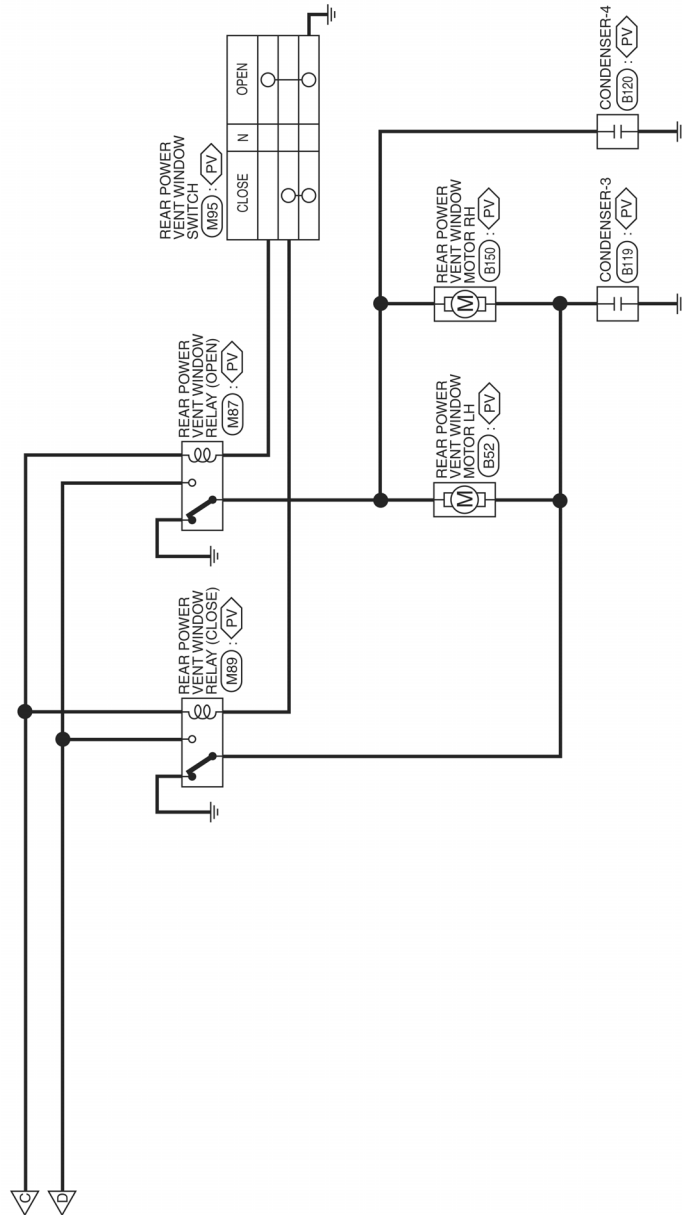

AAMWA0182GB

A
B
C
D
E
F
G
H
I
J
K
L
M
N
O
P

MWI

BCM (BODY CONTROL MODULE)

< ECU DIAGNOSIS >

BCM (BODY CONTROL MODULE) CONNECTORS

Connector No.	M18
Connector Name	BCM (BODY CONTROL MODULE)
Connector Color	WHITE



1	2	3	4	5	6	7	8	9	10	11	12	13	14	15	16	17	18	19	20
21	22	23	24	25	26	27	28	29	30	31	32	33	34	35	36	37	38	39	40

Terminal No.	Color of Wire	Signal Name
1	BR/W	KEY RING OUTPUT
2	SB	INPUT 5
3	G/Y	INPUT 4
4	Y	INPUT 3
5	G/B	INPUT 2
6	V	INPUT 1
7	-	-
8	-	-
9	GR/R	REAR DEFOGGER SW
10	G	IVCS INPUT
11	O	ACC SW
12	R/L	DOOR SW (AS)
13	GR	DOOR SW (RR)
14	-	-
15	L/W	TPMS MODE TRIGGER SW

Terminal No.	Color of Wire	Signal Name
16	-	-
17	-	-
18	P	KEYLESS AND AUTO LIGHT SENSOR GND
19	V/W	KEYLESS TUNER POWER SUPPLY OUTPUT
20	G/W	KEYLESS TUNER SIGNAL
21	G	IMMOBILIZER ANTENNA SIGNAL (CLOCK)
22	W/V	ANTI-PINCH SERIAL LINK (RX, TX)
23	G/O	SECURITY INDICATOR OUTPUT
24	-	-
25	BR	IMMOBILIZER ANTENNA SIGNAL (RX, TX)
26	Y/L	REAR WIPER AUTO STOP SW2
27	W/R	AIRCON SW
28	L/R	BLOWER FAN SW
29	W/B	HAZARD SW
30	-	-
31	-	-
32	R/G	OUTPUT 5
33	R/Y	OUTPUT 4
34	L	OUTPUT 3
35	O/B	OUTPUT 2
36	R/W	OUTPUT 1
37	B/R	KEY SW
38	W/L	IGN SW
39	L	CAN-H
40	P	CAN-L

Connector No.	M19
Connector Name	BCM (BODY CONTROL MODULE)
Connector Color	WHITE



41	42	43	44	45	46	47	48	49	50	51	52	53	54	55
----	----	----	----	----	----	----	----	----	----	----	----	----	----	----

Terminal No.	Color of Wire	Signal Name
41	-	-
42	GR	GLASS HATCH SW
43	R/B	BACK DOOR SW
44	O	REAR WIPER AUTO STOP SW1
45	-	-
46	-	-
47	SB	DOOR SW (DR)
48	R/Y	DOOR SW (RL)
49	R	LUGGAGE LAMP OUTPUT
50	-	-
51	G/Y	TRAILER FLASHER OUTPUT (RIGHT)
52	G/B	TRAILER FLASHER OUTPUT (LEFT)
53	-	-
54	Y	REAR WIPER MOTOR OUTPUT 2
55	SB	REAR WIPER MOTOR OUTPUT 1

BCM (BODY CONTROL MODULE)

< ECU DIAGNOSIS >

A
B
C
D
E
F
G
H
I
J
K
L
M
N
O
P

Connector No.	M28
Connector Name	COMBINATION SWITCH
Connector Color	WHITE

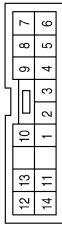

Terminal No.	Color of Wire	Signal Name
1	R/W	INPUT 1
2	O/B	INPUT 2
3	L	INPUT 3
4	R/Y	INPUT 4
5	R/G	INPUT 5
6	V	OUTPUT 1
7	G/B	OUTPUT 2
8	SB	OUTPUT 5
9	G/Y	OUTPUT 4
10	Y	OUTPUT 3
11	V/W	WASHER MOTOR
12	B	GND
13	W/R	WASHER MOTOR
14	R/L	IGN

Connector No.	M20
Connector Name	BCM (BODY CONTROL MODULE)
Connector Color	BLACK



Terminal No.	Color of Wire	Signal Name
56	R/G	BATTERY SAVER OUTPUT
57	Y/R	BAT (FUSE)
58	W/R	AUTO LIGHT SENSOR INPUT 2
59	G	DOOR UNLOCK OUTPUT (DR)
60	G/B	FLASHER OUTPUT (LEFT)
61	G/Y	FLASHER OUTPUT (RIGHT)
62	R/W	STEP LAMP OUTPUT
63	L	ROOM LAMP OUTPUT
64	-	-
65	V	DOOR LOCK OUTPUT (ALL)
66	G/Y	DOOR UNLOCK OUTPUT (OTHER)
67	B	GND (POWER)
68	W/L	POWER WINDOW POWER SUPPLY (LINKED TO RAP)
69	W/R	POWER WINDOW POWER SUPPLY (BAT)
70	W/B	BAT (F/L)

MWI

Fail Safe

ABMIA1056GB

INFOID:000000005199726

Fail-safe index

BCM performs fail-safe control when any DTC listed below is detected.

BCM (BODY CONTROL MODULE)

< ECU DIAGNOSIS >

Display contents of CONSULT	Fail-safe	Cancellation
U1000: CAN COMM CIRCUIT	Inhibit engine cranking	When the BCM re-establishes communication with the other modules.

DTC Inspection Priority Chart

INFOID:000000005199727

If some DTCs are displayed at the same time, perform inspections one by one based on the following priority chart.

Priority	DTC
1	<ul style="list-style-type: none"> U1000: CAN COMM CIRCUIT
2	<ul style="list-style-type: none"> B2190: NATS ANTENNA AMP B2191: DIFFERENCE OF KEY B2192: ID DISCORD BCM-ECM B2193: CHAIN OF BCM-ECM B2013: STRG COMM 1 B2552: INTELLIGENT KEY B2590: NATS MALFUNCTION
3	<ul style="list-style-type: none"> C1729: VHCL SPEED SIG ERR C1735: IGNITION SIGNAL
4	<ul style="list-style-type: none"> C1708: [NO DATA] FL C1709: [NO DATA] FR C1710: [NO DATA] RR C1711: [NO DATA] RL C1712: [CHECKSUM ERR] FL C1713: [CHECKSUM ERR] FR C1714: [CHECKSUM ERR] RR C1715: [CHECKSUM ERR] RL C1716: [PRESSDATA ERR] FL C1717: [PRESSDATA ERR] FR C1718: [PRESSDATA ERR] RR C1719: [PRESSDATA ERR] RL C1720: [CODE ERR] FL C1721: [CODE ERR] FR C1722: [CODE ERR] RR C1723: [CODE ERR] RL C1724: [BATT VOLT LOW] FL C1725: [BATT VOLT LOW] FR C1726: [BATT VOLT LOW] RR C1727: [BATT VOLT LOW] RL

DTC Index

INFOID:000000005199728

NOTE:

- Details of time display
- CRNT: Displays when there is a malfunction now or after returning to the normal condition until turning ignition switch OFF → ON again.
- 1 - 39: Displayed if any previous malfunction is present when current condition is normal. It increases like 1 → 2 → 3...38 → 39 after returning to the normal condition whenever ignition switch OFF → ON. The counter remains at 39 even if the number of cycles exceeds it. It is counted from 1 again when turning ignition switch OFF → ON after returning to the normal condition if the malfunction is detected again.

CONSULT display	Fail-safe	Intelligent Key warning lamp ON	Tire pressure monitor warning lamp ON	Reference page
No DTC is detected. further testing may be required.	—	—	—	—
U1000: CAN COMM CIRCUIT	—	—	—	BCS-33
B2013: STRG COMM 1	—	—	—	SEC-28

BCM (BODY CONTROL MODULE)

< ECU DIAGNOSIS >

CONSULT display	Fail-safe	Intelligent Key warning lamp ON	Tire pressure monitor warning lamp ON	Reference page	A
B2190: NATS ANTENNA AMP	—	—	—	SEC-31 (with I-Key), SEC-134 (without I-Key)	B
B2191: DIFFERENCE OF KEY	—	—	—	SEC-34 (with I-Key), SEC-137 (without I-Key)	C
B2192: ID DISCORD BCM-ECM	—	—	—	SEC-35 (with I-Key), SEC-138 (without I-Key)	D
B2193: CHAIN OF BCM-ECM	—	—	—	SEC-37 (with I-Key), SEC-140 (without I-Key)	E
B2552: INTELLIGENT KEY	—	—	—	SEC-39	
B2590: NATS MALFUNCTION	—	—	—	SEC-40	
C1708: [NO DATA] FL	—	—	—	WT-14	F
C1709: [NO DATA] FR	—	—	—	WT-16	
C1710: [NO DATA] RR	—	—	—	WT-16	G
C1711: [NO DATA] RL	—	—	—	WT-16	
C1712: [CHECKSUM ERR] FL	—	—	—	WT-16	
C1713: [CHECKSUM ERR] FR	—	—	—	WT-16	H
C1714: [CHECKSUM ERR] RR	—	—	—	WT-16	
C1715: [CHECKSUM ERR] RL	—	—	—	WT-16	I
C1716: [PRESSDATA ERR] FL	—	—	—	WT-18	
C1717: [PRESSDATA ERR] FR	—	—	—	WT-16	J
C1718: [PRESSDATA ERR] RR	—	—	—	WT-16	
C1719: [PRESSDATA ERR] RL	—	—	—	WT-16	K
C1720: [CODE ERR] FL	—	—	—	WT-16	
C1721: [CODE ERR] FR	—	—	—	WT-16	L
C1722: [CODE ERR] RR	—	—	—	WT-16	
C1723: [CODE ERR] RL	—	—	—	WT-16	M
C1724: [BATT VOLT LOW] FL	—	—	—	WT-16	
C1725: [BATT VOLT LOW] FR	—	—	—	WT-16	MWI
C1726: [BATT VOLT LOW] RR	—	—	—	WT-16	
C1727: [BATT VOLT LOW] RL	—	—	—	WT-16	
C1729: VHCL SPEED SIG ERR	—	—	—	WT-19	
C1735: IGN_CIRCUIT_OPEN	—	—	—	—	

IPDM E/R (INTELLIGENT POWER DISTRIBUTION MODULE ENGINE ROOM)

< ECU DIAGNOSIS >

IPDM E/R (INTELLIGENT POWER DISTRIBUTION MODULE ENGINE ROOM)

Reference Value

INFOID:000000005199729

VALUES ON THE DIAGNOSIS TOOL

Monitor Item	Condition		Value/Status
MOTOR FAN REQ	Engine idle speed	Changes depending on engine coolant temperature, air conditioner operation status, vehicle speed, etc.	0 - 100 %
A/C COMP REQ	A/C switch OFF		OFF
	A/C switch ON		ON
TAIL&CLR REQ	Lighting switch OFF		OFF
	Lighting switch 1ST, 2ND, HI or AUTO (Light is illuminated)		ON
HL LO REQ	Lighting switch OFF		OFF
	Lighting switch 2ND HI or AUTO (Light is illuminated)		ON
HL HI REQ	Lighting switch OFF		OFF
	Lighting switch HI		ON
FR FOG REQ	Lighting switch 2ND or AUTO (Light is illuminated)	Front fog lamp switch OFF	OFF
		<ul style="list-style-type: none"> • Front fog lamp switch ON • Daytime light activated (Canada only) 	ON
FR WIP REQ	Ignition switch ON	Front wiper switch OFF	STOP
		Front wiper switch INT	1LOW
		Front wiper switch LO	LOW
		Front wiper switch HI	HI
WIP AUTO STOP	Ignition switch ON	Front wiper stop position	STOP P
		Any position other than front wiper stop position	ACT P
WIP PROT	Ignition switch ON	Front wiper operates normally	OFF
		Front wiper stops at fail-safe operation	BLOCK
ST RLY REQ	Ignition switch OFF or ACC		OFF
	Ignition switch START		ON
IGN RLY	Ignition switch OFF or ACC		OFF
	Ignition switch ON		ON
RR DEF REQ	Rear defogger switch OFF		OFF
	Rear defogger switch ON		ON
OIL P SW	Ignition switch OFF, ACC or engine running		OPEN
	Ignition switch ON		CLOSE
DTRL REQ	NOTE: This item is displayed, but cannot be monitored.		OFF
THFT HRN REQ	Not operated		OFF
	<ul style="list-style-type: none"> • Panic alarm is activated • Horn is activated with VEHICLE SECURITY (THEFT WARNING) SYSTEM 		ON

IPDM E/R (INTELLIGENT POWER DISTRIBUTION MODULE ENGINE ROOM)

< ECU DIAGNOSIS >

Monitor Item	Condition	Value/Status
HORN CHIRP	Not operated	OFF
	Door locking with keyfob or Intelligent Key (if equipped) (horn chirp mode)	ON

Terminal Layout

INFOID:000000005199730

TERMINAL LAYOUT — TYPE A

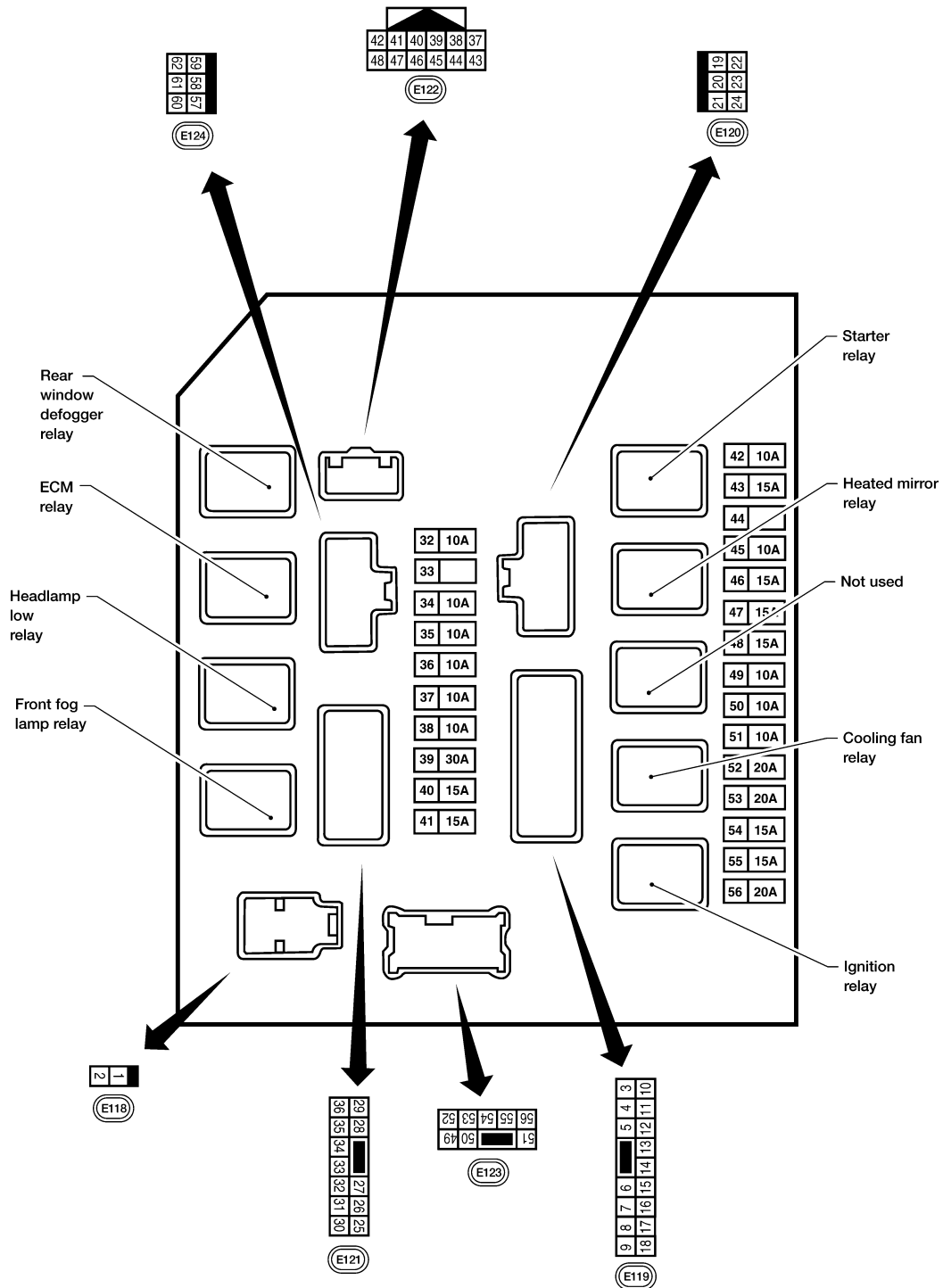

A
B
C
D
E
F
G
H
I
J
K
L
M
N
O
P

MWI

IPDM E/R (INTELLIGENT POWER DISTRIBUTION MODULE ENGINE ROOM)

< ECU DIAGNOSIS >

TERMINAL LAYOUT — TYPE B

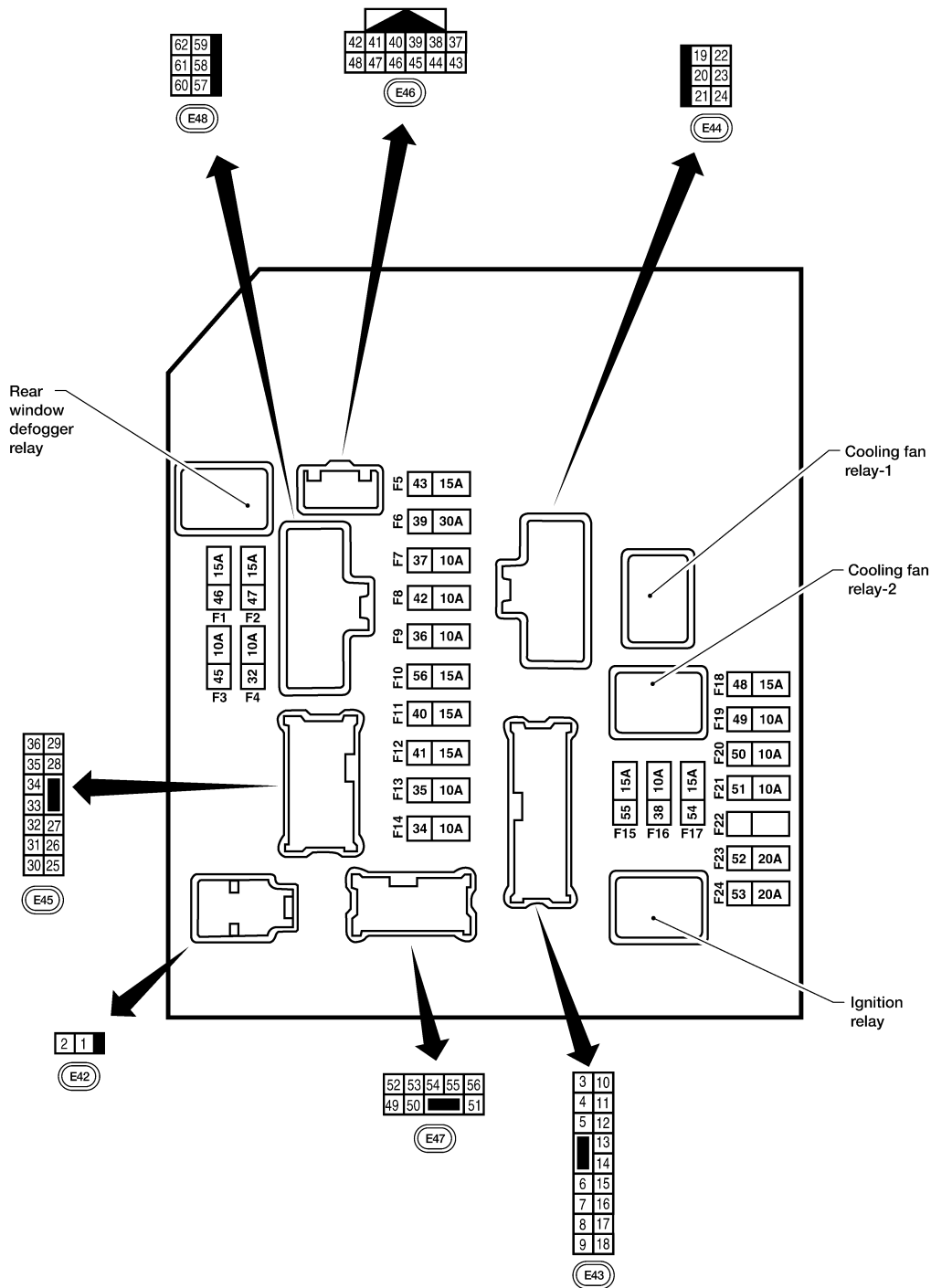

NOTE:

Numbers preceded by an "F" represent the fuse numbers imprinted on the IPDM E/R. The other numbers represent the fuse numbers as they appear in the wiring diagrams.

Physical Values

PHYSICAL VALUES

AAMIA0364GB

INFOID:000000005199731

IPDM E/R (INTELLIGENT POWER DISTRIBUTION MODULE ENGINE ROOM)

< ECU DIAGNOSIS >

Terminal	Wire color	Signal name	Signal input/output	Measuring condition		Reference value (Approx.)
				Ignition switch	Operation or condition	
1	B/Y	Battery power supply	Input	OFF	—	Battery voltage
2	R	Battery power supply	Input	OFF	—	Battery voltage
3	BR	ECM relay	Output	—	Ignition switch ON or START	Battery voltage
					Ignition switch OFF or ACC	0V
4	W/L	ECM relay	Output	—	Ignition switch ON or START	Battery voltage
					Ignition switch OFF or ACC	0V
6	L	Throttle control motor relay	Output	—	Ignition switch ON or START	Battery voltage
					Ignition switch OFF or ACC	0V
7	W/B	ECM relay control	Input	—	Ignition switch ON or START	0V
					Ignition switch OFF or ACC	Battery voltage
8	R/B	Fuse 54	Output	—	Ignition switch ON or START	Battery voltage
					Ignition switch OFF or ACC	0V
10	G	Fuse 45 (Canada only)	Output	ON	Daytime light system active	0V
					Daytime light system inactive	Battery voltage
11	Y/B	A/C compressor	Output	ON or START	A/C switch ON or defrost A/C switch	Battery voltage
					A/C switch OFF or defrost A/C switch	0V
12	L/W	Ignition switch supplied power	Input	—	OFF or ACC	0V
					ON or START	Battery voltage
13	B/Y	Fuel pump relay	Output	—	Ignition switch ON or START	Battery voltage
					Ignition switch OFF or ACC	0V
14	Y/R	Fuse 49	Output	—	Ignition switch ON or START	Battery voltage
					Ignition switch OFF or ACC	0V
15	LG/B	Fuse 50	Output	—	Ignition switch ON or START	Battery voltage
					Ignition switch OFF or ACC	0V
16	G	Fuse 51	Output	—	Ignition switch ON or START	Battery voltage
					Ignition switch OFF or ACC	0V
17	W	Fuse 55	Output	—	Ignition switch ON or START	Battery voltage
					Ignition switch OFF or ACC	0V
19	W/R	Starter motor	Output	START	—	Battery voltage
21	BR	Ignition switch supplied power	Input	—	OFF or ACC	0V
					START	Battery voltage
22	G	Battery power supply	Output	OFF	—	Battery voltage
23	GR/W	Door mirror defogger output signal	Output	—	When rear defogger switch is ON	Battery voltage
					When raker defogger switch is OFF	0V
24	L	Cooling fan relay	Output	—	Conditions correct for cooling fan operation	Battery voltage
					Conditions not correct for cooling fan operation	0V

A

B

C

D

E

F

G

H

I

J

K

L

M

MWI

O

P

IPDM E/R (INTELLIGENT POWER DISTRIBUTION MODULE ENGINE ROOM)

< ECU DIAGNOSIS >

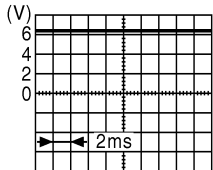
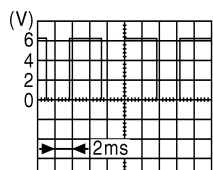
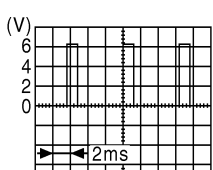
Terminal	Wire color	Signal name	Signal input/output	Measuring condition		Reference value (Approx.)
				Ignition switch	Operation or condition	
27	W/B	Fuse 38 (With trailer tow)	Output	—	Ignition switch ON or START	Battery voltage
					Ignition switch OFF or ACC	0V
30	W	Fuse 53	Output	—	Ignition switch ON or START	Battery voltage
					Ignition switch OFF or ACC	0V
32	L	Wiper low speed signal	Output	ON or START	Wiper switch OFF	Battery voltage
					LO or INT	0V
35	L/B	Wiper high speed signal	Output	ON or START	Wiper switch OFF, LO, INT	Battery voltage
					HI	0V
37	Y	Power generation command signal	Output	—	Ignition switch ON	 <p style="text-align: right;">JPMIA0001GB 6.3 V</p>
					40% is set on "Active test," "ALTERNATOR DUTY" of "ENGINE"	 <p style="text-align: right;">JPMIA0002GB 3.8 V</p>
					40% is set on "Active test," "ALTERNATOR DUTY" of "ENGINE"	 <p style="text-align: right;">JPMIA0003GB 1.4 V</p>
38	B	Ground	Input	—	—	0V
39	L	CAN-H	—	ON	—	—
40	P	CAN-L	—	ON	—	—
42	GR	Oil pressure switch	Input	—	Engine running	Battery voltage
					Engine stopped	0V
43	L/Y	Wiper auto stop signal	Input	ON or START	Wiper switch OFF, LO, INT	Battery voltage
44	BR	Daytime light relay control (Canada only)	Input	ON	Daytime light system active	0V
					Daytime light system inactive	Battery voltage
45	G/W	Horn relay control	Input	ON	When door locks are operated using keyfob or Intelligent Key (if equipped) (OFF → ON)*	Battery voltage → 0V

IPDM E/R (INTELLIGENT POWER DISTRIBUTION MODULE ENGINE ROOM)

< ECU DIAGNOSIS >

Terminal	Wire color	Signal name	Signal input/output	Measuring condition		Reference value (Approx.)	
				Ignition switch	Operation or condition		
46	GR	Fuel pump relay control	Input	—	Ignition switch ON or START	0V	
					Ignition switch OFF or ACC	Battery voltage	
47	O	Throttle control motor relay control	Input	—	Ignition switch ON or START	0V	
					Ignition switch OFF or ACC	Battery voltage	
48	B/R	Starter relay (inhibit switch)	Input	ON or START	Selector lever in "P" or "N"	0V	
					Selector lever any other position	Battery voltage	
49	R/L	Trailer tow relay (With trailer tow) Illumination (Without trailer tow)	Output	ON	Lighting switch must be in the 1st position	OFF	0V
					ON	Battery voltage	
50	W/R	Front fog lamp (LH)	Output	ON or START	Lighting switch must be in the 2nd position (LOW beam is ON) and the front fog lamp switch	OFF	0V
					ON	Battery voltage	
51	W/R	Front fog lamp (RH)	Output	ON or START	Lighting switch must be in the 2nd position (LOW beam is ON) and the front fog lamp switch	OFF	0V
					ON	Battery voltage	
52	L	LH low beam head-lamp	Output	—	Lighting switch in 2nd position	Battery voltage	
54	R/Y	RH low beam head-lamp	Output	—	Lighting switch in 2nd position	Battery voltage	
55	G	LH high beam head-lamp	Output	—	Lighting switch in 2nd position and placed in HIGH or PASS position	Battery voltage	
56	Y (With DTRL)	RH high beam head-lamp	Output	—	Lighting switch in 2nd position and placed in HIGH or PASS position	Battery voltage	
56	L/W (Without DTRL)	RH high beam head-lamp	Output	—	Lighting switch in 2nd position and placed in HIGH or PASS position	Battery voltage	
57	R/L	Parking, license, and tail lamp	Output	ON	Lighting switch 1st position	OFF	0V
					ON	Battery voltage	
59	B	Ground	Input	—	—	0V	
60	B/W	Rear window defogger relay	Output	ON or START	Rear defogger switch ON	Battery voltage	
					Rear defogger switch OFF	0V	
61	BR	Fuse 32 (With trailer tow)	Output	OFF	—	Battery voltage	

*: When horn reminder is ON

IPDM E/R (INTELLIGENT POWER DISTRIBUTION MODULE ENGINE ROOM)

< ECU DIAGNOSIS >

Wiring Diagram

INFOID:000000005199732

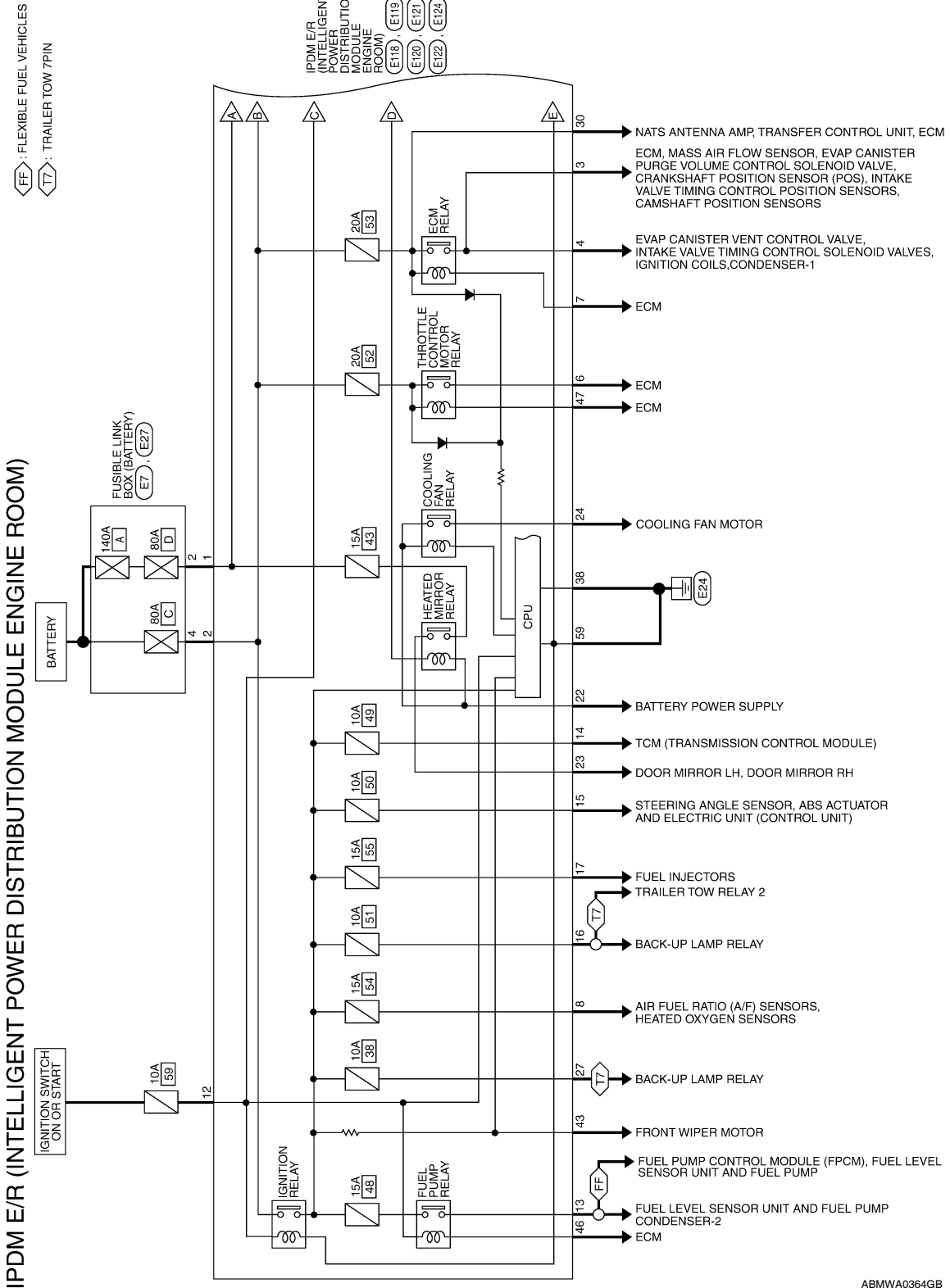

ABMWA0364GB

IPDM E/R (INTELLIGENT POWER DISTRIBUTION MODULE ENGINE ROOM)

< ECU DIAGNOSIS >

FL: WITH FRONT FOG LAMP
N: FOR CANADA
T7: TRAILER TOW 7PIN

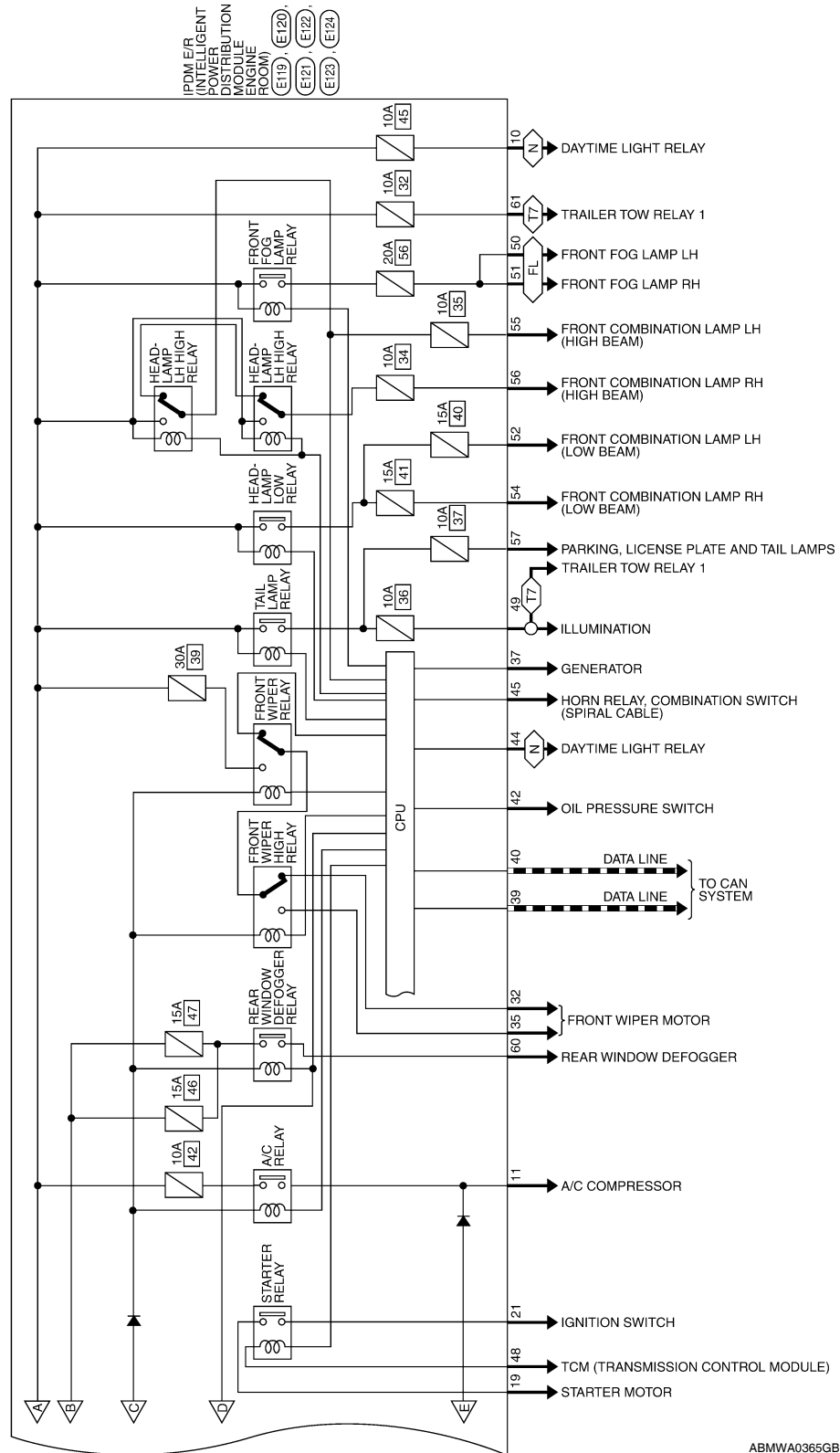

ABMWA0365GB

A
B
C
D
E
F
G
H
I
J
K
L
M
N
O
P

MWI

IPDM E/R (INTELLIGENT POWER DISTRIBUTION MODULE ENGINE ROOM)

< ECU DIAGNOSIS >

IPDM E/R (INTELLIGENT POWER DISTRIBUTION MODULE ENGINE ROOM) CONNECTORS

Connector No.	E7
Connector Name	FUSIBLE LINK BOX (BATTERY)
Connector Color	GRAY



Terminal No.	Color of Wire	Signal Name
4	R	-

Connector No.	E27
Connector Name	FUSIBLE LINK BOX (BATTERY)
Connector Color	BROWN



Terminal No.	Color of Wire	Signal Name
2	B/Y	-

Connector No.	E118
Connector Name	IPDM E/R (INTELLIGENT POWER DISTRIBUTION MODULE ENGINE ROOM)
Connector Color	BLACK



Terminal No.	Color of Wire	Signal Name
1	B/Y	F/L USM
2	R	F/L MAIN

Connector No.	E119
Connector Name	IPDM E/R (INTELLIGENT POWER DISTRIBUTION MODULE ENGINE ROOM)
Connector Color	WHITE

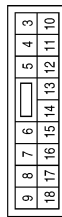

Terminal No.	Color of Wire	Signal Name
3	BR	IGN COIL
4	W/L	ECM
5	-	-
6	L	ETC
7	W/B	ECM RLY CONT
8	R/B	O2 SENSOR
9	-	-
10	G	DTRL RLY SUPPLY
11	Y/B	A/C COMPRESSOR
12	L/W	IGN SW (IG)
13	B/Y	FUEL PUMP
14	Y/R	AT CU IGN SUPPLY
15	LG/B	ABS IGN SUPPLY
16	G	REVERSE LAMP
17	W	INJECTOR
18	-	-

Connector No.	E120
Connector Name	IPDM E/R (INTELLIGENT POWER DISTRIBUTION MODULE ENGINE ROOM)
Connector Color	WHITE

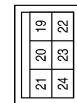

Terminal No.	Color of Wire	Signal Name
19	W/R	STARTER MTR
20	-	-
21	BR	IGN SW (ST)
22	G	F/L MOTOR FAN
23	GR/W	HEATED MIRROR
24	L	MOTOR FAN 2

Connector No.	E121
Connector Name	IPDM E/R (INTELLIGENT POWER DISTRIBUTION MODULE ENGINE ROOM)
Connector Color	BROWN

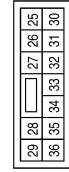

Terminal No.	Color of Wire	Signal Name
25	-	-
26	-	-
27	W/B	TTOW REV LAMP
28	-	-
29	-	-
30	W	ECM BAT
31	-	-
32	L	FR WIPER LO
33	-	-
34	-	-
35	L/B	FR WIPER HI
36	-	-

ABMIA1044GB

IPDM E/R (INTELLIGENT POWER DISTRIBUTION MODULE ENGINE ROOM)

< ECU DIAGNOSIS >

Connector No.	E123
Connector Name	IPDM E/R (INTELLIGENT POWER DISTRIBUTION MODULE ENGINE ROOM)
Connector Color	BROWN

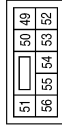

Terminal No.	Color of Wire	Signal Name
49	R/L	ILLUMINATION
50	W/R	FR FOG LAMP LH
51	W/R	FR FOG LAMP RH
52	L	H/LAMP LO LH
53	-	-
54	R/Y	H/LAMP LO RH
55	G	H/LAMP HI LH
56	L/W	H/LAMP HI RH (WITHOUT DAYTIME LIGHT)
56	Y	H/LAMP HI RH (WITH DAYTIME LIGHT)

Terminal No.	Color of Wire	Signal Name
37	Y	ALT-C CONT
38	B	GND (SIGNAL)
39	L	CAN-H
40	P	CAN-L
41	-	-
42	GR	OIL PRESSURE SW
43	L/Y	AUTO STOP SW
44	BR	DTRL RLY CONT
45	G/W	ANT THEFT HORN
46	GR	FUEL PUMP RLY CONT
47	O	ETC RLY CONT
48	B/R	INHIBIT SW

Connector No.	E122
Connector Name	IPDM E/R (INTELLIGENT POWER DISTRIBUTION MODULE ENGINE ROOM)
Connector Color	WHITE

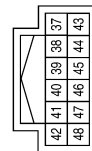

Terminal No.	Color of Wire	Signal Name
61	BR	TRAIL RLY SUPPLY
62	-	-

Connector No.	E124
Connector Name	IPDM E/R (INTELLIGENT POWER DISTRIBUTION MODULE ENGINE ROOM)
Connector Color	BLACK



Terminal No.	Color of Wire	Signal Name
57	R/L	TAIL LAMP
58	-	-
59	B	GND (POWER)
60	B/W	RR DEF

ABMIA1045GB

INFOID:000000005199733

Fail Safe

CAN COMMUNICATION CONTROL

When CAN communication with ECM and BCM is impossible, IPDM E/R performs fail-safe control. After CAN communication recovers normally, it also returns to normal control.

If No CAN Communication Is Available With ECM

A
B
C
D
E
F
G
H
I
J
K
L
M
N
O
P



IPDM E/R (INTELLIGENT POWER DISTRIBUTION MODULE ENGINE ROOM)

< ECU DIAGNOSIS >

Control part	Fail-safe in operation
Cooling fan	<ul style="list-style-type: none"> • Turns ON the cooling fan relay when the ignition switch is turned ON • Turns OFF the cooling fan relay when the ignition switch is turned OFF

If No CAN Communication Is Available With BCM

Control part	Fail-safe in operation
Headlamp	<ul style="list-style-type: none"> • Turns ON the headlamp low relay when the ignition switch is turned ON • Turns OFF the headlamp low relay when the ignition switch is turned OFF • Headlamp high LH/RH relays OFF
<ul style="list-style-type: none"> • Parking lamps • License plate lamps • Tail lamps 	<ul style="list-style-type: none"> • Turns ON the tail lamp relay when the ignition switch is turned ON • Turns OFF the tail lamp relay when the ignition switch is turned OFF
Front wiper	<ul style="list-style-type: none"> • The status just before activation of fail-safe control is maintained until the ignition switch is turned OFF while the front wiper is operating at LO or HI speed. • The wiper is operated at LO speed until the ignition switch is turned OFF if the fail-safe control is activated while the front wiper is set in the INT mode and the front wiper motor is operating.
Rear window defogger	Rear window defogger relay OFF
A/C compressor	A/C relay OFF
Front fog lamps	Front fog lamp relay OFF

IGNITION RELAY MALFUNCTION DETECTION FUNCTION

- IPDM E/R monitors the voltage at the contact circuit and excitation coil circuit of the ignition relay inside it.
- IPDM E/R judges the ignition relay error if the voltage differs between the contact circuit and the excitation coil circuit.
- If the ignition relay cannot turn OFF due to contact seizure, it activates the tail lamp relay for 10 minutes to alert the user to the ignition relay malfunction when the ignition switch is turned OFF.

Ignition switch	Ignition relay	Tail lamp relay
ON	ON	—
OFF	OFF	—

NOTE:

The tail lamp turns OFF when the ignition switch is turned ON.

FRONT WIPER CONTROL

IPDM E/R detects front wiper stop position by a front wiper auto stop signal.

When a front wiper auto stop signal is in the conditions listed below, IPDM E/R stops power supply to wiper after repeating a front wiper 10 second activation and 20 second stop five times.

Ignition switch	Front wiper switch	Auto stop signal
ON	OFF	Front wiper stop position signal cannot be input 10 seconds.
	ON	The signal does not change for 10 seconds.

NOTE:

This operation status can be confirmed on the IPDM E/R “DATA MONITOR” that displays “Block” for the item “WIP PROT” while the wiper is stopped.

STARTER MOTOR PROTECTION FUNCTION

IPDM E/R turns OFF the starter control relay to protect the starter motor when the starter control relay remains active for 90 seconds.

IPDM E/R (INTELLIGENT POWER DISTRIBUTION MODULE ENGINE ROOM)

< ECU DIAGNOSIS >

DTC Index

INFOID:000000005199734

CONSULT-III display	Fail-safe	TIME ^{NOTE}		Refer to
No DTC is detected. further testing may be required.	—	—	—	—
U1000: CAN COMM CIRCUIT	×	CRNT	1 – 39	PCS-16

NOTE:

The details of TIME display are as follows.

- CRNT: The malfunctions that are detected now
- 1 - 39: The number is indicated when it is normal at present and a malfunction was detected in the past. It increases like 0 → 1 → 2 ... 38 → 39 after returning to the normal condition whenever IGN OFF → ON. It is fixed to 39 until the self-diagnosis results are erased if it is over 39. It returns to 0 when a malfunction is detected again in the process.

A
B
C
D
E
F
G
H
I
J
K
L
M
N
O
P

MWI

THE FUEL GAUGE POINTER DOES NOT MOVE

< SYMPTOM DIAGNOSIS >

SYMPTOM DIAGNOSIS

THE FUEL GAUGE POINTER DOES NOT MOVE

Description

INFOID:000000004918096

Fuel gauge needle will not move from a certain position.

Diagnosis Procedure

INFOID:000000004918097

1. CHECK COMBINATION METER INPUT SIGNAL

1. Select "METER/M&A" on CONSULT-III.
2. Using "FUEL METER" of "DATA MONITOR", compare the monitor value with the fuel gauge reading on the combination meter. Refer to [MWI-36. "Component Function Check"](#).

Does monitor value match fuel gauge reading?

YES >> GO TO 2

NO >> Replace combination meter. Refer to [MWI-106. "Removal and Installation"](#).

2. CHECK FUEL LEVEL SENSOR SIGNAL CIRCUIT

Check the fuel level sensor signal circuit. Refer to [MWI-36. "Diagnosis Procedure"](#).

Is the inspection result normal?

YES >> GO TO 3

NO >> Repair harness or connector.

3. CHECK FUEL LEVEL SENSOR UNIT

Perform a unit check for the fuel level sensor unit. Refer to [MWI-37. "Component Inspection"](#).

Is the inspection result normal?

YES >> GO TO 4

NO >> Replace fuel level sensor unit. Refer to [FL-12. "Removal and Installation"](#).

4. CHECK FLOAT INTERFERENCE

Check that the float arm does not interfere or bind with any of the components in the fuel tank.

Is the inspection result normal?

YES >> Replace combination meter. Refer to [MWI-106. "Removal and Installation"](#).

NO >> Repair or replace malfunctioning parts.

THE FUEL GAUGE POINTER DOES NOT MOVE TO "F" WHEN REFUELING

< SYMPTOM DIAGNOSIS >

THE FUEL GAUGE POINTER DOES NOT MOVE TO "F" WHEN REFUELING

Description

INFOID:000000004918098

The fuel gauge needle will not move to "F" position when refueling.

Diagnosis Procedure

INFOID:000000004918099

1.OBSERVE FUEL GAUGE

Does it take a long time for the pointer to move to FULL position?

YES or NO

YES >> GO TO 2

NO >> GO TO 3

2.IDENTIFY FUELING CONDITION

Was the vehicle fueled with the ignition switch ON?

YES or NO

YES >> Be sure to fuel the vehicle with the ignition switch OFF. Otherwise, it will take a long time to move to FULL position because of the characteristic of the fuel gauge.

NO >> GO TO 3

3.OBSERVE VEHICLE POSITION

Is the vehicle parked on an incline?

YES or NO

YES >> Check the fuel level indication with vehicle on a level surface.

NO >> GO TO 4

4.OBSERVE FUEL GAUGE POINTER

During driving, does the fuel gauge pointer move gradually toward EMPTY position?

YES or NO

YES >> Check the components. Refer to [MWI-37. "Component Inspection"](#).

NO >> The float arm may interfere or bind with any of the components in the fuel tank.

A
B
C
D
E
F
G
H
I
J
K
L
M
O
P

MWI

THE OIL PRESSURE WARNING LAMP DOES NOT TURN ON

< SYMPTOM DIAGNOSIS >

THE OIL PRESSURE WARNING LAMP DOES NOT TURN ON

Description

INFOID:000000004918100

The oil pressure warning lamp stays off when the ignition switch is turned ON.

Diagnosis Procedure

INFOID:000000004918101

1.CHECK OIL PRESSURE WARNING LAMP

Perform IPDM E/R auto active test. Refer to [PCS-12, "Diagnosis Description"](#).

Is oil pressure warning lamp illuminated?

YES >> GO TO 2

NO >> Replace combination meter. Refer to [MWI-106, "Removal and Installation"](#).

2.CHECK OIL PRESSURE SWITCH SIGNAL CIRCUIT

Check the oil pressure switch signal circuit. Refer to [MWI-38, "Diagnosis Procedure"](#).

Is the inspection result normal?

YES >> GO TO 3

NO >> Repair harness or connector.

3.CHECK OIL PRESSURE SWITCH UNIT

Perform a unit check for the oil pressure switch. Refer to [MWI-38, "Component Inspection"](#).

Is the inspection result normal?

YES >> Replace IPDM E/R. Refer to [PCS-32, "Removal and Installation of IPDM E/R"](#).

NO >> Replace oil pressure switch.

THE OIL PRESSURE WARNING LAMP DOES NOT TURN OFF

< SYMPTOM DIAGNOSIS >

THE OIL PRESSURE WARNING LAMP DOES NOT TURN OFF

Description

INFOID:000000004918102

The oil pressure warning lamp remains illuminated while the engine is running (normal oil pressure).

Diagnosis Procedure

INFOID:000000004918103

Regarding Wiring Diagram information, refer to [MWI-45, "Wiring Diagram"](#).

1. CHECK OIL PRESSURE WARNING LAMP

Perform IPDM E/R auto active test. Refer to [PCS-12, "Diagnosis Description"](#).

Is oil pressure warning lamp illuminated?

YES >> GO TO 2

NO >> Replace combination meter. Refer to [MWI-106, "Removal and Installation"](#).

2. CHECK IPDM E/R OUTPUT VOLTAGE

1. Turn ignition switch OFF.
2. Disconnect the oil pressure switch connector.
3. Turn ignition switch ON.
4. Check voltage between the oil pressure switch harness connector F4 terminal 1 and ground.

1 – Ground : Approx. 12V

Is the inspection result normal?

YES >> GO TO 3

NO >> GO TO 4

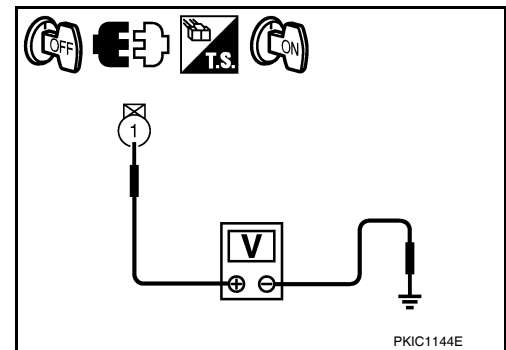

3. CHECK OIL PRESSURE SWITCH

Perform a unit check for the oil pressure switch. Refer to [MWI-38, "Component Inspection"](#).

Is the inspection result normal?

YES >> Replace IPDM E/R. Refer to [PCS-32, "Removal and Installation of IPDM E/R"](#).

NO >> Replace oil pressure switch.

4. CHECK OIL PRESSURE SWITCH SIGNAL CIRCUIT

Check the oil pressure switch signal circuit. Refer to [MWI-38, "Diagnosis Procedure"](#).

Is the inspection result normal?

YES >> Replace IPDM E/R. Refer to [PCS-32, "Removal and Installation of IPDM E/R"](#).

NO >> Repair harness or connector.

A
B
C
D
E
F
G
H
I
J
K
L
M
O
P

MWI

THE PARKING BRAKE RELEASE WARNING CONTINUES DISPLAYING, OR DOES NOT DISPLAY

< SYMPTOM DIAGNOSIS >

THE PARKING BRAKE RELEASE WARNING CONTINUES DISPLAYING, OR DOES NOT DISPLAY

Description

INFOID:000000004918104

- The parking brake warning is displayed while driving the vehicle even though the parking brake is released.
- The parking brake warning is not displayed even though driving the vehicle with the parking brake applied.

Diagnosis Procedure

INFOID:000000004918105

1. CHECK PARKING BRAKE WARNING LAMP OPERATION

1. Start engine.
2. Monitor "BRAKE" warning lamp while applying and releasing the parking brake.

BRAKE warning lamp

Parking brake applied : ON

Parking brake released : OFF

Is the inspection result normal?

- YES >> Replace combination meter. Refer to [MWI-106, "Removal and Installation"](#).
NO >> GO TO 2

2. CHECK PARKING BRAKE SWITCH SIGNAL CIRCUIT

1. Turn ignition switch OFF.
2. Check the parking brake switch signal circuit. Refer to [MWI-39, "Diagnosis Procedure"](#).

Is the inspection result normal?

- YES >> GO TO 3
NG >> Repair harness or connector.

3. CHECK PARKING BRAKE SWITCH UNIT

Perform a unit check for the parking brake switch. Refer to [MWI-39, "Component Inspection"](#).

Is the inspection result normal?

- YES >> Replace combination meter. Refer to [MWI-106, "Removal and Installation"](#).
NO >> Replace parking brake switch.

THE LOW WASHER FLUID WARNING CONTINUES DISPLAYING, OR DOES NOT DISPLAY

< SYMPTOM DIAGNOSIS >

THE LOW WASHER FLUID WARNING CONTINUES DISPLAYING, OR DOES NOT DISPLAY

Description

INFOID:000000004918106

- The warning is still displayed even after washer fluid is added.
- The warning is not displayed even though the washer tank is empty.

Diagnosis Procedure

INFOID:000000004918107

1. CHECK WASHER FLUID LEVEL SWITCH SIGNAL CIRCUIT

Check the washer fluid level switch signal circuit. Refer to [MWI-40. "Diagnosis Procedure"](#).

Is the inspection result normal?

- YES >> GO TO 2
- NO >> Repair harness or connector.

2. CHECK WASHER FLUID LEVEL SWITCH UNIT

Perform a unit check for the washer fluid level switch. Refer to [MWI-40. "Component Inspection"](#).

Is the inspection result normal?

- YES >> Replace combination meter. Refer to [MWI-106. "Removal and Installation"](#).
- NO >> Replace washer level switch.

A
B
C
D
E
F
G
H
I
J
K
L
M
O
P

MWI

THE DOOR OPEN WARNING CONTINUES DISPLAYING, OR DOES NOT DISPLAY

< SYMPTOM DIAGNOSIS >

THE DOOR OPEN WARNING CONTINUES DISPLAYING, OR DOES NOT DISPLAY

Description

INFOID:000000004918108

- The door open warning is displayed even though all of the doors are closed.
- The door open warning is not displayed even though a door is open.

Diagnosis Procedure

INFOID:000000004918109

1. CHECK COMBINATION METER INPUT SIGNAL

1. Select "METER/M&A" on CONSULT-III.
2. Monitor "DOOR W/L" of "DATA MONITOR" while opening and closing doors.

DOOR W/L

Front door LH open	: ON
Front door LH closed	: OFF
Front door RH open	: ON
Front door RH closed	: OFF
Rear door LH open	: ON
Rear door LH closed	: OFF
Rear door RH open	: ON
Rear door RH closed	: OFF

Is the inspection result normal?

- YES >> Replace combination meter. Refer to [MWI-106. "Removal and Installation"](#).
NO >> GO TO 2

2. CHECK BCM INPUT SIGNAL

1. Select "BCM" on CONSULT-III.
2. Monitor "DOOR SW DR", "DOOR SW AS", "DOOR SW RL" and "DOOR SW RR" of "DATA MONITOR" while opening and closing doors.

When doors are open

DOOR SW DR	: ON
DOOR SW AS	: ON
DOOR SW RL	: ON
DOOR SW RR	: ON

When doors are closed

DOOR SW DR	: OFF
DOOR SW AS	: OFF
DOOR SW RL	: OFF
DOOR SW RR	: OFF

Is the inspection result normal?

- YES >> Replace BCM. Refer to [BCS-60. "Removal and Installation"](#).
NO >> GO TO 3

3. CHECK DOOR SWITCHES

THE DOOR OPEN WARNING CONTINUES DISPLAYING, OR DOES NOT DISPLAY

< SYMPTOM DIAGNOSIS >

1. Disconnect door switches.
2. Check continuity between door switch (front LH), (front RH), (rear LH) and (rear RH) terminal 2 and exposed metal of switch while pressing and releasing switch.

When door switch is released : Continuity should exist

When door switch is pushed : Continuity should not exist

Is the inspection result normal?

- YES >> Repair open or short in circuit between BCM and door switch.
- NO >> Replace door switch.

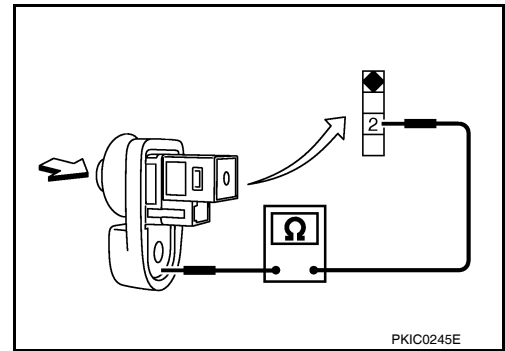

A
B
C
D
E
F
G
H
I
J
K
L
M
O
P

MWI

THE LIFTGATE OPEN WARNING CONTINUES DISPLAYING, OR DOES NOT DISPLAY

< SYMPTOM DIAGNOSIS >

THE LIFTGATE OPEN WARNING CONTINUES DISPLAYING, OR DOES NOT DISPLAY

Description

INFOID:000000004918110

- The liftgate open warning is displayed continuously even though the back door is closed.
- The liftgate open warning is not displayed even though the back door is open.

Diagnosis Procedure

INFOID:000000004918111

Regarding Wiring Diagram information, refer to [MWI-45, "Wiring Diagram"](#).

1. CHECK BCM INPUT SIGNAL

1. Select "BCM" on CONSULT-III.
2. Monitor "BACK DOOR SW" of "DATA MONITOR" while opening and closing the back door.

When back door is open

BACK DOOR SW : ON

When back door is closed

BACK DOOR SW : OFF

Is the inspection result normal?

YES >> GO TO 2

NO >> GO TO 4

2. CHECK SELF-DIAGNOSIS OF BCM

Select "BCM" on CONSULT-III and perform "SELF-DIAGNOSIS".

Is the inspection result normal?

YES >> GO TO 3

NO >> Refer to [BCS-55, "DTC Index"](#).

3. CHECK SELF-DIAGNOSIS OF COMBINATION METER

Select "METER/M&A" on CONSULT-III and perform "SELF-DIAGNOSIS".

Is the inspection result normal?

YES >> Replace combination meter. Refer to [MWI-106, "Removal and Installation"](#).

NO >> Refer to [MWI-62, "DTC Index"](#).

4. CHECK BACK DOOR SWITCH CIRCUIT

With Power Back Door

1. Turn ignition switch OFF.
2. Disconnect BCM connector M19 and back door latch connector D503.
3. Check continuity between BCM harness connector M19 (A) terminal 43 and back door latch harness connector D503 (B) terminal 7.

43 - 7 : Continuity should exist.

4. Check continuity between BCM harness connector M19 (A) terminal 43 and ground.

43 - Ground : Continuity should not exist.

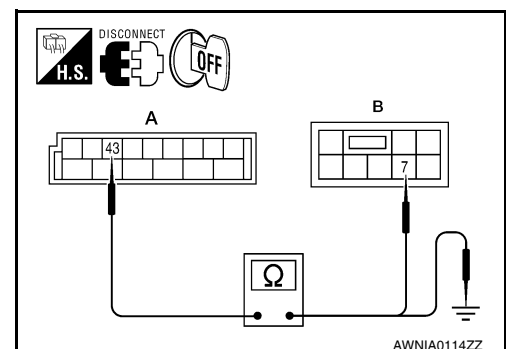

Without Power Back Door

THE LIFTGATE OPEN WARNING CONTINUES DISPLAYING, OR DOES NOT DISPLAY

< SYMPTOM DIAGNOSIS >

1. Turn ignition switch OFF.
2. Disconnect BCM connector M19 and back door switch connector D502.
3. Check continuity between BCM harness connector M19 (A) terminal 43 and back door switch harness connector D502 (B) terminal 3.

43 - 3 : Continuity should exist.

4. Check continuity between BCM harness connector M19 (A) terminal 43 and ground.

43 - Ground : Continuity should not exist.

Is the inspection result normal?

YES >> GO TO 5

NO >> Repair harness or connector.

5. CHECK SWITCH GROUND CIRCUIT

With Power Back Door

Check continuity between back door latch harness connector D503 terminal 8 and ground.

8 - Ground : Continuity should exist.

Without Power Back Door

Check continuity between back door switch harness connector D502 terminal 1 and ground.

1 - Ground : Continuity should exist.

Is the inspection result normal?

YES >> Replace back door latch (with power back door) or back door switch (without power back door).

NO >> Repair harness or connector.

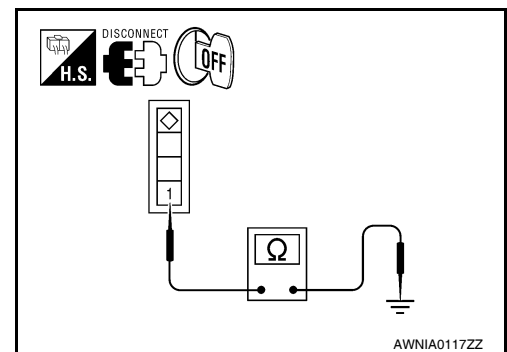
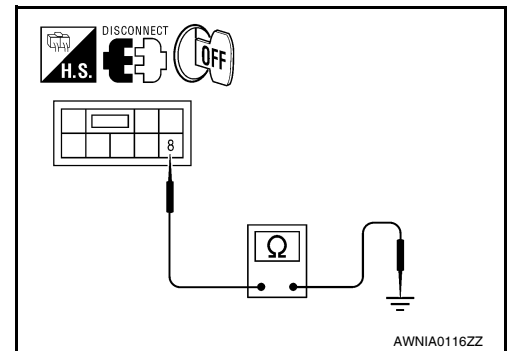
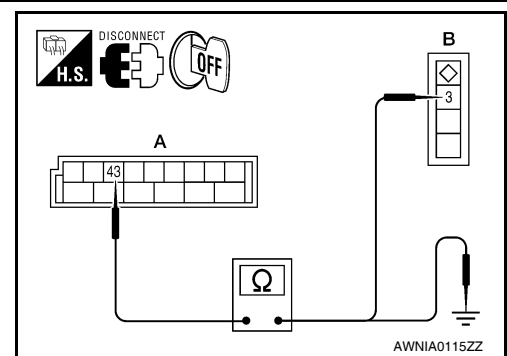

A
B
C
D
E
F
G
H
I
J
K
L
M
MWI
O
P

THE LIFTGATE GLASS OPEN WARNING CONTINUES DISPLAYING, OR DOES NOT DISPLAY

< SYMPTOM DIAGNOSIS >

THE LIFTGATE GLASS OPEN WARNING CONTINUES DISPLAYING, OR DOES NOT DISPLAY

Description

INFOID:000000004918112

- The liftgate glass open warning is displayed continuously even though the glass hatch is closed.
- The liftgate glass open warning is not displayed even though the glass hatch is open.

Diagnosis Procedure

INFOID:000000004918113

Regarding Wiring Diagram information, refer to [MWI-45, "Wiring Diagram"](#).

1. CHECK COMBINATION METER INPUT SIGNAL

1. Select "METER/M&A" on CONSULT-III.
2. Monitor "TRUNK W/L" of "DATA MONITOR" while opening and closing the glass hatch.

When glass hatch is open

TRUNK W/L : ON

When glass hatch is closed

TRUNK W/L : OFF

Is the inspection result normal?

YES >> Replace combination meter. Refer to [MWI-106, "Removal and Installation"](#).

NO >> GO TO 2

2. CHECK GLASS HATCH AJAR SWITCH INPUT SIGNAL

Check voltage between BCM connector M19 terminal 42 and ground.

Connector	Item	Terminals		Condition	Voltage (V) (Approx.)
		(+)	(-)		
M19	BCM	42	Ground	Open ↓ Closed	0 ↓ Battery voltage

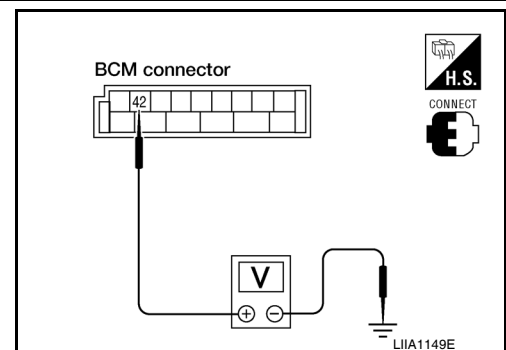

Is the inspection result normal?

YES >> Replace BCM. Refer to [BCS-60, "Removal and Installation"](#).

NO >> GO TO 3

3. CHECK GLASS HATCH AJAR SWITCH

1. Disconnect glass hatch ajar switch connector D707.
2. Check continuity between glass hatch ajar switch terminal and ground.

Glass hatch ajar switch	Terminals	Condition	Continuity
		Open	Yes
	1 - Ground	Closed	No

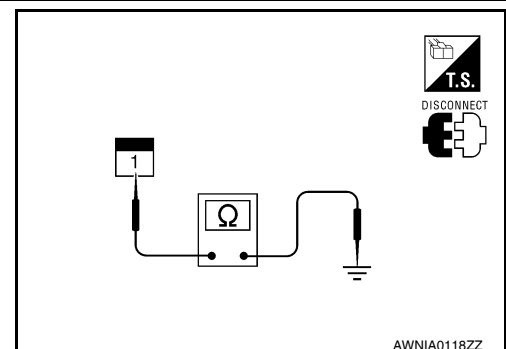

Is the inspection result normal?

YES >> Repair or replace harness between BCM and glass hatch ajar switch.

NO >> Replace glass hatch ajar switch.

NORMAL OPERATING CONDITION

< SYMPTOM DIAGNOSIS >

NORMAL OPERATING CONDITION COMPASS

COMPASS : Description

INFOID:000000004918114

COMPASS

- The electronic compass is highly protected from changes in most magnetic fields. However, some large changes in magnetic fields can affect it. Some examples are (but not limited to): high tension power lines, large steel buildings, subways, steel bridges, automatic car washes, large piles of scrap metal, etc. While this does not happen very often, it is possible.
- During normal operation, the Compass Mirror will continuously update the compass calibration to adjust for gradual changes in the vehicle's magnetic "remnant" field. If the vehicle is subjected to high magnetic influences, the compass may appear to indicate false headings, become locked, or appear that it is unable to be calibrated. If this occurs, perform the calibration procedure.
- If at any time the compass continually displays the incorrect direction or the reading is erratic or locked, verify the correct zone variance.

Symptom Chart

Symptom	Cause	Solution / Reference
The compass display reads "C".	<ul style="list-style-type: none"> • Compass is not calibrated. • Incorrect zone variance setting. • Large change in magnetic field (Steel bridges, subways, concentrations of metal, car washes, etc.) • Compass was calibrated incorrectly or in the presence of a strong magnetic field. 	Perform Calibration. Refer to MWI-24, "Description" .
Compass shows the wrong direction.		
Compass does not change direction appears "Locked".		
Compass does not show all the directions, one or more is missing.		
The compass was calibrated but it "loses" calibration.		
On long trips the compass shows the wrong direction.	Perform Zone Variation Setting if correct reading is desired in that location. Refer to MWI-24, "Description" .	

A
B
C
D
E
F
G
H
I
J
K
L
M
N
O
P



PRECAUTIONS

< PRECAUTION >

PRECAUTION

PRECAUTIONS

Precaution for Supplemental Restraint System (SRS) "AIR BAG" and "SEAT BELT PRE-TENSIONER"

INFOID:000000005156210

The Supplemental Restraint System such as "AIR BAG" and "SEAT BELT PRE-TENSIONER", used along with a front seat belt, helps to reduce the risk or severity of injury to the driver and front passenger for certain types of collision. This system includes seat belt switch inputs and dual stage front air bag modules. The SRS system uses the seat belt switches to determine the front air bag deployment, and may only deploy one front air bag, depending on the severity of a collision and whether the front occupants are belted or unbelted. Information necessary to service the system safely is included in the SR and SB section of this Service Manual.

WARNING:

- To avoid rendering the SRS inoperative, which could increase the risk of personal injury or death in the event of a collision which would result in air bag inflation, all maintenance must be performed by an authorized NISSAN/INFINITI dealer.
- Improper maintenance, including incorrect removal and installation of the SRS, can lead to personal injury caused by unintentional activation of the system. For removal of Spiral Cable and Air Bag Module, see the SR section.
- Do not use electrical test equipment on any circuit related to the SRS unless instructed to in this Service Manual. SRS wiring harnesses can be identified by yellow and/or orange harnesses or harness connectors.

PRECAUTIONS WHEN USING POWER TOOLS (AIR OR ELECTRIC) AND HAMMERS

WARNING:

- When working near the Airbag Diagnosis Sensor Unit or other Airbag System sensors with the Ignition ON or engine running, DO NOT use air or electric power tools or strike near the sensor(s) with a hammer. Heavy vibration could activate the sensor(s) and deploy the air bag(s), possibly causing serious injury.
- When using air or electric power tools or hammers, always switch the Ignition OFF, disconnect the battery, and wait at least 3 minutes before performing any service.

Precaution Necessary for Steering Wheel Rotation After Battery Disconnect

INFOID:000000005156211

NOTE:

- This Procedure is applied only to models with Intelligent Key system and NATS (NISSAN ANTI-THEFT SYSTEM).
- Remove and install all control units after disconnecting both battery cables with the ignition knob in the "LOCK" position.
- Always use CONSULT-III to perform self-diagnosis as a part of each function inspection after finishing work. If DTC is detected, perform trouble diagnosis according to self-diagnostic results.

For models equipped with the Intelligent Key system and NATS, an electrically controlled steering lock mechanism is adopted on the key cylinder.

For this reason, if the battery is disconnected or if the battery is discharged, the steering wheel will lock and steering wheel rotation will become impossible.

If steering wheel rotation is required when battery power is interrupted, follow the procedure below before starting the repair operation.

OPERATION PROCEDURE

1. Connect both battery cables.

NOTE:

Supply power using jumper cables if battery is discharged.

2. Use the Intelligent Key or mechanical key to turn the ignition switch to the "ACC" position. At this time, the steering lock will be released.
3. Disconnect both battery cables. The steering lock will remain released and the steering wheel can be rotated.
4. Perform the necessary repair operation.

PRECAUTIONS

< PRECAUTION >

5. When the repair work is completed, return the ignition switch to the "LOCK" position before connecting the battery cables. (At this time, the steering lock mechanism will engage.)
6. Perform a self-diagnosis check of all control units using CONSULT-III.

A

B

C

D

E

F

G

H

I

J

K

L

M

MWI

O

P

COMBINATION METER

< ON-VEHICLE REPAIR >

ON-VEHICLE REPAIR

COMBINATION METER

Removal and Installation

INFOID:000000004918116

REMOVAL

1. Disconnect battery negative terminal.
2. Remove the cluster lid A. Refer to [IP-14, "Removal and Installation"](#).
3. Remove the combination meter lower screws (A), using power tool.

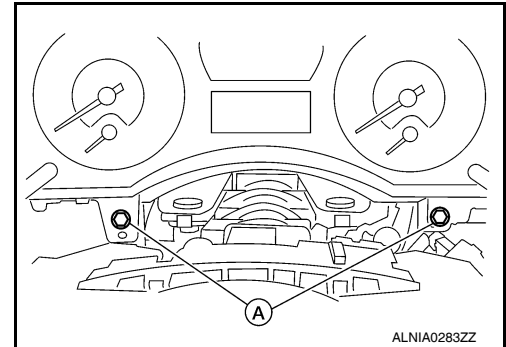

4. Remove the combination meter upper screws (A) using power tool, and pull out the combination meter (1).
5. Disconnect the combination meter connectors, and remove the combination meter (1).

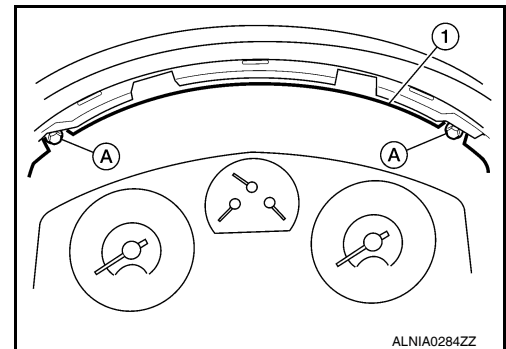

INSTALLATION

Installation is in the reverse order of removal.