

SECTION **BRC**

BRAKE CONTROL SYSTEM

A
B
C
D
E

CONTENTS

| | | |
|---|----|--|
| VDC/TCS/ABS | | |
| BASIC INSPECTION | 4 | |
| DIAGNOSIS AND REPAIR WORKFLOW | 4 | |
| Work Flow | 4 | |
| Diagnostic Work Sheet | 7 | |
| INSPECTION AND ADJUSTMENT | 8 | |
| ADDITIONAL SERVICE WHEN REPLACING CONTROL UNIT | 8 | |
| ADDITIONAL SERVICE WHEN REPLACING CONTROL UNIT : Description | 8 | |
| ADDITIONAL SERVICE WHEN REPLACING CONTROL UNIT : Special Repair Requirement | 8 | |
| ADJUSTMENT OF STEERING ANGLE SENSOR NEUTRAL POSITION | 8 | |
| ADJUSTMENT OF STEERING ANGLE SENSOR NEUTRAL POSITION : Description | 8 | |
| ADJUSTMENT OF STEERING ANGLE SENSOR NEUTRAL POSITION : Special Repair Requirement | 8 | |
| CALIBRATION OF DECEL G SENSOR | 9 | |
| CALIBRATION OF DECEL G SENSOR : Description | 9 | |
| CALIBRATION OF DECEL G SENSOR : Special Repair Requirement | 9 | |
| SYSTEM DESCRIPTION | 11 | |
| VDC | 11 | |
| System Diagram | 11 | |
| Hydraulic Circuit Diagram | 12 | |
| System Description | 12 | |
| Component Parts Location | 13 | |
| Component Description | 14 | |
| TCS | 15 | |
| System Diagram | 15 | |
| System Description | 15 | |
| Component Parts Location | 16 | |
| Component Description | 17 | |
| ABS | 18 | |
| System Diagram | 18 | |
| System Description | 18 | |
| Component Parts Location | 19 | |
| Component Description | 20 | |
| EBD | 21 | |
| System Diagram | 21 | |
| System Description | 21 | |
| Component Parts Location | 22 | |
| Component Description | 23 | |
| DIAGNOSIS SYSTEM [ABS ACTUATOR AND ELECTRIC UNIT (CONTROL UNIT)] | 24 | |
| CONSULT-III Function (ABS) | 24 | |
| DTC/CIRCUIT DIAGNOSIS | 29 | |
| C1101, C1102, C1103, C1104 WHEEL SENSOR-1 | 29 | |
| Description | 29 | |
| DTC Logic | 29 | |
| Diagnosis Procedure | 29 | |
| Component Inspection | 31 | |
| Special Repair Requirement | 31 | |
| C1105, C1106, C1107, C1108 WHEEL SENSOR-2 | 32 | |
| Description | 32 | |
| DTC Logic | 32 | |
| Diagnosis Procedure | 32 | |
| Component Inspection | 34 | |
| Special Repair Requirement | 34 | |
| C1109 POWER AND GROUND SYSTEM | 35 | |
| Description | 35 | |
| DTC Logic | 35 | |
| Diagnosis Procedure | 35 | |
| Special Repair Requirement | 36 | |

BRC

G
H
I
J
K
L
M
N
O
P

| | | | |
|---|-----------|--|-----------|
| C1110, C1170 ABS ACTUATOR AND ELECTRIC UNIT (CONTROL UNIT) | 37 | Component Inspection | 56 |
| DTC Logic | 37 | Special Repair Requirement | 56 |
| Diagnosis Procedure | 37 | C1142 PRESS SENSOR | 57 |
| Special Repair Requirement | 37 | Description | 57 |
| C1111 ABS MOTOR, MOTOR RELAY SYSTEM | 38 | DTC Logic | 57 |
| Description | 38 | Diagnosis Procedure (Front Pressure Sensor) | 57 |
| DTC Logic | 38 | Diagnosis Procedure (Rear Pressure Sensor) | 58 |
| Diagnosis Procedure | 38 | Component Inspection (Front Pressure Sensor) ... | 59 |
| Component Inspection | 39 | Component Inspection (Rear Pressure Sensor) | 59 |
| Special Repair Requirement | 39 | C1143, C1144 STEERING ANGLE SENSOR... | 60 |
| C1113, C1145, C1146 YAW RATE/SIDE/DECEL G SENSOR | 40 | Description | 60 |
| Description | 40 | DTC Logic | 60 |
| DTC Logic | 40 | Diagnosis Procedure | 60 |
| Diagnosis Procedure | 40 | Component Inspection | 61 |
| Component Inspection | 41 | Special Repair Requirement | 61 |
| Special Repair Requirement | 41 | C1155 BRAKE FLUID LEVEL SWITCH | 63 |
| C1115 WHEEL SENSOR | 42 | Description | 63 |
| Description | 42 | DTC Logic | 63 |
| DTC Logic | 42 | Diagnosis Procedure | 63 |
| Diagnosis Procedure | 42 | Component Inspection | 64 |
| Component Inspection | 43 | Special Repair Requirement | 64 |
| Special Repair Requirement | 44 | C1156 ST ANG SEN COM CIR | 66 |
| C1116 STOP LAMP SWITCH | 45 | Description | 66 |
| Description | 45 | DTC Logic | 66 |
| DTC Logic | 45 | Diagnosis Procedure | 66 |
| Diagnosis Procedure | 45 | C1160 DECEL G SEN SET | 67 |
| Special Repair Requirement | 46 | Description | 67 |
| C1120, C1122, C1124, C1126 IN ABS SOL | 47 | DTC Logic | 67 |
| Description | 47 | Diagnosis Procedure | 67 |
| DTC Logic | 47 | C1163 ST ANGLE SEN SAFE | 68 |
| Diagnosis Procedure | 47 | Description | 68 |
| Component Inspection | 48 | DTC Logic | 68 |
| Special Repair Requirement | 48 | Diagnosis Procedure | 68 |
| C1121, C1123, C1125, C1127 OUT ABS SOL.. | 50 | C1164, C1165, C1166, C1167 CV/SV SYSTEM | 69 |
| Description | 50 | Description | 69 |
| DTC Logic | 50 | DTC Logic | 69 |
| Diagnosis Procedure | 50 | Diagnosis Procedure | 69 |
| Component Inspection | 51 | Component Inspection | 70 |
| Special Repair Requirement | 51 | Special Repair Requirement | 71 |
| C1130, C1131, C1132, C1133, C1136 ENGINE SIGNAL | 53 | C1178, C1181, C1184, C1189 ABS ACTIVE BOOSTER | 72 |
| Description | 53 | Description | 72 |
| DTC Logic | 53 | DTC Logic | 72 |
| Diagnosis Procedure | 53 | Diagnosis Procedure | 72 |
| Special Repair Requirement | 53 | Component Inspection | 73 |
| C1140 ACTUATOR RLY | 55 | Special Repair Requirement | 73 |
| Description | 55 | C1179 ABS DELTA S SEN NG | 75 |
| DTC Logic | 55 | Description | 75 |
| Diagnosis Procedure | 55 | DTC Logic | 75 |
| | | Diagnosis Procedure | 75 |
| | | Component Inspection | 76 |

| | | | | |
|---|------------|---|------------|------------|
| Special Repair Requirement | 76 | Diagnosis Procedure | 102 | |
| U1000 CAN COMM CIRCUIT | 77 | UNEXPECTED PEDAL REACTION | 103 | A |
| Description | 77 | Diagnosis Procedure | 103 | |
| DTC Logic | 77 | THE BRAKING DISTANCE IS LONG | 104 | B |
| Diagnosis Procedure | 77 | Diagnosis Procedure | 104 | |
| VDC OFF SWITCH | 78 | ABS FUNCTION DOES NOT OPERATE | 105 | C |
| Description | 78 | Diagnosis Procedure | 105 | |
| Component Function Check | 78 | PEDAL VIBRATION OR ABS OPERATION | | |
| Diagnosis Procedure | 78 | SOUND OCCURS | 106 | D |
| Component Inspection | 79 | Diagnosis Procedure | 106 | |
| Special Repair Requirement | 79 | VEHICLE JERKS DURING VDC/TCS/ABS | | |
| ABS WARNING LAMP | 80 | CONTROL | 107 | E |
| Description | 80 | Diagnosis Procedure | 107 | |
| Component Function Check | 80 | NORMAL OPERATING CONDITION | 108 | BRC |
| Diagnosis Procedure | 80 | Description | 108 | |
| Special Repair Requirement | 80 | PRECAUTION | 109 | G |
| BRAKE WARNING LAMP | 81 | PRECAUTIONS | 109 | |
| Description | 81 | Precaution for Supplemental Restraint System | | |
| Component Function Check | 81 | (SRS) "AIR BAG" and "SEAT BELT PRE-TEN- | | H |
| Diagnosis Procedure | 81 | SIONER" | 109 | |
| Special Repair Requirement | 81 | Precaution Necessary for Steering Wheel Rota- | | I |
| VDC OFF INDICATOR LAMP | 82 | tion After Battery Disconnect | 109 | |
| Description | 82 | Precaution for Brake System | 110 | J |
| Component Function Check | 82 | Precaution for Brake Control | 110 | |
| Diagnosis Procedure | 82 | Precaution for CAN System | 111 | |
| Special Repair Requirement | 83 | PREPARATION | 112 | K |
| SLIP INDICATOR LAMP | 84 | PREPARATION | 112 | |
| Description | 84 | Special Service Tool | 112 | |
| Component Function Check | 84 | Commercial Service Tool | 112 | L |
| Diagnosis Procedure | 84 | UNIT REMOVAL AND INSTALLATION ... | 113 | |
| Special Repair Requirement | 84 | WHEEL SENSORS | 113 | M |
| ECU DIAGNOSIS INFORMATION | 85 | Removal and Installation | 113 | |
| ABS ACTUATOR AND ELECTRIC UNIT | | SENSOR ROTOR | 114 | N |
| (CONTROL UNIT) | 85 | Removal and Installation | 114 | |
| Reference Value | 85 | ACTUATOR AND ELECTRIC UNIT (ASSEM- | | |
| Fail-Safe | 89 | BLY) | 115 | O |
| DTC No. Index | 90 | Removal and Installation | 115 | |
| WIRING DIAGRAM | 92 | STEERING ANGLE SENSOR | 117 | P |
| BRAKE CONTROL SYSTEM - VDC | 92 | Removal and Installation | 117 | |
| Wiring Diagram | 92 | G SENSOR | 118 | |
| SYMPTOM DIAGNOSIS | 101 | Removal and Installation | 118 | |
| VDC/TCS/ABS | 101 | | | |
| Symptom Table | 101 | | | |
| EXCESSIVE ABS FUNCTION OPERATION | | | | |
| FREQUENCY | 102 | | | |

BASIC INSPECTION

DIAGNOSIS AND REPAIR WORKFLOW

Work Flow

INFOID:000000006147037

PRECAUTIONS FOR DIAGNOSIS

If steering angle sensor, steering system parts, suspension system parts, ABS actuator and electric unit (control unit) or tires have been replaced, or if wheel alignment has been adjusted, be sure to adjust neutral position of steering angle sensor before driving. Refer to [BRC-8, "ADJUSTMENT OF STEERING ANGLE SENSOR NEUTRAL POSITION : Description"](#).

DIAGNOSIS AND REPAIR WORKFLOW

< BASIC INSPECTION >

[VDC/TCS/ABS]

OVERALL SEQUENCE

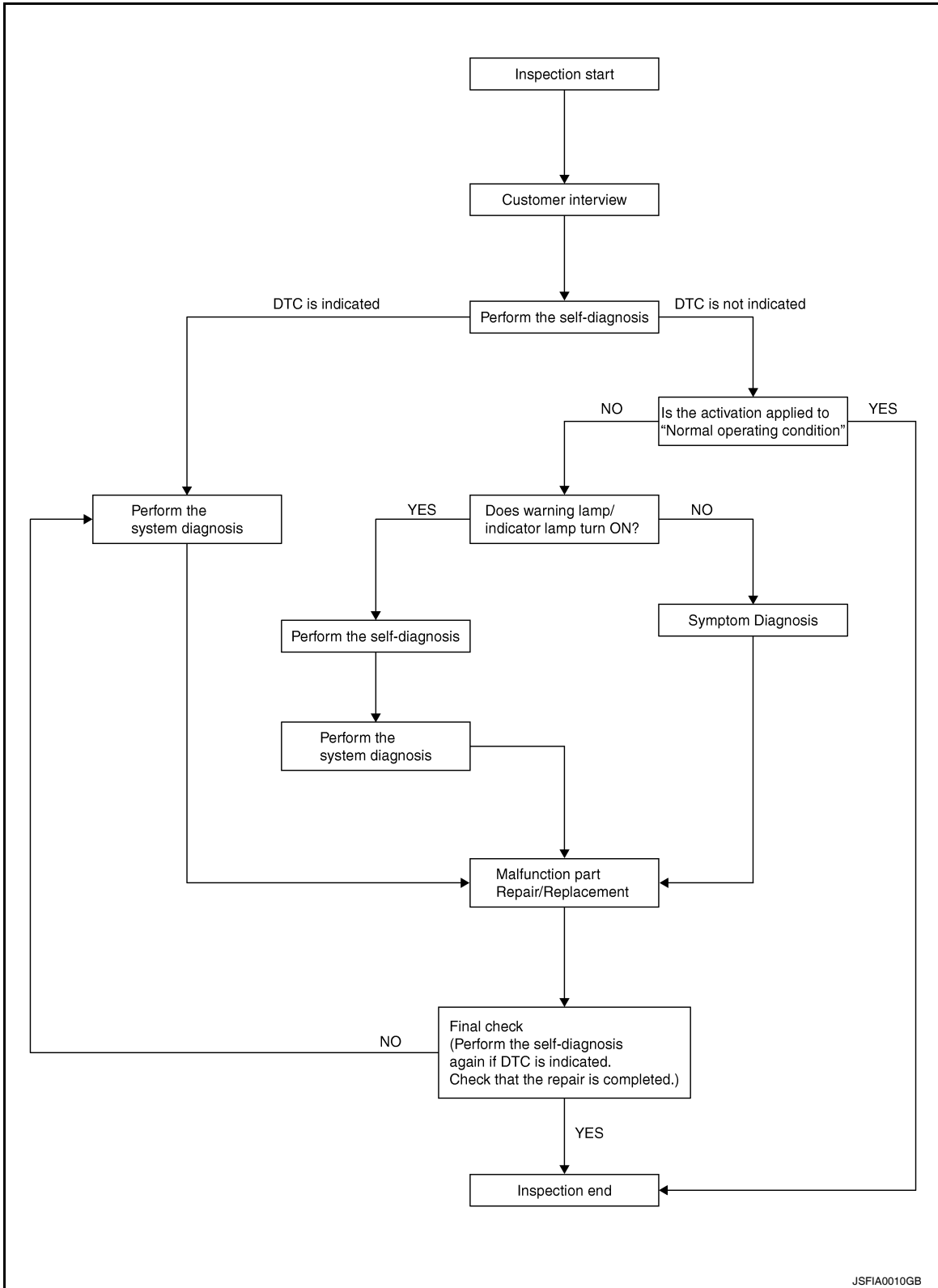

A
B
C
D
E
BRC
G
H
I
J
K
L
M
N
O
P

DETAILED FLOW

1. COLLECT THE INFORMATION FROM THE CUSTOMER

Get the detailed information from the customer about the symptom (the condition and the environment when the incident/malfunction occurred) using the diagnosis worksheet. Refer to [BRC-7, "Diagnostic Work Sheet"](#).

>> GO TO 2

DIAGNOSIS AND REPAIR WORKFLOW

[VDC/TCS/ABS]

< BASIC INSPECTION >

2. PERFORM THE SELF-DIAGNOSIS

Check the DTC display with the self-diagnosis function. Refer to [BRC-24, "CONSULT-III Function \(ABS\)"](#).

Is there any DTC displayed?

YES >> GO TO 3

NO >> GO TO 4

3. PERFORM THE SYSTEM DIAGNOSIS

Perform the diagnosis applicable to the displayed DTC. Refer to [BRC-90, "DTC No. Index"](#).

>> GO TO 7

4. CHECK THE SYMPTOM THAT IS NOT CONSIDERED A SYSTEM MALFUNCTION

Check that the symptom is a normal operation that is not considered a system malfunction. Refer to [BRC-108, "Description"](#).

Is the symptom a normal operation?

YES >> Inspection End

NO >> GO TO 5

5. CHECK THE WARNING LAMP AND INDICATOR LAMP FOR ILLUMINATION

Check that the warning lamp and indicator lamp illuminate.

- ABS warning lamp: Refer to [BRC-80, "Description"](#).
- Brake warning lamp: Refer to [BRC-81, "Description"](#).
- VDC OFF indicator lamp: Refer to [BRC-82, "Description"](#).
- SLIP indicator lamp: Refer to [BRC-84, "Description"](#).

Is ON/OFF timing normal?

YES >> GO TO 6

NO >> GO TO 2

6. PERFORM THE DIAGNOSIS BY SYMPTOM

Perform the diagnosis applicable to the symptom.

>> GO TO 7

7. REPAIR OR REPLACE THE MALFUNCTIONING PARTS

Repair or replace the specified malfunctioning parts.

>> GO TO 8

8. FINAL CHECK

Perform the self-diagnosis again, and check that the malfunction is repaired completely. After checking, erase the self-diagnosis memory. Refer to [BRC-24, "CONSULT-III Function \(ABS\)"](#).

Is no other DTC present and the repair completed?

YES >> Inspection End

NO >> GO TO 3

DIAGNOSIS AND REPAIR WORKFLOW

< BASIC INSPECTION >

[VDC/TCS/ABS]

Diagnostic Work Sheet

INFOID:000000006147038

| | | | |
|---------------------------|---|---|---|
| Customer name MR/MS | Model & Year | VIN | |
| Engine # | Trans. | Mileage | |
| Incident Date | Manuf. Date | In Service Date | |
| Symptoms | <input type="checkbox"/> Noise and vibration (from engine compartment) | <input type="checkbox"/> Warning / Indicator activate | <input type="checkbox"/> Firm pedal operation Large stroke pedal operation |
| | <input type="checkbox"/> Noise and vibration (from axle) | <input type="checkbox"/> TCS does not work (Rear wheels slip when accelerating) | <input type="checkbox"/> ABS does not work (Wheels lock when braking) |
| Engine conditions | <input type="checkbox"/> When starting <input type="checkbox"/> After starting | | |
| Road conditions | <input type="checkbox"/> Low friction road (<input type="checkbox"/> Snow <input type="checkbox"/> Gravel <input type="checkbox"/> Other) <input type="checkbox"/> Bumps / potholes | | |
| Driving conditions | <input type="checkbox"/> Full-acceleration <input type="checkbox"/> High speed cornering <input type="checkbox"/> Vehicle speed: Greater than 10 km/h (6 MPH) <input type="checkbox"/> Vehicle speed: 10 km/h (6 MPH) or less <input type="checkbox"/> Vehicle is stopped | | |
| Applying brake conditions | <input type="checkbox"/> Suddenly <input type="checkbox"/> Gradually | | |
| Other conditions | <input type="checkbox"/> Operation of electrical equipment <input type="checkbox"/> Shift change <input type="checkbox"/> Other descriptions | | |

SFIA3265E

A
B
C
D
E
BRC
G
H
I
J
K
L
M
N
O
P

INSPECTION AND ADJUSTMENT

< BASIC INSPECTION >

[VDC/TCS/ABS]

INSPECTION AND ADJUSTMENT

ADDITIONAL SERVICE WHEN REPLACING CONTROL UNIT

ADDITIONAL SERVICE WHEN REPLACING CONTROL UNIT : Description

INFOID:000000006147039

After replacing the ABS actuator and electric unit (control unit), perform the following procedures:

- Neutral position adjustment for the steering angle sensor
- Calibration of the decel G sensor

ADDITIONAL SERVICE WHEN REPLACING CONTROL UNIT : Special Repair Requirement

INFOID:000000006147040

1. PERFORM THE NEUTRAL POSITION ADJUSTMENT FOR THE STEERING ANGLE SENSOR

Perform the neutral position adjustment for the steering angle sensor.

>> Refer to [BRC-8. "ADJUSTMENT OF STEERING ANGLE SENSOR NEUTRAL POSITION : Special Repair Requirement"](#), GO TO 2

2. PERFORM CALIBRATION OF THE DECEL G SENSOR

Perform calibration of the decel G sensor.

>> Refer to [BRC-9. "CALIBRATION OF DECEL G SENSOR : Special Repair Requirement"](#).

ADJUSTMENT OF STEERING ANGLE SENSOR NEUTRAL POSITION

ADJUSTMENT OF STEERING ANGLE SENSOR NEUTRAL POSITION : Description

INFOID:000000006147041

Refer to the table below to determine if adjustment of steering angle sensor neutral position is required.

x: Required –: Not required

| Situation | Adjustment of steering angle sensor neutral position |
|---|--|
| Removing/Installing ABS actuator and electric unit (control unit) | — |
| Replacing ABS actuator and electric unit (control unit) | x |
| Removing/Installing steering angle sensor | x |
| Replacing steering angle sensor | x |
| Removing/Installing steering components | x |
| Replacing steering components | x |
| Removing/Installing suspension components | x |
| Replacing suspension components | x |
| Change tires to new ones | — |
| Tire rotation | — |
| Adjusting wheel alignment | x |
| Battery disconnection | x |

ADJUSTMENT OF STEERING ANGLE SENSOR NEUTRAL POSITION : Special Repair Requirement

INFOID:000000006147042

ADJUSTMENT OF STEERING ANGLE SENSOR NEUTRAL POSITION

CAUTION:

To adjust neutral position of steering angle sensor, make sure to use CONSULT-III (Adjustment cannot be done without CONSULT-III)

1. ALIGN THE VEHICLE STATUS

Stop vehicle with front wheels in straight-ahead position.

>> GO TO 2

2. PERFORM THE NEUTRAL POSITION ADJUSTMENT FOR THE STEERING ANGLE SENSOR

1. On the CONSULT-III screen, touch "WORK SUPPORT" and "ST ANGLE SENSOR ADJUSTMENT" in order.
2. Touch "START".
CAUTION:
Do not touch steering wheel while adjusting steering angle sensor.
3. After approximately 10 seconds, touch "END".
NOTE:
After approximately 60 seconds, it ends automatically.
4. Turn ignition switch OFF, then turn it ON again.
CAUTION:
Be sure to perform above operation.

>> GO TO 3

3. CHECK DATA MONITOR

1. Run vehicle with front wheels in straight-ahead position, then stop.
2. Select "DATA MONITOR". Then make sure "STR ANGLE SIG" is within $0 \pm 2.5^\circ$.

Is the steering angle within the specified range?

YES >> GO TO 4

NO >> Perform the neutral position adjustment for the steering angle sensor again, GO TO 1

4. ERASE THE SELF-DIAGNOSIS MEMORY

- Erase the self-diagnosis memory of the ABS actuator and electric unit (control unit) and ECM.
- ABS actuator and electric unit (control unit): Refer to [BRC-24, "CONSULT-III Function \(ABS\)"](#).
 - ECM: Refer to [EC-50, "CONSULT-III Function"](#).

Are the memories erased?

YES >> Inspection End

NO >> Check the items indicated by the self-diagnosis.

CALIBRATION OF DECEL G SENSOR

CALIBRATION OF DECEL G SENSOR : Description

INFOID:000000006147043

Refer to the table below to determine if calibration of the decel G sensor is required.

x: Required –: Not required

| Situation | Calibration of decel G sensor |
|---|-------------------------------|
| Removing/Installing ABS actuator and electric unit (control unit) | — |
| Replacing ABS actuator and electric unit (control unit) | x |
| Removing/Installing steering angle sensor | x |
| Replacing steering angle sensor | x |
| Removing/Installing steering components | x |
| Replacing steering components | x |
| Removing/Installing suspension components | x |
| Replacing suspension components | x |
| Change tires to new ones | — |
| Tire rotation | — |
| Adjusting wheel alignment | x |

CALIBRATION OF DECEL G SENSOR : Special Repair Requirement

INFOID:000000006147044

CALIBRATION OF DECEL G SENSOR

CAUTION:

INSPECTION AND ADJUSTMENT

[VDC/TCS/ABS]

< BASIC INSPECTION >

To calibrate the decel G sensor, make sure to use CONSULT-III
(Calibration cannot be done without CONSULT-III)

1. ALIGN THE VEHICLE STATUS

Stop vehicle with front wheels in straight-ahead position.

>> GO TO 2

2. PERFORM CALIBRATION OF DECEL G SENSOR

1. On the CONSULT-III screen, touch "WORK SUPPORT" and "DECEL G SEN CALIBRATION" in order.
2. Touch "START".
3. After approximately 10 seconds, touch "END".

NOTE:

After approximately 60 seconds, it ends automatically.

4. Turn ignition switch OFF, then turn it ON again.

CAUTION:

Be sure to perform above operation.

>> GO TO 3

3. CHECK DATA MONITOR

1. Run vehicle with front wheels in straight-ahead position, then stop.
2. Select "DATA MONITOR". Then make sure "DECEL G SEN" is within $\pm 0.08G$.

Is the inspection result normal?

YES >> GO TO 4

NO >> Perform calibration of decel G sensor again, GO TO 1

4. ERASE THE SELF-DIAGNOSIS MEMORY

Erase the self-diagnosis memory of the ABS actuator and electric unit (control unit) and ECM.

- ABS actuator and electric unit (control unit): Refer to [BRC-24, "CONSULT-III Function \(ABS\)"](#).
- ECM: Refer to [EC-50, "CONSULT-III Function"](#).

Are the memories erased?

YES >> Inspection End

NO >> Check the items indicated by the self-diagnosis.

SYSTEM DESCRIPTION

VDC

System Diagram

INFOID:000000006147045

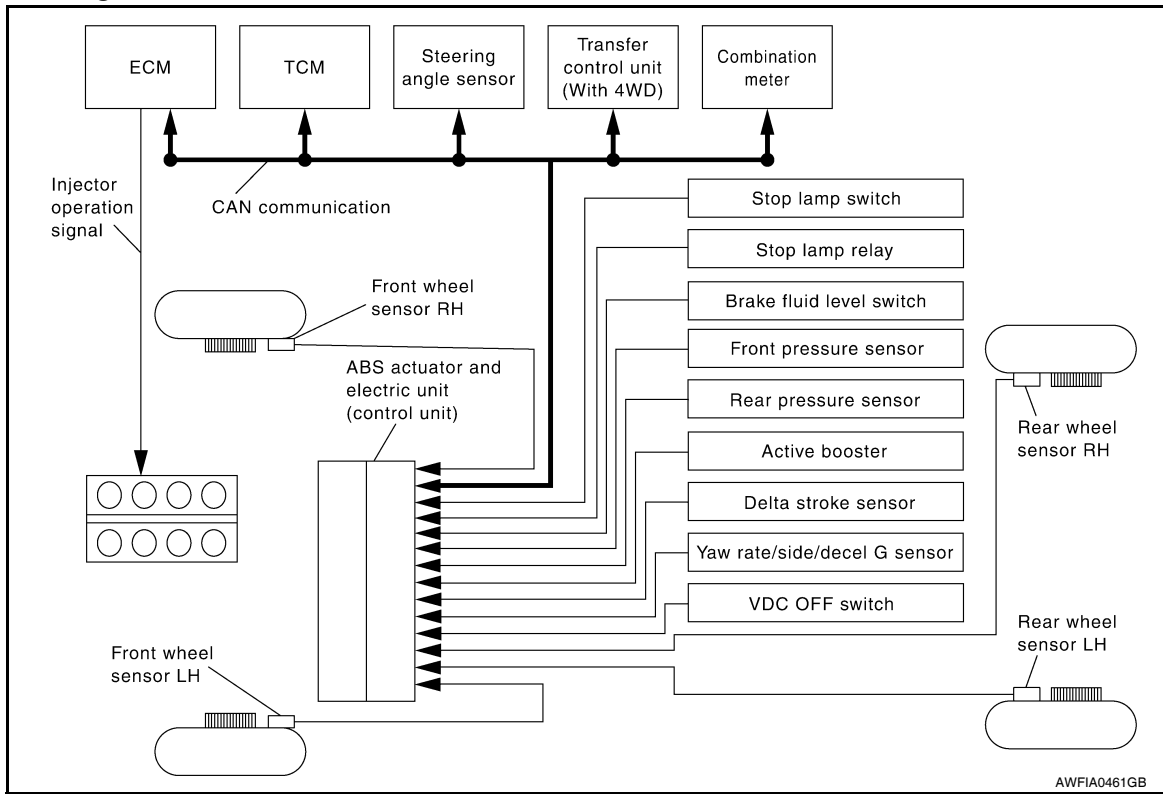

A
B
C
D
E
BRC
G
H
I
J
K
L
M
N
O
P

Hydraulic Circuit Diagram

INFOID:000000006147046

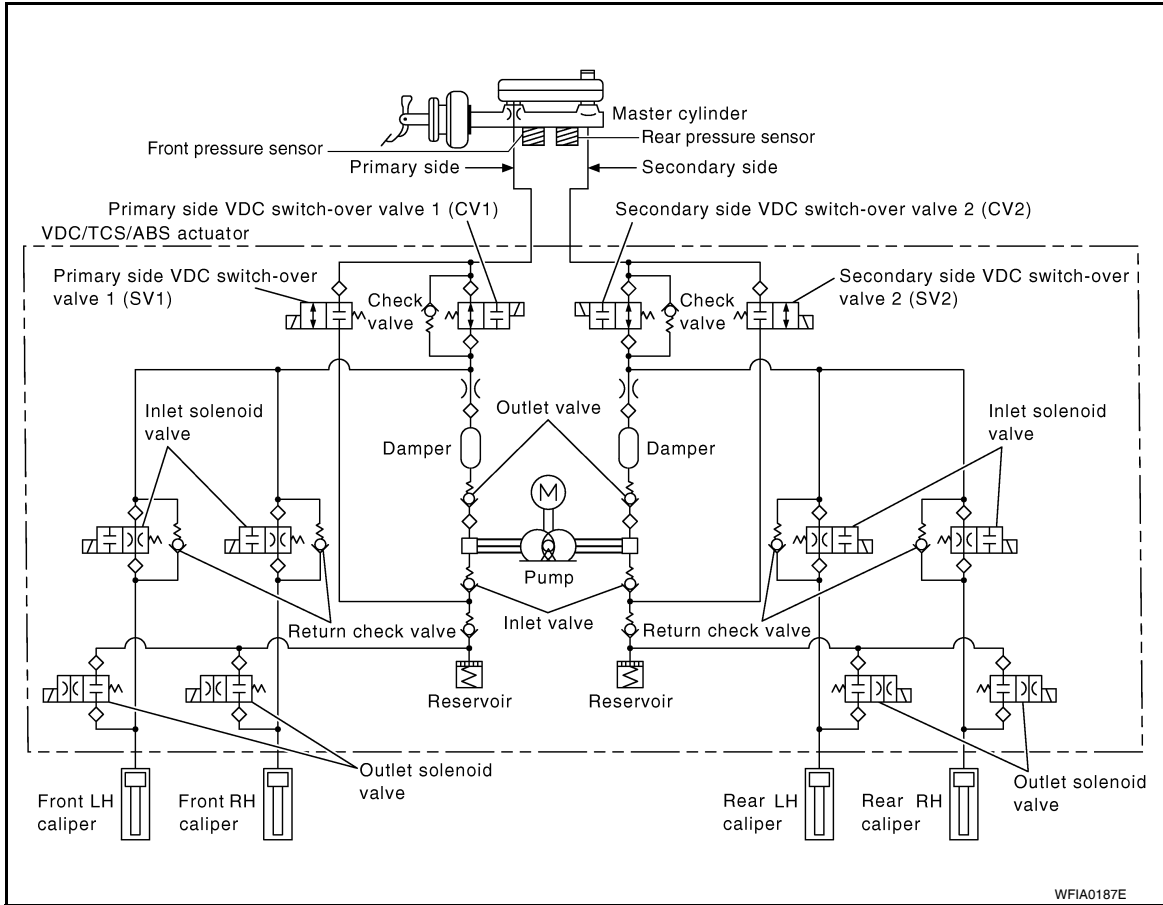

WFIA0187E

System Description

INFOID:000000006147047

- Vehicle Dynamics Control system detects driver's steering operation amount and brake pedal travel from steering angle sensor and pressure sensors. Using information from yaw rate/side/decel G sensor and wheel sensor, VDC judges driving condition (conditions of under steer and over steer) to improve vehicle driving stability by controlling brake application to 4 wheels and engine output.
- During VDC operation, it informs driver of system operation by flashing SLIP indicator lamp.
- Electrical system diagnosis by CONSULT-III is available.

< SYSTEM DESCRIPTION >
Component Parts Location

INFOID:00000006147048

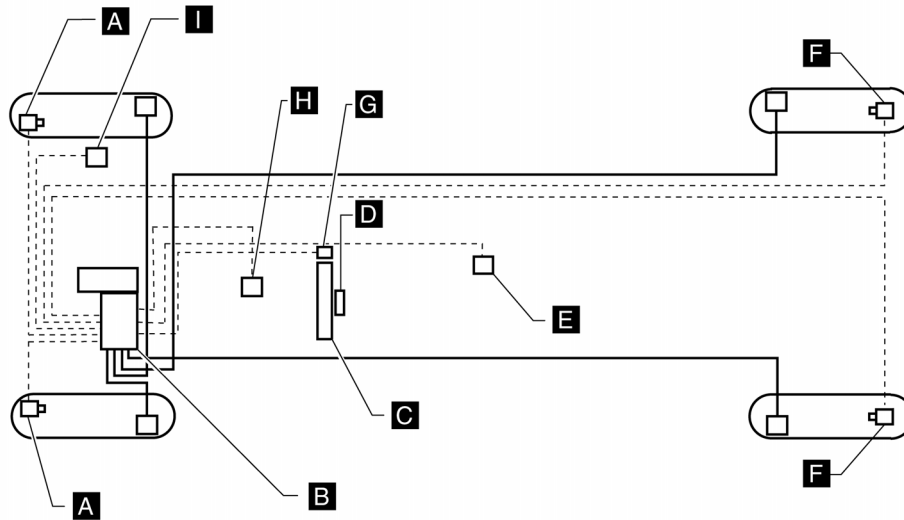

A
B
C
D
E
BRC

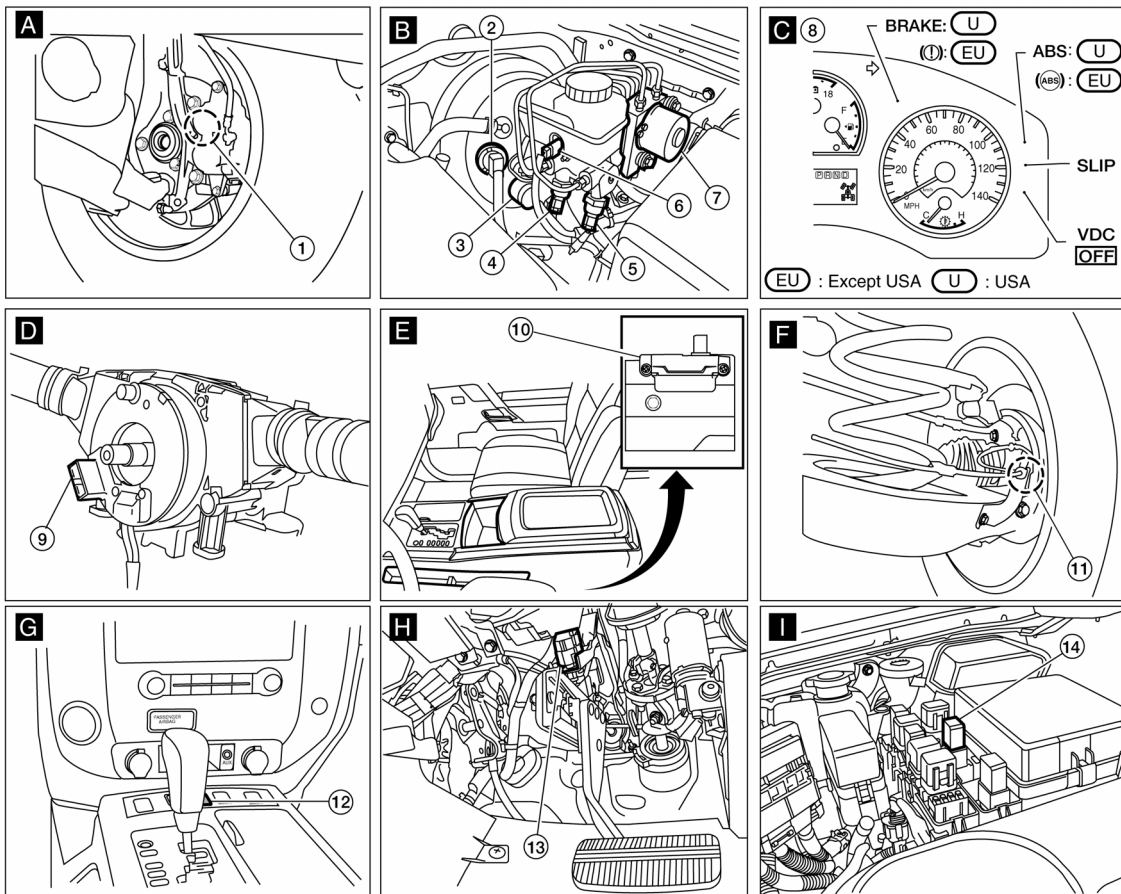

G
H
I
J
K
L
M
N
O
P

AWFIA0740ZZ

- | | | |
|--|-----------------------------|---|
| 1. Front wheel sensor LH E18 Front wheel sensor RH E117 | 2. Delta stroke sensor E114 | 3. Active booster E49 |
| 4. Front pressure sensor E31 | 5. Rear pressure sensor E32 | 6. Brake fluid level switch E21 |
| 7. ABS actuator and electric unit (control unit) E125 | 8. Combination meter M24 | 9. Steering angle sensor M17 (view with steering wheel removed) |

- | | | |
|---------------------------------------|--|-------------------------|
| 10. Yaw rate/side/decel G sensor M108 | 11. Rear wheel sensor LH C11 Rear wheel sensor RH C10 | 12. VDC OFF switch M253 |
| 13. Stop lamp switch E38 | 14. Stop lamp relay E12 | |

Component Description

INFOID:000000006147049

| Component parts | | Reference |
|---|--|---------------------------------------|
| ABS actuator and electric unit (control unit) | Pump | BRC-38. "Description" |
| | Motor | |
| | Actuator relay | BRC-55. "Description" |
| | Solenoid valve | BRC-47. "Description" |
| | VDC switch-over valve (CV1, CV2, SV1, SV2) | BRC-69. "Description" |
| Wheel sensor | BRC-29. "Description" | |
| Yaw rate/side/decel G sensor | BRC-40. "Description" | |
| Stop lamp switch | BRC-45. "Description" | |
| Front pressure sensor | BRC-57. "Description" | |
| Rear pressure sensor | | |
| Steering angle sensor | BRC-60. "Description" | |
| Brake fluid level switch | BRC-63. "Description" | |
| Active booster | BRC-72. "Description" | |
| Delta stroke sensor | BRC-75. "Description" | |
| VDC OFF switch | BRC-78. "Description" | |
| ABS warning lamp | BRC-80. "Description" | |
| Brake warning lamp | BRC-81. "Description" | |
| VDC OFF indicator lamp | BRC-82. "Description" | |
| SLIP indicator lamp | BRC-84. "Description" | |

TCS

System Diagram

INFOID:000000006570201

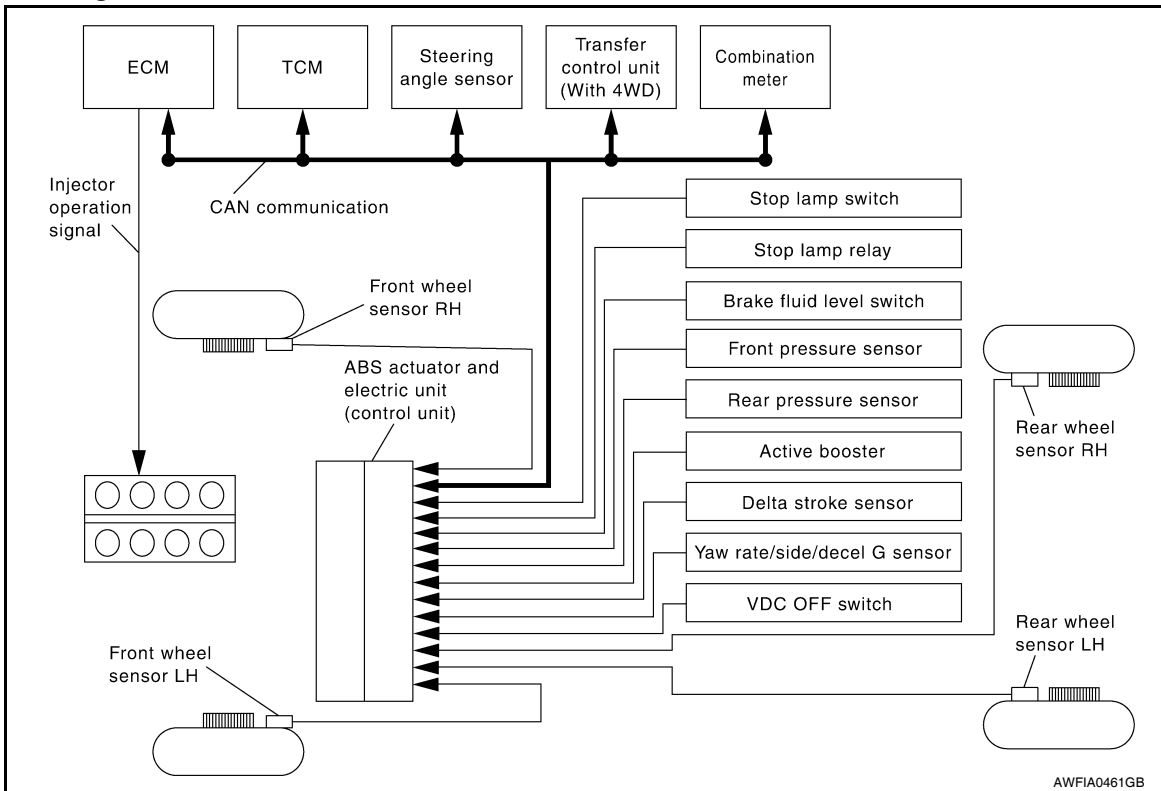

A
B
C
D
E
BRC
G
H
I
J
K
L
M
N
O
P

System Description

INFOID:000000006147051

- Traction Control System is a function that electronically controls engine torque, brake fluid pressure and A/T gear position to ensure the optimum slippage ratio at drive wheels by computing wheel speed signals from 4 wheel sensors. When ABS actuator and electric unit (control unit) detects a spin at drive wheels (rear wheels), it compares wheel speed signals from all 4 wheels. At this time, LH and RH rear brake fluid pressure are controlled, while fuel being cut to engine and throttle valve being closed to reduce engine torque by the control unit. Further more, throttle position is continuously controlled to ensure the optimum engine torque at all times.
- During TCS operation, it informs driver of system operation by flashing SLIP indicator lamp.
- Electrical system diagnosis by CONSULT-III is available.

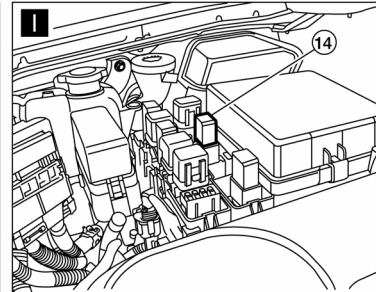
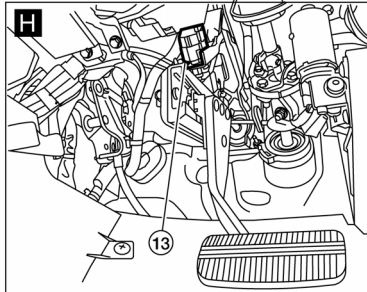
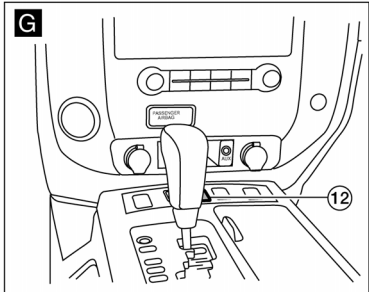
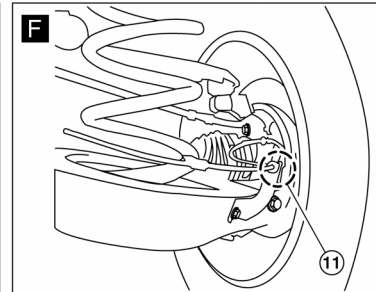
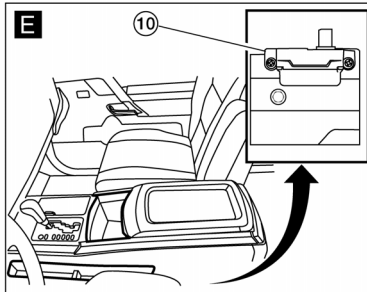
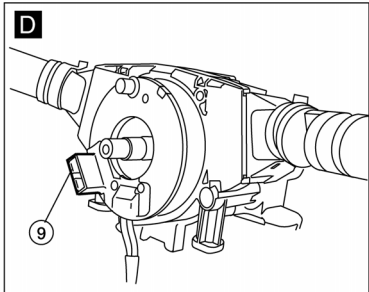
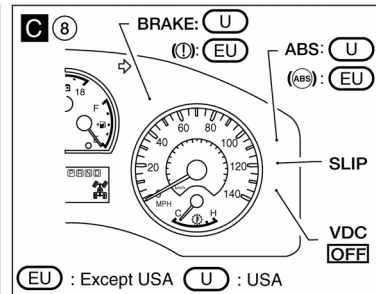
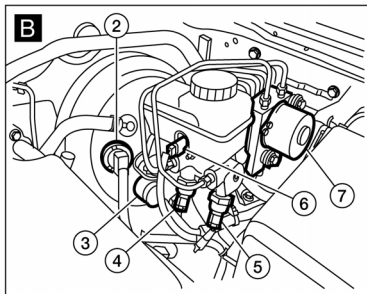
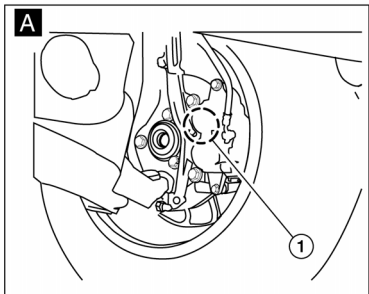
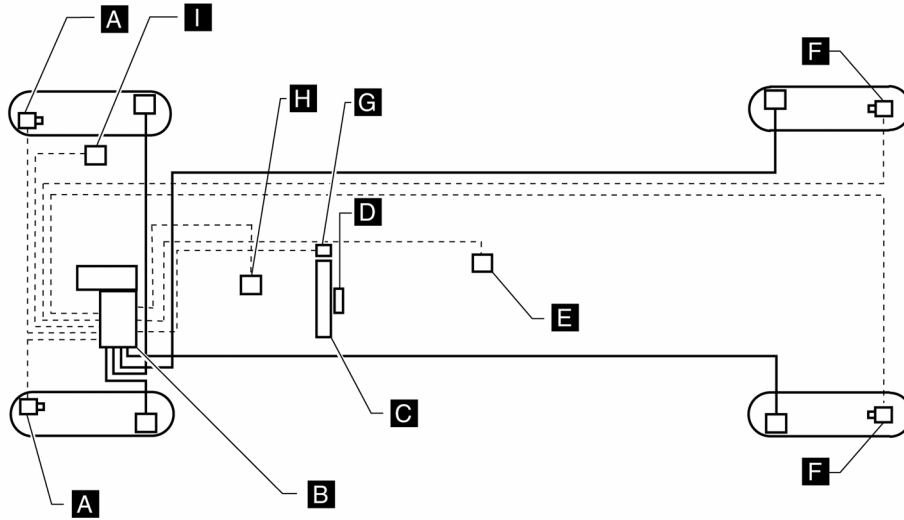

AWFIA0740ZZ

- | | | |
|--|-----------------------------|---|
| 1. Front wheel sensor LH E18 Front wheel sensor RH E117 | 2. Delta stroke sensor E114 | 3. Active booster E49 |
| 4. Front pressure sensor E31 | 5. Rear pressure sensor E32 | 6. Brake fluid level switch E21 |
| 7. ABS actuator and electric unit (control unit) E125 | 8. Combination meter M24 | 9. Steering angle sensor M17 (view with steering wheel removed) |

< SYSTEM DESCRIPTION >

- 10. Yaw rate/side/decel G sensor M108
- 11. Rear wheel sensor LH C11
Rear wheel sensor RH C10
- 12. VDC OFF switch M253
- 13. Stop lamp switch E38
- 14. Stop lamp relay E12

A
B
C
D
E
BRC
G
H
I
J
K
L
M
N
O
P

Component Description

INFOID:000000006570205

| Component parts | | Reference |
|---|--|---------------------------------------|
| ABS actuator and electric unit (control unit) | Pump | BRC-38, "Description" |
| | Motor | |
| | Actuator relay | BRC-55, "Description" |
| | Solenoid valve | BRC-47, "Description" |
| | VDC switch-over valve (CV1, CV2, SV1, SV2) | BRC-69, "Description" |
| Wheel sensor | BRC-29, "Description" | |
| Yaw rate/side/decel G sensor | BRC-40, "Description" | |
| Stop lamp switch | BRC-45, "Description" | |
| Front pressure sensor | BRC-57, "Description" | |
| Rear pressure sensor | | |
| Steering angle sensor | BRC-60, "Description" | |
| Brake fluid level switch | BRC-63, "Description" | |
| Active booster | BRC-72, "Description" | |
| Delta stroke sensor | BRC-75, "Description" | |
| VDC OFF switch | BRC-78, "Description" | |
| ABS warning lamp | BRC-80, "Description" | |
| Brake warning lamp | BRC-81, "Description" | |
| VDC OFF indicator lamp | BRC-82, "Description" | |
| SLIP indicator lamp | BRC-84, "Description" | |

ABS

System Diagram

INFOID:000000006570202

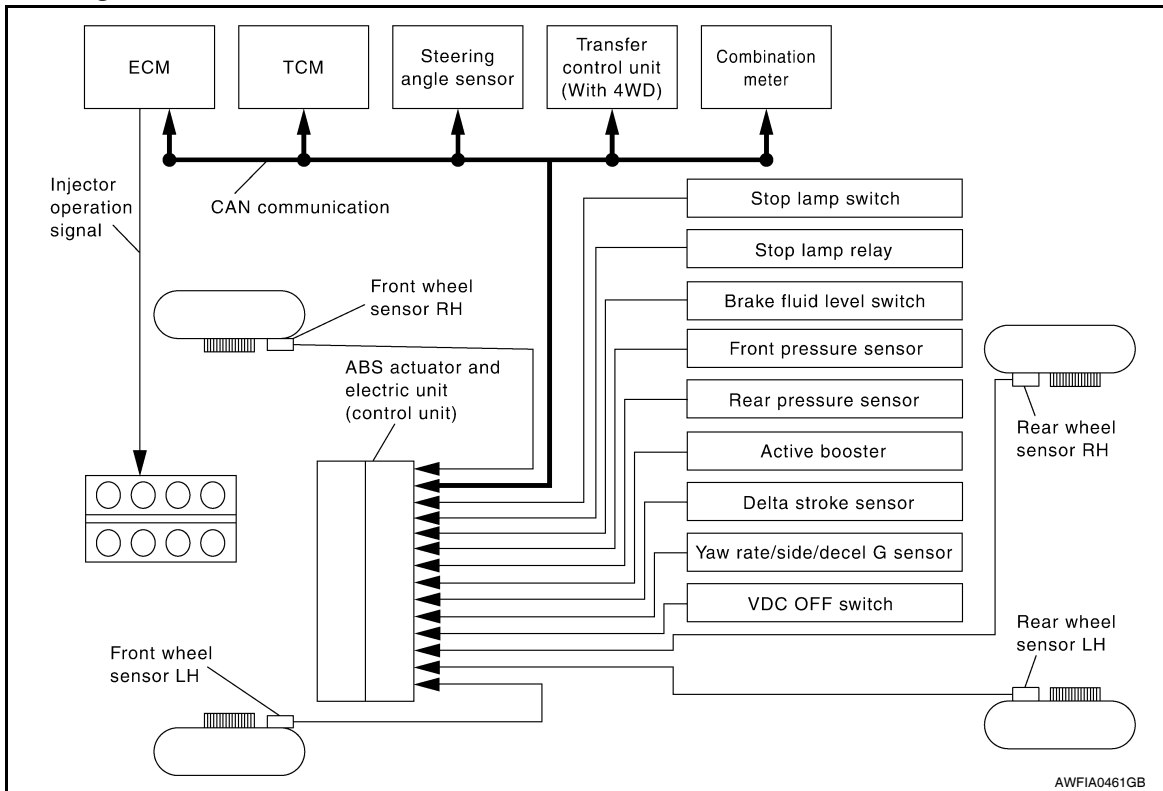

System Description

INFOID:000000006147055

- Anti-Lock Braking System is a function that detects wheel revolution while braking, electronically controls braking force, and prevents wheel locking during sudden braking. It improves handling stability and maneuverability for avoiding obstacles.
- Electrical system diagnosis by CONSULT-III is available.

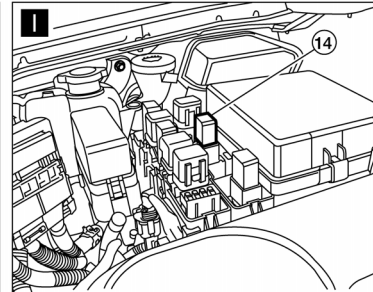
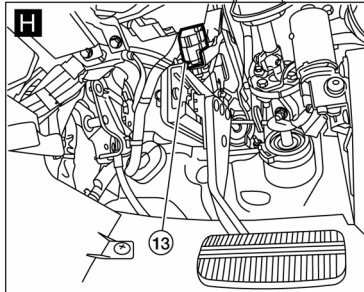
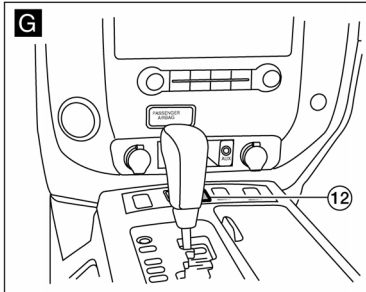
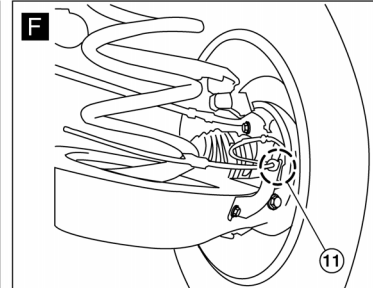
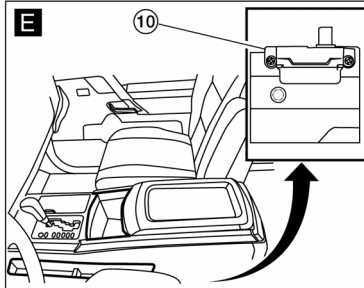
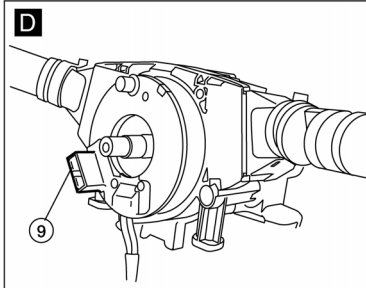
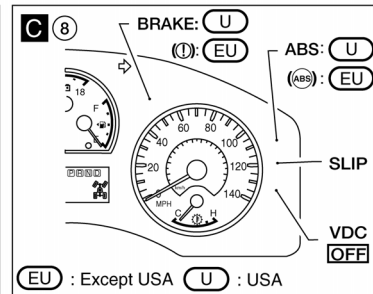
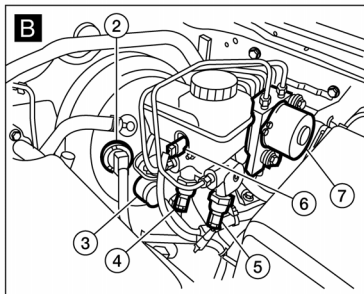
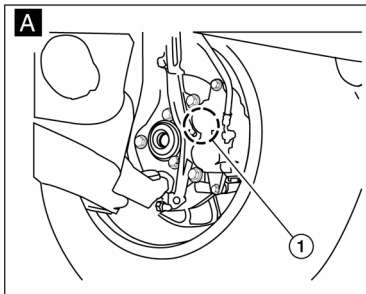
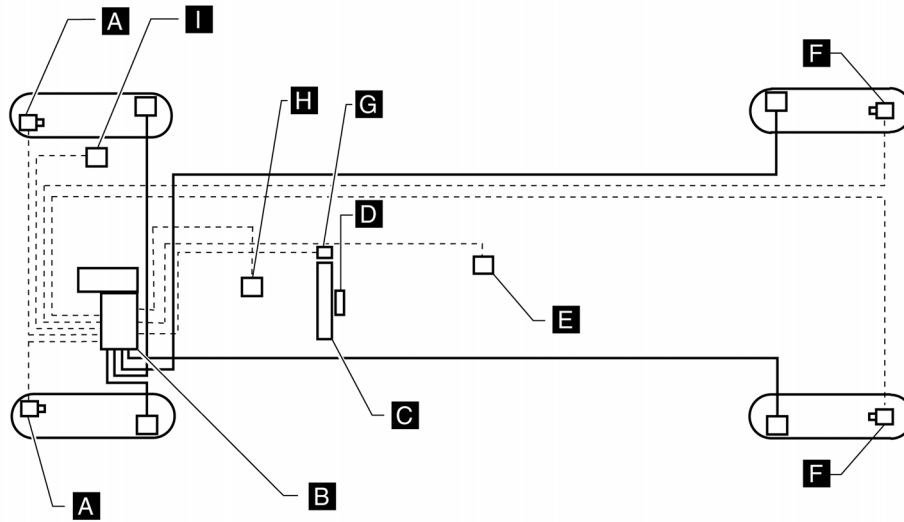

- | | | |
|--|-----------------------------|---|
| 1. Front wheel sensor LH E18 Front wheel sensor RH E117 | 2. Delta stroke sensor E114 | 3. Active booster E49 |
| 4. Front pressure sensor E31 | 5. Rear pressure sensor E32 | 6. Brake fluid level switch E21 |
| 7. ABS actuator and electric unit (control unit) E125 | 8. Combination meter M24 | 9. Steering angle sensor M17 (view with steering wheel removed) |

AWFIA0740ZZ

ABS

< SYSTEM DESCRIPTION >

[VDC/TCS/ABS]

- | | | |
|---------------------------------------|--|-------------------------|
| 10. Yaw rate/side/decel G sensor M108 | 11. Rear wheel sensor LH C11 Rear wheel sensor RH C10 | 12. VDC OFF switch M253 |
| 13. Stop lamp switch E38 | 14. Stop lamp relay E12 | |

Component Description

INFOID:000000006570207

| Component parts | | Reference |
|---|---|---------------------------------------|
| ABS actuator and electric unit (control unit) | Pump | BRC-38. "Description" |
| | Motor | |
| | Actuator relay | BRC-55. "Description" |
| | Solenoid valve | BRC-47. "Description" |
| | VDC switch-over valve (CV1, CV2, SV1, SV2) | BRC-69. "Description" |
| Wheel sensor | BRC-29. "Description" | |
| Yaw rate/side/decel G sensor | BRC-40. "Description" | |
| Stop lamp switch | BRC-45. "Description" | |
| Front pressure sensor | BRC-57. "Description" | |
| Rear pressure sensor | | |
| Steering angle sensor | BRC-60. "Description" | |
| Brake fluid level switch | BRC-63. "Description" | |
| Active booster | BRC-72. "Description" | |
| Delta stroke sensor | BRC-75. "Description" | |
| VDC OFF switch | BRC-78. "Description" | |
| ABS warning lamp | BRC-80. "Description" | |
| Brake warning lamp | BRC-81. "Description" | |
| VDC OFF indicator lamp | BRC-82. "Description" | |
| SLIP indicator lamp | BRC-84. "Description" | |

EBD

System Diagram

INFOID:000000006570203

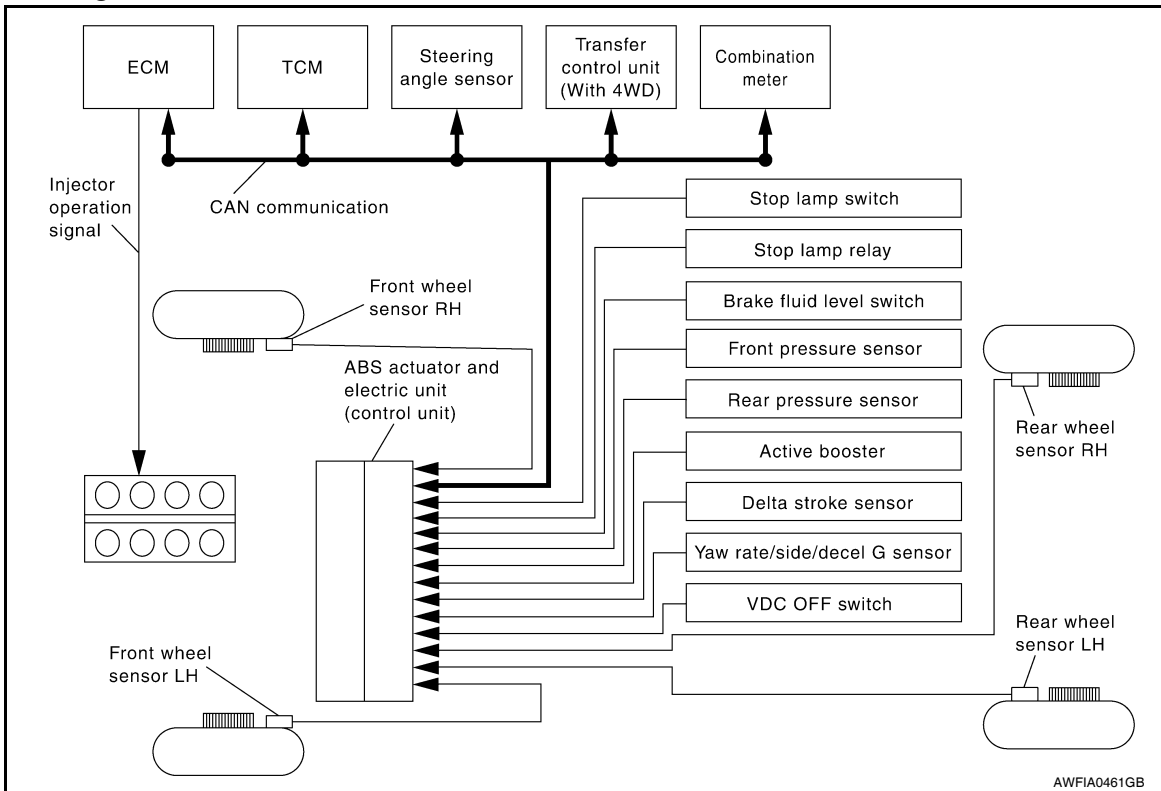

A
B
C
D
E
BRC
G
H
I
J
K
L
M
N
O
P

System Description

INFOID:000000006147059

- Electric Brake force Distribution is a following function. ABS actuator and electric unit (control unit) detects subtle slippages between the front and rear wheels during braking. Then it electronically controls the rear braking force (brake fluid pressure) to reduce rear wheel slippage. Accordingly, it improves vehicle stability.
- Electrical system diagnosis by CONSULT-III is available.

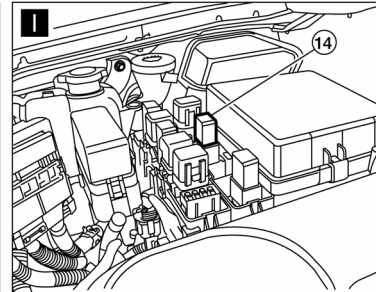
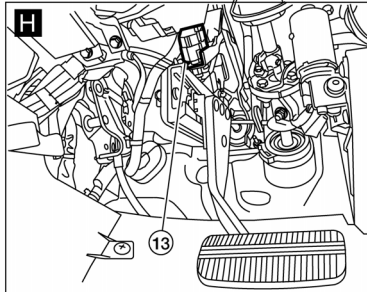
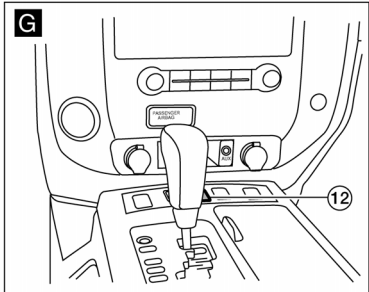
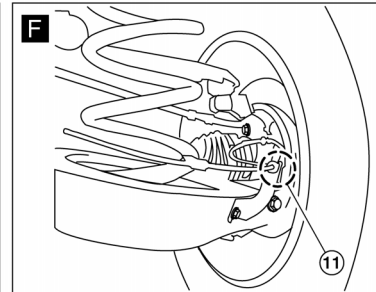
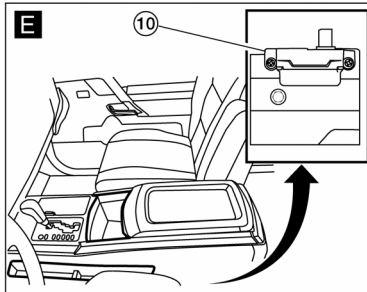
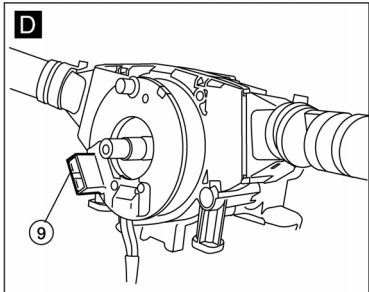
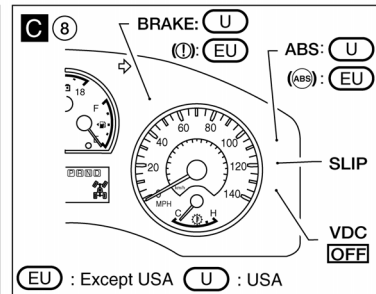
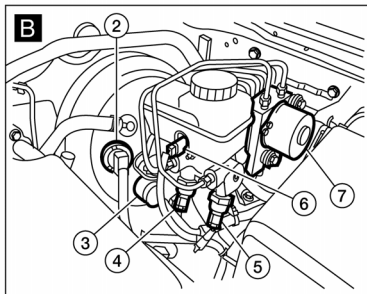
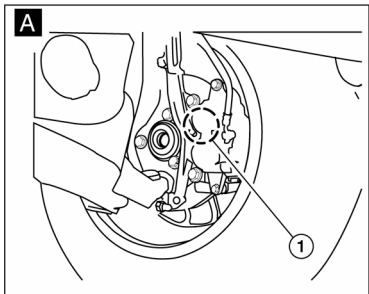
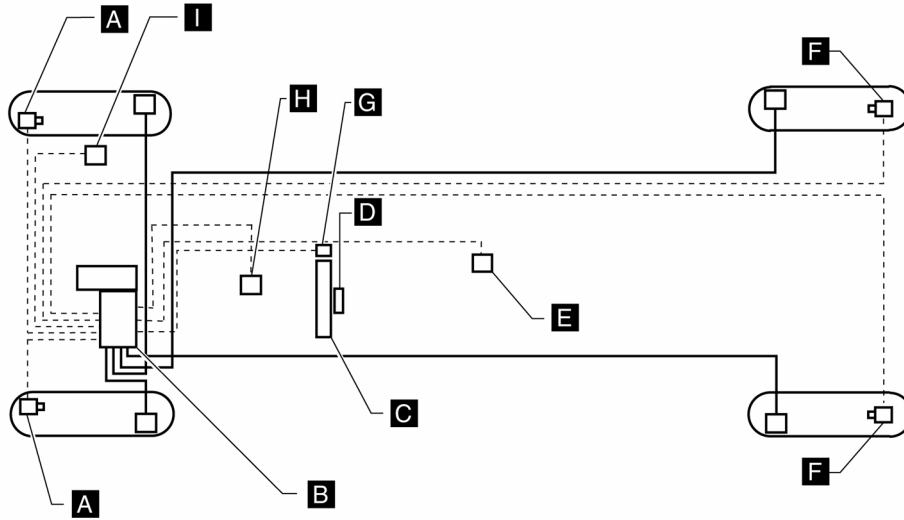

AWFIA0740ZZ

- | | | |
|--|-----------------------------|---|
| 1. Front wheel sensor LH E18 Front wheel sensor RH E117 | 2. Delta stroke sensor E114 | 3. Active booster E49 |
| 4. Front pressure sensor E31 | 5. Rear pressure sensor E32 | 6. Brake fluid level switch E21 |
| 7. ABS actuator and electric unit (control unit) E125 | 8. Combination meter M24 | 9. Steering angle sensor M17 (view with steering wheel removed) |

< SYSTEM DESCRIPTION >

- 10. Yaw rate/side/decel G sensor M108
- 11. Rear wheel sensor LH C11
Rear wheel sensor RH C10
- 12. VDC OFF switch M253
- 13. Stop lamp switch E38
- 14. Stop lamp relay E12

A
B
C
D
E
BRC
G
H
I
J
K
L
M
N
O
P

Component Description

INFOID:000000006570209

| Component parts | | Reference |
|---|--|---------------------------------------|
| ABS actuator and electric unit (control unit) | Pump | BRC-38, "Description" |
| | Motor | |
| | Actuator relay | BRC-55, "Description" |
| | Solenoid valve | BRC-47, "Description" |
| | VDC switch-over valve (CV1, CV2, SV1, SV2) | BRC-69, "Description" |
| Wheel sensor | BRC-29, "Description" | |
| Yaw rate/side/decel G sensor | BRC-40, "Description" | |
| Stop lamp switch | BRC-45, "Description" | |
| Front pressure sensor | BRC-57, "Description" | |
| Rear pressure sensor | | |
| Steering angle sensor | BRC-60, "Description" | |
| Brake fluid level switch | BRC-63, "Description" | |
| Active booster | BRC-72, "Description" | |
| Delta stroke sensor | BRC-75, "Description" | |
| VDC OFF switch | BRC-78, "Description" | |
| ABS warning lamp | BRC-80, "Description" | |
| Brake warning lamp | BRC-81, "Description" | |
| VDC OFF indicator lamp | BRC-82, "Description" | |
| SLIP indicator lamp | BRC-84, "Description" | |

DIAGNOSIS SYSTEM [ABS ACTUATOR AND ELECTRIC UNIT (CONTROL UNIT)]

< SYSTEM DESCRIPTION >

[VDC/TCS/ABS]

DIAGNOSIS SYSTEM [ABS ACTUATOR AND ELECTRIC UNIT (CONTROL UNIT)]

CONSULT-III Function (ABS)

INFOID:000000006147062

FUNCTION

CONSULT-III can display each diagnostic item using the following direct diagnostic modes.

| Direct Diagnostic Mode | Description |
|--------------------------|--|
| ECU Identification | The ABS actuator and electric unit (control unit) part number is displayed. |
| Self Diagnostic Result | Displays the diagnosis results judged by ABS actuator and electric unit (control unit). |
| Data Monitor | The ABS actuator and electric unit (control unit) input/output signals are displayed. |
| Active Test | The signals used to activate each device are forcibly supplied from ABS actuator and electric unit (control unit). |
| Function Test | This mode is used to inform customers when the vehicle requires periodic maintenance. |
| Work support | Changes the setting for each system function. |
| CAN Diag Support Monitor | Monitors the reception status of CAN communication viewed from ABS actuator and electric unit (control unit). |

SELF DIAGNOSTIC RESULT

Operation Procedure

1. Before performing the self-diagnosis, start engine and drive vehicle at 30 km/h (19 MPH) or more for approximately 1 minute.

How to Erase Self Diagnostic Result

1. After erasing DTC memory, start engine and drive vehicle at 30 km/h (19 MPH) or more for approximately 1 minute as the final inspection, and make sure that the ABS warning lamp, VDC OFF indicator lamp, SLIP indicator lamp and brake warning lamp turn OFF.

CAUTION:

If memory cannot be erased, perform applicable diagnosis.

NOTE:

- When the wheel sensor malfunctions, after inspecting the wheel sensor system, the ABS warning lamp, VDC OFF indicator lamp, SLIP indicator lamp and brake warning lamp will not turn OFF even when the system is normal unless the vehicle is driving at approximately 30 km/h (19 MPH) or more for approximately 1 minute.
- Brake warning lamp will turn ON in case of parking brake operation (when switch is ON) or of brake fluid level switch operation (when brake fluid is insufficient).
- VDC OFF switch should not stay "ON" position.

Display Item List

Refer to [BRC-90. "DTC No. Index"](#).

DATA MONITOR

| Item (Unit) | Data monitor item selection | | | Remarks |
|-----------------------------|-----------------------------|-----------------|------------------------|--|
| | ECU INPUT SIGNALS | MAIN SIGNALS | SELECTION FROM MENU | |
| FR LH SENSOR (km/h, mph) | × | × | × | Wheel speed (km/h, mph) calculated by front LH wheel sensor signal is displayed. |
| FR RH SENSOR (km/h, mph) | × | × | × | Wheel speed (km/h, mph) calculated by front RH wheel sensor signal is displayed. |
| RR LH SENSOR (km/h, mph) | × | × | × | Wheel speed (km/h, mph) calculated by rear LH wheel sensor signal is displayed. |
| RR RH SENSOR (km/h, mph) | × | × | × | Wheel speed (km/h, mph) calculated by rear RH wheel sensor signal is displayed. |

DIAGNOSIS SYSTEM [ABS ACTUATOR AND ELECTRIC UNIT (CONTROL UNIT)]

< SYSTEM DESCRIPTION >

[VDC/TCS/ABS]

| Item (Unit) | Data monitor item selection | | | Remarks |
|-------------------------|-----------------------------|--------------|---------------------|---|
| | ECU INPUT SIGNALS | MAIN SIGNALS | SELECTION FROM MENU | |
| DECEL G-SEN (G) | × | × | × | Longitudinal acceleration (G) detected by decel G-sensor is displayed. |
| FR RH IN SOL (On/Off) | - | × | × | Front RH IN ABS solenoid (On/Off) status is displayed. |
| FR RH OUT SOL (On/Off) | - | × | × | Front RH OUT ABS solenoid (On/Off) status is displayed. |
| FR LH IN SOL (On/Off) | - | × | × | Front LH IN ABS solenoid (On/Off) status is displayed. |
| FR LH OUT SOL (On/Off) | - | × | × | Front LH OUT ABS solenoid (On/Off) status is displayed. |
| RR RH IN SOL (On/Off) | - | × | × | Rear RH IN ABS solenoid (On/Off) status is displayed. |
| RR RH OUT SOL (On/Off) | - | × | × | Rear RH OUT ABS solenoid (On/Off) status is displayed. |
| RR LH IN SOL (On/Off) | - | × | × | Rear LH IN ABS solenoid (On/Off) status is displayed. |
| RR LH OUT SOL (On/Off) | - | × | × | Rear LH OUT ABS solenoid (On/Off) status is displayed. |
| EBD WARN LAMP (On/Off) | - | - | × | Brake warning lamp (On/Off) status is displayed. |
| STOP LAMP SW (On/Off) | × | × | × | Stop lamp switch (On/Off) status is displayed. |
| MOTOR RELAY (On/Off) | - | × | × | ABS motor relay signal (On/Off) status is displayed. |
| ACTUATOR RLY (On/Off) | - | × | × | ABS actuator relay signal (On/Off) status is displayed. |
| ABS WARN LAMP (On/Off) | - | × | × | ABS warning lamp (On/Off) status is displayed. |
| OFF LAMP (On/Off) | - | × | × | VDC OFF Lamp (On/Off) status is displayed. |
| OFF SW (On/Off) | × | × | × | VDC OFF switch (On/Off) status is displayed. |
| SLIP LAMP (On/Off) | - | × | × | SLIP indicator lamp (On/Off) status is displayed. |
| BATTERY VOLT (V) | × | × | × | Voltage (V) supplied to ABS actuator and electric unit (control unit) is displayed. |
| GEAR (1, 2, 3, 4, 5) | × | × | × | Gear position (1, 2, 3, 4, 5) judged by transmission rangeswitch signal is displayed. |
| SLCT LVR POSI (P, N, D) | × | × | × | Shift position (P, N, D) judged by transmission rangeswitch signal. |
| ENGINE SPEED (rpm) | × | × | × | Engine speed (rpm) judged by CAN communication signal is displayed. |
| YAW RATE SEN (d/s) | × | × | × | Yaw rate (d/s) detected by yaw rate sensor is displayed. |
| R POSI SIG (On/Off) | - | - | × | Reverse shift position (On/Off) judged by transmission rangeswitch signal. |
| 4WD FAIL REQ (On/Off) | - | - | × | Transfer control unit fail-safe mode (On/Off) is displayed. |
| N POSI SIG (On/Off) | - | - | × | Shift position judged by transmission range switch signal. |

A

B

C

D

E

BRC

G

H

I

J

K

L

M

N

O

P

DIAGNOSIS SYSTEM [ABS ACTUATOR AND ELECTRIC UNIT (CONTROL UNIT)]

< SYSTEM DESCRIPTION >

[VDC/TCS/ABS]

| Item (Unit) | Data monitor item selection | | | Remarks |
|--------------------------------------|-----------------------------|-----------------|------------------------|---|
| | ECU INPUT SIGNALS | MAIN SIGNALS | SELECTION FROM MENU | |
| P POSI SIG (On/Off) | - | - | × | Shift position judged by transmission range switch signal. |
| CV1 (On/Off) | - | - | × | Front side switch-over solenoid valve (cut valve) (On/Off) status is displayed. |
| CV2 (On/Off) | - | - | × | Rear side switch-over solenoid valve (cut-valve) (On/Off) status is displayed. |
| SV1 (On/Off) | - | - | × | Front side switch-over solenoid valve (suction valve) (On/Off) status is displayed. |
| SV2 (On/Off) | - | - | × | Rear side switch-over solenoid valve (suction valve) (On/Off) status is displayed. |
| 2WD/4WD (2WD/4WD) | - | - | × | It recognizes on software whether it is 2WD and whether it is in 4WD state. |
| ACCEL POS SIG (%) | × | - | × | Throttle valve open/close status judged by CAN communication signal is displayed. |
| SIDE G-SENSOR (m/s ²) | × | - | × | Transverse acceleration detected by side G-sensor is displayed. |
| STR ANGLE SIG (deg) | × | - | × | Steering angle detected by steering angle sensor is displayed. |
| BST OPER SIG (On/Off) | - | - | × | Active booster operation (On/Off) status is displayed. |
| PRESS SENSOR (bar) | × | - | × | Brake pressure detected by pressure sensor is displayed. |
| EBD SIGNAL (On/Off) | - | - | × | EBD operation (On/Off) status is displayed. |
| ABS SIGNAL (On/Off) | - | - | × | ABS operation (On/Off) status is displayed. |
| TCS SIGNAL (On/Off) | - | - | × | TCS operation (On/Off) status is displayed. |
| VDC SIGNAL (On/Off) | - | - | × | VDC operation (On/Off) status is displayed. |
| EBD FAIL SIG (On/Off) | - | - | × | EBD fail signal (On/Off) status is displayed. |
| ABS FAIL SIG (On/Off) | - | - | × | ABS fail signal (On/Off) status is displayed. |
| TCS FAIL SIG (On/Off) | - | - | × | TCS fail signal (On/Off) status is displayed. |
| VDC FAIL SIG (On/Off) | - | - | × | VDC fail signal (On/Off) status is displayed. |
| CRANKING SIG (On/Off) | - | - | × | The input state of the key SW START position signal is displayed. |
| FLUID LEV SW (On/Off) | × | - | × | Brake fluid level switch (On/Off) status is displayed. |
| PRESS SEN2 (bar) | - | - | × | Brake pressure detected by pressure sensor is displayed. |
| DELTA S SEN (mm) | - | - | × | The amount of stroke sensor movements in the active booster detected by DELTA S SEN is displayed. |
| RELEASE SW NO (On/Off) | - | - | × | Release switch signal (On/Off) status is displayed. "On" indicates that the brake pedal is depressed. "Off" indicates that the brake pedal is released. |

DIAGNOSIS SYSTEM [ABS ACTUATOR AND ELECTRIC UNIT (CONTROL UNIT)]

< SYSTEM DESCRIPTION >

[VDC/TCS/ABS]

| Item (Unit) | Data monitor item selection | | | Remarks |
|------------------------|-----------------------------|--------------|---------------------|---|
| | ECU INPUT SIGNALS | MAIN SIGNALS | SELECTION FROM MENU | |
| RELEASE SW NC (On/Off) | - | - | × | Release switch signal (On/Off) status is displayed. "Off" indicates that the brake pedal is depressed. "On" indicates that the brake pedal is released. |
| OHB FAIL (On/Off) | - | - | × | OHB fail status is displayed. |
| HBA FAIL (On/Off) | - | - | × | HBA fail status is displayed. |
| OHB SIG (On/Off) | - | - | × | OHB operation (On/Off) status is displayed. |
| HBA SIG (On/Off) | - | - | × | HBA operation (On/Off) status is displayed. |
| STP OFF RLY (On/Off) | - | - | × | Stop lamp relay signal (On/Off) status is displayed. |

×: Applicable

-: Not applicable

ACTIVE TEST

CAUTION:

- Do not perform active test while driving vehicle.
- Make sure to completely bleed air from brake system.
- The active test cannot be performed with the ABS warning lamp, VDC OFF indicator lamp, SLIP indicator lamp or brake warning lamp on.
- ABS warning lamp, VDC OFF indicator lamp, SLIP indicator lamp and brake warning lamp are on during active test.

NOTE:

- When active test is performed while depressing the pedal, the pedal depression amount will change. This is normal. (Only solenoid valve and ABS motor.)
- "TEST IS STOPPED" is displayed 10 seconds after operation start.
- After "TEST IS STOPPED" is displayed, to perform test again, touch BACK.

Test Item

SOLENOID VALVE

- When performing an active test of the ABS function, select "MAIN SIGNALS" for each test item.
- For ABS solenoid valve, touch "Up", "Keep", and "Down" on the display screen. For ABS solenoid valve (ACT), touch "Up", "ACT UP", "ACT KEEP" and confirm that solenoid valves operate as shown in the table below.

| Operation | | ABS solenoid valve | | | ABS solenoid valve (ACT) | | |
|--------------------------|---------------|--------------------|------|------|--------------------------|--------|----------|
| | | Up | Keep | Down | Up | ACT UP | ACT KEEP |
| FR RH SOL | FR RH IN SOL | Off | On | On | — | — | — |
| | FR RH OUT SOL | Off | Off | On* | — | — | — |
| FR LH SOL | FR LH IN SOL | Off | On | On | — | — | — |
| | FR LH OUT SOL | Off | Off | On* | — | — | — |
| RR RH SOL | RR RH IN SOL | Off | On | On | — | — | — |
| | RR RH OUT SOL | Off | Off | On* | — | — | — |
| RR LH SOL | RR LH IN SOL | Off | On | On | — | — | — |
| | RR LH OUT SOL | Off | Off | On* | — | — | — |
| FR RH ABS SOLENOID (ACT) | FR RH IN SOL | — | — | — | Off | Off | Off |
| | FR RH OUT SOL | — | — | — | Off | Off | Off |
| | CV1 | — | — | — | Off | On | On |
| | SV1 | — | — | — | Off | On* | Off |

DIAGNOSIS SYSTEM [ABS ACTUATOR AND ELECTRIC UNIT (CONTROL UNIT)]

< SYSTEM DESCRIPTION >

[VDC/TCS/ABS]

| Operation | | ABS solenoid valve | | | ABS solenoid valve (ACT) | | |
|--------------------------|---------------|--------------------|------|------|--------------------------|--------|----------|
| | | Up | Keep | Down | Up | ACT UP | ACT KEEP |
| FR LH ABS SOLENOID (ACT) | FR LH IN SOL | — | — | — | Off | Off | Off |
| | FR LH OUT SOL | — | — | — | Off | Off | Off |
| | CV1 | — | — | — | Off | On | On |
| | SV1 | — | — | — | Off | On* | Off |
| RR RH ABS SOLENOID (ACT) | RR RH IN SOL | — | — | — | Off | Off | Off |
| | RR RH OUT SOL | — | — | — | Off | Off | Off |
| | CV2 | — | — | — | Off | On | On |
| | SV2 | — | — | — | Off | On* | Off |
| RR LH ABS SOLENOID (ACT) | RR LH IN SOL | — | — | — | Off | Off | Off |
| | RR LH OUT SOL | — | — | — | Off | Off | Off |
| | CV2 | — | — | — | Off | On | On |
| | SV2 | — | — | — | Off | On* | Off |

*: On for 1 to 2 seconds after the touch, and then Off

ABS MOTOR

- Touch “On” and “Off” on screen. Make sure motor relay and actuator relay operates as shown in table below.

| Operation | On | Off |
|--------------|----|-----|
| MOTOR RELAY | On | Off |
| ACTUATOR RLY | On | On |

BOOSTER DRIVE

- Touch “Up” and “Down” on the screen. Check that booster drive operates as shown in table below.

CAUTION:

Perform active test subject to the conditions below.

- **Do not operate brake pedal during active test.**
- **Make sure the engine revolution is over 500 rpm.**
- **Make sure the vehicle is not moving.**

| Operation | Up | Down |
|--------------|------------|-------|
| BST OPER SIG | On | Off |
| PRESS SENSOR | 50 ± 5 bar | 0 bar |
| PRESS SEN2 | 50 ± 5 bar | 0 bar |
| STOP LAMP SW | On | Off |
| STP OFF RLY | Off | Off |

C1101, C1102, C1103, C1104 WHEEL SENSOR-1

< DTC/CIRCUIT DIAGNOSIS >

[VDC/TCS/ABS]

DTC/CIRCUIT DIAGNOSIS

C1101, C1102, C1103, C1104 WHEEL SENSOR-1

Description

INFOID:000000006147063

When the sensor rotor rotates, the magnetic field changes. It converts the magnetic field changes to current signals (rectangular wave) and transmits them to the ABS actuator and electric unit (control unit).

DTC Logic

INFOID:000000006147064

DTC DETECTION LOGIC

| DTC | Display item | Malfunction detected condition | Possible cause |
|-------|----------------|---|---|
| C1101 | RR RH SENSOR-1 | Circuit of rear RH wheel sensor is open. Or when the sensor power voltage is outside the standard. | <ul style="list-style-type: none">• Harness or connector• Wheel sensor• ABS actuator and electric unit (control unit) |
| C1102 | RR LH SENSOR-1 | Circuit of rear LH wheel sensor is open. Or when the sensor power voltage is outside the standard. | |
| C1103 | FR RH SENSOR-1 | Circuit of front RH wheel sensor is open. Or when the sensor power voltage is outside the standard. | |
| C1104 | FR LH SENSOR-1 | Circuit of front LH wheel sensor is open. Or when the sensor power voltage is outside the standard. | |

DTC CONFIRMATION PROCEDURE

1. CHECK SELF-DIAGNOSIS RESULTS

Check the self-diagnosis results.

| Self-diagnosis results |
|------------------------|
| RR RH SENSOR-1 |
| RR LH SENSOR-1 |
| FR RH SENSOR-1 |
| FR LH SENSOR-1 |

Is above displayed on the self-diagnosis display?

- YES >> Proceed to diagnosis procedure. Refer to [BRC-29, "Diagnosis Procedure"](#).
NO >> Inspection End

Diagnosis Procedure

INFOID:000000006147065

Regarding Wiring Diagram information, refer to [BRC-92, "Wiring Diagram"](#).

CAUTION:

Do not check between wheel sensor terminals.

1. CONNECTOR INSPECTION

1. Disconnect the ABS actuator and electric unit (control unit) connector and wheel sensor of malfunctioning code.
2. Check the terminals for deformation, disconnection, looseness or damage.

Is the inspection result normal?

- YES >> GO TO 2
NO >> Repair or replace as necessary.

2. CHECK WHEEL SENSOR OUTPUT SIGNAL

1. Connect ABS active wheel sensor tester (J-45741) to wheel sensor using appropriate adapter.
2. Turn on the ABS active wheel sensor tester power switch.

C1101, C1102, C1103, C1104 WHEEL SENSOR-1

< DTC/CIRCUIT DIAGNOSIS >

[VDC/TCS/ABS]

NOTE:

The green POWER indicator should illuminate. If the POWER indicator does not illuminate, replace the battery in the ABS active wheel sensor tester before proceeding.

- Spin the wheel of the vehicle by hand and observe the red SENSOR indicator on the ABS active wheel sensor tester. The red SENSOR indicator should flash on and off to indicate an output signal.

NOTE:

If the red SENSOR indicator illuminates but does not flash, reverse the polarity of the tester leads and retest.

Does the ABS active wheel sensor tester detect a signal?

- YES >> GO TO 3
- NO >> Replace the wheel sensor. Refer to [BRC-113, "Removal and Installation"](#).

3.CHECK TIRES

Check the inflation pressure, wear and size of each tire.

Is the inspection result normal?

- YES >> GO TO 4
- NO >> Adjust tire pressure or replace tire(s).

4.CHECK WHEEL BEARINGS

Check wheel bearing axial end play. Refer to [FAX-6, "On-Vehicle Inspection and Service"](#) (front) or [RAX-6, "On-Vehicle Inspection and Service"](#) (rear).

Is the inspection result normal?

- YES >> GO TO 5
- NO >> Repair or replace as necessary. Refer to [FAX-7, "Removal and Installation"](#) (front) or [RAX-7, "Removal and Installation"](#) (rear).

5.CHECK WIRING HARNESS FOR SHORT CIRCUIT

- Disconnect ABS actuator and electric unit (control unit) connector and wheel sensor connector of malfunction code.
- Check continuity between wheel sensor connector terminals and ground.

Continuity should not exist.

Is the inspection result normal?

- YES >> GO TO 6
- NO >> Repair the circuit.

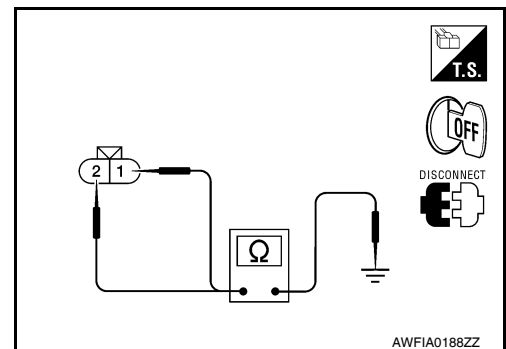

6.CHECK WIRING HARNESS FOR OPEN CIRCUIT

- Check continuity between ABS actuator and electric unit (control unit) connector and the malfunctioning wheel sensor connector.

| Wheel sensor | ABS actuator and electric unit (control unit) | | Wheel sensor | | Continuity |
|--------------|---|----------|--------------|----------|------------|
| | Connector | Terminal | Connector | Terminal | |
| Front LH | E125 | 45 | E18 | 1 | Yes |
| | | 46 | | 2 | |
| Front RH | | 34 | E117 | 1 | |
| | | 33 | | 2 | |
| Rear LH | | 37 | C11 | 2 | |
| | | 36 | | 1 | |
| Rear RH | | 42 | C10 | 2 | |
| | | 43 | | 1 | |

Is the inspection result normal?

C1101, C1102, C1103, C1104 WHEEL SENSOR-1

< DTC/CIRCUIT DIAGNOSIS >

[VDC/TCS/ABS]

- YES >> Replace the ABS actuator and electric unit (control unit). Refer to [BRC-115. "Removal and Installation"](#).
NO >> Repair the circuit.

Component Inspection

INFOID:000000006147066

1. CHECK DATA MONITOR

On "DATA MONITOR", select "FR LH SENSOR", "FR RH SENSOR", "RR LH SENSOR", and "RR RH SENSOR", and check the vehicle speed.

| Wheel sensor | Vehicle speed (DATA MONITOR) |
|--------------|--|
| FR LH SENSOR | Nearly matches the speedometer display ($\pm 10\%$ or less) |
| FR RH SENSOR | |
| RR LH SENSOR | |
| RR RH SENSOR | |

Is the inspection result normal?

- YES >> Inspection End
NO >> Go to diagnosis procedure. Refer to [BRC-29. "Diagnosis Procedure"](#).

Special Repair Requirement

INFOID:000000006147067

1. ADJUSTMENT OF STEERING ANGLE SENSOR NEUTRAL POSITION

Always perform neutral position adjustment for the steering angle sensor when replacing the ABS actuator and electric unit (control unit). Refer to [BRC-8. "ADJUSTMENT OF STEERING ANGLE SENSOR NEUTRAL POSITION : Description"](#).

>> GO TO 2

2. CALIBRATION OF DECEL G SENSOR

Always perform calibration of decel G sensor when replacing the ABS actuator and electric unit (control unit). Refer to [BRC-9. "CALIBRATION OF DECEL G SENSOR : Description"](#).

>> END

C1105, C1106, C1107, C1108 WHEEL SENSOR-2

< DTC/CIRCUIT DIAGNOSIS >

[VDC/TCS/ABS]

C1105, C1106, C1107, C1108 WHEEL SENSOR-2

Description

INFOID:000000006147068

When the sensor rotor rotates, the magnetic field changes. It converts the magnetic field changes to current signals (rectangular wave) and transmits them to the ABS actuator and electric unit (control unit).

DTC Logic

INFOID:000000006147069

DTC DETECTION LOGIC

| DTC | Display item | Malfunction detected condition | Possible cause |
|-------|----------------|--|---|
| C1105 | RR RH SENSOR-2 | When the circuit in the rear RH wheel sensor is short-circuited. Or when the distance between the wheel sensor and sensor rotor is too large and the sensor pulse cannot be recognized by the control unit. | <ul style="list-style-type: none">• Harness or connector• Wheel sensor• ABS actuator and electric unit (control unit) |
| C1106 | RR LH SENSOR-2 | When the circuit in the rear LH wheel sensor is short-circuited. Or when the distance between the wheel sensor and sensor rotor is too large and the sensor pulse cannot be recognized by the control unit. | |
| C1107 | FR RH SENSOR-2 | When the circuit in the front RH wheel sensor is short-circuited. Or when the distance between the wheel sensor and sensor rotor is too large and the sensor pulse cannot be recognized by the control unit. | |
| C1108 | FR LH SENSOR-2 | When the circuit in the front LH wheel sensor is short-circuited. Or when the distance between the wheel sensor and sensor rotor is too large and the sensor pulse cannot be recognized by the control unit. | |

DTC CONFIRMATION PROCEDURE

1. CHECK SELF-DIAGNOSIS RESULTS

Check the self-diagnosis results.

| |
|------------------------|
| Self-diagnosis results |
| RR RH SENSOR-2 |
| RR LH SENSOR-2 |
| FR RH SENSOR-2 |
| FR LH SENSOR-2 |

Is above displayed on the self-diagnosis display?

YES >> Proceed to diagnosis procedure. Refer to [BRC-32. "Diagnosis Procedure"](#).

NO >> Inspection End

Diagnosis Procedure

INFOID:000000006570210

Regarding Wiring Diagram information, refer to [BRC-92. "Wiring Diagram"](#).

CAUTION:

Do not check between wheel sensor terminals.

1. CONNECTOR INSPECTION

1. Disconnect the ABS actuator and electric unit (control unit) connector and wheel sensor of malfunctioning code.
2. Check the terminals for deformation, disconnection, looseness or damage.

Is the inspection result normal?

YES >> GO TO 2

C1105, C1106, C1107, C1108 WHEEL SENSOR-2

< DTC/CIRCUIT DIAGNOSIS >

[VDC/TCS/ABS]

NO >> Repair or replace as necessary.

2.CHECK WHEEL SENSOR OUTPUT SIGNAL

1. Connect ABS active wheel sensor tester (J-45741) to wheel sensor using appropriate adapter.
2. Turn on the ABS active wheel sensor tester power switch.

NOTE:

The green POWER indicator should illuminate. If the POWER indicator does not illuminate, replace the battery in the ABS active wheel sensor tester before proceeding.

3. Spin the wheel of the vehicle by hand and observe the red SENSOR indicator on the ABS active wheel sensor tester. The red SENSOR indicator should flash on and off to indicate an output signal.

NOTE:

If the red SENSOR indicator illuminates but does not flash, reverse the polarity of the tester leads and retest.

Does the ABS active wheel sensor tester detect a signal?

YES >> GO TO 3

NO >> Replace the wheel sensor. Refer to [BRC-113, "Removal and Installation"](#).

3.CHECK TIRES

Check the inflation pressure, wear and size of each tire.

Is the inspection result normal?

YES >> GO TO 4

NO >> Adjust tire pressure or replace tire(s).

4.CHECK WHEEL BEARINGS

Check wheel bearing axial end play. Refer to [FAX-6, "On-Vehicle Inspection and Service"](#) (front) or [RAX-6, "On-Vehicle Inspection and Service"](#) (rear).

Is the inspection result normal?

YES >> GO TO 5

NO >> Repair or replace as necessary. Refer to [FAX-7, "Removal and Installation"](#) (front) or [RAX-7, "Removal and Installation"](#) (rear).

5.CHECK WIRING HARNESS FOR SHORT CIRCUIT

1. Disconnect ABS actuator and electric unit (control unit) connector and wheel sensor connector of malfunction code.
2. Check continuity between wheel sensor connector terminals and ground.

Continuity should not exist.

Is the inspection result normal?

YES >> GO TO 6

NO >> Repair the circuit.

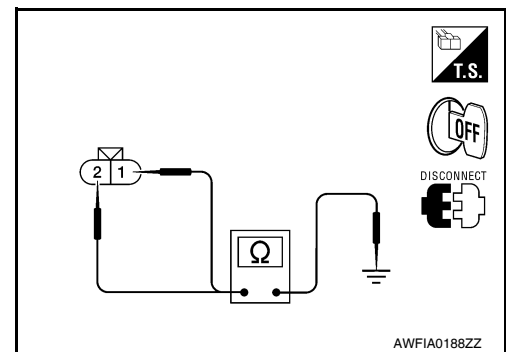

6.CHECK WIRING HARNESS FOR OPEN CIRCUIT

1. Check continuity between ABS actuator and electric unit (control unit) connector and the malfunctioning wheel sensor connector.

A
B
C
D
E
G
H
I
J
K
L
M
N
O
P

BRC

C1105, C1106, C1107, C1108 WHEEL SENSOR-2

< DTC/CIRCUIT DIAGNOSIS >

[VDC/TCS/ABS]

| Wheel sensor | ABS actuator and electric unit (control unit) | | Wheel sensor | | Continuity |
|--------------|---|----------|--------------|----------|------------|
| | Connector | Terminal | Connector | Terminal | |
| Front LH | E125 | 45 | E18 | 1 | Yes |
| | | 46 | | 2 | |
| Front RH | | 34 | E117 | 1 | |
| | | 33 | | 2 | |
| Rear LH | | 37 | C11 | 2 | |
| | | 36 | | 1 | |
| Rear RH | | 42 | C10 | 2 | |
| | | 43 | | 1 | |

Is the inspection result normal?

YES >> Replace the ABS actuator and electric unit (control unit). Refer to [BRC-115. "Removal and Installation"](#).

NO >> Repair the circuit.

Component Inspection

INFOID:000000006570211

1. CHECK DATA MONITOR

On "DATA MONITOR", select "FR LH SENSOR", "FR RH SENSOR", "RR LH SENSOR", and "RR RH SENSOR", and check the vehicle speed.

| Wheel sensor | Vehicle speed (DATA MONITOR) |
|--------------|--|
| FR LH SENSOR | Nearly matches the speedometer display ($\pm 10\%$ or less) |
| FR RH SENSOR | |
| RR LH SENSOR | |
| RR RH SENSOR | |

Is the inspection result normal?

YES >> Inspection End

NO >> Go to diagnosis procedure. Refer to [BRC-32. "Diagnosis Procedure"](#).

Special Repair Requirement

INFOID:000000006570212

1. ADJUSTMENT OF STEERING ANGLE SENSOR NEUTRAL POSITION

Always perform neutral position adjustment for the steering angle sensor when replacing the ABS actuator and electric unit (control unit). Refer to [BRC-8. "ADJUSTMENT OF STEERING ANGLE SENSOR NEUTRAL POSITION : Description"](#).

>> GO TO 2

2. CALIBRATION OF DECEL G SENSOR

Always perform calibration of decel G sensor when replacing the ABS actuator and electric unit (control unit). Refer to [BRC-9. "CALIBRATION OF DECEL G SENSOR : Description"](#).

>> END

C1109 POWER AND GROUND SYSTEM

< DTC/CIRCUIT DIAGNOSIS >

[VDC/TCS/ABS]

C1109 POWER AND GROUND SYSTEM

Description

INFOID:000000006147073

Supplies electric power to the ABS actuator and electric unit (control unit).

DTC Logic

INFOID:000000006147074

DTC DETECTION LOGIC

| DTC | Display item | Malfunction detected condition | Possible cause |
|-------|----------------------------|---|---|
| C1109 | BATTERY VOLTAGE [ABNORMAL] | When the ABS actuator and electric unit (control unit) power supply voltage is lower than normal. | <ul style="list-style-type: none"> • Harness or connector • ABS actuator and electric unit (control unit) |

DTC CONFIRMATION PROCEDURE

1. CHECK SELF-DIAGNOSIS RESULTS

Check the self-diagnosis results.

| Self-diagnosis results |
|----------------------------|
| BATTERY VOLTAGE [ABNORMAL] |

Is above displayed on the self-diagnosis display?

- YES >> Proceed to diagnosis procedure. Refer to [BRC-35, "Diagnosis Procedure"](#).
 NO >> Inspection End

Diagnosis Procedure

INFOID:000000006147075

Regarding Wiring Diagram information, refer to [BRC-92, "Wiring Diagram"](#).

1. CONNECTOR INSPECTION

1. Turn ignition switch OFF.
2. Disconnect ABS actuator and electric unit (control unit) connector.
3. Check terminal for deformation, disconnection, looseness, and so on. If any malfunction is found, repair or replace terminal.
4. Reconnect connectors and then perform the self-diagnosis. Refer to [BRC-24, "CONSULT-III Function \(ABS\)"](#).

Is any item indicated on the self-diagnosis display?

- YES >> GO TO 2
 NO >> Poor connection of connector terminal. Repair or replace connector.

2. CHECK ABS ACTUATOR AND ELECTRIC UNIT (CONTROL UNIT) POWER SUPPLY CIRCUIT AND GROUND CIRCUIT

1. Turn ignition switch OFF.
2. Disconnect ABS actuator and electric unit (control unit) connector.
3. Turn ignition switch ON or OFF and check voltage between ABS actuator and electric unit (control unit) connector E125 terminal 4 and ground.

| ABS actuator and electric unit (control unit) | | — | Condition | Voltage |
|---|----------|--------|----------------------|-----------------|
| Connector | Terminal | | | |
| E125 | 4 | Ground | Ignition switch: ON | Battery voltage |
| | | | Ignition switch: OFF | Approx. 0V |

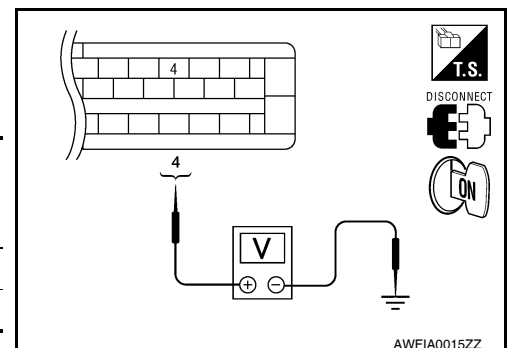

C1109 POWER AND GROUND SYSTEM

< DTC/CIRCUIT DIAGNOSIS >

[VDC/TCS/ABS]

4. Turn ignition switch OFF.
5. Check continuity between ABS actuator and electric unit (control unit) connector E125 terminals 16, 47 and ground.

| ABS actuator and electric unit (control unit) | | — | Continuity |
|---|----------|--------|------------|
| Connector | Terminal | | |
| E125 | 16, 47 | Ground | Yes |

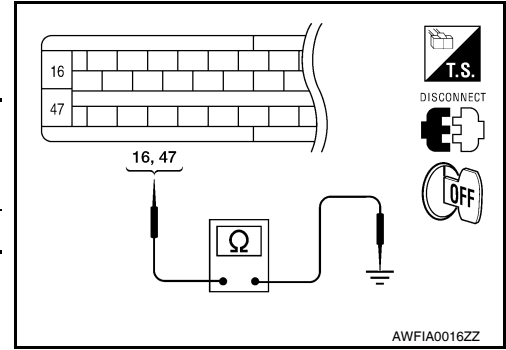

Is the inspection result normal?

- YES >> Check battery for terminal looseness, low voltage, etc. If any malfunction is found, repair malfunctioning parts.
- NO >> Repair or replace malfunctioning components.

Special Repair Requirement

INFOID:000000006570216

1. ADJUSTMENT OF STEERING ANGLE SENSOR NEUTRAL POSITION

Always perform neutral position adjustment for the steering angle sensor when replacing the ABS actuator and electric unit (control unit). Refer to [BRC-8. "ADJUSTMENT OF STEERING ANGLE SENSOR NEUTRAL POSITION : Description"](#).

>> GO TO 2

2. CALIBRATION OF DECEL G SENSOR

Always perform calibration of decel G sensor when replacing the ABS actuator and electric unit (control unit). Refer to [BRC-9. "CALIBRATION OF DECEL G SENSOR : Description"](#).

>> END

C1110, C1170 ABS ACTUATOR AND ELECTRIC UNIT (CONTROL UNIT)

< DTC/CIRCUIT DIAGNOSIS >

[VDC/TCS/ABS]

C1110, C1170 ABS ACTUATOR AND ELECTRIC UNIT (CONTROL UNIT)

DTC Logic

INFOID:000000006147077

DTC DETECTION LOGIC

| DTC | Display item | Malfunction detected condition | Possible cause |
|-------|--------------------|---|---|
| C1110 | CONTROLLER FAILURE | When there is an internal malfunction in the ABS actuator and electric unit (control unit). | • ABS actuator and electric unit (control unit) |
| C1170 | VARIANT CODING | In a case where VARIANT CODING is different. | |

DTC CONFIRMATION PROCEDURE

1. CHECK SELF-DIAGNOSIS RESULTS

Check the self-diagnosis results.

| |
|------------------------|
| Self-diagnosis results |
| CONTROLLER FAILURE |
| VARIANT CODING |

Is above displayed on the self-diagnosis display?

- YES >> Proceed to diagnosis procedure. Refer to [BRC-37. "Diagnosis Procedure"](#).
- NO >> Inspection End

Diagnosis Procedure

INFOID:000000006147078

1. REPLACE ABS ACTUATOR AND ELECTRIC UNIT (CONTROL UNIT)

- >> Replace ABS actuator and electric unit (control unit). Refer to [BRC-115. "Removal and Installation"](#).

Special Repair Requirement

INFOID:000000006570217

1. ADJUSTMENT OF STEERING ANGLE SENSOR NEUTRAL POSITION

Always perform neutral position adjustment for the steering angle sensor when replacing the ABS actuator and electric unit (control unit). Refer to [BRC-8. "ADJUSTMENT OF STEERING ANGLE SENSOR NEUTRAL POSITION : Description"](#).

>> GO TO 2

2. CALIBRATION OF DECEL G SENSOR

Always perform calibration of decel G sensor when replacing the ABS actuator and electric unit (control unit). Refer to [BRC-9. "CALIBRATION OF DECEL G SENSOR : Description"](#).

>> END

C1111 ABS MOTOR, MOTOR RELAY SYSTEM

< DTC/CIRCUIT DIAGNOSIS >

[VDC/TCS/ABS]

C1111 ABS MOTOR, MOTOR RELAY SYSTEM

Description

INFOID:000000006147080

PUMP

The pump returns the brake fluid stored in the reservoir to the master cylinder by reducing the pressure.

MOTOR

The motor drives the pump according to the signals transmitted by the ABS actuator and electric unit (control unit).

DTC Logic

INFOID:000000006147081

DTC DETECTION LOGIC

| DTC | Display item | Malfunction detected condition | Possible cause |
|-------|--------------|--|--|
| C1111 | PUMP MOTOR | During the actuator motor operating with ON, when the actuator motor turns OFF, or when the control line for actuator motor relay is open. | <ul style="list-style-type: none">• Harness or connector• ABS actuator and electric unit (control unit) |
| | | During the actuator motor operating with OFF, when the actuator motor turns ON, or when the control line for relay is shorted to ground. | |

DTC CONFIRMATION PROCEDURE

1. CHECK SELF-DIAGNOSIS RESULTS

Check the self-diagnosis results.

| |
|------------------------|
| Self-diagnosis results |
| PUMP MOTOR |

Is above displayed on the self-diagnosis display?

YES >> Proceed to diagnosis procedure. Refer to [BRC-38, "Diagnosis Procedure"](#).

NO >> Inspection End

Diagnosis Procedure

INFOID:000000006147082

Regarding Wiring Diagram information, refer to [BRC-92, "Wiring Diagram"](#).

1. CONNECTOR INSPECTION

1. Turn ignition switch OFF.
2. Disconnect ABS actuator and electric unit (control unit) connector.
3. Check terminal for deformation, disconnect, looseness, and so on. If any malfunction is found, repair or replace terminal.
4. Reconnect connectors and then perform the self-diagnosis. Refer to [BRC-24, "CONSULT-III Function \(ABS\)"](#).

Is any item indicated on the self-diagnosis display?

YES >> GO TO 2

NO >> Poor connection of connector terminal. Repair or replace connector.

2. CHECK ABS MOTOR AND MOTOR RELAY POWER SUPPLY CIRCUIT

C1111 ABS MOTOR, MOTOR RELAY SYSTEM

[VDC/TCS/ABS]

< DTC/CIRCUIT DIAGNOSIS >

1. Turn ignition switch OFF.
2. Disconnect ABS actuator and electric unit (control unit) connector.
3. Check voltage between the ABS actuator and electric unit (control unit) connector E125 terminal 1 and ground.

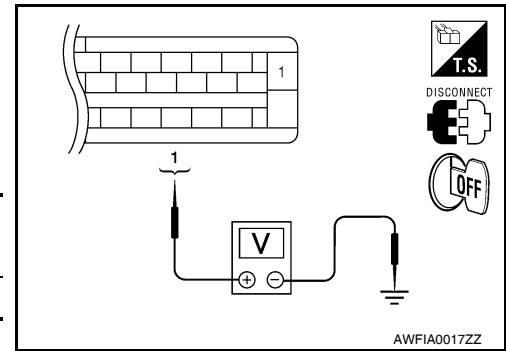

| ABS actuator and electric unit (control unit) | | — | Voltage |
|---|----------|--------|-----------------|
| Connector | Terminal | | |
| E125 | 1 | Ground | Battery voltage |

Is the inspection result normal?

- YES >> GO TO 3
 NO >> Repair or replace malfunctioning components.

3.CHECK ABS ACTUATOR AND ELECTRIC UNIT (CONTROL UNIT) GROUND CIRCUIT

Check continuity between ABS actuator and electric unit (control unit) connector E125 terminals 16, 47 and ground.

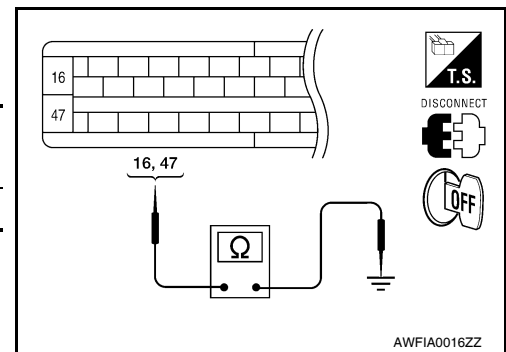

| ABS actuator and electric unit (control unit) | | — | Continuity |
|---|----------|--------|------------|
| Connector | Terminal | | |
| E125 | 16, 47 | Ground | Yes |

Is the inspection result normal?

- YES >> Replace ABS actuator and electric unit (control unit).
 Refer to [BRC-115, "Removal and Installation"](#).
 NO >> Repair or replace malfunctioning components.

Component Inspection

INFOID:000000006147083

1.CHECK ACTIVE TEST

1. On "ACTIVE TEST", select "ABS MOTOR".
2. Touch "On" and "Off" on screen. Make sure motor relay and actuator relay operates as shown in table below.

| Operation | On | Off |
|--------------|----|-----|
| MOTOR RELAY | On | Off |
| ACTUATOR RLY | On | On |

Is the inspection result normal?

- YES >> Inspection End
 NO >> Go to diagnosis procedure. Refer to [BRC-38, "Diagnosis Procedure"](#).

Special Repair Requirement

INFOID:000000006570218

1.ADJUSTMENT OF STEERING ANGLE SENSOR NEUTRAL POSITION

Always perform neutral position adjustment for the steering angle sensor when replacing the ABS actuator and electric unit (control unit). Refer to [BRC-8, "ADJUSTMENT OF STEERING ANGLE SENSOR NEUTRAL POSITION : Description"](#).

>> GO TO 2

2.CALIBRATION OF DECEL G SENSOR

Always perform calibration of decel G sensor when replacing the ABS actuator and electric unit (control unit). Refer to [BRC-9, "CALIBRATION OF DECEL G SENSOR : Description"](#).

>> END

C1113, C1145, C1146 YAW RATE/SIDE/DECEL G SENSOR

< DTC/CIRCUIT DIAGNOSIS >

[VDC/TCS/ABS]

C1113, C1145, C1146 YAW RATE/SIDE/DECEL G SENSOR

Description

INFOID:000000006147085

The yaw rate/side/decel G sensor detects the yaw rate/side/decel G affecting the vehicle, and transmits the data to the ABS actuator and electric unit (control unit) as an analog voltage signal.

DTC Logic

INFOID:000000006147086

DTC DETECTION LOGIC

| DTC | Display item | Malfunction detected condition | Possible cause |
|-------|--------------------|--|---|
| C1113 | G-SENSOR | Longitudinal G-sensor is malfunctioning, or signal line of longitudinal G-sensor is open or shorted. | • Harness or connector • ABS actuator and electric unit (control unit) • Yaw rate/side/decel G sensor |
| C1145 | YAW RATE SENSOR | Yaw rate sensor is malfunctioning, or the yaw rate sensor signal line is open or shorted. | |
| C1146 | SIDE G-SEN CIRCUIT | Side G sensor is malfunctioning, or circuit of side G sensor is open or shorted. | |

DTC CONFIRMATION PROCEDURE

1. CHECK SELF-DIAGNOSIS RESULTS

Check the self-diagnosis results.

| |
|------------------------|
| Self-diagnosis results |
| G-SENSOR |
| YAW RATE SENSOR |
| SIDE G-SEN CIRCUIT |

Is above displayed on the self-diagnosis display?

- YES >> Proceed to diagnosis procedure. Refer to [BRC-40. "Diagnosis Procedure"](#).
NO >> Inspection End

Diagnosis Procedure

INFOID:000000006147087

Regarding Wiring Diagram information, refer to [BRC-92. "Wiring Diagram"](#).

CAUTION:

- Sudden turns (such as spin turns, acceleration turns), drifting, etc. when VDC function is OFF may cause the yaw rate/side/decel G sensor system to indicate a malfunction. This is not a malfunction if normal operation can be resumed after restarting the engine.
- If vehicle is on turn table at entrance to parking garage, or on other moving surface, VDC OFF indicator lamp may illuminate and CONSULT-III self-diagnosis may indicate yaw rate sensor system malfunction. However, in this case there is no malfunction in yaw rate sensor system. Take vehicle off of turn table or other moving surface, and start engine. Results will return to normal.

1. CONNECTOR INSPECTION

1. Disconnect the ABS actuator and electric unit (control unit) connector and yaw rate/side/decel G sensor connector.
2. Check the terminals for deformation, disconnection, looseness or damage.

Is the inspection result normal?

- YES >> GO TO 2
NO >> Repair or replace as necessary.

2. YAW RATE/SIDE/DECEL G SENSOR HARNESS INSPECTION

Check continuity between the ABS actuator and electric unit (control unit) connector E125 (A) and the yaw rate/side/decel G sensor connector M108 (B).

C1113, C1145, C1146 YAW RATE/SIDE/DECEL G SENSOR

< DTC/CIRCUIT DIAGNOSIS >

[VDC/TCS/ABS]

| ABS actuator and electric unit (control unit) | | Yaw rate/side/decel G sensor | | Continuity |
|---|----------|------------------------------|----------|------------|
| Connector | Terminal | Connector | Terminal | |
| E125 (A) | 6 | M108 (B) | 4 | Yes |
| | 24 | | 1 | |
| | 25 | | 2 | |
| | 29 | | 3 | |

Is the inspection result normal?

YES >> GO TO 3

NO >> Repair or replace as necessary.

3. YAW RATE/SIDE/DECEL G SENSOR INSPECTION

1. Connect the yaw rate/side/decel G sensor connector and ABS actuator and electric unit (control unit) connector.
2. Perform the yaw rate/side/decel G sensor component inspection. Refer to [BRC-41, "Component Inspection"](#).

Is the inspection result normal?

YES >> Replace the ABS actuator and electric unit (control unit). Refer to [BRC-115, "Removal and Installation"](#).

NO >> Replace the yaw rate/side/decel G sensor. Refer to [BRC-118, "Removal and Installation"](#).

Component Inspection

INFOID:000000006147088

1. CHECK DATA MONITOR

Select "YAW RATE SEN", "SIDE G-SENSOR", "DECEL G-SEN" in "DATA MONITOR" and check yaw rate/side/decel G sensor signal.

| Vehicle condition | YAW RATE SEN (DATA MONITOR) | SIDE G-SENSOR (DATA MONITOR) | DECEL G-SEN (DATA MONITOR) |
|-------------------|-----------------------------|------------------------------|----------------------------|
| Stopped | -4 to +4 deg/s | -1.1 to +1.1 m/s | -0.11 G to +0.11 G |
| Turning right | Negative value | Negative value | - |
| Turning left | Positive value | Positive value | - |
| Speed up | - | - | Negative value |
| Speed down | - | - | Positive value |

Is the inspection result normal?

YES >> Inspection End

NO >> Go to diagnosis procedure. Refer to [BRC-40, "Diagnosis Procedure"](#).

Special Repair Requirement

INFOID:000000006570219

1. ADJUSTMENT OF STEERING ANGLE SENSOR NEUTRAL POSITION

Always perform neutral position adjustment for the steering angle sensor when replacing the ABS actuator and electric unit (control unit). Refer to [BRC-8, "ADJUSTMENT OF STEERING ANGLE SENSOR NEUTRAL POSITION : Description"](#).

>> GO TO 2

2. CALIBRATION OF DECEL G SENSOR

Always perform calibration of decel G sensor when replacing the ABS actuator and electric unit (control unit). Refer to [BRC-9, "CALIBRATION OF DECEL G SENSOR : Description"](#).

>> END

C1115 WHEEL SENSOR

< DTC/CIRCUIT DIAGNOSIS >

[VDC/TCS/ABS]

C1115 WHEEL SENSOR

Description

INFOID:000000006147090

When the sensor rotor rotates, the magnetic field changes. It converts the magnetic field changes to current signals (rectangular wave) and transmits them to the ABS actuator and electric unit (control unit).

DTC Logic

INFOID:000000006147091

DTC DETECTION LOGIC

| DTC | Display item | Malfunction detected condition | Possible cause |
|-------|---------------------------------|---|---|
| C1115 | ABS SENSOR [ABNORMAL SIGNAL] | When wheel sensor input signal is malfunctioning. | <ul style="list-style-type: none">• Harness or connector• Wheel sensor• ABS actuator and electric unit (control unit) |

DTC CONFIRMATION PROCEDURE

1. CHECK SELF-DIAGNOSIS RESULTS

Check the self-diagnosis results.

| |
|------------------------------|
| Self-diagnosis results |
| ABS SENSOR [ABNORMAL SIGNAL] |

Is above displayed on the self-diagnosis display?

- YES >> Proceed to diagnosis procedure. Refer to [BRC-42. "Diagnosis Procedure"](#).
NO >> Inspection End

Diagnosis Procedure

INFOID:000000006570213

Regarding Wiring Diagram information, refer to [BRC-92. "Wiring Diagram"](#).

CAUTION:

Do not check between wheel sensor terminals.

1. CONNECTOR INSPECTION

1. Disconnect the ABS actuator and electric unit (control unit) connector and wheel sensor of malfunctioning code.
2. Check the terminals for deformation, disconnection, looseness or damage.

Is the inspection result normal?

- YES >> GO TO 2
NO >> Repair or replace as necessary.

2. CHECK WHEEL SENSOR OUTPUT SIGNAL

1. Connect ABS active wheel sensor tester (J-45741) to wheel sensor using appropriate adapter.
2. Turn on the ABS active wheel sensor tester power switch.

NOTE:

The green POWER indicator should illuminate. If the POWER indicator does not illuminate, replace the battery in the ABS active wheel sensor tester before proceeding.

3. Spin the wheel of the vehicle by hand and observe the red SENSOR indicator on the ABS active wheel sensor tester. The red SENSOR indicator should flash on and off to indicate an output signal.

NOTE:

If the red SENSOR indicator illuminates but does not flash, reverse the polarity of the tester leads and retest.

Does the ABS active wheel sensor tester detect a signal?

- YES >> GO TO 3
NO >> Replace the wheel sensor. Refer to [BRC-113. "Removal and Installation"](#).

C1115 WHEEL SENSOR

[VDC/TCS/ABS]

< DTC/CIRCUIT DIAGNOSIS >

3.CHECK TIRES

Check the inflation pressure, wear and size of each tire.

Is the inspection result normal?

YES >> GO TO 4

NO >> Adjust tire pressure or replace tire(s).

4.CHECK WHEEL BEARINGS

Check wheel bearing axial end play. Refer to [FAX-6, "On-Vehicle Inspection and Service"](#) (front) or [RAX-6, "On-Vehicle Inspection and Service"](#) (rear).

Is the inspection result normal?

YES >> GO TO 5

NO >> Repair or replace as necessary. Refer to [FAX-7, "Removal and Installation"](#) (front) or [RAX-7, "Removal and Installation"](#) (rear).

5.CHECK WIRING HARNESS FOR SHORT CIRCUIT

1. Disconnect ABS actuator and electric unit (control unit) connector and wheel sensor connector of malfunction code.
2. Check continuity between wheel sensor connector terminals and ground.

Continuity should not exist.

Is the inspection result normal?

YES >> GO TO 6

NO >> Repair the circuit.

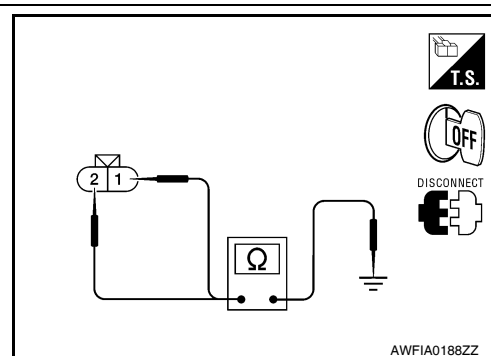

6.CHECK WIRING HARNESS FOR OPEN CIRCUIT

1. Check continuity between ABS actuator and electric unit (control unit) connector and the malfunctioning wheel sensor connector.

| Wheel sensor | ABS actuator and electric unit (control unit) | | Wheel sensor | | Continuity |
|--------------|---|----------|--------------|----------|------------|
| | Connector | Terminal | Connector | Terminal | |
| Front LH | E125 | 45 | E18 | 1 | Yes |
| | | 46 | | 2 | |
| Front RH | | 34 | E117 | 1 | |
| | | 33 | | 2 | |
| Rear LH | | 37 | C11 | 2 | |
| | | 36 | | 1 | |
| Rear RH | | 42 | C10 | 2 | |
| | | 43 | | 1 | |

Is the inspection result normal?

YES >> Replace the ABS actuator and electric unit (control unit). Refer to [BRC-115, "Removal and Installation"](#).

NO >> Repair the circuit.

Component Inspection

INFOID:000000006570214

1.CHECK DATA MONITOR

On "DATA MONITOR", select "FR LH SENSOR", "FR RH SENSOR", "RR LH SENSOR", and "RR RH SENSOR", and check the vehicle speed.

C1115 WHEEL SENSOR

< DTC/CIRCUIT DIAGNOSIS >

[VDC/TCS/ABS]

| Wheel sensor | Vehicle speed (DATA MONITOR) |
|--------------|--|
| FR LH SENSOR | Nearly matches the speedometer display ($\pm 10\%$ or less) |
| FR RH SENSOR | |
| RR LH SENSOR | |
| RR RH SENSOR | |

Is the inspection result normal?

YES >> Inspection End

NO >> Go to diagnosis procedure. Refer to [BRC-42, "Diagnosis Procedure"](#).

Special Repair Requirement

INFOID:000000006570215

1. ADJUSTMENT OF STEERING ANGLE SENSOR NEUTRAL POSITION

Always perform neutral position adjustment for the steering angle sensor when replacing the ABS actuator and electric unit (control unit). Refer to [BRC-8, "ADJUSTMENT OF STEERING ANGLE SENSOR NEUTRAL POSITION : Description"](#).

>> GO TO 2

2. CALIBRATION OF DECEL G SENSOR

Always perform calibration of decel G sensor when replacing the ABS actuator and electric unit (control unit). Refer to [BRC-9, "CALIBRATION OF DECEL G SENSOR : Description"](#).

>> END

C1116 STOP LAMP SWITCH

< DTC/CIRCUIT DIAGNOSIS >

[VDC/TCS/ABS]

C1116 STOP LAMP SWITCH

Description

INFOID:000000006147095

The stop lamp switch transmits the stop lamp switch signal (ON/OFF) to the ABS actuator and electric unit (control unit).

DTC Logic

INFOID:000000006147096

DTC DETECTION LOGIC

| DTC | Display item | Malfunction detected condition | Possible cause |
|-------|--------------|--|---|
| C1116 | STOP LAMP SW | When stop lamp switch circuit is open. | <ul style="list-style-type: none">• Harness or connector• Stop lamp switch• ABS actuator and electric unit (control unit) |

DTC CONFIRMATION PROCEDURE

1. CHECK SELF-DIAGNOSIS RESULTS

Check the self-diagnosis results.

| Self-diagnosis results |
|------------------------|
| STOP LAMP SW |

Is above displayed on the self-diagnosis display?

- YES >> Proceed to diagnosis procedure. Refer to [BRC-45, "Diagnosis Procedure"](#).
NO >> Inspection End

Diagnosis Procedure

INFOID:000000006147097

Regarding Wiring Diagram information, refer to [BRC-92, "Wiring Diagram"](#).

1. CONNECTOR INSPECTION

1. Disconnect the ABS actuator and electric unit (control unit) connector and stop lamp switch connector.
2. Check the terminals for deformation, disconnection, looseness or damage.

Is the inspection result normal?

- YES >> GO TO 2
NO >> Repair or replace as necessary.

2. STOP LAMP SWITCH INSPECTION

1. Connect the stop lamp switch connector.
2. Check the voltage between the ABS actuator and electric unit (control unit) connector E125 terminal 41 and body ground.

Brake pedal depressed : Battery voltage (approx. 12V)

Brake pedal released : Approx. 0V

Is the inspection result normal?

- YES >> Perform self-diagnosis again. If the same results appear, replace ABS actuator and electric unit (control unit). Refer to [BRC-115, "Removal and Installation"](#).
NO >> GO TO 3

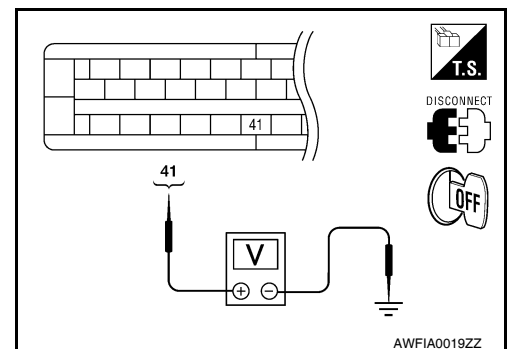

3. STOP LAMP RELAY CIRCUIT INSPECTION

C1116 STOP LAMP SWITCH

[VDC/TCS/ABS]

< DTC/CIRCUIT DIAGNOSIS >

1. Disconnect the stop lamp relay connector.
2. Check the continuity between the ABS actuator and electric unit (control unit) connector E125 (B) terminal 41 and stop lamp relay connector E12 (A) terminal 4.

Continuity should exist.

Is the inspection result normal?

- YES >> Refer to [EXL-4, "Work Flow"](#).
NO >> Repair or replace malfunctioning components.

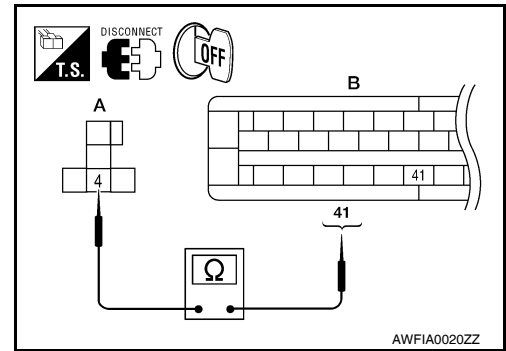

INFOID:000000006570220

Special Repair Requirement

1. ADJUSTMENT OF STEERING ANGLE SENSOR NEUTRAL POSITION

Always perform neutral position adjustment for the steering angle sensor when replacing the ABS actuator and electric unit (control unit). Refer to [BRC-8, "ADJUSTMENT OF STEERING ANGLE SENSOR NEUTRAL POSITION : Description"](#).

>> GO TO 2

2. CALIBRATION OF DECEL G SENSOR

Always perform calibration of decel G sensor when replacing the ABS actuator and electric unit (control unit). Refer to [BRC-9, "CALIBRATION OF DECEL G SENSOR : Description"](#).

>> END

C1120, C1122, C1124, C1126 IN ABS SOL

< DTC/CIRCUIT DIAGNOSIS >

[VDC/TCS/ABS]

C1120, C1122, C1124, C1126 IN ABS SOL

Description

INFOID:000000006147099

The solenoid valve increases, holds or decreases the fluid pressure of each brake caliper according to the signals transmitted by the ABS actuator and electric unit (control unit).

DTC Logic

INFOID:000000006147100

DTC DETECTION LOGIC

| DTC | Display item | Malfunction detected condition | Possible cause |
|-------|------------------|---|---|
| C1120 | FR LH IN ABS SOL | When the control unit detects a malfunction in the front LH inlet solenoid circuit. | • ABS actuator and electric unit (control unit) |
| C1122 | FR RH IN ABS SOL | When the control unit detects a malfunction in the front RH inlet solenoid circuit. | |
| C1124 | RR LH IN ABS SOL | When the control unit detects a malfunction in the rear LH inlet solenoid circuit. | |
| C1126 | RR RH IN ABS SOL | When the control unit detects a malfunction in the rear RH inlet solenoid circuit. | |

DTC CONFIRMATION PROCEDURE

1.CHECK SELF-DIAGNOSIS RESULTS

Check the self-diagnosis results.

| Self-diagnosis results |
|------------------------|
| FR LH IN ABS SOL |
| FR RH IN ABS SOL |
| RR LH IN ABS SOL |
| RR RH IN ABS SOL |

Is above displayed on the self-diagnosis display?

- YES >> Proceed to diagnosis procedure. Refer to [BRC-47. "Diagnosis Procedure"](#).
NO >> Inspection End

Diagnosis Procedure

INFOID:000000006147101

Regarding Wiring Diagram information, refer to [BRC-92. "Wiring Diagram"](#).

1.CONNECTOR INSPECTION

1. Turn ignition switch OFF.
2. Disconnect ABS actuator and electric unit (control unit) connector.
3. Check terminal for deformation, disconnection, looseness, and so on. If any malfunction is found, repair or replace terminal.
4. Reconnect connectors and then perform the self-diagnosis. Refer to [BRC-24. "CONSULT-III Function \(ABS\)"](#).

Is any item indicated on the self-diagnosis display?

- YES >> GO TO 2
NO >> Poor connection of connector terminal. Repair or replace connector.

2.CHECK SOLENOID, VDC SWITCH-OVER VALVE AND ACTUATOR RELAY POWER SUPPLY CIRCUIT

C1120, C1122, C1124, C1126 IN ABS SOL

[VDC/TCS/ABS]

< DTC/CIRCUIT DIAGNOSIS >

1. Turn ignition switch OFF.
2. Disconnect ABS actuator and electric unit (control unit) connector.
3. Check voltage between ABS actuator and electric unit (control unit) connector E125 terminal 32 and ground.

| ABS actuator and electric unit (control unit) | | — | Voltage |
|---|----------|--------|-----------------|
| Connector | Terminal | | |
| E125 | 32 | Ground | Battery voltage |

Is the inspection result normal?

- YES >> GO TO 3
 NO >> Repair or replace malfunctioning components.

3.CHECK SOLENOID, VDC SWITCH-OVER VALVE AND ACUATOR RELAY GROUND CIRCUIT

Check continuity between ABS actuator and electric unit (control unit) connector E125 terminals 16, 47 and ground.

| ABS actuator and electric unit (control unit) | | — | Continuity |
|---|----------|--------|------------|
| Connector | Terminal | | |
| E125 | 16, 47 | Ground | Yes |

Is the inspection result normal?

- YES >> Replace ABS actuator and electric unit (control unit).
 Refer to [BRC-115, "Removal and Installation"](#).
 NO >> Repair or replace malfunctioning components.

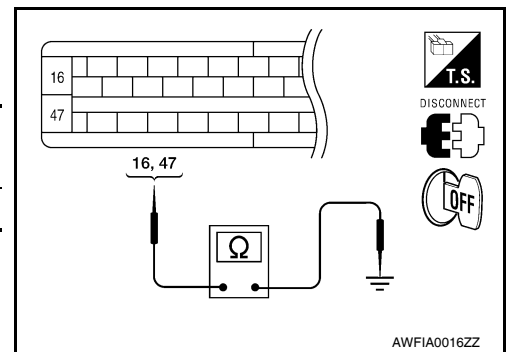
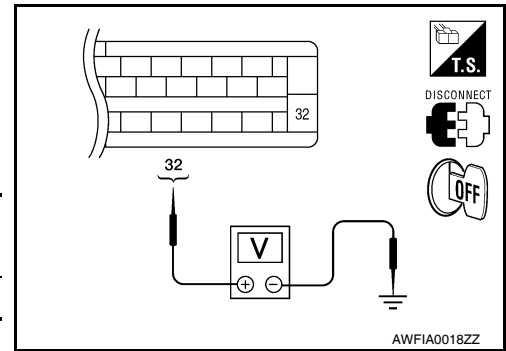

Component Inspection

INFOID:000000006147102

1.CHECK ACTIVE TEST

1. Select each test menu item on "ACTIVE TEST".
2. On the display, touch "Up", "Keep", and "Down", and check that the system operates as shown in the table below.

| Operation | | ABS solenoid valve | | |
|-----------|---------------|--------------------|------|------|
| | | Up | Keep | Down |
| FR RH SOL | FR RH IN SOL | Off | On | On |
| | FR RH OUT SOL | Off | Off | On* |
| FR LH SOL | FR LH IN SOL | Off | On | On |
| | FR LH OUT SOL | Off | Off | On* |
| RR RH SOL | RR RH IN SOL | Off | On | On |
| | RR RH OUT SOL | Off | Off | On* |
| RR LH SOL | RR LH IN SOL | Off | On | On |
| | RR LH OUT SOL | Off | Off | On* |

*: On for 1 to 2 seconds after the touch, and then Off

Is the inspection result normal?

- YES >> Inspection End
 NO >> Go to diagnosis procedure. Refer to [BRC-47, "Diagnosis Procedure"](#).

Special Repair Requirement

INFOID:000000006570223

1.AJUSTMENT OF STEERING ANGLE SENSOR NEUTRAL POSITION

Always perform neutral position adjustment for the steering angle sensor when replacing the ABS actuator and electric unit (control unit). Refer to [BRC-8, "ADJUSTMENT OF STEERING ANGLE SENSOR NEUTRAL POSITION : Description"](#).

>> GO TO 2

2.CALIBRATION OF DECEL G SENSOR

Always perform calibration of decel G sensor when replacing the ABS actuator and electric unit (control unit).
Refer to [BRC-9. "CALIBRATION OF DECEL G SENSOR : Description"](#).

>> END

A
B
C
D
E
G
H
I
J
K
L
M
N
O
P

BRC

C1121, C1123, C1125, C1127 OUT ABS SOL

< DTC/CIRCUIT DIAGNOSIS >

[VDC/TCS/ABS]

C1121, C1123, C1125, C1127 OUT ABS SOL

Description

INFOID:000000006147104

The solenoid valve increases, holds or decreases the fluid pressure of each brake caliper according to the signals transmitted by the ABS actuator and electric unit (control unit).

DTC Logic

INFOID:000000006147105

DTC DETECTION LOGIC

| DTC | Display item | Malfunction detected condition | Possible cause |
|-------|-------------------|--|---|
| C1121 | FR LH OUT ABS SOL | When the control unit detects a malfunction in the front LH outlet solenoid circuit. | • ABS actuator and electric unit (control unit) |
| C1123 | FR RH OUT ABS SOL | When the control unit detects a malfunction in the front RH outlet solenoid circuit. | |
| C1125 | RR LH OUT ABS SOL | When the control unit detects a malfunction in the rear LH outlet solenoid circuit. | |
| C1127 | RR RH OUT ABS SOL | When the control unit detects a malfunction in the rear RH outlet solenoid circuit. | |

DTC CONFIRMATION PROCEDURE

1. CHECK SELF-DIAGNOSIS RESULTS

Check the self-diagnosis results.

| Self-diagnosis results |
|------------------------|
| FR LH OUT ABS SOL |
| FR RH OUT ABS SOL |
| RR LH OUT ABS SOL |
| RR RH OUT ABS SOL |

Is above displayed on the self-diagnosis display?

- YES >> Proceed to diagnosis procedure. Refer to [BRC-50. "Diagnosis Procedure"](#).
NO >> Inspection End

Diagnosis Procedure

INFOID:000000006570221

Regarding Wiring Diagram information, refer to [BRC-92. "Wiring Diagram"](#).

1. CONNECTOR INSPECTION

1. Turn ignition switch OFF.
2. Disconnect ABS actuator and electric unit (control unit) connector.
3. Check terminal for deformation, disconnection, looseness, and so on. If any malfunction is found, repair or replace terminal.
4. Reconnect connectors and then perform the self-diagnosis. Refer to [BRC-24. "CONSULT-III Function \(ABS\)"](#).

Is any item indicated on the self-diagnosis display?

- YES >> GO TO 2
NO >> Poor connection of connector terminal. Repair or replace connector.

2. CHECK SOLENOID, VDC SWITCH-OVER VALVE AND ACTUATOR RELAY POWER SUPPLY CIRCUIT

C1121, C1123, C1125, C1127 OUT ABS SOL

[VDC/TCS/ABS]

< DTC/CIRCUIT DIAGNOSIS >

1. Turn ignition switch OFF.
2. Disconnect ABS actuator and electric unit (control unit) connector.
3. Check voltage between ABS actuator and electric unit (control unit) connector E125 terminal 32 and ground.

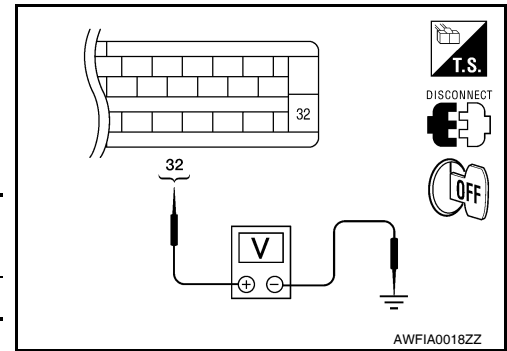

| ABS actuator and electric unit (control unit) | | — | Voltage |
|---|----------|--------|-----------------|
| Connector | Terminal | | |
| E125 | 32 | Ground | Battery voltage |

Is the inspection result normal?

- YES >> GO TO 3
 NO >> Repair or replace malfunctioning components.

3.CHECK SOLENOID, VDC SWITCH-OVER VALVE AND ACUATOR RELAY GROUND CIRCUIT

Check continuity between ABS actuator and electric unit (control unit) connector E125 terminals 16, 47 and ground.

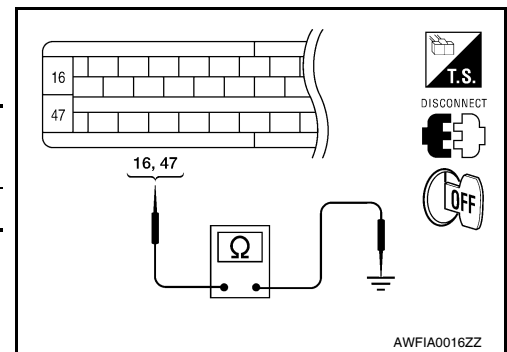

| ABS actuator and electric unit (control unit) | | — | Continuity |
|---|----------|--------|------------|
| Connector | Terminal | | |
| E125 | 16, 47 | Ground | Yes |

Is the inspection result normal?

- YES >> Replace ABS actuator and electric unit (control unit).
 Refer to [BRC-115, "Removal and Installation"](#).
 NO >> Repair or replace malfunctioning components.

Component Inspection

INFOID:000000006570222

1.CHECK ACTIVE TEST

1. Select each test menu item on "ACTIVE TEST".
2. On the display, touch "Up", "Keep", and "Down", and check that the system operates as shown in the table below.

| Operation | | ABS solenoid valve | | |
|-----------|---------------|--------------------|------|------|
| | | Up | Keep | Down |
| FR RH SOL | FR RH IN SOL | Off | On | On |
| | FR RH OUT SOL | Off | Off | On* |
| FR LH SOL | FR LH IN SOL | Off | On | On |
| | FR LH OUT SOL | Off | Off | On* |
| RR RH SOL | RR RH IN SOL | Off | On | On |
| | RR RH OUT SOL | Off | Off | On* |
| RR LH SOL | RR LH IN SOL | Off | On | On |
| | RR LH OUT SOL | Off | Off | On* |

*: On for 1 to 2 seconds after the touch, and then Off

Is the inspection result normal?

- YES >> Inspection End
 NO >> Go to diagnosis procedure. Refer to [BRC-50, "Diagnosis Procedure"](#).

Special Repair Requirement

INFOID:000000006570224

1.AJUSTMENT OF STEERING ANGLE SENSOR NEUTRAL POSITION

Always perform neutral position adjustment for the steering angle sensor when replacing the ABS actuator and electric unit (control unit). Refer to [BRC-8, "ADJUSTMENT OF STEERING ANGLE SENSOR NEUTRAL POSITION : Description"](#).

C1121, C1123, C1125, C1127 OUT ABS SOL

< DTC/CIRCUIT DIAGNOSIS >

[VDC/TCS/ABS]

>> GO TO 2

2. CALIBRATION OF DECEL G SENSOR

Always perform calibration of decel G sensor when replacing the ABS actuator and electric unit (control unit).
Refer to [BRC-9. "CALIBRATION OF DECEL G SENSOR : Description"](#).

>> END

C1130, C1131, C1132, C1133, C1136 ENGINE SIGNAL

< DTC/CIRCUIT DIAGNOSIS >

[VDC/TCS/ABS]

C1130, C1131, C1132, C1133, C1136 ENGINE SIGNAL

Description

INFOID:000000006147109

ABS actuator and electric unit (control unit) and ECM exchange the engine signal with CAN communication line.

DTC Logic

INFOID:000000006147110

DTC DETECTION LOGIC

| DTC | Display item | Malfunction detected condition | Possible cause |
|-------|-----------------|---|---|
| C1130 | ENGINE SIGNAL 1 | Based on the signal from ECM, ABS actuator and electric unit (control unit) judges that engine fuel cut system is malfunctioning. | <ul style="list-style-type: none">• Harness or connector• ABS actuator and electric unit (control unit)• ECM• CAN communication line |
| C1131 | ENGINE SIGNAL 2 | | |
| C1132 | ENGINE SIGNAL 3 | | |
| C1133 | ENGINE SIGNAL 4 | | |
| C1136 | ENGINE SIGNAL 6 | | |

DTC CONFIRMATION PROCEDURE

1. CHECK SELF-DIAGNOSIS RESULTS

Check the self-diagnosis results.

| Self-diagnosis results |
|------------------------|
| ENGINE SIGNAL 1 |
| ENGINE SIGNAL 2 |
| ENGINE SIGNAL 3 |
| ENGINE SIGNAL 4 |
| ENGINE SIGNAL 6 |

Is above displayed on the self-diagnosis display?

YES >> Proceed to diagnosis procedure. Refer to [BRC-53, "Diagnosis Procedure"](#).

NO >> Inspection End

Diagnosis Procedure

INFOID:000000006147111

1. CHECK ENGINE SYSTEM

1. Perform ECM self-diagnosis. Repair or replace items indicated, then perform ECM self-diagnosis again. Refer to [EC-50, "CONSULT-III Function"](#).
2. Perform ABS actuator and electric unit (control unit) self-diagnosis. Refer to [BRC-24, "CONSULT-III Function \(ABS\)"](#).

Is any item indicated on the self-diagnosis display?

YES >> Repair or replace the affected part.

NO >> Inspection End

Special Repair Requirement

INFOID:000000006570225

1. ADJUSTMENT OF STEERING ANGLE SENSOR NEUTRAL POSITION

Always perform neutral position adjustment for the steering angle sensor when replacing the ABS actuator and electric unit (control unit). Refer to [BRC-8, "ADJUSTMENT OF STEERING ANGLE SENSOR NEUTRAL POSITION : Description"](#).

>> GO TO 2

2. CALIBRATION OF DECEL G SENSOR

C1130, C1131, C1132, C1133, C1136 ENGINE SIGNAL

< DTC/CIRCUIT DIAGNOSIS >

[VDC/TCS/ABS]

Always perform calibration of decel G sensor when replacing the ABS actuator and electric unit (control unit).
Refer to [BRC-9, "CALIBRATION OF DECEL G SENSOR : Description"](#).

>> END

C1140 ACTUATOR RLY

< DTC/CIRCUIT DIAGNOSIS >

[VDC/TCS/ABS]

C1140 ACTUATOR RLY

Description

INFOID:000000006147113

Activates or deactivates each solenoid valve according to the signals transmitted by the ABS actuator and electric unit (control unit).

DTC Logic

INFOID:000000006147114

DTC DETECTION LOGIC

| DTC | Display item | Malfunction detected condition | Possible cause |
|-------|--------------|--|---|
| C1140 | ACTUATOR RLY | ABS actuator relay or circuit malfunction. | <ul style="list-style-type: none"> • Harness or connector • ABS actuator and electric unit (control unit) |

DTC CONFIRMATION PROCEDURE

1. CHECK SELF-DIAGNOSIS RESULTS

Check the self-diagnosis results.

| Self-diagnosis results |
|------------------------|
| ACTUATOR RLY |

Is above displayed on the self-diagnosis display?

- YES >> Proceed to diagnosis procedure. Refer to [BRC-55. "Diagnosis Procedure"](#).
 NO >> Inspection End

Diagnosis Procedure

INFOID:000000006570226

Regarding Wiring Diagram information, refer to [BRC-92. "Wiring Diagram"](#).

1. CONNECTOR INSPECTION

1. Turn ignition switch OFF.
2. Disconnect ABS actuator and electric unit (control unit) connector.
3. Check terminal for deformation, disconnection, looseness, and so on. If any malfunction is found, repair or replace terminal.
4. Reconnect connectors and then perform the self-diagnosis. Refer to [BRC-24. "CONSULT-III Function \(ABS\)"](#).

Is any item indicated on the self-diagnosis display?

- YES >> GO TO 2
 NO >> Poor connection of connector terminal. Repair or replace connector.

2. CHECK SOLENOID, VDC SWITCH-OVER VALVE AND ACTUATOR RELAY POWER SUPPLY CIRCUIT

1. Turn ignition switch OFF.
2. Disconnect ABS actuator and electric unit (control unit) connector.
3. Check voltage between ABS actuator and electric unit (control unit) connector E125 terminal 32 and ground.

| ABS actuator and electric unit (control unit) | | — | Voltage |
|---|----------|--------|-----------------|
| Connector | Terminal | | |
| E125 | 32 | Ground | Battery voltage |

Is the inspection result normal?

- YES >> GO TO 3

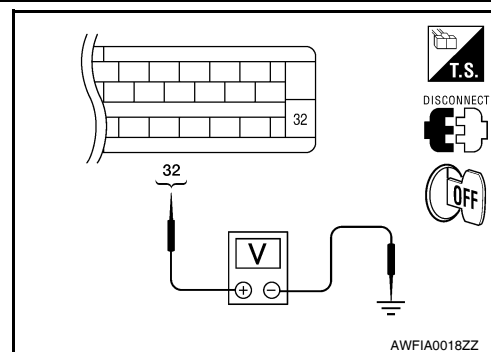

AWFIA0018ZZ

C1140 ACTUATOR RLY

[VDC/TCS/ABS]

< DTC/CIRCUIT DIAGNOSIS >

NO >> Repair or replace malfunctioning components.

3. CHECK SOLENOID, VDC SWITCH-OVER VALVE AND ACUATOR RELAY GROUND CIRCUIT

Check continuity between ABS actuator and electric unit (control unit) connector E125 terminals 16, 47 and ground.

| ABS actuator and electric unit (control unit) | | — | Continuity |
|---|----------|--------|------------|
| Connector | Terminal | | |
| E125 | 16, 47 | Ground | Yes |

Is the inspection result normal?

- YES >> Replace ABS actuator and electric unit (control unit).
Refer to [BRC-115, "Removal and Installation"](#).
- NO >> Repair or replace malfunctioning components.

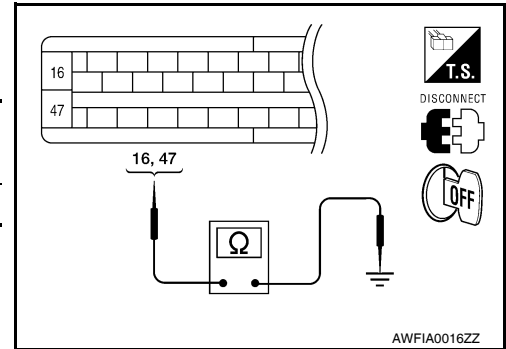

INFOID:000000006570227

Component Inspection

1. CHECK ACTIVE TEST

- On "ACTIVE TEST", select "ABS MOTOR".
- Touch "On" and "Off" on screen. Make sure motor relay and actuator relay operates as shown in table below.

| Operation | On | Off |
|--------------|----|-----|
| MOTOR RELAY | On | Off |
| ACTUATOR RLY | On | On |

Is the inspection result normal?

- YES >> Inspection End
- NO >> Go to diagnosis procedure. Refer to [BRC-55, "Diagnosis Procedure"](#).

INFOID:000000006570228

Special Repair Requirement

1. ADJUSTMENT OF STEERING ANGLE SENSOR NEUTRAL POSITION

Always perform neutral position adjustment for the steering angle sensor when replacing the ABS actuator and electric unit (control unit). Refer to [BRC-8, "ADJUSTMENT OF STEERING ANGLE SENSOR NEUTRAL POSITION : Description"](#).

>> GO TO 2

2. CALIBRATION OF DECEL G SENSOR

Always perform calibration of decel G sensor when replacing the ABS actuator and electric unit (control unit). Refer to [BRC-9, "CALIBRATION OF DECEL G SENSOR : Description"](#).

>> END

C1142 PRESS SENSOR

< DTC/CIRCUIT DIAGNOSIS >

[VDC/TCS/ABS]

C1142 PRESS SENSOR

Description

INFOID:000000006147118

The front and rear pressure sensors convert the brake fluid pressure to an electric signal and transmit it to the ABS actuator and electric unit (control unit).

DTC Logic

INFOID:000000006147119

DTC DETECTION LOGIC

| DTC | Display item | Malfunction detected condition | Possible cause |
|-------|-------------------|---|--|
| C1142 | PRESS SEN CIRCUIT | Pressure sensor signal line is open or shorted, or pressure sensor is malfunctioning. | <ul style="list-style-type: none"> • Harness or connector • Pressure sensor • ABS actuator and electric unit (control unit) |

DTC CONFIRMATION PROCEDURE

1. CHECK SELF-DIAGNOSIS RESULTS

Check the self-diagnosis results.

| |
|------------------------|
| Self-diagnosis results |
| PRESS SEN CIRCUIT |

Is above displayed on the self-diagnosis display?

YES >> Proceed to diagnosis procedure. Refer to [BRC-57. "Diagnosis Procedure \(Front Pressure Sensor\)"](#) or [BRC-58. "Diagnosis Procedure \(Rear Pressure Sensor\)"](#).

NO >> Inspection End

Diagnosis Procedure (Front Pressure Sensor)

INFOID:000000006147120

Regarding Wiring Diagram information, refer to [BRC-92. "Wiring Diagram"](#).

1. CONNECTOR INSPECTION

1. Turn the ignition switch OFF.
2. Disconnect the front pressure sensor connector and ABS actuator and electric unit (control unit) connector and inspect the terminals for deformation, disconnection, looseness, or damage.

Is the inspection result normal?

YES >> GO TO 2

NO >> Repair connector.

2. FRONT PRESSURE SENSOR CIRCUIT INSPECTION

1. Measure the continuity between the ABS actuator and electric unit (control unit) connector E125 (A) and front pressure sensor connector E31 (B).

| ABS actuator and electric unit (control unit) | | Front pressure sensor | | Continuity |
|---|----------|-----------------------|----------|------------|
| Connector | Terminal | Connector | Terminal | |
| E125 (A) | 18 | E31 (B) | 3 | Yes |
| | 19 | | 1 | |
| | 20 | | 2 | |

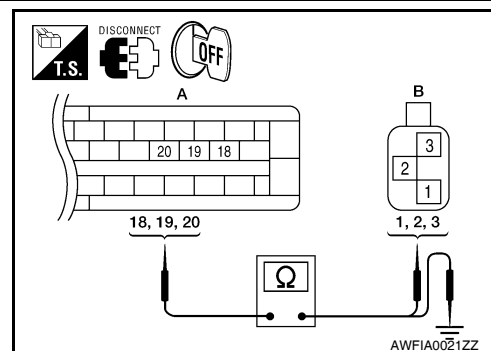

2. Measure the continuity between the ABS actuator and electric unit (control unit) connector E125 (A) and body ground.

C1142 PRESS SENSOR

< DTC/CIRCUIT DIAGNOSIS >

[VDC/TCS/ABS]

| ABS actuator and electric unit (control unit) | | — | Continuity |
|---|----------|--------|------------|
| Connector | Terminal | | |
| E125 (A) | 18 | Ground | No |
| | 19 | | |
| | 20 | | |

Is the inspection result normal?

- YES >> GO TO 3
- NO >> Repair or replace harness or connector.

3.FRONT PRESSURE SENSOR INSPECTION

1. Reconnect the front pressure sensor and ABS actuator and electric unit (control unit) connectors.
2. Perform PRESS SENSOR component inspection. Refer to [BRC-59, "Component Inspection \(Front Pressure Sensor\)"](#).

Is the inspection result normal?

- YES >> Inspection End.
- NO >> Replace the front pressure sensor.

Diagnosis Procedure (Rear Pressure Sensor)

INFOID:000000006570229

Regarding Wiring Diagram information, refer to [BRC-92, "Wiring Diagram"](#).

1.CONNECTOR INSPECTION

1. Turn the ignition switch OFF.
2. Disconnect the rear pressure sensor connector and ABS actuator and electric unit (control unit) connector and inspect the terminals for deformation, disconnection, looseness, or damage.

Is the inspection result normal?

- YES >> GO TO 2
- NO >> Repair connector.

2.REAR PRESSURE SENSOR CIRCUIT INSPECTION

1. Measure the continuity between the ABS actuator and electric unit (control unit) connector E125 (A) and rear pressure sensor connector E32 (B).

| ABS actuator and electric unit (control unit) | | Rear pressure sensor | | Continuity |
|---|----------|----------------------|----------|------------|
| Connector | Terminal | Connector | Terminal | |
| E125 (A) | 21 | E32 (B) | 1 | Yes |
| | 22 | | 3 | |
| | 23 | | 2 | |

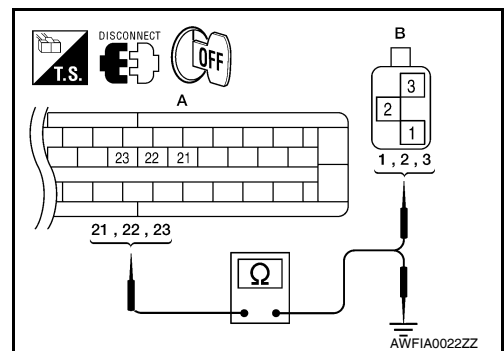

2. Measure the continuity between the ABS actuator and electric unit (control unit) connector E125 (A) and body ground.

| ABS actuator and electric unit (control unit) | | — | Continuity |
|---|----------|--------|------------|
| Connector | Terminal | | |
| E125 (B) | 21 | Ground | No |
| | 22 | | |
| | 23 | | |

C1142 PRESS SENSOR

[VDC/TCS/ABS]

< DTC/CIRCUIT DIAGNOSIS >

Is the inspection result normal?

- YES >> GO TO 3
- NO >> Repair or replace harness or connector.

3. REAR PRESSURE SENSOR INSPECTION

1. Reconnect the rear pressure sensor and ABS actuator and electric unit (control unit) connectors.
2. Perform PRESS SEN2 component inspection. Refer to [BRC-59, "Component Inspection \(Rear Pressure Sensor\)"](#).

Is the inspection result normal?

- YES >> Inspection End.
- NO >> Replace the rear pressure sensor.

Component Inspection (Front Pressure Sensor)

INFOID:000000006570230

1. CHECK DATA MONITOR

On "DATA MONITOR", select "PRESS SENSOR" and check the brake fluid pressure.

| Condition | PRESS SENSOR (DATA MONITOR) |
|--|--------------------------------|
| With ignition switch ON and brake pedal released. | Approx. 0 bar |
| With ignition switch ON and brake pedal depressed. | Positive value |

Is the inspection result normal?

- YES >> Inspection End
- NO >> Go to diagnosis procedure. Refer to [BRC-57, "Diagnosis Procedure \(Front Pressure Sensor\)"](#).

Component Inspection (Rear Pressure Sensor)

INFOID:000000006147121

1. CHECK DATA MONITOR

On "DATA MONITOR", select "PRESS SEN2" and check the brake fluid pressure.

| Condition | PRESS SEN2 (DATA MONITOR) |
|--|------------------------------|
| With ignition switch ON and brake pedal released. | Approx. 0 bar |
| With ignition switch ON and brake pedal depressed. | Positive value |

Is the inspection result normal?

- YES >> Inspection End
- NO >> Go to diagnosis procedure. Refer to [BRC-58, "Diagnosis Procedure \(Rear Pressure Sensor\)"](#).

C1143, C1144 STEERING ANGLE SENSOR

< DTC/CIRCUIT DIAGNOSIS >

[VDC/TCS/ABS]

C1143, C1144 STEERING ANGLE SENSOR

Description

INFOID:000000006147122

The steering angle sensor detects the rotation amount, angular velocity and direction of the steering wheel, and transmits the data to the ABS actuator and electric unit (control unit) via CAN communication.

DTC Logic

INFOID:000000006147123

DTC DETECTION LOGIC

| DTC | Display item | Malfunction detected condition | Possible cause |
|-------|--------------------|--|--|
| C1143 | ST ANG SEN CIRCUIT | Neutral position of steering angle sensor is dislocated, or the steering angle sensor is malfunctioning. | <ul style="list-style-type: none">• Harness or connector• Steering angle sensor• ABS actuator and electric unit (control unit) |
| C1144 | ST ANG SEN SIGNAL | Neutral position of steering angle sensor is not finished. | |

DTC CONFIRMATION PROCEDURE

1. CHECK SELF-DIAGNOSIS RESULTS

Check the self-diagnosis results.

| |
|------------------------|
| Self-diagnosis results |
| ST ANG SEN CIRCUIT |
| ST ANG SEN SIGNAL |

Is above displayed on the self-diagnosis display?

- YES >> Proceed to diagnosis procedure. Refer to [BRC-60, "Diagnosis Procedure"](#).
NO >> Inspection End

Diagnosis Procedure

INFOID:000000006147124

Regarding Wiring Diagram information, refer to [BRC-92, "Wiring Diagram"](#).

1. CONNECTOR INSPECTION

1. Turn ignition switch OFF.
2. Disconnect ABS actuator and electric unit (control unit) connector.
3. Disconnect steering angle sensor connector.
4. Check terminal for deformation, disconnection, looseness, and so on. If any malfunction is found, repair or replace terminal.
5. Reconnect connectors and then perform the self-diagnosis. Refer to [BRC-24, "CONSULT-III Function \(ABS\)"](#).

Is any item indicated on the self-diagnosis display?

- YES >> GO TO 2
NO >> Poor connection of connector terminal. Repair or replace connector.

2. CHECK STEERING ANGLE SENSOR HARNESS

1. Turn ignition switch OFF.
2. Disconnect steering angle sensor connector.

C1143, C1144 STEERING ANGLE SENSOR

[VDC/TCS/ABS]

< DTC/CIRCUIT DIAGNOSIS >

- Check continuity between steering angle sensor connector M17 terminal 2 and ground.

| Steering angle sensor | | — | Continuity |
|-----------------------|----------|--------|------------|
| Connector | Terminal | | |
| M17 | 2 | Ground | Yes |

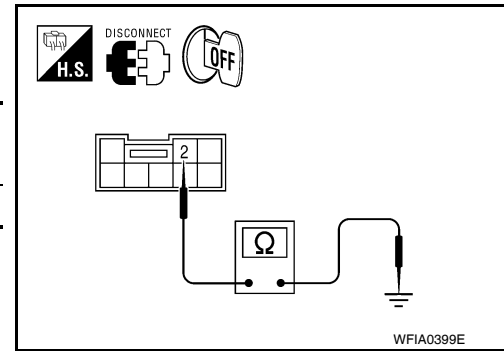

- Turn ignition switch ON.
- Check voltage between steering angle sensor connector M17 terminal 3 and ground.

| Steering angle sensor | | — | Voltage |
|-----------------------|----------|--------|-----------------|
| Connector | Terminal | | |
| M17 | 3 | Ground | Battery voltage |

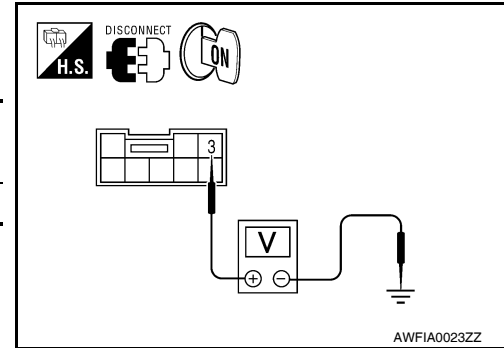

Is the inspection result normal?

- YES >> GO TO 3
- NO >> Repair or replace malfunctioning components.

3. STEERING ANGLE SENSOR INSPECTION

- Connect the steering angle sensor connector and ABS actuator and electric unit (control unit) connector.
- Perform the steering angle sensor component inspection. Refer to [BRC-61, "Component Inspection"](#).

Is the inspection result normal?

- YES >> Replace ABS actuator and electric unit (control unit). Refer to [BRC-115, "Removal and Installation"](#).
- NO >> Replace steering angle sensor and adjust neutral position of steering angle sensor. Refer to [BRC-117, "Removal and Installation"](#).

Component Inspection

INFOID:000000006147125

1. CHECK DATA MONITOR

Select "STR ANGLE SIG" in "DATA MONITOR" and check steering angle sensor signal.

| Steering condition | STR ANGLE SIG (DATA MONITOR) |
|--------------------|------------------------------|
| Driving straight | 0±2.5 ° |
| Turn 90 ° to left | Approx. +90 ° |
| Turn 90 ° to right | Approx. -90 ° |

Is the inspection result normal?

- YES >> Inspection End
- NO >> Go to diagnosis procedure. Refer to [BRC-60, "Diagnosis Procedure"](#).

Special Repair Requirement

INFOID:000000006570231

1. ADJUSTMENT OF STEERING ANGLE SENSOR NEUTRAL POSITION

Always perform neutral position adjustment for the steering angle sensor when replacing the ABS actuator and electric unit (control unit). Refer to [BRC-8, "ADJUSTMENT OF STEERING ANGLE SENSOR NEUTRAL POSITION : Description"](#).

>> GO TO 2

C1143, C1144 STEERING ANGLE SENSOR

< DTC/CIRCUIT DIAGNOSIS >

[VDC/TCS/ABS]

2. CALIBRATION OF DECEL G SENSOR

Always perform calibration of decel G sensor when replacing the ABS actuator and electric unit (control unit).
Refer to [BRC-9, "CALIBRATION OF DECEL G SENSOR : Description"](#).

>> END

C1155 BRAKE FLUID LEVEL SWITCH

< DTC/CIRCUIT DIAGNOSIS >

[VDC/TCS/ABS]

C1155 BRAKE FLUID LEVEL SWITCH

Description

INFOID:000000006147127

The brake fluid level switch converts the brake fluid level to an electric signal and transmits it to the ABS actuator and electric unit (control unit).

DTC Logic

INFOID:000000006147128

DTC DETECTION LOGIC

| DTC | Display item | Malfunction detected condition | Possible cause |
|-------|--------------------|---|---|
| C1155 | BR FLUID LEVEL LOW | Brake fluid level is low or communication line between the ABS actuator and electric unit (control unit) and brake fluid level switch is open or shorted. | <ul style="list-style-type: none"> • Harness or connector • Brake fluid level switch • Brake fluid level |

DTC CONFIRMATION PROCEDURE

1. CHECK SELF-DIAGNOSIS RESULTS

Check the self-diagnosis results.

| Self-diagnosis results |
|------------------------|
| BR FLUID LEVEL LOW |

Is above displayed on the self-diagnosis display?

- YES >> Proceed to diagnosis procedure. Refer to [BRC-63. "Diagnosis Procedure"](#).
 NO >> Inspection End

Diagnosis Procedure

INFOID:000000006147129

Regarding Wiring Diagram information, refer to [BRC-92. "Wiring Diagram"](#).

1. CONNECTOR INSPECTION

1. Disconnect ABS actuator and electric unit (control unit) connector and brake fluid level switch connector.
2. Check the terminals for deformation, disconnection, looseness or damage.

Is the inspection result normal?

- YES >> GO TO 2
 NO >> Repair or replace as necessary.

2. CHECK HARNESS BETWEEN BRAKE FLUID LEVEL SWITCH AND ABS ACTUATOR AND ELECTRIC UNIT (CONTROL UNIT)

1. Check continuity between ABS actuator and electric unit (control unit) connector E125 (A) terminal 8 and brake fluid level switch connector E21 (B) terminal 1.

| ABS actuator and electric unit (control unit) | | Brake fluid level switch | | Continuity |
|---|----------|--------------------------|----------|------------|
| Connector | Terminal | Connector | Terminal | |
| E125 (A) | 8 | E21 (B) | 1 | Yes |

2. Check continuity between ABS actuator and electric unit (control unit) connector E125 (A) terminal 8 and ground.

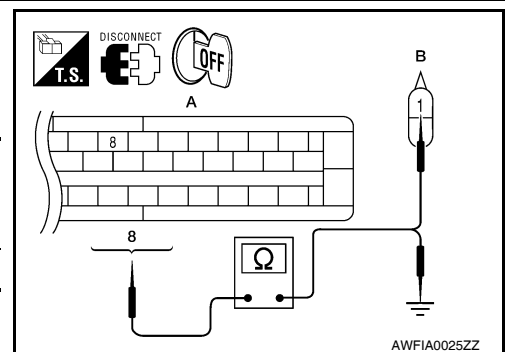

C1155 BRAKE FLUID LEVEL SWITCH

< DTC/CIRCUIT DIAGNOSIS >

[VDC/TCS/ABS]

| | | | |
|---|----------|--------|------------|
| ABS actuator and electric unit (control unit) | | — | Continuity |
| Connector | Terminal | | |
| E125 (A) | 8 | Ground | No |

Is the inspection result normal?

- YES >> GO TO 3
- NO >> Repair or replace malfunctioning components.

3.CHECK BRAKE FLUID LEVEL SWITCH GROUND

Check continuity between brake fluid level switch connector E21 terminal 2 and ground.

| | | | |
|--------------------------|----------|--------|------------|
| Brake fluid level switch | | — | Continuity |
| Connector | Terminal | | |
| E21 | 2 | Ground | Yes |

Is the inspection result normal?

- YES >> GO TO 4
- NO >> Repair or replace malfunctioning components.

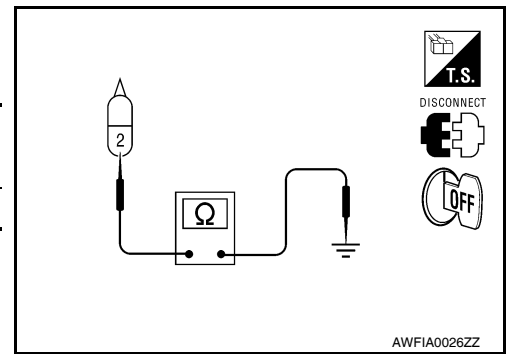

4.CHECK BRAKE FLUID LEVEL SWITCH

Perform the brake fluid level switch component inspection. Refer to [BRC-64, "Component Inspection"](#).

Is the inspection result normal?

- YES >> Perform self-diagnosis again. If the same results appear, replace ABS actuator and electric unit (control unit). Refer to [BRC-115, "Removal and Installation"](#).
- NO >> Replace brake fluid level switch.

Component Inspection

INFOID:000000006147130

1.CHECK BRAKE FLUID LEVEL SWITCH

1. Turn ignition switch OFF.
2. Disconnect brake fluid level switch connector.
3. Check continuity between brake fluid level switch terminals.

| | | |
|--------------------------|--------------------------------------|------------|
| Brake fluid level switch | Condition | Continuity |
| Terminal | | |
| 1 - 2 | When brake fluid reservoir is full. | No |
| | When brake fluid reservoir is empty. | Yes |

Is the inspection result normal?

- YES >> Inspection End
- NO >> Replace brake fluid level switch.

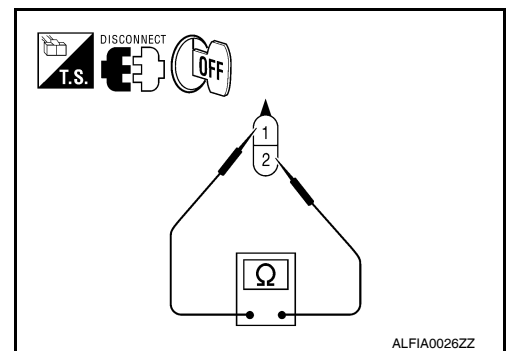

Special Repair Requirement

INFOID:000000006570232

1.ADJUSTMENT OF STEERING ANGLE SENSOR NEUTRAL POSITION

Always perform neutral position adjustment for the steering angle sensor when replacing the ABS actuator and electric unit (control unit). Refer to [BRC-8, "ADJUSTMENT OF STEERING ANGLE SENSOR NEUTRAL POSITION : Description"](#).

>> GO TO 2

2.CALIBRATION OF DECEL G SENSOR

Always perform calibration of decel G sensor when replacing the ABS actuator and electric unit (control unit). Refer to [BRC-9, "CALIBRATION OF DECEL G SENSOR : Description"](#).

C1155 BRAKE FLUID LEVEL SWITCH

< DTC/CIRCUIT DIAGNOSIS >

[VDC/TCS/ABS]

>> END

A

B

C

D

E

BRC

G

H

I

J

K

L

M

N

O

P

C1156 ST ANG SEN COM CIR

Description

INFOID:000000006147132

The steering angle sensor is connected to the ABS actuator and electric unit (control unit) in addition to CAN lines. CAN (Controller Area Network) is a serial communication line for real time application. It is an on-vehicle multiplex communication line with high data communication speed and excellent error detection ability. Many electronic control units are equipped onto a vehicle, and each control unit shares information and links with other control units during operation (not independent). In CAN communication, control units are connected with 2 communication lines (CAN H line, CAN L line) allowing a high rate of information transmission with less wiring. Each control unit transmits/receives data but selectively reads required data only.

DTC Logic

INFOID:000000006147133

DTC DETECTION LOGIC

| DTC | Display item | Malfunction detected condition | Possible cause |
|-------|--------------------|---|--|
| C1156 | ST ANG SEN COM CIR | When steering angle sensor is not transmitting CAN communication signal to the ABS actuator and electric unit (control unit). | <ul style="list-style-type: none"> Harness or connector CAN communication line Steering angle sensor ABS actuator and electric unit (control unit) |

DTC CONFIRMATION PROCEDURE

1. CHECK SELF-DIAGNOSIS RESULTS

Check the self-diagnosis results.

| |
|------------------------|
| Self-diagnosis results |
| ST ANG SEN COM CIR |

Is above displayed on the self-diagnosis display?

- YES >> Proceed to diagnosis procedure. Refer to [BRC-66, "Diagnosis Procedure"](#).
 NO >> Inspection End

Diagnosis Procedure

INFOID:000000006147134

1. CHECK CONNECTOR

1. Turn ignition switch OFF and disconnect ABS actuator and electric unit (control unit) connector, check terminal for deformation, disconnection, looseness, and so on. If any malfunction is found, repair or replace terminal.
2. Reconnect connector and perform self-diagnosis.

| |
|------------------------|
| Self-diagnosis results |
| CAN COMM CIRCUIT |
| ST ANG SEN COM CIR |

Is above displayed on the self-diagnosis display?

- YES >> Refer to [LAN-14, "Trouble Diagnosis Flow Chart"](#).
 NO >> Inspection End

C1160 DECEL G SEN SET

< DTC/CIRCUIT DIAGNOSIS >

[VDC/TCS/ABS]

C1160 DECEL G SEN SET

Description

INFOID:000000006147135

The yaw rate/side/decel G sensor detects the yaw rate/side/decel G affecting the vehicle, and transmits the data to the ABS actuator and electric unit (control unit) as an analog voltage signal.

DTC Logic

INFOID:000000006147136

DTC DETECTION LOGIC

| DTC | Display item | Malfunction detected condition | Possible cause |
|-------|-----------------|--|---|
| C1160 | DECEL G SEN SET | ABS decel G sensor adjustment is incomplete. | <ul style="list-style-type: none">Decel G sensor calibrationYaw rate/side/decel G sensorABS actuator and electric unit (control unit) |

DTC CONFIRMATION PROCEDURE

1. CHECK SELF-DIAGNOSIS RESULTS

Check the self-diagnosis results.

| |
|------------------------|
| Self-diagnosis results |
| DECEL G SEN SET |

Is above displayed on the self-diagnosis display?

- YES >> Proceed to diagnosis procedure. Refer to [BRC-67, "Diagnosis Procedure"](#).
NO >> Inspection End

Diagnosis Procedure

INFOID:000000006147137

1. PERFORM SELF-DIAGNOSIS

Perform ABS actuator and electric unit (control unit) self-diagnosis.

| |
|------------------------|
| Self-diagnosis results |
| DECEL G SEN SET |

Do self-diagnosis results indicate anything other than shown above?

- YES >> Perform repair or replacement for the item indicated.
NO >> Perform calibration of decel G sensor. Refer to [BRC-9, "CALIBRATION OF DECEL G SENSOR : Description"](#). GO TO 2

2. PERFORM SELF-DIAGNOSIS AGAIN

- Turn the ignition switch to OFF and then to ON and erase self-diagnosis results.
- Perform ABS actuator and electric unit (control unit) self-diagnosis again. Refer to [BRC-24, "CONSULT-III Function \(ABS\)"](#).

Are any self-diagnosis results displayed?

- YES >> Replace yaw rate/side/decel G sensor. Refer to [BRC-118, "Removal and Installation"](#).
NO >> Inspection End

C1163 ST ANGLE SEN SAFE

< DTC/CIRCUIT DIAGNOSIS >

[VDC/TCS/ABS]

C1163 ST ANGLE SEN SAFE

Description

INFOID:000000006147138

The steering angle sensor detects the rotation amount, angular velocity and direction of the steering wheel, and transmits the data to the ABS actuator and electric unit (control unit) via CAN communication.

DTC Logic

INFOID:000000006147139

DTC DETECTION LOGIC

| DTC | Display item | Malfunction detected condition | Possible cause |
|-------|------------------|---|---|
| C1163 | ST ANGL SEN SAFE | When steering angle sensor is in safe mode. | • Adjust steering angle sensor neutral position |

DTC CONFIRMATION PROCEDURE

1.CHECK SELF-DIAGNOSIS RESULTS

Check the self-diagnosis results.

| |
|------------------------|
| Self-diagnosis results |
| ST ANGL SEN SAFE |

Is above displayed on the self-diagnosis display?

- YES >> Proceed to diagnosis procedure. Refer to [BRC-68. "Diagnosis Procedure"](#).
NO >> Inspection End

Diagnosis Procedure

INFOID:000000006147140

1.ADJUSTMENT OF STEERING ANGLE SENSOR NEUTRAL POSITION

Adjust steering angle sensor neutral position. Refer to [BRC-8. "ADJUSTMENT OF STEERING ANGLE SENSOR NEUTRAL POSITION : Description"](#).

>> GO TO 2

2.INDICATOR LAMP CHECK

Check that VDC OFF indicator lamp is off.

Is VDC OFF indicator lamp off?

- YES >> Inspection End
NO >> Perform ABS actuator and electric unit (control unit) self-diagnosis. Refer to [BRC-24. "CONSULT-III Function \(ABS\)"](#).

C1164, C1165, C1166, C1167 CV/SV SYSTEM

< DTC/CIRCUIT DIAGNOSIS >

[VDC/TCS/ABS]

C1164, C1165, C1166, C1167 CV/SV SYSTEM

Description

INFOID:000000006147141

CV1, CV2 (CUT VALVE)

The cut valve shuts off the normal brake fluid path from the master cylinder, when VDC/TCS is activated.

SV1, SV2 (SUCTION VALVE)

The suction valve supplies the brake fluid from the master cylinder to the pump, when VDC/TCS is activated.

DTC Logic

INFOID:000000006147142

DTC DETECTION LOGIC

| DTC | Display item | Malfunction detected condition | Possible cause |
|-------|--------------|--|--|
| C1164 | CV1 | VDC switch-over solenoid valve (CV1) on the primary side is open circuit or shorted, or the control line is open or shorted to the power supply or the ground. | <ul style="list-style-type: none">• Harness or connector• ABS actuator and electric unit (control unit) |
| C1165 | CV2 | VDC switch-over solenoid valve (CV2) on the primary side is open circuit or shorted, or the control line is open or shorted to the power supply or the ground. | |
| C1166 | SV1 | VDC switch-over solenoid valve (SV1) on the primary side is open circuit or shorted, or the control line is open or shorted to the power supply or the ground. | |
| C1167 | SV2 | VDC switch-over solenoid valve (SV2) on the primary side is open circuit or shorted, or the control line is open or shorted to the power supply or the ground. | |

DTC CONFIRMATION PROCEDURE

1. CHECK SELF-DIAGNOSIS RESULTS

Check the self-diagnosis results.

| Self-diagnosis results |
|------------------------|
| CV1 |
| CV2 |
| SV1 |
| SV2 |

Is above displayed on the self-diagnosis display?

- YES >> Proceed to diagnosis procedure. Refer to [BRC-69. "Diagnosis Procedure"](#).
NO >> Inspection End

Diagnosis Procedure

INFOID:000000006570233

Regarding Wiring Diagram information, refer to [BRC-92. "Wiring Diagram"](#).

1. CONNECTOR INSPECTION

1. Turn ignition switch OFF.
2. Disconnect ABS actuator and electric unit (control unit) connector.
3. Check terminal for deformation, disconnection, looseness, and so on. If any malfunction is found, repair or replace terminal.
4. Reconnect connectors and then perform the self-diagnosis. Refer to [BRC-24. "CONSULT-III Function \(ABS\)"](#).

Is any item indicated on the self-diagnosis display?

C1164, C1165, C1166, C1167 CV/SV SYSTEM

< DTC/CIRCUIT DIAGNOSIS >

[VDC/TCS/ABS]

YES >> GO TO 2

NO >> Poor connection of connector terminal. Repair or replace connector.

2. CHECK SOLENOID, VDC SWITCH-OVER VALVE AND ACTUATOR RELAY POWER SUPPLY CIRCUIT

1. Turn ignition switch OFF.
2. Disconnect ABS actuator and electric unit (control unit) connector.
3. Check voltage between ABS actuator and electric unit (control unit) connector E125 terminal 32 and ground.

| ABS actuator and electric unit (control unit) | | — | Voltage |
|---|----------|--------|-----------------|
| Connector | Terminal | | |
| E125 | 32 | Ground | Battery voltage |

Is the inspection result normal?

YES >> GO TO 3

NO >> Repair or replace malfunctioning components.

3. CHECK SOLENOID, VDC SWITCH-OVER VALVE AND ACUATOR RELAY GROUND CIRCUIT

Check continuity between ABS actuator and electric unit (control unit) connector E125 terminals 16, 47 and ground.

| ABS actuator and electric unit (control unit) | | — | Continuity |
|---|----------|--------|------------|
| Connector | Terminal | | |
| E125 | 16, 47 | Ground | Yes |

Is the inspection result normal?

YES >> Replace ABS actuator and electric unit (control unit).
Refer to [BRC-115. "Removal and Installation"](#).

NO >> Repair or replace malfunctioning components.

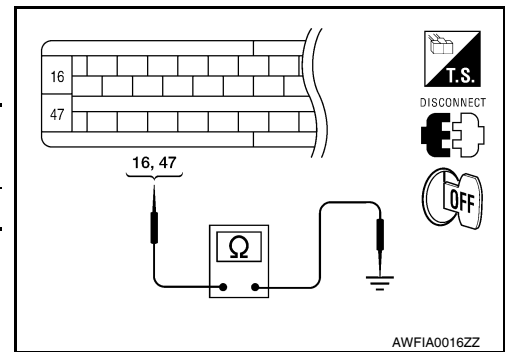
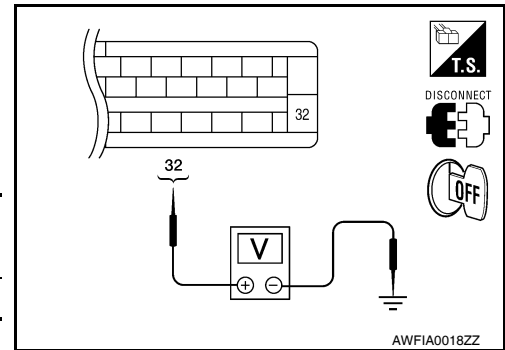

Component Inspection

INFOID:000000006147144

1. CHECK ACTIVE TEST

1. Select each test menu item on "ACTIVE TEST".
2. On the display, touch "Up", "ACT UP", and "ACT KEEP", and check that the system operates as shown in the table below.

| Operation | | ABS solenoid valve (ACT) | | |
|--------------------------|---------------|--------------------------|--------|----------|
| | | Up | ACT UP | ACT KEEP |
| FR RH ABS SOLENOID (ACT) | FR RH IN SOL | Off | Off | Off |
| | FR RH OUT SOL | Off | Off | Off |
| | CV1 | Off | On | On |
| | SV1 | Off | On* | Off |
| FR LH ABS SOLENOID (ACT) | FR LH IN SOL | Off | Off | Off |
| | FR LH OUT SOL | Off | Off | Off |
| | CV1 | Off | On | On |
| | SV1 | Off | On* | Off |
| RR RH ABS SOLENOID (ACT) | RR RH IN SOL | Off | Off | Off |
| | RR RH OUT SOL | Off | Off | Off |
| | CV2 | Off | On | On |
| | SV2 | Off | On* | Off |

C1164, C1165, C1166, C1167 CV/SV SYSTEM

< DTC/CIRCUIT DIAGNOSIS >

[VDC/TCS/ABS]

| Operation | | ABS solenoid valve (ACT) | | |
|--------------------------|---------------|--------------------------|--------|----------|
| | | Up | ACT UP | ACT KEEP |
| RR LH ABS SOLENOID (ACT) | RR LH IN SOL | Off | Off | Off |
| | RR LH OUT SOL | Off | Off | Off |
| | CV2 | Off | On | On |
| | SV2 | Off | On* | Off |

*: On for 1 to 2 seconds after the touch, and then Off

Is the inspection result normal?

YES >> Inspection End

NO >> Go to diagnosis procedure. Refer to [BRC-69, "Diagnosis Procedure"](#).

Special Repair Requirement

INFOID:000000006570234

1. ADJUSTMENT OF STEERING ANGLE SENSOR NEUTRAL POSITION

Always perform neutral position adjustment for the steering angle sensor when replacing the ABS actuator and electric unit (control unit). Refer to [BRC-8, "ADJUSTMENT OF STEERING ANGLE SENSOR NEUTRAL POSITION : Description"](#).

>> GO TO 2

2. CALIBRATION OF DECEL G SENSOR

Always perform calibration of decel G sensor when replacing the ABS actuator and electric unit (control unit). Refer to [BRC-9, "CALIBRATION OF DECEL G SENSOR : Description"](#).

>> END

C1178, C1181, C1184, C1189 ABS ACTIVE BOOSTER

< DTC/CIRCUIT DIAGNOSIS >

[VDC/TCS/ABS]

C1178, C1181, C1184, C1189 ABS ACTIVE BOOSTER

Description

INFOID:000000006147146

The active brake booster consists of a vacuum booster, an active booster control group and a delta stroke sensor. If a brake booster system malfunction occurs due to loss of vacuum, the delta stroke sensor will signal the ABS actuator and electric unit (control unit) that a booster malfunction has occurred. The active booster then applies supplemental force to the master cylinder relative to the amount of force exerted on the brake pedal.

DTC Logic

INFOID:000000006147147

DTC DETECTION LOGIC

| DTC | Display item | Malfunction detected condition | Possible cause |
|-------|--------------------------------|--|---|
| C1178 | ABS ACTIVE BOOSTER SV NG | Active booster solenoid is malfunctioning, or signal line of active booster servo is open or shorted. | <ul style="list-style-type: none">• Harness or connector• Active booster• ABS actuator and electric unit (control unit) |
| C1181 | ABS ACTIVE BOOSTER RESPONSE NG | Active booster response is malfunctioning, or signal line of active booster response is open or shorted. | |
| C1184 | ABS BRAKE RELEASE SW NG | Brake release switch is malfunctioning, or signal line of brake release switch is open or shorted. | |
| C1189 | ABS BRAKE BOOSTER DEFECT | Brake booster is defective or malfunctioning. | |

DTC CONFIRMATION PROCEDURE

1. CHECK SELF-DIAGNOSIS RESULTS

Check the self-diagnosis results.

| |
|--------------------------------|
| Self-diagnosis results |
| ABS ACTIVE BOOSTER SV NG |
| ABS ACTIVE BOOSTER RESPONSE NG |
| ABS BRAKE RELEASE SW NG |
| ABS BRAKE BOOSTER DEFECT |

Is above displayed on the self-diagnosis display?

YES >> Proceed to diagnosis procedure. Refer to [BRC-72. "Diagnosis Procedure"](#).

NO >> Inspection End

Diagnosis Procedure

INFOID:000000006147148

Regarding Wiring Diagram information, refer to [BRC-92. "Wiring Diagram"](#).

1. CONNECTOR INSPECTION

1. Turn the ignition switch OFF.
2. Disconnect the active booster connector and ABS actuator and electric unit (control unit) connector and inspect the terminals for deformation, disconnection, looseness, or damage.

Is the inspection result normal?

YES >> GO TO 2

NO >> Repair connector.

2. ACTIVE BOOSTER CIRCUIT INSPECTION

C1178, C1181, C1184, C1189 ABS ACTIVE BOOSTER

< DTC/CIRCUIT DIAGNOSIS >

[VDC/TCS/ABS]

1. Measure the continuity between ABS actuator and electric unit (control unit) connector E125 (A) and active booster connector E49 (B).

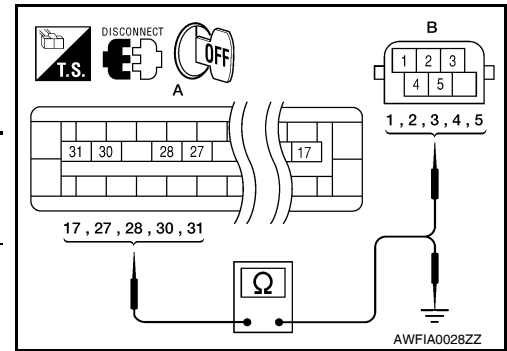

| ABS actuator and electric unit (control unit) | | Active booster | | Continuity |
|---|----------|----------------|----------|------------|
| Connector | Terminal | Connector | Terminal | |
| E125 (A) | 17 | E49 (B) | 3 | Yes |
| | 27 | | 1 | |
| | 28 | | 5 | |
| | 30 | | 2 | |
| | 31 | | 4 | |

2. Measure the continuity between ABS actuator and electric unit (control unit) connector E125 (A) and body ground.

| ABS actuator and electric unit (control unit) | | — | Continuity |
|---|----------|--------|------------|
| Connector | Terminal | | |
| E125 (A) | 17 | Ground | No |
| | 27 | | |
| | 28 | | |
| | 30 | | |
| | 31 | | |

Is the inspection result normal?

- YES >> GO TO 3
- NO >> Repair or replace harness or connector.

3. ACTIVE BOOSTER INSPECTION

1. Reconnect the active booster and ABS actuator and electric unit (control unit) connectors.
2. Perform the active booster component inspection. Refer to [BRC-73, "Component Inspection"](#).

Is the inspection result normal?

- YES >> Replace the ABS actuator and electric unit (control unit). Refer to [BRC-115, "Removal and Installation"](#).
- NO >> Replace the active booster. Refer to [BR-27, "Removal and Installation"](#).

Component Inspection

INFOID:000000006147149

1. CHECK DATA MONITOR

Use "DATA MONITOR" to check if the status of "RELEASE SWITCH NO" and "RELEASE SWITCH NC" is normal.

| Condition | RELEASE SWITCH NO (DATA MONITOR) | RELEASE SWITCH NC (DATA MONITOR) |
|--------------------------------|----------------------------------|----------------------------------|
| When brake pedal is depressed. | On | Off |
| When brake pedal is released. | Off | On |

Is the inspection result normal?

- YES >> Inspection End
- NO >> Go to diagnosis procedure. Refer to [BRC-72, "Diagnosis Procedure"](#).

Special Repair Requirement

INFOID:000000006570235

1. ADJUSTMENT OF STEERING ANGLE SENSOR NEUTRAL POSITION

C1178, C1181, C1184, C1189 ABS ACTIVE BOOSTER

< DTC/CIRCUIT DIAGNOSIS >

[VDC/TCS/ABS]

Always perform neutral position adjustment for the steering angle sensor when replacing the ABS actuator and electric unit (control unit). Refer to [BRC-8, "ADJUSTMENT OF STEERING ANGLE SENSOR NEUTRAL POSITION : Description"](#).

>> GO TO 2

2. CALIBRATION OF DECEL G SENSOR

Always perform calibration of decel G sensor when replacing the ABS actuator and electric unit (control unit). Refer to [BRC-9, "CALIBRATION OF DECEL G SENSOR : Description"](#).

>> END

C1179 ABS DELTA S SEN NG

Description

INFOID:000000006147151

The active brake booster consists of a vacuum booster, an active booster control group and a delta stroke sensor. If a brake booster system malfunction occurs due to loss of vacuum, the delta stroke sensor will signal the ABS actuator and electric unit (control unit) that a booster malfunction has occurred. The active booster then applies supplemental force to the master cylinder relative to the amount of force exerted on the brake pedal.

DTC Logic

INFOID:000000006147152

DTC DETECTION LOGIC

| DTC | Display item | Malfunction detected condition | Possible cause |
|-------|--------------------|--|--|
| C1179 | ABS DELTA S SEN NG | Delta stroke sensor is malfunctioning, or signal line of delta stroke sensor is open or shorted. | <ul style="list-style-type: none"> • Harness or connector • Delta stroke sensor • ABS actuator and electric unit (control unit) |

A
B
C
D
E
BRC

DTC CONFIRMATION PROCEDURE

1.CHECK SELF-DIAGNOSIS RESULTS

Check the self-diagnosis results.

| |
|------------------------|
| Self-diagnosis results |
| ABS DELTA S SEN NG |

Is above displayed on the self-diagnosis display?

- YES >> Proceed to diagnosis procedure. Refer to [BRC-75. "Diagnosis Procedure"](#).
- NO >> Inspection End

Diagnosis Procedure

INFOID:000000006147153

Regarding Wiring Diagram information, refer to [BRC-92. "Wiring Diagram"](#).

1.CONNECTOR INSPECTION

1. Turn the ignition switch OFF.
2. Disconnect the delta stroke sensor connector and ABS actuator and electric unit (control unit) connector and inspect the terminals for deformation, disconnection, looseness, or damage.

Is the inspection result normal?

- YES >> GO TO 2
- NO >> Repair connector.

2.DELTA STROKE SENSOR CIRCUIT INSPECTION

1. Measure the continuity between ABS actuator and electric unit (control unit) connector E125 (A) and delta stroke sensor connector E114 (B).

| ABS actuator and electric unit (control unit) | | Delta stroke sensor | | Continuity |
|---|----------|---------------------|----------|------------|
| Connector | Terminal | Connector | Terminal | |
| A: E125 | 26 | B: E114 | 1 | Yes |
| | 39 | | 3 | |
| | 40 | | 5 | |

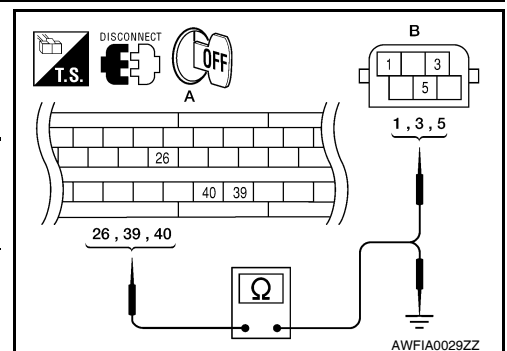

J
K
L
M
N
O
P

C1179 ABS DELTA S SEN NG

[VDC/TCS/ABS]

< DTC/CIRCUIT DIAGNOSIS >

2. Measure the continuity between ABS actuator and electric unit (control unit) connector E125 (A) and body ground.

| ABS actuator and electric unit (control unit) | | — | Continuity |
|---|----------|--------|------------|
| Connector | Terminal | | |
| A: E125 | 26 | Ground | No |
| | 39 | | |
| | 40 | | |

Is the inspection result normal?

YES >> GO TO 3

NO >> Repair or replace harness or connector.

3.DELTA STROKE SENSOR INSPECTION

1. Reconnect the delta stroke sensor and ABS actuator and electric unit (control unit) connectors.
2. Perform the delta stroke sensor component inspection. Refer to [BRC-76. "Component Inspection"](#).

Is the inspection result normal?

YES >> Replace the ABS actuator and electric unit (control unit). Refer to [BRC-115. "Removal and Installation"](#).

NO >> Replace the delta stroke sensor.

Component Inspection

INFOID:000000006147154

1.CHECK DATA MONITOR

Use "DATA MONITOR" to check if the status of "DELTA S SEN" is normal.

| Condition | DELTA S SEN (DATA MONITOR) |
|--------------------------------|-------------------------------|
| When brake pedal is depressed. | 1.05–1.80 mm |
| When brake pedal is released. | 0.00 mm (+0.6/-0.4) |

Is the inspection result normal?

YES >> Inspection End

NO >> Go to diagnosis procedure. Refer to [BRC-75. "Diagnosis Procedure"](#).

Special Repair Requirement

INFOID:000000006570236

1.AJUSTMENT OF STEERING ANGLE SENSOR NEUTRAL POSITION

Always perform neutral position adjustment for the steering angle sensor when replacing the ABS actuator and electric unit (control unit). Refer to [BRC-8. "ADJUSTMENT OF STEERING ANGLE SENSOR NEUTRAL POSITION : Description"](#).

>> GO TO 2

2.CALIBRATION OF DECEL G SENSOR

Always perform calibration of decel G sensor when replacing the ABS actuator and electric unit (control unit). Refer to [BRC-9. "CALIBRATION OF DECEL G SENSOR : Description"](#).

>> END

U1000 CAN COMM CIRCUIT

< DTC/CIRCUIT DIAGNOSIS >

[VDC/TCS/ABS]

U1000 CAN COMM CIRCUIT

Description

INFOID:000000006147156

CAN (Controller Area Network) is a serial communication line for real time application. It is an on-vehicle multiplex communication line with high data communication speed and excellent error detection ability. Many electronic control units are equipped onto a vehicle, and each control unit shares information and links with other control units during operation (not independent). In CAN communication, control units are connected with 2 communication lines (CAN H line, CAN L line) allowing a high rate of information transmission with less wiring. Each control unit transmits/receives data but selectively reads required data only.

DTC Logic

INFOID:000000006147157

DTC DETECTION LOGIC

| DTC | Display item | Malfunction detected condition | Possible cause |
|-------|------------------|---|--|
| U1000 | CAN COMM CIRCUIT | When ABS actuator and electric unit (control unit) is not transmitting or receiving CAN communication signal for 2 seconds or more. | <ul style="list-style-type: none">• CAN communication line• ABS actuator and electric unit (control unit) |

BRC

Diagnosis Procedure

INFOID:000000006147158

1. CHECK CONNECTOR

1. Turn ignition switch OFF, disconnect the ABS actuator and electric unit (control unit) connector, and check the terminals for deformation, disconnection, looseness, and so on. If there is a malfunction, repair or replace the terminal.
2. Reconnect connector and perform self-diagnosis.

Is "CAN COMM CIRCUIT" displayed in self-diagnosis display items?

- YES >> Print out the self-diagnostic results, and refer to [LAN-14, "Trouble Diagnosis Flow Chart"](#).
- NO >> Connector terminal is loose, damaged, open, or shorted.

VDC OFF SWITCH

< DTC/CIRCUIT DIAGNOSIS >

[VDC/TCS/ABS]

VDC OFF SWITCH

Description

INFOID:000000006147159

VDC OFF switch can deactivate (turn OFF) the VDC/TCS function by pressing the VDC OFF switch.

Component Function Check

INFOID:000000006147160

1. CHECK VDC OFF SWITCH OPERATION

Turn ON/OFF the VDC OFF switch and check that the VDC OFF indicator lamp in the combination meter turns ON/OFF correctly.

| Condition | VDC OFF indicator lamp illumination status |
|---------------------|--|
| VDC OFF switch: ON | ON |
| VDC OFF switch: OFF | OFF |

Is the inspection result normal?

YES >> Inspection End

NO >> Go to diagnosis procedure. Refer to [BRC-78. "Diagnosis Procedure"](#).

Diagnosis Procedure

INFOID:000000006147161

Regarding Wiring Diagram information, refer to [BRC-92. "Wiring Diagram"](#).

1. CHECK VDC OFF SWITCH

Perform the VDC OFF switch component inspection. Refer to [BRC-79. "Component Inspection"](#).

Is the inspection result normal?

YES >> GO TO 2

NO >> Replace VDC OFF switch.

2. CHECK VDC OFF SWITCH HARNESS

1. Disconnect ABS actuator and electric unit (control unit) connector.
2. Check continuity between ABS actuator and electric unit (control unit) connector E125 (A) terminal 38 and VDC OFF switch connector M253 (B) terminal 1.

| ABS actuator and electric unit (control unit) | | VDC OFF switch | | Continuity |
|---|----------|----------------|----------|------------|
| Connector | Terminal | Connector | Terminal | |
| E125 (A) | 38 | M253 (B) | 1 | Yes |

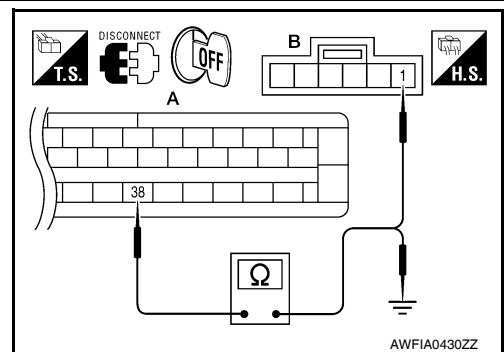

3. Check continuity between ABS actuator and electric unit (control unit) connector E125 (A) terminal 38 and ground.

| ABS actuator and electric unit (control unit) | | — | Continuity |
|---|----------|--------|------------|
| Connector | Terminal | | |
| E125 (A) | 38 | Ground | No |

Is the inspection result normal?

YES >> GO TO 3

NO >> Repair or replace harness.

3. CHECK VDC OFF SWITCH GROUND

VDC OFF SWITCH

[VDC/TCS/ABS]

< DTC/CIRCUIT DIAGNOSIS >

Check continuity between VDC OFF switch connector M253 terminal 2 and ground.

| VDC OFF switch | | — | Continuity |
|----------------|----------|--------|------------|
| Connector | Terminal | | |
| M253 | 2 | Ground | Yes |

Is the inspection result normal?

- YES >> GO TO 4
- NO >> Repair or replace harness.

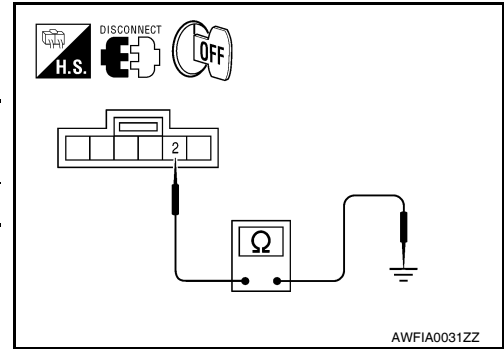

4.CHECK COMBINATION METER

Check if the indication and operation of combination meter are normal. Refer to [MWI-26, "Diagnosis Description"](#).

Is the inspection result normal?

- YES >> Replace ABS actuator and electric unit (control unit). Refer to [BRC-115, "Removal and Installation"](#).
- NO >> Replace combination meter. Refer to [MWI-97, "Removal and Installation"](#).

Component Inspection

INFOID:000000006147162

1.CHECK VDC OFF SWITCH

1. Turn ignition switch OFF.
2. Disconnect VDC OFF switch connector.
3. Check continuity between VDC OFF switch terminals.

| VDC OFF switch | Condition | Continuity |
|----------------|----------------------------------|------------|
| Terminal | | |
| 1 - 2 | When VDC OFF switch is pressed. | Yes |
| | When VDC OFF switch is released. | No |

Is the inspection result normal?

- YES >> Inspection End
- NO >> Replace VDC OFF switch.

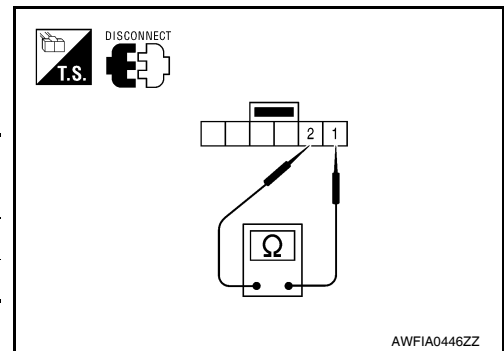

Special Repair Requirement

INFOID:000000006570237

1.ADJUSTMENT OF STEERING ANGLE SENSOR NEUTRAL POSITION

Always perform neutral position adjustment for the steering angle sensor when replacing the ABS actuator and electric unit (control unit). Refer to [BRC-8, "ADJUSTMENT OF STEERING ANGLE SENSOR NEUTRAL POSITION : Description"](#).

>> GO TO 2

2.CALIBRATION OF DECEL G SENSOR

Always perform calibration of decel G sensor when replacing the ABS actuator and electric unit (control unit). Refer to [BRC-9, "CALIBRATION OF DECEL G SENSOR : Description"](#).

>> END

ABS WARNING LAMP

< DTC/CIRCUIT DIAGNOSIS >

[VDC/TCS/ABS]

ABS WARNING LAMP

Description

INFOID:000000006147164

x: ON –: OFF

| Condition | ABS warning lamp |
|--|------------------|
| Ignition switch OFF | – |
| For 2 seconds after turning ON ignition switch | x |
| 2 seconds later after turning ON ignition switch | – |
| ABS function is malfunctioning. | x |
| EBD function is malfunctioning. | x |

Component Function Check

INFOID:000000006147165

1. CHECK ABS WARNING LAMP OPERATION

Check that the lamp illuminates for approximately 2 seconds after the ignition switch is turned ON.

Is the inspection result normal?

YES >> Inspection End

NO >> Go to diagnosis procedure. Refer to [BRC-80, "Diagnosis Procedure"](#).

Diagnosis Procedure

INFOID:000000006147166

1. CHECK SELF-DIAGNOSIS

Perform ABS actuator and electric unit (control unit) self-diagnosis. Refer to [BRC-24, "CONSULT-III Function \(ABS\)"](#).

Is the inspection result normal?

YES >> GO TO 2

NO >> Check items displayed by self-diagnosis.

2. CHECK COMBINATION METER

Check if the indication and operation of combination meter are normal. Refer to [MWI-26, "Diagnosis Description"](#).

Is the inspection result normal?

YES >> Replace ABS actuator and electric unit (control unit). Refer to [BRC-115, "Removal and Installation"](#).

NO >> Replace combination meter. Refer to [MWI-97, "Removal and Installation"](#).

Special Repair Requirement

INFOID:000000006570238

1. ADJUSTMENT OF STEERING ANGLE SENSOR NEUTRAL POSITION

Always perform neutral position adjustment for the steering angle sensor when replacing the ABS actuator and electric unit (control unit). Refer to [BRC-8, "ADJUSTMENT OF STEERING ANGLE SENSOR NEUTRAL POSITION : Description"](#).

>> GO TO 2

2. CALIBRATION OF DECEL G SENSOR

Always perform calibration of decel G sensor when replacing the ABS actuator and electric unit (control unit). Refer to [BRC-9, "CALIBRATION OF DECEL G SENSOR : Description"](#).

>> END

BRAKE WARNING LAMP

< DTC/CIRCUIT DIAGNOSIS >

[VDC/TCS/ABS]

BRAKE WARNING LAMP

Description

INFOID:000000006147168

x: ON –: OFF

| Condition | Brake warning lamp (Note 1) |
|---------------------------------|-----------------------------|
| Ignition switch OFF | – |
| Ignition switch ON | × (Note 2) |
| EBD function is malfunctioning. | × |

NOTE:

- 1: Brake warning lamp will turn on in case of parking brake operation (when switch is ON) or of brake fluid level switch operation (when brake fluid is insufficient).
- 2: After starting engine, brake warning lamp is turned off.

Component Function Check

INFOID:000000006147169

1. BRAKE WARNING LAMP OPERATION CHECK

Check that the lamp illuminates after the ignition switch is turned ON, and turns OFF after the engine is started.

Is the inspection result normal?

YES >> Inspection End

NO >> Go to diagnosis procedure. Refer to [BRC-81, "Diagnosis Procedure"](#).

Diagnosis Procedure

INFOID:000000006147170

1. CHECK SELF-DIAGNOSIS

Perform ABS actuator and electric unit (control unit) self-diagnosis. Refer to [BRC-24, "CONSULT-III Function \(ABS\)"](#).

Is the inspection result normal?

YES >> GO TO 2

NO >> Check items displayed by self-diagnosis.

2. CHECK COMBINATION METER

Check if the indication and operation of combination meter are normal. Refer to [MWI-26, "Diagnosis Description"](#).

Is the inspection result normal?

YES >> Replace ABS actuator and electric unit (control unit). Refer to [BRC-115, "Removal and Installation"](#).

NO >> Replace combination meter. Refer to [MWI-97, "Removal and Installation"](#).

Special Repair Requirement

INFOID:000000006570239

1. ADJUSTMENT OF STEERING ANGLE SENSOR NEUTRAL POSITION

Always perform neutral position adjustment for the steering angle sensor when replacing the ABS actuator and electric unit (control unit). Refer to [BRC-8, "ADJUSTMENT OF STEERING ANGLE SENSOR NEUTRAL POSITION : Description"](#).

>> GO TO 2

2. CALIBRATION OF DECEL G SENSOR

Always perform calibration of decel G sensor when replacing the ABS actuator and electric unit (control unit). Refer to [BRC-9, "CALIBRATION OF DECEL G SENSOR : Description"](#).

>> END

VDC OFF INDICATOR LAMP

< DTC/CIRCUIT DIAGNOSIS >

[VDC/TCS/ABS]

VDC OFF INDICATOR LAMP

Description

INFOID:000000006147172

x: ON - : OFF

| Condition | VDC OFF indicator lamp |
|--|------------------------|
| Ignition switch OFF | - |
| For 2 seconds after turning ON ignition switch | x |
| 2 seconds later after turning ON ignition switch | - |
| VDC OFF switch turned ON. (VDC function is OFF.) | x |
| VDC/TCS function is malfunctioning. | x |
| ABS function is malfunctioning. | x |
| EBD function is malfunctioning. | x |

Component Function Check

INFOID:000000006147173

1.VDC OFF INDICATOR LAMP OPERATION CHECK 1

Check that the lamp illuminates for approximately 2 seconds after the ignition switch is turned ON.

Is the inspection result normal?

YES >> GO TO 2

NO >> Go to diagnosis procedure. Refer to [BRC-82, "Diagnosis Procedure"](#).

2.VDC OFF INDICATOR LAMP OPERATION CHECK 2

Check that the VDC OFF indicator lamp in the combination meter turns ON/OFF correctly when operating the VDC OFF switch.

Is the inspection result normal?

YES >> Inspection End

NO >> Check VDC OFF switch. Refer to [BRC-78, "Diagnosis Procedure"](#).

Diagnosis Procedure

INFOID:000000006147174

1.CHECK VDC OFF SWITCH

Check that the VDC OFF indicator lamp in the combination meter turns ON/OFF correctly when operating the VDC OFF switch.

Is the inspection result normal?

YES >> GO TO 2

NO >> Check VDC OFF switch. Refer to [BRC-78, "Diagnosis Procedure"](#).

2.CHECK SELF-DIAGNOSIS

Perform ABS actuator and electric unit (control unit) self-diagnosis. Refer to [BRC-24, "CONSULT-III Function \(ABS\)"](#).

Is the inspection result normal?

YES >> GO TO 3

NO >> Check items displayed by self-diagnosis.

3.CHECK COMBINATION METER

Check if the indication and operation of combination meter are normal. Refer to [MWI-26, "Diagnosis Description"](#).

Is the inspection result normal?

YES >> Replace ABS actuator and electric unit (control unit). Refer to [BRC-115, "Removal and Installation"](#).

NO >> Replace combination meter. Refer to [MWI-97, "Removal and Installation"](#).

VDC OFF INDICATOR LAMP

< DTC/CIRCUIT DIAGNOSIS >

[VDC/TCS/ABS]

Special Repair Requirement

INFOID:000000006570240

1. ADJUSTMENT OF STEERING ANGLE SENSOR NEUTRAL POSITION

Always perform neutral position adjustment for the steering angle sensor when replacing the ABS actuator and electric unit (control unit). Refer to [BRC-8, "ADJUSTMENT OF STEERING ANGLE SENSOR NEUTRAL POSITION : Description"](#).

>> GO TO 2

2. CALIBRATION OF DECEL G SENSOR

Always perform calibration of decel G sensor when replacing the ABS actuator and electric unit (control unit). Refer to [BRC-9, "CALIBRATION OF DECEL G SENSOR : Description"](#).

>> END

A
B
C
D
E
G
H
I
J
K
L
M
N
O
P

BRC

SLIP INDICATOR LAMP

< DTC/CIRCUIT DIAGNOSIS >

[VDC/TCS/ABS]

SLIP INDICATOR LAMP

Description

INFOID:000000006147176

x: ON –: OFF

| Condition | SLIP indicator lamp |
|--|---------------------|
| Ignition switch OFF | – |
| For 2 seconds after turning ON ignition switch | x |
| 2 seconds later after turning ON ignition switch | – |
| VDC/TCS function is malfunctioning. | x |
| ABS function is malfunctioning. | x |
| EBD function is malfunctioning. | x |

Component Function Check

INFOID:000000006147177

1. CHECK SLIP INDICATOR LAMP OPERATION

Check that the lamp illuminates for approximately 2 seconds after the ignition switch is turned ON.

Is the inspection result normal?

YES >> Inspection End

NO >> Go to diagnosis procedure. Refer to [BRC-84. "Diagnosis Procedure"](#).

Diagnosis Procedure

INFOID:000000006147178

1. CHECK SELF-DIAGNOSIS

Perform ABS actuator and electric unit (control unit) self-diagnosis. Refer to [BRC-24. "CONSULT-III Function \(ABS\)"](#).

Is the inspection result normal?

YES >> GO TO 2

NO >> Check items displayed by self-diagnosis.

2. CHECK COMBINATION METER

Check if the indication and operation of combination meter are normal. Refer to [MWI-26. "Diagnosis Description"](#).

Is the inspection result normal?

YES >> Replace ABS actuator and electric unit (control unit). Refer to [BRC-115. "Removal and Installation"](#).

NO >> Replace combination meter. Refer to [MWI-97. "Removal and Installation"](#).

Special Repair Requirement

INFOID:000000006570241

1. ADJUSTMENT OF STEERING ANGLE SENSOR NEUTRAL POSITION

Always perform neutral position adjustment for the steering angle sensor when replacing the ABS actuator and electric unit (control unit). Refer to [BRC-8. "ADJUSTMENT OF STEERING ANGLE SENSOR NEUTRAL POSITION : Description"](#).

>> GO TO 2

2. CALIBRATION OF DECEL G SENSOR

Always perform calibration of decel G sensor when replacing the ABS actuator and electric unit (control unit). Refer to [BRC-9. "CALIBRATION OF DECEL G SENSOR : Description"](#).

>> END

ABS ACTUATOR AND ELECTRIC UNIT (CONTROL UNIT)

< ECU DIAGNOSIS INFORMATION >

[VDC/TCS/ABS]

ECU DIAGNOSIS INFORMATION

ABS ACTUATOR AND ELECTRIC UNIT (CONTROL UNIT)

Reference Value

INFOID:000000006147180

VALUES ON THE DIAGNOSIS TOOL

CAUTION:

The display shows the control unit calculation data, so a normal value might be displayed even in the event the output circuit (harness) is open or short-circuited.

CONSULT-III MONITOR ITEM

| Monitor item | Display content | Data monitor | |
|---------------|--|--|-------------------------------------|
| | | Condition | Reference value in normal operation |
| FR LH SENSOR | Wheel speed | 0 [km/h (MPH)] | Vehicle stopped |
| | | Nearly matches the speed meter display (± 10% or less) | Vehicle running (Note 1) |
| FR RH SENSOR | Wheel speed | 0 [km/h (MPH)] | Vehicle stopped |
| | | Nearly matches the speed meter display (± 10% or less) | Vehicle running (Note 1) |
| RR LH SENSOR | Wheel speed | 0 [km/h (MPH)] | Vehicle stopped |
| | | Nearly matches the speed meter display (± 10% or less) | Vehicle running (Note 1) |
| RR RH SENSOR | Wheel speed | 0 [km/h (MPH)] | Vehicle stopped |
| | | Nearly matches the speed meter display (± 10% or less) | Vehicle running (Note 1) |
| DECEL G-SEN | Longitudinal acceleration detected by Decel G-Sensor | Vehicle stopped | Approx. 0 G |
| | | Vehicle running | -1.7 to 1.7 G |
| FR RH IN SOL | Operation status of each solenoid valve | Actuator (solenoid valve) is active ("ACTIVE TEST" with CONSULT-III) or actuator relay is inactive (in fail-safe mode) | ON |
| | | When the actuator (solenoid valve) is not active and actuator relay is active (ignition switch ON) | OFF |
| FR RH OUT SOL | Operation status of each solenoid valve | Actuator (solenoid valve) is active ("ACTIVE TEST" with CONSULT-III) or actuator relay is inactive (in fail-safe mode) | ON |
| | | When the actuator (solenoid valve) is not active and actuator relay is active (ignition switch ON) | OFF |
| FR LH IN SOL | Operation status of each solenoid valve | Actuator (solenoid valve) is active ("ACTIVE TEST" with CONSULT-III) or actuator relay is inactive (in fail-safe mode) | ON |
| | | When the actuator (solenoid valve) is not active and actuator relay is active (ignition switch ON) | OFF |
| FR LH OUT SOL | Operation status of each solenoid valve | Actuator (solenoid valve) is active ("ACTIVE TEST" with CONSULT-III) or actuator relay is inactive (in fail-safe mode) | ON |
| | | When the actuator (solenoid valve) is not active and actuator relay is active (ignition switch ON) | OFF |

ABS ACTUATOR AND ELECTRIC UNIT (CONTROL UNIT)

< ECU DIAGNOSIS INFORMATION >

[VDC/TCS/ABS]

| Monitor item | Display content | Data monitor | |
|---------------|---|--|-------------------------------------|
| | | Condition | Reference value in normal operation |
| RR RH IN SOL | Operation status of each solenoid valve | Actuator (solenoid valve) is active ("ACTIVE TEST" with CONSULT-III) or actuator relay is inactive (in fail-safe mode) | ON |
| | | When the actuator (solenoid valve) is not active and actuator relay is active (ignition switch ON) | OFF |
| RR RH OUT SOL | Operation status of each solenoid valve | Actuator (solenoid valve) is active ("ACTIVE TEST" with CONSULT-III) or actuator relay is inactive (in fail-safe mode) | ON |
| | | When the actuator (solenoid valve) is not active and actuator relay is active (ignition switch ON) | OFF |
| RR LH IN SOL | Operation status of each solenoid valve | Actuator (solenoid valve) is active ("ACTIVE TEST" with CONSULT-III) or actuator relay is inactive (in fail-safe mode) | ON |
| | | When the actuator (solenoid valve) is not active and actuator relay is active (ignition switch ON) | OFF |
| RR LH OUT SOL | Operation status of each solenoid valve | Actuator (solenoid valve) is active ("ACTIVE TEST" with CONSULT-III) or actuator relay is inactive (in fail-safe mode) | ON |
| | | When the actuator (solenoid valve) is not active and actuator relay is active (ignition switch ON) | OFF |
| EBD WARN LAMP | EBD warning lamp (Note 2) | When EBD warning lamp is ON | ON |
| | | When EBD warning lamp is OFF | OFF |
| STOP LAMP SW | Stop lamp switch signal status | When brake pedal is depressed | ON |
| | | When brake pedal is released | OFF |
| MOTOR RELAY | Motor and motor relay operation | When the motor relay and motor are operating | ON |
| | | When the motor relay and motor are not operating | OFF |
| ACTUATOR RLY | Actuator relay operation | When the actuator relay is operating | ON |
| | | When the actuator relay is not operating | OFF |
| ABS WARN LAMP | ABS warning lamp (Note 2) | When ABS warning lamp is ON | ON |
| | | When ABS warning lamp is OFF | OFF |
| OFF LAMP | VDC OFF indicator lamp (Note 2) | When VDC OFF indicator lamp is ON | ON |
| | | When VDC OFF indicator lamp is OFF | OFF |
| OFF SW | VDC OFF switch ON/OFF | VDC OFF switch ON (When VDC OFF indicator lamp is ON) | ON |
| | | VDC OFF switch OFF (When VDC OFF indicator lamp is OFF) | OFF |
| SLIP LAMP | SLIP indicator lamp (Note 2) | When SLIP indicator lamp is ON | ON |
| | | When SLIP indicator lamp is OFF | OFF |
| BATTERY VOLT | Battery voltage supplied to the ABS actuator and electric unit (control unit) | Ignition switch ON | 10 – 16 V |
| GEAR | Gear position determined by TCM | 1st gear | 1 |
| | | 2nd gear | 2 |
| | | 3rd gear | 3 |
| | | 4th gear | 4 |
| | | 5th gear | 5 |

ABS ACTUATOR AND ELECTRIC UNIT (CONTROL UNIT)

< ECU DIAGNOSIS INFORMATION >

[VDC/TCS/ABS]

| Monitor item | Display content | Data monitor | |
|-----------------------|---|---|--|
| | | Condition | Reference value in normal operation |
| SLCT LVR POSI | A/T selector lever position | P position R position N position D position | P R N D |
| ENGINE SPEED | With engine running | With engine stopped | 0 rpm |
| | | Engine running | Almost in accordance with tachometer display |
| YAW RATE SEN | Yaw rate detected by yaw rate/side/decel G sensor | When vehicle is stopped | Approx. 0 d/s |
| | | When vehicle turning | -75 to 75 d/s |
| R POSI SIG | Transmission range switch signal ON/OFF condition | A/T shift position = R position | ON |
| | | A/T shift position = other than R position | OFF |
| 4WD FAIL REQ (Note 3) | Transfer control unit fail-safe signal | When transfer control unit is in fail-safe mode | ON |
| | | When transfer control unit is normal | OFF |
| N POSI SIG | Transmission range switch signal ON/OFF condition | A/T shift position = N position | ON |
| | | A/T shift position = other than N position | OFF |
| P POSI SIG | Transmission range switch signal ON/OFF condition | A/T shift position = P position | ON |
| | | A/T shift position = other than P position | OFF |
| CV1 | VDC switch-over valve | When actuator (switch-over valve) is active ("ACTIVE TEST" with CONSULT-III) or actuator relay is inactive (when in fail-safe mode) | ON |
| | | When actuator (switch-over valve) is not active and actuator relay is active (ignition switch ON) | OFF |
| CV2 | VDC switch-over valve | When actuator (switch-over valve) is active ("ACTIVE TEST" with CONSULT-III) or actuator relay is inactive (when in fail-safe mode) | ON |
| | | When actuator (switch-over valve) is not active and actuator relay is active (ignition switch ON) | OFF |
| SV1 | VDC switch-over valve | When actuator (switch-over valve) is active ("ACTIVE TEST" with CONSULT-III) or actuator relay is inactive (when in fail-safe mode) | ON |
| | | When actuator (switch-over valve) is not active and actuator relay is active (ignition switch ON) | OFF |
| SV2 | VDC switch-over valve | When actuator (switch-over valve) is active ("ACTIVE TEST" with CONSULT-III) or actuator relay is inactive (when in fail-safe mode) | ON |
| | | When actuator (switch-over valve) is not active and actuator relay is active (ignition switch ON) | OFF |
| 2WD/4WD | Drive axle | 2WD model | 2WD |
| | | 4WD model | 4WD |

A
B
C
D
E
BRC
G
H
I
J
K
L
M
N
O
P

ABS ACTUATOR AND ELECTRIC UNIT (CONTROL UNIT)

< ECU DIAGNOSIS INFORMATION >

[VDC/TCS/ABS]

| Monitor item | Display content | Data monitor | |
|---------------|--|--|-------------------------------------|
| | | Condition | Reference value in normal operation |
| ACCEL POS SIG | Throttle actuator opening/closing is displayed (linked with accelerator pedal) | Accelerator pedal not depressed (ignition switch is ON) | 0 % |
| | | Accelerator pedal depressed (ignition switch is ON) | 0 - 100 % |
| SIDE G-SENSOR | Transverse G detected by side G sensor | Vehicle stopped | Approx. 0 m/s ² |
| | | Vehicle turning right | Negative value (m/s ²) |
| | | Vehicle turning left | Positive value (m/s ²) |
| STR ANGLE SIG | Steering angle detected by steering angle sensor | Straight-ahead | Approx. 0±2.5° |
| | | Steering wheel turned | -720 to +720° |
| BST OPER SIG | Brake booster operation is displayed | Brake booster is active | ON |
| | | Brake booster is inactive | OFF |
| PRESS SENSOR | Brake fluid pressure detected by front pressure sensor | With ignition switch turned ON and brake pedal released | Approx. 0 bar |
| | | With ignition switch turned ON and brake pedal depressed | -40 to 300 bar |
| EBD SIGNAL | EBD operation | EBD is active | ON |
| | | EBD is inactive | OFF |
| ABS SIGNAL | ABS operation | ABS is active | ON |
| | | ABS is inactive | OFF |
| TCS SIGNAL | TCS operation | TCS is active | ON |
| | | TCS is inactive | OFF |
| VDC SIGNAL | VDC operation | VDC is active | ON |
| | | VDC is inactive | OFF |
| EBD FAIL SIG | EBD fail-safe signal | In EBD fail-safe | ON |
| | | EBD is normal | OFF |
| ABS FAIL SIG | ABS fail-safe signal | In ABS fail-safe | ON |
| | | ABS is normal | OFF |
| TCS FAIL SIG | TCS fail-safe signal | In TCS fail-safe | ON |
| | | TCS is normal | OFF |
| VDC FAIL SIG | VDC fail-safe signal | In VDC fail-safe | ON |
| | | VDC is normal | OFF |
| CRANKING SIG | Crank operation | Crank is active | ON |
| | | Crank is inactive | OFF |
| FLUID LEV SW | Brake fluid level switch signal status | When brake fluid level switch ON | ON |
| | | When brake fluid level switch OFF | OFF |
| PRESS SEN2 | Brake fluid pressure detected by rear pressure sensor | With ignition switch turned ON and brake pedal released | Approx. 0 bar |
| | | With ignition switch turned ON and brake pedal depressed | -40 to 300 bar |
| DELTA S SEN | Value detected by delta stroke sensor | When brake pedal is depressed | 1.05 - 1.80 mm |
| | | When brake pedal is released | 0.00 mm (+0.6/-0.4) |
| RELEASE SW NO | Active booster signal status | When brake pedal is depressed | ON |
| | | When brake pedal is released | OFF |

ABS ACTUATOR AND ELECTRIC UNIT (CONTROL UNIT)

< ECU DIAGNOSIS INFORMATION >

[VDC/TCS/ABS]

| Monitor item | Display content | Data monitor | |
|---------------|------------------------------|-------------------------------|-------------------------------------|
| | | Condition | Reference value in normal operation |
| RELEASE SW NC | Active booster signal status | When brake pedal is depressed | OFF |
| | | When brake pedal is released | ON |
| OHB FAIL | OHB fail safe signal | OHB is active | ON |
| | | OHB is inactive | OFF |
| HBA FAIL | HBA fail safe signal | HBA is active | ON |
| | | HBA is inactive | OFF |
| OHB SIG | OHB operation | In OHB fail-safe | ON |
| | | OHB is normal | OFF |
| HBA SIG | HBA operation | In HBA fail-safe | ON |
| | | HBA is normal | OFF |
| STP OFF RLY | Stop lamp relay signal | When stop lamp relay is ON | ON |
| | | When stop lamp relay is OFF | OFF |

NOTE:

- 1: Confirm tire pressure is normal.
- 2: On and off timing for warning lamp and indicator lamp.
- 3: Only 4WD models.
- ABS warning lamp: Refer to [BRC-80, "Description"](#).
- Brake warning lamp: Refer to [BRC-81, "Description"](#).
- VDC OFF indicator lamp: Refer to [BRC-82, "Description"](#).
- SLIP indicator lamp: Refer to [BRC-84, "Description"](#).

TERMINAL LAYOUT

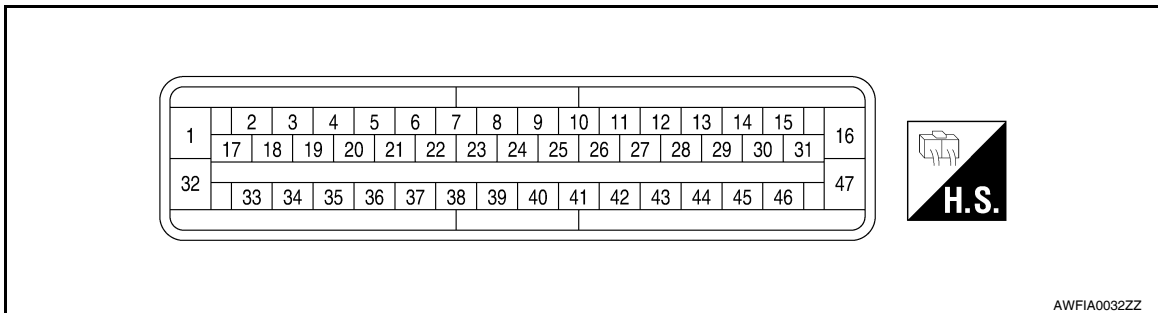

Fail-Safe

INFOID:000000006147182

CAUTION:

If the Fail-Safe function is activated, perform Self Diagnosis for ABS/TCS/VDC system.

ABS/EBD SYSTEM

In case of an electrical malfunction with the ABS, the ABS warning lamp, VDC OFF indicator lamp and SLIP indicator lamp will turn on. In case of an electrical malfunction with the EBD system, the BRAKE warning lamp, ABS warning lamp, VDC OFF indicator lamp and SLIP indicator lamp will turn on. The system will revert to one of the following conditions of the Fail-Safe function.

1. For ABS malfunction, only the EBD is operative and the condition of the vehicle is the same condition of vehicles without ABS/TCS/VDC system.
2. For EBD malfunction, the EBD and ABS become inoperative, and the condition of the vehicle is the same as the condition of vehicles without ABS/TCS/VDC or EBD system.

VDC/TCS SYSTEM

In case of TCS/VDC system malfunction, the VDC OFF indicator lamp and SLIP indicator lamp are turned on and the condition of the vehicle is the same as the condition of vehicles without TCS/VDC system. In case of an electrical malfunction with the TCS/VDC system, the ABS control continues to operate normally without TCS/VDC control.

ABS ACTUATOR AND ELECTRIC UNIT (CONTROL UNIT)

< ECU DIAGNOSIS INFORMATION >

[VDC/TCS/ABS]

DTC No. Index

INFOID:000000006147183

| DTC | Items (CONSULT screen terms) | Reference |
|-------|------------------------------|---------------------------------------|
| C1101 | RR RH SENSOR-1 | BRC-29, "Description" |
| C1102 | RR LH SENSOR-1 | |
| C1103 | FR RH SENSOR-1 | |
| C1104 | FR LH SENSOR-1 | |
| C1105 | RR RH SENSOR-2 | BRC-32, "Description" |
| C1106 | RR LH SENSOR-2 | |
| C1107 | FR RH SENSOR-2 | |
| C1108 | FR LH SENSOR-2 | |
| C1109 | BATTERY VOLTAGE [ABNORMAL] | BRC-35, "Description" |
| C1110 | CONTROLLER FAILURE | BRC-37, "DTC Logic" |
| C1111 | PUMP MOTOR | BRC-38, "Description" |
| C1113 | G-SENSOR | BRC-40, "Description" |
| C1115 | ABS SENSOR [ABNORMAL SIGNAL] | BRC-42, "Description" |
| C1116 | STOP LAMP SW | BRC-45, "Description" |
| C1120 | FR LH IN ABS SOL | BRC-47, "Description" |
| C1121 | FR LH OUT ABS SOL | BRC-50, "Description" |
| C1122 | FR RH IN ABS SOL | BRC-47, "Description" |
| C1123 | FR RH OUT ABS SOL | BRC-50, "Description" |
| C1124 | RR LH IN ABS SOL | BRC-47, "Description" |
| C1125 | RR LH OUT ABS SOL | BRC-50, "Description" |
| C1126 | RR RH IN ABS SOL | BRC-47, "Description" |
| C1127 | RR RH OUT ABS SOL | BRC-50, "Description" |
| C1130 | ENGINE SIGNAL 1 | BRC-53, "Description" |
| C1131 | ENGINE SIGNAL 2 | |
| C1132 | ENGINE SIGNAL 3 | |
| C1133 | ENGINE SIGNAL 4 | |
| C1136 | ENGINE SIGNAL 6 | |
| C1140 | ACTUATOR RLY | |
| C1142 | PRESS SEN CIRCUIT | BRC-57, "Description" |
| C1143 | ST ANG SEN CIRCUIT | BRC-60, "Description" |
| C1144 | ST ANG SEN SIGNAL | |
| C1145 | YAW RATE SENSOR | BRC-40, "Description" |
| C1146 | SIDE G-SEN CIRCUIT | |
| C1155 | BR FLUID LEVEL LOW | BRC-63, "Description" |
| C1156 | ST ANG SEN COM CIR | BRC-66, "Description" |
| C1160 | DECEL G SEN SET | BRC-67, "Description" |
| C1163 | ST ANGL SEN SAFE | BRC-68, "Description" |
| C1164 | CV1 | BRC-69, "Description" |
| C1165 | CV2 | |
| C1166 | SV1 | |
| C1167 | SV2 | |
| C1170 | VARIANT CODING | BRC-37, "DTC Logic" |

ABS ACTUATOR AND ELECTRIC UNIT (CONTROL UNIT)

< ECU DIAGNOSIS INFORMATION >

[VDC/TCS/ABS]

| DTC | Items (CONSULT screen terms) | Reference |
|-------|--------------------------------|---------------------------------------|
| C1178 | ABS ACTIVE BOOSTER SV NG | BRC-72. "Description" |
| C1179 | ABS DELTA S SEN NG | BRC-75. "Description" |
| C1181 | ABS ACTIVE BOOSTER RESPONSE NG | BRC-72. "Description" |
| C1184 | ABS BRAKE RELEASE SW NG | |
| C1189 | ABS BRAKE BOOSTER DEFECT | |
| U1000 | CAN COMM CIRCUIT | BRC-77. "Description" |

A
B
C
D
E
G
H
I
J
K
L
M
N
O
P

BRC

BRAKE CONTROL SYSTEM - VDC

[VDC/TCS/ABS]

< WIRING DIAGRAM >

WIRING DIAGRAM

BRAKE CONTROL SYSTEM - VDC

Wiring Diagram

INFOID:000000006418064

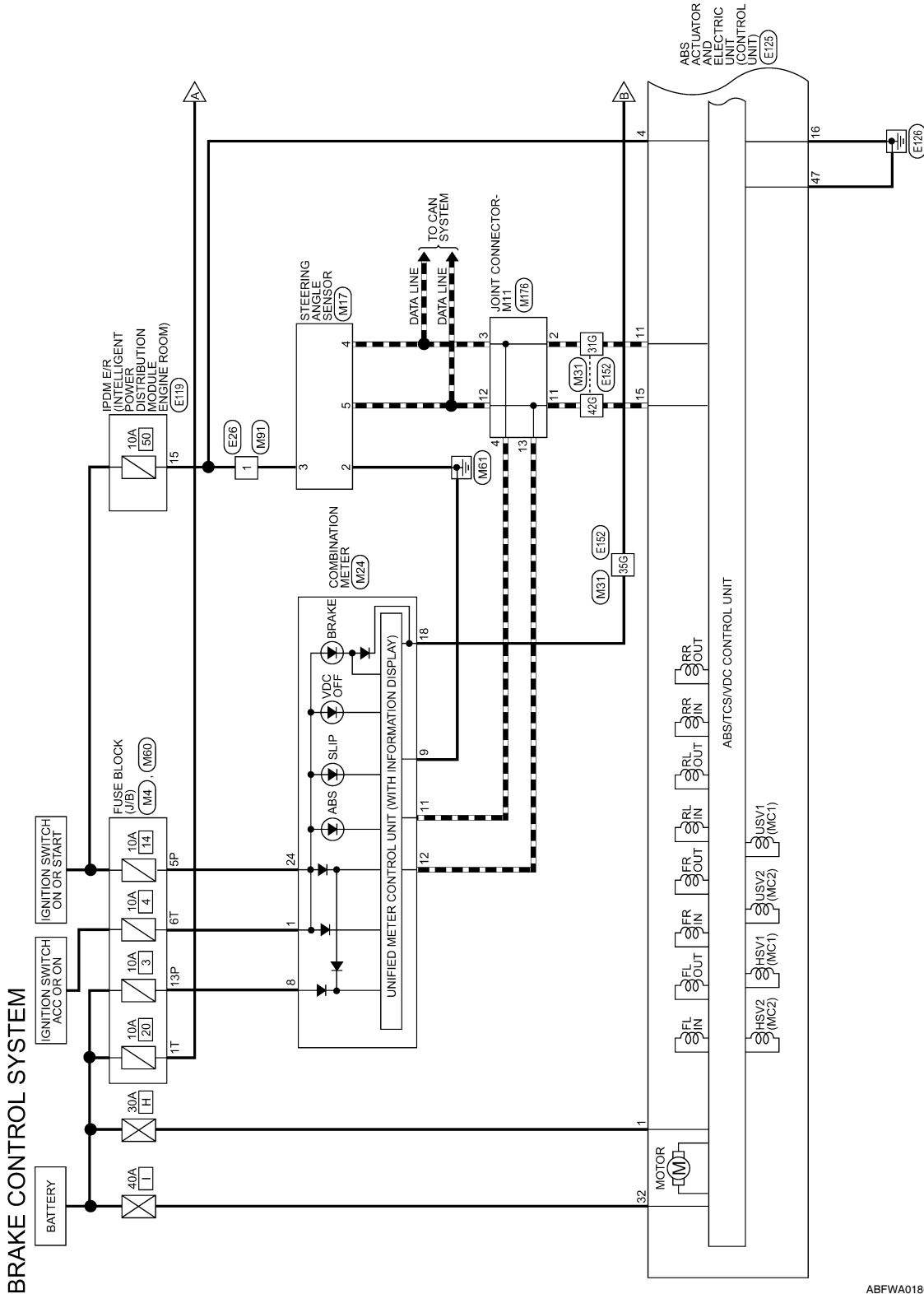

ABFWA0180GB

BRAKE CONTROL SYSTEM - VDC

< WIRING DIAGRAM >

[VDC/TCS/ABS]

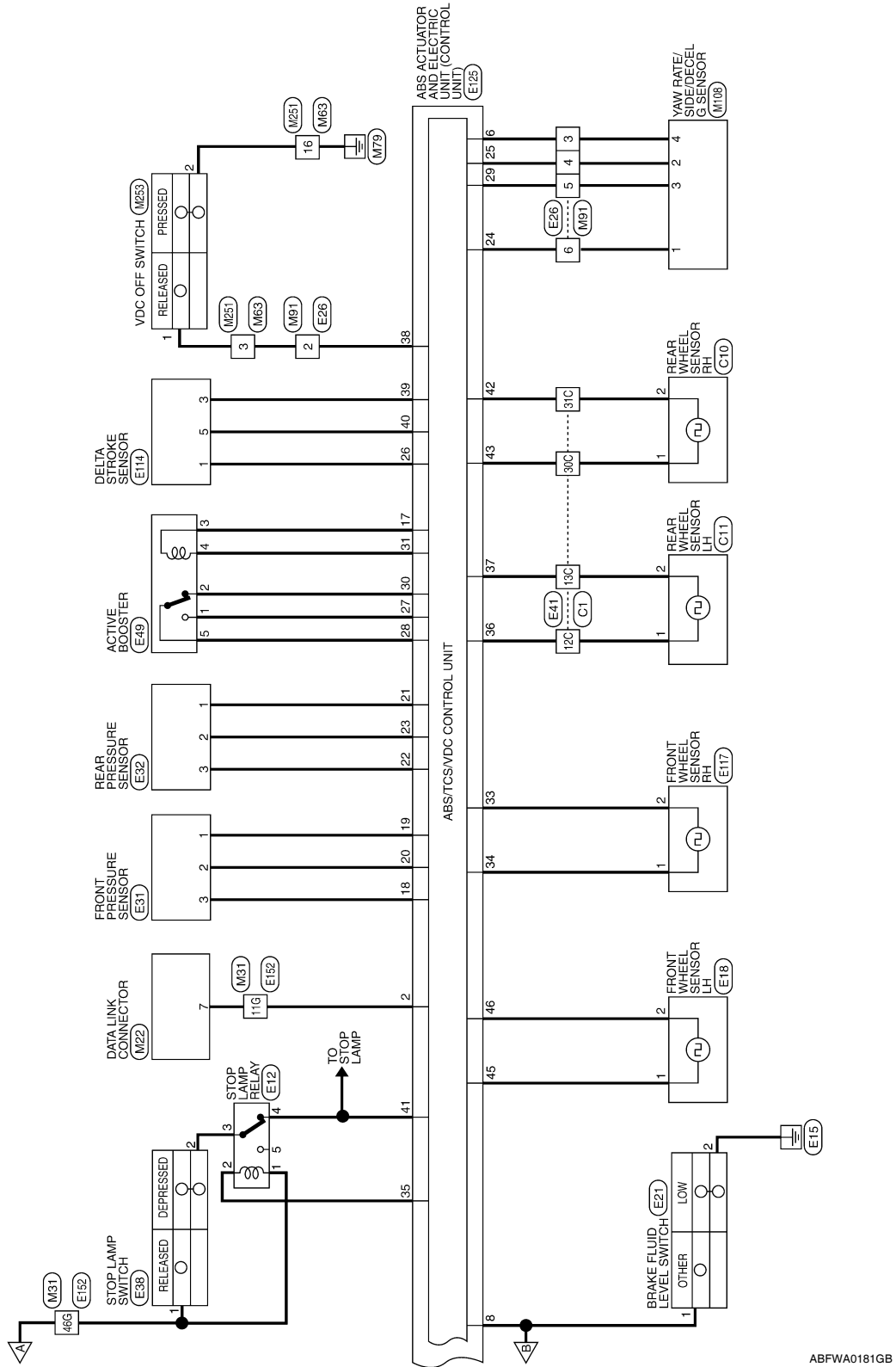

A
B
C
D
E
BRC
G
H
I
J
K
L
M
N
O
P

BRAKE CONTROL SYSTEM CONNECTORS

| | |
|-----------------|------------------|
| Connector No. | M4 |
| Connector Name | FUSE BLOCK (J/B) |
| Connector Color | WHITE |



| Terminal No. | Color of Wire | Signal Name |
|--------------|---------------|-------------|
| 5P | O/L | - |
| 13P | P | - |

| | |
|-----------------|-----------------------|
| Connector No. | M17 |
| Connector Name | STEERING ANGLE SENSOR |
| Connector Color | WHITE |

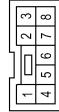

| Terminal No. | Color of Wire | Signal Name |
|--------------|---------------|-------------|
| 2 | B | GND |
| 3 | G/W | POWER |
| 4 | L | CAN-H |
| 5 | P | CAN-L |

| | |
|-----------------|---------------------|
| Connector No. | M22 |
| Connector Name | DATA LINK CONNECTOR |
| Connector Color | WHITE |

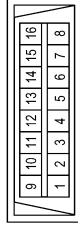

| Terminal No. | Color of Wire | Signal Name |
|--------------|---------------|-------------|
| 7 | G/W | - |

| | |
|-----------------|-------------------|
| Connector No. | M24 |
| Connector Name | COMBINATION METER |
| Connector Color | WHITE |

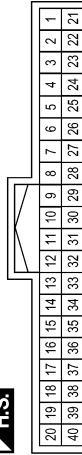

| Terminal No. | Color of Wire | Signal Name |
|--------------|---------------|-------------|
| 1 | O | ACCESSORY |
| 8 | P | BATTERY |
| 9 | B | GND |
| 11 | L | CAN-H |
| 12 | P | CAN-L |
| 18 | P/B | BRAKE FLUID |
| 24 | O/L | RUN/START |

| | |
|-----------------|--------------|
| Connector No. | M31 |
| Connector Name | WIRE TO WIRE |
| Connector Color | WHITE |

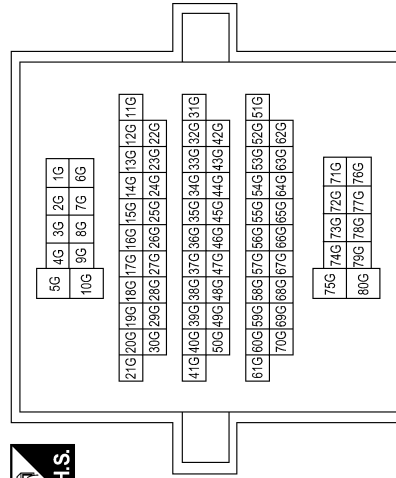

| Terminal No. | Color of Wire | Signal Name |
|--------------|---------------|-------------|
| 11G | G/W | - |
| 31G | L | - |
| 35G | P/B | - |
| 42G | P | - |
| 46G | R/Y | - |

BRAKE CONTROL SYSTEM - VDC

< WIRING DIAGRAM >

[VDC/TCS/ABS]

| | |
|-----------------|--------------|
| Connector No. | M91 |
| Connector Name | WIRE TO WIRE |
| Connector Color | WHITE |

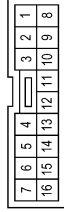

| Terminal No. | Color of Wire | Signal Name |
|--------------|---------------|-------------|
| 1 | GW | - |
| 2 | R/W | - |
| 3 | Y/R | - |
| 4 | G/R | - |
| 5 | GW | - |
| 6 | P | - |

| | |
|-----------------|--------------|
| Connector No. | M251 |
| Connector Name | WIRE TO WIRE |
| Connector Color | BROWN |

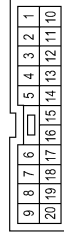

| Terminal No. | Color of Wire | Signal Name |
|--------------|---------------|-------------|
| 3 | R/W | - |
| 16 | B | - |

| | |
|-----------------|--------------|
| Connector No. | M63 |
| Connector Name | WIRE TO WIRE |
| Connector Color | BROWN |

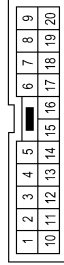

| Terminal No. | Color of Wire | Signal Name |
|--------------|---------------|-------------|
| 3 | R/W | - |
| 16 | B | - |

| | |
|-----------------|---------------------|
| Connector No. | M176 |
| Connector Name | JOINT CONNECTOR-M11 |
| Connector Color | BLUE |

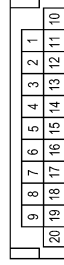

| Terminal No. | Color of Wire | Signal Name |
|--------------|---------------|-------------|
| 2 | L | - |
| 3 | L | - |
| 4 | L | - |
| 11 | P | - |
| 12 | P | - |
| 13 | P | - |

| | |
|-----------------|------------------|
| Connector No. | M60 |
| Connector Name | FUSE BLOCK (J/B) |
| Connector Color | WHITE |

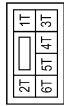

| Terminal No. | Color of Wire | Signal Name |
|--------------|---------------|-------------|
| 1T | R/Y | - |
| 6T | O | - |

| | |
|-----------------|------------------------------|
| Connector No. | M108 |
| Connector Name | YAW RATE/SIDE/DECEL G SENSOR |
| Connector Color | BLACK |

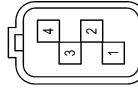

| Terminal No. | Color of Wire | Signal Name |
|--------------|---------------|-------------|
| 1 | P | CLU GND |
| 2 | G/R | CAN-H |
| 3 | G/W | CAN-L |
| 4 | Y/R | CLU P |

ABFIA0415GB

A
B
C
D
E
BRC
G
H
I
J
K
L
M
N
O
P

BRAKE CONTROL SYSTEM - VDC

< WIRING DIAGRAM >

[VDC/TCS/ABS]

| | |
|-----------------|--------------------------|
| Connector No. | E18 |
| Connector Name | FRONT WHEEL SENSOR LH |
| Connector Color | GRAY |



| Terminal No. | Color of Wire | Signal Name |
|--------------|---------------|-------------|
| 1 | G/O | - |
| 2 | BR/W | - |

| | |
|-----------------|-----------------|
| Connector No. | E12 |
| Connector Name | STOP LAMP RELAY |
| Connector Color | BLACK |



| Terminal No. | Color of Wire | Signal Name |
|--------------|---------------|-------------|
| 1 | R/Y | - |
| 2 | L/W | - |
| 3 | R/G | - |
| 4 | R/B | - |

| | |
|-----------------|----------------|
| Connector No. | M253 |
| Connector Name | VDC OFF SWITCH |
| Connector Color | GRAY |

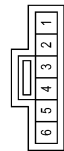

| Terminal No. | Color of Wire | Signal Name |
|--------------|---------------|-------------|
| 1 | R/W | - |
| 2 | B | - |

| | |
|-----------------|--------------------------|
| Connector No. | E31 |
| Connector Name | FRONT PRESSURE SENSOR |
| Connector Color | GRAY |

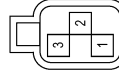

| Terminal No. | Color of Wire | Signal Name |
|--------------|---------------|-------------|
| 1 | SB | GND |
| 2 | R/L | SIG |
| 3 | LG | POWER |

| | |
|-----------------|--------------|
| Connector No. | E26 |
| Connector Name | WIRE TO WIRE |
| Connector Color | WHITE |

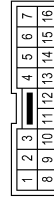

| Terminal No. | Color of Wire | Signal Name |
|--------------|---------------|-------------|
| 1 | LG/B | - |
| 2 | R/W | - |
| 3 | Y/R | - |
| 4 | G/R | - |
| 5 | G/W | - |
| 6 | P | - |

| | |
|-----------------|-----------------------------|
| Connector No. | E21 |
| Connector Name | BRAKE FLUID LEVEL SWITCH |
| Connector Color | GRAY |



| Terminal No. | Color of Wire | Signal Name |
|--------------|---------------|-------------|
| 1 | P/B | - |
| 2 | B | - |

ABFIA0416GB

BRAKE CONTROL SYSTEM - VDC

< WIRING DIAGRAM >

[VDC/TCS/ABS]

| | |
|-----------------|------------------|
| Connector No. | E38 |
| Connector Name | STOP LAMP SWITCH |
| Connector Color | BLACK |



| Terminal No. | Color of Wire | Signal Name |
|--------------|---------------|-------------|
| 1 | R/Y | - |
| 2 | R/G | - |

| | |
|-----------------|----------------------|
| Connector No. | E32 |
| Connector Name | REAR PRESSURE SENSOR |
| Connector Color | GRAY |

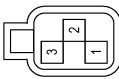

| Terminal No. | Color of Wire | Signal Name |
|--------------|---------------|-------------|
| 1 | R/G | GND |
| 2 | W/O | SIG |
| 3 | W/L | POWER |

| | |
|-----------------|----------------|
| Connector No. | E49 |
| Connector Name | ACTIVE BOOSTER |
| Connector Color | BLACK |

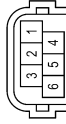

| Terminal No. | Color of Wire | Signal Name |
|--------------|---------------|-------------|
| 1 | L/B | - |
| 2 | LG/R | - |
| 3 | W/R | - |
| 4 | W/G | - |
| 5 | Y/B | - |

| Terminal No. | Color of Wire | Signal Name |
|--------------|---------------|-------------|
| 12C | L | - |
| 13C | P | - |
| 30C | G/Y | - |
| 31C | V | - |

| | |
|-----------------|--------------|
| Connector No. | E41 |
| Connector Name | WIRE TO WIRE |
| Connector Color | GRAY |

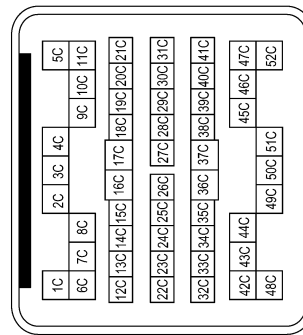

ABFIA0417GB

A
B
C
D
E
BRC
G
H
I
J
K
L
M
N
O
P

BRAKE CONTROL SYSTEM - VDC

< WIRING DIAGRAM >

[VDC/TCS/ABS]

| | |
|-----------------|--|
| Connector No. | E119 |
| Connector Name | IPDM E/R (INTELLIGENT POWER DISTRIBUTION MODULE ENGINE ROOM) |
| Connector Color | WHITE |

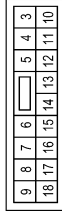

| Terminal No. | Color of Wire | Signal Name |
|--------------|---------------|----------------|
| 15 | LG/B | ABS IGN SUPPLY |

| | |
|-----------------|-----------------------|
| Connector No. | E117 |
| Connector Name | FRONT WHEEL SENSOR RH |
| Connector Color | GRAY |



| Terminal No. | Color of Wire | Signal Name |
|--------------|---------------|-------------|
| 1 | B/R | - |
| 2 | BR | - |

| | |
|-----------------|---------------------|
| Connector No. | E114 |
| Connector Name | DELTA STROKE SENSOR |
| Connector Color | BLACK |

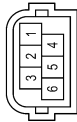

| Terminal No. | Color of Wire | Signal Name |
|--------------|---------------|-------------|
| 1 | W/W | DELS PWR |
| 3 | G/B | DELS GND |
| 5 | R/Y | DELS SIG |

ABFIA0418GB

BRAKE CONTROL SYSTEM - VDC

< WIRING DIAGRAM >

[VDC/TCS/ABS]

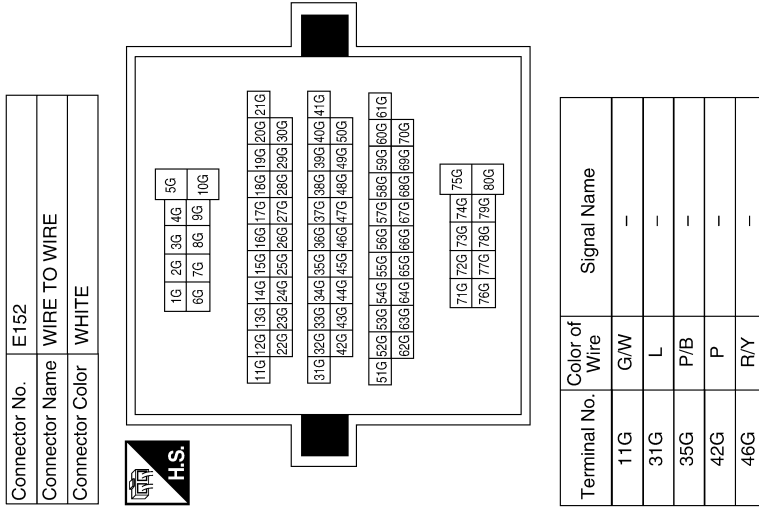

| Terminal No. | Color of Wire | Signal Name |
|--------------|---------------|------------------|
| 19 | SB | PS1 GND |
| 20 | R/L | PS1 SIGNAL |
| 21 | R/G | PS2 GND |
| 22 | W/L | PS2 SUPPLY |
| 23 | W/O | PS2 SIGNAL |
| 24 | P | CLUSTER GND |
| 25 | G/R | CAN2 L |
| 26 | W/V | DEL S SUPPLY |
| 27 | L/B | BST NO |
| 28 | Y/B | BST SIG |
| 29 | G/W | CAN2 H |
| 30 | LG/R | BST NC |
| 31 | W/G | BST GND |
| 32 | B/Y | VALVE ECU SUPPLY |
| 33 | BR | WSS FR SIG |
| 34 | B/R | WSS FR PWR |
| 35 | L/W | BRL OUT |
| 36 | L | WSS RL PWR |
| 37 | P | WSS RL SIG |
| 38 | R/W | VDC OFF SW |
| 39 | G/B | DEL S GND |
| 40 | R/Y | DEL-S SIGNAL |
| 41 | R/B | BLS |
| 42 | V | WSS RR SIG |
| 43 | G/Y | WSS RR PWR |
| 44 | - | - |
| 45 | G/O | WSS FL PWR |
| 46 | BR/W | WSS FL SIG |
| 47 | B | MOTOR GND |

| | |
|-----------------|---|
| Connector No. | E125 |
| Connector Name | ABS ACTUATOR AND ELECTRIC UNIT (CONTROL UNIT) |
| Connector Color | BLACK |

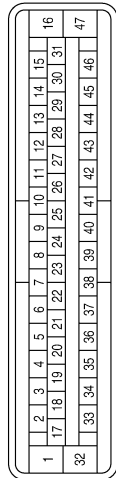

| Terminal No. | Color of Wire | Signal Name |
|--------------|---------------|----------------|
| 1 | Y | MOTOR SUPPLY |
| 2 | G/W | DIAG K |
| 3 | - | - |
| 4 | LG/B | IGN |
| 5 | - | - |
| 6 | Y/R | CLUSTER SUPPLY |
| 7 | - | - |
| 8 | P/B | FLUID LEVEL SW |
| 9 | - | - |
| 10 | - | - |
| 11 | L | CAN-H |
| 12 | - | - |
| 13 | - | - |
| 14 | - | - |
| 15 | P | CAN-L |
| 16 | B | VALVE ECU GND |
| 17 | W/R | BST SUPPLY |
| 18 | LG | PS1 SUPPLY |

ABFIA0419GB

A
B
C
D
E
F
G
H
I
J
K
L
M
N
O
P

BRC

BRAKE CONTROL SYSTEM - VDC

< WIRING DIAGRAM >

[VDC/TCS/ABS]

| | |
|-----------------|----------------------|
| Connector No. | C11 |
| Connector Name | REAR WHEEL SENSOR LH |
| Connector Color | BROWN |



| Terminal No. | Color of Wire | Signal Name |
|--------------|---------------|-------------|
| 1 | L | - |
| 2 | P | - |

| | |
|-----------------|----------------------|
| Connector No. | C10 |
| Connector Name | REAR WHEEL SENSOR RH |
| Connector Color | BROWN |



| Terminal No. | Color of Wire | Signal Name |
|--------------|---------------|-------------|
| 1 | G/Y | - |
| 2 | V | - |

| | |
|-----------------|--------------|
| Connector No. | C1 |
| Connector Name | WIRE TO WIRE |
| Connector Color | GRAY |

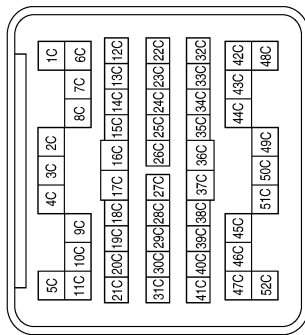

| Terminal No. | Color of Wire | Signal Name |
|--------------|---------------|-------------|
| 12C | L | - |
| 13C | P | - |
| 30C | G/Y | - |
| 31C | V | - |

SYMPTOM DIAGNOSIS

VDC/TCS/ABS

Symptom Table

INFOID:000000006147184

If ABS warning lamp, VDC OFF indicator lamp and SLIP indicator lamp turn ON, perform self-diagnosis.

| Symptom | Check item | Reference |
|--|--|--|
| Excessive ABS function operation frequency | Brake force distribution | BRC-102. "Diagnosis Procedure" |
| | Looseness of front and rear axle | |
| | Wheel sensor and rotor system | |
| Unexpected pedal reaction | Brake pedal stroke | BRC-103. "Diagnosis Procedure" |
| | Make sure the braking force is sufficient when the ABS is not operating. | |
| The braking distance is long | Check stopping distance when the ABS is not operating. | BRC-104. "Diagnosis Procedure" |
| ABS function does not operate (Note 1) | ABS actuator and electric unit (control unit) | BRC-105. "Diagnosis Procedure" |
| Pedal vibration or ABS operation sound occurs (Note 2) | Brake pedal | BRC-106. "Diagnosis Procedure" |
| | ABS actuator and electric unit (control unit) | |
| Vehicle jerks during VDC/TCS/ABS control | ABS actuator and electric unit (control unit) | BRC-107. "Diagnosis Procedure" |
| | TCM | |
| | ECM | |

NOTE:

- 1: The ABS does not operate when the speed is 10 km/h (6 MPH) or less.
- 2: Under the following conditions, ABS is activated and vibration is felt when brake pedal is lightly depressed. However, this is normal.
 - When shifting gears
 - When driving on slippery road
 - During cornering at high speed
 - When passing over bumps or grooves [at approximately 50 mm (1.97 in) or more]
 - When pulling away just after starting engine [at approximately 10 km/h (6 MPH) or higher]

EXCESSIVE ABS FUNCTION OPERATION FREQUENCY

< SYMPTOM DIAGNOSIS >

[VDC/TCS/ABS]

EXCESSIVE ABS FUNCTION OPERATION FREQUENCY

Diagnosis Procedure

INFOID:000000006147185

1.CHECK BRAKE FORCE

Check front and rear brake force distribution using a brake tester.

Is the inspection result normal?

YES >> GO TO 2

NO >> Check brake system.

2.CHECK FRONT AND REAR AXLE

Make sure that there is no excessive play in the front and rear axles. Refer to front: [FAX-6. "On-Vehicle Inspection and Service"](#), Rear: [RAX-6. "On-Vehicle Inspection and Service"](#).

Is the inspection result normal?

YES >> GO TO 3

NO >> Repair or replace malfunctioning components.

3.CHECK WHEEL SENSOR AND SENSOR ROTOR

Check the following.

- Wheel sensor installation for damage.
- Sensor rotor installation for damage.
- Wheel sensor connector connection.
- Wheel sensor harness inspection.

Is the inspection result normal?

YES >> GO TO 4

NO >> • Replace wheel sensor or sensor rotor. Refer to [BRC-113. "Removal and Installation"](#).
• Repair harness.

4.CHECK ABS WARNING LAMP DISPLAY

Make sure that the ABS warning lamp is turned off after the ignition switch is turned ON or when driving.

Is the ABS warning lamp illuminated?

YES >> Perform self-diagnosis. Refer to [BRC-24. "CONSULT-III Function \(ABS\)"](#).

NO >> Inspection End.

UNEXPECTED PEDAL REACTION

< SYMPTOM DIAGNOSIS >

[VDC/TCS/ABS]

UNEXPECTED PEDAL REACTION

Diagnosis Procedure

INFOID:000000006147186

1.CHECK BRAKE PEDAL STROKE

Check brake pedal stroke. Refer to [BR-15, "Inspection and Adjustment"](#).

Is the stroke too large?

- YES >> • Bleed air from brake tube and hose. Refer to [BR-17, "Bleeding Brake System"](#).
• Check brake pedal, brake booster, and master cylinder for mount play, looseness, brake system fluid leakage, etc. Refer to [BR-15, "Inspection and Adjustment"](#) (brake pedal), [BR-12, "On Board Inspection"](#) (master cylinder), [BR-10, "Inspection"](#) (brake booster).

NO >> GO TO 2

2.CHECK ABS FUNCTION

Disconnect ABS actuator and electric unit (control unit) connector to deactivate ABS. Check if braking force is normal in this condition. Connect connector after inspection.

Is the inspection result normal?

- YES >> Inspection End.
NO >> Check brake system.

A
B
C
D
E
F
G
H
I
J
K
L
M
N
O
P

BRC

THE BRAKING DISTANCE IS LONG

< SYMPTOM DIAGNOSIS >

[VDC/TCS/ABS]

THE BRAKING DISTANCE IS LONG

Diagnosis Procedure

INFOID:000000006147187

CAUTION:

The stopping distance on slippery road surfaces might be longer with the ABS operating than when the ABS is not operating.

1.CHECK ABS FUNCTION

Turn ignition switch OFF and disconnect ABS actuator and electric unit (control unit) connector to deactivate ABS. In this condition, check stopping distance. After inspection, connect connector.

Is the inspection result normal?

- YES >> Inspection End.
- NO >> Check brake system.

ABS FUNCTION DOES NOT OPERATE

< SYMPTOM DIAGNOSIS >

[VDC/TCS/ABS]

ABS FUNCTION DOES NOT OPERATE

Diagnosis Procedure

INFOID:000000006147188

CAUTION:

ABS does not operate when speed is 10 km/h (6 MPH) or lower.

1.CHECK ABS WARNING LAMP DISPLAY

Make sure that the ABS warning lamp turns OFF after ignition switch is turned ON or when driving.

Is the inspection result normal?

YES >> Inspection End.

NO >> Perform self-diagnosis. Refer to [BRC-24, "CONSULT-III Function \(ABS\)"](#).

A
B
C
D
E
G
H
I
J
K
L
M
N
O
P

BRC

PEDAL VIBRATION OR ABS OPERATION SOUND OCCURS

< SYMPTOM DIAGNOSIS >

[VDC/TCS/ABS]

PEDAL VIBRATION OR ABS OPERATION SOUND OCCURS

Diagnosis Procedure

INFOID:000000006147189

CAUTION:

Under the following conditions, ABS is activated and vibration is felt when brake pedal is lightly depressed. However, this is normal.

- When shifting gears
- When driving on slippery road
- During cornering at high speed
- When passing over bumps or grooves [at approximately 50 mm (1.97 in) or more]
- When pulling away just after starting engine [at approximately 10 km/h (6 MPH) or higher]

1. SYMPTOM CHECK 1

Check that there are pedal vibrations when the engine is started.

Do vibrations occur?

- YES >> GO TO 2
NO >> Inspect the brake pedal.

2. SYMPTOM CHECK 2

Check that there are ABS operation noises when the engine is started.

Do the operation noises occur?

- YES >> GO TO 3
NO >> Perform self -diagnosis. Refer to [BRC-24, "CONSULT-III Function \(ABS\)"](#).

3. SYMPTOM CHECK 3

Check symptoms when electrical component (headlamps, etc.) switches are operated.

Do symptoms occur?

- YES >> Check if there is a radio, antenna, antenna lead wire, or wiring close to the control unit. If there is, move it farther away.
NO >> Inspection End.

VEHICLE JERKS DURING VDC/TCS/ABS CONTROL

< SYMPTOM DIAGNOSIS >

[VDC/TCS/ABS]

VEHICLE JERKS DURING VDC/TCS/ABS CONTROL

Diagnosis Procedure

INFOID:000000006147190

1. SYMPTOM CHECK

Check if the vehicle jerks during VDC/TCS/ABS control.

Is the inspection result normal?

- YES >> Inspection End.
- NO >> GO TO 2

2. CHECK SELF-DIAGNOSIS RESULTS

Perform self-diagnosis of ABS actuator and electric unit (control unit). Refer to [BRC-24. "CONSULT-III Function \(ABS\)"](#).

Are self-diagnosis results indicated?

- YES >> Check corresponding items, make repairs, and perform ABS actuator and electric unit (control unit) self-diagnosis.
- NO >> GO TO 3

3. CONNECTOR INSPECTION

- Turn ignition switch OFF and disconnect ABS actuator and electric unit (control unit) connector and check terminal for deformation, disconnection, looseness, etc.
- Securely connect connectors and perform ABS actuator and electric unit (control unit) self-diagnosis. Refer to [BRC-24. "CONSULT-III Function \(ABS\)"](#).

Are self-diagnosis results indicated?

- YES >> If poor contact, damage, open or short circuit of connector terminal is found, repair or replace.
- NO >> GO TO 4

4. CHECK ECM AND TCM SELF-DIAGNOSIS RESULTS

Perform ECM and TCM self-diagnosis.

Are self-diagnosis results indicated?

- YES >> Check the corresponding items.
 - ECM: Refer to [EC-50. "CONSULT-III Function"](#).
 - TCM: Refer to [TM-32. "CONSULT-III Function \(TRANSMISSION\)"](#).
- NO >> Replace ABS actuator and electric unit (control unit). Refer to [BRC-115. "Removal and Installation"](#).

NORMAL OPERATING CONDITION

< SYMPTOM DIAGNOSIS >

[VDC/TCS/ABS]

NORMAL OPERATING CONDITION

Description

INFOID:000000006147191

| Symptom | Result |
|--|---|
| Slight vibrations are felt on the brake pedal and the operation noises occur, when VDC, TCS or ABS is activated. | This is a normal condition due to the VDC, TCS or ABS activation. |
| Stopping distance is longer than that of vehicles without ABS when the vehicle drives on rough, gravel, or snow-covered (fresh, deep snow) roads. | |
| The brake pedal moves and generates noises, when TCS or VDC is activated due to rapid acceleration or sharp turn. | |
| The brake pedal vibrates and motor operation noises occur from the engine room, after the engine starts and just after the vehicle starts. | This is normal, and it is caused by the ABS operation check. |
| Depending on the road conditions, the driver may experience a sluggish feel. | This is normal, because TCS places the highest priority on the optimum traction (stability). |
| TCS may activate momentarily if wheel speed changes when driving over location where friction coefficient varies, when downshifting, or when fully depressing accelerator pedal. | |
| The ABS warning lamp, VDC OFF indicator lamp and SLIP indicator lamp may turn ON when the vehicle is subject to strong shaking or large vibration, such as when the vehicle is rotating on a turntable or located on a ship while the engine is running. | In this case, restart the engine on a normal road. If the normal condition is restored, there is no malfunction. At that time, erase the self-diagnosis memory. |
| VDC may not operate normally or the ABS warning lamp, VDC OFF indicator lamp, and SLIP indicator lamp may illuminate, when running on a special road that is extremely slanted (e.g. bank in a circuit course). | |
| A malfunction may occur in the yaw rate/side/decel G sensor system, when the vehicle turns sharply, such as during a spin turn, axle turn, or drift driving, while the VDC function is off (VDC OFF indicator lamp illuminated). | |
| The vehicle speed will not increase even though the accelerator pedal is depressed, when inspecting the speedometer on a 2-wheel chassis dynamometer. | Normal (Deactivate the VDC/TCS function before performing an inspection on a chassis dynamometer.) |
| VDC OFF indicator lamp and SLIP indicator lamp may simultaneously turn on when low tire pressure warning lamp turns on. | This is not a VDC system error but results from characteristic change of tire. |

PRECAUTION

PRECAUTIONS

Precaution for Supplemental Restraint System (SRS) "AIR BAG" and "SEAT BELT PRE-TENSIONER"

INFOID:000000006147192

The Supplemental Restraint System such as "AIR BAG" and "SEAT BELT PRE-TENSIONER", used along with a front seat belt, helps to reduce the risk or severity of injury to the driver and front passenger for certain types of collision. This system includes seat belt switch inputs and dual stage front air bag modules. The SRS system uses the seat belt switches to determine the front air bag deployment, and may only deploy one front air bag, depending on the severity of a collision and whether the front occupants are belted or unbelted. Information necessary to service the system safely is included in the SR and SB section of this Service Manual.

WARNING:

- To avoid rendering the SRS inoperative, which could increase the risk of personal injury or death in the event of a collision which would result in air bag inflation, all maintenance must be performed by an authorized NISSAN/INFINITI dealer.
- Improper maintenance, including incorrect removal and installation of the SRS, can lead to personal injury caused by unintentional activation of the system. For removal of Spiral Cable and Air Bag Module, see the SR section.
- Do not use electrical test equipment on any circuit related to the SRS unless instructed to in this Service Manual. SRS wiring harnesses can be identified by yellow and/or orange harnesses or harness connectors.

PRECAUTIONS WHEN USING POWER TOOLS (AIR OR ELECTRIC) AND HAMMERS

WARNING:

- When working near the Airbag Diagnosis Sensor Unit or other Airbag System sensors with the Ignition ON or engine running, DO NOT use air or electric power tools or strike near the sensor(s) with a hammer. Heavy vibration could activate the sensor(s) and deploy the air bag(s), possibly causing serious injury.
- When using air or electric power tools or hammers, always switch the Ignition OFF, disconnect the battery, and wait at least 3 minutes before performing any service.

Precaution Necessary for Steering Wheel Rotation After Battery Disconnect

INFOID:000000006147193

NOTE:

- This Procedure is applied only to models with Intelligent Key system and NATS (NISSAN ANTI-THEFT SYSTEM).
- Remove and install all control units after disconnecting both battery cables with the ignition knob in the "LOCK" position.
- Always use CONSULT-III to perform self-diagnosis as a part of each function inspection after finishing work. If DTC is detected, perform trouble diagnosis according to self-diagnostic results.

For models equipped with the Intelligent Key system and NATS, an electrically controlled steering lock mechanism is adopted on the key cylinder.

For this reason, if the battery is disconnected or if the battery is discharged, the steering wheel will lock and steering wheel rotation will become impossible.

If steering wheel rotation is required when battery power is interrupted, follow the procedure below before starting the repair operation.

OPERATION PROCEDURE

1. Connect both battery cables.

NOTE:

Supply power using jumper cables if battery is discharged.

2. Use the Intelligent Key or mechanical key to turn the ignition switch to the "ACC" position. At this time, the steering lock will be released.
3. Disconnect both battery cables. The steering lock will remain released and the steering wheel can be rotated.
4. Perform the necessary repair operation.

A
B
C
D
E
BRC
G
H
I
J
K
L
M
N
O
P

PRECAUTIONS

[VDC/TCS/ABS]

< PRECAUTION >

5. When the repair work is completed, return the ignition switch to the "LOCK" position before connecting the battery cables. (At this time, the steering lock mechanism will engage.)
6. Perform a self-diagnosis check of all control units using CONSULT-III.

Precaution for Brake System

INFOID:000000006147194

CAUTION:

- Always use recommended brake fluid. Refer to [MA-21, "FOR USA AND CANADA : Fluids and Lubricants"](#).
- Never reuse drained brake fluid.
- Be careful not to splash brake fluid on painted areas; it may cause paint damage. If brake fluid is splashed on painted areas, wash it away with water immediately.
- To clean or wash all parts of master cylinder and disc brake caliper, use clean brake fluid.
- Never use mineral oils such as gasoline or kerosene. They will ruin rubber parts of the hydraulic system.
- Use flare nut wrench when removing and installing brake tube.
- If a brake fluid leak is found, the part must be disassembled without fail. Then it has to be replaced with a new one if a defect exists.
- Turn the ignition switch OFF and remove the connector of the ABS actuator and electric unit (control unit) or the battery terminal before performing the work.
- Always torque brake lines when installing.
- Burnish the brake contact surfaces after refinishing or replacing rotors, after replacing pads, or if a soft pedal occurs at very low mileage.
Refer to [BR-31, "Brake Burnishing Procedure"](#) (front disc brake) or [BR-36, "Brake Burnishing Procedure"](#) (rear disc brake).

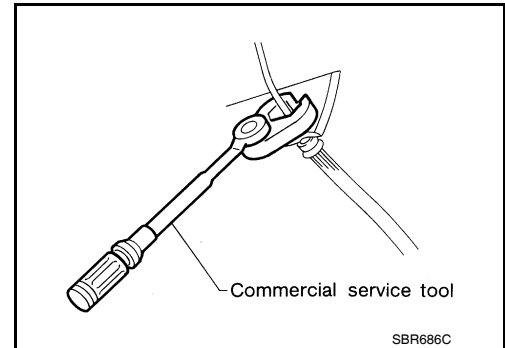

WARNING:

- Clean brake pads and shoes with a waste cloth, then wipe with a dust collector.

Precaution for Brake Control

INFOID:000000006147195

- During ABS operation, the brake pedal may vibrate lightly and a mechanical noise may be heard. This is normal.
- Just after starting vehicle, the brake pedal may vibrate or a motor operating noise may be heard from engine compartment. This is a normal status of operation check.
- Stopping distance may be longer than that of vehicles without ABS when vehicle drives on rough, gravel, or snow-covered (fresh, deep snow) roads.
- When an error is indicated by ABS or another warning lamp, collect all necessary information from customer (what symptoms are present under what conditions) and check for simple causes before starting diagnosis. Besides electrical system inspection, check booster operation, brake fluid level, and fluid leaks.
- If incorrect tire sizes or types are installed on the vehicle or brake pads are not Genuine NISSAN parts, stopping distance or steering stability may deteriorate.
- If there is a radio, antenna or related wiring near control module, ABS function may have a malfunction or error.
- If aftermarket parts (car stereo, CD player, etc.) have been installed, check for incidents such as harness pinches, open circuits or improper wiring.
- If the following components are replaced with non-genuine components or modified, the VDC OFF indicator lamp and SLIP indicator lamp may turn on or the VDC system may not operate properly. Components related to suspension (shock absorbers, struts, springs, bushings, etc.), tires, wheels (exclude specified size), components related to brake system (pads, rotors, calipers, etc.), components related to engine (muffler, ECM, etc.), components related to body reinforcement (roll bar, tower bar, etc.).
- Driving with broken or excessively worn suspension components, tires or brake system components may cause the VDC OFF indicator lamp and the SLIP indicator lamp to turn on, and the VDC system may not operate properly.
- When the TCS or VDC is activated by sudden acceleration or sudden turn, some noise may occur. The noise is a result of the normal operation of the TCS and VDC.

PRECAUTIONS

[VDC/TCS/ABS]

< PRECAUTION >

- When driving on roads which have extreme slopes (such as mountainous roads) or high banks (such as sharp curves on a freeway), the VDC may not operate normally, or the VDC warning lamp and the SLIP indicator lamp may turn on. This is not a problem if normal operation can be resumed after restarting the engine.
- Sudden turns (such as spin turns, acceleration turns), drifting, etc. with VDC turned off may cause the yaw rate/side/decel G sensor to indicate a problem. This is not a problem if normal operation can be resumed after restarting the engine.

Precaution for CAN System

INFOID:000000006147196

- Do not apply voltage of 7.0V or higher to terminal to be measured.
- Maximum open terminal voltage of tester in use must be less than 7.0V.
- Before checking harnesses, turn ignition switch OFF and disconnect battery negative cable.
- Area to be repaired must be soldered and wrapped with tape. Make sure that fraying of twisted wire is within 110 mm (4.33 in).

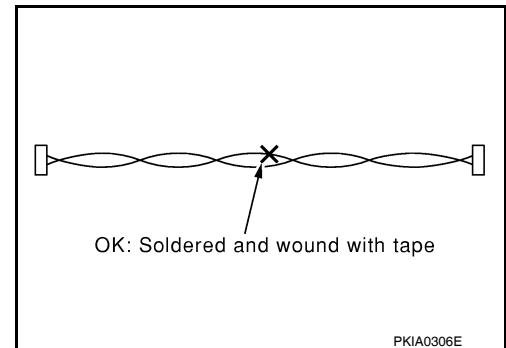

- Do not make a bypass connection to repaired area. (If the circuit is bypassed, characteristics of twisted wire will be lost.)

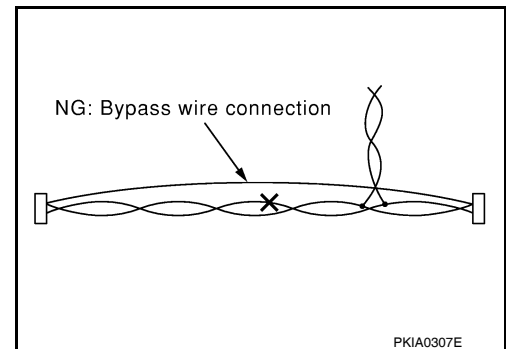

A
B
C
D
E
BRC
G
H
I
J
K
L
M
N
O
P

PREPARATION

< PREPARATION >

[VDC/TCS/ABS]

PREPARATION

PREPARATION

Special Service Tool

INFOID:000000006147197

The actual shapes of Kent-Moore tools may differ from those of special service tools illustrated here.

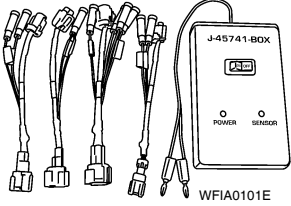
| Tool number (Kent-Moore No.) Tool name | Description |
|---|--|
| KV991J0080 (J-45741) ABS active wheel sensor tester | Checking operation of ABS active wheel sensors |
|  <p style="text-align: center;"><small>WPIA0101E</small></p> | |

Commercial Service Tool

INFOID:000000006147198

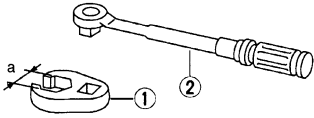
| Tool name | Description |
|--|---|
| 1. Flare nut crowfoot 2. Torque wrench | Removing and installing brake piping a: 10 mm (0.39 in)/12 mm (0.47 in) |
|  <p style="text-align: center;"><small>S-NT360</small></p> | |

WHEEL SENSORS

< UNIT REMOVAL AND INSTALLATION >

[VDC/TCS/ABS]

UNIT REMOVAL AND INSTALLATION

WHEEL SENSORS

Removal and Installation

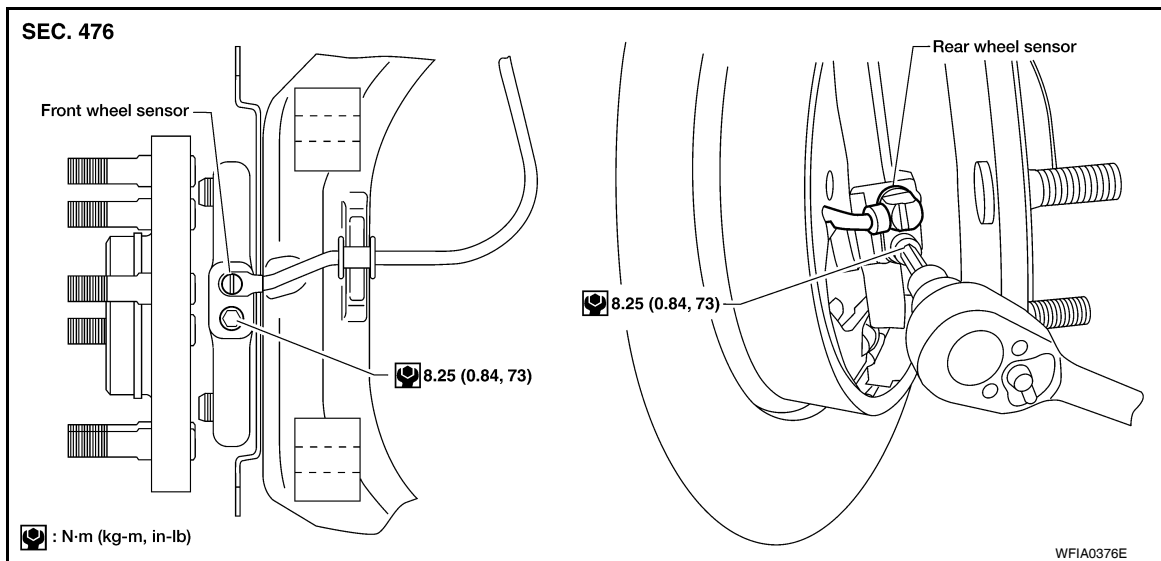

REMOVAL

1. Remove wheel sensor bolt.
 - When removing the front wheel sensor, first remove the disc rotor to gain access to the front wheel sensor bolt. Refer to [BR-37, "Removal and Installation of Brake Caliper and Disc Rotor"](#).
 - When removing the rear wheel sensor, first remove the rear hub and bearing assembly to gain access to the rear wheel sensor bolt. Refer to [RAX-7, "Removal and Installation"](#).
2. Pull out the sensor, being careful to turn it as little as possible.

CAUTION:

 - **Do not pull on the sensor harness.**
3. Disconnect wheel sensor harness electrical connector, then remove harness from attaching points.

INSTALLATION

Installation is in the reverse order of removal. Tighten wheel sensor bolt to specification.

CAUTION:

- **Inspect wheel sensor O-ring, replace sensor assembly if damaged.**
- **Before installing wheel sensor, make sure no foreign materials (such as iron fragments) are adhered to the pick-up part of the sensor, to the inside of the sensor hole or on the rotor mating surface.**
- **Apply a coat of suitable grease to the wheel sensor O-ring and hole. Refer to [GI-15, "Recommended Chemical Products and Sealants"](#).**

SENSOR ROTOR

< UNIT REMOVAL AND INSTALLATION >

[VDC/TCS/ABS]

SENSOR ROTOR

Removal and Installation

INFOID:000000006147200

NOTE:

The wheel sensor rotors are built into the wheel hubs and are not removable. If damaged, replace wheel hub and bearing assembly. Refer to [FAX-7, "Removal and Installation"](#) (front), [RAX-7, "Removal and Installation"](#) (rear).

ACTUATOR AND ELECTRIC UNIT (ASSEMBLY)

< UNIT REMOVAL AND INSTALLATION >

[VDC/TCS/ABS]

ACTUATOR AND ELECTRIC UNIT (ASSEMBLY)

Removal and Installation

INFOID:000000006147201

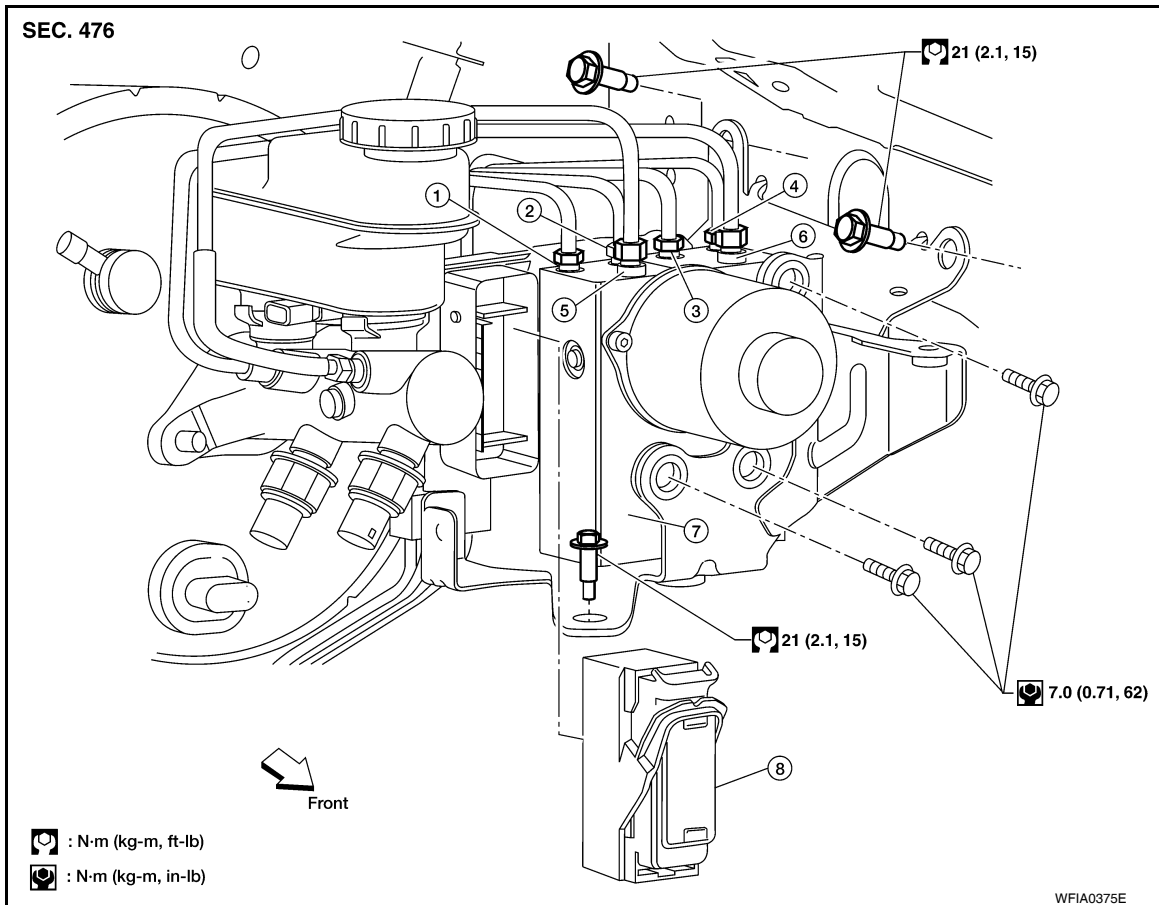

A
B
C
D
E
BRC
G
H
I
J
K
L
M
N
O
P

- | | | |
|--|---|---|
| 1. To rear left caliper 16.2 N·m (1.7 kg-m, 12 ft-lb) | 2. To rear right caliper 16.2 N·m (1.7 kg-m, 12 ft-lb) | 3. To front left caliper 16.2 N·m (1.7 kg-m, 12 ft-lb) |
| 4. To front right caliper 16.2 N·m (1.7 kg-m, 12 ft-lb) | 5. From the master cylinder secondary side 18.2 N·m (1.9 kg-m, 13 ft-lb) | 6. From the master cylinder primary side 18.2 N·m (1.9 kg-m, 13 ft-lb) |
| 7. ABS actuator and electric unit (control unit) | 8. Actuator harness connector | |

REMOVAL

1. Disconnect the battery negative terminal. Refer to [PG-76, "Removal and Installation"](#).
2. Remove the air cleaner and air duct resonator assembly. Refer to [EM-25, "Removal and Installation"](#).
3. Drain the brake fluid. Refer to [BR-17, "Drain and Refill"](#).
4. Disconnect the actuator harness connector from the ABS actuator and electric unit (control unit).

CAUTION:

- To remove the brake tubes, use a flare nut wrench to prevent the flare nuts and brake tubes from being damaged.
- Be careful not to splash brake fluid on painted areas; it may cause paint damage. If brake fluid is splashed on painted areas, wash it away with water immediately.

5. Disconnect the brake tubes.
6. Remove the three bolts and remove the ABS actuator and electric unit (control unit).

INSTALLATION

Installation is in the reverse order of removal.

CAUTION:

- To install, use a flare nut crowfoot and torque wrench (commercial service tools).

ACTUATOR AND ELECTRIC UNIT (ASSEMBLY)

< UNIT REMOVAL AND INSTALLATION >

[VDC/TCS/ABS]

- Always tighten brake tubes to specification when installing.
- Never reuse drained brake fluid.
- After installation of the ABS actuator and electric unit (control unit), perform the following.
- Refill brake system with new brake fluid. Then bleed the air from the system. Refer to [BR-17, "Bleeding Brake System"](#).
- Adjust the steering angle sensor. Refer to [BRC-8, "ADJUSTMENT OF STEERING ANGLE SENSOR NEUTRAL POSITION : Special Repair Requirement"](#).
- Calibrate the decel G sensor. Refer to [BRC-9, "CALIBRATION OF DECEL G SENSOR : Special Repair Requirement"](#).

STEERING ANGLE SENSOR

< UNIT REMOVAL AND INSTALLATION >

[VDC/TCS/ABS]

STEERING ANGLE SENSOR

Removal and Installation

INFOID:000000006147202

REMOVAL

1. Remove spiral cable. Refer to [SR-7. "Removal and Installation"](#).
2. Remove the screws and remove the steering angle sensor.

INSTALLATION

Installation is in the reverse order of removal.

CAUTION:

After installation, adjust steering angle sensor. Refer to [BRC-8. "ADJUSTMENT OF STEERING ANGLE SENSOR NEUTRAL POSITION : Special Repair Requirement"](#).

A
B
C
D
E
G
H
I
J
K
L
M
N
O
P

BRC

G SENSOR

< UNIT REMOVAL AND INSTALLATION >

[VDC/TCS/ABS]

G SENSOR

Removal and Installation

INFOID:000000006147203

REMOVAL

1. Remove front center console. Refer to [IP-21. "Removal and Installation"](#).
2. Remove yaw rate/side/decel G sensor attaching nuts.
CAUTION:
 - Do not use power tools to remove or install yaw rate/side/decel G sensor.
 - Do not drop or strike the yaw rate/side/decel G sensor.
3. Disconnect harness connector and remove the yaw rate/side/decel G sensor.

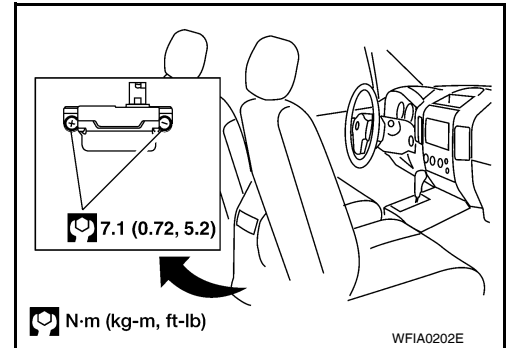

INSTALLATION

Installation is in the reverse order of removal.

CAUTION:

- Do not drop or strike the yaw rate/side/decel G sensor.
- After installation, calibrate the yaw rate/side/decel G sensor. Refer to [BRC-9. "CALIBRATION OF DECEL G SENSOR : Special Repair Requirement"](#).