

SECTION **CHG**
CHARGING SYSTEM

A
B
C
D
E
F
G
H
I
J
K
L
CHG
N
O
P

CONTENTS

PRECAUTION	2	Inspection Procedure	8
PRECAUTIONS	2	POWER GENERATION VOLTAGE VARIABLE CONTROL SYSTEM OPERATION INSPECTION	9
Precaution for Supplemental Restraint System (SRS) "AIR BAG" and "SEAT BELT PRE-TENSIONER"	2	Inspection Procedure	9
Precaution Necessary for Steering Wheel Rotation After Battery Disconnect	2	B TERMINAL CIRCUIT	11
Precaution for Power Generation Variable Voltage Control System	3	Description	11
PREPARATION	4	Diagnosis Procedure	11
PREPARATION	4	L TERMINAL CIRCUIT	12
Special Service Tool	4	Description	12
Commercial Service Tool	4	Diagnosis Procedure	12
BASIC INSPECTION	5	S TERMINAL CIRCUIT	13
DIAGNOSIS AND REPAIR WORKFLOW	5	Description	13
Work Flow	5	Diagnosis Procedure	13
SYSTEM DESCRIPTION	6	WIRING DIAGRAM	14
CHARGING SYSTEM	6	CHARGING SYSTEM	14
System Diagram	6	Wiring Diagram	14
System Description	6	SYMPTOM DIAGNOSIS	20
Component Description	6	CHARGING SYSTEM	20
POWER GENERATION VOLTAGE VARIABLE CONTROL SYSTEM	7	Symptom Table	20
System Diagram	7	REMOVAL AND INSTALLATION	21
System Description	7	GENERATOR	21
Component Description	7	Removal and Installation	21
DTC/CIRCUIT DIAGNOSIS	8	SERVICE DATA AND SPECIFICATIONS (SDS)	22
CHARGING SYSTEM PRELIMINARY INSPECTION	8	GENERATOR	22
		Generator	22

PRECAUTIONS

< PRECAUTION >

PRECAUTION

PRECAUTIONS

Precaution for Supplemental Restraint System (SRS) "AIR BAG" and "SEAT BELT PRE-TENSIONER"

INFOID:000000006144169

The Supplemental Restraint System such as "AIR BAG" and "SEAT BELT PRE-TENSIONER", used along with a front seat belt, helps to reduce the risk or severity of injury to the driver and front passenger for certain types of collision. This system includes seat belt switch inputs and dual stage front air bag modules. The SRS system uses the seat belt switches to determine the front air bag deployment, and may only deploy one front air bag, depending on the severity of a collision and whether the front occupants are belted or unbelted. Information necessary to service the system safely is included in the SR and SB section of this Service Manual.

WARNING:

- To avoid rendering the SRS inoperative, which could increase the risk of personal injury or death in the event of a collision which would result in air bag inflation, all maintenance must be performed by an authorized NISSAN/INFINITI dealer.
- Improper maintenance, including incorrect removal and installation of the SRS, can lead to personal injury caused by unintentional activation of the system. For removal of Spiral Cable and Air Bag Module, see the SR section.
- Do not use electrical test equipment on any circuit related to the SRS unless instructed to in this Service Manual. SRS wiring harnesses can be identified by yellow and/or orange harnesses or harness connectors.

PRECAUTIONS WHEN USING POWER TOOLS (AIR OR ELECTRIC) AND HAMMERS

WARNING:

- When working near the Airbag Diagnosis Sensor Unit or other Airbag System sensors with the Ignition ON or engine running, DO NOT use air or electric power tools or strike near the sensor(s) with a hammer. Heavy vibration could activate the sensor(s) and deploy the air bag(s), possibly causing serious injury.
- When using air or electric power tools or hammers, always switch the Ignition OFF, disconnect the battery, and wait at least 3 minutes before performing any service.

Precaution Necessary for Steering Wheel Rotation After Battery Disconnect

INFOID:000000006144170

NOTE:

- This Procedure is applied only to models with Intelligent Key system and NATS (NISSAN ANTI-THEFT SYSTEM).
- Remove and install all control units after disconnecting both battery cables with the ignition knob in the "LOCK" position.
- Always use CONSULT-III to perform self-diagnosis as a part of each function inspection after finishing work. If DTC is detected, perform trouble diagnosis according to self-diagnostic results.

For models equipped with the Intelligent Key system and NATS, an electrically controlled steering lock mechanism is adopted on the key cylinder.

For this reason, if the battery is disconnected or if the battery is discharged, the steering wheel will lock and steering wheel rotation will become impossible.

If steering wheel rotation is required when battery power is interrupted, follow the procedure below before starting the repair operation.

OPERATION PROCEDURE

1. Connect both battery cables.

NOTE:

Supply power using jumper cables if battery is discharged.

2. Use the Intelligent Key or mechanical key to turn the ignition switch to the "ACC" position. At this time, the steering lock will be released.
3. Disconnect both battery cables. The steering lock will remain released and the steering wheel can be rotated.
4. Perform the necessary repair operation.

PRECAUTIONS

< PRECAUTION >

5. When the repair work is completed, return the ignition switch to the "LOCK" position before connecting the battery cables. (At this time, the steering lock mechanism will engage.)
6. Perform a self-diagnosis check of all control units using CONSULT-III.

Precaution for Power Generation Variable Voltage Control System

INFOID:000000006144171

CAUTION:

For this model, the battery current sensor that is installed to the negative battery cable measures the charging/discharging current of the battery and performs various engine controls. If an electrical component is connected directly to the negative battery terminal, the current flowing through that component will not be measured by the battery current sensor. This condition may cause a malfunction of the engine control system and battery discharge may occur. Do not connect an electrical component or ground wire directly to the battery terminal.

A
B
C
D
E
F
G
H
I
J
K
L

CHG

N
O
P

PREPARATION

< PREPARATION >

PREPARATION

PREPARATION

Special Service Tool

INFOID:000000006144172

The actual shapes of Kent-Moore tools may differ from those of special service tools illustrated here.

Tool number (Kent-Moore No.) Tool name	Description
— (—) Model GR-8 Multitasking Battery Diagnostic Station	Tests batteries, starting and charging systems. For operating instructions, refer to diagnostic station instruction manual.



AWI1A1239ZZ

Commercial Service Tool

INFOID:000000006144173

Tool name	Description
Power tool	Loosening bolts and nuts

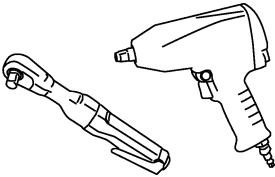

PBIC0190E

DIAGNOSIS AND REPAIR WORKFLOW

< BASIC INSPECTION >

BASIC INSPECTION

DIAGNOSIS AND REPAIR WORKFLOW

Work Flow

INFOID:000000006144174

OVERALL SEQUENCE

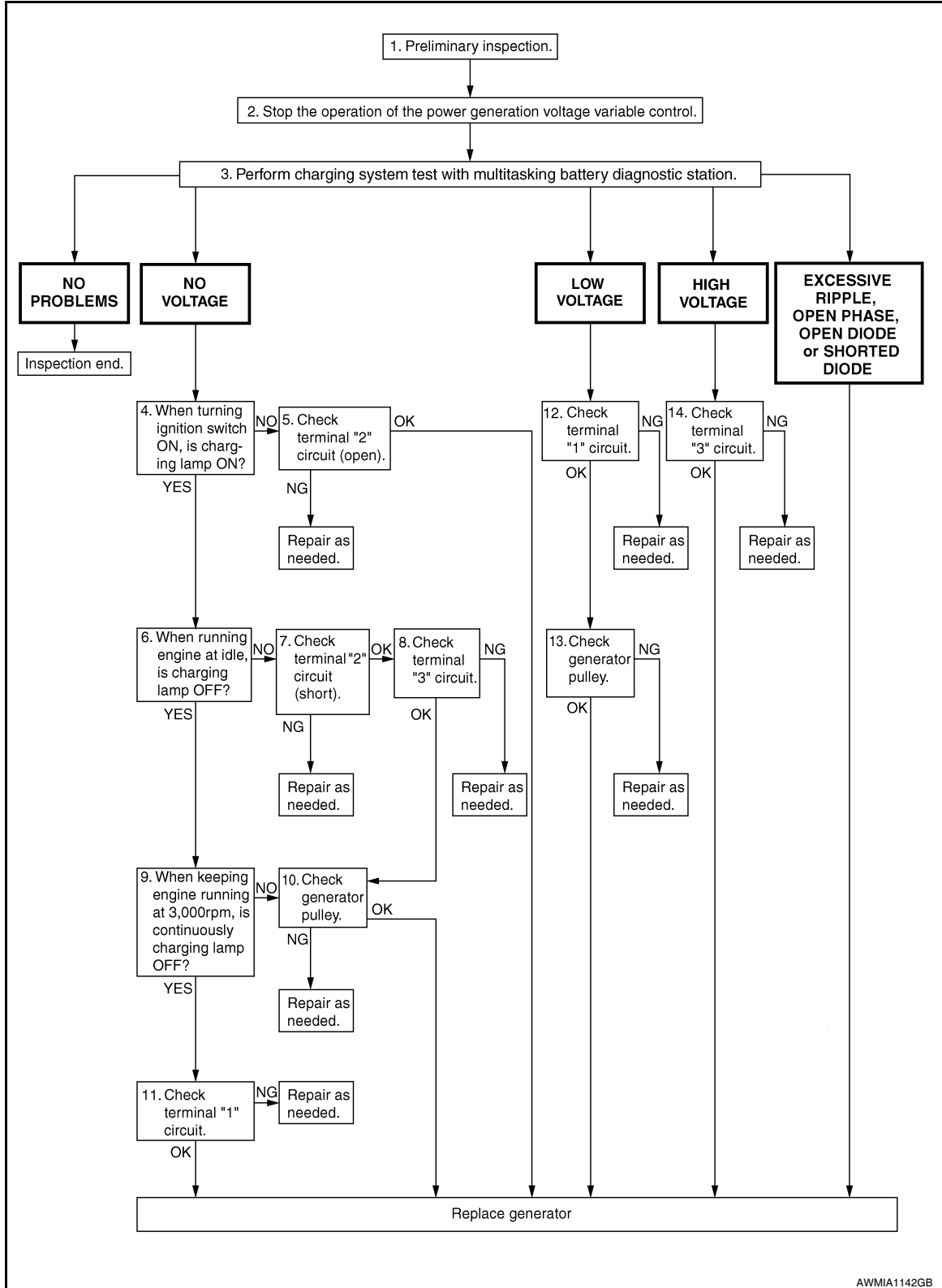

AWMIA1142GB

A
B
C
D
E
F
G
H
I
J
K
L
CHG
N
O
P

CHARGING SYSTEM

< SYSTEM DESCRIPTION >

SYSTEM DESCRIPTION

CHARGING SYSTEM

System Diagram

INFOID:000000006144175

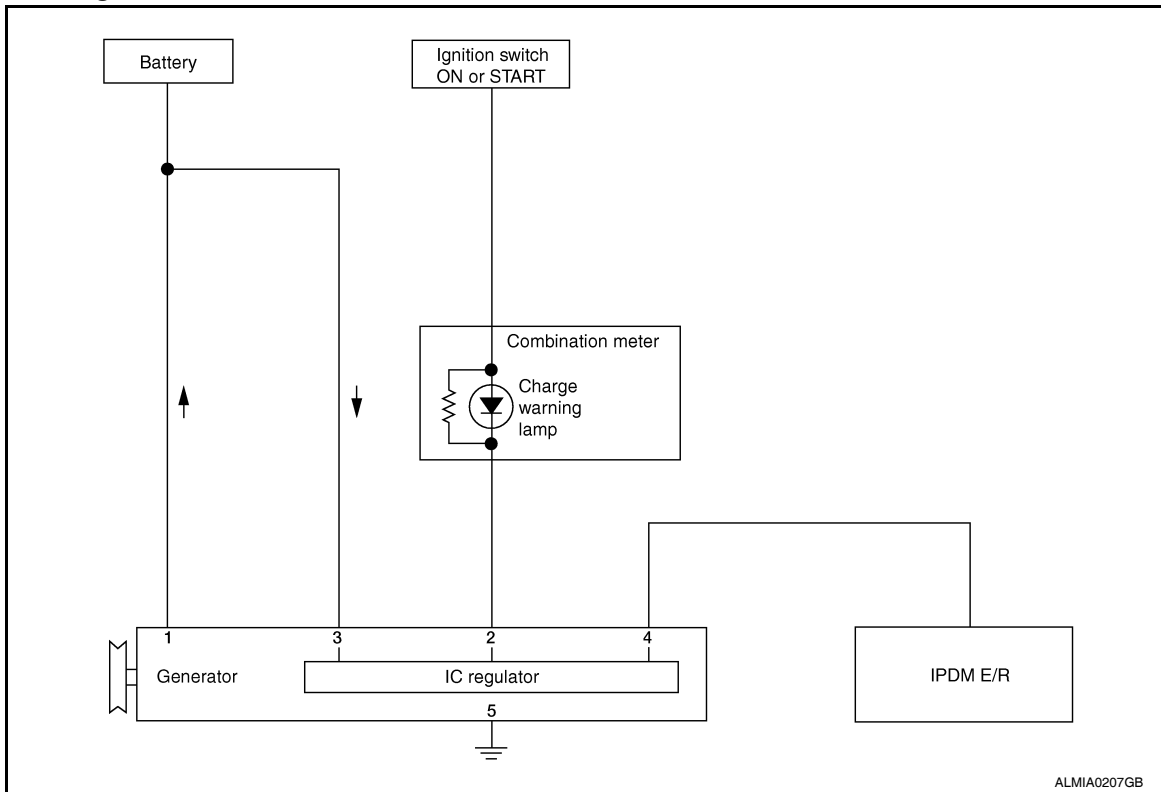

ALMIA0207GB

System Description

INFOID:000000006144176

The generator provides DC voltage to operate the vehicle's electrical system and to keep the battery charged. The voltage output is controlled by the IC regulator.

Component Description

INFOID:000000006144177

Component part		Description
Generator	Terminal "1"	Refer to CHG-11, "Description" .
	Terminal "2"	Refer to CHG-12, "Description" .
	Terminal "3"	Refer to CHG-13, "Description" .
	Terminal "4"	Used for the power generation voltage variable control system. Refer to CHG-7, "System Description" .
Combination meter (Charge warning lamp)		The IC regulator warning function activates to illuminate the charge warning lamp if any of the following symptoms occur while generator is operating: <ul style="list-style-type: none"> Excessive voltage is produced. No voltage is produced.
IPDM E/R		Used for the power generation voltage variable control system. Refer to CHG-7, "System Description" .

POWER GENERATION VOLTAGE VARIABLE CONTROL SYSTEM

< SYSTEM DESCRIPTION >

POWER GENERATION VOLTAGE VARIABLE CONTROL SYSTEM

System Diagram

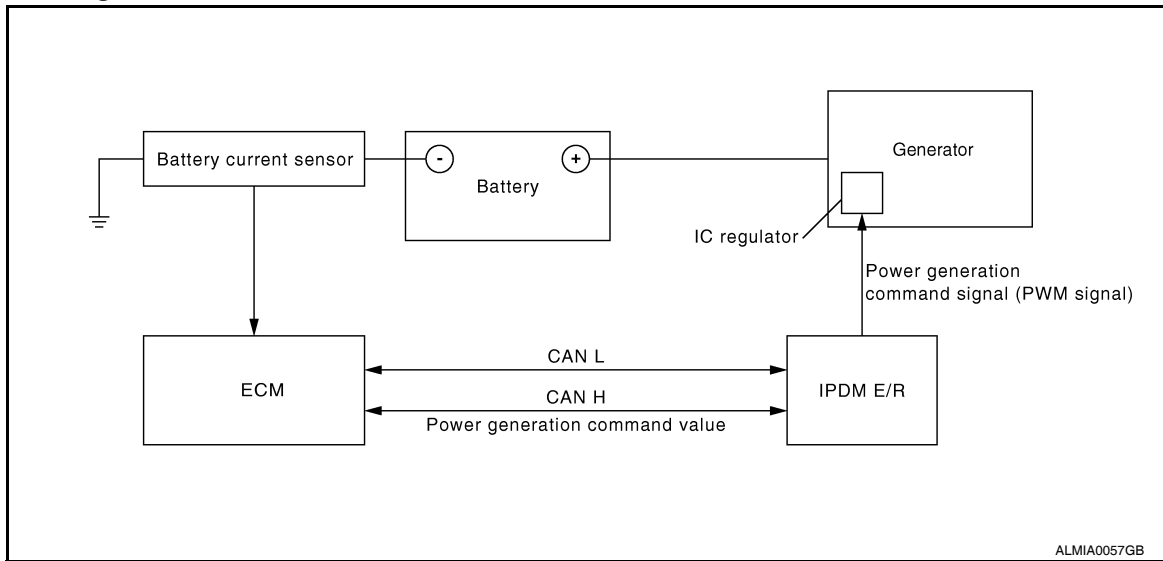

System Description

Power generation variable voltage control system has been adopted. By varying the voltage to the generator, engine load due to power generation of the generator is reduced and fuel consumption is decreased.

NOTE:

When any malfunction is detected in the power generation variable voltage control system, power generation is performed according to the characteristic of the IC regulator in the generator.

Component Description

Component part	Description
Battery current sensor	The battery current sensor is installed on the battery cable at the negative terminal. The battery current sensor detects the charging/discharging current of the battery and sends a voltage signal to the ECM according to the current value detected.
ECM	The battery current sensor detects the charging/discharging current of the battery. The ECM judges the battery condition based on this signal. The ECM judges whether to request more output via the power generation voltage variable control according to the battery condition. When performing the power generation voltage variable control, the ECM calculates the target power generation voltage according to the battery condition and sends the calculated value as the power generation command value to the IPDM E/R.
IPDM E/R	The IPDM E/R converts the received power generation command value into a pulse width modulated (PWM) command signal and sends it to the IC regulator.
Generator (IC regulator)	The IC regulator controls the power generation voltage by the target power generation voltage based on the received PWM command signal. When there is no PWM command signal, the generator performs the normal power generation according to the characteristic of the IC regulator.

CHARGING SYSTEM PRELIMINARY INSPECTION

< DTC/CIRCUIT DIAGNOSIS >

DTC/CIRCUIT DIAGNOSIS

CHARGING SYSTEM PRELIMINARY INSPECTION

Inspection Procedure

INFOID:000000006144181

1. CHECK BATTERY TERMINALS CONNECTION

Check if battery terminals are clean and tight.

Is the inspection result normal?

YES >> GO TO 2.

NO >> Repair battery terminals connection.

2. CHECK FUSE

Check for blown fuse and fusible link.

Unit	Power source (Power supply terminals)	Fuse or Fusible Link
Generator	Battery (terminal 3)	Fuse 30
	Battery (terminal 1)	Fusible Link A
Combination meter	Ignition switch ON (terminal 2)	Fuse 14

Is the inspection result normal?

YES >> GO TO 3.

NO >> Be sure to eliminate cause of malfunction before installing new fuse or fusible link.

3. CHECK GENERATOR GROUND TERMINAL CONNECTION

Verify connector E206 terminal 5 (generator ground harness) is clean and tight.

Is the inspection result normal?

YES >> GO TO 4.

NO >> Repair connection.

4. CHECK DRIVE BELT TENSION

Check drive belt tension. Refer to [EM-13. "Checking Drive Belts"](#).

Is the inspection result normal?

YES >> Inspection End.

NO >> Repair as needed.

POWER GENERATION VOLTAGE VARIABLE CONTROL SYSTEM OPERATION INSPECTION

< DTC/CIRCUIT DIAGNOSIS >

POWER GENERATION VOLTAGE VARIABLE CONTROL SYSTEM OPERATION INSPECTION

Inspection Procedure

INFOID:000000006144182

Regarding Wiring Diagram information, refer to [CHG-14. "Wiring Diagram"](#).

CAUTION:

When performing this inspection, always use a charged battery that has completed the battery inspection. (When the charging rate of the battery is low, the response speed of the voltage change will become slow. This can cause an incorrect inspection.)

1. CHECK ECM (CONSULT-III)

Perform ECM self-diagnosis with CONSULT-III. Refer to [EC-50. "CONSULT-III Function"](#).

Self-diagnostic results content

No malfunction detected>> GO TO 2.

Malfunction detected>> Check applicable parts, and repair or replace corresponding parts.

2. CHECK OPERATION OF POWER GENERATION VOLTAGE VARIABLE CONTROL SYSTEM

1. Connect CONSULT-III and start the engine.
2. The selector lever is in "P" or "N" position and all of the electric loads and A/C, etc. are turned OFF.
3. Select "ALTERNATOR DUTY" in "Active Test" of "ENGINE", and then check the value of "BATTERY VOLT" monitor when DUTY value of "ALTERNATOR DUTY" is set to 40.0 %.

"BATTERY VOLT"

2 seconds after setting the DUTY value of "ALTERNATOR DUTY" to 40.0 % : 12 - 13.6 V

4. Check the value of "BATTERY VOLT" monitor when DUTY value of "ALTERNATOR DUTY" is set to 80.0%.

"BATTERY VOLT"

20 seconds after setting the DUTY value of "ALTERNATOR DUTY" to 80.0 % : +0.5 V or more against the value of "BATTERY VOLT" monitor when DUTY value is 40.0 %

Is the measurement value within specification?

YES >> Inspection End.

NO >> GO TO 3.

3. CHECK IPDM E/R (CONSULT-III)

Perform IPDM E/R self-diagnosis with CONSULT-III. Refer to [PCS-14. "CONSULT - III Function \(IPDM E/R\)"](#).

Self-diagnostic results content

No malfunction detected>> GO TO 4.

Malfunction detected>> Check applicable parts, and repair or replace corresponding parts.

4. CHECK HARNESS BETWEEN GENERATOR AND IPDM E/R

POWER GENERATION VOLTAGE VARIABLE CONTROL SYSTEM OPERATION INSPECTION

< DTC/CIRCUIT DIAGNOSIS >

1. Turn ignition switch OFF.
2. Disconnect generator connector E205 and IPDM E/R connector E122.
3. Check continuity between generator harness connector E205 (A) terminal 4 and IPDM E/R harness connector E122 (B) terminal 37.

A		B		Continuity
Connector	Terminal	Connector	Terminal	
E205	4	E122	37	Yes

4. Check continuity between generator harness connector E122 (A) terminal 4 and ground.

A		—	Continuity
Connector	Terminal		
E205	4	Ground	No

Are the continuity test results as specified?

- YES >> Replace IPDM E/R. Refer to [PCS-31, "Removal and Installation of IPDM E/R"](#).
 NO >> Repair harness or connector between IPDM E/R and generator.

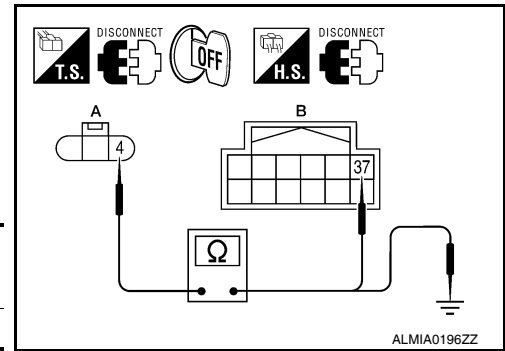

B TERMINAL CIRCUIT

< DTC/CIRCUIT DIAGNOSIS >

B TERMINAL CIRCUIT

Description

INFOID:000000006144183

The terminal "1" circuit supplies power to charge the battery and operate the vehicles electrical system.

Diagnosis Procedure

INFOID:000000006144184

Regarding Wiring Diagram information, refer to [CHG-14, "Wiring Diagram"](#).

1. CHECK TERMINAL "1" CONNECTION

1. Turn ignition switch OFF.
2. Verify terminal "1" is clean and tight.

Is the inspection result normal?

YES >> GO TO 2.

NO >> Repair terminal "1" connection. Confirm repair by performing complete Starting/Charging system test. Refer to diagnostic station instruction manual.

2. CHECK TERMINAL "1" CIRCUIT

Check voltage between generator connector E204 terminal 1 and ground.

(+)		(-)	Voltage
Connector	Terminal		
E204	1	Ground	Battery voltage

Is voltage reading as specified?

YES >> GO TO 3.

NO >> Check harness for open between generator and fusible link.

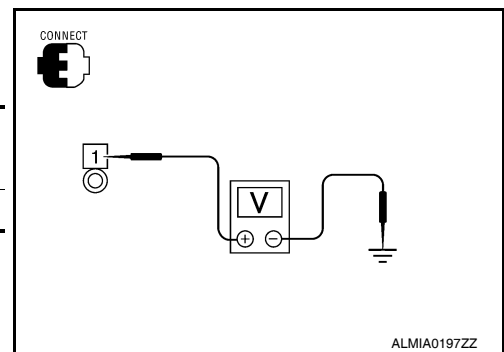

ALMIA0197ZZ

3. CHECK TERMINAL "1" CONNECTION (VOLTAGE DROP TEST)

1. Start engine, then engine running at idle and warm.
2. Check voltage between battery positive terminal and generator connector E204 terminal 1.

(+)		(-)	Voltage
Connector	Terminal		
E204	1	Battery positive terminal	Less than 0.2V

Is the voltage reading as specified?

YES >> Terminal "1" circuit is normal. Refer to [CHG-5, "Work Flow"](#).

NO >> Check harness between battery and generator for high resistance.

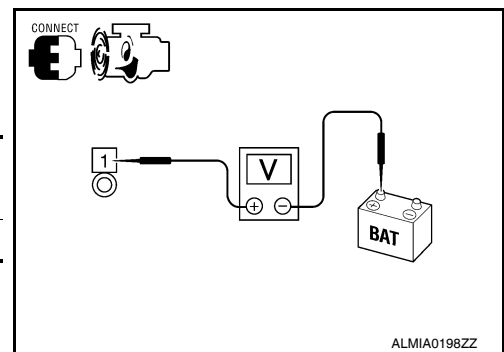

ALMIA0198ZZ

A
B
C
D
E
F
G
H
I
J
K
L
CHG
N
O
P

L TERMINAL CIRCUIT

< DTC/CIRCUIT DIAGNOSIS >

L TERMINAL CIRCUIT

Description

INFOID:000000006144185

The terminal "2" (L) circuit controls the charge warning lamp. The charge warning lamp illuminates when the ignition switch is set to ON or START. When the generator is providing sufficient voltage with the engine running, the charge warning lamp will go off. If the charge warning lamp illuminates with the engine running, a malfunction is indicated.

Diagnosis Procedure

INFOID:000000006144186

Regarding Wiring Diagram information, refer to [CHG-14, "Wiring Diagram"](#).

1. CHECK CHARGE WARNING LAMP CIRCUIT CONNECTION

Verify generator connector E205 terminal 2 is clean and tight.

Is the connection secure?

YES >> GO TO 2.

NO >> Repair the connection. Confirm repair by performing complete Starting/Charging system test. Refer to diagnostic station instruction manual.

2. CHECK CHARGE WARNING LAMP CIRCUIT

1. Disconnect generator connector E205.
2. Apply ground to generator harness connector E205 terminal 2 with the ignition switch in the ON position.

Charge lamp should illuminate

Does the charge lamp illuminate?

YES >> Check generator function. Refer to [CHG-5, "Work Flow"](#).

NO >> GO TO 3.

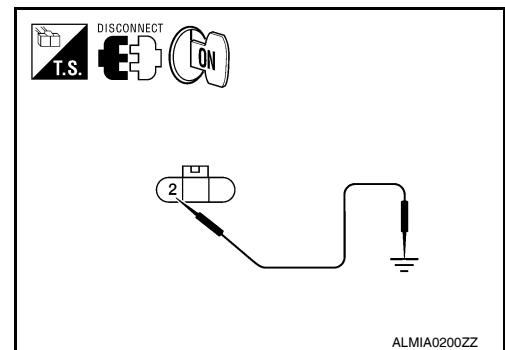

3. CHECK HARNESS CONTINUITY

1. Turn ignition switch OFF.
2. Disconnect the generator connector E205 and combination meter connector M23.
3. Check continuity between generator harness connector E205 (A) terminal 2 and combination meter harness connector M23 (B) terminal 45.

A		B		Continuity
Connector	Terminal	Connector	Terminal	
E205	2	M23	45	Yes

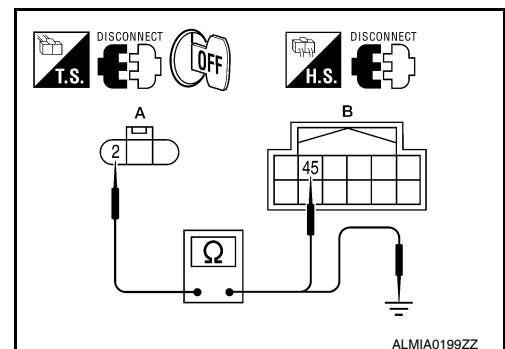

4. Check continuity between generator harness connector E205 (A) terminal 2 and ground.

A		—	Continuity
Connector	Terminal		
E205	2	Ground	No

Are the continuity results as specified?

YES >> Replace the combination meter. Refer to [MWI-97, "Removal and Installation"](#).

NO >> Repair the harness or connector.

S TERMINAL CIRCUIT

< DTC/CIRCUIT DIAGNOSIS >

S TERMINAL CIRCUIT

Description

INFOID:000000006144187

The output voltage of the generator is controlled by the IC regulator at terminal "3" (S) detecting the input voltage. Terminal "3" circuit detects the battery voltage to adjust the generator output voltage with the IC regulator.

Diagnosis Procedure

INFOID:000000006144188

Regarding Wiring Diagram information, refer to [CHG-14, "Wiring Diagram"](#).

1. CHECK VOLTAGE REGULATOR CIRCUIT CONNECTION

Check to see if connector E205 terminal 3 is clean and tight.

Is the inspection result normal?

YES >> GO TO 2.

NO >> Repair terminal connection. Confirm repair by performing complete Starting/Charging system test.
Refer to diagnostic station instruction manual.

2. CHECK VOLTAGE REGULATOR CIRCUIT

Check voltage between generator harness connector E205 terminal 3 and ground.

3 - ground

Battery voltage

Does battery voltage exist?

YES >> Refer to [CHG-5, "Work Flow"](#).

NO >> Check harness for open between generator and fuse.

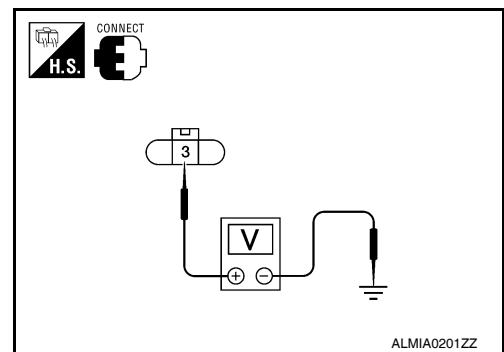

A
B
C
D
E
F
G
H
I
J
K
L
N
O
P

CHG

CHARGING SYSTEM

< WIRING DIAGRAM >

WIRING DIAGRAM

CHARGING SYSTEM

Wiring Diagram

INFOID:000000006418487

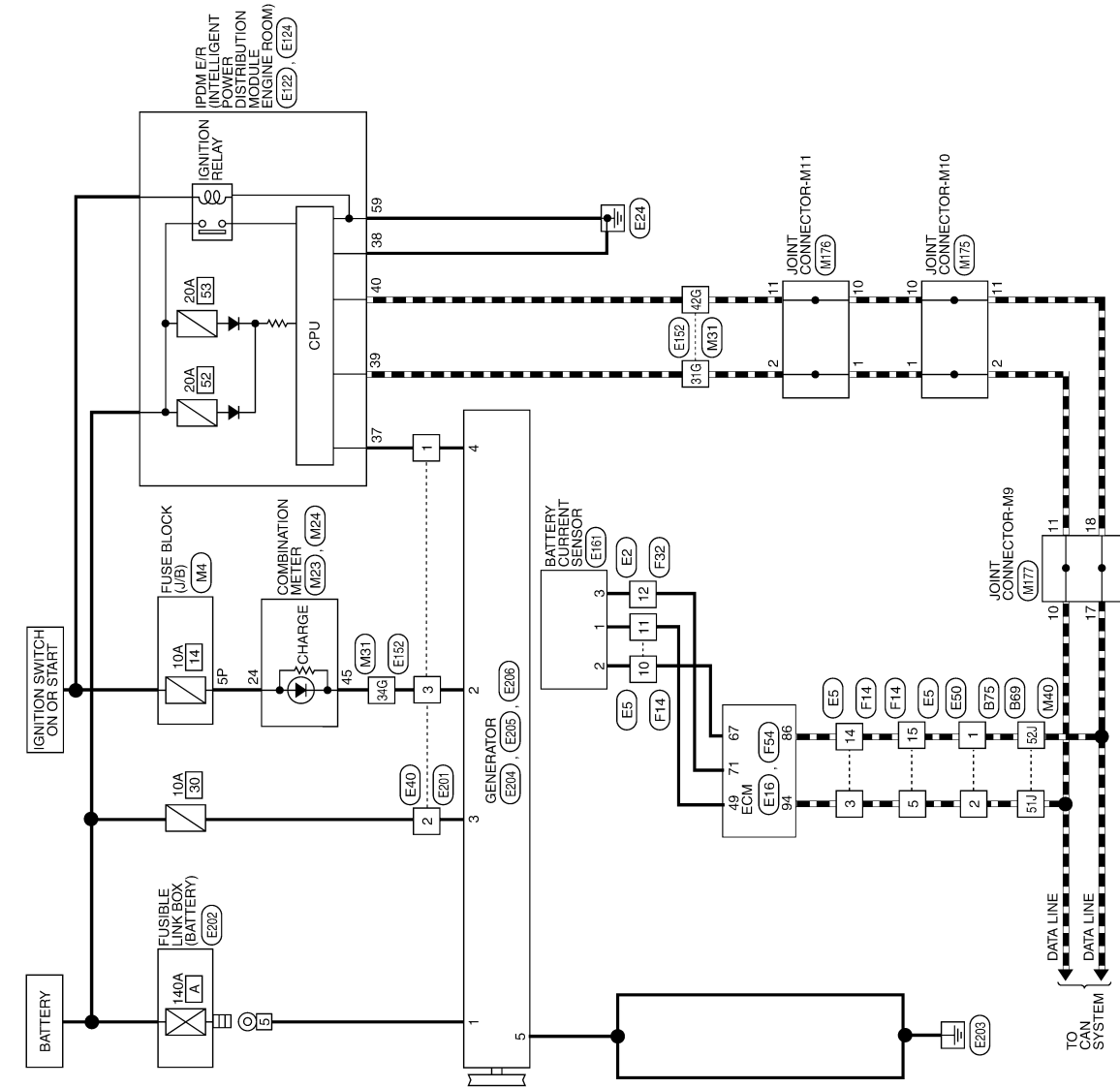

CHARGING SYSTEM

ABMWA1046GB

CHARGING SYSTEM CONNECTORS

Connector No.	M4
Connector Name	FUSE BLOCK (J/B)
Connector Color	WHITE



Terminal No.	Color of Wire	Signal Name
5P	O/L	-

Connector No.	M23
Connector Name	COMBINATION METER
Connector Color	WHITE

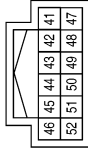

Terminal No.	Color of Wire	Signal Name
45	BR/W	CHARGE IN

Connector No.	M24
Connector Name	COMBINATION METER
Connector Color	WHITE

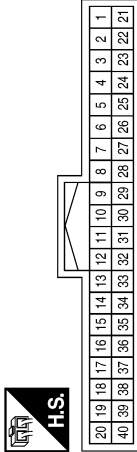

Terminal No.	Color of Wire	Signal Name
24	O/L	RUN/START

Connector No.	M31
Connector Name	WIRE TO WIRE
Connector Color	WHITE

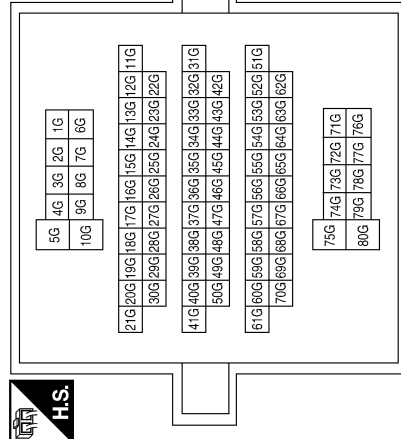

Terminal No.	Color of Wire	Signal Name
31G	L	-
34G	BR/W	-
42G	P	-

Connector No.	M40
Connector Name	WIRE TO WIRE
Connector Color	WHITE

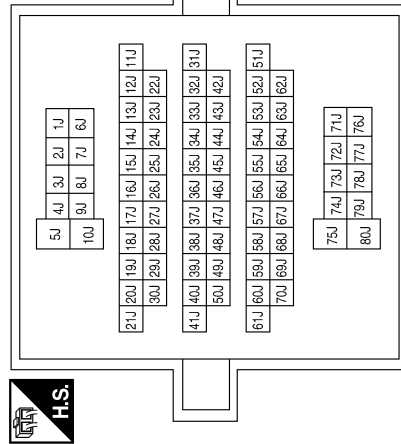

Terminal No.	Color of Wire	Signal Name
51J	L	-
52J	P	-

Connector No.	M175
Connector Name	JOINT CONNECTOR-M10
Connector Color	BLUE

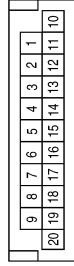

Terminal No.	Color of Wire	Signal Name
1	L	-
2	L	-
10	P	-
11	P	-

ABMIA2482GB

A
B
C
D
E
F
G
H
I
J
K
L
M
N
O
P

CHG

CHARGING SYSTEM

< WIRING DIAGRAM >

Connector No.	E2
Connector Name	WIRE TO WIRE
Connector Color	WHITE

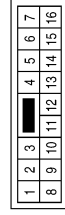

Terminal No.	Color of Wire	Signal Name
12	R	-

Connector No.	M177
Connector Name	JOINT CONNECTOR-M9
Connector Color	GREEN

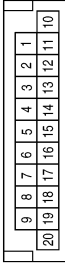

Terminal No.	Color of Wire	Signal Name
10	L	-
11	L	-
17	P	-
18	P	-

Connector No.	M176
Connector Name	JOINT CONNECTOR-M11
Connector Color	BLUE

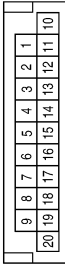

Terminal No.	Color of Wire	Signal Name
1	L	-
2	L	-
10	P	-
11	P	-

Connector No.	E40
Connector Name	WIRE TO WIRE
Connector Color	BLACK



Terminal No.	Color of Wire	Signal Name
1	Y	-
2	Y/B	-
3	BR/W	-

Connector No.	E16
Connector Name	ECM
Connector Color	BLACK

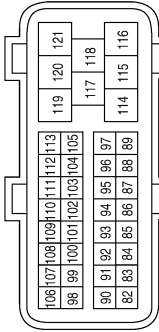

Terminal No.	Color of Wire	Signal Name
86	P	CAN-L
94	L	CAN-H

Connector No.	E5
Connector Name	WIRE TO WIRE
Connector Color	WHITE

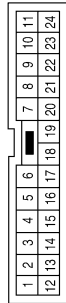

Terminal No.	Color of Wire	Signal Name
3	L	-
5	L	-
10	B	-
11	R/Y	-
14	P	-
15	P	-

ABMIA2476GB

CHARGING SYSTEM

< WIRING DIAGRAM >

Connector No.	E124
Connector Name	IPDM E/R (INTELLIGENT POWER DISTRIBUTION MODULE ENGINE ROOM)
Connector Color	BLACK



59	58	57
62	61	60

Terminal No.	Color of Wire	Signal Name
59	B	GND (POWER)

Connector No.	E122
Connector Name	IPDM E/R (INTELLIGENT POWER DISTRIBUTION MODULE ENGINE ROOM)
Connector Color	WHITE



42	41	40	39	38	37
48	47	46	45	44	43

Terminal No.	Color of Wire	Signal Name
37	Y	ALT-C CONT
38	B	GND (SIGNAL)
39	L	CAN-H
40	P	CAN-L

Connector No.	E50
Connector Name	WIRE TO WIRE
Connector Color	BROWN



2	1
---	---

Terminal No.	Color of Wire	Signal Name
1	P	-
2	L	-

Connector No.	E161
Connector Name	BATTERY CURRENT SENSOR
Connector Color	BLACK



1	2	3
---	---	---

Terminal No.	Color of Wire	Signal Name
1	R/Y	-
2	B	-
3	R	-

Terminal No.	Color of Wire	Signal Name
31G	L	-
34G	BR/W	-
42G	P	-

Connector No.	E152
Connector Name	WIRE TO WIRE
Connector Color	WHITE

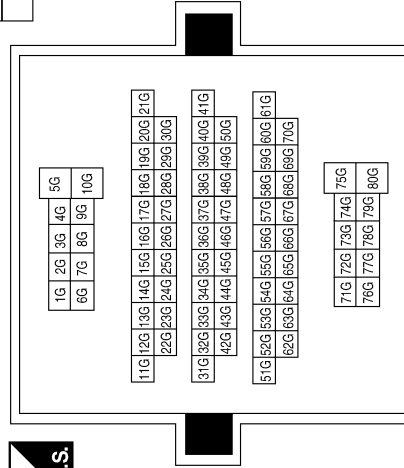

ABMIA2483GB

A
B
C
D
E
F
G
H
I
J
K
L
N
O
P

CHG

CHARGING SYSTEM

< WIRING DIAGRAM >

Connector No.	E201
Connector Name	WIRE TO WIRE
Connector Color	BLACK



Terminal No.	Color of Wire	Signal Name
1	Y	-
2	Y/B	-
3	BR/W	-

Connector No.	E202
Connector Name	FUSIBLE LINK BOX (BATTERY)
Connector Color	-



Terminal No.	Color of Wire	Signal Name
5	B/R	-

Connector No.	E204
Connector Name	GENERATOR
Connector Color	-



Terminal No.	Color of Wire	Signal Name
1	B/R	-

Connector No.	E205
Connector Name	GENERATOR
Connector Color	BLACK



Terminal No.	Color of Wire	Signal Name
2	BR/W	-
3	Y/B	-
4	Y	-

Connector No.	E206
Connector Name	GENERATOR
Connector Color	-



Terminal No.	Color of Wire	Signal Name
5	B	-

Connector No.	F14
Connector Name	WIRE TO WIRE
Connector Color	WHITE

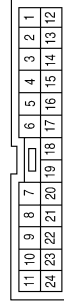

Terminal No.	Color of Wire	Signal Name
3	L	-
5	L	-
10	B	-
11	R/Y	-
14	P	-
15	P	-

CHARGING SYSTEM

< WIRING DIAGRAM >

Connector No.	F32
Connector Name	WIRE TO WIRE
Connector Color	WHITE

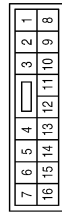

Terminal No.	Color of Wire	Signal Name
12	R	-

Connector No.	F54
Connector Name	ECM
Connector Color	BLACK

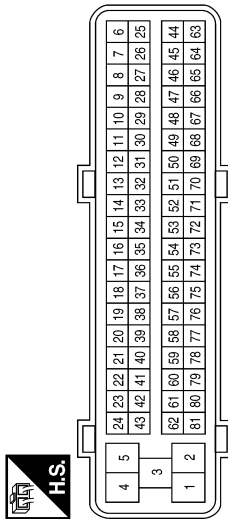

Terminal No.	Color of Wire	Signal Name
49	R/Y	AVCC (PDPRES)
67	B	GND-A
71	R	CURSEN

Connector No.	B69
Connector Name	WIRE TO WIRE
Connector Color	WHITE

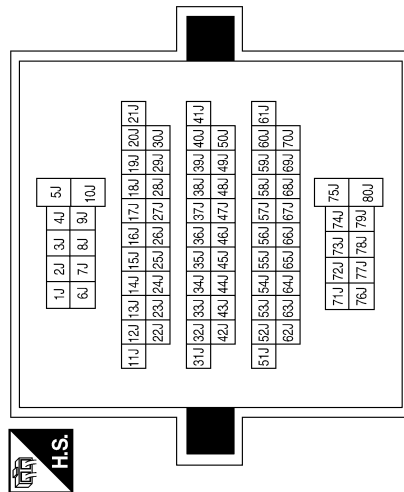

Terminal No.	Color of Wire	Signal Name
51J	L	-
52J	P	-

Connector No.	B75
Connector Name	WIRE TO WIRE
Connector Color	BROWN



Terminal No.	Color of Wire	Signal Name
1	P	-
2	L	-

ABMIA2478GB

A
B
C
D
E
F
G
H
I
J
K
L
N
O
P

CHG

CHARGING SYSTEM

< SYMPTOM DIAGNOSIS >

SYMPTOM DIAGNOSIS

CHARGING SYSTEM

Symptom Table

INFOID:000000006144190

Symptom	Reference
Battery discharged	Refer to CHG-5, "Work Flow" .
The charge warning lamp does not illuminate when the ignition switch is set to ON.	
The charge warning lamp does not turn OFF after the engine starts.	
The charging warning lamp turns ON when increasing the engine speed.	

GENERATOR

< REMOVAL AND INSTALLATION >

REMOVAL AND INSTALLATION

GENERATOR

Removal and Installation

INFOID:000000006144191

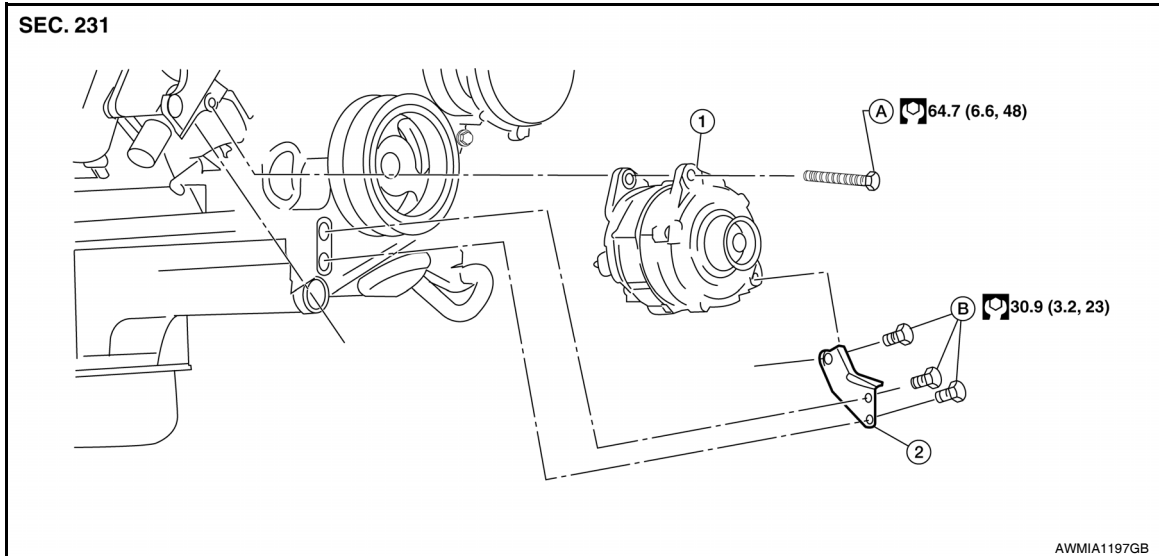

1. Generator
2. Lower bracket
A. Upper bolt
B. Lower bolts

REMOVAL

1. Disconnect the negative battery terminal. Refer to [PG-76, "Removal and Installation"](#).
2. Remove the fan shroud. Refer to [CO-15, "Removal and Installation"](#).
3. Remove the drive belt. Refer to [EM-13, "Removal and Installation"](#).
4. Remove lower bracket bolts and remove lower bracket, using power tools.
5. Remove the upper bolt, using power tools.
6. Disconnect the generator harness connectors.
7. Remove the generator.

INSTALLATION

Installation is in the reverse order of removal.

- Install the generator and check the tension of the drive belt. Refer to [EM-13, "Checking Drive Belts"](#).

CAUTION:

Tighten terminal nut carefully.

Terminal nut : 10.8 N·m (1.1 kg-m, 8 ft-lb)

GENERATOR

< SERVICE DATA AND SPECIFICATIONS (SDS)

SERVICE DATA AND SPECIFICATIONS (SDS)

GENERATOR

Generator

INFOID:000000006144192

Model*	TG15S179*
Manufacturer	Valeo
Nominal rating	14V-130A
Ground polarity	Negative
Minimum revolution under no-load	1,200 rpm
Hot output current (When 13.5 volts is applied)	More than 52A/1,500 rpm More than 82A/1,800 rpm More than 115A/2,500 rpm More than 130A/5,000 rpm
Regulated output voltage	13.5V @ 5,000 rpm @ 20°C
Adjustment range of power generation variable voltage control	11.4-15.6V

*Always check with the Parts Department for the latest parts information.