

A

SECTION STR

STR

STARTING SYSTEM

C

CONTENTS

D

PRECAUTION	2	DTC/CIRCUIT DIAGNOSIS	10	F
PRECAUTIONS	2	B TERMINAL CIRCUIT	10	
Precaution for Supplemental Restraint System (SRS) "AIR BAG" and "SEAT BELT PRE-TENSIONER"	2	Description	10	G
Precaution Necessary for Steering Wheel Rotation After Battery Disconnect	2	Diagnosis Procedure	10	
Precaution for Power Generation Variable Voltage Control System	3	S CONNECTOR CIRCUIT	11	H
PREPARATION	4	Description	11	
PREPARATION	4	Diagnosis Procedure	11	
Special Service Tool	4	WIRING DIAGRAM	12	I
Commercial Service Tool	4	STARTING SYSTEM	12	
BASIC INSPECTION	5	Wiring Diagram	12	J
DIAGNOSIS AND REPAIR WORKFLOW	5	SYMPTOM DIAGNOSIS	16	
Work Flow	5	STARTING SYSTEM	16	K
SYSTEM DESCRIPTION	8	Symptom Table	16	
STARTING SYSTEM	8	REMOVAL AND INSTALLATION	17	L
System Diagram	8	STARTER MOTOR	17	
System Description	8	Removal and Installation	17	
Component Parts Location	8	SERVICE DATA AND SPECIFICATIONS (SDS)	18	M
Component Description	9	STARTER MOTOR	18	N
		Starter	18	

O

P

PRECAUTIONS

< PRECAUTION >

PRECAUTION

PRECAUTIONS

Precaution for Supplemental Restraint System (SRS) "AIR BAG" and "SEAT BELT PRE-TENSIONER"

INFOID:000000006144151

The Supplemental Restraint System such as "AIR BAG" and "SEAT BELT PRE-TENSIONER", used along with a front seat belt, helps to reduce the risk or severity of injury to the driver and front passenger for certain types of collision. This system includes seat belt switch inputs and dual stage front air bag modules. The SRS system uses the seat belt switches to determine the front air bag deployment, and may only deploy one front air bag, depending on the severity of a collision and whether the front occupants are belted or unbelted. Information necessary to service the system safely is included in the SR and SB section of this Service Manual.

WARNING:

- To avoid rendering the SRS inoperative, which could increase the risk of personal injury or death in the event of a collision which would result in air bag inflation, all maintenance must be performed by an authorized NISSAN/INFINITI dealer.
- Improper maintenance, including incorrect removal and installation of the SRS, can lead to personal injury caused by unintentional activation of the system. For removal of Spiral Cable and Air Bag Module, see the SR section.
- Do not use electrical test equipment on any circuit related to the SRS unless instructed to in this Service Manual. SRS wiring harnesses can be identified by yellow and/or orange harnesses or harness connectors.

PRECAUTIONS WHEN USING POWER TOOLS (AIR OR ELECTRIC) AND HAMMERS

WARNING:

- When working near the Airbag Diagnosis Sensor Unit or other Airbag System sensors with the Ignition ON or engine running, DO NOT use air or electric power tools or strike near the sensor(s) with a hammer. Heavy vibration could activate the sensor(s) and deploy the air bag(s), possibly causing serious injury.
- When using air or electric power tools or hammers, always switch the Ignition OFF, disconnect the battery, and wait at least 3 minutes before performing any service.

Precaution Necessary for Steering Wheel Rotation After Battery Disconnect

INFOID:000000006144152

NOTE:

- This Procedure is applied only to models with Intelligent Key system and NATS (NISSAN ANTI-THEFT SYSTEM).
- Remove and install all control units after disconnecting both battery cables with the ignition knob in the "LOCK" position.
- Always use CONSULT-III to perform self-diagnosis as a part of each function inspection after finishing work. If DTC is detected, perform trouble diagnosis according to self-diagnostic results.

For models equipped with the Intelligent Key system and NATS, an electrically controlled steering lock mechanism is adopted on the key cylinder.

For this reason, if the battery is disconnected or if the battery is discharged, the steering wheel will lock and steering wheel rotation will become impossible.

If steering wheel rotation is required when battery power is interrupted, follow the procedure below before starting the repair operation.

OPERATION PROCEDURE

1. Connect both battery cables.

NOTE:

Supply power using jumper cables if battery is discharged.

2. Use the Intelligent Key or mechanical key to turn the ignition switch to the "ACC" position. At this time, the steering lock will be released.
3. Disconnect both battery cables. The steering lock will remain released and the steering wheel can be rotated.
4. Perform the necessary repair operation.

PRECAUTIONS

< PRECAUTION >

5. When the repair work is completed, return the ignition switch to the "LOCK" position before connecting the battery cables. (At this time, the steering lock mechanism will engage.)
6. Perform a self-diagnosis check of all control units using CONSULT-III.

Precaution for Power Generation Variable Voltage Control System

INFOID:000000006144153

CAUTION:

For this model, the battery current sensor that is installed to the negative battery cable measures the charging/discharging current of the battery and performs various engine controls. If an electrical component is connected directly to the negative battery terminal, the current flowing through that component will not be measured by the battery current sensor. This condition may cause a malfunction of the engine control system and battery discharge may occur. Do not connect an electrical component or ground wire directly to the battery terminal.

A

STR

C

D

E

F

G

H

I

J

K

L

M

N

O

P

PREPARATION

< PREPARATION >

PREPARATION

PREPARATION

Special Service Tool

INFOID:000000006144154

The actual shapes of Kent-Moore tools may differ from those of special service tools illustrated here.

Tool number (Kent Moore No.) Tool name	Description
— (—) Model GR-8 Multitasking Battery Diagnostic Station	Tests Batteries, starting and charging system. For operating instructions, refer to diagnostic station instruction manual.

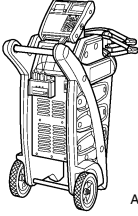

AWIA1239ZZ

Commercial Service Tool

INFOID:000000006144155

Tool name	Description
Power tool	Loosening bolts and nuts

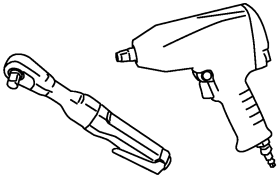

PBIC0190E

DIAGNOSIS AND REPAIR WORKFLOW

< BASIC INSPECTION >

BASIC INSPECTION

DIAGNOSIS AND REPAIR WORKFLOW

Work Flow

INFOID:000000006144156

STR

OVERALL SEQUENCE

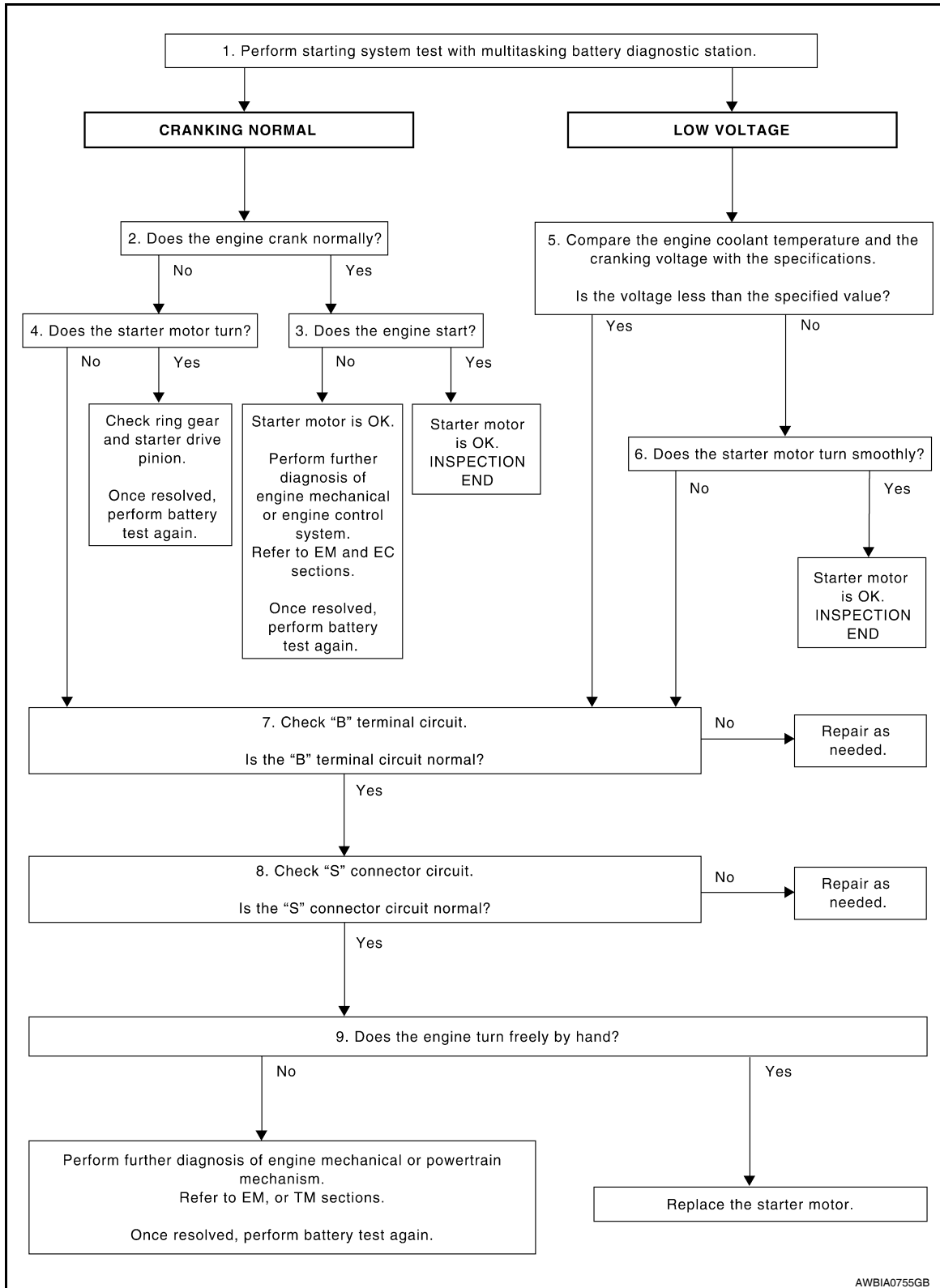

DETAILED FLOW

DIAGNOSIS AND REPAIR WORKFLOW

< BASIC INSPECTION >

NOTE:

To ensure a complete and thorough diagnosis, the battery, starter motor and generator test segments must be done as a set from start to finish.

1. DIAGNOSIS WITH MULTITASKING BATTERY DIAGNOSTIC STATION

Perform the starting system test with multitasking battery diagnostic station. For details and operating instructions, refer to diagnostic station instruction manual.

Test result

CRANKING NORMAL >> GO TO 2.

LOW VOLTAGE >> GO TO 5.

CHARGE BATTERY >> Perform the slow battery charging procedure. (Initial rate of charge is 10A for 12 hours.) Perform battery test again. Refer to diagnostic station instruction manual.

REPLACE BATTERY >> Before replacing battery, clean the battery cable clamps and battery posts. Perform battery test again. Refer to diagnostic station instruction manual. If second test result is "REPLACE BATTERY", then do so. Perform battery test again to confirm repair.

2. CRANKING CHECK

Check that the starter motor operates properly.

Does the engine crank normally?

YES >> GO TO 3.

NO >> GO TO 4.

3. ENGINE START CHECK

Check that the engine starts.

Does the engine start?

YES >> Starter motor is OK. Inspection end.

NO >> Perform further diagnosis of engine mechanical or engine control system. Refer to EM and EC sections. Once resolved, perform battery test again.

4. STARTER MOTOR ACTIVATION

Check that the starter motor operates.

Does the starter motor turn?

YES >> Check ring gear and starter motor drive pinion. Once resolved, perform battery test again.

NO >> GO TO 7.

5. COMPARISON BETWEEN ENGINE COOLANT AND CRANKING VOLTAGE

Compare the engine coolant temperature and verify the cranking voltage is within specification.

Minimum Specification of Cranking Voltage Referencing Coolant Temperature

Engine coolant temperature [°C (°F)]	Voltage [V]
-30 to -20 (-22 to -4)	8.6
-19 to -10 (-2 to 14)	9.1
-9 to 0 (16 to 32)	9.5
More than 1 (More than 34)	9.9

Is the voltage less than the specified value?

YES >> GO TO 7.

NO >> GO TO 6.

6. STARTER OPERATION

Check the starter operation.

Does the starter motor turn smoothly?

YES >> Starter motor is OK. Inspection End.

NO >> GO TO 7.

7. "B" TERMINAL CIRCUIT INSPECTION

Check "B" terminal circuit. Refer to [STR-10, "Diagnosis Procedure"](#).

Is "B" terminal circuit normal?

DIAGNOSIS AND REPAIR WORKFLOW

< BASIC INSPECTION >

- YES >> GO TO 8.
- NO >> Repair as needed.

A

8. "S" CONNECTOR CIRCUIT INSPECTION

Check "S" connector circuit. Refer to [STR-11. "Diagnosis Procedure"](#).

Is "S" connector circuit normal?

- YES >> GO TO 9.
- NO >> Repair as needed.

C

9. ENGINE ROTATION STATUS

Check that the engine can be rotated by hand.

Does the engine turn freely by hand?

- YES >> Replace starter motor. Refer to [STR-17. "Removal and Installation"](#).
- NO >> Perform further diagnosis of engine mechanical or powertrain mechanism. Refer to EM or TM sections. Once resolved, perform battery test again. Refer to diagnostic station instruction manual.

D

E

F

G

H

I

J

K

L

M

N

O

P

STR

STARTING SYSTEM

< SYSTEM DESCRIPTION >

SYSTEM DESCRIPTION

STARTING SYSTEM

System Diagram

INFOID:000000006144157

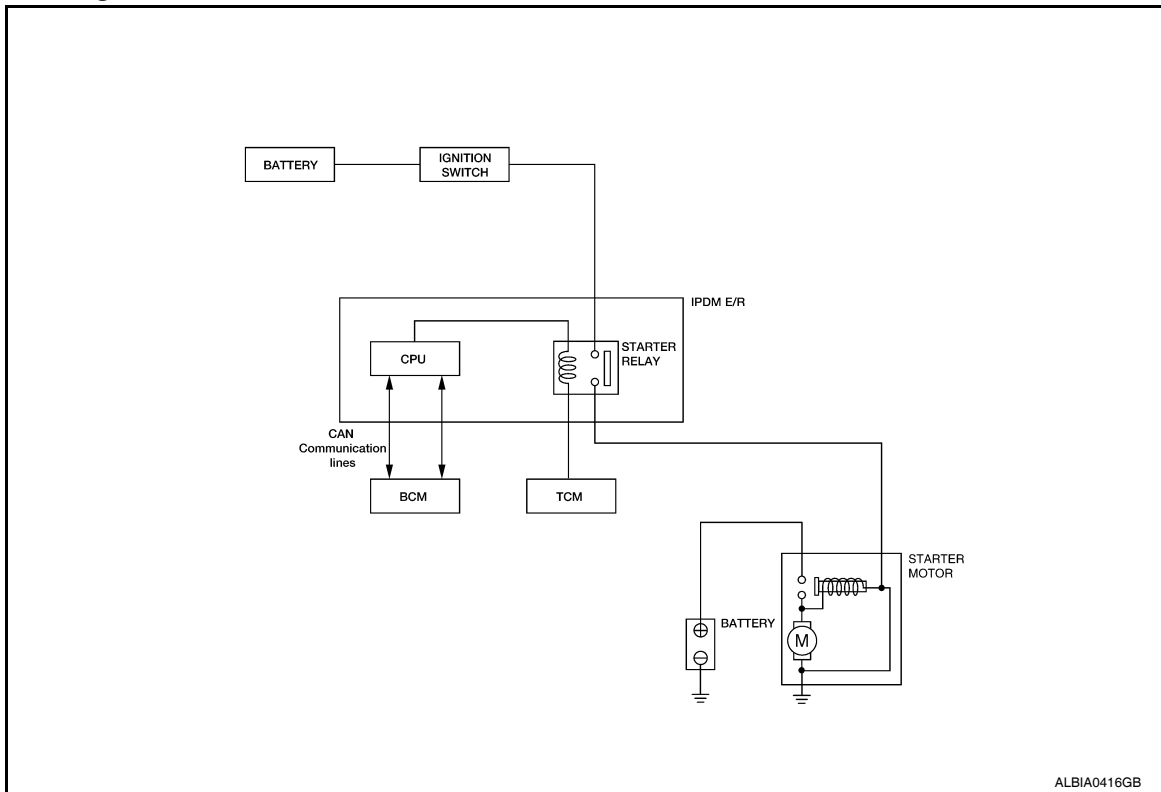

System Description

INFOID:000000006144158

The starter motor plunger closes and provides a closed circuit between the battery and the starter motor. The starter motor is grounded to the cylinder block. With power and ground supplied, the starter motor operates.

Component Parts Location

INFOID:000000006144159

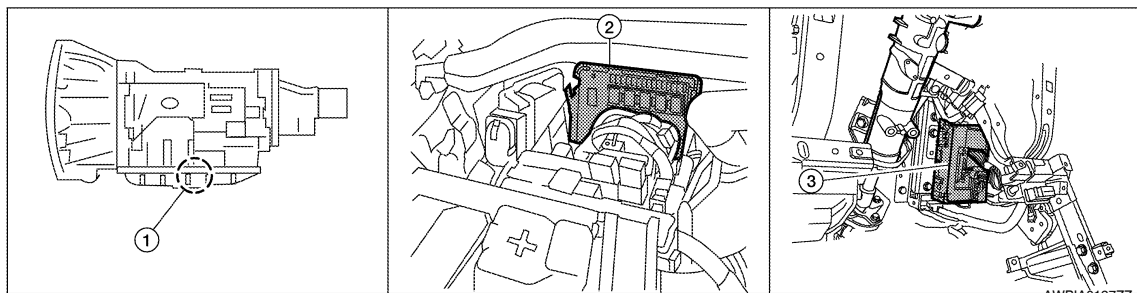

1. A/T assembly F9 (with built in TCM F502)

2. IPDM E/R E119, E120, E122, E124

3. BCM M18 (view with instrument panel lower LH panel removed)

STARTING SYSTEM

< SYSTEM DESCRIPTION >

Component Description

INFOID:000000006144160

Component part	Description
TCM	TCM supplies power to the starter relay inside the IPDM E/R when the selector lever is shifted to the P or N position.
BCM	BCM sends a starter request signal to the CPU of the IPDM E/R over the CAN communication lines.
IPDM E/R	CPU inside IPDM E/R operates the starter relay at the request of the BCM over the CAN communication lines.
Starter motor	The starter motor plunger closes and the motor is supplied with battery power, which in turn cranks the engine, when the "S" terminal is supplied with electric power.

A

STR

C

D

E

F

G

H

I

J

K

L

M

N

O

P

B TERMINAL CIRCUIT

< DTC/CIRCUIT DIAGNOSIS >

DTC/CIRCUIT DIAGNOSIS

B TERMINAL CIRCUIT

Description

INFOID:000000006144161

Terminal "1" (B) is constantly supplied with battery power.

Diagnosis Procedure

INFOID:000000006144162

Regarding Wiring Diagram information, refer to [STR-12. "Wiring Diagram"](#).

CAUTION:

Perform diagnosis under the condition that the engine cannot start by the following procedure.

1. Remove fuel pump fuse.
2. Crank or start the engine (where possible) until the fuel pressure is depleted.

1. CHECK TERMINAL 1 POWER SUPPLY VOLTAGE

1. Turn ignition switch OFF.
2. Make sure that starter motor connector F27 terminal 1 connection is clean and tight.
3. Check voltage between starter motor connector F27 terminal 1 and ground.

(+)		(-)	Voltage
Connector	Terminal		
F27	1	Ground	Battery voltage

Is there battery voltage present?

YES >> GO TO 2

NO >> Check harness between battery and starter motor for open circuit.

2. CHECK BATTERY CABLE (VOLTAGE DROP TEST)

1. Shift the transmission into park or neutral.
2. Check voltage between battery positive terminal and starter motor connector F27 terminal 1 while cranking the engine.

(+)		(-)	Condition	Voltage
Connector	Terminal			
F27	1	Battery (+) terminal	While cranking the engine	Less than 0.2V

Is the voltage drop less than 0.2V?

YES >> GO TO 3

NO >> Check harness between the battery and the starter motor for high resistance.

3. CHECK GROUND CIRCUIT STATUS (VOLTAGE DROP TEST)

Check voltage between starter motor case and battery negative terminal while cranking the engine.

(+)		(-)	Condition	Voltage
Starter motor case				
		Battery (-) terminal	While cranking the engine	Less than 0.2V

Is the voltage drop less than 0.2V?

YES >> Terminal 1 circuit is OK. Further inspection necessary. Refer to [STR-5. "Work Flow"](#).

NO >> Check the starter motor case to engine mounting for high resistance.

S CONNECTOR CIRCUIT

< DTC/CIRCUIT DIAGNOSIS >

S CONNECTOR CIRCUIT

Description

INFOID:000000006144163

Terminal "2" (S) is the power supply for the starter motor magnetic switch. Terminal 2 is supplied with power when the ignition switch is turned to the START position while the selector lever is in the P or N position.

STR

Diagnosis Procedure

INFOID:000000006144164

Regarding Wiring Diagram information, refer to [STR-12, "Wiring Diagram"](#).

CAUTION:

Perform diagnosis under the condition that engine cannot start by the following procedure.

1. Remove fuel pump fuse.
2. Crank or start the engine (where possible) until the fuel pressure is released.

1. CHECK STARTER MOTOR MAGNETIC SWITCH CIRCUIT

1. Turn ignition switch OFF.
2. Disconnect starter motor connector F28.
3. Shift transmission into park or neutral.
4. Check voltage between starter motor harness connector F28 terminal 2 and ground with the ignition switch in START.

(+)		(-)	Condition	Voltage
Connector	Terminal			
F28	2	Ground	Ignition switch in START	Battery voltage

Is battery voltage present?

- YES >> Magnetic switch circuit is OK. Further inspection necessary. Refer to [STR-5, "Work Flow"](#).
NO >> GO TO 2

2. CHECK CONNECTOR

1. Turn ignition switch OFF.
2. Check the IPDM E/R harness connector E120 and starter motor harness connector F28 for damage, bent pins and loose connections.

Is the inspection result normal?

- YES >> GO TO 3
NO >> Repair the terminal and connector.

3. CHECK HARNESS CONTINUITY (OPEN CIRCUIT)

1. Disconnect IPDM E/R connector E120 and starter motor connector F28.
2. Check continuity between starter motor harness connector F28 terminal 2 and IPDM E/R harness connector E120 terminal 19.

Connector	Terminal	Connector	Terminal	Continuity
F28	2	E120	19	Yes

3. Check continuity between starter motor harness connector F28 terminal 2 and ground.

Connector	Terminal	Ground	Continuity
F28	2		No

Are the continuity test results as specified?

- YES >> Further inspection necessary. Refer to [STR-5, "Work Flow"](#).
NO >> Repair the harness.

STARTING SYSTEM

< WIRING DIAGRAM >

WIRING DIAGRAM

STARTING SYSTEM

Wiring Diagram

INFOID:000000006418470

STARTING SYSTEM

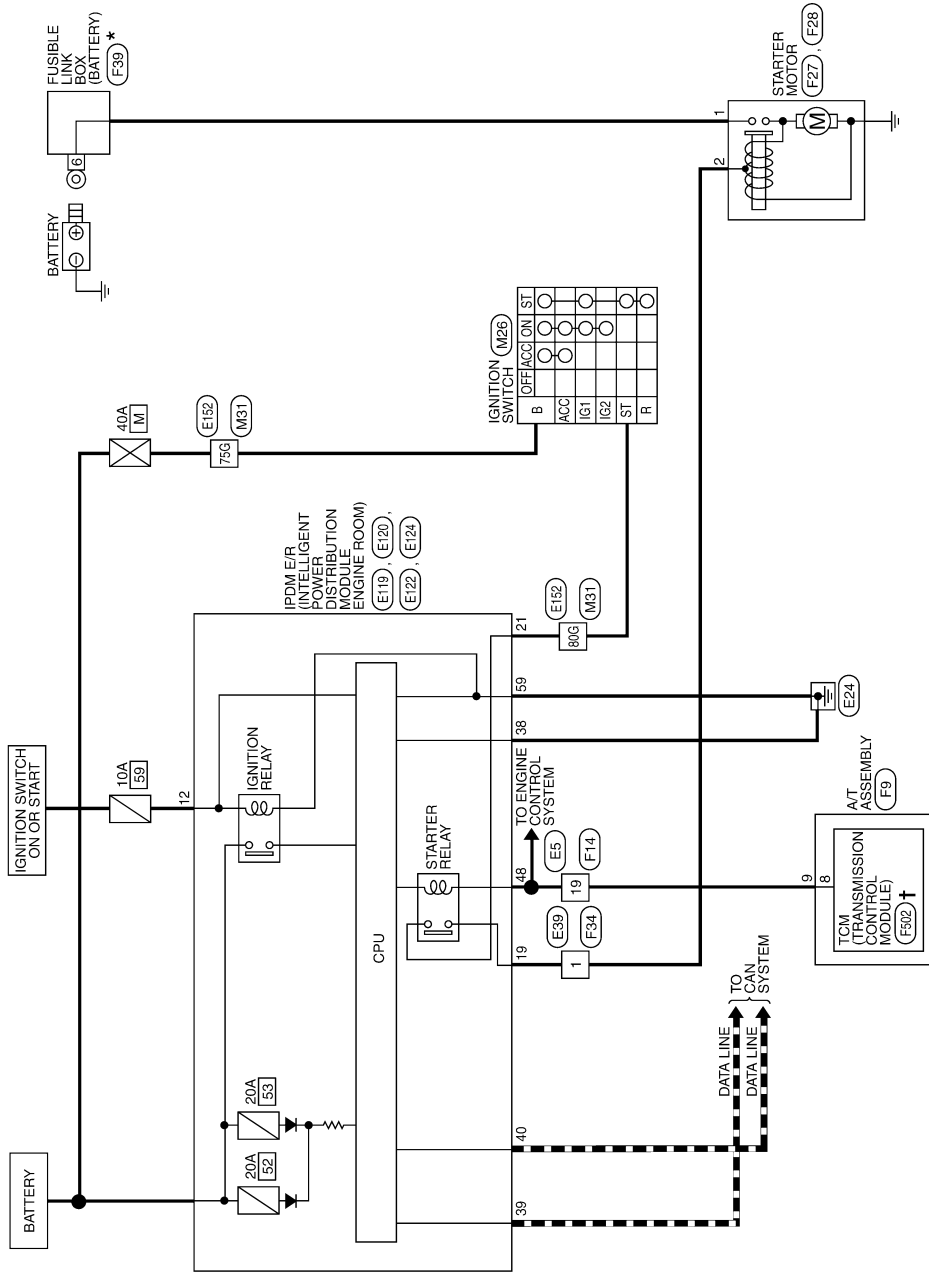

* : THIS CONNECTOR IS AN INTEGRAL PART OF THE FUSIBLE LINK BOX (BATTERY).
 † : THIS CONNECTOR IS NOT SHOWN IN "HARNESS LAYOUT" OF PG SECTION.

ABBWA0698GB

STARTING SYSTEM

< WIRING DIAGRAM >

STARTING SYSTEM CONNECTORS

Connector No.	M26
Connector Name	IGNITION SWITCH
Connector Color	WHITE



Terminal No.	Color of Wire	Signal Name
B	G	-
ST	BR	-

Connector No.	M31
Connector Name	WIRE TO WIRE
Connector Color	WHITE

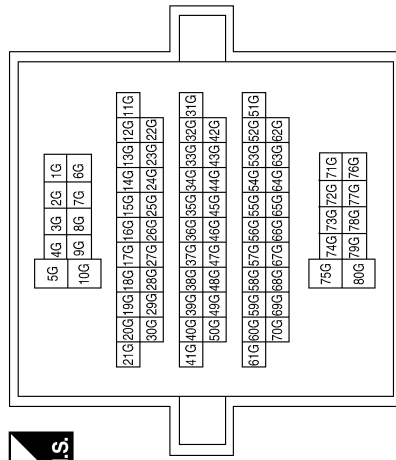

Terminal No.	Color of Wire	Signal Name
75G	G	-
80G	BR	-

Connector No.	E5
Connector Name	WIRE TO WIRE
Connector Color	WHITE

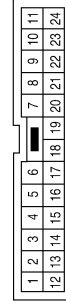

Terminal No.	Color of Wire	Signal Name
19	B/R	-

Connector No.	E39
Connector Name	WIRE TO WIRE
Connector Color	WHITE



Terminal No.	Color of Wire	Signal Name
1	W/R	-

Connector No.	E119
Connector Name	IPDM E/R (INTELLIGENT POWER DISTRIBUTION MODULE ENGINE ROOM)
Connector Color	WHITE



Terminal No.	Color of Wire	Signal Name
12	LAW	IGN SW(IG)

ABBIA0377GB

A
STR
C
D
E
F
G
H
I
J
K
L
M
N
O
P

STARTING SYSTEM

< WIRING DIAGRAM >

Connector No.	E124
Connector Name	IPDM E/R (INTELLIGENT POWER DISTRIBUTION MODULE ENGINE ROOM)
Connector Color	BLACK



59	58	57
62	61	60

Terminal No.	Color of Wire	Signal Name
59	B	GND (POWER)

Connector No.	E122
Connector Name	IPDM E/R (INTELLIGENT POWER DISTRIBUTION MODULE ENGINE ROOM)
Connector Color	WHITE



42	41	40	39	38	37
48	47	46	45	44	43

Terminal No.	Color of Wire	Signal Name
38	B	GND (SIGNAL)
39	L	CAN-H
40	P	CAN-L
48	B/R	RANGE SW

Connector No.	E120
Connector Name	IPDM E/R (INTELLIGENT POWER DISTRIBUTION MODULE ENGINE ROOM)
Connector Color	WHITE



21	20	19
24	23	22

Terminal No.	Color of Wire	Signal Name
19	W/R	STARTER MTR
21	BR	IGN SW(ST)

Connector No.	F9
Connector Name	A/T ASSEMBLY
Connector Color	GREEN



5	4	3	2	1
10	9	8	7	6

Terminal No.	Color of Wire	Signal Name
75G	G	-
80G	BR	-

Connector No.	E152
Connector Name	WIRE TO WIRE
Connector Color	WHITE

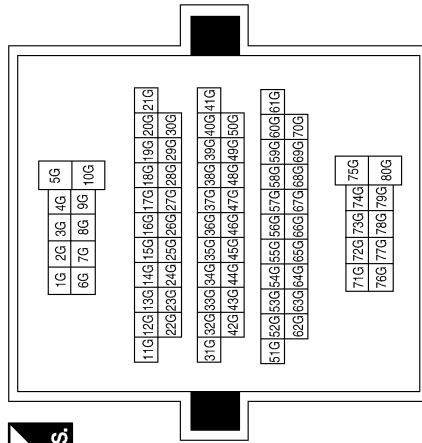

ABBIA0866GB

STARTING SYSTEM

< WIRING DIAGRAM >

Connector No.	F28
Connector Name	STARTER MOTOR
Connector Color	GRAY



Terminal No.	2	Color of Wire	B/R	Signal Name	-
--------------	---	---------------	-----	-------------	---

Connector No.	F27
Connector Name	STARTER MOTOR
Connector Color	-



Terminal No.	1	Color of Wire	W/R	Signal Name	-
--------------	---	---------------	-----	-------------	---

Connector No.	F14
Connector Name	WIRE TO WIRE
Connector Color	WHITE

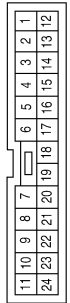

Terminal No.	19	Color of Wire	B/R	Signal Name	-
--------------	----	---------------	-----	-------------	---

Connector No.	F502
Connector Name	TCM (TRANSMISSION CONTROL MODULE)
Connector Color	GRAY

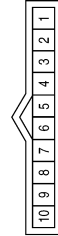

Terminal No.	8	Color of Wire	G	Signal Name	START-RLY
--------------	---	---------------	---	-------------	-----------

Connector No.	F34
Connector Name	WIRE TO WIRE
Connector Color	WHITE



Terminal No.	1	Color of Wire	W/R	Signal Name	-
--------------	---	---------------	-----	-------------	---

ABBIA0865GB

A
STR
C
D
E
F
G
H
I
J
K
L
M
N
O
P

STARTING SYSTEM

< SYMPTOM DIAGNOSIS >

SYMPTOM DIAGNOSIS

STARTING SYSTEM

Symptom Table

INFOID:000000006144166

Symptom	Reference
No normal cranking	Refer to STR-5, "Work Flow" .
Starter motor does not rotate	

STARTER MOTOR

< REMOVAL AND INSTALLATION >

REMOVAL AND INSTALLATION

STARTER MOTOR

Removal and Installation

INFOID:000000006144167

A

STR

REMOVAL

1. Remove the intake manifold. Refer to [EM-26. "Removal and Installation"](#).
2. Remove both the starter "S connector circuit" and "B terminal circuit" harness connectors.
3. Remove the two starter bolts, using power tools.
4. Remove the starter.

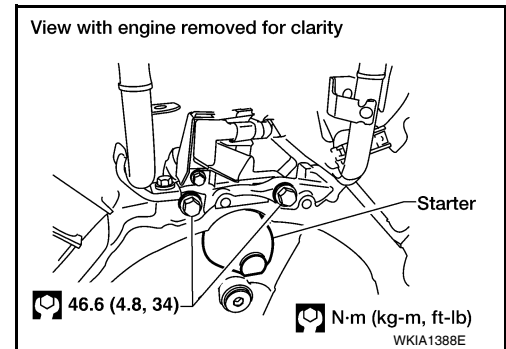

C

D

E

F

INSTALLATION

Installation is in the reverse order of removal.

CAUTION:

Tighten terminal nut carefully.

Terminal nut : 10.8 N·m (1.1 kg-m, 8 ft-lb)

G

H

I

J

K

L

M

N

O

P

STARTER MOTOR

< SERVICE DATA AND SPECIFICATIONS (SDS)

SERVICE DATA AND SPECIFICATIONS (SDS)

STARTER MOTOR

Starter

INFOID:000000006144168

Application		FFV models	Non-FFV models
Manufacturer		Mitsubishi	
Model number		M001T30571ZC*	M001T30671ZC*
Type		Reduction gear type	
System voltage		12V	
No-load	Terminal voltage	11V	
	Current	Less than 120A	
	Revolution	More than 3,220 rpm	

*Always check with parts department for the latest parts information.