

**WT**  
**SECTION**  
**ROAD WHEELS & TIRES**

A  
B  
C  
D

WT

**CONTENTS**

<p><b>BASIC INSPECTION</b> ..... 3</p> <p><b>DIAGNOSIS AND REPAIR WORKFLOW</b> ..... 3</p> <p style="padding-left: 20px;">Repair Work Flow .....3</p> <p><b>INSPECTION AND ADJUSTMENT</b> ..... 5</p> <p style="padding-left: 20px;">Preliminary Check .....5</p> <p style="padding-left: 20px;">Transmitter Wake Up Operation .....5</p> <p style="padding-left: 20px;">ID Registration Procedure .....6</p> <p><b>SYSTEM DESCRIPTION</b> ..... 8</p> <p><b>TPMS</b> ..... 8</p> <p style="padding-left: 20px;">System Diagram .....8</p> <p style="padding-left: 20px;">System Description .....8</p> <p style="padding-left: 20px;">System Component .....10</p> <p><b>DIAGNOSIS SYSTEM (BCM)</b> .....11</p> <p style="padding-left: 20px;">CONSULT-III Function (BCM - COMMON ITEM)... 11</p> <p style="padding-left: 20px;">CONSULT-III Function (BCM - AIR PRESSURE MONITOR) ..... 12</p> <p style="padding-left: 20px;">Self-Diagnosis (Without CONSULT-III) ..... 12</p> <p><b>DTC/CIRCUIT DIAGNOSIS</b> .....14</p> <p><b>C1708 - C1711 DATA FROM TRANSMITTER NOT BEING RECEIVED</b> .....14</p> <p style="padding-left: 20px;">Description ..... 14</p> <p style="padding-left: 20px;">DTC Logic ..... 14</p> <p style="padding-left: 20px;">Diagnosis Procedure ..... 14</p> <p style="padding-left: 20px;">Special Repair Requirement ..... 15</p> <p><b>C1712 - C1715, C1720 - C1723, C1724 - C1727 TRANSMITTER MALFUNCTION</b> .....16</p> <p style="padding-left: 20px;">Description ..... 16</p> <p style="padding-left: 20px;">DTC Logic ..... 16</p> <p style="padding-left: 20px;">Diagnosis Procedure ..... 16</p> <p style="padding-left: 20px;">Special Repair Requirement ..... 17</p> <p><b>C1716 - C1719 TRANSMITTER PRESSURE MALFUNCTION</b> .....18</p> <p style="padding-left: 20px;">Description ..... 18</p>	<p style="padding-left: 20px;">DTC Logic .....18</p> <p style="padding-left: 20px;">Diagnosis Procedure .....18</p> <p style="padding-left: 20px;">Special Repair Requirement .....18</p> <p><b>C1729 VEHICLE SPEED SIGNAL</b> .....19</p> <p style="padding-left: 20px;">Description .....19</p> <p style="padding-left: 20px;">DTC Logic .....19</p> <p style="padding-left: 20px;">Diagnosis Procedure .....19</p> <p style="padding-left: 20px;">Special Repair Requirement .....19</p> <p><b>C1735 IGNITION SIGNAL</b> .....20</p> <p style="padding-left: 20px;">Description .....20</p> <p style="padding-left: 20px;">DTC Logic .....20</p> <p style="padding-left: 20px;">Diagnosis Procedure .....20</p> <p style="padding-left: 20px;">Special Repair Requirement .....20</p> <p><b>ECU DIAGNOSIS INFORMATION</b> .....21</p> <p><b>BCM (BODY CONTROL MODULE)</b> .....21</p> <p style="padding-left: 20px;">Reference Value .....21</p> <p style="padding-left: 20px;">Terminal Layout .....24</p> <p style="padding-left: 20px;">Physical Values .....24</p> <p style="padding-left: 20px;">Self-Diagnosis (With CONSULT-III) .....29</p> <p style="padding-left: 20px;">Self-Diagnosis (Without CONSULT-III) .....30</p> <p><b>WIRING DIAGRAM</b> .....32</p> <p><b>TIRE PRESSURE MONITORING SYSTEM</b> .....32</p> <p style="padding-left: 20px;">Wiring Diagram .....32</p> <p><b>SYMPTOM DIAGNOSIS</b> .....37</p> <p><b>TPMS</b> .....37</p> <p style="padding-left: 20px;">Symptom Table .....37</p> <p><b>LOW TIRE PRESSURE WARNING LAMP DOES NOT TURN ON</b> .....38</p> <p style="padding-left: 20px;">Low Tire Pressure Warning Lamp Does Not Come On When Ignition Switch Is Turned On .....38</p> <p><b>LOW TIRE PRESSURE WARNING LAMP STAYS ON</b> .....39</p>
---	--

F  
G  
H  
I  
J  
K  
L  
M  
N  
O  
P

Low Tire Pressure Warning Lamp Stays On When Ignition Switch Is Turned On .....	39	Precaution Necessary for Steering Wheel Rotation After Battery Disconnect .....	45
<b>LOW TIRE PRESSURE WARNING LAMP BLINKS</b> .....	<b>40</b>	Precaution for Work .....	46
Low Tire Pressure Warning Lamp Flashes When Ignition Switch Is Turned On .....	40	<b>PREPARATION</b> .....	<b>47</b>
<b>HAZARD WARNING LAMPS FLASH</b> .....	<b>41</b>	<b>PREPARATION</b> .....	<b>47</b>
Hazard Warning Lamps Flash When Ignition Switch Is Turned On .....	41	Special Service Tool .....	47
<b>"TIRE PRESSURE" INFORMATION IN DISPLAY UNIT DOES NOT EXIST</b> .....	<b>42</b>	Commercial Service Tool .....	47
"TIRE PRESSURE" Information in Display Unit Does Not Exist .....	42	<b>PERIODIC MAINTENANCE</b> .....	<b>48</b>
<b>ID REGISTRATION CANNOT BE COMPLETED</b> .....	<b>43</b>	<b>WHEEL</b> .....	<b>48</b>
ID Registration Cannot Be Completed .....	43	Inspection .....	48
<b>NOISE, VIBRATION, AND HARSHNESS (NVH) TROUBLESHOOTING</b> .....	<b>44</b>	<b>REMOVAL AND INSTALLATION</b> .....	<b>49</b>
NVH Troubleshooting Chart .....	44	<b>WHEEL AND TIRE ASSEMBLY</b> .....	<b>49</b>
<b>PRECAUTION</b> .....	<b>45</b>	Balancing Wheels .....	49
<b>PRECAUTIONS</b> .....	<b>45</b>	Rotation .....	50
Precaution for Supplemental Restraint System (SRS) "AIR BAG" and "SEAT BELT PRE-TENSIONER" .....	45	<b>UNIT REMOVAL AND INSTALLATION</b> ....	<b>52</b>
		<b>TRANSMITTER</b> .....	<b>52</b>
		Transmitter (Pressure Sensor) .....	52
		<b>SERVICE DATA AND SPECIFICATIONS (SDS)</b> .....	<b>54</b>
		<b>SERVICE DATA AND SPECIFICATIONS (SDS)</b> .....	<b>54</b>
		Road Wheel .....	54
		Tire .....	54

# DIAGNOSIS AND REPAIR WORKFLOW

< BASIC INSPECTION >

## BASIC INSPECTION

### DIAGNOSIS AND REPAIR WORKFLOW

Repair Work Flow

INFOID:000000006147204

WORK FLOW

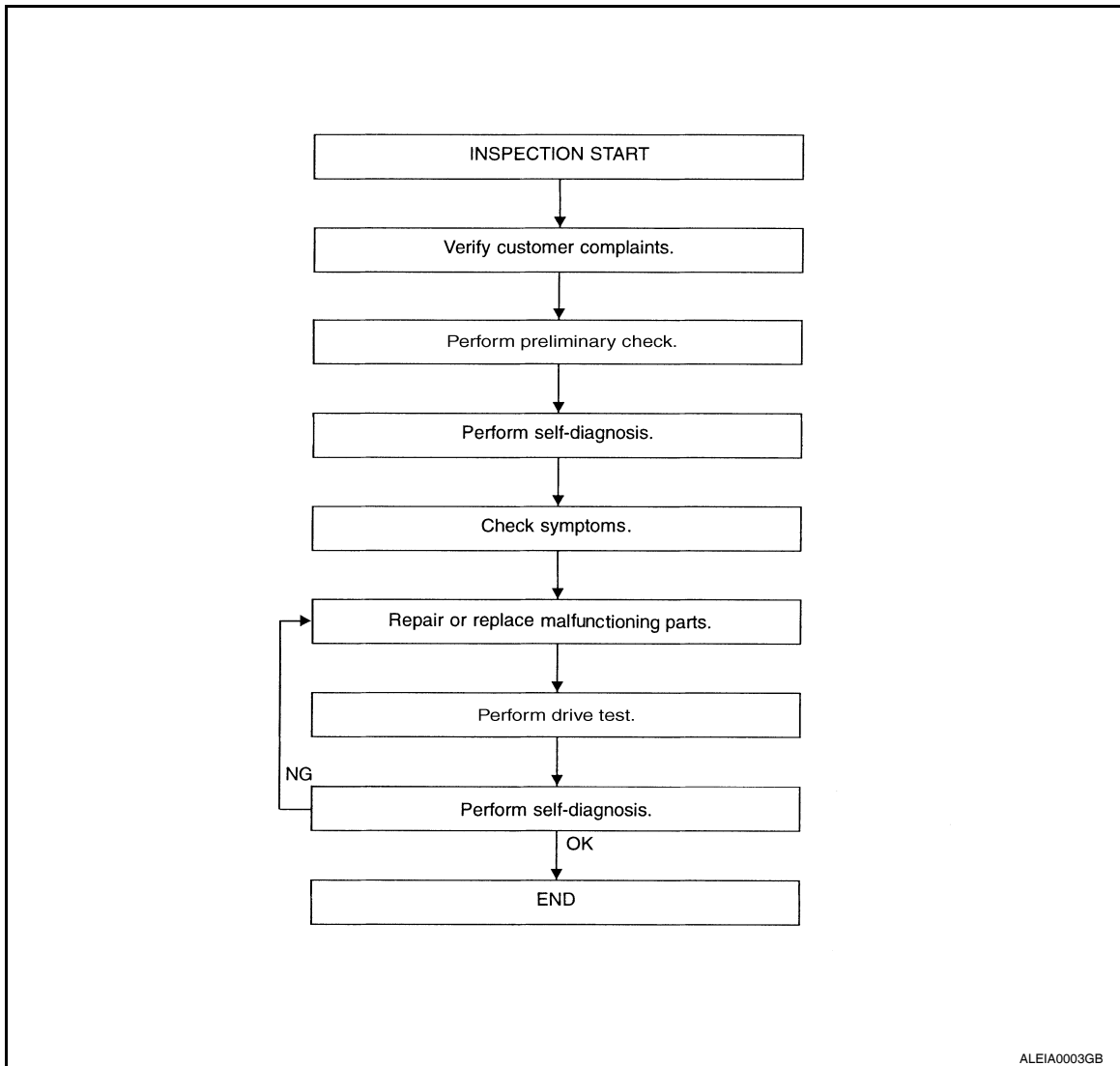

[WT-5. "Preliminary Check"](#)

[WT-29. "Self-Diagnosis \(With CONSULT-III\)"](#)

[WT-37. "Symptom Table"](#)

[WT-30. "Self-Diagnosis \(Without CONSULT-III\)"](#)

DETAILED FLOW

#### 1. CUSTOMER INFORMATION

Interview the customer to obtain detailed information about the symptom.

>> GO TO 2

#### 2. PRELIMINARY CHECK

Perform preliminary check. Refer to [WT-5. "Preliminary Check"](#).

>> GO TO 3

# DIAGNOSIS AND REPAIR WORKFLOW

< BASIC INSPECTION >

---

## 3.SELF-DIAGNOSIS

---

Perform SELF-DIAGNOSIS. Refer to [WT-29, "Self-Diagnosis \(With CONSULT-III\)"](#) (with CONSULT-III) or [WT-30, "Self-Diagnosis \(Without CONSULT-III\)"](#) (without CONSULT-III).

>> GO TO 4

## 4.SYMPTOM

---

Check for symptoms. Refer to [WT-37, "Symptom Table"](#).

>> GO TO 5

## 5.MALFUNCTIONING PARTS

---

Repair or replace the applicable parts.

>> GO TO 6

## 6.DRIVE TEST

---

1. Perform a drive test.
2. Check the low tire pressure warning lamp.

>> GO TO 7

## 7.SELF-DIAGNOSIS

---

Perform SELF-DIAGNOSIS. Refer to [WT-29, "Self-Diagnosis \(With CONSULT-III\)"](#) (with CONSULT-III) or [WT-30, "Self-Diagnosis \(Without CONSULT-III\)"](#) (without CONSULT-III).

Are any DTC's displayed?

- YES >> GO TO 5  
NO >> Inspection End

# INSPECTION AND ADJUSTMENT

< BASIC INSPECTION >

## INSPECTION AND ADJUSTMENT

### Preliminary Check

INFOID:000000006147205

#### 1. TIRE PRESSURE

Check all tire pressures. Refer to [WT-54, "Tire"](#).

Do tire pressures match specification?

YES >> GO TO 2.

NO >> Adjust tire pressures to specified value.

#### 2. LOW TIRE PRESSURE WARNING LAMP

Check low tire pressure warning lamp activation.

Does the low tire pressure warning lamp activate for one second when ignition switch is turned ON?

YES >> GO TO 3.

NO >> GO TO [WT-38, "Low Tire Pressure Warning Lamp Does Not Come On When Ignition Switch Is Turned On"](#).

#### 3. BCM CONNECTOR

1. Disconnect BCM harness connectors.
2. Check terminals for damage or loose connections.
3. Reconnect harness connectors.

Are BCM connectors damaged or loose?

YES >> Repair or replace damaged parts.

NO >> GO TO 4.

#### 4. TRANSMITTER ACTIVATION TOOL

Check battery in transmitter activation tool.

Is transmitter activation tool battery fully charged?

YES >> Perform self-diagnosis. Refer to [WT-29, "Self-Diagnosis \(With CONSULT-III\)"](#).

NO >> Replace battery in transmitter activation tool.

### Transmitter Wake Up Operation

INFOID:000000006147206

#### NOTE:

**This procedure must be done after replacement of a low tire pressure warning transmitter or BCM. New replacement transmitters are provided "asleep" and must first be "woken up" using Transmitter Activation Tool J-45295 before ID registration can be performed.**

1. Turn ignition switch ON. Push the transmitter activation tool against the tire near the front left transmitter. Press the button for 5 seconds. The hazard warning lamps flash per the following diagram.

**Tool number : (J-45295)**

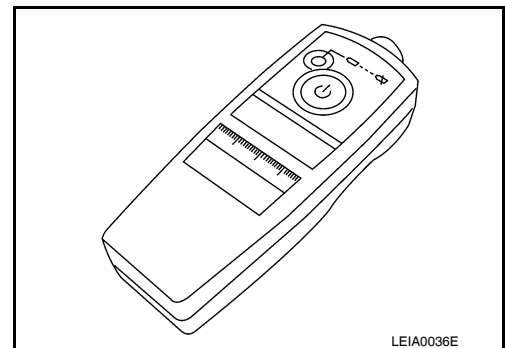

2. Repeat this procedure for each tire in the following order: FL, FR, RR, RL.

# INSPECTION AND ADJUSTMENT

## < BASIC INSPECTION >

- When the BCM finishes assigning each tire ID, the BCM flashes the hazard warning lamps and sends flashing indicator status by CAN according to the following time chart.

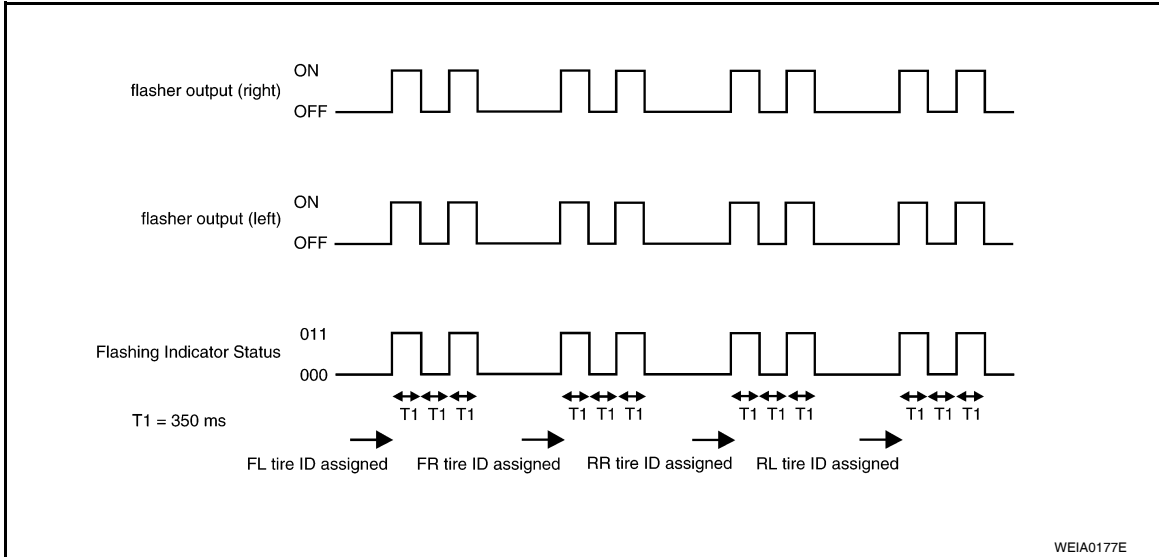

- After completing wake up of all transmitters, make sure low tire pressure warning lamp goes out.

## ID Registration Procedure

INFOID:000000006147207

### ID REGISTRATION WITH TRANSMITTER ACTIVATION TOOL

#### NOTE:

**This procedure must be done after replacement of a low tire pressure warning transmitter or BCM. New replacement transmitters are provided "asleep" and must first be "woken up" using Transmitter Activation Tool J-45295 before ID registration can be performed.**

- Connect CONSULT-III.
- Select "ID REGIST" under BCM.
- Push the transmitter activation tool against the tire near the front left transmitter. Press the button for 5 seconds.

**Tool number : (J-45295)**

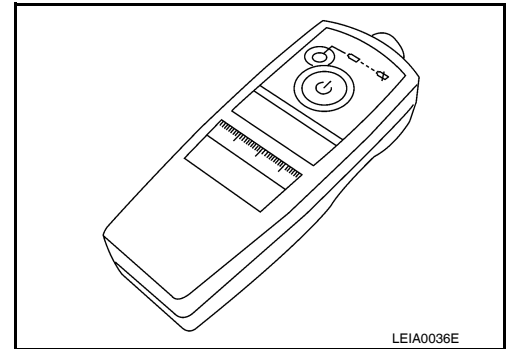

- Register the IDs in order from FR LH, FR RH, RR RH and RR LH. When ID registration of each wheel has been completed, the hazard warning lamps flash.

Step	Activation tire position	Hazard warning lamp	CONSULT-III
1	Front LH	2 times flashing	"YET" ↓ "DONE"
2	Front RH		
3	Rear RH		
4	Rear LH		

- After completing all ID registrations, press "END" to complete the procedure.

#### NOTE:

Be sure to register all of the IDs in order from FR LH, FR RH, RR RH, to RR LH, or the self-diagnostic results display will not function properly.

### ID REGISTRATION WITHOUT TRANSMITTER ACTIVATION TOOL

#### NOTE:

# INSPECTION AND ADJUSTMENT

## < BASIC INSPECTION >

**This procedure must be done after replacement of a low tire pressure warning transmitter or BCM. New replacement transmitters are provided "asleep" and must first be "woken up" using Transmitter Activation Tool J-45295 before ID registration can be performed.**

1. Connect CONSULT-III.
2. Select "ID REGIST" under BCM.
3. Adjust the tire pressures to the values shown in the table and drive the vehicle at 40 km/h (25 MPH) or more for a few minutes.

Tire position	Tire pressure kPa (kg/cm <sup>2</sup> , psi)
Front LH	250 (2.5, 36)
Front RH	230 (2.3, 33)
Rear RH	210 (2.1, 30)
Rear LH	190 (1.9, 27)

4. After completing all ID registrations, press "END" to complete the procedure.

Activation tire position	CONSULT-III
Front LH	"YET" ↓ "DONE"
Front RH	
Rear RH	
Rear LH	

5. Inflate all tires to proper pressure. Refer to [WT-54, "Tire"](#).

# TPMS

< SYSTEM DESCRIPTION >

## SYSTEM DESCRIPTION

### TPMS

#### System Diagram

INFOID:000000006147208

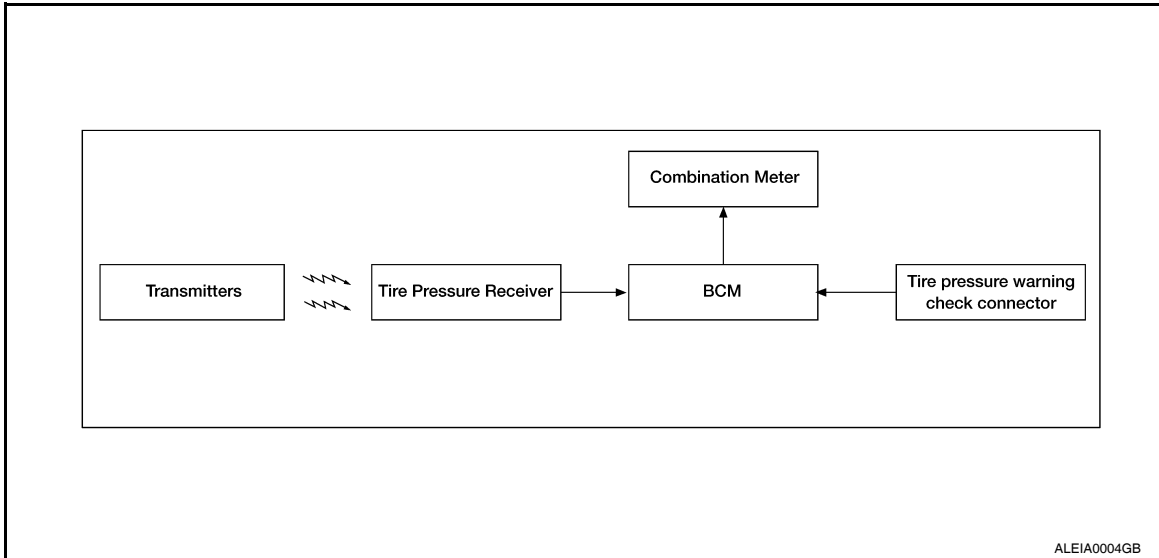

#### System Description

INFOID:000000006147209

#### BODY CONTROL MODULE (BCM)

The BCM is shown with the lower instrument panel LH removed. The BCM reads the air pressure signal received by the remote keyless entry receiver, and controls the low tire pressure warning lamp as shown below. It also has a self-diagnosis function to detect a system malfunction.

Condition	Low tire pressure warning lamp
System normal	On for 1 second after ignition ON
Tire less than 193 kPa (2.0 kg/cm <sup>2</sup> , 28 psi) [Flat tire]	ON
TPMS malfunction	After key ON, flashes once per second for 1 minute, then stays ON

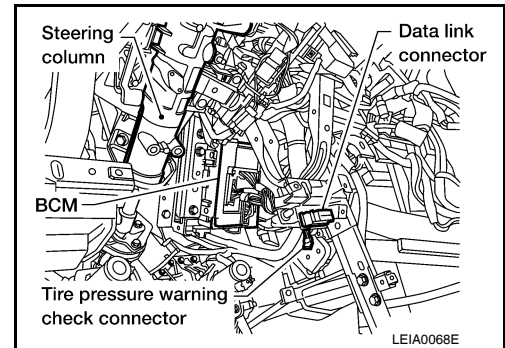

#### TRANSMITTER

A sensor-transmitter integrated with a valve is installed in each wheel, and transmits a detected air pressure signal in the form of a radio wave. The radio signal is received by the remote keyless entry receiver.

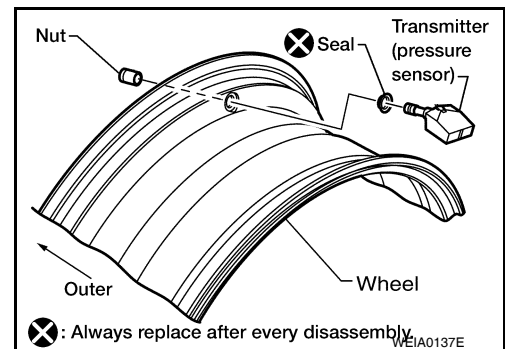

#### REMOTE KEYLESS ENTRY RECEIVER



# TPMS

## < SYSTEM DESCRIPTION >

The remote keyless entry receiver is shown with the instrument panel RH removed. The remote keyless entry receiver receives the air pressure signal transmitted by the transmitter in each wheel.

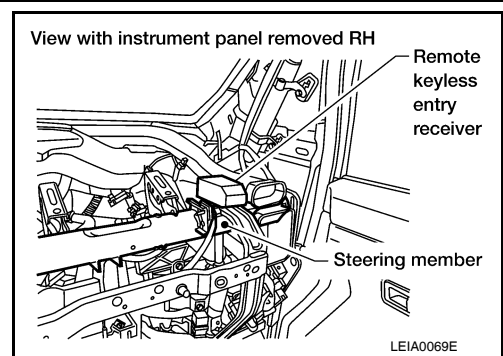

## COMBINATION METER

The combination meter receives tire pressure status from the BCM using CAN communication. When a low tire pressure condition is sensed by the BCM, the combination meter low tire pressure warning lamp is activated. A CHECK TIRE PRESSURE warning message will also be displayed in the vehicle information display. Refer to the Owner's Manual for additional information.

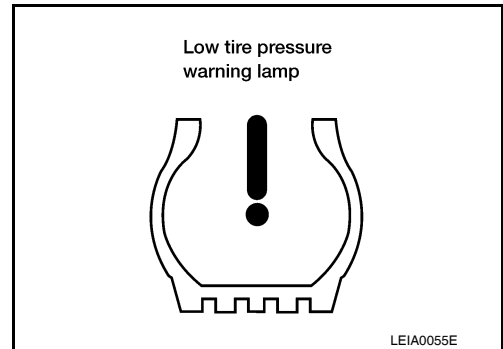

## TIRE PRESSURE WARNING CHECK CONNECTOR

The tire pressure warning check connector can be grounded in order to initiate self-diagnosis without a CONSULT-III. Refer to [WT-30](#), "[Self-Diagnosis \(Without CONSULT-III\)](#)". The tire pressure warning check connector is located behind the lower portion of the instrument panel LH.

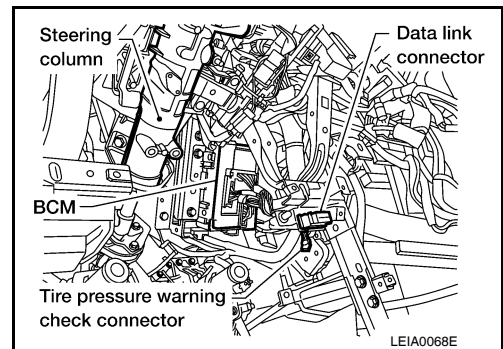

## DISPLAY UNIT

Displays the air pressure of each tire.

### NOTE:

After the ignition switch is turned on, the pressure values will not be displayed until the data of each wheel is received.

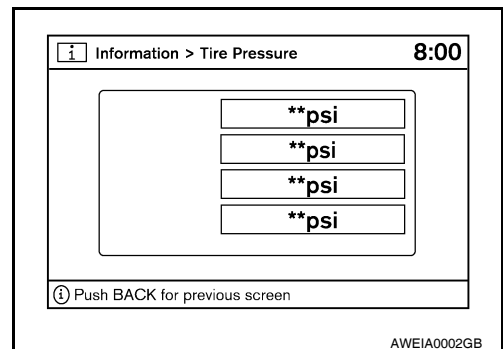

## DESCRIPTION

During driving, the tire pressure monitoring system receives the signal transmitted from the transmitter installed in each wheel, and turns on the low tire pressure warning lamp when the tire pressure becomes low. The control unit (BCM) for this system has pressure judgement and self-diagnosis functions.

## FUNCTION

When the tire pressure monitoring system detects low inflation pressure or an internal malfunction, the low tire pressure warning lamp in the combination meter comes on. The malfunction is indicated by the low tire pressure warning lamp flashing.

# TPMS

< SYSTEM DESCRIPTION >

## System Component

INFOID:000000006147210

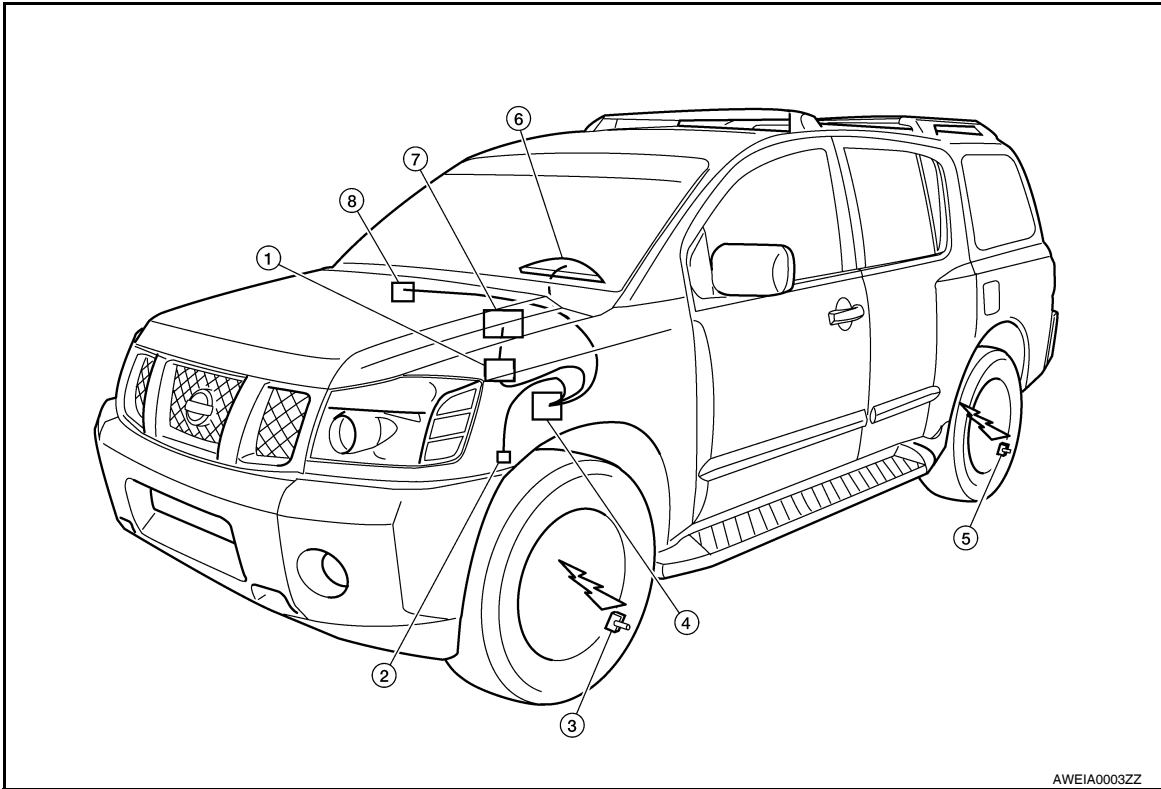

AWEIA0003ZZ

- |   |   |                          |
|---|---|--------------------------|
| 1. AV control unit M44, M46 (base audio system without NAVI)<br>AV control unit M166, M171 (Bose audio system without NAVI)<br>AV control unit M162, M165 (with NAVI) | 2. Tire pressure warning check connector M123 | 3. Transmitter           |
| 4. BCM M18, M20   | 5. Transmitter                                | 6. Combination meter M24 |
| 7. Display unit M93 (without NAVI)<br>Display unit M168 (with NAVI)   | 8. Remote keyless entry receiver M120         |                          |

# DIAGNOSIS SYSTEM (BCM)

< SYSTEM DESCRIPTION >

## DIAGNOSIS SYSTEM (BCM)

### CONSULT-III Function (BCM - COMMON ITEM)

INFOID:000000006751680

#### APPLICATION ITEM

CONSULT-III performs the following functions via CAN communication with BCM.

Direct Diagnostic Mode	Description
Ecu Identification	The BCM part number is displayed.
Self Diagnostic Result	The BCM self diagnostic results are displayed.
Data Monitor	The BCM input/output data is displayed in real time.
Active Test	The BCM activates outputs to test components.
Work support	The settings for BCM functions can be changed.
Configuration	<ul style="list-style-type: none"> <li>• The vehicle specification can be read and saved.</li> <li>• The vehicle specification can be written when replacing BCM.</li> </ul>
CAN Diag Support Mntr	The result of transmit/receive diagnosis of CAN communication is displayed.

#### SYSTEM APPLICATION

BCM can perform the following functions.

System	Sub System	Direct Diagnostic Mode						
		Ecu Identification	Self Diagnostic Result	Data Monitor	Active Test	Work support	Configuration	CAN Diag Support Mntr
Door lock	DOOR LOCK		×	×	×	×		
Rear window defogger	REAR DEFOGGER			×	×			
Warning chime	BUZZER			×	×			
Interior room lamp timer	INT LAMP			×	×	×		
Remote keyless entry system	MULTI REMOTE ENT			×	×	×		
Exterior lamp	HEADLAMP			×	×	×		
Wiper and washer	WIPER			×	×	×		
Turn signal and hazard warning lamps	FLASHER			×	×			
Air conditioner	AIR CONDITIONER			×				
Intelligent Key system	INTELLIGENT KEY			×				
Combination switch	COMB SW			×				
BCM	BCM	×	×			×	×	×
Immobilizer	IMMU		×	×	×			
Interior room lamp battery saver	BATTERY SAVER			×	×	×		
Back door open	TRUNK			×	×			
Vehicle security system	THEFT ALM			×	×	×		
RAP system	RETAINED PWR			×	×	×		
Signal buffer system	SIGNAL BUFFER			×	×			
TPMS	AIR PRESSURE MONITOR		×	×	×	×		
Panic alarm system	PANIC ALARM				×			

# DIAGNOSIS SYSTEM (BCM)

< SYSTEM DESCRIPTION >

## CONSULT-III Function (BCM - AIR PRESSURE MONITOR)

INFOID:000000006751679

### SELF DIAGNOSTIC RESULT

#### NOTE:

Before performing Self Diagnostic Result, be sure to register the ID, or else the actual malfunction may be different from that displayed on CONSULT-III.

Refer to [BCS-46. "DTC Index"](#).

### DATA MONITOR

Monitor Item	Condition	Specification
VEHICLE SPEED	Drive vehicle.	Vehicle speed (km/h or mph)
AIR PRESS FL	• Drive vehicle for a few minutes. or • Ignition switch ON and activation tool is transmitting activation signals.	Tire pressure (kPa, kg/cm <sup>2</sup> or psi).
AIR PRESS FR		
AIR PRESS RR		
AIR PRESS RL		
ID REGST FL1	Ignition switch ON.	Registration ID: Green. No registration: Red.
ID REGST FR1		
ID REGST RR1		
ID REGST RL1		
WARNING LAMP	Ignition switch ON.	Low tire pressure warning lamp on: ON. Low tire pressure warning lamp off: OFF.
BUZZER	Ignition switch ON.	Buzzer in combination meter on: ON. Buzzer in combination meter off: OFF.

### ACTIVE TEST

Test Item	Description
WARNING LAMP	This test is able to check tire pressure warning lamp operation [On/Off].
ID REGIST WARNING	This test is able to check ID regist warning chime operation [On/Off].
FLAT TIRE WARNING	This test is able to check flat tire warning chime operation [On/Off].
HORN	This test is able to check horn operation [On].
FLASHER	This test is able to check turn signal lamp operation [Off/LH/RH].

### WORK SUPPORT

Support Item	Description
ID REGIST	Refer to <a href="#">WT-6. "ID Registration Procedure"</a> .
ID READ	The registered ID number is displayed.

### Self-Diagnosis (Without CONSULT-III)

INFOID:000000006147212

#### SELF DIAGNOSTIC PROCEDURE (WITHOUT CONSULT-III)

1. Turn ignition switch ON.
2. Ground the tire pressure warning check connector to initiate self diagnosis.
3. Compare the flashing pattern with the flash code chart below.

# DIAGNOSIS SYSTEM (BCM)

## < SYSTEM DESCRIPTION >

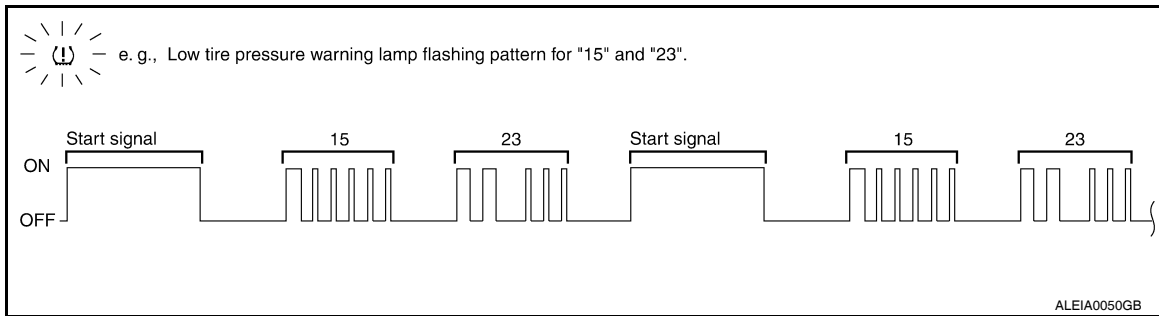

**NOTE:**

The system is normal when the low tire pressure warning lamp flashes 5 times and continues repeating. Self-diagnosis results are erased automatically by turning the ignition switch "OFF".

Flash Code	Malfunction part	Reference page
15 16 17 18	Tire pressure dropped below specified value. Refer to <a href="#">WT-8, "System Description"</a> .	—
21 22 23 24	Transmitter no data (FL) Transmitter no data (FR) Transmitter no data (RR) Transmitter no data (RL)	<a href="#">WT-14</a>
31 32 33 34	Transmitter checksum error (FL) Transmitter checksum error (FR) Transmitter checksum error (RR) Transmitter checksum error (RL)	<a href="#">WT-16</a>
35 36 37 38	Transmitter pressure data error (FL) Transmitter pressure data error (FR) Transmitter pressure data error (RR) Transmitter pressure data error (RL)	<a href="#">WT-18</a>
41 42 43 44	Transmitter function code error (FL) Transmitter function code error (FR) Transmitter function code error (RR) Transmitter function code error (RL)	<a href="#">WT-16</a>
45 46 47 48	Transmitter battery voltage low (FL) Transmitter battery voltage low (FR) Transmitter battery voltage low (RR) Transmitter battery voltage low (RL)	<a href="#">WT-16</a>
52	Vehicle speed signal	<a href="#">WT-19</a>
54	Vehicle ignition signal	<a href="#">WT-20</a>

A  
B  
C  
D  
WT  
F  
G  
H  
I  
J  
K  
L  
M  
N  
O  
P

# C1708 - C1711 DATA FROM TRANSMITTER NOT BEING RECEIVED

< DTC/CIRCUIT DIAGNOSIS >

## DTC/CIRCUIT DIAGNOSIS

### C1708 - C1711 DATA FROM TRANSMITTER NOT BEING RECEIVED

#### Description

INFOID:000000006147213

Tire pressure data for one or more transmitters is not being received by the BCM.

#### DTC Logic

INFOID:000000006147214

#### DTC DETECTION LOGIC

DTC	CONSULT-III	DTC detecting condition
C1708	[NO - DATA] - FL	Data from FL transmitter cannot be received.
C1709	[NO - DATA] - FR	Data from FR transmitter cannot be received.
C1710	[NO - DATA] - RR	Data from RR transmitter cannot be received.
C1711	[NO - DATA] - RL	Data from RL transmitter cannot be received.

#### DTC CONFIRMATION PROCEDURE

##### 1.ID REGISTRATION AND VEHICLE DRIVING

1. Carry out ID registration of all transmitters.
2. Drive at a speed of 40 km/h (25 MPH) or more for 3 minutes, and then drive the vehicle at any speed for 10 minutes.
3. Check all tire pressures with CONSULT-III within 5 minutes.

Does "DATA MONITOR ITEM" display tire pressure as normal without any warning lamp?

- YES >> Inspection End.  
NO >> Refer to [WT-14, "Diagnosis Procedure"](#).

#### Diagnosis Procedure

INFOID:000000006147215

MALFUNCTION CODE NO. 21, 22, 23 OR 24 (DTC C1708, C1709, C1710 OR C1711)

##### 1.CHECK BCM

Drive for several minutes. Check all tire pressures with CONSULT-III.

Are all tire pressures displayed as 0 kPa?

- YES >> GO TO 2  
NO >> GO TO 3

##### 2.CHECK TIRE PRESSURE RECEIVER CONNECTOR

Check tire pressure receiver connector for damage or loose connection.

Is tire pressure receiver connector damaged or loose?

- YES >> Repair or replace tire pressure receiver connector.  
NO >> Replace BCM, then GO TO 3. Refer to [BCS-56, "Removal and Installation"](#).

##### 3.PERFORM ID REGISTRATION

Carry out ID registration of all transmitters. Refer to [WT-6, "ID Registration Procedure"](#).

Is there a tire that cannot register ID?

- YES >> Replace malfunctioning transmitter, then GO TO 5. Refer to [WT-52, "Transmitter \(Pressure Sensor\)"](#).  
NO >> GO TO 4

##### 4.DRIVE VEHICLE

1. Drive at a speed of 40 km/h (25 MPH) or more for several minutes without stopping.
2. Check all tire pressures with CONSULT-III within 15 minutes after vehicle speed becomes 17 km/h (11 MPH).

Does "DATA MONITOR ITEM" display tire pressure as normal without any warning lamp?

# C1708 - C1711 DATA FROM TRANSMITTER NOT BEING RECEIVED

## < DTC/CIRCUIT DIAGNOSIS >

---

- YES >> Inspection End.
- NO >> GO TO 5

## 5.ID REGISTRATION AND VEHICLE DRIVING

---

1. Carry out ID registration of all transmitters.
2. Drive at a speed of 40 km/h (25 MPH) or more for 3 minutes, and then drive the vehicle at any speed for 10 minutes.
3. Check all tire pressures with CONSULT-III within 5 minutes.

Does "DATA MONITOR ITEM" display tire pressure as normal without any warning lamp?

- YES >> Inspection End.
- NO >> Proceed to the inspection applicable to DTC.

## Special Repair Requirement

INFOID:000000006147216

Perform preliminary check. Refer to [WT-5. "Preliminary Check"](#).

A  
B  
C  
D  
E  
F  
G  
H  
I  
J  
K  
L  
M  
N  
O  
P

WT

# C1712 - C1715, C1720 - C1723, C1724 - C1727 TRANSMITTER MALFUNCTION

< DTC/CIRCUIT DIAGNOSIS >

## C1712 - C1715, C1720 - C1723, C1724 - C1727 TRANSMITTER MALFUNCTION

### Description

INFOID:000000006147217

One or more transmitters are malfunctioning internally.

### DTC Logic

INFOID:000000006147218

### DTC DETECTION LOGIC

DTC	CONSULT-III	DTC detecting condition
C1712	[CHECKSUM - ERR] - FL	Checksum data from FL transmitter is malfunctioning.
C1713	[CHECKSUM - ERR] - FR	Checksum data from FR transmitter is malfunctioning.
C1714	[CHECKSUM - ERR] - RR	Checksum data from RR transmitter is malfunctioning.
C1715	[CHECKSUM - ERR] - RL	Checksum data from RL transmitter is malfunctioning.
C1720	[CODE - ERR] - FL	Function code data from FL transmitter is malfunctioning.
C1721	[CODE - ERR] - FR	Function code data from FR transmitter is malfunctioning.
C1722	[CODE - ERR] - RR	Function code data from RR transmitter is malfunctioning.
C1723	[CODE - ERR] - RL	Function code data from RL transmitter is malfunctioning.
C1724	[BATT - VOLT - LOW] - FL	Battery voltage of FL transmitter drops.
C1725	[BATT - VOLT - LOW] - FR	Battery voltage of FR transmitter drops.
C1726	[BATT - VOLT - LOW] - RR	Battery voltage of RR transmitter drops.
C1727	[BATT - VOLT - LOW] - RL	Battery voltage of RL transmitter drops.

### DTC CONFIRMATION PROCEDURE

#### 1. DRIVE VEHICLE

1. Drive at a speed of 40 km/h (25 MPH) or more for 3 minutes, and then drive the vehicle at any speed for 10 minutes.
2. Check all tire pressures with CONSULT-III within 5 minutes.

Does "DATA MONITOR ITEM" display tire pressure as normal without any warning lamp?

YES >> Inspection End.

NO >> Refer to [WT-16, "Diagnosis Procedure"](#).

### Diagnosis Procedure

INFOID:000000006147219

MALFUNCTION CODE NO. 31, 32, 33, 34, 41, 42, 43, 44, 45, 46, 47 OR 48 (DTC C1712, C1713, C1714, C1715, C1720, C1721, C1722, C1723, C1724, C1725, C1726 OR C1727)

#### 1. PERFORM ID REGISTRATION

1. Carry out ID registration of all transmitters. Refer to [WT-6, "ID Registration Procedure"](#).
2. Drive at a speed of 40 km/h (25 MPH) or more for 3 minutes, and then drive the vehicle at any speed for 10 minutes.

>> GO TO 2

#### 2. REPLACE TRANSMITTER

1. Check low tire pressure warning lamp again for flashing, replace malfunctioning transmitter. Refer to [WT-52, "Transmitter \(Pressure Sensor\)"](#).
2. Carry out ID registration of all transmitters.

Can ID registration of all transmitters be completed?

YES >> GO TO 3

NO >> GO TO [WT-14, "Diagnosis Procedure"](#).



# C1712 - C1715, C1720 - C1723, C1724 - C1727 TRANSMITTER MALFUNCTION

< DTC/CIRCUIT DIAGNOSIS >

## 3. DRIVE VEHICLE

1. Drive at a speed of 40 km/h (25 MPH) or more for 3 minutes, and then drive the vehicle at any speed for 10 minutes.
2. Check all tire pressures with CONSULT-III within 5 minutes.

Does "DATA MONITOR ITEM" display tire pressure as normal without any warning lamp?

YES >> Inspection End.

NO >> Replace malfunctioning transmitter, and perform Step 3 again.

### Special Repair Requirement

INFOID:000000006147220

Perform preliminary check. Refer to [WT-5, "Preliminary Check"](#).

A  
B  
C  
D  
E  
F  
G  
H  
I  
J  
K  
L  
M  
N  
O  
P

WT

# C1716 - C1719 TRANSMITTER PRESSURE MALFUNCTION

< DTC/CIRCUIT DIAGNOSIS >

## C1716 - C1719 TRANSMITTER PRESSURE MALFUNCTION

### Description

INFOID:000000006147221

Air pressure data from one or more transmitters is out of range.

### DTC Logic

INFOID:000000006147222

### DTC DETECTION LOGIC

DTC	CONSULT - III	DTC detecting condition
C1716	[PRESSDATA - ERR] FL	Air pressure data from FL transmitter is malfunctioning.
C1717	[PRESSDATA - ERR] FR	Air pressure data from FR transmitter is malfunctioning.
C1718	[PRESSDATA - ERR] RR	Air pressure data from RR transmitter is malfunctioning.
C1719	[PRESSDATA - ERR] RL	Air pressure data from RL transmitter is malfunctioning.

### DTC CONFIRMATION PROCEDURE

#### 1.ID REGISTRATION AND VEHICLE DRIVING

1. Carry out ID registration of all transmitters.
2. Drive at a speed of 40 km/h (25 MPH) or more for 3 minutes, and then drive the vehicle at any speed for 10 minutes.
3. Check all tire pressures with CONSULT-III within 5 minutes.

Does "DATA MONITOR ITEM" display tire pressure as normal without any warning lamp?

- YES >> Inspection End.  
NO >> Refer to [WT-18. "Diagnosis Procedure"](#).

### Diagnosis Procedure

INFOID:000000006147223

MALFUNCTION CODE NO. 35, 36, 37 OR 38 (DTC C1716, C1717, C1718 OR C1719)

#### 1.CHECK ALL TIRE PRESSURES

Check all tire pressures. Refer to [WT-54. "Tire"](#).

Are there any tires with pressure of 64 psi or more?

- YES >> Adjust tire pressure to specified value.  
NO >> GO TO 2

#### 2.ID REGISTRATION AND VEHICLE DRIVING

1. Carry out ID registration of all transmitters. Refer to [WT-6. "ID Registration Procedure"](#).
2. Drive at a speed of 40 km/h (25 MPH) or more for several minutes without stopping.
3. Check all tire pressures with CONSULT-III within 15 minutes after vehicle speed becomes 17 km/h (11 MPH).

Does "DATA MONITOR ITEM" display 64 psi or more?

- YES >> Replace transmitter. Refer to [WT-52. "Transmitter \(Pressure Sensor\)"](#). GO TO 3.  
NO >> GO TO 3

#### 3.ID REGISTRATION AND VEHICLE DRIVING

1. Carry out ID registration of all transmitters.
2. Drive at a speed of 40 km/h (25 MPH) or more for 3 minutes, and then drive the vehicle at any speed for 10 minutes.
3. Check all tire pressures with CONSULT-III within 5 minutes.

Does "DATA MONITOR ITEM" display tire pressure as normal without any warning lamp?

- YES >> Inspection End.  
NO >> Proceed to the inspection applicable to DTC.

### Special Repair Requirement

INFOID:000000006147224

Perform preliminary check. Refer to [WT-5. "Preliminary Check"](#).

# C1729 VEHICLE SPEED SIGNAL

< DTC/CIRCUIT DIAGNOSIS >

## C1729 VEHICLE SPEED SIGNAL

### Description

INFOID:000000006147225

The vehicle speed signal is not being detected by the BCM.

### DTC Logic

INFOID:000000006147226

### DTC DETECTION LOGIC

DTC	CONSULT - III	DTC detecting condition
C1729	VHCL SPEED SIG ERR	Vehicle speed signal is in error.

### DTC CONFIRMATION PROCEDURE

#### 1. CHECK SELF-DIAGNOSTIC RESULTS

1. On "SELECT DIAG MODE", select the "SELF-DIAG RESULT" screen.
2. Check display contents on "SELF DIAG RESULT" screen.

Is the "CAN COMM CIRCUIT" displayed in the self-diagnosis display?

YES >> Refer to [WT-19, "Diagnosis Procedure"](#).

NO >> Inspection End.

### Diagnosis Procedure

INFOID:000000006147227

### MALFUNCTION CODE NO. 52 (DTC C1729)

#### 1. CHECK SELF-DIAGNOSTIC RESULTS

1. On "SELECT DIAG MODE", select the "SELF-DIAG RESULT" screen.
2. Check display contents on "SELF DIAG RESULT" screen.

Is the "CAN COMM CIRCUIT" displayed in the self-diagnosis display?

YES >> Perform trouble diagnosis for CAN communication system. Refer to [LAN-14, "Trouble Diagnosis Flow Chart"](#).

NO >> Check combination meter. Refer to [MWI-27, "CONSULT-III Function \(METER/M&A\)"](#).

### Special Repair Requirement

INFOID:000000006147228

Perform preliminary check. Refer to [WT-5, "Preliminary Check"](#).

# C1735 IGNITION SIGNAL

< DTC/CIRCUIT DIAGNOSIS >

## C1735 IGNITION SIGNAL

### Description

INFOID:000000006147229

The BCM monitors the IGN ON signal on the CAN line and compares it to its direct IGN ON signal. When these two signals do not match, the BCM sets C1735.

### DTC Logic

INFOID:000000006147230

### DTC DETECTION LOGIC

DTC	CONSULT - III	DTC detecting condition
C1735	IGNITION SIGNAL LINE - BCM/TPMS	BCM has detected a mismatch between IGN ON signals.

### DTC CONFIRMATION PROCEDURE

#### 1. CHECK SELF-DIAGNOSTIC RESULTS

1. On SELECT DIAG MODE, select the SELF-DIAG RESULT screen.
2. Check display contents on SELF DIAG RESULT screen.

Is C1735 displayed in the self-diagnosis display?

- YES >> Refer to [WT-20, "Diagnosis Procedure"](#).  
NO >> Inspection End.

### Diagnosis Procedure

INFOID:000000006147231

### MALFUNCTION CODE NO. 54 (DTC C1735)

#### 1. CAN IGNITION SIGNAL

Check BCM IGN RLY signal with CONSULT-III. Refer to [BCS-37, "Reference Value"](#).

Are the inspection results normal with the ignition switch ON?

- YES >> GO TO 2.  
NO >> Check CAN system. Refer to [LAN-46, "CAN System Specification Chart"](#).

#### 2. BCM POWER SUPPLY

Check BCM power supply (ignition ON). Refer to [BCS-30, "Diagnosis Procedure"](#).

Is the power supply with the ignition switch ON normal?

- YES >> GO TO 3.  
NO >> Repair power supply as necessary.

#### 3. DRIVE VEHICLE

Clear DTC and then test drive the vehicle and check the low tire pressure warning lamp.

Does the vehicle operate without any low tire pressure warning lamp?

- YES >> Inspection End.  
NO >> Replace BCM. Refer to [BCS-56, "Removal and Installation"](#).

### Special Repair Requirement

INFOID:000000006147232

Perform preliminary check. Refer to [WT-5, "Preliminary Check"](#).

## BCM (BODY CONTROL MODULE)

< ECU DIAGNOSIS INFORMATION >

### ECU DIAGNOSIS INFORMATION

#### BCM (BODY CONTROL MODULE)

Reference Value

INFOID:0000000006624660

#### VALUES ON THE DIAGNOSIS TOOL

Monitor Item	Condition	Value/Status
ACC ON SW	Ignition switch OFF or ON	Off
	Ignition switch ACC	On
AIR COND SW	A/C switch OFF	Off
	A/C switch ON	On
AIR PRESS FL	Front left tire air pressure value	kPa, kg/cm <sup>2</sup> , psi
AIR PRESS FR	Front right tire air pressure value	kPa, kg/cm <sup>2</sup> , psi
AIR PRESS RL	Rear left tire air pressure value	kPa, kg/cm <sup>2</sup> , psi
AIR PRESS RR	Rear right tire air pressure value	kPa, kg/cm <sup>2</sup> , psi
AUTO LIGHT SW	Lighting switch OFF	Off
	Lighting switch AUTO	On
BACK DOOR SW	Back door closed	Off
	Back door opened	On
BRAKE SW	Brake pedal released	Off
	Brake pedal applied	On
BUCKLE SW	Seat belt buckle unfastened	Off
	Seat belt buckle fastened	On
BUZZER	Buzzer in combination meter OFF	Off
	Buzzer in combination meter ON	On
CARGO LAMP SW	Cargo lamp switch OFF	Off
	Cargo lamp switch ON	On
CDL LOCK SW	Door lock/unlock switch does not operate	Off
	Press door lock/unlock switch to the LOCK side	On
CDL UNLOCK SW	Door lock/unlock switch does not operate	Off
	Press door lock/unlock switch to the UNLOCK side	On
DOOR SW-AS	Front door RH closed	Off
	Front door RH opened	On
DOOR SW-DR	Front door LH closed	Off
	Front door LH opened	On
DOOR SW-RL	Rear door LH closed	Off
	Rear door LH opened	On
DOOR SW-RR	Rear door RH closed	Off
	Rear door RH opened	On
FAN ON SIG	Blower motor fan switch OFF	Off
	Blower motor fan switch ON	On
FR FOG SW	Front fog lamp switch OFF	Off
	Front fog lamp switch ON	On

## BCM (BODY CONTROL MODULE)

### < ECU DIAGNOSIS INFORMATION >

Monitor Item	Condition	Value/Status
FR WASHER SW	Front washer switch OFF	Off
	Front washer switch ON	On
FR WIPER LOW	Front wiper switch OFF	Off
	Front wiper switch LO	On
FR WIPER HI	Front wiper switch OFF	Off
	Front wiper switch HI	On
FR WIPER INT	Front wiper switch OFF	Off
	Front wiper switch INT	On
FR WIPER STOP	Any position other than front wiper stop position	Off
	Front wiper stop position	On
HAZARD SW	When hazard switch is not pressed	Off
	When hazard switch is pressed	On
HEAD LAMP SW1	Headlamp switch OFF	Off
	Headlamp switch 1st	On
HEAD LAMP SW2	Headlamp switch OFF	Off
	Headlamp switch 1st	On
HI BEAM SW	High beam switch OFF	Off
	High beam switch HI	On
ID REGST FL1	ID registration of front left tire incomplete	YET
	ID registration of front left tire complete	DONE
ID REGST FR1	ID registration of front right tire incomplete	YET
	ID registration of front right tire complete	DONE
ID REGST RL1	ID registration of rear left tire incomplete	YET
	ID registration of rear left tire complete	DONE
ID REGST RR1	ID registration of rear right tire incomplete	YET
	ID registration of rear right tire complete	DONE
IGN ON SW	Ignition switch OFF or ACC	Off
	Ignition switch ON	On
IGN SW CAN	Ignition switch OFF or ACC	Off
	Ignition switch ON	On
INT VOLUME	Wiper intermittent dial is in a dial position 1 - 7	1 - 7
I-KEY LOCK <sup>1</sup>	LOCK button of Intelligent Key is not pressed	Off
	LOCK button of Intelligent Key is pressed	On
I-KEY PANIC <sup>1</sup>	PANIC button of Intelligent Key is not pressed	Off
	PANIC button of Intelligent Key is pressed	On
I-KEY PW DWN <sup>1</sup>	UNLOCK button of Intelligent Key is not pressed	Off
	UNLOCK button of Intelligent Key is pressed for greater than 3 seconds and driver's window operating in DOWN direction	On
I-KEY UNLOCK <sup>1</sup>	UNLOCK button of Intelligent Key is not pressed	Off
	UNLOCK button of Intelligent Key is pressed	On
KEY CYL LK-SW	Door key cylinder LOCK position	Off
	Door key cylinder other than LOCK position	On
KEY CYL UN-SW	Door key cylinder UNLOCK position	Off
	Door key cylinder other than UNLOCK position	On

## BCM (BODY CONTROL MODULE)

### < ECU DIAGNOSIS INFORMATION >

Monitor Item	Condition	Value/Status	
KEY ON SW	Mechanical key is removed from key cylinder	Off	A
	Mechanical key is inserted to key cylinder	On	
KEYLESS LOCK <sup>2</sup>	LOCK button of key fob is not pressed	Off	B
	LOCK button of key fob is pressed	On	
KEYLESS PANIC <sup>2</sup>	PANIC button of key fob is not pressed	Off	C
	PANIC button of key fob is pressed	On	
KEYLESS UNLOCK <sup>2</sup>	UNLOCK button of key fob is not pressed	Off	D
	UNLOCK button of key fob is pressed	On	
LIGHT SW 1ST	Lighting switch OFF	Off	
	Lighting switch 1st	On	
OIL PRESS SW	<ul style="list-style-type: none"> <li>• Ignition switch OFF or ACC</li> <li>• Engine running</li> </ul>	Off	WT
	Ignition switch ON	On	
OPTICAL SENSOR	Bright outside of the vehicle	Close to 5V	F
	Dark outside of the vehicle	Close to 0V	
PASSING SW	Other than lighting switch PASS	Off	G
	Lighting switch PASS	On	
PUSH SW <sup>1</sup>	Return to ignition switch to LOCK position	Off	H
	Press ignition switch	On	
REAR DEF SW	Rear window defogger switch OFF	Off	
	Rear window defogger switch ON	On	I
RR WASHER SW	Rear washer switch OFF	Off	
	Rear washer switch ON	On	
RR WIPER INT	Rear wiper switch OFF	Off	J
	Rear wiper switch INT	On	
RR WIPER ON	Rear wiper switch OFF	Off	K
	Rear wiper switch ON	On	
RR WIPER STOP	Rear wiper stop position	Off	
	Other than rear wiper stop position	On	L
RR WIPER STP2	Rear wiper stop position	Off	
	Other than rear wiper stop position	On	
TURN SIGNAL L	Turn signal switch OFF	Off	M
	Turn signal switch LH	On	
TURN SIGNAL R	Turn signal switch OFF	Off	N
	Turn signal switch RH	On	
VEHICLE SPEED	While driving	Equivalent to speedometer reading	
WARNING LAMP	Low tire pressure warning lamp in combination meter OFF	Off	O
	Low tire pressure warning lamp in combination meter ON	On	

1: With Intelligent Key

2: With remote keyless entry system

# BCM (BODY CONTROL MODULE)

< ECU DIAGNOSIS INFORMATION >

## Terminal Layout

INFOID:000000006624661

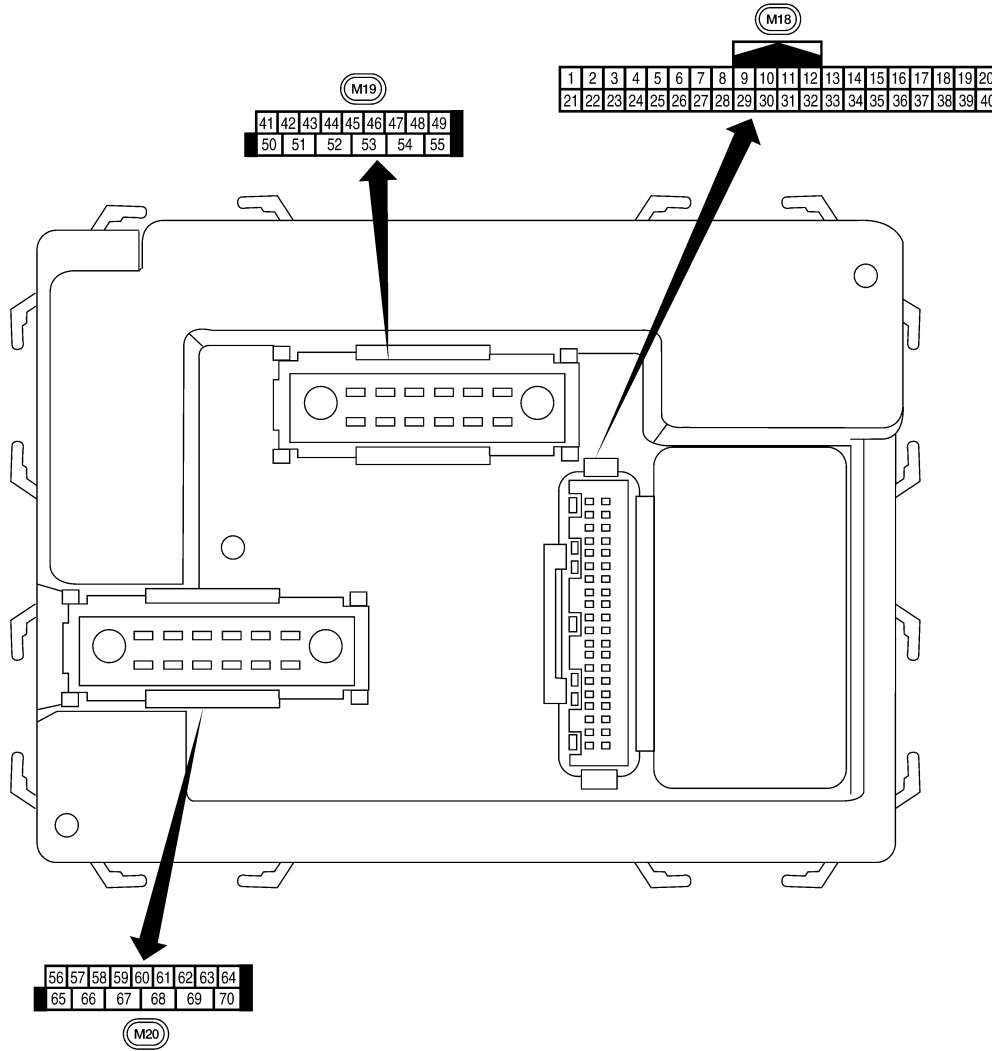

LIIA2443E



## Physical Values

INFOID:000000006624662

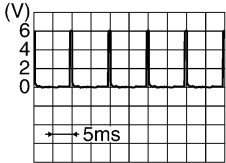

# BCM (BODY CONTROL MODULE)

## < ECU DIAGNOSIS INFORMATION >

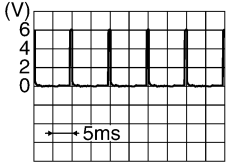
Terminal	Wire color	Signal name	Signal input/output	Measuring condition		Reference value or waveform (Approx.)
				Ignition switch	Operation or condition	
1	BR/W	Ignition keyhole illumination	Output	OFF	Door is locked (SW OFF)	Battery voltage
					Door is unlocked (SW ON)	0V
2	SB	Combination switch input 5	Input	ON	Lighting, turn, wiper OFF Wiper dial position 4	 <p style="text-align: right; font-size: small;">SKIA5291E</p>
3	G/Y	Combination switch input 4	Input	ON	Lighting, turn, wiper OFF Wiper dial position 4	 <p style="text-align: right; font-size: small;">SKIA5292E</p>
4	Y	Combination switch input 3	Input	ON	Lighting, turn, wiper OFF Wiper dial position 4	 <p style="text-align: right; font-size: small;">SKIA5291E</p>
5	G/B	Combination switch input 2	Input	ON	Lighting, turn, wiper OFF Wiper dial position 4	 <p style="text-align: right; font-size: small;">SKIA5292E</p>
6	V	Combination switch input 1				
9	GR/R	Rear window defogger switch	Input	ON	Rear window defogger switch ON	0V
					Rear window defogger switch OFF	5V
10	G	Hazard lamp flash	Input	OFF	ON (opening or closing)	0V
					OFF (other than above)	Battery voltage
11	O	Ignition switch (ACC or ON)	Input	ACC or ON	Ignition switch ACC or ON	Battery voltage
12	R/L	Front door switch RH	Input	OFF	ON (open)	0V
					OFF (closed)	Battery voltage
13	GR	Rear door switch RH	Input	OFF	ON (open)	0V
					OFF (closed)	Battery voltage
15	L/W	Tire pressure warning check connector	Input	OFF	—	5V
18	P	Remote keyless entry receiver and optical sensor (ground)	Output	OFF	—	0V

A

B

C

D

WT

F

G

H

I

J

K

L

M

N

O

P



# BCM (BODY CONTROL MODULE)

## < ECU DIAGNOSIS INFORMATION >

Terminal	Wire color	Signal name	Signal input/output	Measuring condition		Reference value or waveform (Approx.)
				Ignition switch	Operation or condition	
19	V/W	Remote keyless entry receiver (power supply)	Output	OFF	Ignition switch OFF	<p style="text-align: right;">LIA1893E</p>
20	G/W	Remote keyless entry receiver (signal)	Input	OFF	Stand-by (keyfob buttons released)	<p style="text-align: right;">LIA1894E</p>
					When remote keyless entry receiver receives signal from keyfob (keyfob buttons pressed)	<p style="text-align: right;">LIA1895E</p>
21	G	NATS antenna amp.	Input	OFF → ON	Ignition switch (OFF → ON)	Just after turning ignition switch ON: Pointer of tester should move for approx. 1 second, then return to battery voltage.
22	W/V	BUS	—	—	Ignition switch ON or power window timer operates	<p style="text-align: right;">PIIA2344E</p>
23	G/O	Security indicator lamp	Output	OFF	Goes OFF → illuminates (Every 2.4 seconds)	Battery voltage → 0V
25	BR	NATS antenna amp.	Input	OFF → ON	Ignition switch (OFF → ON)	Just after turning ignition switch ON: Pointer of tester should move for approx. 1 second, then return to battery voltage.
26	Y/L	Rear wiper auto stop switch 2	Input	ON	Rise up position (rear wiper arm on stopper)	0V
					A Position (full clockwise stop position)	0V
					Forward sweep (counterclockwise direction)	Fluctuating
					B Position (full counterclockwise stop position)	Battery voltage
					Reverse sweep (clockwise direction)	Fluctuating
27	W/R	Compressor ON signal	Input	ON	A/C switch OFF	5V
					A/C switch ON	0V

# BCM (BODY CONTROL MODULE)

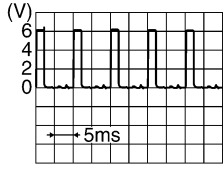
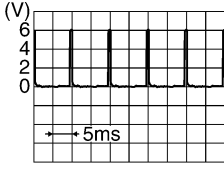
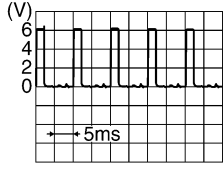
## < ECU DIAGNOSIS INFORMATION >

Terminal	Wire color	Signal name	Signal input/output	Measuring condition		Reference value or waveform (Approx.)
				Ignition switch	Operation or condition	
28	L/R	Front blower monitor	Input	ON	Front blower motor OFF	Battery voltage
					Front blower motor ON	0V
29	W/B	Hazard switch	Input	OFF	ON	0V
					OFF	5V
32	R/G	Combination switch output 5	Output	ON	Lighting, turn, wiper OFF Wiper dial position 4	 <p style="text-align: right; font-size: small;">SKIA5291E</p>
33	R/Y	Combination switch output 4	Output	ON	Lighting, turn, wiper OFF Wiper dial position 4	 <p style="text-align: right; font-size: small;">SKIA5292E</p>
34	L	Combination switch output 3	Output	ON	Lighting, turn, wiper OFF Wiper dial position 4	 <p style="text-align: right; font-size: small;">SKIA5291E</p>
35	O/B	Combination switch output 2	Output	ON	Lighting, turn, wiper OFF Wiper dial position 4	 <p style="text-align: right; font-size: small;">SKIA5292E</p>
36	R/W	Combination switch output 1				
37 <sup>1</sup>	B/R	Key switch and ignition knob switch	Input	OFF	Intelligent Key inserted	Battery voltage
					Intelligent Key inserted	0V
37 <sup>2</sup>	B/R	Key switch and key lock solenoid	Input	OFF	Key inserted	Battery voltage
					Key inserted	0V
38	W/L	Ignition switch (ON)	Input	ON	—	Battery voltage
39	L	CAN-H	—	—	—	—
40	P	CAN-L	—	—	—	—
42	GR	Glass hatch ajar switch	Input	ON	Glass hatch open	0
					Glass hatch closed	Battery
43	R/B	Back door switch (without power back door) or back door latch (door ajar switch) (with power back door)	Input	OFF	ON (open)	0V
					OFF (closed)	Battery voltage

A

B

C

D

WT

F

G

H

I

J

K

L

M

N

O

P

# BCM (BODY CONTROL MODULE)

## < ECU DIAGNOSIS INFORMATION >

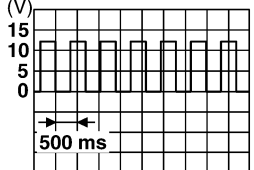
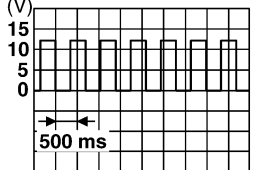
Terminal	Wire color	Signal name	Signal input/output	Measuring condition		Reference value or waveform (Approx.)
				Ignition switch	Operation or condition	
44	O	Rear wiper auto stop switch 1	Input	ON	Rise up position (rear wiper arm on stopper)	0V
					A Position (full clockwise stop position)	Battery voltage
					Forward sweep (counterclockwise direction)	Fluctuating
					B Position (full counterclockwise stop position)	0V
					Reverse sweep (clockwise direction)	Fluctuating
47	SB	Front door switch LH	Input	OFF	ON (open)	0V
					OFF (closed)	Battery voltage
48	R/Y	Rear door switch LH	Input	OFF	ON (open)	0V
					OFF (closed)	Battery voltage
49	R	Cargo lamp	Output	OFF	Any door open (ON)	0V
					All doors closed (OFF)	Battery voltage
51	G/Y	Trailer turn signal (right)	Output	ON	Turn right ON	 <p style="text-align: right; font-size: small;">SKIA3009J</p>
52	G/B	Trailer turn signal (left)	Output	ON	Turn left ON	 <p style="text-align: right; font-size: small;">SKIA3009J</p>
54	Y	Rear wiper output circuit 2	Input	ON	Rise up position (rear wiper arm on stopper)	0V
					A Position (full clockwise stop position)	0V
					Forward sweep (counterclockwise direction)	0V
					B Position (full counterclockwise stop position)	Battery voltage
					Reverse sweep (clockwise direction)	Battery voltage
55	SB	Rear wiper output circuit 1	Output	ON	OFF	0
					ON	Battery voltage
56	R/G	Battery saver output	Output	OFF	15 minutes after ignition switch is turned OFF	0V
				ON	—	Battery voltage
57	Y/R	Battery power supply	Input	OFF	—	Battery voltage

# BCM (BODY CONTROL MODULE)

## < ECU DIAGNOSIS INFORMATION >

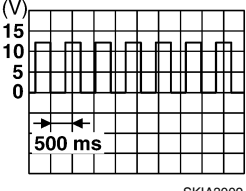
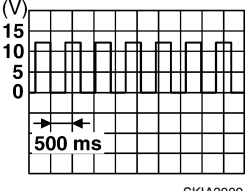
Terminal	Wire color	Signal name	Signal input/output	Measuring condition		Reference value or waveform (Approx.)
				Ignition switch	Operation or condition	
58	W/R	Optical sensor	Input	ON	When optical sensor is illuminated	3.1V or more
					When optical sensor is not illuminated	0.6V or less
59	G	Front door lock assembly LH actuator (unlock)	Output	OFF	OFF (neutral)	0V
					ON (unlock)	Battery voltage
60	G/B	Turn signal (left)	Output	ON	Turn left ON	
61	G/Y	Turn signal (right)	Output	ON	Turn right ON	
62	R/W	Step lamp LH and RH	Output	OFF	ON (any door open)	0V
					OFF (all doors closed)	Battery voltage
63	L	Interior room/map lamp	Output	OFF	Any door switch ON (open)	0V
					OFF (closed)	Battery voltage
65	V	All door lock actuators (lock)	Output	OFF	OFF (neutral)	0V
					ON (lock)	Battery voltage
66	G/Y	Front door lock actuator RH, rear door lock actuators LH/RH and back door lock actuator (unlock)	Output	OFF	OFF (neutral)	0V
					ON (unlock)	Battery voltage
67	B	Ground	Input	ON	—	0V
68	W/L	Power window power supply (RAP)	Output	—	Ignition switch ON	Battery voltage
					Within 45 seconds after ignition switch OFF	Battery voltage
					More than 45 seconds after ignition switch OFF	0V
					When front door LH or RH is open or power window timer operates	0V
69	W/R	Power window power supply	Output	—	—	Battery voltage
70	W/B	Battery power supply	Input	OFF	—	Battery voltage

1: With Intelligent Key system

2: With remote keyless entry system

## Self-Diagnosis (With CONSULT-III)

INFOID:000000006147237

### FUNCTION

# BCM (BODY CONTROL MODULE)

## < ECU DIAGNOSIS INFORMATION >

### Self-Diagnostic Results Mode

Diagnostic item	Diagnostic item is detected when ...	Reference page
LOW - PRESSURE - FL [C1704] LOW - PRESSURE - FR [C1705] LOW - PRESSURE - RR [C1706] LOW - PRESSURE - RL [C1707]	Tire pressures dropped below specified value. Refer to <a href="#">WT-8</a> . <a href="#">"System Description"</a> .	—
[NO-DATA] - FL [C1708] [NO-DATA] - FR [C1709] [NO-DATA] - RR [C1710] [NO-DATA] - RL [C1711]	Data from FL transmitter cannot be received. Data from FR transmitter cannot be received. Data from RR transmitter cannot be received. Data from RL transmitter cannot be received.	<a href="#">WT-14</a>
[CHECKSUM- ERR] - FL [C1712] [CHECKSUM- ERR] - FR [C1713] [CHECKSUM- ERR] - RR [C1714] [CHECKSUM- ERR] - RL [C1715]	Checksum data from FL transmitter is malfunctioning. Checksum data from FR transmitter is malfunctioning. Checksum data from RR transmitter is malfunctioning. Checksum data from RL transmitter is malfunctioning.	<a href="#">WT-16</a>
[PRESSDATA- ERR] - FL [C1716] [PRESSDATA- ERR] - FR [C1717] [PRESSDATA- ERR] - RR [C1718] [PRESSDATA- ERR] - RL [C1719]	Air pressure data from FL transmitter is malfunctioning. Air pressure data from FR transmitter is malfunctioning. Air pressure data from RR transmitter is malfunctioning. Air pressure data from RL transmitter is malfunctioning.	<a href="#">WT-18</a>
[CODE- ERR] - FL [C1720] [CODE- ERR] - FR [C1721] [CODE- ERR] - RR [C1722] [CODE- ERR] - RL [C1723]	Function code data from FL transmitter is malfunctioning. Function code data from FR transmitter is malfunctioning. Function code data from RR transmitter is malfunctioning. Function code data from RL transmitter is malfunctioning.	<a href="#">WT-16</a>
[BATT - VOLT - LOW] - FL [C1724] [BATT - VOLT - LOW] - FR [C1725] [BATT - VOLT - LOW] - RR [C1726] [BATT - VOLT - LOW] - RL [C1727]	Battery voltage of FL transmitter drops. Battery voltage of FR transmitter drops. Battery voltage of RR transmitter drops. Battery voltage of RL transmitter drops.	<a href="#">WT-16</a>
VHCL_SPEED_SIG_ERR [C1729]	Vehicle speed signal is in error.	<a href="#">WT-19</a>
IGN_CIRCUIT_OPEN [C1735]	Vehicle ignition signal is in error.	<a href="#">WT-20</a>

#### NOTE:

Before performing the self-diagnosis, be sure to register the ID or else the actual malfunction location may be different from that displayed on CONSULT-III.

### Self-Diagnosis (Without CONSULT-III)

INFOID:000000006147238

#### SELF DIAGNOSTIC PROCEDURE (WITHOUT CONSULT-III)

1. Turn ignition switch ON.
2. Ground the tire pressure warning check connector to initiate self diagnosis.
3. Compare the flashing pattern with the flash code chart below.

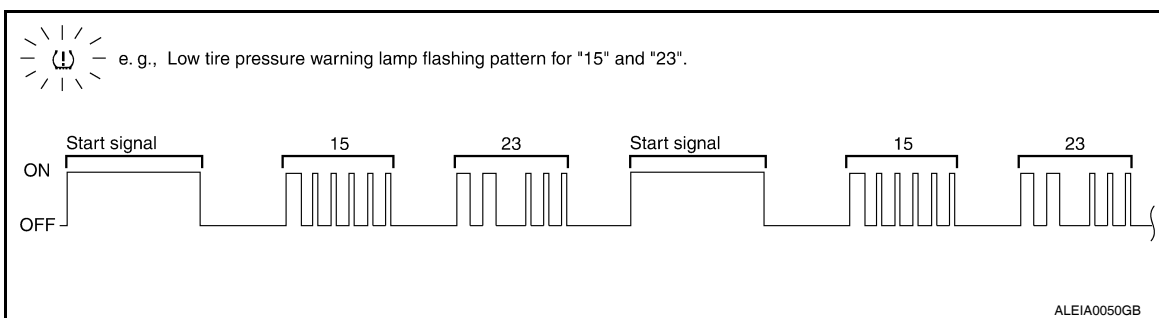

#### NOTE:

The system is normal when the low tire pressure warning lamp flashes 5 times and continues repeating. Self-diagnosis results are erased automatically by turning the ignition switch "OFF".

## BCM (BODY CONTROL MODULE)

< ECU DIAGNOSIS INFORMATION >

Flash Code	Malfunction part	Reference page
15 16 17 18	Tire pressure dropped below specified value. Refer to <a href="#">WT-8, "System Description"</a> .	—
21 22 23 24	Transmitter no data (FL) Transmitter no data (FR) Transmitter no data (RR) Transmitter no data (RL)	<a href="#">WT-14</a>
31 32 33 34	Transmitter checksum error (FL) Transmitter checksum error (FR) Transmitter checksum error (RR) Transmitter checksum error (RL)	<a href="#">WT-16</a>
35 36 37 38	Transmitter pressure data error (FL) Transmitter pressure data error (FR) Transmitter pressure data error (RR) Transmitter pressure data error (RL)	<a href="#">WT-18</a>
41 42 43 44	Transmitter function code error (FL) Transmitter function code error (FR) Transmitter function code error (RR) Transmitter function code error (RL)	<a href="#">WT-16</a>
45 46 47 48	Transmitter battery voltage low (FL) Transmitter battery voltage low (FR) Transmitter battery voltage low (RR) Transmitter battery voltage low (RL)	<a href="#">WT-16</a>
52	Vehicle speed signal	<a href="#">WT-19</a>
54	Vehicle ignition signal	<a href="#">WT-20</a>

A  
B  
C  
D  
WT  
F  
G  
H  
I  
J  
K  
L  
M  
N  
O  
P

# TIRE PRESSURE MONITORING SYSTEM

< WIRING DIAGRAM >

## WIRING DIAGRAM

### TIRE PRESSURE MONITORING SYSTEM

#### Wiring Diagram

INFOID:000000006418480

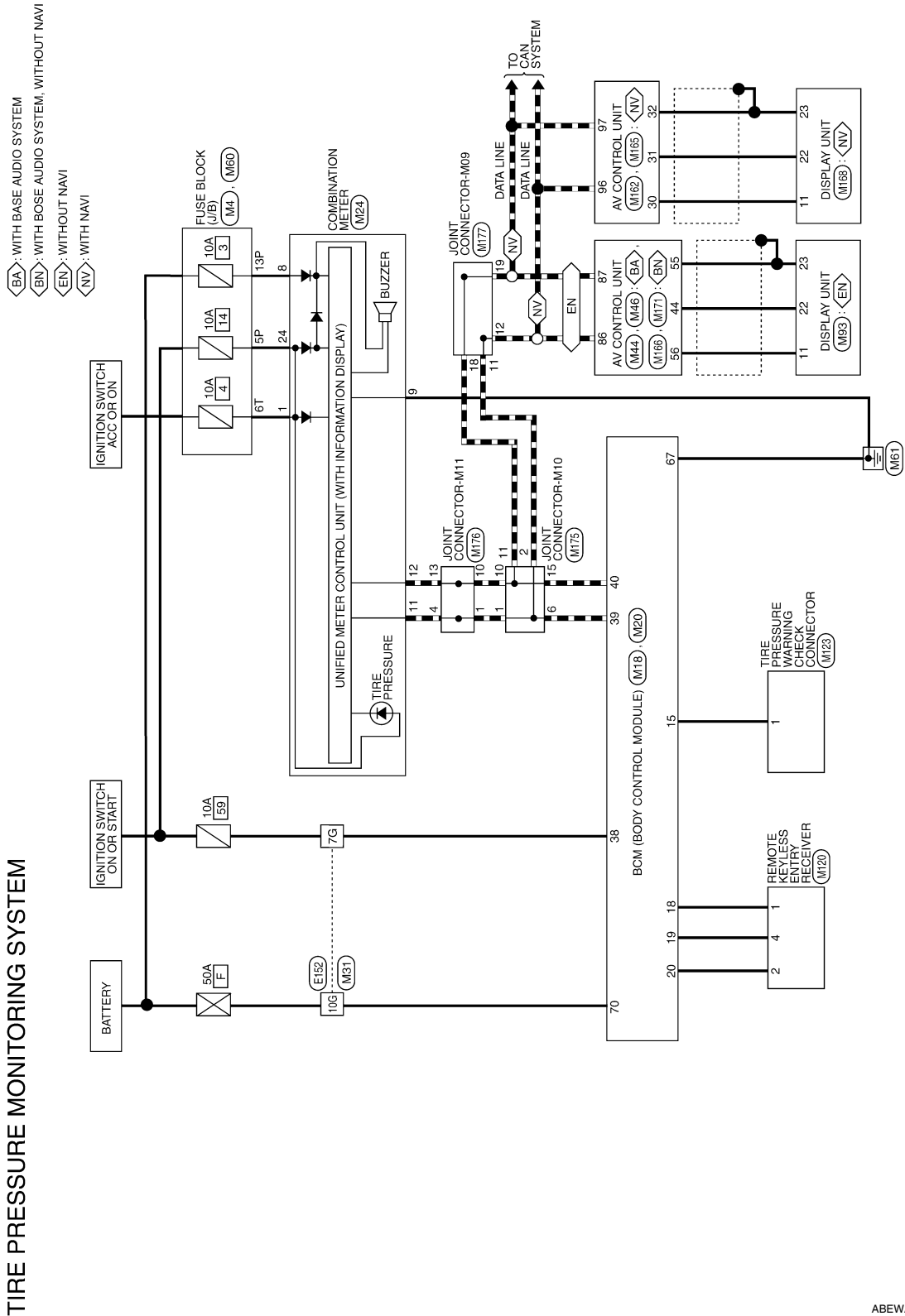

ABEWA0057GB



# TIRE PRESSURE MONITORING SYSTEM

< WIRING DIAGRAM >

## TIRE PRESSURE MONITORING SYSTEM CONNECTORS

Connector No.	M4
Connector Name	FUSE BLOCK (J/B)
Connector Color	WHITE



7P	6P	5P	4P	3P	2P	1P		
18P	15P	14P	13P	12P	11P	10P	9P	8P

Terminal No.	Color of Wire	Signal Name
5P	O/L	-
13P	P	-

Connector No.	M18
Connector Name	BCM (BODY CONTROL MODULE)
Connector Color	WHITE



1	2	3	4	5	6	7	8	9	10	11	12	13	14	15	16	17	18	19	20
21	22	23	24	25	26	27	28	29	30	31	32	33	34	35	36	37	38	39	40

Terminal No.	Color of Wire	Signal Name
15	L/W	TPMS MODE TRIGGER SW
18	P	KEYLESS AND AUTO LIGHT SENSOR GND
19	V/W	KEYLESS TUNER POWER SUPPLY OUTPUT
20	G/W	KEYLESS TUNER SIGNAL
38	W/L	IGN SW
39	L	CAN-H
40	P	CAN-L

Connector No.	M20
Connector Name	BCM (BODY CONTROL MODULE)
Connector Color	BLACK



56	57	58	59	60	61	62	63	64
65	66	67	68	69	70			

Terminal No.	Color of Wire	Signal Name
67	B	GND (POWER)
70	W/B	BAT (FL)

Connector No.	M24
Connector Name	COMBINATION METER
Connector Color	WHITE



20	19	18	17	16	15	14	13	12	11	10	9	8	7	6	5	4	3	2	1
40	39	38	37	36	35	34	33	32	31	30	29	28	27	26	25	24	23	22	21

Terminal No.	Color of Wire	Signal Name
1	O	ACCESSORY
8	P	BATTERY
9	B	GND (POWER)
11	L	CAN-H
12	P	CAN-L
24	O/L	RUN/START

A  
B  
C  
D  
WT  
F  
G  
H  
I  
J  
K  
L  
M  
N  
O  
P

# TIRE PRESSURE MONITORING SYSTEM

< WIRING DIAGRAM >

Connector No.	M46
Connector Name	AV CONTROL UNIT (WITH BASE AUDIO SYSTEM)
Connector Color	WHITE



91	90	89	88	87	86	85	84	83	82	81	80	79	78	77	76
107	106	105	104	103	102	101	100	99	98	97	96	95	94	93	92

Terminal No.	Color of Wire	Signal Name
86	L	CAN-H
87	P	CAN-L

Connector No.	M44
Connector Name	AV CONTROL UNIT (WITH BASE AUDIO SYSTEM)
Connector Color	WHITE



47	46	45	44	43	42	41	40	39	38	37	36
59	58	57	56	55	54	53	52	51	50	49	48

Terminal No.	Color of Wire	Signal Name
44	LG	DISP IT
55	SHIELD	SHIELD
56	V	IT DISP

Connector No.	M31
Connector Name	WIRE TO WIRE
Connector Color	WHITE

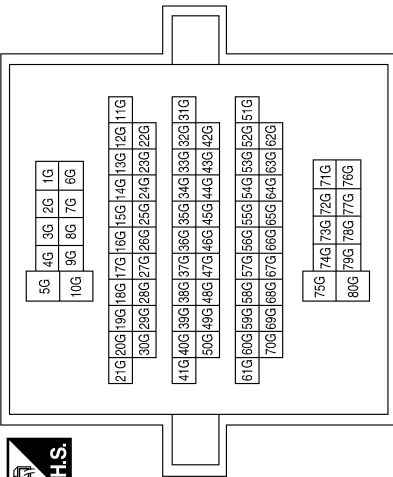

Terminal No.	Color of Wire	Signal Name
7G	W/L	-
10G	W/B	-

Connector No.	M60
Connector Name	FUSE BLOCK (J/B)
Connector Color	WHITE



2T	1T
6T	5T
4T	3T

Terminal No.	Color of Wire	Signal Name
6T	O	-

Connector No.	M120
Connector Name	REMOTE KEY LESS ENTRY RECEIVER
Connector Color	WHITE



1	2	3	4
---	---	---	---

Connector No.	M93
Connector Name	DISPLAY UNIT (WITHOUT NAVI)
Connector Color	WHITE



12	11	10	9	8	7	6	5	4	3	2	1
24	23	22	21	20	19	18	17	16	15	14	13

Terminal No.	Color of Wire	Signal Name
11	V	IT DISP
22	LG	DISP IT
23	SHIELD	SHIELD

Terminal No.	Color of Wire	Signal Name
1	P	GND
2	G/W	SIGNAL
4	V/W	POWER

# TIRE PRESSURE MONITORING SYSTEM

< WIRING DIAGRAM >

Connector No.	M123
Connector Name	TIRE PRESSURE WARNING CHECK CONNECTOR
Connector Color	WHITE



Terminal No.	Color of Wire	Signal Name
1	L/W	TPMS TRIGGER SW

Connector No.	M162
Connector Name	AV CONTROL UNIT (WITH BOSE AUDIO SYSTEM, WITH NAVI)
Connector Color	WHITE

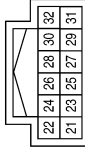

Terminal No.	Color of Wire	Signal Name
30	V	IT DISP
31	LG	DISP IT
32	SHIELD	SHIELD

Connector No.	M165
Connector Name	AV CONTROL UNIT (WITH BOSE AUDIO SYSTEM, WITH NAVI)
Connector Color	WHITE

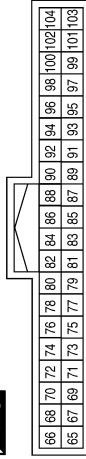

Terminal No.	Color of Wire	Signal Name
96	L	CAN-H
97	P	CAN-L

Connector No.	M166
Connector Name	AV CONTROL UNIT (WITH BOSE AUDIO SYSTEM, WITHOUT NAVI)
Connector Color	WHITE

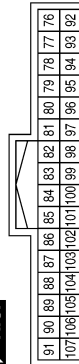

Terminal No.	Color of Wire	Signal Name
86	L	CAN-H
87	P	CAN-L

Connector No.	M168
Connector Name	DISPLAY UNIT (WITH NAVI)
Connector Color	WHITE

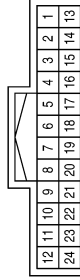

Terminal No.	Color of Wire	Signal Name
11	V	IT DISP
22	LG	DISP IT
23	SHIELD	SHIELD

Connector No.	M171
Connector Name	AV CONTROL UNIT (WITH BOSE AUDIO SYSTEM, WITHOUT NAVI)
Connector Color	WHITE



Terminal No.	Color of Wire	Signal Name
44	LG	DISP IT
55	SHIELD	SHIELD
56	V	IT DISP

ABEIA0103GB

A  
B  
C  
D  
E  
F  
G  
H  
I  
J  
K  
L  
M  
N  
O  
P

WT

# TIRE PRESSURE MONITORING SYSTEM

< WIRING DIAGRAM >

Connector No.	M177
Connector Name	JOINT CONNECTOR-M09
Connector Color	GREEN

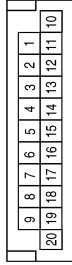

Terminal No.	Color of Wire	Signal Name
11	L	-
12	L	-
18	P	-
19	P	-

Connector No.	M176
Connector Name	JOINT CONNECTOR-M11
Connector Color	BLUE

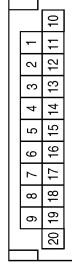

Terminal No.	Color of Wire	Signal Name
1	L	-
4	L	-
10	P	-
13	P	-

Connector No.	M175
Connector Name	JOINT CONNECTOR-M10
Connector Color	BLUE

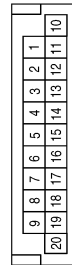

Terminal No.	Color of Wire	Signal Name
1	L	-
2	L	-
6	L	-
10	P	-
11	P	-
15	P	-

Terminal No.	Color of Wire	Signal Name
7G	L/W	-
10G	W/B	-

Connector No.	E152
Connector Name	WIRE TO WIRE
Connector Color	WHITE

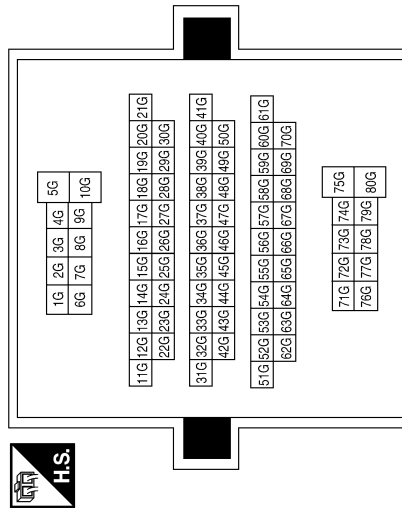

ABEIA0106GB

# TPMS

< SYMPTOM DIAGNOSIS >

## SYMPTOM DIAGNOSIS

### TPMS

#### Symptom Table

INFOID:000000006147239

Symptom	Reference
Low tire pressure warning lamp does not come on when ignition switch is turned ON.	<a href="#">WT-38</a>
Low tire pressure warning lamp stays on when ignition switch is turned ON.	<a href="#">WT-39</a>
Low tire pressure warning lamp flashes when ignition switch is turned ON.	<a href="#">WT-40</a>
Hazard warning lamps flash when ignition switch is turned ON.	<a href="#">WT-41</a>
Tire pressure information in display unit does not exist.	<a href="#">WT-43</a>
ID registration cannot be completed.	<a href="#">WT-43</a>

A

B

C

D

WT

F

G

H

I

J

K

L

M

N

O

P

# LOW TIRE PRESSURE WARNING LAMP DOES NOT TURN ON

< SYMPTOM DIAGNOSIS >

---

## LOW TIRE PRESSURE WARNING LAMP DOES NOT TURN ON

Low Tire Pressure Warning Lamp Does Not Come On When Ignition Switch Is Turned On

INFOID:000000006147240

### DIAGNOSTIC PROCEDURE

#### 1.SELF-DIAGNOSTIC RESULT CHECK

---

Using CONSULT-III, check display contents of BCM in SELF-DIAGNOSIS.

Is "CAN COMM CIRCUIT" displayed in the self-diagnosis display items?

- YES >> Malfunction in CAN communication system.
- NO >> GO TO 2

#### 2.CHECK COMBINATION METER

---

Check combination meter operation. Refer to [MWI-27, "CONSULT-III Function \(METER/M&A\)"](#).

Is the inspection result normal?

- YES >> GO TO 3
- NO >> Replace combination meter. Refer to [MWI-97, "Removal and Installation"](#).

#### 3.CHECK LOW TIRE PRESSURE WARNING LAMP

---

Disconnect BCM harness connector.

Does the low tire pressure warning lamp activate?

- YES >> Replace BCM. Refer to [BCS-56, "Removal and Installation"](#).
- NO >> Check combination meter operation.

# LOW TIRE PRESSURE WARNING LAMP STAYS ON

< SYMPTOM DIAGNOSIS >

## LOW TIRE PRESSURE WARNING LAMP STAYS ON

Low Tire Pressure Warning Lamp Stays On When Ignition Switch Is Turned On

INFOID:000000006147241

### DIAGNOSTIC PROCEDURE

#### 1. BCM CONNECTORS

1. Turn ignition switch OFF.
2. Disconnect BCM harness connectors.
3. Check terminals for damage or loose connections.

Is the inspection result normal?

YES >> GO TO 2

NO >> Repair or replace damaged parts.

#### 2. BCM POWER SUPPLY AND GROUND CIRCUITS

Check BCM power supply and ground circuits. Refer to [BCS-30. "Diagnosis Procedure"](#).

Is the inspection result normal?

YES >> Replace BCM. Refer to [BCS-56. "Removal and Installation"](#).

NO >> Repair BCM circuits.

A  
B  
C  
D  
WT  
F  
G  
H  
I  
J  
K  
L  
M  
N  
O  
P

# LOW TIRE PRESSURE WARNING LAMP BLINKS

< SYMPTOM DIAGNOSIS >

## LOW TIRE PRESSURE WARNING LAMP BLINKS

Low Tire Pressure Warning Lamp Flashes When Ignition Switch Is Turned On

INFOID:000000006147242

### NOTE:

If low tire pressure warning lamp flashes as shown, the system is normal.

Flash Mode A

- This mode shows transmitter status is OFF-mode.  
Carry out transmitter wake up operation. Refer to [WT-5. "Transmitter Wake Up Operation"](#).

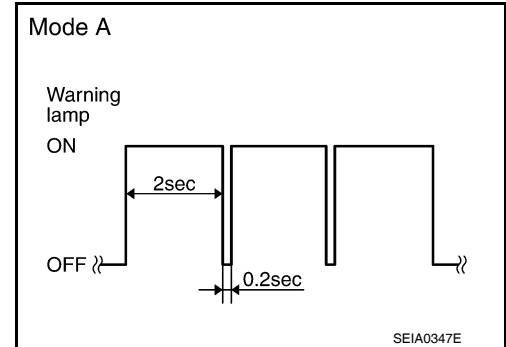

### DIAGNOSTIC PROCEDURE

#### 1. CHECK BCM CONNECTORS

1. Turn ignition switch OFF.
2. Disconnect BCM harness connectors.
3. Check terminals for damage or loose connections.

Is the inspection result normal?

YES >> GO TO 2

NO >> Repair or replace damaged parts.

#### 2. CHECK TIRE PRESSURE WARNING CHECK CONNECTOR CIRCUIT

Check continuity between BCM harness connector M18 terminal 15 and ground.

**Continuity should not exist.**

Is the inspection result normal?

YES >> Replace BCM. Refer to [BCS-56. "Removal and Installation"](#).

NO >> Repair circuit for short to ground.

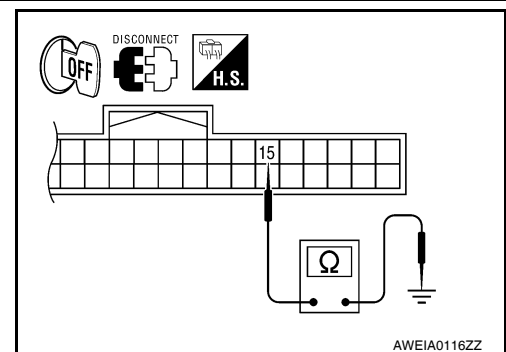



# HAZARD WARNING LAMPS FLASH

< SYMPTOM DIAGNOSIS >

## HAZARD WARNING LAMPS FLASH

Hazard Warning Lamps Flash When Ignition Switch Is Turned On

INFOID:000000006147243

### DIAGNOSTIC PROCEDURE

#### 1. CHECK BCM GROUND CIRCUIT

Check BCM ground circuit. Refer to [BCS-30, "Diagnosis Procedure"](#).

Is the inspection result normal?

YES >> Replace BCM. Refer to [BCS-56, "Removal and Installation"](#).

NO >> Repair BCM ground circuit.

A  
B  
C  
D  
E  
F  
G  
H  
I  
J  
K  
L  
M  
N  
O  
P

WT

# "TIRE PRESSURE" INFORMATION IN DISPLAY UNIT DOES NOT EXIST

< SYMPTOM DIAGNOSIS >

---

## "TIRE PRESSURE" INFORMATION IN DISPLAY UNIT DOES NOT EXIST

"TIRE PRESSURE" Information in Display Unit Does Not Exist

INFOID:000000006147244

### DIAGNOSTIC PROCEDURE

#### 1. SELF-DIAGNOSTIC RESULT CHECK

---

Using CONSULT-III, check display contents in self-diagnostic results.

Is "CAN COMM CIRCUIT" displayed in the self-diagnosis display items?

YES >> Malfunction in CAN communication system.

NO >> GO TO 2.

#### 2. CHECK DISPLAY UNIT

---

Perform display unit self-diagnosis. Refer to [AV-295. "AV CONTROL UNIT : CONSULT-III Function"](#).

Is the inspection result normal?

YES >> Replace BCM. Refer to [BCS-56. "Removal and Installation"](#) .

NO >> Repair or replace malfunctioning parts.

# ID REGISTRATION CANNOT BE COMPLETED

< SYMPTOM DIAGNOSIS >

---

## ID REGISTRATION CANNOT BE COMPLETED

ID Registration Cannot Be Completed

INFOID:000000006147245

DIAGNOSTIC PROCEDURE

### 1. PERFORM ID REGISTRATION OF ALL TRANSMITTERS

---

Carry out ID registration of all transmitters. Refer to [WT-6. "ID Registration Procedure"](#).

Can ID registration of all transmitters be completed?

YES >> Inspection End.

NO >> Refer to [WT-14. "Diagnosis Procedure"](#).

A  
B  
C  
D  
E  
F  
G  
H  
I  
J  
K  
L  
M  
N  
O  
P

WT

# NOISE, VIBRATION, AND HARSHNESS (NVH) TROUBLESHOOTING

< SYMPTOM DIAGNOSIS >

## NOISE, VIBRATION, AND HARSHNESS (NVH) TROUBLESHOOTING

### NVH Troubleshooting Chart

INFOID:000000006147246

Use chart below to help you find the cause of the symptom. If necessary, repair or replace these parts.

Symptom		Possible cause and SUSPECTED PARTS													Reference page		
		Out-of-round	Imbalance	Incorrect tire pressure	Uneven tire wear	Deformation or damage	Non-uniformity	Incorrect tire size	FRONT AND REAR FINAL DRIVE	FRONT AXLE AND FRONT SUSPENSION	REAR AXLE AND REAR SUSPENSION	TIRES	ROAD WHEEL	BRAKE	STEERING		
TIRES	Noise	x	x	x	x	x	x	x	x	x	x	x	x	x	x	x	WT-48
	Shake	x	x	x	x	x		x		x	x	x		x	x		WT-49
	Vibration			x				x		x	x	x					WT-54
	Shimmy	x	x	x	x	x	x	x		x	x	x		x	x		WT-50
	Shudder	x	x	x	x	x		x		x	x	x		x	x		—
	Poor quality ride or handling	x	x	x	x	x		x		x	x	x					—
																	WT-54
ROAD WHEEL	Noise	x	x			x			x	x	x		x	x	x	DLN-208, "NVH Troubleshooting Chart" (FFD) DLN-242, "NVH Troubleshooting Chart" (RFD)	
	Shake	x	x			x				x	x		x	x	x	FAX-5, "NVH Troubleshooting Chart" (FAX) FSU-6, "NVH Troubleshooting Chart" (FSU)	
	Shimmy, shudder	x	x			x				x	x		x	x	x	RAX-5, "NVH Troubleshooting Chart" (RAX) RSU-5, "NVH Troubleshooting Chart" (RSU)	
	Poor quality ride or handling	x	x			x					x	x		x		Refer to TIRES in this chart. Refer to ROAD WHEEL in this chart. BR-6, "NVH Troubleshooting Chart" ST-9, "NVH Troubleshooting Chart"	

x: Applicable

# PRECAUTIONS

< PRECAUTION >

## PRECAUTION

### PRECAUTIONS

#### Precaution for Supplemental Restraint System (SRS) "AIR BAG" and "SEAT BELT PRE-TENSIONER"

INFOID:000000006147247

The Supplemental Restraint System such as "AIR BAG" and "SEAT BELT PRE-TENSIONER", used along with a front seat belt, helps to reduce the risk or severity of injury to the driver and front passenger for certain types of collision. This system includes seat belt switch inputs and dual stage front air bag modules. The SRS system uses the seat belt switches to determine the front air bag deployment, and may only deploy one front air bag, depending on the severity of a collision and whether the front occupants are belted or unbelted. Information necessary to service the system safely is included in the SR and SB section of this Service Manual.

#### **WARNING:**

- To avoid rendering the SRS inoperative, which could increase the risk of personal injury or death in the event of a collision which would result in air bag inflation, all maintenance must be performed by an authorized NISSAN/INFINITI dealer.
- Improper maintenance, including incorrect removal and installation of the SRS, can lead to personal injury caused by unintentional activation of the system. For removal of Spiral Cable and Air Bag Module, see the SR section.
- Do not use electrical test equipment on any circuit related to the SRS unless instructed to in this Service Manual. SRS wiring harnesses can be identified by yellow and/or orange harnesses or harness connectors.

#### PRECAUTIONS WHEN USING POWER TOOLS (AIR OR ELECTRIC) AND HAMMERS

#### **WARNING:**

- When working near the Airbag Diagnosis Sensor Unit or other Airbag System sensors with the Ignition ON or engine running, DO NOT use air or electric power tools or strike near the sensor(s) with a hammer. Heavy vibration could activate the sensor(s) and deploy the air bag(s), possibly causing serious injury.
- When using air or electric power tools or hammers, always switch the Ignition OFF, disconnect the battery, and wait at least 3 minutes before performing any service.

#### Precaution Necessary for Steering Wheel Rotation After Battery Disconnect

INFOID:000000006147248

#### **NOTE:**

- This Procedure is applied only to models with Intelligent Key system and NATS (NISSAN ANTI-THEFT SYSTEM).
- Remove and install all control units after disconnecting both battery cables with the ignition knob in the "LOCK" position.
- Always use CONSULT-III to perform self-diagnosis as a part of each function inspection after finishing work. If DTC is detected, perform trouble diagnosis according to self-diagnostic results.

For models equipped with the Intelligent Key system and NATS, an electrically controlled steering lock mechanism is adopted on the key cylinder.

For this reason, if the battery is disconnected or if the battery is discharged, the steering wheel will lock and steering wheel rotation will become impossible.

If steering wheel rotation is required when battery power is interrupted, follow the procedure below before starting the repair operation.

#### OPERATION PROCEDURE

1. Connect both battery cables.

#### **NOTE:**

Supply power using jumper cables if battery is discharged.

2. Use the Intelligent Key or mechanical key to turn the ignition switch to the "ACC" position. At this time, the steering lock will be released.
3. Disconnect both battery cables. The steering lock will remain released and the steering wheel can be rotated.
4. Perform the necessary repair operation.

## PRECAUTIONS

### < PRECAUTION >

---

5. When the repair work is completed, return the ignition switch to the "LOCK" position before connecting the battery cables. (At this time, the steering lock mechanism will engage.)
6. Perform a self-diagnosis check of all control units using CONSULT-III.

### Precaution for Work

INFOID:000000006627316

- When removing or disassembling each component, be careful not to damage or deform it. If a component may be subject to interference, be sure to protect it with a shop cloth.
- When removing (disengaging) components with a screwdriver or similar tool, be sure to wrap the component with a shop cloth or vinyl tape to protect it.
- Protect the removed parts with a shop cloth and prevent them from being dropped.
- Replace a deformed or damaged clip.
- If a part is specified as a non-reusable part, always replace it with new one.
- Be sure to tighten bolts and nuts securely to the specified torque.
- After installation is complete, be sure to check that each part works properly.
- Follow the steps below to clean components.
  - Water soluble dirt: Dip a soft cloth into lukewarm water, and wring the water out of the cloth to wipe the dirty area.  
Then rub with a soft and dry cloth.
  - Oily dirt: Dip a soft cloth into lukewarm water with mild detergent (concentration: within 2 to 3%), and wipe the dirty area.  
Then dip a cloth into fresh water, and wring the water out of the cloth to wipe the detergent off. Then rub with a soft and dry cloth.
- Do not use organic solvent such as thinner, benzene, alcohol, or gasoline.
- For genuine leather seats, use a genuine leather seat cleaner.

# PREPARATION

< PREPARATION >

## PREPARATION

### PREPARATION

#### Special Service Tool

INFOID:000000006147250

The actual shapes of Kent-Moore tools may differ from those of special service tools illustrated here.

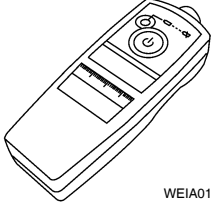
Tool number (Kent-Moore No.) Tool name	Description
KV991B1000 (J-45295) Transmitter activation tool   WEIA0144E	<ul style="list-style-type: none"> <li>• Transmitter wake up operation</li> <li>• ID registration procedure</li> </ul>

#### Commercial Service Tool

INFOID:000000006147251

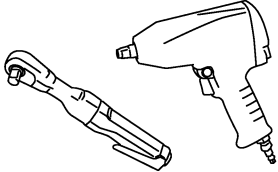
Tool name	Description
Power tool   PBIC0190E	Removing wheel nuts

# WHEEL

< PERIODIC MAINTENANCE >

## PERIODIC MAINTENANCE

### WHEEL

#### Inspection

INFOID:000000006147252

#### ALUMINUM WHEEL

1. Check tires for wear and improper inflation.
2. Check wheels for deformation, cracks and other damage. If deformed, remove wheel and check wheel runout.
  - a. Remove tire from aluminum wheel and mount on a tire balance machine.
  - b. Set dial indicator as shown in the figure.

**Wheel runout (Dial indicator value):**  
Refer to [WT-54, "Road Wheel"](#).

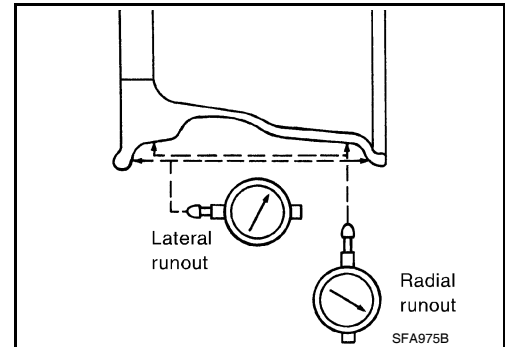

#### STEEL WHEEL

1. Check tires for wear and improper inflation.
2. Check wheels for deformation, cracks and other damage. If deformed, remove wheel and check wheel runout.
  - a. Remove tire from steel wheel and mount on a tire balance machine.
  - b. Set two dial indicators as shown in the figure.
  - c. Set each dial indicator to 0.
  - d. Rotate wheel and check dial indicators at several points around the circumference of the wheel.
  - e. Calculate runout at each point as shown below.

**Radial runout = (A+B)/2**  
**Lateral runout = (C+D)/2**

- f. Select maximum positive runout value and the maximum negative value. Add the two values to determine total runout. In case a positive or negative value is not available, use the maximum value (negative or positive) for total runout. If the total runout value exceeds the limit, replace steel wheel.

**Wheel runout** : Refer to [WT-54, "Road Wheel"](#).

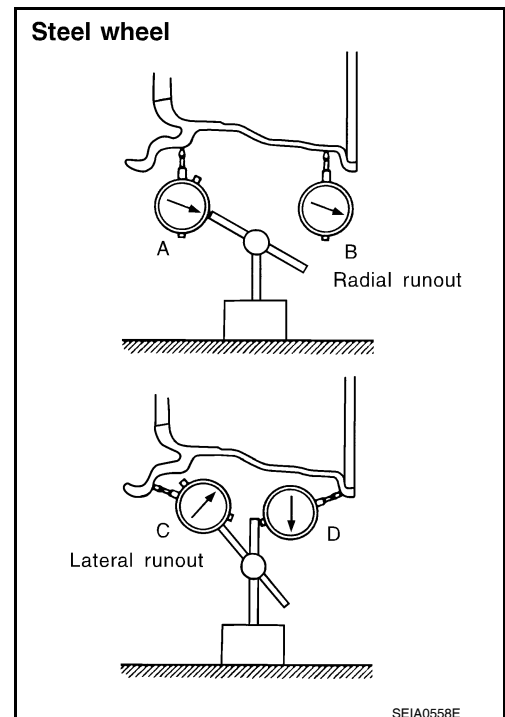



# WHEEL AND TIRE ASSEMBLY

< REMOVAL AND INSTALLATION >

## REMOVAL AND INSTALLATION

### WHEEL AND TIRE ASSEMBLY

#### Balancing Wheels

INFOID:000000006147253

#### BALANCING WHEELS (ADHESIVE WEIGHT TYPE)

##### Preparation Before Adjustment

Remove inner and outer balance weights from the road wheel using releasing agent, remove double-faced adhesive tape from the road wheel.

##### **CAUTION:**

- **Be careful not scratch the road wheel during removal.**
- **After removing double-faced adhesive tape, wipe clean traces of releasing agent from the road wheel.**

##### Wheel Balance Adjustment

• If a balancer machine has an adhesive weight mode setting, select the adhesive weight mode setting and skip Step 2. below. If a balancer machine only has the clip-on (rim flange) weight mode setting, follow Step 2. to calculate the correct size adhesive weight.

1. Set road wheel on balancer machine using the center hole as a guide. Start the balancer machine.
  2. For tire balance machines that only have a clip-on (rim flange) weight mode setting, follow this step to calculate the correct size adhesive weight to use. When inner and outer imbalance values are shown on the balancer machine indicator, multiply outer imbalance value by 5/3 (1.67) to determine balance weight that should be used. Select the outer balance weight with a value closest to the calculated value above and install in to the designated outer position of, or at the designated angle in relation to the road wheel.
- a. Indicated imbalance value  $\times 5/3$  (1.67) = balance weight to be installed

##### **Calculation example:**

23 g (0.81 oz)  $\times 5/3$  (1.67) = 38.33 g (1.35 oz)  $\Rightarrow$  40 g (1.41 oz)  
balance weight (closer to calculated balance weight value)

##### **NOTE:**

Note that balance weight value must be closer to the calculated balance weight value.

##### **Example:**

37.4  $\Rightarrow$  35 g (1.23 oz)

37.5  $\Rightarrow$  40 g (1.41 oz)

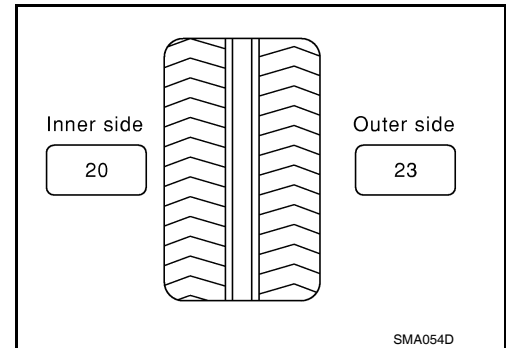

# WHEEL AND TIRE ASSEMBLY

## < REMOVAL AND INSTALLATION >

3. Install balance weight in the position shown.

**CAUTION:**

- Do not install the inner balance weight before installing the outer balance weight.
- Before installing the balance weight, be sure to clean the mating surface of the road wheel.
- When installing balance weight (1) to road wheel, set it into the grooved area (A) on the inner wall of the road wheel as shown so that the balance weight center (B) is aligned with the balancer machine indication position (angle) (C).

**CAUTION:**

- Always use genuine NISSAN adhesive balance weights.
- Balance weights are non-reusable; always replace with new ones.
- Do not install more than three sheets of balance weight.

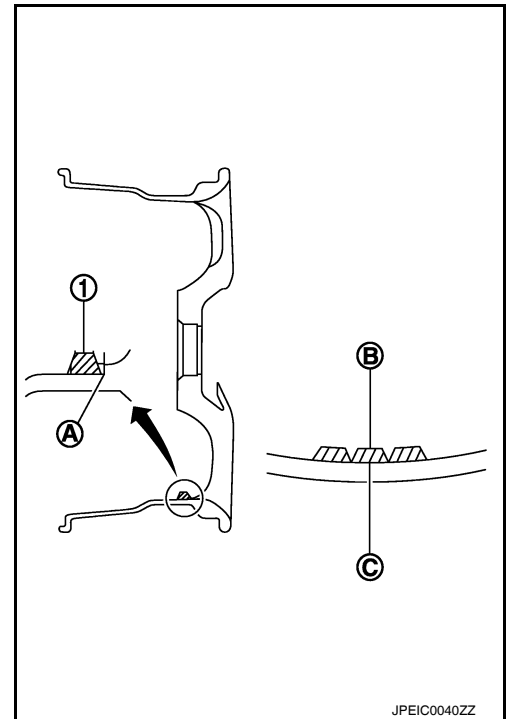

4. If calculated balance weight value exceeds 50 g (1.76 oz), install two balance weight sheets in line with each other as shown.

**CAUTION:**

**Do not install one balance weight sheet on top another.**

5. Start balancer machine again.

6. Install balance weight on inner side of road wheel in the balancer machine indication position (angle).

**CAUTION:**

**Do not install more than two balance weights.**

7. Start balancer machine. Make sure that inner and outer residual imbalance values are 5 g (0.17 oz) each or below.

8. If either residual imbalance value exceeds 5 g (0.17 oz), repeat installation procedures.

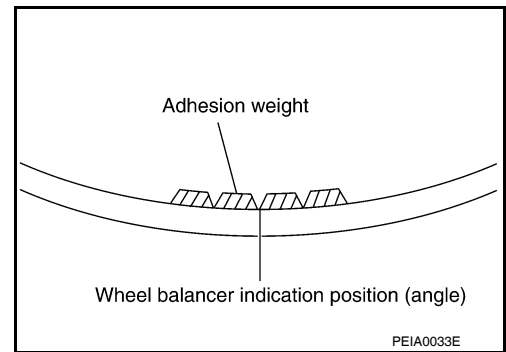

Wheel balance	Dynamic (At flange)	Static (At flange)
Maximum allowable imbalance	Refer to <a href="#">WT-54, "Road Wheel"</a> .	

## Rotation

INFOID:000000006147254

### TIRE ROTATION

- Follow the maintenance schedule for tire rotation service intervals. Refer to [MA-10, "FOR USA AND CANADA : Introduction of Periodic Maintenance"](#) (United States and Canada), [MA-17, "FOR MEXICO : Introduction of Periodic Maintenance"](#) (Mexico).
- Rotate the wheel and tires front to back in the pattern as shown. When installing the wheel and tires, tighten the wheel nuts diagonally to the specified torque.

**Wheel nut tightening torque : 133 N·m (14 kg-m, 98 ft-lb)**

**CAUTION:**

- Do not include the spare wheel and tire when rotating the wheel and tires.

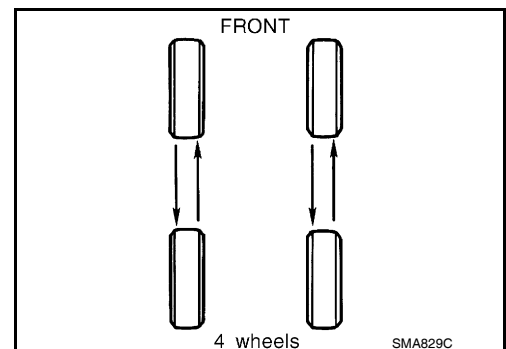

## WHEEL AND TIRE ASSEMBLY

### < REMOVAL AND INSTALLATION >

---

- **When installing the wheel nuts, tighten them diagonally by dividing the work two to three times in order to prevent the wheels from developing any distortion.**
- **Be careful not to tighten the wheel nuts to a torque exceeding specification to prevent strain on the disc rotor.**
- **Use genuine NISSAN wheel nuts for aluminum wheels.**

A

B

C

D

WT

F

G

H

I

J

K

L

M

N

O

P

# TRANSMITTER

< UNIT REMOVAL AND INSTALLATION >

## UNIT REMOVAL AND INSTALLATION

### TRANSMITTER

#### Transmitter (Pressure Sensor)

INFOID:000000006147255

#### REMOVAL

1. Deflate tire. Unscrew transmitter retaining nut and allow transmitter to fall into tire.
2. Gently bounce tire so that transmitter falls to bottom of tire. Place wheel and tire assembly on tire changing machine and break both tire beads. Ensure that the transmitter remains at the bottom of the tire while breaking the bead.

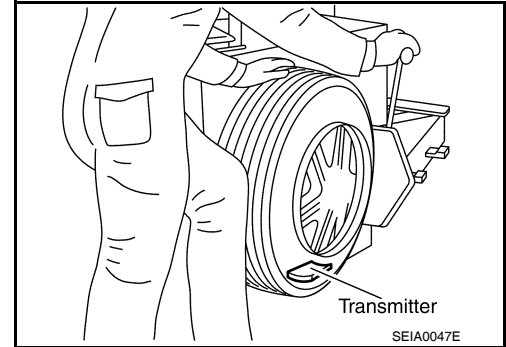

3. Turn tire so that valve hole is at bottom, and gently bounce the tire to ensure transmitter is near valve hole. Carefully lift tire onto turntable and position valve hole (and transmitter) 270 degrees from mounting/dismounting head.
4. Lubricate tire well, and remove top side of tire. Reach inside the tire and remove the transmitter.
5. Remove the second side of the tire as normal.

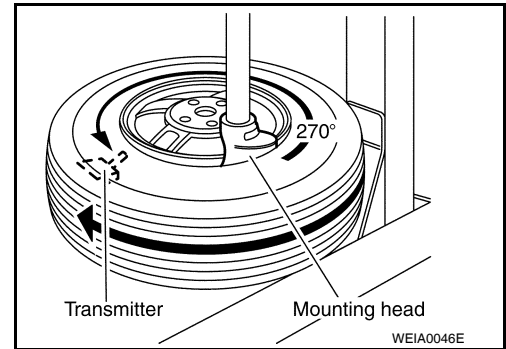

#### INSTALLATION

1. Place first side of tire onto rim.

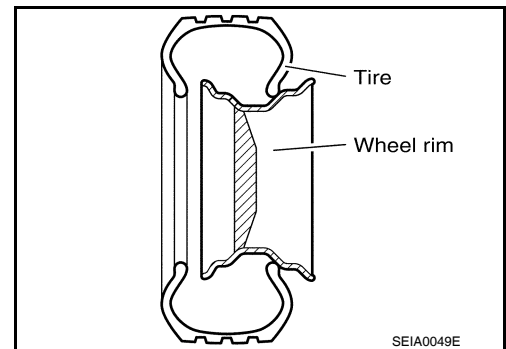

2. Mount transmitter on rim and tighten nut to specification.

**Transmitter nut : 7.7 N-m (0.79 kg-m, 68 in-lb)**

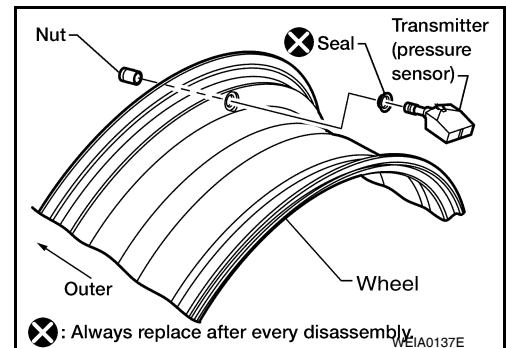

⊗: Always replace after every disassembly

# TRANSMITTER

## < UNIT REMOVAL AND INSTALLATION >

3. Place wheel on turntable of tire machine. Ensure that transmitter is 270 degrees from mounting/dismounting head.

**NOTE:**

Do not touch transmitter with mounting head.

4. Lubricate tire well, and install second side of tire as normal. Ensure that tire does not rotate relative to rim.
5. Inflate tire and balance the wheel and tire assembly. Refer to [WT-49, "Balancing Wheels"](#).
6. Install wheel and tire assembly in appropriate wheel position on vehicle.

**NOTE:**

If replacing transmitter, transmitter wake up operation must be performed. Refer to [WT-5, "Transmitter Wake Up Operation"](#).

7. Adjust neutral position of steering angle sensor. Refer to [BRC-8, "ADJUSTMENT OF STEERING ANGLE SENSOR NEUTRAL POSITION : Special Repair Requirement"](#).

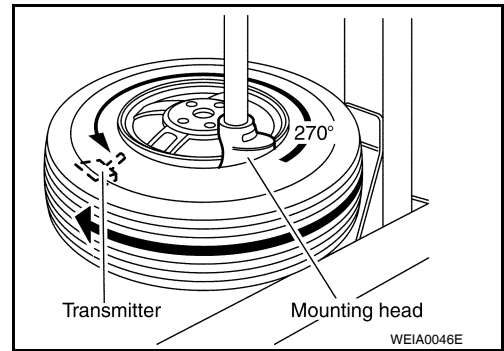

A  
B  
C  
D  
WT  
F  
G  
H  
I  
J  
K  
L  
M  
N  
O  
P

## SERVICE DATA AND SPECIFICATIONS (SDS)

< SERVICE DATA AND SPECIFICATIONS (SDS)

# SERVICE DATA AND SPECIFICATIONS (SDS)

## SERVICE DATA AND SPECIFICATIONS (SDS)

### Road Wheel

INFOID:000000006147256

Wheel type		Aluminum	Steel	
			Inside	Outside
Maximum radial runout limit	Lateral mm (in)	0.3 (0.012) or less	1.0 (0.039) or less	0.9 (0.035) or less
	Radial mm (in)	0.3 (0.012) or less	0.8 (0.031) or less	0.4 (0.016) or less
Maximum residual imbalance	Dynamic (at rim flange)	Less than 5 g (0.18 oz) (per side)		
	Static (at rim flange)	Less than 10 g (0.35 oz)		

### Tire

INFOID:000000006147257

Unit: kPa (kg/cm<sup>2</sup> , psi)

Tire size	Air pressure	
	Conventional tire	Spare tire
P265/70R18	240 (2.4, 35)	240 (2.4, 35)
P275/60R20	240 (2.4, 35)	240 (2.4, 35)