

SECTION **MA**  
 MAINTENANCE

A  
B  
C  
D  
E  
F  
G  
H  
I  
J  
K  
L  
M  
N  
O  
MA

CONTENTS

<b>PRECAUTION</b> .....	3	FOR USA AND CANADA : Engine Oil Recommendation .....	17
<b>PRECAUTIONS</b> .....	3	FOR USA AND CANADA : Engine Coolant Mixture Ratio .....	18
Precaution for Supplemental Restraint System (SRS) "AIR BAG" and "SEAT BELT PRE-TENSIONER" .....	3	<b>FOR MEXICO</b> .....	18
Precaution Necessary for Steering Wheel Rotation After Battery Disconnect .....	3	FOR MEXICO : Fluids and Lubricants .....	18
<b>PREPARATION</b> .....	5	FOR MEXICO : SAE Viscosity Number .....	19
<b>PREPARATION</b> .....	5	<b>ENGINE MAINTENANCE</b> .....	21
Special Service Tool .....	5	<b>DRIVE BELTS</b> .....	21
Commercial Service Tool .....	5	DRIVE BELTS : Checking Drive Belts .....	21
<b>PERIODIC MAINTENANCE</b> .....	6	<b>ENGINE COOLANT</b> .....	21
<b>GENERAL MAINTENANCE</b> .....	6	ENGINE COOLANT : Inspection .....	21
<b>FOR USA AND CANADA</b> .....	6	ENGINE COOLANT : Changing Engine Coolant .....	22
FOR USA AND CANADA : General Maintenance.....	6	<b>FUEL LINES</b> .....	24
<b>FOR MEXICO</b> .....	8	FUEL LINES : Checking Fuel Line .....	24
FOR MEXICO : General Maintenance .....	8	<b>FUEL FILTER</b> .....	24
<b>PERIODIC MAINTENANCE</b> .....	10	FUEL FILTER : Removal and Installation .....	24
<b>FOR USA AND CANADA</b> .....	10	<b>AIR CLEANER FILTER</b> .....	24
FOR USA AND CANADA : Introduction of Periodic Maintenance .....	10	AIR CLEANER FILTER : Removal and Installation (Viscous paper type) .....	24
FOR USA AND CANADA : Schedule 1 .....	10	<b>ENGINE OIL</b> .....	25
FOR USA AND CANADA : Schedule 2 .....	12	ENGINE OIL : Inspection .....	25
<b>FOR MEXICO</b> .....	13	ENGINE OIL : Changing Engine Oil .....	25
FOR MEXICO : Introduction of Periodic Maintenance .....	14	<b>OIL FILTER</b> .....	26
<b>RECOMMENDED FLUIDS AND LUBRICANTS</b> .....	17	OIL FILTER : Removal and Installation .....	26
<b>FOR USA AND CANADA</b> .....	17	<b>SPARK PLUG</b> .....	27
FOR USA AND CANADA : Fluids and Lubricants... 17	17	SPARK PLUG : Removal and Installation .....	27
		<b>EVAP VAPOR LINES</b> .....	28
		EVAP VAPOR LINES : Checking EVAP Vapor Line .....	28
		<b>CHASSIS AND BODY MAINTENANCE</b> .....	29
		<b>IN-CABIN MICROFILTER</b> .....	29

IN-CABIN MICROFILTER : Removal and Installation .....	29	<b>BRAKE LINES AND CABLES .....</b>	<b>38</b>
<b>EXHAUST SYSTEM .....</b>	<b>29</b>	BRAKE LINES AND CABLES : Checking Brake Line and Cables .....	38
EXHAUST SYSTEM : Checking Exhaust System...	29	<b>DISC BRAKE .....</b>	<b>38</b>
<b>A/T FLUID .....</b>	<b>30</b>	DISC BRAKE : Front Brake Pad Inspection .....	38
A/T FLUID : Checking the A/T Fluid (ATF) .....	30	DISC BRAKE : Front Brake Rotor Inspection .....	38
A/T FLUID : Changing the A/T Fluid (ATF) .....	32	DISC BRAKE : Rear Brake Pad Inspection .....	39
<b>TRANSFER FLUID .....</b>	<b>33</b>	DISC BRAKE : Rear Brake Rotor Inspection .....	39
TRANSFER FLUID : Replacement .....	33	<b>STEERING GEAR AND LINKAGE .....</b>	<b>39</b>
TRANSFER FLUID : Inspection .....	34	STEERING GEAR AND LINKAGE : Checking Steering Gear and Linkage .....	39
<b>PROPELLER SHAFT .....</b>	<b>34</b>	<b>POWER STEERING FLUID AND LINES .....</b>	<b>40</b>
PROPELLER SHAFT : Checking Propeller Shaft...	34	POWER STEERING FLUID AND LINES : Checking Fluid Level .....	40
<b>FRONT DIFFERENTIAL GEAR OIL .....</b>	<b>34</b>	POWER STEERING FLUID AND LINES : Checking Fluid Leakage .....	40
FRONT DIFFERENTIAL GEAR OIL : Changing Differential Gear Oil .....	34	<b>AXLE AND SUSPENSION PARTS .....</b>	<b>40</b>
FRONT DIFFERENTIAL GEAR OIL : Checking Differential Gear Oil .....	35	AXLE AND SUSPENSION PARTS : Checking Axle and Suspension Parts .....	40
<b>REAR DIFFERENTIAL GEAR OIL .....</b>	<b>35</b>	<b>LOCKS AND HINGES .....</b>	<b>41</b>
REAR DIFFERENTIAL GEAR OIL : Changing Differential Gear Oil .....	35	LOCKS AND HINGES : Lubricating Locks, Hinges and Hood Latches .....	42
REAR DIFFERENTIAL GEAR OIL : Checking Differential Gear Oil .....	35	<b>SEAT BELT, BUCKLES, RETRACTORS, ANCHORS AND ADJUSTERS .....</b>	<b>42</b>
<b>WHEELS .....</b>	<b>36</b>	SEAT BELT, BUCKLES, RETRACTORS, ANCHORS AND ADJUSTERS : Checking Seat Belts, Buckles, Retractors, Anchors and Adjusters ...	42
WHEELS : Balancing Wheels .....	36		
WHEELS : Rotation .....	37		
<b>BRAKE FLUID LEVEL AND LEAKS .....</b>	<b>38</b>		
BRAKE FLUID LEVEL AND LEAKS : On Board Inspection .....	38		

# PRECAUTIONS

< PRECAUTION >

## PRECAUTION

### PRECAUTIONS

#### Precaution for Supplemental Restraint System (SRS) "AIR BAG" and "SEAT BELT PRE-TENSIONER"

INFOID:000000008633137

The Supplemental Restraint System such as "AIR BAG" and "SEAT BELT PRE-TENSIONER", used along with a front seat belt, helps to reduce the risk or severity of injury to the driver and front passenger for certain types of collision. This system includes seat belt switch inputs and dual stage front air bag modules. The SRS system uses the seat belt switches to determine the front air bag deployment, and may only deploy one front air bag, depending on the severity of a collision and whether the front occupants are belted or unbelted. Information necessary to service the system safely is included in the SR and SB section of this Service Manual.

#### **WARNING:**

- To avoid rendering the SRS inoperative, which could increase the risk of personal injury or death in the event of a collision which would result in air bag inflation, all maintenance must be performed by an authorized NISSAN/INFINITI dealer.
- Improper maintenance, including incorrect removal and installation of the SRS, can lead to personal injury caused by unintentional activation of the system. For removal of Spiral Cable and Air Bag Module, see the SR section.
- Do not use electrical test equipment on any circuit related to the SRS unless instructed to in this Service Manual. SRS wiring harnesses can be identified by yellow and/or orange harnesses or harness connectors.

#### PRECAUTIONS WHEN USING POWER TOOLS (AIR OR ELECTRIC) AND HAMMERS

#### **WARNING:**

- When working near the Airbag Diagnosis Sensor Unit or other Airbag System sensors with the Ignition ON or engine running, DO NOT use air or electric power tools or strike near the sensor(s) with a hammer. Heavy vibration could activate the sensor(s) and deploy the air bag(s), possibly causing serious injury.
- When using air or electric power tools or hammers, always switch the Ignition OFF, disconnect the battery, and wait at least 3 minutes before performing any service.

#### Precaution Necessary for Steering Wheel Rotation After Battery Disconnect

INFOID:000000008633138

#### **NOTE:**

- This Procedure is applied only to models with Intelligent Key system and NATS (NISSAN ANTI-THEFT SYSTEM).
- Remove and install all control units after disconnecting both battery cables with the ignition knob in the "LOCK" position.
- Always use CONSULT to perform self-diagnosis as a part of each function inspection after finishing work. If DTC is detected, perform trouble diagnosis according to self-diagnostic results.

For models equipped with the Intelligent Key system and NATS, an electrically controlled steering lock mechanism is adopted on the key cylinder.

For this reason, if the battery is disconnected or if the battery is discharged, the steering wheel will lock and steering wheel rotation will become impossible.

If steering wheel rotation is required when battery power is interrupted, follow the procedure below before starting the repair operation.

#### OPERATION PROCEDURE

1. Connect both battery cables.

#### **NOTE:**

Supply power using jumper cables if battery is discharged.

2. Use the Intelligent Key or mechanical key to turn the ignition switch to the "ACC" position. At this time, the steering lock will be released.
3. Disconnect both battery cables. The steering lock will remain released and the steering wheel can be rotated.
4. Perform the necessary repair operation.

## PRECAUTIONS

### < PRECAUTION >

---

5. When the repair work is completed, return the ignition switch to the "LOCK" position before connecting the battery cables. (At this time, the steering lock mechanism will engage.)
6. Perform a self-diagnosis check of all control units using CONSULT.

# PREPARATION

< PREPARATION >

## PREPARATION

### PREPARATION

#### Special Service Tool

INFOID:000000008633139

The actual shapes of the Kent-Moore tools may differ from those of the special service tools illustrated here.

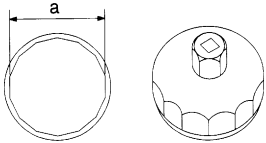
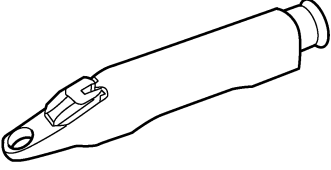
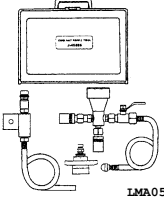
Tool number (Kent-Moore No.) Tool name	Description
KV10115801 (J-38956) Oil filter cap wrench <div style="text-align: center;">  <p>NE375</p> </div>	Removing and installing oil filter <b>a: 64.3 mm (2.531 in)</b>
KV991J0010 (J-23688) Engine coolant refractometer <div style="text-align: center;">  <p>WBIA0539E</p> </div>	Checking concentration of ethylene glycol in engine coolant
KV991J0070 (J-45695) Coolant refill tool <div style="text-align: center;">  <p>LMA053</p> </div>	Filling cooling system

#### Commercial Service Tool

INFOID:000000008633140

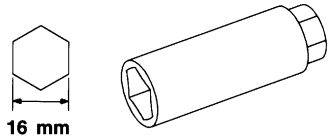
(Kent-Moore No.) Tool name	Description
Power tool <div style="text-align: center;">  <p>PIIB1407E</p> </div>	Loosening nuts, screws and bolts
Spark plug wrench <div style="text-align: center;">  <p>S-WT047</p> </div>	Removing and installing spark plug

A  
B  
C  
D  
E  
F  
G  
H  
I  
J  
K  
L  
M  
N  
O

MA

# GENERAL MAINTENANCE

< PERIODIC MAINTENANCE >

## PERIODIC MAINTENANCE

### GENERAL MAINTENANCE FOR USA AND CANADA

#### FOR USA AND CANADA : General Maintenance

INFOID:000000008633141

General maintenance includes those items which should be checked during the normal day-to-day operation of the vehicle. They are essential if the vehicle is to continue operating properly. The owner can perform these checks and inspections or have their NISSAN dealers perform them.

#### OUTSIDE THE VEHICLE

The maintenance items listed here should be performed from time to time, unless otherwise specified.

Item		Reference page
<b>Tires</b>	Check the pressure with a gauge often and always prior to a long distance trip. Adjust the pressure in all tires, including the spare, to the pressure specified. Check carefully for damage, cuts or excessive wear.	<a href="#">WT-49, "Inspection"</a>
<b>Wheel lug nuts</b>	When checking the tires, make sure no nuts are missing, and check for any loose nuts. Tighten if necessary.	<a href="#">WT-51, "Rotation"</a>
<b>Tire rotation</b>	Tires should be rotated every 7,500 miles (12,000 km).	<a href="#">WT-51, "Rotation"</a>
<b>Tire Pressure Monitoring System (TPMS) transmitter components</b>	Replace the TPMS transmitter grommet seat, valve core and cap when the tires are replaced due to wear or age.	<a href="#">WT-53, "Transmitter (Pressure Sensor)"</a>
<b>Wheel alignment and balance</b>	If the vehicle should pull to either side while driving on a straight and level road, or if you detect uneven or abnormal tire wear, there may be a need for wheel alignment. If the steering wheel or seat vibrates at normal highway speeds, wheel balancing may be needed. For additional information regarding tires, refer to "Important Tire Safety Information" (United States) or "Tire Safety Information" (Canada) in the NISSAN Warranty Information Booklet.	<a href="#">WT-50, "Balancing Wheels", FSU-6, "Front Wheel Alignment"</a>
<b>Windshield</b>	Clean the windshield on a regular basis. Check the windshield at least every six months for cracks or other damage. Repair as necessary.	—
<b>Windshield wiper blades</b>	Check for cracks or wear if they do not wipe properly.	<a href="#">WW-69, "Front Wiper Arms"</a>
<b>Doors and engine hood</b>	Check that all doors and the engine hood operate smoothly as well as the back door and rear glass hatch. Also make sure that all latches lock securely. Lubricate if necessary. Make sure that the secondary latch keeps the engine hood from opening when the primary latch is released. When driving in areas using road salt or other corrosive materials, check lubrication frequently.	<a href="#">MA-42, "LOCKS AND HINGES : Lubricating Locks, Hinges and Hood Latches"</a>
<b>Lamps</b>	Make sure that the head lamps, stop lamps, tail lamps, turn signal lamps, and other lamps are all operating properly and installed securely. Also check head lamp aim. Clean the head lamps on a regular basis.	<a href="#">EXL-131, "HEAD-LAMP : Aiming Adjustment"</a>

#### INSIDE THE VEHICLE

The maintenance items listed here should be checked on a regular basis, such as when performing periodic maintenance, cleaning the vehicle, etc.

Item		Reference page
<b>Warning lamps and chimes</b>	Make sure that all warning lamps and chimes are operating properly.	<a href="#">WCS-5, "WARNING CHIME SYSTEM : System Description"</a>
<b>Windshield wiper and washer</b>	Check that the windshield wipers and washer operate properly and that the wipers do not streak.	<a href="#">WW-69, "Front Wiper Arms"</a>
<b>Windshield defroster</b>	Check that the air comes out of the defroster outlets properly and in sufficient quantity when operating the heater or air conditioner.	—
<b>Steering wheel</b>	Check that it has the specified play. Check for changes in the steering condition, such as excessive play, hard steering or strange noises. Free play: Less than 35 mm (1.98 in)	<a href="#">ST-16, "On-Vehicle Inspection and Service"</a>

# GENERAL MAINTENANCE

## < PERIODIC MAINTENANCE >

Item		Reference page	
<b>Seats</b>	Check seat position controls such as seat adjusters, seatback recliner, etc. to make sure they operate smoothly and that all latches lock securely in every position. Check that the head restraints move up and down smoothly and that the locks (if equipped) hold securely in all latched positions. Check that the latches lock securely for folding-down rear seat backs.	<a href="#">SE-5, "Preliminary Check"</a>	A
<b>Seat belts</b>	Check that all parts of the seat belt system (e.g. buckles, anchors, adjusters and retractors) operate properly and smoothly and are installed securely. Check the belt webbing for cuts, fraying, wear or damage.	<a href="#">SB-4, "Inspection"</a>	B
<b>Accelerator pedal</b>	Check the pedal for smooth operation and make sure the pedal does not catch or require uneven effort. Keep the floor mats away from the pedal.	—	C
<b>Brakes</b>	Check that the brake does not pull the vehicle to one side when applied.	—	D
<b>Brake pedal and booster</b>	Check the pedal for smooth operation and make sure it has the proper distance under it when depressed fully. Check the brake booster function. Be sure to keep the floor mats away from the pedal.	<a href="#">BR-14, "Inspection and Adjustment"</a> , <a href="#">BR-9, "Inspection"</a>	E
<b>Parking brake</b>	Check that the lever or the pedal has the proper travel and make sure that the vehicle is held securely on a fairly steep hill when only the parking brake is applied.	<a href="#">PB-5, "On-Vehicle Service"</a>	F
<b>Automatic transmission "Park" mechanism</b>	On a fairly steep hill check that the vehicle is held securely with the selector lever in the P (Park) position without applying the brakes.	—	G

### UNDER THE HOOD AND VEHICLE

The maintenance items listed here should be checked periodically (e.g. each time you check the engine oil or refuel).

Item		Reference page	
<b>Windshield washer fluid</b>	Check that there is adequate fluid in the tank.	—	H
<b>Engine coolant level</b>	Check the coolant level when the engine is cold.	<a href="#">CO-10, "Inspection"</a>	I
<b>Radiator and hoses</b>	Check the front of the radiator and clean off any dirt, insects, leaves, etc., that may have accumulated. Make sure the hoses have no cracks, deformation, deterioration or loose connections.	—	J
<b>Brake fluid level</b>	Make sure that the brake fluid level is between the "MAX" and "MIN" lines on the reservoir.	<a href="#">MA-38, "BRAKE FLUID LEVEL AND LEAKS : On Board Inspection"</a>	K
<b>Battery</b>	Check the fluid level in each cell. It should be between the "MAX" and "MIN" lines. Vehicles operated in high temperatures or under severe conditions require frequent checks of the battery fluid level.	—	L
<b>Engine drive belt</b>	Make sure that no belt is frayed, worn, cracked or oily.	<a href="#">MA-21, "DRIVE BELTS : Checking Drive Belts"</a>	M
<b>Engine oil level</b>	Check the level on the oil level gauge after parking the vehicle on a level spot and turning off the engine.	<a href="#">MA-25, "ENGINE OIL : Inspection"</a>	N
<b>Power steering fluid level and lines</b>	Check the level when the fluid is cold, with the engine off. Check the lines for proper attachment, leaks, cracks, etc.	<a href="#">MA-40, "POWER STEERING FLUID AND LINES : Checking Fluid Level"</a>	O
<b>Automatic transmission fluid level</b>	Check the level on the fluid level gauge after putting the selector lever in "P" with the engine idling.	<a href="#">MA-34, "TRANSFER FLUID : Inspection"</a>	MA
<b>Exhaust system</b>	Make sure there are no loose supports, cracks or holes. If the sound of the exhaust seems unusual or there is a smell of exhaust fumes, immediately locate the trouble and correct it.	<a href="#">MA-29, "EXHAUST SYSTEM : Checking Exhaust System"</a>	

# GENERAL MAINTENANCE

## < PERIODIC MAINTENANCE >

Item		Reference page
<b>Underbody</b>	The underbody is frequently exposed to corrosive substances such as those used on icy roads or to control dust. It is very important to remove these substances, otherwise rust will form on the floor pan, frame, fuel lines and around the exhaust system. At the end of winter, the underbody should be thoroughly flushed with plain water, being careful to clean those areas where mud and dirt can easily accumulate.	—
<b>Fluid leaks</b>	Check under the vehicle for fuel, oil, water or other fluid leaks after the vehicle has been parked for a while. Water dripping from the air conditioner after use is normal. If you should notice any leaks or gasoline fumes are evident, check for the cause and correct it immediately.	—

## FOR MEXICO

### FOR MEXICO : General Maintenance

INFOID:000000008633142

General maintenance includes those items which should be checked during the normal day-to-day operation of the vehicle. They are essential if the vehicle is to continue operating properly. The owner can perform the checks and inspections themselves or they can have their NISSAN dealers do them.

### OUTSIDE THE VEHICLE

The maintenance items listed here should be performed from time to time, unless otherwise specified.

Item		Reference page
<b>Doors and engine hood</b>	Check that all doors and the engine hood operate smoothly as well as the back door, trunk lid and hatch. Also make sure that all latches lock securely. Lubricate if necessary. Make sure that the secondary latch keeps the hood from opening when the primary latch is released. When driving in areas using road salt or other corrosive materials, check lubrication frequently.	<a href="#">MA-42</a>
<b>Lamps</b>	Clean the headlamps on a regular basis. Make sure that the headlamps, stop lamps, tail lamps, turn signal lamps, and other lamps are all operating properly and installed securely. Also check the aim of the headlamps.	—
<b>Tires</b>	Check the pressure with a gauge often and always prior to long distance trips. Adjust the pressure in all tires, including the spare, to the pressure specified. Check carefully for damage, cuts or excessive wear.	<a href="#">WT-49. "Inspection"</a>
<b>Tire rotation</b>	In the case that Two-Wheel Drive (2WD) and front & rear tires are same size; Tires should be rotated every 10,000 km (6,000 miles). Tires marked with directional indicators can only be rotated between front and rear. Make sure that the directional indicators point in the direction of wheel rotation after the tire rotation is completed. In the case that Four-Wheel Drive (4WD) and front & rear tires are same size; Tires should be rotated every 5,000 km (3,000 miles). Tires marked with directional indicators can only be rotated between front and rear. Make sure that the directional indicators point in the direction of wheel rotation after the tire rotation is completed. In the case that front tires are different size from rear tires; Tires cannot be rotated. However, the timing for tire rotation may vary according to your driving habits and the road surface conditions.	<a href="#">WT-51. "Rotation"</a>
<b>Tire Pressure Monitoring System (TPMS) transmitter components (if equipped)</b>	Replace the TPMS transmitter grommet seal, valve core and cap when the tires are replaced due to wear or age.	<a href="#">WT-53. "Transmitter (Pressure Sensor)"</a>
<b>Wheel alignment and balance</b>	If the vehicle should pull to either side while driving on a straight and level road, or if you detect uneven or abnormal tire wear, there may be a need for wheel alignment. If the steering wheel or seat vibrates at normal highway speeds, wheel balancing may be needed.	<a href="#">FSU-6</a> <a href="#">FSU-6</a> <a href="#">FSU-6</a>
<b>Windshield</b>	Clean the windshield on a regular basis. Check the windshield at least every six months for cracks or other damage. Repairs necessary.	—
<b>Wiper blades</b>	Check for cracks or wear if not functioning correctly.	—

### INSIDE THE VEHICLE



# GENERAL MAINTENANCE

## < PERIODIC MAINTENANCE >

The maintenance items listed here should be checked on a regular basis, such as when performing periodic maintenance, cleaning the vehicle, etc.

Item		Reference page
<b>Accelerator pedal</b>	Check the pedal for smooth operation and make sure that the pedal does not catch or require uneven effort. Keep the floor mats away from the pedal.	—
<b>Brake pedal</b>	Check the pedal for smooth operation and make sure that it attains the proper distance from the floor mat when depressed fully. Check the brake booster function. Be sure to keep the floor mats away from the pedal.	<a href="#">BR-14. "Inspection and Adjustment"</a>
<b>Parking brake</b>	Check the parking brake operation regularly. Check that the lever (if equipped) or the pedal (if equipped) has the proper travel. Also make sure that the vehicle is held securely on a fairly steep hill when only the parking brake is applied.	<a href="#">PB-5. "On-Vehicle Service"</a>
<b>Seat belts</b>	Check that all parts of the seat belt system (for example, buckles, anchors, adjusters and retractors) operate properly and smoothly, and are installed securely. Check the belt webbing for cuts, fraying, wear or damage.	<a href="#">SB-4. "Inspection"</a>
<b>Steering wheel</b>	Check for changes in the steering condition, such as excessive play, hard steering or strange noises. Check that it has the specified play. <b>Free play: Less than 35 mm (1.38 in)</b>	—
<b>Warning lamps and chimes</b>	Make sure that all warning lamps and chimes are operating properly.	—
<b>Windshield defogger</b>	Check that the air comes out of the defogger outlets properly and in good quantity when operating the heater or air conditioner.	—
<b>Windshield wiper and washer</b>	Check that the wipers and washer operate properly and that the wipers do not streak.	—

## UNDER THE HOOD AND VEHICLE

The maintenance items listed here should be checked periodically (for example, each time you check the engine oil or refuel.)

Item		Reference page
<b>Battery</b>	Except for maintenance free battery; Check the fluid level in each cell. It should be between the "UPPER" and "LOWER" lines. Vehicles operated in high temperatures or under severe conditions require frequent checks of the battery fluid level.	<a href="#">PG-5. "How to Handle Battery"</a>
<b>Brake (and clutch) fluid level(s)</b>	For Manual Transmission (MT) model; Make sure that the brake and clutch fluid levels are between the "MAX" and "MIN" lines on the reservoir(s). Except for Manual Transmission (MT) model; Make sure that the brake fluid level is between the "MAX" and "MIN" lines on the reservoir.	<a href="#">BR-16. "Drain and Refill"</a>
<b>Engine coolant level</b>	Check the coolant level when the engine is cold. Make sure that the coolant level is between the "MAX" and "MIN" lines on the reservoir.	<a href="#">CO-10. "Inspection"</a>
<b>Engine drive belt(s)</b>	Make sure that drive belt(s) is/are not frayed, worn, cracked or oily.	<a href="#">EM-14. "Checking Drive Belts"</a>
<b>Engine oil level</b>	Check the level after parking the vehicle (on a level ground) and turning off the engine.	<a href="#">LU-8. "Inspection"</a>
<b>Fluid leaks</b>	Check under the vehicle for fuel, oil, water or other fluid leaks after the vehicle has been parked for a while. Water dripping from the air conditioner after use is normal. If you should notice any leaks or if fuel fumes are evident, check for cause and have it corrected immediately.	—
<b>Power steering fluid level and lines</b>	Check the level when the fluid is cold with the engine off. Check the lines for proper attachment, leaks, cracks, etc.	<a href="#">ST-13. "Checking Fluid Level"</a>
<b>Windshield washer fluid</b>	Check that there is adequate fluid in the reservoir tank.	—

A  
B  
C  
D  
E  
F  
G  
H  
I  
J  
K  
L  
M  
N  
O

MA

# PERIODIC MAINTENANCE

< PERIODIC MAINTENANCE >

## PERIODIC MAINTENANCE FOR USA AND CANADA

### FOR USA AND CANADA : Introduction of Periodic Maintenance

INFOID:000000008633143

Two different maintenance schedules are provided, and should be used, depending upon the conditions in which the vehicle is mainly operated. **After 60,000 miles (96,000 km) or 48 months, continue the periodic maintenance at the same mileage or time intervals, whichever comes first.**

Schedule 1	Follow Periodic Maintenance Schedule 1 if your driving habits frequently includes one or more of the following driving conditions: <ul style="list-style-type: none"> <li>• Repeated short trips of less than 5 miles (8 km).</li> <li>• Repeated short trips of less than 10 miles (16 km) with outside temperatures remaining below freezing.</li> <li>• Operating in hot weather in stop-and-go "rush hour" traffic.</li> <li>• Extensive idling and/or low speed driving for long distances, such as police, taxi or door-to-door delivery use.</li> <li>• Driving in dusty conditions.</li> <li>• Driving on rough, muddy, or salt spread roads.</li> <li>• Towing a trailer or using a camper or car-top carrier.</li> </ul>	Emission Control System Maintenance	<a href="#">MA-10</a>
		Chassis and Body Maintenance	<a href="#">MA-10</a>
Schedule 2	Follow Periodic Maintenance Schedule 2 if none of the driving conditions shown in Schedule 1 apply to the driving habits.	Emission Control System Maintenance	<a href="#">MA-12</a>
		Chassis and Body Maintenance	<a href="#">MA-12</a>

#### Maintenance for off-road driving (4WD only)

After driving the vehicle off-road through sand, mud, or water; more frequent maintenance may be required for the following items:

- ▲ Brake pads and rotors
- ▲ Brake lines and hoses
- ▲ Differential, transfer gear oil and automatic transmission fluid
- ▲ Steering linkage
- ▲ Drive shafts
- ▲ Engine air cleaner filter
- ▲ In-cabin microfilters

### FOR USA AND CANADA : Schedule 1

INFOID:000000008633144

#### EMISSION CONTROL SYSTEM MAINTENANCE

Abbreviations: R = Replace. I = Inspect. Correct or replace if necessary. [ ] : At the mileage intervals only

MAINTENANCE OPERATION		MAINTENANCE INTERVAL								Reference Section - Page or - Content Title
Perform at number of miles, kilometers or months, whichever comes first.	Miles x 1,000 (km x 1,000) Months	3.75 (6) 3	7.50 (12) 6	11.25 (18) 9	15 (24) 12	18.75 (30) 15	22.5 (36) 18	26.25 (42) 21	30 (48) 24	
Drive belts	NOTE (1)									<a href="#">MA-21</a>
Air cleaner filter	NOTE (2)								[R]	<a href="#">MA-24</a>
EVAP vapor lines									I*	<a href="#">MA-28</a>
Fuel lines									I*	<a href="#">MA-24</a>
Fuel filter	NOTE (3)									<a href="#">MA-24</a>
Engine coolant*	NOTE (4)(5)									<a href="#">MA-21</a>
Engine oil		R	R	R	R	R	R	R	R	<a href="#">MA-25</a>
Engine oil filter		R	R	R	R	R	R	R	R	<a href="#">MA-26</a>
Spark plugs (Iridium-tipped type)		Replace every 105,000 miles (168,000 km).								<a href="#">MA-27</a>
Intake and exhaust valve clearance*	NOTE (6)									<a href="#">EM-118</a>

# PERIODIC MAINTENANCE

## < PERIODIC MAINTENANCE >

MAINTENANCE OPERATION		MAINTENANCE INTERVAL								Reference Section - Page or - Content Title
		Miles x 1,000 (54) 27	37.5 (60) 30	41.25 (66) 33	45 (72) 36	48.75 (78) 39	52.5 (84) 42	56.25 (90) 45	60 (96) 48	
Perform at number of miles, kilometers or months, whichever comes first.	Miles x 1,000 (km x 1,000) Months	33.75 (54) 27	37.5 (60) 30	41.25 (66) 33	45 (72) 36	48.75 (78) 39	52.5 (84) 42	56.25 (90) 45	60 (96) 48	
Drive belts	NOTE (1)								I*	<a href="#">MA-21</a>
Air cleaner filter	NOTE (2)								[R]	<a href="#">MA-24</a>
EVAP vapor lines									I*	<a href="#">MA-28</a>
Fuel lines									I*	<a href="#">MA-24</a>
Fuel filter	NOTE (3)									<a href="#">MA-24</a>
Engine coolant*	NOTE (4)(5)									<a href="#">MA-21</a>
Engine oil		R	R	R	R	R	R	R	R	<a href="#">MA-25</a>
Engine oil filter		R	R	R	R	R	R	R	R	<a href="#">MA-26</a>
Spark plugs (Iridium-tipped type)		Replace every 105,000 miles (168,000 km).								<a href="#">MA-27</a>
Intake and exhaust valve clearance*	NOTE (6)									<a href="#">EM-118</a>

### NOTE:

- (1) After 60,000 miles (96,000 km) or 48 months, inspect every 15,000 miles (24,000 km) or 12 months. Replace the drive belts if found damaged or if the auto belt tensioner reading reaches the maximum limit.
- (2) If operating mainly in dusty conditions, more frequent maintenance may be required.
- (3) Maintenance-free item. For service procedures, refer to the FL section.
- (4) First replacement interval is 105,000 miles (168,000 km) or 84 months. After first replacement, replace every 75,000 miles (120,000 km) or 60 months.
- (5) When adding or replacing coolant, be sure to use only Genuine NISSAN Long Life Antifreeze/Coolant (blue) or equivalent. Genuine Nissan Long Life Antifreeze/Coolant (blue) is pre-diluted to provide antifreeze protection to -34°F (-37°C). If additional freeze protection is needed due to weather where you operate your vehicle, add Genuine NISSAN Long Life Antifreeze/Coolant (blue) concentration following the directions on the container. If an equivalent coolant other than Genuine NISSAN Long Life Antifreeze/Coolant (blue) is used, follow the coolant manufacturer's instructions to maintain minimum antifreeze protection to -34°F (-37°C). The use of other types or coolant solutions other than Genuine NISSAN Long Life Antifreeze/Coolant (blue) or equivalent may damage the engine cooling system.
- (6) Periodic maintenance is not required. However, if valve noise increases, inspect valve clearance.

\* Maintenance items and intervals with "\*" are recommended by NISSAN for reliable vehicle operation. The owner need not perform such maintenance in order to maintain the emission warranty or manufacturer recall liability. Other maintenance items and intervals are required.

## CHASSIS AND BODY MAINTENANCE

Abbreviations: R = Replace. I = Inspect. Correct or replace if necessary. L = Lubricate. [ ]: At the mileage intervals only.

MAINTENANCE OPERATION		MAINTENANCE INTERVAL								Reference Section - Page or - Content Title
		Miles x 1,000 (6) 3	7.5 (12) 6	11.25 (18) 9	15 (24) 12	18.75 (30) 15	22.5 (36) 18	26.25 (42) 21	30 (48) 24	
Perform at number of miles, kilometers or months, whichever comes first.	Miles x 1,000 (km x 1,000) Months	3.75 (6) 3	7.5 (12) 6	11.25 (18) 9	15 (24) 12	18.75 (30) 15	22.5 (36) 18	26.25 (42) 21	30 (48) 24	
Brake lines and cables					I				I	<a href="#">MA-38</a>
Brake fluid					R				R	<a href="#">MA-38</a>
Brake pads and rotors			I		I		I		I	<a href="#">MA-38</a> , <a href="#">MA-39</a>
Automatic transmission fluid, transfer fluid and differential gear oil	NOTE (1)				I				I	<a href="#">MA-30</a> , <a href="#">MA-34</a> , <a href="#">MA-35</a> , <a href="#">MA-35</a>
Steering gear and linkage, axle and suspension parts			I		I		I		I	<a href="#">MA-39</a> , <a href="#">MA-40</a>
Tire rotation	NOTE (2)									<a href="#">MA-37</a>

# PERIODIC MAINTENANCE

## < PERIODIC MAINTENANCE >

MAINTENANCE OPERATION		MAINTENANCE INTERVAL								Reference Section - Page or - Content Title
	Miles x 1,000 (km x 1,000) Months	3.75 (6) 3	7.5 (12) 6	11.25 (18) 9	15 (24) 12	18.75 (30) 15	22.5 (36) 18	26.25 (42) 21	30 (48) 24	
Perform at number of miles, kilometers or months, whichever comes first.										
Drive shaft boots and propeller shaft (4WD)			I		I		I		I	<a href="#">MA-34</a>
Exhaust system			I		I		I		I	<a href="#">MA-29</a>
In-cabin microfilter					R				R	<a href="#">MA-29</a>

MAINTENANCE OPERATION		MAINTENANCE INTERVAL								Reference Section - Page or - Content Title
	Miles x 1,000 (km x 1,000) Months	33.75 (54) 27	37.5 (60) 30	41.25 (66) 33	45 (72) 36	48.75 (78) 39	52.5 (84) 42	56.25 (90) 45	60 (96) 48	
Perform at number of miles, kilometers or months, whichever comes first.										
Brake lines and cables					I				I	<a href="#">MA-38</a>
Brake fluid					R				R	<a href="#">MA-38</a>
Brake pads and rotors			I		I		I		I	<a href="#">MA-38</a> , <a href="#">MA-39</a>
Automatic transmission fluid, transfer fluid and differential gear oil	NOTE (1)				I				I	<a href="#">MA-30</a> , <a href="#">MA-34</a> , <a href="#">MA-35</a>
Steering gear and linkage, axle and suspension parts			I		I		I		I	<a href="#">MA-39</a> , <a href="#">MA-40</a>
Tire rotation	NOTE (2)									<a href="#">MA-37</a>
Drive shaft boots and propeller shaft (4WD)			I		I		I		I	<a href="#">MA-34</a>
Exhaust system			I		I		I		I	<a href="#">MA-29</a>
In-cabin microfilter					R				R	<a href="#">MA-29</a>

**NOTE:**

(1) If towing a trailer, using a camper or car-top carrier, or driving on rough or muddy roads, change (not just inspect) oil/fluid at every 30,000 miles (48,000 km) or 24 months. **Using automatic transmission fluid other than Genuine NISSAN Matic S ATF or Matic J ATF will cause deterioration in driveability and automatic transmission durability, and may damage the automatic transmission, which is not covered by the NISSAN new vehicle limited warranty.**

(2) Refer to "Tire rotation" under the "General maintenance" heading earlier in this section.

## FOR USA AND CANADA : Schedule 2

INFOID:000000008633145

## EMISSION CONTROL SYSTEM MAINTENANCE

Abbreviations: R = Replace. I = Inspect. Correct or replace if necessary. [ ] : At the mileage intervals only

MAINTENANCE OPERATION		MAINTENANCE INTERVAL								Reference Section - Page or - Content Title
	Miles x 1,000 (km x 1,000) Months	7.5 (12) 6	15 (24) 12	22.5 (36) 18	30 (48) 24	37.5 (60) 30	45 (72) 36	52.5 (84) 42	60 (96) 48	
Perform at number of miles, kilometers or months, whichever comes first.										
Drive belts	NOTE (1)								I*	<a href="#">MA-21</a>
Air cleaner filter					[R]				[R]	<a href="#">MA-24</a>
EVAP vapor lines					I*				I*	<a href="#">MA-28</a>
Fuel lines					I*				I*	<a href="#">MA-24</a>
Fuel filter	NOTE (2)									<a href="#">MA-24</a>
Engine coolant*	NOTE (3)(4)									<a href="#">MA-21</a>
Engine oil (Except for FFV models)		R	R	R	R	R	R	R	R	<a href="#">MA-25</a>
Engine oil (For FFV models)		Replace every 3,750 miles (6,000 km) or 3 months.								<a href="#">MA-25</a>

# PERIODIC MAINTENANCE

## < PERIODIC MAINTENANCE >

MAINTENANCE OPERATION	Miles x 1,000 (km x 1,000) Months	MAINTENANCE INTERVAL								Reference Section - Page or - Content Title
		7.5 (12) 6	15 (24) 12	22.5 (36) 18	30 (48) 24	37.5 (60) 30	45 (72) 36	52.5 (84) 42	60 (96) 48	
Perform at number of miles, kilometers or months, whichever comes first.										
Engine oil filter (Except for FFV models)		R	R	R	R	R	R	R	R	<a href="#">MA-26</a>
Engine oil filter (For FFV models)		Replace every 3,750 miles (6,000 km) or 3 months.								<a href="#">MA-26</a>
Spark plugs (Iridium - tipped type)		Replace every 105,000 miles (168,000 km)								<a href="#">MA-27</a>
Intake and exhaust valve clearance*	NOTE (5)									<a href="#">EM-19</a>

**NOTE:**

- (1) After 60,000 miles (96,000 km) or 48 months, inspect every 15,000 miles (24,000 km) or 12 months. Replace the drive belts if found damaged or if the auto belt tensioner reading reaches the maximum limit.
- (2) Maintenance-free item. For service procedures, refer to FL section.
- (3) First replacement interval is 105,000 miles (168,000 km) or 84 months. After first replacement, replace every 75,000 miles (120,000 km) or 60 months.
- (4) When adding or replacing coolant, be sure to use only Genuine NISSAN Long Life Antifreeze/Coolant (blue) or equivalent. Genuine Nissan Long Life Antifreeze/Coolant (blue) is pre-diluted to provide antifreeze protection to -34°F (-37°C). If additional freeze protection is needed due to weather where you operate your vehicle, add Genuine NISSAN Long Life Antifreeze/Coolant (blue) concentration following the directions on the container. If an equivalent coolant other than Genuine NISSAN Long Life Antifreeze/Coolant (blue) is used, follow the coolant manufacturer's instructions to maintain minimum antifreeze protection to -34°F (-37°C). The use of other types or coolant solutions other than Genuine NISSAN Long Life Antifreeze/Coolant (blue) or equivalent may damage the engine cooling system.
- (5) Periodic maintenance is not required. However, if valve noise increases, inspect valve clearance.

\* Maintenance items and intervals with "\*" are recommended by NISSAN for reliable vehicle operation. The owner need not perform such maintenance in order to maintain the emission warranty or manufacturer recall liability. Other maintenance items and intervals are required.

## CHASSIS AND BODY MAINTENANCE

Abbreviations: R = Replace. I = Inspect. Correct or replace if necessary.

MAINTENANCE OPERATION	Miles x 1,000 (km x 1,000) Months	MAINTENANCE INTERVAL								Reference Section - Page or - Content Title
		7.5 (12) 6	15 (24) 12	22.5 (36) 18	30 (48) 24	37.5 (60) 30	45 (72) 36	52.5 (84) 42	60 (96) 48	
Perform at number of miles, kilometers or months, whichever comes first.										
Brake lines and cables			I		I		I		I	<a href="#">MA-38</a>
Brake fluid					R				R	<a href="#">MA-38</a>
Brake pads and rotors			I		I		I		I	<a href="#">MA-38</a> , <a href="#">MA-39</a>
Automatic transmission fluid, transfer fluid and differential gear oil	NOTE (1)		I		I		I		I	<a href="#">MA-30</a> <a href="#">MA-34</a> , <a href="#">MA-35</a> , <a href="#">MA-35</a>
Steering gear and linkage, axle and suspension parts.					I				I	<a href="#">MA-39</a> , <a href="#">MA-40</a>
Tire rotation	NOTE (2)									<a href="#">MA-37</a>
Drive shaft boots and propeller shaft (4WD)			I		I		I		I	<a href="#">MA-34</a>
Exhaust system					I				I	<a href="#">MA-29</a>
In-cabin microfilter			R		R		R		R	<a href="#">MA-29</a>

**NOTE:**

- (1) Using automatic transmission fluid other than Genuine NISSAN Matic S ATF or Matic J ATF will cause deterioration in driveability and automatic transmission durability, and may damage the automatic transmission, which is not covered by the NISSAN new vehicle limited warranty.
- (2) Refer to "Tire rotation" under the "General maintenance" heading earlier in this section.

## FOR MEXICO

# PERIODIC MAINTENANCE

< PERIODIC MAINTENANCE >

## FOR MEXICO : Introduction of Periodic Maintenance

INFOID:000000008633146

The following tables show the normal maintenance schedule. Depending upon weather and atmospheric conditions, varying road surfaces, individual driving habits and vehicle usage, additional or more frequent maintenance may be required.

**Periodic maintenance beyond the last period shown on the tables requires similar maintenance.**

### ENGINE AND EMISSION CONTROL MAINTENANCE

Abbreviations: I = Inspect and correct or replace as necessary, R = Replace, E = Check and correct the engine coolant mixture ratio

MAINTENANCE OPERATION		MAINTENANCE INTERVAL								Reference page
Perform either at number of kilometers (miles) or months, whichever comes first.	km x 1,000 (Miles x 1,000) Months	10 (6) 6	20 (12) 12	30 (18) 18	40 (24) 24	50 (30) 30	60 (36) 36	70 (42) 42	80 (48) 48	
<b>Engine compartment and under vehicle</b>										
Intake & exhaust valve clearance	NOTE (1)									<a href="#">EM-19</a>
Drive belts	NOTE (2)				I				I	<a href="#">MA-21</a>
Engine oil (Use recommended oil.)★		R	R	R	R	R	R	R	R	<a href="#">LU-9</a>
Engine oil filter (Use Genuine NISSAN engine oil filter or equivalent.)★		R	R	R	R	R	R	R	R	<a href="#">LU-11</a>
Engine coolant	NOTE (3)				E				E	<a href="#">CO-11</a>
Cooling system					I				I	<a href="#">CO-10</a>
Fuel lines					I				I	<a href="#">FL-6</a>
Air cleaner filter (Viscous paper type)★					R				R	<a href="#">EM-16</a>
Fuel filter (In-tank type)	NOTE (4)									—
Spark plugs (Iridium-tipped type)		Replace every 100,000 km (60,000 miles)								<a href="#">EM-17</a>
EVAP vapor lines (with carbon canister)					I				I	<a href="#">MA-28</a>

**NOTE:**

- (1) Periodic maintenance is not required. However, if valve noise increases, check valve clearance.
- (2) Replace the drive belts if found damaged or if the drive belt auto-tensioner reading reaches the maximum limit.
- (3) Use Genuine NISSAN Engine Coolant or equivalent in its quality, in order to avoid possible aluminum corrosion within the engine cooling system caused by the use of non-genuine engine coolant. Check and correct the engine coolant mixture ratio every 40,000 km (24,000 miles) or 24 months. First replacement interval is 160,000 km (96,000 miles) or 96 months. After first replacement, replace every 80,000 km (48,000 miles) or 48 months.
- (4) Fuel filter is maintenance-free. For service procedures, refer to FL section.

• ★ Maintenance items with “★” should be performed more frequently according to “Maintenance Under Severe Driving Conditions”.

### CHASSIS AND BODY MAINTENANCE

Abbreviations: I = Inspect and correct or replace as necessary, R = Replace, Lubricate

MAINTENANCE OPERATION		MAINTENANCE INTERVAL								Reference page
Perform either at number of kilometers (miles) or months, whichever comes first.	km x 1,000 (Miles x 1,000) Months	10 (6) 6	20 (12) 12	30 (18) 18	40 (24) 24	50 (30) 30	60 (36) 36	70 (42) 42	80 (48) 48	
<b>Underhood and under vehicle</b>										
Brake and automatic transmission fluid (For level & leaks)★			I		I		I		I	<a href="#">BR-16, TM-158</a>
Brake Fluid★					R				R	<a href="#">BR-16</a>
Power steering fluid & lines (For level & leaks)			I		I		I		I	<a href="#">ST-13</a>

# PERIODIC MAINTENANCE

< PERIODIC MAINTENANCE >

MAINTENANCE OPERATION		MAINTENANCE INTERVAL								Reference page
		10 (6) 6	20 (12) 12	30 (18) 18	40 (24) 24	50 (30) 30	60 (36) 36	70 (42) 42	80 (48) 48	
Perform either at number of kilometers (miles) or months, whichever comes first.	km x 1,000 (Miles x 1,000) Months									
Brake lines & cable			I		I		I		I	<a href="#">EX-5</a>
Exhaust system					I				I	<a href="#">EX-5</a>
Transfer gear fluid (For level & leaks)			I		I		I		I	<a href="#">DLN-128</a>
Differential gear oil (For level & leaks)★			I		I		I		I	<a href="#">DLN-208</a> , <a href="#">DLN-242</a>
Steering gear & linkage, axle & suspension parts★					I				I	<a href="#">ST-13</a> , <a href="#">FSU-6</a>
Propeller shaft & drive shafts★			I		I		I		I	<a href="#">DLN-193</a>
<b>Outside and inside</b>										
Wheel alignment (If necessary, rotate & balance wheels)			I		I		I		I	<a href="#">FSU-6</a> , <a href="#">RSU-6</a>
Brake pads, rotors & drums & linings★			I		I		I		I	<a href="#">BR-7</a> , <a href="#">BR-8</a>
Foot brake & parking brake (For free play, stroke & operation)			I		I		I		I	<a href="#">BR-14</a> , <a href="#">PB-5</a>
Air conditioner filter★			R		R		R		R	<a href="#">MA-29</a>

**NOTE:**

★ Maintenance items with “★” should be performed more frequently according to “Maintenance Under Severe Driving Conditions”.

## MAINTENANCE UNDER SEVERE DRIVING CONDITIONS

The maintenance intervals shown on the preceding pages are for normal operating conditions. If the vehicle is mainly operated under severe driving conditions as shown below, more frequent maintenance must be performed on the following items as shown in the table.

### Severe driving conditions

- A — Driving under dusty conditions
- B — Repeatedly driving short distances
- C — Towing a trailer or caravan
- D — Extensive idling
- E — Driving in extremely adverse weather conditions or in areas where ambient temperatures are either extremely low or extremely high
- F — Driving in high humidity or mountainous areas
- G — Driving in areas using salt or other corrosive materials
- H — Driving on rough and/or muddy roads or in the desert
- I — Driving with frequent use of braking or in mountainous areas

Maintenance operation: Check = Check and correct or replace as necessary.

Driving condition									Maintenance item	Maintenance operation	Maintenance interval	Reference page
A	.	.	.	.	.	.	.	.	Air cleaner filter	Replace	More frequently	<a href="#">MA-24</a>
A	B	C	D	.	.	.	.	.	Engine oil & engine oil filter	Replace	Every 5,000 km (3,000 miles) or 3 months	<a href="#">MA-25</a> , <a href="#">MA-26</a>
.	.	.	.	.	F	.	.	.	Brake fluid	Replace	Every 20,000 km (12,000 miles) or 12 months	<a href="#">MA-38</a>
.	.	C	.	.	.	.	.	H	Automatic transmission fluid	Replace	Every 40,000 km (24,000 miles) or 24 months	<a href="#">MA-32</a>
.	.	C	.	.	.	.	.	H	Differential gear oil	Replace	Every 40,000 km (24,000 miles) or 24 months	<a href="#">MA-35</a>

## PERIODIC MAINTENANCE

< PERIODIC MAINTENANCE >

.	.	.	.	.	.	G	H	.	Steering gear & linkage, axle & suspension parts	Inspect	Every 20,000 km (12,000 miles) or 12 months	<a href="#">MA-39</a> , <a href="#">MA-40</a>
.	.	.	.	.	.	G	H	.	Propeller shaft & drive shafts	Inspect	Every 10,000 km (6,000 miles) or 6 months	<a href="#">MA-34</a>
A	.	C	.	.	.	G	H	I	Brake pads, rotors, drums & linings	Inspect	Every 10,000 km (6,000 miles) or 6 months	<a href="#">MA-38</a> , <a href="#">MA-39</a>
A	.	.	.	.	.	.	.	.	Air conditioner filter	Replace	More frequently	<a href="#">MA-29</a>

### Maintenance for off-road driving (4WD only)

Whenever you drive off-road through sand, mud or water, more frequent maintenance may be required of the following items.

- Brake pads and rotors
- Brake lines and hoses
- Differential gear oil, transfer fluid and automatic transmission fluid
- Steering linkage
- Propeller shafts and front drive shafts
- Air cleaner filter



# RECOMMENDED FLUIDS AND LUBRICANTS

< PERIODIC MAINTENANCE >

## RECOMMENDED FLUIDS AND LUBRICANTS FOR USA AND CANADA

FOR USA AND CANADA : Fluids and Lubricants

INFOID:000000008633147

Description		Capacity (Approximate)			Recommended Fluids/Lubricants
		Metric	US measure	Imp measure	
Fuel		105.8 ℓ	28 gal	23-1/4 gal	Unleaded gasoline with an octane rating of at least 87 AKI (RON 91), or E-85 Ethanol fuel for Flexible Fuel Vehicles (FFV) *7
Engine oil Drain and refill	With oil filter change	6.5 ℓ	6-7/8 qt	5-3/4 qt	<ul style="list-style-type: none"> <li>• Engine oil with API Certification Mark*1</li> <li>• Viscosity SAE 5W-30</li> </ul>
	Without oil filter change	6.2 ℓ	6-1/2 qt	5-1/2 qt	
Dry engine (engine overhaul)		7.6 ℓ	8 qt	6-3/4 qt	
Cooling system	With reservoir at MAX level	14.4 ℓ	15-1/4 qt	12-5/8 qt	Pre-diluted Genuine NISSAN Long Life Anti-freeze coolant (blue) or equivalent
Automatic transmission fluid (ATF)		10.6 ℓ	11-1/4 qt	9-3/8 qt	Genuine NISSAN Matic S ATF*2
Rear differential gear oil		1.75 ℓ	3-3/4 pt	3-1/8 pt	API GL-5 synthetic gear oil, Viscosity SAE 75W-90 *6
Transfer fluid		3.0 ℓ	3-1/8 qt	2-5/8 qt	Genuine NISSAN Matic D recommended *9
Front differential gear oil		1.6 ℓ	3-3/8 pt	2-7/8 pt	Genuine NISSAN Differential Oil Super GL-5 80W-90 or API GL-5 Viscosity SAE 80W-90 *8
Power steering fluid (PSF)		1.0 ℓ	1-1/8 qt	7/8 qt	Genuine NISSAN PSF or equivalent*3
Brake fluid		—	—	—	Genuine NISSAN Super Heavy Duty Brake Fluid *4 or equivalent, DOT 3 (US FMVSS No. 116)
Multi-purpose grease		—	—	—	NLGI No. 2 (lithium soap base)
Windshield washer fluid		4.5 ℓ	4-3/4 qt	4 qt	Genuine NISSAN Windshield Washer Concentrate Cleaner & Anti-freeze or equivalent
Air conditioning system refrigerant		1.08 ± 0.05 kg	2.38 ± 0.11 lb	2.38 ± 0.11 lb	HFC-134a (R-134a)*5
Air conditioning system oil		290 m ℓ	9.8 fl oz	10.2 fl oz	A/C System Oil Type S (DH-PS)*5

\*1: For further details, refer to [MA-17, "FOR USA AND CANADA : Engine Oil Recommendation"](#).

\*2: If Genuine NISSAN Matic S ATF is not available, Genuine Matic J ATF may also be used. Using automatic transmission fluid other than Genuine NISSAN Matic S ATF or Matic J ATF will cause deterioration in driveability and automatic transmission durability, and may damage the automatic transmission, which is not covered by the NISSAN new vehicle limited warranty.

\*3: DEXRON™ VI type ATF may also be used.

\*4: Available in mainland U.S.A. through a NISSAN dealer.

\*5: For further details, see "Air conditioner specification label".

\*6: See a NISSAN dealer for service for synthetic oil.

\*7: For further details, refer to [GI-30, "Fuel \(Regular Unleaded Gasoline Recommended\)"](#).

\*8: For hot climates, Viscosity SAE 90 is suitable for ambient temperatures above 0°C (32°F).

\*9: Using fluid other than Genuine NISSAN Matic D ATF will cause deterioration in driveability and transfer durability, and may damage the transfer, which is not covered by the NISSAN new vehicle limited warranty.

## FOR USA AND CANADA : Engine Oil Recommendation

INFOID:000000008633148

NISSAN recommends the use of an energy conserving oil in order to improve fuel economy. Select only engine oils that meet the American Petroleum Institute (API) certification and International Lubricant Standardization and Approval Committee (ILSAC) certification and SAE viscosity standard. These oils have the API certification mark on the front of the container. Oils which do not have the specified quality label should not be used as they could cause engine damage.

A  
B  
C  
D  
E  
F  
G  
H  
I  
J  
K  
L  
M  
N  
O  
MA

# RECOMMENDED FLUIDS AND LUBRICANTS

< PERIODIC MAINTENANCE >



1. API certification mark

2. API service symbol

## FOR USA AND CANADA : Engine Coolant Mixture Ratio

INFOID:000000008633149

The engine cooling system is filled at the factory with a pre-diluted mixture of 50% Genuine NISSAN Long Life Antifreeze/Coolant (blue) and 50% water to provide year-round anti-freeze and coolant protection. The anti-freeze solution contains rust and corrosion inhibitors. Additional engine cooling system additives are not necessary.

### WARNING:

- Do not remove the radiator or coolant reservoir cap when the engine is hot. Wait until the engine and radiator cool down. Serious burns could be caused by high pressure fluid escaping from the radiator.
- The radiator is equipped with a pressure type radiator cap. To prevent engine damage, use only a genuine NISSAN radiator cap.

### CAUTION:

- When adding or replacing coolant, be sure to use only Genuine NISSAN Long Life Antifreeze/Coolant (blue) or equivalent. Genuine NISSAN Long Life Antifreeze/Coolant (blue) is pre-diluted to provide antifreeze protection to -34°F (-37°C). If additional freeze protection is needed due to weather where you operate your vehicle, add Genuine NISSAN Long Life Antifreeze/Coolant (blue) concentrate following the directions on the container. If an equivalent coolant other than Genuine NISSAN Long Life Antifreeze/Coolant (blue) is used, follow the coolant manufacturer's instructions to maintain minimum antifreeze protection to -34°F (-37°C). The use of other types of coolant solutions other than Genuine NISSAN Long Life Antifreeze/Coolant (blue) or equivalent may damage the engine cooling system.
- Mixing any other type of coolant other than Genuine NISSAN Long Life Antifreeze/Coolant (blue), including Genuine NISSAN Long Life Antifreeze/Coolant (green), or the use of non-distilled water will reduce the life expectancy of the factory-fill coolant.

## FOR MEXICO

## FOR MEXICO : Fluids and Lubricants

INFOID:000000008633150

Description		Capacity (Approximate)			Recommended Fluids/Lubricants
		Metric	US measure	Imp measure	
Fuel		105.8 ℓ	28 gal	23-1/4 gal	Unleaded gasoline with an octane rating of at least 87 AKI (RON 91)
Engine oil Drain and refill	With oil filter change	6.5 ℓ	6-7/8 qt	5-3/4 qt	<ul style="list-style-type: none"> <li>• Genuine NISSAN engine oil *1</li> <li>• API grade SL, SM or SN *1</li> <li>• ILSAC grade GF-2, GF-3, GF-4 or GF-5 *1</li> <li>• Viscosity SAE 10W-30 *1</li> </ul>
	Without oil filter change	6.2 ℓ	6-1/2 qt	5-1/2 qt	
Dry engine (engine overhaul)		7.6 ℓ	8 qt	6-3/4 qt	
Cooling system	With reservoir at MAX level	14.4 ℓ	15-1/4 qt	12-5/8 qt	Genuine NISSAN Engine Coolant (blue) or equivalent *2
Automatic transmission fluid (ATF)		10.6 ℓ	11-1/4 qt	9-3/8 qt	Genuine NISSAN Matic S ATF *3
Rear differential gear oil		1.75 ℓ	3-3/4 pt	3-1/8 pt	Genuine NISSAN Differential Oil Hypoid Super-S Synthetic 75W-90 or equivalent *4

# RECOMMENDED FLUIDS AND LUBRICANTS

## < PERIODIC MAINTENANCE >

Description	Capacity (Approximate)			Recommended Fluids/Lubricants
	Metric	US measure	Imp measure	
Transfer fluid	3.0 ℓ	3-1/8 qt	2-5/8 qt	Genuine NISSAN Matic D ATF recommended *5
Front differential gear oil	1.6 ℓ	3-3/8 pt	2-7/8 pt	Genuine NISSAN Differential Oil Hypoid Super GL-5 80W-90 or API GL-5 Viscosity SAE 80W-90
Power steering fluid (PSF)	1.0 ℓ	1-1/8 qt	7/8 qt	Genuine NISSAN PSF or equivalent *6
Brake fluid	—	—	—	Genuine NISSAN Brake Fluid or equivalent DOT 3 (US FMVSS No. 116)
Multi-purpose grease	—	—	—	NLGI No. 2 (lithium soap base)
Windshield washer fluid	4.5 ℓ	4-3/4 qt	4 qt	Windshield washer fluid
Air conditioning system refrigerant	1.08 ± 0.05 kg	2.38 ± 0.11 lb	2.38 ± 0.11 lb	HFC-134a (R-134a) *7
Air conditioning system oil	290 m ℓ	9.8 fl oz	10.2 fl oz	A/C System Oil Type S (DH-PS) *7

\*1: For further details, refer to [MA-19. "FOR MEXICO : SAE Viscosity Number"](#).

\*2: Use Genuine NISSAN Engine Coolant (blue) or equivalent in its quality, in order to avoid possible aluminium corrosion within the engine cooling system caused by the use of non-genuine engine coolant.

Note that any repairs for the incidents within the engine cooling system while using non-genuine engine coolant may not be covered by the warranty even if such incidents occurred during the warranty period.

\*3: If Genuine NISSAN Matic S ATF is not available, Genuine NISSAN Matic J ATF may also be used. Using automatic transmission fluid other than Genuine NISSAN Matic S ATF or Matic J ATF will cause deterioration in driveability and automatic transmission durability, and may damage the automatic transmission, which is not covered by the warranty.

\*4: See a NISSAN dealer for service for synthetic oil.

\*5: Using fluid other than Genuine NISSAN Matic D ATF will cause deterioration in driveability and transfer durability, and may damage the transfer, which is not covered by the warranty.

\*6: DEXRON™ VI type ATF may also be used.

\*7: For further details, see "Air conditioner specification label".

## FOR MEXICO : SAE Viscosity Number

INFOID:000000008633151

### GASOLINE ENGINE OIL

- 10W-30 is preferable.
- 5W-30 is also preferable and will improve fuel economy.
- If 10W-30 or 5W-30 is not available, select the viscosity from the chart, that is suitable for the outside temperature range.

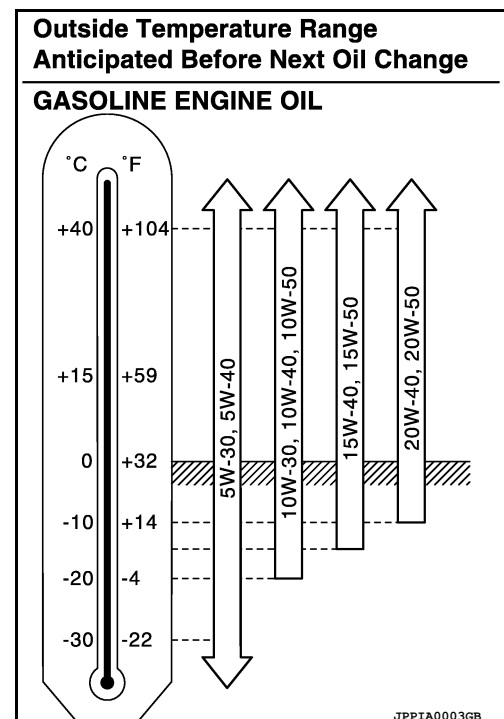

# RECOMMENDED FLUIDS AND LUBRICANTS

## < PERIODIC MAINTENANCE >

### DIFFERENTIAL GEAR OIL

- 80W-90 for the front differential gear is preferable.

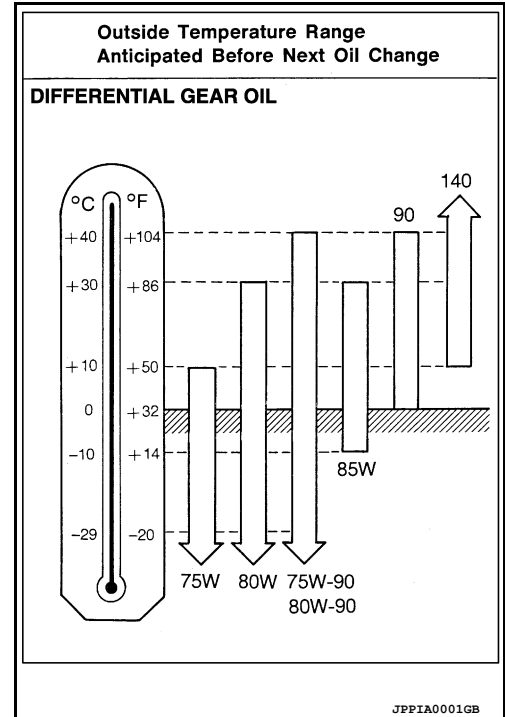

### ANTI-FREEZE COOLANT MIXTURE RATIO

The engine cooling system is filled at the factory with a high-quality, year-round and extended life engine coolant. The high quality engine coolant contains the specific solutions effective for the anti-corrosion and the anti-freeze function. Therefore, additional cooling system additives are not necessary.

Protection for outside temperature down to:		Engine Coolant or equivalent	Demineralized water or distilled water
°C	°F		
-15°	5°	30%	70%
-35°	-30°	50%	50%

### CAUTION:

- When adding or replacing coolant, be sure to use only the specified engine coolant or equivalent in its quality with the proper mixture ratio. See the examples shown in the figure. The use of other types of engine coolant may damage your cooling system.
- When checking the engine coolant mixture ratio by the coolant hydrometer, use the chart below to correct your hydrometer reading (specific gravity) according to coolant temperature.

#### Mixed Coolant Specific Gravity

Engine coolant mixture ratio	Coolant temperature °C (°F)			
	15° (59°)	25° (77°)	35° (95°)	45° (113°)
	Specific gravity			
30%	1.046 - 1.050	1.042 - 1.046	1.038 - 1.042	1.033 - 1.038
50%	1.076 - 1.080	1.070 - 1.076	1.065 - 1.071	1.059 - 1.065

### WARNING:

Do not remove the radiator cap when the engine is hot. Serious burns could be caused by high pressure fluid escaping from the radiator. Wait until the engine and radiator cool down.

# ENGINE MAINTENANCE

< PERIODIC MAINTENANCE >

## ENGINE MAINTENANCE

### DRIVE BELTS

#### DRIVE BELTS : Checking Drive Belts

INFOID:000000008633152

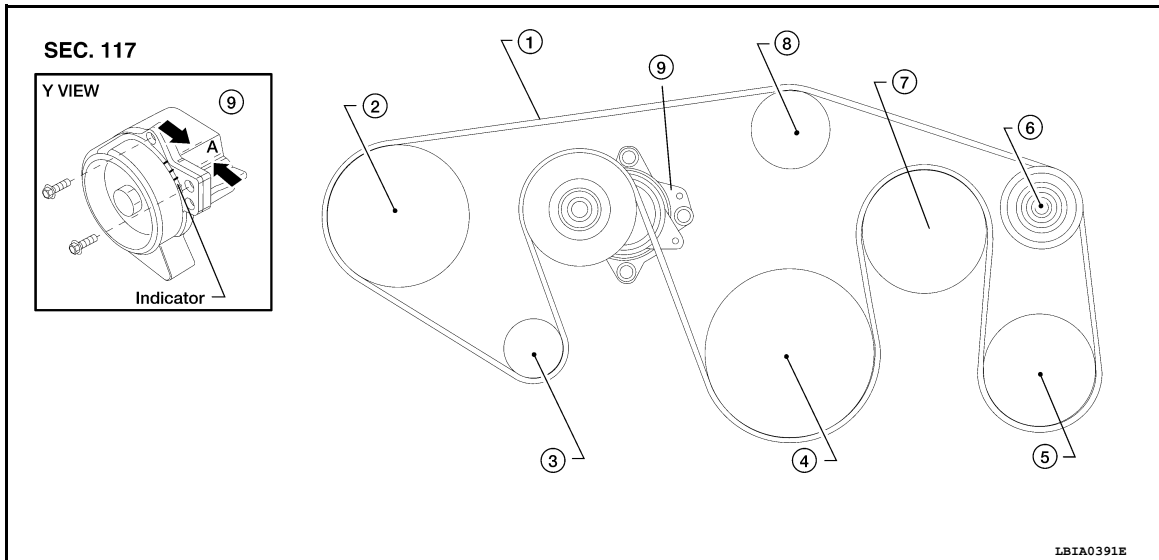

- |                            |                               |                              |
|----------------------------|-------------------------------|------------------------------|
| 1. Drive belt              | 2. Power steering pump pulley | 3. Generator pulley          |
| 4. Crankshaft pulley       | 5. A/C compressor             | 6. Idler pulley              |
| 7. Cooling fan pulley      | 8. Water pump pulley          | 9. Drive belt auto-tensioner |
| A. Allowable working range |                               |                              |

#### **WARNING:**

**Be sure to perform when the engine is stopped.**

1. Remove air duct and resonator assembly when inspecting drive belt.
2. Make sure that indicator (single line notch) of each auto-tensioner is within the allowable working range (between three line notches).

#### **NOTE:**

- Check the drive belt auto-tensioner indication when the engine is cold.
  - The indicator notch is located on the moving side of the drive belt auto-tensioner.
3. Visually check entire drive belt for wear, damage or cracks.
  4. If the indicator is out of allowable working range or drive belt is damaged, replace the drive belt. Refer to [MA-21](#).

#### DRIVE BELT TENSION

There is no manual drive belt tension adjustment. The drive belt tension is automatically adjusted by the drive belt auto-tensioner.

#### ENGINE COOLANT

#### ENGINE COOLANT : Inspection

INFOID:000000008633153

#### LEVEL CHECK

MA

# ENGINE MAINTENANCE

## < PERIODIC MAINTENANCE >

- Check if the engine coolant reservoir tank level is within MIN to MAX level when engine is cool.
- Adjust engine coolant level as necessary.

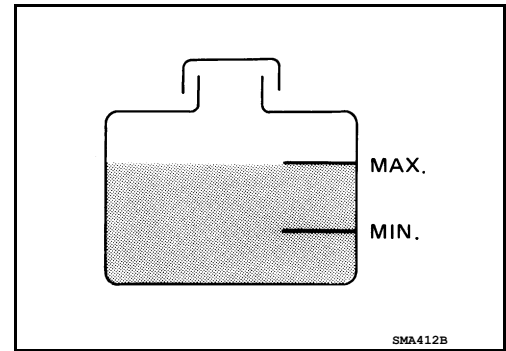

## ENGINE COOLANT : Changing Engine Coolant

INFOID:000000008633154

### WARNING:

- To avoid being scalded, never change the coolant when the engine is hot.
- Wrap a thick cloth around the cap to carefully remove the cap. First, turn the cap a quarter of a turn to release any built-up pressure, then push down and turn the cap all the way to remove it.

### DRAINING ENGINE COOLANT

1. Turn ignition switch ON and set temperature control lever all the way to HOT position or the highest temperature position. Wait 10 seconds and turn ignition switch OFF.
2. Remove the engine front under cover using power tool. Refer to [EXT-15. "Removal and Installation"](#).
3. Open the radiator drain plug at the bottom of the radiator, and remove the radiator filler cap. This is the only step required when partially draining the cooling system (radiator only).

### CAUTION:

- Perform this step when the engine is cold.
- Do not to allow the coolant to contact the drive belts.

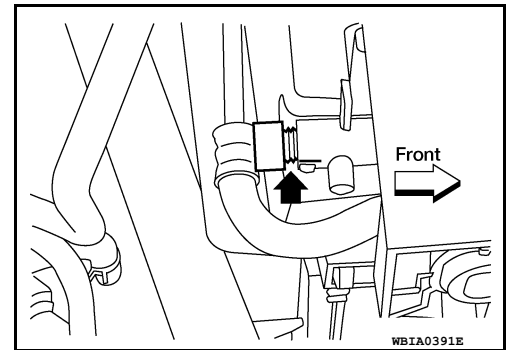

4. When draining all of the coolant in the system for engine removal or repair, it is necessary to drain the cylinder block. Remove the RH cylinder block drain plug to drain the right bank and the oil cooler hose to drain the left bank as shown.

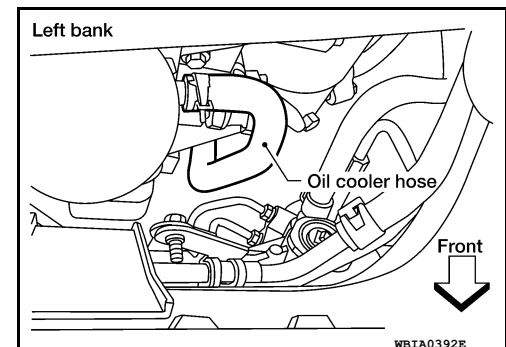
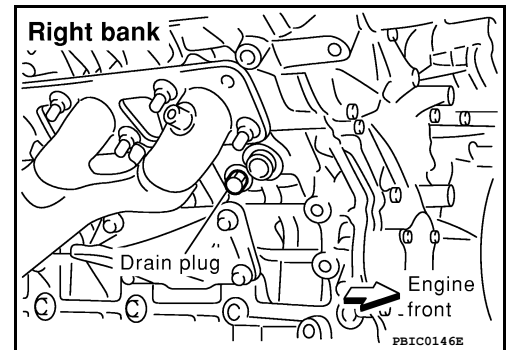

# ENGINE MAINTENANCE

## < PERIODIC MAINTENANCE >

- Remove the reservoir tank to drain the engine coolant, then clean the reservoir tank before installing it.
- Check the drained coolant for contaminants such as rust, corrosion or discoloration.  
If the coolant is contaminated, flush the engine cooling system. Refer to [MA-22. "ENGINE COOLANT : Changing Engine Coolant"](#).

## REFILLING ENGINE COOLANT

- Close the radiator drain plug. Install the reservoir tank, cylinder block drain plug, and the oil cooler hose, if removed for a total system drain or for engine removal or repair.
  - The radiator must be completely empty of coolant and water.
  - Apply sealant to the threads of the cylinder block drain plug. Use Genuine High Performance Thread Sealant or equivalent. Refer to [GI-17. "Recommended Chemical Products and Sealants"](#).

**Radiator drain plug** : Refer to [CO-16](#).

**RH cylinder block drain plug** : Refer to [EM-93](#).

- Set the vehicle heater controls to the full HOT and heater ON position. Turn the vehicle ignition ON with the engine OFF as necessary to activate the heater mode.
- Remove the vented reservoir cap and replace it with a non-vented reservoir cap before filling the cooling system.
- Install the Tool by installing the radiator cap adapter onto the radiator neck opening. Then attach the gauge body assembly with the refill tube and the venturi assembly to the radiator cap adapter.

**Tool number** : **KV991J0070 (J-45695)**

- Insert the refill hose into the coolant mixture container that is placed at floor level. Make sure the ball valve is in the closed position.
  - Use specified coolant or equivalent.  
Refer to [CO-26. "Standard and Limit"](#).

**Cooling system capacity (with reservoir)** : Refer to [CO-26. "Standard and Limit"](#).

- Install an air hose to the venturi assembly, the air pressure must be within specification.

**Compressed air supply pressure** : **549 - 824 kPa (5.6 - 8.4 kg/cm<sup>2</sup>, 80 - 119 psi)**

### CAUTION:

The compressed air supply must be equipped with an air dryer.

- The vacuum gauge will begin to rise and there will be an audible hissing noise. During this process open the ball valve on the refill hose slightly. Coolant will be visible rising in the refill hose. Once the refill hose is full of coolant, close the ball valve. This will purge any air trapped in the refill hose.
- Continue to draw the vacuum until the gauge reaches 28 inches of vacuum. The gauge may not reach 28 inches in high altitude locations, refer to the vacuum specifications based on the altitude above sea level.

Altitude above sea level	Vacuum gauge reading
0 - 100 m (328 ft)	: 28 inches of vacuum
300 m (984 ft)	: 27 inches of vacuum
500 m (1,641 ft)	: 26 inches of vacuum
1,000 m (3,281 ft)	: 24 - 25 inches of vacuum

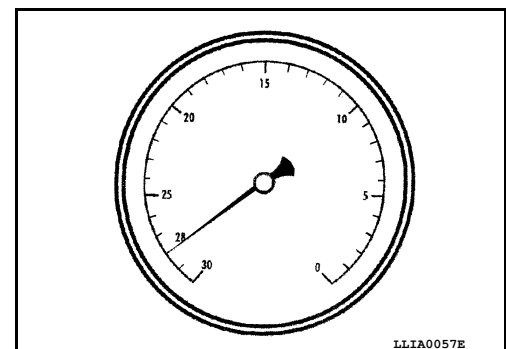
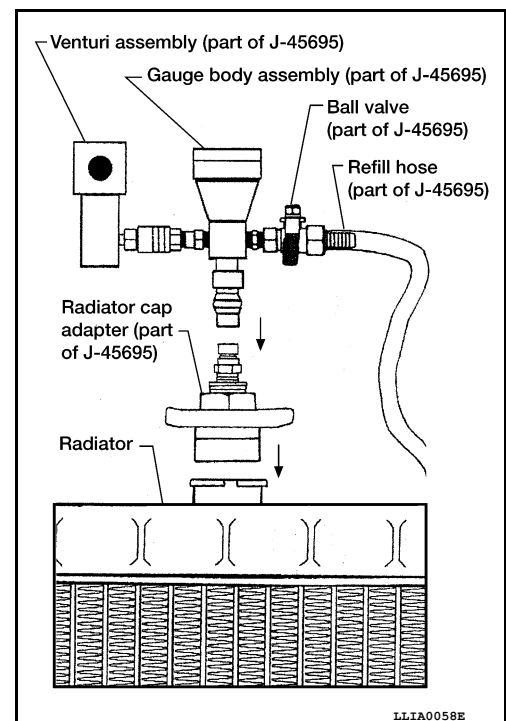

# ENGINE MAINTENANCE

## < PERIODIC MAINTENANCE >

9. When the vacuum gauge has reached the specified amount, disconnect the air hose and wait 20 seconds to see if the system loses any vacuum. If the vacuum level drops, perform any necessary repairs to the system and repeat steps 6 - 8 to bring the vacuum to the specified amount. Recheck for any leaks.
10. Place the coolant container (with the refill hose inserted) at the same level as the top of the radiator. Then open the ball valve on the refill hose so the coolant will be drawn up to fill the cooling system. The cooling system is full when the vacuum gauge reads zero.  
**CAUTION:**  
**Do not allow the coolant container to get too low when filling, to avoid air from being drawn into the cooling system.**
11. Remove the Tool from the radiator neck opening and install the radiator cap.
12. Remove the non-vented reservoir cap.
13. Fill the cooling system reservoir tank to the specified level. Run the engine to warm up the cooling system and top up the system as necessary before installing the vented reservoir cap.
14. Install the engine front under cover. Refer to [EXT-15, "Removal and Installation"](#).

## FLUSHING COOLING SYSTEM

1. Drain the water from the engine cooling system. Refer to [MA-22, "ENGINE COOLANT : Changing Engine Coolant"](#).
2. Fill the radiator and the reservoir tank (to the "MAX" line), with water. Reinstall the radiator cap and leave the vented reservoir cap off.
3. Run the engine until it reaches normal operating temperature.
4. Press the engine accelerator two or three times under no-load.
5. Stop the engine and wait until it cools down.
6. Drain the water from the engine cooling system. Refer to [MA-22, "ENGINE COOLANT : Changing Engine Coolant"](#).
7. Repeat steps 2 through 6 until clear water begins to drain from the radiator.

## FUEL LINES

### FUEL LINES : Checking Fuel Line

INFOID:000000008633155

Inspect fuel lines, fuel filler cap and fuel tank for improper attachment, leaks, cracks, damage, loose connections, chafing or deterioration.

If necessary, repair or replace damaged parts.

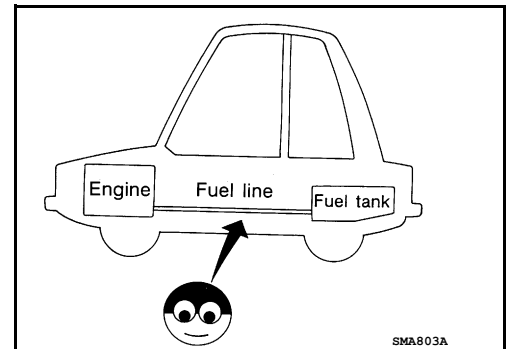

## FUEL FILTER

### FUEL FILTER : Removal and Installation

INFOID:000000008633156

The fuel filter is part of the fuel level sensor, fuel filter and fuel pump assembly and is not serviced separately. Refer to [FL-12, "Removal and Installation"](#)

## AIR CLEANER FILTER

### AIR CLEANER FILTER : Removal and Installation (Viscous paper type)

INFOID:000000008633157

## REMOVAL



# ENGINE MAINTENANCE

## < PERIODIC MAINTENANCE >

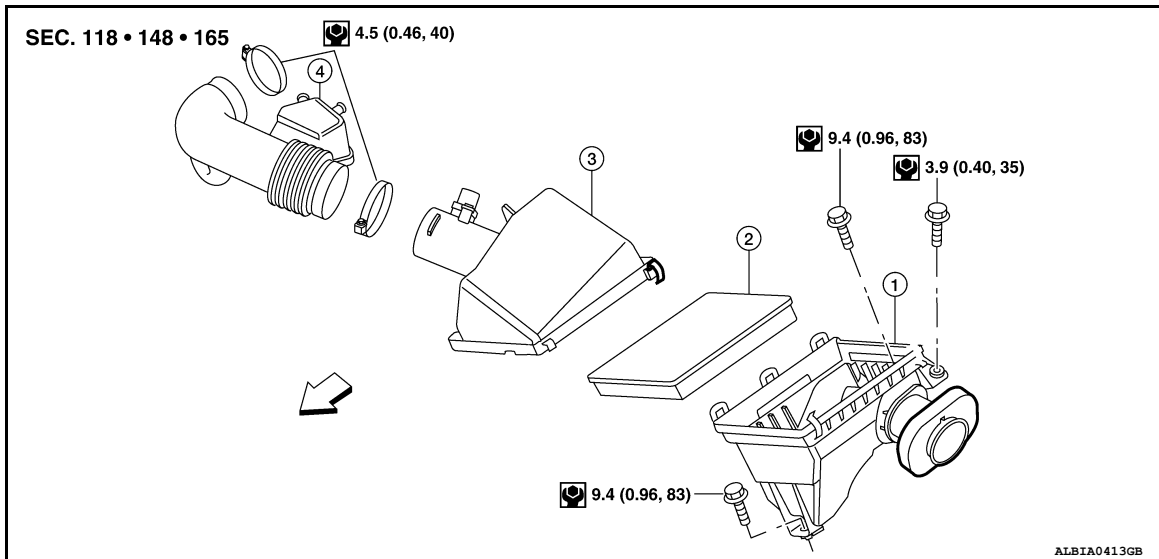

1. Air cleaner case (lower)      2. Air cleaner filter      3. Air cleaner case (upper)  
4. Air duct and resonator assembly      ← Front

### NOTE:

- The viscous paper type filter does not need cleaning between replacement intervals.
- Replace the air filter as necessary for periodic maintenance. Refer to [MA-10, "FOR USA AND CANADA : Introduction of Periodic Maintenance"](#) (United States and Canada), [MA-14, "FOR MEXICO : Introduction of Periodic Maintenance"](#) (Mexico).

1. Remove the air cleaner case (upper).
2. Remove the air cleaner filter from the air cleaner case (lower).

### INSTALLATION

1. Install the new air cleaner filter in the air cleaner case (lower).
2. Install the air cleaner case (upper).

## ENGINE OIL

### ENGINE OIL : Inspection

INFOID:000000008633158

### OIL LEVEL

- Before starting the engine make sure the vehicle is parked on a flat and level surface, then check the oil level. If the engine is already running, turn it off and allow 10 minutes before checking.
- Check that the oil level is within the low (L) to high (H) range as indicated on the dipstick.
- If the engine oil level is out of range, add oil as necessary. Refer to [MA-17, "FOR USA AND CANADA : Fluids and Lubricants"](#).

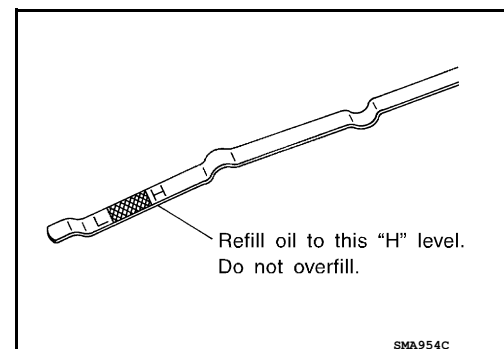

### ENGINE OIL : Changing Engine Oil

INFOID:000000008633159

### WARNING:

# ENGINE MAINTENANCE

## < PERIODIC MAINTENANCE >

- Be careful not to burn yourself, as the engine oil is hot.
  - Prolonged and repeated contact with used engine oil may cause skin cancer. Try to avoid direct skin contact with used engine oil. If skin contact is made, wash thoroughly with soap or hand cleaner as soon as possible.
1. Remove engine under cover using power tool. Refer to [EXT-15, "Removal and Installation"](#).
  2. Warm up engine, and check for oil leakage from engine components. Refer to [MA-25, "ENGINE OIL : Inspection"](#).
  3. Stop engine and wait for 10 minutes.
  4. Loosen oil filler cap, then remove drain plug.
  5. Drain engine oil.
  6. Install drain plug with new washer.  
**CAUTION:**
    - Be sure to clean drain plug and install with new washer.

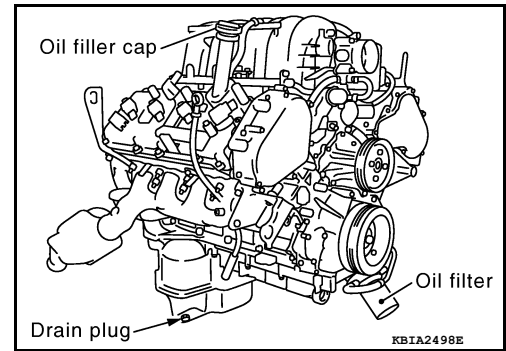

**Oil pan drain plug : 34.3 N·m (3.5 kg·m, 25 ft·lb)**

7. Refill with new engine oil. Refer to [MA-17, "FOR USA AND CANADA : Fluids and Lubricants"](#) (United States and Canada), [MA-18, "FOR MEXICO : Fluids and Lubricants"](#) (Mexico).  
**CAUTION:**
  - The refill capacity depends on the engine oil temperature and drain time. Use these specifications for reference only.
  - Always use the oil level gauge to determine when the proper amount of engine oil is in the engine.
8. Warm up engine and check area around drain plug and oil filter for oil leakage.
9. Install engine under cover. Refer to [EXT-15, "Removal and Installation"](#).
10. Stop engine and wait for 10 minutes.
11. Check engine oil level. Refer to [MA-25, "ENGINE OIL : Inspection"](#).

## OIL FILTER

### OIL FILTER : Removal and Installation

INFOID:000000008633160

#### REMOVAL

1. Remove the engine under cover using power tool. Refer to [EXT-15, "Removal and Installation"](#).
2. Drain the engine oil. Refer to [MA-25, "ENGINE OIL : Changing Engine Oil"](#).
3. Remove the oil filter using Tool.

**Tool number : KV10115801 (J-38956)**

#### **WARNING:**

- Be careful not to get burned when the engine and engine oil are hot.

#### **CAUTION:**

- The oil filter is provided with a relief valve.
- Use Genuine NISSAN oil filter or equivalent.
- When removing, prepare a shop cloth to absorb any engine oil leakage or spillage.
- Do not allow engine oil to adhere to the drive belt.
- Completely wipe off any engine oil that adheres to the engine and the vehicle.

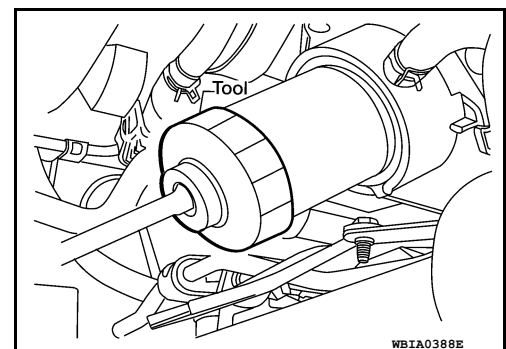

#### INSTALLATION

1. Remove foreign materials adhering to the oil filter installation surface.

# ENGINE MAINTENANCE

## < PERIODIC MAINTENANCE >

2. Apply engine oil to the oil seal circumference of the new oil filter.

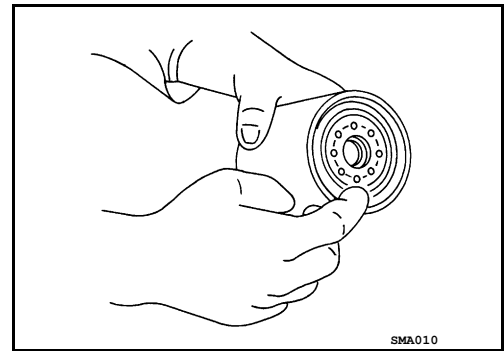

3. Screw the oil filter manually until it touches the installation surface, then tighten it by 2/3 turn. Or tighten to specification.

**Oil filter : 17.7 N·m (1.8 kg-m, 13 ft-lb)**

4. Refill the engine with new engine oil. Refer to [MA-25, "ENGINE OIL : Changing Engine Oil"](#).
5. Inspect the engine for oil leakage. Follow the "INSPECTION AFTER INSTALLATION" procedure.
6. Install the engine under cover. Refer to [EXT-15, "Removal and Installation"](#).

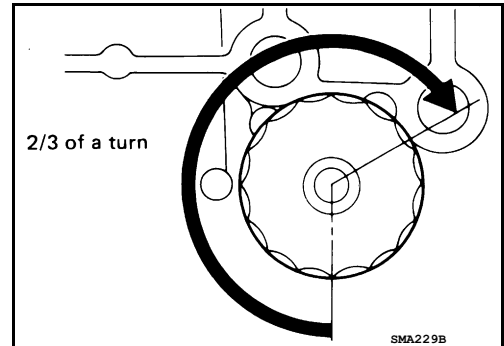

## INSPECTION AFTER INSTALLATION

1. Check the engine oil level. Refer to [MA-25, "ENGINE OIL : Inspection"](#).
2. Start the engine and check for engine oil leakage.
3. Stop the engine and wait for 10 minutes.
4. Check the engine oil level and add engine oil as required.

## SPARK PLUG

### SPARK PLUG : Removal and Installation

INFOID:000000008633161

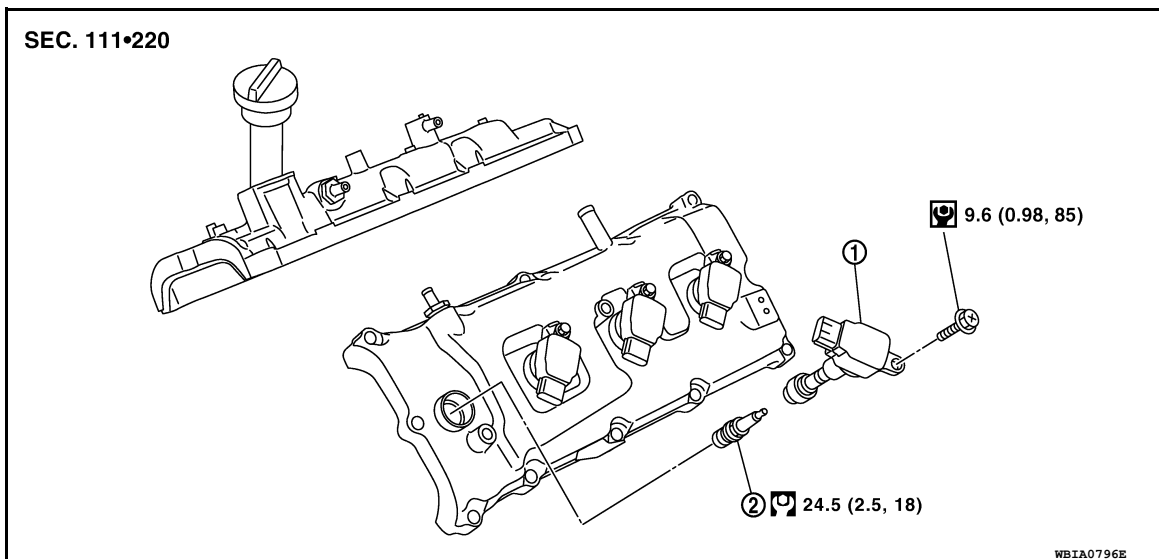

1. Ignition coil

2. Spark plug

## REMOVAL

1. Remove the ignition coil. Refer to [EM-40, "Removal and Installation"](#).

**CAUTION:**

**Do not shock ignition coil.**

A  
B  
C  
D  
E  
F  
G  
H  
I  
J  
K  
L  
M  
N  
O  
MA

# ENGINE MAINTENANCE

## < PERIODIC MAINTENANCE >

2. Remove spark plug using suitable tool.

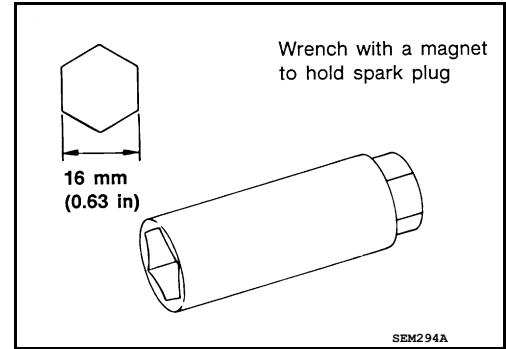

### INSPECTION AFTER REMOVAL

- Do not use a wire brush for cleaning.
- If plug tip is covered with carbon, spark plug cleaner may be used.

**Cleaner air pressure** : Less than 588 kPa (6 kg/cm<sup>2</sup>, 85 psi)

**Cleaning time** : Less than 20 seconds

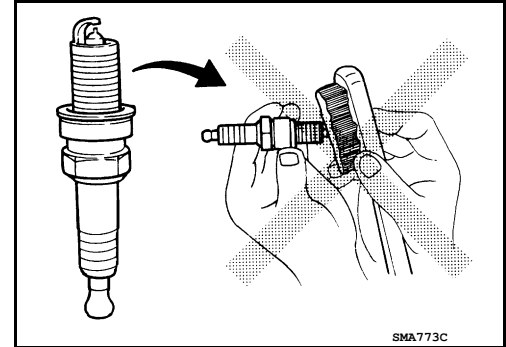

- Checking and adjusting plug gap is not required between change intervals.

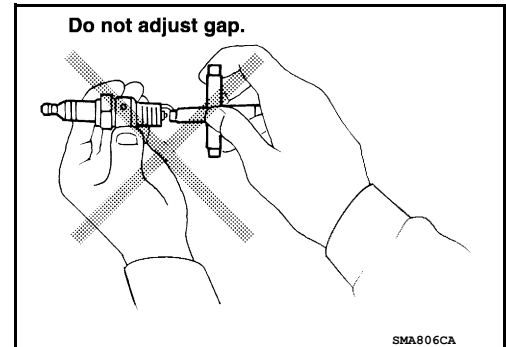

### INSTALLATION

Installation is in the reverse order of removal.

#### Spark Plug Types

Make	NGK	
	Standard model	FFV model
Model	DILFR5A-11	DILFR5A-11D
Standard type*	DILFR5A-11	DILFR5A-11D
Gap (Nominal)	1.1 mm (0.043 in)	1.1 mm (0.043 in)

\*: Always check with the Parts Department for the latest parts information.

#### **CAUTION:**

**Do not drop or shock spark plug.**

#### EVAP VAPOR LINES

#### EVAP VAPOR LINES : Checking EVAP Vapor Line

INFOID:000000008633162

1. Visually inspect the EVAP vapor lines for improper attachment, cracks, damage, loose connections, chafing, or deterioration.
2. Inspect the vacuum relief valve of the fuel tank filler cap for clogging and sticking. Refer to [EC-491, "How to Detect Fuel Vapor Leakage"](#).

# CHASSIS AND BODY MAINTENANCE

< PERIODIC MAINTENANCE >

## CHASSIS AND BODY MAINTENANCE

### IN-CABIN MICROFILTER

#### IN-CABIN MICROFILTER : Removal and Installation

INFOID:000000008633163

#### REPLACEMENT PROCEDURE

1. Remove the glove box assembly from the instrument panel. Refer to [IP-17. "Removal and Installation"](#).
2. Remove the screw and remove the in-cabin microfilter cover (A) as shown.
3. Remove the two in-cabin microfilters from the front heater and cooling unit assembly housing.

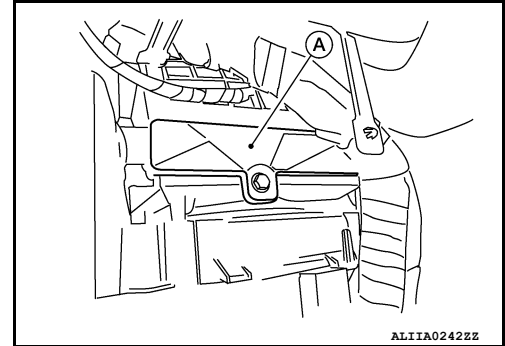

4. Insert the first new in-cabin microfilter into the front heater and cooling unit assembly housing and slide it over to the right. Insert the second new in-cabin microfilter into the front heater and cooling unit assembly housing as shown.

**NOTE:**

The in-cabin microfilters are marked with air flow arrows. The end of the microfilter with the arrow should face the rear of the vehicle. The arrows should point downward.

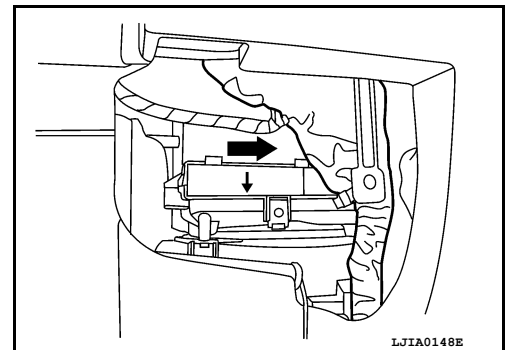

5. Install the in-cabin microfilter cover (A).

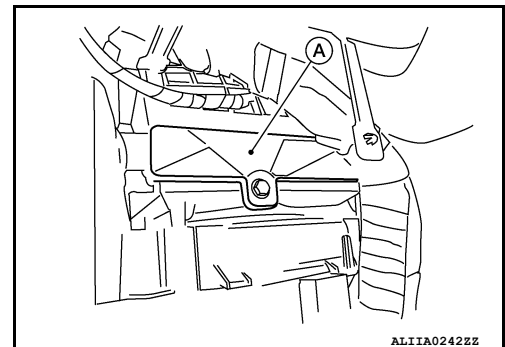

6. Install the glove box assembly in the instrument panel. Refer to [IP-17. "Removal and Installation"](#).
7. Fill out the date information on the small replacement label and attach it to the glove box lid.

### EXHAUST SYSTEM

#### EXHAUST SYSTEM : Checking Exhaust System

INFOID:000000008633164

Check exhaust pipes, muffler and mounting for improper attachment, leaks, cracks, damage or deterioration.

# CHASSIS AND BODY MAINTENANCE

## < PERIODIC MAINTENANCE >

- If anything is found, repair or replace damaged parts.

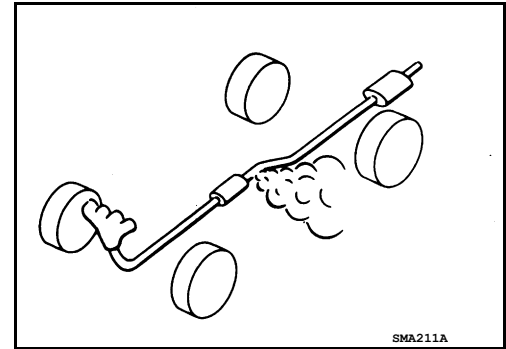

## A/T FLUID

### A/T FLUID : Checking the A/T Fluid (ATF)

INFOID:000000008633165

#### CAUTION:

If using the vehicle for towing, the A/T fluid must be replaced as specified. Refer to [MA-10, "FOR USA AND CANADA : Introduction of Periodic Maintenance"](#) (United States and Canada), [MA-14, "FOR MEXICO : Introduction of Periodic Maintenance"](#) (Mexico).

1. Before driving, the A/T fluid level can be checked at A/T fluid temperatures of 30° to 50° C (86° to 122° F) using the "COLD" range on the A/T fluid level gauge as follows:
  - a. Park the vehicle on a level surface and set the parking brake.
  - b. Start the engine and move the shift selector through each gear position. Move the shift selector into the "P" position.
  - c. Check the A/T fluid level with the engine idling.
  - d. Remove the A/T fluid level gauge and wipe it clean with a lint-free paper.

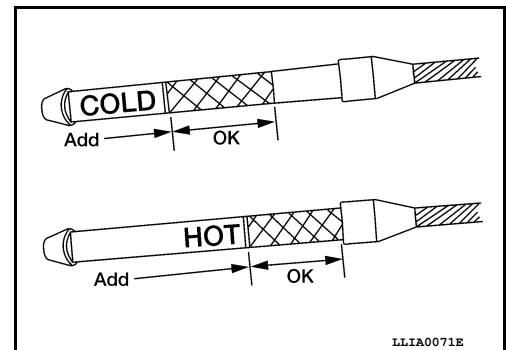

#### CAUTION:

When wiping the A/T fluid from the A/T fluid level gauge, always use a lint-free paper, not a cloth.

- e. Re-insert the A/T fluid level gauge into the A/T fluid charging pipe until the cap contacts the top of the A/T fluid charging pipe as shown.

#### CAUTION:

To check A/T fluid level, insert the A/T fluid level gauge until the cap contacts the top of the A/T fluid charging pipe, with the gauge reversed from the normal inserted position.

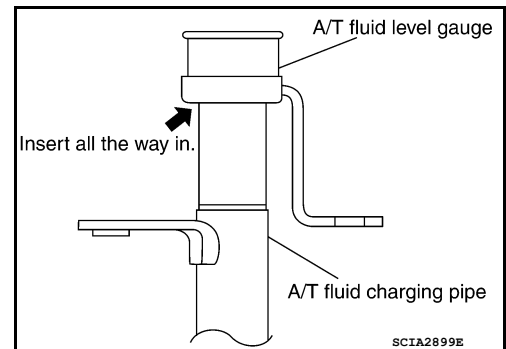

- f. Remove the A/T fluid level gauge and note the A/T fluid level. If the A/T fluid level is at low side of range, add A/T fluid to the transmission through the A/T fluid charging pipe.

**A/T fluid grade and capacity** : Refer to [MA-17, "FOR USA AND CANADA : Fluids and Lubricants"](#) (United States and Canada), [MA-18, "FOR MEXICO : Fluids and Lubricants"](#) (Mexico).

#### CAUTION:

Do not overfill the transmission with A/T fluid.

- g. Install the A/T fluid level gauge and the A/T fluid level gauge bolt.

**A/T fluid level gauge bolt** : Refer to [TM-193, "Removal and Installation \(2WD\)"](#) (2WD) or [TM-195, "Removal and Installation \(4WD\)"](#) (4WD).

2. Warm up the engine and transmission.

# CHASSIS AND BODY MAINTENANCE

## < PERIODIC MAINTENANCE >

3. Check for any A/T fluid leaks.
4. Drive the vehicle to increase the A/T fluid temperature to 80° C (176° F).
5. Allow the A/T fluid temperature to fall to approximately 65°C (149°F). Use the CONSULT to monitor the A/T fluid temperature as follows:

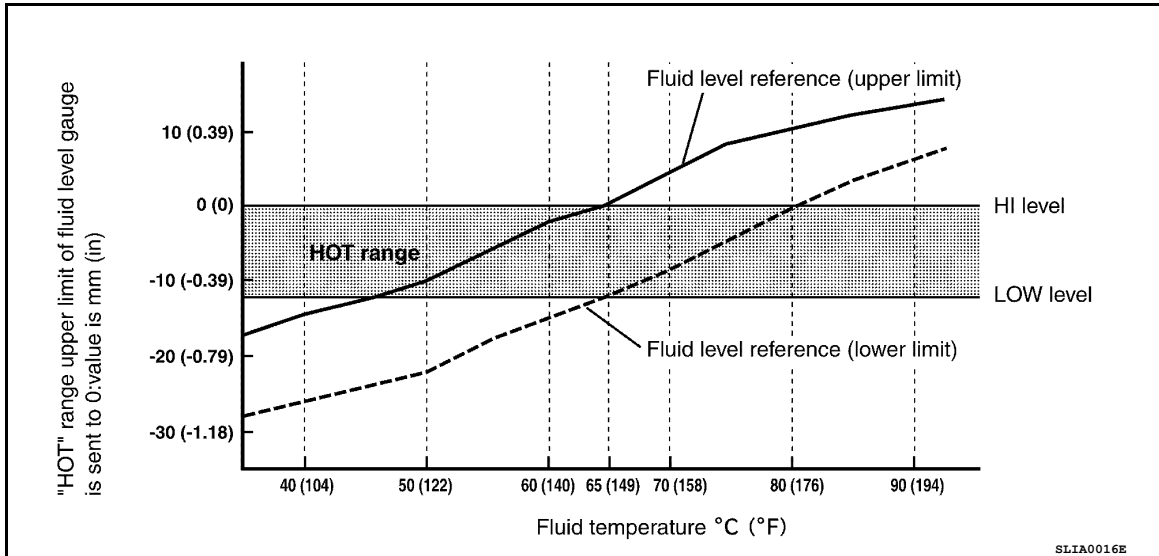

### NOTE:

The A/T fluid level will be significantly affected by the A/T fluid temperature as shown. Therefore monitor the A/T fluid temperature data using the CONSULT.

- a. Connect CONSULT to data link connector.
  - b. Select "MAIN SIGNALS" in "DATA MONITOR" mode for "A/T" with CONSULT.
  - c. Read out the value of "ATF TEMP 1".
6. Re-check the A/T fluid level at A/T fluid temperatures of approximately 65°C (149°F) using the "HOT" range on the A/T fluid level gauge as shown. The HOT range is between 50° - 80° C (122° - 176° F).

### CAUTION:

- When wiping the A/T fluid from the A/T fluid level gauge, always use lint-free paper, not a cloth.

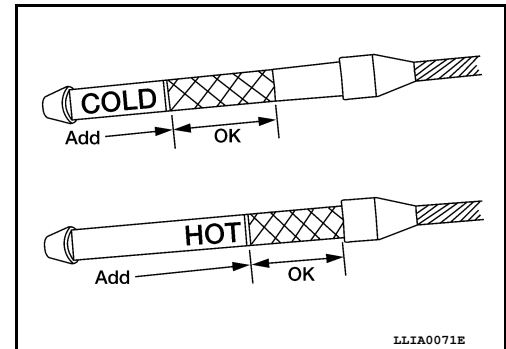

- To check the A/T fluid level, insert the A/T fluid level gauge until the cap contacts the top of the A/T fluid charging pipe, with the gauge reversed from the normal inserted position as shown.

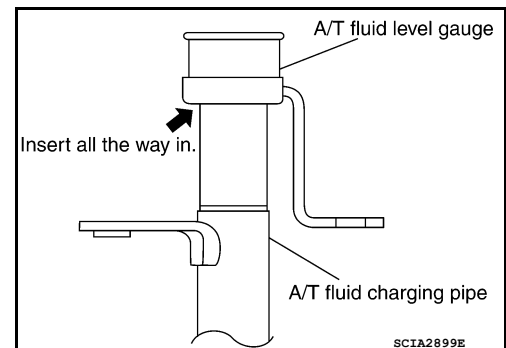

7. Check the A/T fluid condition.
  - If the A/T fluid is very dark or has some burned smell, there may be an internal problem with the transmission. Refer to [TM-162, "A/T Fluid Cooler Cleaning"](#). Flush the transmission cooling system after repairing the transmission.
  - If the A/T fluid contains frictional material (clutches, bands, etc.), replace the radiator and flush the transmission cooler lines using cleaning solvent and compressed air after repairing the transmission.

## CHASSIS AND BODY MAINTENANCE

### < PERIODIC MAINTENANCE >

8. Install the A/T fluid level gauge in the A/T fluid charging pipe.
9. Tighten the A/T fluid level gauge bolt to specification.

**A/T fluid level gauge bolt** : Refer to [TM-193, "Removal and Installation \(2WD\)" \(2WD\)](#) or [TM-195, "Removal and Installation \(4WD\)" \(4WD\)](#).

### A/T FLUID : Changing the A/T Fluid (ATF)

INFOID:000000008633166

#### CAUTION:

If using the vehicle for towing, the A/T fluid must be replaced as specified. Refer to [MA-10, "FOR USA AND CANADA : Introduction of Periodic Maintenance"](#) (United States and Canada), [MA-14, "FOR MEXICO : Introduction of Periodic Maintenance"](#) (Mexico).

1. Drive the vehicle to warm up the A/T fluid to approximately 80° C (176° F).
2. Stop the engine.
3. Remove the A/T fluid level gauge.
4. Drain the A/T fluid from the drain plug hole, then install the drain plug with a new gasket. Refill the transmission with new A/T fluid. Always refill with the same volume as the drained A/T fluid. Use the A/T fluid level gauge to check the A/T fluid level as shown. Add A/T fluid as necessary.

**Drain plug** : Refer to [TM-199, "Component"](#).

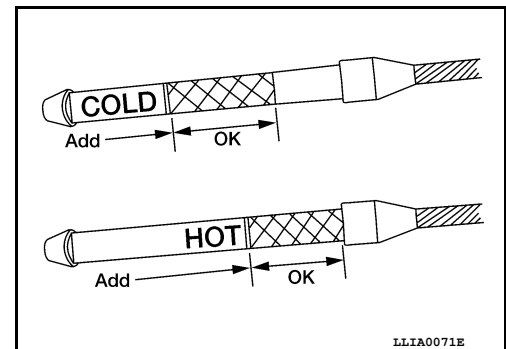

- To flush out the old A/T fluid from the transmission oil coolers, pour new A/T fluid into the A/T fluid charging pipe with the engine idling and at the same time drain the old A/T fluid from the auxiliary transmission oil cooler hose return line.
- When the color of the A/T fluid coming out of the auxiliary transmission oil cooler hose return line is about the same as the color of the new A/T fluid, flushing out the old A/T fluid is complete. The amount of new A/T fluid used for flushing should be 30% to 50% increase of the specified capacity.

**A/T fluid grade and capacity** : Refer to [MA-17, "FOR USA AND CANADA : Fluids and Lubricants"](#) (United States and Canada), [MA-18, "FOR MEXICO : Fluids and Lubricants"](#) (Mexico).

#### CAUTION:

- If Genuine NISSAN Matic S ATF is not available, Genuine NISSAN Matic J ATF may also be used.
  - Using ATF fluid other than Genuine NISSAN Matic S ATF or Matic J ATF will cause deterioration in driveability and A/T durability, and may damage the A/T, which is not covered by the warranty.
  - When filling the transmission with A/T fluid, do not spill the A/T fluid on any heat generating parts such as the exhaust parts.
  - Do not reuse the drain plug gasket.
5. Install the A/T fluid level gauge and tighten the A/T fluid level gauge bolt to specification.

**A/T fluid level gauge bolt** : Refer to [TM-193, "Removal and Installation \(2WD\)" \(2WD\)](#) or [TM-195, "Removal and Installation \(4WD\)" \(4WD\)](#).

6. Drive the vehicle to warm up the A/T fluid to approximately 80° C (176° F).



# CHASSIS AND BODY MAINTENANCE

## < PERIODIC MAINTENANCE >

7. Check the fluid level and condition. If the A/T fluid is still dirty, repeat steps 2 through 6.

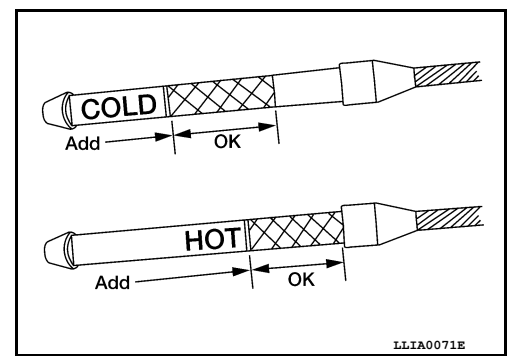

8. Install the A/T fluid level gauge in the A/T fluid charging pipe and install the A/T fluid level gauge bolt.
9. Tighten the A/T fluid level gauge bolt to specification.

**A/T fluid level gauge bolt** : Refer to [TM-193, "Removal and Installation \(2WD\)"](#) (2WD) or [TM-195, "Removal and Installation \(4WD\)"](#) (4WD).

## TRANSFER FLUID

### TRANSFER FLUID : Replacement

INFOID:000000008633167

#### **CAUTION:**

If using the vehicle for towing, the A/T fluid must be replaced as specified. Refer to [MA-10, "FOR USA AND CANADA : Introduction of Periodic Maintenance"](#) (United States and Canada), [MA-14, "FOR MEXICO : Introduction of Periodic Maintenance"](#) (Mexico).

#### DRAINING

1. Stop engine.
2. Remove the drain plug and gasket and drain the fluid.
3. Install the drain plug with a new gasket to the transfer. Tighten to the specified torque. Refer to [DLN-142, "Disassembly and Assembly"](#).

#### **CAUTION:**

**Do not reuse gasket.**

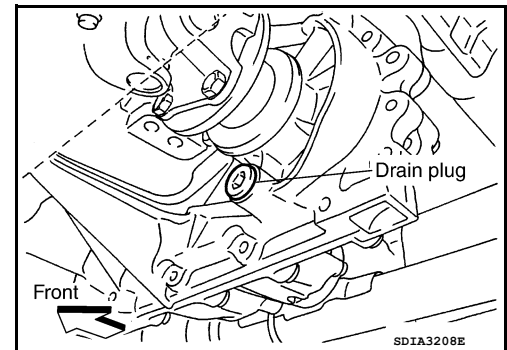

#### FILLING

1. Remove the filler plug and gasket.
2. Fill the transfer with new fluid until the fluid level reaches the specified limit near the filler plug hole.

**Fluid grade and capacity** : Refer to [MA-17, "FOR USA AND CANADA : Fluids and Lubricants"](#) (United States and Canada), [MA-18, "FOR MEXICO : Fluids and Lubricants"](#) (Mexico).

#### **CAUTION:**

**Carefully fill fluid. (Fill up for approx. 3 minutes.)**

3. Leave the vehicle for 3 minutes, and check fluid level again.
4. Install the filler plug with a new gasket to the transfer. Tighten to the specified torque. Refer to [DLN-142, "Disassembly and Assembly"](#).

#### **CAUTION:**

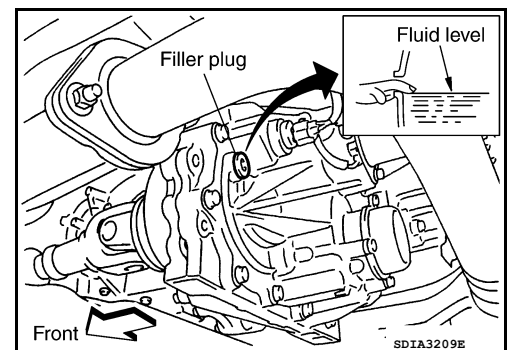

# CHASSIS AND BODY MAINTENANCE

< PERIODIC MAINTENANCE >

Do not reuse gasket.

TRANSFER FLUID : Inspection

INFOID:000000008633169

## CAUTION:

If using the vehicle for towing, the A/T fluid must be replaced as specified. Refer to [MA-10, "FOR USA AND CANADA : Introduction of Periodic Maintenance"](#) (United States and Canada), [MA-14, "FOR MEXICO : Introduction of Periodic Maintenance"](#) (Mexico).

FLUID LEAKAGE AND FLUID LEVEL

1. Make sure that fluid is not leaking from the transfer assembly or around it.
2. Check fluid level from the filler plug hole as shown.

## CAUTION:

Do not start engine while checking fluid level.

3. Install the filler plug with a new gasket to the transfer. Tighten to the specified torque. Refer to [DLN-142, "Disassembly and Assembly"](#).

## CAUTION:

Do not reuse gasket.

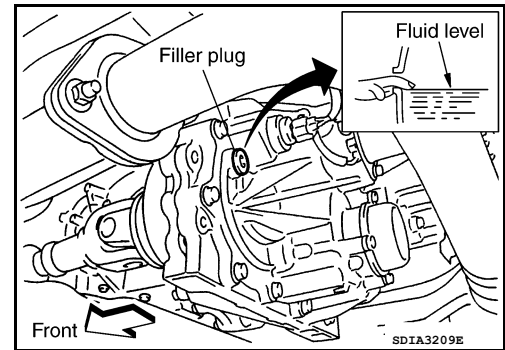

## PROPELLER SHAFT

PROPELLER SHAFT : Checking Propeller Shaft

INFOID:000000008633169

Check the front and rear propeller shafts for damage, dents, and cracks. Check the joints for looseness and any damage. Repair or replace as necessary.

## FRONT DIFFERENTIAL GEAR OIL

FRONT DIFFERENTIAL GEAR OIL : Changing Differential Gear Oil

INFOID:000000008633170

## DRAINING

1. Stop the engine.
2. Remove the drain plug from the front final drive assembly to drain the differential gear oil.
3. Install the drain plug with sealant applied on the threads to the front final drive assembly. Tighten to the specified torque. Refer to [DLN-215, "Disassembly and Assembly"](#).
  - Use High Performance Thread Sealant or equivalent. Refer to [GI-17, "Recommended Chemical Products and Sealants"](#).

## FILLING

1. Remove the filler plug from the front final drive assembly.
2. Fill the front final drive assembly with new differential gear oil until the level reaches the specified level near the filler plug hole.

Differential gear oil  
grade and capacity

: Refer to [MA-17, "FOR USA AND CANADA : Fluids and Lubricants"](#) (United States and Canada), [MA-18, "FOR MEXICO : Fluids and Lubricants"](#) (Mexico).

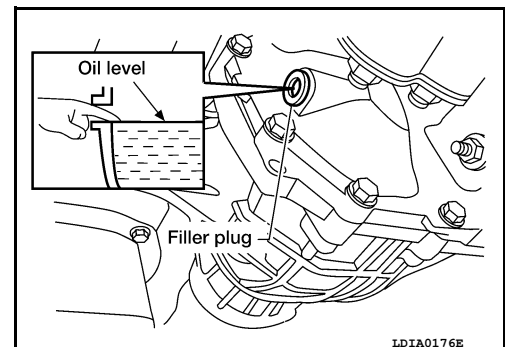

3. Install the filler plug with sealant applied on the threads to the front final drive assembly. Tighten to the specified torque. Refer to [DLN-215, "Disassembly and Assembly"](#).
  - Use High Performance Thread Sealant or equivalent. Refer to [GI-17, "Recommended Chemical Products and Sealants"](#).

# CHASSIS AND BODY MAINTENANCE

< PERIODIC MAINTENANCE >

## FRONT DIFFERENTIAL GEAR OIL : Checking Differential Gear Oil

INFOID:000000008633171

### DIFFERENTIAL GEAR OIL LEAKAGE AND LEVEL

1. Make sure that differential gear oil is not leaking from the front final drive assembly or around it.
2. Check the differential gear oil level from the filler plug hole as shown.

**CAUTION:**

**Do not start engine while checking differential gear oil level.**

3. Install the filler plug with sealant applied on the threads to the front final drive assembly. Tighten to the specified torque. Refer to [DLN-215, "Disassembly and Assembly"](#).
  - Use High Performance Thread Sealant or equivalent. Refer to [GI-17, "Recommended Chemical Products and Sealants"](#).

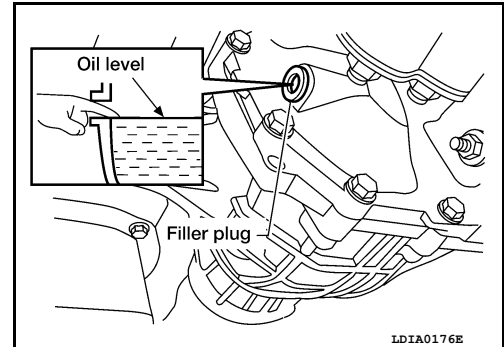

## REAR DIFFERENTIAL GEAR OIL

### REAR DIFFERENTIAL GEAR OIL : Changing Differential Gear Oil

INFOID:000000008633172

#### DRAINING

1. Stop the engine.
2. Remove the drain plug and gasket from the rear final drive assembly to drain the differential gear oil.
3. Install the drain plug with a new gasket to the rear final drive assembly. Tighten to the specified torque. Refer to [DLN-251, "Disassembly and Assembly"](#).

**CAUTION:**

**Do not reuse gasket.**

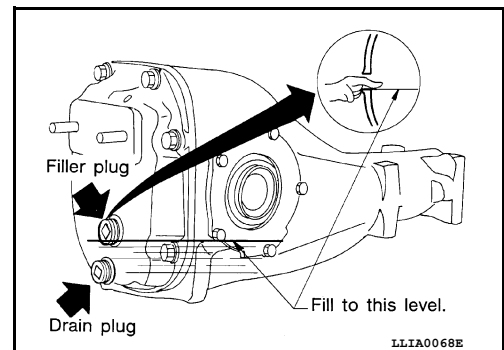

#### FILLING

1. Remove the filler plug and gasket from the rear final drive assembly.
2. Fill the rear final drive assembly with new differential gear oil until the level reaches the specified level near the filler plug hole.

**Differential gear oil grade and capacity**

**: Refer to [MA-17, "FOR USA AND CANADA : Fluids and Lubricants"](#) (United States and Canada), [MA-18, "FOR MEXICO : Fluids and Lubricants"](#) (Mexico).**

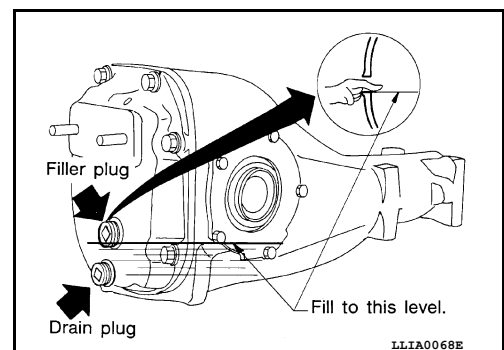

3. Install the filler plug with a new gasket on it to the rear final drive assembly. Tighten to the specified torque. Refer to [DLN-251, "Disassembly and Assembly"](#).

**CAUTION:**

**Do not reuse gasket.**

### REAR DIFFERENTIAL GEAR OIL : Checking Differential Gear Oil

INFOID:000000008633173

#### OIL LEAKAGE AND OIL LEVEL

1. Make sure that differential gear oil is not leaking from the rear final drive assembly or around it.

# CHASSIS AND BODY MAINTENANCE

## < PERIODIC MAINTENANCE >

2. Check the differential gear oil level from the filler plug hole as shown.

**CAUTION:**

**Do not start engine while checking differential gear oil level.**

3. Install the filler plug with a new gasket on it to the rear final drive assembly. Tighten to the specified torque. Refer to [DLN-251](#), "[Disassembly and Assembly](#)".

**CAUTION:**

**Do not reuse gasket.**

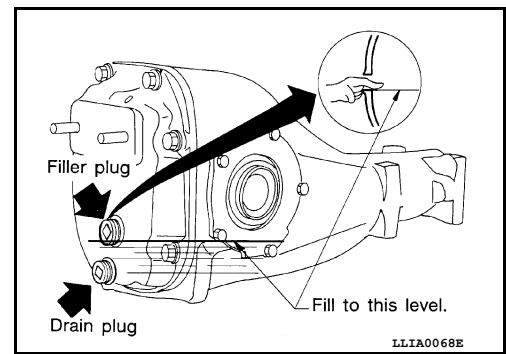

## WHEELS

### WHEELS : Balancing Wheels

INFOID:000000008633174

### BALANCING WHEELS (ADHESIVE WEIGHT TYPE)

#### Preparation Before Adjustment

Remove inner and outer balance weights from the road wheel using releasing agent, remove double-faced adhesive tape from the road wheel.

**CAUTION:**

- **Be careful not scratch the road wheel during removal.**
- **After removing double-faced adhesive tape, wipe clean traces of releasing agent from the road wheel.**

#### Wheel Balance Adjustment

**CAUTION:**

- **DO NOT use center hole cone-type clamping machines to hold the wheel assembly during tire removal/installation or balancing or damage to the wheel paint, cladding or chrome may result. Use only rim-type or universal lug-type clamping machines to hold the wheel assembly during servicing.**
- If a balancer machine has an adhesive weight mode setting, select the adhesive weight mode setting and skip Step 2. below. If a balancer machine only has the clip-on (rim flange) weight mode setting, follow Step 2. to calculate the correct size adhesive weight.

1. Set road wheel on balancer machine using the center hole as a guide. Start the balancer machine.
2. For tire balance machines that only have a clip-on (rim flange) weight mode setting, follow this step to calculate the correct size adhesive weight to use. When inner and outer imbalance values are shown on the balancer machine indicator, multiply outer imbalance value by 5/3 (1.67) to determine balance weight that should be used. Select the outer balance weight with a value closest to the calculated value above and install in to the designated outer position of, or at the designated angle in relation to the road wheel.

- a. Indicated imbalance value  $\times 5/3$  (1.67) = balance weight to be installed

**Calculation example:**

$23 \text{ g (0.81 oz)} \times 5/3 (1.67) = 38.33 \text{ g (1.35 oz)} \Rightarrow 40 \text{ g (1.41 oz)}$   
balance weight (closer to calculated balance weight value)

**NOTE:**

Note that balance weight value must be closer to the calculated balance weight value.

**Example:**

$37.4 \Rightarrow 35 \text{ g (1.23 oz)}$

$37.5 \Rightarrow 40 \text{ g (1.41 oz)}$

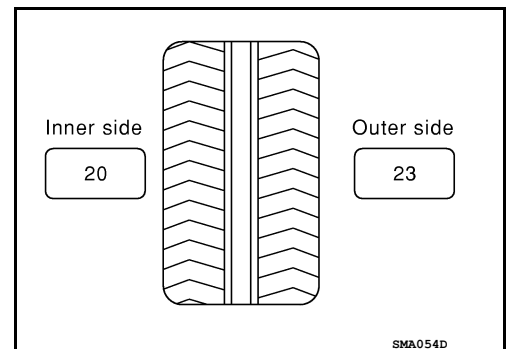

# CHASSIS AND BODY MAINTENANCE

## < PERIODIC MAINTENANCE >

3. Install balance weight in the position shown.

**CAUTION:**

- Do not install the inner balance weight before installing the outer balance weight.
- Before installing the balance weight, be sure to clean the mating surface of the road wheel.
- When installing balance weight (1) to road wheel, set it into the grooved area (A) on the inner wall of the road wheel as shown so that the balance weight center (B) is aligned with the balancer machine indication position (angle) (C).

**CAUTION:**

- Always use genuine NISSAN adhesive balance weights.
- Balance weights are non-reusable; always replace with new ones.
- Do not install more than three sheets of balance weight.

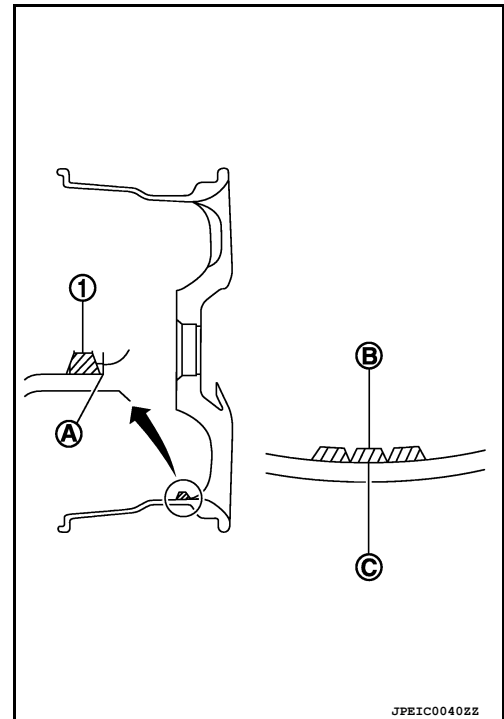

4. If calculated balance weight value exceeds 50 g (1.76 oz), install two balance weight sheets in line with each other as shown.

**CAUTION:**

**Do not install one balance weight sheet on top another.**

5. Start balancer machine again.

6. Install balance weight on inner side of road wheel in the balancer machine indication position (angle).

**CAUTION:**

**Do not install more than two balance weights.**

7. Start balancer machine. Make sure that inner and outer residual imbalance values are 5 g (0.17 oz) each or below.

8. If either residual imbalance value exceeds 5 g (0.17 oz), repeat installation procedures.

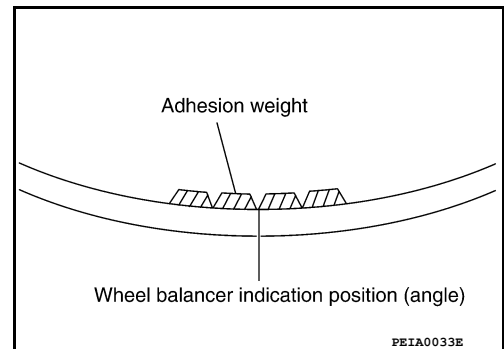

Wheel balance	Dynamic (At flange)	Static (At flange)
Maximum allowable imbalance	Refer to <a href="#">WT-55, "Road Wheel"</a> .	

## WHEELS : Rotation

INFOID:000000008633175

### TIRE ROTATION

- Follow the maintenance schedule for tire rotation service intervals. Refer to [MA-10, "FOR USA AND CANADA : Introduction of Periodic Maintenance"](#) (United States and Canada), [MA-14, "FOR MEXICO : Introduction of Periodic Maintenance"](#) (Mexico).
- Rotate the wheel and tires front to back in the pattern as shown. When installing the wheel and tires, tighten the wheel nuts diagonally to the specified torque.

**Wheel nut tightening torque : 133 N·m (14 kg·m, 98 ft·lb)**

**CAUTION:**

- Do not include the spare wheel and tire when rotating the wheel and tires.

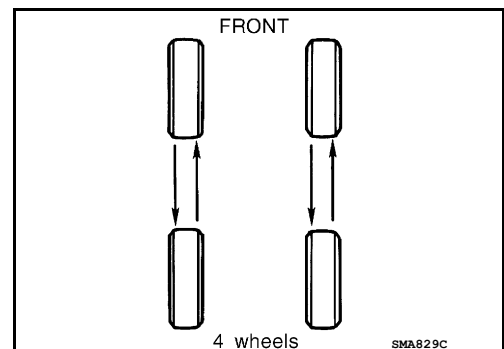

A  
B  
C  
D  
E  
F  
G  
H  
I  
J  
K  
L  
M  
N  
O

MA

# CHASSIS AND BODY MAINTENANCE

## < PERIODIC MAINTENANCE >

- When installing the wheel nuts, tighten them diagonally by dividing the work two to three times in order to prevent the wheels from developing any distortion.
- Be careful not to tighten the wheel nuts to a torque exceeding specification to prevent strain on the disc rotor.
- Use genuine NISSAN wheel nuts for aluminum wheels.

## BRAKE FLUID LEVEL AND LEAKS

### BRAKE FLUID LEVEL AND LEAKS : On Board Inspection

INFOID:000000008633176

#### LEVEL CHECK

- Make sure the fluid level in reservoir tank is between MAX and MIN lines as shown.
- Visually check around reservoir tank for fluid leaks.
- If fluid level is excessively low, check brake system for leaks.
- If brake warning lamp remains illuminated after parking brake pedal is released, check brake system for fluid leaks.

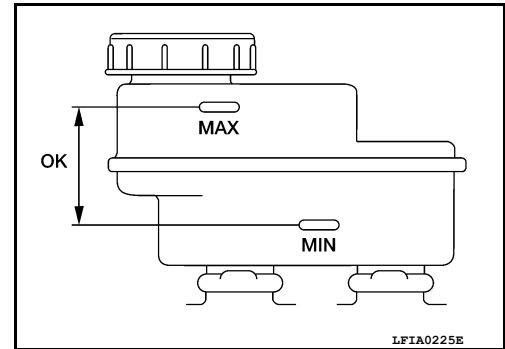

## BRAKE LINES AND CABLES

### BRAKE LINES AND CABLES : Checking Brake Line and Cables

INFOID:000000008633177

1. Check the brake lines and hoses for cracks, deterioration, and other damage. Replace any damaged parts.  
**CAUTION:**  
If brake fluid leaks are visible around the brake line joints, retighten the joint, or replace damaged parts as necessary.
2. Check for brake fluid leaks by fully depressing brake pedal while engine is running.

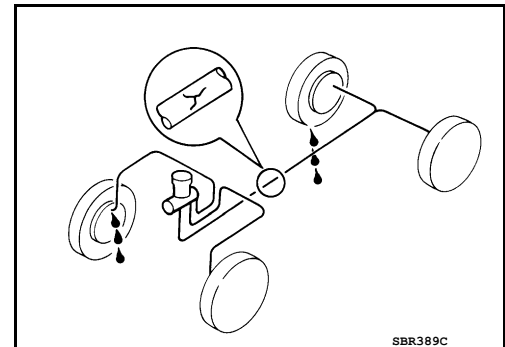

## DISC BRAKE

### DISC BRAKE : Front Brake Pad Inspection

INFOID:000000008633178

#### PAD WEAR

Check pad thickness from an inspection hole on cylinder body. Check using a scale if necessary.

**Standard thickness** : Refer to [BR-46, "Front Disc Brake"](#).

**Repair limit thickness** : Refer to [BR-46, "Front Disc Brake"](#).

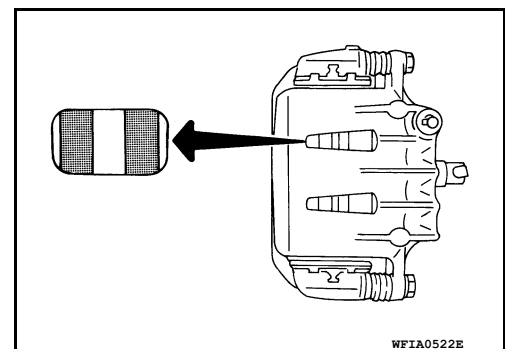

### DISC BRAKE : Front Brake Rotor Inspection

INFOID:000000008633179

#### VISUAL

Check surface of disc rotor for uneven wear, cracks, and serious damage. Replace as necessary.

# CHASSIS AND BODY MAINTENANCE

## < PERIODIC MAINTENANCE >

### THICKNESS

Check thickness of the disc rotor using a micrometer. Replace disc rotor if thickness is less than the wear limit.

- Standard thickness** : Refer to [BR-46, "Front Disc Brake"](#).
- Repair limit thickness** : Refer to [BR-46, "Front Disc Brake"](#).
- Thickness variation (Measured at 8 positions)** : Refer to [BR-46, "Front Disc Brake"](#).

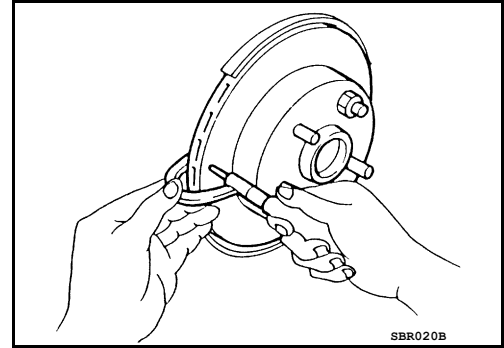

### DISC BRAKE : Rear Brake Pad Inspection

INFOID:000000008633180

#### PAD WEAR

Check pad thickness from an inspection hole on cylinder body. Check using a scale if necessary.

- Standard thickness** : Refer to [BR-46, "Rear Disc Brake"](#).
- Repair limit thickness** : Refer to [BR-46, "Rear Disc Brake"](#).

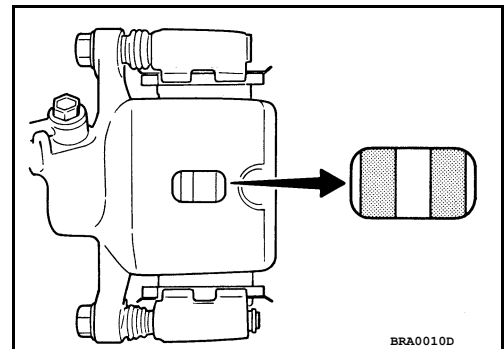

### DISC BRAKE : Rear Brake Rotor Inspection

INFOID:000000008633181

#### VISUAL

Check surface of disc rotor for uneven wear, cracks, and serious damage. Replace as necessary.

#### THICKNESS

Check the thickness of the disc rotor using a micrometer. Replace disc rotor if the thickness is less than the wear limit.

- Standard thickness** : Refer to [BR-46, "Rear Disc Brake"](#).
- Repair limit thickness** : Refer to [BR-46, "Rear Disc Brake"](#).
- Thickness variation (Measured at 8 positions)** : Refer to [BR-46, "Rear Disc Brake"](#).

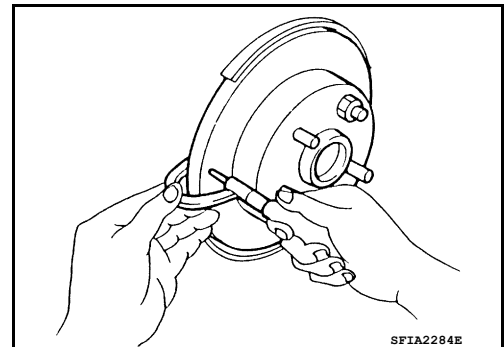

### STEERING GEAR AND LINKAGE

#### STEERING GEAR AND LINKAGE : Checking Steering Gear and Linkage

INFOID:000000008633182

#### STEERING GEAR

A  
B  
C  
D  
E  
F  
G  
H  
I  
J  
K  
L  
M  
N  
O  
MA

# CHASSIS AND BODY MAINTENANCE

## < PERIODIC MAINTENANCE >

- Check the steering gear housing for looseness, damage, and oil leakage as shown.
- Check the steering column connections for looseness.

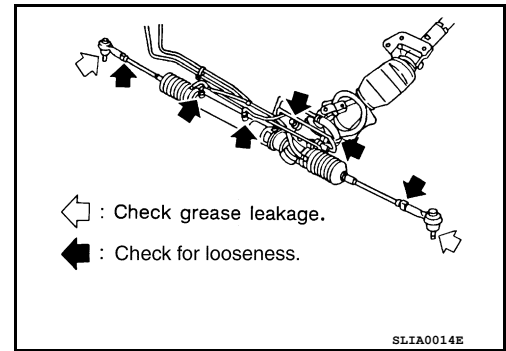

## STEERING LINKAGE

- Check the ball joint, dust cover and other component parts for looseness, wear, damage, and grease leakage.

## POWER STEERING FLUID AND LINES

### POWER STEERING FLUID AND LINES : Checking Fluid Level

INFOID:000000008633183

Check power steering fluid level with engine off, referring to the scale on reservoir tank.

Use HOT range for fluid temperatures of 50° – 80°C (122° – 176°F).

Use COLD range for fluid temperatures of 0° – 30°C (32° – 86°F).

#### CAUTION:

- Do not overfill.
- Do not reuse any power steering fluid.
- Use the recommended power steering fluid or equivalent. Refer to [MA-17, "FOR USA AND CANADA : Fluids and Lubricants"](#).

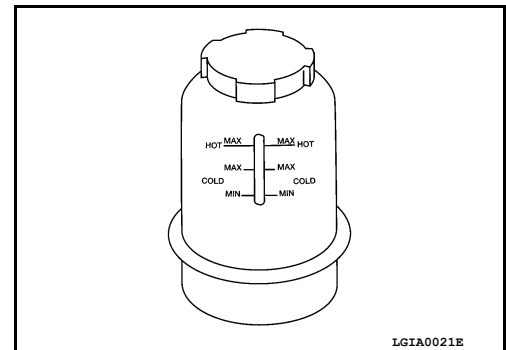

### POWER STEERING FLUID AND LINES : Checking Fluid Leakage

INFOID:000000008633184

Check the hydraulic piping lines for improper attachment and for leaks, cracks, damage, loose connections, chafing or deterioration.

1. Run engine until fluid temperature reaches 50° – 80°C (122° – 176°F) in reservoir tank. Keep engine speed idle.
2. Turn steering wheel right-to-left several times.
3. Hold steering wheel at each "lock" position for five seconds to check fluid leakage.

#### CAUTION:

**Do not hold steering wheel in a locked position for more than 10 seconds. (There is the possibility that oil pump may be damaged.)**

4. If fluid leakage at connections is noticed, then loosen flare nut and then retighten. Do not over tighten connector as this can damage O-ring, washer and connector.
5. If fluid leakage from oil pump is noticed, check oil pump. Refer to [ST-15](#).
6. Check steering gear boots for accumulation of fluid indicating a leak from the steering gear.

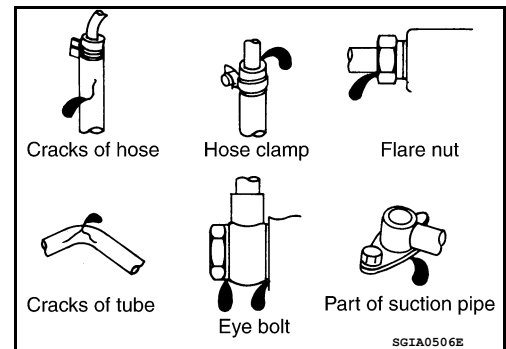

## AXLE AND SUSPENSION PARTS

### AXLE AND SUSPENSION PARTS : Checking Axle and Suspension Parts

INFOID:000000008633185

#### FRONT AND REAR AXLE AND SUSPENSION PARTS

Check front and rear axle and suspension parts for excessive play, cracks, wear or other damage.



## CHASSIS AND BODY MAINTENANCE

### < PERIODIC MAINTENANCE >

- Shake each wheel to check for excessive play.
- Rotate each wheel to check for abnormal noise.

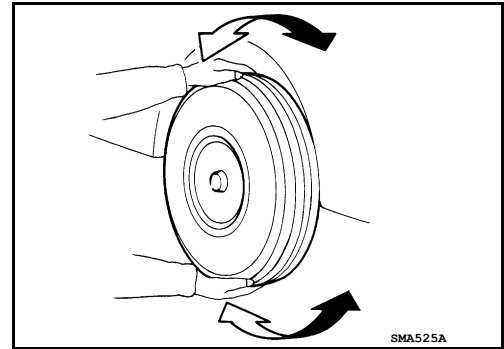

- Check the axle and suspension nuts and bolts for looseness.
- Check the strut and shock absorber for oil leakage or other damage.
- Check the suspension ball joints for grease leakage and ball joint dust cover for cracks or other damage.

### DRIVE SHAFT

- Check drive shaft mounting point and joint for looseness and other damage.
- Check boot for cracks and other damage.

#### **CAUTION:**

**Replace entire drive shaft assembly when noise or vibration occur from drive shaft**

### LOCKS AND HINGES

# CHASSIS AND BODY MAINTENANCE

< PERIODIC MAINTENANCE >

## LOCKS AND HINGES : Lubricating Locks, Hinges and Hood Latches

INFOID:000000008633186

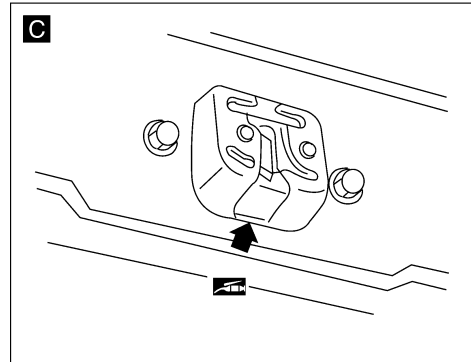
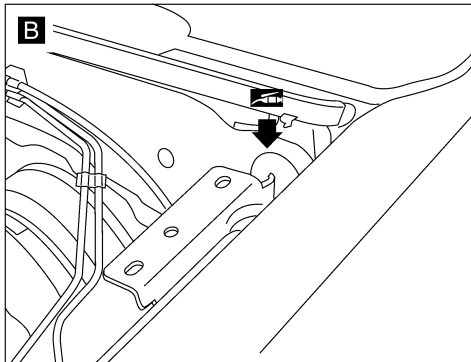
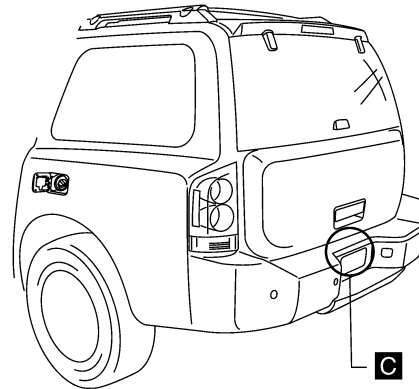
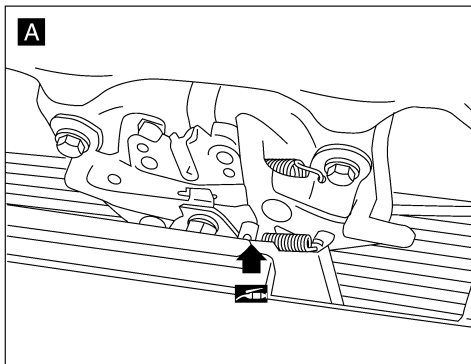
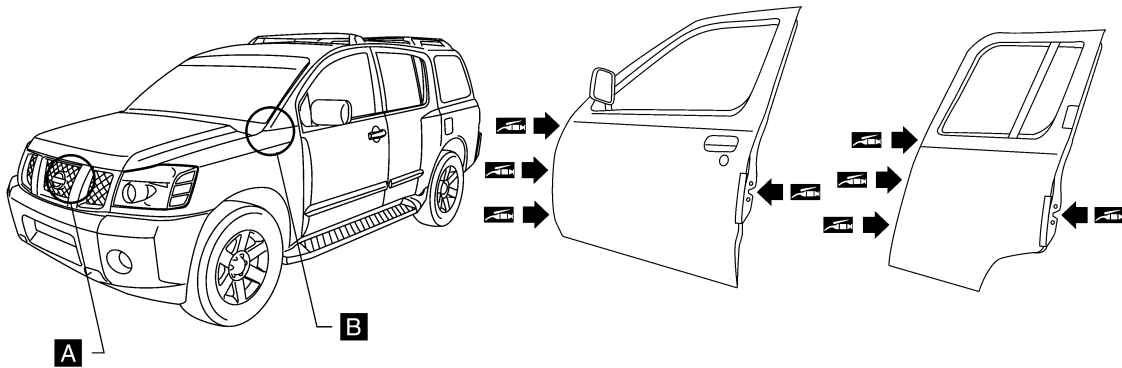

WLIA0015E

### NOTE:

Lubricate the locations shown with a suitable multi-purpose grease.

## SEAT BELT, BUCKLES, RETRACTORS, ANCHORS AND ADJUSTERS

### SEAT BELT, BUCKLES, RETRACTORS, ANCHORS AND ADJUSTERS : Checking Seat Belts, Buckles, Retractors, Anchors and Adjusters

INFOID:000000008633187

Check the seat belt buckles, webbing, retractors, anchors and adjusters. Replace any seat belt assembly as necessary. Refer to [SB-4. "Inspection"](#).

- Check the seat belt anchors for loose mounting bolts, damage, or excessive wear.
- Check the seat belt webbing for any damage, cuts, fraying, or excessive wear.
- Check the retractor for smooth operation.

## CHASSIS AND BODY MAINTENANCE

### < PERIODIC MAINTENANCE >

- Check the function of the buckles by inserting the seat belt tongue and checking for proper engagement of the buckle and press the button on the buckle to check for proper release of the seat belt tongue.

**CAUTION:**

- **After any collision, inspect all seat belt assemblies, including retractors and other attached components, such as the guide rail set. NISSAN recommends replacing all seat belt assemblies in use during a collision, unless they are not damaged and are inspected to confirm they are operating properly after a minor collision.**

**Also inspect all seat belt assemblies that are not in use during a collision, and replace any components if damaged or not operating properly. The seat belt pre-tensioner should be replaced even if the seat belts are not in use during a frontal collision where the driver and passenger air bags have been deployed.**

- **If any component of the seat belt assembly is suspected of being damaged or not operating properly, do not repair the component. Replace the components as an assembly.**
- **If the seat belt webbing is cut, frayed, or damaged then replace the seat belt assembly.**
- **Do not lubricate the seat belt buckle or tongue.**
- **When replacing any seat belt assembly always use a Genuine NISSAN seat belt assembly.**

A  
B  
C  
D  
E  
F  
G  
H  
I  
J  
K  
L  
M  
N  
O

MA