

SECTION **SB**
SEAT BELT

A
B
C
D
E
F
G
SB
I
J
K
L
M
N
O
P

CONTENTS

| | | | |
|--|---|---|----|
| PRECAUTION | 2 | For Side and Rollover Collision | 9 |
| PRECAUTIONS | 2 | REMOVAL AND INSTALLATION | 13 |
| Precaution for Supplemental Restraint System (SRS) "AIR BAG" and "SEAT BELT PRE-TENSIONER" | 2 | SEAT BELTS | 13 |
| Precaution for Seat Belt Service | 2 | Removal and Installation of Front Seat Belt | 13 |
| Precaution Necessary for Steering Wheel Rotation After Battery Disconnect | 2 | Removal and Installation of Second Row Seat Belt | 15 |
| BASIC INSPECTION | 4 | Removal and Installation of Third Row Seat Belt | 16 |
| COMPONENT INSPECTION | 4 | LATCH (LOWER ANCHORS AND TETHER FOR CHILDREN) SYSTEM | 20 |
| Inspection | 4 | Removal and Installation | 20 |
| COLLISION DIAGNOSIS | 7 | TOP TETHER STRAP CHILD RESTRAINT | 21 |
| For Frontal Collision | 7 | Removal and Installation | 21 |

PRECAUTIONS

< PRECAUTION >

PRECAUTION

PRECAUTIONS

Precaution for Supplemental Restraint System (SRS) "AIR BAG" and "SEAT BELT PRE-TENSIONER"

INFOID:000000008632224

The Supplemental Restraint System such as "AIR BAG" and "SEAT BELT PRE-TENSIONER", used along with a front seat belt, helps to reduce the risk or severity of injury to the driver and front passenger for certain types of collision. This system includes seat belt switch inputs and dual stage front air bag modules. The SRS system uses the seat belt switches to determine the front air bag deployment, and may only deploy one front air bag, depending on the severity of a collision and whether the front occupants are belted or unbelted. Information necessary to service the system safely is included in the SR and SB section of this Service Manual.

WARNING:

- To avoid rendering the SRS inoperative, which could increase the risk of personal injury or death in the event of a collision which would result in air bag inflation, all maintenance must be performed by an authorized NISSAN/INFINITI dealer.
- Improper maintenance, including incorrect removal and installation of the SRS, can lead to personal injury caused by unintentional activation of the system. For removal of Spiral Cable and Air Bag Module, see the SR section.
- Do not use electrical test equipment on any circuit related to the SRS unless instructed to in this Service Manual. SRS wiring harnesses can be identified by yellow and/or orange harnesses or harness connectors.

PRECAUTIONS WHEN USING POWER TOOLS (AIR OR ELECTRIC) AND HAMMERS

WARNING:

- When working near the Airbag Diagnosis Sensor Unit or other Airbag System sensors with the Ignition ON or engine running, DO NOT use air or electric power tools or strike near the sensor(s) with a hammer. Heavy vibration could activate the sensor(s) and deploy the air bag(s), possibly causing serious injury.
- When using air or electric power tools or hammers, always switch the Ignition OFF, disconnect the battery, and wait at least 3 minutes before performing any service.

Precaution for Seat Belt Service

INFOID:000000008632225

CAUTION:

- Before removing the seat belt pre-tensioner assembly, turn the ignition switch OFF, disconnect both battery terminals and wait at least three minutes. For approximately three minutes after the battery terminals have been removed, it is still possible for the air bag and seat belt pre-tensioner to deploy. Therefore, do not attempt work on any SRS connectors or wires until at least three minutes have passed.
- After replacing or reinstalling seat belt pre-tensioner assembly or reconnecting seat belt pre-tensioner assembly connector, make sure entire SRS operates properly. Refer to [SRC-13, "SRS Operation Check"](#).
- Do not disassemble buckle or seat belt assembly.
- Replace anchor bolts if they are deformed or worn out.
- Do not oil tongue or buckle.
- If any component of seat belt assembly is questionable, do not repair. Replace the whole seat belt assembly.
- If webbing is cut, frayed or damaged, replace seat belt assembly.
- When replacing seat belt assembly, use a genuine NISSAN seat belt assembly.

Precaution Necessary for Steering Wheel Rotation After Battery Disconnect

INFOID:000000008632226

NOTE:

- This Procedure is applied only to models with Intelligent Key system and NATS (NISSAN ANTI-THEFT SYSTEM).
- Remove and install all control units after disconnecting both battery cables with the ignition knob in the "LOCK" position.

PRECAUTIONS

< PRECAUTION >

- Always use CONSULT to perform self-diagnosis as a part of each function inspection after finishing work. If DTC is detected, perform trouble diagnosis according to self-diagnostic results.
- For models equipped with the Intelligent Key system and NATS, an electrically controlled steering lock mechanism is adopted on the key cylinder.
- For this reason, if the battery is disconnected or if the battery is discharged, the steering wheel will lock and steering wheel rotation will become impossible.
- If steering wheel rotation is required when battery power is interrupted, follow the procedure below before starting the repair operation.

OPERATION PROCEDURE

1. Connect both battery cables.
NOTE:
Supply power using jumper cables if battery is discharged.
2. Use the Intelligent Key or mechanical key to turn the ignition switch to the "ACC" position. At this time, the steering lock will be released.
3. Disconnect both battery cables. The steering lock will remain released and the steering wheel can be rotated.
4. Perform the necessary repair operation.
5. When the repair work is completed, return the ignition switch to the "LOCK" position before connecting the battery cables. (At this time, the steering lock mechanism will engage.)
6. Perform a self-diagnosis check of all control units using CONSULT.

A
B
C
D
E
F
G
I
J
K
L
M
N
O
P

SB

COMPONENT INSPECTION

< BASIC INSPECTION >

BASIC INSPECTION

COMPONENT INSPECTION

Inspection

INFOID:000000008929298

AFTER A COLLISION

WARNING:

Inspect all seat belt assemblies including retractors and attaching hardware after any collision. NISSAN/INFINITI recommends that all seat belt assemblies in use during a collision be replaced unless the collision was minor and the belts show no damage and continue to operate properly. Failure to do so could result in serious personal injury in an accident. Seat belt assemblies not in use during a collision should also be replaced if either damage or improper operation is noted. Seat belt pretensioners should be replaced even if the seat belts are not in use during a frontal collision in which the air bags are deployed.

Replace any seat belt assembly (including anchor bolts) if:

- The seat belt was in use at the time of a collision (except for minor collisions and the belts, retractors and buckles show no damage and continue to operate properly).
- The seat belt was damaged in an accident (i.e. torn webbing, bent retractor or guide, etc.).
- The seat belt attaching point is damaged in an accident. Inspect the seat belt attaching area for damage or distortion and repair if necessary before installing a new seat belt assembly.
- Anchor bolts are deformed or worn out.
- The seat belt pre-tensioner should be replaced even if the seat belts are not in use during the collision in which the air bags are deployed.

PRELIMINARY CHECKS

1. Check the seat belt warning lamp for proper operation per the following:
 - a. Turn ignition switch ON. The seat belt warning lamp should illuminate.
 - b. Fasten driver seat belt. The seat belt warning lamp should turn OFF.
 2. If the air bag warning lamp is blinking, perform self-diagnosis with CONSULT and air bag warning lamp. Refer to [SRC-15. "Trouble Diagnosis without CONSULT"](#).
 3. Check that the seat belt retractor, seat belt anchor and buckle bolts are tightened firmly.
 4. Check the shoulder seat belt guide and shoulder belt height adjuster for front seats. Check that guide swivels freely and that webbing lays flat and does not bind in guide. Check that height adjuster operates properly and holds securely.
 5. Check retractor operation:
 - a. Fully extend the seat belt webbing and check for twists, tears or other damage.
 - b. Allow the seat belt to retract. Check that webbing returns smoothly and completely into the retractor. If the seat belt does not return smoothly, wipe the inside of the loops with a clean paper cloth. Dirt build-up in the loops of the upper anchors can cause the seat belts to retract slowly.
 - c. Fasten the seat belt. Check that seat belt returns smoothly and completely to the retractor. If the webbing does not return smoothly, the cause may be an accumulation of dust or dirt. Use the "SEAT BELT TAPE SET" and perform the following steps.
 - d. Inspect the front seat belt D-ring anchor
 1. Pull the seat belt out to a length of 500 mm (19.69 in) or more.
 2. Hold the seat belt at the center pillar webbing opening with a clip or other device.
 3. Pass a thin wire through the D-ring anchor webbing opening. Hold both ends of the wire and pull it tightly while moving it up and down several times along the webbing opening surface to remove dirt stuck there.
 4. Any dirt that cannot be removed with the wire can be removed by cleaning the opening with a clean cloth.
 5. Apply tape at the point where the webbing contacts the D-ring anchor webbing opening.
- NOTE:**
Apply the tape so that there is no slack or wrinkling.
6. Remove the clip holding the seat belt and check that the webbing returns smoothly.
 6. Repeat steps above if necessary to check the other seat belts.

COMPONENT INSPECTION

< BASIC INSPECTION >

SEAT BELT RETRACTOR ON-VEHICLE CHECK

Emergency Locking Retractors (ELR) and Automatic Locking Retractors (ALR)

NOTE:

All seat belt retractors are Emergency Locking Retractors (ELR) type. In an emergency (sudden stop) the retractor will lock and prevent the webbing from extending any further. All 3-point type seat belt retractors except the driver seat belt also have an Automatic Locking Retractors (ALR) mode. The ALR mode (also called child restraint mode) is used when installing child seats. The ALR mode is activated when the seat belt is fully extended. When the webbing is then retracted partially, the ALR mode automatically locks the seat belt in a specific position so the webbing cannot be extended any further. To cancel the ALR mode, allow the seat belt to fully wind back into the retractor.

Check the seat belt retractors with the following test(s) to determine if a retractor assembly is operating properly.

ELR Function Stationary Check

Grasp the shoulder webbing and pull forward quickly. The retractor should lock and prevent the belt from extending further.

ALR Function Stationary Check

1. Pull out the entire length of seat belt from retractor until a click is heard.
2. Retract the webbing partially. A clicking noise should be heard as the webbing retracts, indicating that the retractor is in the Automatic Locking Retractors (ALR) mode.
3. Grasp the seat belt and try to pull out the retractor. The webbing must lock and not extend any further. If it does not operate normally, replace the retractor assembly.
4. Allow the entire length of the webbing to retract to cancel the automatic locking mode.

ELR Function Moving Check

WARNING:

Perform the following test in a safe, open area clear of other vehicles and obstructions (for example, a large, empty parking lot). Road surface must be paved and dry. Never perform the following test on wet or gravel roads or on public streets and highways. This could result in an accident and serious personal injury. The driver and passenger must be prepared to brace themselves in the event that the retractor does not lock.

1. Fasten driver seat belt. Buckle a passenger into the seat for the belt that is to be tested.
2. Proceed to the designated safe area.
3. Drive the vehicle at approximately 16 km/h (10 mph). Notify any passengers of a pending sudden stop and the driver and passenger must be prepared to brace themselves in the event that the retractor does not lock. Apply brakes firmly and make a very hard stop.

During stopping, seat belts should lock and not be extended. If the seat belt retractor assembly does not lock, perform the retractor off-vehicle check.

FRONT SEAT BELT RETRACTOR OFF-VEHICLE CHECK

1. Remove the front seat belt retractor. Refer to [SB-13, "Removal and Installation of Front Seat Belt"](#).
2. Slowly pull out webbing while tilting the seat belt retractor forward from the mounted position without twisting the seat belt retractor as shown.

A : The webbing can be pulled out if the retractor is tilted 15° degree or less.

B : The webbing can not be pulled out if the retractor is tilted 35° degrees or more.

NOTE:

A and B show tilting angles.

⇐: Front

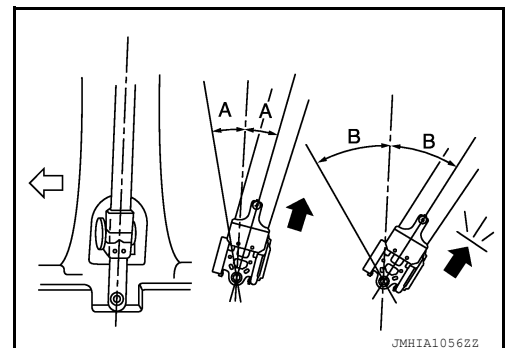

3. Replace the seat belt retractor if it does not operate within specifications.

REAR SEAT BELT OUTER RETRACTOR OFF-VEHICLE CHECK

COMPONENT INSPECTION

< BASIC INSPECTION >

1. Remove the rear seat belt retractor. Refer to [SB-15. "Removal and Installation of Second Row Seat Belt" \(SECOND ROW\)](#) or [SB-16. "Removal and Installation of Third Row Seat Belt" \(THIRD ROW\)](#).
2. Slowly pull out webbing while tilting the seat belt retractor forward from the mounted position without twisting the seat belt retractor as shown.

A : The webbing can be pulled out if the retractor is tilted 15° degree or less.

B : The webbing can not be pulled out if the retractor is tilted 35° degrees or more.

NOTE:

A and B show tilting angles.

↔: Front

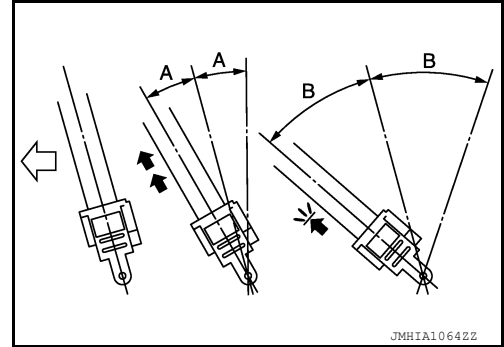

3. Replace the seat belt retractor if it does not operate within specifications.

REAR SEAT BELT CENTER RETRACTOR OFF-VEHICLE CHECK

1. Remove the rear seat belt center retractor. Refer to [SB-16. "Removal and Installation of Third Row Seat Belt"](#).
2. Slowly pull out webbing while tilting the seat belt retractor forward from the mounted position without twisting the seat belt retractor as shown.

A : The webbing can be pulled out if the retractor is tilted 15° degree or less.

B : The webbing can not be pulled out if the retractor is tilted 35° degrees or more.

NOTE:

A and B show tilting angles.

↔: Front

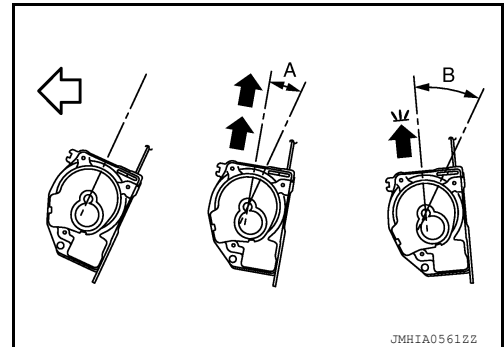

3. Replace the seat belt retractor if it does not operate within specifications.

COLLISION DIAGNOSIS

< BASIC INSPECTION >

COLLISION DIAGNOSIS

For Frontal Collision

INFOID:000000008929299

FOR FRONTAL COLLISION: When SRS is activated in a collision

CAUTION:

Due to varying models and option levels, not all parts listed in the chart below apply to all vehicles.

WORK PROCEDURE

1. Before performing any of the following steps, ensure that all vehicle body and structural repairs have been completed.
2. Replace the diagnosis sensor unit.
3. Remove the front air bag modules, crash zone sensor assembly, bracket and seat belt pre-tensioner assemblies.
4. Check the SRS components using the table below:
Replace any SRS components showing visible signs of damage. (dents, cracks and deformation, etc.)
5. Install new front air bag modules, crash zone sensor assembly, bracket and seat belt pre-tensioner assemblies.
6. Perform self-diagnosis using CONSULT or air bag warning lamp. Refer to [SRC-15, "Self-Diagnosis Function \(Without CONSULT\)"](#) for details.
Ensure entire SRS operates properly.
7. After the work is completed, perform self-diagnosis to check that no malfunction is detected. Refer to [SRC-13, "SRS Operation Check"](#).

SRS INSPECTION (FOR FRONTAL COLLISION)

| Part | Inspection |
|---|--|
| Driver air bag module | If the driver air bag has deployed: REPLACE Install with new fasteners. |
| Front passenger air bag module (if equipped) | If the front passenger air bag has deployed: REPLACE Install with new fasteners. |
| Crash zone sensor | If any of the front air bags or seat belt pre-tensioners* have been activated: REPLACE the crash zone sensor and bracket with new fasteners. *: Confirm seat belt pre-tensioner activation using CONSULT only. |
| Seat belt pre-tensioner assemblies (All applicable locations: buckle, retractor, lap outer) | If either the driver or passenger seat belt pre-tensioner* has been activated: REPLACE all seat belt pre-tensioner assemblies with new fasteners. *: Confirm seat belt pre-tensioner activation using CONSULT only. |
| Diagnosis sensor unit | If any of the SRS components have been activated: REPLACE the diagnosis sensor unit. Install with new fasteners. |
| Steering wheel | <ol style="list-style-type: none"> 1. Visually check steering wheel for deformities. 2. Check harness (built into steering wheel) and connectors for damage, and terminals for deformities. 3. Install driver air bag module into the steering wheel to check fit and alignment with the wheel. 4. Check steering wheel for excessive free play. 5. If no damage is found, reinstall. 6. If damaged — REPLACE. |
| Spiral cable | If the driver front air bag has deployed: REPLACE the spiral cable. |
| Occupant classification system (Passenger seat) | <ol style="list-style-type: none"> 1. Remove passenger seat assembly. 2. Check control unit case for dents, cracks or deformities. 3. Check connectors and pressure sensor tube for damage, and terminals for deformities. 4. Check seat frame and cushion pan for dents or deformities. 5. If no damage is found, reinstall seat with new fasteners. 6. If damaged— REPLACE seat cushion assembly with new fasteners. |

COLLISION DIAGNOSIS

< BASIC INSPECTION >

| Part | Inspection |
|---------------------------|--|
| Harness and connectors | <ol style="list-style-type: none"> 1. Check connectors for poor connection, damage, and terminals for deformities. 2. Check harness for binding, chafing, cuts, or deformities. 3. If no damage is found, reinstall the harness and connectors. 4. If damaged — REPLACE the damaged harness. Do not attempt to repair, splice or modify any SRS harness. |
| Instrument panel assembly | If the passenger front air bag has deployed: REPLACE the instrument panel assembly. (integrated type) |

FOR FRONTAL COLLISION: When SRS is not activated in a collision

CAUTION:

Due to varying models and option levels, not all parts listed in the chart below apply to all vehicles.

WORK PROCEDURE

1. Before performing any of the following steps, ensure that all vehicle body and structural repairs have been completed.
2. Check the SRS components using the table below:
Replace any SRS components showing visible signs of damage. (dents, cracks and deformation, etc.)
3. Perform self-diagnosis using CONSULT or air bag warning lamp. Refer to [SRC-15. "Self-Diagnosis Function \(Without CONSULT\)"](#) for details.
Ensure entire SRS operates properly.
4. After the work is completed, perform self-diagnosis to check that no malfunction is detected. Refer to [SRC-13. "SRS Operation Check"](#).

SRS INSPECTION (FOR FRONTAL COLLISION)

| Part | Inspection |
|---|---|
| Driver air bag module | <p>If the driver air bag has NOT been activated:</p> <ol style="list-style-type: none"> 1. Remove driver air bag module. Check harness cover and connectors for damage, terminals for deformities, and harness for binding. 2. Install driver air bag module into the steering wheel to check fit and alignment with the wheel. 3. If no damage is found, reinstall with new fasteners. 4. If damaged — REPLACE. Install driver air bag modules with new fasteners. |
| Front passenger air bag module (if equipped) | <p>If the front passenger air bag has NOT been activated:</p> <ol style="list-style-type: none"> 1. Remove front passenger air bag module. Check harness cover and connectors for damage, terminals for deformities, and harness for binding. 2. Install front passenger air bag module into the instrument panel to check fit with the instrument panel. 3. If no damage is found, reinstall with new fasteners. 4. If damaged — REPLACE. Install front passenger air bag modules with new fasteners. |
| Crash zone sensor | <p>If the front air bags or seat belt pre-tensioners have NOT been activated:</p> <ol style="list-style-type: none"> 1. Remove the crash zone sensor. Check harness connectors for damage, terminals for deformities, and harness for binding. 2. Check for visible signs of damage (dents, cracks, deformation) of the crash zone sensor and bracket. 3. Install the crash zone sensor to check fit. 4. If no damage is found, reinstall with new fasteners. 5. If damaged — REPLACE the crash zone sensor and bracket with new fasteners. |
| Seat belt pre-tensioner assemblies (All applicable locations: buckle, retractor, lap outer) | <p>If the pre-tensioners have NOT been activated:</p> <ol style="list-style-type: none"> 1. Remove seat belt pre-tensioners. Check harness cover and connectors for damage, terminals for deformities, and harness for binding. 2. Check belts for damage and anchors for loose mounting. 3. Check retractor for smooth operation. 4. Check seat belt adjuster for damage. 5. Check for deformities of the center pillar inner. 6. If the center pillar inner has no damage, REPLACE the seat belt pre-tensioner assembly. 7. If no damage is found, reinstall seat belt pre-tensioner assembly. 8. If damaged —REPLACE. Install the seat belt pre-tensioners with new fasteners. |

COLLISION DIAGNOSIS

< BASIC INSPECTION >

| Part | Inspection |
|---|---|
| Diagnosis sensor unit | If none of the SRS components have been activated: <ol style="list-style-type: none"> 1. Check case for dents, cracks or deformities. 2. Check connectors for damage, and terminals for deformities. 3. If no damage is found, reinstall with new fasteners. 4. If damaged — REPLACE. Install diagnosis sensor unit with new fasteners. |
| Steering wheel | <ol style="list-style-type: none"> 1. Visually check steering wheel for deformities. 2. Check harness (built into steering wheel) and connectors for damage, and terminals for deformities. 3. Install driver air bag module into the steering wheel to check fit and alignment with the wheel. 4. Check steering wheel for excessive free play. 5. If no damage is found, reinstall. 6. If damaged — REPLACE. |
| Spiral cable | If the driver front air bag has not deployed: <ol style="list-style-type: none"> 1. Visually check spiral cable and combination switch for damage. 2. Check connectors and protective tape for damage. 3. Check steering wheel for noise, binding or heavy operation. 4. If no damage is found, reinstall. 5. If damaged — REPLACE. |
| Occupant classification system (Passenger seat) | <ol style="list-style-type: none"> 1. Remove passenger seat assembly. 2. Check control unit case for dents, cracks or deformities. 3. Check connectors and pressure sensor tube for damage, and terminals for deformities. 4. Check seat frame and cushion pan for dents or deformities. 5. If no damage is found, reinstall seat with new fasteners. 6. If damaged — REPLACE seat cushion assembly with new fasteners. |
| Harness and connectors | <ol style="list-style-type: none"> 1. Check connectors for poor connection, damage, and terminals for deformities. 2. Check harness for binding, chafing, cuts, or deformities. 3. If no damage is found, reinstall the harness and connectors. 4. If damaged —REPLACE the damaged harness. Do not attempt to repair, splice or modify any SRS harness. |
| Instrument panel assembly | If the passenger front air bag has NOT deployed: <ol style="list-style-type: none"> 1. Visually check instrument panel for damage. 2. If no damage is found, reinstall the instrument panel assembly. 3. If damaged—REPLACE the instrument panel assembly. |

A
B
C
D
E
F
G
SB
I
J

For Side and Rollover Collision

INFOID:000000008929300

FOR SIDE AND ROLLOVER COLLISION: When SRS is activated in a collision

CAUTION:

Due to varying models and option levels, not all parts listed in the chart below apply to all vehicles.

WORK PROCEDURE

1. Before performing any of the following steps, ensure that all vehicle body and structural repairs have been completed.
2. Replace the following components:
 - Front seat back assembly (on the side on which side air bag is activated).
 - Door finisher (on the side on which door-mounted curtain air bag is activated).
 - Pop-up roll bar assemblies and pop-up roll bar covers.
 - Side air bag (satellite) sensor LH/RH (on the side on which side air bag is activated).
 - Diagnosis sensor unit.
 - Seat belt pre-tensioner assemblies.
3. Check the SRS components and the related parts using the following table. Replace any SRS components and the related parts showing visible signs of damage (dents, cracks, deformation, etc.).
4. Perform self-diagnosis using CONSULT and "AIR BAG" warning lamp. Refer to [SRC-13, "SRS Operation Check"](#) for details. Make sure entire SRS operates properly.
5. After the work is completed, perform self-diagnosis to check that no malfunction is detected. Refer to [SRC-15, "Trouble Diagnosis without CONSULT"](#).

K
L
M
N
O
P

SRS INSPECTION (FOR SIDE AND ROLLOVER COLLISION)

COLLISION DIAGNOSIS

< BASIC INSPECTION >

| Part | Inspection |
|--|---|
| Side curtain air bag module LH | If the side curtain air bag LH has deployed: REPLACE the side curtain air bag module LH. Install with new fasteners. |
| Side curtain air bag module RH | If the side curtain air bag RH has deployed: REPLACE the side curtain air bag module RH. Install with new fasteners. |
| Front side air bag module LH | If the front side air bag LH has deployed: REPLACE front seatback assembly LH. |
| Front side air bag module RH | If the front side air bag RH has deployed: REPLACE front seatback assembly RH. |
| Side air bag (satellite) sensor (LH or RH) | If any of the SRS components have deployed: REPLACE the side air bag (satellite) sensor on the collision side with new fasteners. |
| Diagnosis sensor unit | If any of the SRS components have deployed: REPLACE the diagnosis sensor unit with new fasteners. |
| Seat belt pre-tensioner assemblies (All applicable locations: buckle, retractor, lap outer) | If either the driver or passenger seat belt pre-tensioner* has been activated: REPLACE all seat belt pre-tensioner assemblies with new fasteners. *: Confirm seat belt pre-tensioner activation using CONSULT only. |
| Center inner pillar | 1. Check the center inner pillar on the collision side for damage (dents, cracks, deformation). 2. If damaged —REPAIR the center inner pillar. |
| Seat (if equipped with front side air bag) | If either the front LH or front RH side air bag modules has been deployed: REPLACE front seatback assembly on the deployed side. |
| Trim/headlining | 1. Check for visible signs of damage (dents, cracks, deformation) of the interior trim on the collision side. 2. If damaged — REPLACE the damaged trim parts. |
| Door-mounted curtain air bag module LH | If the door-mounted curtain air bag module LH has been deployed: REPLACE the door finisher LH and door-mounted curtain air bag module. Install with new fasteners. |
| Door-mounted curtain air bag module RH | If the door-mounted curtain air bag module RH has been deployed: REPLACE the door finisher RH and door-mounted curtain air bag module. Install with new fasteners. |
| Pop-up roll bar assemblies | If the pop-up roll bar has deployed: REPLACE pop-up roll bar assemblies and pop-up roll bar covers. Install with new fasteners. |

FOR SIDE AND ROLLOVER COLLISION: When SRS is not activated in a collision

CAUTION:

Due to varying models and option levels, not all parts listed in the chart below apply to all vehicles.

WORK PROCEDURE

1. Before performing any of the following steps, ensure that all vehicle body and structural repairs have been completed.
2. Check the SRS components and the related parts using the following table.
 - If the front seat back assembly is damaged, the front seat back assembly must be replaced.
 - If the door finisher assembly is damaged, the door finisher assembly and door-mounted curtain air bag module must be replaced.
3. Perform self-diagnosis using CONSULT and "AIR BAG" warning lamp. Refer to [SRC-13, "SRS Operation Check"](#) for details. Make sure entire SRS operates properly.
4. After the work is completed, perform self-diagnosis to check that no malfunction is detected. Refer to [SRC-15, "Trouble Diagnosis without CONSULT"](#).

SRS INSPECTION (FOR SIDE AND ROLLOVER COLLISION)

COLLISION DIAGNOSIS

< BASIC INSPECTION >

| Part | Inspection | |
|--|--|----------------|
| Side curtain air bag module LH | If the side curtain air bag LH has NOT deployed: <ol style="list-style-type: none"> 1. Check for visible signs of damage (dents, tears, deformation) of the center pillar on the collision side. 2. If damaged - Remove the side curtain air bag module LH. 3. Check for visible signs of damage (tears etc.) of the side curtain air bag module LH. 4. Check harness and connectors for damage, and terminals for deformities. 5. If no damage is found, reinstall the side curtain air bag module LH with new fasteners. 6. If damaged — REPLACE the side curtain air bag module LH with new fasteners. | A B C |
| Side curtain air bag module RH | If the side curtain air bag RH has NOT deployed: <ol style="list-style-type: none"> 1. Check for visible signs of damage (dents, tears, deformation) of the center pillar on the collision side. 2. If damaged - Remove the side curtain air bag module RH. 3. Check for visible signs of damage (tears etc.) of the side curtain air bag module RH. 4. Check harness and connectors for damage, and terminals for deformities. 5. If no damage is found, reinstall the side curtain air bag module RH with new fasteners. 6. If damaged — REPLACE the side curtain air bag module RH with new fasteners. | D E |
| Front side air bag module LH | If the front LH side air bag has NOT deployed: <ol style="list-style-type: none"> 1. Check for visible signs of damage (dents, tears, deformation) of the seat back on the collision side. 2. Check harness and connectors for damage, and terminals for deformities. 3. If damaged — REPLACE the front seatback assembly LH. | F |
| Front side air bag module RH | If the front side air bag RH has NOT deployed: <ol style="list-style-type: none"> 1. Check for visible signs of damage (dents, tears, deformation) of the seat back on the collision side. 2. Check harness and connectors for damage, and terminals for deformities. 3. If damaged — REPLACE the front seatback assembly RH. | G SB |
| Side air bag (satellite) sensor (LH or RH) | If none of the SRS components have been activated: <ol style="list-style-type: none"> 1. Remove the side air bag (satellite) sensor (LH or RH) on the collision side. Check harness connectors for damage, terminals for deformities, and harness for binding. 2. Check for visible signs of damage (dents, cracks, deformation) of the side air bag (satellite) sensor (LH or RH). 3. Install the side air bag (satellite) sensor (LH or RH) to check fit. 4. If no damage is found, reinstall the side air bag (satellite) sensor (LH or RH) with new fasteners. 5. If damaged — REPLACE the side air bag (satellite) sensor (LH or RH) with new fasteners. | I J |
| Diagnosis sensor unit | If none of the SRS components have been activated: <ol style="list-style-type: none"> 1. Check case and bracket for dents, cracks or deformities. 2. Check connectors for damage, and terminals for deformities. 3. If no damage is found, reinstall the diagnosis sensor unit with new fasteners. 4. If damaged — REPLACE the diagnosis sensor unit with new fasteners. | K L |
| Seat belt pre-tensioner assemblies (All applicable locations: buckle, retractor, lap outer) | If the pre-tensioners have NOT been activated: <ol style="list-style-type: none"> 1. Remove seat belt pre-tensioners. Check harness cover and connectors for damage, terminals for deformities, and harness for binding. 2. Check belts for damage and anchors for loose mounting. 3. Check retractor for smooth operation. 4. Check seat belt adjuster for damage. 5. Check for deformities of the center pillar inner. 6. If the center pillar inner has no damage, REPLACE the seat belt pre-tensioner assembly. 7. If no damage is found, reinstall seat belt pre-tensioner assembly. 8. If damaged —REPLACE. Install the seat belt pre-tensioners with new fasteners. | M N O |
| Seat (with front side air bag) | If the front LH or front RH side air bag modules have NOT deployed: <ol style="list-style-type: none"> 1. Visually check the seat on the collision side. 2. Remove the seat on the collision side and check the following for damage and deformities. <ul style="list-style-type: none"> - Harness, connectors and terminals - Frame and recliner (for front and rear seat), and also adjuster and slides (for front seat) 3. If no damage is found, reinstall the seat. 4. If damaged— REPLACE the damaged seat parts using new fasteners. If the front seat back is damaged, the front seat back assembly must be replaced. | P |

COLLISION DIAGNOSIS

< BASIC INSPECTION >

| Part | Inspection |
|--|---|
| Center inner pillar | <ol style="list-style-type: none"> 1. Check the center inner pillar on the collision side for damage (dents, cracks, deformation, etc.). 2. If damaged - REPAIR the center inner pillar. |
| Trim/headlining | <ol style="list-style-type: none"> 1. Check for visible signs of damage (dents, cracks, deformation, etc.) of the interior trim on the collision side. 2. If damaged - REPLACE the damaged trim parts. |
| Door-mounted curtain air bag module LH | <p>If the door-mounted curtain air bag LH has NOT deployed:</p> <ol style="list-style-type: none"> 1. Check for visible signs of damage (dents, tears, deformation, etc.) of the door finisher on the collision side. 2. If damaged - REPLACE the door finisher LH with new fasteners. 3. Check for visible signs of damage (tears etc.) of the door-mounted curtain air bag module LH. 4. Check harness and connectors for damage, and terminals for deformities. 5. If no damage is found, reinstall door finisher. <p>CAUTION: When removing door mounted curtain air bag module from door finisher, do not reuse door finisher.</p> <ol style="list-style-type: none"> 6. If damaged - REPLACE the door finisher LH and door-mounted curtain air bag module LH with new fasteners. |
| Door-mounted curtain air bag module RH | <p>If the door-mounted curtain air bag RH has NOT deployed:</p> <ol style="list-style-type: none"> 1. Check for visible signs of damage (dents, tears, deformation, etc.) of the door finisher on the collision side. 2. If damaged - REPLACE the door finisher RH with new fasteners. 3. Check for visible signs of damage (tears etc.) of the door-mounted curtain air bag module RH. 4. Check harness and connectors for damage, and terminals for deformities. 5. If no damage is found, reinstall door finisher. <p>CAUTION: When removing door mounted curtain air bag module from door finisher, do not reuse door finisher.</p> <ol style="list-style-type: none"> 6. If damaged - REPLACE the door finisher RH and door-mounted curtain air bag module RH with new fasteners. |
| Pop-up roll bar | <p>If the pop-up roll bar NOT deployed:</p> <ol style="list-style-type: none"> 1. Check for visible signs of damage (dents, tears, deformation, etc.) of the pop-up roll bar. 2. If damaged - REPLACE the pop-up roll bar with new fasteners. 3. Check harness and connectors for damage, and terminals for deformities. 4. If no damage is found, reinstall the pop-up roll bar with new fasteners. 5. Check for visible signs of damage (dents, cracks, deformation, etc.) of the seatback support brace assembly. 6. If damaged - REPAIR the seatback support brace assembly. |

SEAT BELTS

< REMOVAL AND INSTALLATION >

REMOVAL AND INSTALLATION

SEAT BELTS

Removal and Installation of Front Seat Belt

INFOID:00000000863227

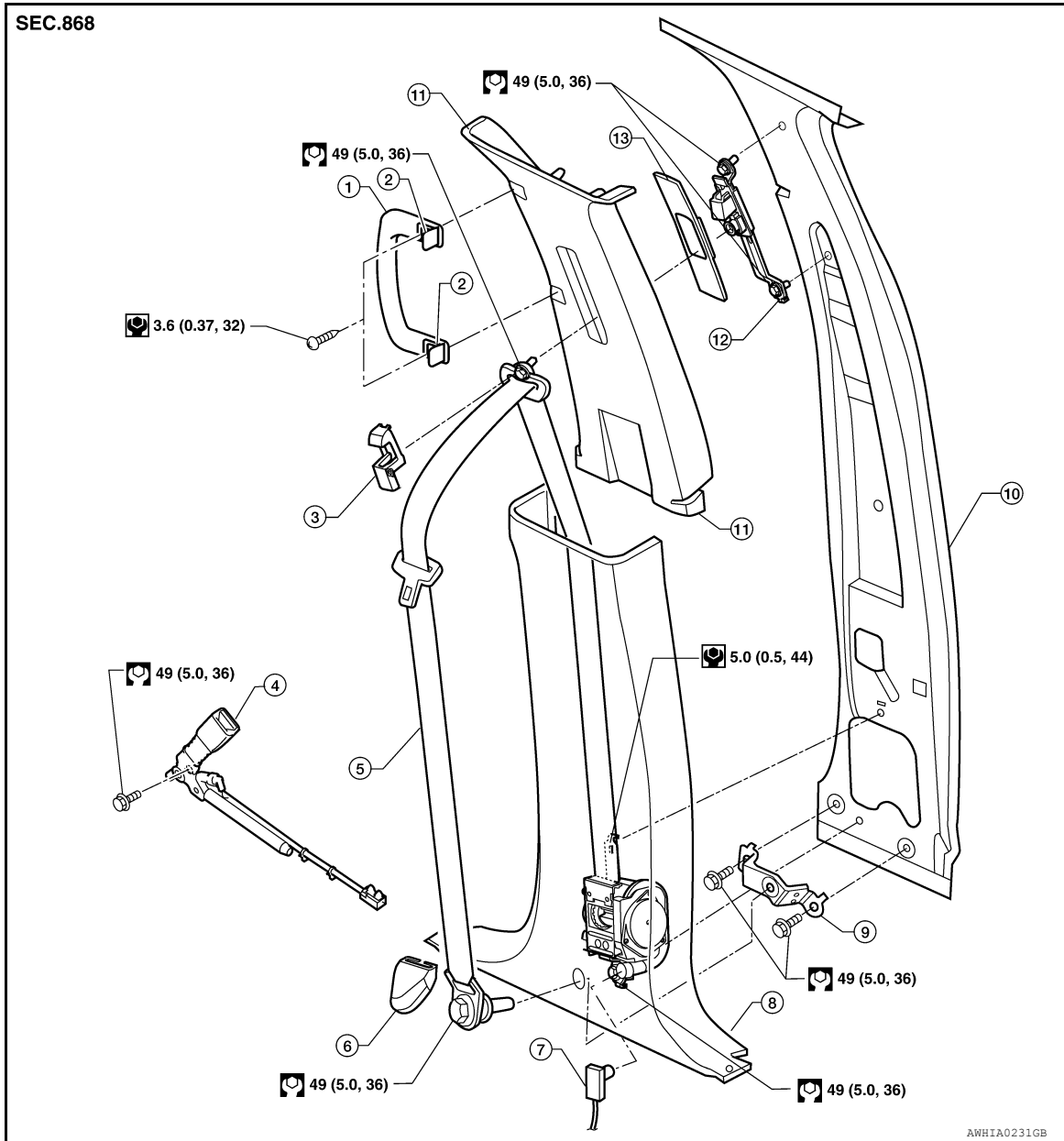

- | | | |
|--|---|-------------------------------|
| 1. Assist handle | 2. Assist handle screw cover | 3. D-ring anchor bolt cover |
| 4. Seat belt buckle | 5. Seat belt retractor and belt assembly (LH) | 6. Anchor cover |
| 7. Seat belt pre-tensioner connector | 8. Center pillar lower finisher | 9. Seat belt anchor bracket |
| 10. Center pillar | 11. Center pillar upper finisher | 12. Seat belt height adjuster |
| 13. Seat belt height adjuster finisher | | |

FRONT SEAT BELT RETRACTOR

Removal

CAUTION:

A
B
C
D
E
F
G
SB
I
J
K
L
M
N
O
P

SEAT BELTS

< REMOVAL AND INSTALLATION >

- Before servicing SRS, turn the ignition switch off, disconnect both battery terminals and wait at least three minutes.

1. Disconnect both the negative and positive battery terminals, then wait at least three minutes. Refer to [PG-77. "Removal and Installation"](#).
2. Remove the D-ring anchor bolt cover and D-ring anchor bolt.
3. Remove the center pillar lower finisher. Refer to [INT-18. "Removal and Installation"](#).
4. Remove the retractor and belt assembly anchor bolt and retractor bolt upper.
 - On RH side, disconnect the seat belt tension sensor.
5. Disconnect the harness connector from the seat belt pre-tensioner and remove the retractor and belt assembly.

CAUTION:

- For removing pre-tensioner harness connector, insert a thin screwdriver (1) wrapped in tape (3) into the notch. Lift the locking tab to unlock (2), then remove the connector.
- Install the pre-tensioner harness connector with the locking tab raised, then push the locking tab into the connector to lock (4).

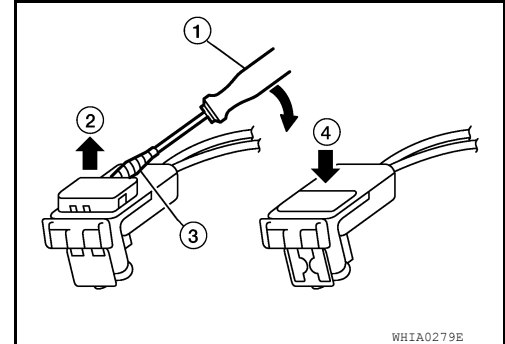

Installation

Installation is in the reverse order of removal.

- Install the seat belt retractor and belt assembly bolt upper first.
- Make sure that seat belt height adjuster is locked in the lowest position during installation.

FRONT SEAT BELT BUCKLE

Removal

1. Remove the front seat. Refer to [SE-63. "Removal and Installation - Front Seat Assembly"](#).
2. Remove the seat cushion. Refer to [SE-93. "Disassembly and Assembly"](#).
3. Disconnect the harness connector from seat belt buckle pre-tensioner.

CAUTION:

- For removing pre-tensioner harness connector, insert a thin screwdriver (1) wrapped in tape (3) into the notch. Lift the locking tab to unlock (2), then remove the connector.
- Install the pre-tensioner harness connector with the locking tab raised, then push the locking tab into the connector to lock (4).

4. Remove screw and seat cushion inner finisher.

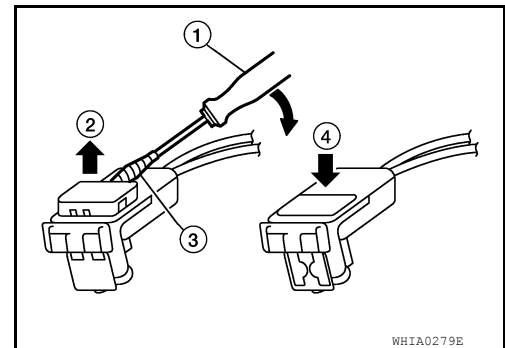

5. Remove the seat belt buckle anchor bolt and the seat belt buckle.

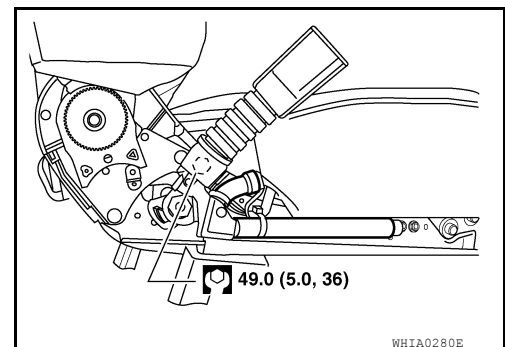

SEAT BELTS

< REMOVAL AND INSTALLATION >

Installation

Installation is in the reverse order of removal.

CAUTION:

- Front passenger seat is equipped with Occupant Classification System sensor and control module. Do not disassemble front passenger seat cushion assembly or remove trim, this will affect the Occupant Classification System calibration.
- On the passenger seat during installation, the wire harness clips must be installed in the holes they were originally in. Do not add additional clips.

Removal and Installation of Second Row Seat Belt

INFOID:000000008632228

SEC. 869

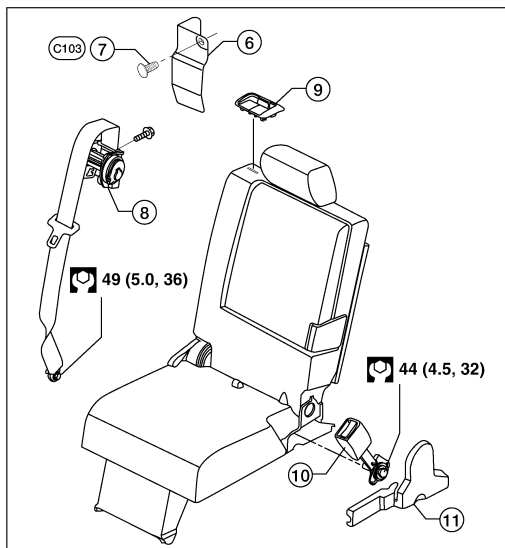
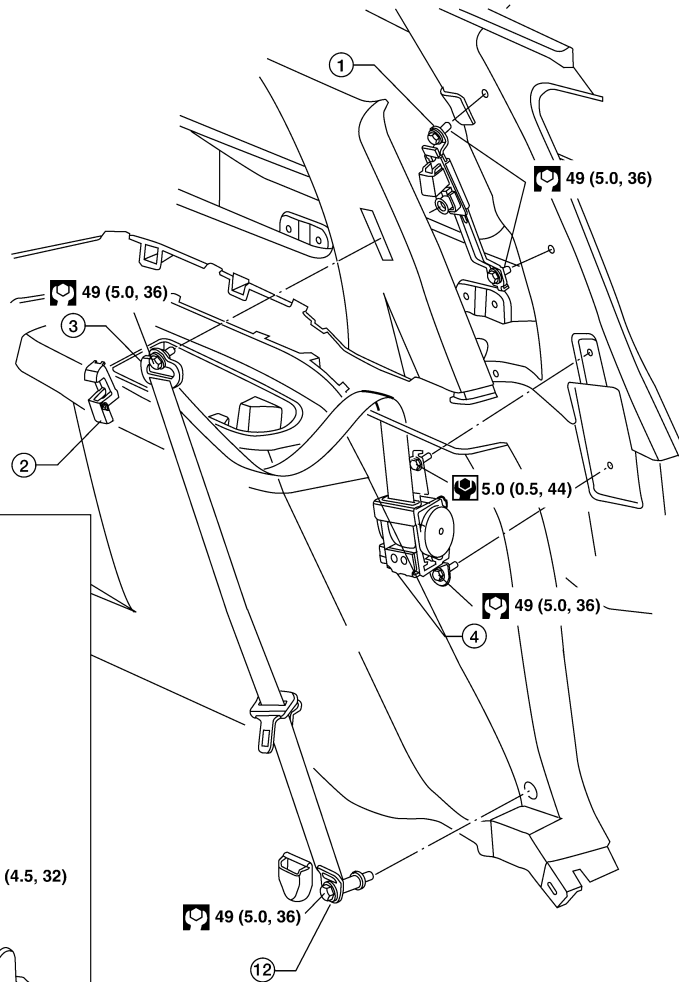
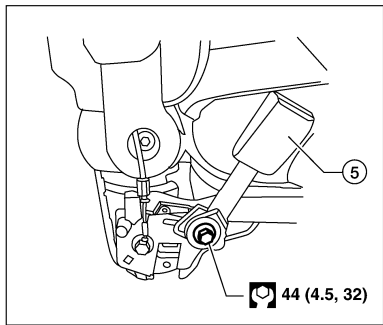

- | | | |
|---|---|------------------------------|
| 1. Seat belt height adjuster assembly | 2. D-ring anchor bolt cover | 3. D-ring anchor |
| 4. Seat belt retractor and belt assembly (RH) | 5. Seat belt buckle (RH) | 6. Seat belt retractor cover |
| 7. Push pin C103 | 8. Seat belt retractor and belt assembly (center) | 9. Seat belt bezel |
| 10. Seat belt buckle (center) | 11. Seat cushion finisher | 12. Seat belt lower anchor |

AWHIA0221GB

A
B
C
D
E
F
G
SB
I
J
K
L
M
N
O
P

SEAT BELTS

< REMOVAL AND INSTALLATION >

SECOND ROW SEAT BELT RETRACTOR (LH/RH)

Removal

1. Remove seat belt lower anchor cover and seat belt lower anchor bolt.
2. Remove the D-ring anchor bolt cover and D-ring anchor bolt.
3. Remove the lower luggage area trim. Refer to [INT-18, "Removal and Installation"](#).
4. Remove the seat belt guide bolt.
5. Remove seat belt retractor anchor bolt and the seat belt assembly.

Installation

Installation is in the reverse order of removal.

NOTE:

Make sure that seat belt height adjuster is locked in the lowest position during installation.

SECOND ROW SEAT BELT RETRACTOR (CENTER)

Removal

1. Remove the seat belt anchor bolt.
2. Remove the seat belt bezel.
3. Remove the seatback assembly. Refer to [SE-96, "Exploded View"](#).
4. Remove the seat belt retractor cover.
5. Remove the anchor bolt and remove the seat belt retractor and belt assembly.

Installation

Installation is in the reverse order of removal.

SECOND ROW SEAT BELT BUCKLE (LH/RH)

Removal

1. Remove the seat cushion finisher. Refer to [SE-96, "Exploded View"](#).
2. Remove the anchor bolt and the seat belt buckle.

Installation

Installation is in the reverse order of removal.

SECOND ROW SEAT BELT BUCKLE (CENTER)

Removal

1. Remove the rear seat (center). Refer to [SE-72, "Removal and Installation - Center Seat"](#).
2. Remove the seat cushion inner finisher. Refer to [SE-96, "Exploded View"](#).
3. Remove the anchor bolt and the seat belt buckle.

Installation

Installation is in the reverse order of removal.

Removal and Installation of Third Row Seat Belt

INFOID:000000008632229

THIRD ROW SEAT BELT RETRACTOR (LH/RH)

SEAT BELTS

< REMOVAL AND INSTALLATION >

SEC.869

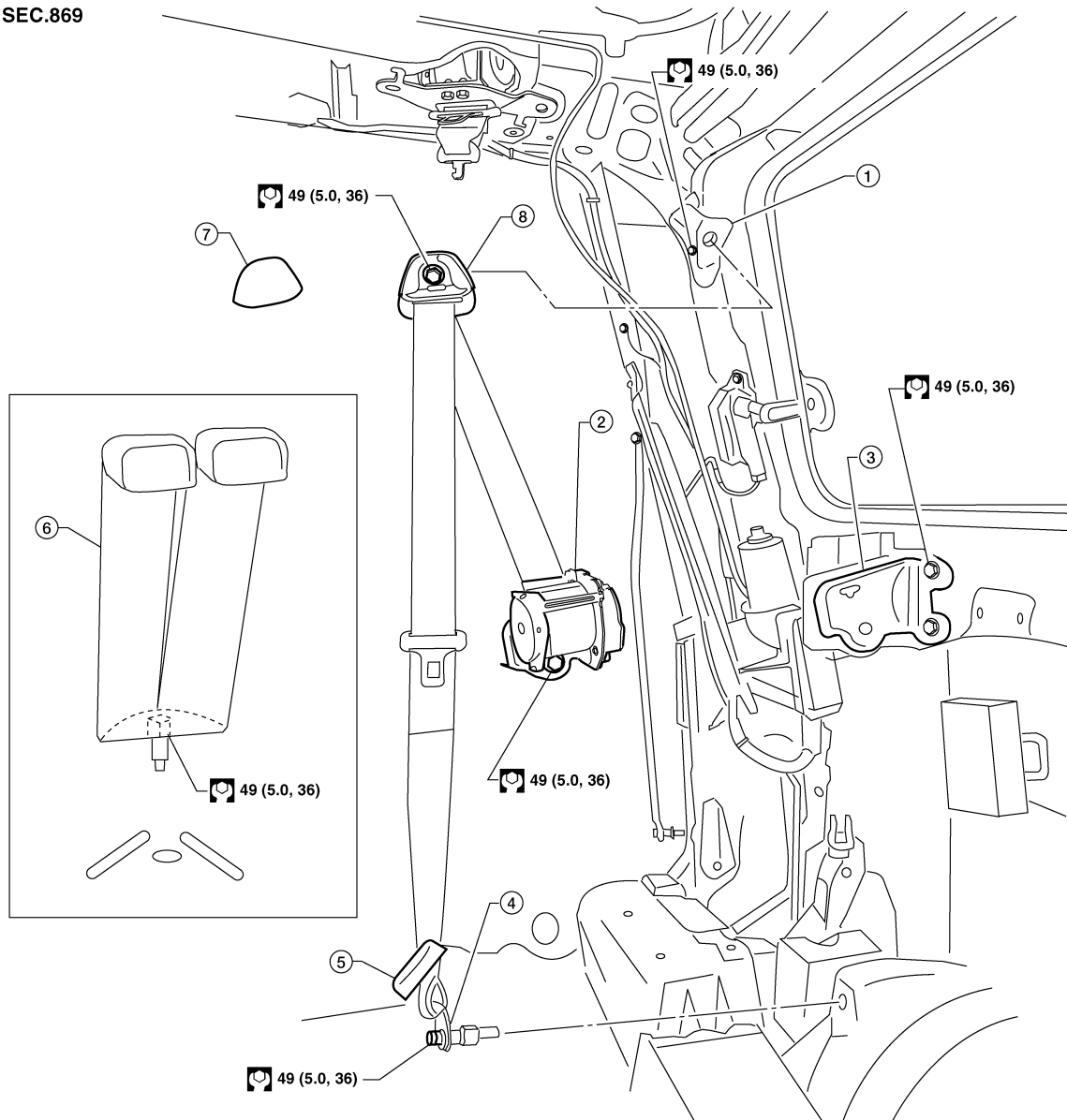

WHIA0283E

- | | | |
|-----------------------------|--|--|
| 1. D-ring anchor bracket | 2. Seat belt retractor and belt assembly | 3. Seat belt retractor and belt assembly bracket |
| 4. Seat belt lower anchor | 5. Seat belt lower anchor bolt cover | 6. Seat belt buckles |
| 7. D-ring anchor bolt cover | 8. D-ring anchor | |

Removal

1. Remove the D-ring anchor bolt cover and D-ring anchor bolt.
2. Remove the seat belt lower anchor bolt cover and seat belt lower anchor bolt.
3. Remove the upper and lower luggage side finishers. Refer to [INT-24, "Removal and Installation"](#).
4. Remove the seat belt retractor and belt assembly bolt and the seat belt retractor.

Installation

Installation is in the reverse order of removal.

- Seat belt lower anchor base should be flat to the floor during installation and not on the anti-rotation bead.

THIRD ROW SEAT BELT RETRACTOR (CENTER)

SEAT BELTS

< REMOVAL AND INSTALLATION >

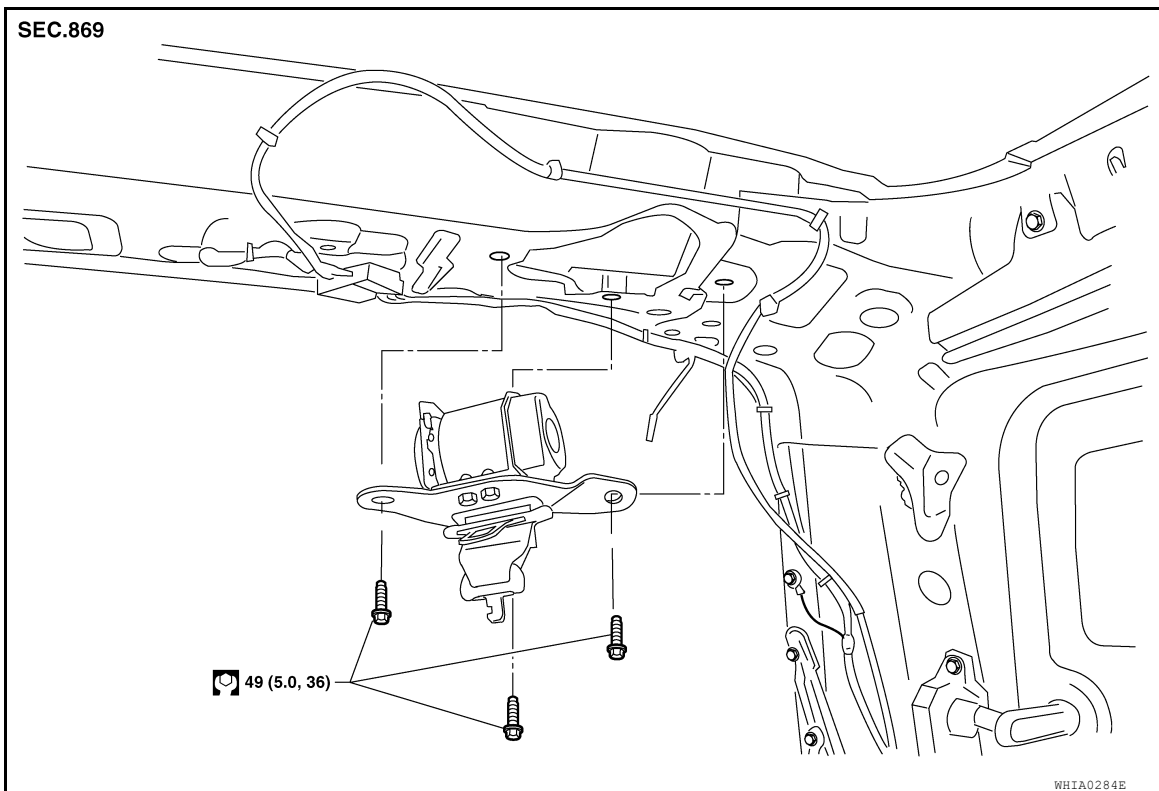

Removal

1. Remove the rear roof finisher. Refer to [INT-21, "Removal and Installation"](#).
2. Lower the rear portion of the headlining. Refer to [INT-21, "Removal and Installation"](#).
3. Remove the center seat belt retractor bolts and then remove the center seat belt retractor.

Installation

Installation is in the reverse order of removal.

THIRD ROW SEAT BELT BUCKLE

Removal

1. Place third row seatback (LH/RH) in the folded position.
2. Remove luggage floor board assembly. Refer to [INT-24, "Removal and Installation"](#).
3. Position the storage box aside as necessary to access the seat belt buckle nut (center and RH buckles) or bolt (LH buckle).
4. Remove seat belt buckle nut or bolt as applicable.

Seat belt buckle nut or bolt : 49 N·m (5.0 kg-m, 36 ft-lb)

5. Remove the seat cushion side facing push pin and release elastic band from seat belt buckle. Repeat for opposite seat.
6. Partially lift seatback upright, then remove seat belt buckle (2) from between hinge cover (1) and seat cushion side facing (3). Repeat for LH seat.

↔: Vehicle front

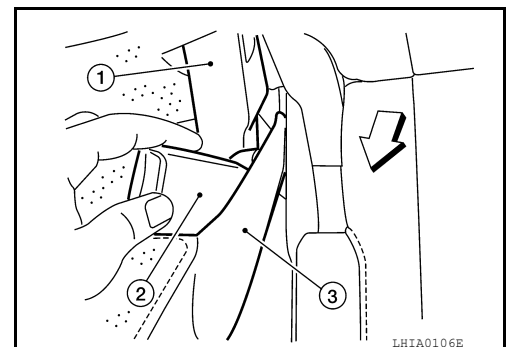

SEAT BELTS

< REMOVAL AND INSTALLATION >

Installation

Installation is in the reverse order of removal.

- After installation is complete, raise and lock both seats in the full upright position to check for abnormal noises or binding.

A

B

C

D

E

F

G

SB

I

J

K

L

M

N

O

P

LATCH (LOWER ANCHORS AND TETHER FOR CHILDREN) SYSTEM

< REMOVAL AND INSTALLATION >

LATCH (LOWER ANCHORS AND TETHER FOR CHILDREN) SYSTEM

Removal and Installation

INFOID:000000008632231

The LATCH (Lower Anchors and Tether for Children) system components are part of the vehicle structure, and are not serviceable.

TOP TETHER STRAP CHILD RESTRAINT

< REMOVAL AND INSTALLATION >

TOP TETHER STRAP CHILD RESTRAINT

Removal and Installation

INFOID:000000008632232

REMOVAL

1. Remove luggage room rear lower finisher. Refer to [INT-24. "Removal and Installation"](#).
2. Remove the tether anchor bolt and the tether anchor.
⇐: Front

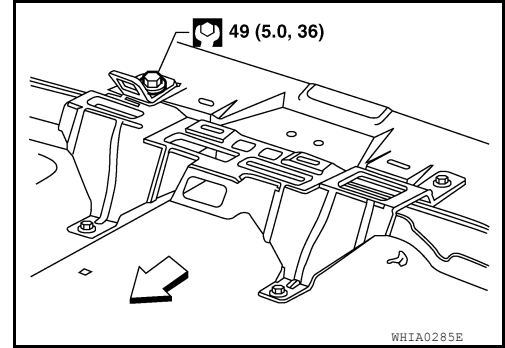

INSTALLATION

Installation is in the reverse order of removal.

A
B
C
D
E
F
G
SB
I
J
K
L
M
N
O
P