

SECTION **ST**
STEERING SYSTEM

A
 B
 C
 D
 E
 F
ST
 H
 I
 J
 K
 L
 M
 N
 O
 P

CONTENTS

PRECAUTION	3	POWER STEERING OIL PUMP	15
PRECAUTIONS	3	On-Vehicle Inspection and Service	15
Precaution for Supplemental Restraint System (SRS) "AIR BAG" and "SEAT BELT PRE-TENSIONER"	3	STEERING WHEEL	16
Precaution Necessary for Steering Wheel Rotation After Battery Disconnect	3	On-Vehicle Inspection and Service	16
Precaution for Steering System	4	UNIT REMOVAL AND INSTALLATION	18
PREPARATION	5	HYDRAULIC LINE	18
PREPARATION	5	Removal and Installation	18
Special Service Tool	5	POWER STEERING OIL PUMP	20
Commercial Service Tool	6	Removal and Installation	20
SYSTEM DESCRIPTION	7	POWER STEERING GEAR AND LINKAGE	22
HEATED STEERING WHEEL	7	Removal and Installation	22
System Diagram	7	STEERING COLUMN	24
System Description	7	Removal and Installation	24
Component Parts Location	7	STEERING WHEEL	28
Component Description	8	Removal and Installation	28
SYMPTOM DIAGNOSIS	9	UNIT DISASSEMBLY AND ASSEMBLY ...	29
NOISE, VIBRATION, AND HARSHNESS (NVH) TROUBLESHOOTING	9	POWER STEERING OIL PUMP	29
NVH Troubleshooting Chart	9	Disassembly and Assembly	29
WIRING DIAGRAM	10	POWER STEERING GEAR AND LINKAGE	30
HEATED STEERING WHEEL	10	Disassembly and Assembly	30
Wiring Diagram	10	STEERING COLUMN	33
PERIODIC MAINTENANCE	13	Disassembly and Assembly	33
POWER STEERING FLUID	13	SERVICE DATA AND SPECIFICATIONS (SDS)	35
Checking Fluid Level	13	SERVICE DATA AND SPECIFICATIONS (SDS)	35
Checking Fluid Leakage	13	Steering Wheel	35
Air Bleeding Hydraulic System	13	Steering Column	35
REMOVAL AND INSTALLATION	15	Steering Outer Socket and Inner Socket	36
		Tie-rod	36

Steering Gear	37	Steering Fluid	37
Oil Pump	37		

PRECAUTIONS

< PRECAUTION >

PRECAUTION

PRECAUTIONS

Precaution for Supplemental Restraint System (SRS) "AIR BAG" and "SEAT BELT PRE-TENSIONER"

INFOID:000000008929701

The Supplemental Restraint System such as "AIR BAG" and "SEAT BELT PRE-TENSIONER", used along with a front seat belt, helps to reduce the risk or severity of injury to the driver and front passenger for certain types of collision. This system includes seat belt switch inputs and dual stage front air bag modules. The SRS system uses the seat belt switches to determine the front air bag deployment, and may only deploy one front air bag, depending on the severity of a collision and whether the front occupants are belted or unbelted. Information necessary to service the system safely is included in the SR and SB section of this Service Manual.

WARNING:

- To avoid rendering the SRS inoperative, which could increase the risk of personal injury or death in the event of a collision which would result in air bag inflation, all maintenance must be performed by an authorized NISSAN/INFINITI dealer.
- Improper maintenance, including incorrect removal and installation of the SRS, can lead to personal injury caused by unintentional activation of the system. For removal of Spiral Cable and Air Bag Module, see the SR section.
- Do not use electrical test equipment on any circuit related to the SRS unless instructed to in this Service Manual. SRS wiring harnesses can be identified by yellow and/or orange harnesses or harness connectors.

PRECAUTIONS WHEN USING POWER TOOLS (AIR OR ELECTRIC) AND HAMMERS

WARNING:

- When working near the Airbag Diagnosis Sensor Unit or other Airbag System sensors with the Ignition ON or engine running, DO NOT use air or electric power tools or strike near the sensor(s) with a hammer. Heavy vibration could activate the sensor(s) and deploy the air bag(s), possibly causing serious injury.
- When using air or electric power tools or hammers, always switch the Ignition OFF, disconnect the battery and wait at least 3 minutes before performing any service.

Precaution Necessary for Steering Wheel Rotation After Battery Disconnect

INFOID:000000008632234

NOTE:

- This Procedure is applied only to models with Intelligent Key system and NATS (NISSAN ANTI-THEFT SYSTEM).
- Remove and install all control units after disconnecting both battery cables with the ignition knob in the "LOCK" position.
- Always use CONSULT to perform self-diagnosis as a part of each function inspection after finishing work. If DTC is detected, perform trouble diagnosis according to self-diagnostic results.

For models equipped with the Intelligent Key system and NATS, an electrically controlled steering lock mechanism is adopted on the key cylinder.

For this reason, if the battery is disconnected or if the battery is discharged, the steering wheel will lock and steering wheel rotation will become impossible.

If steering wheel rotation is required when battery power is interrupted, follow the procedure below before starting the repair operation.

OPERATION PROCEDURE

1. Connect both battery cables.

NOTE:

Supply power using jumper cables if battery is discharged.

2. Use the Intelligent Key or mechanical key to turn the ignition switch to the "ACC" position. At this time, the steering lock will be released.
3. Disconnect both battery cables. The steering lock will remain released and the steering wheel can be rotated.
4. Perform the necessary repair operation.

PRECAUTIONS

< PRECAUTION >

5. When the repair work is completed, return the ignition switch to the "LOCK" position before connecting the battery cables. (At this time, the steering lock mechanism will engage.)
6. Perform a self-diagnosis check of all control units using CONSULT.

Precaution for Steering System

INFOID:000000008632235

- Before disassembly, thoroughly clean the outside of the unit.
- Disassembly should be done in a clean work area. It is important to prevent the internal parts from becoming contaminated by dirt or other foreign matter.
- For easier and proper assembly, place disassembled parts in order on a parts rack.
- Use nylon cloth or paper towels to clean the parts; common shop rags can leave lint that might interfere with their operation.
- Before inspection or reassembly, carefully clean all parts with a general purpose, non-flammable solvent.
- Before assembly, apply a coat of recommended Genuine NISSAN PSF or equivalent to hydraulic parts. Petroleum jelly may be applied to O-rings and seals. Do not use any grease.
- Replace all gaskets, seals and O-rings. Avoid damaging O-rings, seals and gaskets during installation. Perform functional tests whenever designated.

PREPARATION

< PREPARATION >

PREPARATION

PREPARATION

Special Service Tool

INFOID:0000000008632236

The actual shapes of Kent-Moore tools may differ from those of special service tools illustrated here.

Tool number (Kent-Moore No.) Tool name	Description
ST3127 S000 (See J-25765-A) Preload gauge 1. GG9103000 (J-25765-A) Torque wrench 2. HT62940000 (—) Socket adapter 3. HT62900000 (—) Socket adapter	Inspecting of pinion rotating torque and rotational torque for ball joint
1. KV48105300-4 and 5295262U10 (—) Connector A and O-ring 2. KV48105300-3 and 5295262U00 (—) Eye-bolt and O-ring 3. KV48103500 (J-26357 and J-26357-10) Pressure gauge and shut-off valve 4. KV48105300-1 and 5295262U00 (—) Connector B and O-ring 5. KV48105300-2 (—) Nut	Measuring oil pump relief pressure
ST27180001 (J-25726-A) Steering wheel puller	Removing steering wheel
KV40107300 (—)	Crimping boot bands
— (J-44372) Spring gauge	Measuring steering wheel turning force

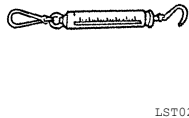
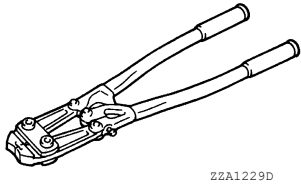
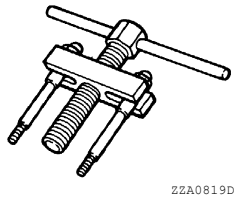
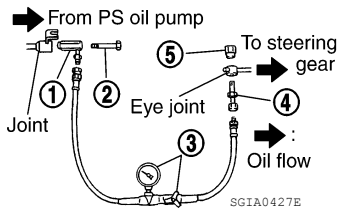
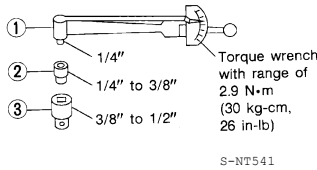

PREPARATION

< PREPARATION >

Commercial Service Tool

INFOID:000000008632237

Tool name	Description
<p data-bbox="162 289 267 315">Power tool</p>  <p data-bbox="828 504 901 525">PIIB1407E</p>	<p data-bbox="1015 289 1347 315">Loosening nuts, screws and bolts</p>

HEATED STEERING WHEEL

< SYSTEM DESCRIPTION >

SYSTEM DESCRIPTION

HEATED STEERING WHEEL

System Diagram

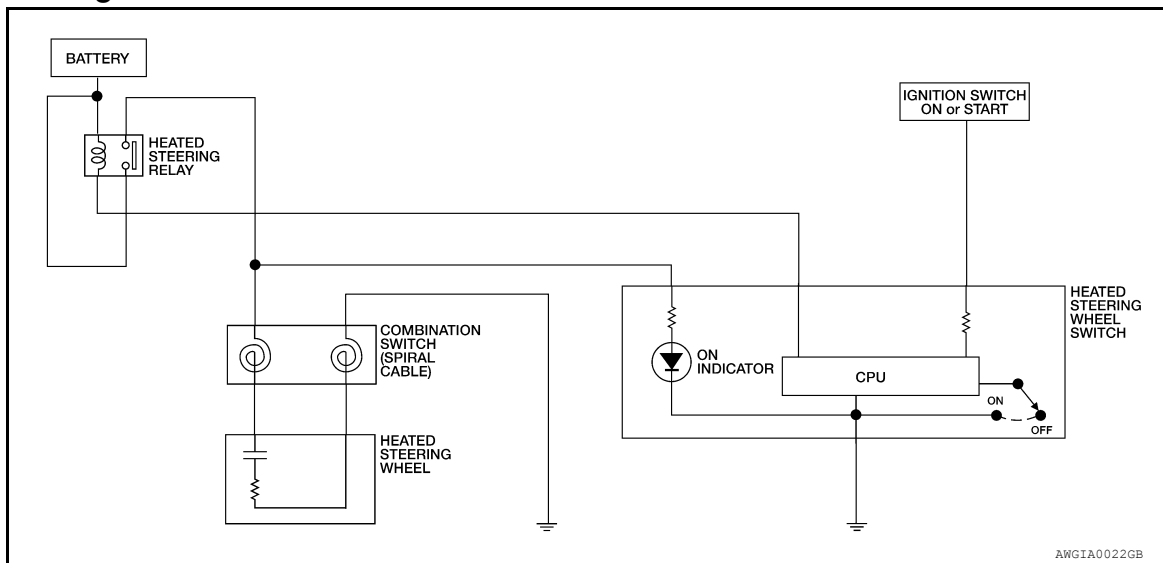

System Description

INFOID:000000008632239

The heated steering wheel switch controls the heated steering relay. When the switch is turned on, the relay is energized and the heated steering system will operate. The heated steering system will turn off when the steering wheel temperature reaches approximately 86° F (30° C). Heated steering system operation can also be cancelled by pressing the heated steering wheel switch again.

NOTE:

If the surface temperature of the steering wheel is below 68° F (20° C), the system will heat the steering wheel and cycle off and on to maintain a temperature above 68° F (20° C). The indicator light will remain on as long as the system is on. Push the switch again to turn the heated steering wheel system off manually. The indicator light will go off.

Component Parts Location

INFOID:000000008632240

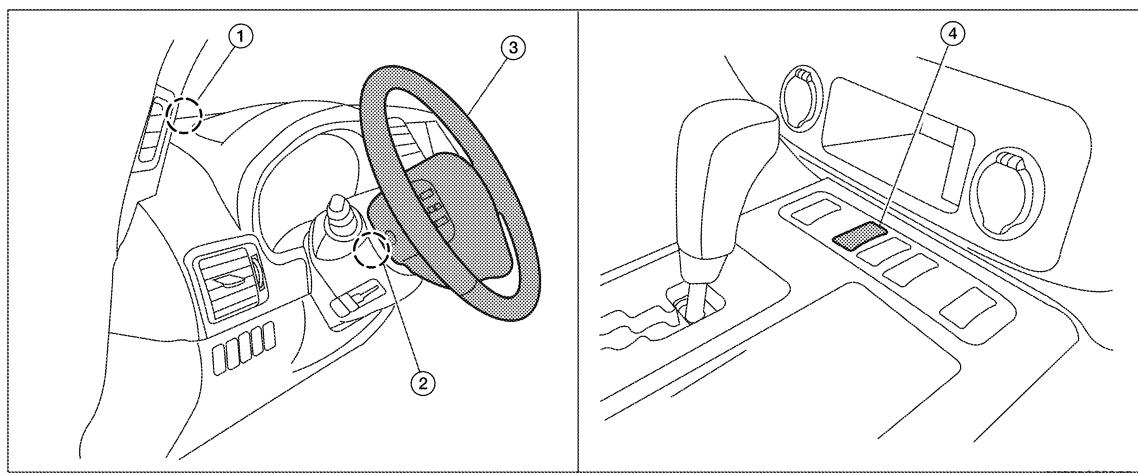

1. Heated steering relay M71
2. Combination switch (spiral cable) M52
3. Heated steering wheel M114
4. Heated steering wheel switch M260

HEATED STEERING WHEEL

< SYSTEM DESCRIPTION >

Component Description

INFOID:000000008632241

Part name	Description
Heated steering wheel switch	<ul style="list-style-type: none">• Controls the heated steering relay and operates the heated steering system.• Turns the indicator lamp ON when the system is activated.
Heated steering relay	<ul style="list-style-type: none">• Operates the heated steering system with the control signal from the heated steering wheel switch.
Heated steering wheel	<ul style="list-style-type: none">• Heats the heating element with the power supplied from the heated steering relay.

NOISE, VIBRATION, AND HARSHNESS (NVH) TROUBLESHOOTING

< SYMPTOM DIAGNOSIS >

SYMPTOM DIAGNOSIS

NOISE, VIBRATION, AND HARSHNESS (NVH) TROUBLESHOOTING

NVH Troubleshooting Chart

INFOID:000000008632242

Use chart below to help you find the cause of the symptom. If necessary, repair or replace these parts.

Reference page		Possible cause and suspected parts		Symptom				
Reference page		Possible cause and suspected parts		Noise	Shake	Vibration	Shimmy	Shudder
	ST-13	Fluid level		x				
	ST-13	Air in hydraulic system		x				
	ST-36	Outer socket ball joint swinging force		x				
	ST-36	Outer socket ball joint rotating torque		x				
	ST-36	Outer socket ball joint end play		x				
	ST-13	Steering fluid leakage		x				
	ST-16	Steering wheel play		x				
	ST-16	Steering gear rack sliding force		x				
	EM-14, "Checking Drive Belts"	Drive belt looseness		x				
	ST-16	Improper steering wheel			x		x	
	ST-24	Improper installation or looseness of tilt lock lever			x		x	
	ST-30	Mounting rubber deterioration			x		x	
	ST-24	Steering column deformation or damage				x		
	ST-33	Improper installation or looseness of steering column					x	
	ST-22	Steering linkage looseness					x	
	DLN-183, "NVH Troubleshooting Chart" (2F1310), DLN-193, "NVH Troubleshooting Chart" (2S1410)	PROPELLER SHAFT			x			
	DLN-207, "NVH Troubleshooting Chart"	FRONT FINAL DRIVE			x			
	FAX-5, "NVH Troubleshooting Chart"	WHEEL HUB			x		x	
	FSU-5, "NVH Troubleshooting Chart"	SUSPENSION			x		x	
	WT-45, "NVH Troubleshooting Chart"	TIRES			x		x	
	WT-45, "NVH Troubleshooting Chart"	ROAD WHEEL			x		x	
	FAX-5, "NVH Troubleshooting Chart"	DRIVE SHAFT				x		
	BR-6, "NVH Troubleshooting Chart"	BRAKES						x

x: Applicable

A
B
C
D
E
F
ST
H
I
J
K
L
M
N
O
P

HEATED STEERING WHEEL

< WIRING DIAGRAM >

WIRING DIAGRAM

HEATED STEERING WHEEL

Wiring Diagram

INFOID:000000008632243

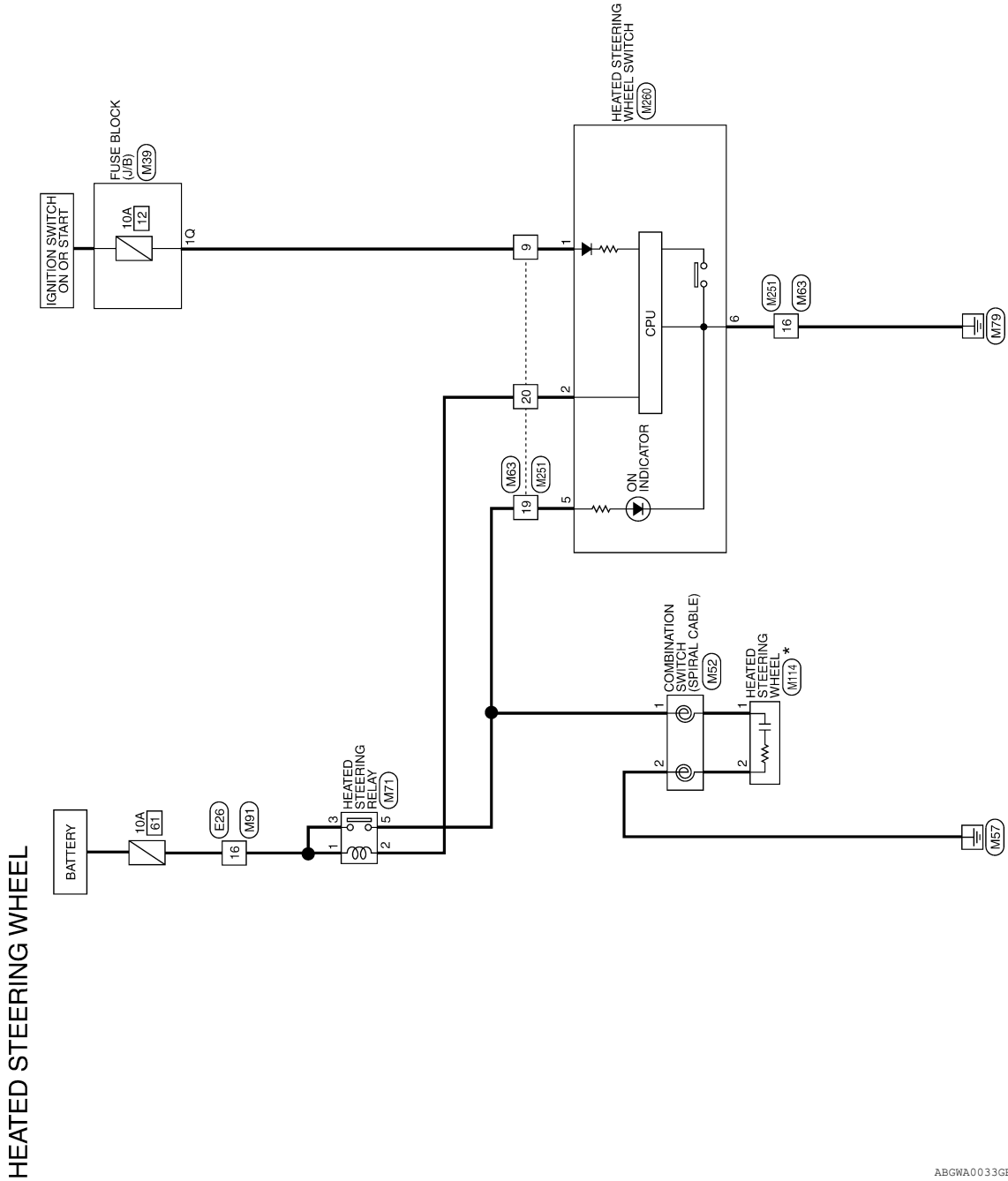

* : THIS CONNECTOR IS NOT SHOWN IN "HARNES LAYOUT" OF PG SECTION.

ABGWA0033GB

HEATED STEERING WHEEL

< WIRING DIAGRAM >

HEATED STEERING WHEEL CONNECTORS

Connector No.	M39
Connector Name	FUSE BLOCK (J/B)
Connector Color	WHITE

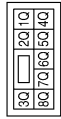

Terminal No.	Color of Wire	Signal Name
1Q	G/R	-

Connector No.	M52
Connector Name	COMBINATION SWITCH
Connector Color	WHITE



Terminal No.	Color of Wire	Signal Name
1	BR	-
2	B	-

Connector No.	M63
Connector Name	WIRE TO WIRE
Connector Color	BROWN

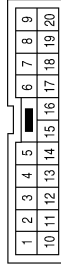

Terminal No.	Color of Wire	Signal Name
9	G/R	-
16	B	-
19	BR	-
20	B/R	-

Connector No.	M71
Connector Name	HEATED STEERING RELAY
Connector Color	BLUE



Terminal No.	Color of Wire	Signal Name
1	B/W	-
2	B/R	-
3	B/W	-
5	BR	-

Connector No.	M91
Connector Name	WIRE TO WIRE
Connector Color	WHITE

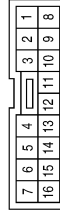

Terminal No.	Color of Wire	Signal Name
16	B/W	-

Connector No.	M114
Connector Name	HEATED STEERING WHEEL
Connector Color	WHITE



Terminal No.	Color of Wire	Signal Name
1	Y	-
2	L	-

ABGIA0024GB

A
B
C
D
E
F
ST
H
I
J
K
L
M
N
O
P

HEATED STEERING WHEEL

< WIRING DIAGRAM >

Connector No.	E26
Connector Name	WIRE TO WIRE
Connector Color	WHITE

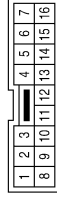

Terminal No.	Color of Wire	Signal Name
16	BW	-

Connector No.	M260
Connector Name	HEATED STEERING WHEEL SWITCH
Connector Color	WHITE

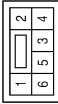

Terminal No.	Color of Wire	Signal Name
1	G/R	-
2	B/R	-
5	BR	-
6	B	-

Connector No.	M251
Connector Name	WIRE TO WIRE
Connector Color	BROWN

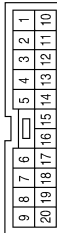

Terminal No.	Color of Wire	Signal Name
9	G/R	-
16	B	-
19	BR	-
20	B/R	-

ABGIA0025GB

POWER STEERING FLUID

< PERIODIC MAINTENANCE >

PERIODIC MAINTENANCE

POWER STEERING FLUID

Checking Fluid Level

INFOID:000000008632244

Check power steering fluid level with engine off, referring to the scale on reservoir tank.

Use HOT range for fluid temperatures of 50° – 80°C (122° – 176°F).
Use COLD range for fluid temperatures of 0° – 30°C (32° – 86°F).

CAUTION:

- Do not overfill.
- Do not reuse any power steering fluid.
- Use the recommended power steering fluid or equivalent. Refer to [MA-17, "FOR USA AND CANADA : Fluids and Lubricants"](#).

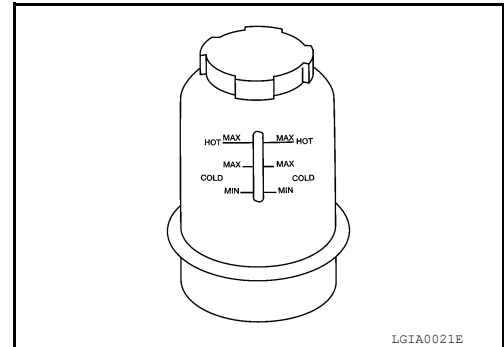

Checking Fluid Leakage

INFOID:000000008632245

Check the hydraulic piping lines for improper attachment and for leaks, cracks, damage, loose connections, chafing or deterioration.

1. Run engine until fluid temperature reaches 50° – 80°C (122° – 176°F) in reservoir tank. Keep engine speed idle.
2. Turn steering wheel right-to-left several times.
3. Hold steering wheel at each "lock" position for five seconds to check fluid leakage.

CAUTION:

Do not hold steering wheel in a locked position for more than 10 seconds. (There is the possibility that oil pump may be damaged.)

4. If fluid leakage at connections is noticed, then loosen flare nut and then retighten. Do not over tighten connector as this can damage O-ring, washer and connector.
5. If fluid leakage from oil pump is noticed, check oil pump. Refer to [ST-15](#).
6. Check steering gear boots for accumulation of fluid indicating a leak from the steering gear.

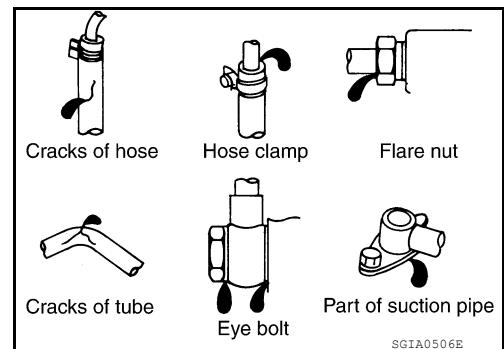

Air Bleeding Hydraulic System

INFOID:000000008632246

CAUTION:

Incomplete air bleeding causes the following. When this happens, bleed air again.

- Air bubbles in reservoir tank.
- Clicking noise in oil pump.
- Excessive buzzing in oil pump.

NOTE:

When vehicle is stationary or while steering wheel is being turned slowly, some noise may be heard from oil pump or gear. This noise is normal and does not affect any system.

1. Stop engine, and then turn steering wheel fully to right and left several times.
CAUTION:
Do not allow steering fluid reservoir tank to go below the MIN level line. Check tank frequently and add fluid as needed.
2. Run engine at idle speed. Turn steering wheel fully right and then fully left, hold for about three seconds. Then check for fluid leakage.
3. Repeat step 2 several times at about three second intervals.
CAUTION:
Do not hold steering wheel in the locked position for more than 10 seconds. (There is the possibility that oil pump may be damaged.)
4. Check for air bubbles or cloudy fluid.

POWER STEERING FLUID

< PERIODIC MAINTENANCE >

5. If air bubbles or cloudiness still exists, stop engine, perform steps 2 and 3 again until air bubbles or cloudiness does not exist.
6. Stop engine, check fluid level.

POWER STEERING OIL PUMP

< REMOVAL AND INSTALLATION >

REMOVAL AND INSTALLATION

POWER STEERING OIL PUMP

On-Vehicle Inspection and Service

INFOID:000000008632247

CHECKING RELIEF OIL PRESSURE

CAUTION:

Before starting work, confirm belt tension is correct. Refer to [EM-14, "Checking Drive Belts"](#).

1. Connect Tool between oil pump discharge connector and high pressure hose and then bleed air from the hydraulic circuit.

Tool number:		
Pressure gauge and shut-off valve		KV48103500 (J26357 and J26357-10)
Oil pump side	Connector A and O-ring	KV48105300-4 and 5295262U10 (—)
	Eye-bolt and O-ring	KV48105300-3 and 5295262U00 (—)
High pressure piping side	Connector B and O-ring	KV48105300-1 and 5295262U00 (—)
	Nut	KV48105300-2 (—)

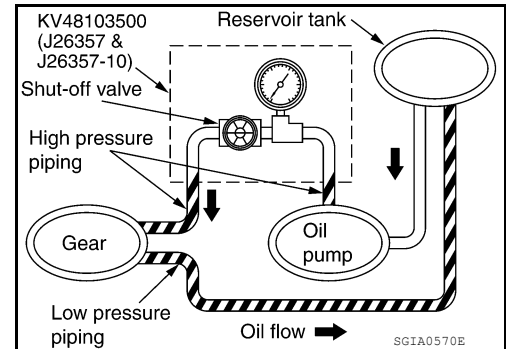

2. Start engine. Allow engine to run until tank temperature reaches 50 – 80°C (122 – 176°F).

CAUTION:

- Warm up engine with shut-off valve fully opened. If engine is started with shut-off valve closed, fluid pressure in power steering pump increases to maximum. This will raise fluid temperature excessively.
- Be careful not to contact hose with belt when engine is started.

3. With engine at idle, close shut-off valve and read the relief oil pressure.

Relief oil pressure : Refer to [ST-37, "Oil Pump"](#).

CAUTION:

Do not close shut-off valve of pressure gauge for more than 10 seconds.

4. After measurement, open shut-off valve slowly.
 - If relief oil pressure is outside the specification, repair or replace oil pump. Refer to [ST-29, "Disassembly and Assembly"](#).
5. After inspection, disconnect oil pressure gauge and oil pressure gauge adapter from hydraulic circuit, connect oil pump discharge connector and high pressure hose. Add fluid and bleed air from hydraulic circuit thoroughly. Refer to [ST-13, "Air Bleeding Hydraulic System"](#).

STEERING WHEEL

< REMOVAL AND INSTALLATION >

STEERING WHEEL

On-Vehicle Inspection and Service

INFOID:000000008632248

CHECKING CONDITION OF INSTALLATION

- Check installation condition of steering gear assembly, front suspension, axle and steering column.
- Check if movement exists when steering wheel is moved up and down, to the left and right and to the axial direction.

End play of the axial direction for steering wheel : Refer to [ST-35, "Steering Wheel"](#).

- Check if the nuts for steering gear assembly are loose. Refer to [ST-22](#).

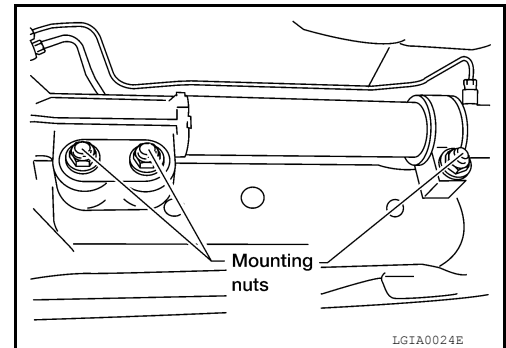

CHECKING STEERING WHEEL PLAY

1. Turn tires straight ahead, start engine, then turn steering wheel to the left and right lightly, and measure steering wheel movement on the outer circumference when steering wheel is turned up to the point where tires start moving.

Steering wheel play on the outer circumference : Refer to [ST-35, "Steering Wheel"](#).

CHECKING NEUTRAL POSITION ON STEERING WHEEL

- Check neutral position on steering wheel after confirming that front wheel alignment is correct. Refer to [FSU-6, "Front Wheel Alignment"](#).
1. Turn tires straight ahead, check if steering wheel is in the neutral position.
 2. If it is not in the neutral position, remove steering wheel and reinstall it correctly.
 3. If the neutral position cannot be attained by repositioning the steering wheel two teeth or less on steering stem, loosen tie-rod lock nuts of steering outer sockets, then adjust tie-rods by the same amount in the opposite direction.

CHECKING STEERING WHEEL TURNING FORCE

1. Park vehicle on a level, dry surface and set parking brake.
2. Start engine.
3. Bring power steering fluid up to an operating temperature of approximately 60° – 80°C (140° – 176°F).
4. Make sure the tires are inflated to specified pressure. Refer to [WT-55, "Tire"](#).
5. Check steering wheel turning force using Tool when steering wheel has been turned 360° from the neutral position.

Tool number : (—) J-44372

Steering wheel turning force : Refer to [ST-35, "Steering Wheel"](#).

6. If steering wheel turning force is out of specification, inspect steering column. Refer to [ST-33, "Disassembly and Assembly"](#).
7. If steering column meets specification, repair steering gear. Refer to [ST-30, "Disassembly and Assembly"](#).

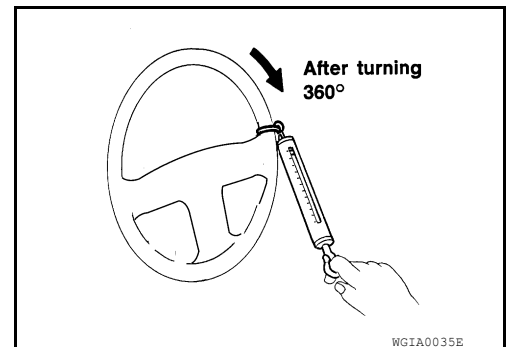

STEERING WHEEL

< REMOVAL AND INSTALLATION >

CHECKING FRONT WHEEL TURNING ANGLE

When checking front wheel turning angle, refer to [FSU-6. "Front Wheel Alignment"](#).

A

B

C

D

E

F

ST

H

I

J

K

L

M

N

O

P

HYDRAULIC LINE

< UNIT REMOVAL AND INSTALLATION >

UNIT REMOVAL AND INSTALLATION

HYDRAULIC LINE

Removal and Installation

INFOID:000000008632249

Refer to the following illustration for hydraulic line removal.

NOTE:

When removing components such as hoses, tubes/lines, etc., cap or plug openings to prevent fluid from spilling.

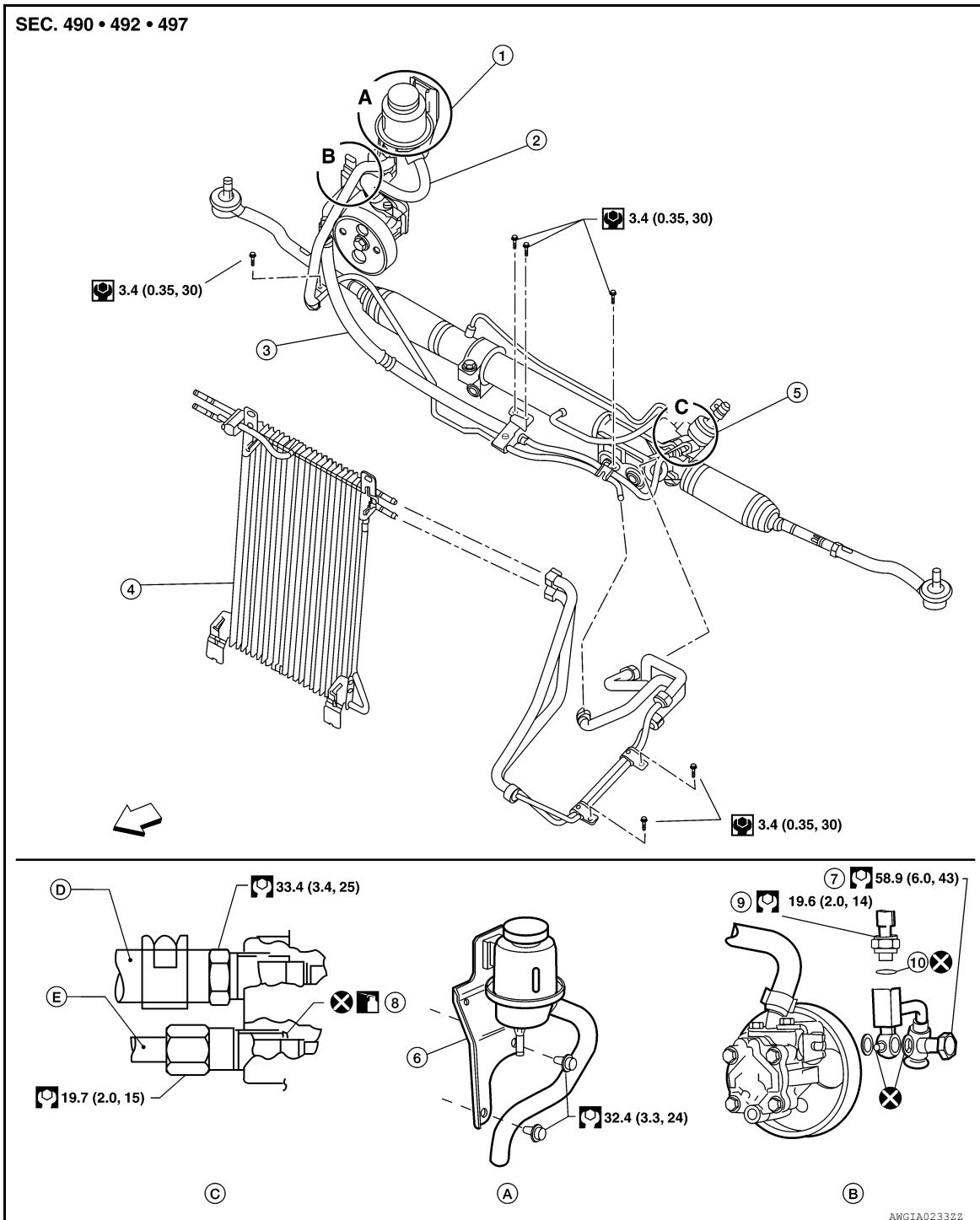

HYDRAULIC LINE

< UNIT REMOVAL AND INSTALLATION >

- | | | | |
|-----------------------------------|---------------------------|-----------------------------------|---|
| 1. Reservoir tank | 2. Suction hose | 3. High pressure hose | A |
| 4. Fluid cooler | 5. Steering gear assembly | 6. Reservoir tank bracket | B |
| 7. Eye bolt | 8. O-rings | 9. Power steering pressure sensor | B |
| 10. O-ring | A. Reservoir tank detail | B. Power steering pump detail | B |
| C. Steering gear connector detail | D. Low pressure piping | E. High pressure piping | C |
- ⇐ Front

Installation is in the reverse order of removal.

- Confirm mating marks are aligned with hose and clamp, then correct if needed.

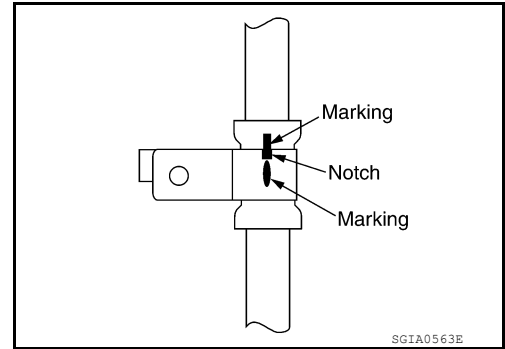

- To install eye joint, align projection (2) of eye joint with notch of power steering pump, and attach eye joint to power steering pump properly. Tighten eye bolt by hand fully, then torque to specification.

- (1) Pressure sensor
- (3) Copper sealing washers
- (4) O-ring

CAUTION:

Do not reuse O-rings or copper sealing washers.

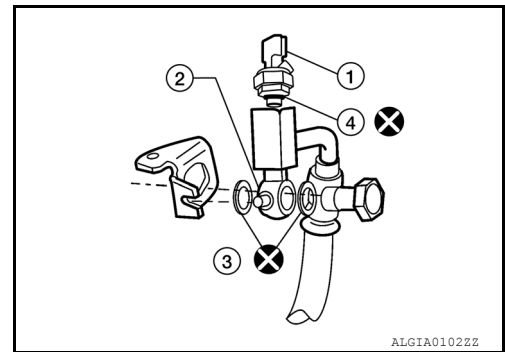

ST

H

I

J

K

L

M

N

O

P

POWER STEERING OIL PUMP

< UNIT REMOVAL AND INSTALLATION >

POWER STEERING OIL PUMP

Removal and Installation

INFOID:000000008632250

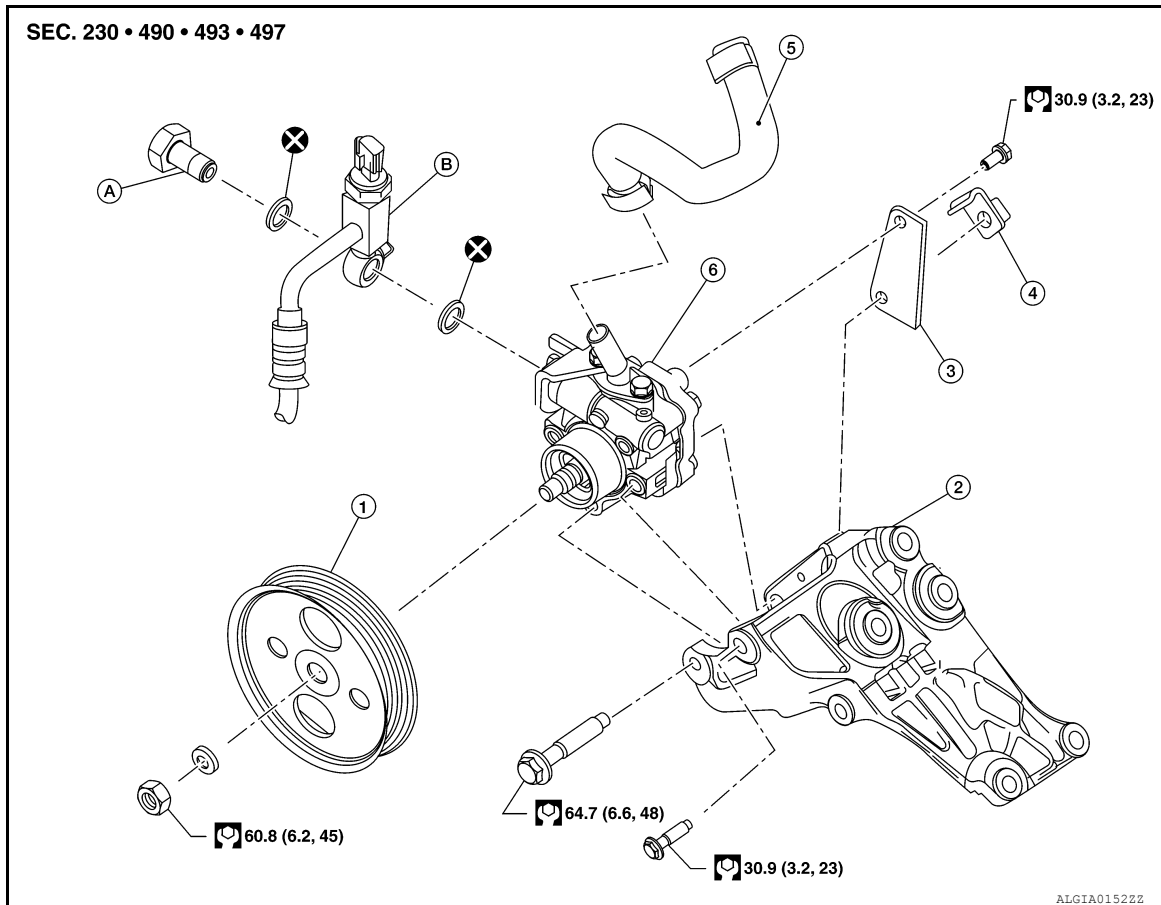

- | | | |
|---|-----------------------|------------------------|
| 1. Pulley | 2. Engine bracket | 3. Bracket |
| 4. Bracket nut | 5. Suction hose | 6. Power steering pump |
| A. Refer to ST-18, "Removal and Installation" . | B. High pressure hose | |

NOTE:

When removing components such as hoses, tubes/lines, etc., cap or plug openings to prevent fluid from spilling.

REMOVAL

1. Drain power steering fluid from reservoir tank.
2. Remove engine room cover. Refer to [EM-25, "Removal and Installation"](#).
3. Remove air duct assembly. Refer to [EM-26, "Removal and Installation"](#).
4. Remove power steering reservoir tank.
5. Remove serpentine drive belt from auto tensioner and power steering pump. Refer to [EM-14, "Removal and Installation"](#).
6. Disconnect pressure sensor electrical connector.
7. Remove high pressure and low pressure piping from power steering oil pump. Refer to [ST-18, "Removal and Installation"](#).
8. Remove the bolts and the power steering pump.

INSTALLATION

Installation is in the reverse order of removal. Refer to [ST-18, "Removal and Installation"](#) for tightening torque.
• After installation, bleed air. Refer to [ST-13, "Air Bleeding Hydraulic System"](#).

POWER STEERING OIL PUMP

< UNIT REMOVAL AND INSTALLATION >

NOTE:

Belt tension is automatic and requires no adjustment.

A

B

C

D

E

F

ST

H

I

J

K

L

M

N

O

P

POWER STEERING GEAR AND LINKAGE

< UNIT REMOVAL AND INSTALLATION >

POWER STEERING GEAR AND LINKAGE

Removal and Installation

INFOID:000000008632251

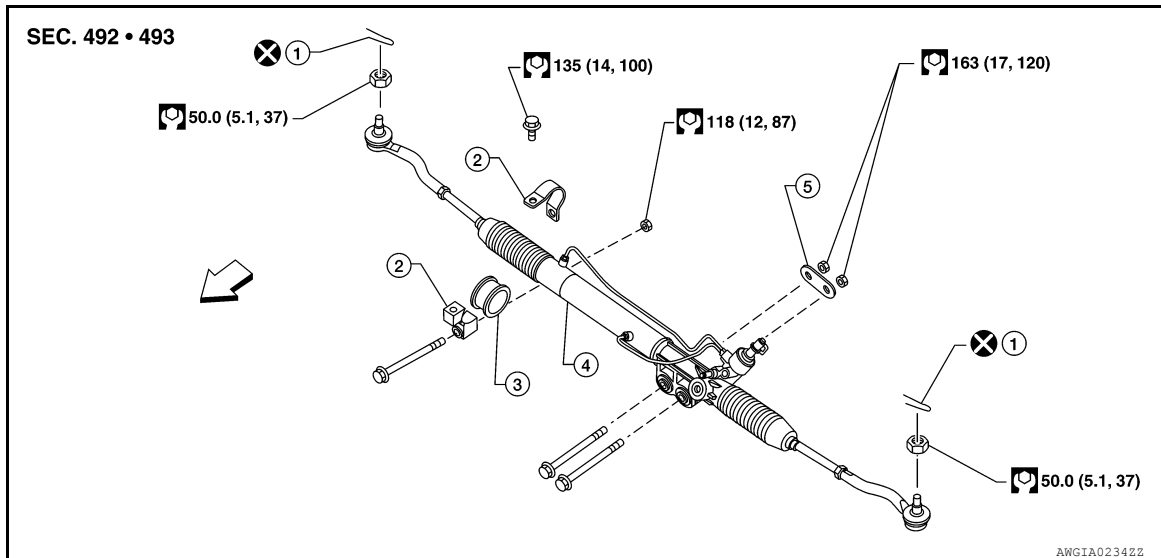

- | | | |
|---------------------------|---------------------|-----------------------|
| 1. Cotter pin | 2. Mounting bracket | 3. Mounting insulator |
| 4. Steering gear assembly | 5. Washer | ⇐ Front |

CAUTION:

Spiral cable may snap due to steering operation if steering column is separated from steering gear assembly. Therefore secure steering wheel to avoid turning.

REMOVAL

1. Turn wheels to the straight-ahead position.
2. Remove both front wheels and tires using power tool. Refer to [WT-51, "Rotation"](#).
3. Remove under cover using power tool. Refer to [EM-25, "Removal and Installation"](#).
4. On 4WD model, remove front final drive, then support drive shafts with suitable jacks. Refer to [DLN-213, "Removal and Installation"](#).
5. Remove the cotter pins at the outer sockets and discard, then loosen nuts.
6. Remove the outer sockets from the steering knuckles using suitable tool. Be careful not to damage the ball joint boots.

CAUTION:

Temporarily leave the nuts on to prevent damage to threads and to prevent Tool from coming off.

7. Remove stabilizer bar bracket bolts and reposition stabilizer bar. Refer to [FSU-13, "Removal and Installation"](#).
8. Disconnect oil piping (high pressure side and low pressure side) from steering gear assembly, remove O-ring then drain fluid from piping.

CAUTION:

Do not reuse O-ring.

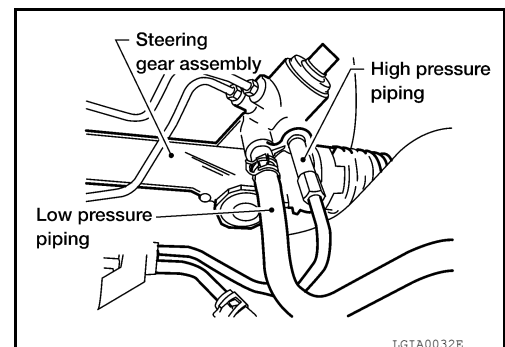

POWER STEERING GEAR AND LINKAGE

< UNIT REMOVAL AND INSTALLATION >

9. Remove lower joint bolt of lower joint shaft.

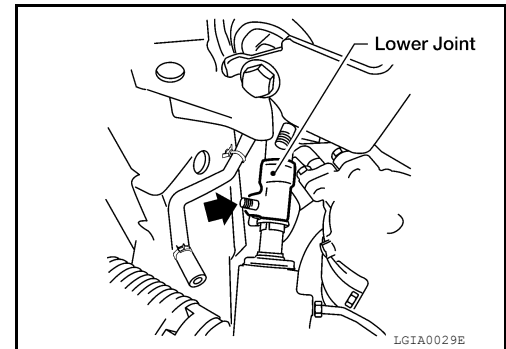

10. Remove nuts of steering gear assembly using power tool, then remove bolts and steering gear assembly.

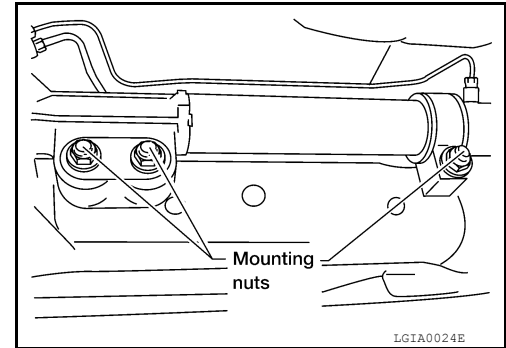

INSTALLATION

Installation is in the reverse order of removal.

CAUTION:

Do not reuse O-ring.

- After removing/installing or replacing steering components, check wheel alignment. Refer to [FSU-6, "Front Wheel Alignment"](#).
- After adjusting wheel alignment, adjust neutral position of steering angle sensor. Refer to [BRC-8, "ADJUSTMENT OF STEERING ANGLE SENSOR NEUTRAL POSITION : Special Repair Requirement"](#).
- With steering wheel in straight ahead position, make sure slit of lower joint fits with the projection on rear cover cap. Insert the joint until surface (A) contacts surface (B).

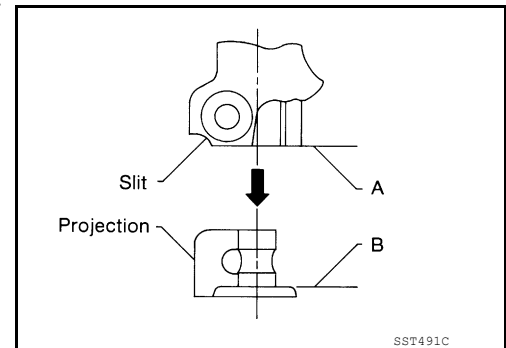

- After installation, bleed the air from the steering hydraulic system. Refer to [ST-13, "Air Bleeding Hydraulic System"](#).

INSPECTION AFTER INSTALLATION

Check if steering wheel turns smoothly when it is turned several times fully to the left and right lock positions.

STEERING COLUMN

< UNIT REMOVAL AND INSTALLATION >

STEERING COLUMN

Removal and Installation

INFOID:000000008632252

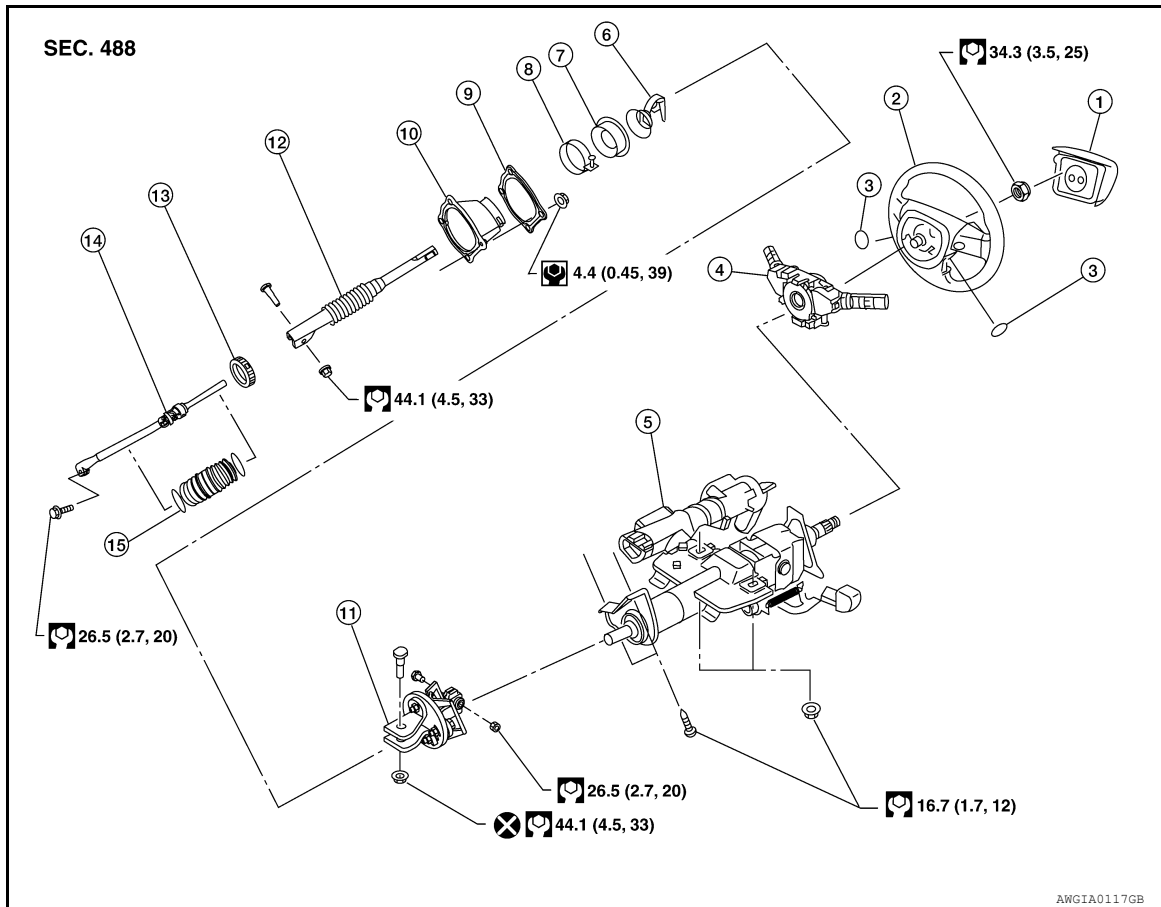

- | | | |
|---|-----------------------------|------------------------------|
| 1. Driver air bag module. Refer to SR-5 .
"Removal and Installation" . | 2. Steering wheel | 3. Steering wheel side cover |
| 4. Combination switch and spiral cable | 5. Steering column assembly | 6. Collar |
| 7. Hole cover seal | 8. Clamp | 9. Hole cover mounting plate |
| 10. Hole cover | 11. Upper joint | 12. Upper shaft |
| 13. Boot clamp | 14. Lower joint shaft | 15. Boot and clips (plastic) |

CAUTION:

- Care must be taken not to give axial impact to steering column assembly during removal and installation.
- Care must be taken not to move steering gear during removal of steering column assembly.
- Any time the ignition switch has been disconnected, removed and installed, the keys must be re-registered in the BCM. Refer to the CONSULT Immobilizer mode and follow the on-screen instructions.

REMOVAL

1. Disconnect battery negative and positive terminals and wait at least 3 minutes. Refer to [PG-77](#). ["Removal and Installation"](#).
2. If replacing the steering column, remove the combination switch and spiral cable from steering column assembly with combination switches attached. Refer to [SR-7](#). ["Removal and Installation"](#).

STEERING COLUMN

< UNIT REMOVAL AND INSTALLATION >

3. Remove tilt lever knob from tilt lever by inserting a suitable tool into slot of tilt lever knob, then depress tab and withdraw tilt lever knob.

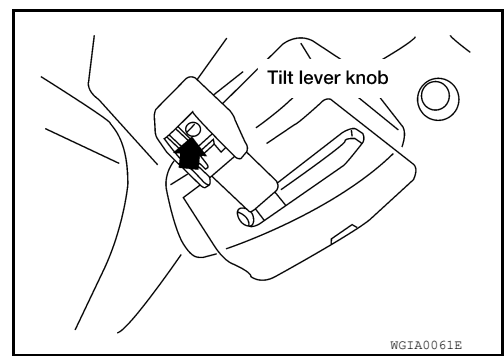

4. Remove instrument lower panel LH. Refer to [IP-14, "Removal and Installation"](#).
5. Remove steering column cover. Refer to [IP-11, "Exploded View"](#).
6. Remove knee protector screws and the knee protector.

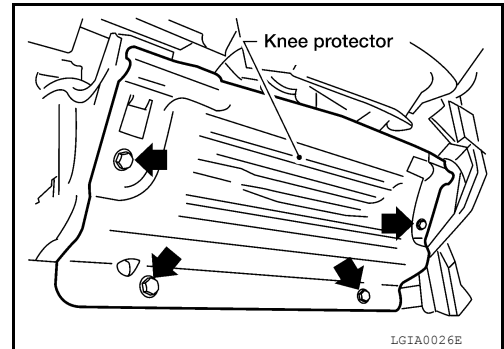

7. Remove lock nut and bolt, then separate upper joint from upper shaft.

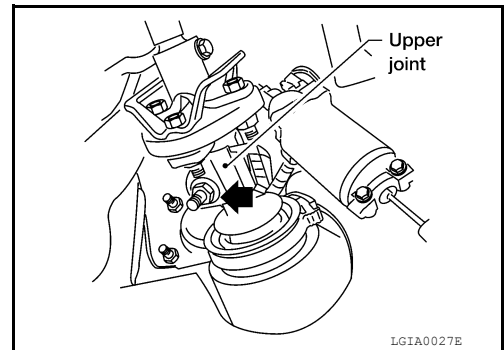

8. Disconnect electrical connectors, if necessary.
9. Remove the steering column assembly nuts and bolts, then remove steering column assembly.

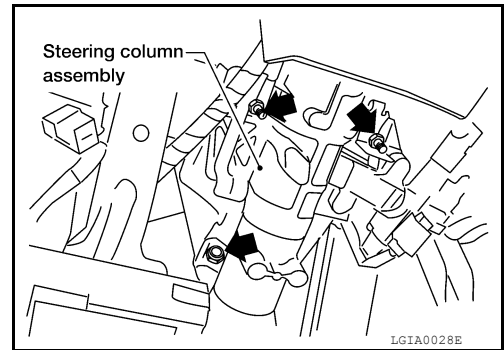

10. Remove hole cover seal and clamp, if necessary.
11. Remove nuts and hole cover mounting plate and hole cover from dash panel, if necessary.

A
B
C
D
E
F
ST
H
I
J
K
L
M
N
O
P

STEERING COLUMN

< UNIT REMOVAL AND INSTALLATION >

12. Raise vehicle, then remove lower joint shaft bolt and remove lower joint shaft and upper shaft from vehicle, if necessary.
 - During lower joint detachment, insert a tool into the yoke groove to prevent gouging damage.

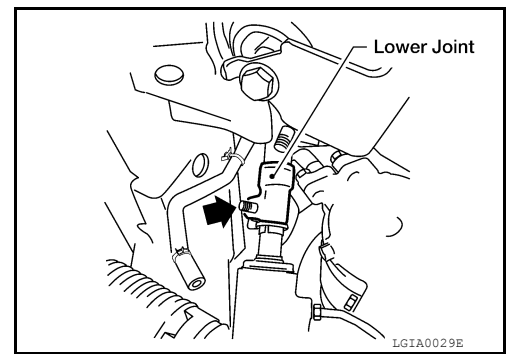

INSPECTION AFTER REMOVAL

- Check for damage to steering column assembly jacket tube. If damage is found, replace steering column assembly with new one.
- If vehicle has been in a collision, check column length (L), (L1) and (L2) as shown. If out of specification, replace steering column assembly with a new one.

Column length

L : Refer to [ST-35, "Steering Column"](#).

L1 : Refer to [ST-35, "Steering Column"](#).

L2 : Refer to [ST-35, "Steering Column"](#).

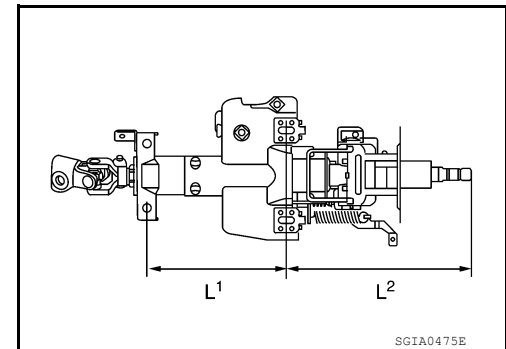
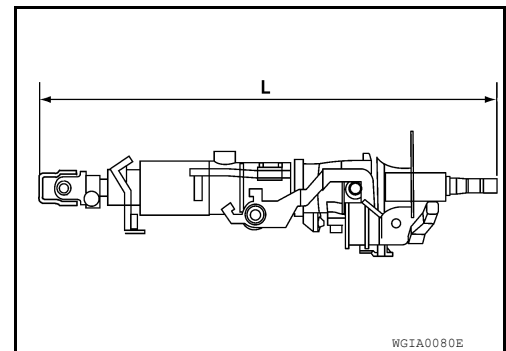

- Check for proper lubrication, apply multi-purpose grease as necessary to external joints and levers. Refer to [MA-17, "FOR USA AND CANADA : Fluids and Lubricants"](#).

INSTALLATION

Installation is in the reverse order of removal.

CAUTION:

When installing the steering column, finger-tighten all of the lower bracket and joint bolts; then tighten them to specification. Do not apply undue stress to the steering column.

NOTE:

STEERING COLUMN

< UNIT REMOVAL AND INSTALLATION >

Align slit of the coupling joint with projection on dust cover. Insert the joint until surface (A) contacts surface (B).

- After installation, turn steering wheel to make sure it moves smoothly. Make sure the number of turns are the same from the straight-forward position to left and right locks. Make sure that the steering wheel is in a neutral position when driving straight ahead.
- When installing steering column to steering member, install nut from front side of vehicle.
- The lower nut on the upper joint may not be reused.

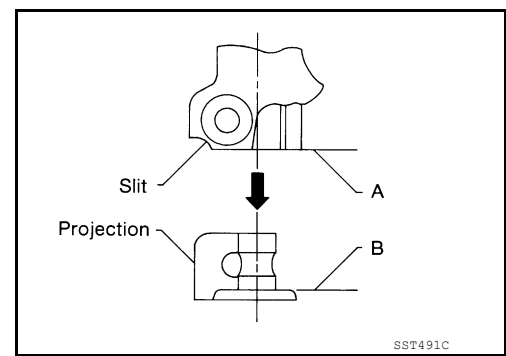

INSPECTION AFTER INSTALLATION

- After installing steering column to vehicle, check tilt device operation range is within specification.

Tilt range (A) : Refer to [ST-35, "Steering Column"](#).

Tilt mechanism range : Refer to [ST-35, "Steering Column"](#).

- Check if steering wheel operation can turn to the end of the left and right stops smoothly.

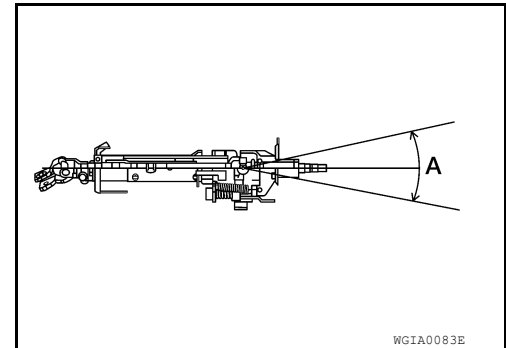

A
B
C
D
E
F
ST
H
I
J
K
L
M
N
O
P

STEERING WHEEL

< UNIT REMOVAL AND INSTALLATION >

STEERING WHEEL

Removal and Installation

INFOID:000000008632253

REMOVAL

1. Set the front wheels in the straight-ahead position.
2. Remove the driver air bag module. Refer to [SR-5, "Removal and Installation"](#).
3. Disconnect steering wheel switches.
4. Remove the steering wheel center nut.
5. Remove the steering wheel using Tool (A).

Tool number : ST27180001 (J-25726-A)

CAUTION:

Place a piece of tape across the spiral cable so it will not be rotated out of position.

6. Inspect the steering wheel near the puller holes for damage. If damaged, replace the steering wheel.
 - Remove steering wheel rear cover and steering wheel switches, if required.

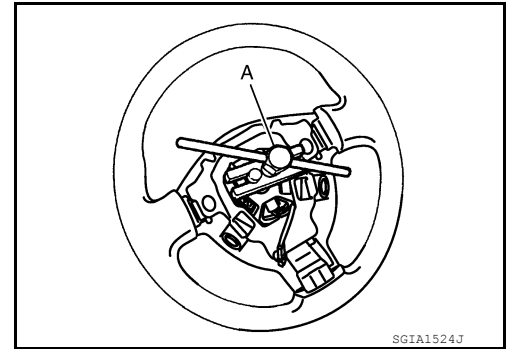

INSTALLATION

Installation is in the reverse order of removal.

- Align spiral cable correctly when installing steering wheel. Make sure that the spiral cable is in the neutral position. The neutral position is detected by turning left 2.5 revolutions from the right end position and ending with the knob at the top.
- Refer to [BRC-8, "ADJUSTMENT OF STEERING ANGLE SENSOR NEUTRAL POSITION : Special Repair Requirement"](#) for steering angle sensor adjustment.
- After the work is completed, perform self-diagnosis to make sure no malfunction is detected. Refer to [SRC-5, "Trouble Diagnosis with CONSULT"](#).
- Tighten steering wheel center nut to specification. Refer to [ST-24, "Removal and Installation"](#).

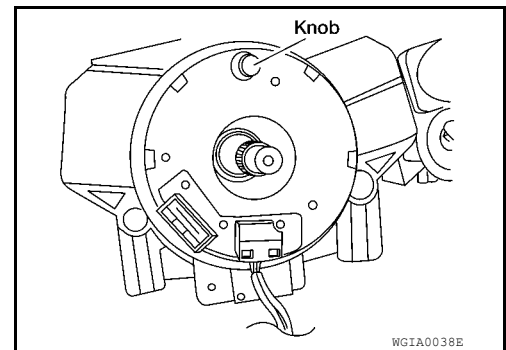

CAUTION:

- The spiral cable may snap due to steering operation if the cable is not installed in the correct position.
- With the steering linkage disconnected, the cable may snap by turning the steering wheel beyond the limited number of turns. The spiral cable can be turned counterclockwise about 2.5 turns from the neutral position.

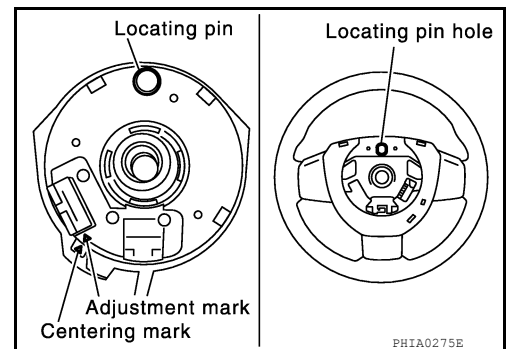

POWER STEERING OIL PUMP

< UNIT DISASSEMBLY AND ASSEMBLY >

UNIT DISASSEMBLY AND ASSEMBLY

POWER STEERING OIL PUMP

Disassembly and Assembly

INFOID:000000008632254

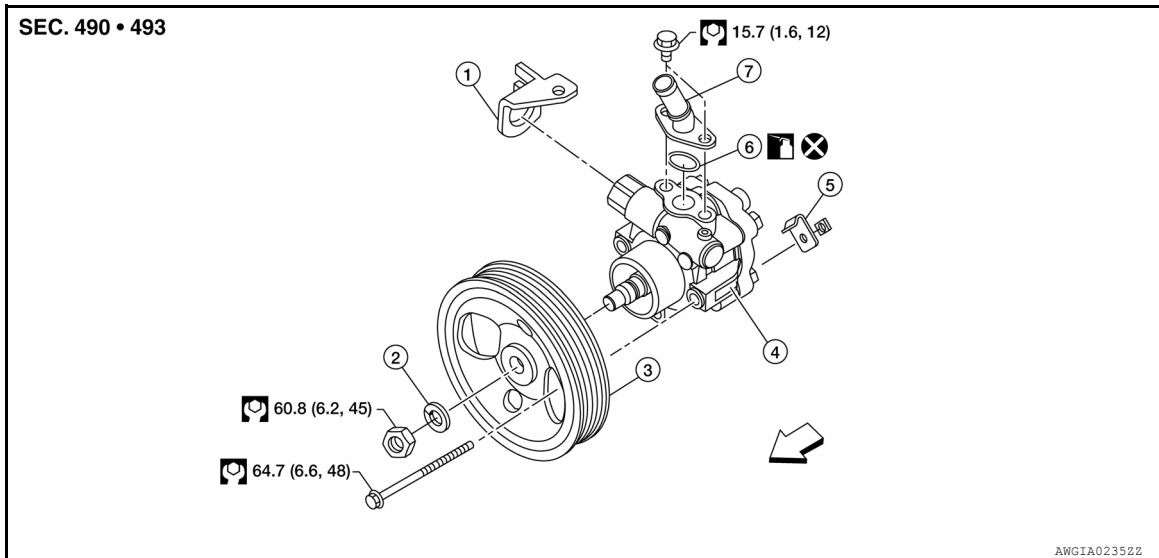

- | | | |
|------------------------|-------------------------------|-----------|
| 1. Bracket | 2. Spring washer | 3. Pulley |
| 4. Power steering pump | 5. High pressure hose bracket | 6. O-ring |
| 7. Suction pipe | ↔ Front | |

INSPECTION BEFORE DISASSEMBLY

Disassemble the power steering oil pump only if the following items are found.

- Deformed or damaged pulley, bracket, connector or suction pipe.
- Oil leakage from the suction pipe or connector.

DISASSEMBLY

NOTE:

Secure the power steering oil pump in a vise as needed.

1. Remove the connector bolt, connector and copper sealing washers.

CAUTION:

Do not reuse copper sealing washers.

2. Remove the suction pipe and O-ring.

CAUTION:

Do not reuse O-ring.

3. Remove the pulley nut and pulley.
4. Remove the bracket bolts and bracket.

INSPECTION AFTER DISASSEMBLY

Body Assembly Inspection

Check the power steering oil pump body assembly for damage. If any damage is found, replace with a new power steering oil pump assembly.

ASSEMBLY

Assembly is in the reverse order of disassembly.

CAUTION:

- **Do not reuse copper sealing washers.**
- **Do not reuse O-ring. Apply a coat of Genuine Nissan PSF or equivalent to the O-ring.**

POWER STEERING GEAR AND LINKAGE

< UNIT DISASSEMBLY AND ASSEMBLY >

POWER STEERING GEAR AND LINKAGE

Disassembly and Assembly

INFOID:000000008632255

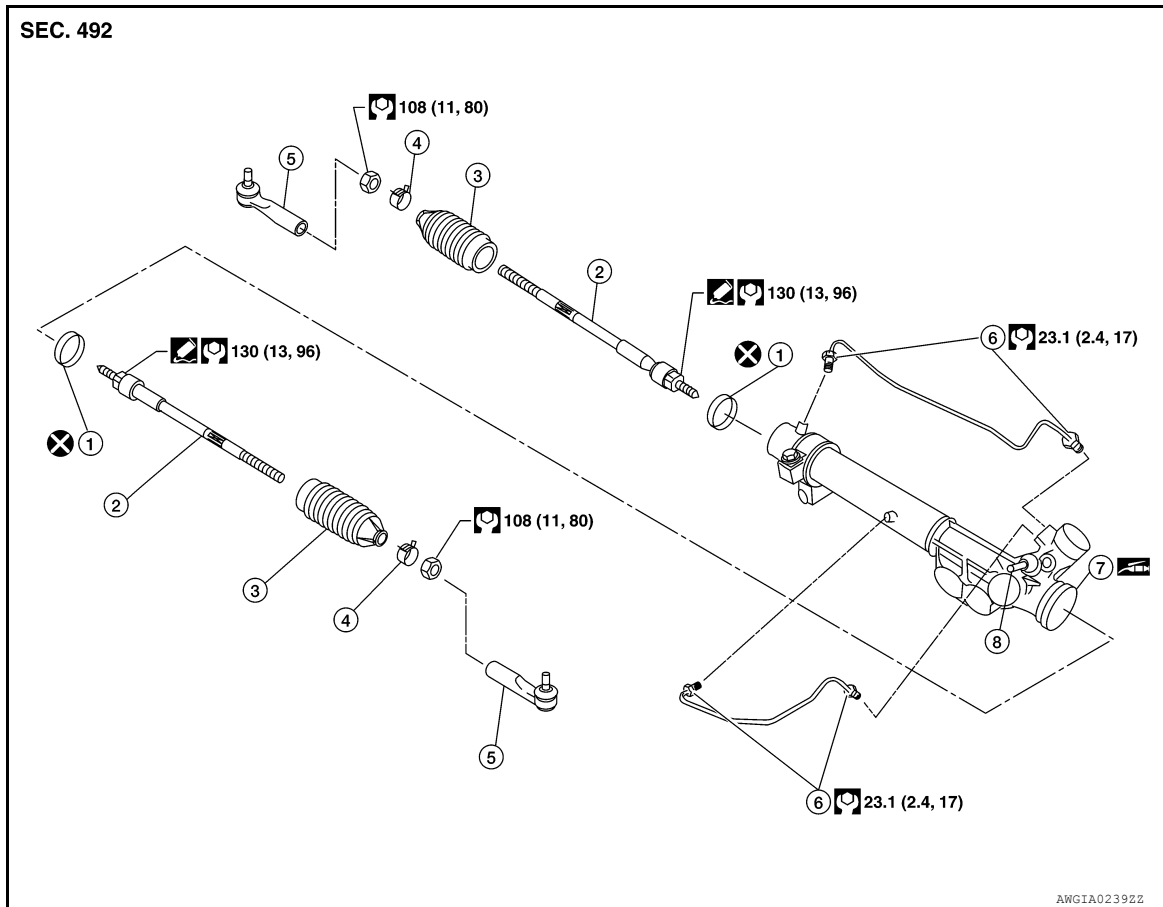

- | | | |
|--------------------------|-----------------|-------------------|
| 1. Boot clamp | 2. Inner socket | 3. Boot |
| 4. Boot clamp | 5. Outer socket | 6. Cylinder tubes |
| 7. Gear housing assembly | 8. Connector | |

CAUTION:

- Secure steering gear assembly in a vise, using copper plates or something similar to prevent it from being damaged. Do not grip cylinder with a vise.
- Before performing disassembly, clean steering gear assembly with kerosene. Be careful not to bring any kerosene into contact with the discharge and return port connectors.

DISASSEMBLY

1. Remove cylinder tubes from gear housing assembly.
2. Loosen lock nuts of outer sockets, and remove outer sockets.
3. Remove boot clamps of the small diameter side and the large diameter side, then remove boots.

CAUTION:

When removing boots, be careful not to damage inner socket and gear housing assembly. If they are damaged, change them to avoid oil leaks.

4. Remove inner sockets.

INSPECTION AFTER DISASSEMBLY

Boot

Check boot for tears, cracks and deformation. Replace if necessary.

POWER STEERING GEAR AND LINKAGE

< UNIT DISASSEMBLY AND ASSEMBLY >

Gear Housing Assembly

Check gear housing assembly for dents, cracks or damage. Replace as an assembly if necessary.

Outer Socket and Inner Socket

SWING TORQUE

- Measure the swing torque, using Tool. When ball stud and inner socket start moving the measured value must be within the specification. If the reading is outside the specification, replace the socket. Refer to [ST-36, "Steering Outer Socket and Inner Socket"](#).

Tool number : — (J-44372)

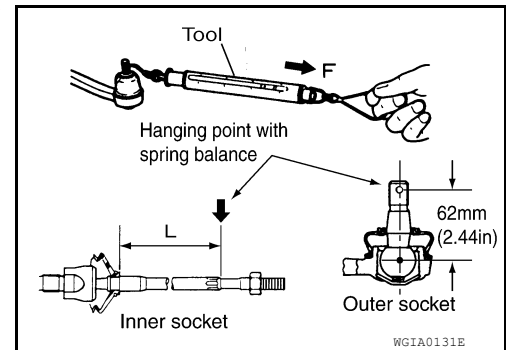

ROTATING TORQUE

- Measure the rotating torque, using Tool. If the value is outside the specification, replace the outer socket.

Tool number : ST3127S000 (J-25765-A)

Rotating torque : Refer to [ST-36, "Steering Outer Socket and Inner Socket"](#).

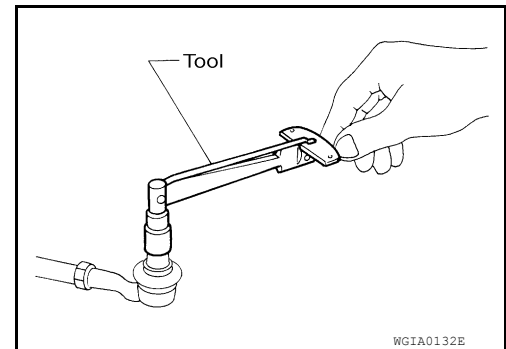

AXIAL END PLAY

- Apply a load of 490 N (50 kg-f, 110 lb-f) to the ball stud axially. Use a dial gauge to measure the amount of the movement that the stud makes. If the value is outside the specification, replace the sockets.

Outer socket : Refer to [ST-36, "Steering Outer Socket and Inner Socket"](#).

Inner socket : Refer to [ST-36, "Steering Outer Socket and Inner Socket"](#).

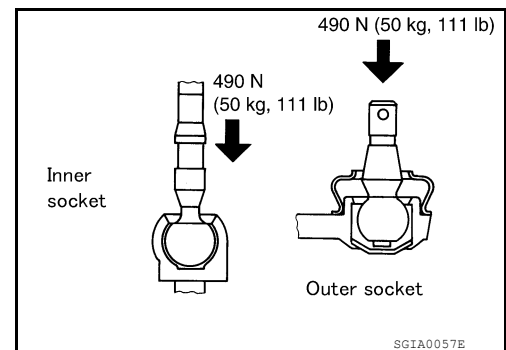

ASSEMBLY

1. Install the inner sockets.
2. Install the large-diameter side of the boots to the gear housing assembly.
3. Install the small-diameter side of the boots to the groove of the inner sockets.

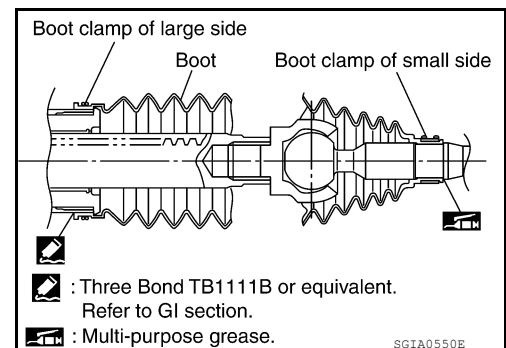

POWER STEERING GEAR AND LINKAGE

< UNIT DISASSEMBLY AND ASSEMBLY >

4. Install the boot clamps to the boots, as shown.

CAUTION:

Do not reuse the large-diameter boot clamps.

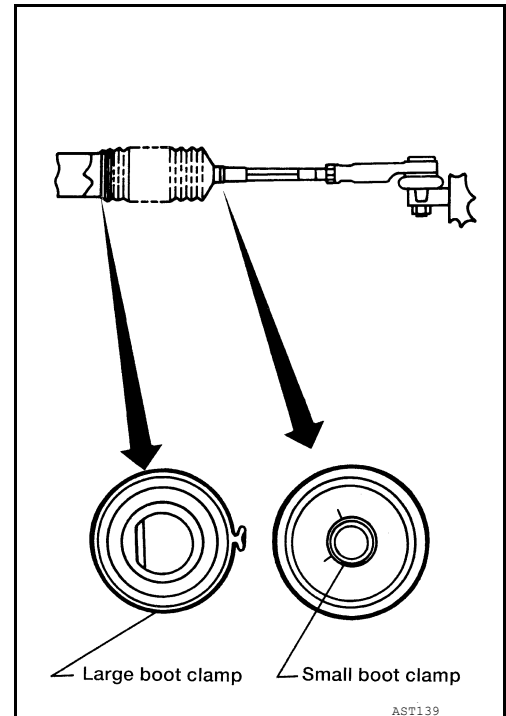

5. Crimp the large-diameter boot clamps, using Tool.

Tool number : KV40107300 (—)

6. Install the cylinder tubes to the gear housing assembly.
7. Install the lock nuts and outer sockets to the inner sockets.

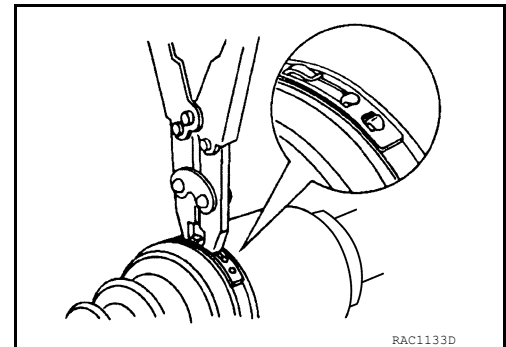

8. Thread the outer sockets onto the inner sockets to the specified length (L), then tighten the lock nuts to the specification. Reconfirm that the tie-rod length (L) is within specification.

Maximum inner socket : Refer to [ST-36, "Tie-rod"](#). length L

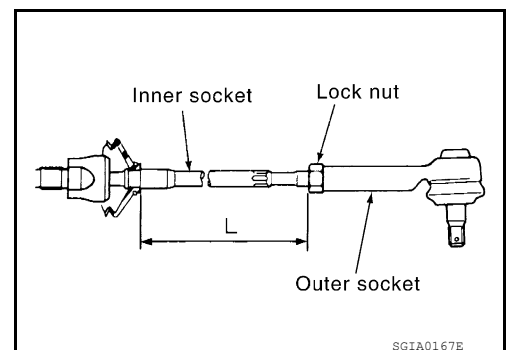

STEERING COLUMN

< UNIT DISASSEMBLY AND ASSEMBLY >

STEERING COLUMN

Disassembly and Assembly

INFOID:000000008632256

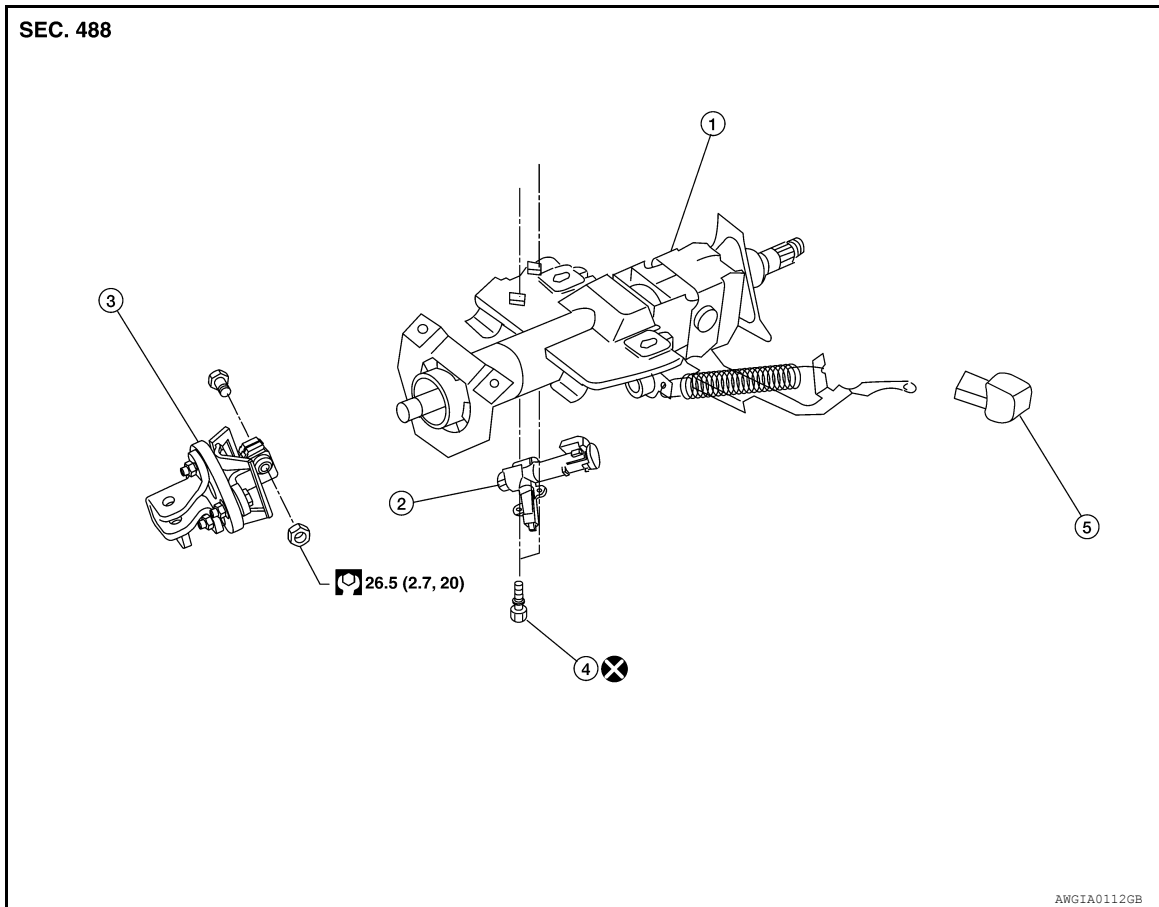

- | | | |
|-----------------------------|--------------------|----------------|
| 1. Steering column assembly | 2. Ignition switch | 3. Upper joint |
| 4. Self-shear screw | 5. Tilt lever knob | |

DISASSEMBLY

1. Remove bolt from upper joint, then remove upper joint from steering column assembly.
2. Remove ignition switch tamper resistant self-shear type screws with a drill or other appropriate tool.

ASSEMBLY

Assembly is in the reverse order of disassembly.

- Install new tamper resistant self-shear type screws.

CAUTION:

Any time the ignition switch has been disconnected, removed and installed, the keys must be re-registered in the BCM. Refer to the CONSULT Immobilizer mode and follow the on-screen instructions.

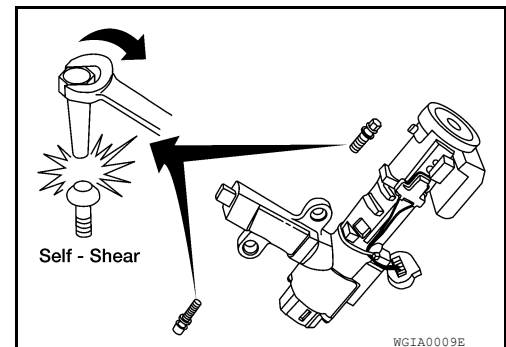

INSPECTION AFTER ASSEMBLY

When the steering wheel does not turn smoothly, check the steering column as follows:

1. Check the column bearings for damage or unevenness. Replace the steering column as an assembly, if necessary.

STEERING COLUMN

< UNIT DISASSEMBLY AND ASSEMBLY >

2. Check the column tube for deformation or breakage. Replace the steering column as an assembly, if necessary.
3. If the vehicle has been involved in a collision, or if noise and rattles are heard during a turn, check the length (L) of the column.
If out of specification, replace the steering column as an assembly.

Steering column length

- L : Refer to [ST-35, "Steering Column"](#).
L1 : Refer to [ST-35, "Steering Column"](#).
L2 : Refer to [ST-35, "Steering Column"](#).

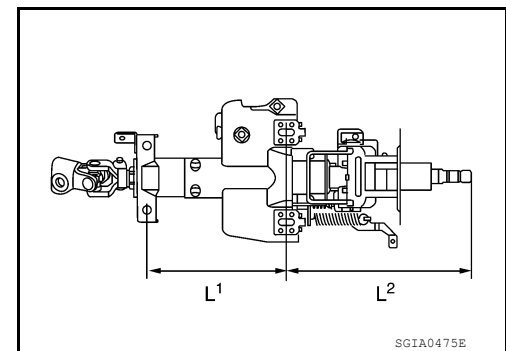
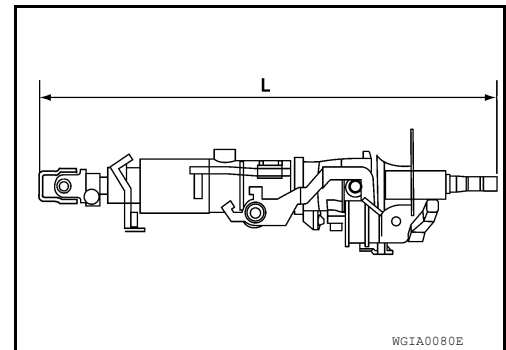

4. Check for proper lubrication of joints and levers, apply multi-purpose grease as necessary. Refer to [MA-17, "FOR USA AND CANADA : Fluids and Lubricants"](#).
5. Check for wear around the seal edges, replace steering column assembly as necessary.
6. Check for corrosion or pitting around the seal sliding area.
7. After installing the steering column, check the tilt mechanism for proper operation.

Tilt range (A) : Refer to [ST-35, "Steering Column"](#).

Tilt mechanism range : Refer to [ST-35, "Steering Column"](#).

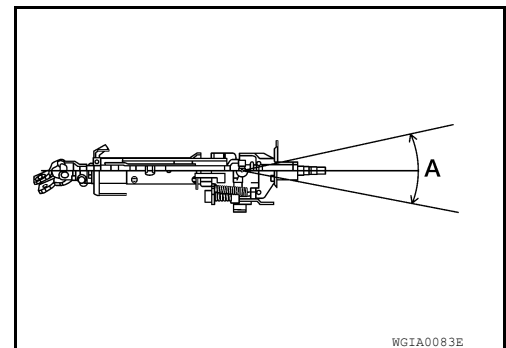

CAUTION:

- Do not exert any load or impact in the axial direction immediately before or after column removal.
- After installation, check for smooth steering wheel rotation, without any catches or noise.
- Replace the column if it is depleted of grease, worn, damaged, or if any scratches or coating separation is present on the shaft seal area causing grease to leak out of sealed steering column assembly.

SERVICE DATA AND SPECIFICATIONS (SDS)

< SERVICE DATA AND SPECIFICATIONS (SDS)

SERVICE DATA AND SPECIFICATIONS (SDS)

SERVICE DATA AND SPECIFICATIONS (SDS)

Steering Wheel

INFOID:0000000008632257

End play of the axle direction for steering wheel	0 mm (0 in)
Steering wheel play on the outer circumference	0 – 35 mm (0 – 1.38 in)
Steering wheel turning force	39 N (4 kg-f, 9 lb-f) or less

Steering Column

INFOID:0000000008632258

Unit: mm (in)

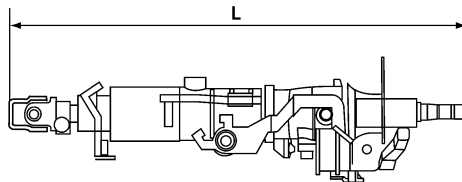

WGIA0080E

Steering column assembly length (L)	640 (25.20)
-------------------------------------	-------------

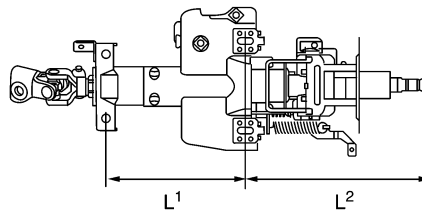

SGIA0475E

Steering column length (L ¹)	165.1 (6.50)
Steering column length (L ²)	258 (10.16)

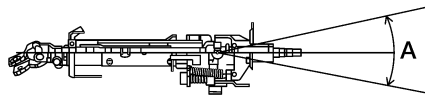

WGIA0083E

Tilt range (A)	15°
Tilt mechanism range	3° per notch at 5 steps

SERVICE DATA AND SPECIFICATIONS (SDS)

< SERVICE DATA AND SPECIFICATIONS (SDS)

Steering Outer Socket and Inner Socket

INFOID:000000008632259

Steering gear type	PR26AM
--------------------	--------

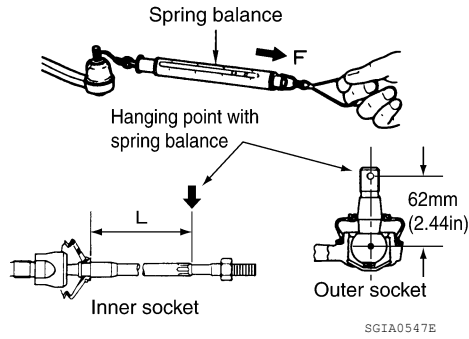

Tie-rod ball joint outer socket	Swinging torque	0.3 – 2.9 N·m (0.03 – 0.29 kg-m, 3 – 25 in-lb)
	Measurement on spring balance (F) • Measuring point: cotter pin hole of stud	4.84 – 46.7 N (0.50 – 4.7 kg-f, 4 – 34 lb-f)
	Rotating torque	0.3 – 2.9 N·m (0.03 – 0.29 kg-m, 3 – 25 in-lb)
	Axial end play	0.5 mm (0.020 in) or less
Tie-rod ball joint inner socket	Swinging torque	1.0 – 7.8 N·m (0.11 – 0.79 kg-m, 9 – 69 in-lb)
	Measurement on spring balance • Measuring point: L mark see above, L=83.2 mm (3.276 in).	12.1 – 93.7 N (1.3 – 9.5 kg-f, 9 – 69 lb-f)
	Axial end play	0.2 mm (0.008 in) or less

Tie-rod

INFOID:000000008632260

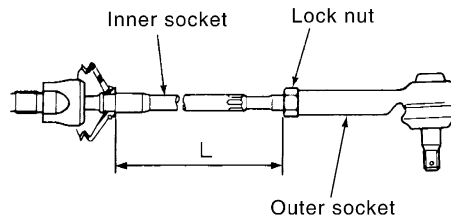

Tie-rod maximum length (L)	115.2 mm (4.54 in)
----------------------------	--------------------

SERVICE DATA AND SPECIFICATIONS (SDS)

< SERVICE DATA AND SPECIFICATIONS (SDS)

Steering Gear

INFOID:000000008632261

Steering gear model	PR26AM
---------------------	--------

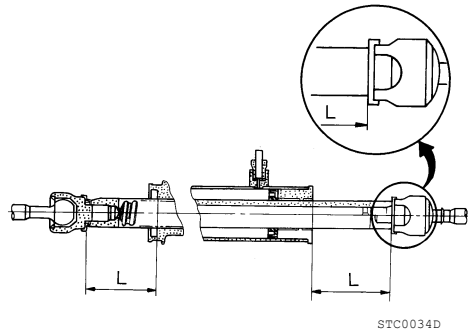

Rack neutral position, dimension (L) (rack stroke)	85.5 mm (3.36 in)	
Rack sliding force	Standard	308 ± 45 N (31.4 ± 4.6 kg-f, 69.2 ± 10.1 lb-f)
	Service limit (Minimum)	240 N (24.5 kg-f, 54.0 lb-f)

Oil Pump

INFOID:000000008632262

Oil pump relief oil pressure	9.0 – 9.8 mPa (91.77 – 99.93 kg/cm ² , 1305.34 – 1421.37 psi)
------------------------------	--

Steering Fluid

INFOID:000000008632263

Fluid capacity	Approx. 1.0 ℓ (1-1/8 US qt, 7/8 Imp qt)
----------------	---

A
B
C
D
E
F
ST
H
I
J
K
L
M
N
O
P