

SECTION VTL
VENTILATION SYSTEM

A
B
C
D
E
F
G
H
I
J
K
L
M
N
O
P

CONTENTS

PRECAUTION	2	Removal and Installation	12
PRECAUTIONS	2	VARIABLE BLOWER CONTROL	14
Precaution for Supplemental Restraint System (SRS) "AIR BAG" and "SEAT BELT PRE-TENSIONER"	2	Components	14
Precaution Necessary for Steering Wheel Rotation After Battery Disconnect	2	Removal and Installation	15
Precaution for Work	3	HEATER & COOLING UNIT ASSEMBLY	16
Precaution for Working with HFC-134a (R-134a).....	3	Component	16
PREPARATION	4	Removal and Installation	17
PREPARATION	4	EVAPORATOR	19
Special Service Tool	4	Removal and Installation for Front Evaporator and Expansion Valve	19
Commercial Service Tool	4	Removal and Installation for Rear Evaporator	20
SYSTEM DESCRIPTION	5	EXPANSION VALVE	22
IN-CABIN MICROFILTER	5	Removal and Installation for Front Expansion Valve	22
Description	5	Removal and Installation for Rear Expansion Valve	22
PERIODIC MAINTENANCE	6	HEATER CORE	23
IN-CABIN MICROFILTER	6	Component	23
Removal and Installation	6	Removal and Installation	24
REMOVAL AND INSTALLATION	7	DEFROSTER DOOR MOTOR	26
CONTROL UNIT	7	Removal and Installation	26
Removal and Installation	7	INTAKE DOOR MOTOR	27
IN-VEHICLE SENSOR	9	Removal and Installation	27
Removal and Installation	9	MODE DOOR MOTOR	28
OPTICAL SENSOR	10	Components	28
Removal and Installation	10	Removal and Installation	29
INTAKE SENSOR	11	AIR MIX DOOR MOTOR	30
Removal and Installation	11	Component	30
BLOWER MOTOR	12	Removal and Installation	31
Component	12	DUCTS AND GRILLES	33
		Component	33
		Removal and Installation	36

VTL

PRECAUTIONS

< PRECAUTION >

PRECAUTION

PRECAUTIONS

Precaution for Supplemental Restraint System (SRS) "AIR BAG" and "SEAT BELT PRE-TENSIONER"

INFOID:000000008632151

The Supplemental Restraint System such as "AIR BAG" and "SEAT BELT PRE-TENSIONER", used along with a front seat belt, helps to reduce the risk or severity of injury to the driver and front passenger for certain types of collision. This system includes seat belt switch inputs and dual stage front air bag modules. The SRS system uses the seat belt switches to determine the front air bag deployment, and may only deploy one front air bag, depending on the severity of a collision and whether the front occupants are belted or unbelted. Information necessary to service the system safely is included in the SR and SB section of this Service Manual.

WARNING:

- To avoid rendering the SRS inoperative, which could increase the risk of personal injury or death in the event of a collision which would result in air bag inflation, all maintenance must be performed by an authorized NISSAN/INFINITI dealer.
- Improper maintenance, including incorrect removal and installation of the SRS, can lead to personal injury caused by unintentional activation of the system. For removal of Spiral Cable and Air Bag Module, see the SR section.
- Do not use electrical test equipment on any circuit related to the SRS unless instructed to in this Service Manual. SRS wiring harnesses can be identified by yellow and/or orange harnesses or harness connectors.

PRECAUTIONS WHEN USING POWER TOOLS (AIR OR ELECTRIC) AND HAMMERS

WARNING:

- When working near the Airbag Diagnosis Sensor Unit or other Airbag System sensors with the Ignition ON or engine running, DO NOT use air or electric power tools or strike near the sensor(s) with a hammer. Heavy vibration could activate the sensor(s) and deploy the air bag(s), possibly causing serious injury.
- When using air or electric power tools or hammers, always switch the Ignition OFF, disconnect the battery, and wait at least 3 minutes before performing any service.

Precaution Necessary for Steering Wheel Rotation After Battery Disconnect

INFOID:000000008632152

NOTE:

- This Procedure is applied only to models with Intelligent Key system and NATS (NISSAN ANTI-THEFT SYSTEM).
- Remove and install all control units after disconnecting both battery cables with the ignition knob in the "LOCK" position.
- Always use CONSULT to perform self-diagnosis as a part of each function inspection after finishing work. If DTC is detected, perform trouble diagnosis according to self-diagnostic results.

For models equipped with the Intelligent Key system and NATS, an electrically controlled steering lock mechanism is adopted on the key cylinder.

For this reason, if the battery is disconnected or if the battery is discharged, the steering wheel will lock and steering wheel rotation will become impossible.

If steering wheel rotation is required when battery power is interrupted, follow the procedure below before starting the repair operation.

OPERATION PROCEDURE

1. Connect both battery cables.

NOTE:

Supply power using jumper cables if battery is discharged.

2. Use the Intelligent Key or mechanical key to turn the ignition switch to the "ACC" position. At this time, the steering lock will be released.
3. Disconnect both battery cables. The steering lock will remain released and the steering wheel can be rotated.
4. Perform the necessary repair operation.

PRECAUTIONS

< PRECAUTION >

5. When the repair work is completed, return the ignition switch to the "LOCK" position before connecting the battery cables. (At this time, the steering lock mechanism will engage.)
6. Perform a self-diagnosis check of all control units using CONSULT.

Precaution for Work

INFOID:000000008632153

- When removing or disassembling each component, be careful not to damage or deform it. If a component may be subject to interference, be sure to protect it with a shop cloth.
- When removing (disengaging) components with a screwdriver or similar tool, be sure to wrap the component with a shop cloth or vinyl tape to protect it.
- Protect the removed parts with a shop cloth and prevent them from being dropped.
- Replace a deformed or damaged clip.
- If a part is specified as a non-reusable part, always replace it with a new one.
- Be sure to tighten bolts and nuts securely to the specified torque.
- After installation is complete, be sure to check that each part works properly.
- Follow the steps below to clean components:
 - Water soluble dirt:
 - Dip a soft cloth into lukewarm water, wring the water out of the cloth and wipe the dirty area.
 - Then rub with a soft, dry cloth.
 - Oily dirt:
 - Dip a soft cloth into lukewarm water with mild detergent (concentration: within 2 to 3%) and wipe the dirty area.
 - Then dip a cloth into fresh water, wring the water out of the cloth and wipe the detergent off.
 - Then rub with a soft, dry cloth.
 - Do not use organic solvent such as thinner, benzene, alcohol or gasoline.
 - For genuine leather seats, use a genuine leather seat cleaner.

Precaution for Working with HFC-134a (R-134a)

INFOID:000000008632154

WARNING:

- **CFC-12 (R-12) refrigerant and HFC-134a (R-134a) refrigerant are not compatible. If the refrigerants are mixed compressor failure is likely to occur. Refer to HA-4, "Contaminated Refrigerant". To determine the purity of HFC-134a (R-134a) in the vehicle and recovery tank, use recovery/recycling equipment and refrigerant identifier.**
- **Use only specified oil for the HFC-134a (R-134a) A/C system and HFC-134a (R-134a) components. If oil other than that specified is used, compressor failure is likely to occur.**
- **The specified HFC-134a (R-134a) oil rapidly absorbs moisture from the atmosphere. The following handling precautions must be observed:**
 - **When removing refrigerant components from a vehicle, immediately cap (seal) the component to minimize the entry of moisture from the atmosphere.**
 - **When installing refrigerant components to a vehicle, do not remove the caps (unseal) until just before connecting the components. Connect all refrigerant loop components as quickly as possible to minimize the entry of moisture into system.**
 - **Only use the specified oil from a sealed container. Immediately reseal containers of oil. Without proper sealing, oil will become moisture saturated and should not be used.**
 - **Avoid breathing A/C refrigerant and oil vapor or mist. Exposure may irritate eyes, nose and throat. Remove HFC-134a (R-134a) from the A/C system using certified service equipment meeting requirements of SAE J2210 [HFC-134a (R-134a) recycling equipment], or J2209 [HFC-134a (R-134a) recovery equipment]. If accidental system discharge occurs, ventilate work area before resuming service. Additional health and safety information may be obtained from refrigerant and oil manufacturers.**
 - **Do not allow A/C oil to come in contact with styrofoam parts. Damage may result.**

A
B
C
D
E
F
G
H
J
K
L
M
N
O
P

VTL

PREPARATION

< PREPARATION >

PREPARATION

PREPARATION

Special Service Tool

INFOID:000000008632155

The actual shapes of Kent-Moore tools may differ from those of special service tools illustrated here.

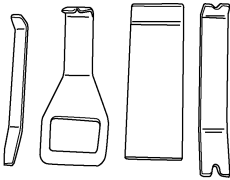
Tool number (Kent-Moore No.) Tool name	Description
<p>— (J-46534) Trim tool set</p>  <p style="text-align: center;">AWJIA0483ZZ</p>	<p>Removing trim components</p>

Commercial Service Tool

INFOID:000000008632156

Tool name	Description
<p>Power tool</p>  <p style="text-align: center;">PIIB1407E</p>	<p>Loosening nuts, screws and bolts</p>

IN-CABIN MICROFILTER

< SYSTEM DESCRIPTION >

SYSTEM DESCRIPTION

IN-CABIN MICROFILTER

Description

INFOID:000000008632157

FUNCTION

The air inside the passenger compartment is filtered by the in-cabin microfilters when the heater or A/C controls are set on either the recirculation or fresh mode. The two in-cabin microfilters are located in the front heater and cooling unit assembly. The rear heater and cooling unit assembly only draws in air from the passenger compartment to recirculate into the passenger compartment, so the rear heater and cooling unit assembly is not equipped with in-cabin microfilters.

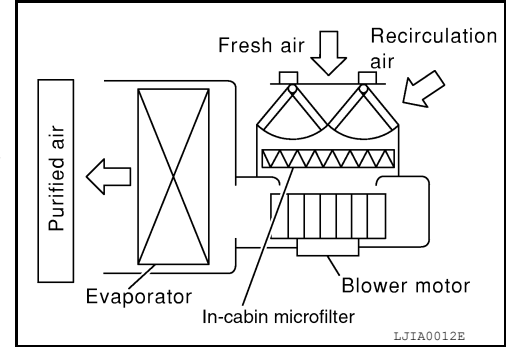

REPLACEMENT TIMING

Replacement of the two in-cabin microfilters is recommended on a regular interval depending on the driving conditions. Refer to [MA-10. "FOR USA AND CANADA : Introduction of Periodic Maintenance"](#). It may also be necessary to replace the two in-cabin microfilters as part of a component replacement if the in-cabin microfilters are damaged.

A
B
C
D
E
F
G
H
J
K
L
M
N
O
P

VTL

IN-CABIN MICROFILTER

< PERIODIC MAINTENANCE >

PERIODIC MAINTENANCE

IN-CABIN MICROFILTER

Removal and Installation

INFOID:000000008632158

REPLACEMENT PROCEDURE

1. Remove the glove box assembly from the instrument panel. Refer to [IP-17. "Removal and Installation"](#).
2. Remove the screw and remove the in-cabin microfilter cover (A) as shown.
3. Remove the two in-cabin microfilters from the front heater and cooling unit assembly housing.

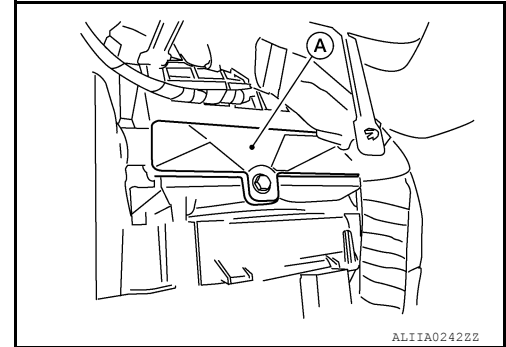

4. Insert the first new in-cabin microfilter into the front heater and cooling unit assembly housing and slide it over to the right. Insert the second new in-cabin microfilter into the front heater and cooling unit assembly housing as shown.

NOTE:

The in-cabin microfilters are marked with air flow arrows. The end of the microfilter with the arrow should face the rear of the vehicle. The arrows should point downward.

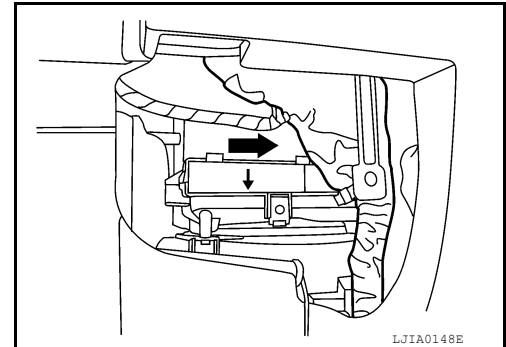

5. Install the in-cabin microfilter cover (A).

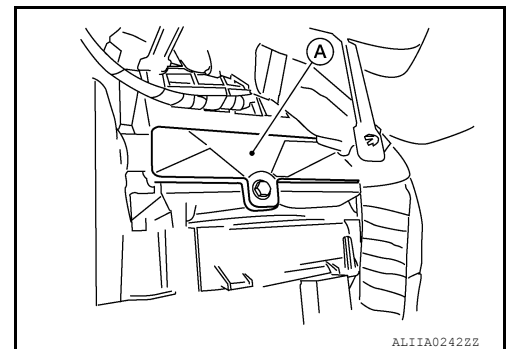

6. Install the glove box assembly in the instrument panel. Refer to [IP-17. "Removal and Installation"](#).
7. Fill out the date information on the small replacement label and attach it to the glove box lid.

CONTROL UNIT

< REMOVAL AND INSTALLATION >

REMOVAL AND INSTALLATION

CONTROL UNIT

Removal and Installation

INFOID:000000008632159

A/C and AV SWITCH ASSEMBLY

Removal and Installation

The front A/C switch is integrated into the A/C and AV switch assembly in cluster lid C in the instrument panel. Refer to [AV-105, "Removal and Installation"](#).

A/C AUTO AMP.

Removal

1. Remove the display unit. Refer to [AV-266, "Removal and Installation"](#).
2. Remove the four screws (A) and remove the A/C auto amp. (1) from the back of the display unit (2).

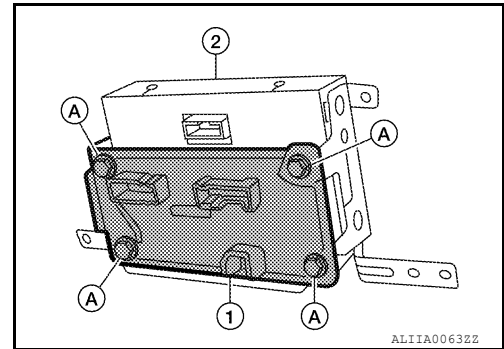

Installation

Installation is in the reverse order of removal.

REAR AIR CONTROL (FRONT)

Removal

1. Remove the front roof console finisher from the headlining. Refer to [INT-21, "Removal and Installation"](#).
2. Remove the three screws (A) and remove the rear air control (front) (1).

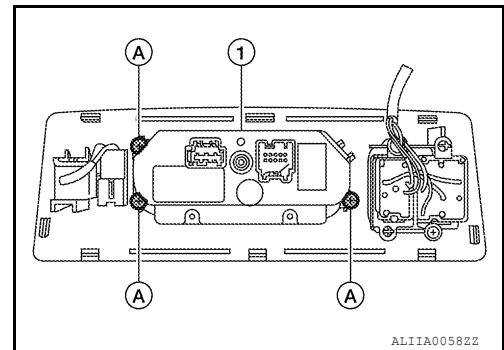

Installation

Installation is in the reverse order of removal.

REAR AIR CONTROL (REAR)

Removal

1. Remove the rear roof console finisher from the headlining. Refer to [INT-21, "Removal and Installation"](#).

CONTROL UNIT

< REMOVAL AND INSTALLATION >

2. Remove the three screws (A) and remove the rear air control (rear) (1).

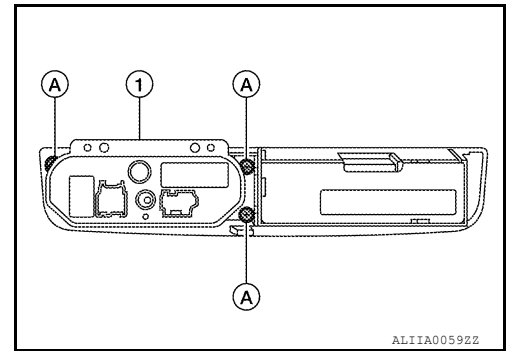

Installation

Installation is in the reverse order of removal.

IN-VEHICLE SENSOR

< REMOVAL AND INSTALLATION >

IN-VEHICLE SENSOR

Removal and Installation

INFOID:000000008632160

REMOVAL

1. Remove the lower instrument panel LH. Refer to [IP-11. "Exploded View"](#).
2. Remove the two screws (A) and remove the in-vehicle sensor (1).

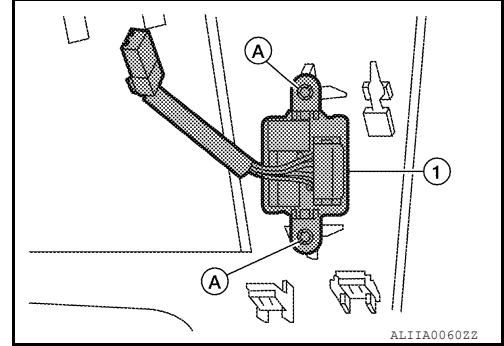

INSTALLATION

Installation is in the reverse order of removal.

A
B
C
D
E
F
G
H
J
K
L
M
N
O
P

VTL

OPTICAL SENSOR

< REMOVAL AND INSTALLATION >

OPTICAL SENSOR

Removal and Installation

INFOID:000000008632161

REMOVAL

1. Remove the defroster grille from the instrument panel. Refer to [IP-11. "Exploded View"](#).
2. Disconnect the optical sensor connector (2).
3. Twist the optical sensor (1) counter clockwise to remove it from the defroster grille.

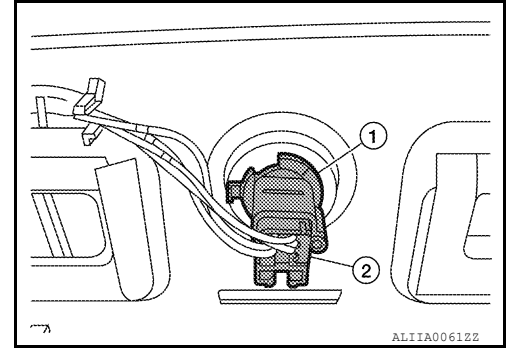

INSTALLATION

Installation is in the reverse order of removal.

INTAKE SENSOR

< REMOVAL AND INSTALLATION >

INTAKE SENSOR

Removal and Installation

INFOID:000000008632162

REMOVAL

1. Remove the instrument lower panel RH and glove box. Refer to [IP-17. "Removal and Installation"](#).
2. Disconnect the intake sensor electrical connector.

NOTE:

The intake sensor is located on the top of the front heater and cooling unit assembly next to the A/C evaporator cover.

3. Pull up on the intake sensor to remove the intake sensor from the front heater and cooling unit assembly.

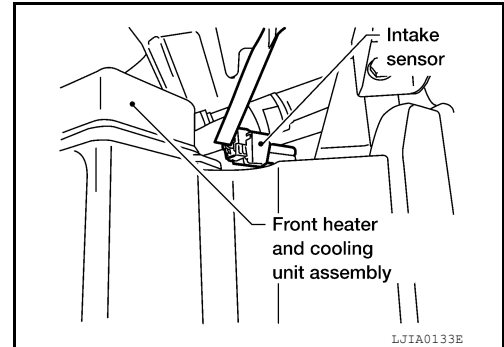

INSTALLATION

Installation is in the reverse order of removal.

A

B

C

D

E

F

G

H

VTL

J

K

L

M

N

O

P

BLOWER MOTOR

< REMOVAL AND INSTALLATION >

BLOWER MOTOR

Component

INFOID:000000008632163

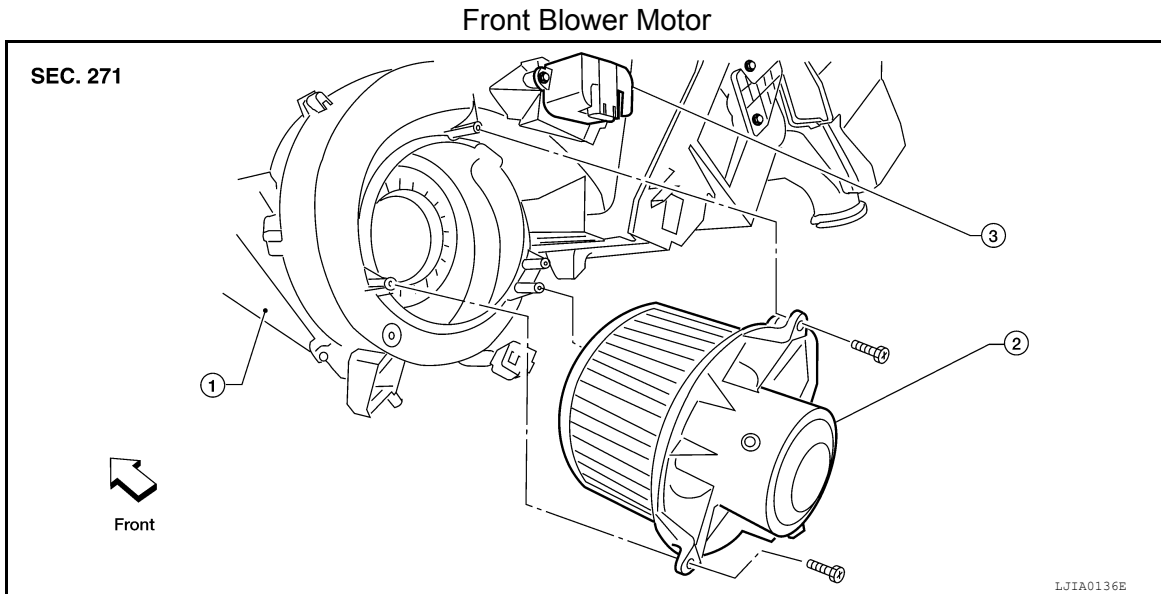

1. Front heater and cooling unit assembly 2. Front blower motor 3. Front variable blower control

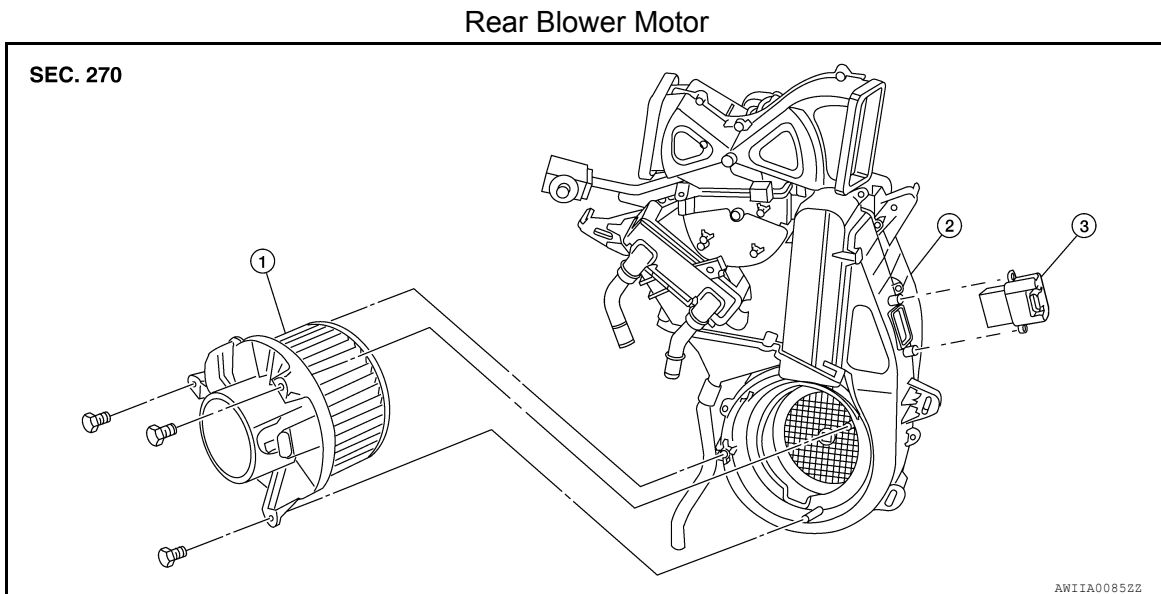

1. Rear blower motor 2. Rear heater and cooling unit assembly 3. Rear variable blower control

Removal and Installation

INFOID:000000008632164

FRONT BLOWER MOTOR

Removal

1. Remove the glove box assembly. Refer to [IP-17, "Removal and Installation"](#).
2. Disconnect the front blower motor electrical connector.
3. Remove the three screws and remove the front blower motor.
4. Remove the blower motor wheel as necessary to transfer to the new blower motor.

Installation

Installation is in the reverse order of removal.

BLOWER MOTOR

< REMOVAL AND INSTALLATION >

REAR BLOWER MOTOR

Removal

1. Remove the rear heater and cooling unit assembly. Refer to [VTL-17. "Removal and Installation"](#).
2. Disconnect the rear blower motor electrical connector.
3. Remove the three screws and remove the rear blower motor.
4. Remove the blower motor wheel as necessary to transfer to the new blower motor.

Installation

Installation is in the reverse order of removal.

A

B

C

D

E

F

G

H

VTL

J

K

L

M

N

O

P

VARIABLE BLOWER CONTROL

< REMOVAL AND INSTALLATION >

VARIABLE BLOWER CONTROL

Components

INFOID:000000008632165

Front Variable Blower Control - Front Heater and Cooling Unit Assembly

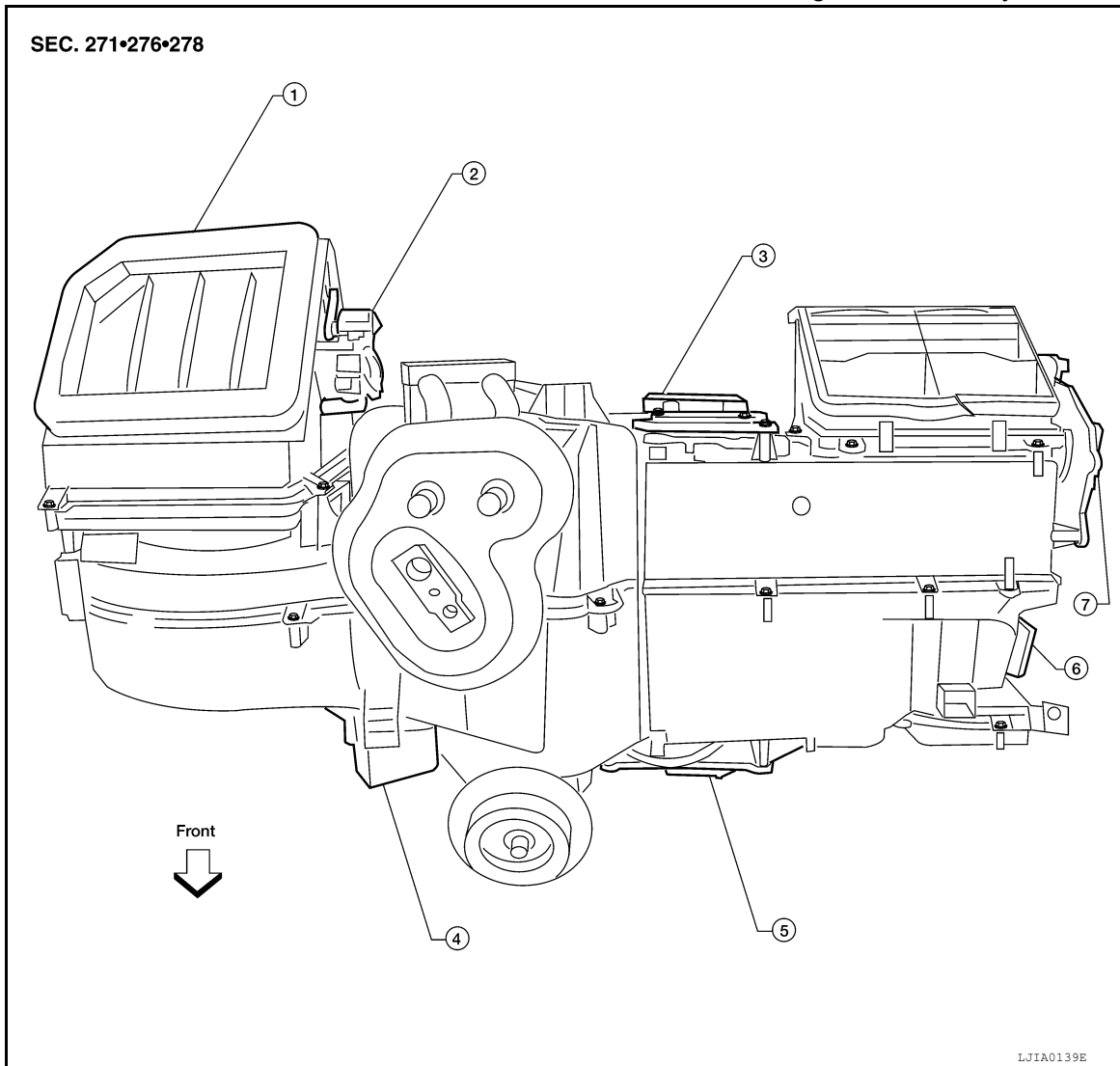

- | | | |
|---|-----------------------------------|--------------------------------|
| 1. Front heater and cooling unit assembly | 2. Intake door motor | 3. Air mix door motor (driver) |
| 4. Front variable blower control | 5. Air mix door motor (passenger) | 6. Mode door motor |
| 7. Defroster door motor | | |

VARIABLE BLOWER CONTROL

< REMOVAL AND INSTALLATION >

Rear Variable Blower Control - Rear Heater and Cooling Unit Assembly

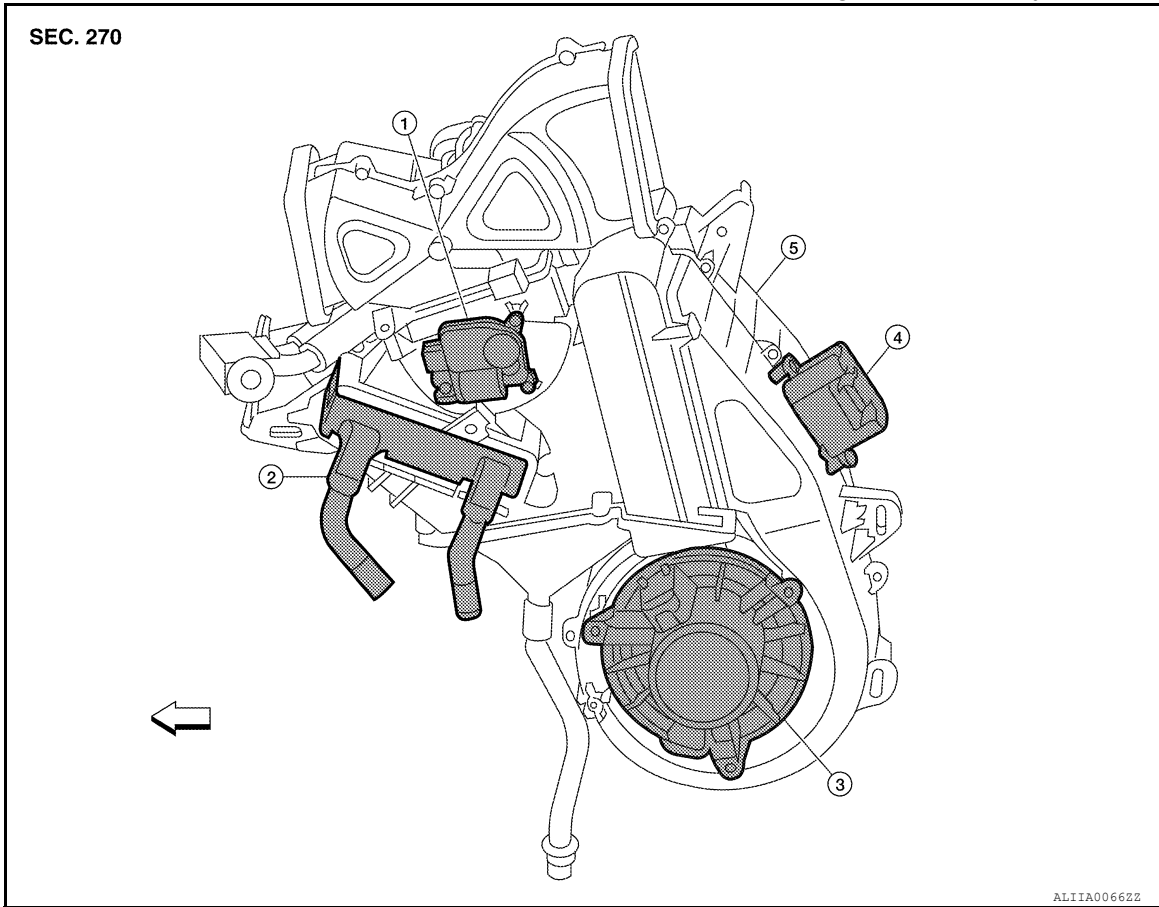

- | | | |
|---------------------------------|--|-----------------|
| 1. Air mix door motor | 2. Heater core | 3. Blower motor |
| 4. Rear variable blower control | 5. Rear heater and cooling unit assembly | ← Front |

Removal and Installation

INFOID:000000008632166

FRONT VARIABLE BLOWER CONTROL

Removal

1. Remove the glove box assembly. Refer to [IP-17, "Removal and Installation"](#).
2. Disconnect the variable blower control electrical connector.
3. Remove the two screws and remove the variable blower control.

Installation

Installation is in the reverse order of removal.

REAR VARIABLE BLOWER CONTROL

Removal

1. Remove the rear heater and cooling unit assembly. Refer to [VTL-17, "Removal and Installation"](#).
2. Disconnect the rear variable blower control electrical connector.
3. Remove the two screws and remove the rear variable blower control.

Installation

Installation is in the reverse order of removal.

HEATER & COOLING UNIT ASSEMBLY

< REMOVAL AND INSTALLATION >

HEATER & COOLING UNIT ASSEMBLY

Component

INFOID:000000008632167

Front A/C System

SEC. 270 • 274 • 276

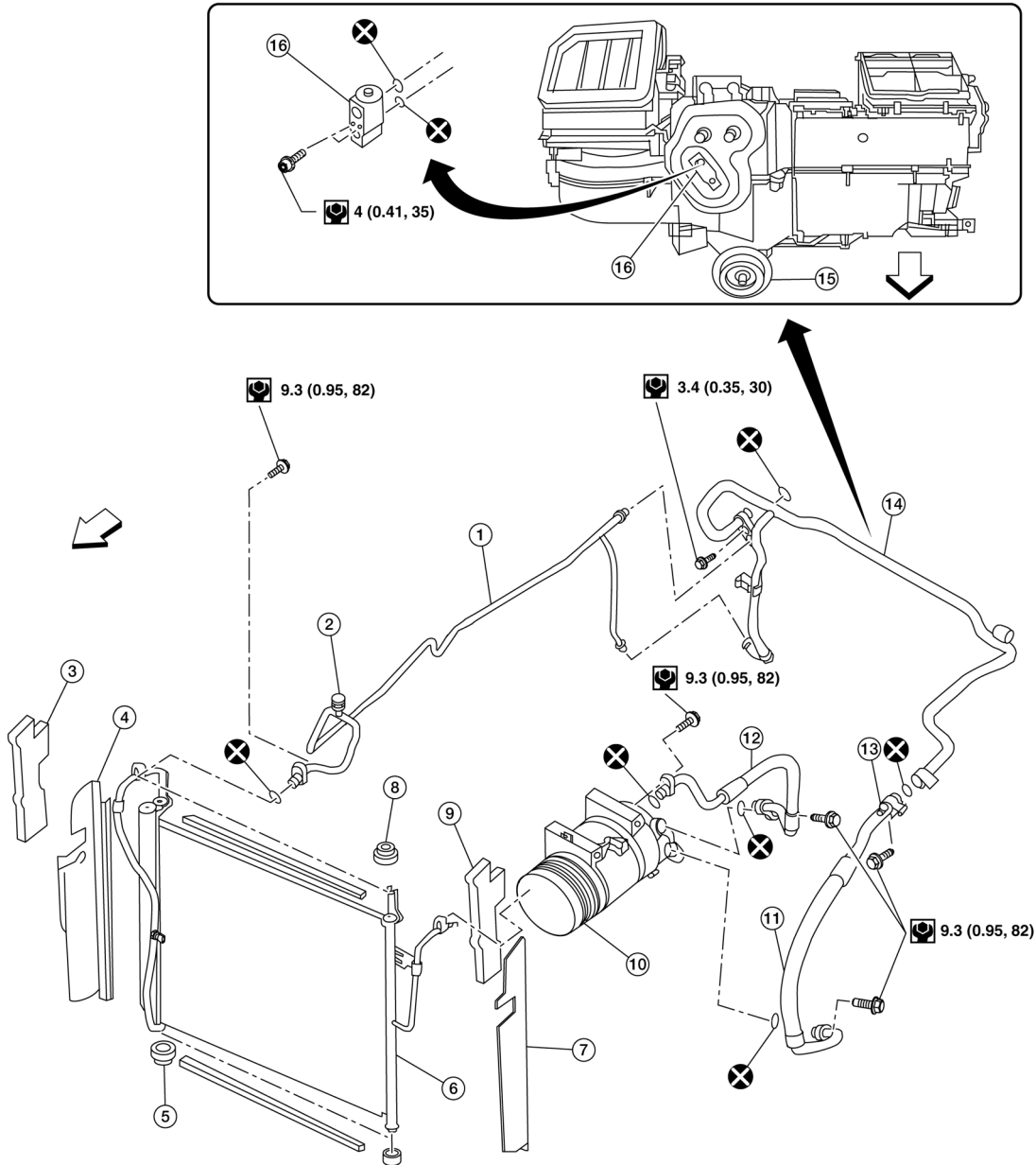

- 1. High-pressure pipe
- 4. Condenser seal RH

- 2. High-pressure service valve
- 5. Grommet

- 3. Side seal RH
- 6. Condenser and liquid tank assembly (with refrigerant pressure sensor)

AWIIA1594GB

HEATER & COOLING UNIT ASSEMBLY

< REMOVAL AND INSTALLATION >

- | | | |
|--------------------------------|--------------------------------|---------------------------------|
| 7. Condenser seal LH | 8. Grommet | 9. Side seal LH |
| 10. Compressor | 11. Low-pressure flexible hose | 12. High-pressure flexible hose |
| 13. Low-pressure service valve | 14. Low-pressure pipe | 15. Drain tube |
| 16. Front expansion valve | ↔ Front | |

Rear A/C System

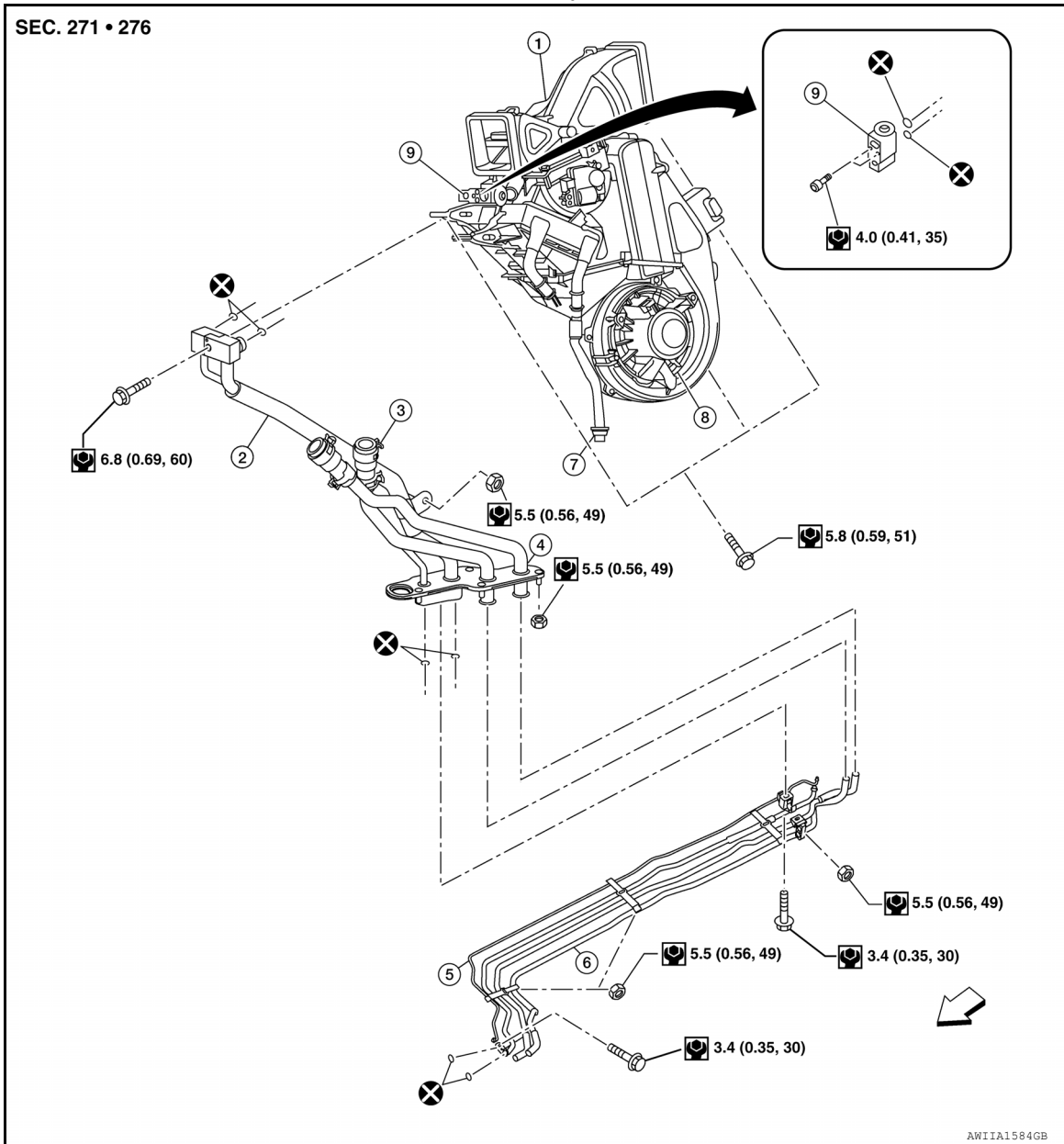

- | | | |
|--|------------------------------|--------------------------------------|
| 1. Rear heater and cooling unit assembly | 2. Rear A/C pipes | 3. Rear heater core hose |
| 4. Rear heater core pipes | 5. Underfloor rear A/C pipes | 6. Underfloor rear heater core pipes |
| 7. Drain tube | 8. Rear blower motor | 9. Rear expansion valve |

↔ Front

NOTE:
Refer to [HA-5, "Precaution for Refrigerant Connection"](#).

Removal and Installation

INFOID:000000008632168

FRONT HEATER AND COOLING UNIT ASSEMBLY

Removal

A
B
C
D
E
F
G
H
VTL
J
K
L
M
N
O
P

HEATER & COOLING UNIT ASSEMBLY

< REMOVAL AND INSTALLATION >

1. Move the two front seats to the rear most position on the seat track.
2. Disconnect the battery negative terminal and battery positive terminal.
3. Discharge the refrigerant from the A/C system. Refer to [HA-20, "HFC-134a \(R-134a\) Service Procedure"](#).
4. Drain the coolant from the engine cooling system. Refer to [CO-11, "Changing Engine Coolant"](#).
5. Disconnect the front heater hoses from the front heater core.
6. Disconnect the high/low pressure pipes from the front expansion valve.
7. Remove the instrument panel and console panel. Refer to [IP-12, "Removal and Installation"](#).
8. Disconnect the instrument panel wire harness at the RH and LH in-line connector brackets, and the fuse block (J/B) electrical connectors. Refer to [PG-73, "Terminal Arrangement"](#).
9. Disconnect the steering member from each side of the vehicle body.
10. Remove the front heater and cooling unit assembly with it attached to the steering member from vehicle.

CAUTION:

Use care not to damage the seats and interior trim panels when removing the front heater and cooling unit assembly with it attached to the steering member.

11. Remove the front heater and cooling unit assembly from the steering member.

Installation

Installation is in the reverse order of removal.

- Fill the engine cooling system with the specified coolant mixture. Refer to [CO-11, "Changing Engine Coolant"](#).
- Recharge the A/C system. Refer to [HA-20, "HFC-134a \(R-134a\) Service Procedure"](#).

CAUTION:

- **Do not reuse O-rings.**
- **Apply A/C oil to the O-ring of the low-pressure pipe and high-pressure pipe for installation.**
- **After charging the refrigerant, check for leaks.**

REAR HEATER AND COOLING UNIT ASSEMBLY

Removal

1. Discharge the refrigerant from the A/C system. Refer to [HA-20, "HFC-134a \(R-134a\) Service Procedure"](#).
2. Drain the coolant from the engine cooling system. Refer to [CO-11, "Changing Engine Coolant"](#).
3. Remove the luggage side finisher lower and upper RH. Refer to [INT-18, "Removal and Installation"](#).
4. Disconnect the rear heater core hoses from the rear heater core.
5. Disconnect the rear A/C pipes from the rear expansion valve.
6. Disconnect the following electrical connectors:
 - Rear blower motor
 - Rear variable blower control
 - Rear air mix door motor
 - Rear mode door motor
7. Disconnect the ducts and drain tube from the rear heater and cooling unit assembly.
8. Remove the rear heater and cooling unit assembly.

Installation

Installation is in the reverse order of removal.

CAUTION:

- **Do not reuse O-rings.**
- **Apply A/C oil to the O-ring of the low-pressure pipe and high-pressure pipe for installation**
- **After charging the refrigerant, check for leaks.**

NOTE:

- Fill the engine cooling system with the specified coolant mixture. Refer to [CO-11, "Changing Engine Coolant"](#).
- Recharge the A/C system. Refer to [HA-20, "HFC-134a \(R-134a\) Service Procedure"](#).

EVAPORATOR

< REMOVAL AND INSTALLATION >

EVAPORATOR

Removal and Installation for Front Evaporator and Expansion Valve

INFOID:000000008632169

REMOVAL

1. Discharge the refrigerant. Refer to [HA-20, "HFC-134a \(R-134a\) Service Procedure"](#).
2. Remove the front heater core. Refer to [VTL-24, "Removal and Installation"](#).
3. Remove the defroster mode door arm.
4. Separate the upper heater and cooling unit case from the lower heater and cooling unit case.
5. Remove the evaporator and expansion valve assembly.
6. Remove the cooler grommet.

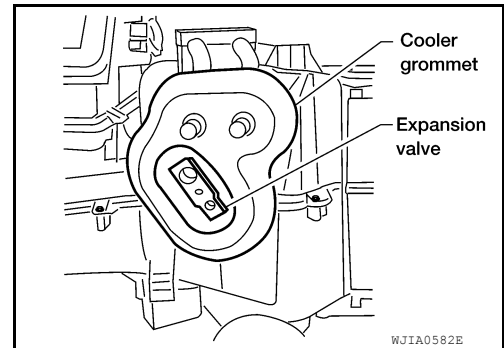

INSTALLATION

Installation is in the reverse order of removal.

Expansion valve bolts : 4 N·m (0.41 kg-m, 35 in-lb)

A/C refrigerant pipe to expansion valve bolt : Refer to [HA-29, "Component"](#).

CAUTION:

- Do reuse O-rings.
- Apply compressor oil to the new O-rings for installation.
- After charging refrigerant, check for leaks.

A
B
C
D
E
F
G
H
VTL
J
K
L
M
N
O
P

EVAPORATOR

< REMOVAL AND INSTALLATION >

Removal and Installation for Rear Evaporator

INFOID:000000008632170

Rear Heater and Cooling Unit Assembly

SEC. 274

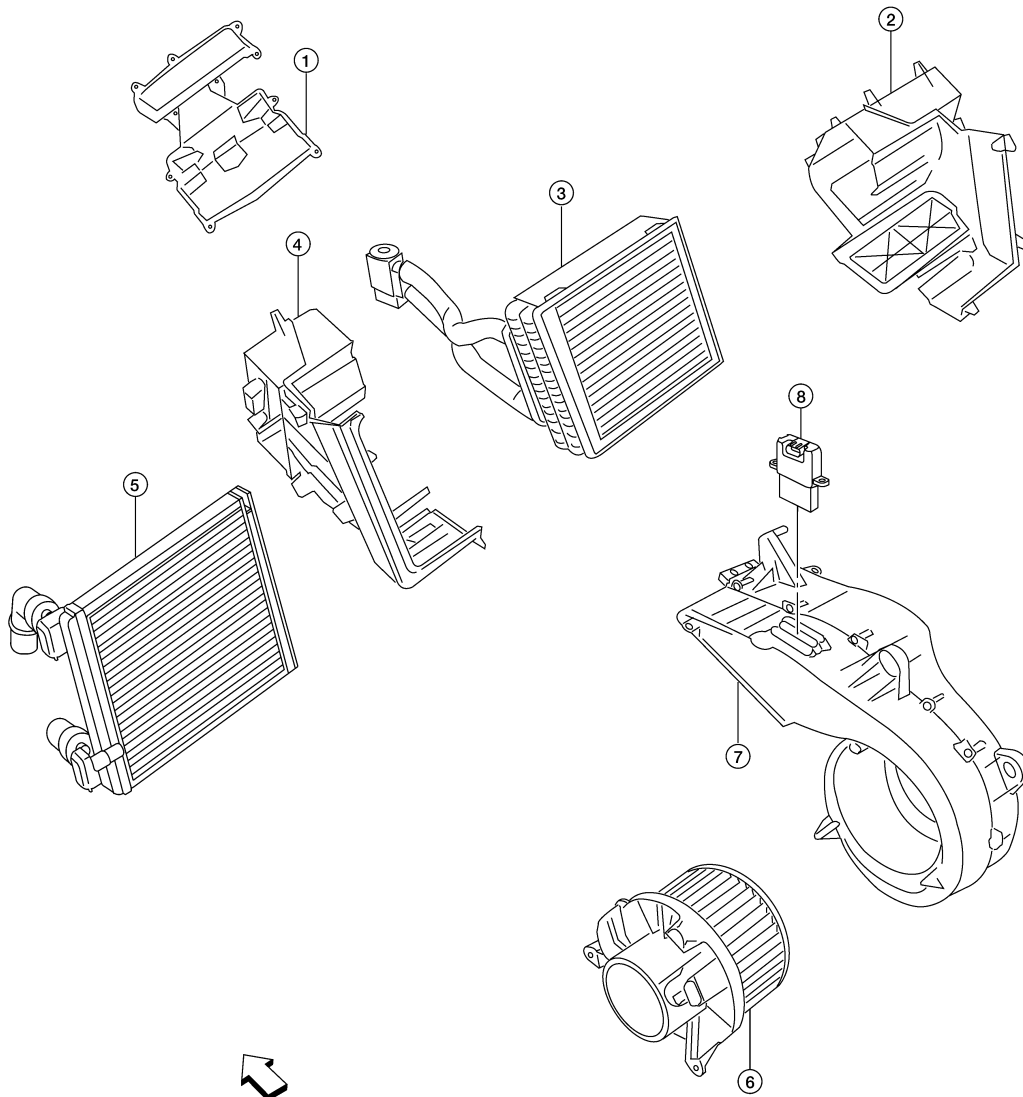

AWIIA00872Z

- | | | |
|----------------------|------------------------------------|-----------------|
| 1. Front cover | 2. Evaporator and heater core case | 3. Evaporator |
| 4. Side cover | 5. Heater core | 6. Blower motor |
| 7. Blower motor case | 8. Variable blower control | |
- ⇐ Front

REMOVAL

1. Remove the rear heater and cooling unit assembly from the vehicle. Refer to [VTL-17, "Removal and Installation"](#).
2. Remove the blower motor.
3. Remove the variable blower control.
4. Remove the air mix door motor.
5. Remove the mode door motor.
6. Remove the rear duct and mode door assembly. Refer to [VTL-36, "Removal and Installation"](#).
7. Disassemble the rear heater and cooling unit assembly to remove the evaporator.

EVAPORATOR

< REMOVAL AND INSTALLATION >

INSTALLATION

Installation is in the reverse order of removal.

CAUTION:

- Do not reuse O-rings.
- Apply compressor oil to the new O-rings for installation.
- After charging the refrigerant, check for leaks.

A

B

C

D

E

F

G

H

VTL

J

K

L

M

N

O

P

EXPANSION VALVE

< REMOVAL AND INSTALLATION >

EXPANSION VALVE

Removal and Installation for Front Expansion Valve

INFOID:000000008632171

REMOVAL AND INSTALLATION

For removal and installation of the front expansion valve, refer to [HA-48, "Removal and Installation - Front Expansion Valve"](#).

Removal and Installation for Rear Expansion Valve

INFOID:000000008632172

REMOVAL AND INSTALLATION

For removal and installation of the rear expansion valve, refer to [HA-48, "Removal and Installation - Rear Expansion Valve"](#).

HEATER CORE

< REMOVAL AND INSTALLATION >

HEATER CORE

Component

INFOID:000000008632173

Front Heater and Cooling Unit Assembly

SEC. 271

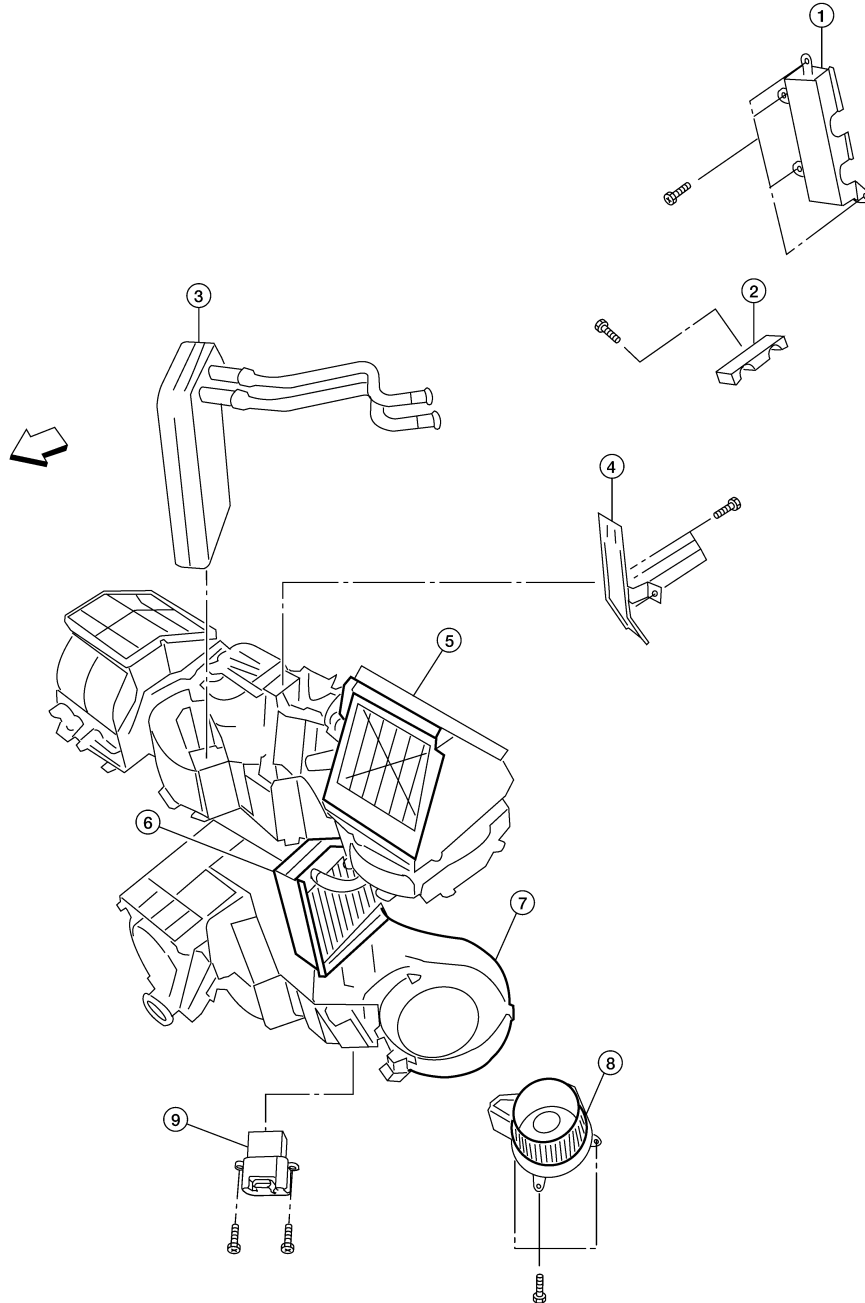

A
B
C
D
E
F
G
H
VTL
J
K
L
M
N
O
P

- | | | |
|---------------------------------------|---------------------------------------|--|
| 1. Heater core cover | 2. Heater core pipe bracket | 3. Heater core |
| 4. Upper bracket | 5. Upper heater and cooling unit case | 6. Evaporator and expansion valve assembly |
| 7. Lower heater and cooling unit case | 8. Blower motor | 9. Variable blower control |

← Front

AW1IA00862Z

HEATER CORE

< REMOVAL AND INSTALLATION >

Rear Heater and Cooling Unit Assembly

SEC. 274

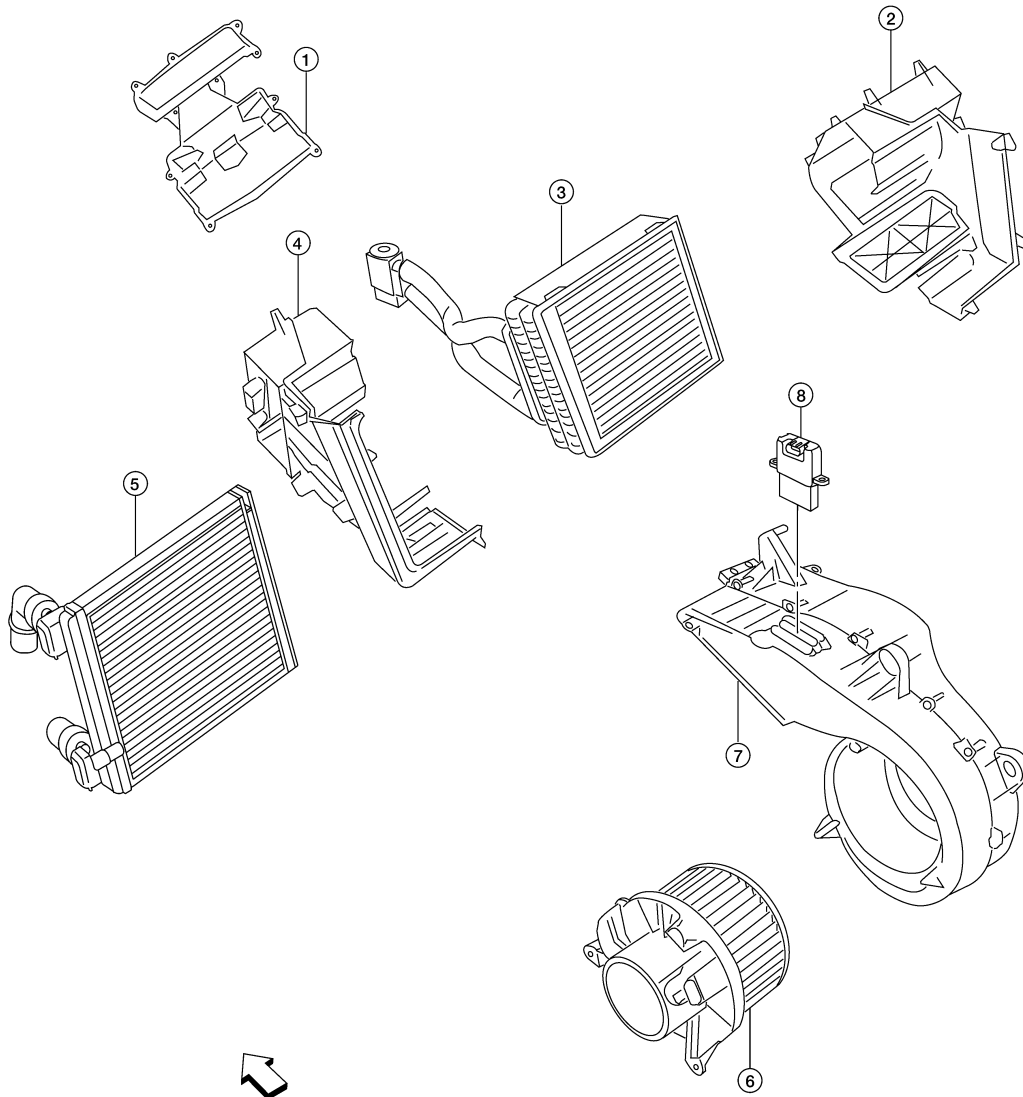

AWIIA0087ZZ

- | | | |
|----------------------|------------------------------------|-----------------|
| 1. Front cover | 2. Evaporator and heater core case | 3. Evaporator |
| 4. Side cover | 5. Heater core | 6. Blower motor |
| 7. Blower motor case | 8. Variable blower control | |

⇐ Front

Removal and Installation

INFOID:000000008632174

FRONT HEATER CORE

Removal

1. Remove the front heater and cooling unit assembly. Refer to [VTL-17. "Removal and Installation"](#).
2. Remove the four screws and remove the upper bracket.
3. Remove the four screws and remove the heater core cover.
4. Remove the heater core pipe bracket.

HEATER CORE

< REMOVAL AND INSTALLATION >

5. Remove the heater core.

NOTE:

If equipped and the in-cabin microfilters are contaminated from coolant leaking from the heater core, replace the in-cabin microfilters with new ones before installing the new heater core.

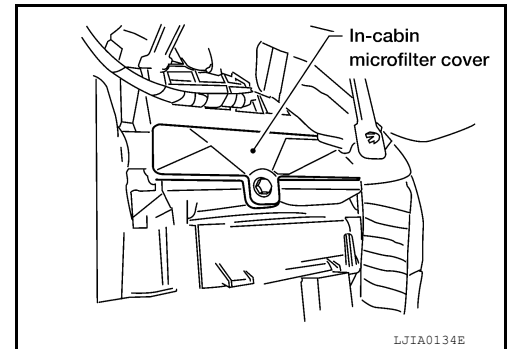

Installation

Installation is in the reverse order of removal.

REAR HEATER CORE

Removal

1. Remove the rear heater and cooling unit assembly. Refer to [VTL-17, "Removal and Installation"](#).
2. Remove the heater core.

Installation

Installation is in the reverse order of removal.

A
B
C
D
E
F
G
H
J
K
L
M
N
O
P

VTL

DEFROSTER DOOR MOTOR

< REMOVAL AND INSTALLATION >

DEFROSTER DOOR MOTOR

Removal and Installation

INFOID:000000008632175

Defroster Door Motor - Front Heater and Cooling Unit Assembly

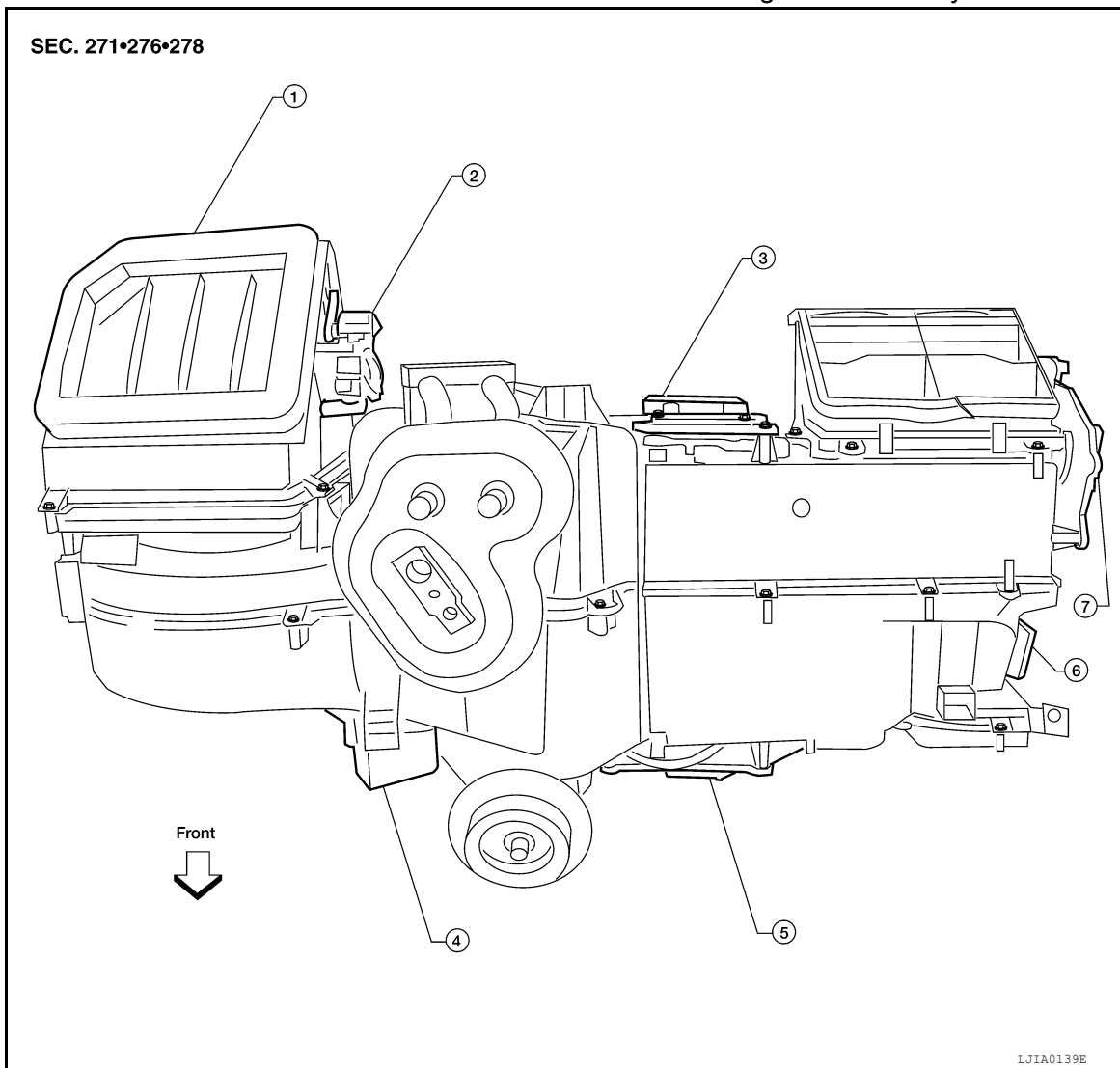

- | | | |
|---|-----------------------------------|--------------------------------|
| 1. Front heater and cooling unit assembly | 2. Intake door motor | 3. Air mix door motor (driver) |
| 4. Variable blower control | 5. Air mix door motor (passenger) | 6. Mode door motor |
| 7. Defroster door motor | | |

REMOVAL

1. Remove the lower knee protector.
2. Remove the accelerator pedal. Refer to [ACC-4, "Removal and Installation"](#).
3. Remove the BCM. Refer to [BCS-54, "Removal and Installation"](#).
4. Remove the Bose speaker amplifier (if equipped). Refer to [AV-274, "Removal and Installation"](#).
5. Disconnect the defroster door motor electrical connector.
6. Remove the three screws and remove the defroster door motor.

INSTALLATION

Installation is in the reverse order of removal.

INTAKE DOOR MOTOR

< REMOVAL AND INSTALLATION >

INTAKE DOOR MOTOR

Removal and Installation

INFOID:000000008632176

Intake Door Motor - Front Heater and Cooling Unit Assembly

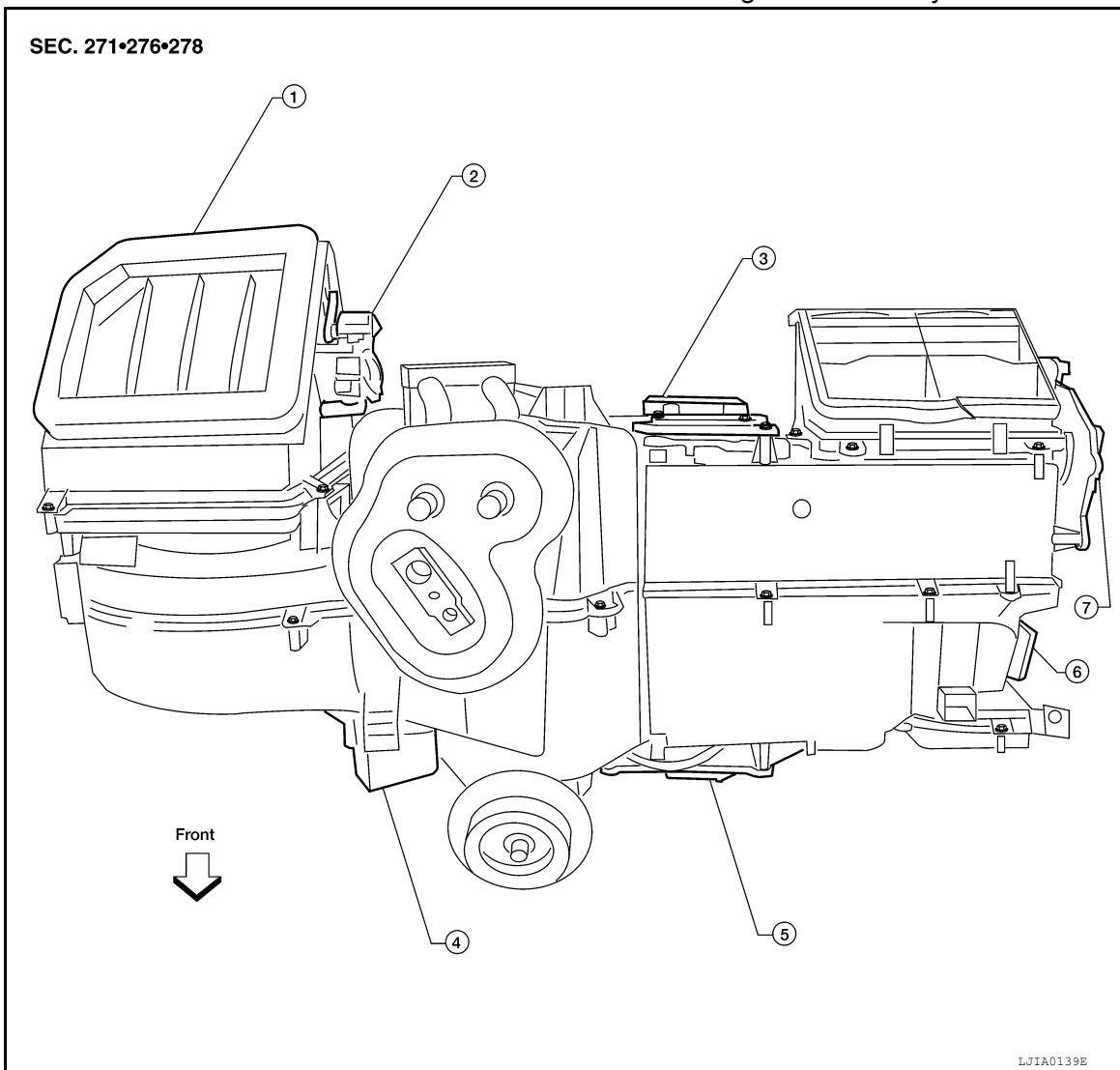

- | | | |
|---|-----------------------------------|--------------------------------|
| 1. Front heater and cooling unit assembly | 2. Intake door motor | 3. Air mix door motor (driver) |
| 4. Variable blower control | 5. Air mix door motor (passenger) | 6. Mode door motor |
| 7. Defroster door motor | | |

REMOVAL

1. Remove the front heater and cooling unit assembly. Refer to [VTL-17, "Removal and Installation"](#).
2. Remove the steering member from the front heater and cooling unit assembly.
3. Disconnect the intake door motor electrical connector.
4. Remove the three screws and remove the intake door motor.

INSTALLATION

Installation is in the reverse order of removal.

MODE DOOR MOTOR

< REMOVAL AND INSTALLATION >

MODE DOOR MOTOR

Components

INFOID:000000008632177

Front Mode Door Motor - Front Heater and Cooling Unit Assembly

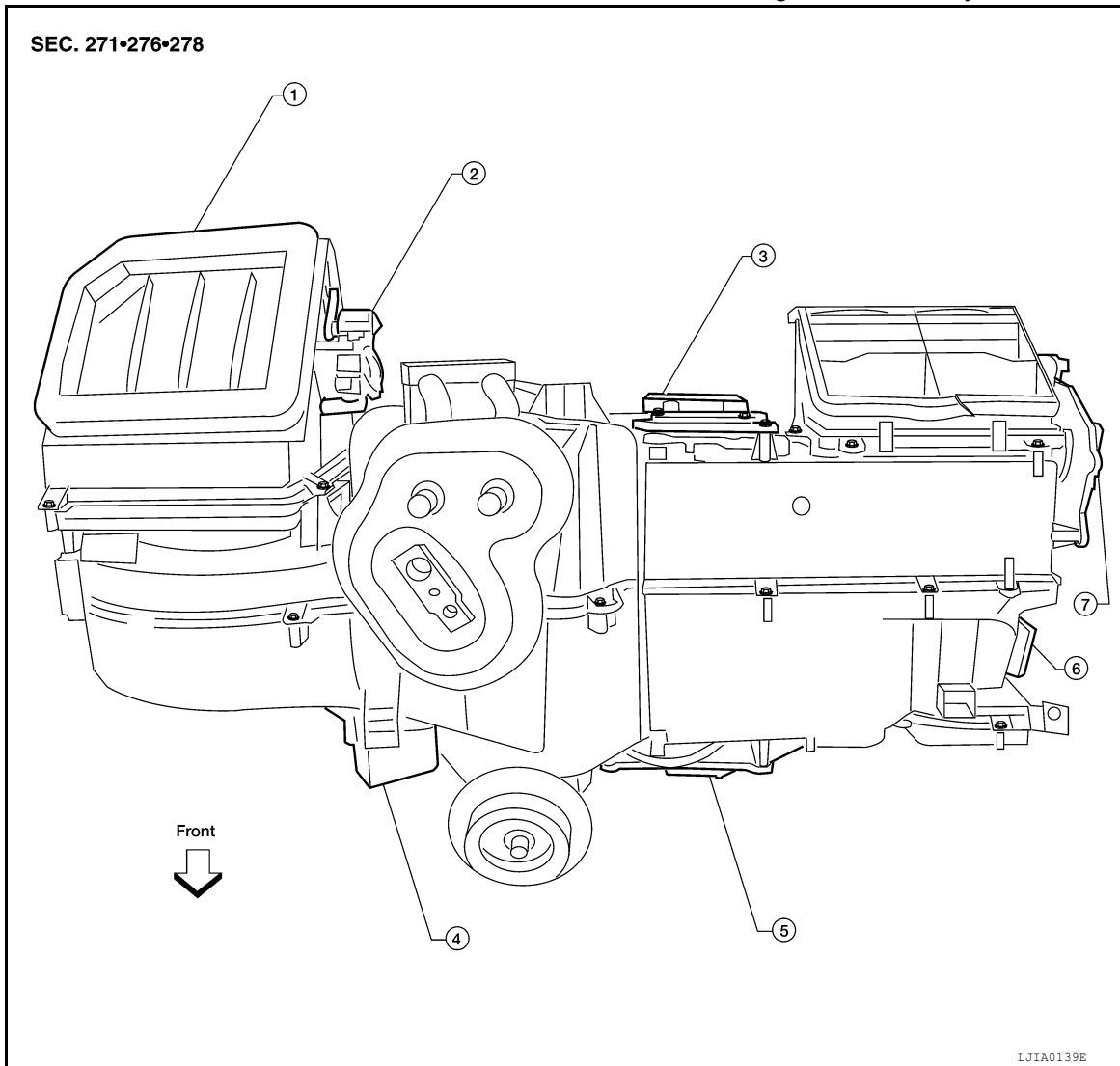

- | | | |
|---|-----------------------------------|--------------------------------|
| 1. Front heater and cooling unit assembly | 2. Intake door motor | 3. Air mix door motor (driver) |
| 4. Variable blower control | 5. Air mix door motor (passenger) | 6. Front mode door motor |
| 7. Defroster door motor | | |

MODE DOOR MOTOR

< REMOVAL AND INSTALLATION >

Rear Mode Door Motor - Rear Heater and Cooling Unit Assembly

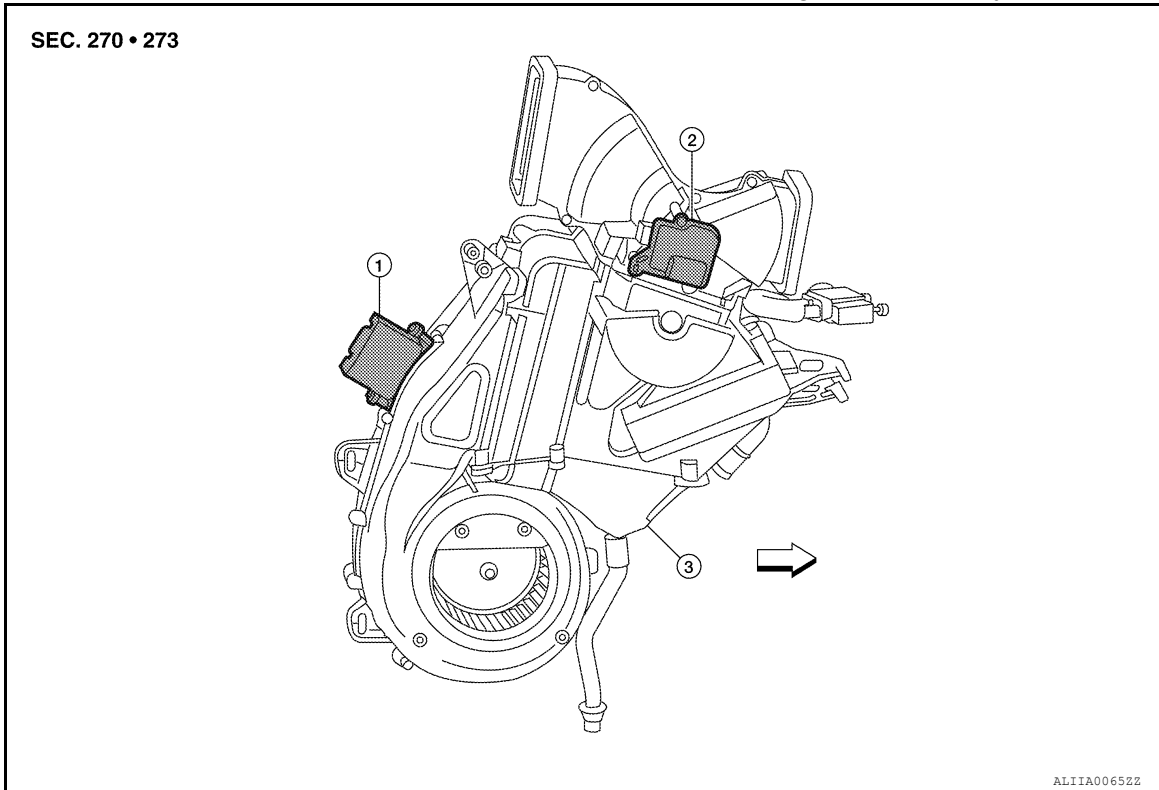

1. Variable blower control

2. Rear mode door motor

3. Rear heater and cooling unit assembly

⇐ Front

VTL

Removal and Installation

INFOID:000000008632178

FRONT MODE DOOR MOTOR

Removal

1. Remove the center console lower cover LH. Refer to [IP-12. "Removal and Installation"](#).
2. Disconnect the front mode door motor connector.
3. Remove the two screws and remove the front mode door motor.

Installation

Installation is in the reverse order of removal.

REAR MODE DOOR MOTOR

Removal

1. Remove the rear heater and cooling unit assembly. Refer to [VTL-17. "Removal and Installation"](#).
2. Disconnect the rear mode door motor connector.
3. Remove the two screws and remove rear mode door motor.

Installation

Installation is in the reverse order of removal.

AIR MIX DOOR MOTOR

< REMOVAL AND INSTALLATION >

AIR MIX DOOR MOTOR

Component

INFOID:000000008632179

Front Air Mix Door Motors - Front Heater and Cooling Unit Assembly

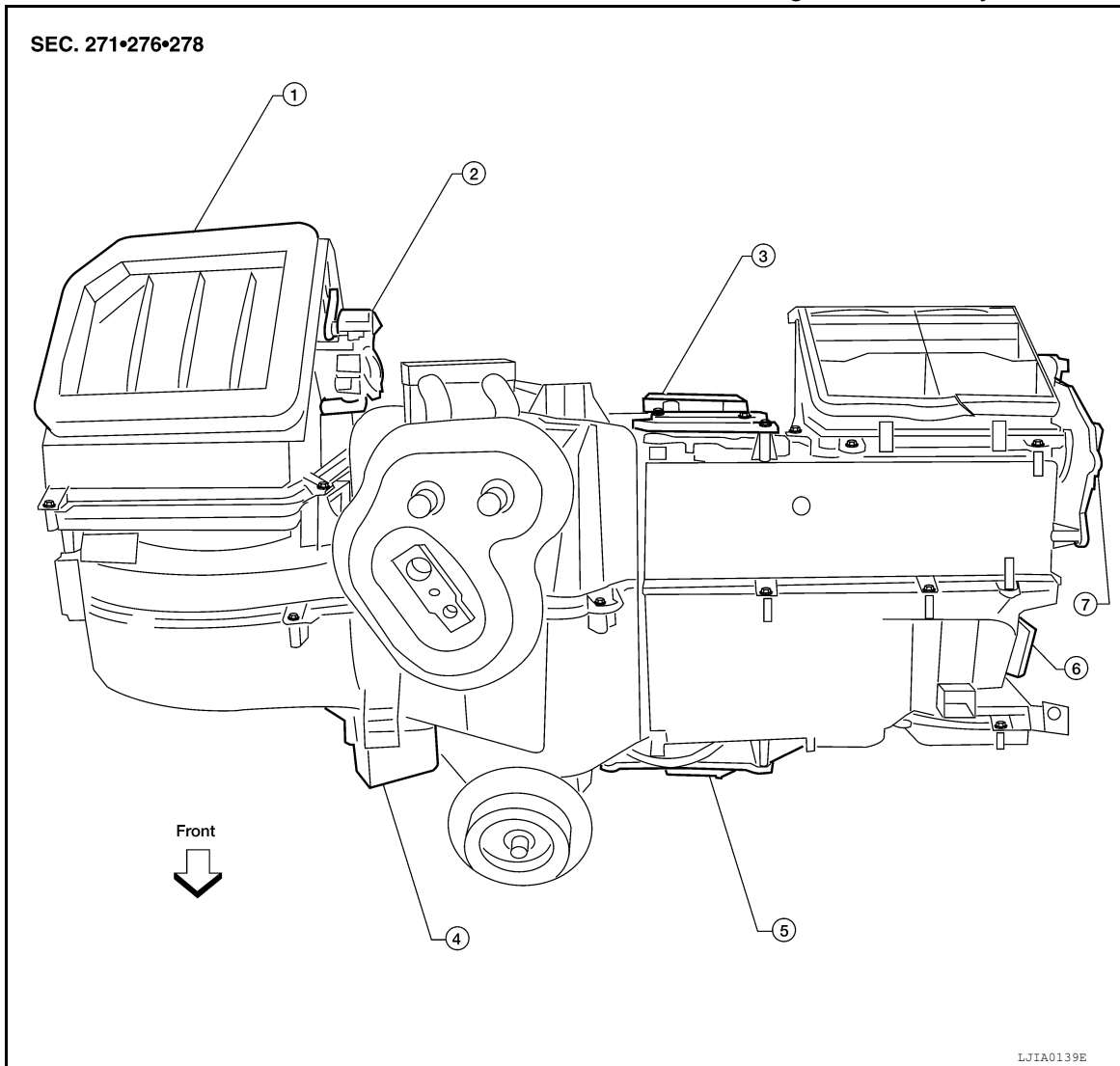

1. Front heater and cooling unit assembly
2. Intake door motor
3. Front air mix door motor (driver)
4. Variable blower control
5. Front air mix door motor (passenger)
6. Front mode door motor
7. Defroster door motor

AIR MIX DOOR MOTOR

< REMOVAL AND INSTALLATION >

Rear Air Mix Door Motor - Rear Heater and Cooling Unit Assembly

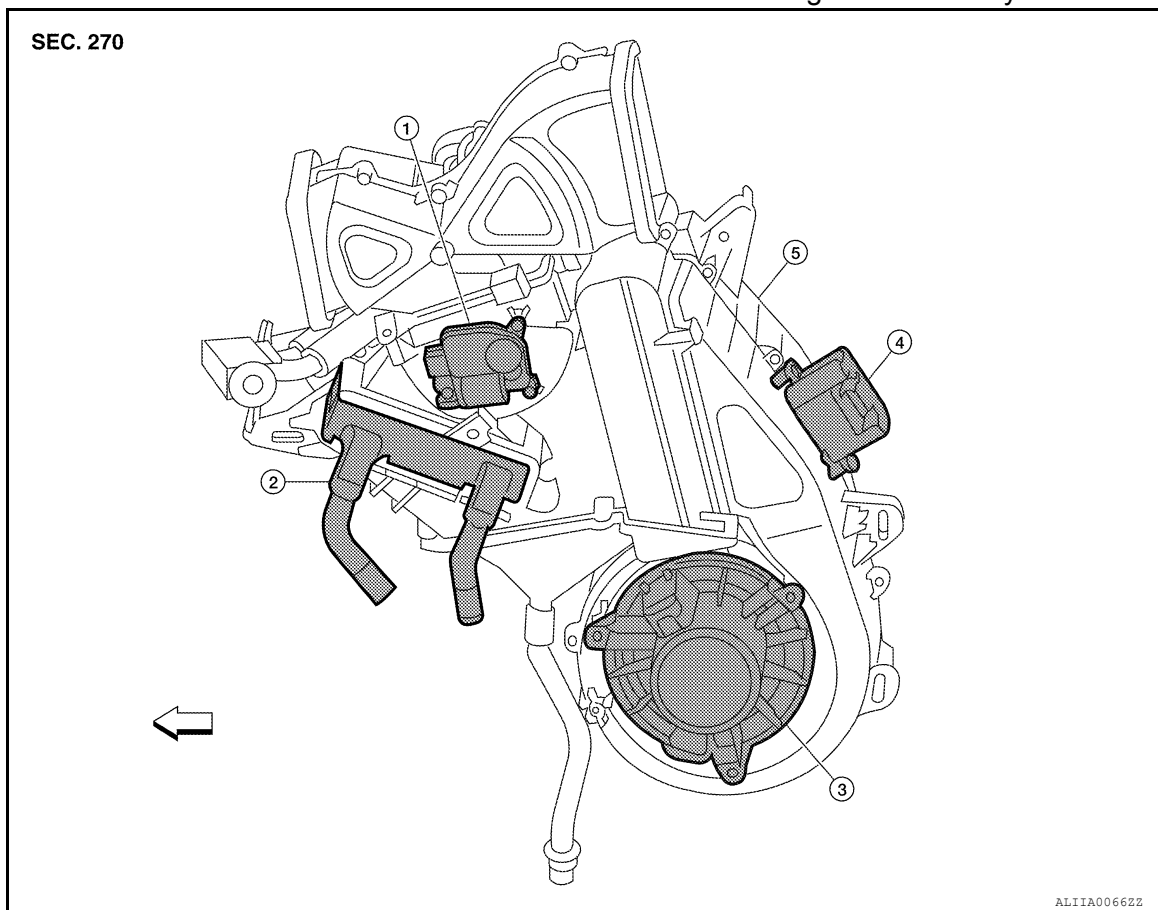

- | | | |
|----------------------------|--|-----------------|
| 1. Rear air mix door motor | 2. Heater core | 3. Blower motor |
| 4. Variable blower control | 5. Rear heater and cooling unit assembly | ↩ Front |

Removal and Installation

INFOID:000000008632180

FRONT AIR MIX DOOR MOTOR (DRIVER)

Removal

1. Remove the instrument panel assembly. Refer to [IP-12, "Removal and Installation"](#).
2. Remove the RH side demister duct and RH ventilator duct. Refer to [VTL-33, "Component"](#).
3. Disconnect the front air mix door motor (driver) electrical connector.
4. Remove the three screws and remove the front air mix door motor.

Installation

Installation is in the reverse order of removal.

FRONT AIR MIX DOOR MOTOR (PASSENGER)

Removal

1. Remove the console cover RH. Refer to [IP-20, "Exploded View"](#).
2. Position the floor carpet aside.
3. Disconnect the front air mix door motor (passenger) electrical connector.
4. Remove the three screws and remove the front air mix door motor.

Installation

Installation is in the reverse order of removal.

REAR AIR MIX DOOR MOTOR

Removal

AIR MIX DOOR MOTOR

< REMOVAL AND INSTALLATION >

1. Remove the luggage side lower finisher RH. Refer to [INT-18. "Removal and Installation"](#).
2. Disconnect the rear air mix door motor electrical connector.
3. Remove the three screws and remove the rear air mix door motor.

Installation

Installation is in the reverse order of removal.

DUCTS AND GRILLES

< REMOVAL AND INSTALLATION >

DUCTS AND GRILLES

Component

INFOID:000000008632181

Ducts - Front Heater and Cooling Unit Assembly

SEC. 270 • 271

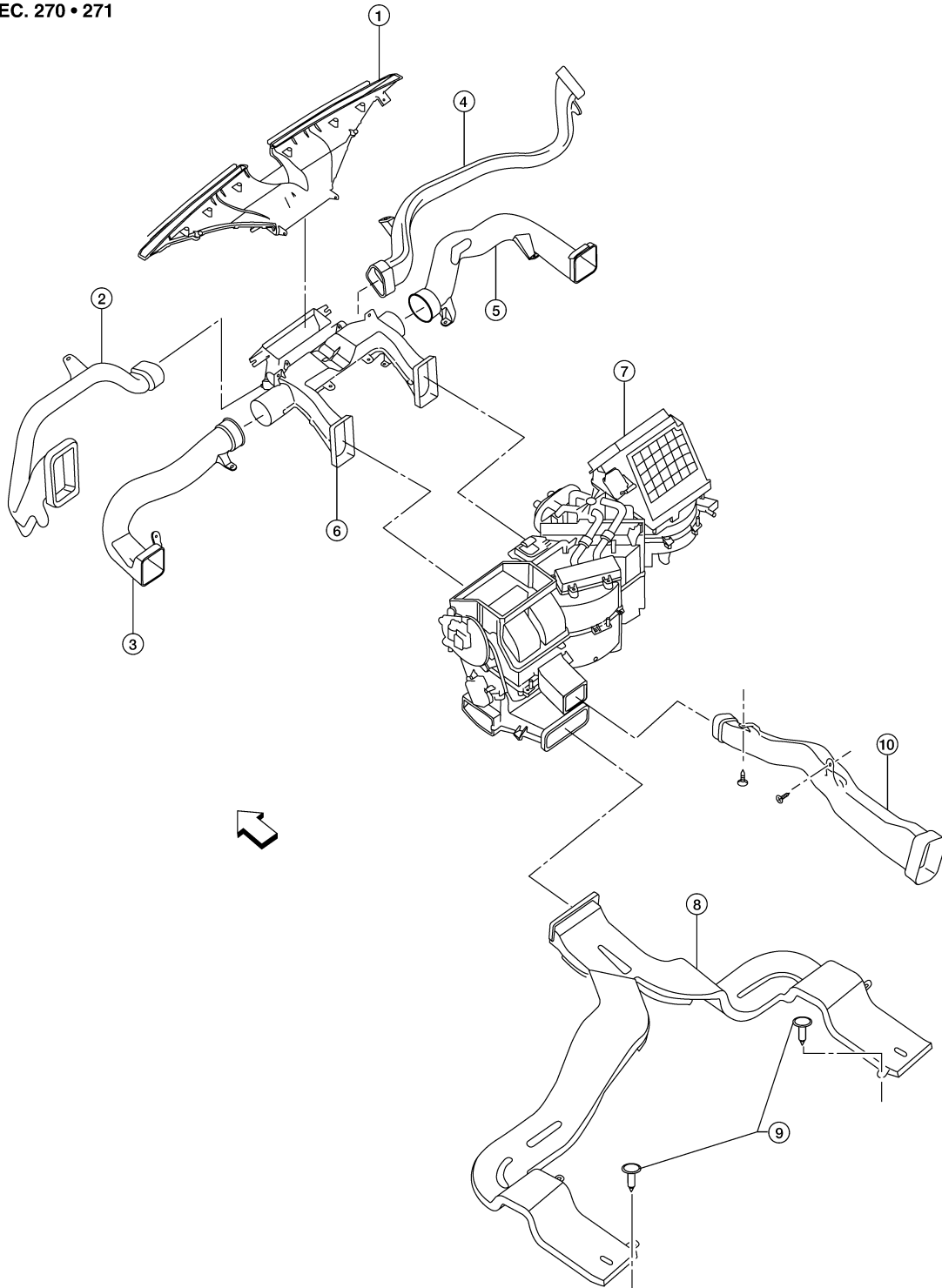

- 1. Defroster nozzle
- 4. RH side demister duct

- 2. LH side demister duct
- 5. RH ventilator duct

- 3. LH ventilator duct
- 6. Center ventilator duct

AWIIA00902Z

A
B
C
D
E
F
G
H
VTL
J
K
L
M
N
O
P

DUCTS AND GRILLES

< REMOVAL AND INSTALLATION >

- 7. Front heater and cooling unit assembly
 - 8. Floor duct
 - 9. Clips
 - 10. Heat duct
- ↩ Front

Ducts - Rear Heater and Cooling Unit Assembly

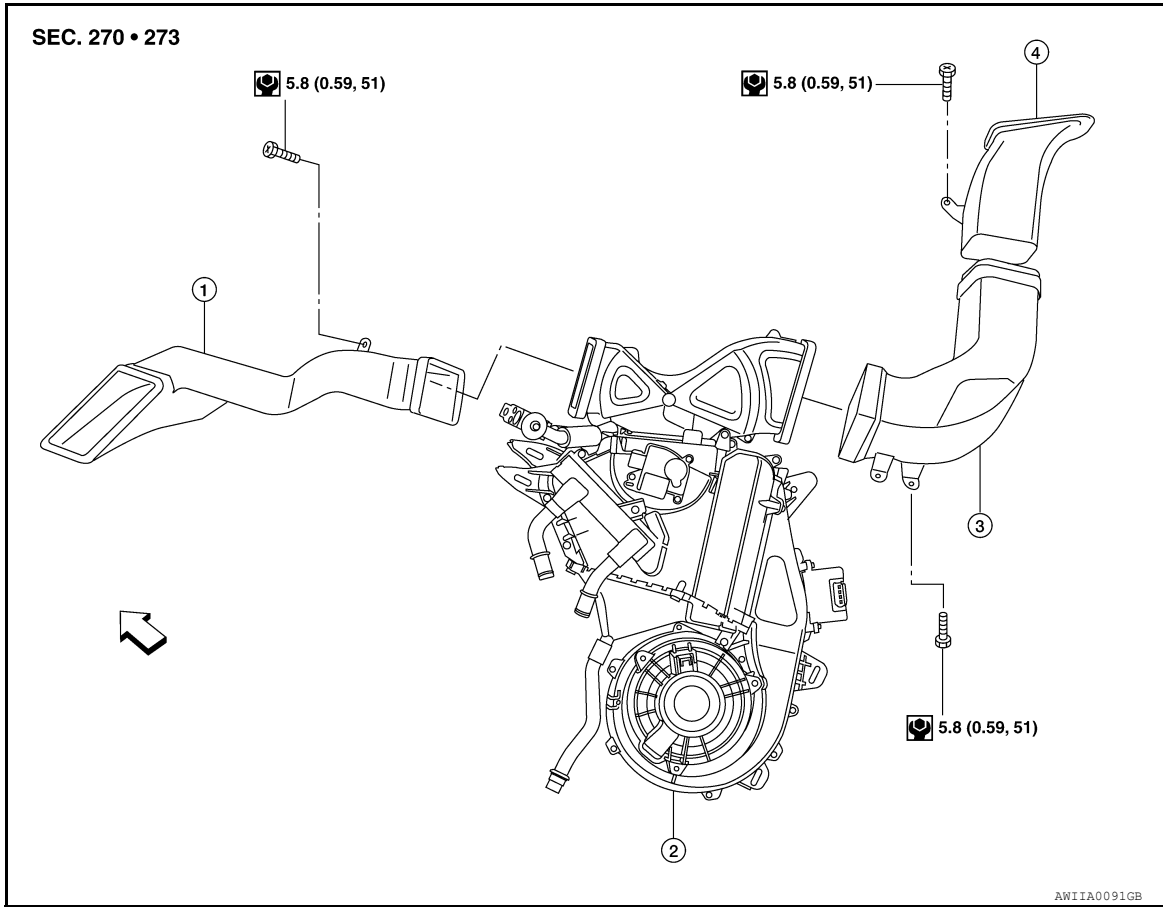

- 1. Rear floor duct
 - 2. Rear heater and cooling unit assembly
 - 3. Rear lower overhead duct
 - 4. Rear upper overhead duct
- ↩ Front

DUCTS AND GRILLES

< REMOVAL AND INSTALLATION >

Grilles

SEC. 685 • 970

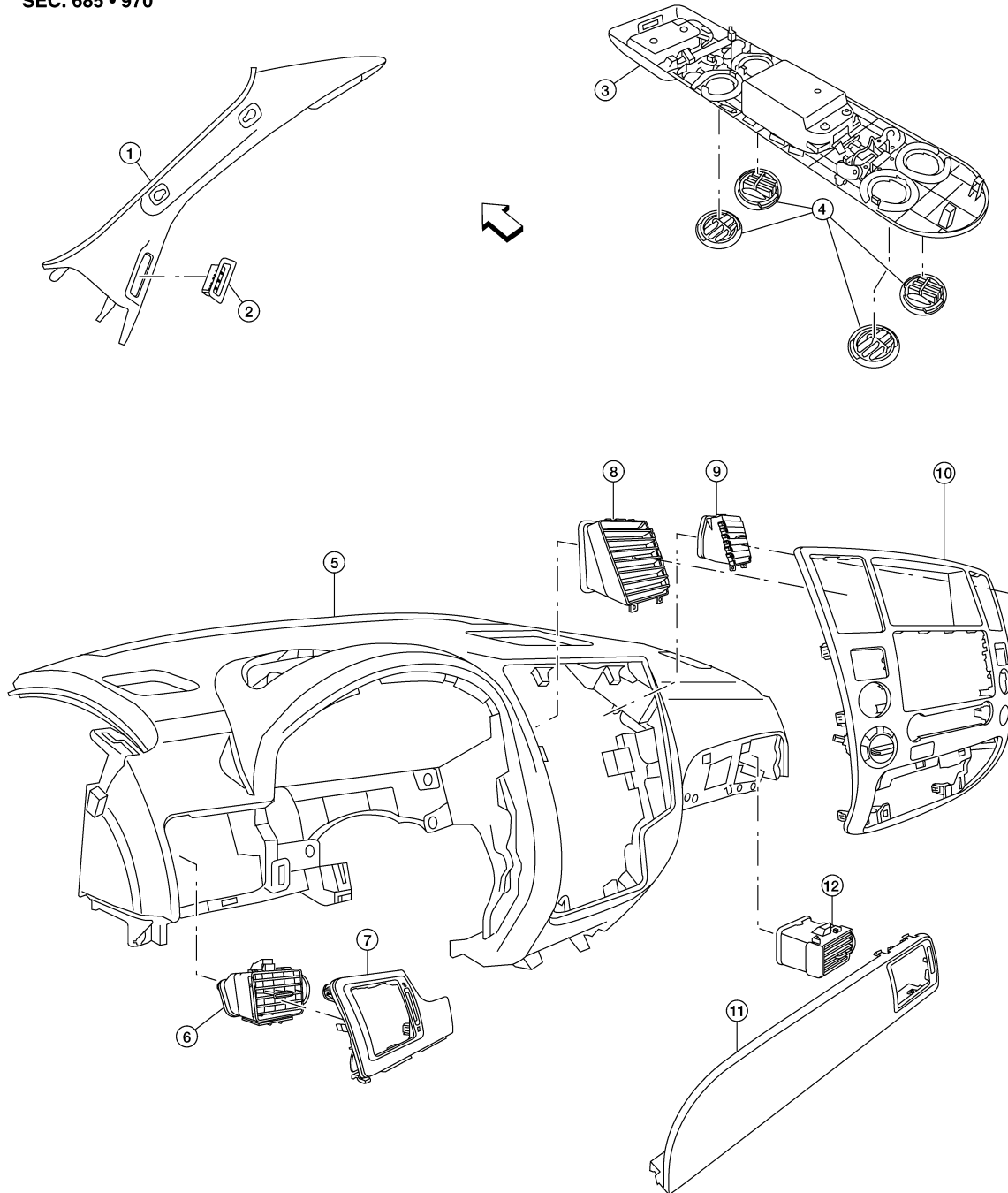

- | | | |
|--|---|----------------------------------|
| 1. Front pillar finisher (RH shown LH similar) | 2. Side demister grille (RH shown LH similar) | 3. Rear roof console |
| 4. Rear roof console grilles | 5. Instrument panel and pad assembly | 6. Side ventilator grille (LH) |
| 7. Instrument upper panel (LH) | 8. Center ventilator grille (LH) | 9. Center ventilator grille (RH) |
| 10. Cluster lid C | 11. Instrument upper panel (RH) | 12. Side ventilator grille (RH) |

← Front

ALIIA00672Z

A
B
C
D
E
F
G
H
VTL
J
K
L
M
N
O
P

DUCTS AND GRILLES

< REMOVAL AND INSTALLATION >

Removal and Installation

INFOID:000000008632182

CENTER CONSOLE HEAT DUCT AND REAR FINISHER ASSEMBLY GRILLE

Removal

The center console must be removed and disassembled to remove the heat duct and rear finisher assembly grille. Refer to [IP-21, "Removal and Installation"](#).

Installation

Installation is in the reverse order of removal.

DEFROSTER NOZZLE

Removal

1. Remove the instrument panel. Refer to [IP-12, "Removal and Installation"](#).
2. Disconnect the instrument panel wire harness at the RH and LH connector brackets.
3. Remove the steering member with heater case.
4. Remove the RH and LH ventilator ducts and the RH and LH demister ducts.
5. Remove the defroster nozzle.

Installation

Installation is in the reverse order of removal.

RH AND LH SIDE DEMISTER DUCT

Removal

1. Remove the instrument panel. Refer to [IP-12, "Removal and Installation"](#).
2. Disconnect the instrument panel wire harness at the RH and LH connector brackets.
3. Remove the steering member with heater case.
4. Remove the RH or LH side demister duct screws.
5. Remove the RH or LH side demister duct.

Installation

Installation is in the reverse order of removal.

RH AND LH VENTILATOR DUCT

Removal

1. Remove the instrument panel. Refer to [IP-12, "Removal and Installation"](#).
2. Disconnect the instrument panel wire harness at the RH and LH connector brackets.
3. Remove the steering member with heater case.
4. Remove the RH or LH ventilator duct.

Installation

Installation is in the reverse order of removal.

CENTER VENTILATOR DUCT

Removal

1. Remove the instrument panel. Refer to [IP-12, "Removal and Installation"](#).
2. Remove the front heater and cooling unit assembly. Refer to [VTL-17, "Removal and Installation"](#).
3. Remove the RH and LH side demister ducts.
4. Remove the RH and LH ventilator ducts.
5. Remove the defroster nozzle.
6. Remove the center ventilator duct.

Installation

Installation is in the reverse order of removal.

FLOOR DUCT

Removal

DUCTS AND GRILLES

< REMOVAL AND INSTALLATION >

1. Remove the floor carpet. Refer to [INT-20, "Removal and Installation"](#).
2. Remove the two clips and remove the floor duct.

Installation

Installation is in the reverse order of removal.

REAR OVERHEAD DUCTS

Removal

1. Remove the luggage side finisher lower RH. Refer to [INT-18, "Removal and Installation"](#).
2. Remove the headlining. Refer to [INT-21, "Removal and Installation"](#).

NOTE:

The rear headlining duct connected to the rear overhead duct is part of the headlining trim panel and is replaced as an assembly.

3. Remove the two bolts and remove the rear upper and lower overhead ducts.

Installation

Installation is in the reverse order of removal.

REAR FLOOR DUCT

Removal

1. Remove the luggage side finisher lower RH. Refer to [INT-18, "Removal and Installation"](#).
2. Reposition the floor carpet out of the way.
3. Remove the two bolts and remove the rear floor duct.

Installation

Installation is in the reverse order of removal.

GRILLES

Removal

1. Remove the interior trim panels as necessary. Refer to [IP-12, "Removal and Installation"](#) or [INT-21, "Removal and Installation"](#).
2. Remove the grille from the interior trim panel.

NOTE:

To remove the rear roof console grilles, turn the grille counter-clockwise to release the grille from the rear roof console.

Installation

Installation is in the reverse order of removal.

A

B

C

D

E

F

G

H

VTL

J

K

L

M

N

O

P