

SECTION **EXT**
EXTERIOR

A
B
C
D
E
F
G
H
I
J
EXT
L
M
N
O
P

CONTENTS

SERVICE INFORMATION	2	Removal and Installation	19
PRECAUTIONS	2	FRONT GRILLE	23
Precaution for Supplemental Restraint System (SRS) "AIR BAG" and "SEAT BELT PRE-TENSIONER"	2	Removal and Installation	23
Precaution Necessary for Steering Wheel Rotation After Battery Disconnect	2	COWL TOP	24
Service Notice	3	Removal and Installation	24
Precaution for Work	3	FRONT FENDER	26
PREPARATION	4	Removal and Installation	26
Special Service Tool	4	FENDER PROTECTOR	27
Commercial Service Tool	4	Removal and Installation	27
CLIP LIST	5	RUNNING BOARDS	29
Descriptions for Clips	5	Removal and Installation	29
SQUEAK AND RATTLE TROUBLE DIAGNOSES	9	REAR SPOILER	30
Work Flow	9	Removal and Installation	30
Generic Squeak and Rattle Troubleshooting	10	ROOF RACK	31
Diagnostic Worksheet	13	Removal and Installation	31
FRONT BUMPER	15	DOOR OUTSIDE MOLDING	32
Removal and Installation	15	Removal and Installation	32
REAR BUMPER	19	SIDE GUARD MOLDING	34
		Removal and Installation	34

PRECAUTIONS

< SERVICE INFORMATION >

SERVICE INFORMATION

PRECAUTIONS

Precaution for Supplemental Restraint System (SRS) "AIR BAG" and "SEAT BELT PRE-TENSIONER"

INFOID:000000011289268

The Supplemental Restraint System such as "AIR BAG" and "SEAT BELT PRE-TENSIONER", used along with a front seat belt, helps to reduce the risk or severity of injury to the driver and front passenger for certain types of collision. This system includes seat belt switch inputs and dual stage front air bag modules. The SRS system uses the seat belt switches to determine the front air bag deployment, and may only deploy one front air bag, depending on the severity of a collision and whether the front occupants are belted or unbelted. Information necessary to service the system safely is included in the SR and SB section of this Service Manual.

WARNING:

- To avoid rendering the SRS inoperative, which could increase the risk of personal injury or death in the event of a collision which would result in air bag inflation, all maintenance must be performed by an authorized NISSAN/INFINITI dealer.
- Improper maintenance, including incorrect removal and installation of the SRS, can lead to personal injury caused by unintentional activation of the system. For removal of Spiral Cable and Air Bag Module, see the SR section.
- Do not use electrical test equipment on any circuit related to the SRS unless instructed to in this Service Manual. SRS wiring harnesses can be identified by yellow and/or orange harnesses or harness connectors.

PRECAUTIONS WHEN USING POWER TOOLS (AIR OR ELECTRIC) AND HAMMERS

WARNING:

- When working near the Airbag Diagnosis Sensor Unit or other Airbag System sensors with the Ignition ON or engine running, DO NOT use air or electric power tools or strike near the sensor(s) with a hammer. Heavy vibration could activate the sensor(s) and deploy the air bag(s), possibly causing serious injury.
- When using air or electric power tools or hammers, always switch the Ignition OFF, disconnect the battery and wait at least three minutes before performing any service.

Precaution Necessary for Steering Wheel Rotation After Battery Disconnect

INFOID:000000011289269

NOTE:

- This Procedure is applied only to models with Intelligent Key system and NATS (NISSAN ANTI-THEFT SYSTEM).
- Remove and install all control units after disconnecting both battery cables with the ignition knob in the "LOCK" position.
- Always use CONSULT to perform self-diagnosis as a part of each function inspection after finishing work. If DTC is detected, perform trouble diagnosis according to self-diagnostic results.

For models equipped with the Intelligent Key system and NATS, an electrically controlled steering lock mechanism is adopted on the key cylinder.

For this reason, if the battery is disconnected or if the battery is discharged, the steering wheel will lock and steering wheel rotation will become impossible.

If steering wheel rotation is required when battery power is interrupted, follow the procedure below before starting the repair operation.

OPERATION PROCEDURE

1. Connect both battery cables.

NOTE:

Supply power using jumper cables if battery is discharged.

2. Use the Intelligent Key or mechanical key to turn the ignition switch to the "ACC" position. At this time, the steering lock will be released.
3. Disconnect both battery cables. The steering lock will remain released and the steering wheel can be rotated.
4. Perform the necessary repair operation.

PRECAUTIONS

< SERVICE INFORMATION >

5. When the repair work is completed, return the ignition switch to the "LOCK" position before connecting the battery cables. (At this time, the steering lock mechanism will engage.)
6. Perform a self-diagnosis check of all control units using CONSULT.

Service Notice

INFOID:000000011289270

- When removing or installing various parts, place a cloth or padding on the vehicle body to prevent scratches.
- Handle trim, molding, instruments, grille, etc. carefully during removing or installing. Be careful not to soil or damage them.
- Apply sealing compound where necessary when installing parts.
- When applying sealing compound, be careful that the sealing compound does not protrude from parts.
- When replacing any metal parts (for example body outer panel, members, etc.), be sure to take rust prevention measures.

Precaution for Work

INFOID:000000011289271

- When removing or disassembling each component, be careful not to damage or deform it. If a component may be subject to interference, be sure to protect it with a shop cloth.
- When removing (disengaging) components with a screwdriver or similar tool, be sure to wrap the component with a shop cloth or vinyl tape to protect it.
- Protect the removed parts with a shop cloth and prevent them from being dropped.
- Replace a deformed or damaged clip.
- If a part is specified as a non-reusable part, always replace it with a new one.
- Be sure to tighten bolts and nuts securely to the specified torque.
- After installation is complete, be sure to check that each part works properly.
- Follow the steps below to clean components:
 - Water soluble dirt:
 - Dip a soft cloth into lukewarm water, wring the water out of the cloth and wipe the dirty area.
 - Then rub with a soft, dry cloth.
 - Oily dirt:
 - Dip a soft cloth into lukewarm water with mild detergent (concentration: within 2 to 3%) and wipe the dirty area.
 - Then dip a cloth into fresh water, wring the water out of the cloth and wipe the detergent off.
 - Then rub with a soft, dry cloth.
 - Do not use organic solvent such as thinner, benzene, alcohol or gasoline.
 - For genuine leather seats, use a genuine leather seat cleaner.

A
B
C
D
E
F
G
H
I
J
L
M
N
O
P

EXT

PREPARATION

< SERVICE INFORMATION >

PREPARATION

Special Service Tool

INFOID:000000011289272

The actual shape of the tools may differ from those illustrated here.

Tool number (TechMate No.) Tool name	Description
— (J-39570) Chassis Ear	Locating the noise
— (J-46534) Trim Tool Set	Removing trim components
— (J-50397) NISSAN Squeak and Rattle kit	Repairing the cause of noise

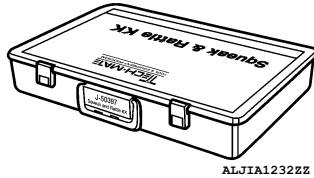
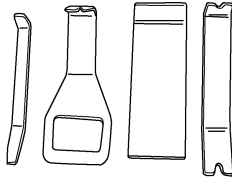
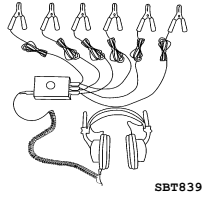

Commercial Service Tool

INFOID:000000011289273

(TechMate No.) Tool name	Description
(J-39565) Engine Ear	Locating the noise

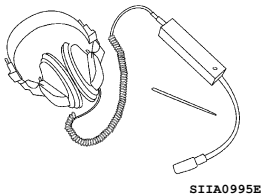

CLIP LIST







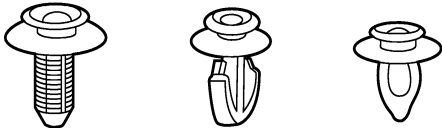

< SERVICE INFORMATION >

CLIP LIST

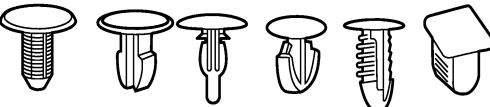
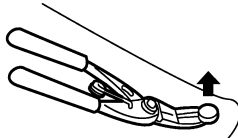
Descriptions for Clips

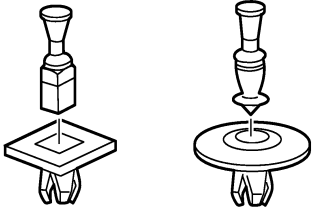
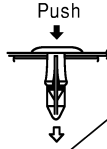
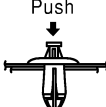
INFOID:000000011289274

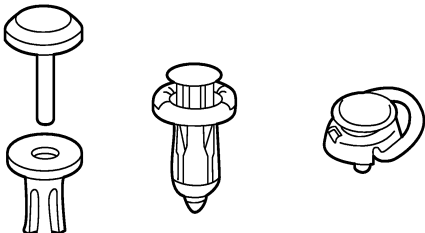
Replace any clips which are damaged during removal or installation.

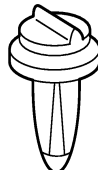
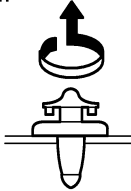





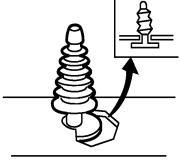
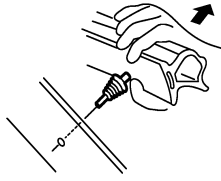

Symbol No.	Shapes	Removal & Installation
C101 		<p>Removal: Remove by bending up with flat-bladed screwdrivers or clip remover.</p> 
C103 		 <p>Removal: Remove with a clip remover.</p>
C203 		<p>Removal: Push center pin to catching position. (Do not remove center pin by hitting it.)</p> <p>Push</p>  <p>Installation:</p> <p>Push</p> 
C205 		<p>Removal: Flat-bladed screwdriver</p>  <p>Clip</p> <p>Finisher</p>
C206 		<p>Removal:</p> 

SIIA0315E

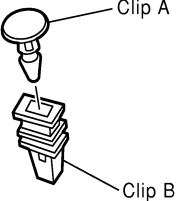
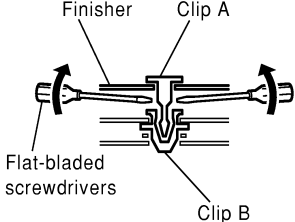
A
B
C
D
E
F
G
H
I
J
EXT
L
M
N
O
P

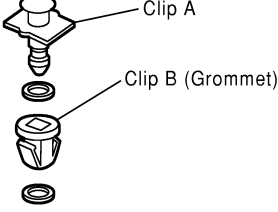
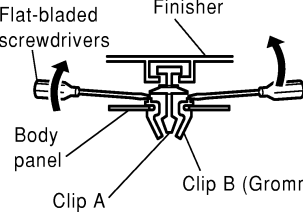
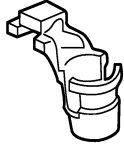
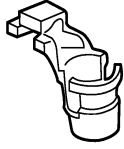
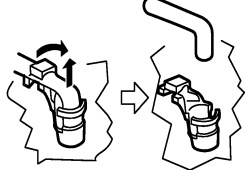
CLIP LIST

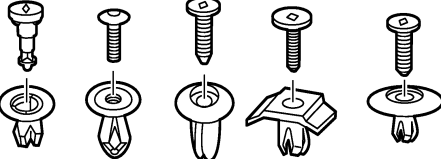







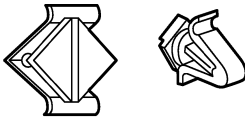

< SERVICE INFORMATION >

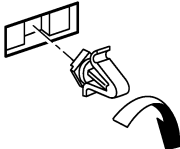
Symbol No.	Shapes	Removal & Installation
<p>CE103</p> 		<p>Removal:</p> 
<p>CF110</p> 		<p>Removal:</p> 
<p>CF118</p> 		<p>Removal:</p> 
<p>CR103</p> 		<p>Removal: Holder portion of clip must be spread out to remove rod.</p> 
<p>CS101</p> 		<p>Removal:</p> <ol style="list-style-type: none"> 1. Screw out with a Phillips screwdriver. 2. Remove female portion with flat-bladed screwdriver. 

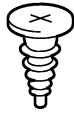
SIIA0316E

CLIP LIST

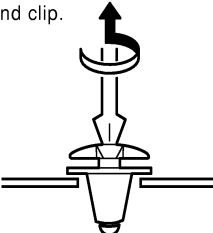
< SERVICE INFORMATION >

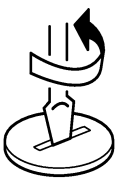



Symbol No.	Shapes	Removal & Installation	
CG101 		Removal:  Rotate 45° to remove	Installation: 
CS102 			
CS113 		Removal: Disconnect upper connection of clip with a flat-bladed screwdriver, then remove clip while inserting a flat-bladed screwdriver between body panel and clip. 	
C111 			

S1IA0317E

A
B
C
D
E
F
G
H
I
J
EXT
L
M
N
O
P

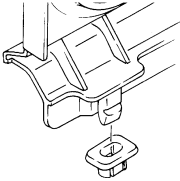
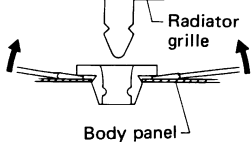
CLIP LIST

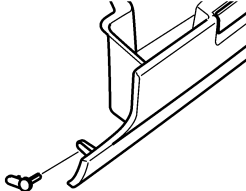
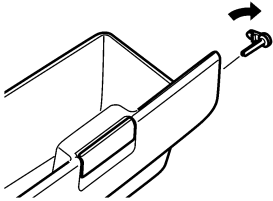
< SERVICE INFORMATION >

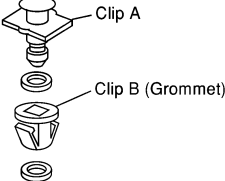
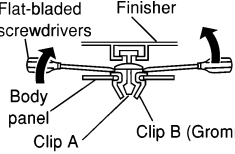
Symbol No.	Shapes	Removal & Installation
<p>CG104</p> 		<p>Removal: Remove by bending up with flat-bladed screwdrivers.</p>  <p>Radiator grille Body panel</p>
<p>CE114</p> 		
<p>CF118</p> 	 <p>Clip A Clip B (Grommet)</p>	<p>Removal: Flat-bladed screwdrivers Finisher</p>  <p>Body panel Clip A Clip B (Grommet)</p>

ALJIA0564GB

SQUEAK AND RATTLE TROUBLE DIAGNOSES

< SERVICE INFORMATION >

SQUEAK AND RATTLE TROUBLE DIAGNOSES

Work Flow

INFOID:000000011289275

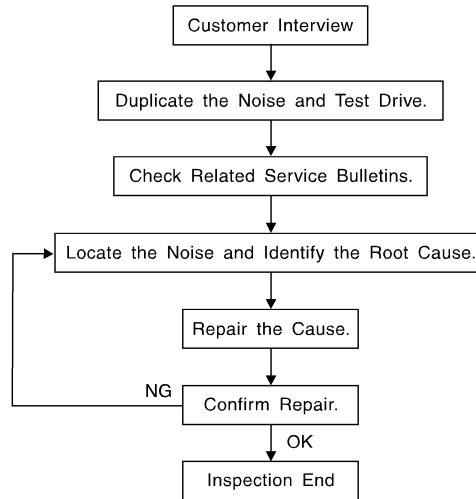

SBT842

CUSTOMER INTERVIEW

Interview the customer if possible, to determine the conditions that exist when the noise occurs. Use the Diagnostic Worksheet during the interview to document the facts and conditions when the noise occurs and any customer's comments; refer to [EXT-13, "Diagnostic Worksheet"](#). This information is necessary to duplicate the conditions that exist when the noise occurs.

- The customer may not be able to provide a detailed description or the location of the noise. Attempt to obtain all the facts and conditions that exist when the noise occurs (or does not occur).
- If there is more than one noise in the vehicle, be sure to diagnose and repair the noise that the customer is concerned about. This can be accomplished by test driving the vehicle with the customer.
- After identifying the type of noise, isolate the noise in terms of its characteristics. The noise characteristics are provided so the customer, service adviser and technician are all speaking the same language when defining the noise.

- Squeak —(Like tennis shoes on a clean floor)

Squeak characteristics include the light contact/fast movement/brought on by road conditions/hard surfaces = higher pitch noise/softer surfaces = lower pitch noises/edge to surface = chirping.

- Creak—(Like walking on an old wooden floor)
Creak characteristics include firm contact/slow movement/twisting with a rotational movement/pitch dependent on materials/often brought on by activity.

- Rattle—(Like shaking a baby rattle)

Rattle characteristics include the fast repeated contact/vibration or similar movement/loose parts/missing clip or fastener/incorrect clearance.

- Knock —(Like a knock on a door)

Knock characteristics include hollow sounding/sometimes repeating/often brought on by driver action.

- Tick—(Like a clock second hand)

Tick characteristics include gentle contacting of light materials/loose components/can be caused by driver action or road conditions.

- Thump—(Heavy, muffled knock noise)

Thump characteristics include softer knock/dead sound often brought on by activity.

- Buzz—(Like a bumble bee)

Buzz characteristics include high frequency rattle/firm contact.

- Often the degree of acceptable noise level will vary depending upon the person. A noise that you may judge as acceptable may be very irritating to the customer.

- Weather conditions, especially humidity and temperature, may have a great effect on noise level.

DUPLICATE THE NOISE AND TEST DRIVE

If possible, drive the vehicle with the customer until the noise is duplicated. Note any additional information on the Diagnostic Worksheet regarding the conditions or location of the noise. This information can be used to duplicate the same conditions when you confirm the repair.

SQUEAK AND RATTLE TROUBLE DIAGNOSES

< SERVICE INFORMATION >

If the noise can be duplicated easily during the test drive, to help identify the source of the noise, try to duplicate the noise with the vehicle stopped by doing one or all of the following:

- 1) Close a door.
 - 2) Tap or push/pull around the area where the noise appears to be coming from.
 - 3) Rev the engine.
 - 4) Use a floor jack to recreate vehicle "twist".
 - 5) At idle, apply engine load (electrical load, half-clutch on M/T model, drive position on CVT and A/T models).
 - 6) Raise the vehicle on a hoist and hit a tire with a rubber hammer.
- Drive the vehicle and attempt to duplicate the conditions the customer states exist when the noise occurs.
 - If it is difficult to duplicate the noise, drive the vehicle slowly on an undulating or rough road to stress the vehicle body.

CHECK RELATED SERVICE BULLETINS

After verifying the customer concern or symptom, check ASIST for Technical Service Bulletins (TSBs) related to that concern or symptom.

If a TSB relates to the symptom, follow the procedure to repair the noise.

LOCATE THE NOISE AND IDENTIFY THE ROOT CAUSE

1. Narrow down the noise to a general area. To help pinpoint the source of the noise, use a listening tool (Chassis Ear: J-39570, Engine Ear: J-39565 and mechanic's stethoscope).
2. Narrow down the noise to a more specific area and identify the cause of the noise by:
 - removing the components in the area that you suspect the noise is coming from.
Do not use too much force when removing clips and fasteners, otherwise clips and fasteners can be broken or lost during the repair, resulting in the creation of new noise.
 - tapping or pushing/pulling the component that you suspect is causing the noise.
Do not tap or push/pull the component with excessive force, otherwise the noise will be eliminated only temporarily.
 - feeling for a vibration with your hand by touching the component(s) that you suspect is (are) causing the noise.
 - placing a piece of paper between components that you suspect are causing the noise.
 - looking for loose components and contact marks.Refer to [EXT-10, "Generic Squeak and Rattle Troubleshooting"](#).

REPAIR THE CAUSE

- If the cause is a loose component, tighten the component securely.
- If the cause is insufficient clearance between components:
 - separate components by repositioning or loosening and retightening the component, if possible.
 - insulate components with a suitable insulator such as urethane pads, foam blocks, felt cloth tape or urethane tape. A NISSAN Squeak and Rattle Kit (J-50397) is available through your authorized NISSAN Parts Department.

CAUTION:

Do not use excessive force as many components are constructed of plastic and may be damaged.

NOTE:

- Always check with the Parts Department for the latest parts information.
- The materials contained in the NISSAN Squeak and Rattle Kit (J-50397) are listed on the inside cover of the kit; and can each be ordered separately as needed.
- The following materials not found in the kit can also be used to repair squeaks and rattles.
 - SILICONE GREASE: Use instead of UHMW tape that will be visible or does not fit. The silicone grease will only last a few months.
 - SILICONE SPRAY: Use when grease cannot be applied.
 - DUCT TAPE: Use to eliminate movement.

CONFIRM THE REPAIR

Confirm that the cause of a noise is repaired by test driving the vehicle. Operate the vehicle under the same conditions as when the noise originally occurred. Refer to the notes on the Diagnostic Worksheet.

Generic Squeak and Rattle Troubleshooting

INFOID:000000011289276

Refer to Table of Contents for specific component removal and installation information.

INSTRUMENT PANEL

Most incidents are caused by contact and movement between:

SQUEAK AND RATTLE TROUBLE DIAGNOSES

< SERVICE INFORMATION >

1. Cluster lid A and the instrument panel
2. Acrylic lens and combination meter housing
3. Instrument panel to front pillar finisher
4. Instrument panel to windshield
5. Instrument panel pins
6. Wiring harnesses behind the combination meter
7. A/C defroster duct and duct joint

These incidents can usually be located by tapping or moving the components to duplicate the noise or by pressing on the components while driving to stop the noise. Most of these incidents can be repaired by applying felt cloth tape or silicone spray (in hard to reach areas). Urethane pads can be used to insulate wiring harness.

CAUTION:

Do not use silicone spray to isolate a squeak or rattle. If you saturate the area with silicone, you will not be able to recheck the repair.

CENTER CONSOLE

Components to pay attention to include:

1. Shift selector assembly cover to finisher
2. A/C control unit and cluster lid C
3. Wiring harnesses behind audio and A/C control unit

The instrument panel repair and isolation procedures also apply to the center console.

DOORS

Pay attention to the:

1. Finisher and inner panel making a slapping noise
2. Inside handle escutcheon to door finisher
3. Wiring harnesses tapping
4. Door striker out of alignment causing a popping noise on starts and stops

Tapping or moving the components or pressing on them while driving to duplicate the conditions can isolate many of these incidents. You can usually insulate the areas with felt cloth tape or insulator foam blocks from the NISSAN Squeak and Rattle Kit (J-50397) to repair the noise.

TRUNK

Trunk noises are often caused by a loose jack or loose items put into the trunk by the owner.

In addition look for:

1. Trunk lid bumpers out of adjustment
2. Trunk lid striker out of adjustment
3. The trunk lid torsion bars knocking together
4. A loose license plate or bracket

Most of these incidents can be repaired by adjusting, securing or insulating the item(s) or component(s) causing the noise.

SUNROOF/HEADLINING

Noises in the sunroof/headlining area can often be traced to one of the following:

1. Sunroof lid, rail, linkage or seals making a rattle or light knocking noise
2. Sun visor shaft shaking in the holder
3. Front or rear windshield touching headlining and squeaking

Again, pressing on the components to stop the noise while duplicating the conditions can isolate most of these incidents. Repairs usually consist of insulating with felt cloth tape.

OVERHEAD CONSOLE (FRONT AND REAR)

Overhead console noises are often caused by the console panel clips not being engaged correctly. Most of these incidents are repaired by pushing up on the console at the clip locations until the clips engage.

In addition look for:

1. Loose harness or harness connectors.
2. Front console map/reading lamp lens loose.

SQUEAK AND RATTLE TROUBLE DIAGNOSES

< SERVICE INFORMATION >

3. Loose screws at console attachment points.

SEATS

When isolating seat noise it's important to note the position the seat is in and the load placed on the seat when the noise is present. These conditions should be duplicated when verifying and isolating the cause of the noise.

Cause of seat noise include:

1. Headrest rods and holder
2. A squeak between the seat pad cushion and frame
3. The rear seatback lock and bracket

These noises can be isolated by moving or pressing on the suspected components while duplicating the conditions under which the noise occurs. Most of these incidents can be repaired by repositioning the component or applying urethane tape to the contact area.

UNDERHOOD

Some interior noise may be caused by components under the hood or on the engine wall. The noise is then transmitted into the passenger compartment.

Causes of transmitted underhood noise include:

1. Any component installed to the engine wall
2. Components that pass through the engine wall
3. Engine wall mounts and connectors
4. Loose radiator installation pins
5. Hood bumpers out of adjustment
6. Hood striker out of adjustment

These noises can be difficult to isolate since they cannot be reached from the interior of the vehicle. The best method is to secure, move or insulate one component at a time and test drive the vehicle. Also, engine rpm or load can be changed to isolate the noise. Repairs can usually be made by moving, adjusting, securing, or insulating the component causing the noise.

SQUEAK AND RATTLE TROUBLE DIAGNOSES

< SERVICE INFORMATION >

Diagnostic Worksheet

INFOID:000000011289277

Dear Customer:

We are concerned about your satisfaction with your vehicle. Repairing a squeak or rattle sometimes can be very difficult. To help us fix your vehicle right the first time, please take a moment to note the area of the vehicle where the squeak or rattle occurs and under what conditions. You may be asked to take a test drive with a service advisor or technician to ensure we confirm the noise you are hearing.

SQUEAK & RATTLE DIAGNOSTIC WORKSHEET

I. WHERE DOES THE NOISE COME FROM? (circle the area of the vehicle)

The illustrations are for reference only, and may not reflect the actual configuration of your vehicle.

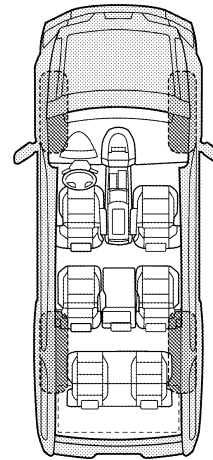
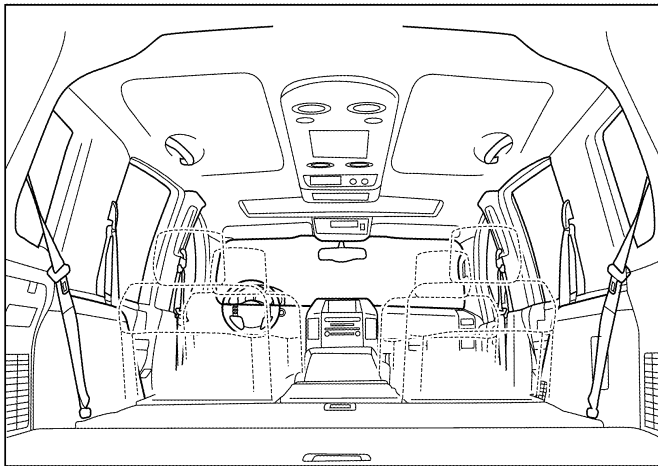
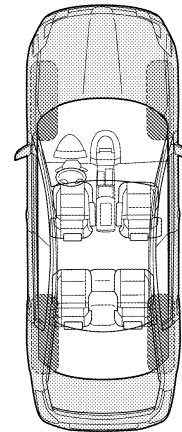
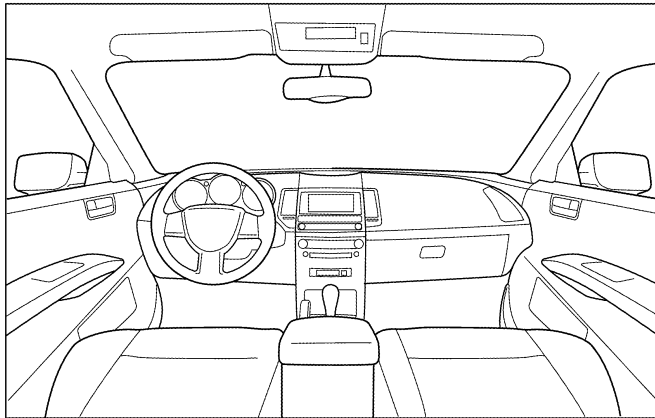

Continue to page 2 of the worksheet and briefly describe the location of the noise or rattle. In addition, please indicate the conditions which are present when the noise occurs.

A
B
C
D
E
F
G
H
I
J
EXT
L
M
N
O
P

SQUEAK AND RATTLE TROUBLE DIAGNOSES

< SERVICE INFORMATION >

SQUEAK & RATTLE DIAGNOSTIC WORKSHEET - page 2

Briefly describe the location where the noise occurs:

II. WHEN DOES IT OCCUR? (please check the boxes that apply)

- | | |
|---|--|
| <input type="checkbox"/> Anytime | <input type="checkbox"/> After sitting out in the rain |
| <input type="checkbox"/> 1st time in the morning | <input type="checkbox"/> When it is raining or wet |
| <input type="checkbox"/> Only when it is cold outside | <input type="checkbox"/> Dry or dusty conditions |
| <input type="checkbox"/> Only when it is hot outside | <input type="checkbox"/> Other: |

III. WHEN DRIVING:

- Through driveways
- Over rough roads
- Over speed bumps
- Only about ____ mph
- On acceleration
- Coming to a stop
- On turns: left, right or either (circle)
- With passengers or cargo
- Other: _____
- After driving ____ miles or ____ minutes

IV. WHAT TYPE OF NOISE

- Squeak (like tennis shoes on a clean floor)
- Creak (like walking on an old wooden floor)
- Rattle (like shaking a baby rattle)
- Knock (like a knock at the door)
- Tick (like a clock second hand)
- Thump (heavy muffled knock noise)
- Buzz (like a bumble bee)

TO BE COMPLETED BY DEALERSHIP PERSONNEL

Test Drive Notes:

	YES	NO	Initials of person performing
Vehicle test driven with customer	<input type="checkbox"/>	<input type="checkbox"/>	_____
- Noise verified on test drive	<input type="checkbox"/>	<input type="checkbox"/>	_____
- Noise source located and repaired	<input type="checkbox"/>	<input type="checkbox"/>	_____
- Follow up test drive performed to confirm repair	<input type="checkbox"/>	<input type="checkbox"/>	_____

VIN: _____ Customer Name _____
 W.O.# _____ Date: _____

This form must be attached to Work Order

LATA0071E

FRONT BUMPER

< SERVICE INFORMATION >

FRONT BUMPER

Removal and Installation

INFOID:000000011289278

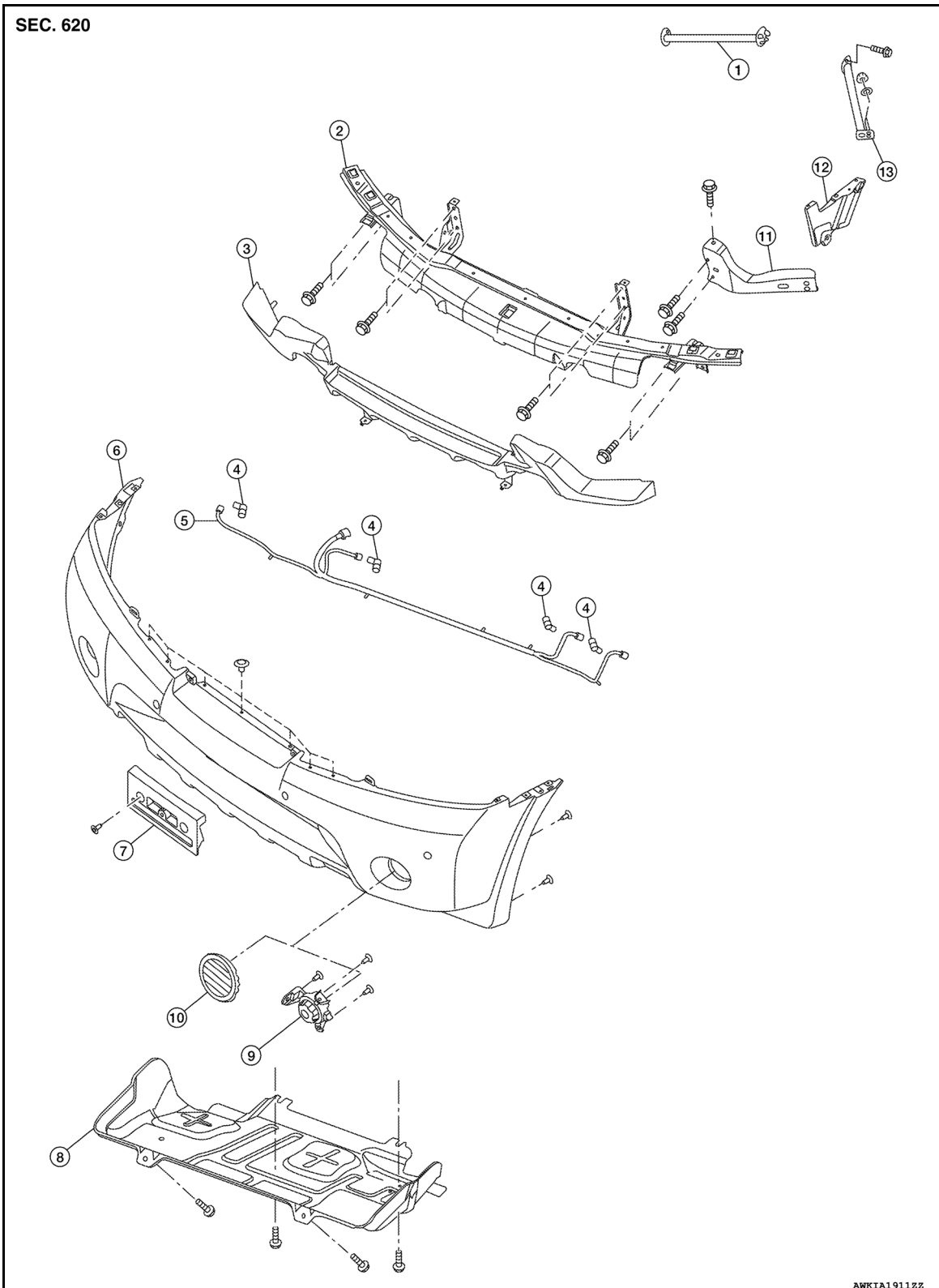

- | | | |
|--------------------------------|---------------------------------------|------------------------------------|
| 1. Strut brace | 2. Front bumper reinforcement | 3. Energy absorber |
| 4. Sonar sensors (if equipped) | 5. Sonar sensor harness (if equipped) | 6. Front bumper fascia |
| 7. License plate bracket | 8. Engine under cover | 9. Fog lamp assembly (if equipped) |

A
B
C
D
E
F
G
H
I
J
EXT
L
M
N
O
P

FRONT BUMPER

< SERVICE INFORMATION >

- | | | |
|---|------------------------|-------------|
| 10. Fog lamp opening finisher (if equipped) | 11. Side reinforcement | 12. Bracket |
| 13. Strut brace | | |

REMOVAL

1. Remove the front grille. Refer to [EXT-23, "Removal and Installation"](#).
2. Partially remove the front fender protectors (LH/RH). Refer to [EXT-27, "Removal and Installation"](#).
3. Disconnect the harness connectors from the fog lamps (LH/RH) (if equipped).
4. Disconnect the harness connectors from the front sonar sensors (LH/RH) (if equipped).
5. Remove the front bumper fascia screws, then remove the front bumper fascia.
6. Remove the front sonar sensor harness, then remove the front sonar sensors (if equipped).
7. Disconnect the front sonar sensor retainers (if equipped).
8. Remove the front fog lamp screws, then remove the front fog lamps (if equipped).
9. Remove the side reinforcement (LH/RH) bolts.
10. Remove the strut brace (LH/RH) nuts and the side reinforcements (LH/RH).
11. Remove the strut brace (LH/RH) bolts and the strut braces (LH/RH).
12. Remove the front bumper energy absorber.
13. Remove the front bumper reinforcement bolts and the front bumper reinforcement.

INSTALLATION

Installation is in the reverse order of removal.

- Adjust fog lamp aiming (if equipped). Refer to [EXL-133, "FRONT FOG LAMP : Aiming Adjustment"](#).

FRONT BUMPER

< SERVICE INFORMATION >

SEC. 620

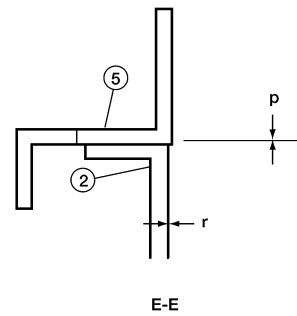
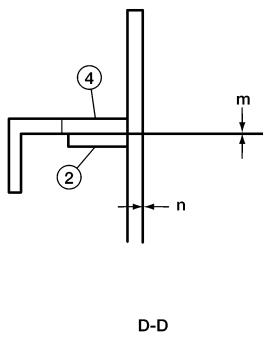
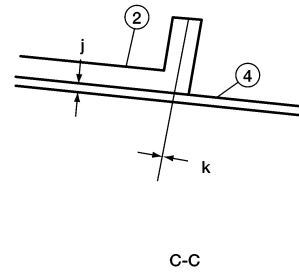
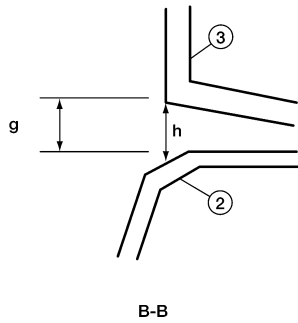
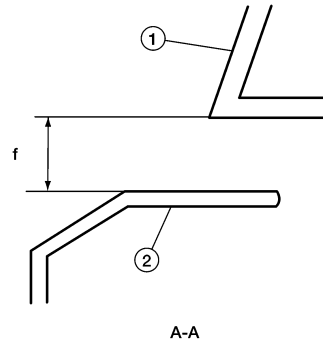
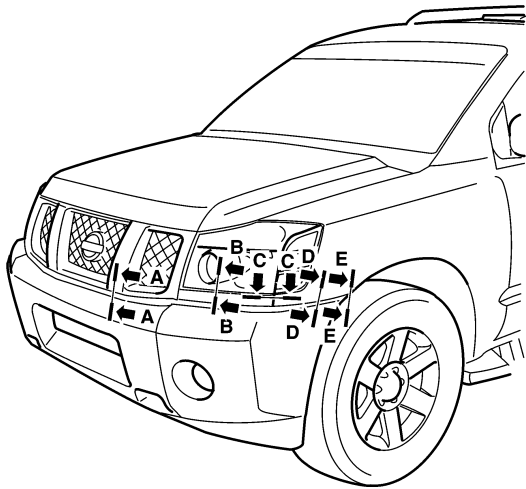

- 1. Front grille
- 2. Front bumper fascia
- 3. Front combination lamp
- 4. Front fender
- 5. Front fender wheel opening finisher

AWKIA2079ZZ

Units: mm (in)

Portion	Measurement	Standard	Difference (MAX)
A-A	f Clearance	3.0 (0.2)	±1.0 (0.04)

A
B
C
D
E
F
G
H
I
J
EXT
L
M
N
O
P

FRONT BUMPER

< SERVICE INFORMATION >

B-B	g	Clearance	3.0 (0.2)	±1.5 (0.06)
	h	Surface height	1.5 (0.06)	±1.5 (0.06)
C-C	j	Surface height	0.75 (0.030)	±1.0 (0.04)
	k	Clearance	0.0	+1.0 (0.04)
D-D	m	Clearance	0.0	+1.0 (0.04)
	n	Surface height	0.75 (0.030)	±1.0 (0.04)
E-E	p	Surface height	0.0	±1.0 (0.04)
	r	Clearance	0.0	+1.0 (0.04)

REAR BUMPER

< SERVICE INFORMATION >

REAR BUMPER

Removal and Installation

INFOID:000000011289279

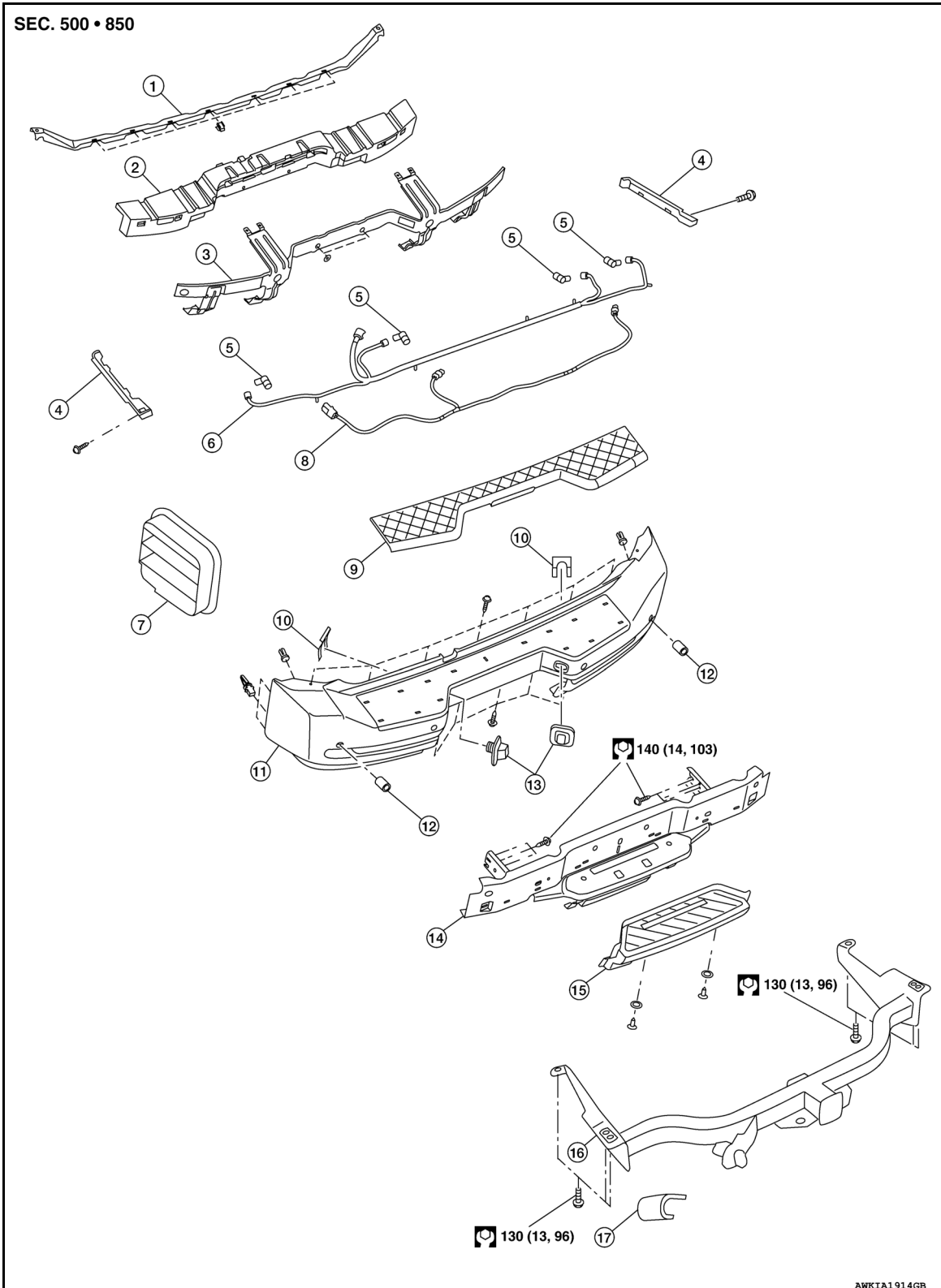

A
B
C
D
E
F
G
H
I
J
EXT
L
M
N
O
P

REAR BUMPER

< SERVICE INFORMATION >

- | | | |
|---|---|--|
| 1. Rear bumper fascia reinforcement | 2. Rear bumper energy absorber | 3. Rear bumper energy absorber reinforcement |
| 4. Lower rear bumper fascia reinforcement finishers LH and RH | 5. Rear sonar sensors | 6. Rear sonar sensor harness |
| 7. Drafter duct | 8. License lamp harness | 9. Upper step pad |
| 10. License lamp clips | 11. Rear bumper fascia | 12. Rear sonar sensor retainers |
| 13. License lamps | 14. Lower step pad reinforcement | 15. Lower step pad |
| 16. Tow hitch (if equipped) | 17. Tow hitch harness cover (if equipped) | |

REMOVAL

1. Remove the rear combination lamps. Refer to [EXL-145. "Removal and Installation"](#).
2. Remove the LH and RH lower rear bumper fascia reinforcement finisher screws, then remove the lower rear bumper fascia reinforcements finishers.
3. Disconnect the rear sonar sensor harness connector (if equipped).
4. Disconnect the license lamp harness connector.
5. Remove the rear bumper fascia screws, then remove the rear bumper fascia.
6. Remove the license lamp clips from the license lamps and remove the license lamps.
7. Remove the rear sonar sensor harness, then remove the rear sonar sensors.
8. Disconnect the rear sonar sensor retainers.
9. Release the clips and remove the upper step pad.
10. Remove the rear bumper energy absorber.
11. Remove the lower step pad screws, then release the clips and remove the lower step pad.
12. Remove the reflector screws, then remove the reflectors.
13. Disconnect the harness on left side of lower step pad reinforcement.
14. Remove the lower step pad reinforcement bolts, then remove the lower step pad reinforcement.
15. Remove the rear bumper fascia reinforcement nuts, then remove the rear bumper fascia reinforcement.
16. Remove the drafter duct from under the LH quarter panel, if necessary.

INSTALLATION

Installation is in the reverse order of removal.

- Apply sealant to clips securing upper step pad during installation.

REAR BUMPER

< SERVICE INFORMATION >

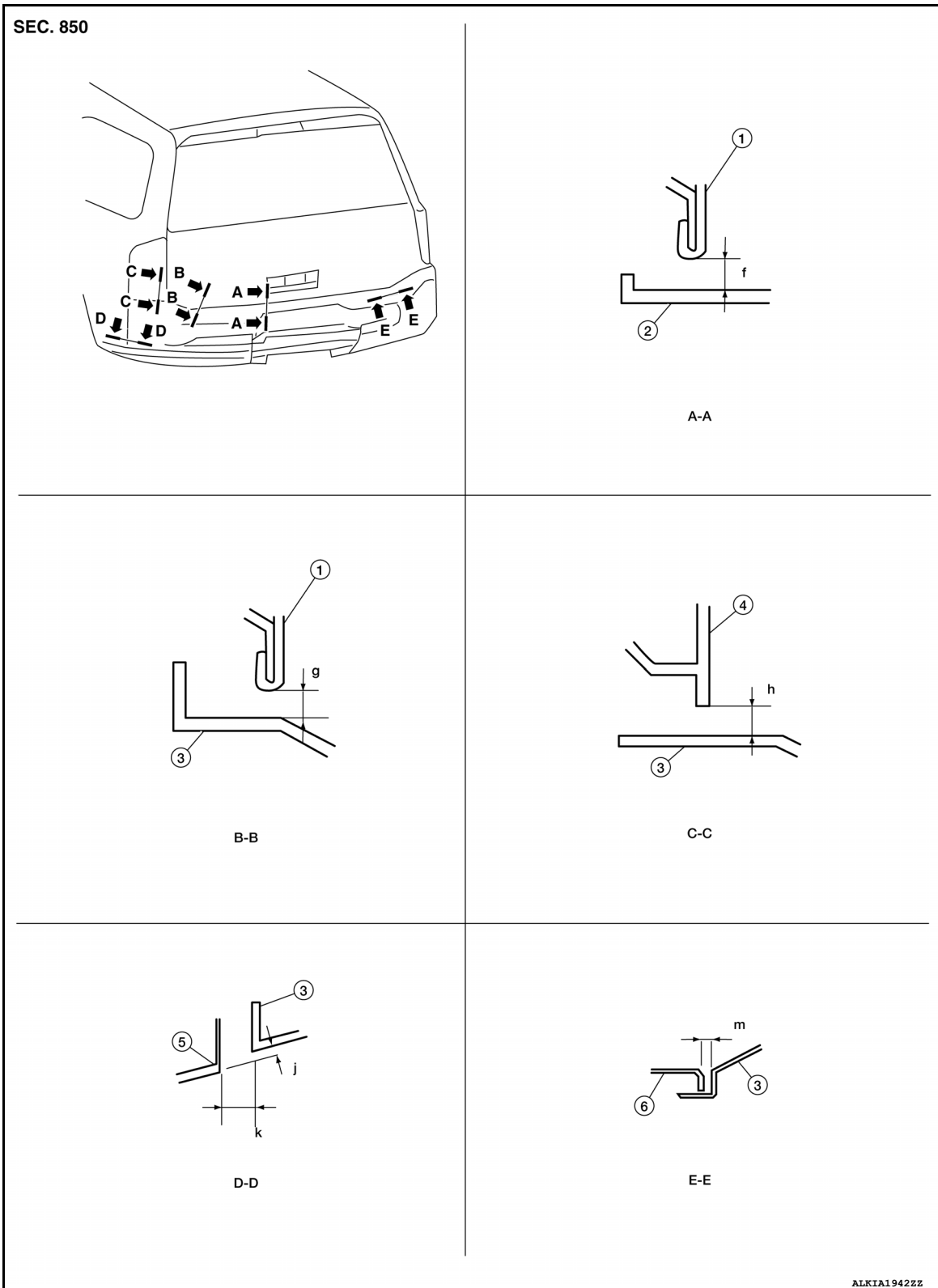

- | | | |
|--------------------------|-------------------------|-----------------------|
| 1. Back door | 2. Rear bumper | 3. Rear bumper fascia |
| 4. Rear combination lamp | 5. Rear body side outer | 6. Upper step pad |

Units: mm (in)

Portion	Measurement	Standard	Difference (MAX)
A-A	f Clearance	12.0 (0.47)	±2.5 (0.10)

A
B
C
D
E
F
G
H
I
J
EXT
L
M
N
O
P

REAR BUMPER

< SERVICE INFORMATION >

B-B	g	Clearance	12.0 (0.47)	±2.5 (0.10)
C-C	h	Clearance	3.0 (0.12)	±1.5 (0.06)
D-D	j	Surface height	2.0 (0.08)	±1.0 (0.04)
	k	Clearance	0.0	+1.0 (0.04)
E-E	m	Clearance	4.0 (0.16)	±2.0 (0.08)

FRONT GRILLE

< SERVICE INFORMATION >

FRONT GRILLE

Removal and Installation

INFOID:000000011289280

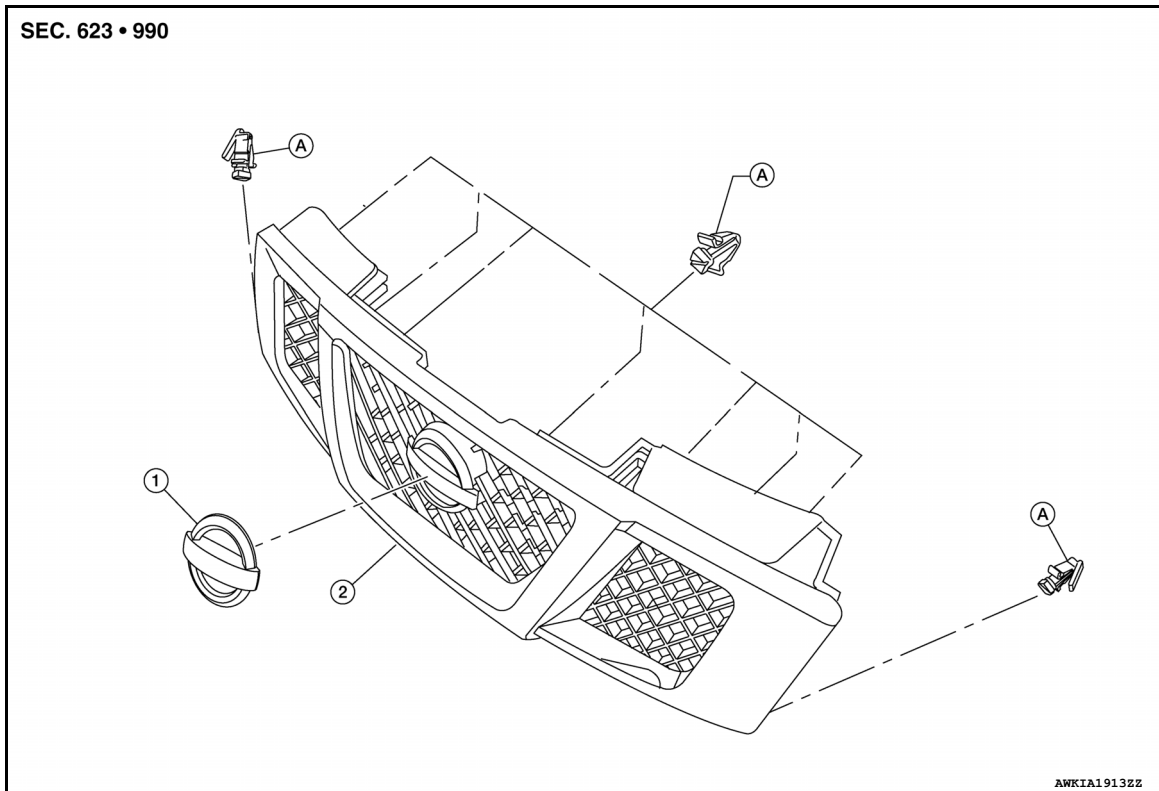

1. Front emblem

2. Front grille

A. Clip

REMOVAL

1. Release the front grille clips at the top of the front grille.
2. Release the front grille clips at the LH side, RH side and the lower part of the front grille.
3. Remove the front grille.
4. Remove the front emblem (if necessary).

INSTALLATION

Installation is in the reverse order of removal.

A
B
C
D
E
F
G
H
I
J
L
M
N
O
P

EXT

COWL TOP

< SERVICE INFORMATION >

COWL TOP

Removal and Installation

INFOID:000000011289281

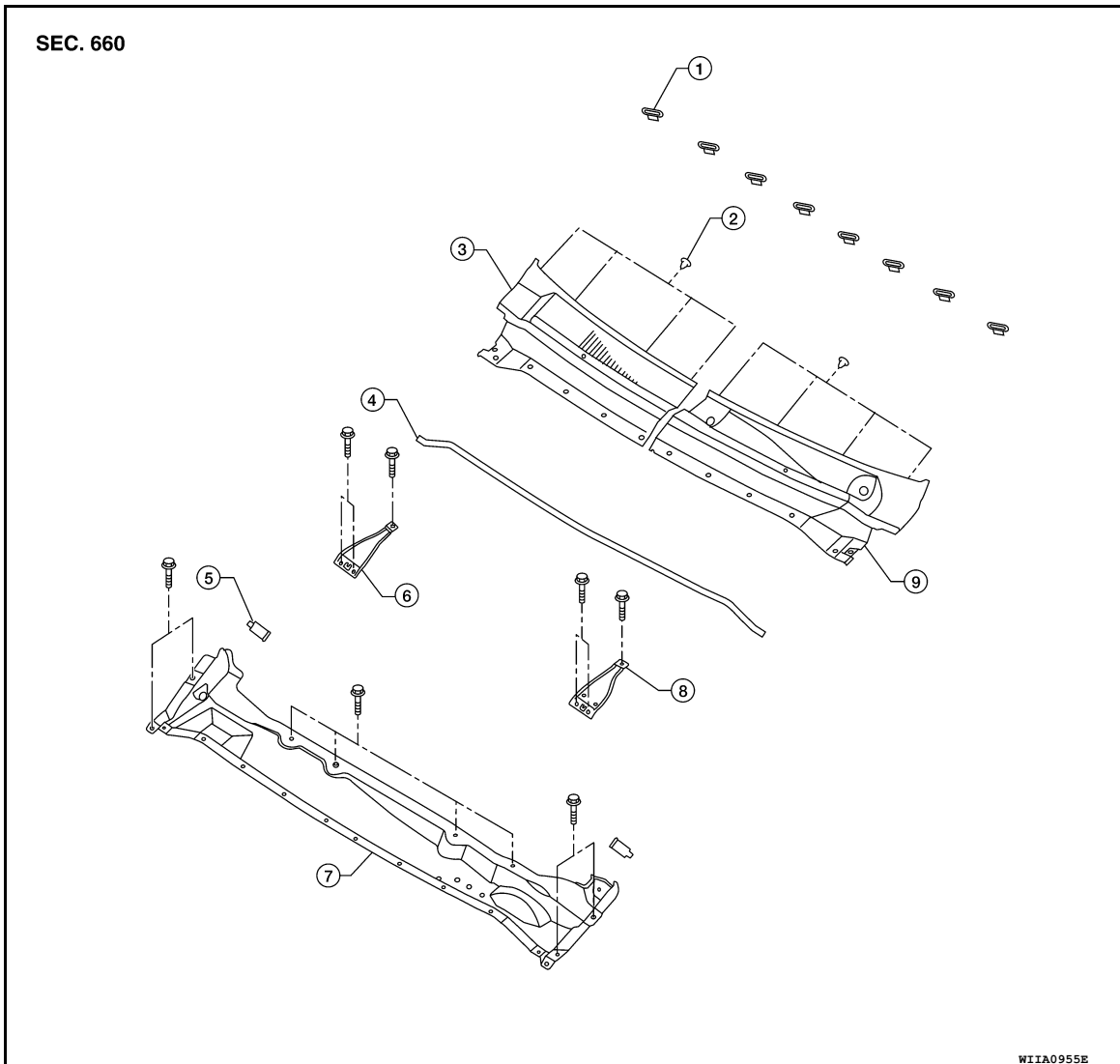

- | | | |
|-----------------------|------------------------------------|------------------------------------|
| 1. Clip | 2. Clip | 3. Cowl top cover (RH) |
| 4. Cowl top seal | 5. Drain tube | 6. Cowl top extension bracket (RH) |
| 7. Cowl top extension | 8. Cowl top extension bracket (LH) | 9. Cowl top cover (LH) |

REMOVAL

1. Remove the front wiper arms. Refer to [WW-69, "Front Wiper Arms"](#).
2. Remove cowl top seal.
 - Release plastics clips on cowl top seal which go through cowl tops (LH/RH) and cowl top extension.
3. Remove cowl top covers (LH/RH).
 - Release plastic clips under cowl top covers attaching to grommets on hoodledge.
 - Disconnect washer tubes from washer nozzles under cowl top covers.
4. Remove cowl top extension brackets (LH/RH).
 - Disconnect wiper motor harness from cowl top extension bracket (LH).
 - Cowl top extension bracket (LH) must be removed prior to removal of wiper motor and connecting rod assembly.
5. Remove wiper motor and connecting rod linkage. Refer to [WW-70, "Wiper Motor and Linkage"](#).
6. Disconnect windshield washer tube. Refer to [WW-71, "Washer Tube Layout"](#).

COWL TOP

< SERVICE INFORMATION >

7. Disconnect the water cut valve bracket from cowl top extension.
8. Remove drain tube from each side of cowl top extension.
9. Remove cowl top extension.

INSTALLATION

Installation is in the reverse order of removal.

A

B

C

D

E

F

G

H

I

J

EXT

L

M

N

O

P

FRONT FENDER

< SERVICE INFORMATION >

FRONT FENDER

Removal and Installation

INFOID:000000011289282

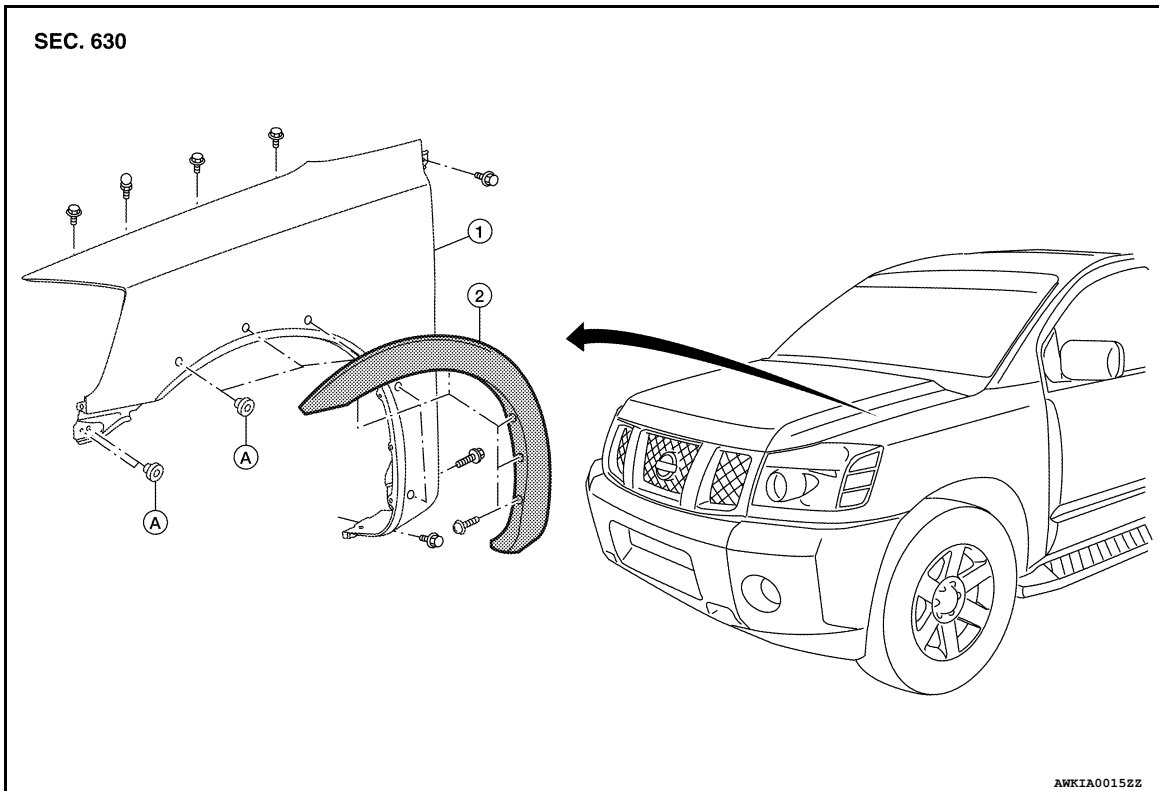

1. Front fender

2. Front fender wheel opening finisher A. Clips

REMOVAL

1. Remove the front combination lamp. Refer to [EXL-135, "Removal and Installation"](#).
2. Remove the fender protector. Refer to [EXT-27](#).
3. Remove the hood stay. Refer to [DLK-229, "Removal and Installation of Hood Assembly"](#).
4. Remove the front fender.

INSTALLATION

Installation is in the reverse order of removal.

FENDER PROTECTOR

< SERVICE INFORMATION >

FENDER PROTECTOR

Removal and Installation

INFOID:000000011289283

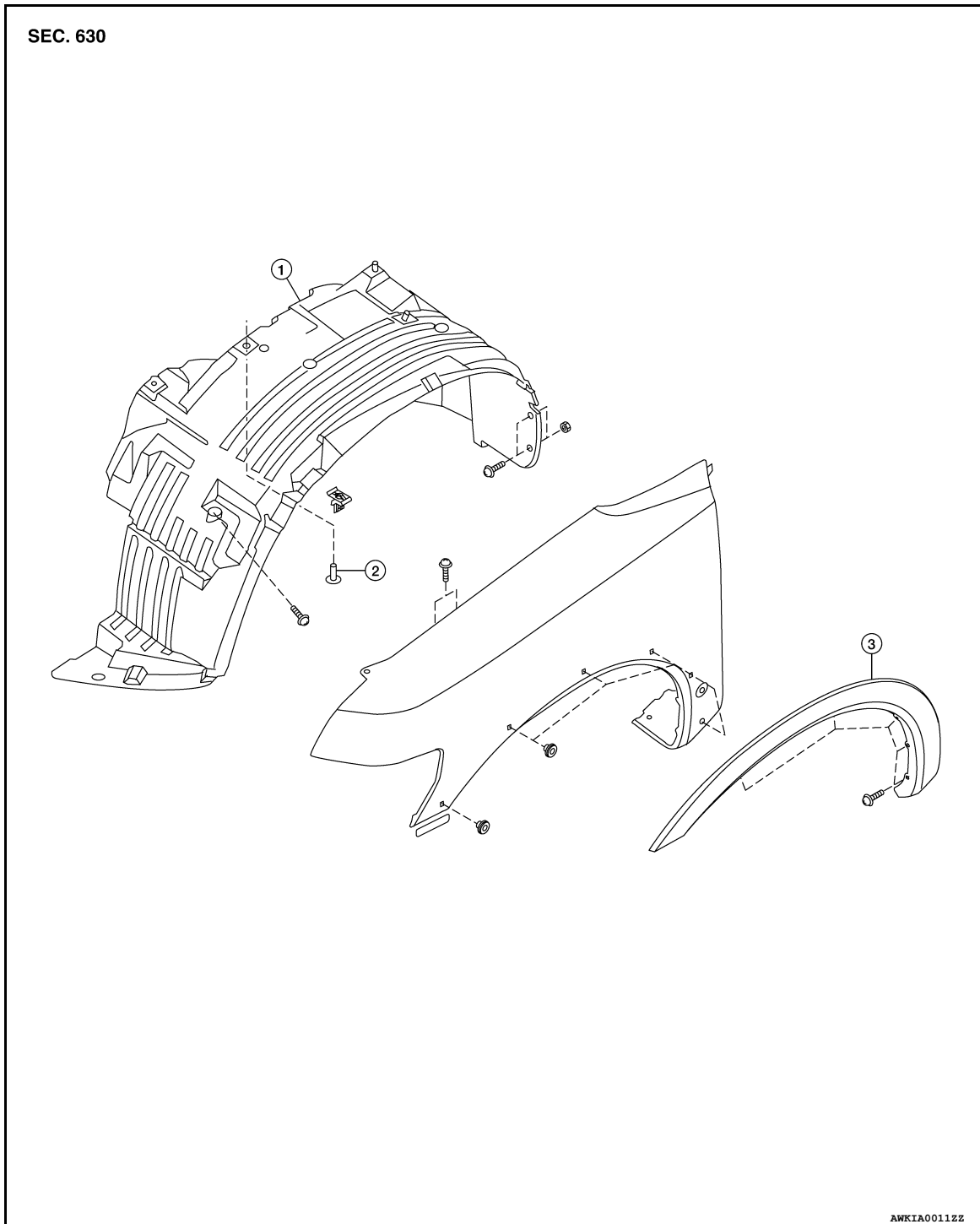

1. Front fender protector

2. Clip

3. Front fender wheel opening finisher

REMOVAL

1. Remove the front fender protector screws.
2. Remove the front fender protector clip.
3. Remove the front fender protector.

A
B
C
D
E
F
G
H
I
J
EXT
L
M
N
O
P

FENDER PROTECTOR

< SERVICE INFORMATION >

INSTALLATION

Installation is in the reverse order of removal.

RUNNING BOARDS

< SERVICE INFORMATION >

RUNNING BOARDS

Removal and Installation

INFOID:000000011289284

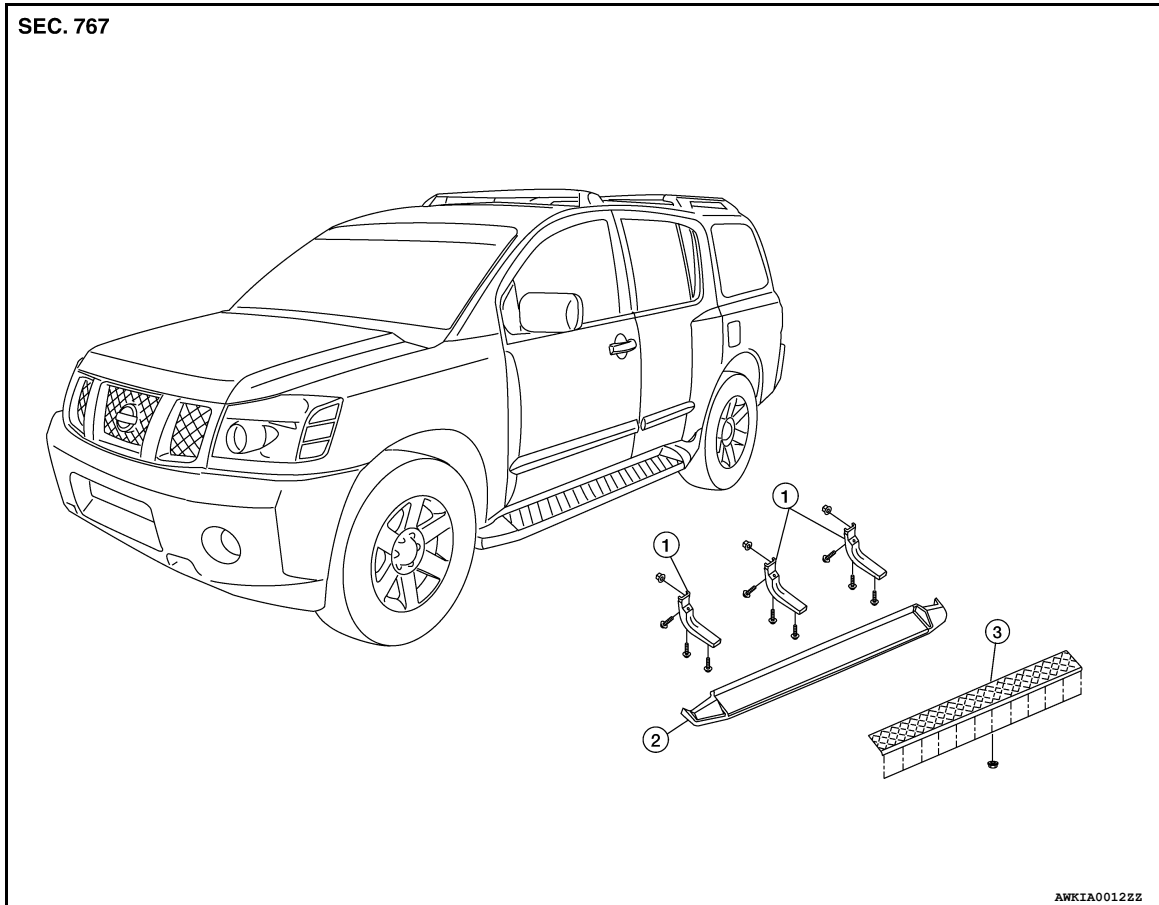

1. Running board brackets

2. Running board

3. Step pad

REMOVAL

1. Remove the running board bolts and the running board from running board brackets.
2. Remove the step pad nuts and the step pad from running board.
3. Remove the running board bracket nuts and bolts and the running board brackets.

INSTALLATION

Installation is in the reverse order of removal.

A
B
C
D
E
F
G
H
I
J

EXT

L
M
N
O
P

REAR SPOILER

< SERVICE INFORMATION >

REAR SPOILER

Removal and Installation

INFOID:000000011289285

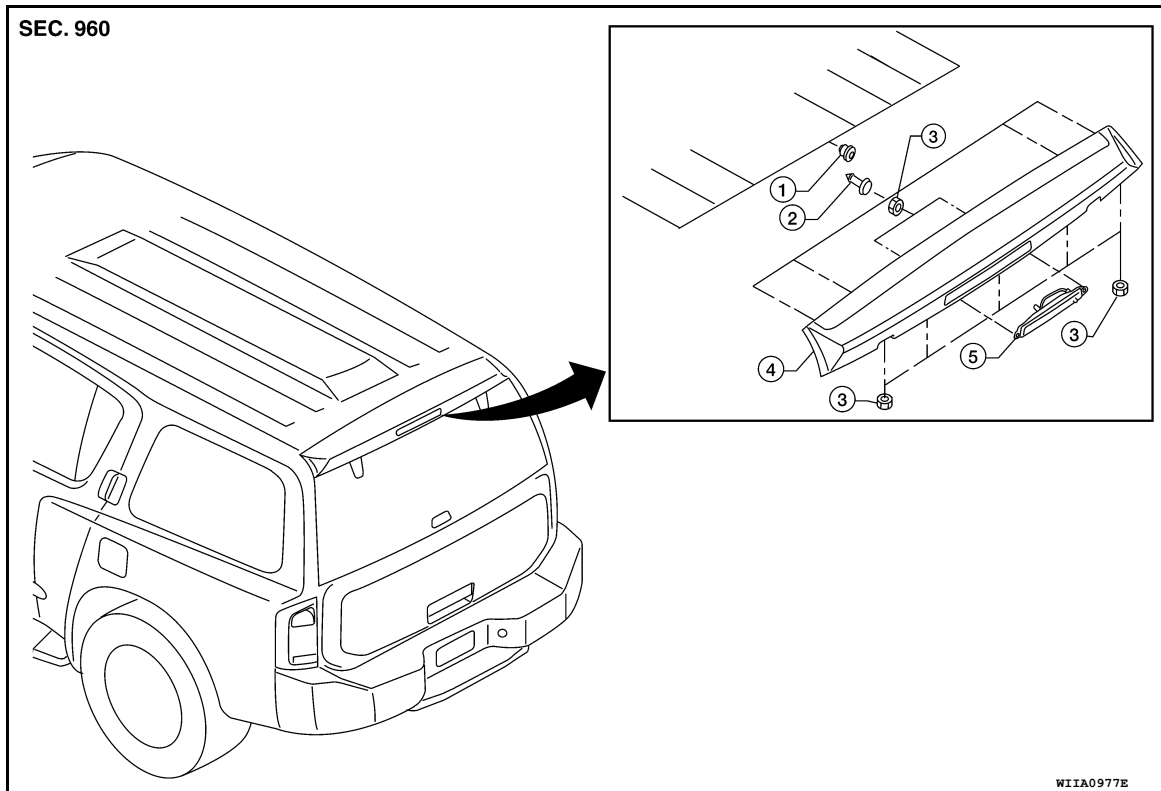

- | | | |
|---------------------|-------------------------|--------|
| 1. Grommet | 2. Clip | 3. Nut |
| 4. Rear air spoiler | 5. High mount stop lamp | |

REMOVAL

1. Remove the back door trim. Refer to [INT-27, "Removal and Installation"](#).
2. Disconnect the harness from the high mount stop lamp.
3. Disconnect the washer tube.
4. Remove the rear air spoiler nuts, release rear air spoiler clips and remove the rear air spoiler.
 - Release adhesive tape with sawing motion from monofilament line that has knots in it.
 - Remove residue of adhesive tape completely from vehicle surface with strip-off wheel or equivalent.

CAUTION:

- **Do not apply tack-paper adhesive remover to body panel surfaces finished with lacquer-based paints.**
- **Use care not to damage the vehicle surface during adhesive tape residue removal.**

5. Remove the high mount lamp nuts and the high mount stop lamp.

INSTALLATION

Installation is in the reverse order of removal.

NOTE:

Apply adhesion promoter only to areas of rear air spoiler that tape will be applied, as required.

ROOF RACK

< SERVICE INFORMATION >

ROOF RACK

Removal and Installation

INFOID:000000011289286

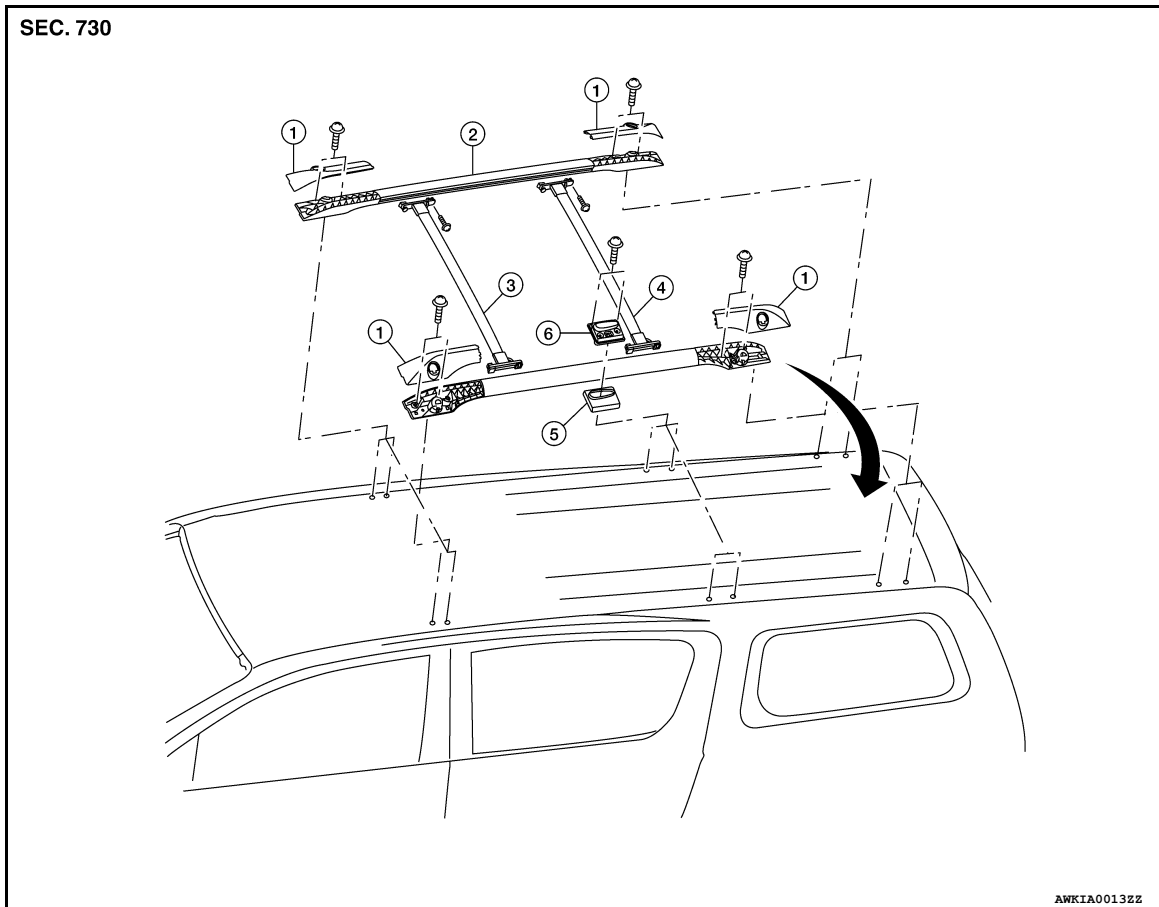

- | | | |
|--|---|---|
| 1. Finisher covers | 2. Roof rack side rails | 3. Front sliding crossbar (if equipped) |
| 4. Rear sliding crossbar (if equipped) | 5. Center support finisher covers (LH/RH) | 6. Center support mount plates (LH/RH) |

REMOVAL

1. Using a suitable tool remove the finisher covers, then remove the roof rack bolts at the four corners and slide the roof rack back enough to release the center supports.
2. Remove the complete roof rack off the vehicle.
3. Remove the center support finisher covers, the center support mount plate bolts and the center support mount plates (LH/RH).
4. Remove the front and rear sliding crossbar bolts, loosen the front and rear sliding crossbar star lock down bolts and remove the front and rear sliding crossbars.

INSTALLATION

Installation is in the reverse order of removal.

A
B
C
D
E
F
G
H
I
J

EXT

L
M
N
O
P

DOOR OUTSIDE MOLDING

< SERVICE INFORMATION >

DOOR OUTSIDE MOLDING

Removal and Installation

INFOID:000000011289287

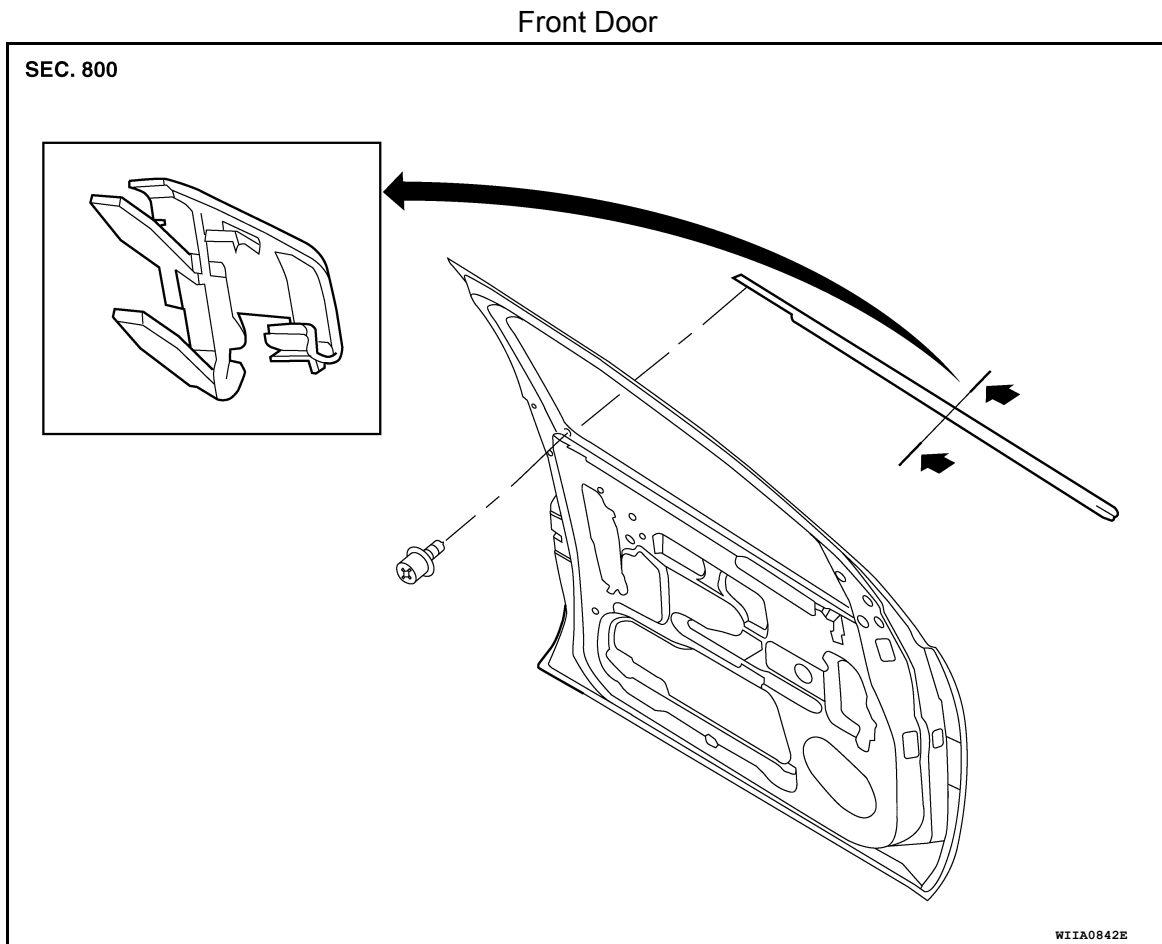

REMOVAL

1. Remove the door mirror. Refer to [MIR-21, "Door Mirror Assembly"](#).
2. Remove the front door outside molding.
 - Remove the hole cover and remove screw.
 - Lift the molding from rear edge first.
 - Disconnect the clips from the flange working forward.

INSTALLATION

Installation is in the reverse order of removal.

DOOR OUTSIDE MOLDING

< SERVICE INFORMATION >

Rear Door

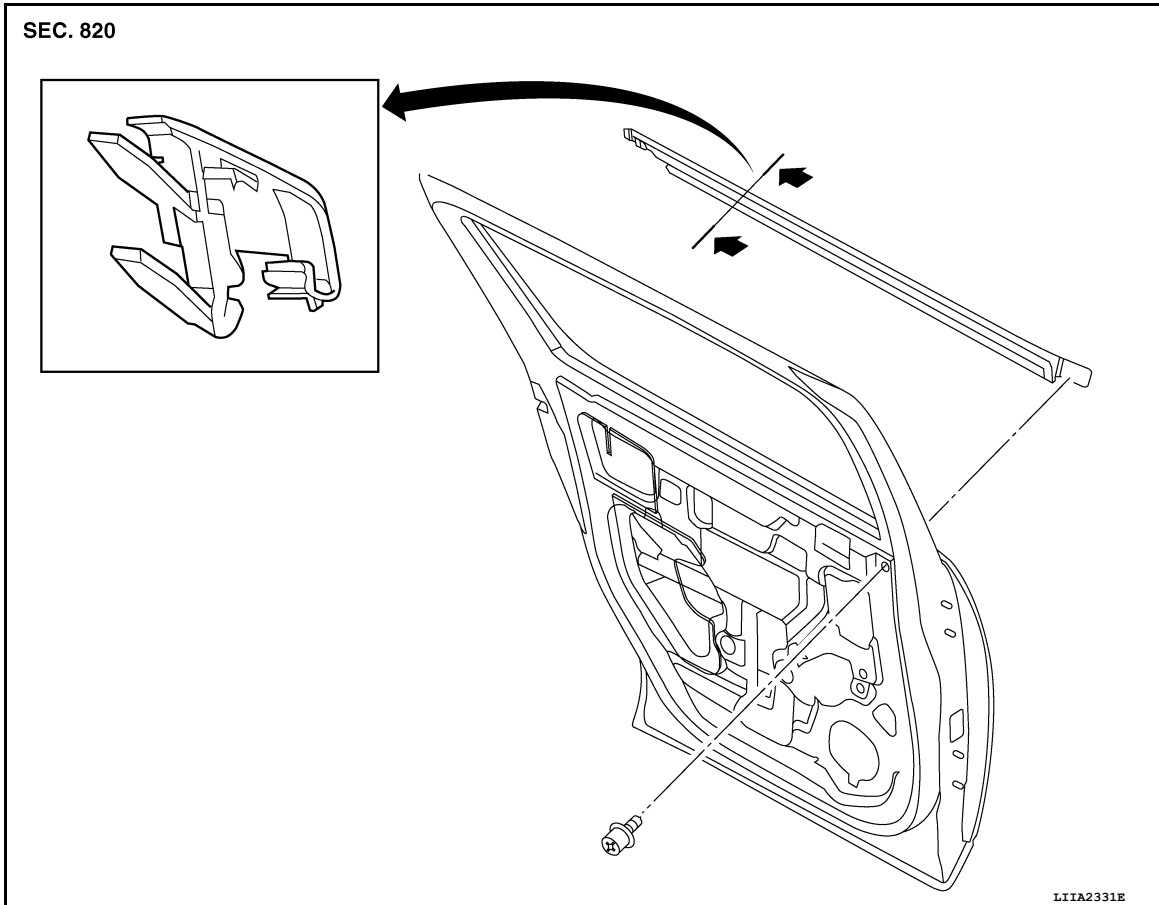

REMOVAL

1. Remove the door outside molding.
 - Remove the hole cover and remove screw.
 - Lift the molding from front edge first.
 - Disconnect the clips from the flange working rearward.

INSTALLATION

Installation is in the reverse order of removal.

A
B
C
D
E
F
G
H
I
J
EXT
L
M
N
O
P

SIDE GUARD MOLDING

< SERVICE INFORMATION >

SIDE GUARD MOLDING

Removal and Installation

INFOID:000000011289288

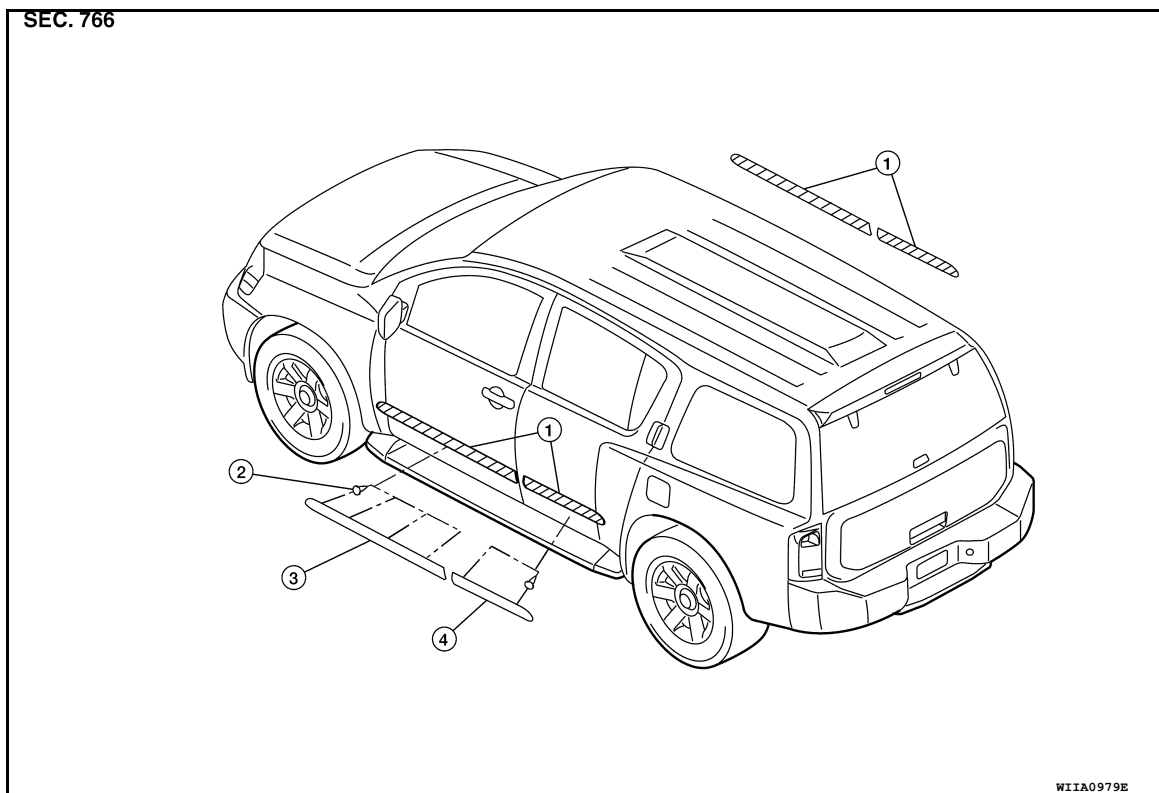

1. Double-faced adhesive tape
2. Clip
3. Front door side guard molding
4. Rear door side guard molding

REMOVAL

CAUTION:

Do not apply tack-paper adhesive remover to body panel surfaces finished with lacquer-based paints.

- Original side guard molding is affixed to body panel with double-faced adhesive tape.

1. Heat molding to between 30° and 40°C (86° to 104°F) with a heat gun.
2. Raise end of molding to release clips, then cut away tape to remove molding. Remove all traces of tape.

INSTALLATION

- On vehicles coated with Hard Clear Coat, use double-faced 3M adhesive tape Product No. 4210 or equivalent, after priming with 3M primer Product No. N200 or C-100 or equivalent.
- The repair parts are also affixed with double-faced adhesive tape.
- To re-use existing molding, clean all traces of double sided tape from the molding and apply new double-faced tape to the molding.

CAUTION:

For a secure contact, do not wash vehicle for 24 hours after installation.

1. Clean the panel surface with isopropyl alcohol or equivalent to degrease the surface.
2. Heat the panel and molding tape surface to 30° to 40°C (86° to 104°F).
3. Remove the backing sheet from the tape surface.
 - Align the locating pin into the hole in the outer door.
 - Continue aligning the pins into their corresponding holes in the outer door during installation.
4. Press ends by hand and use a roller to apply 5 kg-f (11 lbs-f) to press molding to door surface.
 - Apply even pressure along molding to insure proper wet out.