

SECTION **EX**
EXHAUST SYSTEM

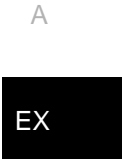

CONTENTS

PRECAUTION	2	PERIODIC MAINTENANCE	4	F
PRECAUTIONS	2	EXHAUST SYSTEM	4	
Removal and Installation	2	Inspection	4	G
PREPARATION	3	REMOVAL AND INSTALLATION	5	
PREPARATION	3	EXHAUST SYSTEM	5	H
Special Service Tools	3	Exploded View	5	
Commercial Service Tools	3	Removal and Installation	5	
		Inspection	6	I
				J
				K
				L
				M
				N
				O
				P

PRECAUTIONS

< PRECAUTION >

PRECAUTION

PRECAUTIONS

Removal and Installation

INFOID:000000005491416

CAUTION:

- Be sure to use genuine exhaust system parts or equivalents which are specially designed for heat resistance, corrosion resistance, and shape.
- Perform the operation with the exhaust system fully cooled down because the system will be hot just after engine stops.
- Be careful not to cut your hand on the heat insulator edge.

PREPARATION

< PREPARATION >

PREPARATION

PREPARATION

Special Service Tools

INFOID:000000005491417

A

EX

The actual shapes of Kent-Moore tools may differ from those of special service tools illustrated here.

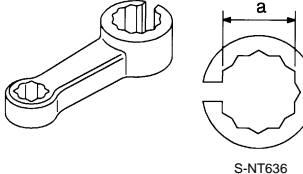
Tool number (Kent-Moore No.) Tool name	Description
KV10114400 (J-38365) Heated oxygen sensor wrench 	Loosening or tightening heated oxygen sensor 2 a: For 22 mm (0.87 in) width hexagon nut



C

D

E

Commercial Service Tools

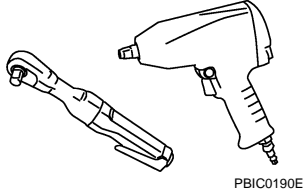
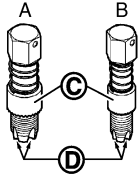
INFOID:000000005491418

(Kent-Moore No.) Tool name	Description
(—) Power tool 	Loosening nuts and bolts
A: (J-43897-18) B: (J-43897-12) Heated oxygen sensor thread cleaner 	Reconditioning the exhaust system threads before installing a new heated oxygen sensor (Use with anti-seize lubricant shown below.) A: J-43897-18 [18 mm (0.71 in) dia.] for zirconia heated oxygen sensor B: J-43897-12 [12 mm (0.47 in) dia.] for titania heated oxygen sensor C: Mating surface shave cylinder D: Flutes
(—) Anti-seize lubricant (Permatex 133AR or equivalent meeting MIL specification MIL-A-907) 	Lubricating heated oxygen sensor thread cleaner when reconditioning exhaust system threads

F

G

H

I

J

K

L

M

N

O

P

EXHAUST SYSTEM

< PERIODIC MAINTENANCE >

PERIODIC MAINTENANCE

EXHAUST SYSTEM

Inspection

INFOID:000000005491419

Check exhaust pipes, muffler, and mounting for improper attachment, leakage, cracks, damage or deterioration.

- If anything is found, repair or replace damaged parts.

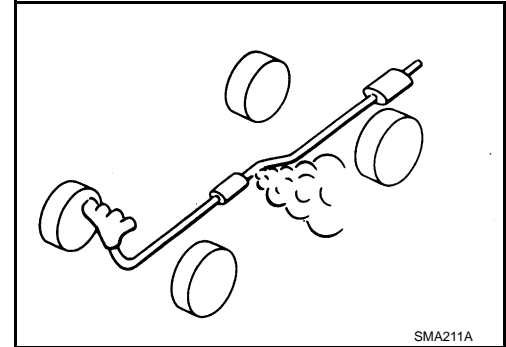

SMA211A

EXHAUST SYSTEM

< REMOVAL AND INSTALLATION >

REMOVAL AND INSTALLATION

EXHAUST SYSTEM

Exploded View

INFOID:000000005491420

A
EX

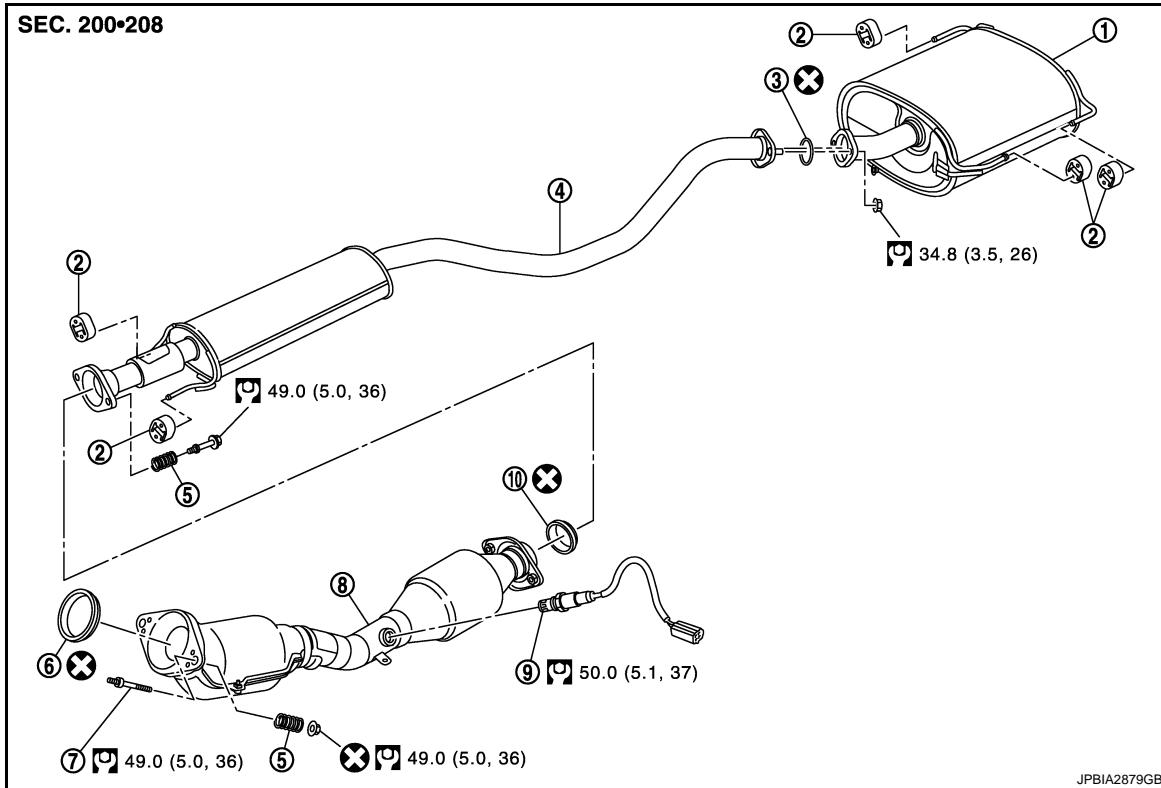

- | | | |
|-------------------|-----------------------|---------------------------|
| 1. Main muffler | 2. Mounting rubber | 3. Ring gasket |
| 4. Center muffler | 5. Spring | 6. Seal bearing |
| 7. Stud bolt | 8. Exhaust front tube | 9. Heated oxygen sensor 2 |
| 10. Seal bearing | | |

Refer to [GI-4. "Components"](#) for symbols in the figure.

Removal and Installation

INFOID:000000005491421

REMOVAL

- Disconnect each joint and mounting.
- Remove heated oxygen sensor 2 with following procedure:
- Using heated oxygen sensor wrench [SST: KV10114400 (J-38365)] (A), removal heated oxygen sensor 2 (1).

2 : Exhaust front tube

⇐ : Vehicle front

CAUTION:

Be careful not to damage heated oxygen sensor 2.

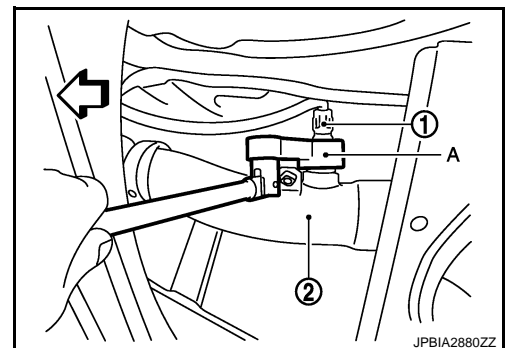

INSTALLATION

Note the following, and install in the reverse order of removal.

CAUTION:

EXHAUST SYSTEM

< REMOVAL AND INSTALLATION >

- Always replace seal bearings with new ones when reassembling.
- Discard any heated oxygen sensor 2 which has been dropped onto a hard surface such as a concrete floor. Use a new one.
- Before installing a new heated oxygen sensor 2, clean exhaust system threads using the heated oxygen sensor thread cleaner [commercial service tool: J-43897-18 or J-43897-12] and apply anti-seize lubricant (commercial service tool).
- Never over torque heated oxygen sensor 2. Doing so may cause damage to the heated oxygen sensor 2, resulting in the "MIL" coming on.
- If heat insulator is badly deformed, repair or replace it. If deposits such as mud pile up on the heat insulator, remove them.
- When installing heat insulator avoid large gaps or interference between heat insulator and each exhaust pipe.
- Remove deposits from the sealing surface of each connection. Connect them securely to avoid gas leakage.
- When installing each mounting rubber, use silicon oil to avoid twisting.
- Temporarily tighten mounting nuts and bolts. Check each part for unusual interference and mounting rubber interference, and then tighten them to the specified torque.
- When installing each mounting rubber, avoid twisting or unusual extension in up/down, front/rear and right/left directions.

Exhaust Manifold to Exhaust Front Tube

1. Securely insert seal bearing (2) into exhaust manifold (1) side in the direction shown in the figure.

- 3 : Spring
- 4 : Nut
- 5 : Stud bolt
- 6 : Exhaust front tube

CAUTION:

Be careful not to damage seal bearing surface when installing.

2. With spring, tighten nut.

CAUTION:

- Fasten stud bolts to the flange of exhaust manifold side to the specified torque before fastening mounting nuts.
- Ensure springs are seated correctly on the flange and not sitting on (A).
- Be careful that stud bolt does not interfere with mounting hole of exhaust front tube (←).

3. After installing, check that stud bolt does not interfere with mounting hole of exhaust front tube.

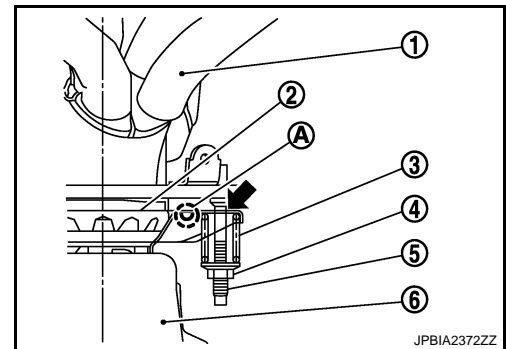

Exhaust Front Tube to Center Muffler

1. Securely insert seal bearing (2) into exhaust front tube (1) side in the direction shown in the figure.

- 3 : Spring
- 4 : Bolt
- 5 : Center muffler

CAUTION:

Be careful not to damage seal bearing surface when installing.

2. With spring, tighten bolt.

CAUTION:

- Ensure springs are seated correctly on the flange and not sitting on (A).
- Be careful that bolt does not interfere with mounting hole of center muffler (←).

3. After installing, check that bolt does not interfere with mounting hole of center muffler.

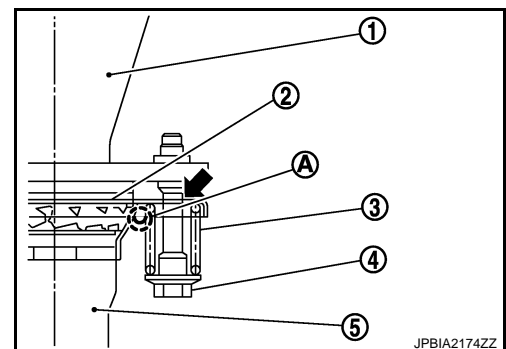

Inspection

INFOID:000000005491422

INSPECTION AFTER INSTALLATION

EXHAUST SYSTEM

< REMOVAL AND INSTALLATION >

- Check clearance between tail tube and rear bumper is even.
- With engine running, check exhaust tube joints for gas leakage and unusual noises.
- Check to ensure that mounting brackets and mounting rubbers are installed properly and free from undue stress. Improper installation could result in excessive noise and vibration.

A

EX

C

D

E

F

G

H

I

J

K

L

M

N

O

P