

# SECTION HAC

## HEATER & AIR CONDITIONING CONTROL SYSTEM

### CONTENTS

<b>AUTOMATIC AIR CONDITIONING</b>		
<b>BASIC INSPECTION</b> .....	5	
<b>DIAGNOSIS AND REPAIR WORK FLOW</b> .....	5	
Work Flow .....	5	
<b>INSPECTION</b> .....	8	
Description & Inspection .....	8	
<b>AUXILIARY MECHANISM</b> .....	10	
Temperature Setting Trimmer .....	10	
Inlet Port Memory Function .....	11	
<b>SYSTEM DESCRIPTION</b> .....	12	
<b>COMPRESSOR CONTROL FUNCTION</b> .....	12	
Description .....	12	
Component Parts Location .....	13	
Component Description .....	13	
<b>AUTOMATIC AIR CONDITIONING SYSTEM</b> ....	15	
System Diagram .....	15	
System Description .....	15	
Component Parts Location .....	24	
Component Description .....	24	
<b>DIAGNOSIS SYSTEM (A/C AUTO AMP.)</b> .....	26	
Diagnosis Description .....	26	
<b>DIAGNOSIS SYSTEM (BCM) (WITH INTELLI- GENT KEY SYSTEM)</b> .....	30	
<b>COMMON ITEM</b> .....	30	
COMMON ITEM : CONSULT-III Function (BCM - COMMON ITEM) .....	30	
<b>AIR CONDITIONER</b> .....	31	
AIR CONDITIONER : CONSULT-III Function (BCM - AUTO AIR CONDITIONER) .....	31	
<b>DIAGNOSIS SYSTEM (BCM) (WITHOUT IN- TELLIGENT KEY SYSTEM)</b> .....	33	
<b>COMMON ITEM</b> .....	33	
COMMON ITEM : CONSULT-III Function (BCM - COMMON ITEM) .....	33	
<b>AIR CONDITIONER</b> .....	33	
AIR CONDITIONER : CONSULT-III Function (BCM - AUTO AIR CONDITIONER) .....	34	
<b>DTC/CIRCUIT DIAGNOSIS</b> .....	35	
<b>AMBIENT SENSOR</b> .....	35	
Description .....	35	
Diagnosis Procedure .....	35	
Component Inspection .....	36	
<b>IN-VEHICLE SENSOR</b> .....	38	
Description .....	38	
Diagnosis Procedure .....	38	
Component Inspection .....	39	
<b>INTAKE SENSOR</b> .....	41	
Description .....	41	
Diagnosis Procedure .....	41	
Component Inspection .....	42	
<b>SUNLOAD SENSOR</b> .....	43	
Description .....	43	
Diagnosis Procedure .....	43	
Component Inspection .....	44	
<b>AIR MIX DOOR MOTOR</b> .....	46	
Description .....	46	
Diagnosis Procedure .....	46	
Component Inspection .....	47	
<b>MODE DOOR MOTOR</b> .....	49	
Description .....	49	
Diagnosis Procedure .....	49	
Component Inspection .....	50	
<b>INTAKE DOOR MOTOR</b> .....	52	
Description .....	52	
Diagnosis Procedure .....	52	

A  
B  
C  
D  
E  
F  
G  
H  
HAC  
J  
K  
L  
M  
N  
O  
P

Component Inspection .....	55	BCM (BODY CONTROL SYSTEM) (WITH INTELLIGENT KEY SYSTEM) : DTC Index .....	111
<b>BLOWER MOTOR .....</b>	<b>56</b>	<b>BCM (BODY CONTROL SYSTEM) (WITHOUT INTELLIGENT KEY SYSTEM) .....</b>	<b>112</b>
Description .....	56	BCM (BODY CONTROL SYSTEM) (WITHOUT INTELLIGENT KEY SYSTEM) : Reference Value .....	112
Component Function Check .....	56	BCM (BODY CONTROL SYSTEM) (WITHOUT INTELLIGENT KEY SYSTEM) : Wiring Diagram - BCM - .....	127
Diagnosis Procedure .....	56	BCM (BODY CONTROL SYSTEM) (WITHOUT INTELLIGENT KEY SYSTEM) : Fail-safe .....	131
Component Inspection .....	59	BCM (BODY CONTROL SYSTEM) (WITHOUT INTELLIGENT KEY SYSTEM) : DTC Inspection Priority Chart .....	132
<b>MAGNET CLUTCH .....</b>	<b>61</b>	BCM (BODY CONTROL SYSTEM) (WITHOUT INTELLIGENT KEY SYSTEM) : DTC Index .....	132
Description .....	61	<b>SYMPTOM DIAGNOSIS .....</b>	<b>134</b>
Component Function Check .....	61	<b>AUTOMATIC AIR CONDITIONING SYSTEM .....</b>	<b>134</b>
Diagnosis Procedure .....	61	Diagnosis Chart By Symptom .....	134
<b>A/C ON SIGNAL .....</b>	<b>62</b>	<b>INSUFFICIENT COOLING .....</b>	<b>135</b>
Component Function Check .....	62	Description .....	135
Diagnosis Procedure .....	62	Diagnosis Procedure .....	135
<b>BLOWER FAN ON SIGNAL .....</b>	<b>64</b>	<b>INSUFFICIENT HEATING .....</b>	<b>137</b>
Component Function Check .....	64	Description .....	137
Diagnosis Procedure .....	64	Diagnosis Procedure .....	137
<b>POWER SUPPLY AND GROUND CIRCUIT ....</b>	<b>66</b>	<b>COMPRESSOR DOSE DOT OPERATE .....</b>	<b>138</b>
<b>A/C AUTO AMP. ....</b>	<b>66</b>	Description .....	138
A/C AUTO AMP. : Diagnosis Procedure .....	66	Diagnosis Procedure .....	138
<b>BCM (BODY CONTROL SYSTEM) (WITH INTELLIGENT KEY SYSTEM) .....</b>	<b>67</b>	<b>MEMORY FUNCTION DOES NOT OPERATE. ....</b>	<b>140</b>
BCM (BODY CONTROL SYSTEM) (WITH INTELLIGENT KEY SYSTEM) : Diagnosis Procedure ....	67	Description .....	140
<b>BCM (BODY CONTROL SYSTEM) (WITHOUT INTELLIGENT KEY SYSTEM) .....</b>	<b>68</b>	Inspection Procedure .....	140
BCM (BODY CONTROL SYSTEM) (WITHOUT INTELLIGENT KEY SYSTEM) : Diagnosis Procedure .....	68	<b>PRECAUTION .....</b>	<b>141</b>
<b>A/C AUTO AMP. ....</b>	<b>70</b>	<b>PRECAUTIONS .....</b>	<b>141</b>
Description .....	70	Precaution for Supplemental Restraint System (SRS) "AIR BAG" and "SEAT BELT PRE-TENSIONER" .....	141
Component Function Check .....	70	Precaution Necessary for Steering Wheel Rotation after Battery Disconnect .....	141
Diagnosis Procedure .....	70	<b>REMOVAL AND INSTALLATION .....</b>	<b>143</b>
<b>ECU DIAGNOSIS INFORMATION .....</b>	<b>71</b>	<b>A/C CONTROL (A/C AUTO AMP.) .....</b>	<b>143</b>
<b>A/C AUTO AMP. ....</b>	<b>71</b>	Exploded View .....	143
Reference Value .....	71	Removal and Installation .....	143
Wiring Diagram - AUTOMATIC AIR CONDITIONING SYSTEM - .....	74	<b>AMBIENT SENSOR .....</b>	<b>144</b>
<b>BCM (BODY CONTROL MODULE) .....</b>	<b>82</b>	Exploded View .....	144
<b>BCM (BODY CONTROL SYSTEM) (WITH INTELLIGENT KEY SYSTEM) .....</b>	<b>82</b>	Removal and Installation .....	144
BCM (BODY CONTROL SYSTEM) (WITH INTELLIGENT KEY SYSTEM) : Reference Value .....	82	<b>IN-VEHICLE SENSOR .....</b>	<b>145</b>
BCM (BODY CONTROL SYSTEM) (WITH INTELLIGENT KEY SYSTEM) : Wiring Diagram - BCM .....	102	Exploded View .....	145
BCM (BODY CONTROL SYSTEM) (WITH INTELLIGENT KEY SYSTEM) : Fail-safe .....	107	Removal and Installation .....	145
BCM (BODY CONTROL SYSTEM) (WITH INTELLIGENT KEY SYSTEM) : DTC Inspection Priority Chart .....	109		



Description .....	217	<b>THERMO CONTROL AMPLIFIER .....</b>	<b>225</b>
Diagnosis Procedure .....	217	Exploded View .....	225
<b>INSUFFICIENT HEATING .....</b>	<b>218</b>	Removal and Installation .....	225
Description .....	218	<b>REFRIGERANT PRESSURE SENSOR .....</b>	<b>226</b>
Diagnosis Procedure .....	218	Exploded View .....	226
<b>COMPRESSOR DOSE DOT OPERATE .....</b>	<b>219</b>	Removal and Installation .....	226
Description .....	219	<b>BLOWER FAN RESISTOR .....</b>	<b>228</b>
Diagnosis Procedure .....	219	Exploded View .....	228
<b>PRECAUTION .....</b>	<b>221</b>	Removal and Installation .....	228
<b>PRECAUTIONS .....</b>	<b>221</b>	<b>INTAKE DOOR MOTOR .....</b>	<b>229</b>
Precaution for Supplemental Restraint System (SRS) "AIR BAG" and "SEAT BELT PRE-TEN- SIONER" .....	221	Exploded View .....	229
Precaution Necessary for Steering Wheel Rota- tion after Battery Disconnect .....	221	Removal and Installation .....	229
<b>REMOVAL AND INSTALLATION .....</b>	<b>223</b>	<b>DOOR CABLE .....</b>	<b>230</b>
<b>A/C CONTROL .....</b>	<b>223</b>	Exploded View .....	230
Exploded View .....	223	<b>MODE DOOR CABLE .....</b>	<b>231</b>
Removal and Installation .....	223	MODE DOOR CABLE : Removal and Installation.	231
		<b>AIR MIX DOOR CABLE .....</b>	<b>231</b>
		AIR MIX DOOR CABLE : Removal and Installation	. 231

# DIAGNOSIS AND REPAIR WORK FLOW

< BASIC INSPECTION >

[AUTOMATIC AIR CONDITIONING]

## BASIC INSPECTION

### DIAGNOSIS AND REPAIR WORK FLOW

Work Flow

INFOID:000000005490026

#### OVERALL SEQUENCE

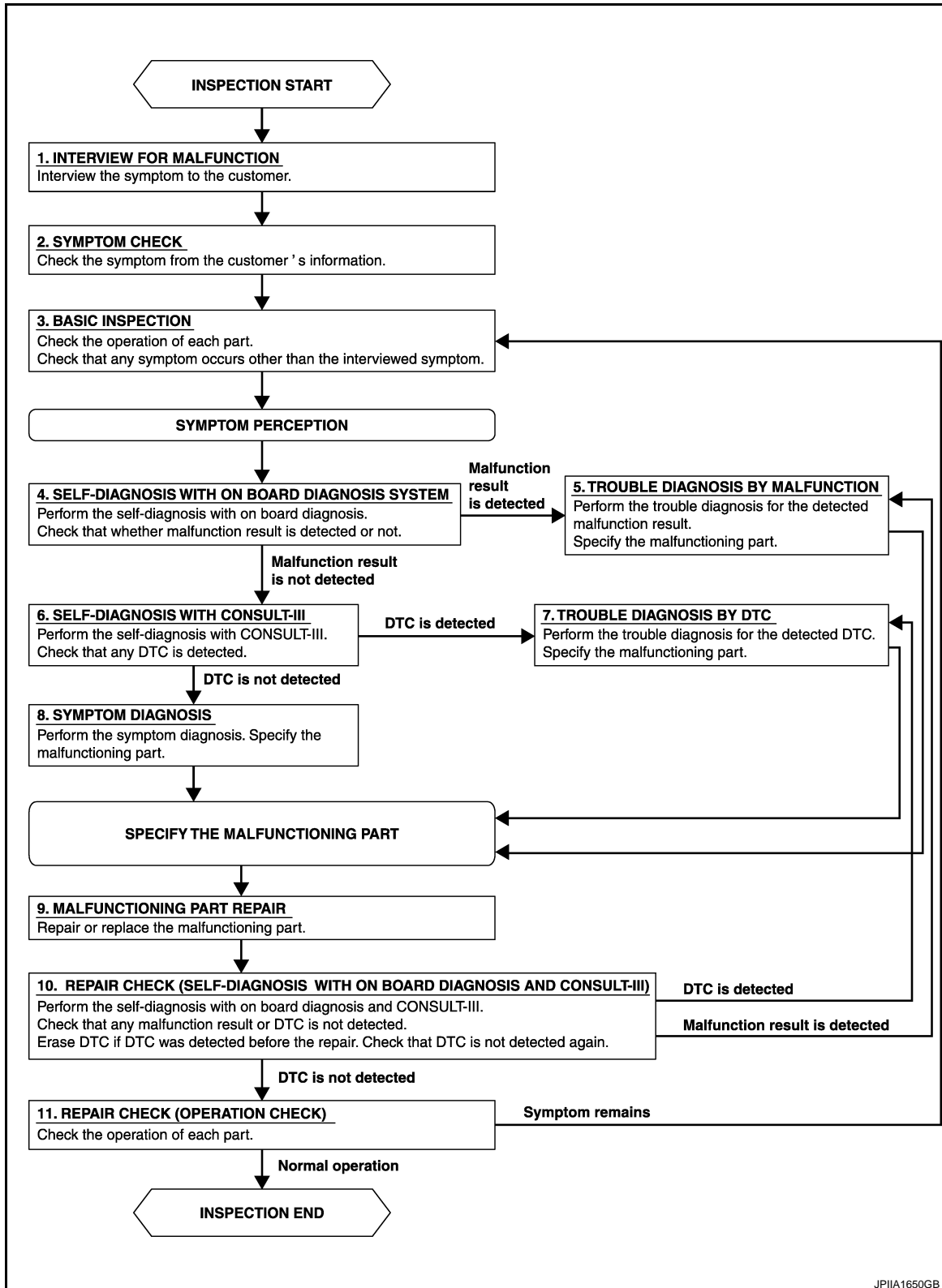

DETAILED FLOW

A  
B  
C  
D  
E  
F  
G  
H  
HAC  
J  
K  
L  
M  
N  
O  
P

# DIAGNOSIS AND REPAIR WORK FLOW

[AUTOMATIC AIR CONDITIONING]

< BASIC INSPECTION >

---

## 1. INTERVIEW FOR MALFUNCTION

---

Interview the symptom to the customer.

>> GO TO 2.

---

## 2. SYMPTOM CHECK

---

Check the symptom from the customer's information.

>> GO TO 3.

---

## 3. BASIC INSPECTION

---

Check the operation of each part. Check that any symptom occurs other than the interviewed symptom.

>> GO TO 4.

---

## 4. SELF-DIAGNOSIS WITH ON BOARD DIAGNOSIS SYSTEM

---

Perform the self-diagnosis with on board diagnosis. Check that whether malfunction result is detected or not. Refer to [HAC-26. "Diagnosis Description"](#).

Is any malfunction result detected?

YES >> GO TO 5.

NO >> GO TO 6.

---

## 5. TROUBLE DIAGNOSIS BY MALFUNCTION

---

Perform the trouble diagnosis for the detected malfunction result. Specify the malfunction part.

>> GO TO 6.

---

## 6. SELF-DIAGNOSIS WITH CONSULT-III

---

Perform the self-diagnosis with CONSULT-III. Check that any DTC is detected.

Is any DTC detected?

YES >> GO TO 7.

NO >> GO TO 8.

---

## 7. TROUBLE DIAGNOSIS BY DTC

---

Perform the trouble diagnosis for the detected DTC. Specify the malfunctioning part.

>> GO TO 8.

---

## 8. SYMPTOM DIAGNOSIS

---

Perform the symptom diagnosis. Specify the malfunctioning part.

>> GO TO 9.

---

## 9. MALFUNCTION PART REPAIR

---

Repair or replace the malfunctioning part.

>> GO TO 10.

---

## 10. REPAIR CHECK (SELF-DIAGNOSIS WITH ON BOARD DIAGNOSIS AND CONSULT-III)

---

Perform the self-diagnoses with on board diagnosis and CONSULT-III. Check that any DTC or malfunction result is not detected. Erase DTC if DTC is detected before the repair. Check that DTC is not detected again.

Is any or malfunction result or DTC detected?

YES-1 >> If malfunction result is detected, GO TO 5.

YES-2 >> If DTC is detected, GO TO 7.

NO >> GO TO 11.

# DIAGNOSIS AND REPAIR WORK FLOW

< BASIC INSPECTION >

[AUTOMATIC AIR CONDITIONING]

## 11. REPAIR CHECK (OPERATION CHECK)

Check the operation of each part.

Does it operate normally?

YES >> INSPECTION END

NO >> GO TO 3.

A

B

C

D

E

F

G

H

HAC

J

K

L

M

N

O

P

## INSPECTION

## Description &amp; Inspection

INFOID:000000005490027

## DESCRIPTION

The purpose of the operational check is to check that the individual system operates normally.

**Check condition : Engine running at normal operating temperature.**

**1.CHECK MEMORY FUNCTION**

1. Start the engine.
2. Set the temperature to 32°C (90°F) by operating the temperature control switch.
3. Press OFF switch.
4. Turn ignition switch OFF.
5. Turn ignition switch ON.
6. Press AUTO switch.
7. Check that the set temperature is maintained.

Is the inspection result normal?

- YES >> GO TO 2.  
 NO >> Memory function malfunction. Refer to [HAC-140, "Inspection Procedure"](#).

**2.CHECK BLOWER MOTOR**

1. Start the engine.
2. Operate the fan control switch. Check that the fan speed changes. Check the operation for all fan speeds.
3. Leave blower on maximum speed.

Is the inspection result normal?

- YES >> GO TO 3.  
 NO >> Blower motor system malfunction. Refer to [HAC-56, "Diagnosis Procedure"](#).

**3.CHECK DISCHARGE AIR**

1. Operate MODE switch and DEF switch to each position.
2. Check that the air outlets change according to each indicated air outlet by placing a hand in front of the outlets. Refer to [VTL-2, "System Description"](#).

Is the inspection result normal?

- YES >> GO TO 4.  
 NO >> Mode door system malfunction. Refer to [HAC-49, "Diagnosis Procedure"](#).

**4.CHECK INTAKE AIR**

1. Press REC switch to set the air outlet to recirculation.
2. The REC indicator turns ON.
3. Listen to intake sound and confirm air inlets change.
4. Press FRE switch again to set the air outlet to fresh air intake.
5. The FRE indicator turns ON.
6. Listen to intake sound and confirm air inlets change.

Is the inspection result normal?

- YES >> GO TO 5.  
 NO >> Intake door system malfunction. Refer to [HAC-52, "Diagnosis Procedure"](#).

**5.CHECK A/C SWITCH**

1. Press the A/C switch.
2. Check that the indicator of the A/C switch turns ON. Check visually and by sound that the compressor operates.
3. Press the A/C switch again.
4. Check that the indicator of the A/C switch turns OFF. Check that the compressor stops.

Is the inspection result normal?

- YES >> GO TO 6.  
 NO >> Magnet clutch system malfunction. Refer to [HAC-61, "Diagnosis Procedure"](#).



# INSPECTION

< BASIC INSPECTION >

[AUTOMATIC AIR CONDITIONING]

## 6. CHECK DISCHARGE AIR TEMPERATURE

Operate the temperature control switch. Check that the discharge air temperature changes.

Is the inspection result normal?

YES >> GO TO 7.

NO >> Air mix door system malfunction. Refer to [HAC-46, "Diagnosis Procedure"](#).

## 7. CHECK TEMPERATURE DECREASE

1. Operate the compressor.
2. Operate the temperature control switch to lower temperature setting at 18°C (60°F).
3. Check that the cool air blows from the outlets.

Is the inspection result normal?

YES >> GO TO 8.

NO >> Insufficient cooling. Refer to [HAC-135, "Diagnosis Procedure"](#).

## 8. CHECK TEMPERATURE INCREASE

1. Turn temperature control switch to raise temperature setting at 32°C (90°F) after warming up the engine.
2. Check that warm air blows from outlets.

Is the inspection result normal?

YES >> GO TO 9.

NO >> Insufficient heating. Refer to [HAC-137, "Diagnosis Procedure"](#).

## 9. CHECK AUTO MODE

1. Press AUTO switch to confirm that "AUTO" is indicated on the display.
2. Operate the temperature control switch to check that the fan speed or air outlet changes (the air flow temperature or fan speed varies depending on the ambient temperature, in-vehicle temperature, and set temperature).

Is the inspection result normal?

YES >> INSPECTION END

NO >> Refer to [HAC-134, "Diagnosis Chart By Symptom"](#) and perform the appropriate diagnosis.

A  
B  
C  
D  
E  
F  
G  
H  
J  
K  
L  
M  
N  
O  
P

HAC

## AUXILIARY MECHANISM

### Temperature Setting Trimmer

INFOID:000000005490028

#### DESCRIPTION

If the temperature felt by the customer is different than the air flow temperature controlled by the temperature setting, the A/C auto amp. control temperature can be adjusted to compensate for the temperature setting.

#### OPERATING PROCEDURES

1. Begin self-diagnosis STEP 5 mode. Refer to [HAC-26. "Diagnosis Description"](#).
2. Press fan control switch (up: +) to enter the set temperature setting trimmer mode from STEP 5, and then display shows "0°C (0°F)".
3. The indication temperature will be changed by 1°C (1°F) in range of -3°C (-6°F) to +3°C (+6°F) by pressing the temperature control switch each time.

#### USA models

Temperature control switch operation	Display	Correction (°F)
▲ 6 time pressing	6	+6
▲ 5 time pressing	5	+5
▲ 4 time pressing	4	+4
▲ 3 time pressing	3	+3
▲ 2 time pressing	2	+2
▲ 1 time pressing	1	+1
Initial status	0	0
▼ 1 time pressing	AUTO 1	-1
▼ 2 time pressing	AUTO 2	-2
▼ 3 time pressing	AUTO 3	-3
▼ 4 time pressing	AUTO 4	-4
▼ 5 time pressing	AUTO 5	-5
▼ 6 time pressing	AUTO 6	-6

#### Canada models

Temperature control switch operation	Display	Correction (°C)
▲ 3 time pressing	3	+3
▲ 2 time pressing	2	+2
▲ 1 time pressing	1	+1
Initial status	0	0
▼ 1 time pressing	AUTO 1	-1
▼ 2 time pressing	AUTO 2	-2
▼ 3 time pressing	AUTO 3	-3

#### NOTE:

- When -3°C (-6°F) is corrected on the temperature setting set as 25°C (75°F), the temperature controlled by A/C auto amp. is 25°C (75°F) - 3°C (6°F) = 22.0°C (69°F) and the temperature becomes lower than the temperature setting.
- When the battery cable is disconnected from the negative terminal or when the battery voltage becomes 10 V or less, the setting of the difference between the set temperature and control temperature may be cancelled.

Inlet Port Memory Function

INFOID:000000005490029

DESCRIPTION

- Inlet port setting can be memorized when ignition switch is turned OFF.
- Inlet port setting can be selected from FRE (fresh air intake), REC (recirculation), or “Do not perform the memory” when ignition switch is turned ON.

OPERATING PROCEDURES

1. Begin self-diagnosis STEP 5 mode. Refer to [HAC-26, "Diagnosis Description"](#).
2. Press fan control switch (up: +) two times to change the mode to the temperature setting trimmer from self-diagnosis STEP 5, and then the display shows “70”.
3. The setting of inlet port memory function can be selected from “70” to “73” by pressing the FRE switch.

FRE switch operation	Display	Memory function	
		Manual REC	Manual FRE
—	70*	Shall be memorized	Shall not be memorized
1 time pressing	71	Shall not be memorized	Shall not be memorized
2 time pressing	72	Shall be memorized	Shall be memorized
3 time pressing	73	Shall not be memorized	Shall be memorized

\*: Initial status

**NOTE:**

- When FRE switch is pressed four times, display shows "70" again.
- When the battery cable is disconnected from the negative terminal or when the battery voltage becomes 10 V or less, the setting of the inlet port memory function may be cancelled.

A  
B  
C  
D  
E  
F  
G  
H  
J  
K  
L  
M  
N  
O  
P

HAC

# COMPRESSOR CONTROL FUNCTION

< SYSTEM DESCRIPTION >

[AUTOMATIC AIR CONDITIONING]

## SYSTEM DESCRIPTION

### COMPRESSOR CONTROL FUNCTION

Description

INFOID:000000005490030

PRINCIPLE OF OPERATION

Functional Circuit Diagram

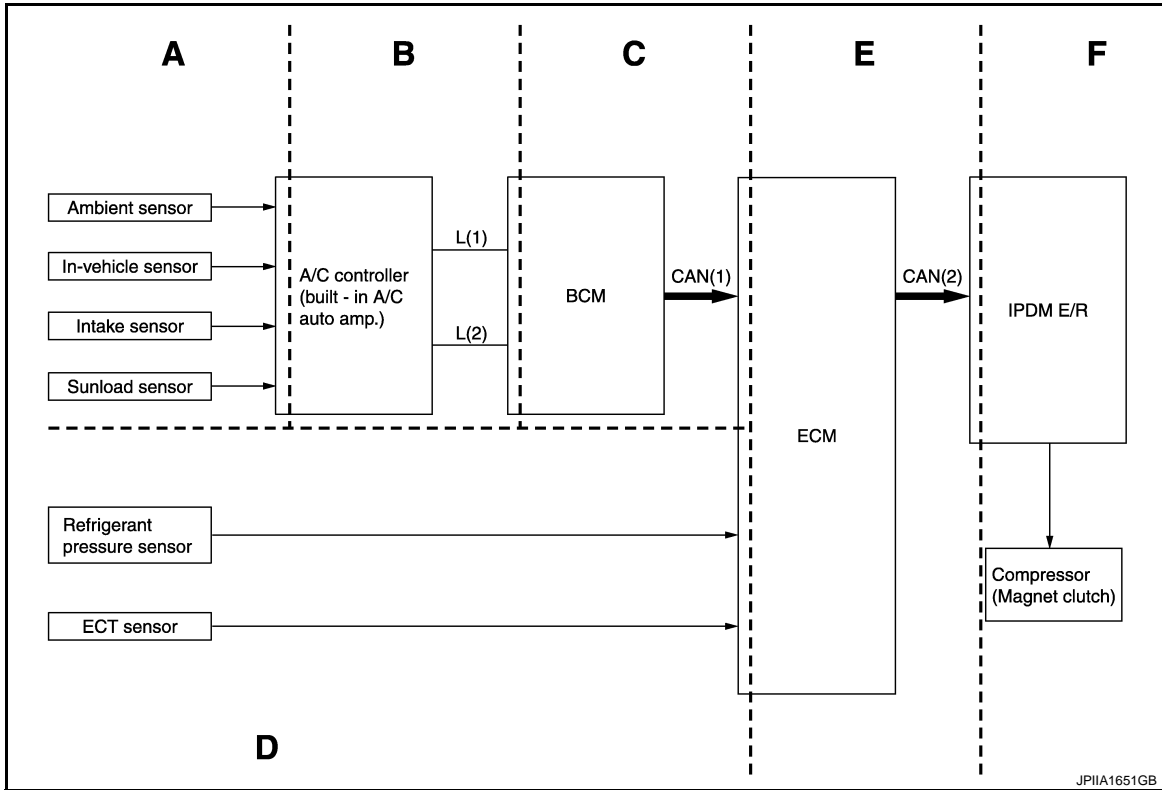

L (1) : Fan ON signal

CAN (1) : A/C ON switch signal  
: Blower fan ON signal

L (2) : A/C switch signal

CAN (2) : A/C compressor request signal

Functional Initial Inspection Chart

×: Applicable

Control unit	Diagnosis item	Location					
		A	B	C	D	E	F
A/C auto amp.	On board self-diagnosis	×	—	—	—	—	—
BCM	Ⓟ "BCM-AIR COND"	Self-diagnosis	—	—	×	—	—
		Data monitor	—	×	—	—	—
ECM	Ⓟ "ENGINE"	Self-diagnosis (CAN communication line)	—	—	—	×	—
		Data monitor	—	—	×	×	—
IPDM E/R	Ⓟ "IPDM E/R"	Self-diagnosis (CAN communication line)	—	—	—	—	×
		Data monitor	—	—	—	—	×
	Auto active test	—	—	—	—	—	×

# COMPRESSOR CONTROL FUNCTION

< SYSTEM DESCRIPTION >

[AUTOMATIC AIR CONDITIONING]

## Component Parts Location

INFOID:000000005490031

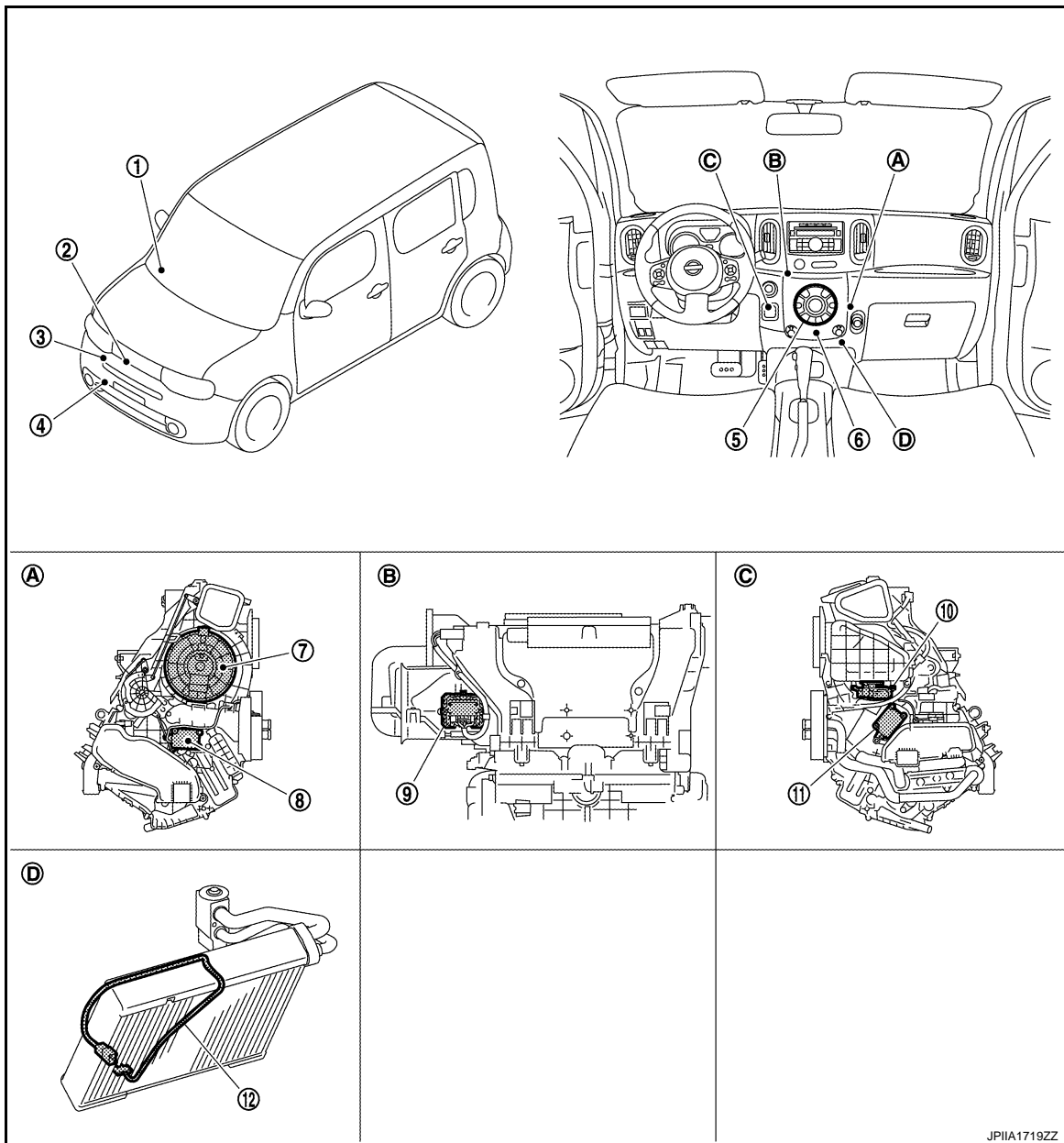

- |   |   |  |
|---|---|--|
| 1. Sunload sensor                                 | 2. Ambient sensor                           | 3. Magnet clutch                             |
| 4. Refrigerant pressure sensor                    | 5. A/C control (A/C auto amp.)              | 6. In-vehicle sensor                         |
| 7. Blower motor                                   | 8. Mode door motor                          | 9. Power transistor                          |
| 10. Intake door motor                             | 11. Air mix door motor                      | 12. Intake sensor                            |
| A. Located in the right side of A/C unit assembly | B. Located in the back of A/C unit assembly | C. Located in left side of A/C unit assembly |
| D. Located on the evaporator                      |   |  |

## Component Description

INFOID:000000005490032

Component	Description
Sunload sensor	<a href="#">HAC-43, "Description"</a>
Ambient sensor	<a href="#">HAC-35, "Description"</a>

# COMPRESSOR CONTROL FUNCTION

< SYSTEM DESCRIPTION >

[AUTOMATIC AIR CONDITIONING]

Component	Description
Magnet clutch	<a href="#">HAC-61. "Description"</a>
Refrigerant pressure sensor	<a href="#">EC-415. "Description"</a>
A/C control (A/C auto amp.)	<a href="#">HAC-70. "Description"</a>
In-vehicle sensor	<a href="#">HAC-38. "Description"</a>
Blower motor	<a href="#">HAC-56. "Description"</a>
Air mix door motor	<a href="#">HAC-46. "Description"</a>
Power transistor	<a href="#">HAC-56. "Description"</a>
Intake sensor	<a href="#">HAC-41. "Description"</a>
Mode door motor	<a href="#">HAC-49. "Description"</a>
Intake door motor	<a href="#">HAC-52. "Description"</a>

# AUTOMATIC AIR CONDITIONING SYSTEM

< SYSTEM DESCRIPTION >

[AUTOMATIC AIR CONDITIONING]

## AUTOMATIC AIR CONDITIONING SYSTEM

### System Diagram

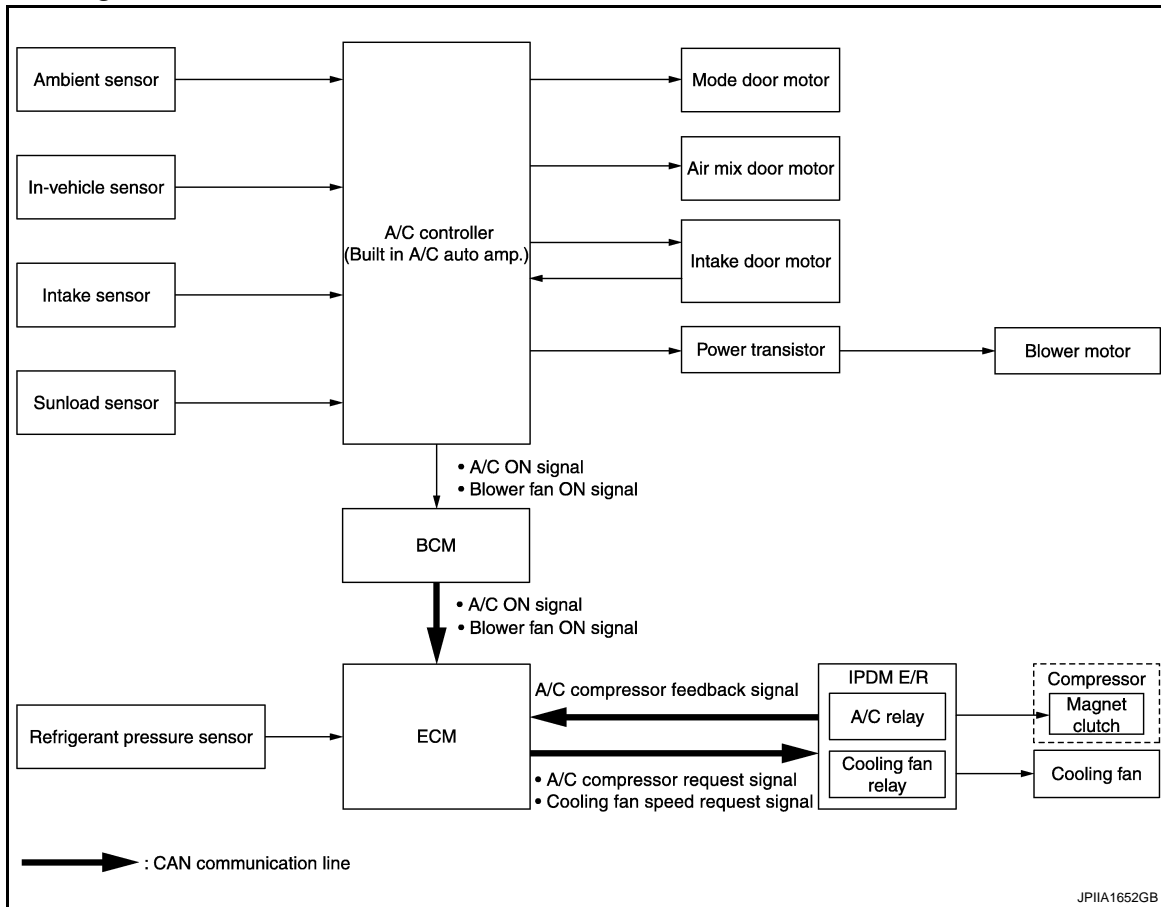

### System Description

INFOID:000000005490034

#### OUTLINE

- Automatic air conditioner system is controlled by each function of A/C auto amp., ECM, BCM and IPDM E/R.

Control by A/C auto amp.

- Air outlet control
- Temperature control
- Air inlet control
- Air flow control
- Compressor control
- Door motor control (LCU communication control)

Control by BCM

- Compressor control

Control by ECM

- Cooling fan control. Refer to [EC-61. "System Description"](#).
- Air conditioning cut control. Refer to [EC-45. "System Description"](#).
- Compressor control

Control by IPDM E/R

- Relay control. Refer to [PCS-4. "System Description"](#) (WITH I-KEY) or [PCS-35. "System Description"](#) (WITHOUT I-KEY).
- Cooling fan control. Refer to [PCS-4. "System Description"](#) (WITH I-KEY) or [PCS-35. "System Description"](#) (WITHOUT I-KEY).
- Each A/C system can be operated by A/C controller (built-in A/C auto amp.).

# AUTOMATIC AIR CONDITIONING SYSTEM

< SYSTEM DESCRIPTION >

[AUTOMATIC AIR CONDITIONING]

## OPERATION

Controller (A/C Control)

For USA

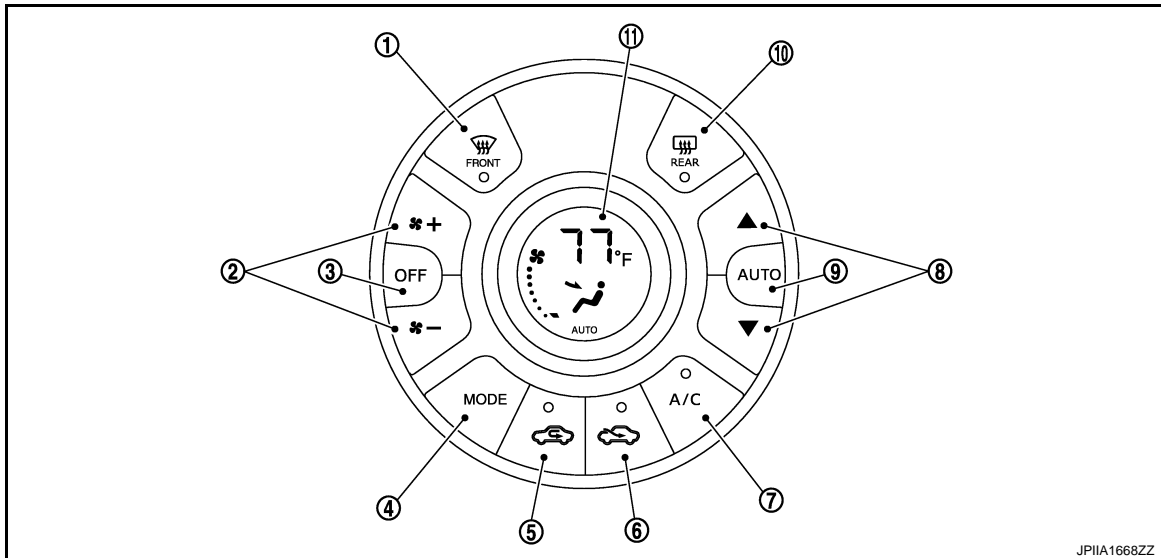

- |                                 |                               |                |
|---------------------------------|-------------------------------|----------------|
| 1. DEF switch                   | 2. Fan control switch         | 3. OFF switch  |
| 4. MODE switch                  | 5. REC switch                 | 6. FRE switch  |
| 7. A/C switch                   | 8. Temperature control switch | 9. AUTO switch |
| 10. Rear window defogger switch | 11. A/C display               |                |

For Canada

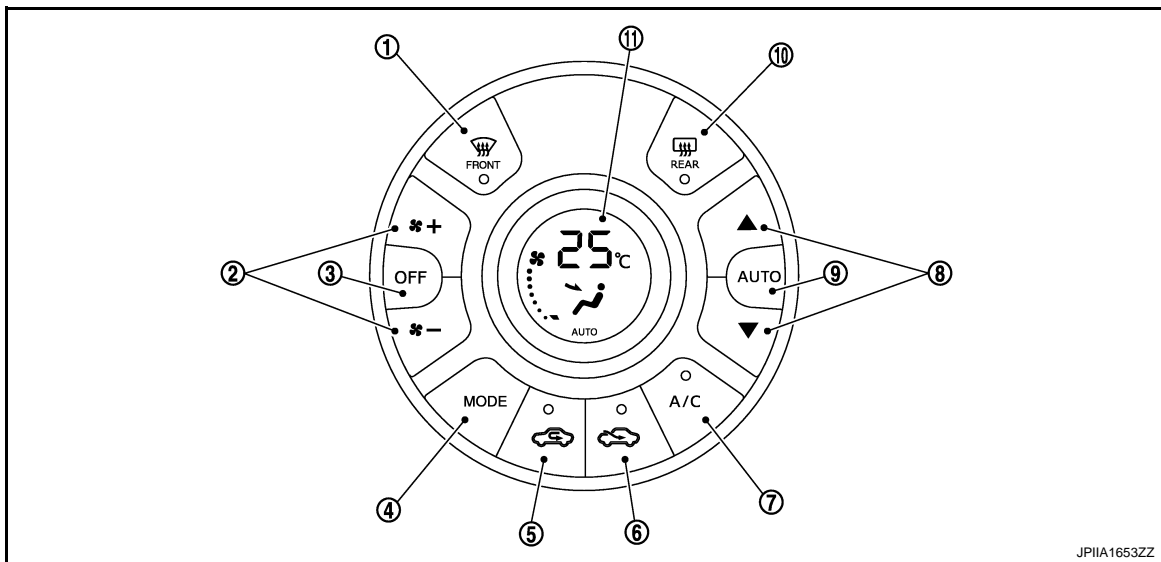

- |                                 |                               |                |
|---------------------------------|-------------------------------|----------------|
| 1. DEF switch                   | 2. Fan control switch         | 3. OFF switch  |
| 4. MODE switch                  | 5. REC switch                 | 6. FRE switch  |
| 7. A/C switch                   | 8. Temperature control switch | 9. AUTO switch |
| 10. Rear window defogger switch | 11. A/C display               |                |

Switch Operation



# AUTOMATIC AIR CONDITIONING SYSTEM

< SYSTEM DESCRIPTION >

[AUTOMATIC AIR CONDITIONING]

DEF switch	<ul style="list-style-type: none"> <li>• DEF switch indicator is turned ON ⇔ OFF by pressing DEF switch each time.</li> <li>• When DEF switch is operated while air conditioner system is activated, the system becomes the following states.                             <ul style="list-style-type: none"> <li>- Compressor: ON</li> <li>- Air inlet: Fresh air intake</li> <li>- Blower fan: Auto control (if blower fan is set to manual mode before pressing DEF switch, it becomes manual mode)</li> </ul> </li> <li>- When DEF mode set to OFF, air conditioner system returns previous condition which is set to DEF mode.</li> <li>• When DEF switch is operated while air conditioner system is inactivation, the system becomes the following states.                             <ul style="list-style-type: none"> <li>- Air conditioner system: ON</li> <li>- Compressor: ON</li> <li>- Air inlet: Fresh air intake</li> <li>- Blower fan: Auto control</li> </ul> </li> <li>• When DEF mode set to OFF, all air conditioner system is OFF.</li> </ul> <p><b>NOTE:</b> When DEF mode is set to ON during auto control of air conditioner system, the system becomes manual control.</p>	A B C D E
Fan control switch	<p>Fan speed is selected within a range between 1st – 7th speed by pressing this switch.</p> <p><b>NOTE:</b></p> <ul style="list-style-type: none"> <li>• When air conditioner system is OFF, air conditioner system is set to ON by pressing this switch.</li> <li>• When fan control switch is operated during auto control of air conditioner system, the system becomes manual mode.</li> </ul>	F G
OFF switch	<ul style="list-style-type: none"> <li>• Air conditioner system is turned OFF by pressing this switch.</li> <li>• When the air conditioner system becomes OFF, air inlet and outlet are set as follows:                             <ul style="list-style-type: none"> <li>- Air inlet: FRE (except REC is manually selected)</li> <li>- Air outlet: FOOT</li> </ul> </li> </ul>	H
Mode switch	<ul style="list-style-type: none"> <li>• Mode position is changed in order of VENT ⇒ B/L ⇒ FOOT ⇒ D/F ⇒ VENT by operating this switch each time.</li> <li>• When D/F is selected while blower motor is activated, air conditioner system becomes the following states.                             <ul style="list-style-type: none"> <li>- Compressor: ON</li> <li>- Air inlet: Fresh air intake</li> </ul> </li> </ul> <p><b>NOTE:</b> When MODE switch is operated during auto control of air conditioner system, the system becomes manual mode.</p>	J K
REC switch	<p>Air inlet is selected to recirculation (REC) by pressing this switch.</p> <ul style="list-style-type: none"> <li>• REC indicator ON</li> <li>• FRE indicator OFF</li> </ul> <p><b>NOTE:</b></p> <ul style="list-style-type: none"> <li>• Even if the air conditioner system is OFF, air inlet can be selected.</li> <li>• When mode position is D/F or DEF, recirculation (REC) cannot be selected.</li> <li>• When REC switch is selected, the compressor is turned ON.</li> <li>• When REC indicator is ON, pressing the REC switch for approximately 1.5 seconds or more, and then the FRE and REC switch indicators blink twice and the system is switched to the automatic control.</li> </ul>	L M
FRE switch	<p>Air inlet is selected to fresh air intake (FRE) by pressing this switch.</p> <ul style="list-style-type: none"> <li>• FRE indicator: ON</li> <li>• REC indicator: OFF</li> </ul> <p><b>NOTE:</b></p> <ul style="list-style-type: none"> <li>• Even if the air conditioner system is OFF, air inlet can be selected.</li> <li>• When mode position is D/F or DEF, air inlet is set to FRE forcibly.</li> <li>• When FRE indicator is ON, pressing the FRE switch for approximately 1.5 seconds or more, and then the FRE and REC switch indicators blink twice and the system is switched to the automatic control.</li> </ul>	N O P
Temperature control switch	<p>Setting temperature is selected within a range between 18°C (60°F) – 32°C (90°F) by pressing this switch.</p> <ul style="list-style-type: none"> <li>• ▲ : Increase</li> <li>• ▼ : Decrease</li> </ul> <p><b>NOTE:</b> Even if air conditioner system is OFF, setting temperature can be selected by pressing these switch.</p>	

HAC

# AUTOMATIC AIR CONDITIONING SYSTEM

## < SYSTEM DESCRIPTION >

## [AUTOMATIC AIR CONDITIONING]

A/C switch	The compressor control (switch indicator) is turned between ON ↔ OFF by pressing this switch each time only when blower fan is activated. <b>NOTE:</b> <ul style="list-style-type: none"> <li>When blower fan is inactivation, compressor control can not be turned ON.</li> <li>When mode position is D/F or DEF, A/C switch is turned ON forcibly.</li> </ul>
Rear window defogger switch	Rear window defogger (switch indicator) is turned between ON ↔ OFF by pressing this switch each time. Rear window defogger system details. Refer to <a href="#">DEF-4. "System Description"</a> .

### AIR OUTLET CONTROL

- While air outlet is in automatic control, A/C auto amp. selects the mode door position depending on a target air mix door angle and outlet air temperature calculated from sunload.
- If ambient temperature is excessively low, D/F is selected to prevent windshield fogging when air outlet is set to FOOT.

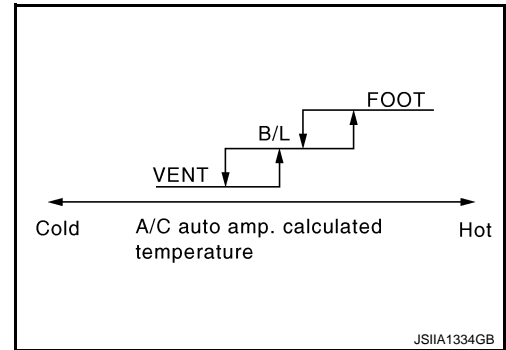

### TEMPERATURE CONTROL

- When ignition switch is in the ON position, A/C auto amp. always automatically controls temperature regardless of air conditioner operational state.
- A/C auto amp. calculates the target air mix door opening angle depending on set temperature, in-vehicle temperature, ambient temperature, and sunload.
- Air mix door is controlled depending on the comparison of current air mix door opening angle and target air mix door opening angle.
- Regardless of in-vehicle temperature, ambient temperature, and sunload, air mix door is fixed at the fully cold position when set temperature is 18°C (60°F), and at the fully hot position when set temperature is 32°C (90°F).

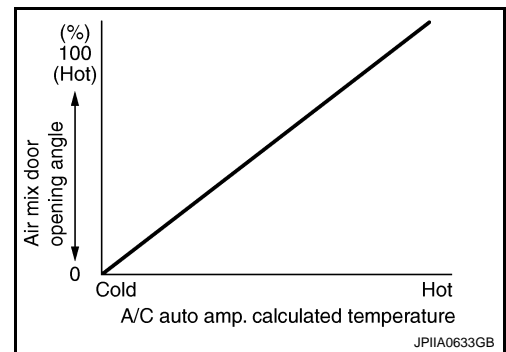

### AIR INLET FUNCTION

- While air inlet is in automatic control, A/C auto amp. selects air inlet (fresh air intake, 20% fresh air intake, or recirculation) depending on set temperature, in-vehicle temperature, and ambient temperature.
- Air inlet is fixed to 80% FRE, only when the conditions are satisfied as follows:
  - Air inlet is FOOT or D/F
  - Ambient temperature is 2°C (36°F) or less
  - Maximum fan speed

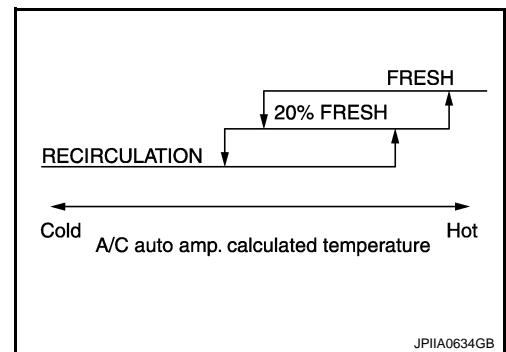

### AIR FLOW CONTROL

#### Description

- A/C auto amp. changes duty ratio of blower motor drive signal and controls air flow continuously. When air flow is increased, duty ratio of blower motor drive signal gradually increases to prevent a sudden increase in air flow.
- In addition to manual control and automatic control, air flow control is composed of starting fan speed control, low coolant temperature starting control, high in-vehicle temperature starting control, and blower speed control at door motor operation.

#### Automatic Air Flow Control

- A/C auto amp. decides target air flow depending on target air mix door opening angle.

# AUTOMATIC AIR CONDITIONING SYSTEM

## [AUTOMATIC AIR CONDITIONING]

### < SYSTEM DESCRIPTION >

- A/C auto amp. changes duty ratio of blower motor drive signal and controls air flow continuously so that air flow matches to target air flow.
- When air outlet is VENT or B/L, the minimum air flow is changed depending on sunload.

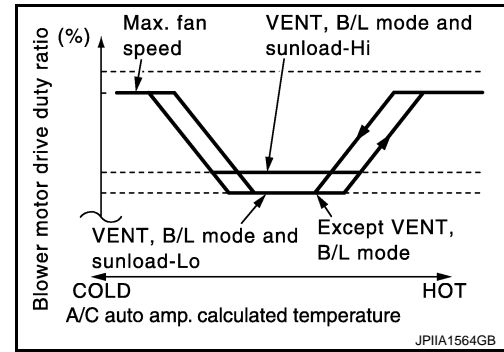

### Starting Fan Speed Control

When blower motor is activated, A/C auto amp. gradually increases duty ratio of blower fan drive signal to prevent a sudden increase in discharge air flow. ( $T_1 - T_2 =$  approximately 10 seconds)

#### NOTE:

Do not perform the starting air flow control when the discharge outlet is set to DEF.

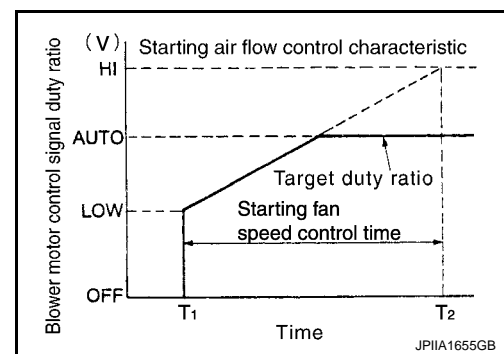

### Low Coolant Temperature Starting Control

If the engine coolant temperature is 56°C (133°F) or less, to prevent a cold discharged air flow, A/C auto amp. suspends blower motor activation for the maximum 150 seconds depending on target air mix door opening angle. After this, blower fan drive signal is increased gradually, and blower motor is activated.

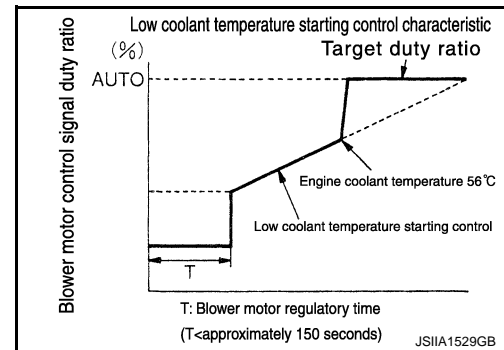

### Fan speed Control at Door Motor Operation

When mode door motor is activated while air flow is more than the specified value, A/C auto amp. reduces temporarily fan speed so that mode door moves smoothly.

### High In-vehicle Temperature Starting Control

When evaporator temperature is high [intake air temperature sensor value is 35°C (95°F) or more], to prevent a hot discharged air flow, A/C auto amp. suspends blower motor activation for approximately 3 seconds so that evaporator is cooled by refrigerant.

## COMPRESSOR CONTROL

### Description

- When the compressor activation condition is satisfied while blower motor is activated, A/C auto amp. transmits A/C ON signal and blower fan ON signal to BCM.
- BCM transmits A/C ON signal and blower fan ON signal to ECM via CAN communication.
- ECM judges that the compressor can be activated depending on each sensors state (refrigerant pressure sensor signal, throttle opening angle sensor signal, and others). And transmits A/C relay control signal to IPDM E/R via CAN communication.
- IPDM E/R turns A/C relay ON and activates the compressor depending on request from ECM.

# AUTOMATIC AIR CONDITIONING SYSTEM

[AUTOMATIC AIR CONDITIONING]

## < SYSTEM DESCRIPTION >

### Compressor Protection Control at Pressure Malfunction

When high-pressure side value that is detected by refrigerant pressure sensor is as per the following state, ECM requests IPDM E/R to turn A/C relay OFF and stops the compressor.

- 3.12 MPa (31.8 kg/cm<sup>2</sup>, 452 psi) or more (When the engine speed is less than 1,500 rpm)
- 2.74 MPa (27.9 kg/cm<sup>2</sup>, 397 psi) or more (When the engine speed is 1,500 rpm or more)
- 0.14 MPa (1.4 kg/cm<sup>2</sup>, 20 psi) or less

### Compressor Oil Circulation Control

When the engine starts while the engine coolant temperature is 56°C (133°F) or less, ECM activates the compressor for approximately 6 seconds and circulates the compressor lubricant once.

### Low Temperature Protection Control

When intake sensor detects that evaporator surface temperature is 2°C (36°F) or less, A/C auto amp. requests ECM to turn the compressor OFF, and stops the compressor.

When the air temperature returns to 3.5°C (38°F) or more, the compressor is activated.

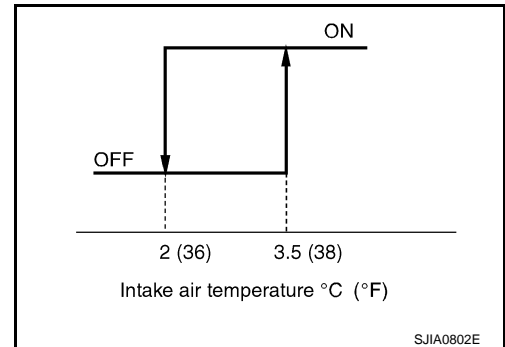

### Operating Rate Control

When set temperature is other than fully cold or air outlet is "VENT", "B/L" or "FOOT" A/C auto amp. controls the compressor activation depending on ambient temperature.

### Air Conditioner Cut Control

When the engine is running in excessively high load condition, ECM requests IPDM E/R to turn A/C relay OFF, and stops the compressor. Refer to [EC-45. "System Description"](#) for details.

## DOOR MOTOR CONTROL

### Mode Door Motor

The A/C auto amp. receives data from each sensors. When a drive signal is input from A/C auto amp. to door motor, a step motor built into the door motor rotates according to the drive signal, and then stops at the position of target door.

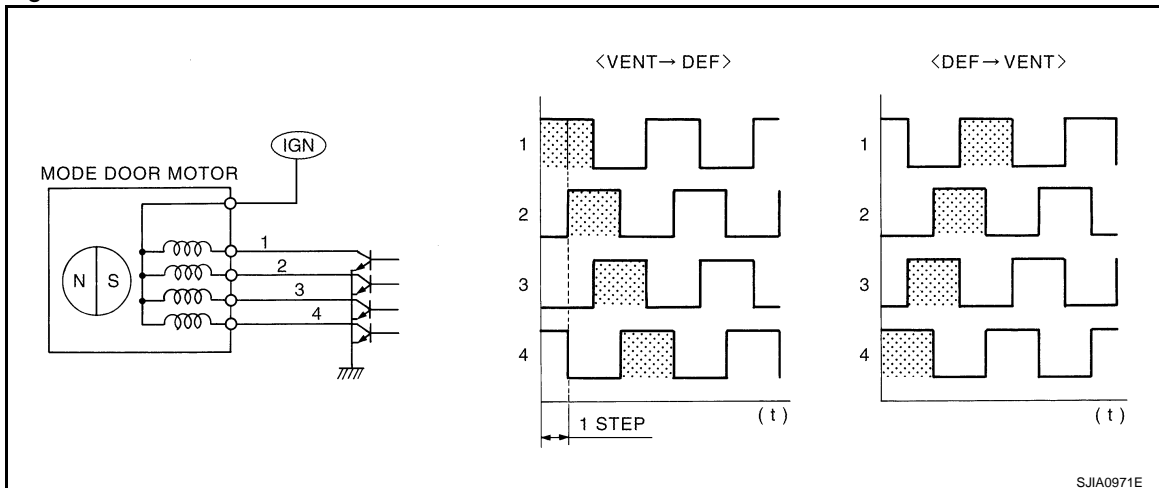

### Air Mix Door Motor

# AUTOMATIC AIR CONDITIONING SYSTEM

## [AUTOMATIC AIR CONDITIONING]

### < SYSTEM DESCRIPTION >

The A/C auto amp. receives data from each sensors. When a drive signal is input from A/C auto amp. to door motor, a step motor built into the door motor rotates according to the drive signal, and then stops at the position of target door.

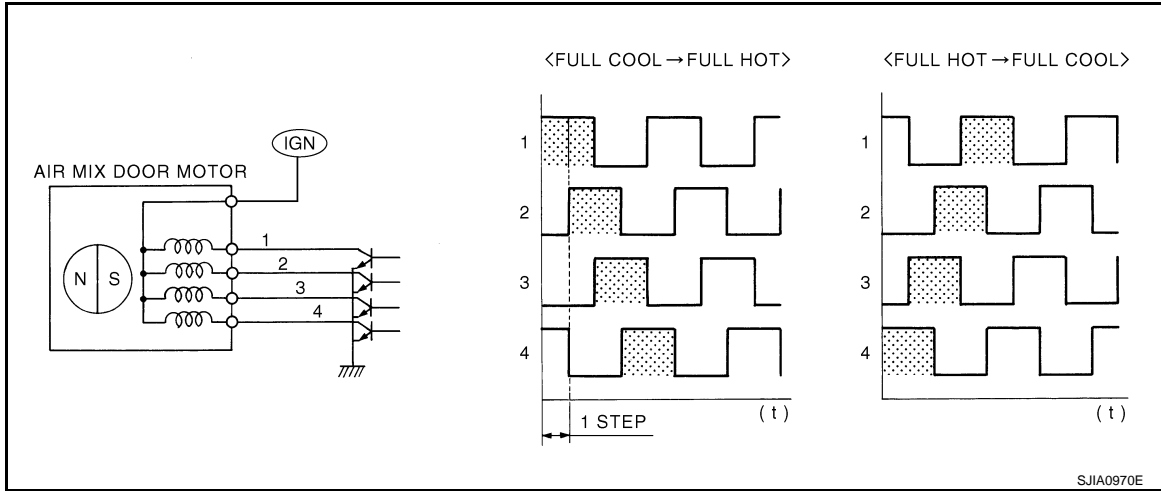

### Intake Door Motor

The A/C auto amp. receives data from each sensor, and converts them to control signal. The A/C auto amp. sends the control signal to Intake door motor. When intake door motor receives the control signal, intake door is moved to appropriate position by PBR opening angle indication signal.

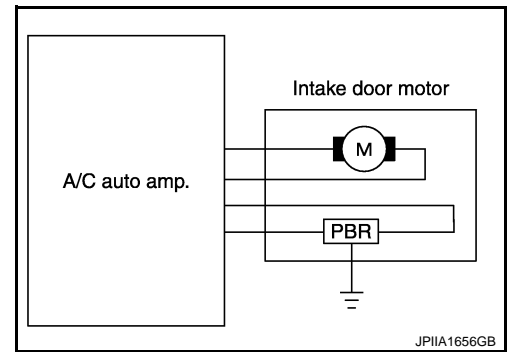

### SWITCHES AND THEIR CONTROL FUNCTIONS

A  
B  
C  
D  
E  
F  
G  
H  
HAC  
J  
K  
L  
M  
N  
O  
P

# AUTOMATIC AIR CONDITIONING SYSTEM

< SYSTEM DESCRIPTION >

[AUTOMATIC AIR CONDITIONING]

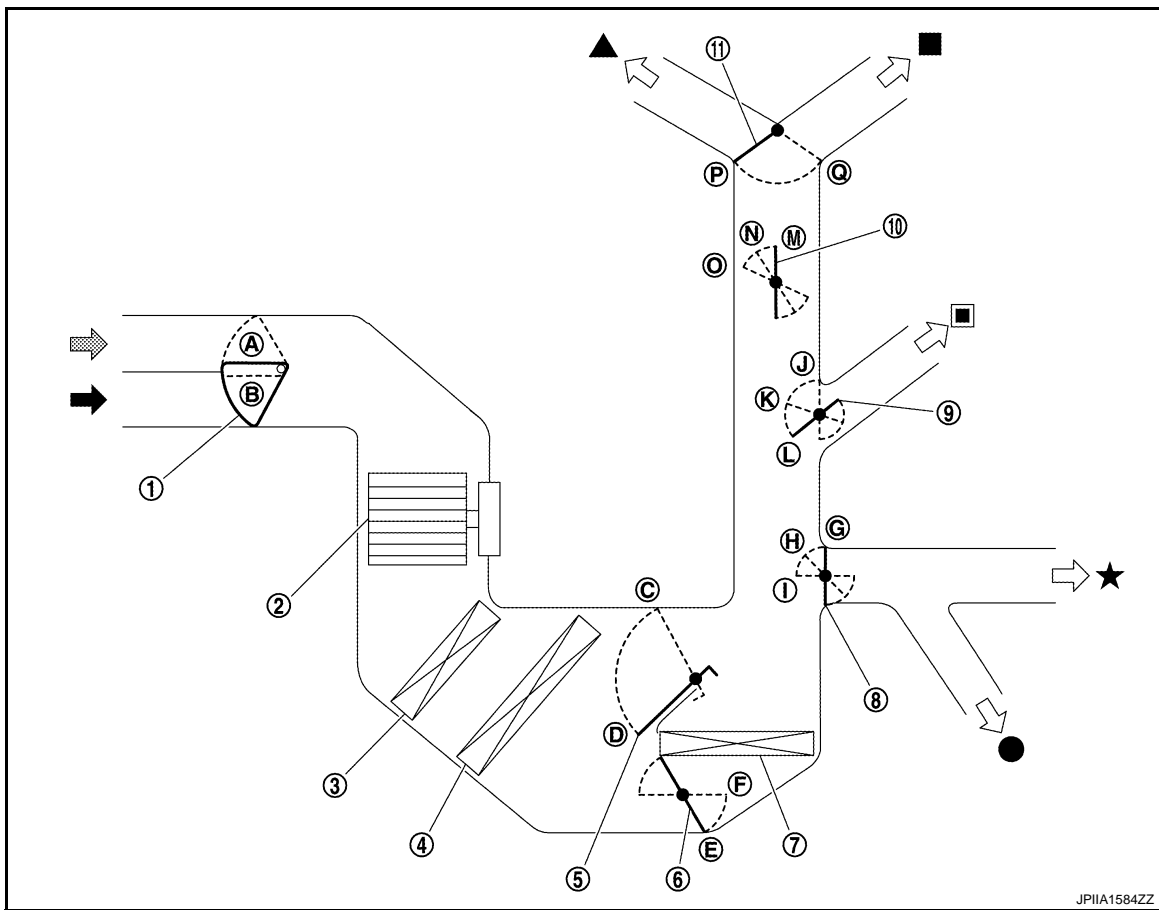

JPIIA1584ZZ

- |                        |  |                         |
|------------------------|--|-------------------------|
| 1. Intake door         | 2. Blower motor                          | 3. In-cabin microfilter |
| 4. Evaporator          | 5. Upper air mix door                    | 6. Lower air mix door   |
| 7. Heater core         | 8. Foot door                             | 9. Side ventilator door |
| 10. Sub defroster door | 11. Center ventilator and defroster door |                         |
| ◀ Fresh air intake     | ◀ Recirculation air                      | ▲ Defroster             |
| ■ Center ventilator    | ■ Side ventilator                        | ★ Foot                  |
| ● Rear foot            |  |                         |

		Door position						
		Center ventilator and defroster door	Sub defroster door	Side ventilator door	Foot door	Intake door	Upper air mix door	Lower air mix door
AUTO switch	AUTO	AUTO						

# AUTOMATIC AIR CONDITIONING SYSTEM

< SYSTEM DESCRIPTION >

[AUTOMATIC AIR CONDITIONING]

Switch position		Door position						
		Center ventilator and defroster door	Sub defroster door	Side ventilator door	Foot door	Intake door	Upper air mix door	Lower air mix door
MODE switch		P	M	L	G	—	—	—
				K	H			
		Q	O	J	I			
			N					
DEF switch			M		G			
REC switch*						A		
FRE switch*						B		
Temperature control switch	Full cold 18°C (60°F)	—	—	—	—	—	D	E
	19°C – 31°C (61°F – 89°F)						AUTO	AUTO
	Full hot 32°C (90°F)						C	F
OFF switch	OFF	Q	O	J	G	B	—	—

\*: Inlet status is displayed by indicator during activating automatic control

## AIR DISTRIBUTION

Discharge air flow				
Mode position indication	Air outlet/distribution			
	Ventilator	Front foot	Rear foot	Defroster
	100%	—	—	—
	57%	29%	14%	—
	19%	44%	19%	18%
	17%	40%	17%	26%
	18%	—	—	82%

A  
B  
C  
D  
E  
F  
G  
H  
J  
K  
L  
M  
N  
O  
P

HAC

# AUTOMATIC AIR CONDITIONING SYSTEM

< SYSTEM DESCRIPTION >

[AUTOMATIC AIR CONDITIONING]

## Component Parts Location

INFOID:000000005490035

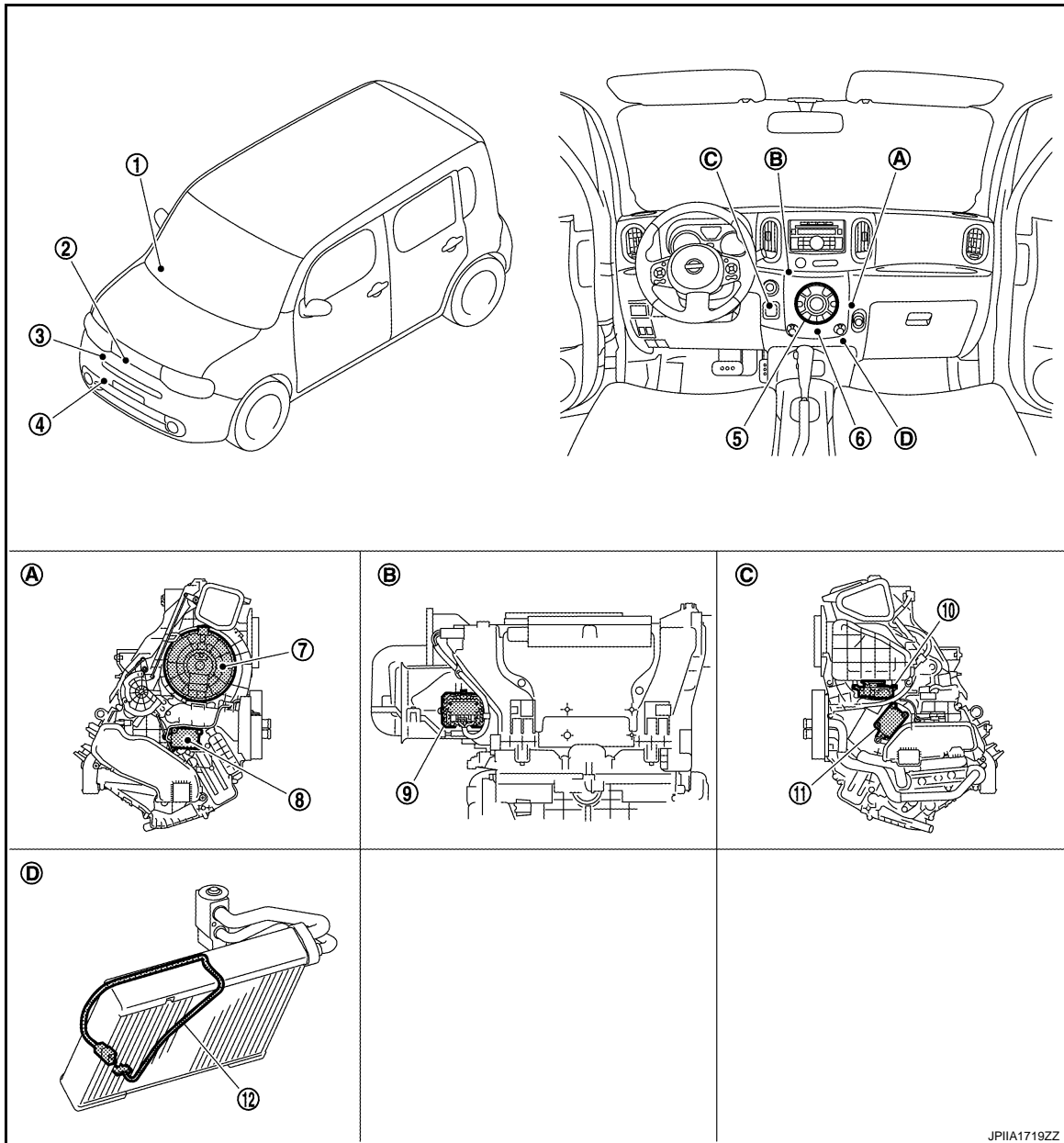

JPIIA1719ZZ

- |   |   |  |
|---|---|--|
| 1. Sunload sensor                                 | 2. Ambient sensor                           | 3. Magnet clutch                             |
| 4. Refrigerant pressure sensor                    | 5. A/C control (A/C auto amp.)              | 6. In-vehicle sensor                         |
| 7. Blower motor                                   | 8. Mode door motor                          | 9. Power transistor                          |
| 10. Intake door motor                             | 11. Air mix door motor                      | 12. Intake sensor                            |
| A. Located in the right side of A/C unit assembly | B. Located in the back of A/C unit assembly | C. Located in left side of A/C unit assembly |
| D. Located on the evaporator                      |   |  |

## Component Description

INFOID:000000005490036

Component	Description
Sunload sensor	<a href="#">HAC-43. "Description"</a>
Ambient sensor	<a href="#">HAC-35. "Description"</a>



# AUTOMATIC AIR CONDITIONING SYSTEM

< SYSTEM DESCRIPTION >

[AUTOMATIC AIR CONDITIONING]

Component	Description
Magnet clutch	<a href="#">HAC-61. "Description"</a>
Refrigerant pressure sensor	<a href="#">EC-415. "Description"</a>
A/C control (A/C auto amp.)	<a href="#">HAC-70. "Description"</a>
In-vehicle sensor	<a href="#">HAC-38. "Description"</a>
Blower motor	<a href="#">HAC-56. "Description"</a>
Air mix door motor	<a href="#">HAC-46. "Description"</a>
Power transistor	<a href="#">HAC-56. "Description"</a>
Intake sensor	<a href="#">HAC-41. "Description"</a>
Mode door motor	<a href="#">HAC-49. "Description"</a>
Intake door motor	<a href="#">HAC-52. "Description"</a>

A  
B  
C  
D  
E  
F  
G  
H  
J  
K  
L  
M  
N  
O  
P

HAC

# DIAGNOSIS SYSTEM (A/C AUTO AMP.)

< SYSTEM DESCRIPTION >

[AUTOMATIC AIR CONDITIONING]

## DIAGNOSIS SYSTEM (A/C AUTO AMP.)

### Diagnosis Description

INFOID:000000005490037

#### ON BOARD SELF-DIAGNOSIS SYSTEM

On board self-diagnosis system is built into A/C auto amp. to quickly locate the case of malfunctions. The self-diagnosis system diagnoses sensor, door motor, blower motor, etc. and also can make the setting of auxiliary mechanism.

Diagnosis item	Diagnosis content	Diagnosis part
STEP 1: Indicator check	Switch indicator and display indication are checked.	A/C control (A/C auto amp.)
STEP 2: Sensor diagnosis	The circuit diagnoses of each sensor and intake door motor are performed. A/C auto amp. indicates the result on the display.	<ul style="list-style-type: none"><li>• Ambient sensor</li><li>• In-vehicle sensor</li><li>• Intake sensor</li><li>• Sunload sensor</li><li>• Intake door motor (PBR)</li></ul>
STEP 3: Door motor diagnosis	The circuit diagnoses of mode door motor and air mix door motor are performed. A/C auto amp. indicates the result on the display.	<ul style="list-style-type: none"><li>• Mode door motor</li><li>• Air mix door motor</li></ul>
STEP 4: Operation check	Operational check of each part is performed.	<ul style="list-style-type: none"><li>• Mode door motor</li><li>• Intake door motor</li><li>• Air mix door motor</li><li>• Blower motor</li><li>• Compressor</li><li>• Condenser fan</li></ul>
STEP 5: Each sensor recognition temperature check	Each sensor recognition temperature is indicated on the display.	<ul style="list-style-type: none"><li>• Ambient sensor</li><li>• In-vehicle sensor</li><li>• Intake sensor</li></ul>
STEP 6: Temperature setting trimmer	Temperature setting trimmer is performed.	—
STEP 7: Inlet port memory function	Inlet port memory function is performed.	—

#### SELF-DIAGNOSIS PROCEDURE

##### Self-diagnosis Mode Entry

The self-diagnosis is started by pressing the OFF switch at 5 seconds or more within 10 seconds after starting engine.

##### NOTE:

If battery voltage drops below 12 V during diagnosis STEP-3, door motor speed becomes slower and as a result, the system may generate an error even when operation is normal. Start engine before performing this diagnosis to avoid this.

##### Changes of Step up and Step down

- The changes of STEP 1 – 5 can be performed by pressing the temperature control switch.
- The change of STEP 6 – 7 can be performed by pressing the fan control switch during the condition of STEP-5.

##### Self-diagnosis Cancellation

By AUTO switch is pressed or ignition switch is turned OFF, the self-diagnosis is canceled.

#### STEP-1: INDICATOR CHECK

##### Description

A/C switch indicator and A/C display indication are checked.

Normal: All switch indicator and display indication are turned ON.

Malfunction: Malfunctioning part indicator is not turned ON.

#### STEP-2: SENSOR DIAGNOSIS

# DIAGNOSIS SYSTEM (A/C AUTO AMP.)

[AUTOMATIC AIR CONDITIONING]

## < SYSTEM DESCRIPTION >

### Description

When STEP-2 is selected, "2" is indicated on the display for 3 seconds, in this period, sensor diagnosis is started.

Normal: "20" is displayed.

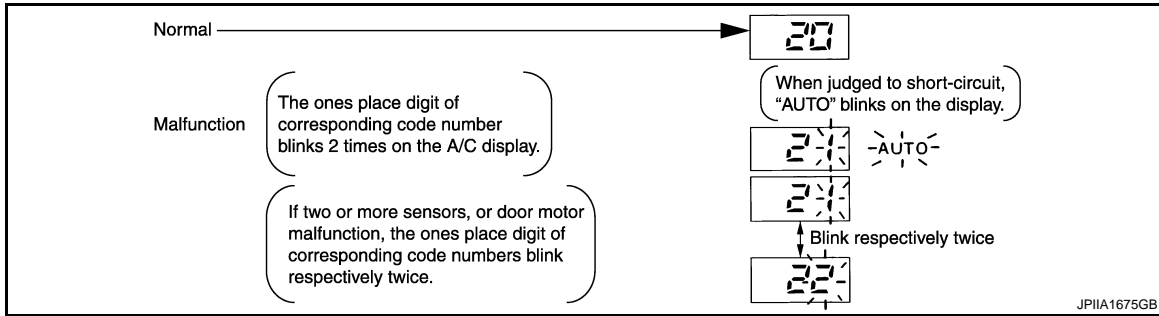

Malfunction: The ones place digit of corresponding code number blinks 2 times on the A/C display. When short-circuit error, "AUTO" blinks on the display.

### NOTE:

If two or more sensors, or door motor malfunction, the ones place digit of corresponding code numbers blink respectively twice.

### Diagnosis Result

Code No.	Corresponding sensor or door motor	Malfunctioning judgment condition		Reference
		Open	Short	
21 / AUTO 21	Ambient sensor	-42°C (-44°F) or less	100°C (212°F) or more	<a href="#">HAC-35. "Diagnosis Procedure"</a>
22 / AUTO 22	In-vehicle sensor	-42°C (-44°F) or less	100°C (212°F) or more	<a href="#">HAC-38. "Diagnosis Procedure"</a>
24 / AUTO 24	Intake sensor	-42°C (-44°F) or less	100°C (212°F) or more	<a href="#">HAC-41. "Diagnosis Procedure"</a>
25 / AUTO 25	Sunload sensor*	33 W/m <sup>2</sup> (28 kcal/m <sup>2</sup> .h)	1677 W/m <sup>2</sup> (1442 kcal/m <sup>2</sup> .h)	<a href="#">HAC-43. "Diagnosis Procedure"</a>
26 / AUTO 26	Intake door motor (PBR)	PBR angle 30% or less	PBR angle 50% or more	<a href="#">HAC-52. "Diagnosis Procedure"</a>

\*: Perform the self-diagnosis under sunshine. When performing indoors, aim a light (more than 60 W) at sunload sensor, otherwise code NO. 25 indicates despite that sunload sensor is functioning normally.

### NOTE:

- When ambient sensor has the malfunction of open-circuit, the sensor judges that ambient temperature is extremely cold, and controls the in vehicle temperature to warmly.
- When performing the diagnosis of intake door motor, the target angle of PBR is set at 40%.
- The error judgment status of intake door motor is not decided by open or short circuit, it is decided by the voltage value as follows:
  - Short: 2.5 V or more
  - Open: 1.5 V or less

## STEP-3: DOOR MOTOR DIAGNOSIS

### Description

When STEP-3 is selected, "3" is indicated on the display for 1 second, in this period, door motor diagnosis is started.

The check of door motor is performed by A/C auto amp. transmitting output signal to each door motor.

# DIAGNOSIS SYSTEM (A/C AUTO AMP.)

[AUTOMATIC AIR CONDITIONING]

< SYSTEM DESCRIPTION >

Normal: "30" is displayed.

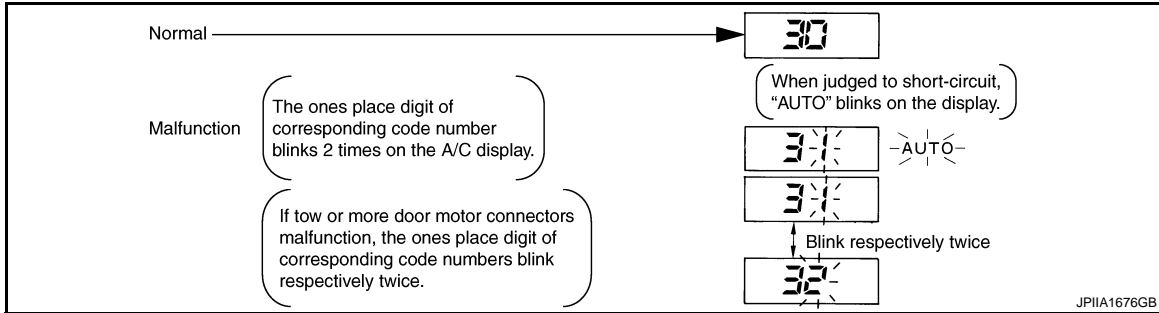

Malfunction: The ones place digit of corresponding code number blinks 2 times on the A/C display. When short-circuit error, "AUTO" blinks on the display.

**NOTE:**

If two or more door motor connectors malfunction, the ones place digit of corresponding code numbers blink respectively twice.

**NOTE:**

When the malfunctioning condition as following figure, "31" is displayed.

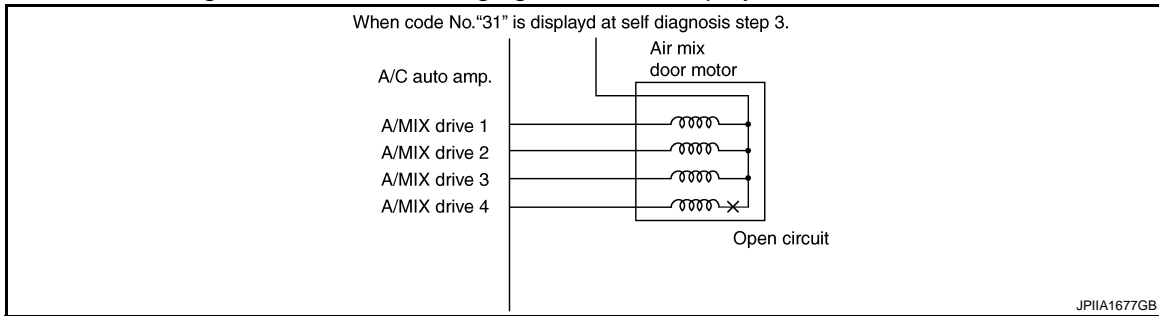

Diagnosis Result

Code No.	Corresponding door motor	Malfunctioning judgment condition	Reference
31 / AUTO 31	Air mix door motor	Short or open circuit of air mix door drive signal terminal 4	<a href="#">HAC-46, "Diagnosis Procedure"</a>
32 / AUTO 32		Short or open circuit of air mix door drive signal terminal 1	
33 / AUTO 33		Short or open circuit of air mix door drive signal terminal 2	
34 / AUTO 34		Short or open circuit of air mix door drive signal terminal 3	
35 / AUTO 35	Mode door motor	Short or open circuit of mode door drive signal terminal 4	<a href="#">HAC-49, "Diagnosis Procedure"</a>
36 / AUTO 36		Short or open circuit of mode door drive signal terminal 1	
37 / AUTO 37		Short or open circuit of mode door drive signal terminal 2	
38 / AUTO 38		Short or open circuit of mode door drive signal terminal 3	

**NOTE:**

- If all four terminals of each door motor show an open circuit, there is probably a disconnected connector or an open circuit in door motor drive power supply harness.
- If a short circuit occurs in harness between terminals for each door motor drive signal, although it cannot be detected by self-diagnosis, door motor will vibrate when it operates.

Door Motor Starting Position Reset

- Pressing DEF switch during STEP-3 will send a reset signal to air mix door and mode door motor to reset them to starting position.

# DIAGNOSIS SYSTEM (A/C AUTO AMP.)

## [AUTOMATIC AIR CONDITIONING]

### < SYSTEM DESCRIPTION >

- During reset operation, DEF switch indicator and “30” blink for approximately 9 seconds.

### STEP-4: OPERATION CHECK

#### Description

When STEP-4 is selected, each part operation is started with indicating “4” on the display.  
Each time DEF switch is pressed, the display will change to 41 → 42 → 43 → 44 → 45 → 46 → 41.

#### Operation Contents

Checks must be visually, by listening the sound or by touching air outlets with hand, etc. for improper operation.

Code No.	Mode door position	Intake door position	Air mix door position	Magnet clutch	Blower fan motor (voltage)	Condenser fan ON signal
41	VENT	REC	Full cold	ON	5 V	ON
42	B/L	REC	Full cold	ON	10.5 V	ON
43	B/L	20% FRE	Medium (50%)	ON	8.5 V	ON
44	FOOT	80% FRE	Medium (50%)	OFF	8.5 V	OFF
45	D/F	FRE	Full hot	OFF	8.5 V	OFF
46	DEF	FRE	Full hot	ON	Battery voltage	ON

### STEP-5: EACH SENSOR RECOGNITION CHECK

#### Description

When STEP-5 is selected, “5” is indicated on the display.  
Each time DEF switch is pressed, each sensor recognition temperature is changed in order of the following:  
5 → Ambient temperature → In-vehicle temperature → Intake temperature → 5.

#### NOTE:

Each sensor recognition temperature is not displayed in less than  $-30^{\circ}\text{C}$  ( $-22^{\circ}\text{F}$ ) or more than  $55^{\circ}\text{C}$  ( $131^{\circ}\text{F}$ ).

### STEP-6: TEMPERATURE SETTING TRIMMER

#### Description

The trimmer compensates for differences in range of  $\pm 3^{\circ}\text{C}$  ( $\pm 6^{\circ}\text{F}$ ) between temperature setting (displayed digitally) and temperature felt by customer.

#### Setting Procedure

Refer to [HAC-10. "Temperature Setting Trimmer"](#).

### STEP-7: INLET PORT MEMORY FUNCTION

#### Description

- Inlet port setting can be memorized when ignition switch is turned OFF.
- Inlet port setting can be selected from FRE (fresh air intake), REC (recirculation), or “Do not perform the memory” when ignition switch is turned ON.

#### Setting Procedure

Refer to [HAC-11. "Inlet Port Memory Function"](#).

# DIAGNOSIS SYSTEM (BCM) (WITH INTELLIGENT KEY SYSTEM)

< SYSTEM DESCRIPTION >

[AUTOMATIC AIR CONDITIONING]

## DIAGNOSIS SYSTEM (BCM) (WITH INTELLIGENT KEY SYSTEM)

### COMMON ITEM

COMMON ITEM : CONSULT-III Function (BCM - COMMON ITEM)

INFOID:000000005490038

### APPLICATION ITEM

CONSULT-III performs the following functions via CAN communication with BCM.

Diagnosis mode	Function Description
Work Support	Changes the setting for each system function.
Self Diagnostic Result	Displays the diagnosis results judged by BCM.
CAN Diag Support Monitor	Monitors the reception status of CAN communication viewed from BCM. Refer to CONSULT-III operation manual.
Data Monitor	The BCM input/output signals are displayed.
Active Test	The signals used to activate each device are forcibly supplied from BCM.
Ecu Identification	The BCM part number is displayed.
Configuration	<ul style="list-style-type: none"> <li>Read and save the vehicle specification.</li> <li>Write the vehicle specification when replacing BCM.</li> </ul>

### SYSTEM APPLICATION

BCM can perform the following functions for each system.

#### NOTE:

It can perform the diagnosis modes except the following for all sub system selection items.

×: Applicable item

System	Sub system selection item	Diagnosis mode		
		Work Support	Data Monitor	Active Test
Door lock	DOOR LOCK	×	×	×
Rear window defogger	REAR DEFOGGER		×	×
Warning chime	BUZZER		×	×
Interior room lamp timer	INT LAMP	×	×	×
Remote keyless entry system	MULTI REMOTE ENT*1	×	×	×
Exterior lamp	HEAD LAMP	×	×	×
Wiper and washer	WIPER	×*2	×	×
Turn signal and hazard warning lamps	FLASHER	×	×	×
—	AIR CONDITONER*3			
<ul style="list-style-type: none"> <li>Intelligent Key system</li> <li>Engine start system</li> </ul>	INTELLIGENT KEY	×	×	×
Combination switch	COMB SW		×	
Body control system	BCM	×		
NVIS - NATS	IMMU		×	×
Interior room lamp battery saver	BATTERY SAVER	×	×	×
Back door opener system	TRUNK		×	×
Vehicle security system	THEFT ALM	×	×	×
RAP system	RETAINED PWR		×	
Signal buffer system	SIGNAL BUFFER		×	×
TPMS	TPMS (AIR PRESSURE MONITOR)	×	×	×

#### NOTE:

- \*1: At models with Intelligent Key system this item is displayed, but is not used.
- \*2: At models with rain sensor this mode is displayed, but is not used.

# DIAGNOSIS SYSTEM (BCM) (WITH INTELLIGENT KEY SYSTEM)

< SYSTEM DESCRIPTION >

[AUTOMATIC AIR CONDITIONING]

- \*3: This item is displayed, but is not used.

## FREEZE FRAME DATA (FFD)

The BCM records the following vehicle condition at the time a particular DTC is detected, and displays on CONSULT-III.

CONSULT screen item	Indication/Unit	Description	
Vehicle Speed	km/h	Vehicle speed of the moment a particular DTC is detected	
Odo/Trip Meter	km	Total mileage (Odometer value) of the moment a particular DTC is detected	
Vehicle Condition	SLEEP>LOCK	Power position status of the moment a particular DTC is detected	While turning BCM status from low power consumption mode to normal mode (Power supply position is "LOCK")
	SLEEP>OFF		While turning BCM status from low power consumption mode to normal mode (Power supply position is "OFF".)
	LOCK>ACC		While turning power supply position from "LOCK" to "ACC"
	ACC>ON		While turning power supply position from "ACC" to "IGN"
	RUN>ACC		While turning power supply position from "RUN" to "ACC" (Vehicle is stopping and selector lever is except P position.)
	CRANK>RUN		While turning power supply position from "CRANKING" to "RUN" (From cranking up the engine to run it)
	RUN>URGENT		While turning power supply position from "RUN" to "ACC" (Emergency stop operation)
	ACC>OFF		While turning power supply position from "ACC" to "OFF"
	OFF>LOCK		While turning power supply position from "OFF" to "LOCK"
	OFF>ACC		While turning power supply position from "OFF" to "ACC"
	ON>CRANK		While turning power supply position from "IGN" to "CRANKING"
	OFF>SLEEP		While turning BCM status from normal mode (Power supply position is "OFF".) to low power consumption mode
	LOCK>SLEEP		While turning BCM status from normal mode (Power supply position is "LOCK".) to low power consumption mode
	LOCK		Power supply position is "LOCK" (Ignition switch OFF with steering is locked.)
	OFF		Power supply position is "OFF" (Ignition switch OFF with steering is unlocked.)
	ACC		Power supply position is "ACC" (Ignition switch ACC)
	ON		Power supply position is "IGN" (Ignition switch ON with engine stopped)
ENGINE RUN	Power supply position is "RUN" (Ignition switch ON with engine running)		
CRANKING	Power supply position is "CRANKING" (At engine cranking)		
IGN Counter	0 - 39	The number of times that ignition switch is turned ON after DTC is detected <ul style="list-style-type: none"> <li>The number is 0 when a malfunction is detected now.</li> <li>The number increases like 1 → 2 → 3...38 → 39 after returning to the normal condition whenever ignition switch OFF → ON.</li> <li>The number is fixed to 39 until the self-diagnosis results are erased if it is over 39.</li> </ul>	

## AIR CONDITIONER

### AIR CONDITIONER : CONSULT-III Function (BCM - AUTO AIR CONDITIONER)

INFOID:000000005490039

## DATA MONITOR

Display Item List

# DIAGNOSIS SYSTEM (BCM) (WITH INTELLIGENT KEY SYSTEM)

< SYSTEM DESCRIPTION >

[AUTOMATIC AIR CONDITIONING]

Monitor Item [Unit]	Contents
FAN ON SIG [On/Off]	Displays the blower fan status as judged from the A/C auto amp.
AIR COND SW [On/Off]	Displays [COMP (On)/COMP (Off)] status as judged from the A/C auto amp.



# DIAGNOSIS SYSTEM (BCM) (WITHOUT INTELLIGENT KEY SYSTEM)

< SYSTEM DESCRIPTION >

[AUTOMATIC AIR CONDITIONING]

## DIAGNOSIS SYSTEM (BCM) (WITHOUT INTELLIGENT KEY SYSTEM) COMMON ITEM

COMMON ITEM : CONSULT-III Function (BCM - COMMON ITEM)

INFOID:000000005490040

### APPLICATION ITEM

CONSULT-III can display each diagnostic item using the diagnostic test modes shown following.

Diagnosis mode	Function description
ECU Identification	BCM part number is displayed.
Self-Diagnostic Result	Displays the diagnosis results judged by BCM. Refer to <a href="#">BCS-142, "DTC Index"</a> .
Data Monitor	BCM input/output signals are displayed.
Active Test	The signals used to activate each device are forcibly supplied from BCM.
Work Support	Changes the setting for each system function.
Configuration	<ul style="list-style-type: none"> <li>Read and save the vehicle specification.</li> <li>Write the vehicle specification when replacing BCM.</li> </ul>
CAN Diag Support Monitor	Monitors the reception status of CAN communication viewed from BCM.

### SYSTEM APPLICATION

BCM can perform the following functions for each system.

#### NOTE:

It can perform the diagnosis modes except the following for all sub system selection items.

×: Applicable item

System	CONSULT-III sub system selection item	Diagnosis mode		
		WORK SUPPORT	DATA MONITOR	ACTIVE TEST
Door lock	DOOR LOCK	×	×	×
Rear window defogger	REAR DEFOGGER		×	×
Warning chime	BUZZER		×	×
Interior room lamp control	INT LAMP	×	×	×
Remote keyless entry system	MULTI REMOTE ENT	×	×	×
Exterior lamp	HEAD LAMP	×	×	×
Wiper and washer	WIPER	×	×	×
Turn signal and hazard warning lamps	FLASHER		×	×
Air conditioner	AIR CONDITONER		×	
—	INTELLIGENT KEY*			
Combination switch	COMB SW		×	
—	BCM	×		
Immobilizer	IMMU		×	×
Interior room lamp battery saver	BATTERY SAVER	×	×	×
Back door open	TRUNK		×	×
Vehicle security system	THEFT ALM	×	×	×
RAP system	RETAINED PWR	×	×	×
Signal buffer system	SIGNAL BUFFER		×	×
—	FUEL LID*			
—	TPMS*			
Panic alarm system	PANIC ALARM			×

\*: This item is displayed, but is not function.

## AIR CONDITIONER

# DIAGNOSIS SYSTEM (BCM) (WITHOUT INTELLIGENT KEY SYSTEM)

< SYSTEM DESCRIPTION >

[AUTOMATIC AIR CONDITIONING]

## AIR CONDITIONER : CONSULT-III Function (BCM - AUTO AIR CONDITIONER)

INFOID:000000005490041

### DATA MONITOR

#### Display Item List

Monitor Item [Unit]	Contents
IGN SW [On/Off]	Displays ignition switch position status as judged from ignition switch signal.
FAN ON SIG [On/Off]	Displays the blower fan status as judged from the A/C auto amp.
AIR COND SW [On/Off]	Displays [COMP (On)/COMP (Off)] status as judged from the A/C auto amp.

DTC/CIRCUIT DIAGNOSIS

AMBIENT SENSOR

Description

INFOID:000000005490042

COMPONENT DESCRIPTION

- The ambient sensor (1) is installed on the middle of radiator upper support.
- The ambient sensor converts the ambient temperature detected with thermistor into the voltage, and the A/C auto amp. inputs this voltage.

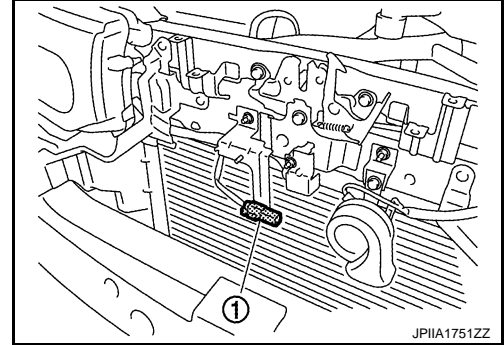

AMBIENT TEMPERATURE CORRECTION

- The A/C auto amp. inputs the temperature detected with the ambient sensor as the ambient temperature.
- Perform the correction of the temperature detected with the ambient sensor for air conditioner control and for ambient temperature display.
- Since the engine heat influences on the ambient sensor during idling condition, the A/C auto amp. retards the ambient temperature indication of the combination meter to avoid the effect of steep temperature change.
- Select and use the initial value of ambient temperature data depending on the coolant temperature when turning the ignition switch from OFF to ON. Use the detection temperature of the ambient sensor at low coolant temperature [less than approximately 56°C (133°F)]. Use the memory data (before the ignition switch is OFF) when the engine is warming up [approximately 56°C (133°F) or more].
- Do not perform the correction of the ambient temperature when the detection temperature of the ambient temperature is less than approximately -20°C (-4°F).

SET TEMPERATURE CORRECTION

The A/C auto amp. performs the correction to the target temperature set by the temperature control switch so as to match the temperature felt by the passengers depending on the ambient temperature detected with the ambient sensor and controls it so that the interior air temperature is always the most suitable.

Diagnosis Procedure

INFOID:000000005490043

1. CHECK AMBIENT SENSOR POWER SUPPLY CIRCUIT

1. Turn the ignition switch OFF.
2. Disconnect the ambient sensor connector.
3. Turn the ignition switch ON.
4. Check voltage between ambient sensor harness connector and the ground.

(+)		(-)	Voltage (Approx.)
Connector	Terminal	—	
E53	1	Ground	5 V

Is the inspection result normal?

- YES >> GO TO 2.
- NO >> GO TO 4.

2. CHECK AMBIENT SENSOR GROUND CIRCUIT CONTINUITY

1. Turn the ignition switch OFF.
2. Disconnect the A/C auto amp. connector.
3. Check continuity between ambient sensor harness connector and A/C auto amp harness connector.

A  
B  
C  
D  
E  
F  
G  
H  
HAC  
J  
K  
L  
M  
N  
O  
P

# AMBIENT SENSOR

< DTC/CIRCUIT DIAGNOSIS >

[AUTOMATIC AIR CONDITIONING]

Ambient sensor		A/C auto amp.		Continuity
Connector	Terminal	Connector	Terminal	
E53	2	M50	6	Existed

Is the inspection result normal?

YES >> GO TO 3.

NO >> Repair the harnesses or connectors.

## 3.CHECK AMBIENT SENSOR

Check the ambient sensor components. Refer to [HAC-36, "Component Inspection"](#).

Is the inspection result normal?

YES >> INSPECTION END

NO >> Replace the ambient sensor.

## 4.CHECK AMBIENT SENSOR OPEN CIRCUIT

1. Turn the ignition switch OFF.
2. Disconnect the A/C auto amp. connector.
3. Check continuity between ambient sensor harness connector and A/C auto amp. harness connector.

Ambient sensor		A/C auto amp.		Continuity
Connector	Terminal	Connector	Terminal	
E53	1	M51	22	Existed

Is the inspection result normal?

YES >> GO TO 5.

NO >> Repair the harnesses or connectors.

## 5.CHECK AMBIENT SENSOR SHORT CIRCUIT

Check continuity between ambient sensor harness connector and the ground.

Ambient sensor		—	Continuity
Connector	Terminal		
E53	1	Ground	Not existed

Is the inspection result normal?

YES >> Replace the A/C auto amp.

NO >> Repair the harnesses or connectors.

## Component Inspection

INFOID:000000005490044

### 1.CHECK AMBIENT SENSOR

1. Turn the ignition switch OFF.
2. Remove the ambient sensor. Refer to [HAC-144, "Exploded View"](#).
3. Check the resistance between the ambient sensor terminals. Refer to the applicable table for the normal value.

# AMBIENT SENSOR

< DTC/CIRCUIT DIAGNOSIS >

[AUTOMATIC AIR CONDITIONING]

Terminal		Condition	Resistance: kΩ
		Temperature: °C (°F)	
1	2	-15 (5)	12.73
		-10 (14)	9.92
		-5 (23)	7.80
		0 (32)	6.19
		5 (41)	4.95
		10 (50)	3.99
		15 (59)	3.24
		20 (68)	2.65
		25 (77)	2.19
		30 (86)	1.81
		35 (95)	1.51
		40 (104)	1.27
		45 (113)	1.07

Is the inspection result normal?

YES >> INSPECTION END

NO >> Replace the ambient sensor.

A  
B  
C  
D  
E  
F  
G  
H  
J  
K  
L  
M  
N  
O  
P

HAC

## IN-VEHICLE SENSOR

### Description

INFOID:000000005490045

#### COMPONENT DESCRIPTION

- The in-vehicle sensor (1) is installed to the finisher.
- The in-vehicle sensor converts the interior air temperature of the passenger room sucked by the aspirator detected with the thermistor into the voltage, and the A/C auto amp. inputs this voltage.

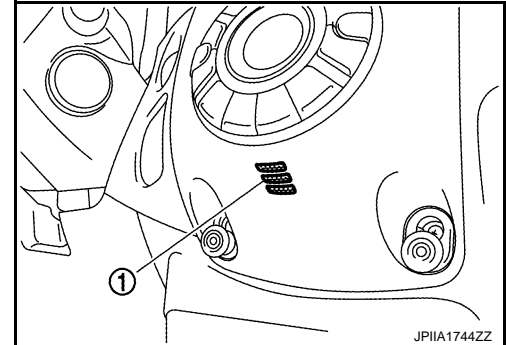

#### ASPIRATOR

The aspirator (1) generates the vacuum by the air blown from the A/C unit assembly and draws the air of the passenger room to the in-vehicle sensor area via the aspirator duct.

← : Vehicle front

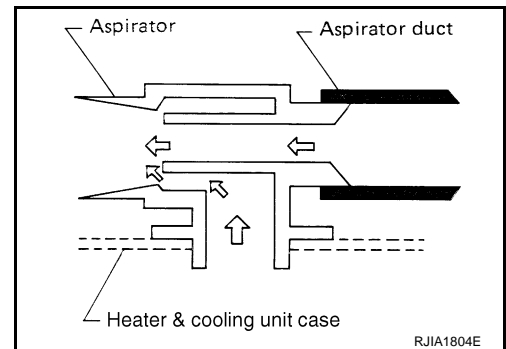
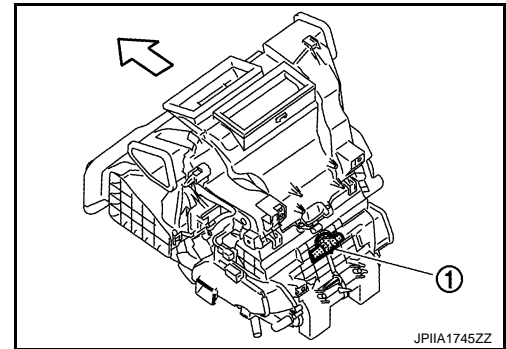

#### INTERIOR AIR TEMPERATURE CORRECTION

- The A/C auto amp. inputs the temperature detected with the in-vehicle sensor as the interior air temperature.
- Perform the correction of the temperature detected with the in-vehicle sensor for each air conditioner control.

### Diagnosis Procedure

INFOID:000000005490046

#### 1. CHECK IN-VEHICLE SENSOR POWER SUPPLY CIRCUIT

1. Turn the ignition switch OFF.
2. Disconnect the in-vehicle sensor connector.
3. Turn the ignition switch ON.
4. Check voltage between in-vehicle sensor harness connector and the ground.

(+)		(-)	Voltage (Approx.)
In-vehicle sensor		—	
Connector	Terminal	Ground	
M41	1	Ground	5 V

# IN-VEHICLE SENSOR

[AUTOMATIC AIR CONDITIONING]

< DTC/CIRCUIT DIAGNOSIS >

Is the inspection result normal?

- YES >> GO TO 2.
- NO >> GO TO 4.

## 2.CHECK IN-VEHICLE SENSOR GROUND CIRCUIT CONTINUITY

1. Turn the ignition switch OFF.
2. Disconnect the A/C auto amp. connector.
3. Check continuity between in-vehicle sensor harness connector and A/C auto amp. harness connector.

In-vehicle sensor		A/C auto amp.		Continuity
Connector	Terminal	Connector	Terminal	
M41	2	M50	6	Existed

Is the inspection result normal?

- YES >> GO TO 3.
- NO >> Repair the harnesses or connectors.

## 3.CHECK IN-VEHICLE SENSOR

Check the in-vehicle sensor components. Refer to [HAC-39, "Component Inspection"](#).

Is the inspection result normal?

- YES >> INSPECTION END
- NO >> Replace the in-vehicle sensor.

## 4.CHECK IN-VEHICLE SENSOR OPEN CIRCUIT

1. Turn the ignition switch OFF.
2. Disconnect the A/C auto amp. connector.
3. Check continuity between in-vehicle sensor harness connector and A/C auto amp. harness connector.

In-vehicle sensor		A/C auto amp.		Continuity
Connector	Terminal	Connector	Terminal	
M41	1	M51	24	Existed

Is the inspection result normal?

- YES >> GO TO 5.
- NO >> Repair the harnesses or connectors.

## 5.CHECK IN-VEHICLE SENSOR SHORT CIRCUIT

Check continuity between in-vehicle sensor harness connector and the ground.

In-vehicle sensor		—	Continuity
Connector	Terminal		
M41	1	Ground	Not existed

Is the inspection result normal?

- YES >> Replace the A/C auto amp.
- NO >> Repair the harnesses or connectors.

## Component Inspection

INFOID:000000005490047

## 1.CHECK IN-VEHICLE SENSOR

1. Turn the ignition switch OFF.
2. Remove the in-vehicle sensor. Refer to [HAC-145, "Exploded View"](#).
3. Check the resistance between the in-vehicle sensor terminals. Refer to the applicable table for the normal value.

# IN-VEHICLE SENSOR

< DTC/CIRCUIT DIAGNOSIS >

[AUTOMATIC AIR CONDITIONING]

Terminal		Condition	Resistance: kΩ
		Temperature: °C (°F)	
1	2	-15 (5)	12.73
		-10 (14)	9.92
		-5 (23)	7.80
		0 (32)	6.19
		5 (41)	4.95
		10 (50)	3.99
		15 (59)	3.24
		20 (68)	2.65
		25 (77)	2.19
		30 (86)	1.81
		35 (95)	1.51
		40 (104)	1.27
		45 (113)	1.07

Is the inspection result normal?

YES >> INSPECTION END

NO >> Replace the in-vehicle sensor.



# INTAKE SENSOR

< DTC/CIRCUIT DIAGNOSIS >

[AUTOMATIC AIR CONDITIONING]

## INTAKE SENSOR

### Description

INFOID:000000005490048

#### COMPONENT DESCRIPTION

- Intake sensor (1) is located on the evaporator.
- The intake sensor converts the evaporator surface temperature detected with thermistor into the voltage, and the A/C auto amp. inputs this voltage.

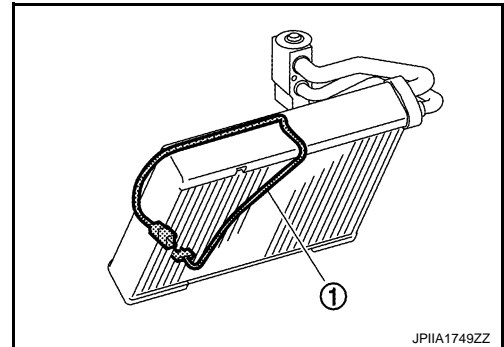

#### INTAKE TEMPERATURE CORRECTION

- The A/C auto amp. inputs the temperature detected with the intake sensor as the evaporator surface temperature.
- Perform the correction of the temperature detected with the intake sensor for air conditioner control.
- The A/C auto amp. performs the correction so that the recognition intake temperature changes depending on the difference between the detected intake temperature and the recognition intake temperature. If the difference is large, the changing is early. The changing becomes slow as the difference becomes small.

### Diagnosis Procedure

INFOID:000000005490049

#### 1. CHECK INTAKE SENSOR POWER SUPPLY CIRCUIT

1. Turn the ignition switch OFF.
2. Disconnect the intake sensor connector.
3. Turn the ignition switch ON.
4. Check voltage between intake sensor harness connector and the ground.

(+)		(-)	Voltage (Approx.)
Intake sensor		—	
Connector	Terminal		
M42	1	Ground	5 V

Is the inspection result normal?

YES >> GO TO 2.

NO >> GO TO 4.

#### 2. CHECK INTAKE SENSOR GROUND CIRCUIT CONTINUITY

1. Turn the ignition switch OFF.
2. Disconnect the A/C auto amp. connector.
3. Check continuity between intake sensor harness connector and A/C auto amp. harness connector.

Intake sensor		A/C auto amp.		Continuity
Connector	Terminal	Connector	Terminal	
M42	2	M50	6	Existed

Is the inspection result normal?

YES >> GO TO 3.

NO >> Repair the harnesses or connectors.

#### 3. CHECK INTAKE SENSOR

Check the intake sensor components. Refer to [HAC-42. "Component Inspection"](#).

Is the inspection result normal?

A  
B  
C  
D  
E  
F  
G  
H  
HAC  
J  
K  
L  
M  
N  
O  
P

# INTAKE SENSOR

[AUTOMATIC AIR CONDITIONING]

< DTC/CIRCUIT DIAGNOSIS >

- YES >> INSPECTION END
- NO >> Replace the intake sensor.

## 4.CHECK INTAKE SENSOR OPEN CIRCUIT

1. Turn the ignition switch OFF.
2. Disconnect the A/C auto amp. connector.
3. Check continuity between intake sensor harness connector and A/C auto amp. harness connector.

Intake sensor		A/C auto amp.		Continuity
Connector	Terminal	Connector	Terminal	
M42	1	M51	23	Existed

Is the inspection result normal?

- YES >> GO TO 5.
- NO >> Repair the harnesses or connectors.

## 5.CHECK INTAKE SENSOR SHORT CIRCUIT

Check continuity between intake sensor harness connector and the ground.

Intake sensor		—	Continuity
Connector	Terminal		
M42	1	Ground	Not existed.

Is the inspection result normal?

- YES >> Replace the A/C auto amp.
- NO >> Repair the harnesses or connectors.

## Component Inspection

INFOID:000000005490050

## 1.CHECK INTAKE SENSOR

1. Turn the ignition switch OFF.
2. Disconnect the intake sensor connector.
3. Check the resistance between the intake sensor terminals. Refer to the applicable table for the normal value.

Terminal	Condition	Resistance: kΩ	
			Temperature: °C (°F)
1	2	-15 (5)	12.34
		-10 (14)	9.62
		-5 (23)	7.56
		0 (32)	6.00
		5 (41)	4.80
		10 (50)	3.87
		15 (59)	3.15
		20 (68)	2.57
		25 (77)	2.12
		30 (86)	1.76
		35 (95)	1.47
		40 (104)	1.23
		45 (113)	1.04

Is the inspection result normal?

- YES >> INSPECTION END
- NO >> Replace the intake sensor.

# SUNLOAD SENSOR

< DTC/CIRCUIT DIAGNOSIS >

[AUTOMATIC AIR CONDITIONING]

## SUNLOAD SENSOR

### Description

INFOID:000000005490051

#### COMPONENT DESCRIPTION

- The sunload sensor (1) is installed to the right side of instrument panel assembly.
- The sunload sensor converts the sunload amount (illuminance) into the current value with the photodiode. The A/C auto amp. calculates this current value to the voltage and inputs it.

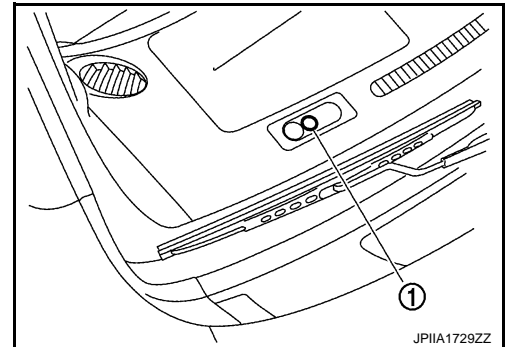

#### SUNLOAD AMOUNT CORRECTION

- The A/C auto amp. inputs the sunload amount detected with the sunload sensor.
- Perform the correction of the sunload amount detected with the sunload sensor for each air conditioner control.
- When the sunload amount suddenly changes, for example when entering a tunnel, perform the correction so that the recognition sunload amount of the A/C auto amp. changes slowly.

### Diagnosis Procedure

INFOID:000000005490052

#### 1.CHECK SUNLOAD SENSOR POWER SUPPLY CIRCUIT

1. Turn the ignition switch OFF.
2. Disconnect the sunload sensor connector.
3. Turn the ignition switch ON.
4. Check voltage between sunload sensor harness connector and the ground.

(+)		(-)	Voltage (Approx.)
Sunload sensor		—	
Connector	Terminal		
M74	1	Ground	5 V

Is the inspection result normal?

- YES >> GO TO 2.  
NO >> GO TO 4.

#### 2.CHECK SUNLOAD SENSOR GROUND CIRCUIT CONTINUITY

1. Turn the ignition switch OFF.
2. Disconnect the A/C auto amp. connector.
3. Check continuity between sunload sensor harness connector and A/C auto amp. harness connector.

Sunload sensor		A/C auto amp.		Continuity
Connector	Terminal	Connector	Terminal	
M74	2	M50	6	Existed

Is the inspection result normal?

- YES >> GO TO 3.  
NO >> Repair the harnesses or connectors.

#### 3.CHECK SUNLOAD SENSOR

1. Connect the sunload sensor connector.
2. Connect the A/C auto amp. connector.
3. Check the sunload sensor components. Refer to [HAC-44. "Component Inspection"](#).

A  
B  
C  
D  
E  
F  
G  
H  
HAC  
J  
K  
L  
M  
N  
O  
P

# SUNLOAD SENSOR

[AUTOMATIC AIR CONDITIONING]

< DTC/CIRCUIT DIAGNOSIS >

Is the inspection result normal?

- YES >> INSPECTION END
- NO >> Replace the sunload sensor.

## 4.CHECK SUNLOAD SENSOR OPEN CIRCUIT

1. Turn the ignition switch OFF.
2. Disconnect the A/C auto amp. connector.
3. Check continuity between sunload sensor harness connector and A/C auto amp. harness connector.

Sunload sensor		A/C auto amp.		Continuity
Connector	Terminal	Connector	Terminal	
M74	1	M51	25	Existed

Is the inspection result normal?

- YES >> GO TO 5.
- NO >> Repair the harnesses or connectors.

## 5.CHECK SUNLOAD SENSOR SHORT CIRCUIT

Check continuity between sunload sensor harness connector and the ground.

Sunload sensor		—	Continuity
Connector	Terminal		
M74	1	Ground	Not existed

Is the inspection result normal?

- YES >> Replace the A/C auto amp.
- NO >> Repair the harnesses or connectors.

## Component Inspection

INFOID:000000005490053

## 1.CHECK SUNLOAD SENSOR

1. Turn the ignition switch ON.
2. Check the input voltage from sunload sensor between A/C auto amp. harness connector and the ground. Refer to the applicable table for the normal value.

(+) (V)		(-)
A/C auto amp.		—
Connector	Terminal	
M51	25	Ground

# SUNLOAD SENSOR

< DTC/CIRCUIT DIAGNOSIS >

[AUTOMATIC AIR CONDITIONING]

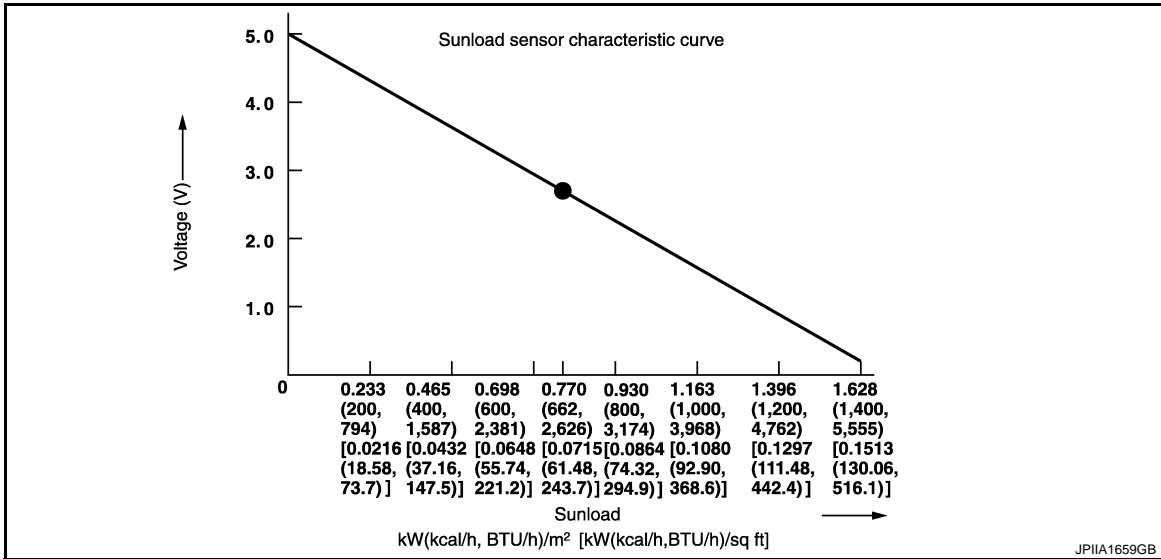

**NOTE:**

- When checking indoors, use a lamp of approximately 60 W. Move the lamp towards and away from the sensor to check.
- The sunload amount produced by direct sunshine in fair weather is equivalent to approximately 0.77 kW/m<sup>2</sup> (662 kcal/m<sup>2</sup>·h).

Is the inspection result normal?

- YES >> INSPECTION END
- NO >> Replace the sunload sensor.

A  
B  
C  
D  
E  
F  
G  
H  
J  
K  
L  
M  
N  
O  
P

HAC

# AIR MIX DOOR MOTOR

< DTC/CIRCUIT DIAGNOSIS >

[AUTOMATIC AIR CONDITIONING]

## AIR MIX DOOR MOTOR

### Description

INFOID:000000005490054

#### COMPONENT DESCRIPTION

- The air mix door motor (1) is installed to the A/C unit assembly.
- The step motor system is adopted for air mix door motor.
- When a drive signal is input from auto amp. to door motor, a step motor built into the door the door motor rotates according to the drive signal, and then stops at the position of target door.

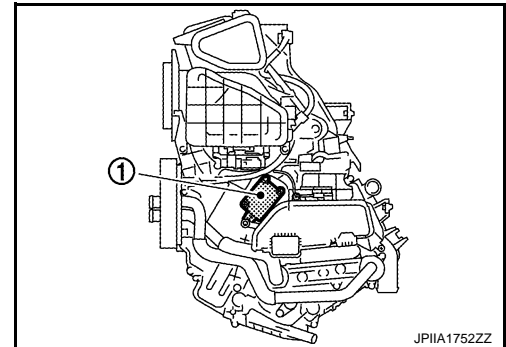

#### DRIVE SYSTEM OF STEP MOTOR TYPE DOOR MOTOR

- Motor is actuated in sequence by energizing four drive coils.
- Rotation direction can be changed by changing pattern of excitation.

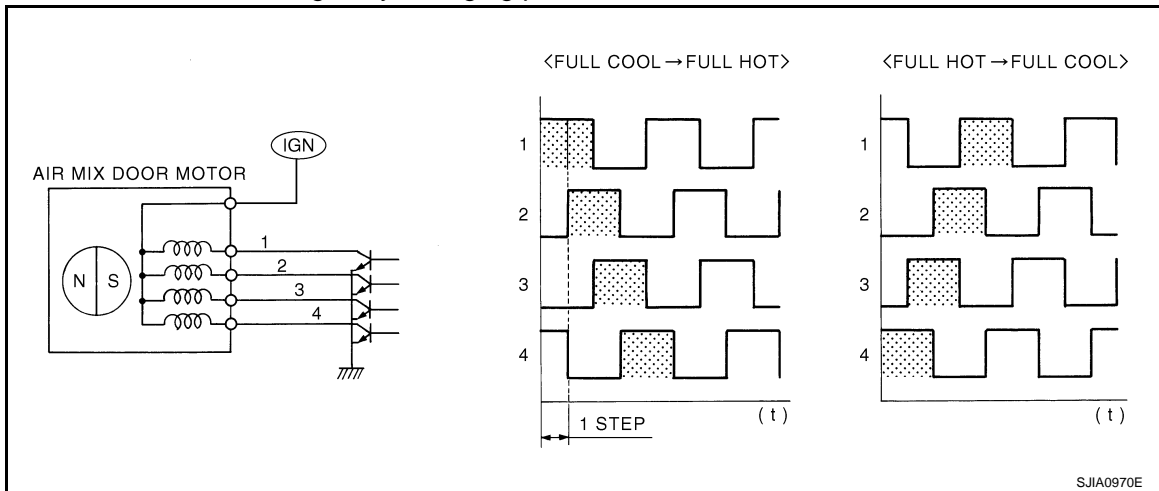

### Diagnosis Procedure

INFOID:000000005490055

#### 1. CHECK FUSE

Check 10A fuse [No. 2, located in the fuse block (J/B)].

##### NOTE:

Refer to [PG-97. "Fuse, Connector and Terminal Arrangement"](#).

Is the inspection result normal?

YES >> GO TO 2.

NO >> Replace fuse after repairing the applicable circuit.

#### 2. CHECK POWER SUPPLY OF AIR MIX DOOR MOTOR

1. Turn the ignition switch OFF.
2. Disconnect the air mix door motor connector.
3. Turn the ignition switch ON.
4. Check voltage between air mix door motor harness connector and the ground.

(+)		(-)	Voltage (Approx.)
Air mix door motor		—	
Connector	Terminal		
M55	2	Ground	Battery voltage

# AIR MIX DOOR MOTOR

[AUTOMATIC AIR CONDITIONING]

< DTC/CIRCUIT DIAGNOSIS >

Is the inspection result normal?

- YES >> GO TO 3.
- NO >> Repair the harnesses or connectors.

## 3.CHECK CONTINUITY BETWEEN A/C AUTO AMP. AND AIR MIX DOOR MOTOR

1. Turn the ignition switch OFF.
2. Disconnect the A/C auto amp. connector.
3. Check continuity between air mix door motor harness connector and the ground.

Air mix door motor		A/C auto amp.		Continuity
Connector	Terminal	Connector	Terminal	
M55	3	M50	17	Existed
	6		18	
	1		19	
	4		20	

Is the inspection result normal?

- YES >> GO TO 4.
- NO >> Repair the harnesses or connectors.

## 4.CHECK CONTINUITY BETWEEN A/C AUTO AMP. AND GROUND

Check continuity between A/C auto amp. harness connector and the ground.

A/C auto amp.		—	Continuity
Connector	Terminal		
M50	17	Ground	Not Existed
	18		
	19		
	20		

Is the inspection result normal?

- YES >> GO TO 5.
- NO >> Repair the harnesses or connectors.

## 5.CHECK AIR MIX DOOR MOTOR

Perform the component inspection of air mix door motor. Refer to [HAC-47. "Component Inspection"](#).

Is the inspection result normal?

- YES >> Replace the A/C auto amp.
- NO >> Replace the air mix door motor.

## Component Inspection

INFOID:000000005490056

### 1.CHECK AIR MIX DOOR MOTOR

1. Turn the ignition switch OFF.
2. Remove the air mix door motor. Refer to [HAC-151. "Exploded View"](#).
3. Check the resistance between air mix door motor terminals. Refer to the applicable table for the normal value.

Terminal		Resistance: Ω (Approx.)
2	1	90
	3	
	4	
	6	

## AIR MIX DOOR MOTOR

< DTC/CIRCUIT DIAGNOSIS >

[AUTOMATIC AIR CONDITIONING]

---

Is the inspection result normal?

YES >> INSPECTION END

NO >> Replace the air mix door motor.



# MODE DOOR MOTOR

< DTC/CIRCUIT DIAGNOSIS >

[AUTOMATIC AIR CONDITIONING]

## MODE DOOR MOTOR

### Description

INFOID:000000005490057

### COMPONENT DESCRIPTION

- The mode door motor (1) is installed to the A/C unit assembly.
- Step motor system is adopted for the mode door motor.
- When a drive signal is input from auto amp. to door motor, a step motor built into the door motor rotates according to the drive signal, and then stops at the position of target door.

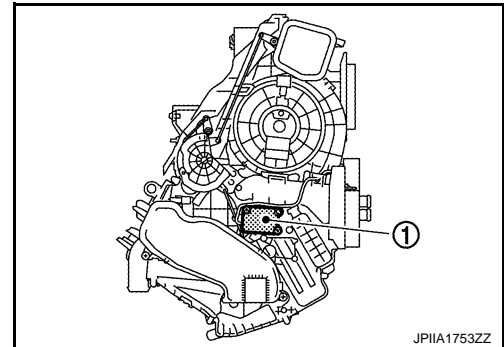

### DRIVE SYSTEM OF STEP MOTOR TYPE DOOR MOTOR

- Motor is actuated in sequence by energizing four drive coils.
- Rotation direction can be changed by changing pattern of excitation.

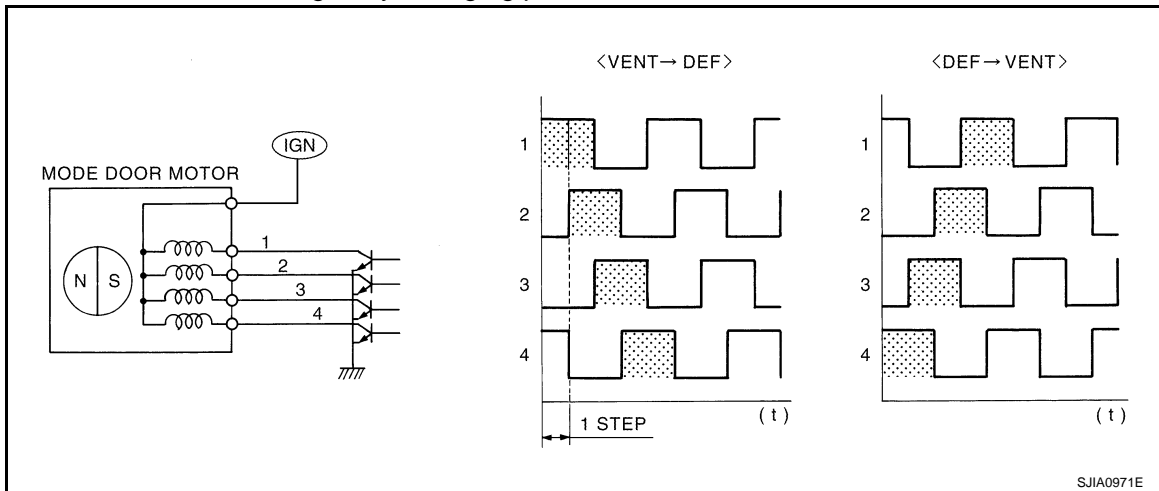

### Diagnosis Procedure

INFOID:000000005490058

#### 1. CHECK FUSE

Check 10A fuse [No. 2, located in the fuse block (J/B)].

#### NOTE:

Refer to [PG-97, "Fuse, Connector and Terminal Arrangement"](#).

Is inspection result normal?

YES >> GO TO 2.

NO >> Replace fuse after repairing the applicable circuit.

#### 2. CHECK POWER SUPPLY OF MODE DOOR MOTOR

1. Turn the ignition switch OFF.
2. Disconnect the mode door motor connector.
3. Turn the ignition switch ON.
4. Check voltage between mode door motor harness connector and the ground.

(+)		(-)	Voltage (Approx.)
Connector	Terminal	—	
M56	5	Ground	Battery voltage

A  
B  
C  
D  
E  
F  
G  
H  
HAC  
J  
K  
L  
M  
N  
O  
P

# MODE DOOR MOTOR

[AUTOMATIC AIR CONDITIONING]

< DTC/CIRCUIT DIAGNOSIS >

Is the inspection result normal?

- YES >> GO TO 3.
- NO >> Repair the harnesses or connectors.

## 3.CHECK CONTINUITY BETWEEN A/C AUTO AMP. AND MODE DOOR MOTOR

1. Turn the ignition switch OFF.
2. Disconnect the A/C auto amp. connector.
3. Check continuity between mode door motor harness connector and A/C auto amp. harness connector.

Mode door motor		A/C auto amp.		Continuity
Connector	Terminal	Connector	Terminal	
M56	1	M51	32	Existed
	2		31	
	3		30	
	4		29	

Is the inspection result normal?

- YES >> GO TO 4.
- NO >> Repair the harnesses or connectors.

## 4.CHECK CONTINUITY BETWEEN A/C AUTO AMP. AND GROUND

Check continuity between A/C auto amp. harness connector and the ground.

A/C auto amp.		—	Continuity
Connector	Terminal		
M51	29	Ground	Not existed
	30		
	31		
	32		

Is the inspection result normal?

- YES >> GO TO 5.
- NO >> Repair the harnesses or connectors.

## 5.CHECK MODE DOOR MOTOR

Perform the component inspection of mode door motor. Refer to [HAC-50. "Component Inspection"](#).

Is inspection result normal?

- YES >> Replace the A/C auto amp.
- NO >> Replace the mode door motor.

## Component Inspection

INFOID:000000005490059

### 1.CHECK MODE DOOR MOTOR

1. Turn the ignition switch OFF.
2. Disconnect the mode door motor connector.
3. Check the resistance between mode door motor terminals. Refer to the applicable table for the normal value.

Terminal		Resistance: $\Omega$ (Approx.)
5	1	90
	2	
	3	
	4	

# MODE DOOR MOTOR

[AUTOMATIC AIR CONDITIONING]

< DTC/CIRCUIT DIAGNOSIS >

Is the inspection result normal?

YES >> INSPECTION END

NO >> GO TO 2.

## 2. CHECK CONTINUITY MODE DOOR MOTOR SUB HARNESS

Check the sub harness continuity with the following figure.

Is the inspection result normal?

YES >> Replace the mode door motor.

NO >> Repair the harnesses or connectors.

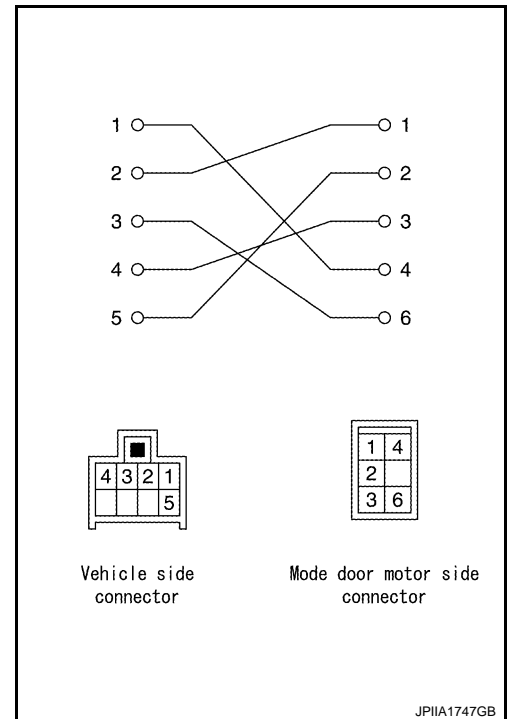

A  
B  
C  
D  
E  
F  
G  
H  
J  
K  
L  
M  
N  
O  
P

HAC

# INTAKE DOOR MOTOR

< DTC/CIRCUIT DIAGNOSIS >

[AUTOMATIC AIR CONDITIONING]

## INTAKE DOOR MOTOR

### Description

INFOID:000000005490060

#### COMPONENT DESCRIPTION

- The intake door motor (1) is installed to A/C unit assembly.

← : Vehicle front

- The A/C auto amp. sends the control signal to Intake door motor. When intake door motor receives the control signal, intake door is moved to appropriate position by PBR (Potentio Balance Resistor) opening angle indication signal.

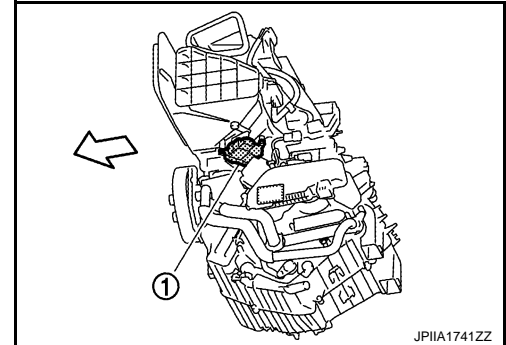

#### Intake door motor circuit

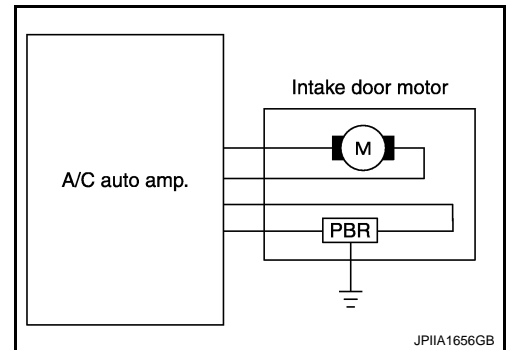

### Diagnosis Procedure

INFOID:000000005490061

#### POWER SUPPLY CIRCUIT

##### 1. CHECK INTAKE DOOR MOTOR DRIVE SIGNAL

- Turn the ignition switch ON.
- Check voltage between intake door motor harness connector and the ground when intake switch is operated.

(+)		(-)	Condition	Voltage (Approx.)
Connector	Terminal	—		
M54	5	Ground	FRE → REC	12 V
	6		REC → FRE	

#### Is inspection result normal?

- YES >> GO TO 4.  
NO >> GO TO 2.

##### 2. CHECK CONTINUITY BETWEEN A/C AUTO AMP. AND INTAKE DOOR MOTOR

- Turn the ignition switch OFF.
- Disconnect the A/C auto amp. connector.
- Disconnect the intake door motor connector.
- Check continuity between A/C auto amp. harness connector and intake door motor harness connector.

# INTAKE DOOR MOTOR

< DTC/CIRCUIT DIAGNOSIS >

[AUTOMATIC AIR CONDITIONING]

Intake door motor		A/C auto amp.		Continuity
Connector	Terminal	Connector	Terminal	
M54	5	M50	13	Existed
	6		12	

Is inspection result normal?

YES >> GO TO 3.

NO >> Repair the harnesses or connectors.

## 3.CHECK CONTINUITY BETWEEN INTAKE DOOR MOTOR AND GROUND

Check continuity between intake door motor harness connector and the ground.

Intake door motor		—	Continuity
Connector	Terminal		
M54	5	Ground	Not existed
	6		

Is inspection result normal?

YES >> Replace the A/C auto amp.

NO >> Repair the harnesses or connectors.

## 4.CHECK INTAKE DOOR MOTOR

Perform the intake door motor component inspection. Refer to [HAC-55, "Component Inspection"](#).

Is inspection result normal?

YES >> Replace the A/C auto amp.

NO >> Replace the intake door motor.

## PBR CIRCUIT

### 1.CHECK POWER SUPPLY OF INTAKE DOOR MOTOR PBR

1. Turn the ignition switch ON.
2. Check voltage between intake door motor harness connector and the ground.

(+)		(-)	Voltage (Approx.)
Intake door motor		—	
Connector	Terminal		
M54	1	Ground	5 V

Is inspection result normal?

YES >> GO TO 4.

NO >> GO TO 2.

### 2.CHECK CONTINUITY BETWEEN INTAKE DOOR MOTOR AND A/C AUTO AMP.-1

1. Turn the ignition switch OFF.
2. Disconnect the intake door motor connector.
3. Disconnect the A/C auto amp. connector.
4. Check continuity between intake door motor harness connector and A/C auto amp. harness connector.

Intake door motor		A/C auto amp.		Continuity
Connector	Terminal	Connector	Terminal	
M54	1	M50	3	Existed

Is inspection result normal?

YES >> GO TO 3.

NO >> Repair the harnesses or connectors.

# INTAKE DOOR MOTOR

< DTC/CIRCUIT DIAGNOSIS >

[AUTOMATIC AIR CONDITIONING]

## 3. CHECK CONTINUITY INTAKE DOOR MOTOR AND GROUND-1

Check continuity between intake door motor and the ground.

Intake door motor		—	Continuity
Connector	Terminal		
M54	1	Ground	Not existed

Is inspection result normal?

YES >> Replace the A/C auto amp.

NO >> Repair the harnesses or connectors.

## 4. CHECK INTAKE DOOR MOTOR PBR GROUND

1. Turn the ignition switch OFF.
2. Disconnect the A/C auto amp. connector.
3. Check continuity between intake door motor harness connector and the ground.

Intake door motor		A/C auto amp.		Continuity
Connector	Terminal	Connector	Terminal	
M54	3	M50	6	Existed

Is inspection result normal?

YES >> GO TO 5.

NO >> Repair the harnesses or connectors.

## 5. CHECK INTAKE DOOR MOTOR PBR FEEDBACK SIGNAL

1. Connect the A/C auto amp. connector.
2. Connect the intake door motor connector.
3. Turn the ignition switch ON.
4. Check voltage between A/C auto amp. and the ground when intake switch is operated.

(+)		(-)	Condition	Voltage (Approx.)
A/C auto amp.		—		
Connector	Terminal			
M54	1	Ground	FRE	4.5 V
			REC	0.5 V

Is inspection result normal?

YES >> Replace the A/C auto amp.

NO >> GO TO 6.

## 6. CHECK CONTINUITY INTAKE DOOR MOTOR AND A/C AUTO AMP.-2

1. Turn the ignition switch OFF.
2. Disconnect the A/C auto amp. connector.
3. Disconnect the intake door motor connector.
4. Check continuity between intake door motor and A/C auto amp.

Intake door motor		A/C auto amp.		Continuity
Connector	Terminal	Connector	Terminal	
M54	2	M51	26	Existed

Is inspection result normal?

YES >> GO TO 7.

NO >> Repair the harnesses or connectors.

## 7. CHECK CONTINUITY INTAKE DOOR MOTOR AND GROUND-2

Check continuity between intake door motor harness connector and the ground.

# INTAKE DOOR MOTOR

< DTC/CIRCUIT DIAGNOSIS >

[AUTOMATIC AIR CONDITIONING]

Intake door motor		—	Continuity
Connector	Terminal		
M54	2	Ground	Not existed

Is inspection result normal?

- YES >> Replace the intake door motor.  
NO >> Repair the harnesses or connectors.

## Component Inspection

INFOID:000000005490062

### 1. CHECK INTAKE DOOR MOTOR

1. Turn the ignition switch OFF.
2. Disconnect the intake door motor connector.
3. Supply to the intake door motor terminal directly, confirm the motor operation by listening the sound or by visually.

Terminal		Operation
(+)	(-)	
5	6	To REC
6	5	To FRE

Is inspection result normal?

- YES >> INSPECTION END  
NO >> Replace the intake door motor.

A  
B  
C  
D  
E  
F  
G  
H  
J  
K  
L  
M  
N  
O  
P

HAC

## BLOWER MOTOR

### Description

INFOID:000000005490063

#### BLOWER MOTOR

- The blower motor is installed in the RH side of A/C unit assembly.
- The blower motor adopts the forcible air cooling system and one-touch installation system without any screws.

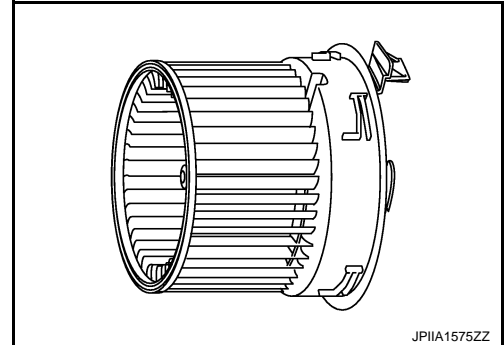

#### POWER TRANSISTOR

- The power transistor attached to A/C unit assembly.

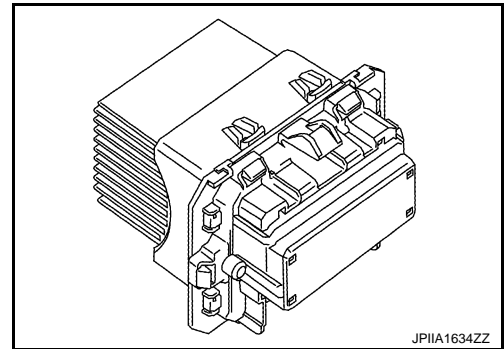

- The power transistor controls the transmitting voltage to blower motor base on the gate voltage from A/C auto amp.
- The power transistor is set for low voltage drop, therefore it dose not require high relay while transmitting max voltage to blower motor.

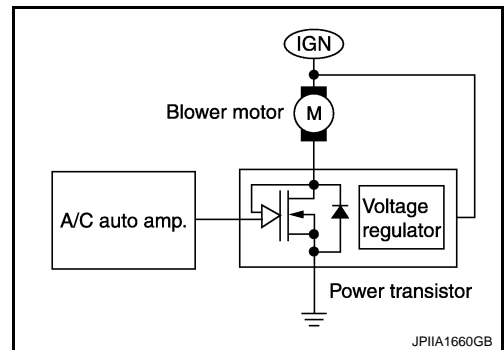

### Component Function Check

INFOID:000000005490064

#### 1.CHECK OPERATION

1. Warm up the engine.
2. Operate the fan control switch. Check that the fan speed and indicator unit are switched for all fan speeds.

#### Does it operate normally?

- YES >> INSPECTION END  
NO >> Perform the diagnosis for the blower motor. Refer to [HAC-56. "Diagnosis Procedure"](#).

### Diagnosis Procedure

INFOID:000000005490065

#### 1.CHECK FUSE

Check 15A fuses [Nos. 15 and 17, located in the fuse block (J/B)].

#### **NOTE:**

Refer to [PG-97. "Fuse, Connector and Terminal Arrangement"](#).

#### Is inspection result normal?



# BLOWER MOTOR

[AUTOMATIC AIR CONDITIONING]

## < DTC/CIRCUIT DIAGNOSIS >

- YES >> GO TO 2.  
NO >> Replace the corresponding fuse.

### 2.CHECK POWER SUPPLY OF BLOWER MOTOR

1. Turn the ignition switch OFF.
2. Disconnect the blower motor connector.
3. Turn the ignition switch ON.
4. Check voltage between blower motor harness connector and the ground.

(+)		(-)	Voltage (Approx.)
Blower motor		—	
Connector	Terminal		
M39	1	Ground	Battery voltage

Is the inspection result normal?

- YES >> GO TO 4.  
NO >> GO TO 3.

### 3.CHECK BLOWER MOTOR RELAY

1. Turn the ignition switch OFF.
2. Check the blower motor relay. Refer to [HAC-59, "Component Inspection"](#).

Is inspection result normal?

- YES >> Repair the harness or connector between blower motor and fuse.  
NO >> Replace the blower motor relay.

### 4.CHECK VOLTAGE BETWEEN POWER TRANSISTOR AND GROUND

1. Connect the blower motor connector.
2. Disconnect the power transistor connector.
3. Turn the ignition switch ON.
4. Check voltage between power transistor harness connector and the ground.

(+)		(-)	Voltage (Approx.)
Blower motor		—	
Connector	Terminal		
M82	1	Ground	Battery voltage

Is inspection result normal?

- YES >> GO TO 6.  
NO >> GO TO 5.

### 5.CHECK CONTINUITY BETWEEN BLOWER MOTOR AND POWER TRANSISTOR

1. Turn the ignition switch OFF.
2. Disconnect the blower motor connector.
3. Check continuity between blower motor harness connector and power transistor harness connector.

Blower motor		Power transistor		Continuity
Connector	Terminal	Connector	Terminal	
M39	2	M82	1	Existed

Is the inspection result normal?

- YES >> Replace the blower motor.  
NO >> Repair the harnesses or connectors.

### 6.CHECK VOLTAGE BETWEEN POWER TRANSISTOR AND GROUND

Check voltage between power transistor harness connector and the ground.

# BLOWER MOTOR

< DTC/CIRCUIT DIAGNOSIS >

[AUTOMATIC AIR CONDITIONING]

(+)		(-)	Voltage (Approx.)
Power transistor		—	
Connector	Terminal		
M82	4	Ground	

Is inspection result normal?

YES >> GO TO 7.

NO >> Replace the harness or connector between power transistor and fuse.

## 7. CHECK CONTINUITY BETWEEN POWER TRANSISTOR AND GROUND

Check continuity between power transistor harness connector and the ground.

Blower motor		—	Continuity
Connector	Terminal		
M82	3	Ground	Existed

Is inspection result normal?

YES >> GO TO 8.

NO >> Repair the harnesses or connectors.

## 8. CHECK A/C AUTO AMP. OUTPUT SIGNAL

1. Connect the blower motor connector and the A/C auto amp. connector.
2. Turn the ignition switch ON.
3. Set the mode position to VENT.
4. Change fan speed from Lo to Hi, and check duty ratios between blower motor harness connector and the ground by using an oscilloscope.

### NOTE:

Calculate the drive signal duty ratio as shown in the figure.

T2 = Approx. 1.6 ms

(+)		(-)	Condition	Duty ratio (Approx.)	Output waveform
Blower motor		—			
Connector	Terminal		Ground	Fan speed (manual, VENT mode)	
M82	2	1st		26%	
		2nd		34%	
		3rd		41%	
		4th		51%	
		5th		62%	
		6th		73%	
		7th	82%		

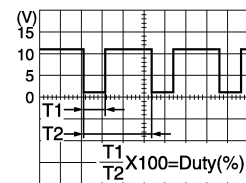

JPIIA1646GB

Is the inspection result normal?

YES >> GO TO 10.

NO >> GO TO 9.

## 9. CHECK CONTINUITY BETWEEN POWER TRANSISTOR AND A/C AUTO AMP.

1. Turn the ignition switch OFF.
2. Disconnect the power transistor connector.
3. Disconnect the A/C auto amp. connector.
4. Check continuity between power transistor harness connector and A/C auto amp. harness connector.

# BLOWER MOTOR

[AUTOMATIC AIR CONDITIONING]

< DTC/CIRCUIT DIAGNOSIS >

Power transistor		A/C auto amp.		Continuity
Connector	Terminal	Connector	Terminal	
M82	2	M51	36	Existed

Is the inspection result normal?

- YES >> Replace the A/C auto amp.
- NO >> Repair the harnesses or connectors.

## 10.CHECK CONTINUITY POWER TRANSISTOR SUB HARNESS

Check the sub harness continuity with the following figure.

Is the inspection result normal?

- YES >> Replace the power transistor.
- NO >> Repair the harnesses or connectors.

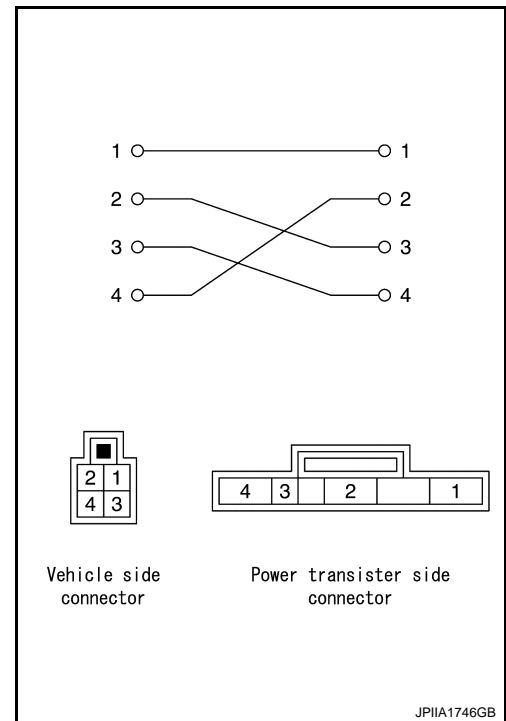

## Component Inspection

INFOID:000000005490066

### BLOWER MOTOR

#### 1.CHECK BLOWER MOTOR

1. Remove the blower motor. Refer to [VTL-13. "Exploded View"](#).
2. Check that there is not any mixing foreign object in the blower motor.

Is the inspection result normal?

- YES >> GO TO 2.
- NO >> Replace the blower motor.

#### 2.CHECK BLOWER MOTOR

Check that there is not breakage or damage in the blower motor.

Is the inspection result normal?

- YES >> GO TO 3.
- NO >> Replace the blower motor.

#### 3.CHECK BLOWER MOTOR

Check that the blower motor turns smoothly.

Is the inspection result normal?

- YES >> INSPECTION END
- NO >> Replace the blower motor.

### BLOWER MOTOR RELAY

# BLOWER MOTOR

< DTC/CIRCUIT DIAGNOSIS >

[AUTOMATIC AIR CONDITIONING]

## 1. CHECK BLOWER MOTOR

1. Remove the blower motor relay. Refer to [PG-97. "Fuse, Connector and Terminal Arrangement"](#).
2. Check the continuity between the blower motor relay terminal 3 and 5 when the voltage is supplied between terminal 1 and 2.

Blower motor relay		Voltage	Continuity
Terminal			
3	5	ON	Existed
		OFF	Not existed

Is the inspection result normal?

YES >> INSPECTION END

NO >> Replace the blower motor relay.

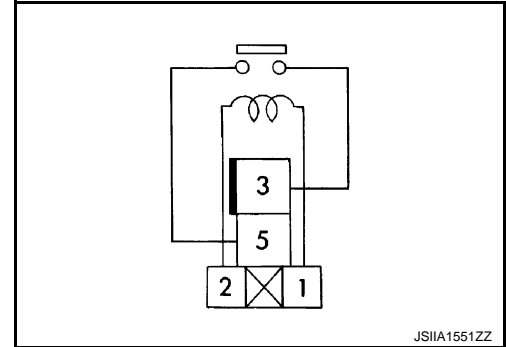

# MAGNET CLUTCH

< DTC/CIRCUIT DIAGNOSIS >

[AUTOMATIC AIR CONDITIONING]

## MAGNET CLUTCH

### Description

INFOID:000000005490067

- The magnet clutch is the device that drives the compressor with the signal from IPDM E/R.
- Compressor is driven by the magnet clutch which is charged magnetic force by electrified.
- IPDM E/R controls magnet clutch by turning the built in A/C relay to ON ⇔ OFF according to ECM request.

### Component Function Check

INFOID:000000005490068

#### 1.CHECK MAGNET CLUTCH OPERATION

Perform auto active test of IPDM E/R. Refer to [PCS-11, "Diagnosis Description"](#) (WITH I-KEY) or [PCS-41, "Diagnosis Description"](#) (WITHOUT I-KEY).

Does it operate normally?

YES >> INSPECTION END

NO >> Go to diagnosis procedure. Refer to [HAC-61, "Diagnosis Procedure"](#).

### Diagnosis Procedure

INFOID:000000005490069

#### 1.CHECK MAGNET CLUTCH

1. Turn the ignition switch OFF.
2. Disconnect the magnet clutch connector.
3. Directly apply the battery voltage to the magnet clutch. Check for operation visually and by sound.

Does it operate normally?

YES >> GO TO 2.

NO >> Replace the compressor.

#### 2.CHECK MAGNET CLUTCH CIRCUIT CONTINUITY

1. Turn the ignition switch OFF.
2. Disconnect the IPDM E/R connector.
3. Check continuity between magnet clutch harness connector and IPDM E/R harness connector.

IPDM E/R		Magnet clutch		Continuity
Connector	Terminal	Connector	Terminal	
E15	56	F17	1	Existed

Is the inspection result normal?

YES >> GO TO 3.

NO >> Repair the harnesses and connectors.

#### 3.CHECK FUSE

Check 10A fuse (No. 49, located in the IPDM E/R).

**NOTE:**

Refer to [PG-99, "Fuse, Connector and Terminal Arrangement"](#).

Is the inspection result normal?

YES >> Replace the IPDM E/R.

NO >> Replace the fuse after repairing the applicable circuit.

A  
B  
C  
D  
E  
F  
G  
H  
J  
K  
L  
M  
N  
O  
P

HAC

A/C ON SIGNAL

Component Function Check

INFOID:000000005490070

1. CHECK A/C ON SIGNAL

④ With CONSULT-III

1. Turn the ignition switch ON.
2. Select the "COMP REQ SIG" in "DATA MONITOR".
3. Check A/C ON signal when the A/C switch is operated.

Monitor item	Condition		Status
COMP REQ SIG	A/C control	A/C system ON (Indicator ON)	On
		A/C system OFF (Indicator OFF)	Off

Is inspection result normal?

- YES >> INSPECTION END  
 NO >> Refer to [HAC-62, "Diagnosis Procedure"](#).

Diagnosis Procedure

INFOID:000000005490071

1. CHECK A/C SWITCH SIGNAL

1. Turn the ignition switch ON.
2. Check output waveform between A/C auto amp. harness connector and the ground with using oscilloscope.

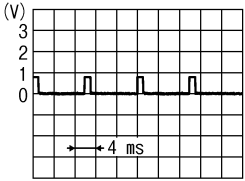
(+)		(-)	Condition	Output waveform
A/C auto amp.		—		
Connector	Terminal			
M51	34	Ground	A/C switch ON	 <p style="text-align: right; font-size: small;">ZJJA1036J</p>

Is inspection result normal?

- YES >> GO TO 2.  
 NO >> Replace the A/C auto amp.

2. CHECK CONTINUITY BETWEEN A/C AUTO AMP. AND BCM

1. Turn the ignition switch OFF.
2. Disconnect the A/C auto amp. connector.
3. Disconnect the BCM connector.
4. Check continuity between A/C auto amp. harness connector and BCM harness connector.

A/C auto amp.		BCM		Continuity
Connector	Terminal	Connector	Terminal	
M51	34	M65 (WITHOUT I-KEY) M68 (WITH I-KEY)	27	Existed

Is inspection result normal?

- YES >> GO TO 3.  
 NO >> Repair the harnesses or connectors.

# A/C ON SIGNAL

< DTC/CIRCUIT DIAGNOSIS >

[AUTOMATIC AIR CONDITIONING]

## 3. CHECK THE CONTINUITY BETWEEN A/C AUTO AMP. AND GROUND

Check continuity between A/C auto amp. harness connector and ground.

A/C auto amp.		—	Continuity
Connector	Terminal		
M51	34	Ground	Not existed

Is inspection result normal?

YES >> Replace the BCM. Refer to [BCS-81. "Exploded View"](#) (WITH I-KEY) or [BCS-146. "Exploded View"](#) (WITHOUT I-KEY).

NO >> Repair the harnesses or connectors.

A  
B  
C  
D  
E  
F  
G  
H  
J  
K  
L  
M  
N  
O  
P

HAC

# BLOWER FAN ON SIGNAL

< DTC/CIRCUIT DIAGNOSIS >

[AUTOMATIC AIR CONDITIONING]

## BLOWER FAN ON SIGNAL

### Component Function Check

INFOID:000000005490072

#### 1.CHECK BLOWER FAN ON SIGNAL

④ With CONSULT-III

1. Turn the ignition switch ON.
2. Select the "FAN REQ SIG" in "DATA MONITOR"
3. Check the fan ON signal when the fan control switch is operated.

Monitor item	Condition	Status
FAN REQ SIG	Fan control switch OFF position	Off
	Except OFF position	On

Is inspection result normal?

YES >> INSPECTION END

NO >> Refer to [HAC-64, "Diagnosis Procedure"](#).

### Diagnosis Procedure

INFOID:000000005490073

#### 1.CHECK BLOWER FAN ON SIGNAL

1. Turn the ignition switch ON.
2. Check output waveform between A/C auto amp. and ground with using the oscilloscope.

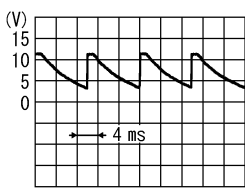
(+)		(-)	Condition	Output waveform
A/C auto amp.		—		
Connector	Terminal			
M51	35	Ground	<ul style="list-style-type: none"> <li>• Ignition switch ON</li> <li>• Fan speed: Manual 1st</li> </ul>	 <p style="text-align: right;">SJIA1425J</p>

Is inspection result normal?

YES >> GO TO 2.

NO >> Replace the A/C auto amp.

#### 2.CHECK CONTINUITY BETWEEN A/C AUTO AMP. AND BCM

1. Turn the ignition switch OFF.
2. Disconnect the A/C auto amp. connector.
3. Disconnect the BCM connector.
4. Check continuity A/C auto amp. harness connector and BCM harness connector.

A/C auto amp.		BCM		Continuity
Connector	Terminal	Connector	Terminal	
M51	35	M65 (WITHOUT I-KEY) M68 (WITH I-KEY)	28	Existed

Is inspection result normal?

YES >> GO TO 3.

NO >> Repair the harnesses or connectors.

#### 3.CHECK CONTINUITY BETWEEN A/C AUTO AMP. AND GROUND

Check continuity between A/C auto amp. harness connector and ground.



# BLOWER FAN ON SIGNAL

< DTC/CIRCUIT DIAGNOSIS >

[AUTOMATIC AIR CONDITIONING]

A/C auto amp.		—	Continuity
Connector	Terminal		
M51	35	Ground	Not existed

Is inspection result normal?

- YES >> Replace the BCM. Refer to [BCS-81. "Exploded View"](#) (WITH I-KEY) or [BCS-146. "Exploded View"](#) (WITHOUT I-KEY).
- NO >> Repair the harnesses or connectors.

A  
B  
C  
D  
E  
F  
G  
H  
J  
K  
L  
M  
N  
O  
P

HAC

# POWER SUPPLY AND GROUND CIRCUIT

< DTC/CIRCUIT DIAGNOSIS >

[AUTOMATIC AIR CONDITIONING]

## POWER SUPPLY AND GROUND CIRCUIT

A/C AUTO AMP.

A/C AUTO AMP. : Diagnosis Procedure

INFOID:000000005490074

### 1. CHECK FUSE

Check 10A fuses [Nos. 2, 13 and 16, located in the fuse block (J/B)].

**NOTE:**

Refer to [PG-97, "Fuse, Connector and Terminal Arrangement"](#).

Is the inspection result normal?

YES >> GO TO 2.

NO >> Replace the fuse after repairing the applicable circuit.

### 2. CHECK A/C AUTO AMP. POWER SUPPLY CIRCUIT-1

1. Turn the ignition switch OFF.
2. Disconnect the A/C auto amp. connector.
3. Check voltage between A/C auto amp. harness connector and the ground.

(+)		(-)	Voltage		
A/C auto amp.		—	Ignition switch position		
Connector	Terminal		OFF	ACC	ON
M50	4	Ground	Battery voltage	Battery voltage	Battery voltage
	5		Approx. 0 V	Approx. 0 V	Battery voltage

Is the inspection result normal?

YES >> GO TO 3.

NO >> Repair the harnesses or connectors.

### 3. CHECK A/C AUTO AMP. POWER SUPPLY CIRCUIT-2

Check voltage A/C auto amp. harness connector and the ground.

(+)		(-)	Voltage		
A/C auto amp.		—	Ignition switch position		
Connector	Terminal		OFF	ACC	ON
M50	9	Ground	Approx. 0 V	Approx. 0 V	Battery voltage

Is inspection result normal?

YES >> GO TO 4.

NO >> GO TO 5.

### 4. CHECK A/C AUTO AMP. CIRCUIT CONTINUITY

1. Turn the ignition switch OFF.
2. Check continuity between A/C auto amp. harness connector and ground.

A/C auto amp.		(-)	Continuity
Connector	Terminal	—	
M50	16	Ground	Existed

Is the inspection result normal?

YES >> INSPECTION END

NO >> Repair the harnesses or connectors.

### 5. CHECK BLOWER MOTOR RELAY POWER SUPPLY

1. Turn the ignition switch OFF.
2. Disconnect the blower motor relay from the fuse block (J/B). Refer to [PG-97, "Fuse, Connector and Terminal Arrangement"](#).

# POWER SUPPLY AND GROUND CIRCUIT

[AUTOMATIC AIR CONDITIONING]

< DTC/CIRCUIT DIAGNOSIS >

- Turn the ignition switch ON.
- Check voltage between the ground and the connector on the fuse block side where blower motor relay was installed. Refer to [PG-95, "Description"](#).

(+)	(-)	Voltage (Approx.)
Fuse block (J/B)	—	
1	Ground	Battery voltage
3		

Is inspection result normal?

YES >> GO TO 6.

NO >> Repair the power supply circuit. Refer to [PG-6, "Wiring Diagram - BATTERY POWER SUPPLY -"](#).

## 6.CHECK BLOWER MOTOR RELAY

Perform the blower motor component inspection. Refer to [HAC-59, "Component Inspection"](#).

Is inspection result normal?

YES >> Repair the harness or connector between blower motor relay and A/C auto amp.

NO >> Replace blower motor relay.

## BCM (BODY CONTROL SYSTEM) (WITH INTELLIGENT KEY SYSTEM)

### BCM (BODY CONTROL SYSTEM) (WITH INTELLIGENT KEY SYSTEM) : Diagnosis Procedure

INFOID:000000005490075

#### 1.CHECK FUSE AND FUSIBLE LINK

Check that the following fuse and fusible link are not blown.

Signal name	Fuse and fusible link No.
Battery power supply	L
	10

Is the fuse fusing?

YES >> Replace the blown fuse or fusible link after repairing the affected circuit if a fuse or fusible link is blown.

NO >> GO TO 2.

#### 2.CHECK POWER SUPPLY CIRCUIT

- Turn ignition switch OFF.
- Disconnect BCM connectors.
- Check voltage between BCM harness connector and ground.

Terminals		Voltage (Approx.)
(+)	(-)	
BCM		Ground Battery voltage
Connector	Terminal	
M118	1	
M119	11	

Is the measurement value normal?

YES >> GO TO 3.

NO >> Repair harness or connector.

#### 3.CHECK GROUND CIRCUIT

Check continuity between BCM harness connector and ground.

# POWER SUPPLY AND GROUND CIRCUIT

< DTC/CIRCUIT DIAGNOSIS >

[AUTOMATIC AIR CONDITIONING]

BCM		Ground	Continuity
Connector	Terminal		
M119	13		Existed

Does continuity exist?

YES >> INSPECTION END

NO >> Repair harness or connector.

**BCM (BODY CONTROL SYSTEM) (WITHOUT INTELLIGENT KEY SYSTEM)**

**BCM (BODY CONTROL SYSTEM) (WITHOUT INTELLIGENT KEY SYSTEM) : Diagnosis Procedure**

INFOID:000000005490076

## 1.CHECK FUSES AND FUSIBLE LINK

Check that the following fuses and fusible link are not fusing.

Signal name	Fuses and fusible link No.
Battery power supply	10
	J
ACC power supply	20
Ignition power supply	1

Is the fuse fusing?

YES >> Replace the blown fuse or fusible link after repairing the affected circuit if a fuse or fusible link is blown.

NO >> GO TO 2.

## 2.CHECK POWER SUPPLY CIRCUIT

1. Turn ignition switch OFF.
2. Disconnect BCM connectors.
3. Check voltage between BCM harness connector and ground.

Terminals		(-)	Ignition switch position		
(+)			OFF	ACC	ON
BCM		Ground			
Connector	Terminal				
M109	70		Battery voltage	Battery voltage	Battery voltage
	57				
M107	11	Approx. 0 V	Battery voltage	Battery voltage	
	38	Approx. 0 V	Approx. 0 V	Battery voltage	

Is the measurement value normal?

YES >> GO TO 3.

NO >> Repair harness or connector.

## 3.CHECK GROUND CIRCUIT

Check continuity between BCM harness connector and ground.

BCM		Ground	Continuity
Connector	Terminal		
M109	67		Existed

Does continuity exist?

# POWER SUPPLY AND GROUND CIRCUIT

< DTC/CIRCUIT DIAGNOSIS >

[AUTOMATIC AIR CONDITIONING]

YES >> INSPECTION END  
NO >> Repair harness or connector.

A

B

C

D

E

F

G

H

**HAC**

J

K

L

M

N

O

P

## A/C AUTO AMP.

### Description

INFOID:000000005490077

#### A/C AUTO AMP. (AIR CONDITIONER AUTOMATIC AMPLIFIER)

- The A/C auto amp. has a built-in microcomputer which processes information sent from various sensors needed for air conditioner operation.
- The air mix door motor, mode door motor, intake door motor, blower motor and the compressor are then controlled.
- The A/C auto amp. is unitized with control mechanism. Signal from various switches are directly entered into A/C auto amp.
- Self-diagnosis functions are also built into A/C auto amp. to provide quick check of malfunctions in the auto air conditioner system.

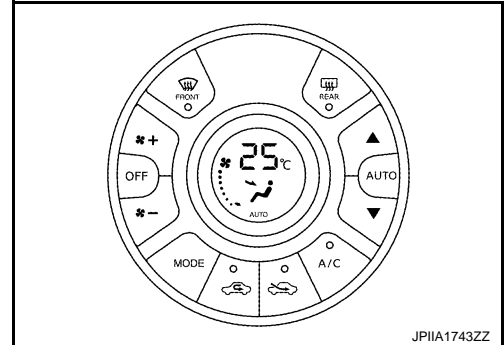

### Component Function Check

INFOID:000000005490078

#### 1. CHECK OPERATION

1. Confirm that "AUTO" is indicated on the display by operating the AUTO switch.
2. Operate the temperature control switch. Check that the fan speed or discharge air changes (the discharge air temperature or fan speed varies depending on the ambient temperature, in-vehicle temperature, and set temperature).

#### Does it operate normally?

YES >> INSPECTION END

NO >> Perform the diagnosis for the A/C auto amp. Refer to [HAC-70. "Diagnosis Procedure"](#).

### Diagnosis Procedure

INFOID:000000005490079

#### 1. CHECK A/C AUTO AMP. POWER SUPPLY CIRCUIT AND GROUND CIRCUIT

Check A/C auto amp. power supply circuit and ground circuit. Refer to [HAC-66. "A/C AUTO AMP. : Diagnosis Procedure"](#).

#### Is the inspection result normal?

YES >> INSPECTION END

NO >> Repair or replace parts depending on the inspection results.

# A/C AUTO AMP.

< ECU DIAGNOSIS INFORMATION >

[AUTOMATIC AIR CONDITIONING]

## ECU DIAGNOSIS INFORMATION

A/C AUTO AMP.

Reference Value

INFOID:000000005490080

### TERMINAL LAYOUT

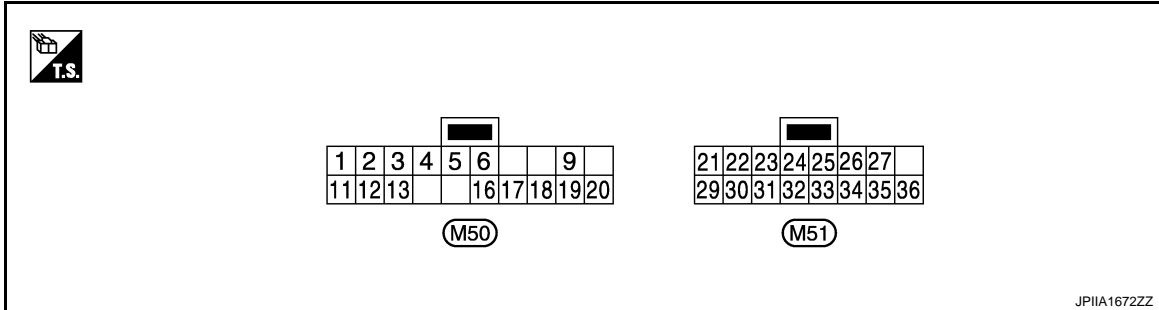

### PHYSICAL VALUES

Terminal No. (Wire color)		Description		Condition	Value (Approx.)
+	-	Signal name	Input/ Output		
2 (R)	Ground	A/C auto amp. connecting recognition signal	Output	Ignition switch ON	5 V
3 (R)	Ground	Intake door motor PBR power supply	Output	Ignition switch ON	5 V
4 (LG)	Ground	Battery power supply	—	Ignition switch OFF	Battery voltage
5 (O)	Ground	IGN power supply	—	Ignition switch ON	Battery voltage
6 (R/W)	Ground	Sensor ground	—	Ignition switch ON	0 V
9 (Y)	Ground	IGN2 power supply	—	Ignition switch ON	Battery voltage
12 (L)	Ground	FRE	Intake door motor drive signal	• Ignition switch ON • Intake switch REC → FRE	12 V
				• Ignition switch ON • Intake switch FRE → REC	0 V
13 (G)	Ground	REC	Intake door motor drive signal	• Ignition switch ON • Intake switch REC → FRE	0 V
				• Ignition switch ON • Intake switch FRE → REC	12 V
16 (B)	Ground	Ground	—	Ignition switch ON	0 V
17 (BR)	Ground	A/MIX drive 4	Air mix door motor drive signal	Output	<ul style="list-style-type: none"> <li>Ignition switch ON</li> <li>Right after the temperature control switch operation</li> </ul>
18 (SB)		A/MIX drive 3			
19 (GR)		A/MIX drive 2			
20 (P)		A/MIX drive 1			



JPIIA1647GB

# A/C AUTO AMP.

< ECU DIAGNOSIS INFORMATION >

[AUTOMATIC AIR CONDITIONING]

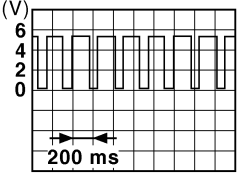
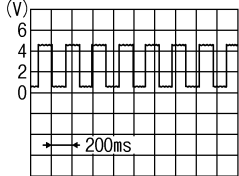
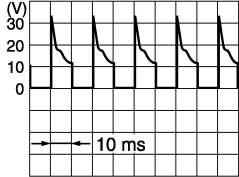
Terminal No. (Wire color)		Description		Condition	Value (Approx.)
+	-	Signal name	Input/ Output		
21 (BR)	Ground	Engine coolant temperature signal	Input	<ul style="list-style-type: none"> <li>Ignition switch ON</li> <li>Engine idling [Approximately 20°C (68°F)]</li> </ul>	 <p style="text-align: right; font-size: small;">PKID0590E</p>
				<ul style="list-style-type: none"> <li>Ignition switch ON</li> <li>Engine idling [Approximately 80°C (176°F)]</li> </ul>	 <p style="text-align: right; font-size: small;">SKIB3651J</p>
22 (V/W)	Ground	Ambient sensor signal	Input	—	0 – 4.8 V Output voltage varies with ambient temperature
23 (O)	Ground	Intake sensor signal	Input	—	0 – 4.8 V Output voltage varies with intake temperature
24 (G)	Ground	In-vehicle sensor signal	Input	—	0 – 4.8 V Output voltage varies with in-vehicle temperature
25 (P)	Ground	Sunload sensor signal	Input	—	0 – 4.8 V Output voltage varies with sun load
26 (SB)	Ground	Intake door motor PBR feedback signal	Input	<ul style="list-style-type: none"> <li>Ignition switch ON</li> <li>REC position</li> </ul>	0.5 V
				<ul style="list-style-type: none"> <li>Ignition switch ON</li> <li>FRE position</li> </ul>	4.5 V
29 (GR)	Ground	MODE drive 4	Mode door motor drive signal	<ul style="list-style-type: none"> <li>Ignition switch ON</li> <li>Right after MODE switch operation</li> </ul>	 <p style="text-align: right; font-size: small;">JPIIA1647GB</p>
30 (W)		MODE drive 3			
31 (Y)		MODE drive 2			
32 (V)		MODE drive 1			



# A/C AUTO AMP.

< ECU DIAGNOSIS INFORMATION >

[AUTOMATIC AIR CONDITIONING]

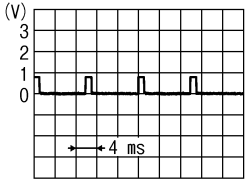
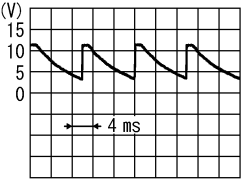
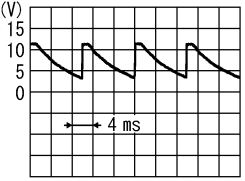
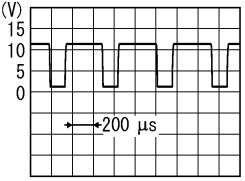
Terminal No. (Wire color)		Description		Condition	Value (Approx.)
+	-	Signal name	Input/ Output		
34 (Y/G)	Ground	A/C ON signal	Output	<ul style="list-style-type: none"> <li>Ignition switch ON</li> <li>A/C switch: ON</li> </ul>	 <p style="text-align: right;">ZJIA1036J</p>
				<ul style="list-style-type: none"> <li>Ignition switch ON</li> <li>A/C switch: OFF</li> </ul>	 <p style="text-align: right;">SJIA1425J</p>
35 (G/W)	Ground	Fan ON signal	Output	<ul style="list-style-type: none"> <li>Ignition switch ON</li> <li>Fan speed: 1st speed (manual)</li> </ul>	 <p style="text-align: right;">SJIA1425J</p>
36 (GR/B)	Ground	Blower motor control signal	Output	<ul style="list-style-type: none"> <li>Ignition switch ON</li> <li>Fan speed: 1st speed (manual)</li> </ul>	 <p style="text-align: right;">ZJIA0863J</p>

A  
B  
C  
D  
E  
F  
G  
H  
HAC  
J  
K  
L  
M  
N  
O  
P

# A/C AUTO AMP.

< ECU DIAGNOSIS INFORMATION >

[AUTOMATIC AIR CONDITIONING]

## Wiring Diagram - AUTOMATIC AIR CONDITIONING SYSTEM -

INFOID:000000005490081

: With Intelligent Key  
 : Without Intelligent Key

### AUTOMATIC AIR CONDITIONING SYSTEM

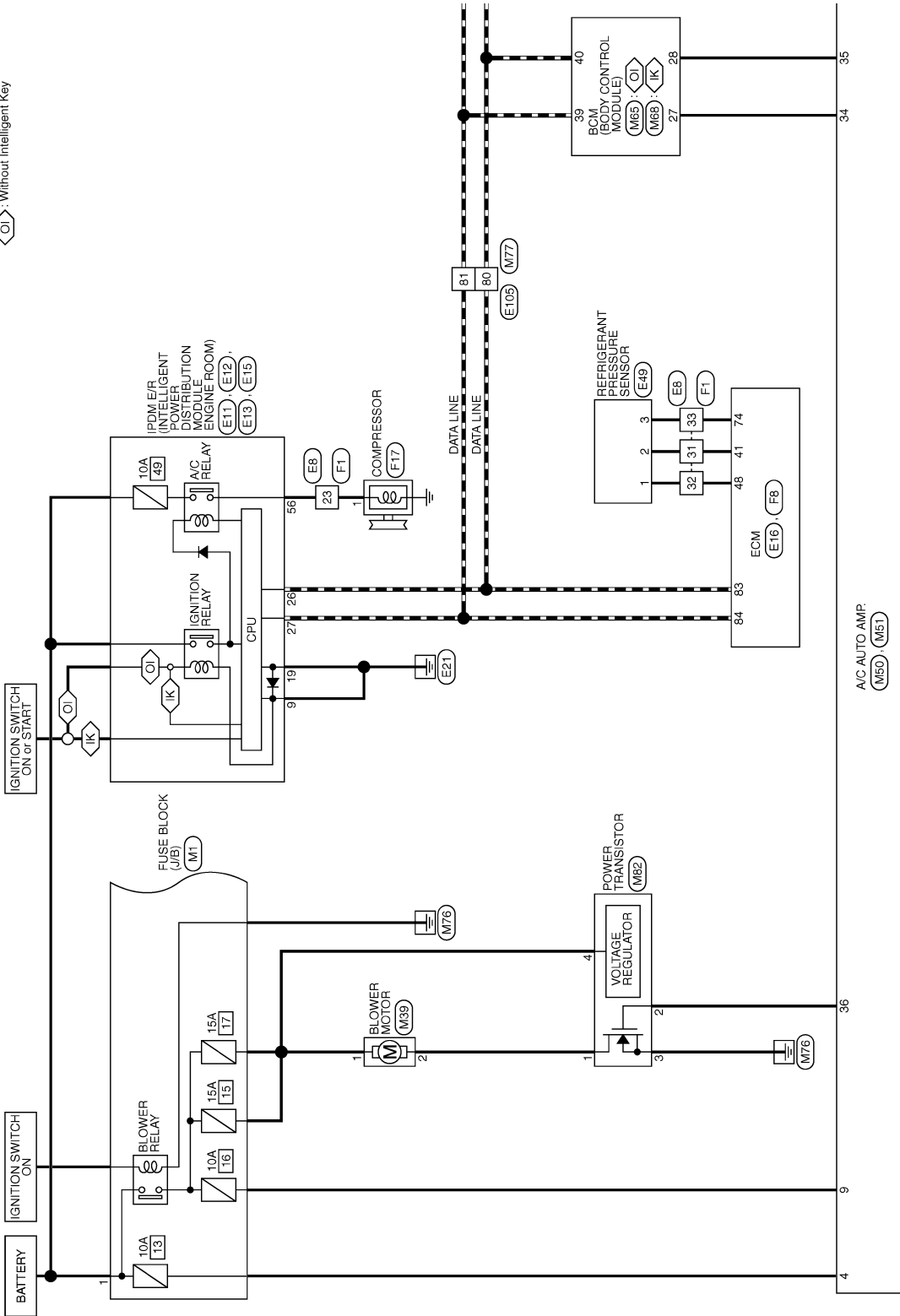

A/C AUTO AMP.  
(M50) (M51)

2009/10/02

JCIWM0607GB

# A/C AUTO AMP.

< ECU DIAGNOSIS INFORMATION >

[AUTOMATIC AIR CONDITIONING]

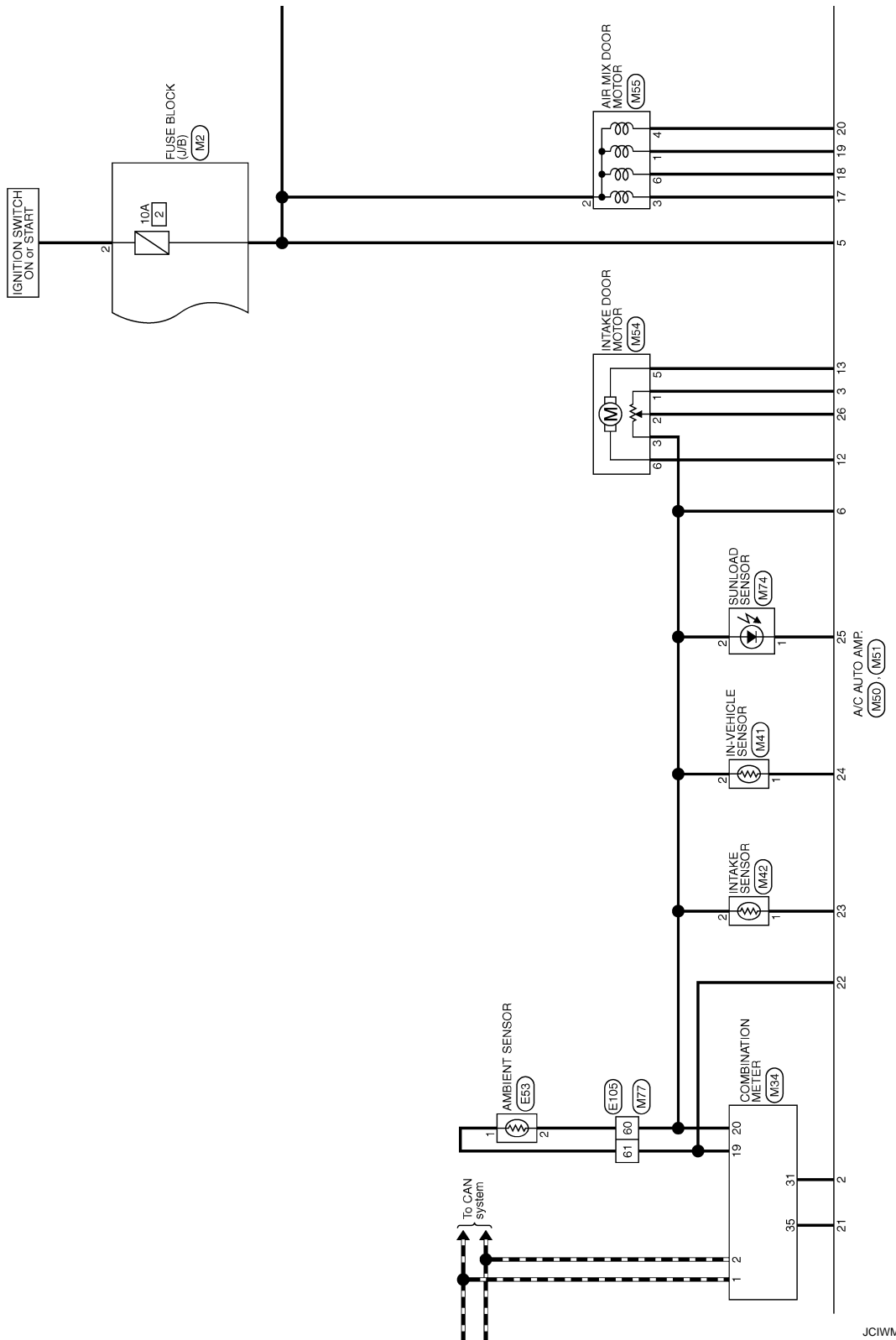

JCIWM0608GB

A  
B  
C  
D  
E  
F  
G  
H  
HAC  
J  
K  
L  
M  
N  
O  
P

# A/C AUTO AMP.

< ECU DIAGNOSIS INFORMATION >

[AUTOMATIC AIR CONDITIONING]

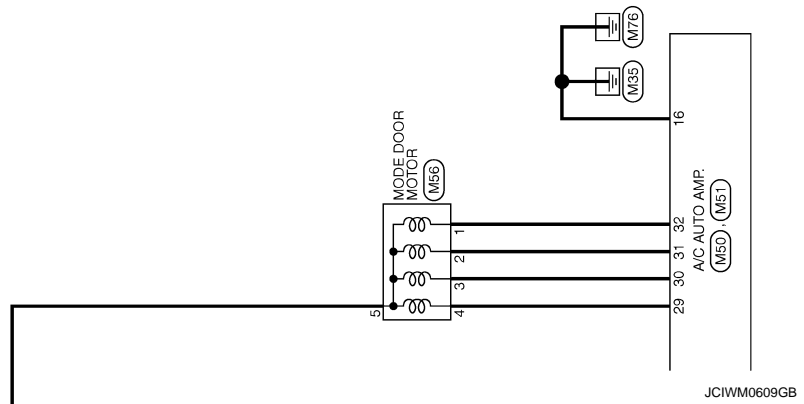

AUTOMATIC AIR CONDITIONING SYSTEM

Connector No.	E8
Connector Name	WIRE TO WIRE
Connector Type	SAC30MB-RS10-SJ22

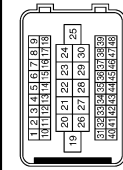

Connector No.	E11
Connector Name	SPM E/R INTELLIGENT POWER DISTRIBUTION MODULE (ENGINE ROOM)
Connector Type	MODFB-LC



11	10	9
14	13	12

Terminal No.	Color of Wire	Signal Name [Specification]
9	B/W	
10	L	
13	W	

Connector No.	E12
Connector Name	SPM E/R INTELLIGENT POWER DISTRIBUTION MODULE (ENGINE ROOM)
Connector Type	NSD0FER-CS



17	16	15
22	21	20
19	18	18

Terminal No.	Color of Wire	Signal Name [Specification]
18	Y	
19	B/W	
21	W	
22	V	

Connector No.	E13
Connector Name	SPM E/R INTELLIGENT POWER DISTRIBUTION MODULE (ENGINE ROOM)
Connector Type	TH12FN-NH



28	27	26	25	24	23
34	33	32	31	30	29

Terminal No.	Color of Wire	Signal Name [Specification]
24	LG	
25	Y	
26	P	
27	L	
28	P	
30	SB	
31	W	
33	O	
34	R	

Connector No.	E15
Connector Name	SPM E/R INTELLIGENT POWER DISTRIBUTION MODULE (ENGINE ROOM)
Connector Type	NS18FW-CS



53	52	51	50	49	48	47
62	61	60	59	58	57	56
55	54	53	52	51	50	49

Terminal No.	Color of Wire	Signal Name [Specification]
47	BR	
49	W	
50	GR	
51	R	
52	P	
54	GR	
55	P	
56	SB	
57	G	
58	R	- [With CVT]
59	Y	- [With M/T]
60	V	

61	W
62	L



Connector No.	E16
Connector Name	ECM
Connector Type	RH24FB-R23-L-RH

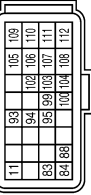

Terminal No.	Color of Wire	Signal Name [Specification]
83	P	CAN-L
84	L	CAN-H
88	LG	K LINE
93	L	IGNSW
94	SB	ASCDSW
95	BR	GND-ASCDSW
99	W	BRAKE
100	SB	BNGSW
102	O	AVCC-APSZ
103	G	APSZ
104	R	GND-APSZ
105	G	VBR
106	V	AVCC-APSI
108	B	GND
110	BR	APSI
111	Y	GND-APSI

A  
B  
C  
D  
E  
F  
G  
H  
HAC  
J  
K  
L  
M  
N  
O  
P

AUTOMATIC AIR CONDITIONING SYSTEM

Connector No.	E49
Connector Name	REFRIGERANT PRESSURE SENSOR
Connector Type	RK03FB



Terminal No.	Color of Wire	Signal Name [Specification]
1	O	-
2	G	-
3	W	-

Connector No.	E53
Connector Name	AMBIENT SENSOR
Connector Type	RS02FB



Terminal No.	Color of Wire	Signal Name [Specification]
1	G	AMBIENT SENSOR SIGNAL
2	O	SENSOR GROUND

Connector No.	E105
Connector Name	WIRE TO WIRE
Connector Type	TH80MW-CS16-TM4

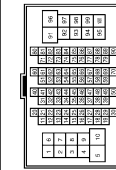

Terminal No.	Color of Wire	Signal Name [Specification]
1	V	-

2	W	-
3	SR	-
4	G	-
5	P	-
6	R	-
7	Y	-
8	O	-
9	W	-
10	SB	-
31	V	-
32	R	-
33	GR	-
34	P	-
35	Y	-
36	BR	-
39	SR	-
44	R	-
45	V	-
46	P	-
47	W	-
48	L	-
49	Y	-
50	W	-
51	BR	- [With. OVT]
51	B	- [With. M/T]
53	SB	-
54	W	- [With. OVT]
54	O	- [With. M/T]
57	LG	-
59	L	-
60	O	-
61	G	-
62	W	-
63	L	-
67	GR	- [With. OVT]
67	V	- [With. M/T]
69	P	-
70	SHIELD	-
71	GR	-
72	LG	-
73	P	-
74	V	-
76	Y	-
77	LG	-
78	O	-
79	G	-
80	P	-
81	L	-
82	W	-
83	BR	-
84	B	-
87	GR	-

32	BR	-
33	W	-
34	LG	-
35	V	-
36	Y	-
37	W	-
39	G	-
40	P	-
41	O	-
42	G	-
43	R	-
44	P	-
46	GR	-
47	Y	-
48	BR	-

91	W	-
92	Y	-
93	Y	-
94	R	-
95	V	-
96	LG	-
97	R	-
98	SB	-
99	G	-
100	P	-

Connector No.	F1
Connector Name	WIRE TO WIRE
Connector Type	SAA38FB-RS10F-SJZZ



Terminal No.	Color of Wire	Signal Name [Specification]
1	SB	-
2	LG	-
3	R	-
4	Y	-
7	V	-
8	G	-
9	SB	-
10	L	-
11	V	-
12	GR	-
13	BR	-
14	G	-
15	W	-
16	Y	-
17	P	-
18	BR	-
21	G	-
23	W	-
24	R	-
25	R	-
26	B	-
27	SB	-
28	V	-
29	V	-
30	BR	-
31	GR	-

AUTOMATIC AIR CONDITIONING SYSTEM

Connector No.	F8
Connector Name	ECM
Connector Type	RH40FB-R28-L-RH

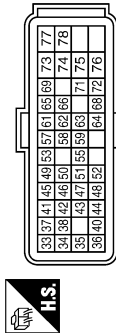

Terminal No.	Color of Wire	Signal Name [Specification]
33	LG	TFS 1
34	R	TFS 2
36	Y	GND-A-TFS
37	W	TW
38	BR	GND-A-K/K
40	SHIELD	PDPRES
41	GR	FTPRES
42	V	TF
43	P	GND-A-TW
44	GR	QA+
45	G	TA
46	L	GND-A-PDPRES
48	BR	AF+
49	V	OZSR
50	W	GND-A-FTPRES
51	Y	QA-
52	R	AF-
53	LG	GND-A-TA
55	P	CURSEN
58	GR	GND-A-OZSR
59	O	POS
61	W	GND-POS
62	R	GND-PHASE
63	BR	PHASE
65	G	GND-CURSEN
68	SB	NEUT-H
69	L	AVCC-TFS
72	O	GVTC
73	P	AVCC-PDPRES
74	W	AVCC-POS
75	BR	AVCC-FTPRES
76	LG	AVCC-CURSEN
77	Y	AVCC-PHASE
78	O	

Connector No.	F17
Connector Name	COMPRESSOR
Connector Type	RS07FB



Terminal No.	1	W	MAGNET GLUTCH POWER SUPPLY
--------------	---	---	----------------------------

Connector No.	M1
Connector Name	FUSE BLOCK (J/B)
Connector Type	-



Terminal No.	1	W	-
--------------	---	---	---

Connector No.	M2
Connector Name	FUSE BLOCK (J/B)
Connector Type	-



Terminal No.	2	W/R	Signal Name [Specification] - [With Intelligent Key] - [Without Intelligent Key]
--------------	---	-----	--

Connector No.	M34
Connector Name	COMBINATION METER
Connector Type	TH40FW-NH

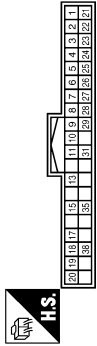

Terminal No.	Color of Wire	Signal Name [Specification]
1	L	CAN-H
2	P	CAN-L
3	V	VEHICLE SPEED SIGNAL (2-PULSE)
4	L	VEHICLE SPEED SIGNAL (8-PULSE)
6	BR/Y	FUEL LEVEL SENSOR SIGNAL
7	R/G	AIR BAG SIGNAL
8	P	OVERDRIVE CONTROL SWITCH SIGNAL
9	O	SEAT BELT BUCKLE SWITCH SIGNAL (DRIVER SIDE)
10	SB	PARKING BRAKE SWITCH SIGNAL
11	G/R	BRAKE FLUID LEVEL SWITCH SIGNAL
13	B/R	ILLUMINATION CONTROL SIGNAL
15	L/Y	ACC POWER SUPPLY
17	G	WASHER LEVEL SWITCH SIGNAL
18	R/Y	SECURITY SIGNAL
19	V/W	AMBIENT SENSOR SIGNAL
20	R/W	AMBIENT SENSOR GROUND
21	B	GROUND
22	B	GROUND
23	B	GROUND
24	V	FUEL LEVEL SENSOR GROUND
25	B	VDC GROUND
27	LG	BATTERY POWER SUPPLY
28	GR	IGNITION SIGNAL
29	BR	PASSENGER SEAT BELT WARNING SIGNAL
31	R	A/C AUTO AMP CONNECTION RECOGNITION SIGNAL
35	BR	ENGINE COOLANT TEMPERATURE SIGNAL
38	GR	ALTERNATOR SIGNAL

Connector No.	M39
Connector Name	BLOWER MOTOR
Connector Type	TM02FW

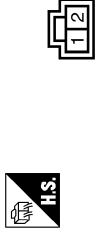

Terminal No.	1	Y	Signal Name [Specification] BLOWER MOTOR POWER SUPPLY
2	R	BLOWER MOTOR CONTROL SIGNAL [With auto A/C]	
2	L	SENSOR GROUND [Except with auto A/C]	

Connector No.	M41
Connector Name	IN-VEHICLE SENSOR
Connector Type	A02FW



Terminal No.	1	G	Signal Name [Specification] IN-VEHICLE SENSOR SIGNAL
2	R/W	SENSOR GROUND	

A  
B  
C  
D  
E  
F  
G  
H  
HAC  
J  
K  
L  
M  
N  
O  
P

AUTOMATIC AIR CONDITIONING SYSTEM

Connector No.	M42
Connector Name	INTAKE SENSOR
Connector Type	TK20FB



Terminal No.	Color of Wire	Signal Name [Specification]
1	O	INTAKE SENSOR SIGNAL
2	R/W	SENSOR GROUND

Connector No.	M50
Connector Name	A/C AUTO AMP.
Connector Type	TK20FG

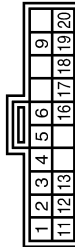

Terminal No.	Color of Wire	Signal Name [Specification]
1	W	ILLUMINATION POWER SUPPLY
2	R	A/C AUTO AMP. CONNECTION RECOGNITION SIGNAL
3	R	INTAKE DOOR MOTOR PBR POWER SUPPLY
4	LG	BATTERY POWER SUPPLY
5	O	IGNITION POWER SUPPLY
6	R/W	SENSOR GROUND
7	Y	IGNITION POWER SUPPLY
11	B/R	ILLUMINATION GROUND
12	L	FRE DRIVE SIGNAL
13	G	REC DRIVE SIGNAL
16	B	GROUND
17	BR	A/MIX DRIVE SIGNAL 4
18	SB	A/MIX DRIVE SIGNAL 3
19	GR	A/MIX DRIVE SIGNAL 2
20	P	A/MIX DRIVE SIGNAL 1

Connector No.	M51
Connector Name	A/C AUTO AMP.
Connector Type	TK18FGY



Terminal No.	Color of Wire	Signal Name [Specification]
21	BR	WATER TEMPERATURE SIGNAL
22	V/W	AMBIENT SENSOR SIGNAL
23	O	INTAKE SENSOR SIGNAL
24	G	IN-VEHICLE SENSOR SIGNAL
25	P	SUNLOAD SENSOR SIGNAL
26	SB	INTAKE DOOR MOTOR PBR F/B SIGNAL
27	R	REAR WINDOW DEFOGGER F/B SIGNAL
29	GR	MODE DRIVE SIGNAL 4
30	W	MODE DRIVE SIGNAL 3
31	Y	MODE DRIVE SIGNAL 2
32	V	MODE DRIVE SIGNAL 1
33	W/L	REAR WINDOW DEFOGGER ON SIGNAL
34	Y/G	A/C ON SIGNAL
35	G/W	BLOWER FAN ON SIGNAL
36	GR/R	POWER TRANSISTOR CONTROL SIGNAL

Connector No.	M54
Connector Name	INTAKE DOOR MOTOR
Connector Type	381193-0001



Terminal No.	Color of Wire	Signal Name [Specification]
1	R	INTAKE DOOR MOTOR PBR POWER SUPPLY
2	SB	INTAKE DOOR MOTOR PBR F/B SIGNAL (With auto A/C)
3	G	INTAKE DOOR MOTOR PBR F/B SIGNAL (E-accept, with auto A/C)
5	R/W	GROUND
6	L	REC DRIVE SIGNAL
	L	FRE DRIVE SIGNAL

Connector No.	M55
Connector Name	AIR MIX DOOR MOTOR
Connector Type	MAA08FB



Terminal No.	Color of Wire	Signal Name [Specification]
1	GR	A/MIX DRIVE SIGNAL 2
2	O	IGNITION POWER SUPPLY
3	BR	A/MIX DRIVE SIGNAL 4
4	P	A/MIX DRIVE SIGNAL 1
6	SB	A/MIX DRIVE SIGNAL 3

Connector No.	M56
Connector Name	MODE DOOR MOTOR
Connector Type	TH08FW-NH

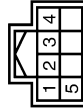

Terminal No.	Color of Wire	Signal Name [Specification]
1	V	MODE DRIVE SIGNAL 1
2	V	MODE DRIVE SIGNAL 2
3	W	MODE DRIVE SIGNAL 3
4	GR	MODE DRIVE SIGNAL 4
5	O	IGNITION POWER SUPPLY

Connector No.	M65
Connector Name	BCM (BODY CONTROL MODULE)
Connector Type	TH40FW-NH



Terminal No.	Color of Wire	Signal Name [Specification]
2	BR/W	COMBI SW INPUT 5
3	GR	COMBI SW INPUT 4
4	L/Y	COMBI SW INPUT 3
5	G	COMBI SW INPUT 2
6	L/R	COMBI SW INPUT 1
7	W/R	KEY CYL UNLOCK SW
8	W/B	KEY CYL LOCK SW
9	R	STOP LAMP SW
10	W/L	REAR WINDOW DEFOGGER SW
11	L/Y	ACC
12	SB	PASSENGER DOOR SW
13	GR/L	OPTICAL SENSOR
14	L/B	OPTICAL SENSOR
15	V/W	TIRE PRESS WARNING CHECK SW
17	R/G	REAR RH DOOR SW
18	V	OPTICAL SENSOR POWER SUPPLY
19	BR	KEYLESS ENTRY RECEIVER POWER SUPPLY
20	G/Y	KEYLESS ENTRY RECEIVER COMM
21	P/L	NAIS ANTENNA AMP
23	R/Y	SECURITY INDICATOR LAMP
24	GR/R	DONGLE LINK
25	LG	NAIS ANTENNA AMP
26	GR	THERMO CONTROL AMP
27	Y/G	A/C SW (With auto A/C)
28	V/R	A/C SW (With manual A/C)
29	G/W	BLOWER FAN SW
29	L/W	HAZARD SW
31	G/Y	FR DEFROSTER SW
32	LG	COMBI SW OUTPUT 5
33	Y/L	COMBI SW OUTPUT 4
34	W	COMBI SW OUTPUT 3
35	R/L	COMBI SW OUTPUT 2
36	L/O	COMBI SW OUTPUT 1
37	R/W	KEY SWITCH
38	O	IGN
39	L	CAN-H
40	P	CAN-L



A  
B  
C  
D  
E  
F  
G  
H  
HAC  
J  
K  
L  
M  
N  
O  
P

AUTOMATIC AIR CONDITIONING SYSTEM

Connector No.	IM68
Connector Name	BCM (BODY CONTROL MODULE)
Connector Type	TH40FB-NH

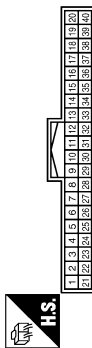

Terminal No.	Color of Wire	Signal Name [Specification]
2	BR/W	COMBI SW INPUT 5
3	GR	COMBI SW INPUT 4
4	L/Y	COMBI SW INPUT 3
5	G	COMBI SW INPUT 2
6	L/R	COMBI SW INPUT 1
7	W/R	KEY CYL UNLOCK SW
8	W/B	KEY CTL LOCK SW
9	R	STOP LAMP SW 1
10	V/W	TIRE PRESS WARNING CHECK SW
11	L/Y	ACC F/B
12	SB	PASSENGER DOOR SW
13	GR/L	REAR RH DOOR SW
14	L/B	OPTICAL SENSOR
15	W/L	REAR WINDOW DEFOGGER SW
17	R/G	OPTICAL SENSOR POWER SUPPLY RECEIVER / SENSOR GND
18	V	KEYLESS ENTRY RECEIVER POWER SUPPLY
19	BR	KEYLESS ENTRY RECEIVER COMM
20	G/Y	KEYLESS ENTRY RECEIVER COMM
21	P/L	NATS ANTENNA AMP
22	W/G	KEYLESS ENTRY RECEIVER RSSI
23	R/Y	SECURITY INDICATOR LAMP
24	GR/R	DONGLE LINK
25	LG	NATS ANTENNA AMP
27	Y/R	A/C SW
28	G/W	BLOWER FAN SW
29	L/W	HAZARD SW
31	G/B	DR DOOR UNLOCK SENSOR
32	LG	COMBI SW OUTPUT 5
33	Y/L	COMBI SW OUTPUT 4
34	W	COMBI SW OUTPUT 3
35	R/L	COMBI SW OUTPUT 2
36	L/O	COMBI SW OUTPUT 1
37	G/O	SHIFT P
38	O	IGN F/B
39	L	CAN-H
40	P	CAN-L

Connector No.	M74
Connector Name	SUNLOAD SENSOR
Connector Type	A02FW



Terminal No.	Color of Wire	Signal Name [Specification]
1	P	SUNLOAD SENSOR SIGNAL
2	R/W	SENSOR GROUND

Connector No.	M77
Connector Name	WIRE TO WIRE
Connector Type	TH80FW-CS16-TM4

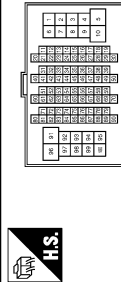

Terminal No.	Color of Wire	Signal Name [Specification]
1	B/O	
2	R	
3	G/R	
4	G/B	
5	L	
6	L	
7	W/R	
8	G/W	
9	Y/L	
10	W	
31	GR/L	
32	L/B	
33	R/Y	
34	SB	
35	BR	
36	G	
39	L/R	
44	G/O	
45	LG/R	
46	GR/W	

Connector No.	IM82
Connector Name	POWER TRANSISTOR
Connector Type	IM04FW-LC

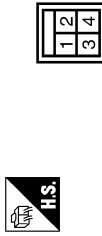

Terminal No.	Color of Wire	Signal Name [Specification]
1	R	BLOWER MOTOR CONTROL OUTPUT
2	GR/R	POWER TRANSISTOR CONTROL SIGNAL
3	B	GROUND
4	Y	IGNITION POWER SUPPLY

47	BR/Y	
48	L/O	
49	L/W	
50	P/L	
51	B/W	
53	R/L	
54	O	
57	GR	
59	V	
60	R/W	
61	V/W	
62	W/L	
63	W/B	
67	Y/R	
69	LG	
70	SHIELD	
71	P/B	
72	R/G	
74	R	
74	L/Y	
76	W/G	
77	GR/R	
78	O	
79	LG	
80	P	
81	L	
82	GR	
83	G/R	
84	B	
87	G	
91	R	
92	O	
93	Y	
94	R/B	
95	L/W	
96	Y	
97	L	
98	BR/W	
99	W	
100	G/R	

# BCM (BODY CONTROL MODULE)

< ECU DIAGNOSIS INFORMATION >

[AUTOMATIC AIR CONDITIONING]

## BCM (BODY CONTROL MODULE)

### BCM (BODY CONTROL SYSTEM) (WITH INTELLIGENT KEY SYSTEM)

### BCM (BODY CONTROL SYSTEM) (WITH INTELLIGENT KEY SYSTEM) : Reference Value

INFOID:000000005819854

#### VALUES ON THE DIAGNOSIS TOOL

##### CONSULT-III MONITOR ITEM

Monitor Item	Condition	Value/Status
FR WIPER HI	Other than front wiper switch HI	Off
	Front wiper switch HI	On
FR WIPER LOW	Other than front wiper switch LO	Off
	Front wiper switch LO	On
FR WASHER SW	Front washer switch OFF	Off
	Front washer switch ON	On
FR WIPER INT	Other than front wiper switch INT/AUTO	Off
	Front wiper switch INT/AUTO	On
FR WIPER STOP	Front wiper is not in STOP position	Off
	Front wiper is in STOP position	On
INT VOLUME	Wiper intermittent dial is in a dial position 1 - 7	Wiper intermittent dial position
RR WIPER ON	Other than rear wiper switch ON	Off
	Rear wiper switch ON	On
RR WIPER INT	Other than rear wiper switch INT	Off
	Rear wiper switch INT	On
RR WASHER SW	Rear washer switch OFF	Off
	Rear washer switch ON	On
RR WIPER STOP	Rear wiper is in STOP position	Off
	Rear wiper is not in STOP position	On
TURN SIGNAL R	Other than turn signal switch RH	Off
	Turn signal switch RH	On
TURN SIGNAL L	Other than turn signal switch LH	Off
	Turn signal switch LH	On
TAIL LAMP SW	Other than lighting switch 1ST and 2ND	Off
	Lighting switch 1ST or 2ND	On
HI BEAM SW	Other than lighting switch HI	Off
	Lighting switch HI	On
HEAD LAMP SW 1	Other than lighting switch 2ND	Off
	Lighting switch 2ND	On
HEAD LAMP SW 2	Other than lighting switch 2ND	Off
	Lighting switch 2ND	On
PASSING SW	Other than lighting switch PASS	Off
	Lighting switch PASS	On
AUTO LIGHT SW	Other than lighting switch AUTO	Off
	Lighting switch AUTO	On

# BCM (BODY CONTROL MODULE)

< ECU DIAGNOSIS INFORMATION >

[AUTOMATIC AIR CONDITIONING]

Monitor Item	Condition	Value/Status	
FR FOG SW	Front fog lamp switch OFF	Off	A
	Front fog lamp switch ON	On	
DOOR SW-DR	Driver door closed	Off	B
	Driver door opened	On	
DOOR SW-AS	Passenger door closed	Off	C
	Passenger door opened	On	
DOOR SW-RR	Rear RH door closed	Off	D
	Rear RH door opened	On	
DOOR SW-RL	Rear LH door closed	Off	E
	Rear LH door opened	On	
DOOR SW-BK	Back door closed	Off	F
	Back door opened	On	
CDL LOCK SW	Other than power door lock switch LOCK	Off	G
	Power door lock switch LOCK	On	
CDL UNLOCK SW	Other than power door lock switch UNLOCK	Off	H
	Power door lock switch UNLOCK	On	
KEY CYL LK-SW	Other than driver door key cylinder LOCK position	Off	I
	Driver door key cylinder LOCK position	On	
KEY CYL UN-SW	Other than driver door key cylinder UNLOCK position	Off	J
	Driver door key cylinder UNLOCK position	On	
HAZARD SW	Hazard switch is OFF	Off	HAC
	Hazard switch is ON	On	
REAR DEF SW	Rear window defogger switch OFF	Off	K
	Rear window defogger switch ON	On	
TR/BD OPEN SW	<b>NOTE:</b> The item is indicated, but not monitored.	Off	L
TRNK/HAT MNTR	<b>NOTE:</b> The item is indicated, but not monitored.	Off	M
FAN ON SIG	Blower fan OFF	Off	N
	Blower fan ON	On	
AIR COND SW	Air conditioner OFF (A/C switch indicator OFF)	Off	O
	Air conditioner ON (A/C switch indicator ON)	On	
RKE-LOCK	LOCK button of the key is not pressed	Off	P
	LOCK button of the key is pressed	On	
RKE-UNLOCK	UNLOCK button of the key is not pressed	Off	
	UNLOCK button of the key is pressed	On	
RKE-TR/BD	BACK DOOR OPEN button of the key is not pressed	Off	
	BACK DOOR OPEN button of the key is pressed	On	
RKE-PANIC	PANIC button of the key is not pressed	Off	
	PANIC button of the key is pressed	On	
RKE-MODE CHG	LOCK/UNLOCK button of the key is not pressed and held simultaneously	Off	
	LOCK/UNLOCK button of the key is pressed and held simultaneously	On	
OPTI SEN (DTCT)	Bright outside of the vehicle	Close to 5 V	
	Dark outside of the vehicle	Close to 0 V	

# BCM (BODY CONTROL MODULE)

< ECU DIAGNOSIS INFORMATION >

[AUTOMATIC AIR CONDITIONING]

Monitor Item	Condition	Value/Status
OPTI SEN (FILT)	Bright outside of the vehicle (Lighting switch AUTO)	Close to 5 V
	Dark outside of the vehicle (Lighting switch AUTO)	Close to 1.50 V
OPTICAL SENSOR	<b>NOTE:</b> The item is indicated, but not monitored.	Off
RAIN SENSOR	<b>NOTE:</b> The item is indicated, but not monitored.	Off
REQ SW -DR	Driver door request switch is not pressed	Off
	Driver door request switch is pressed	On
REQ SW -AS	Passenger door request switch is not pressed	Off
	Passenger door request switch is pressed	On
REQ SW -RR	<b>NOTE:</b> The item is indicated, but not monitored.	Off
REQ SW -RL	<b>NOTE:</b> The item is indicated, but not monitored.	Off
REQ SW -BD/TR	Back door request switch is not pressed	Off
	Back door request switch is pressed	On
PUSH SW	Push-button ignition switch (push switch) is not pressed	Off
	Push-button ignition switch (push switch) is pressed	On
CLUCH SW	<b>NOTE:</b> The item is indicated, but not monitored.	Off
BRAKE SW 1	The brake pedal is not depressed	Off
	The brake pedal is depressed	On
BRAKE SW 2	The brake pedal is depressed when No. 7 fuse is blown	Off
	The brake pedal is not depressed when No. 7 fuse is blown, or No. 7 fuse is normal	On
DETE/CANCL SW	Selector lever in P position	Off
	Selector lever in any position other than P	On
SFT PN/N SW	Selector lever in any position other than P and N	Off
	Selector lever in P or N position	On
S/L -LOCK	Steering is locked	Off
	Steering is unlocked	On
S/L -UNLOCK	Steering is unlocked	Off
	Steering is locked	On
S/L RELAY-F/B	Steering is unlocked	Off
	Steering is locked	On
UNLK SEN -DR	Driver door is locked	Off
	Driver door is unlocked	On
PUSH SW -IPDM	Push-button ignition switch (push-switch) is not pressed	Off
	Push-button ignition switch (push-switch) is pressed	On
IGN RLY1 -F/B	Ignition switch in OFF or ACC position	Off
	Ignition switch in ON position	On
DETE SW -IPDM	Selector lever in any position other than P	Off
	Selector lever in P position	On
SFT PN -IPDM	Selector lever in any position other than P and N	Off
	Selector lever in P or N position	On

## BCM (BODY CONTROL MODULE)

< ECU DIAGNOSIS INFORMATION >

[AUTOMATIC AIR CONDITIONING]

Monitor Item	Condition	Value/Status	
SFT P -MET	Selector lever in any position other than P	Off	A
	Selector lever in P position	On	
SFT N -MET	Selector lever in any position other than N	Off	B
	Selector lever in N position	On	
ENGINE STATE	Engine stopped	Stop	C
	While the engine stalls	Stall	
	At engine cranking	Crank	D
	Engine running	Run	
S/L LOCK-IPDM	Steering is locked	Off	E
	Steering is unlocked	On	
S/L UNLK-IPDM	Steering is unlocked	Off	F
	Steering is locked	On	
S/L RELAY-REQ	Steering is unlocked	Off	G
	Steering is locked	On	
VEH SPEED 1	While driving	Equivalent to speedometer reading	H
VEH SPEED 2	While driving	Equivalent to speedometer reading	
DOOR STAT-DR	Driver door is locked	LOCK	I
	Wait with selective UNLOCK operation (5 seconds)	READY	
	Driver door is unlocked	UNLOCK	HAC
DOOR STAT-AS	Passenger door is locked	LOCK	J
	Wait with selective UNLOCK operation (5 seconds)	READY	
	Passenger door is unlocked	UNLOCK	
ID OK FLAG	Steering is locked	Reset	K
	Steering is unlocked	Set	
PRMT ENG STRT	The engine start is prohibited	Reset	L
	The engine start is permitted	Set	
PRMT RKE STRT	<b>NOTE:</b> The item is indicated, but not monitored.	Reset	M
RKE OPE COUN1	During the operation of the key	Operation frequency of the key	
RKE OPE COUN2	<b>NOTE:</b> The item is indicated, but not monitored.	—	N
CONFIRM ID ALL	The key ID that the key slot receives is not recognized by any key ID registered to BCM.	Yet	O
	The key ID that the key slot receives is recognized by any key ID registered to BCM.	Done	
CONFIRM ID4	The key ID that the key slot receives is not recognized by the fourth key ID registered to BCM.	Yet	P
	The key ID that the key slot receives is recognized by the fourth key ID registered to BCM.	Done	
CONFIRM ID3	The key ID that the key slot receives is not recognized by the third key ID registered to BCM.	Yet	
	The key ID that the key slot receives is recognized by the third key ID registered to BCM.	Done	

## BCM (BODY CONTROL MODULE)

< ECU DIAGNOSIS INFORMATION >

[AUTOMATIC AIR CONDITIONING]

Monitor Item	Condition	Value/Status
CONFIRM ID2	The key ID that the key slot receives is not recognized by the second key ID registered to BCM.	Yet
	The key ID that the key slot receives is recognized by the second key ID registered to BCM.	Done
CONFIRM ID1	The key ID that the key slot receives is not recognized by the first key ID registered to BCM.	Yet
	The key ID that the key slot receives is recognized by the first key ID registered to BCM.	Done
NOT REGISTERED	BCM detects registered key ID, or BCM does not detect key ID.	ID OK
	BCM detects non-registration key ID.	ID NG
TP 4	The ID of fourth key is not registered to BCM	Yet
	The ID of fourth key is registered to BCM	Done
TP 3	The ID of third key is not registered to BCM	Yet
	The ID of third key is registered to BCM	Done
TP 2	The ID of second key is not registered to BCM	Yet
	The ID of second key is registered to BCM	Done
TP 1	The ID of first key is not registered to BCM	Yet
	The ID of first key is registered to BCM	Done
AIR PRESS FL	Ignition switch ON (Only when the signal from the transmitter is received)	Air pressure of front LH tire
AIR PRESS FR	Ignition switch ON (Only when the signal from the transmitter is received)	Air pressure of front RH tire
AIR PRESS RR	Ignition switch ON (Only when the signal from the transmitter is received)	Air pressure of rear RH tire
AIR PRESS RL	Ignition switch ON (Only when the signal from the transmitter is received)	Air pressure of rear LH tire
ID REGST FL1	ID of front LH tire transmitter is registered	Done
	ID of front LH tire transmitter is not registered	Yet
ID REGST FR1	ID of front RH tire transmitter is registered	Done
	ID of front RH tire transmitter is not registered	Yet
ID REGST RR1	ID of rear RH tire transmitter is registered	Done
	ID of rear RH tire transmitter is not registered	Yet
ID REGST RL1	ID of rear LH tire transmitter is registered	Done
	ID of rear LH tire transmitter is not registered	Yet
WARNING LAMP	Tire pressure indicator OFF	Off
	Tire pressure indicator ON	On
BUZZER	Tire pressure warning alarm is not sounding	Off
	Tire pressure warning alarm is sounding	On

# BCM (BODY CONTROL MODULE)

< ECU DIAGNOSIS INFORMATION >

[AUTOMATIC AIR CONDITIONING]

## TERMINAL LAYOUT

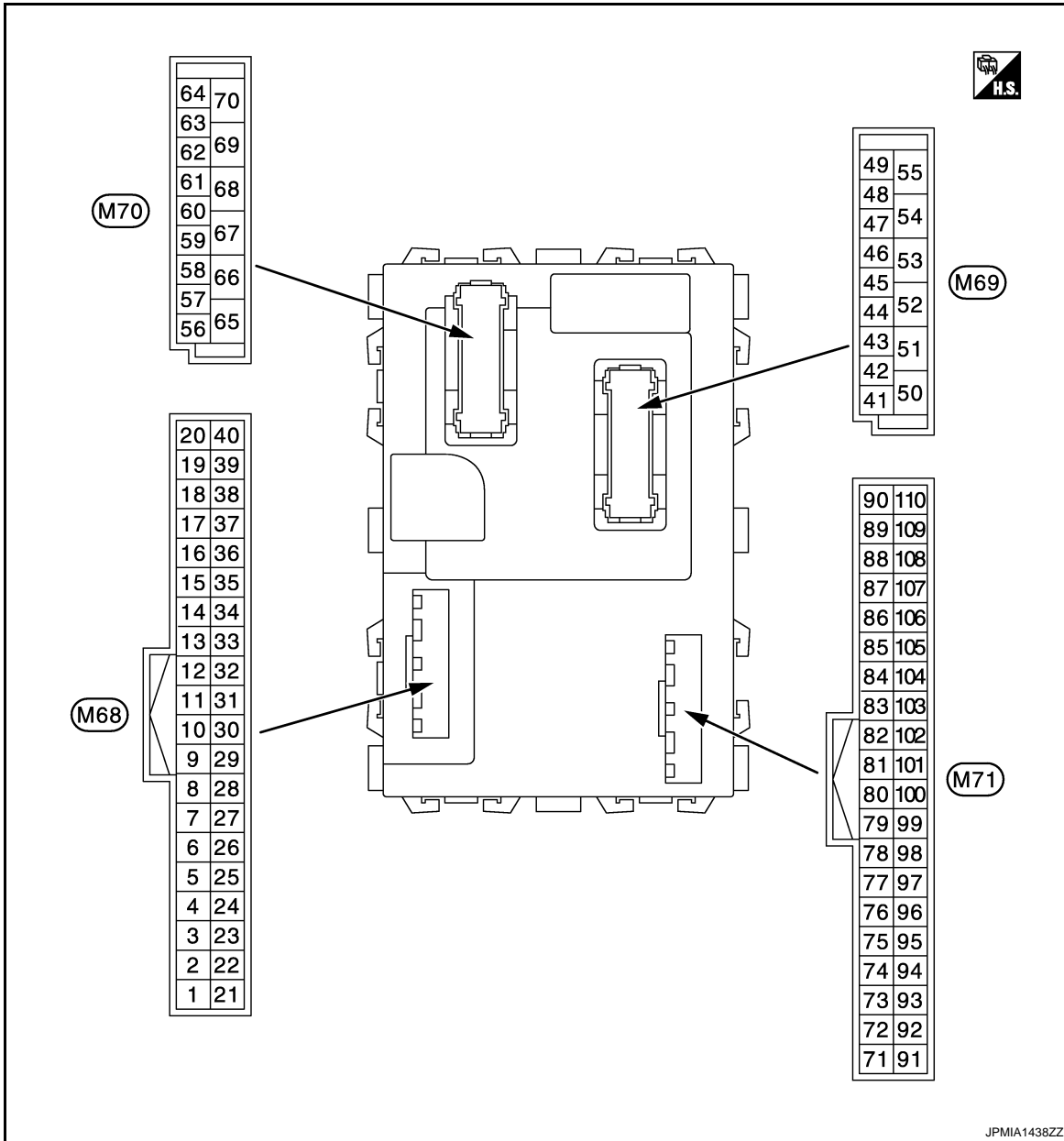

**NOTE:**

- Connector color
- M68, M70: Black
- M69, M71: White

**PHYSICAL VALUES**

A  
B  
C  
D  
E  
F  
G  
H  
HAC  
J  
K  
L  
M  
N  
O  
P

# BCM (BODY CONTROL MODULE)

< ECU DIAGNOSIS INFORMATION >

[AUTOMATIC AIR CONDITIONING]

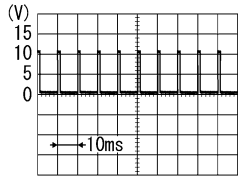
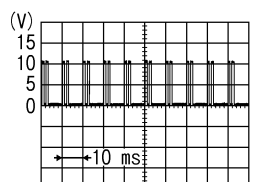
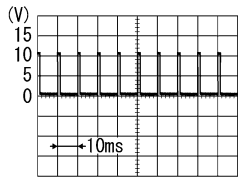
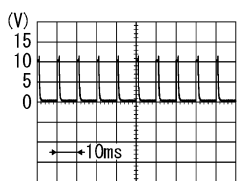
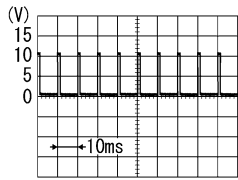
Terminal No. (Wire color)		Description		Condition	Value (Approx.)
+	-	Signal name	Input/ Output		
2 (BR/W)	Ground	Combination switch INPUT 5	Input	All switch OFF	0 V
				Turn signal switch RH	 <p style="text-align: right; font-size: small;">PKIB4958J</p>
				Lighting switch HI	
				Lighting switch 1ST	
				Lighting switch 2ND	 <p style="text-align: right; font-size: small;">JPMIA0342JP</p>
3 (GR)	Ground	Combination switch INPUT 4	Input	All switch OFF	0 V
				Turn signal switch LH	 <p style="text-align: right; font-size: small;">PKIB4958J</p>
				Lighting switch PASS	
				Lighting switch 2ND	
				Front fog lamp switch ON	 <p style="text-align: right; font-size: small;">PKIB4956J</p>
4 (L/Y)	Ground	Combination switch INPUT 3	Input	All switch OFF	0 V
				Front wiper switch LO	 <p style="text-align: right; font-size: small;">PKIB4958J</p>
				Front wiper switch MIST	
				Front wiper switch INT	
				Lighting switch AUTO	



# BCM (BODY CONTROL MODULE)

< ECU DIAGNOSIS INFORMATION >

[AUTOMATIC AIR CONDITIONING]

Terminal No. (Wire color)		Description		Condition	Value (Approx.)		
+	-	Signal name	Input/ Output				
5 (G)	Ground	Combination switch INPUT 2	Input	Combination switch	All switch OFF (Wiper intermittent dial 4)	0 V	
					Front washer switch (Wiper intermittent dial 4)		
					Rear washer ON (Wiper intermittent dial 4)		
					Any of the condition below with all switch OFF <ul style="list-style-type: none"> <li>• Wiper intermittent dial 1</li> <li>• Wiper intermittent dial 5</li> <li>• Wiper intermittent dial 6</li> </ul>		1.0 V
					Rear wiper switch ON (Wiper intermittent dial 4)		0.8 V
6 (L/R)	Ground	Combination switch INPUT 1	Input	Combination switch	All switch OFF (Wiper intermittent dial 4)	0 V	
					Front wiper switch HI (Wiper intermittent dial 4)		
					Rear wiper switch INT (Wiper intermittent dial 4)		
					Wiper intermittent dial 3 (All switch OFF)		1.0 V
					Any of the condition below with all switch OFF <ul style="list-style-type: none"> <li>• Wiper intermittent dial 1</li> <li>• Wiper intermittent dial 2</li> </ul>		1.9 V
					Any of the condition below with all switch OFF <ul style="list-style-type: none"> <li>• Wiper intermittent dial 6</li> <li>• Wiper intermittent dial 7</li> </ul>		0.8 V

A  
B  
C  
D  
E  
F  
G  
H  
HAC  
J  
K  
L  
M  
N  
O  
P

# BCM (BODY CONTROL MODULE)

< ECU DIAGNOSIS INFORMATION >

[AUTOMATIC AIR CONDITIONING]

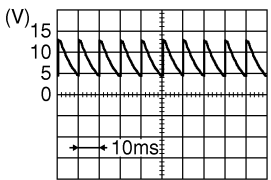
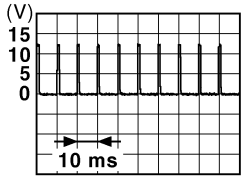
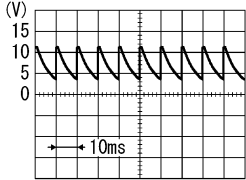
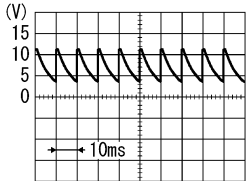
Terminal No. (Wire color)		Description		Condition	Value (Approx.)	
+	-	Signal name	Input/ Output			
7 (W/R)	Ground	Door key cylinder switch UNLOCK	Input	Door key cylin- der switch	NEUTRAL position	 <p style="text-align: right; font-size: small;">JPMIA0587GB</p>
				UNLOCK position	0 V	
8 (W/B)	Ground	Door key cylinder switch LOCK	Input	Door key cylin- der switch	NEUTRAL position	12 V
				LOCK position	0 V	
9 (R)	Ground	Stop lamp switch 1	Input	Stop lamp switch	OFF (Brake pedal is not depressed)	0 V
					ON (Brake pedal is de- pressed)	Battery voltage
10 (V/W)	Ground	Tire pressure warn- ing check switch	Input	Ignition switch OFF	Ignition switch OFF	 <p style="text-align: right; font-size: small;">JPMIA0012GB</p>
					Ignition switch ACC or ON	Battery voltage
11 (L/Y)	Ground	ACC feedback	Input	Ignition switch OFF	0 V	
				Ignition switch ACC or ON	Battery voltage	
12 (SB)	Ground	Passenger door switch	Input	Passenger door switch	OFF (When passenger door closed)	 <p style="text-align: right; font-size: small;">PKIB4960J</p>
					ON (When passenger door opened)	0 V
13 (GR/L)	Ground	Rear RH door switch	Input	Rear RH door switch	OFF (When rear RH door closed)	 <p style="text-align: right; font-size: small;">PKIB4960J</p>
					ON (When rear RH door opened)	0 V
14 (L/B)	Ground	Optical sensor	Input	Ignition switch ON	When bright outside of the vehicle	Close to 5 V
					When dark outside of the vehicle	Close to 0 V

# BCM (BODY CONTROL MODULE)

< ECU DIAGNOSIS INFORMATION >

[AUTOMATIC AIR CONDITIONING]

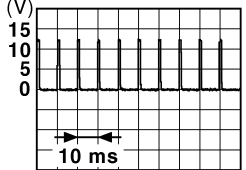
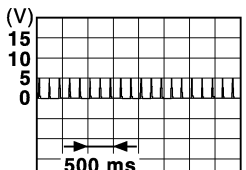
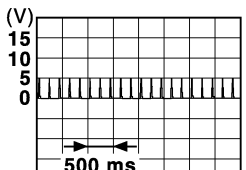
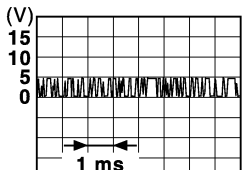
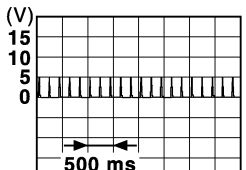
Terminal No. (Wire color)		Description		Condition		Value (Approx.)
+	-	Signal name	Input/ Output			
15 (W/L)	Ground	Rear window defogger switch	Input	Rear window defogger switch	Not pressed	 <small>JPMIA0012GB</small> 1.0 - 1.5 V
				Rear window defogger switch	Pressed	0 V
17 (R/G)	Ground	Optical sensor power supply	Output	Ignition switch	OFF, ACC	0 V
					ON	5 V
18 (V)	Ground	Receiver and sensor ground	Input	Ignition switch ON		0 V
19 (BR)	Ground	Remote keyless entry receiver power supply	Output	Ignition switch OFF		 <small>JMKIA3838GB</small>
20 (G/Y)	Ground	Remote keyless entry receiver communication	Input	Waiting	 <small>JMKIA3838GB</small>	
				Signal receiving	 <small>JMKIA3841GB</small>	
21 (P/L)	Ground	NATS antenna amp.	Input/ Output	During waiting	Ignition switch is pressed while inserting the key into the key slot.	Just after pressing ignition switch. Pointer of tester should move.
22 (W/G)	Ground	Remote keyless entry receiver RSSI	Input	Waiting		0 V
				Signal receiving		 <small>JMKIA3838GB</small>

A  
B  
C  
D  
E  
F  
G  
H  
HAC  
J  
K  
L  
M  
N  
O  
P

# BCM (BODY CONTROL MODULE)

< ECU DIAGNOSIS INFORMATION >

[AUTOMATIC AIR CONDITIONING]

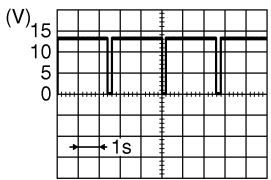
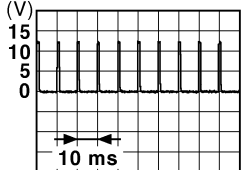
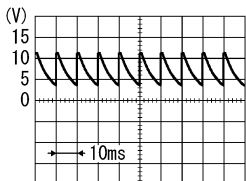
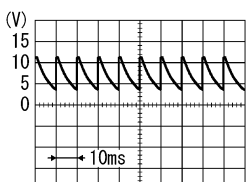
Terminal No. (Wire color)		Description		Condition	Value (Approx.)		
+	-	Signal name	Input/ Output				
23 (R/Y)	Ground	Security indicator lamp	Output	Security indicator	ON	0 V	
				Blinking (Ignition switch OFF)	 <p style="text-align: right; font-size: small;">JPMIA0590GB</p>	12.0 V	
				OFF	Battery voltage		
24* (GR/R)	Ground	Dongle link	Input/ Output	Ignition switch OFF		5 V	
25 (LG)	Ground	NATS antenna amp.	Input/ Output	During waiting	Ignition switch is pressed while inserting the key into the key slot.	Just after pressing ignition switch. Pointer of tester should move.	
27 (Y/G)	Ground	A/C switch	Input	Air conditioner	OFF (A/C switch indicator: OFF)	 <p style="text-align: right; font-size: small;">JPMIA0012GB</p>	1.0 - 1.5 V
				ON (A/C switch indicator: ON)	0 V		
28 (G/W)	Ground	Blower fan switch	Input	Blower fan	OFF	0 V	
				ON	 <p style="text-align: right; font-size: small;">PKIB4960J</p>	7.0 - 8.0 V	
29 (L/W)	Ground	Hazard switch	Input	Hazard switch	OFF	12 V	
				ON	0 V		
31 (G/B)	Ground	Front door lock assembly driver side (Unlock sensor)	Input	Driver door	LOCK status (Unlock sensor switch OFF)	 <p style="text-align: right; font-size: small;">PKIB4960J</p>	7.0 - 8.0 V
				UNLOCK status (Unlock sensor switch ON)	0 V		

# BCM (BODY CONTROL MODULE)

< ECU DIAGNOSIS INFORMATION >

[AUTOMATIC AIR CONDITIONING]

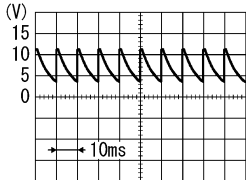
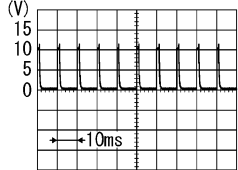
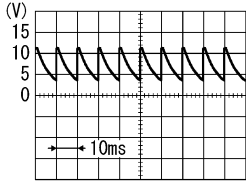
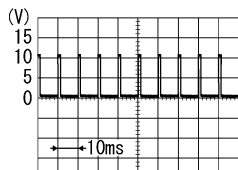
Terminal No. (Wire color)		Description		Condition	Value (Approx.)	
+	-	Signal name	Input/ Output			
32 (LG)	Ground	Combination switch OUTPUT 5	Output	Combination switch	All switch OFF (Wiper intermittent dial 4)	 <p style="text-align: right; font-size: small;">PKIB4960J</p> <p style="text-align: center;">7.0 - 8.0 V</p>
					Front fog lamp switch ON (Wiper intermittent dial 4)	 <p style="text-align: right; font-size: small;">PKIB4956J</p> <p style="text-align: center;">1.0 V</p>
					Rear wiper switch ON (Wiper intermittent dial 4)	
					Any of the condition below with all switch OFF <ul style="list-style-type: none"> <li>• Wiper intermittent dial 1</li> <li>• Wiper intermittent dial 2</li> <li>• Wiper intermittent dial 6</li> <li>• Wiper intermittent dial 7</li> </ul>	
33 (Y/L)	Ground	Combination switch OUTPUT 4	Output	Combination switch	All switch OFF (Wiper intermittent dial 4)	 <p style="text-align: right; font-size: small;">PKIB4960J</p> <p style="text-align: center;">7.0 - 8.0 V</p>
					Lighting switch 1ST (Wiper intermittent dial 4)	 <p style="text-align: right; font-size: small;">PKIB4958J</p> <p style="text-align: center;">1.2 V</p>
					Lighting switch AUTO (Wiper intermittent dial 4)	
					Rear wiper switch INT (Wiper intermittent dial 4)	
Any of the condition below with all switch OFF <ul style="list-style-type: none"> <li>• Wiper intermittent dial 1</li> <li>• Wiper intermittent dial 5</li> <li>• Wiper intermittent dial 6</li> </ul>						

A  
B  
C  
D  
E  
F  
G  
H  
I  
J  
K  
L  
M  
N  
O  
P

HAC

# BCM (BODY CONTROL MODULE)

< ECU DIAGNOSIS INFORMATION >

[AUTOMATIC AIR CONDITIONING]

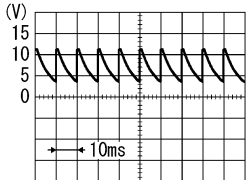
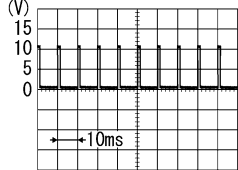
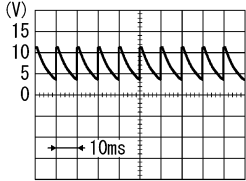
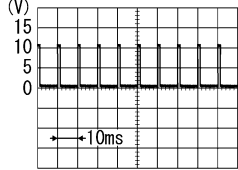
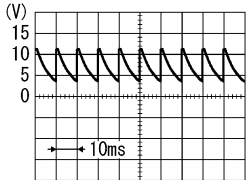
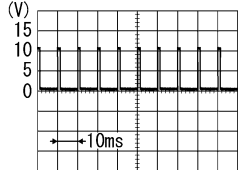
Terminal No. (Wire color)		Description		Condition	Value (Approx.)	
+	-	Signal name	Input/ Output			
34 (W)	Ground	Combination switch OUTPUT 3	Output	Combination switch	All switch OFF (Wiper intermittent dial 4)	 <p style="text-align: right; font-size: small;">PKIB4960J</p> <p style="text-align: center;">7.0 - 8.0 V</p>
					Lighting switch 2ND (Wiper intermittent dial 4)	 <p style="text-align: right; font-size: small;">PKIB4958J</p> <p style="text-align: center;">1.2 V</p>
					Lighting switch HI (Wiper intermittent dial 4)	
					Rear washer switch ON (Wiper intermittent dial 4)	
Any of the condition below with all switch OFF						
<ul style="list-style-type: none"> <li>• Wiper intermittent dial 1</li> <li>• Wiper intermittent dial 2</li> <li>• Wiper intermittent dial 3</li> </ul>						
35 (R/L)	Ground	Combination switch OUTPUT 2	Output	Combination switch (Wiper intermit- tent dial 4)	All switch OFF	 <p style="text-align: right; font-size: small;">PKIB4960J</p> <p style="text-align: center;">7.0 - 8.0 V</p>
					Lighting switch 2ND	 <p style="text-align: right; font-size: small;">PKIB4958J</p> <p style="text-align: center;">1.2 V</p>
					Lighting switch PASS	
					Front wiper switch INT	
Front wiper switch HI						
36 (L/O)	Ground	Combination switch OUTPUT 1	Output	Combination switch (Wiper intermit- tent dial 4)	All switch OFF	 <p style="text-align: right; font-size: small;">PKIB4960J</p> <p style="text-align: center;">7.0 - 8.0 V</p>
					Turn signal switch RH	 <p style="text-align: right; font-size: small;">PKIB4958J</p> <p style="text-align: center;">1.2 V</p>
					Turn signal switch LH	
					Front wiper switch LO (Front wiper switch MIST)	
Front washer switch ON						

# BCM (BODY CONTROL MODULE)

< ECU DIAGNOSIS INFORMATION >

[AUTOMATIC AIR CONDITIONING]

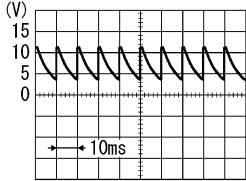
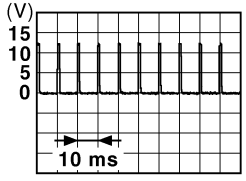
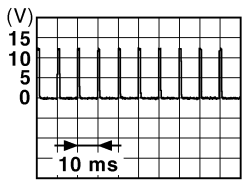
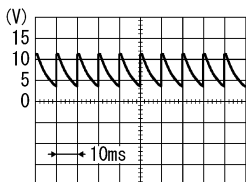
Terminal No. (Wire color)		Description		Condition		Value (Approx.)
		Signal name	Input/ Output			
+	-					
37 (G/O)	Ground	Selector lever P position switch	Input	Selector lever	P position	0 V
					Any position other than P	12 V
38 (O)	Ground	IGN feedback	Input	Ignition switch	OFF or ACC	0 V
					ON	Battery voltage
39 (L)	Ground	CAN-H	Input/ Output	—	—	
40 (P)	Ground	CAN-L	Input/ Output	—	—	
43 (W)	Ground	Back door switch	Input	Back door switch	OFF (When back door closed)	 <p style="text-align: right; font-size: small;">PKIB4960J</p> <p style="text-align: center;">9.5 - 10.0 V</p>
					ON (When back door opened)	0 V
44 (LG)	Ground	Rear wiper stop position	Input	Ignition switch ON	Rear wiper stop position	12 V
					Any position other than rear wiper stop position	0 V
45 (GR)	Ground	Door lock and unlock switch LOCK	Input	Door lock and unlock switch	NEUTRAL position	 <p style="text-align: right; font-size: small;">JPMIA0012GB</p> <p style="text-align: center;">1.0 - 1.5 V</p>
					LOCK position	0 V
46 (BR)	Ground	Door lock and unlock switch UNLOCK	Input	Door lock and unlock switch	NEUTRAL position	 <p style="text-align: right; font-size: small;">JPMIA0012GB</p> <p style="text-align: center;">1.0 - 1.5 V</p>
					UNLOCK position	0 V
47 (BR/Y)	Ground	Driver door switch	Input	Driver door switch	OFF (When driver door closed)	 <p style="text-align: right; font-size: small;">PKIB4960J</p> <p style="text-align: center;">7.0 - 8.0 V</p>
					ON (When driver door opened)	0 V

A  
B  
C  
D  
E  
F  
G  
H  
I  
J  
K  
L  
M  
N  
O  
P

HAC

# BCM (BODY CONTROL MODULE)

< ECU DIAGNOSIS INFORMATION >

[AUTOMATIC AIR CONDITIONING]

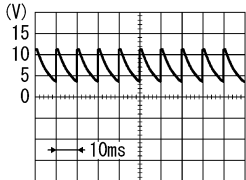
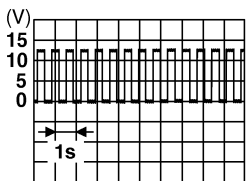
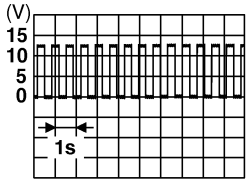
Terminal No. (Wire color)		Description		Condition		Value (Approx.)
+	-	Signal name	Input/ Output			
48 (W/G)	Ground	Rear LH door switch	Input	Rear LH door switch	OFF (When rear LH door closed)	 <small>PKIB4960J</small> 7.0 - 8.0 V
					ON (When rear door LH opened)	0 V
54 (L/W)	Ground	Rear wiper	Output	Rear wiper	OFF (Stopped)	0 V
					ON (Activated)	12 V
55 (G)	Ground	Rear door UNLOCK	Output	Rear door	UNLOCK (Actuator is activated)	12 V
					Other then UNLOCK (Actuator is not activated)	0 V
56 (L)	Ground	Interior room lamp power supply	Output	Interior room lamp battery saver is activated. (Cuts the interior room lamp power supply)	0 V	
				Interior room lamp battery saver is not activated. (Outputs the interior room lamp power supply)	12 V	
57 (Y)	Ground	Battery power supply	Input	Ignition switch OFF	Battery voltage	
59 (G)	Ground	Passenger door UNLOCK	Output	Passenger door	UNLOCK (Actuator is activated)	12 V
					Other then UNLOCK (Actuator is not activated)	0 V
60 (W/B)	Ground	Turn signal LH	Output	Ignition switch ON	Turn signal switch OFF	0 V
					Turn signal switch LH	 <small>PKIC6370E</small> 6.0 V
61 (W/L)	Ground	Turn signal RH	Output	Ignition switch ON	Turn signal switch OFF	0 V
					Turn signal switch RH	 <small>PKIC6370E</small> 6.0 V
63 (BR)	Ground	Interior room lamp timer control	Output	Interior room lamp	OFF	12 V
					ON	0 V



# BCM (BODY CONTROL MODULE)

< ECU DIAGNOSIS INFORMATION >

[AUTOMATIC AIR CONDITIONING]

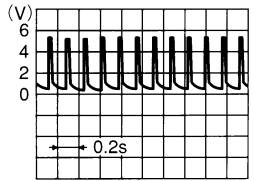
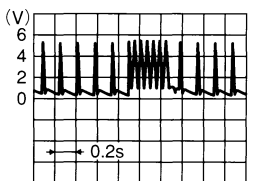
Terminal No. (Wire color)		Description		Condition		Value (Approx.)
		Signal name	Input/ Output			
+	-					
65 (V)	Ground	All doors LOCK	Output	All doors	LOCK (Actuator is activated)	12 V
					Other than LOCK (Actuator is not activated)	0 V
66 (L/B)	Ground	Driver door UNLOCK	Output	Driver door	UNLOCK (Actuator is activated)	12 V
					Other than UNLOCK (Actuator is not activated)	0 V
67 (B)	Ground	Ground	Output	Ignition switch ON		0 V
68 (L)	Ground	P/W power supply (IGN)	Output	Ignition switch ON		12 V
69 (L/W)	Ground	P/W power supply (BAT)	Output	Ignition switch OFF		12 V
70 (Y)	Ground	Battery power supply	Input	Ignition switch OFF		Battery voltage
71 (R)	Ground	Tire pressure receiver communication	Input/ Output	Ignition switch ON	Standby state	 <p style="text-align: right; font-size: small;">OCC3881D</p>
					When receiving the signal from the transmitter	 <p style="text-align: right; font-size: small;">OCC3880D</p>
72 (R/W)	Ground	Back door lock actuator relay control	Output	Back door	LOCK (Actuator is activated)	0 V
					Other than LOCK (Actuator is not activated)	Battery voltage
75 (SB)	Ground	Driver door request switch	Input	Driver door request switch	ON (Pressed)	0 V
					OFF (Not pressed)	12 V
76 (G)	Ground	Passenger door request switch	Input	Passenger door request switch	ON (Pressed)	0 V
					OFF (Not pressed)	12 V
77 (W)	Ground	Back door request switch	Input	Back door request switch	ON (Pressed)	0 V
					OFF (Not pressed)	12 V

A  
B  
C  
D  
E  
F  
G  
H  
J  
K  
L  
M  
N  
O  
P

HAC

# BCM (BODY CONTROL MODULE)

< ECU DIAGNOSIS INFORMATION >

[AUTOMATIC AIR CONDITIONING]

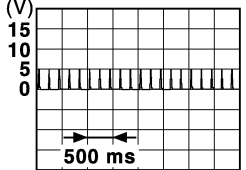
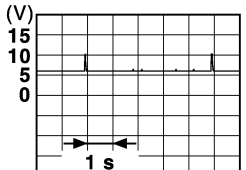
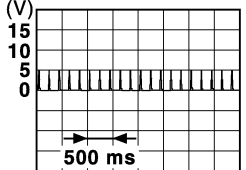
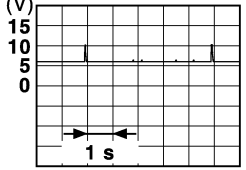
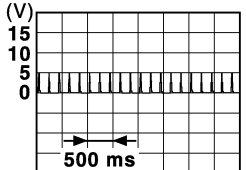
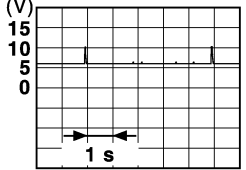
Terminal No. (Wire color)		Description		Condition	Value (Approx.)
+	-	Signal name	Input/ Output		
78 (LG)	Ground	Driver door antenna (+)	Output	When Intelligent Key is not in the antenna detec- tion area	 <p style="text-align: right; font-size: small;">JMKIA3838GB</p>
				When the driver door request switch is operat- ed with ignition switch OFF	 <p style="text-align: right; font-size: small;">JMKIA3839GB</p>
79 (V)	Ground	Driver door antenna (-)	Output	When Intelligent Key is not in the antenna detec- tion area	 <p style="text-align: right; font-size: small;">JMKIA3838GB</p>
				When the driver door request switch is operat- ed with ignition switch OFF	 <p style="text-align: right; font-size: small;">JMKIA3839GB</p>
80 (BR/Y)	Ground	Passenger door an- tenna (+)	Output	When Intelligent Key is not in the antenna detec- tion area	 <p style="text-align: right; font-size: small;">JMKIA3838GB</p>
				When the pas- senger door re- quest switch is operated with ignition switch OFF	 <p style="text-align: right; font-size: small;">JMKIA3839GB</p>

# BCM (BODY CONTROL MODULE)

< ECU DIAGNOSIS INFORMATION >

[AUTOMATIC AIR CONDITIONING]

Terminal No. (Wire color)		Description		Condition	Value (Approx.)
+	-	Signal name	Input/ Output		
81 (L/Y)	Ground	Passenger door antenna (-)	Output	When Intelligent Key is not in the antenna detection area	<p>JMKIA3838GB</p>
				When the passenger door request switch is operated with ignition switch OFF	<p>JMKIA3839GB</p>
82 (W/B)	Ground	Back door antenna (+)	Output	When Intelligent Key is not in the antenna detection area	<p>JMKIA3838GB</p>
				When the back door request switch is operated with ignition switch OFF	<p>JMKIA3839GB</p>
83 (B/W)	Ground	Back door antenna (-)	Output	When Intelligent Key is not in the antenna detection area	<p>JMKIA3838GB</p>
				When the back door request switch is operated with ignition switch OFF	<p>JMKIA3839GB</p>

A  
B  
C  
D  
E  
F  
G  
H  
J  
K  
L  
M  
N  
O  
P

HAC

# BCM (BODY CONTROL MODULE)

< ECU DIAGNOSIS INFORMATION >

[AUTOMATIC AIR CONDITIONING]

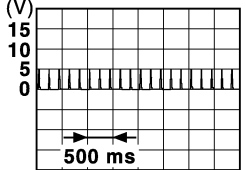
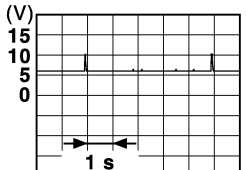
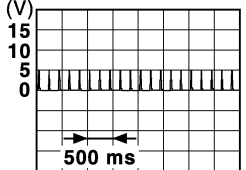
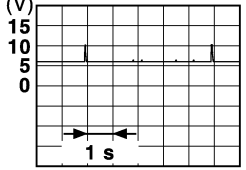
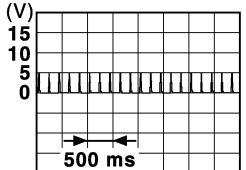
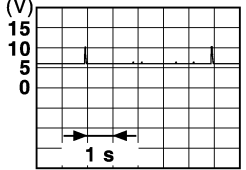
Terminal No. (Wire color)		Description		Condition	Value (Approx.)
+	-	Signal name	Input/ Output		
84 (Y/G)	Ground	Room antenna (+) (Instrument panel)	Output	Ignition switch OFF	 <p style="text-align: right; font-size: small;">JMKIA3838GB</p>
				Ignition switch ON	 <p style="text-align: right; font-size: small;">JMKIA3839GB</p>
85 (Y/L)	Ground	Room antenna (-) (Instrument panel)	Output	Ignition switch OFF	 <p style="text-align: right; font-size: small;">JMKIA3838GB</p>
				Ignition switch ON	 <p style="text-align: right; font-size: small;">JMKIA3839GB</p>
86 (P)	Ground	Luggage room antenna (+)	Output	Ignition switch OFF	 <p style="text-align: right; font-size: small;">JMKIA3838GB</p>
				Ignition switch ON	 <p style="text-align: right; font-size: small;">JMKIA3839GB</p>

# BCM (BODY CONTROL MODULE)

< ECU DIAGNOSIS INFORMATION >

[AUTOMATIC AIR CONDITIONING]

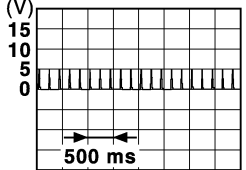
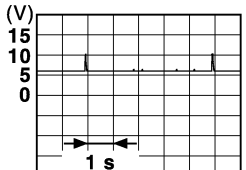
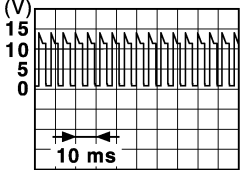
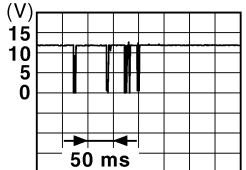
Terminal No. (Wire color)		Description		Condition	Value (Approx.)	
+	-	Signal name	Input/ Output			
87 (L)	Ground	Luggage room antenna (-)	Output	Ignition switch OFF	When Intelligent Key is not in the antenna detection area	 <p style="text-align: right; font-size: small;">JMKIA3838GB</p>
					When Intelligent Key is in the antenna detection area	 <p style="text-align: right; font-size: small;">JMKIA3839GB</p>
90 (W/L)	Ground	Push-button ignition switch illumination	Output	Push-button ignition switch illumination	ON	12 V
					OFF	0 V
91 (Y)	Ground	ACC/ON indicator lamp	Output	Ignition switch	OFF	Battery voltage
					ACC or ON	0.5 V
92 (BR/R)	Ground	Push-button ignition switch illumination ground	Output	Tail lamp	OFF	0 V
					ON	<p style="text-align: center;"><b>NOTE:</b> When the illumination brightening/dimming level is in the neutral position</p>  <p style="text-align: right; font-size: small;">JPMIA1554GB</p> <p style="text-align: center;">6.0 - 7.0 V</p>
93 (GR/W)	Ground	Intelligent Key warning buzzer	Output	Intelligent Key warning buzzer	Sounding	0 V
					Not sounding	12 V
94 (Y/R)	Ground	Steering lock unit communication	Input/ Output	Steering lock	LOCK status	12 V
					LOCK or UNLOCK	 <p style="text-align: right; font-size: small;">JMKIA0066GB</p>
					For 15 seconds after UNLOCK	12 V
					15 seconds or later after UNLOCK	0 V
95 (W/G)	Ground	Steering lock unit power supply	Output	Ignition switch	OFF or ACC	12 V
					ON	0 V

A  
B  
C  
D  
E  
F  
G  
H  
HAC  
J  
K  
L  
M  
N  
O  
P

## BCM (BODY CONTROL MODULE)

< ECU DIAGNOSIS INFORMATION >

[AUTOMATIC AIR CONDITIONING]

Terminal No. (Wire color)		Description		Condition		Value (Approx.)
+	-	Signal name	Input/ Output			
96 (G)	Ground	ACC relay control	Output	Ignition switch	OFF	0 V
					ACC or ON	12 V
97 (L/R)	Ground	Starter relay control	Output	Ignition switch ON	When selector lever is in P or N position	Battery voltage
					When selector lever is not in P or N position	0 V
98 (BR)	Ground	Ignition relay (IPDM E/R) control	Output	Ignition switch	OFF or ACC	12 V
					ON	0 V
99 (W/R)	Ground	Ignition relay control	Output	Ignition switch	OFF or ACC	0 V
					ON	12 V
100 (L/O)	Ground	Push-button ignition switch (push switch)	Input	Push-button ig- nition switch (push switch)	Pressed	0 V
					Not pressed	12 V
102 (G)	Ground	Selector lever P/N position	Input	Selector lever	P or N position	Battery voltage
					Except P and N positions	0 V
104 (Y/R)	Ground	CVT shift selector (detention switch) power supply	Output	Ignition switch ON		12 V
105 (B/O)	Ground	Stop lamp switch 2	Input	Ignition switch OFF		Battery voltage
106 (Y/B)	Ground	Blower fan motor re- lay control	Output	Ignition switch	OFF or ACC	0 V
					ON	12 V
107 (L/W)	Ground	Steering lock condi- tion No. 1	Input	Steering lock	LOCK status	0 V
					UNLOCK status	12 V
108 (P/L)	Ground	Steering lock condi- tion No. 2	Input	Steering lock	LOCK status	12 V
					UNLOCK status	0 V
110 (BR/W)	Ground	Tire pressure receiv- er power supply	Output	Ignition switch	OFF or ACC	0 V
					ON	5 V

\*: For Canada

BCM (BODY CONTROL SYSTEM) (WITH INTELLIGENT KEY SYSTEM) : Wiring Di-

# BCM (BODY CONTROL MODULE)

[AUTOMATIC AIR CONDITIONING]

< ECU DIAGNOSIS INFORMATION >

agram - BCM -

INFOID:000000005819855

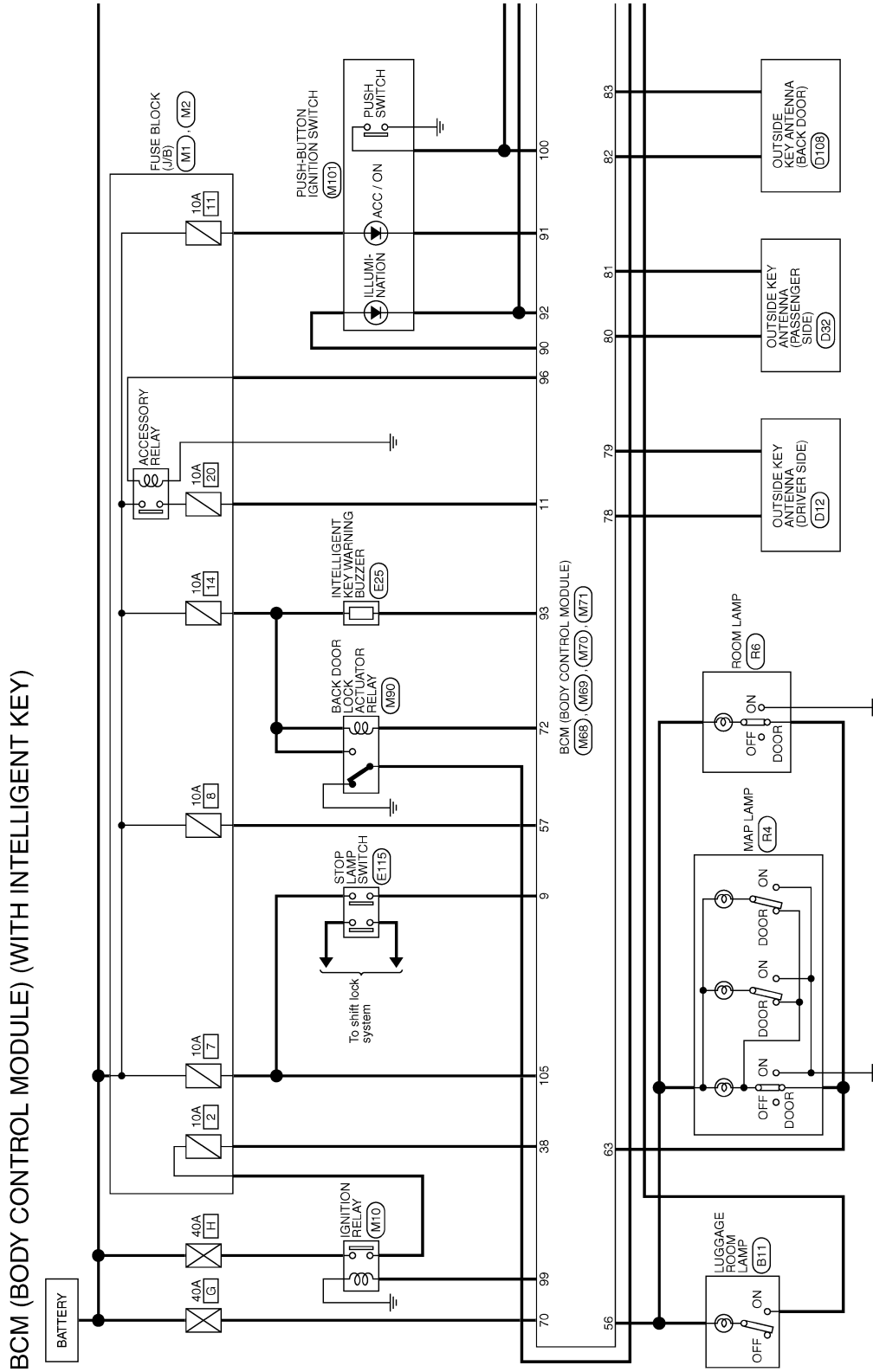

A  
B  
C  
D  
E  
F  
G  
H  
HAC  
J  
K  
L  
M  
N  
O  
P

# BCM (BODY CONTROL MODULE)

< ECU DIAGNOSIS INFORMATION >

[AUTOMATIC AIR CONDITIONING]

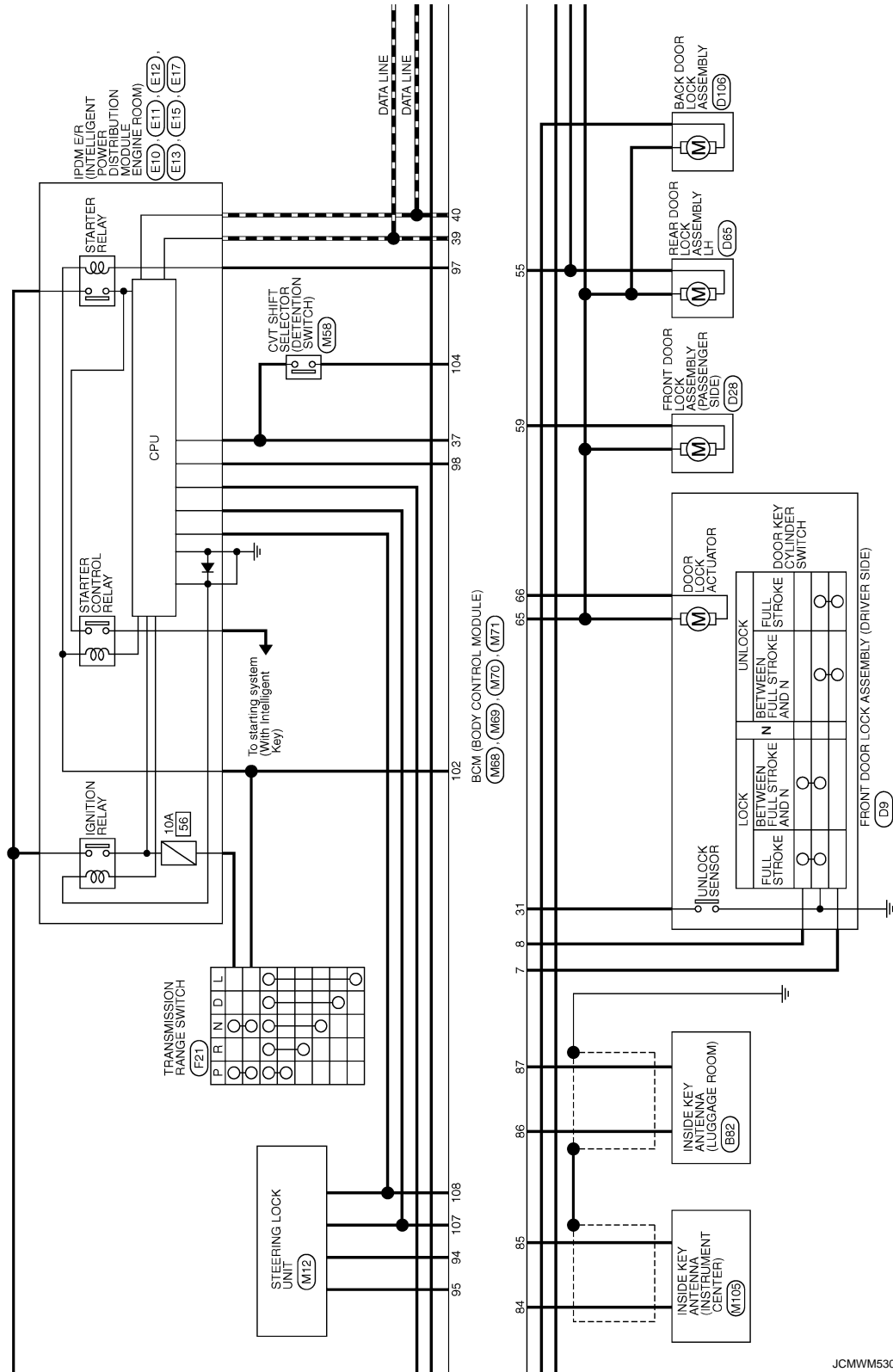

JCMWM5306G



# BCM (BODY CONTROL MODULE)

< ECU DIAGNOSIS INFORMATION >

[AUTOMATIC AIR CONDITIONING]

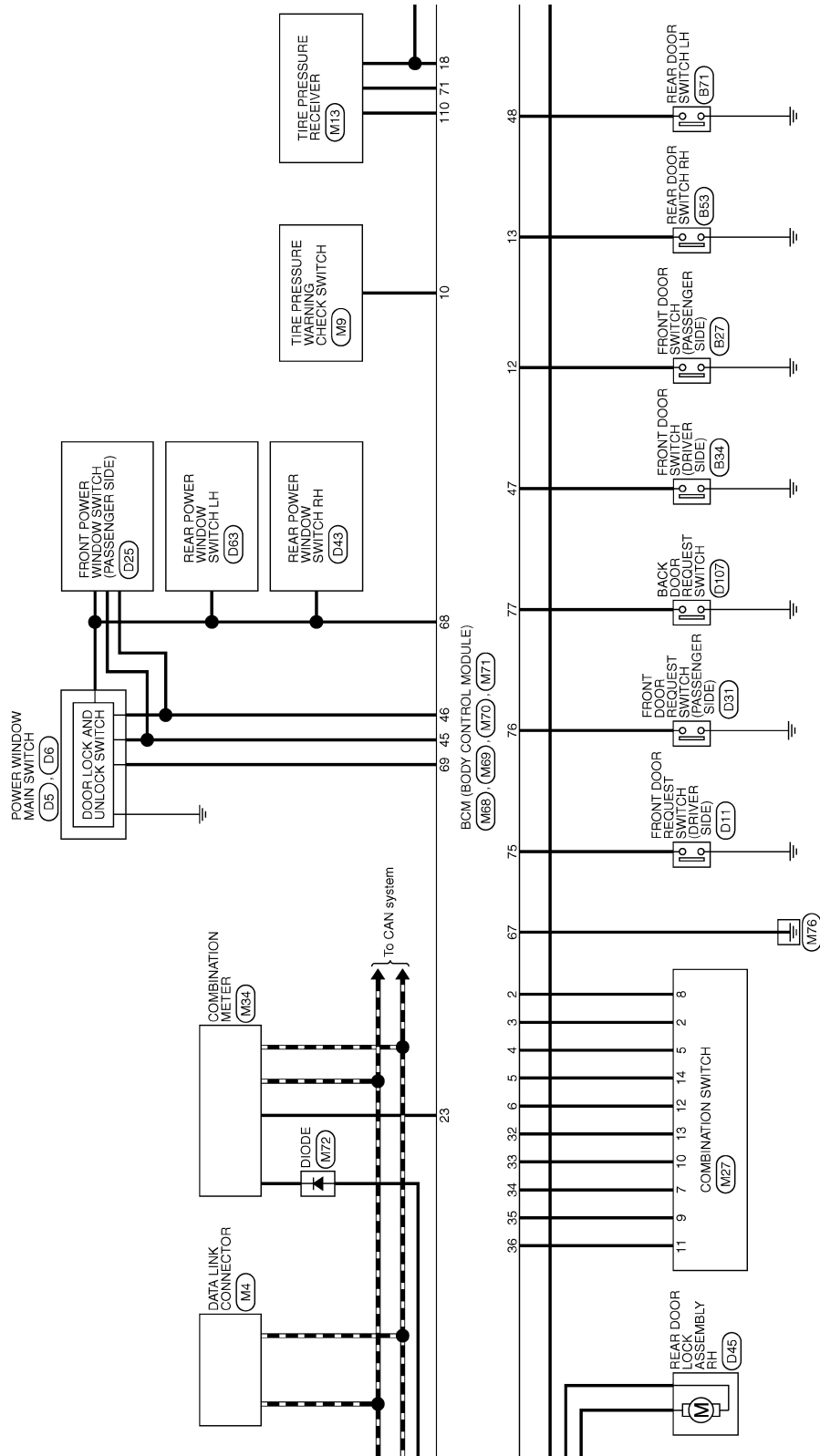

JCMWM5307G1

A  
B  
C  
D  
E  
F  
G  
H  
HAC  
J  
K  
L  
M  
N  
O  
P

# BCM (BODY CONTROL MODULE)

< ECU DIAGNOSIS INFORMATION >

[AUTOMATIC AIR CONDITIONING]

For Canada

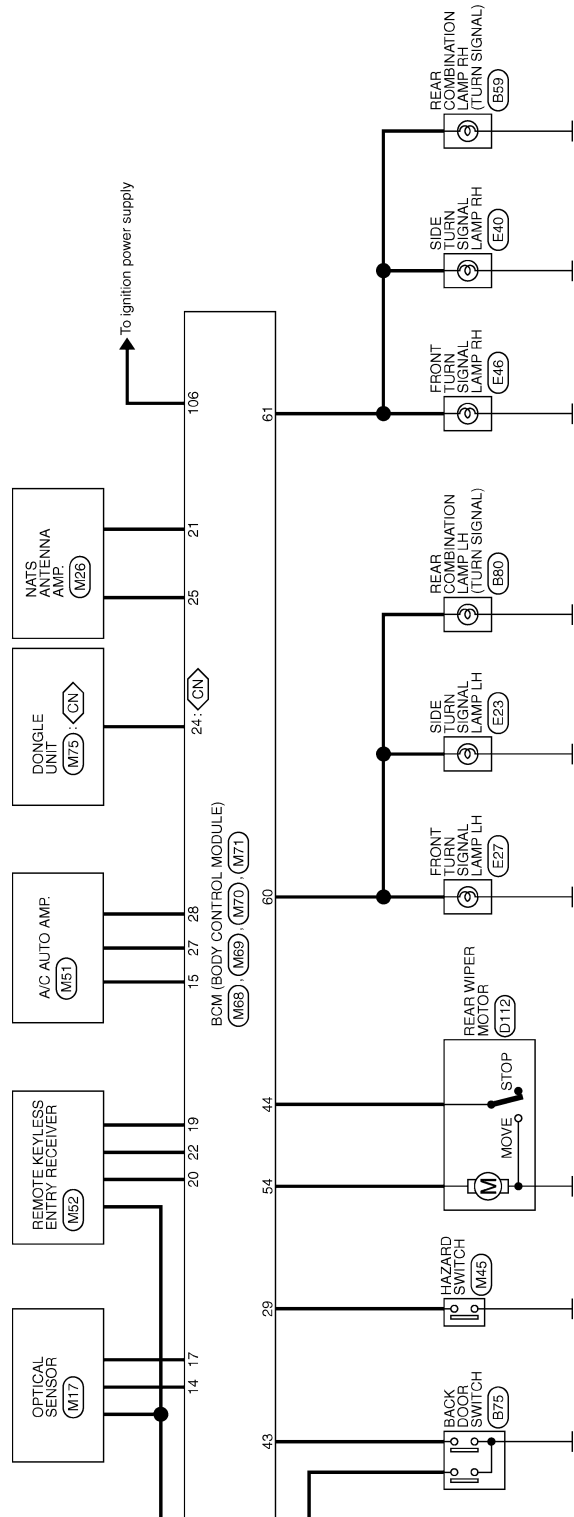

JCMWM5308G

# BCM (BODY CONTROL MODULE)

[AUTOMATIC AIR CONDITIONING]

< ECU DIAGNOSIS INFORMATION >

Terminal No.	Color of Wire	Signal Name [Specification]
83	B/W	BACK DOOR ANT-
84	Y/G	ROOM ANT+
85	Y/L	ROOM ANT-
86	P	LUGGAGE ROOM ANT+
87	L	LUGGAGE ROOM ANT-
90	W/L	PUSH-BUTTON IGNITION SW ILL POWER
91	Y	ACC/ON IND
92	BR/R	PUSH-BUTTON IGNITION SW ILL GND
93	GR/W	H-KEY WARN BUZZER
94	Y/R	S/L UNIT COMM
95	W/G	S/L UNIT POWER SUPPLY
96	G	ACC RELAY CONT
97	L/R	STARTER RELAY CONT
98	BR	IGN RELAY (IPOM E/R) CONT
99	W/R	IGN RELAY CONT
100	L/O	PUSH SW
102	G	SHIFT N/P
104	Y/B	CVT SHIFT SELECTOR POWER SUPPLY
105	B/O	STOP LAMP SW 2
106	Y/B	BLOWER FAN MOTOR RELAY CONT
107	L/W	S/L CONDITION 1
108	P/L	S/L CONDITION 2
110	BR/W	TIRE PRESS POWER SUPPLY

Connector No.	M70
Connector Name	BCM (BODY CONTROL MODULE)
Connector Type	FEA08FB-FH46-SA

65	66	67	68	69	70
----	----	----	----	----	----

Terminal No.	Color of Wire	Signal Name [Specification]
56	L	INTERIOR ROOM LAMP POWER SUPPLY
57	Y	BAT (FUZE)
59	G	PASSENGER DOOR UNLOCK OUTPUT
61	W/B	TURN SIGNAL LH OUTPUT
62	W/L	TURN SIGNAL RH OUTPUT
63	BR	ROOM LAMP TIMER CONTROL
65	V	ALL DOOR LOCK OUTPUT
66	L/B	DRIVER DOOR UNLOCK OUTPUT
67	B	GND
68	L	POWER WINDOW POWER SUPPLY (IGN)
69	L/W	POWER WINDOW POWER SUPPLY (BAT)
70	Y	BAT (F/L)

Connector No.	M71
Connector Name	BCM (BODY CONTROL MODULE)
Connector Type	TH40FW-NH

71	72	73	74	75	76	77	78	79	80	81	82
----	----	----	----	----	----	----	----	----	----	----	----

Terminal No.	Color of Wire	Signal Name [Specification]
71	R	TIRE PRESS RECEIVER COMM
72	R/W	BK DR LOCK ACT RELAY CONT
75	SB	DRIVER DOOR REQUEST SW
76	G	PASSENGER DOOR REQUEST SW
77	W	BACK DOOR REQUEST SW
78	LG	DRIVER DOOR ANT+
79	V	DRIVER DOOR ANT-
80	BR/Y	PASSENGER DOOR ANT+
81	L/Y	PASSENGER DOOR ANT-
82	W/B	BACK DOOR ANT-

Terminal No.	Color of Wire	Signal Name [Specification]
10	V/W	TIRE PRESS WARNING CHECK SW
11	L/Y	ACC F/B
12	SB	PASSENGER DOOR SW
13	GR/L	REAR RH DOOR SW
14	L/B	OPTICAL SENSOR
15	W/L	REAR WINDOW DEFOGGER SW
17	R/G	OPTICAL SENSOR POWER SUPPLY
18	V	RECEIVER / SENSOR GND
19	BR	KEYLESS ENTRY RECEIVER POWER SUPPLY
20	G/Y	KEYLESS ENTRY RECEIVER COMM
21	P/L	NATS ANTENNA AMP
22	W/G	KEYLESS ENTRY RECEIVER RSSI
23	R/Y	SECURITY INDICATOR LAMP
24	GR/R	DOUBLE LINK
25	LG	NATS ANTENNA AMP
27	Y/R	A/G SW
28	G/W	BLOWER FAN SW
29	L/W	HAZARD SW
31	G/B	DR DOOR UNLOCK SENSOR
32	L/G	COMBI SW OUTPUT 5
33	Y/L	COMBI SW OUTPUT 4
34	W	COMBI SW OUTPUT 3
35	R/L	COMBI SW OUTPUT 2
36	L/O	COMBI SW OUTPUT 1
37	G/O	SHIFT P
38	O	IGN F/B
39	L	CAN-H
40	P	CAN-L

## BCM (BODY CONTROL MODULE) (WITH INTELLIGENT KEY)

Connector No.	M27
Connector Name	COMBINATION SWITCH
Connector Type	TH16FW-NH

1	2	3	4	5	6		
7	8	9	10	11	12	13	14

Terminal No.	Color of Wire	Signal Name [Specification]
1	O	WASHER (RR)
2	GR	INPUT 4
3	L	WASHER (FR)
4	W	IGN
5	L/Y	INPUT 3
6	B	GND
7	W	OUTPUT 3
8	BR/W	INPUT 5
9	R/L	OUTPUT 2
10	Y/L	OUTPUT 4
11	L/O	OUTPUT 1
12	L/R	INPUT 1
13	LG	OUTPUT 5
14	G	INPUT 2

Connector No.	M69
Connector Name	BCM (BODY CONTROL MODULE)
Connector Type	FEA08FW-FH46-SA

41	42	43	44	45	46	47	48	49
50	51	52	53	54	55			

Terminal No.	Color of Wire	Signal Name [Specification]
43	W	BACK DOOR SW
44	LG	REAR WIPER STOP POSITION
45	GR	CENTRAL DOOR LOCK SW
46	BR	CENTRAL DOOR UNLOCK SW
47	BR/Y	DRIVER DOOR SW
48	W/G	REAR LH DOOR SW
54	L/W	REAR WIPER OUTPUT
55	G	REAR DOOR UNLOCK OUTPUT

Connector No.	M68
Connector Name	BCM (BODY CONTROL MODULE)
Connector Type	TH40FB-NH

1	2	3	4	5	6	7	8	9
---	---	---	---	---	---	---	---	---

Terminal No.	Color of Wire	Signal Name [Specification]
2	BR/W	COMBI SW INPUT 5
3	GR	COMBI SW INPUT 4
4	L/Y	COMBI SW INPUT 3
5	G	COMBI SW INPUT 2
6	L/R	COMBI SW INPUT 1
7	W/B	KEY CYL UNLOCK SW
8	W/B	KEY CYL LOCK SW
9	R	STOP LAMP SW 1

JCMW5309G1

## BCM (BODY CONTROL SYSTEM) (WITH INTELLIGENT KEY SYSTEM) : Fail-safe

INFOID:000000005819856

### FAIL-SAFE CONTROL BY DTC

BCM performs fail-safe control when any DTC are detected.

A B C D E F G H I J K L M N O P

HAC

# BCM (BODY CONTROL MODULE)

< ECU DIAGNOSIS INFORMATION >

[AUTOMATIC AIR CONDITIONING]

Display contents of CONSULT	Fail-safe	Cancellation
B2013: ID DISCORD BCM-S/L	Inhibit engine cranking	When communication between BCM and steering lock unit are communicated normally.
B2014: CHAIN OF S/L-BCM	Inhibit engine cranking	When communication between BCM and steering lock unit are communicated normally.
B2192: ID DISCORD BCM-ECM	Inhibit engine cranking	Erase DTC
B2193: CHAIN OF BCM-ECM	Inhibit engine cranking	Erase DTC
B2195: ANTI-SCANNING	Inhibit engine cranking	Ignition switch ON → OFF
B2196: DONGLE NG	Inhibit engine cranking	Erase DTC
B2198: NATS ANTENNA AMP	Inhibit engine cranking	Erase DTC
B2557: VEHICLE SPEED	Inhibit steering lock	When the following CAN signal status (vehicle speed signal) becomes consistent <ul style="list-style-type: none"> <li>• Vehicle speed signal (ABS)</li> <li>• Vehicle speed signal (Meter)</li> </ul>
B2601: SHIFT POSITION	Inhibit steering lock	500 ms after the following signal reception status becomes consistent <ul style="list-style-type: none"> <li>• Selector lever P position switch signal</li> <li>• P range signal (CAN)</li> </ul>
B2602: SHIFT POSITION	Inhibit steering lock	5 seconds after the following BCM recognition conditions are fulfilled <ul style="list-style-type: none"> <li>• Ignition switch is in the ON position</li> <li>• Selector lever P position switch signal: Except P position (battery voltage)</li> <li>• Vehicle speed: 4 km/h (2.5 MPH) or more</li> </ul>
B2603: SHIFT POSI STATUS	Inhibit steering lock	500 ms after any of the following BCM recognition conditions are fulfilled <ul style="list-style-type: none"> <li>• Status 1 <ul style="list-style-type: none"> <li>- Ignition switch is in the ON position</li> <li>- Selector lever P position switch signal: Except P position (12 V)</li> <li>- Selector lever P/N position signal: Except P and N positions (0 V)</li> </ul> </li> <li>• Status 2 <ul style="list-style-type: none"> <li>- Ignition switch is in the ON position</li> <li>- Selector lever P position switch signal: P position (0 V)</li> <li>- Selector lever P/N position signal: P or N positions (12 V)</li> </ul> </li> </ul>
B2604: PNP/CLUTCH SW	Inhibit steering lock	500 ms after any of the following BCM recognition conditions are fulfilled <ul style="list-style-type: none"> <li>• Status 1 <ul style="list-style-type: none"> <li>- Ignition switch is in the ON position</li> <li>- Selector lever P/N position signal: P or N position (12 V)</li> <li>- Shift position signal (CAN): P or N position</li> </ul> </li> <li>• Status 2 <ul style="list-style-type: none"> <li>- Ignition switch is in the ON position</li> <li>- Selector lever P/N position signal: Except P and N positions (0 V)</li> <li>- Shift position signal (CAN): Except P and N position</li> </ul> </li> </ul>
B2605: PNP/CLUTCH SW	Inhibit steering lock	500 ms after any of the following BCM recognition conditions are fulfilled <ul style="list-style-type: none"> <li>• Status 1 <ul style="list-style-type: none"> <li>- Power position: IGN</li> <li>- Selector lever P/N position signal: Except P and N positions (0 V)</li> <li>- Interlock/PNP switch signal (CAN): OFF</li> </ul> </li> <li>• Status 2 <ul style="list-style-type: none"> <li>- Ignition switch is in the ON position</li> <li>- Selector lever P/N position signal: P or N position (12 V)</li> <li>- Interlock/PNP switch signal (CAN): ON</li> </ul> </li> </ul>
B2608: STARTER RELAY	Inhibit engine cranking	500 ms after the following signal communication status becomes consistent <ul style="list-style-type: none"> <li>• Starter motor relay control signal</li> <li>• Starter relay status signal (CAN)</li> </ul>
B2609: S/L STATUS	<ul style="list-style-type: none"> <li>• Inhibit engine cranking</li> <li>• Inhibit steering lock</li> </ul>	When the following steering lock conditions agree <ul style="list-style-type: none"> <li>• BCM steering lock control status</li> <li>• Steering lock condition No. 1 signal status</li> <li>• Steering lock condition No. 2 signal status</li> </ul>
B260B: STEERING LOCK UNIT	Inhibit steering lock	Erase DTC

## BCM (BODY CONTROL MODULE)

< ECU DIAGNOSIS INFORMATION >

[AUTOMATIC AIR CONDITIONING]

Display contents of CONSULT	Fail-safe	Cancellation
B260D: STEERING LOCK UNIT	Inhibit steering lock	Erase DTC
B260F: ENG STATE SIG LOST	Inhibit engine cranking	When any of the following conditions are fulfilled <ul style="list-style-type: none"> <li>• Power position changes to ACC</li> <li>• Receives engine status signal (CAN)</li> </ul>
B2612: S/L STATUS	<ul style="list-style-type: none"> <li>• Inhibit engine cranking</li> <li>• Inhibit steering lock</li> </ul>	When any of the following conditions are fulfilled <ul style="list-style-type: none"> <li>• Steering lock unit status signal (CAN) is received normally</li> <li>• The BCM steering lock control status matches the steering lock status recognized by the steering lock unit status signal (CAN from IPDM E/R)</li> </ul>
B2619: BCM	Inhibit engine cranking	1 second after the steering lock unit power supply output control inside BCM becomes normal
B26EF: STRG LCK RELAY OFF	Inhibit engine cranking	When the following conditions are fulfilled <ul style="list-style-type: none"> <li>• Steering lock relay signal (CAN): ON</li> <li>• Steering lock unit status signal (CAN): ON</li> </ul>
B26F0: STRG LCK RELAY ON	Inhibit engine cranking	When the following conditions are fulfilled <ul style="list-style-type: none"> <li>• Steering lock relay signal (CAN): OFF</li> <li>• Steering lock unit status signal (CAN): OFF</li> </ul>
B26F1: IGN RELAY OFF	Inhibit engine cranking	When the following conditions are fulfilled <ul style="list-style-type: none"> <li>• Ignition switch ON signal (CAN: Transmitted from BCM): ON</li> <li>• Ignition switch ON signal (CAN: Transmitted from IPDM E/R): ON</li> </ul>
B26F2: IGN RELAY ON	Inhibit engine cranking	When the following conditions are fulfilled <ul style="list-style-type: none"> <li>• Ignition switch ON signal (CAN: Transmitted from BCM): OFF</li> <li>• Ignition switch ON signal (CAN: Transmitted from IPDM E/R): OFF</li> </ul>
B26F3: START CONT RLY ON	Inhibit engine cranking	When the following conditions are fulfilled <ul style="list-style-type: none"> <li>• Starter control relay signal (CAN: Transmitted from BCM): OFF</li> <li>• Starter control relay signal (CAN: Transmitted from IPDM E/R): OFF</li> </ul>
B26F4: START CONT RLY OFF	Inhibit engine cranking	When the following conditions are fulfilled <ul style="list-style-type: none"> <li>• Starter control relay signal (CAN: Transmitted from BCM): ON</li> <li>• Starter control relay signal (CAN: Transmitted from IPDM E/R): ON</li> </ul>
B26F7: BCM	Inhibit engine cranking by Intelligent Key system	When room antenna and luggage room antenna functions normally
U0415: VEHICLE SPEED	Inhibit steering lock	When vehicle speed signal (Meter) (CAN) is received normally

### REAR WIPER MOTOR PROTECTION

BCM detects the rear wiper stopping position according to the rear wiper stop position signal. When the rear wiper stop position signal does not change for more than 5 seconds while driving the rear wiper, BCM stops power supply to protect the rear wiper motor.

Condition of cancellation

1. More than 1 minute is passed after the rear wiper stop.
2. Turn rear wiper switch OFF.
3. Operate the rear wiper switch or rear washer switch.

### BCM (BODY CONTROL SYSTEM) (WITH INTELLIGENT KEY SYSTEM) : DTC Inspection Priority Chart

INFOID:000000005819857

If some DTCs are displayed at the same time, perform inspections one by one based on the following priority chart.

Priority	DTC
1	B2562: LOW VOLTAGE
2	<ul style="list-style-type: none"> <li>• U1000: CAN COMM CIRCUIT</li> <li>• U1010: CONTROL UNIT (CAN)</li> </ul>

# BCM (BODY CONTROL MODULE)

< ECU DIAGNOSIS INFORMATION >

[AUTOMATIC AIR CONDITIONING]

Priority	DTC
3	<ul style="list-style-type: none"> <li>• B2192: ID DISCORD BCM-ECM</li> <li>• B2193: CHAIN OF BCM-ECM</li> <li>• B2195: ANTI-SCANNING</li> <li>• B2196: DONGLE NG</li> <li>• B2198: NATS ANTENNA AMP</li> </ul>
4	<ul style="list-style-type: none"> <li>• B2013: ID DISCORD BCM-S/L</li> <li>• B2014: CHAIN OF S/L-BCM</li> <li>• B2553: IGNITION RELAY</li> <li>• B2555: STOP LAMP</li> <li>• B2556: PUSH-BTN IGN SW</li> <li>• B2557: VEHICLE SPEED</li> <li>• B2601: SHIFT POSITION</li> <li>• B2602: SHIFT POSITION</li> <li>• B2603: SHIFT POSI STATUS</li> <li>• B2604: PNP/CLUTCH SW</li> <li>• B2605: PNP/CLUTCH SW</li> <li>• B2608: STARTER RELAY</li> <li>• B2609: S/L STATUS</li> <li>• B260B: STEERING LOCK UNIT</li> <li>• B260C: STEERING LOCK UNIT</li> <li>• B260D: STEERING LOCK UNIT</li> <li>• B260F: ENG STATE SIG LOST</li> <li>• B2612: S/L STATUS</li> <li>• B2614: BCM</li> <li>• B2615: BCM</li> <li>• B2616: BCM</li> <li>• B2618: BCM</li> <li>• B2619: BCM</li> <li>• B261A: PUSH-BTN IGN SW</li> <li>• B26E9: LOCK MALFUNCTION</li> <li>• B26EF: STRG LCK RELAY OFF</li> <li>• B26F0: STRG LCK RELAY ON</li> <li>• B26F1: IGN RELAY OFF</li> <li>• B26F2: IGN RELAY ON</li> <li>• B26F3: START CONT RLY ON</li> <li>• B26F4: START CONT RLY OFF</li> <li>• B26F5: STRG LCK STS SW</li> <li>• B26F6: BCM</li> <li>• B26F7: BCM</li> <li>• B26F8: BCM</li> <li>• B26FC: KEY REGISTRATION</li> <li>• C1729: VHCL SPEED SIG ERR</li> <li>• U0415: VEHICLE SPEED</li> </ul>
5	<ul style="list-style-type: none"> <li>• C1704: LOW PRESSURE FL</li> <li>• C1705: LOW PRESSURE FR</li> <li>• C1706: LOW PRESSURE RR</li> <li>• C1707: LOW PRESSURE RL</li> <li>• C1708: [NO DATA] FL</li> <li>• C1709: [NO DATA] FR</li> <li>• C1710: [NO DATA] RR</li> <li>• C1711: [NO DATA] RL</li> <li>• C1716: [PRESSDATA ERR] FL</li> <li>• C1717: [PRESSDATA ERR] FR</li> <li>• C1718: [PRESSDATA ERR] RR</li> <li>• C1719: [PRESSDATA ERR] RL</li> <li>• C1734: CONTROL UNIT</li> </ul>
6	<ul style="list-style-type: none"> <li>• B2621: INSIDE ANTENNA</li> <li>• B2622: INSIDE ANTENNA</li> </ul>
7	<ul style="list-style-type: none"> <li>• B2626: OUTSIDE ANTENNA</li> <li>• B2627: OUTSIDE ANTENNA</li> <li>• B2628: OUTSIDE ANTENNA</li> </ul>

# BCM (BODY CONTROL MODULE)

< ECU DIAGNOSIS INFORMATION >

[AUTOMATIC AIR CONDITIONING]

## BCM (BODY CONTROL SYSTEM) (WITH INTELLIGENT KEY SYSTEM) : DTC Index

INFOID:000000005819858

### NOTE:

The details of time display are as follows.

- CRNT: A malfunction is detected now.
- PAST: A malfunction was detected in the past.

IGN counter is displayed on Freeze Frame Data. For details of Freeze Frame Data, refer to [BCS-18. "COMMON ITEM : CONSULT-III Function \(BCM - COMMON ITEM\)"](#).

CONSULT display	Fail-safe	Freeze Frame Data •Vehicle Speed •Odo/Trip Meter •Vehicle Condition	Intelligent Key warning lamp ON	Tire pressure monitor warning lamp ON	Reference page
No DTC is detected. further testing may be required.	—	—	—	—	—
U1000: CAN COMM	—	—	—	—	<a href="#">BCS-39</a>
U1010: CONTROL UNIT (CAN)	—	—	—	—	<a href="#">BCS-40</a>
U0415: VEHICLE SPEED	×	—	×	—	<a href="#">BCS-41</a>
B2013: ID DISCORD BCM-S/L	×	×	×	—	<a href="#">SEC-45</a>
B2014: CHAIN OF S/L-BCM	×	×	×	—	<a href="#">SEC-46</a>
B2192: ID DISCORD BCM-ECM	×	—	—	—	<a href="#">SEC-35</a>
B2193: CHAIN OF BCM-ECM	×	—	—	—	<a href="#">SEC-37</a>
B2195: ANTI-SCANNING	×	—	—	—	<a href="#">SEC-38</a>
B2196: DONGLE NG	×	—	—	—	<a href="#">SEC-39</a>
B2198: NATS ANTENNA AMP	×	—	—	—	<a href="#">SEC-41</a>
B2553: IGNITION RELAY	—	×	×	—	<a href="#">PCS-77</a>
B2555: STOP LAMP	—	×	×	—	<a href="#">SEC-49</a>
B2556: PUSH-BTN IGN SW	—	×	×	—	<a href="#">SEC-51</a>
B2557: VEHICLE SPEED	×	×	×	—	<a href="#">SEC-53</a>
B2562: LOW VOLTAGE	—	×	—	—	<a href="#">BCS-42</a>
B2601: SHIFT POSITION	×	×	×	—	<a href="#">SEC-54</a>
B2602: SHIFT POSITION	×	×	×	—	<a href="#">SEC-57</a>
B2603: SHIFT POSI STATUS	×	×	×	—	<a href="#">SEC-60</a>
B2604: PNP/CLUTCH SW	×	×	×	—	<a href="#">SEC-65</a>
B2605: PNP/CLUTCH SW	×	×	×	—	<a href="#">SEC-68</a>
B2608: STARTER RELAY	×	×	×	—	<a href="#">SEC-70</a>
B2609: S/L STATUS	×	×	×	—	<a href="#">SEC-72</a>
B260B: STEERING LOCK UNIT	×	×	×	—	<a href="#">SEC-75</a>
B260C: STEERING LOCK UNIT	—	×	×	—	<a href="#">SEC-76</a>
B260D: STEERING LOCK UNIT	×	×	×	—	<a href="#">SEC-77</a>
B260F: ENG STATE SIG LOST	×	×	×	—	<a href="#">SEC-78</a>
B2612: S/L STATUS	×	×	×	—	<a href="#">SEC-79</a>
B2614: BCM	—	×	×	—	<a href="#">PCS-79</a>
B2615: BCM	—	×	×	—	<a href="#">PCS-82</a>
B2616: BCM	—	×	×	—	<a href="#">PCS-85</a>
B2618: BCM	—	×	×	—	<a href="#">PCS-88</a>

# BCM (BODY CONTROL MODULE)

< ECU DIAGNOSIS INFORMATION >

[AUTOMATIC AIR CONDITIONING]

CONSULT display	Fail-safe	Freeze Frame Data •Vehicle Speed •Odo/Trip Meter •Vehicle Condition	Intelligent Key warning lamp ON	Tire pressure monitor warning lamp ON	Reference page
B2619: BCM	×	×	×	—	<a href="#">SEC-82</a>
B261A: PUSH-BTN IGN SW	—	×	×	—	<a href="#">PCS-89</a>
B2621: INSIDE ANTENNA	—	×	—	—	<a href="#">DLK-44</a>
B2622: INSIDE ANTENNA	—	×	—	—	<a href="#">DLK-46</a>
B2626: OUTSIDE ANTENNA	—	×	—	—	<a href="#">DLK-48</a>
B2627: OUTSIDE ANTENNA	—	×	—	—	<a href="#">DLK-50</a>
B2628: OUTSIDE ANTENNA	—	×	—	—	<a href="#">DLK-52</a>
B26E9: LOCK MALFUNCTION	—	×	× (Turn ON for 15 seconds)	—	<a href="#">SEC-83</a>
B26EF: STRG LCK RELAY OFF	×	×	×	—	<a href="#">SEC-84</a>
B26F0: STRG LCK RELAY ON	×	×	×	—	<a href="#">SEC-86</a>
B26F1: IGN RELAY OFF	×	×	×	—	<a href="#">PCS-91</a>
B26F2: IGN RELAY ON	×	×	×	—	<a href="#">PCS-94</a>
B26F3: START CONT RLY ON	×	×	×	—	<a href="#">SEC-87</a>
B26F4: START CONT RLY OFF	×	×	×	—	<a href="#">SEC-88</a>
B26F5: STRG LCK STS SW	—	×	×	—	<a href="#">SEC-90</a>
B26F6: BCM	—	×	×	—	<a href="#">PCS-97</a>
B26F7: BCM	×	×	×	—	<a href="#">SEC-93</a>
B26F8: BCM	—	×	×	—	<a href="#">SEC-94</a>
B26FC: KEY REGISTRATION	—	×	×	—	<a href="#">SEC-95</a>
C1704: LOW PRESSURE FL	—	—	—	×	<a href="#">WT-30</a>
C1705: LOW PRESSURE FR	—	—	—	×	
C1706: LOW PRESSURE RR	—	—	—	×	
C1707: LOW PRESSURE RL	—	—	—	×	
C1708: [NO DATA] FL	—	—	—	×	<a href="#">WT-32</a>
C1709: [NO DATA] FR	—	—	—	×	
C1710: [NO DATA] RR	—	—	—	×	
C1711: [NO DATA] RL	—	—	—	×	
C1716: [PRESSDATA ERR] FL	—	—	—	×	<a href="#">WT-35</a>
C1717: [PRESSDATA ERR] FR	—	—	—	×	
C1718: [PRESSDATA ERR] RR	—	—	—	×	
C1719: [PRESSDATA ERR] RL	—	—	—	×	
C1729: VHCL SPEED SIG ERR	—	—	—	×	<a href="#">WT-37</a>
C1734: CONTROL UNIT	—	—	—	×	<a href="#">WT-39</a>

## BCM (BODY CONTROL SYSTEM) (WITHOUT INTELLIGENT KEY SYSTEM)

BCM (BODY CONTROL SYSTEM) (WITHOUT INTELLIGENT KEY SYSTEM) : Reference Value

INFOID:000000005819859

VALUES ON THE DIAGNOSIS TOOL



# BCM (BODY CONTROL MODULE)

< ECU DIAGNOSIS INFORMATION >

[AUTOMATIC AIR CONDITIONING]

Monitor Item	Condition	Value/Status
IGN ON SW	Ignition switch OFF or ACC	Off
	Ignition switch ON	On
KEY ON SW	Mechanical key is removed from key cylinder	Off
	Mechanical key is inserted to key cylinder	On
CDL LOCK SW	Door lock/unlock switch does not operate	Off
	Press door lock/unlock switch to the lock side	On
CDL UNLOCK SW	Door lock/unlock switch does not operate	Off
	Press door lock/unlock switch to the unlock side	On
DOOR SW-DR	Driver's door closed	Off
	Driver's door opened	On
DOOR SW-AS	Passenger door closed	Off
	Passenger door opened	On
DOOR SW-RR	Rear RH door closed	Off
	Rear RH door opened	On
DOOR SW-RL	Rear LH door closed	Off
	Rear LH door opened	On
BACK DOOR SW	Back door closed	Off
	Back door opened	On
LOCK STATUS	<b>NOTE:</b> The item is indicated, but not monitored.	Off
ACC ON SW	Ignition switch OFF	Off
	Ignition switch ACC or ON	On
KEYLESS LOCK	"LOCK" button of key fob is not pressed	Off
	"LOCK" button of key fob is pressed	On
KEYLESS UNLOCK	"UNLOCK" button of key fob is not pressed	Off
	"UNLOCK" button of key fob is pressed	On
SHOCK SENSOR	<b>NOTE:</b> The item is indicated, but not monitored.	NORMAL
KEY CYL LK-SW	Other than driver door key cylinder LOCK position	Off
	Driver door key cylinder LOCK position	On
KEY CYL UN-SW	Other than driver door key cylinder UNLOCK position	Off
	Driver door key cylinder UNLOCK position	On
VEHICLE SPEED	While driving	Equivalent to speedometer reading
REAR DEF SW	Rear window defogger switch OFF	Off
	Rear window defogger switch ON	On
REVERSE SW CAN	<b>NOTE:</b> The item is indicated, but not used.	Off
		On
TAIL LAMP SW	Lighting switch OFF	Off
	Lighting switch 1ST	On
FR FOG SW	Front fog lamp switch OFF	Off
	Front fog lamp switch ON	On
BUCKLE SW	The seat belt (driver side) is fastened. [Seat belt switch (driver side) OFF]	Off
	The seat belt (driver side) is unfastened. [Seat belt switch (driver side) ON]	On

A  
B  
C  
D  
E  
F  
G  
H  
HAC  
J  
K  
L  
M  
N  
O  
P

# BCM (BODY CONTROL MODULE)

< ECU DIAGNOSIS INFORMATION >

[AUTOMATIC AIR CONDITIONING]

Monitor Item	Condition	Value/Status
TRNK/HAT MNTR	<b>NOTE:</b> The item is indicated, but not monitored.	Off
ACC SW	Ignition switch OFF	Off
	Ignition switch ACC or ON	On
KYLS TRNK/HAT	<b>NOTE:</b> The item is indicated, but not monitored.	Off
KEYLESS PANIC	PANIC button of key fob is not pressed	Off
	PANIC button of key fob is pressed	On
HI BEAM SW	Lighting switch OFF	Off
	Lighting switch HI	On
HEAD LAMP SW 1	Lighting switch OFF	Off
	Lighting switch 2ND	On
HEAD LAMP SW 2	Lighting switch OFF	Off
	Lighting switch 2ND	On
AUTO LIGHT SW	Lighting switch OFF	Off
	Lighting switch AUTO	On
PASSING SW	Other than lighting switch PASS	Off
	Lighting switch PASS	On
RR FOG SW	<b>NOTE:</b> The item is indicated, but not monitored.	Off
TURN SIGNAL R	Turn signal switch OFF	Off
	Turn signal switch RH	On
TURN SIGNAL L	Turn signal switch OFF	Off
	Turn signal switch LH	On
PKB SW	Parking brake switch is OFF	Off
	Parking brake switch is ON	On
ENGINE RUN	Engine stopped	Off
	Engine running	On
OPTI SEN (DTCT)	Bright outside of the vehicle	Close to 5 V
	Dark outside of the vehicle	Close to 0 V
OPTI SEN (FILT)	Bright outside of the vehicle (Lighting switch AUTO)	Close to 5 V
	Dark outside of the vehicle (Lighting switch AUTO)	Close to 1.50 V
LIG SEN COND	<b>NOTE:</b> The item is indicated, but not monitored.	OFF
IGN SW CAN	Ignition switch OFF or ACC	Off
	Ignition switch ON	On
FR WIPER HI	Front wiper switch OFF	Off
	Front wiper switch HI	On
FR WIPER LOW	Front wiper switch OFF	Off
	Front wiper switch LO	On
FR WIPER INT	Front wiper switch OFF	Off
	Front wiper switch INT	On
FR WASHER SW	Front washer switch OFF	Off
	Front washer switch ON	On
INT VOLUME	Wiper intermittent dial is in a dial position 1 - 7	1 - 7

# BCM (BODY CONTROL MODULE)

< ECU DIAGNOSIS INFORMATION >

[AUTOMATIC AIR CONDITIONING]

Monitor Item	Condition	Value/Status	
FR WIPER STOP	Any position other than front wiper stop position	Off	A
	Front wiper stop position	On	
RR WIPER ON	Rear wiper switch OFF	Off	B
	Rear wiper switch ON	On	
RR WIPER INT	Rear wiper switch OFF	Off	C
	Rear wiper switch INT	On	
RR WASHER SW	Rear washer switch OFF	Off	D
	Rear washer switch ON	On	
RR WIPER STOP	Rear wiper stop position	Off	E
	Other than rear wiper stop position	On	
RAIN SENSOR	<b>NOTE:</b> The item is indicated, but not monitored.	Off	E
HAZARD SW	Hazard switch OFF	Off	F
	Hazard switch ON	On	
FAN ON SIG	Blower control dial OFF	Off	G
	Other than blower control dial OFF	On	
AIR COND SW	<ul style="list-style-type: none"> <li>• Air conditioner OFF (A/C switch indicator OFF) (Automatic air conditioner)</li> <li>• A/C switch OFF (Manual air conditioner)</li> </ul>	Off	H
	<ul style="list-style-type: none"> <li>• Air conditioner ON (A/C switch indicator ON) (Automatic air conditioner)</li> <li>• A/C switch ON (Manual air conditioner)</li> </ul>	On	
THERMO AMP <b>NOTE:</b> At models with automatic air conditioner this item is not monitored.	Ignition switch ON	Off	HAC
	Evaporator is extremely low temperature	On	
FR DEF SW	Other than A/C mode defroster ON position	Off	J
	A/C mode defroster ON position	On	
KEYLESS TRUNK	<b>NOTE:</b> The item is indicated, but not monitored.	Off	K
TRNK OPNR SW	<b>NOTE:</b> The item is indicated, but not monitored.	Off	L
TRNK OPN MNTR	<b>NOTE:</b> The item is indicated, but not monitored.	Off	L
HOOD SW	Close the hood	Off	M
	Open the hood	On	
TRANSPONDER	Other than the ignition switch is ON by key registered to BCM.	Off	N
	The ignition switch is ON by key registered to BCM.	On	
INTELLI KEY	<b>NOTE:</b> The item is indicated, but not used.	Off	O
AUTO RELOCK	<b>NOTE:</b> The item is indicated, but not monitored.	Off	O
OIL PRESS SW	<ul style="list-style-type: none"> <li>• Ignition switch OFF or ACC</li> <li>• Engine running</li> </ul>	Off	P
	Ignition switch ON	On	
BRAKE SW	Brake pedal is not depressed	Off	P
	Brake pedal is depressed	On	

# BCM (BODY CONTROL MODULE)

< ECU DIAGNOSIS INFORMATION >

[AUTOMATIC AIR CONDITIONING]

## TERMINAL LAYOUT

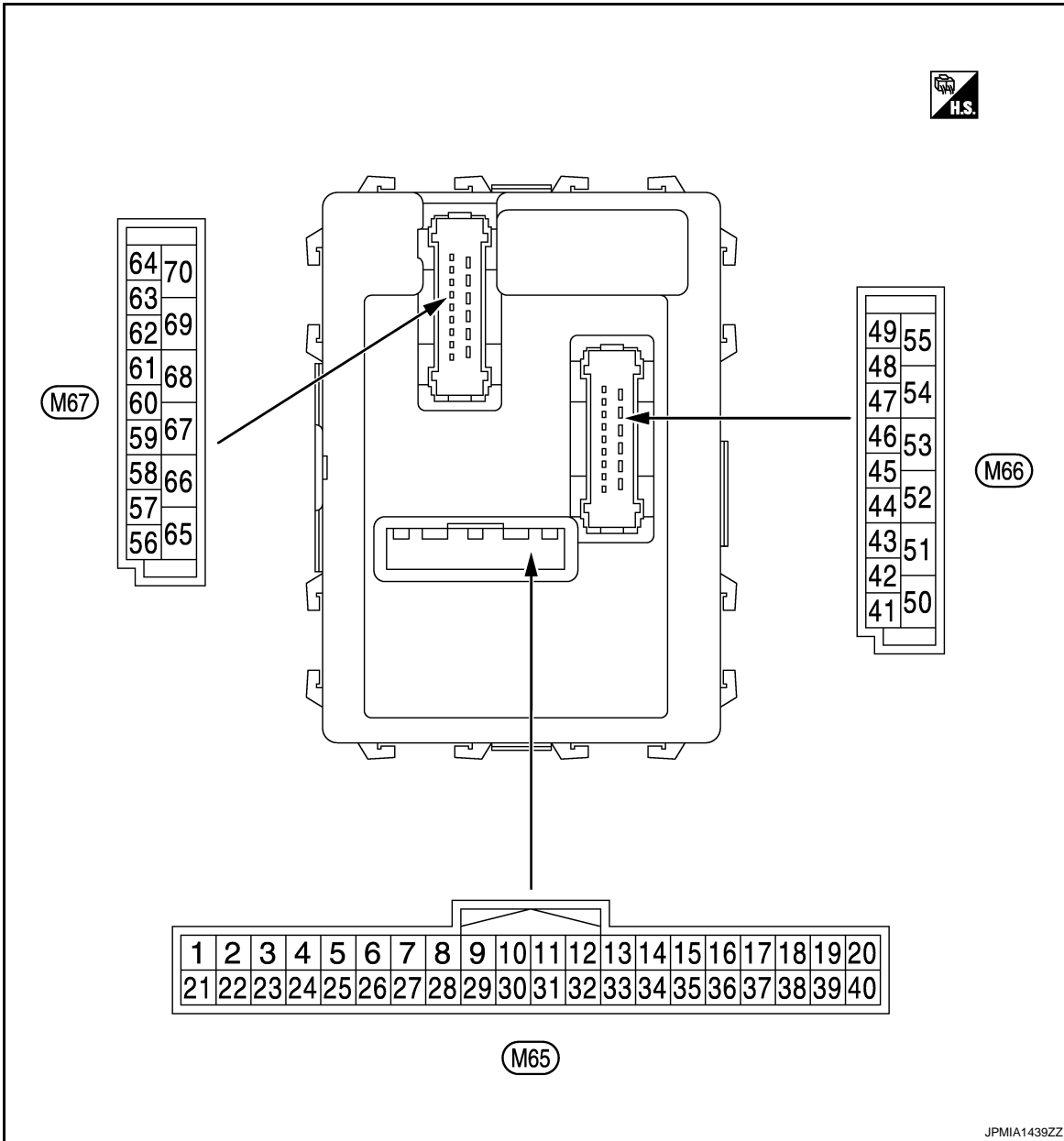

**NOTE:**

- M65, M66: White
- M67: Black

PHYSICAL VALUES

JPMIA1439ZZ

# BCM (BODY CONTROL MODULE)

< ECU DIAGNOSIS INFORMATION >

[AUTOMATIC AIR CONDITIONING]

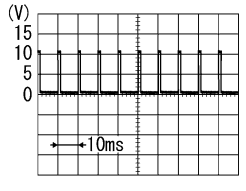
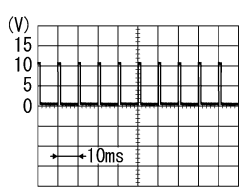
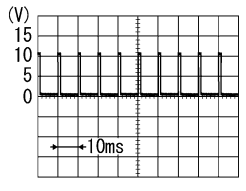
Terminal No. (Wire color)		Description		Condition	Value (Approx.)
		Signal name	Input/ Output		
+	-				
2 (BR/W)	Ground	Combination switch INPUT 5	Input	All switch OFF	0 V
				Turn signal switch RH	
				Lighting switch HI	
				Lighting switch 1ST	
				Lighting switch 2ND	
3 (GR)	Ground	Combination switch INPUT 4	Input	All switch OFF	0 V
				Turn signal switch LH	
				Lighting switch PASS	
				Lighting switch 2ND	
				Front fog lamp switch ON	
4 (L/Y)	Ground	Combination switch INPUT 3	Input	All switch OFF	0 V
				Front wiper switch LO	
				Front wiper switch MIST	
				Front wiper switch INT	
				Lighting switch AUTO	

A  
B  
C  
D  
E  
F  
G  
H  
HAC  
J  
K  
L  
M  
N  
O  
P

# BCM (BODY CONTROL MODULE)

< ECU DIAGNOSIS INFORMATION >

[AUTOMATIC AIR CONDITIONING]

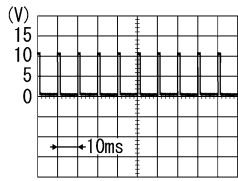
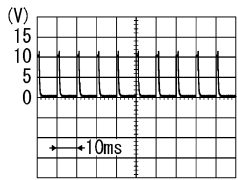
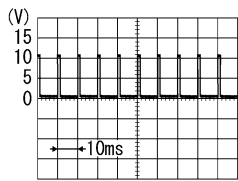
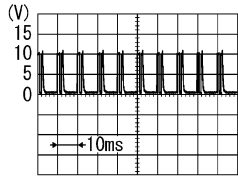
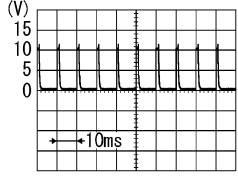
Terminal No. (Wire color)		Description		Condition	Value (Approx.)		
+	-	Signal name	Input/ Output				
5 (G)	Ground	Combination switch INPUT 2	Input	Combination switch	All switch OFF (Wiper intermittent dial 4)	0 V	
					Front washer switch (Wiper intermittent dial 4)	 <p style="text-align: right; font-size: small;">PKIB4958J</p>	
Rear washer switch ON (Wiper intermittent dial 4)	1.0 V						
Any of the condition below with all switch OFF	0.8 V						
					<ul style="list-style-type: none"> <li>• Wiper intermittent dial 1</li> <li>• Wiper intermittent dial 5</li> <li>• Wiper intermittent dial 6</li> </ul>		
				Rear wiper switch ON (Wiper intermittent dial 4)	 <p style="text-align: right; font-size: small;">PKIB4956J</p>		
6 (L/R)	Ground	Combination switch INPUT 1	Input	Combination switch	All switch OFF (Wiper intermittent dial 4)	0 V	
					Front wiper switch HI (Wiper intermittent dial 4)	 <p style="text-align: right; font-size: small;">PKIB4958J</p>	
					Rear wiper switch INT (Wiper intermittent dial 4)		1.0 V
					Wiper intermittent dial 3 (All switch OFF)		1.9 V
				Any of the condition below with all switch OFF	 <p style="text-align: right; font-size: small;">PKIB4952J</p>		
				<ul style="list-style-type: none"> <li>• Wiper intermittent dial 1</li> <li>• Wiper intermittent dial 2</li> </ul>	0.8 V		
				Any of the condition below with all switch OFF	 <p style="text-align: right; font-size: small;">PKIB4956J</p>		
				<ul style="list-style-type: none"> <li>• Wiper intermittent dial 6</li> <li>• Wiper intermittent dial 7</li> </ul>	0.8 V		

# BCM (BODY CONTROL MODULE)

< ECU DIAGNOSIS INFORMATION >

[AUTOMATIC AIR CONDITIONING]

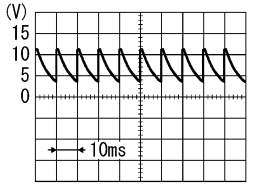
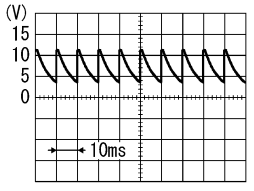
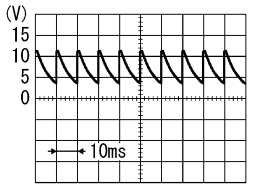
Terminal No. (Wire color)		Description		Condition	Value (Approx.)	
+	-	Signal name	Input/ Output			
7 (W/R)	Ground	Door key cylinder switch UNLOCK	Input	Door key cylinder switch	NEUTRAL position	 7.0 - 8.0 V
				UNLOCK position	0 V	
8 (W/B)	Ground	Door key cylinder switch LOCK	Input	Door key cylinder switch	NEUTRAL position	12 V
				LOCK position	0 V	
9 (R)	Ground	Stop lamp switch	Input	Stop lamp switch	OFF (Brake pedal is not depressed)	0 V
					ON (Brake pedal is de- pressed)	Battery voltage
10 (W/L)	Ground	Rear window defog- ger switch	Input	Rear window defogger switch	OFF (Not pressed)	12 V
					ON (Pressed)	0 V
11 (L/Y)	Ground	Ignition switch ACC	Input	Ignition switch OFF		0 V
				Ignition switch ACC or ON		Battery voltage
12 (SB)	Ground	Passenger door switch	Input	Passenger door switch	OFF (When passenger door closed)	 7.0 - 8.0 V
					ON (When passenger door opened)	0 V
13 (GR/L)	Ground	Rear RH door switch	Input	Rear RH door switch	OFF (When rear RH door closed)	 7.0 - 8.0 V
					ON (When rear RH door opened)	0 V
14 (L/B)	Ground	Optical sensor	Input	Ignition switch ON	When bright outside of the vehicle	Close to 5 V
					When dark outside of the vehicle	Close to 0 V

A  
B  
C  
D  
E  
F  
G  
H  
J  
K  
L  
M  
N  
O  
P

HAC

# BCM (BODY CONTROL MODULE)

< ECU DIAGNOSIS INFORMATION >

[AUTOMATIC AIR CONDITIONING]

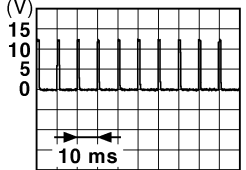
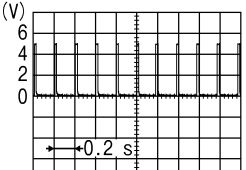
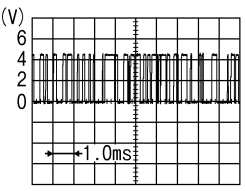
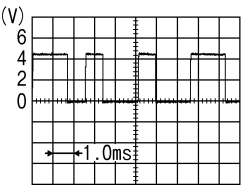
Terminal No. (Wire color)		Description		Condition		Value (Approx.)
+	-	Signal name	Input/ Output			
15 (V/W)	Ground	Tire pressure warning check switch	Input	Ignition switch OFF		 <small>JPMIA0012GB</small> 1.0 - 1.5 V
17 (R/G)	Ground	Optical sensor power supply	Output	Ignition switch	OFF, ACC	0 V
					ON	5 V
18 (V)	Ground	Receiver and sensor ground	Input	Ignition switch ON		0 V
19 (BR)	Ground	Remote keyless entry receiver power supply	Input	Ignition switch OFF	Insert mechanical key into ignition key cylinder	0 V
					Remove mechanical key from ignition key cylinder (Any door opened)	5 V
					Remove mechanical key from ignition key cylinder (Any door closed)	 <small>JPMIA0338JP</small>
20 (G/Y)	Ground	Remote keyless entry receiver communication	Input	Ignition switch OFF	Insert mechanical key into ignition key cylinder	0 V
					Waiting	 <small>PIIB7728J</small>
					Signal receiving	 <small>PIIB7729J</small>
21 (P/L)	Ground	Immobilizer antenna (Clock)	Input/ Output	During waiting	Ignition switch is pressed while inserting the key into the key slot.	Just after pressing ignition switch. Pointer of tester should move.



# BCM (BODY CONTROL MODULE)

< ECU DIAGNOSIS INFORMATION >

[AUTOMATIC AIR CONDITIONING]

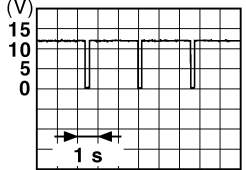
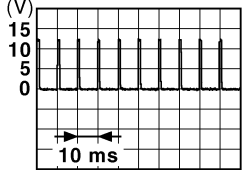
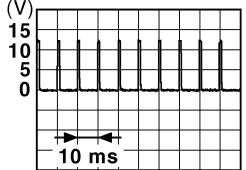
Terminal No. (Wire color)		Description		Condition	Value (Approx.)		
+	-	Signal name	Input/ Output				
23 (R/Y)	Ground	Security indicator	Input	Security indicator	ON	0 V	
				Blinking (Ignition switch OFF)	 <p style="text-align: right; font-size: small;">JPMIA0014GB</p>	11.3 V	
				OFF	12 V		
24 (GR/R)	Ground	Dongle link	Input/ Output	Ignition switch OFF	5 V		
25 (LG)	Ground	Immobilizer antenna (Rx, Tx)	Input/ Output	During waiting	Ignition switch is pressed while inserting the key into the key slot. Just after pressing ignition switch. Pointer of tester should move.		
26*1 (GR)	Ground	Thermo control amp.	Input	Ignition switch ON	0 V		
				Evaporator is extremely low temperature	12 V		
27 (Y/G)*2 (Y/R)*3	Ground	A/C switch (Automatic air conditioner)	Input	A/C	OFF (A/C switch indicator: OFF)	 <p style="text-align: right; font-size: small;">JPMIA0012GB</p>	1.0 - 1.5 V
					ON (A/C switch indicator: ON)	0 V	
			A/C switch (Manual air conditioner)	A/C switch	OFF	 <p style="text-align: right; font-size: small;">JPMIA0012GB</p>	1.0 - 1.5 V
				ON	0 V		

A  
B  
C  
D  
E  
F  
G  
H  
J  
K  
L  
M  
N  
O  
P

HAC

# BCM (BODY CONTROL MODULE)

< ECU DIAGNOSIS INFORMATION >

[AUTOMATIC AIR CONDITIONING]

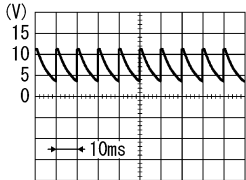
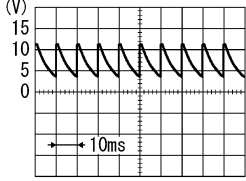
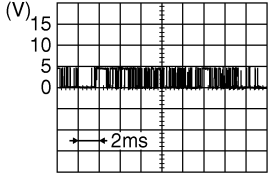
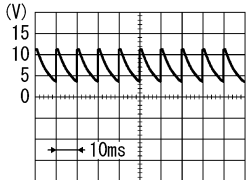
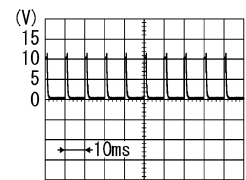
Terminal No. (Wire color)		Description		Condition	Value (Approx.)
+	-	Signal name	Input/ Output		
28 (G/W)	Ground	Blower fan switch (Automatic air conditioner)	Input	Blower fan switch OFF	0 V
				Blower fan switch ON	 <p style="text-align: right; font-size: small;">PKIB4960J</p>
		Blower fan switch (Manual air conditioner)	Fan switch	Blower fan switch OFF	 <p style="text-align: right; font-size: small;">PKIB4960J</p>
				Blower fan switch ON	0 V
29 (L/W)	Ground	Hazard switch	Input	Hazard switch OFF	Battery voltage
				Hazard switch ON	0 V
31 (G/Y)	Ground	Front defroster switch	Input	Ignition switch ON	0 V
				Other than A/C mode defroster ON position	 <p style="text-align: right; font-size: small;">JPMIA0589GB</p>
32 (LG)	Ground	Combination switch OUTPUT 5	Output	Combination switch	 <p style="text-align: right; font-size: small;">PKIB4960J</p>
				All switch OFF (Wiper intermittent dial 4)	 <p style="text-align: right; font-size: small;">PKIB4956J</p>
				Front fog lamp switch ON (Wiper intermittent dial 4) Rear wiper switch ON (Wiper intermittent dial 4) Any of the condition below with all switch OFF • Wiper intermittent dial 1 • Wiper intermittent dial 2 • Wiper intermittent dial 6 • Wiper intermittent dial 7	1.0 V

# BCM (BODY CONTROL MODULE)

< ECU DIAGNOSIS INFORMATION >

[AUTOMATIC AIR CONDITIONING]

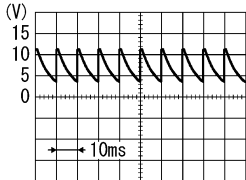
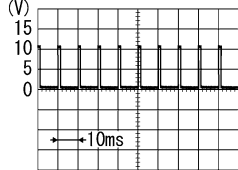
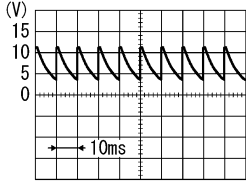
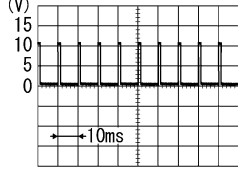
Terminal No. (Wire color)		Description		Condition	Value (Approx.)	
+	-	Signal name	Input/ Output			
33 (Y/L)	Ground	Combination switch OUTPUT 4	Output	Combination switch	All switch OFF (Wiper intermittent dial 4)	 7.0 - 8.0 V
				Lighting switch 1ST (Wiper intermittent dial 4)	 1.2 V	
				Lighting switch AUTO (Wiper intermittent dial 4)		
				Rear wiper switch INT (Wiper intermittent dial 4)		
				Any of the condition below with all switch OFF		
				<ul style="list-style-type: none"> <li>• Wiper intermittent dial 1</li> <li>• Wiper intermittent dial 5</li> <li>• Wiper intermittent dial 6</li> </ul>		
34 (W)	Ground	Combination switch OUTPUT 3	Output	Combination switch	All switch OFF (Wiper intermittent dial 4)	 7.0 - 8.0 V
				Lighting switch 2ND (Wiper intermittent dial 4)	 1.2 V	
				Lighting switch HI (Wiper intermittent dial 4)		
				Rear washer switch ON (Wiper intermittent dial 4)		
				Any of the condition below with all switch OFF		
				<ul style="list-style-type: none"> <li>• Wiper intermittent dial 1</li> <li>• Wiper intermittent dial 2</li> <li>• Wiper intermittent dial 3</li> </ul>		

A  
B  
C  
D  
E  
F  
G  
H  
I  
J  
K  
L  
M  
N  
O  
P

HAC

# BCM (BODY CONTROL MODULE)

< ECU DIAGNOSIS INFORMATION >

[AUTOMATIC AIR CONDITIONING]

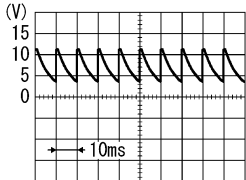
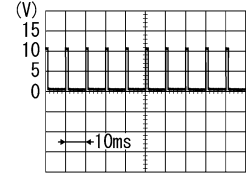
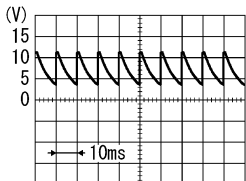
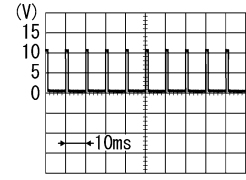
Terminal No. (Wire color)		Description		Condition	Value (Approx.)	
+	-	Signal name	Input/ Output			
35 (R/L)	Ground	Combination switch OUTPUT 2	Output	Combination switch (Wiper intermit- tent dial 4)	All switch OFF	 <small>PKIB4960J</small> 7.0 - 8.0 V
					Lighting switch 2ND	 <small>PKIB4958J</small> 1.2 V
					Lighting switch PASS	
					Front wiper switch INT	
				Front wiper switch HI		
36 (L/O)	Ground	Combination switch OUTPUT 1	Output	Combination switch (Wiper intermit- tent dial 4)	All switch OFF	 <small>PKIB4960J</small> 7.0 - 8.0 V
					Turn signal switch RH	 <small>PKIB4958J</small> 1.2 V
					Turn signal switch LH	
					Front wiper switch LO (Front wiper switch MIST)	
				Front washer switch ON		
37 (R/W)	Ground	Key switch	Input	Insert mechanical key into ignition key cylinder	Battery voltage	
				Remove mechanical key from ignition key cylinder	0 V	
38 (O)	Ground	Ignition switch ON	Input	Ignition switch OFF or ACC	0 V	
				Ignition switch ON	Battery voltage	
39 (L)	Ground	CAN-H	Input/ Output	—	—	
40 (P)	Ground	CAN-L	Input/ Output	—	—	

# BCM (BODY CONTROL MODULE)

< ECU DIAGNOSIS INFORMATION >

[AUTOMATIC AIR CONDITIONING]

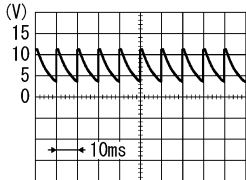
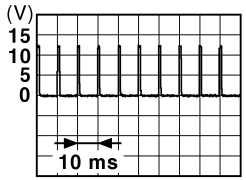
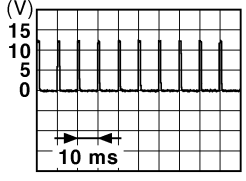
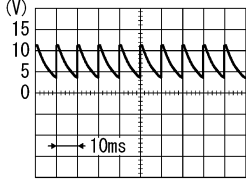
Terminal No. (Wire color)		Description		Condition	Value (Approx.)	
+	-	Signal name	Input/ Output			
43 (W)	Ground	Back door switch	Input	Back door switch	OFF (When back door closed)	 <small>PKIB4960J</small> 7.0 - 8.0 V
					ON (When back door opened)	0 V
44 (LG)	Ground	Rear wiper stop position	Input	Ignition switch ON	Rear wiper stop position	12 V
					Any position other than rear wiper stop position	0 V
45 (GR)	Ground	Door lock and unlock switch LOCK	Input	Door lock and unlock switch	NEUTRAL position	 <small>JPMIA0012GB</small> 1.0 - 1.5 V
					LOCK position	0 V
46 (BR)	Ground	Door lock and unlock switch UNLOCK	Input	Door lock and unlock switch	NEUTRAL position	 <small>JPMIA0012GB</small> 1.0 - 1.5 V
					UNLOCK position	0 V
47 (BR/Y)	Ground	Driver door switch	Input	Driver door switch	OFF (When driver door closed)	 <small>PKIB4960J</small> 7.0 - 8.0 V
					ON (When driver door opened)	0 V

A  
B  
C  
D  
E  
F  
G  
H  
HAC  
J  
K  
L  
M  
N  
O  
P

# BCM (BODY CONTROL MODULE)

< ECU DIAGNOSIS INFORMATION >

[AUTOMATIC AIR CONDITIONING]

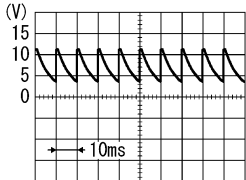
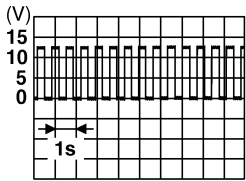
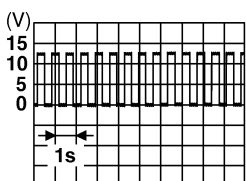
Terminal No. (Wire color)		Description		Condition	Value (Approx.)	
		Signal name	Input/ Output			
+	-					
48 (W/G)	Ground	Rear LH door switch	Input	Rear LH door switch	OFF (When rear LH door closed)	 <p style="text-align: right; font-size: small;">PKIB4960J</p>
					ON (When rear LH door opened)	0 V
50*1 (SB)	Ground	A/C indicator	Output	A/C indicator	OFF	12 V
					ON	0 V
54 (L/W)	Ground	Rear wiper	Output	Ignition switch ON	Rear wiper switch OFF	0 V
					Rear wiper switch ON	12 V
56 (L)	Ground	Interior room lamp power supply	Output	Interior room lamp battery saver is activated. (Cuts the interior room lamp power supply)		0 V
				Interior room lamp battery saver is not activated. (Outputs the interior room lamp power supply)		12 V
57 (Y)	Ground	Battery power supply	Input	Ignition switch OFF		Battery voltage
59 (L/B)	Ground	Driver door UNLOCK	Output	Driver door	UNLOCK (Actuator is activated)	12 V
					Other than UNLOCK (Actuator is not activated)	0 V
60 (W/B)	Ground	Turn signal LH	Output	Ignition switch ON	Turn signal switch OFF	0 V
					Turn signal switch LH	 <p style="text-align: right; font-size: small;">PKIC6370E</p>
61 (W/L)	Ground	Turn signal RH	Output	Ignition switch ON	Turn signal switch OFF	0 V
					Turn signal switch RH	 <p style="text-align: right; font-size: small;">PKIC6370E</p>
63 (BR)	Ground	Interior room lamp timer control	Output	Interior room lamp	OFF	12 V
					ON	0 V

# BCM (BODY CONTROL MODULE)

< ECU DIAGNOSIS INFORMATION >

[AUTOMATIC AIR CONDITIONING]

Terminal No. (Wire color)		Description		Condition		Value (Approx.)
+	-	Signal name	Input/ Output			
65 (V)	Ground	All doors LOCK	Output	All doors	LOCK (Actuator is activated)	12 V
					Other then LOCK (Actuator is not activated)	0 V
66 (G)	Ground	Passenger door and rear door UNLOCK	Output	Passenger door and rear door	UNLOCK (Actuator is activated)	12 V
					Other then UNLOCK (Actuator is not activated)	0 V
67 (B)	Ground	Ground	Output	Ignition switch ON		0 V
68 (L)	Ground	P/W power supply (IGN)	Output	Ignition switch ON		12 V
69 (L/W)	Ground	P/W power supply (BAT)	Output	Ignition switch OFF		12 V
70 (Y)	Ground	Battery power supply	Input	Ignition switch OFF		Battery voltage

- \*1: Only manual air conditioner
- \*2: Automatic air conditioner
- \*3: Manual air conditioner

BCM (BODY CONTROL SYSTEM) (WITHOUT INTELLIGENT KEY SYSTEM) : Wiring

A  
B  
C  
D  
E  
F  
G  
H  
J  
K  
L  
M  
N  
O  
P

HAC

# BCM (BODY CONTROL MODULE)

[AUTOMATIC AIR CONDITIONING]

< ECU DIAGNOSIS INFORMATION >

## Diagram - BCM -

INFOID:000000005819860

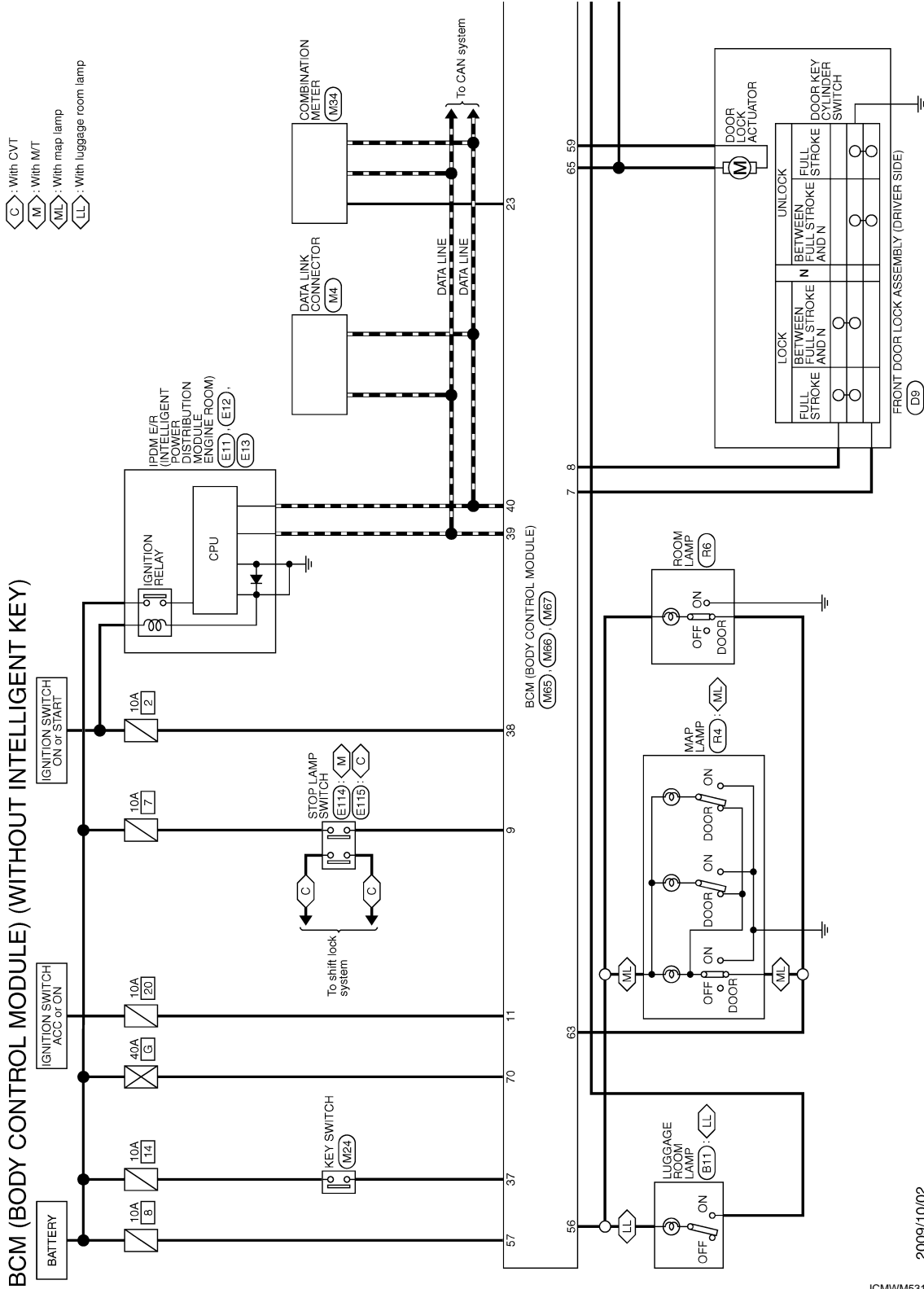

2009/10/02

JCMWM5310G



# BCM (BODY CONTROL MODULE)

< ECU DIAGNOSIS INFORMATION >

[AUTOMATIC AIR CONDITIONING]

AA: With auto A/C  
 MA: With manual A/C  
 AL: With auto light system

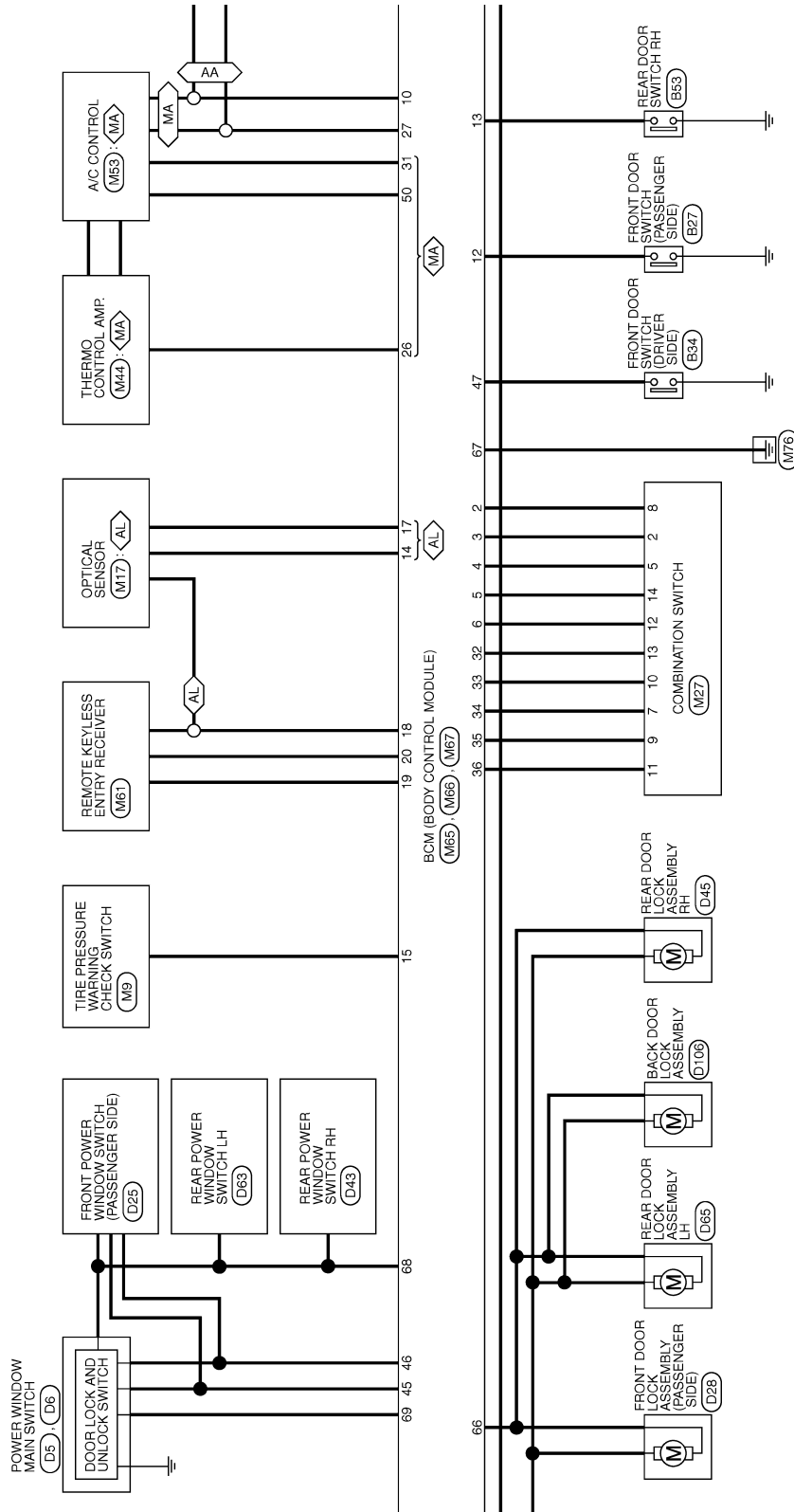

JCMWM5311GI

A  
 B  
 C  
 D  
 E  
 F  
 G  
 H  
**HAC**  
 J  
 K  
 L  
 M  
 N  
 O  
 P

# BCM (BODY CONTROL MODULE)

< ECU DIAGNOSIS INFORMATION >

[AUTOMATIC AIR CONDITIONING]

- : For Canada
- : With auto A/C
- : With manual A/C
- : With luggage room lamp

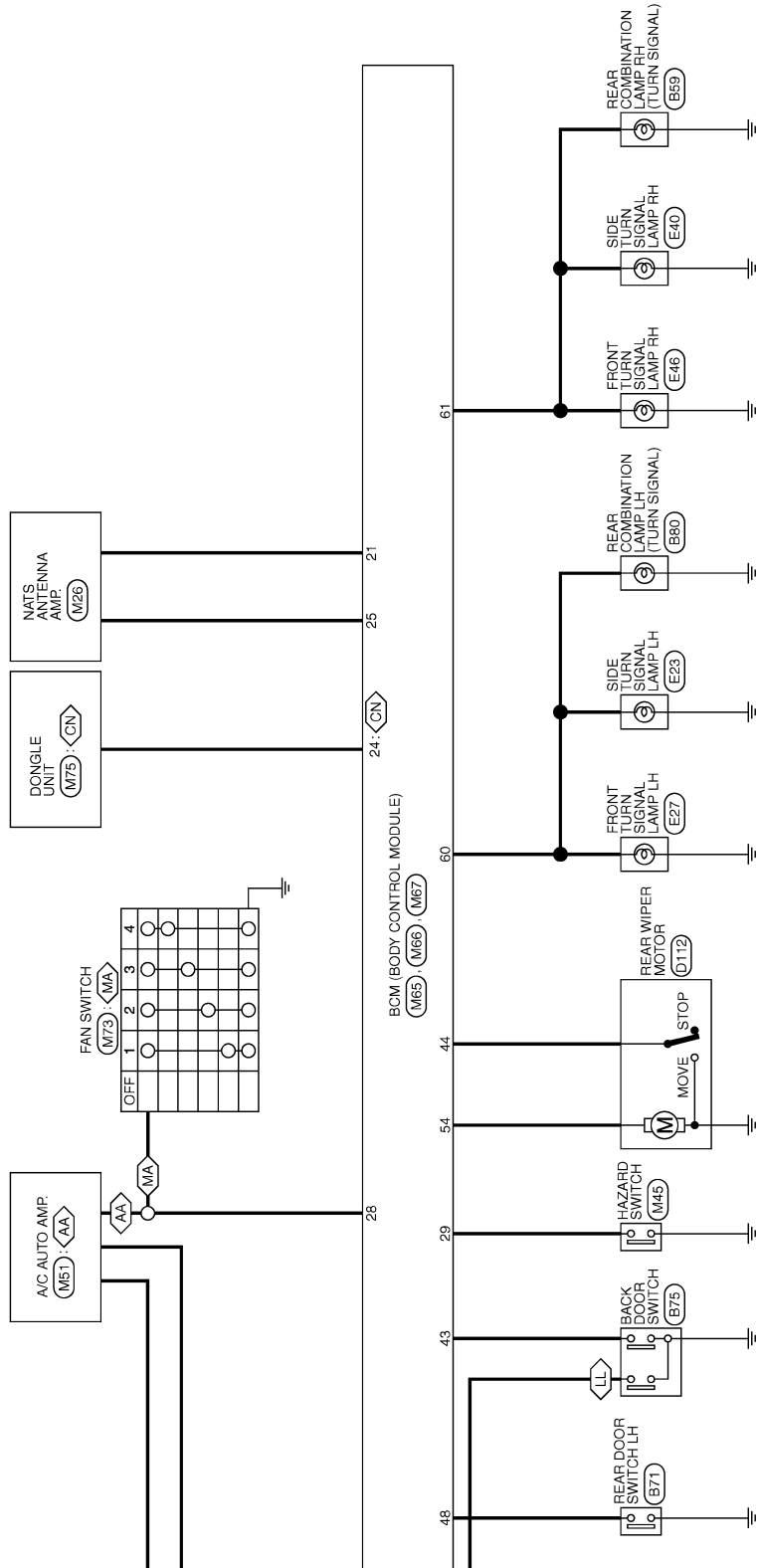

JCMWM5312G

# BCM (BODY CONTROL MODULE)

< ECU DIAGNOSIS INFORMATION >

[AUTOMATIC AIR CONDITIONING]

**BCM (BODY CONTROL MODULE) (WITHOUT INTELLIGENT KEY)**

Connector No.	M27
Connector Name	COMBINATION SWITCH
Connector Type	TH16FW-NH



Terminal No.	Color of Wire	Signal Name [Specification]
1	O	WASHER (RR)
2	GR	INPUT 4
3	L	WASHER (FR)
4	W	IGN
5	L/Y	INPUT 3
6	B	GND
7	W	OUTPUT 3
8	BR/W	INPUT 5
9	R/L	OUTPUT 2
10	Y/L	OUTPUT 4
11	L/O	OUTPUT 1
12	L/R	INPUT 1
13	LG	OUTPUT 5
14	G	INPUT 2

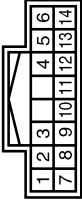

Connector No.	M67
Connector Name	BCM (BODY CONTROL MODULE)
Connector Type	FEA08FB-FH46-SA



Terminal No.	Color of Wire	Signal Name [Specification]
56	L	INTERIOR ROOM LAMP POWER SUPPLY
57	Y	BAT (FUSE)
58	L/B	DRIVER DOOR UNLOCK OUTPUT
60	W/B	TURN SIGNAL LH OUTPUT
61	W/L	TURN SIGNAL RH OUTPUT
63	BR	ROOM LAMP-TIMER CONTROL
65	V	ALL DOOR LOCK OUTPUT
66	G	PASSENGER DOOR, REAR DOOR UNLOCK OUTPUT
67	B	GND
68	L	POWER WINDOW POWER SUPPLY (IGN)
69	L/W	POWER WINDOW POWER SUPPLY (BAT)
70	Y	BAT (F/L)

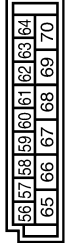

**BCM (BODY CONTROL MODULE) (WITHOUT INTELLIGENT KEY)**

10	W/L	REAR WINDOW DEFROGGER SW
11	L/Y	ACC
12	SS	PASSENGER DOOR SW
13	GR/L	REAR RH DOOR SW
14	L/B	OPTICAL SENSOR
15	W/W	TIRE PRESS WARNING CHECK SW
17	R/G	OPTICAL SENSOR POWER SUPPLY
18	V	RECEIVER/SENSOR GND
19	BR	KEYLESS ENTRY RECEIVER POWER SUPPLY
20	G/Y	KEYLESS ENTRY RECEIVER COMM
21	P/L	NATS ANTENNA AMP
23	R/Y	SECURITY INDICATOR LAMP
24	GR/R	DONGLE LINK
25	LG	NATS ANTENNA AMP
26	GR	THERMO CONTROL AMP
27	Y/G	A/C SW (With auto A/C)
27	Y/R	A/C SW (With manual A/C)
28	G/W	BLOWER FAN SW
29	L/W	HAZARD SW
31	G/Y	FR DEFROSTER SW
32	LG	COMBI SW OUTPUT 5
33	Y/L	COMBI SW OUTPUT 4
34	W	COMBI SW OUTPUT 3
35	R/L	COMBI SW OUTPUT 2
36	L/O	COMBI SW OUTPUT 1
37	R/W	KEY SWITCH
38	O	IGN
39	L	CAN-H
40	P	CAN-L



Connector No.	M66
Connector Name	BCM (BODY CONTROL MODULE)
Connector Type	FEA08FW-FH46-SA



Terminal No.	Color of Wire	Signal Name [Specification]
41	W	BACK DOOR SW
43	W	REAR WIPER STOP POSITION
44	LG	CENTRAL DOOR LOCK SW
45	GR	CENTRAL DOOR UNLOCK SW
46	BR	DRIVER DOOR SW
47	BR/Y	REAR LH DOOR SW
48	W/G	A/C INDICATOR OUTPUT
50	SB	A/C INDICATOR OUTPUT

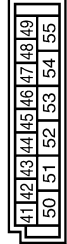

## BCM (BODY CONTROL SYSTEM) (WITHOUT INTELLIGENT KEY SYSTEM) : Fail-safe

FAIL-SAFE CONTROL BY DTC  
 BCM performs fail-safe control when any DTC are detected.

JCMWM5313G  
 INFOID:000000005819861

A  
B  
C  
D  
E  
F  
G  
H  
HAC  
J  
K  
L  
M  
N  
O  
P

# BCM (BODY CONTROL MODULE)

< ECU DIAGNOSIS INFORMATION >

[AUTOMATIC AIR CONDITIONING]

Display contents of CONSULT	Fail-safe	Cancellation
B2190: NATS ANTENNA AMP	Inhibit engine cranking	Erase DTC
B2191: DIFFERENCE OF KEY	Inhibit engine cranking	Erase DTC
B2192: ID DISCORD BCM-ECM	Inhibit engine cranking	Erase DTC
B2193: CHAIN OF BCM-ECM	Inhibit engine cranking	Erase DTC
B2195: ANTI SCANNING	Inhibit engine cranking	Ignition switch ON → OFF
B2196: DONGLE NG	Inhibit engine cranking	Erase DTC

## REAR WIPER MOTOR PROTECTION

BCM detects the rear wiper stopping position according to the rear wiper auto stop signal.

When the rear wiper auto stop signal does not change more than 5 seconds while driving the rear wiper, BCM stops power supply to protect the rear wiper motor.

Condition of cancellation

1. Pass more than 1 minute after the rear wiper stop.
2. Turn rear wiper switch OFF.
3. Operate the rear wiper switch or rear washer switch.

## BCM (BODY CONTROL SYSTEM) (WITHOUT INTELLIGENT KEY SYSTEM) : DTC Inspection Priority Chart

INFOID:000000005819862

If some DTCs are displayed at the same time, perform inspections one by one based on the following priority chart.

Priority	DTC
1	<ul style="list-style-type: none"><li>• U1000: CAN COMM</li><li>• U1010: CONTROL UNIT (CAN)</li></ul>
2	<ul style="list-style-type: none"><li>• B2190: NATS ANTENNA AMP</li><li>• B2191: DIFFERENCE OF KEY</li><li>• B2192: ID DISCORD BCM-ECM</li><li>• B2193: CHAIN OF BCM-ECM</li><li>• B2195: ANTI SCANNING</li><li>• B2196: DONGLE NG</li></ul>
3	C1735: IGN CIRCUIT OPEN
4	<ul style="list-style-type: none"><li>• C1704: LOW PRESSURE FL</li><li>• C1705: LOW PRESSURE FR</li><li>• C1706: LOW PRESSURE RR</li><li>• C1707: LOW PRESSURE RL</li><li>• C1708: [NO DATA] FL</li><li>• C1709: [NO DATA] FR</li><li>• C1710: [NO DATA] RR</li><li>• C1711: [NO DATA] RL</li><li>• C1716: [PRESSDATA ERR] FL</li><li>• C1717: [PRESSDATA ERR] FR</li><li>• C1718: [PRESSDATA ERR] RR</li><li>• C1719: [PRESSDATA ERR] RL</li><li>• C1729: VHCL SPEED SIG ERR</li><li>• C1734: CONTROL UNIT</li></ul>

## BCM (BODY CONTROL SYSTEM) (WITHOUT INTELLIGENT KEY SYSTEM) : DTC Index

INFOID:000000005819863

### NOTE:

- Details of time display
- CRNT: Displays when there is a malfunction now or after returning to the normal condition until turning ignition switch OFF → ON again.
  - 1 - 39: Displayed if any previous malfunction is present when current condition is normal. It increases like 1 → 2 → 3...38 → 39 after returning to the normal condition whenever ignition switch OFF → ON. The counter

## BCM (BODY CONTROL MODULE)

< ECU DIAGNOSIS INFORMATION >

[AUTOMATIC AIR CONDITIONING]

remains at 39 even if the number of cycles exceeds it. It is counted from 1 again when turning ignition switch OFF → ON after returning to the normal condition if the malfunction is detected again.

CONSULT display	Fail-safe	Tire pressure monitor warning lamp ON	Reference
U1000: CAN COMM	—	—	<a href="#">BCS-115</a>
U1010: CONTROL UNIT (CAN)	—	—	<a href="#">BCS-116</a>
B2190: NATS ANTENNA AMP	×	—	<a href="#">SEC-219</a>
B2191: DIFFERENCE OF KEY	×	—	<a href="#">SEC-222</a>
B2192: ID DISCORD BCM-ECM	×	—	<a href="#">SEC-223</a>
B2193: CHAIN OF BCM-ECM	×	—	<a href="#">SEC-225</a>
B2195: ANTI SCANNING	×	—	<a href="#">SEC-226</a>
B2196: DONGLE NG	×	—	<a href="#">SEC-227</a>
C1704: LOW PRESSURE FL	—	×	<a href="#">WT-30</a>
C1705: LOW PRESSURE FR	—	×	
C1706: LOW PRESSURE RR	—	×	
C1707: LOW PRESSURE RL	—	×	
C1708: [NO DATA] FL	—	×	<a href="#">WT-32</a>
C1709: [NO DATA] FR	—	×	
C1710: [NO DATA] RR	—	×	
C1711: [NO DATA] RL	—	×	
C1716: [PRESS DATA ERR] FL	—	×	<a href="#">WT-35</a>
C1717: [PRESS DATA ERR] FR	—	×	
C1718: [PRESS DATA ERR] RR	—	×	
C1719: [PRESS DATA ERR] RL	—	×	
C1729: VHCL SPEED SIG ERR	—	×	<a href="#">WT-37</a>
C1734: CONTROL UNIT	—	×	<a href="#">WT-39</a>
C1735: IGN CIRCUIT OPEN	—	—	<a href="#">BCS-117</a>

A  
B  
C  
D  
E  
F  
G  
H  
HAC  
J  
K  
L  
M  
N  
O  
P

# AUTOMATIC AIR CONDITIONING SYSTEM

< SYMPTOM DIAGNOSIS >

[AUTOMATIC AIR CONDITIONING]

## SYMPTOM DIAGNOSIS

### AUTOMATIC AIR CONDITIONING SYSTEM

#### Diagnosis Chart By Symptom

INFOID:000000005490091

**CAUTION:**

**Perform the self-diagnoses with on board diagnosis and CONSULT-III before performing the symptom diagnosis. If any malfunction result or DTC is detected, perform the corresponding diagnosis.**

Symptom	Corresponding malfunction part	Check item/Reference	
A/C system does not activate.	<ul style="list-style-type: none"> <li>• Power supply circuit of A/C system</li> <li>• A/C control (built-in A/C auto amp.)</li> </ul>	<a href="#">HAC-66. "A/C AUTO AMP. : Diagnosis Procedure"</a>	
A/C system cannot be controlled.			
Blower motor operation is malfunctioning.	<ul style="list-style-type: none"> <li>• Blower motor</li> <li>• Power supply system of blower motor</li> <li>• The circuit between blower motor and A/C auto amp.</li> <li>• A/C auto amp.</li> </ul>	<a href="#">HAC-56. "Diagnosis Procedure"</a>	
Magnet clutch does not operate.	<ul style="list-style-type: none"> <li>• Magnet clutch</li> <li>• The circuit between magnet clutch and IPDM E/R</li> <li>• IPDM E/R (A/C relay)</li> <li>• The circuit between ECM and refrigerant pressure sensor</li> <li>• Refrigerant pressure sensor</li> <li>• CAN communication line</li> <li>• A/C auto amp.</li> </ul>	<a href="#">HAC-61. "Diagnosis Procedure"</a>	
<ul style="list-style-type: none"> <li>• Insufficient cooling</li> <li>• No cool air comes out. (Air flow volume is normal.)</li> </ul>	<ul style="list-style-type: none"> <li>• Magnet clutch control system</li> <li>• Drive belt slipping</li> <li>• Cooler cycle</li> <li>• Air leakage from each duct</li> <li>• Temperature setting trimmer</li> </ul>	<a href="#">HAC-135. "Diagnosis Procedure"</a>	
<ul style="list-style-type: none"> <li>• Insufficient heating</li> <li>• No warm air comes out. (Air flow volume is normal.)</li> </ul>	<ul style="list-style-type: none"> <li>• Engine cooling system</li> <li>• Heater hose</li> <li>• Heater core</li> <li>• Air leakage from each duct</li> <li>• Temperature setting trimmer</li> </ul>	<a href="#">HAC-137. "Diagnosis Procedure"</a>	
Noise is heard when the A/C system operates.	During compressor operation	<ul style="list-style-type: none"> <li>• Cooler cycle</li> </ul>	<a href="#">HA-10. "Symptom Table"</a>
	During blower motor operation	<ul style="list-style-type: none"> <li>• Mixing any foreign object in blower motor</li> <li>• Blower motor fan breakage</li> <li>• Blower motor rotation inferiority</li> </ul>	<a href="#">HAC-59. "Component Inspection"</a>
<ul style="list-style-type: none"> <li>• Memory function dose not operates.</li> <li>• Setting temperature dose not memorize.</li> </ul>	<ul style="list-style-type: none"> <li>• Power supply system of A/C auto amp.</li> <li>• A/C auto amp.</li> </ul>	<a href="#">HAC-140. "Inspection Procedure"</a>	

# INSUFFICIENT COOLING

< SYMPTOM DIAGNOSIS >

[AUTOMATIC AIR CONDITIONING]

## INSUFFICIENT COOLING

### Description

INFOID:000000005490092

#### Symptom

- Insufficient cooling
- No cool air comes out. (Air flow volume is normal.)

### Diagnosis Procedure

INFOID:000000005490093

#### **CAUTION:**

**Perform the self-diagnoses with on board diagnosis and CONSULT-III before performing symptom diagnosis. If any malfunction result or DTC is detected, perform the corresponding diagnosis.**

#### 1. CHECK MAGNET CLUTCH OPERATION

1. Turn the ignition switch ON.
2. Operate the fan control switch.
3. Press the A/C switch.
4. Check that the indicator of the A/C switch turns ON. Check visually and by sound that the compressor operates.
5. Press the A/C switch again.
6. Check that the indicator of the A/C switch turns OFF. Check that the compressor stops.

#### Is the inspection result normal?

YES >> GO TO 2.

NO >> Perform the diagnosis of "COMPRESSOR DOSE NOT OPERATE" in "SYMPTOM DIAGNOSIS".  
Refer to [HAC-138. "Diagnosis Procedure"](#).

#### 2. CHECK DRIVE BELT

Check tension of the drive belt. Refer to [EM-13. "Checking"](#).

#### Is the inspection result normal?

YES >> GO TO 3.

NO >> Adjust or replace drive belt depending on the inspection results.

#### 3. CHECK REFRIGERANT CYCLE PRESSURE

Connect the recovery/recycling recharging equipment to the vehicle and perform the pressure inspection with the gauge. Refer to [HA-8. "Symptom Table"](#).

#### Is the inspection result normal?

YES >> GO TO 4.

NO >> Repair or replace the parts depending on the inspection results.

#### 4. CHECK AIR LEAKAGE FROM EACH DUCT

Check duct and nozzle, etc. of the air conditioner system for leakage.

#### Is the inspection result normal?

YES >> GO TO 5.

NO >> Repair or replace parts depending on the inspection results.

#### 5. CHECK AMBIENT TEMPERATURE DISPLAY

Check that there is not much difference between actual ambient temperature and indicated temperature on information display in combination meter.

#### **NOTE:**

Actual ambient temperature is sensor recognition temperature of on board self-diagnosis STEP-5.

#### Is the inspection result normal?

YES >> GO TO 6.

NO >> Perform the diagnosis for the A/C auto amp. connection recognition signal. Refer to [MWI-48. "Diagnosis Procedure"](#).

#### 6. CHECK SETTING OF TEMPERATURE SETTING TRIMMER

1. Check the setting value of temperature setting trimmer. Refer to [HAC-10. "Temperature Setting Trimmer"](#).

## INSUFFICIENT COOLING

< SYMPTOM DIAGNOSIS >

[AUTOMATIC AIR CONDITIONING]

---

2. Check that the temperature setting trimmer is set to "+ direction".

**NOTE:**

The control temperature can be set with the setting of the temperature setting trimmer.

3. Set the difference between the set temperature and control temperature to "0".

Is inspection result normal?

YES >> INSPECTION END

NO >> Replace the A/C auto amp.



# INSUFFICIENT HEATING

< SYMPTOM DIAGNOSIS >

[AUTOMATIC AIR CONDITIONING]

## INSUFFICIENT HEATING

### Description

INFOID:000000005490094

#### Symptom

- Insufficient heating
- No warm air comes out. (Air flow volume is normal.)

### Diagnosis Procedure

INFOID:000000005490095

#### **CAUTION:**

**Perform the self-diagnoses with on board diagnosis and CONSULT-III before performing symptom diagnosis. If any malfunction result or DTC is detected, perform the corresponding diagnosis.**

#### 1. CHECK COOLING SYSTEM

1. Check the engine coolant level and check for leakage. Refer to [CO-9, "Inspection"](#).
2. Check the radiator cap. Refer to [CO-12, "RADIATOR CAP : Inspection"](#).
3. Check the water flow sounds of the engine coolant. Refer to [CO-10, "Refilling"](#).

Is the inspection result normal?

YES >> GO TO 2.

NO >> Refill the engine coolant and repair or replace the parts depending on the inspection results.

#### 2. CHECK HEATER HOSE

Check the installation of heater hose by visually or touching.

Is the inspection result normal?

YES >> GO TO 3.

NO >> Repair or replace parts depending on the inspection results.

#### 3. CHECK HEATER CORE

1. Check the temperature of inlet hose and outlet hose of heater core.
2. Check that the inlet side of heater core is hot and the outlet side is slightly lower than/almost equal to the inlet side.

#### **CAUTION:**

**Always perform the temperature inspection in a short period of time because the engine coolant temperature is very hot.**

Is the inspection result normal?

YES >> GO TO 4.

NO >> Replace the heater core. Refer to [HA-40, "Exploded View \(Automatic Air Conditioner\)"](#).

#### 4. CHECK AIR LEAKAGE FROM EACH DUCT

Check duct and nozzle, etc. of the air conditioner system for air leakage.

Is the inspection result normal?

YES >> GO TO 5.

NO >> Repair or replace parts depending on the inspection results.

#### 5. CHECK SETTING OF TEMPERATURE SETTING TRIMMER

1. Check the setting value of temperature setting trimmer. Refer to [HAC-10, "Temperature Setting Trimmer"](#).
2. Check that the temperature setting trimmer is set to "– direction".

#### **NOTE:**

The control temperature can be set by the temperature setting trimmer.

3. Set the difference between the set temperature and control temperature to "0".

Are the symptoms solved?

YES >> INSPECTION END

NO >> Replace the A/C auto amp.

A  
B  
C  
D  
E  
F  
G  
H  
J  
K  
L  
M  
N  
O  
P

HAC

# COMPRESSOR DOSE DOT OPERATE

[AUTOMATIC AIR CONDITIONING]

< SYMPTOM DIAGNOSIS >

## COMPRESSOR DOSE DOT OPERATE

### Description

INFOID:000000005490096

### SYMPTOM

Compressor dose not operate.

### Diagnosis Procedure

INFOID:000000005490097

#### CAUTION:

- Perform the self-diagnoses with on board diagnosis and CONSULT-III before performing symptom diagnosis. If any malfunction result or DTC is detected, perform the corresponding diagnosis.
- Check that the refrigerant is enclosed in cooler cycle normally. If the refrigerant amount is shortage from proper amount, perform the inspection of refrigerant leakage.

#### 1. CHECK MAGNET CLUTCH OPERATION

Check the magnet clutch. Refer to [HAC-61, "Component Function Check"](#).

Does it operate normally?

YES >> GO TO 2.

NO >> Repair or replace the malfunctioning parts.

#### 2. CHECK REFRIGERANT PRESSURE SENSOR

Check the refrigerant pressure sensor. Refer to [EC-415, "Diagnosis Procedure"](#).

Is the inspection result normal?

YES >> GO TO 3.

NO >> Repair or replace the malfunctioning parts.

#### 3. CHECK BCM INPUT SIGNAL

Ⓜ With CONSULT-III

Check the "COMP REQ SIG" or "FAN REQ SW" in "DATA MONITOR" of BCM.

Monitor item	Condition	Status
COMP REQ SIG	A/C switch: OFF	Off
	A/C switch: ON	On
FAN REQ SW	Fan control switch: OFF	Off
	Fan control switch: ON	On

Is the inspection result normal?

YES >> GO TO 4.

NO >> GO TO 5.

#### 4. CHECK BCM OUTPUT SIGNAL

Ⓜ With CONSULT-III

Check the "A/C ON SIG" or "FAN ON SIG" in "A/C RELAY SIG" of ECM.

Monitor item	Condition	Status
COMP REQ SIG	A/C switch: OFF	Off
	A/C switch: ON	On
FAN REQ SW	Fan control switch: OFF	Off
	Fan control switch: ON	On

Is the inspection result normal?

YES >> Replace the IPDM E/R. Refer to [PCS-34, "Exploded View"](#) (WITH I-KEY) or [PCS-64, "Exploded View"](#) (WITHOUT I-KEY).

NO >> Replace the BCM. Refer to [BCS-81, "Exploded View"](#) (WITH I-KEY) or [BCS-146, "Exploded View"](#) (WITHOUT I-KEY).

# COMPRESSOR DOSE DOT OPERATE

[AUTOMATIC AIR CONDITIONING]

< SYMPTOM DIAGNOSIS >

## 5.CHECK A/C ON SIGNAL

Check the A/C ON signal. Refer to [HAC-62, "Component Function Check"](#).

Is inspection result normal?

YES >> GO TO 6.

NO >> Repair or replace the malfunctioning parts.

## 6.CHECK BLOWER FAN ON SIGNAL

Check the blower fan ON signal. Refer to [HAC-64, "Component Function Check"](#).

Is the inspection result normal?

YES >> Replace the A/C auto amp.

NO >> Repair or replace the malfunctioning parts

A  
B  
C  
D  
E  
F  
G  
H  
J  
K  
L  
M  
N  
O  
P

HAC

# MEMORY FUNCTION DOES NOT OPERATE

< SYMPTOM DIAGNOSIS >

[AUTOMATIC AIR CONDITIONING]

## MEMORY FUNCTION DOES NOT OPERATE

### Description

INFOID:000000005490098

### SYMPTOM

- Memory function dose not operate normally.
- The setting is not maintained (It returns to initial condition).

### Inspection Procedure

INFOID:000000005490099

#### 1.CHECK MEMORY FUNCTION

---

1. Start the engine.
2. Set the temperature to 32°C (90°F) by operating the temperature control switch.
3. Press OFF switch.
4. Turn the ignition switch OFF.
5. Turn the ignition switch ON.
6. Press AUTO switch.
7. Check that the set temperature is maintained.

#### Is the inspection result normal?

- YES >> INSPECTION END  
NO >> GO TO 2.

#### 2.CHECK POWER SUPPLY AND GROUND CIRCUIT OF A/C AUTO AMP.

---

Check power supply and ground circuit of A/C auto amp. Refer to [HAC-70. "Diagnosis Procedure"](#).

#### Is the inspection result normal?

- YES >> Replace the A/C auto amp.  
NO >> Repair or replace the malfunctioning parts.

PRECAUTION

PRECAUTIONS

Precaution for Supplemental Restraint System (SRS) "AIR BAG" and "SEAT BELT PRE-TENSIONER"

INFOID:000000005490100

The Supplemental Restraint System such as "AIR BAG" and "SEAT BELT PRE-TENSIONER", used along with a front seat belt, helps to reduce the risk or severity of injury to the driver and front passenger for certain types of collision. This system includes seat belt switch inputs and dual stage front air bag modules. The SRS system uses the seat belt switches to determine the front air bag deployment, and may only deploy one front air bag, depending on the severity of a collision and whether the front occupants are belted or unbelted. Information necessary to service the system safely is included in the "SRS AIR BAG" and "SEAT BELT" of this Service Manual.

**WARNING:**

- To avoid rendering the SRS inoperative, which could increase the risk of personal injury or death in the event of a collision which would result in air bag inflation, all maintenance must be performed by an authorized NISSAN/INFINITI dealer.
- Improper maintenance, including incorrect removal and installation of the SRS, can lead to personal injury caused by unintentional activation of the system. For removal of Spiral Cable and Air Bag Module, see the "SRS AIR BAG".
- Do not use electrical test equipment on any circuit related to the SRS unless instructed to in this Service Manual. SRS wiring harnesses can be identified by yellow and/or orange harnesses or harness connectors.

PRECAUTIONS WHEN USING POWER TOOLS (AIR OR ELECTRIC) AND HAMMERS

**WARNING:**

- When working near the Air Bag Diagnosis Sensor Unit or other Air Bag System sensors with the ignition ON or engine running, DO NOT use air or electric power tools or strike near the sensor(s) with a hammer. Heavy vibration could activate the sensor(s) and deploy the air bag(s), possibly causing serious injury.
- When using air or electric power tools or hammers, always switch the ignition OFF, disconnect the battery, and wait at least 3 minutes before performing any service.

Precaution Necessary for Steering Wheel Rotation after Battery Disconnect

INFOID:000000005490101

**NOTE:**

- Before removing and installing any control units, first turn the push-button ignition switch to the LOCK position, then disconnect both battery cables.
- After finishing work, confirm that all control unit connectors are connected properly, then re-connect both battery cables.
- Always use CONSULT-III to perform self-diagnosis as a part of each function inspection after finishing work. If a DTC is detected, perform trouble diagnosis according to self-diagnosis results.

For vehicle with steering lock unit, if the battery is disconnected or discharged, the steering wheel will lock and cannot be turned.

If turning the steering wheel is required with the battery disconnected or discharged, follow the operation procedure below before starting the repair operation.

OPERATION PROCEDURE

1. Connect both battery cables.

**NOTE:**

Supply power using jumper cables if battery is discharged.

2. Turn the push-button ignition switch to ACC position.  
(At this time, the steering lock will be released.)
3. Disconnect both battery cables. The steering lock will remain released with both battery cables disconnected and the steering wheel can be turned.
4. Perform the necessary repair operation.

A  
B  
C  
D  
E  
F  
G  
H  
J  
K  
L  
M  
N  
O  
P

HAC

## PRECAUTIONS

< PRECAUTION >

[AUTOMATIC AIR CONDITIONING]

---

5. When the repair work is completed, re-connect both battery cables. With the brake pedal released, turn the push-button ignition switch from ACC position to ON position, then to LOCK position. (The steering wheel will lock when the push-button ignition switch is turned to LOCK position.)
6. Perform self-diagnosis check of all control units using CONSULT-III.

# A/C CONTROL (A/C AUTO AMP.)

< REMOVAL AND INSTALLATION >

[AUTOMATIC AIR CONDITIONING]

## REMOVAL AND INSTALLATION

### A/C CONTROL (A/C AUTO AMP.)

Exploded View

INFOID:000000005490102

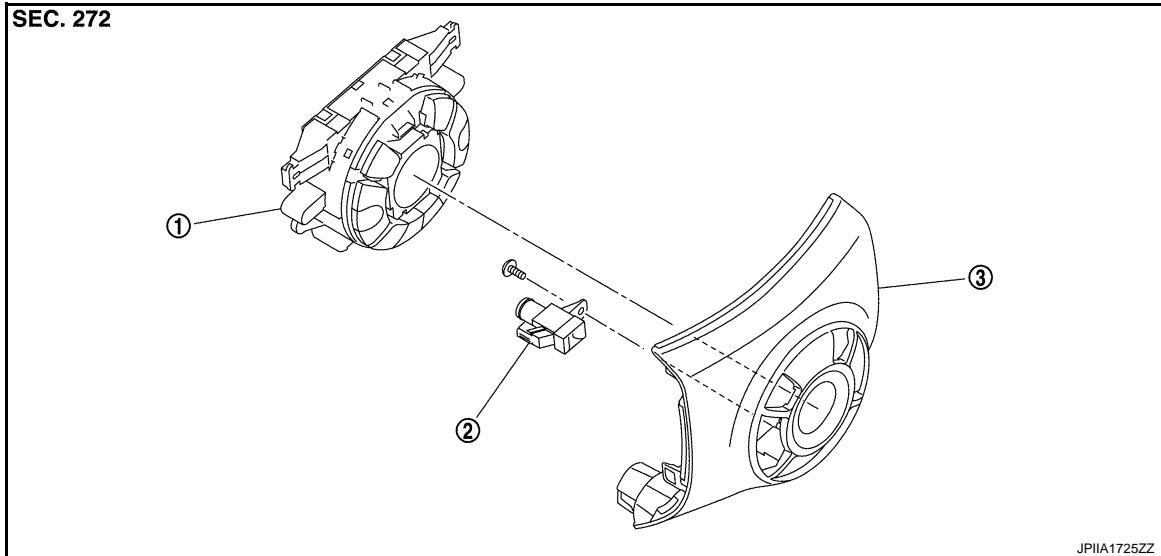

1. A/C control

2. In-vehicle sensor

3. A/C finisher

### Removal and Installation

INFOID:000000005490103

HAC

#### REMOVAL

1. Remove A/C finisher. Refer to [IP-12. "Exploded View"](#).
2. Remove mounting screws (A).

 : Pawl

3. Disengage the pawls, and then remove A/C control (1) from A/C finisher.

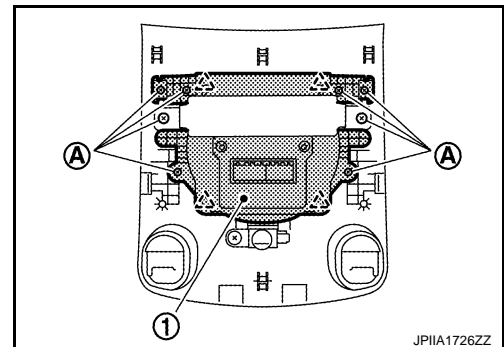

#### INSTALLATION

Installation is basically the reverse order of removal.

# AMBIENT SENSOR

< REMOVAL AND INSTALLATION >

[AUTOMATIC AIR CONDITIONING]

## AMBIENT SENSOR

### Exploded View

INFOID:000000005490104

1. Ambient sensor

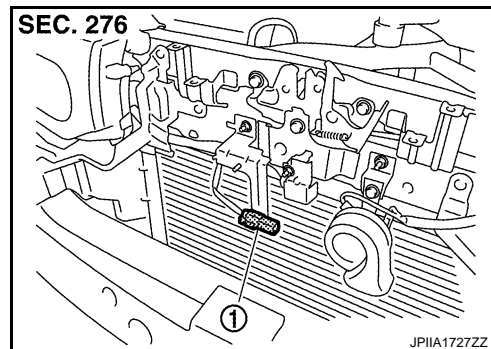

### Removal and Installation

INFOID:000000005490105

#### REMOVAL

1. Remove the bumper fascia. Refer to [EXT-12, "Exploded View"](#).
2. Disengage the pawl, and then remove ambient sensor (2) from bracket (1).

 : Pawl

3. Disconnect ambient sensor connector, and then remove the ambient sensor.

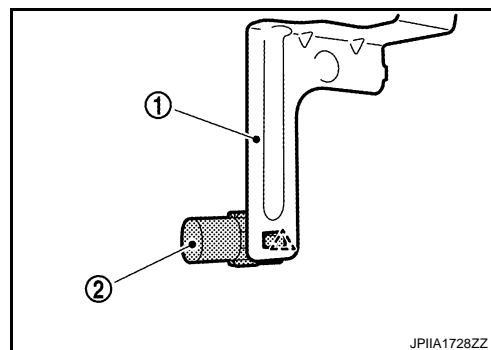

#### INSTALLATION

Installation is basically the reverse order of removal.



# IN-VEHICLE SENSOR

< REMOVAL AND INSTALLATION >

[AUTOMATIC AIR CONDITIONING]

## IN-VEHICLE SENSOR

Exploded View

INFOID:000000005490106

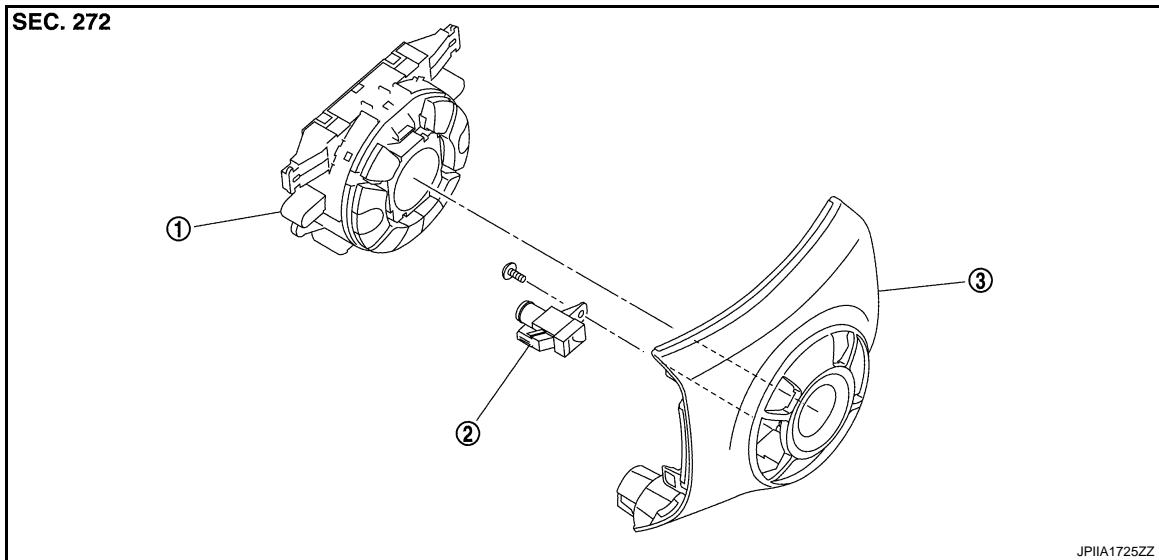

1. A/C control

2. In-vehicle sensor

3. A/C finisher

## Removal and Installation

INFOID:000000005490107

### REMOVAL

1. Remove A/C finisher. Refer to [IP-12, "Exploded View"](#).
2. Remove mounting screw, and then remove in-vehicle sensor from A/C finisher.

### INSTALLATION

Installation is basically the reverse order of removal.

A  
B  
C  
D  
E  
F  
G  
H  
J  
K  
L  
M  
N  
O  
P

HAC

# SUNLOAD SENSOR

< REMOVAL AND INSTALLATION >

[AUTOMATIC AIR CONDITIONING]

## SUNLOAD SENSOR

### Exploded View

INFOID:000000005490108

1. Sunload sensor

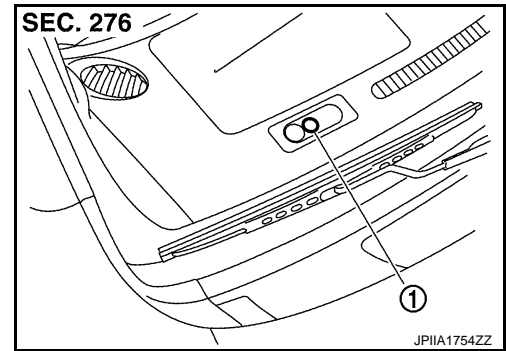

### Removal and Installation

INFOID:000000005490109

#### REMOVAL

1. Insert the appropriate tool into the clearance between sunload sensor and instrument panel assembly to pull out sunload sensor upward.
2. Disconnect sunload sensor connector to remove sunload sensor.

#### INSTALLATION

Installation is basically the reverse order of removal.

# INTAKE SENSOR

< REMOVAL AND INSTALLATION >

[AUTOMATIC AIR CONDITIONING]

## INTAKE SENSOR

### Exploded View

INFOID:000000005490110

Refer to [HA-40, "Exploded View \(Automatic Air Conditioner\)"](#).

### Removal and Installation

INFOID:000000005490111

#### REMOVAL

1. Remove the evaporator assembly. Refer to [HA-40, "Exploded View \(Automatic Air Conditioner\)"](#).
2. Remove the intake sensor from evaporator.

#### INSTALLATION

Installation is basically the reverse order of removal.

#### **CAUTION:**

- Replace O-rings with new ones. Then apply the compressor oil to them when installing.
- Mark the mounting position of intake sensor bracket prior to removal so that the reinstalled sensor can be located in the same position.
- Never rotate the bracket insertion part when removing and installing the intake sensor.
- Check for leakages when recharging refrigerant. Refer to [HA-22, "Leak Test"](#).

A  
B  
C  
D  
E  
F  
G  
H  
J  
K  
L  
M  
N  
O  
P

HAC

# REFRIGERANT PRESSURE SENSOR

< REMOVAL AND INSTALLATION >

[AUTOMATIC AIR CONDITIONING]

## REFRIGERANT PRESSURE SENSOR

Exploded View

INFOID:000000005490112

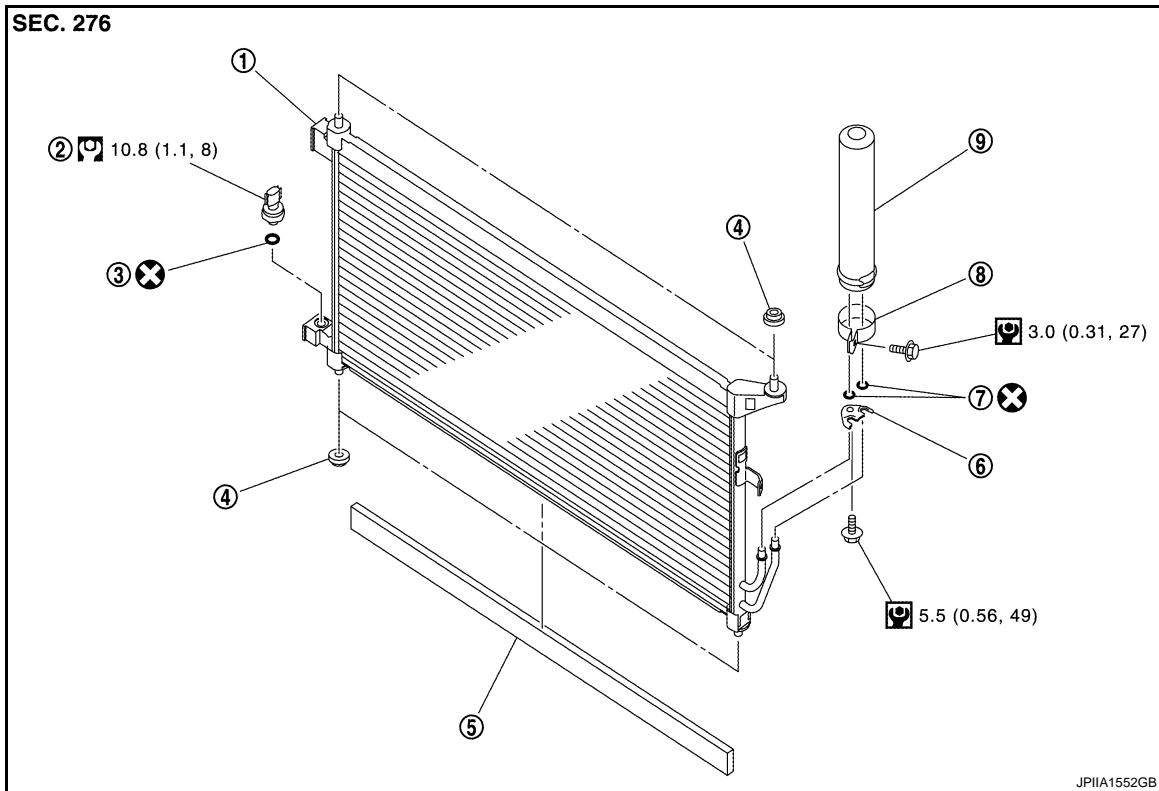

- |              |                                |                |
|--------------|--------------------------------|----------------|
| 1. Condenser | 2. Refrigerant pressure sensor | 3. O-ring      |
| 4. Grommet   | 5. Condenser seal              | 6. Bracket     |
| 7. O-ring    | 8. Liquid tank bracket         | 9. Liquid tank |

Refer to [GI-4. "Components"](#) for symbols in the figure.

## Removal and Installation

INFOID:000000005490113

### CAUTION:

Perform lubricant return operation before each refrigeration system disassembly. However, if a large amount of refrigerant or lubricant is detected, never perform lubricant return operation. Refer to [HA-26. "Perform Lubricant Return Operation"](#).

### REMOVAL

1. Use a refrigerant collecting equipment (for HFC-134a) to discharge the refrigerant. Refer to [HA-24. "Recycle Refrigerant"](#).
2. Clean refrigerant pressure sensor and its surrounding area, and then remove dust and rust from refrigerant pressure sensor.

### CAUTION:

**Be sure to clean carefully.**

3. Disconnect refrigerant pressure sensor connector.

# REFRIGERANT PRESSURE SENSOR

< REMOVAL AND INSTALLATION >

[AUTOMATIC AIR CONDITIONING]

4. Use a adjustable wrench (A) or other tool to hold the refrigerant pressure sensor mounting block, and then remove the refrigerant pressure sensor (2) from the condenser (1).

**CAUTION:**

- Be careful not to damage liquid tank.
- Be careful not to damage core surface of condenser.
- Cap or wrap the joint of the condenser and liquid tank with suitable material such as vinyl tape to avoid the entry of air.

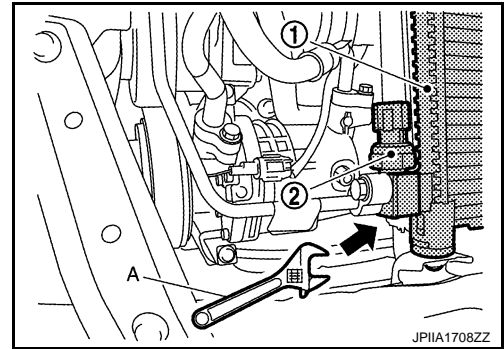

## INSTALLATION

Installation is basically the reverse order of removal.

**CAUTION:**

- Replace O-ring with new one. Then apply compressor oil to them when installing.
- Check for leakages when recharging refrigerant. Refer to [HA-22, "Leak Test"](#).

A  
B  
C  
D  
E  
F  
G  
H  
HAC  
J  
K  
L  
M  
N  
O  
P

# POWER TRANSISTOR

< REMOVAL AND INSTALLATION >

[AUTOMATIC AIR CONDITIONING]

## POWER TRANSISTOR

### Exploded View

INFOID:000000005490114

Refer to [VTL-13, "Exploded View"](#)

### Removal and Installation

INFOID:000000005490115

#### REMOVAL

1. Remove instrument panel assembly. Refer to [IP-12, "Exploded View"](#).
2. Remove cowl top extension. Refer to [EXT-20, "Exploded View"](#).
3. Remove instrument stay.
4. Remove mounting bolts (A), and then move steering member (1) to a position where it does not inhibit work.

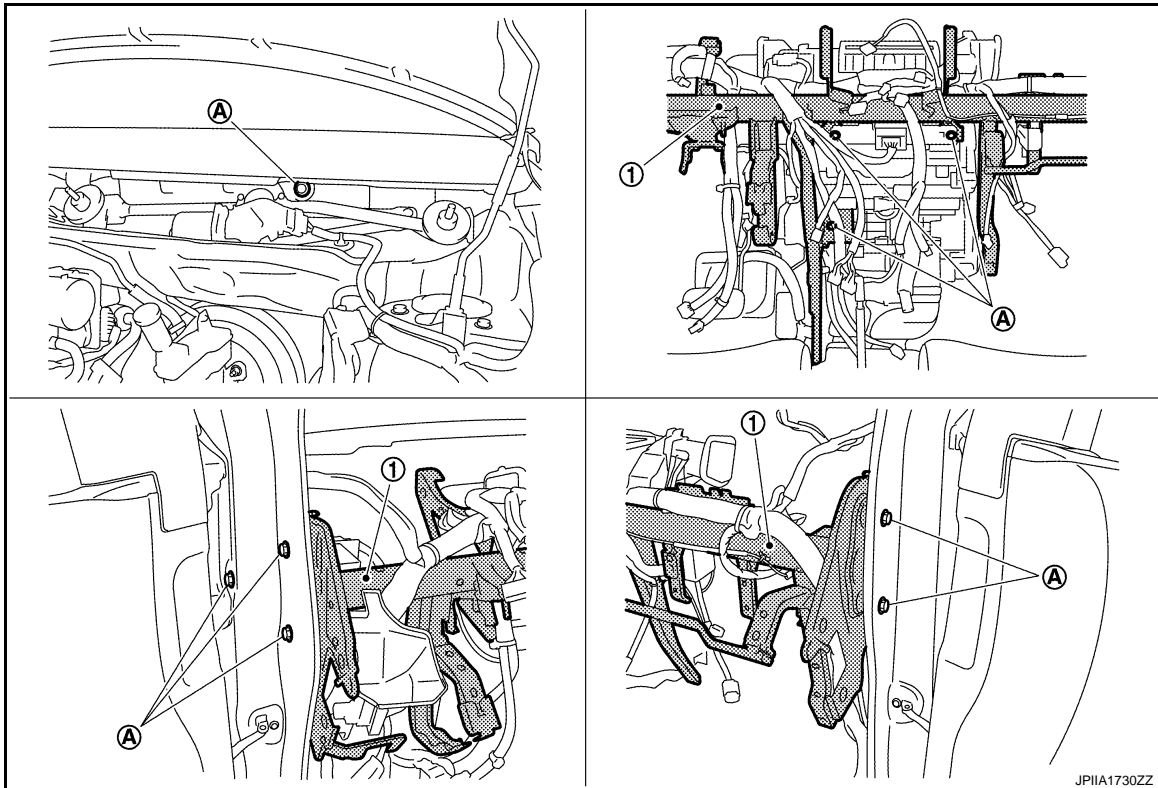

5. Disconnect power transistor connector.
6. Press flange holding hook (A), and then slide heater core to leftward.
7. Remove power transistor (1) from the A/C unit assembly.

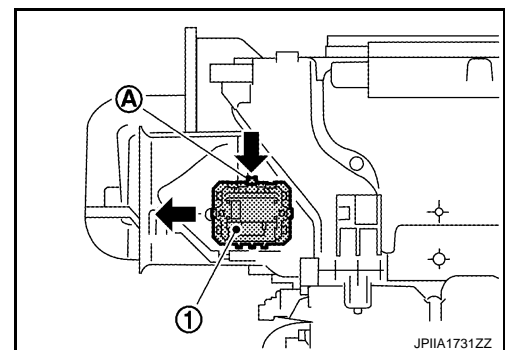

#### INSTALLATION

Installation is basically the reverse order of removal.

# DOOR MOTOR

< REMOVAL AND INSTALLATION >

[AUTOMATIC AIR CONDITIONING]

## DOOR MOTOR

Exploded View

INFOID:000000005490116

LEFT SIDE

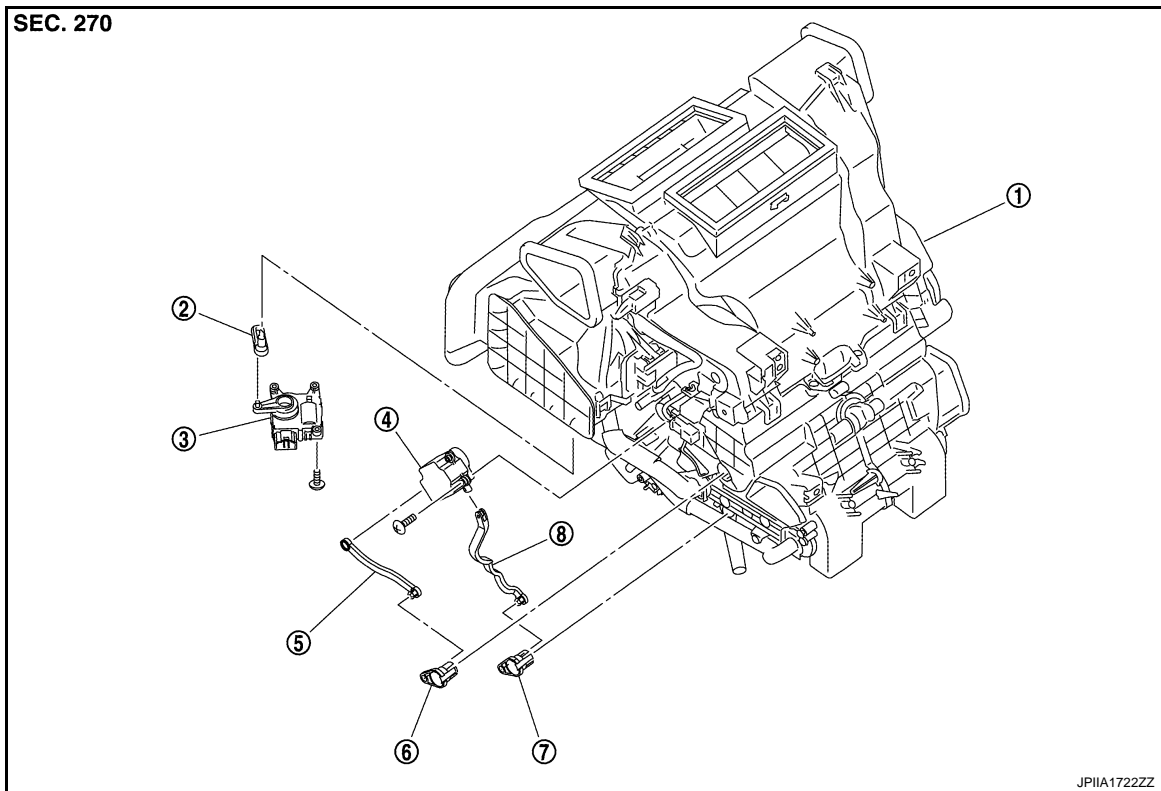

- |                             |                           |                             |
|-----------------------------|---------------------------|-----------------------------|
| 1. A/C unit assembly        | 2. Intake door lever      | 3. Intake door motor        |
| 4. Air mix door motor       | 5. Upper air mix door rod | 6. Upper air mix door lever |
| 7. Lower air mix door lever | 8. Lower air mix door rod |                             |

RIGHT SIDE

A  
B  
C  
D  
E  
F  
G  
H  
HAC  
J  
K  
L  
M  
N  
O  
P

# DOOR MOTOR

< REMOVAL AND INSTALLATION >

[AUTOMATIC AIR CONDITIONING]

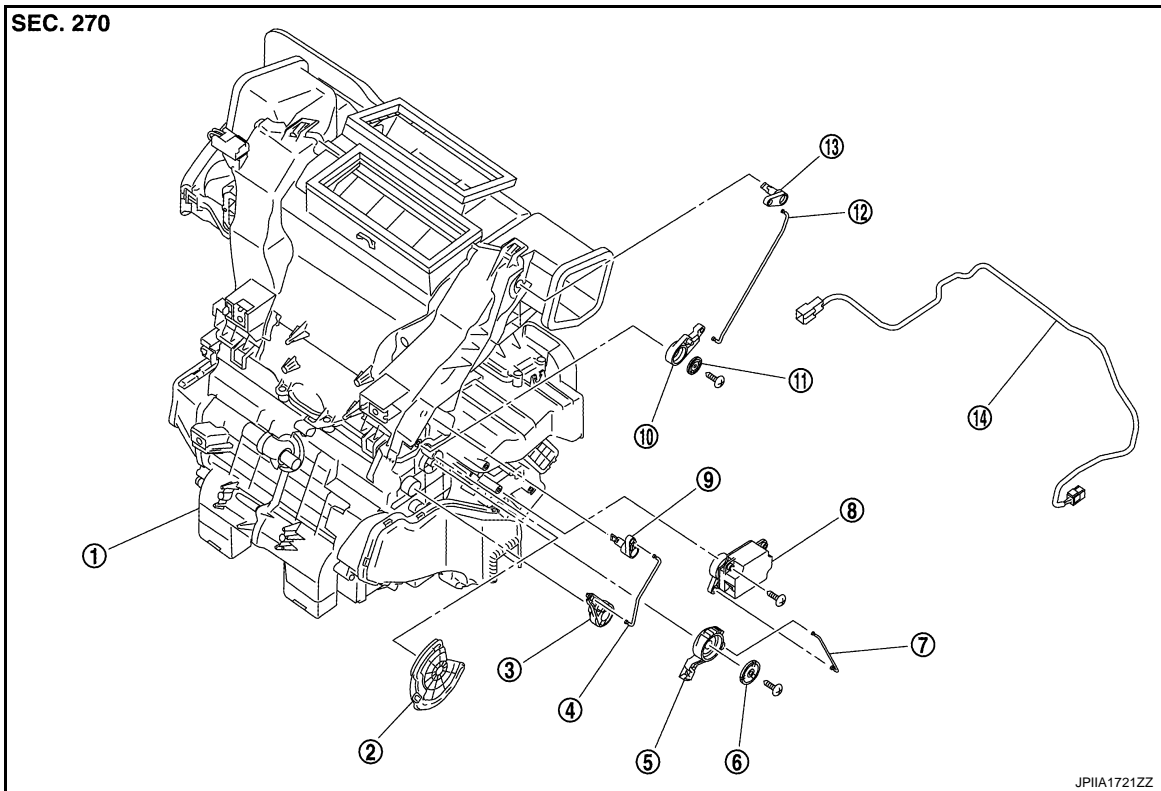

- |  |                                   |  |
|--|-----------------------------------|--|
| 1. A/C unit assembly                           | 2. Main link                      | 3. Sub defroster door link                   |
| 4. Sub defroster door rod                      | 5. Mode link                      | 6. Plate                                     |
| 7. Mode link rod                               | 8. Mode door motor                | 9. Sub defroster door lever                  |
| 10. Center ventilator and defroster door link  | 11. Plate                         | 12. Center ventilator and defroster door rod |
| 13. Center ventilator and defroster door lever | 14. Sub harness (mode door motor) |  |

## INTAKE DOOR MOTOR

### INTAKE DOOR MOTOR : Removal and Installation

INFOID:000000005490117

#### REMOVAL

1. Remove air mix door motor. Refer to [HAC-151, "Exploded View"](#).
2. Remove mounting screws (A), and then remove intake door motor (1).
3. Disconnect intake door motor connector.

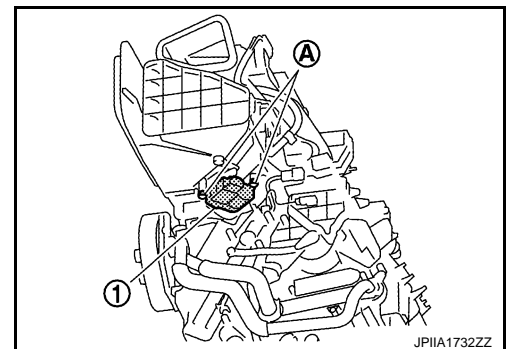

#### INSTALLATION

Installation is basically the reverse order of removal.

## MODE DOOR MOTOR



# DOOR MOTOR

< REMOVAL AND INSTALLATION >

[AUTOMATIC AIR CONDITIONING]

## MODE DOOR MOTOR : Removal and Installation

INFOID:000000005490118

### REMOVAL

1. Remove globe box assembly. Refer to [IP-12, "Exploded View"](#).
2. Remove mounting screws (A), and then remove mode door motor (1).
3. Disconnect mode door motor connector.

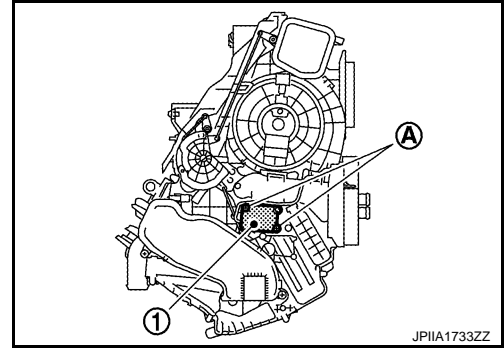

### INSTALLATION

Installation is basically the reverse order of removal.

## AIR MIX DOOR MOTOR

## AIR MIX DOOR MOTOR : Removal and Installation

INFOID:000000005490119

### REMOVAL

1. Remove foot duct LH. Refer to [VTL-7, "Exploded View"](#).
2. Remove mounting screws (A), and then remove air mix door motor (1).
3. Disconnect air mix door motor connector.

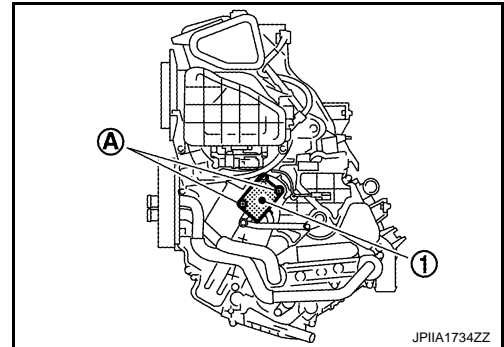

### INSTALLATION

Installation is basically the reverse order of removal.

A  
B  
C  
D  
E  
F  
G  
H  
HAC  
J  
K  
L  
M  
N  
O  
P

# DIAGNOSIS AND REPAIR WORKFLOW

< BASIC INSPECTION >

[MANUAL AIR CONDITIONING]

## BASIC INSPECTION

### DIAGNOSIS AND REPAIR WORKFLOW

Work Flow

INFOID:000000005490120

#### OVERALL SEQUENCE

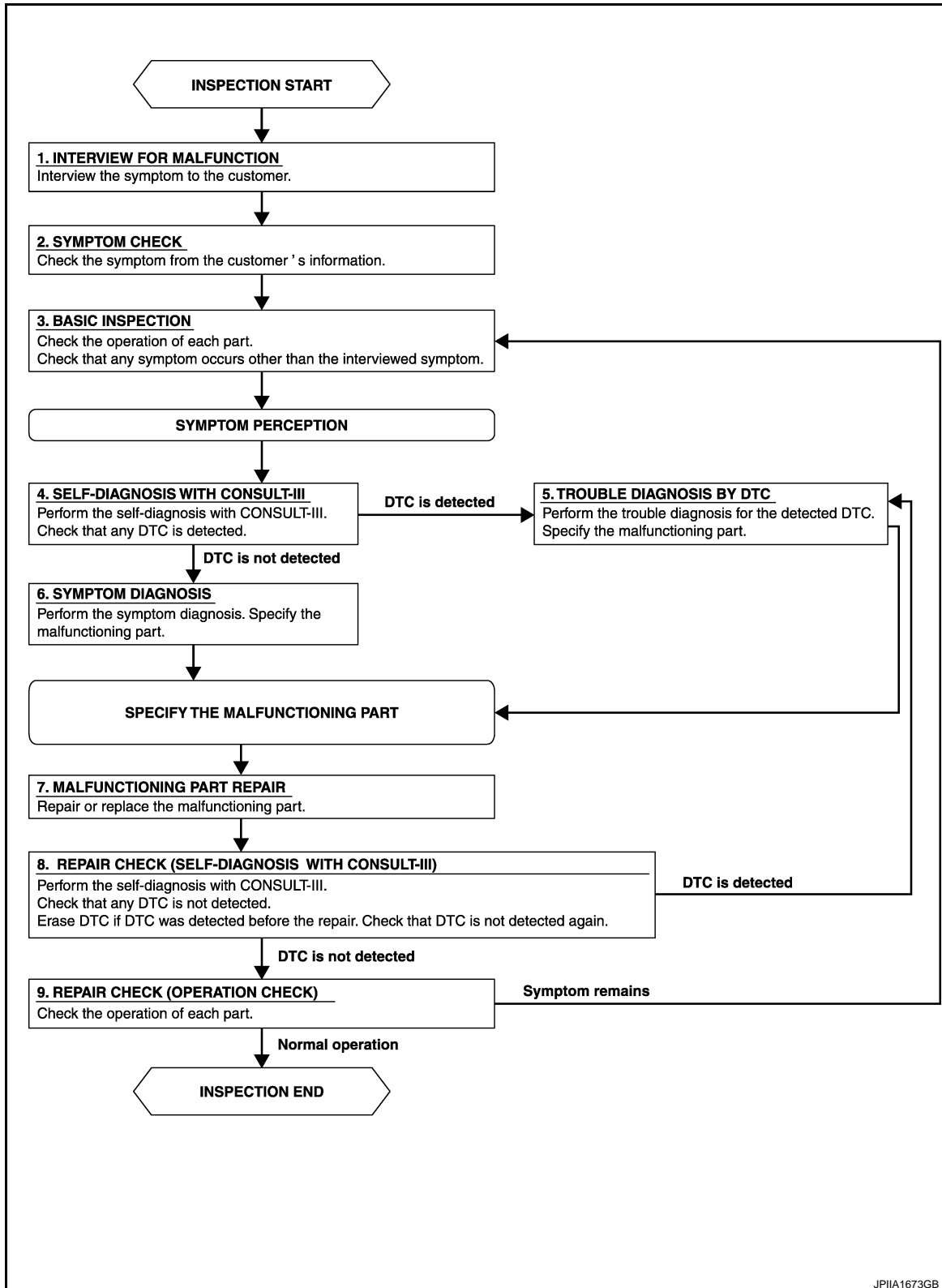

JPIIA1673GB

#### DETAILED FLOW

# DIAGNOSIS AND REPAIR WORKFLOW

< BASIC INSPECTION >

[MANUAL AIR CONDITIONING]

---

## 1. INTERVIEW FOR MALFUNCTION

---

Interview the symptom to the customer.

>> GO TO 2.

---

## 2. SYMPTOM CHECK

---

Check the symptom from the customer's information.

>> GO TO 3.

---

## 3. BASIC INSPECTION

---

Check the operation of each part. Check that any symptom occurs other than the interviewed symptom.

>> GO TO 4.

---

## 4. SELF-DIAGNOSIS WITH CONSULT-III

---

Perform the self-diagnosis with CONSULT-III. Check that any DTC is detected.

Is any DTC detected?

YES >> GO TO 5.

NO >> GO TO 6.

---

## 5. TROUBLE DIAGNOSIS BY DTC

---

Perform the trouble diagnosis for the detected DTC. Specify the malfunctioning part.

>> GO TO 6.

---

## 6. SYMPTOM DIAGNOSIS

---

Perform the symptom diagnosis. Specify the malfunctioning part.

>> GO TO 7.

---

## 7. MALFUNCTION PART REPAIR

---

Repair or replace the malfunctioning part.

>> GO TO 8.

---

## 8. REPAIR CHECK (SELF-DIAGNOSIS WITH CONSULT-III)

---

Perform the self-diagnoses with CONSULT-III. Check that any DTC is not detected. Erase DTC if DTC is detected before the repair. Check that DTC is not detected again.

Is any or malfunction result or DTC detected?

YES >> If DTC is detected, GO TO 5.

NO >> GO TO 9.

---

## 9. REPAIR CHECK (OPERATION CHECK)

---

Check the operation of each part.

Does it operate normally?

YES >> INSPECTION END

NO >> GO TO 3.

A  
B  
C  
D  
E  
F  
G  
H  
HAC  
J  
K  
L  
M  
N  
O  
P

## INSPECTION

## Description &amp; Inspection

INFOID:000000005490121

## DESCRIPTION

The purpose of the operational check is to check that the individual system operates normally.

**Check condition : Engine running at normal operating temperature.**

**1.CHECK BLOWER MOTOR**

1. Start the engine.
2. Operate the fan control dial. Check that the fan speed changes. Check the operation for all fan speeds.
3. Leave blower on maximum speed.

Is the inspection result normal?

YES >> GO TO 2.

NO >> Blower motor system malfunction. Refer to [HAC-175, "Diagnosis Procedure"](#).

**2.CHECK DISCHARGE AIR**

1. Operate MODE dial to each position.
2. Check that the air outlets change according to each indicated air outlet by placing a hand in front of the outlets. Refer to [VTL-2, "System Description"](#).

Is the inspection result normal?

YES >> GO TO 3.

NO >> Replace the mode door cable.

**3.CHECK INTAKE AIR**

1. Operate MODE control dial to VENT position.
2. Press intake switch to set the air outlet to recirculation.
3. The intake switch indicator turns ON.
4. Listen to intake sound and confirm air inlets change.
5. Press intake switch again to set the air outlet to fresh air intake.
6. The intake switch indicator turns OFF.
7. Listen to intake sound and confirm air inlets change.

Is the inspection result normal?

YES >> GO TO 4.

NO >> Intake door system malfunction. Refer to [HAC-170, "Diagnosis Procedure"](#).

**4.CHECK A/C SWITCH**

1. Press the A/C switch.
2. Check that the indicator of the A/C switch turns ON. Check visually and by sound that the compressor operates.
3. Press the A/C switch again.
4. Check that the indicator of the A/C switch turns OFF. Check that the compressor stops.

Is the inspection result normal?

YES >> GO TO 5.

NO >> Magnet clutch system malfunction. Refer to [HAC-179, "Diagnosis Procedure"](#).

**5.CHECK TEMPERATURE DECREASE**

1. Operate the compressor.
2. Turn the temperature control dial to full cold position.
3. Check that the cool air blows from the outlets.

Is the inspection result normal?

YES >> GO TO 6.

NO >> Insufficient cooling. Refer to [HAC-217, "Diagnosis Procedure"](#).

**6.CHECK TEMPERATURE INCREASE**

1. Turn temperature control dial to full hot position after warming up the engine.

# INSPECTION

[MANUAL AIR CONDITIONING]

< BASIC INSPECTION >

2. Check that warm air blows from outlets.

Is the inspection result normal?

YES >> INSPECTION END

NO >> Insufficient heating. Refer to [HAC-218, "Diagnosis Procedure"](#).

A

B

C

D

E

F

G

H

HAC

J

K

L

M

N

O

P

# COMPRESSOR CONTROL FUNCTION

< SYSTEM DESCRIPTION >

[MANUAL AIR CONDITIONING]

## SYSTEM DESCRIPTION

### COMPRESSOR CONTROL FUNCTION

#### Description

INFOID:000000005490122

#### PRINCIPLE OF OPERATION

Compressor is not activated.

#### Functional Circuit Diagram

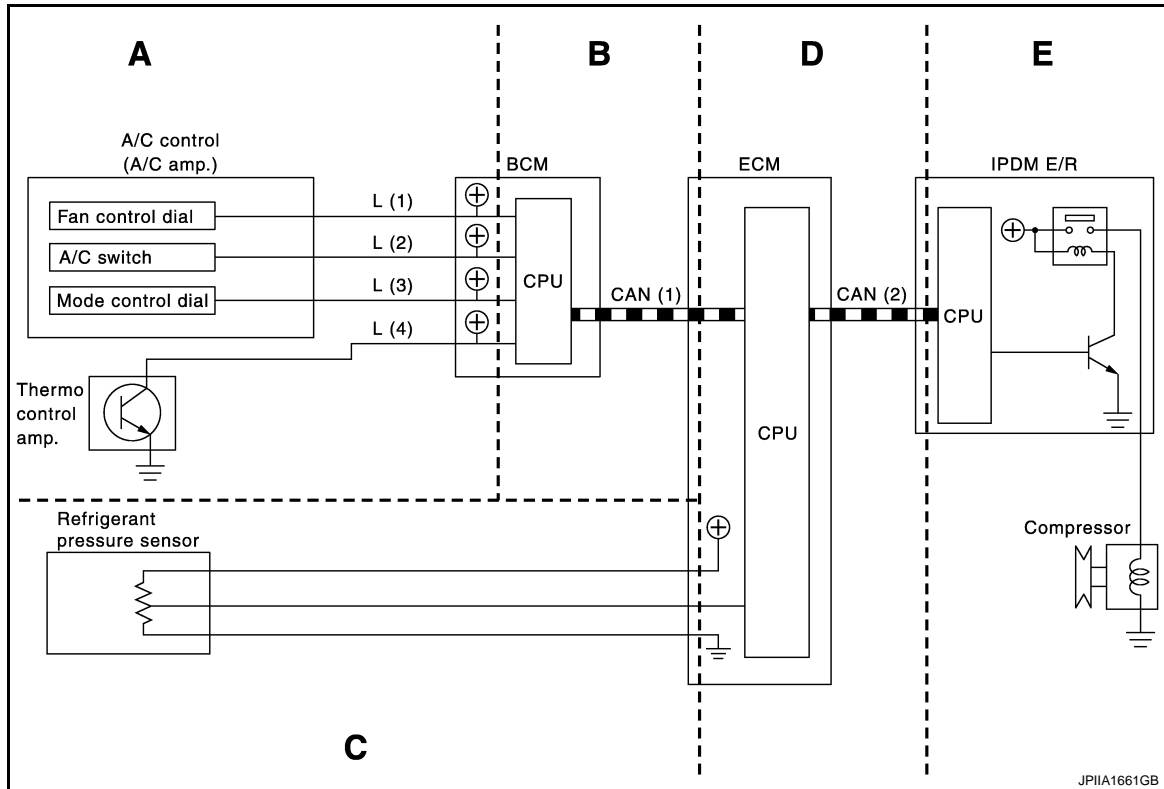

- |                                       |   |
|---------------------------------------|---|
| L (1) : Fan ON signal                 | CAN (1) : A/C ON signal                 |
| L (2) : A/C switch signal             | : Blower fan ON signal                  |
| L (3) : Defroster position switch 2   | CAN (2) : A/C compressor request signal |
| L (4) : Thermo control amp. ON signal | : A/C compressor feedback signal        |

#### Functional Initial Inspection Chart

×: Applicable

Control unit	Diagnosis item	Location				
		A	B	C	D	E
BCM	Self-diagnosis ④ "BCM-AIR COND"	—	×	—	—	—
	Data monitor	×	—	—	—	—
ECM	Self-diagnosis (CAN communication line) ④ "ENGINE"	—	—	—	×	—
	Data monitor	—	×	×	—	—
IPDM E/R	Self-diagnosis (CAN communication line) ④ "IPDM E/R"	—	—	—	—	×
	Data monitor	—	—	—	×	—
	Auto active test	—	—	—	—	×

# COMPRESSOR CONTROL FUNCTION

< SYSTEM DESCRIPTION >

[MANUAL AIR CONDITIONING]

## Component Part Location

INFOID:000000005490123

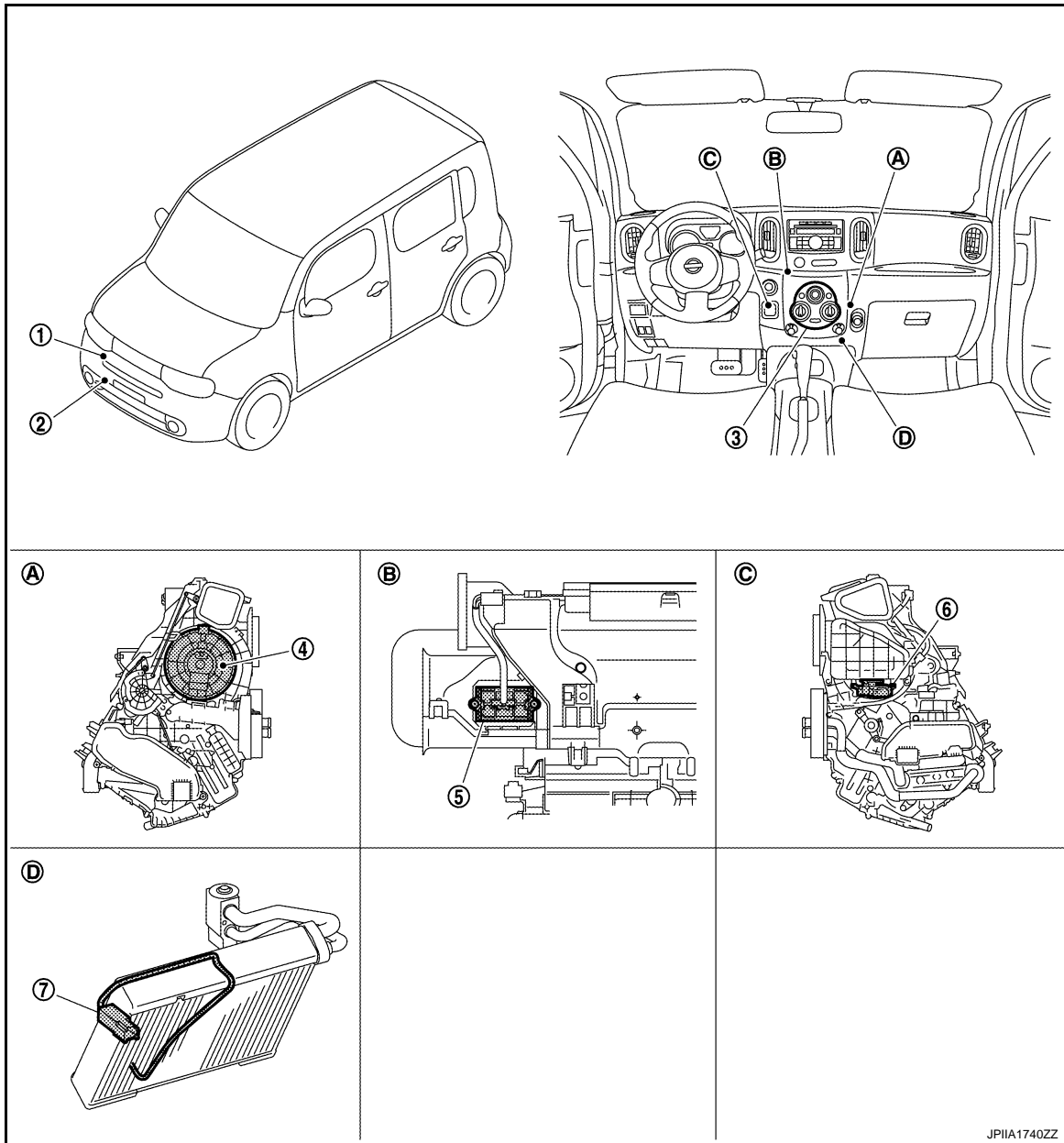

- |   |   |  |
|---|---|--|
| 1. Magnet clutch                                  | 2. Refrigerant pressure sensor              | 3. A/C control                                   |
| 4. Blower motor                                   | 5. Blower fan resistor                      | 6. Intake door motor                             |
| 7. Thermo control amp.                            |   |  |
| A. Located in the right side of A/C unit assembly | B. Located in the back of A/C unit assembly | C. Located in the left side of A/C unit assembly |
| D. Located on evaporator                          |   |  |

## Component Description

INFOID:000000005490124

Component	Reference/Function
Magnet clutch	<a href="#">HAC-179. "Description"</a>
Refrigerant pressure sensor	<a href="#">EC-415. "Description"</a>
A/C control	Controls the air conditioner function.

# COMPRESSOR CONTROL FUNCTION

< SYSTEM DESCRIPTION >

[MANUAL AIR CONDITIONING]

Component	Reference/Function
Blower motor	<a href="#">HAC-175. "Description"</a>
Blower fan resistor	<a href="#">HAC-175. "Description"</a>
Intake door motor	<a href="#">HAC-170. "Description"</a>
Thermo control amp.	<a href="#">HAC-172. "Description"</a>



# MANUAL AIR CONDITIONING SYSTEM

< SYSTEM DESCRIPTION >

[MANUAL AIR CONDITIONING]

## MANUAL AIR CONDITIONING SYSTEM

### System Diagram

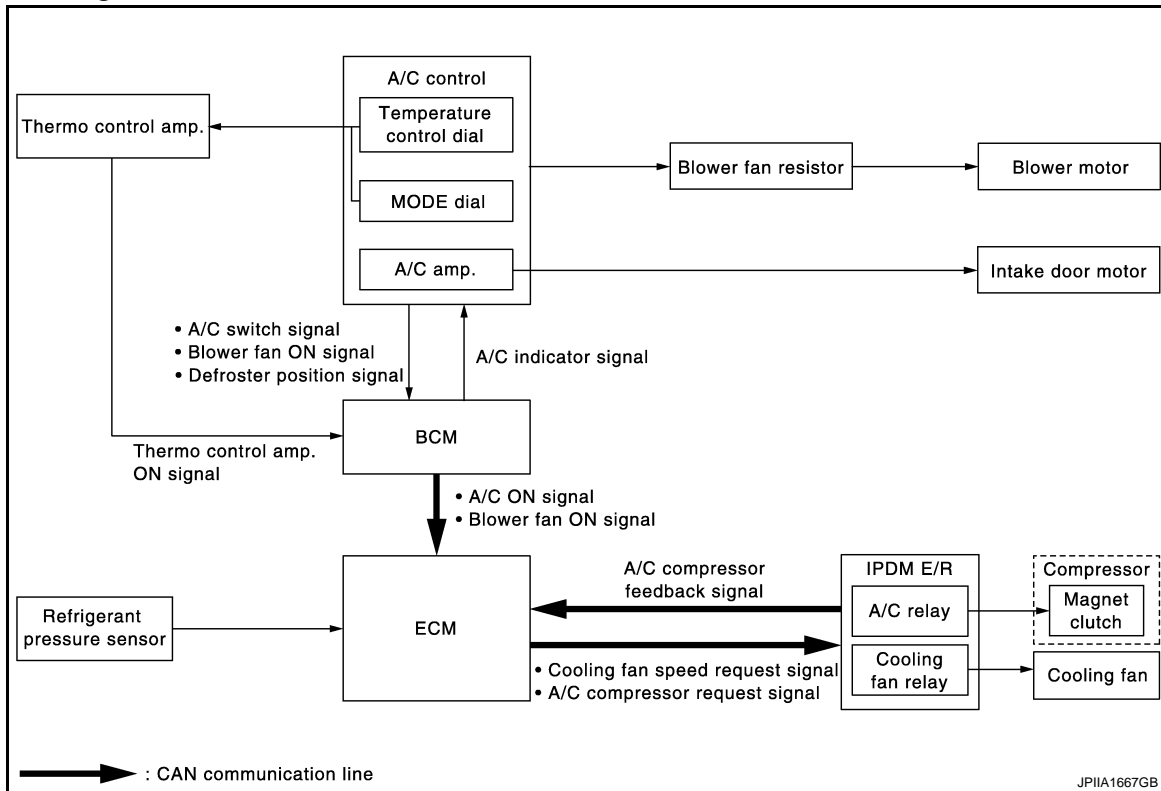

### System Description

INFOID:000000005490126

#### SYSTEM DESCRIPTION

- Manual air conditioner system is controlled by each function of BCM, ECM or IPDM E/R.

##### Control by BCM

- Compressor control

##### Control by ECM

- Compressor control
- Cooling fan control. Refer to [EC-61, "System Description"](#).
- Air conditioner cut control. Refer to [EC-45, "System Description"](#).

##### Control by IPDM E/R

- Relay control. Refer to [PCS-35, "System Description"](#).
- Cooling fan control. Refer to [PCS-35, "System Description"](#).

- Fan speed of blower fan motor is changed by the combination of fan switch operation and blower fan resistor control.

#### OPERATION

##### A/C Control

# MANUAL AIR CONDITIONING SYSTEM

< SYSTEM DESCRIPTION >

[MANUAL AIR CONDITIONING]

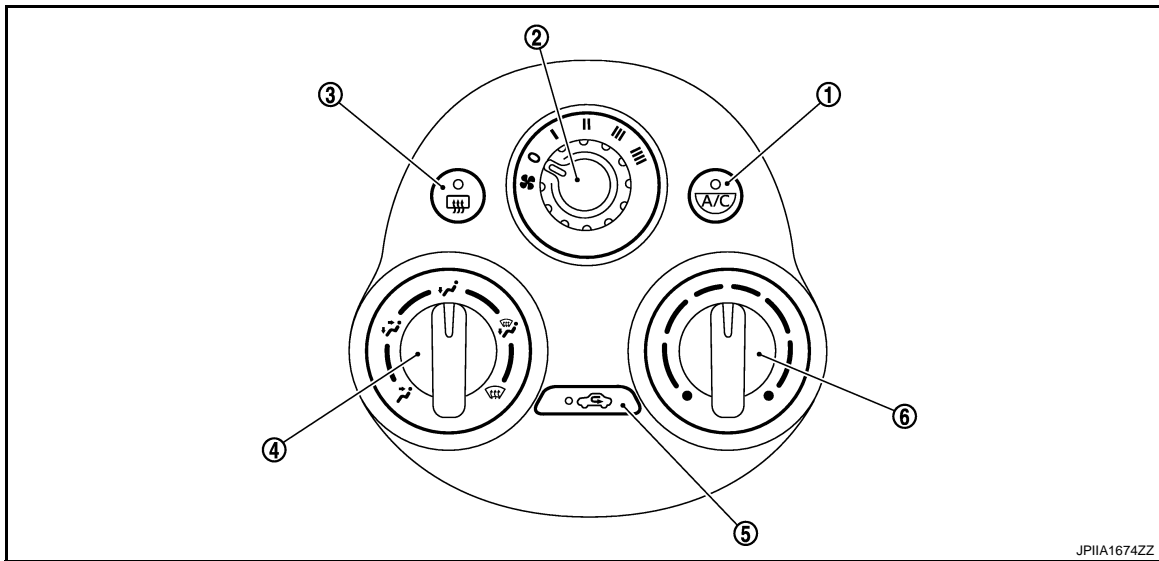

- |               |                     |                                |
|---------------|---------------------|--------------------------------|
| 1. A/C switch | 2. Fan control dial | 3. Rear window defogger switch |
| 4. MODE dial  | 5. Intake switch    | 6. Temperature control dial    |

A/C switch	The compressor control (switch indicator) is turned ON ⇔ OFF each time by pressing this switch while the blower motor is activated. <b>NOTE:</b> when mode position is D/F or DEF, A/C switch is turned ON forcibly.
Fan control dial	Fan speed can be adjusted within a range from 1st to 4th.
Rear window defogger switch	<ul style="list-style-type: none"> <li>• Rear window defogger (switch indicator) is turned ON ⇔ OFF each time by pressing this switch.</li> <li>• Rear window defogger system details, Refer to <a href="#">DEF-4, "System Description"</a>.</li> </ul>
MODE dial	<ul style="list-style-type: none"> <li>• Mode position is selected to an optimal position by operating this dial.</li> <li>• When DEF or D/F is selected while blower motor is activated, the air conditioner will automatically turn on and the air inlet becomes fresh air intake.</li> </ul>
Intake switch	The air inlet changed ON ⇔ OFF each time by pressing this switch. <ul style="list-style-type: none"> <li>• Indicator ON: Recirculation</li> <li>• Indicator OFF: Fresh air intake</li> </ul> <b>NOTE:</b> when mode position is D/F or DEF, air inlet is set to FRE forcibly.
Temperature control dial	The setting temperature can be selected to an optimum temperature by operating this dial.

## COMPRESSOR CONTROL

### Description

- BCM transmits the A/C ON signal and blower fan ON signal to ECM via CAN communication line only when the compressor operational condition is satisfied, and A/C indicator is turned ON.

**NOTE:**

Compressor operational condition

- Thermo control amp. signal ON
- Blower fan signal ON
- A/C switch signal ON
- ECM judges the conditions of each sensor (Refrigerant pressure sensor signal, accelerator position signal, etc.), and transmits the A/C compressor request signal to IPDM E/R via CAN communication line.
- By receiving the A/C compressor request signal from ECM, IPDM E/R turns the A/C relay to ON, and activates the compressor.

### Compressor Protection Control at Pressure Malfunction

The high-pressure side value that is detected by refrigerant pressure sensor is as per the following state, ECM requests IPDM E/R to turn A/C relay OFF and stop the compressor.

- 3.12 MPa (31.8 kg/cm<sup>2</sup>, 452 psi) or more (When the engine speed is less than 1,500 rpm)

# MANUAL AIR CONDITIONING SYSTEM

[MANUAL AIR CONDITIONING]

## < SYSTEM DESCRIPTION >

- 2.74 MPa (27.9 kg/cm<sup>2</sup>, 397 psi) or more (When the engine speed is 1,500 rpm or more)
- 0.14 MPa (1.4 kg/cm<sup>2</sup>, 20 psi) or less

### Low Temperature Protection Control

- When the thermo control amp. detects that evaporator surface temperature is 2°C (36°F) or less, thermo control amp. signal becomes OFF, and stops the compressor.
- When the air temperature returns to 3.5°C (38°F) or more, the compressor is activated.

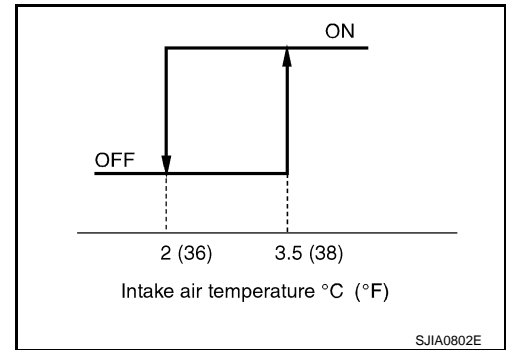

### Operating Rate Control

- Thermo control amp. detects the positions of air temperature control dial and MODE dial.
- Thermo control amp. corrects the stopping temperature of A/C compressor depending on the condition of A/C operation, and prevents too much heating by turning thermo control amp. ON ⇔ OFF.

### Air conditioner Cut Control

When the engine condition is high load, ECM makes the A/C relay to OFF, and stops the compressor. Refer to [EC-45, "System Description"](#).

## SWITCHES AND THEIR CONTROL FUNCTIONS

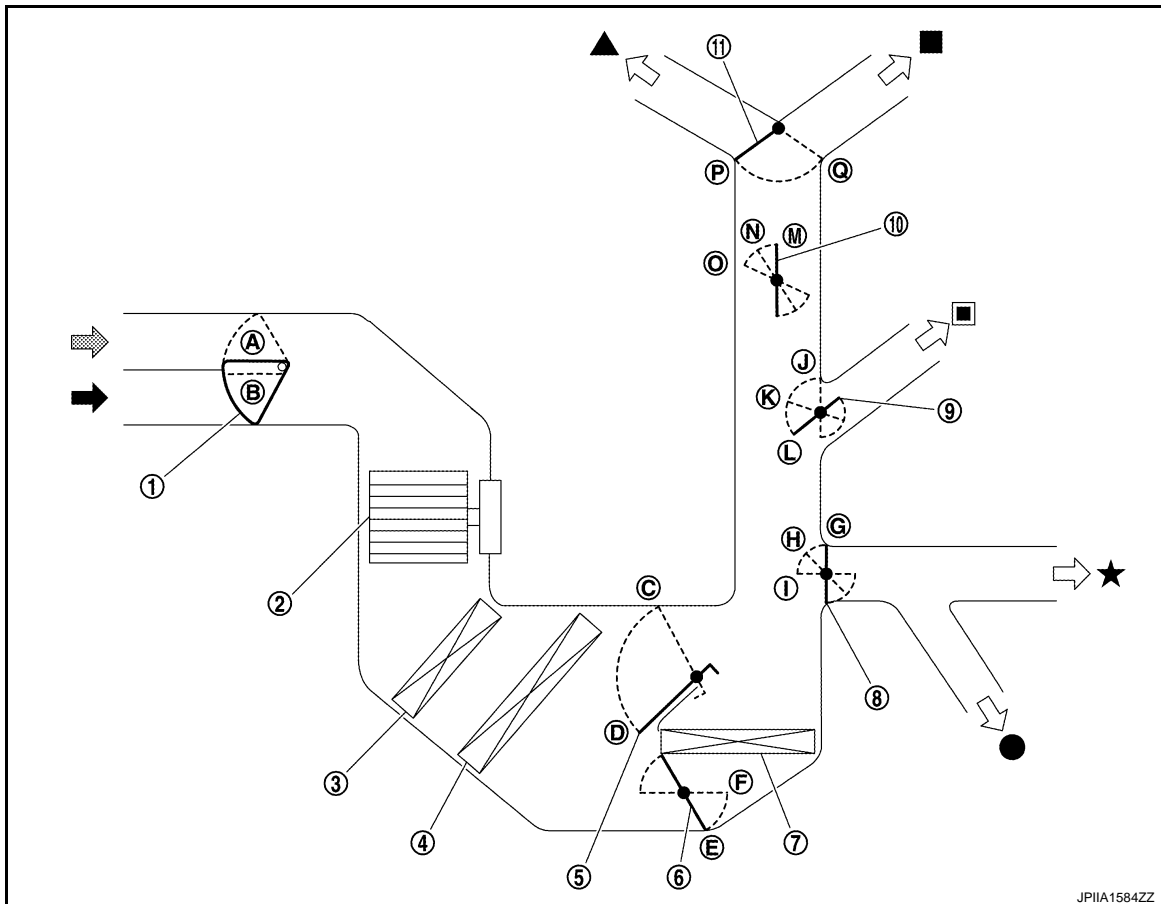







- |                        |  |                         |
|------------------------|--|-------------------------|
| 1. Intake door         | 2. Blower motor                          | 3. In-cabin microfilter |
| 4. Evaporator          | 5. Upper air mix door                    | 6. Lower air mix door   |
| 7. Heater core         | 8. Foot door                             | 9. Side ventilator door |
| 10. Sub defroster door | 11. Center ventilator and defroster door |                         |









# MANUAL AIR CONDITIONING SYSTEM

< SYSTEM DESCRIPTION >

[MANUAL AIR CONDITIONING]





- |   |   |   |
|---|---|---|
|  Fresh air intake  |  Recirculation air |  Defroster |
|  Center ventilator |  Side ventilator   |  Foot      |
|  Rear foot*        |   |   |

\*With rear foot duct





Switch/Dial position		Door position						
		Center ventilator and defroster door	Sub defroster door	Side ventilator door	Foot door	Intake door	Upper air mix door	Lower air mix door
MODE dial		P	M	L	G	—	—	—
				K	H			
		Q	O	J	I			
			N		G			
			M					
Intake switch	 	—	—	—	—	A		
	 					B		
Temperature control dial	Full cold	—	—	—	—	—	D	E
	Full hot						C	F

## AIR DISTRIBUTION

Without Rear Foot Duct

Discharge air flow			
Mode position indication	Air outlet/distribution		
	Ventilator	Foot	Defroster
	100%	—	—
	63%	37%	—
	16%	64%	20%
	14%	55%	31%
	18%	—	82%

With Rear Foot Duct

Discharge air flow				
Mode position indication	Air outlet/distribution			
	Ventilator	Front foot	Rear foot	Defroster
	100%	—	—	—
	57%	29%	14%	—
	19%	44%	19%	18%
	17%	40%	17%	26%
	18%	—	—	82%

# MANUAL AIR CONDITIONING SYSTEM

< SYSTEM DESCRIPTION >

[MANUAL AIR CONDITIONING]

## Component Part Location

INFOID:000000005490127

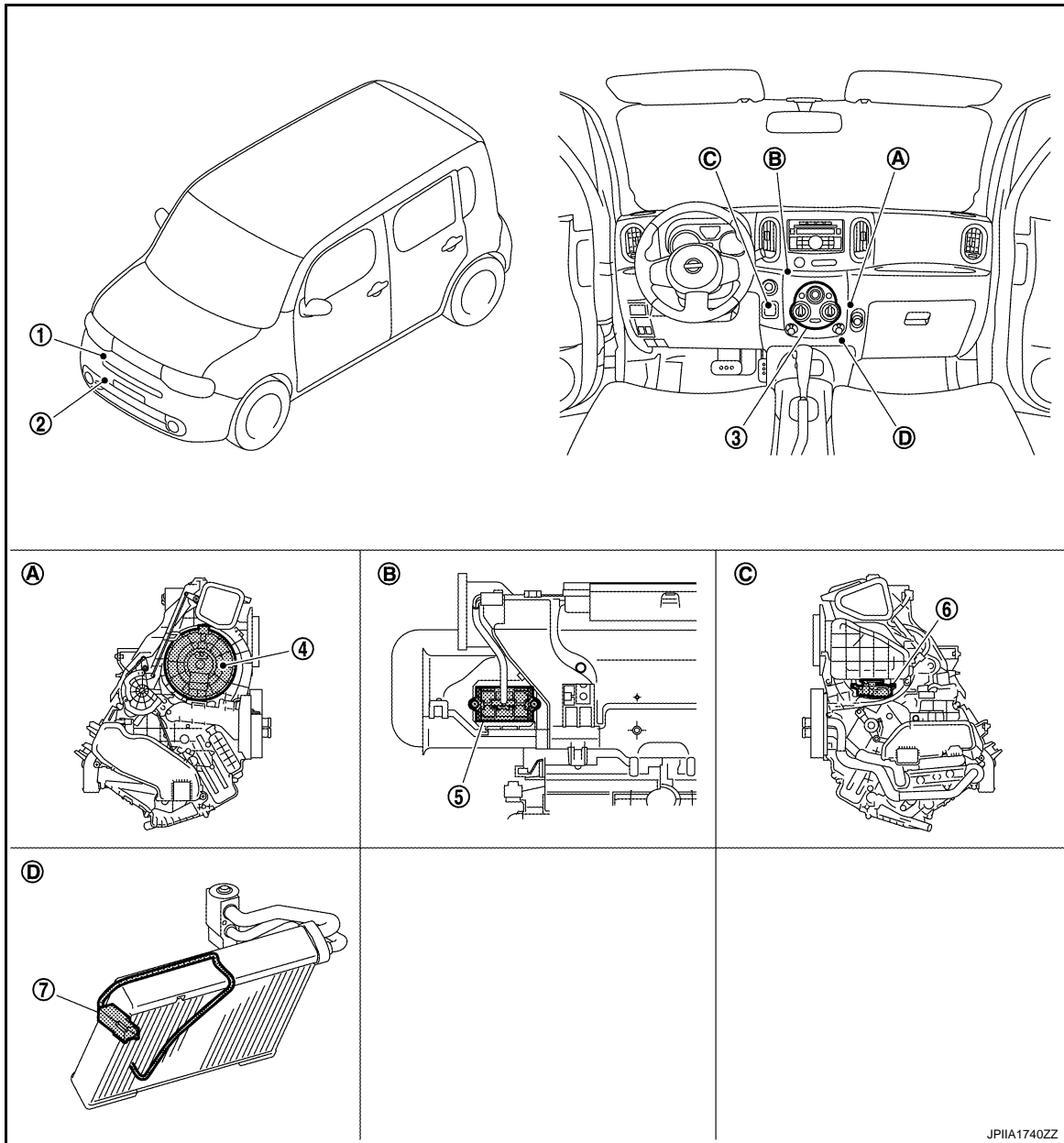

- |   |   |  |
|---|---|--|
| 1. Magnet clutch                                  | 2. Refrigerant pressure sensor              | 3. A/C control                                   |
| 4. Blower motor                                   | 5. Blower fan resistor                      | 6. Intake door motor                             |
| 7. Thermo control amp.                            |   |  |
| A. Located in the right side of A/C unit assembly | B. Located in the back of A/C unit assembly | C. Located in the left side of A/C unit assembly |
| D. Located on evaporator                          |   |  |

## Component Description

INFOID:000000005490128

Component	Reference/Function
Magnet clutch	<a href="#">HAC-179. "Description"</a>
Refrigerant pressure sensor	<a href="#">EC-415. "Description"</a>
A/C control	Controls the air conditioner function.

# MANUAL AIR CONDITIONING SYSTEM

< SYSTEM DESCRIPTION >

[MANUAL AIR CONDITIONING]

Component	Reference/Function
Blower motor	<a href="#">HAC-175. "Description"</a>
Blower fan resistor	<a href="#">HAC-175. "Description"</a>
Intake door motor	<a href="#">HAC-170. "Description"</a>
Thermo control amp.	<a href="#">HAC-172. "Description"</a>

# DIAGNOSIS SYSTEM (BCM)

< SYSTEM DESCRIPTION >

[MANUAL AIR CONDITIONING]

## DIAGNOSIS SYSTEM (BCM)

### COMMON ITEM

### COMMON ITEM : CONSULT-III Function (BCM - COMMON ITEM)

INFOID:000000005845388

### APPLICATION ITEM

CONSULT-III performs the following functions via CAN communication with BCM.

Diagnosis mode	Function Description
Work Support	Changes the setting for each system function.
Self Diagnostic Result	Displays the diagnosis results judged by BCM.
CAN Diag Support Monitor	Monitors the reception status of CAN communication viewed from BCM. Refer to CONSULT-III operation manual.
Data Monitor	The BCM input/output signals are displayed.
Active Test	The signals used to activate each device are forcibly supplied from BCM.
Ecu Identification	The BCM part number is displayed.
Configuration	<ul style="list-style-type: none"> <li>Read and save the vehicle specification.</li> <li>Write the vehicle specification when replacing BCM.</li> </ul>

### SYSTEM APPLICATION

BCM can perform the following functions for each system.

#### NOTE:

It can perform the diagnosis modes except the following for all sub system selection items.

x: Applicable item

System	Sub system selection item	Diagnosis mode		
		Work Support	Data Monitor	Active Test
Door lock	DOOR LOCK	x	x	x
Rear window defogger	REAR DEFOGGER		x	x
Warning chime	BUZZER		x	x
Interior room lamp control	INT LAMP	x	x	x
Remote keyless entry system	MULTI REMOTE ENT	x	x	x
Exterior lamp	HEAD LAMP	x	x	x
Wiper and washer	WIPER	x	x	x
Turn signal and hazard warning lamps	FLASHER		x	x
<ul style="list-style-type: none"> <li>Automatic air conditioner</li> <li>Manual air conditioner</li> </ul>	AIR CONDITONER		x	x
Combination switch	COMB SW		x	
Body control system	BCM	x		
NVIS - NATS	IMMU	x	x	x
Interior room lamp battery saver	BATTERY SAVER	x	x	x
Back door	TRUNK		x	
Vehicle security system	THEFT ALM	x	x	x
RAP system	RETAINED PWR		x	x
Signal buffer system	SIGNAL BUFFER		x	x
TPMS	TPMS (AIR PRESSURE MONITOR)	x	x	x
Panic alarm system	PANIC ALARM			x

### AIR CONDITIONER

# DIAGNOSIS SYSTEM (BCM)

< SYSTEM DESCRIPTION >

[MANUAL AIR CONDITIONING]

## AIR CONDITIONER : CONSULT-III Function

INFOID:000000005490130

### DATA MONITOR

Display Item List

Monitor Item [Unit]	Contents
IGN SW [On/Off]	Displays ignition switch position status as judged from ignition switch signal.
FAN ON SIG [On/Off]	Displays the blower fan status as judged from blower fan motor switch signal.
AIR COND SW [On/Off]	Displays [COMP (On)/COMP (Off)] status as judged from air conditioner switch signal.
THERMO AMP [On/Off]	Displays the thermo control amp. status as judged from thermo control amp. signal.
FR DEF SW [On/Off]	Displays the DEF status as judged from defroster position switch signal.



## DTC/CIRCUIT DIAGNOSIS

### POWER SUPPLY AND GROUND CIRCUIT

#### BCM

#### BCM : Diagnosis Procedure

INFOID:000000005490131

### 1. CHECK FUSES AND FUSIBLE LINK

Check that the following fuses and fusible link are not fusing.

Signal name	Fuses and fusible link No.
Battery power supply	10
	J
ACC power supply	20
Ignition power supply	1

#### Is the fuse fusing?

YES >> Replace the blown fuse or fusible link after repairing the affected circuit if a fuse or fusible link is blown.

NO >> GO TO 2.

### 2. CHECK POWER SUPPLY CIRCUIT

- Turn ignition switch OFF.
- Disconnect BCM connectors.
- Check voltage between BCM harness connector and ground.

Terminals		(-)	Ignition switch position		
(+)			OFF	ACC	ON
Connector	Terminal				
M109	70	Ground	Battery voltage	Battery voltage	Battery voltage
	57				
M107	11		Approx. 0 V	Battery voltage	Battery voltage
	38		Approx. 0 V	Approx. 0 V	Battery voltage

#### Is the measurement value normal?

YES >> GO TO 3.

NO >> Repair harness or connector.

### 3. CHECK GROUND CIRCUIT

Check continuity between BCM harness connector and ground.

BCM		Ground	Continuity
Connector	Terminal		
M109	67		Existed

#### Does continuity exist?

YES >> INSPECTION END

NO >> Repair harness or connector.

# INTAKE DOOR MOTOR

< DTC/CIRCUIT DIAGNOSIS >

[MANUAL AIR CONDITIONING]

## INTAKE DOOR MOTOR

### Description

INFOID:000000005490132

#### INTAKE DOOR MOTOR

- The intake door motor (1) is installed to A/C unit assembly.

← : Vehicle front

- The A/C control (built in A/C amp.) sends the control signal to Intake door motor. When intake door motor receives the control signal, intake door is moved to appropriate position.

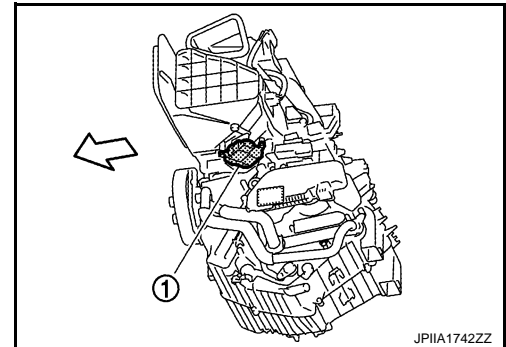

### Diagnosis Procedure

INFOID:000000005490133

#### POWER SUPPLY CIRCUIT

##### 1.CHECK INTAKE DOOR MOTOR DRIVE SIGNAL

- Turn the ignition switch ON.
- Check voltage between intake door motor harness connector and the ground when intake switch is operated.

(+)		(-)	Condition	Voltage (Approx.)
Connector	Terminal	—		
M54	2	Ground	FRE → REC	12 V
	6		REC → FRE	

Is inspection result normal?

- YES >> GO TO 4.  
NO >> GO TO 2.

##### 2.CHECK CONTINUITY BETWEEN A/C CONTROL AND INTAKE DOOR MOTOR

- Turn the ignition switch OFF.
- Disconnect the A/C control connector.
- Disconnect the intake door motor connector.
- Check continuity between A/C control harness connector and intake door motor harness connector.

Intake door motor		A/C control		Continuity
Connector	Terminal	Connector	Terminal	
M54	2	M53	8	Existed
	6		16	

Is inspection result normal?

- YES >> GO TO 3.  
NO >> Repair the harnesses or connectors.

##### 3.CHECK CONTINUITY BETWEEN INTAKE DOOR MOTOR AND GROUND

Check continuity between intake door motor harness connector and the ground.

# INTAKE DOOR MOTOR

< DTC/CIRCUIT DIAGNOSIS >

[MANUAL AIR CONDITIONING]

Intake door motor		—	Continuity
Connector	Terminal		
M54	2	Ground	Not existed
	6		

A

B

Is inspection result normal?

C

YES >> Replace the A/C control.

NO >> Repair the harnesses or connectors.

## 4.CHECK INTAKE DOOR MOTOR

Perform the intake door motor component inspection. Refer to [HAC-171, "Component Inspection"](#).

D

Is inspection result normal?

E

YES >> Replace the A/C control.

NO >> Replace the intake door motor.

## Component Inspection

INFOID:000000005490134

## 1.CHECK INTAKE DOOR MOTOR

F

1. Turn the ignition switch OFF.
2. Disconnect the intake door motor connector.
3. Supply to the intake door motor terminal directly, confirm the motor operation by listening the sound or by visually.

G

H

Terminal		Operation
(+)	(-)	
2	6	To REC
6	2	To FRE

HAC

Is inspection result normal?

J

YES >> INSPECTION END

NO >> Replace the intake door motor.

K

L

M

N

O

P

## THERMO CONTROL AMPLIFIER

### Description

INFOID:000000005490135

#### COMPONENT DESCRIPTION

- Thermo control amp. (1) is composed of thermistor and amplifier. Thermistor is installed on evaporator, and amplifier is attached to foot duct (left).
- When the thermistor detecting temperature which passing through evaporator is extremely low, thermo control amp. sends the thermo control amp. OFF signal to BCM, and stops the compressor.

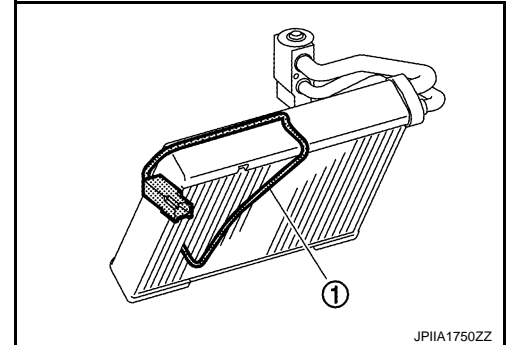

#### OPERATING RATE CONTROL

- Thermo control amp. detects the positions of air temperature control dial and MODE dial.
- Thermo control amp. corrects the stopping temperature of A/C compressor depending on the condition of A/C operation, and prevents too much heating by turning thermo control amp. ON ⇔ OFF.

### Component Function Check

INFOID:000000005490136

#### 1. CHECK THERMO CONTROL AMP. SIGNAL

Ⓟ With CONSULT-III

1. Turn the ignition switch ON.
2. Select the "THERMO AMP" on "DATA MONITOR" in BCM.
3. Check the thermo control amp. signal when the ignition switch is operated.

Monitor item	Condition	Status
THERMO AMP	Ignition switch	ON
		OFF
		On
		Off

Is inspection result normal?

YES >> INSPECTION END

NO >> Refer to [HAC-172, "Diagnosis Procedure"](#).

### Diagnosis Procedure

INFOID:000000005490137

#### 1. CHECK FUSE

Check 10A fuse [NO. 16, located in the fuse block (J/B)].

**NOTE:**

Refer to [PG-97, "Fuse, Connector and Terminal Arrangement"](#).

Is inspection result normal?

YES >> GO TO 2.

NO >> Replace fuse after repairing the applicable circuit.

#### 2. CHECK THERMO CONTROL AMP. POWER SUPPLY CIRCUIT

1. Turn the ignition switch OFF.
2. Disconnect the thermo control amp. connector.
3. Turn the ignition switch ON.
4. Check voltage between thermo control amp. harness connector and the ground.

# THERMO CONTROL AMPLIFIER

< DTC/CIRCUIT DIAGNOSIS >

[MANUAL AIR CONDITIONING]

(+)		(-)	Voltage (Approx.)
Thermo control amp.			
Connector	Terminal	—	
M44	1	Ground	

A

B

Is inspection result normal?

C

YES >> GO TO 3.

NO >> Repair the harness or connector between thermo control amp. and fuse.

### 3. CHECK CONTINUITY THERMO CONTROL AMP. GROUND CIRCUIT

1. Turn the ignition switch OFF.
2. Check continuity between thermo control amp. harness connector and the ground.

D

Thermo control amp.		—	Continuity
Connector	Terminal		
M44	3		
		Existed	

E

F

Is inspection result normal?

YES >> GO TO 4.

NO >> Repair the harnesses or connectors.

G

### 4. CHECK VOLTAGE BETWEEN THERMO CONTROL AMP. AND GROUND

1. Turn the ignition switch ON.
2. Check voltage between thermo control amp. harness connector and the ground.

H

(+)		(-)	Voltage (Approx.)
Thermo control amp.			
Connector	Terminal	—	
M44	2	Ground	

HAC

J

Is inspection result normal?

YES >> Replace the thermo control amp.

NO >> GO TO 5.

K

### 5. CHECK CONTINUITY BETWEEN THERMO CONTROL AMP. AND BCM

1. Turn the ignition switch OFF.
2. Disconnect the BCM connector.
3. Check continuity between thermo control amp. harness connector and BCM harness connector.

L

Thermo control amp.		BCM		Continuity
Connector	Terminal	Connector	Terminal	
M44	2	M65	26	

M

N

Is inspection result normal?

YES >> GO TO 6.

NO >> Repair the harnesses or connectors.

O

### 6. CHECK CONTINUITY BETWEEN THERMO CONTROL AMP. AND GROUND

Check continuity between thermo control amp. harness connector and the ground.

P

Thermo control amp.		—	Continuity
Connector	Terminal		
M44	2		
		Not existed	

Is inspection result normal?

## THERMO CONTROL AMPLIFIER

< DTC/CIRCUIT DIAGNOSIS >

[MANUAL AIR CONDITIONING]

---

YES >> Repair the harnesses or connectors.  
NO >> INSPECTION END

## BLOWER MOTOR

### Description

INFOID:000000005490138

### COMPONENT DESCRIPTION

#### Blower Motor

- The blower motor is installed in the RH side of A/C unit assembly.
- The blower motor adopts the forcible air cooling system and one-touch installation system without any screws.

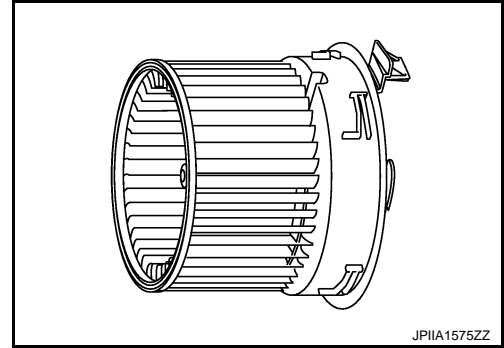

#### Blower Fan Resistor

- Compact and lightweight resistor is adopted with outstanding ventilation.
- Temperature fuse is installed to protect the blower motor circuit.

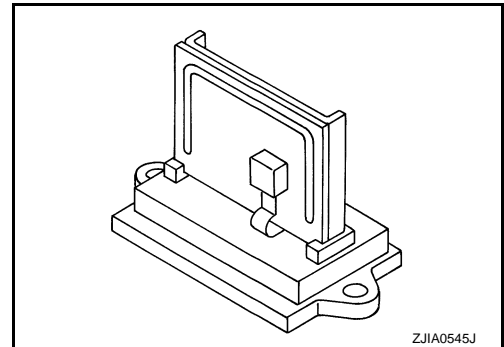

### Diagnosis Procedure

INFOID:000000005490139

#### 1. CHECK FUSE

Check 15A fuses [Nos. 15 and 17, located in the fuse block (J/B)].

**NOTE:**

Refer to [PG-97, "Fuse, Connector and Terminal Arrangement"](#).

Is the inspection result normal?

YES >> GO TO 2.

NO >> Replace fuse after repairing the applicable circuit.

#### 2. CHECK POWER SUPPLY FOR BLOWER MOTOR

1. Turn the ignition switch OFF.
2. Disconnect the blower motor connector.
3. Turn the ignition switch ON.
4. Check voltage between blower motor harness connector and the ground.

(+)		(-)	Voltage (Approx.)
Blower motor		—	
Connector	Terminal	Ground	
M39	1		Battery voltage

Is the inspection result normal?

YES >> GO TO 3.

NO >> GO TO 4.

#### 3. CHECK BLOWER RELAY

A  
B  
C  
D  
E  
F  
G  
H  
HAC  
J  
K  
L  
M  
N  
O  
P

# BLOWER MOTOR

[MANUAL AIR CONDITIONING]

## < DTC/CIRCUIT DIAGNOSIS >

1. Turn the ignition switch OFF.
2. Perform the component inspection of blower motor relay. Refer to [HAC-177, "Component Inspection"](#).

Is the inspection result normal?

- YES >> Replace the harness or connector between blower motor and fuse.  
NO >> Replace the blower relay.

### 4. CHECK FAN SWITCH GROUND CIRCUIT

1. Turn the ignition switch OFF.
2. Disconnect the fan switch connector.
3. Check continuity between fan switch harness connector and the ground.

Fan switch		—	Continuity
Connector	Terminal		
M73	3	Ground	Existed

Is the inspection result normal?

- YES >> GO TO 5.  
NO >> Repair the harness or connector.

### 5. CHECK CONTINUITY BETWEEN FAN SWITCH AND BLOWER MOTOR

Check continuity fan switch harness connector and blower motor harness connector.

Fan switch		Blower motor		Continuity
Connector	Terminal	Connector	Terminal	
M73	5	M39	2	Existed

Is the inspection result normal?

- YES >> GO TO 6.  
NO >> Repair the harness or connector.

### 6. CHECK VOLTAGE BETWEEN BLOWER FAN RESISTOR AND GROUND

1. Disconnect the blower fan resistor connector.
2. Turn the ignition switch ON.
3. Check voltage between blower fan resistor harness connector and the ground.

(+)		(-)		Voltage (Approx.)
Blower fan resistor		—		
Connector	Terminal			
M306	3	Ground		12 V

Is the inspection result normal?

- YES >> GO TO 7.  
NO >> Repair the harness or connector between blower fan resistor and blower motor.

### 7. CHECK BLOWER FAN RESISTOR

1. Turn the ignition switch OFF.
2. Perform the component inspection of blower fan resistor. Refer to [HAC-177, "Component Inspection"](#).

Is the inspection result normal?

- YES >> GO TO 8.  
NO >> Replace the blower fan resistor.

### 8. CHECK CIRCUIT CONTINUITY BETWEEN FAN SWITCH AND BLOWER FAN RESISTOR

Check continuity between fan switch harness connector and blower fan resistor.



# BLOWER MOTOR

< DTC/CIRCUIT DIAGNOSIS >

[MANUAL AIR CONDITIONING]

Fan switch		Blower fan resistor		Continuity
Connector	Terminal	Connector	Terminal	
M73	4	M306	4	Existed
	1		1	
	2		2	

Is the inspection result normal?

- YES >> GO TO 9.
- NO >> Repair the harness or connector.

## 9.CHECK FAN SWITCH

Perform the component inspection of fan switch. Refer to [HAC-177. "Component Inspection"](#).

Is the inspection result normal?

- YES >> Replace the blower motor.
- NO >> Replace the fan switch (A/C control).

## Component Inspection

INFOID:000000005490140

## BLOWER MOTOR

### 1.CHECK BLOWER MOTOR

1. Remove the blower motor. Refer to [VTL-13. "Exploded View"](#).
2. Check that there is not any mixing foreign object in the blower motor.

Is the inspection result normal?

- YES >> GO TO 2.
- NO >> Replace the blower motor.

### 2.CHECK BLOWER MOTOR

Check that there is not breakage or damage in the blower motor.

Is the inspection result normal?

- YES >> GO TO 3.
- NO >> Replace the blower motor.

### 3.CHECK BLOWER MOTOR

Check that the blower motor turns smoothly.

Is the inspection result normal?

- YES >> INSPECTION END
- NO >> Replace the blower motor.

## BLOWER MOTOR RELAY

### 1.CHECK BLOWER MOTOR

1. Remove the blower motor relay. Refer to [PG-97. "Fuse, Connector and Terminal Arrangement"](#).
2. Check the continuity between the blower motor relay terminal 3 and 5 when the voltage is supplied between terminal 1 and 2.

Blower motor relay		Voltage	Continuity
Terminal			
3	5	ON	Existed
		OFF	Not existed

Is the inspection result normal?

- YES >> INSPECTION END
- NO >> Replace the blower motor relay.

## BLOWER FAN RESISTOR

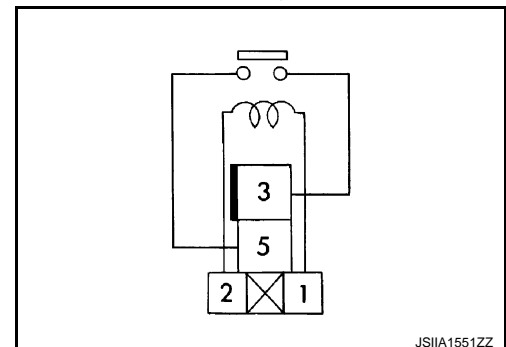

# BLOWER MOTOR

< DTC/CIRCUIT DIAGNOSIS >

[MANUAL AIR CONDITIONING]

## 1. CHECK BLOWER MOTOR

1. Turn the ignition switch OFF.
2. Disconnect the blower fan resistor connector.
3. Check the resistance between blower fan resistor terminals. Refer to the applicable table for the normal value.

Blower fan resistor		Resistance: $\Omega$ (Approx.)
Terminal		
3	4	0.43
	1	1.03
	2	3

Is the inspection result normal?

YES >> INSPECTION END

NO >> Replace the blower fan resistor.

## FAN SWITCH

### 1. CHECK FAN SWITCH

1. Turn the ignition switch OFF.
2. Disconnect the fan switch connector.
3. Check the fan switch circuit continuity.

Fan switch		Condition	Continuity
Terminal		Dial position	
3	2	1st	Existed
	1	2nd	
	4	3rd	
	5	4th	

Is the inspection result normal?

YES >> INSPECTION END

NO >> Replace the fan switch (A/C control).

## MAGNET CLUTCH

### Description

INFOID:000000005490141

- The magnet clutch is the device that drives the compressor with the signal from IPDM E/R.
- Compressor is driven by the magnet clutch which is charged magnetic force by electrified.
- IPDM E/R controls magnet clutch by turning the built in A/C relay to ON ⇔ OFF according to ECM request.

### Component Function Check

INFOID:000000005490142

#### 1.PERFORM AUTO ACTIVE TEST

Perform IPDM E/R auto active test. Refer to [PCS-41, "Diagnosis Description"](#).

Does the magnet clutch operate?

- YES >> INSPECTION END  
 NO >> Refer to [HAC-179, "Diagnosis Procedure"](#).

### Diagnosis Procedure

INFOID:000000005490143

#### 1.CHECK MAGNET CLUTCH

1. Turn the ignition switch OFF.
2. Disconnect the magnet clutch connector.
3. Directly apply the battery voltage to the magnet clutch. Check for operation visually and by sound.

Does it operate normally?

- YES >> GO TO 2.  
 NO >> Replace the compressor.

#### 2.CHECK MAGNET CLUTCH CIRCUIT CONTINUITY

1. Turn the ignition switch OFF.
2. Disconnect the IPDM E/R connector.
3. Check continuity between magnet clutch harness connector and IPDM E/R harness connector.

IPDM E/R		Magnet clutch		Continuity
Connector	Terminal	Connector	Terminal	
E15	56	F17	1	Existed

Is the inspection result normal?

- YES >> GO TO 3.  
 NO >> Repair the harnesses and connectors.

#### 3.CHECK FUSE

Check 10A fuse (No. 49, located in the IPDM E/R).

**NOTE:**

Refer to [PG-99, "Fuse, Connector and Terminal Arrangement"](#).

Is the inspection result normal?

- YES >> Replace the IPDM E/R.  
 NO >> Replace the fuse after repairing the applicable circuit.

A  
B  
C  
D  
E  
F  
G  
H  
J  
K  
L  
M  
N  
O  
P

HAC

## A/C SWITCH

### Description

INFOID:000000005490144

- Each signal is sent to BCM by pressing the A/C switch.
- BCM judges the recognition that A/C switch is ON or OFF according to input switch signal.

### Component Function Check

INFOID:000000005490145

#### 1. CHECK A/C SWITCH SIGNAL

Ⓟ With CONSULT-III

1. Turn the ignition switch ON.
2. Select the "AIR COND SW" on "DATA MONITOR" in BCM.
3. Check the A/C switch signal when A/C switch is operated.

Monitor item	Condition	Status
AIR COND SW	A/C switch	
	While pushing	On
	While not pushing	Off

Is inspection result normal?

- YES >> INSPECTION END  
 NO >> Refer to [HAC-180, "Diagnosis Procedure"](#).

### Diagnosis Procedure

INFOID:000000005490146

#### 1. CHECK A/C SWITCH SIGNAL OUTPUT

1. Turn the ignition switch OFF.
2. Disconnect the A/C control connector.
3. Turn the ignition switch ON.
4. Check output waveform between A/C switch harness connector and the ground with using oscilloscope.

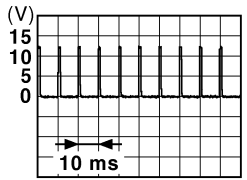
(+)		(-)	Output waveform
A/C control		—	
Connector	Terminal		
M53	12	Ground	 <p style="text-align: right; font-size: small;">JPMA0012GB Approx. 1.0 ~ 1.5 V</p>

Is inspection result normal?

- YES >> GO TO 2.  
 NO >> GO TO 3.

#### 2. CHECK CONTINUITY A/C CONTROL GROUND CIRCUIT

1. Turn the ignition switch OFF.
2. Check continuity between A/C control harness connector and the ground.

A/C control		—	Continuity
Connector	Terminal		
M53	15	Ground	Existed

Is inspection result normal?

# A/C SWITCH

[MANUAL AIR CONDITIONING]

< DTC/CIRCUIT DIAGNOSIS >

YES >> Replace the A/C switch (A/C control).

NO >> Repair the harness or connector.

## 3. CHECK CONTINUITY BETWEEN A/C CONTROL AND BCM

1. Turn the ignition switch OFF.
2. Disconnect the BCM connector.
3. Check continuity between A/C control harness connector and BCM harness connector.

A/C control		BCM		Continuity
Connector	Terminal	Connector	Terminal	
M53	12	M65	27	Existed

Is inspection result normal?

YES >> GO TO 4.

NO >> Repair the harness or connector.

## 4. CHECK CONTINUITY BETWEEN A/C CONTROL AND GROUND

Check continuity between A/C control harness connector and the ground.

A/C control		—	Continuity
Connector	Terminal		
M53	12	Ground	Not existed

Is inspection result normal?

YES >> Replace the BCM. Refer to [BCS-146. "Exploded View"](#).

NO >> Repair the harness or connector.

A  
B  
C  
D  
E  
F  
G  
H  
J  
K  
L  
M  
N  
O  
P

HAC

# DEFROSTER POSITION SIGNAL

< DTC/CIRCUIT DIAGNOSIS >

[MANUAL AIR CONDITIONING]

## DEFROSTER POSITION SIGNAL

### Description

INFOID:000000005490147

- Each signal is sent to BCM by setting the D/F or DEF position.
- BCM judges the change of the air inlet and recognition of A/C switch ON or OFF according to input switch signal.

### Component Function Check

INFOID:000000005490148

#### 1. CHECK DEFROSTER POSITION SIGNAL

Ⓜ With CONSULT-III

1. Turn the ignition switch ON.
2. Select the "FR DEF SW" on "DATA MONITOR" in BCM.
3. Check the A/C switch signal when A/C switch is operated.

Monitor item	Condition		Status
FR DEF SW	MODE position	D/F or DEF	On
		VENT, B/L or FOOT	Off

Is inspection result normal?

YES >> INSPECTION END

NO >> Refer to [HAC-182. "Diagnosis Procedure"](#).

### Diagnosis Procedure

INFOID:000000005490149

#### 1. CHECK VOLTAGE BETWEEN A/C CONTROL AND GROUND

1. Turn the ignition switch OFF.
2. Disconnect the A/C control connector.
3. Turn the ignition switch ON.
4. Check voltage between A/C control harness connector and the ground.

(+)		(-)	Voltage (Approx.)
Connector	Terminal		
M53	6	Ground	12 V

Is inspection result normal?

YES >> Replace the A/C control.

NO >> GO TO 2.

#### 2. CHECK CONTINUITY BETWEEN A/C CONTROL AND BCM

1. Turn the ignition switch OFF.
2. Disconnect the BCM connector.
3. Check continuity between A/C control harness connector and BCM harness connector.

A/C control		BCM		Continuity
Connector	Terminal	Connector	Terminal	
M53	6	M66	31	Existed

Is inspection result normal?

YES >> GO TO 3.

NO >> Repair the harness or connector.

#### 3. CHECK CONTINUITY BETWEEN A/C CONTROL AND GROUND

Check continuity between A/C control harness connector and the ground.

# DEFROSTER POSITION SIGNAL

< DTC/CIRCUIT DIAGNOSIS >

[MANUAL AIR CONDITIONING]

A/C control		—	Continuity
Connector	Terminal		
M53	6	Ground	Not existed

Is inspection result normal?

YES >> Replace the BCM. Refer to [BCS-146. "Exploded View"](#).

NO >> Repair the harness or connector.

A  
B  
C  
D  
E  
F  
G  
H  
J  
K  
L  
M  
N  
O  
P

HAC

## A/C INDICATOR

### Component Function Check

INFOID:000000005490150

#### 1. PERFORM AUTO ACTIVE TEST OF A/C INDICATOR

Ⓟ With CONSULT-III

1. Select the "AIR COND IND" on "ACTIVE TEST" in BCM.
2. Check the A/C indicator status.

**On** : A/C indicator ON  
**Off** : A/C indicator OFF

Is inspection result normal?

- YES >> INSPECTION END  
 NO >> Refer to [HAC-184, "Diagnosis Procedure"](#).

### Diagnosis Procedure

INFOID:000000005490151

#### 1. DEFINE THE MALFUNCTION

Define the A/C indicator malfunction.

- A/C indicator dose not turn ON>>GO TO 2.  
 A/C indicator dose not turn OFF>>GO TO 6.

#### 2. CHECK FUSE

Check 10A fuse [No. 16, located in the fuse block (J/B)].

**NOTE:**  
 Refer to [PG-97, "Fuse, Connector and Terminal Arrangement"](#).

Is inspection result normal?

- YES >> GO TO 3.  
 NO >> Replace fuse after repairing the applicable circuit.

#### 3. CHECK VOLTAGE BETWEEN A/C CONTROL POWER SUPPLY

1. Turn the ignition switch ON.
2. Check voltage between A/C control harness connector and the ground.

(+)		(-)	Voltage
A/C control		—	
Connector	Terminal	Ground	Battery voltage
M53	14		

Is inspection result normal?

- YES >> GO TO 4.  
 NO >> Repair the harness or connector between A/C control and fuse.

#### 4. CHECK VOLTAGE BETWEEN A/C CONTROL AND GROUND

Check voltage between A/C control harness connector and the ground.

(+)		(-)	Voltage (Approx.)
A/C control		—	
Connector	Terminal	Ground	12 V
M53	13		

Is inspection result normal?

- YES >> GO TO 5.  
 NO >> Replace the A/C control (A/C indicator).



# A/C INDICATOR

< DTC/CIRCUIT DIAGNOSIS >

[MANUAL AIR CONDITIONING]

## 5. CHECK CONTINUITY BETWEEN A/C CONTROL AND BCM

1. Turn the ignition switch OFF.
2. Disconnect the A/C control connector.
3. Disconnect the BCM connector.
4. Check continuity between A/C control harness connector and BCM harness connector.

A/C control		BCM		Continuity
Connector	Terminal	Connector	Terminal	
M53	13	M66	50	Existed

Is inspection result normal?

YES >> GO TO 6.

NO >> Repair the harness or connector.

## 6. CHECK CONTINUITY BETWEEN A/C CONTROL AND GROUND

1. Check continuity between A/C control harness connector and the ground.

A/C control		—	Continuity
Connector	Terminal		
M53	13	Ground	Not existed

Is inspection result normal?

YES >> Replace the BCM. Refer to [BCS-146, "Exploded View"](#).

NO >> Repair the harness or connector.

A  
B  
C  
D  
E  
F  
G  
H  
J  
K  
L  
M  
N  
O  
P

HAC

# BLOWER FAN ON SIGNAL

< DTC/CIRCUIT DIAGNOSIS >

[MANUAL AIR CONDITIONING]

## BLOWER FAN ON SIGNAL

### Component Function Check

INFOID:000000005490152

#### 1.CHECK BLOWER FAN ON SIGNAL

④ With CONSULT-III

1. Turn the ignition switch ON.
2. Select the "FAN ON SIG" on "DATA MONITOR" in BCM.
3. Check the fan ON signal when the fan control dial is operated.

Monitor item	Condition	Status
FAN ON SIG	Fan control dial OFF position	Off
	Except OFF position	On

Is inspection result normal?

YES >> INSPECTION END

NO >> Refer to [HAC-186, "Diagnosis Procedure"](#).

### Diagnosis Procedure

INFOID:000000005490153

#### 1.CHECK BLOWER FAN ON SIGNAL OUTPUT

1. Turn the ignition switch OFF.
2. Disconnect the fan switch connector.
3. Turn the ignition switch ON.
4. Check output waveform between fan switch harness connector and the ground with using oscilloscope.

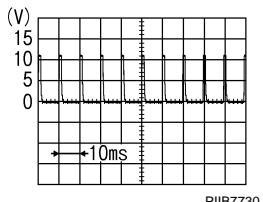
(+)		(-)	Output waveform
Fan switch		—	
Connector	Terminal		
M73	6	Ground	 Approx. 1.5 ~ 2.0 V

Is inspection result normal?

YES >> Replace the fan switch (A/C control).

NO >> GO TO 2.

#### 2.CHECK CONTINUITY BETWEEN FAN SWITCH AND BCM

1. Turn the ignition switch OFF.
2. Disconnect the BCM connector.
3. Check continuity between fan switch harness connector and BCM harness connector.

Fan switch		BCM		Continuity
Connector	Terminal	Connector	Terminal	
M73	6	M65	28	Existed

Is inspection result normal?

YES >> GO TO 3.

NO >> Repair the harness or connector.

#### 3.CHECK CONTINUITY BETWEEN FAN SWITCH AND GROUND

# BLOWER FAN ON SIGNAL

< DTC/CIRCUIT DIAGNOSIS >

[MANUAL AIR CONDITIONING]

Check continuity between fan switch harness connector and the ground.

Fan switch		—	Continuity
Connector	Terminal		
M73	6	Ground	Not existed

Is inspection result normal?

- YES >> Replace the BCM. Refer to [BCS-146. "Exploded View"](#).
- NO >> Repair the harness or connector.

A  
B  
C  
D  
E  
F  
G  
H  
J  
K  
L  
M  
N  
O  
P

HAC

# MANUAL AIR CONDITIONING SYSTEM

< DTC/CIRCUIT DIAGNOSIS >

[MANUAL AIR CONDITIONING]

## MANUAL AIR CONDITIONING SYSTEM

### Wiring Diagram — MANUAL AIR CONDITIONING SYSTEM —

INFOID:000000005490154

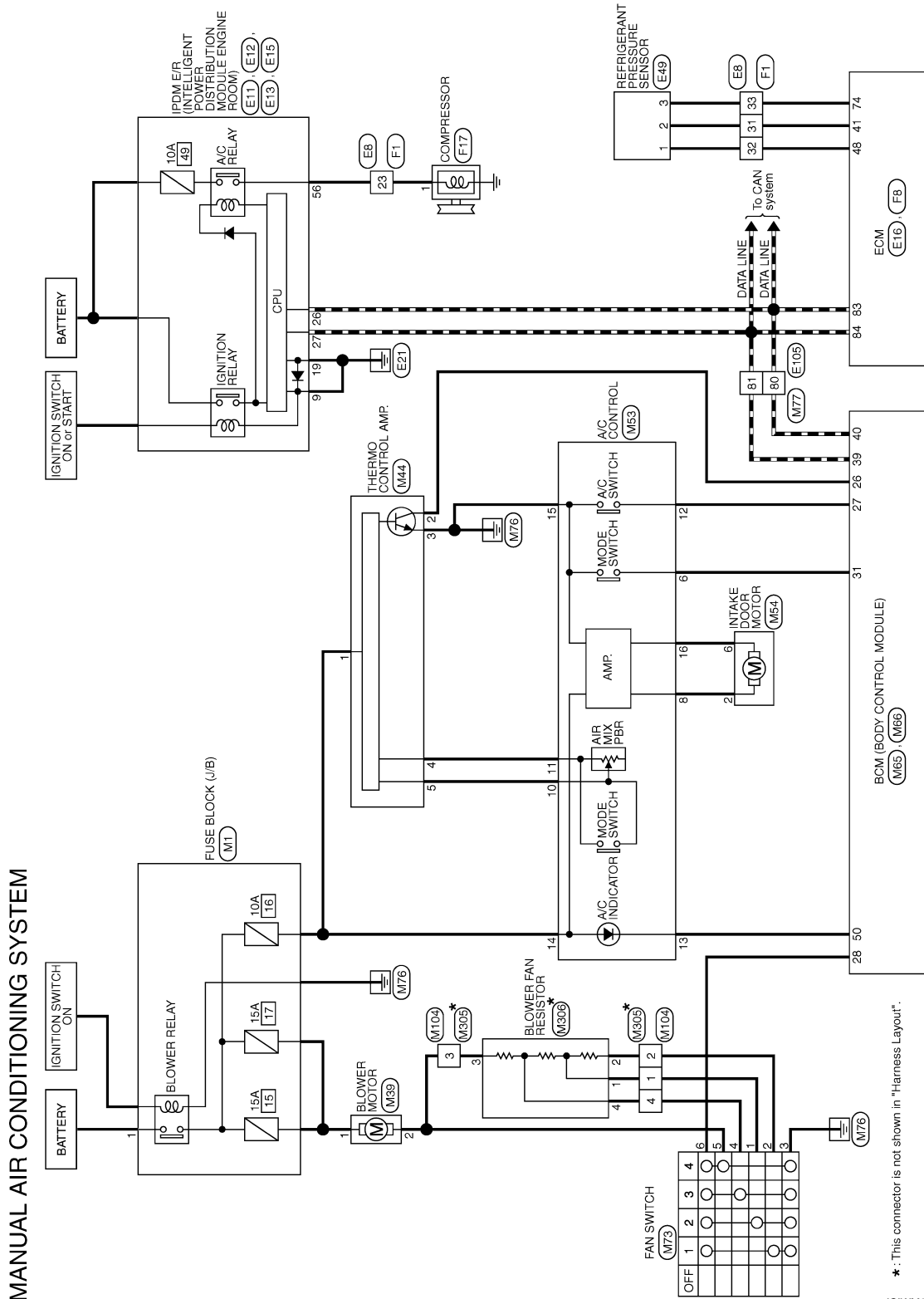

\*: This connector is not shown in "Harness Layout".

2009/10/02

JCIWM0615GB

# MANUAL AIR CONDITIONING SYSTEM

< DTC/CIRCUIT DIAGNOSIS >

[MANUAL AIR CONDITIONING]

## MANUAL AIR CONDITIONING SYSTEM

Connector No.	EB
Connector Name	WIRE TO WIRE
Connector Type	SAC30MB-RS10-SJZZ

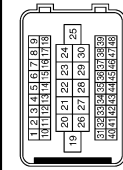

Terminal No.	Color of Wire	Signal Name [Specification]
1	BR	-
2	LG	-
3	Y	-
4	W	-
7	Y	-
8	SB	-
9	L	-
10	V	-
11	P	-
12	BR	-
13	LG	-
14	Y	-
15	SB	-
16	L	-
17	W	-
18	O	-
21	G	-
23	SB	-
24	W	-
25	BR	-
26	B	-
27	GR	-
28	P	-
29	V	-
30	G	-
31	G	-
32	O	-
33	W	-
34	Y	-
35	V	-
36	P	-
37	LG	-
39	SB	-
40	GR	-
41	O	-
42	V	-
43	R	- [With CVT] - [With M/T]
43	LG	- [With M/T]

44	R	-
46	W	-
47	C	-
48	BR	-

Connector No.	E11
Connector Name	SPM E/R INTELLIGENT POWER DISTRIBUTION MODULE (ENGINE ROOM)
Connector Type	MODFB-LC

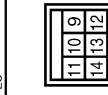

Terminal No.	Color of Wire	Signal Name [Specification]
9	B/W	-
10	L	-
13	W	-

Connector No.	E12
Connector Name	SPM E/R INTELLIGENT POWER DISTRIBUTION MODULE (ENGINE ROOM)
Connector Type	NSD0FER-CS

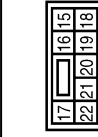

Terminal No.	Color of Wire	Signal Name [Specification]
18	Y	-
19	B/W	-
21	W	-
22	V	-

Connector No.	E13
Connector Name	SPM E/R INTELLIGENT POWER DISTRIBUTION MODULE (ENGINE ROOM)
Connector Type	TH12FN-NH

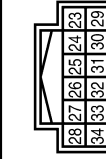

Terminal No.	Color of Wire	Signal Name [Specification]
24	LG	-
25	Y	-
26	P	-
27	L	-
28	P	-
30	SB	-
31	W	-
33	O	-
34	R	-

Connector No.	E15
Connector Name	SPM E/R INTELLIGENT POWER DISTRIBUTION MODULE (ENGINE ROOM)
Connector Type	NS18FW-CS

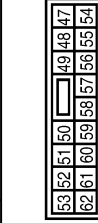

Terminal No.	Color of Wire	Signal Name [Specification]
47	BR	-
49	W	-
50	GR	-
51	R	-
52	P	-
54	GR	-
55	P	-
56	SB	-
57	G	-
58	R	- [With CVT]
58	Y	- [With M/T]
59	Y	-
60	V	-

61	W	-
62	L	-

Connector No.	E16
Connector Name	ECM
Connector Type	RH24FB-R23-L-RH

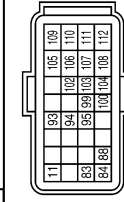

Terminal No.	Color of Wire	Signal Name [Specification]
83	P	CAN-L
84	L	CAN-H
88	LG	K LINE
93	L	IGNSW
94	SB	ASCDSW
95	BR	GND-ASCDSW
99	W	BRAKE
100	SB	BNGSW
102	O	AVCC-APSZ
103	G	APSZ
104	R	GND-APSZ
105	G	VBR
106	V	AVCC-APSI
108	B	GND
110	BR	APSI
111	Y	GND-APSI

A  
B  
C  
D  
E  
F  
G  
H  
HAC  
J  
K  
L  
M  
N  
O  
P

# MANUAL AIR CONDITIONING SYSTEM

< DTC/CIRCUIT DIAGNOSIS >

[MANUAL AIR CONDITIONING]

## MANUAL AIR CONDITIONING SYSTEM

Connector No.	E49
Connector Name	REFRIGERANT PRESSURE SENSOR
Connector Type	RK03FB



Terminal No.	Color of Wire	Signal Name [Specification]
1	O	-
2	G	-
3	W	-

Connector No.	E105
Connector Name	WIRE TO WIRE
Connector Type	TH80MW-CS (S-TM4)

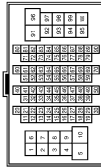

Terminal No.	Color of Wire	Signal Name [Specification]
1	V	-
2	W	-
3	SB	-
4	G	-
5	P	-
6	R	-
7	Y	-
8	O	-
9	W	-
10	SB	-
31	V	-
32	R	-
33	GR	-
34	P	-
35	Y	-
36	BR	-
39	SB	-
44	R	-
45	V	-

46	P	-
47	W	-
48	L	-
49	Y	-
50	W	-
51	BR	- [Wht. CVT]
51	B	- [Wht. M/T]
53	SB	-
54	W	- [Wht. CVT]
54	O	- [Wht. M/T]
57	LG	-
59	L	-
60	O	-
61	G	-
62	W	-
63	L	-
67	GR	- [Wht. CVT]
67	V	- [Wht. M/T]
69	P	-
70	SHIELD	-
71	GR	-
72	LG	-
73	P	-
74	V	-
76	Y	-
77	LG	-
78	O	-
79	G	-
80	P	-
81	L	-
82	W	-
83	BR	-
84	B	-
87	GR	-
91	W	-
92	Y	-
93	Y	-
94	R	-
95	LG	-
96	R	-
97	R	-
98	SB	-
99	G	-
100	P	-

Connector No.	F1
Connector Name	WIRE TO WIRE
Connector Type	SA03FB-RS (P-SJ22)

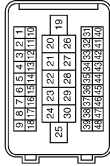

Terminal No.	Color of Wire	Signal Name [Specification]
1	SB	-
2	LG	-
3	R	-
4	Y	-
7	V	-
8	G	-
9	SB	-
10	L	-
11	Y	-
12	GR	-
13	BR	-
14	G	-
15	W	-
16	Y	-
17	P	-
18	BR	-
21	G	-
23	W	-
24	R	-
25	R	-
26	B	-
27	SB	-
28	V	-
28	V	-
29	BR	-
30	GR	-
31	GR	-
32	BR	-
33	W	-
34	LG	-
35	V	-
36	Y	-
37	W	-
39	G	-
40	P	-
41	O	-
42	G	-
43	R	-
44	P	-

46	GR
47	Y
48	BR

# MANUAL AIR CONDITIONING SYSTEM

< DTC/CIRCUIT DIAGNOSIS >

[MANUAL AIR CONDITIONING]

## MANUAL AIR CONDITIONING SYSTEM

Connector No.	F8
Connector Name	ECM
Connector Type	RH40FB-R28-L-RH

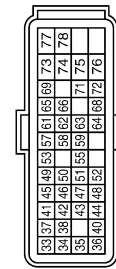

Terminal No.	Color of Wire	Signal Name [Specification]
33	LG	TFS 1
34	R	TFS 2
36	Y	GND-A-TFS
37	W	TKK
38	BR	TW
40	SHIELD	GND-A-KKK
41	GR	PDIPRES
42	V	FTPRES
43	P	TF
44	GR	GND-A-TW
45	G	QA+
46	L	TA
48	BR	GND-A-PDPRES
49	V	AF+
50	W	OZSR
51	Y	GND-A-FTPRES
52	R	QA-
53	LG	AF-
55	P	GND-A-TA
58	GR	CURSEN
59	O	GND-A-OZSR
61	W	POS
62	R	GND-POS
63	BR	GND-PHASE
65	G	PHASE
68	SB	GND-CURSEN
69	L	NEUT-H
72	O	AVCC-TFS
73	P	GVTC
74	W	AVCC-PDPRES
75	BR	AVCC-POS
76	LG	AVCC-FTPRES
77	Y	AVCC-CURSEN
78	O	AVCC-PHASE

Connector No.	F17
Connector Name	COMPRESSOR
Connector Type	RS01FB

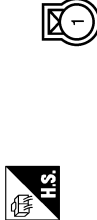

Terminal No.	Color of Wire	Signal Name [Specification]
1	W	MAGNET CLUTCH POWER SUPPLY

Connector No.	M1
Connector Name	FUSE BLOCK (J/B)
Connector Type	-



Terminal No.	Color of Wire	Signal Name [Specification]
1	W	-

Connector No.	M39
Connector Name	BLOWER MOTOR
Connector Type	TM02FW



Terminal No.	Color of Wire	Signal Name [Specification]
1	Y	BLOWER MOTOR POWER SUPPLY
2	R	BLOWER MOTOR CONTROL SIGNAL [With auto A/C]
2	L	SENSOR GROUND [Except with auto A/C]

Connector No.	M44
Connector Name	THERMO CONTROL AMP.
Connector Type	S08FW



Terminal No.	Color of Wire	Signal Name [Specification]
1	Y	-
2	GR	-
3	BR	-
4	V	-
5	B/W	-

Connector No.	M53
Connector Name	A/C CONTROL
Connector Type	TH16FW-NH

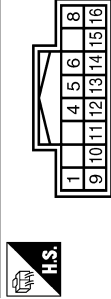

Terminal No.	Color of Wire	Signal Name [Specification]
1	W	-
4	R	-
5	W/L	-
6	G/Y	-
8	G	-
9	B/R	-
10	B/W	-
11	V	-
12	Y/R	-
13	SB	-
14	Y	-
15	B	-
16	L	-

Connector No.	M54
Connector Name	INTAKE DOOR MOTOR
Connector Type	RS13P-0001



Terminal No.	Color of Wire	Signal Name [Specification]
1	R	INTAKE DOOR MOTOR PBR POWER SUPPLY
2	SB	INTAKE DOOR MOTOR PBR F/B SIGNAL [With auto A/C]
3	R/W	INTAKE DOOR MOTOR PBR F/B SIGNAL [Except with auto A/C]
5	G	GROUND
6	L	REC DRIVE SIGNAL

A  
B  
C  
D  
E  
F  
G  
H  
HAC  
J  
K  
L  
M  
N  
O  
P

# MANUAL AIR CONDITIONING SYSTEM

< DTC/CIRCUIT DIAGNOSIS >

[MANUAL AIR CONDITIONING]

## MANUAL AIR CONDITIONING SYSTEM

Connector No.	M65
Connector Name	BCM (BODY CONTROL MODULE)
Connector Type	TH4DFW-NH

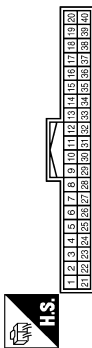

Terminal No.	Color of Wire	Signal Name [Specification]
2	BR/W	COMBI SW INPUT 5
3	GR	COMBI SW INPUT 4
4	L/Y	COMBI SW INPUT 3
5	G	COMBI SW INPUT 2
6	L/R	COMBI SW INPUT 1
7	W/B	KEY CYL UNLOCK SW
8	W/B	KEY CYL LOCK SW
9	R	STOP LAMP SW
10	W/L	REAR WINDOW DEFOGGER SW
11	L/Y	ACC
12	SB	PASSENGER DOOR SW
13	GR/L	REAR RH DOOR SW
14	L/B	OPTICAL SENSOR
15	V/W	TIRE PRESS WARNING CHECK SW
17	R/G	OPTICAL SENSOR POWER SUPPLY RECEIVER/SENSOR GND
18	V	REAR WIPER STOP POSITION
19	BR	KEYLESS ENTRY RECEIVER POWER SUPPLY
20	G/Y	KEYLESS ENTRY RECEIVER COMM
21	P/L	NATS ANTENNA AMP
23	R/Y	SECURITY INDICATOR LAMP
24	GR/R	DONGLE LINK
25	LG	NATS ANTENNA AMP
26	GR	THERMO CONTROL AMP
27	Y/G	A/C SW [With auto A/C]
27	Y/R	A/C SW [With manual A/C]
28	G/W	BLOWER FAN SW
28	L/W	HAZARD SW
31	G/Y	FR DEFROSTER SW
32	LG	COMBI SW OUTPUT 5
33	Y/L	COMBI SW OUTPUT 4
34	W	COMBI SW OUTPUT 3
35	R/L	COMBI SW OUTPUT 2
36	L/O	COMBI SW OUTPUT 1
37	R/W	KEY SWITCH
38	O	IGN
39	L	CAN-H
40	P	CAN-L

Connector No.	M66
Connector Name	BCM (BODY CONTROL MODULE)
Connector Type	FE4GBFW-FHA6-SA

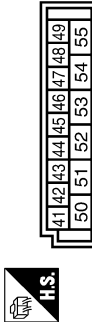

Terminal No.	Color of Wire	Signal Name [Specification]
43	W	BACK DOOR SW
44	LG	REAR WIPER STOP POSITION
45	GR	CENTRAL DOOR LOCK SW
46	BR	CENTRAL DOOR UNLOCK SW
47	BR/Y	DRIVER DOOR SW
48	W/G	REAR LH DOOR SW
50	SB	A/C INDICATOR OUTPUT
54	L/W	REAR WIPER OUTPUT

Connector No.	M73
Connector Name	FAN SWITCH
Connector Type	MD6FW-LC



Terminal No.	Color of Wire	Signal Name [Specification]
1	R	
2	W	
3	B	
4	Y	
5	L	
6	G/W	

Connector No.	M77
Connector Name	WIRE TO WIRE
Connector Type	TH6BFW-CS16-TM4



Terminal No.	Color of Wire	Signal Name [Specification]
1	B/O	
2	R	
3	G/R	
4	G/B	
5	L	
6	L	
7	W/R	
8	G/W	
9	Y/L	
10	W	
31	GR/L	
32	L/B	
33	R/Y	
34	SB	
35	BR	
36	G	
39	L/R	
44	G/O	
45	LG/R	
46	GR/W	
47	BR/Y	
48	L/O	
48	L/W	
50	P/L	
51	B/W	
53	R/L	
54	O	
57	GR	
59	V	
60	R/W	
61	V/W	
62	W/L	
63	W/B	
67	Y/R	
69	LG	
70	SHIELD	
71	P/B	
72	R/G	

73	R	
74	L/Y	
76	W/G	
77	GR/R	
78	O	
79	LG	
80	P	
81	L	
82	GR	
83	G/R	
84	B	
87	G	
91	R	
92	O	
93	Y	
94	R/B	
95	L/W	
96	Y	
97	L	
98	BR/W	
99	W	
100	G/R	

Connector No.	MTD4
Connector Name	WIRE TO WIRE
Connector Type	MM4FW-LC



Terminal No.	Color of Wire	Signal Name [Specification]
1	R	
2	W	
3	L	
4	Y	

JCIWM0619GB



# MANUAL AIR CONDITIONING SYSTEM

< DTC/CIRCUIT DIAGNOSIS >

[MANUAL AIR CONDITIONING]

A  
B  
C  
D  
E  
F  
G  
H  
HAC  
J  
K  
L  
M  
N  
O  
P

## MANUAL AIR CONDITIONING SYSTEM

Connector No.	M335
Connector Name	WIRE TO WIRE
Connector Type	MDMMW



Terminal No.	Color of Wire	Signal Name [Specification]
1	G	-
2	Y	-
3	R	-
4	L	-

Connector No.	M336
Connector Name	BLOWER FAN RESISTOR
Connector Type	TM04FW-1V



Terminal No.	Color of Wire	Signal Name [Specification]
1	G	-
2	Y	-
3	R	-
4	L	-

JCIWM0620GB

# BCM (BODY CONTROL MODULE)

< ECU DIAGNOSIS INFORMATION >

[MANUAL AIR CONDITIONING]

## ECU DIAGNOSIS INFORMATION

### BCM (BODY CONTROL MODULE)

Reference Value

INFOID:000000005819864

#### VALUES ON THE DIAGNOSIS TOOL

Monitor Item	Condition	Value/Status
IGN ON SW	Ignition switch OFF or ACC	Off
	Ignition switch ON	On
KEY ON SW	Mechanical key is removed from key cylinder	Off
	Mechanical key is inserted to key cylinder	On
CDL LOCK SW	Door lock/unlock switch does not operate	Off
	Press door lock/unlock switch to the lock side	On
CDL UNLOCK SW	Door lock/unlock switch does not operate	Off
	Press door lock/unlock switch to the unlock side	On
DOOR SW-DR	Driver's door closed	Off
	Driver's door opened	On
DOOR SW-AS	Passenger door closed	Off
	Passenger door opened	On
DOOR SW-RR	Rear RH door closed	Off
	Rear RH door opened	On
DOOR SW-RL	Rear LH door closed	Off
	Rear LH door opened	On
BACK DOOR SW	Back door closed	Off
	Back door opened	On
LOCK STATUS	<b>NOTE:</b> The item is indicated, but not monitored.	Off
ACC ON SW	Ignition switch OFF	Off
	Ignition switch ACC or ON	On
KEYLESS LOCK	"LOCK" button of key fob is not pressed	Off
	"LOCK" button of key fob is pressed	On
KEYLESS UNLOCK	"UNLOCK" button of key fob is not pressed	Off
	"UNLOCK" button of key fob is pressed	On
SHOCK SENSOR	<b>NOTE:</b> The item is indicated, but not monitored.	NORMAL
KEY CYL LK-SW	Other than driver door key cylinder LOCK position	Off
	Driver door key cylinder LOCK position	On
KEY CYL UN-SW	Other than driver door key cylinder UNLOCK position	Off
	Driver door key cylinder UNLOCK position	On
VEHICLE SPEED	While driving	Equivalent to speedometer reading
REAR DEF SW	Rear window defogger switch OFF	Off
	Rear window defogger switch ON	On
REVERSE SW CAN	<b>NOTE:</b> The item is indicated, but not used.	Off
		On

# BCM (BODY CONTROL MODULE)

< ECU DIAGNOSIS INFORMATION >

[MANUAL AIR CONDITIONING]

Monitor Item	Condition	Value/Status	
TAIL LAMP SW	Lighting switch OFF	Off	A
	Lighting switch 1ST	On	
FR FOG SW	Front fog lamp switch OFF	Off	B
	Front fog lamp switch ON	On	
BUCKLE SW	The seat belt (driver side) is fastened. [Seat belt switch (driver side) OFF]	Off	C
	The seat belt (driver side) is unfastened. [Seat belt switch (driver side) ON]	On	
TRNK/HAT MNTR	<b>NOTE:</b> The item is indicated, but not monitored.	Off	D
ACC SW	Ignition switch OFF	Off	E
	Ignition switch ACC or ON	On	
KYLS TRNK/HAT	<b>NOTE:</b> The item is indicated, but not monitored.	Off	F
KEYLESS PANIC	PANIC button of key fob is not pressed	Off	G
	PANIC button of key fob is pressed	On	
HI BEAM SW	Lighting switch OFF	Off	H
	Lighting switch HI	On	
HEAD LAMP SW 1	Lighting switch OFF	Off	I
	Lighting switch 2ND	On	
HEAD LAMP SW 2	Lighting switch OFF	Off	J
	Lighting switch 2ND	On	
AUTO LIGHT SW	Lighting switch OFF	Off	K
	Lighting switch AUTO	On	
PASSING SW	Other than lighting switch PASS	Off	L
	Lighting switch PASS	On	
RR FOG SW	<b>NOTE:</b> The item is indicated, but not monitored.	Off	M
TURN SIGNAL R	Turn signal switch OFF	Off	N
	Turn signal switch RH	On	
TURN SIGNAL L	Turn signal switch OFF	Off	O
	Turn signal switch LH	On	
PKB SW	Parking brake switch is OFF	Off	P
	Parking brake switch is ON	On	
ENGINE RUN	Engine stopped	Off	
	Engine running	On	
OPTI SEN (DTCT)	Bright outside of the vehicle	Close to 5 V	
	Dark outside of the vehicle	Close to 0 V	
OPTI SEN (FILT)	Bright outside of the vehicle (Lighting switch AUTO)	Close to 5 V	
	Dark outside of the vehicle (Lighting switch AUTO)	Close to 1.50 V	
LIG SEN COND	<b>NOTE:</b> The item is indicated, but not monitored.	OFF	
IGN SW CAN	Ignition switch OFF or ACC	Off	
	Ignition switch ON	On	
FR WIPER HI	Front wiper switch OFF	Off	
	Front wiper switch HI	On	
FR WIPER LOW	Front wiper switch OFF	Off	
	Front wiper switch LO	On	

A  
B  
C  
D  
E  
F  
G  
H  
I  
J  
K  
L  
M  
N  
O  
P

HAC

# BCM (BODY CONTROL MODULE)

< ECU DIAGNOSIS INFORMATION >

[MANUAL AIR CONDITIONING]

Monitor Item	Condition	Value/Status
FR WIPER INT	Front wiper switch OFF	Off
	Front wiper switch INT	On
FR WASHER SW	Front washer switch OFF	Off
	Front washer switch ON	On
INT VOLUME	Wiper intermittent dial is in a dial position 1 - 7	1 - 7
FR WIPER STOP	Any position other than front wiper stop position	Off
	Front wiper stop position	On
RR WIPER ON	Rear wiper switch OFF	Off
	Rear wiper switch ON	On
RR WIPER INT	Rear wiper switch OFF	Off
	Rear wiper switch INT	On
RR WASHER SW	Rear washer switch OFF	Off
	Rear washer switch ON	On
RR WIPER STOP	Rear wiper stop position	Off
	Other than rear wiper stop position	On
RAIN SENSOR	<b>NOTE:</b> The item is indicated, but not monitored.	Off
HAZARD SW	Hazard switch OFF	Off
	Hazard switch ON	On
FAN ON SIG	Blower control dial OFF	Off
	Other than blower control dial OFF	On
AIR COND SW	<ul style="list-style-type: none"> <li>• Air conditioner OFF (A/C switch indicator OFF) (Automatic air conditioner)</li> <li>• A/C switch OFF (Manual air conditioner)</li> </ul>	Off
	<ul style="list-style-type: none"> <li>• Air conditioner ON (A/C switch indicator ON) (Automatic air conditioner)</li> <li>• A/C switch ON (Manual air conditioner)</li> </ul>	On
THERMO AMP <b>NOTE:</b> At models with automatic air conditioner this item is not monitored.	Ignition switch ON	Off
	Evaporator is extremely low temperature	On
FR DEF SW	Other than A/C mode defroster ON position	Off
	A/C mode defroster ON position	On
KEYLESS TRUNK	<b>NOTE:</b> The item is indicated, but not monitored.	Off
TRNK OPNR SW	<b>NOTE:</b> The item is indicated, but not monitored.	Off
TRNK OPN MNTR	<b>NOTE:</b> The item is indicated, but not monitored.	Off
HOOD SW	Close the hood	Off
	Open the hood	On
TRANSPONDER	Other than the ignition switch is ON by key registered to BCM.	Off
	The ignition switch is ON by key registered to BCM.	On
INTELLI KEY	<b>NOTE:</b> The item is indicated, but not used.	Off
AUTO RELOCK	<b>NOTE:</b> The item is indicated, but not monitored.	Off

# BCM (BODY CONTROL MODULE)

< ECU DIAGNOSIS INFORMATION >

[MANUAL AIR CONDITIONING]

Monitor Item	Condition	Value/Status
OIL PRESS SW	<ul style="list-style-type: none"> <li>Ignition switch OFF or ACC</li> <li>Engine running</li> </ul>	Off
	Ignition switch ON	On
BRAKE SW	Brake pedal is not depressed	Off
	Brake pedal is depressed	On

## TERMINAL LAYOUT

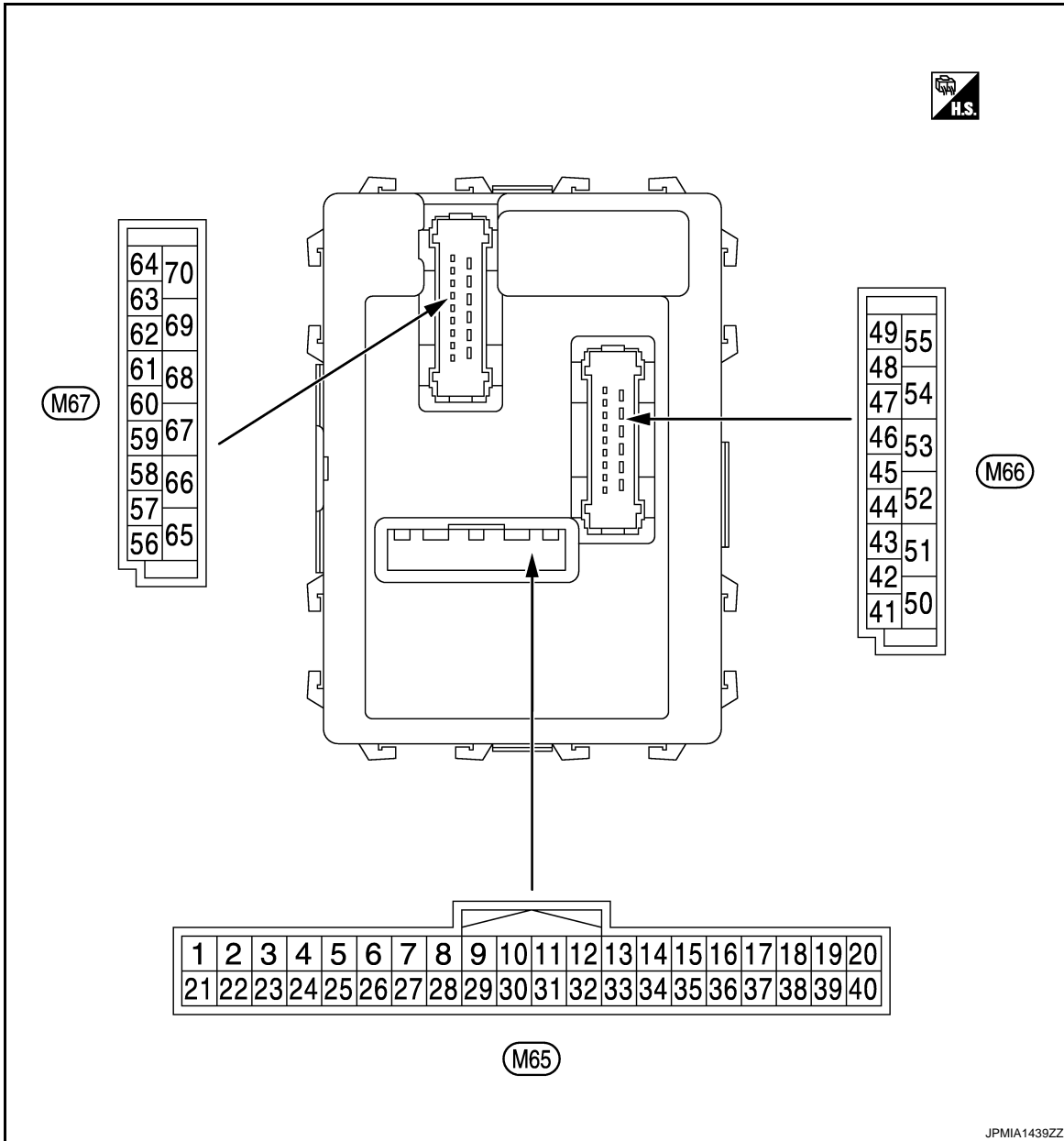

**NOTE:**

- M65, M66: White
- M67: Black

## PHYSICAL VALUES

A  
B  
C  
D  
E  
F  
G  
H  
HAC  
J  
K  
L  
M  
N  
O  
P

# BCM (BODY CONTROL MODULE)

< ECU DIAGNOSIS INFORMATION >

[MANUAL AIR CONDITIONING]

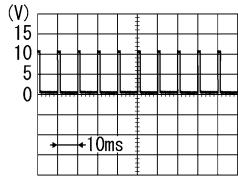
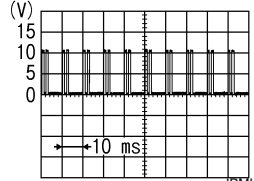
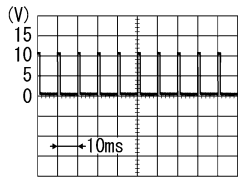
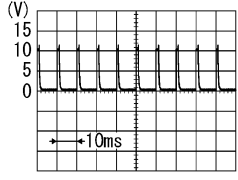
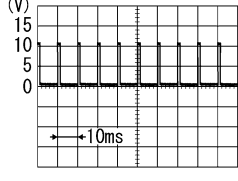
Terminal No. (Wire color)		Description		Condition	Value (Approx.)
+	-	Signal name	Input/ Output		
2 (BR/W)	Ground	Combination switch INPUT 5	Input	All switch OFF	0 V
				Turn signal switch RH	 <p style="text-align: right; font-size: small;">PKIB4958J</p>
				Lighting switch HI	
				Lighting switch 1ST	
				Lighting switch 2ND	 <p style="text-align: right; font-size: small;">JPMIA0342JP</p>
3 (GR)	Ground	Combination switch INPUT 4	Input	All switch OFF	0 V
				Turn signal switch LH	 <p style="text-align: right; font-size: small;">PKIB4958J</p>
				Lighting switch PASS	
				Lighting switch 2ND	
				Front fog lamp switch ON	 <p style="text-align: right; font-size: small;">PKIB4956J</p>
4 (L/Y)	Ground	Combination switch INPUT 3	Input	All switch OFF	0 V
				Front wiper switch LO	 <p style="text-align: right; font-size: small;">PKIB4958J</p>
				Front wiper switch MIST	
				Front wiper switch INT	
				Lighting switch AUTO	

# BCM (BODY CONTROL MODULE)

< ECU DIAGNOSIS INFORMATION >

[MANUAL AIR CONDITIONING]

Terminal No. (Wire color)		Description		Condition	Value (Approx.)		
+	-	Signal name	Input/ Output				
5 (G)	Ground	Combination switch INPUT 2	Input	Combination switch	All switch OFF (Wiper intermittent dial 4)	0 V	
					Front washer switch (Wiper intermittent dial 4)		
					Rear washer switch ON (Wiper intermittent dial 4)		
					Any of the condition below with all switch OFF <ul style="list-style-type: none"> <li>• Wiper intermittent dial 1</li> <li>• Wiper intermittent dial 5</li> <li>• Wiper intermittent dial 6</li> </ul>		1.0 V
					Rear wiper switch ON (Wiper intermittent dial 4)		0.8 V
6 (L/R)	Ground	Combination switch INPUT 1	Input	Combination switch	All switch OFF (Wiper intermittent dial 4)	0 V	
					Front wiper switch HI (Wiper intermittent dial 4)		
					Rear wiper switch INT (Wiper intermittent dial 4)		
					Wiper intermittent dial 3 (All switch OFF)		1.0 V
					Any of the condition below with all switch OFF <ul style="list-style-type: none"> <li>• Wiper intermittent dial 1</li> <li>• Wiper intermittent dial 2</li> </ul>		1.9 V
					Any of the condition below with all switch OFF <ul style="list-style-type: none"> <li>• Wiper intermittent dial 6</li> <li>• Wiper intermittent dial 7</li> </ul>		0.8 V

A  
B  
C  
D  
E  
F  
G  
H  
HAC  
J  
K  
L  
M  
N  
O  
P

# BCM (BODY CONTROL MODULE)

< ECU DIAGNOSIS INFORMATION >

[MANUAL AIR CONDITIONING]

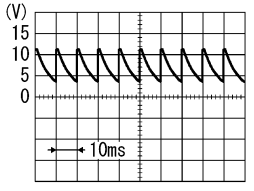
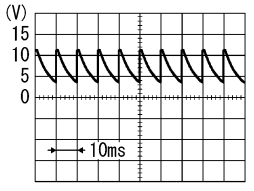
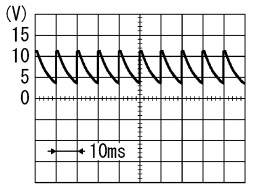
Terminal No. (Wire color)		Description		Condition	Value (Approx.)	
+	-	Signal name	Input/ Output			
7 (W/R)	Ground	Door key cylinder switch UNLOCK	Input	Door key cylinder switch	NEUTRAL position	 7.0 - 8.0 V
				UNLOCK position	0 V	
8 (W/B)	Ground	Door key cylinder switch LOCK	Input	Door key cylinder switch	NEUTRAL position	12 V
				LOCK position	0 V	
9 (R)	Ground	Stop lamp switch	Input	Stop lamp switch	OFF (Brake pedal is not depressed)	0 V
				ON (Brake pedal is de- pressed)	Battery voltage	
10 (W/L)	Ground	Rear window defog- ger switch	Input	Rear window defogger switch	OFF (Not pressed)	12 V
				ON (Pressed)	0 V	
11 (L/Y)	Ground	Ignition switch ACC	Input	Ignition switch OFF	0 V	
				Ignition switch ACC or ON	Battery voltage	
12 (SB)	Ground	Passenger door switch	Input	Passenger door switch	OFF (When passenger door closed)	 7.0 - 8.0 V
				ON (When passenger door opened)	0 V	
13 (GR/L)	Ground	Rear RH door switch	Input	Rear RH door switch	OFF (When rear RH door closed)	 7.0 - 8.0 V
				ON (When rear RH door opened)	0 V	
14 (L/B)	Ground	Optical sensor	Input	Ignition switch ON	When bright outside of the vehicle	Close to 5 V
				When dark outside of the vehicle	Close to 0 V	



# BCM (BODY CONTROL MODULE)

< ECU DIAGNOSIS INFORMATION >

[MANUAL AIR CONDITIONING]

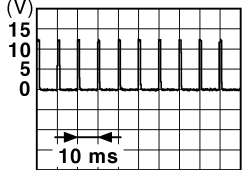
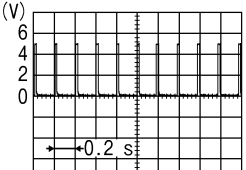
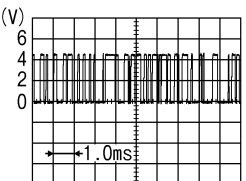
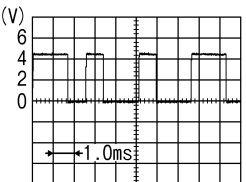
Terminal No. (Wire color)		Description		Condition		Value (Approx.)
+	-	Signal name	Input/ Output			
15 (V/W)	Ground	Tire pressure warning check switch	Input	Ignition switch OFF		 <small>JPMIA0012GB</small> 1.0 - 1.5 V
17 (R/G)	Ground	Optical sensor power supply	Output	Ignition switch	OFF, ACC	0 V
					ON	5 V
18 (V)	Ground	Receiver and sensor ground	Input	Ignition switch ON		0 V
19 (BR)	Ground	Remote keyless entry receiver power supply	Input	Ignition switch OFF	Insert mechanical key into ignition key cylinder	0 V
					Remove mechanical key from ignition key cylinder (Any door opened)	5 V
					Remove mechanical key from ignition key cylinder (Any door closed)	 <small>JPMIA0338JP</small>
20 (G/Y)	Ground	Remote keyless entry receiver communication	Input	Ignition switch OFF	Insert mechanical key into ignition key cylinder	0 V
					Waiting	 <small>PIIB7728J</small>
					Signal receiving	 <small>PIIB7729J</small>
21 (P/L)	Ground	Immobilizer antenna (Clock)	Input/ Output	During waiting	Ignition switch is pressed while inserting the key into the key slot.	Just after pressing ignition switch. Pointer of tester should move.

A  
B  
C  
D  
E  
F  
G  
H  
J  
K  
L  
M  
N  
O  
P

HAC

# BCM (BODY CONTROL MODULE)

< ECU DIAGNOSIS INFORMATION >

[MANUAL AIR CONDITIONING]

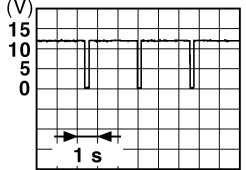
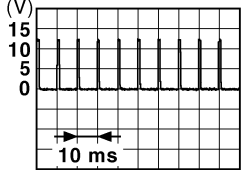
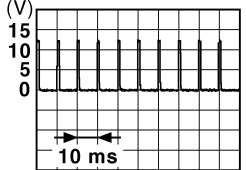
Terminal No. (Wire color)		Description		Condition		Value (Approx.)
+	-	Signal name	Input/ Output			
23 (R/Y)	Ground	Security indicator	Input	Security indicator	ON	0 V
					Blinking (Ignition switch OFF)	 <p style="text-align: right; font-size: small;">JPMIA0014GB</p>
					OFF	12 V
24 (GR/R)	Ground	Dongle link	Input/ Output	Ignition switch OFF		5 V
25 (LG)	Ground	Immobilizer antenna (Rx, Tx)	Input/ Output	During waiting	Ignition switch is pressed while inserting the key into the key slot.	Just after pressing ignition switch. Pointer of tester should move.
26*1 (GR)	Ground	Thermo control amp.	Input	Ignition switch ON		0 V
				Evaporator is extremely low temperature		12 V
27 (Y/G)*2 (Y/R)*3	Ground	A/C switch (Automatic air conditioner)	Input	A/C	OFF (A/C switch indicator: OFF)	 <p style="text-align: right; font-size: small;">JPMIA0012GB</p>
					ON (A/C switch indicator: ON)	0 V
		A/C switch (Manual air conditioner)		A/C switch	OFF	 <p style="text-align: right; font-size: small;">JPMIA0012GB</p>
					ON	0 V

# BCM (BODY CONTROL MODULE)

< ECU DIAGNOSIS INFORMATION >

[MANUAL AIR CONDITIONING]

Terminal No. (Wire color)		Description		Condition	Value (Approx.)
+	-	Signal name	Input/ Output		
28 (G/W)	Ground	Blower fan switch (Automatic air conditioner)	Input	Fan switch	Blower fan switch OFF 0 V
				Fan switch	Blower fan switch ON  7.0 - 8.0 V
		Blower fan switch (Manual air conditioner)	Fan switch	Fan switch	Blower fan switch OFF  7.0 - 8.0 V
				Fan switch	Blower fan switch ON 0 V
29 (L/W)	Ground	Hazard switch	Input	Hazard switch	OFF Battery voltage
				Hazard switch	ON 0 V
31 (G/Y)	Ground	Front defroster switch	Input	Ignition switch ON	A/C mode defroster ON position 0 V
				Ignition switch ON	Other than A/C mode defroster ON position  8.0 - 9.0 V
32 (LG)	Ground	Combination switch OUTPUT 5	Output	Combination switch	All switch OFF (Wiper intermittent dial 4)  7.0 - 8.0 V
				Combination switch	Front fog lamp switch ON (Wiper intermittent dial 4)
				Combination switch	Rear wiper switch ON (Wiper intermittent dial 4)
				Combination switch	Any of the condition below with all switch OFF <ul style="list-style-type: none"> <li>Wiper intermittent dial 1</li> <li>Wiper intermittent dial 2</li> <li>Wiper intermittent dial 6</li> <li>Wiper intermittent dial 7</li> </ul> 1.0 V

A  
B  
C  
D  
E  
F  
G  
H  
HAC  
J  
K  
L  
M  
N  
O  
P

# BCM (BODY CONTROL MODULE)

< ECU DIAGNOSIS INFORMATION >

[MANUAL AIR CONDITIONING]

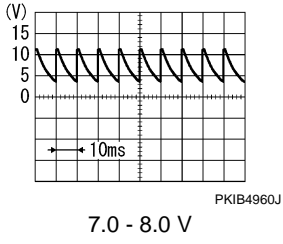
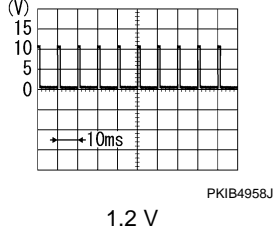
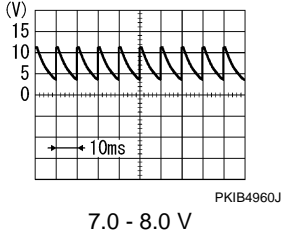
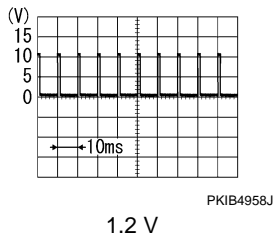
Terminal No. (Wire color)		Description		Condition	Value (Approx.)	
+	-	Signal name	Input/ Output			
33 (Y/L)	Ground	Combination switch OUTPUT 4	Output	Combination switch	All switch OFF (Wiper intermittent dial 4)	 <p style="text-align: center;">7.0 - 8.0 V</p>
					Lighting switch 1ST (Wiper intermittent dial 4)	 <p style="text-align: center;">1.2 V</p>
					Lighting switch AUTO (Wiper intermittent dial 4)	
					Rear wiper switch INT (Wiper intermittent dial 4)	
Any of the condition below with all switch OFF						
<ul style="list-style-type: none"> <li>• Wiper intermittent dial 1</li> <li>• Wiper intermittent dial 5</li> <li>• Wiper intermittent dial 6</li> </ul>						
34 (W)	Ground	Combination switch OUTPUT 3	Output	Combination switch	All switch OFF (Wiper intermittent dial 4)	 <p style="text-align: center;">7.0 - 8.0 V</p>
					Lighting switch 2ND (Wiper intermittent dial 4)	 <p style="text-align: center;">1.2 V</p>
					Lighting switch HI (Wiper intermittent dial 4)	
					Rear washer switch ON (Wiper intermittent dial 4)	
Any of the condition below with all switch OFF						
<ul style="list-style-type: none"> <li>• Wiper intermittent dial 1</li> <li>• Wiper intermittent dial 2</li> <li>• Wiper intermittent dial 3</li> </ul>						

# BCM (BODY CONTROL MODULE)

< ECU DIAGNOSIS INFORMATION >

[MANUAL AIR CONDITIONING]

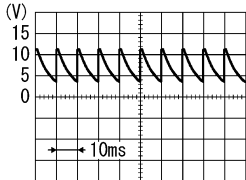
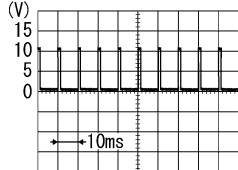
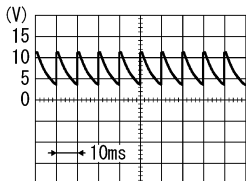
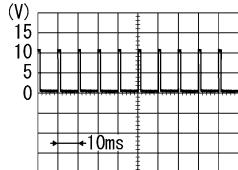
Terminal No. (Wire color)		Description		Condition	Value (Approx.)	
+	-	Signal name	Input/ Output			
35 (R/L)	Ground	Combination switch OUTPUT 2	Output	Combination switch (Wiper intermit- tent dial 4)	All switch OFF	 <p style="text-align: center;">7.0 - 8.0 V</p>
					Lighting switch 2ND	 <p style="text-align: center;">1.2 V</p>
					Lighting switch PASS	
					Front wiper switch INT	
Front wiper switch HI					1.2 V	
36 (L/O)	Ground	Combination switch OUTPUT 1	Output	Combination switch (Wiper intermit- tent dial 4)	All switch OFF	 <p style="text-align: center;">7.0 - 8.0 V</p>
					Turn signal switch RH	 <p style="text-align: center;">1.2 V</p>
					Turn signal switch LH	
					Front wiper switch LO (Front wiper switch MIST)	
Front washer switch ON					1.2 V	
37 (R/W)	Ground	Key switch	Input	Insert mechanical key into ignition key cylinder	Battery voltage	
				Remove mechanical key from ignition key cylinder	0 V	
38 (O)	Ground	Ignition switch ON	Input	Ignition switch OFF or ACC	0 V	
				Ignition switch ON	Battery voltage	
39 (L)	Ground	CAN-H	Input/ Output	—	—	
40 (P)	Ground	CAN-L	Input/ Output	—	—	

A  
B  
C  
D  
E  
F  
G  
H  
HAC  
J  
K  
L  
M  
N  
O  
P

# BCM (BODY CONTROL MODULE)

< ECU DIAGNOSIS INFORMATION >

[MANUAL AIR CONDITIONING]

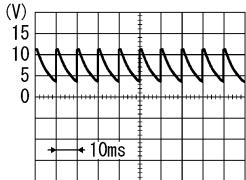
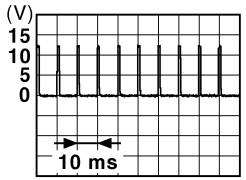
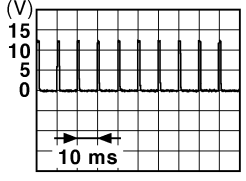
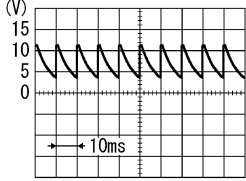
Terminal No. (Wire color)		Description		Condition	Value (Approx.)	
+	-	Signal name	Input/ Output			
43 (W)	Ground	Back door switch	Input	Back door switch	OFF (When back door closed)	 <p style="text-align: right; font-size: small;">PKIB4960J</p> <p style="text-align: center;">7.0 - 8.0 V</p>
					ON (When back door opened)	0 V
44 (LG)	Ground	Rear wiper stop position	Input	Ignition switch ON	Rear wiper stop position	12 V
					Any position other than rear wiper stop position	0 V
45 (GR)	Ground	Door lock and unlock switch LOCK	Input	Door lock and unlock switch	NEUTRAL position	 <p style="text-align: right; font-size: small;">JPMIA0012GB</p> <p style="text-align: center;">1.0 - 1.5 V</p>
					LOCK position	0 V
46 (BR)	Ground	Door lock and unlock switch UNLOCK	Input	Door lock and unlock switch	NEUTRAL position	 <p style="text-align: right; font-size: small;">JPMIA0012GB</p> <p style="text-align: center;">1.0 - 1.5 V</p>
					UNLOCK position	0 V
47 (BR/Y)	Ground	Driver door switch	Input	Driver door switch	OFF (When driver door closed)	 <p style="text-align: right; font-size: small;">PKIB4960J</p> <p style="text-align: center;">7.0 - 8.0 V</p>
					ON (When driver door opened)	0 V

# BCM (BODY CONTROL MODULE)

< ECU DIAGNOSIS INFORMATION >

[MANUAL AIR CONDITIONING]

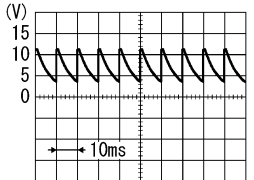
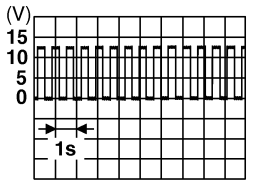
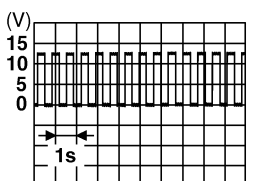
Terminal No. (Wire color)		Description		Condition	Value (Approx.)	
+	-	Signal name	Input/ Output			
48 (W/G)	Ground	Rear LH door switch	Input	Rear LH door switch	OFF (When rear LH door closed)	 <small>PKIB4960J</small> 7.0 - 8.0 V
				Rear LH door switch	ON (When rear LH door opened)	0 V
50*1 (SB)	Ground	A/C indicator	Output	A/C indicator	OFF	12 V
				A/C indicator	ON	0 V
54 (L/W)	Ground	Rear wiper	Output	Ignition switch ON	Rear wiper switch OFF	0 V
				Ignition switch ON	Rear wiper switch ON	12 V
56 (L)	Ground	Interior room lamp power supply	Output	Interior room lamp battery saver is activated. (Cuts the interior room lamp power supply)	0 V	
				Interior room lamp battery saver is not activated. (Outputs the interior room lamp power supply)	12 V	
57 (Y)	Ground	Battery power supply	Input	Ignition switch OFF	Battery voltage	
59 (L/B)	Ground	Driver door UNLOCK	Output	Driver door	UNLOCK (Actuator is activated)	12 V
				Driver door	Other than UNLOCK (Actuator is not activated)	0 V
60 (W/B)	Ground	Turn signal LH	Output	Ignition switch ON	Turn signal switch OFF	0 V
				Ignition switch ON	Turn signal switch LH	 <small>PKIC6370E</small> 6.0 V
61 (W/L)	Ground	Turn signal RH	Output	Ignition switch ON	Turn signal switch OFF	0 V
				Ignition switch ON	Turn signal switch RH	 <small>PKIC6370E</small> 6.0 V
63 (BR)	Ground	Interior room lamp timer control	Output	Interior room lamp	OFF	12 V
				Interior room lamp	ON	0 V

A  
B  
C  
D  
E  
F  
G  
H  
HAC  
J  
K  
L  
M  
N  
O  
P

# BCM (BODY CONTROL MODULE)

< ECU DIAGNOSIS INFORMATION >

[MANUAL AIR CONDITIONING]

Terminal No. (Wire color)		Description		Condition		Value (Approx.)
+	-	Signal name	Input/ Output			
65 (V)	Ground	All doors LOCK	Output	All doors	LOCK (Actuator is activated)	12 V
					Other then LOCK (Actuator is not activated)	0 V
66 (G)	Ground	Passenger door and rear door UNLOCK	Output	Passenger door and rear door	UNLOCK (Actuator is activated)	12 V
					Other then UNLOCK (Actuator is not activated)	0 V
67 (B)	Ground	Ground	Output	Ignition switch ON		0 V
68 (L)	Ground	P/W power supply (IGN)	Output	Ignition switch ON		12 V
69 (L/W)	Ground	P/W power supply (BAT)	Output	Ignition switch OFF		12 V
70 (Y)	Ground	Battery power supply	Input	Ignition switch OFF		Battery voltage

- \*1: Only manual air conditioner
- \*2: Automatic air conditioner
- \*3: Manual air conditioner



# BCM (BODY CONTROL MODULE)

< ECU DIAGNOSIS INFORMATION >

[MANUAL AIR CONDITIONING]

## Wiring Diagram - BCM -

INFOID:000000005819865

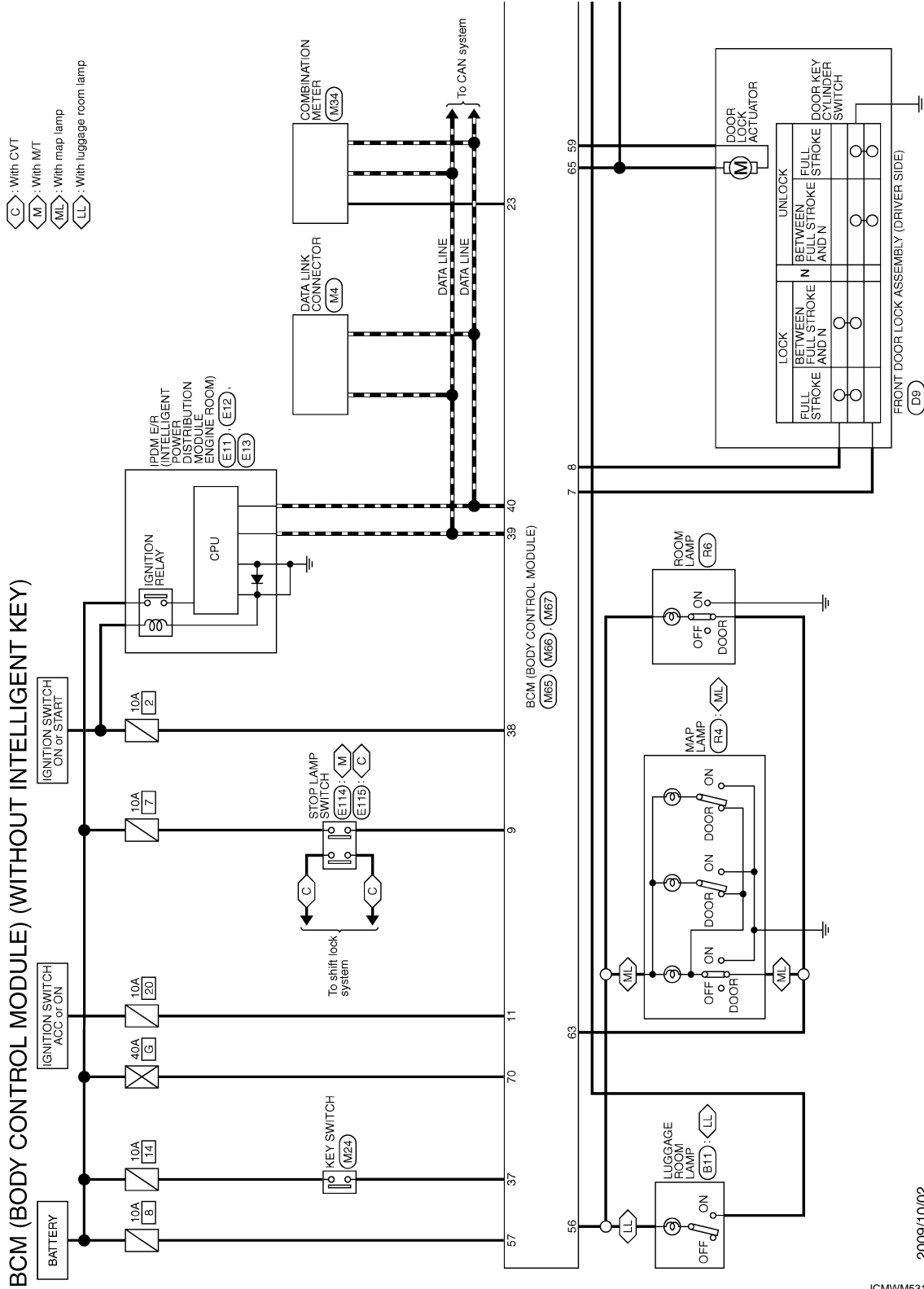

2009/10/02

JCMWM5310G1

A  
B  
C  
D  
E  
F  
G  
H  
HAC  
J  
K  
L  
M  
N  
O  
P

# BCM (BODY CONTROL MODULE)

< ECU DIAGNOSIS INFORMATION >

[MANUAL AIR CONDITIONING]

AA: With auto A/C  
 MA: With manual A/C  
 AL: With auto light system

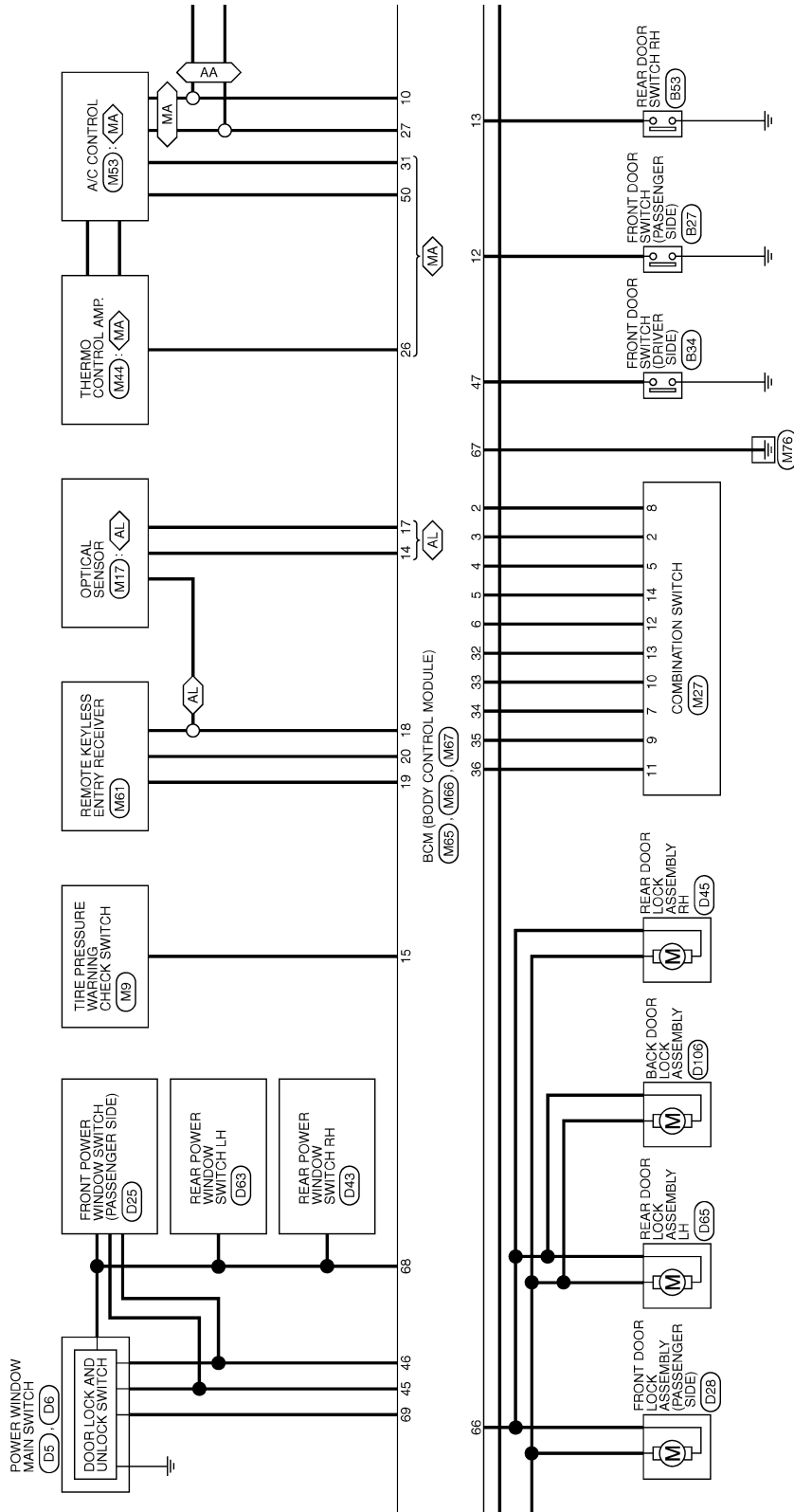

JCMWM5311GI

# BCM (BODY CONTROL MODULE)

< ECU DIAGNOSIS INFORMATION >

[MANUAL AIR CONDITIONING]

- : For Canada
- : With auto A/C
- : With manual A/C
- : With luggage room lamp

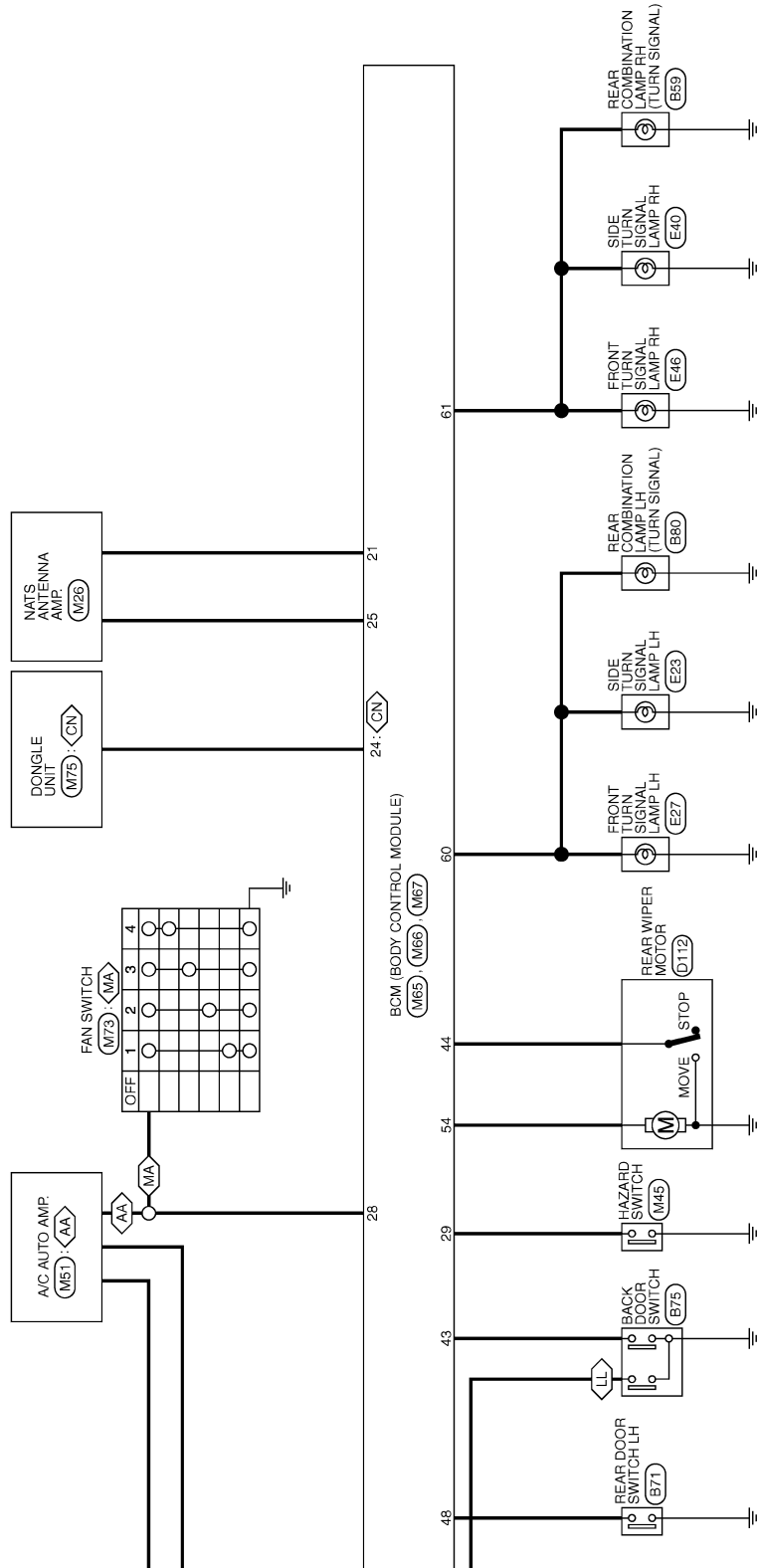

JCMWM5312GI

A  
B  
C  
D  
E  
F  
G  
H  
**HAC**  
J  
K  
L  
M  
N  
O  
P

# BCM (BODY CONTROL MODULE)

< ECU DIAGNOSIS INFORMATION >

[MANUAL AIR CONDITIONING]

## BCM (BODY CONTROL MODULE) (WITHOUT INTELLIGENT KEY)

Connector No.	M27
Connector Name	COMBINATION SWITCH
Connector Type	TH16PW-NH

1	2	3	4	5	6
7	8	9	10	11	12
13	14				



Terminal No.	Color of Wire	Signal Name [Specification]
1	O	WASHER (RR)
2	GR	INPUT 4
3	L	WASHER (FR)
4	W	IGN
5	L/Y	INPUT 3
6	B	GND
7	W	OUTPUT 3
8	BR/W	INPUT 5
9	R/L	OUTPUT 2
10	Y/L	OUTPUT 4
11	L/O	OUTPUT 1
12	L/R	INPUT 1
13	LG	OUTPUT 5
14	G	INPUT 2

Connector No.	M65
Connector Name	BCM (BODY CONTROL MODULE)
Connector Type	TH40PW-NH



1	2	3	4	5	6	7	8	9	10	11	12	13	14	15	16	17	18	19	20
21	22	23	24	25	26	27	28	29	30	31	32	33	34	35	36	37	38	39	40

Terminal No.	Color of Wire	Signal Name [Specification]
2	BR/W	COMBI SW INPUT 5
3	GR	COMBI SW INPUT 4
4	L/Y	COMBI SW INPUT 3
5	G	COMBI SW INPUT 2
6	L/R	COMBI SW INPUT 1
7	W/R	KEY CYL UNLOCK SW
8	W/B	KEY CYL LOCK SW
9	R	STOP LAMP SW

Terminal No.	Color of Wire	Signal Name [Specification]
10	W/L	REAR WINDOW DEFROGGER SW
11	L/Y	ACC.
12	SR	PASSENGER DOOR SW
13	SR	REAR RH DOOR SW
14	L/B	OPTICAL SENSOR
15	V/W	TIRE PRESS WARNING CHECK SW
17	R/G	OPTICAL SENSOR POWER SUPPLY
18	V	RECEIVER/SENSOR GND
19	BR	KEYLESS ENTRY RECEIVER POWER SUPPLY
20	G/Y	KEYLESS ENTRY RECEIVER COMM
21	P/L	NATS ANTENNA AMP
23	R/Y	SECURITY INDICATOR LAMP
24	GR/R	DONGLE LINK
25	LG	NATS ANTENNA AMP
26	GR	THERMO CONTROL AMP
27	Y/G	A/C SW [With auto A/C]
27	Y/R	A/C SW [With manual A/C]
28	G/W	BLOWER FAN SW
29	L/W	HAZARD SW
31	G/Y	FR DEFROSTER SW
32	LG	COMBI SW OUTPUT 5
33	Y/L	COMBI SW OUTPUT 4
34	W	COMBI SW OUTPUT 3
35	R/L	COMBI SW OUTPUT 2
36	L/O	COMBI SW OUTPUT 1
37	R/W	KEY SWITCH
38	O	IGN
39	L	CAN-H
40	P	CAN-L

Connector No.	M65
Connector Name	BCM (BODY CONTROL MODULE)
Connector Type	FEA09FW-FH46-SA



41	42	43	44	45	46	47	48	49
50	51	52	53	54	55			

Terminal No.	Color of Wire	Signal Name [Specification]
43	W	BACK DOOR SW
44	LG	REAR WIPER STOP POSITION
45	GR	CENTRAL DOOR LOCK SW
46	BR	CENTRAL DOOR UNLOCK SW
47	BR/Y	DRIVER DOOR SW
48	W/G	REAR LH DOOR SW
50	SB	A/C INDICATOR OUTPUT

54	L/W	REAR WIPER OUTPUT
----	-----	-------------------

Connector No.	M67
Connector Name	BCM (BODY CONTROL MODULE)
Connector Type	FEA09FB-FH46-SA



56	57	58	59	60	61	62	63	64
65	66	67	68	69	70			

Terminal No.	Color of Wire	Signal Name [Specification]
56	L	INTERIOR ROOM LAMP POWER SUPPLY
57	Y	BAT.(FUSE)
59	L/B	DRIVER DOOR UNLOCK OUTPUT
60	W/B	TURN SIGNAL LH OUTPUT
61	W/L	TURN SIGNAL RH OUTPUT
63	BR	ROOM LAMP-TIMER CONTROL
65	V	ALL DOOR LOCK OUTPUT
66	G	PASSENGER DOOR REAR DOOR UNLOCK OUTPUT
67	B	GND
68	L	POWER WINDOW POWER SUPPLY (IGN)
69	L/W	POWER WINDOW POWER SUPPLY (BAT)
70	Y	BAT.(F/L)

## Fail-safe

### FAIL-SAFE CONTROL BY DTC

BCM performs fail-safe control when any DTC are detected.

JCMW5313G

INFOID:000000005819866

# BCM (BODY CONTROL MODULE)

< ECU DIAGNOSIS INFORMATION >

[MANUAL AIR CONDITIONING]

Display contents of CONSULT	Fail-safe	Cancellation
B2190: NATS ANTENNA AMP	Inhibit engine cranking	Erase DTC
B2191: DIFFERENCE OF KEY	Inhibit engine cranking	Erase DTC
B2192: ID DISCORD BCM-ECM	Inhibit engine cranking	Erase DTC
B2193: CHAIN OF BCM-ECM	Inhibit engine cranking	Erase DTC
B2195: ANTI SCANNING	Inhibit engine cranking	Ignition switch ON → OFF
B2196: DONGLE NG	Inhibit engine cranking	Erase DTC

## REAR WIPER MOTOR PROTECTION

BCM detects the rear wiper stopping position according to the rear wiper auto stop signal.

When the rear wiper auto stop signal does not change more than 5 seconds while driving the rear wiper, BCM stops power supply to protect the rear wiper motor.

Condition of cancellation

1. Pass more than 1 minute after the rear wiper stop.
2. Turn rear wiper switch OFF.
3. Operate the rear wiper switch or rear washer switch.

## DTC Inspection Priority Chart

INFOID:000000005819867

If some DTCs are displayed at the same time, perform inspections one by one based on the following priority chart.

Priority	DTC
1	<ul style="list-style-type: none"> <li>• U1000: CAN COMM</li> <li>• U1010: CONTROL UNIT (CAN)</li> </ul>
2	<ul style="list-style-type: none"> <li>• B2190: NATS ANTENNA AMP</li> <li>• B2191: DIFFERENCE OF KEY</li> <li>• B2192: ID DISCORD BCM-ECM</li> <li>• B2193: CHAIN OF BCM-ECM</li> <li>• B2195: ANTI SCANNING</li> <li>• B2196: DONGLE NG</li> </ul>
3	C1735: IGN CIRCUIT OPEN
4	<ul style="list-style-type: none"> <li>• C1704: LOW PRESSURE FL</li> <li>• C1705: LOW PRESSURE FR</li> <li>• C1706: LOW PRESSURE RR</li> <li>• C1707: LOW PRESSURE RL</li> <li>• C1708: [NO DATA] FL</li> <li>• C1709: [NO DATA] FR</li> <li>• C1710: [NO DATA] RR</li> <li>• C1711: [NO DATA] RL</li> <li>• C1716: [PRESSDATA ERR] FL</li> <li>• C1717: [PRESSDATA ERR] FR</li> <li>• C1718: [PRESSDATA ERR] RR</li> <li>• C1719: [PRESSDATA ERR] RL</li> <li>• C1729: VHCL SPEED SIG ERR</li> <li>• C1734: CONTROL UNIT</li> </ul>

## DTC Index

INFOID:000000005819868

### NOTE:

Details of time display

- CRNT: Displays when there is a malfunction now or after returning to the normal condition until turning ignition switch OFF → ON again.
- 1 - 39: Displayed if any previous malfunction is present when current condition is normal. It increases like 1 → 2 → 3...38 → 39 after returning to the normal condition whenever ignition switch OFF → ON. The counter remains at 39 even if the number of cycles exceeds it. It is counted from 1 again when turning ignition switch OFF → ON after returning to the normal condition if the malfunction is detected again.

# BCM (BODY CONTROL MODULE)

< ECU DIAGNOSIS INFORMATION >

[MANUAL AIR CONDITIONING]

CONSULT display	Fail-safe	Tire pressure monitor warn- ing lamp ON	Reference
U1000: CAN COMM	—	—	<a href="#">BCS-115</a>
U1010: CONTROL UNIT (CAN)	—	—	<a href="#">BCS-116</a>
B2190: NATS ANTENNA AMP	×	—	<a href="#">SEC-219</a>
B2191: DIFFERENCE OF KEY	×	—	<a href="#">SEC-222</a>
B2192: ID DISCORD BCM-ECM	×	—	<a href="#">SEC-223</a>
B2193: CHAIN OF BCM-ECM	×	—	<a href="#">SEC-225</a>
B2195: ANTI SCANNING	×	—	<a href="#">SEC-226</a>
B2196: DONGLE NG	×	—	<a href="#">SEC-227</a>
C1704: LOW PRESSURE FL	—	×	<a href="#">WT-30</a>
C1705: LOW PRESSURE FR	—	×	
C1706: LOW PRESSURE RR	—	×	
C1707: LOW PRESSURE RL	—	×	
C1708: [NO DATA] FL	—	×	<a href="#">WT-32</a>
C1709: [NO DATA] FR	—	×	
C1710: [NO DATA] RR	—	×	
C1711: [NO DATA] RL	—	×	
C1716: [PRESS DATA ERR] FL	—	×	<a href="#">WT-35</a>
C1717: [PRESS DATA ERR] FR	—	×	
C1718: [PRESS DATA ERR] RR	—	×	
C1719: [PRESS DATA ERR] RL	—	×	
C1729: VHCL SPEED SIG ERR	—	×	<a href="#">WT-37</a>
C1734: CONTROL UNIT	—	×	<a href="#">WT-39</a>
C1735: IGN CIRCUIT OPEN	—	—	<a href="#">BCS-117</a>

# MANUAL AIR CONDITIONING SYSTEM

< SYMPTOM DIAGNOSIS >

[MANUAL AIR CONDITIONING]

## SYMPTOM DIAGNOSIS

### MANUAL AIR CONDITIONING SYSTEM

#### Diagnosis Chart By Symptom

INFOID:000000005490159

**CAUTION:**

Perform the self-diagnosis with CONSULT-III before performing the symptom diagnosis. If any malfunction result or DTC is detected, perform the corresponding diagnosis.

Symptom	Corresponding malfunction part	Check item/Reference
Blower motor operation is malfunctioning.	<ul style="list-style-type: none"> <li>Blower motor</li> <li>Power supply system of blower motor</li> <li>The circuit between blower motor and fan switch.</li> <li>The circuit between blower motor and blower fan resistor.</li> <li>Blower fan resistor.</li> <li>Fan switch (A/C control).</li> </ul>	<a href="#">HAC-175, "Diagnosis Procedure"</a>
A/C indicator dose not indicate. (Compressor is normal)	<ul style="list-style-type: none"> <li>A/C indicator (A/C control)</li> <li>The circuit between A/C control and BCM</li> <li>BCM</li> </ul>	<a href="#">HAC-184, "Diagnosis Procedure"</a>
Magnet clutch does not operate. (Compressor is normal)	<ul style="list-style-type: none"> <li>Magnet clutch</li> <li>The circuit between magnet clutch and IPDM E/R</li> <li>IPDM E/R (A/C relay)</li> <li>The circuit between ECM and refrigerant pressure sensor</li> <li>Refrigerant pressure sensor</li> <li>CAN communication line</li> <li>A/C switch</li> <li>Blower fan ON signal</li> <li>Thermo control amp.</li> <li>BCM</li> </ul>	<a href="#">HAC-219, "Diagnosis Procedure"</a>
<ul style="list-style-type: none"> <li>Insufficient cooling</li> <li>No cool air comes out. (Air flow volume is normal.)</li> </ul>	<ul style="list-style-type: none"> <li>Magnet clutch control system</li> <li>Drive belt slipping</li> <li>Cooler cycle</li> <li>Air leakage from each duct</li> </ul>	<a href="#">HAC-217, "Diagnosis Procedure"</a>
<ul style="list-style-type: none"> <li>Insufficient heating</li> <li>No warm air comes out. (Air flow volume is normal.)</li> </ul>	<ul style="list-style-type: none"> <li>Engine cooling system</li> <li>Heater hose</li> <li>Heater core</li> <li>Air leakage from each duct</li> </ul>	<a href="#">HAC-218, "Diagnosis Procedure"</a>
Noise is heard when the A/C system operates.	During compressor operation	Cooler cycle <a href="#">HA-10, "Symptom Table"</a>
	During blower motor operation	<ul style="list-style-type: none"> <li>Mixing any foreign object in blower motor</li> <li>Blower motor fan breakage</li> <li>Blower motor rotation inferiority</li> </ul> <a href="#">HAC-177, "Component Inspection"</a>
Air inlet dose not change.	<ul style="list-style-type: none"> <li>A/C control</li> <li>Intake door motor</li> <li>Intake door</li> </ul>	<a href="#">HAC-170, "Diagnosis Procedure"</a>
Discharge air temperature dose not change.	<ul style="list-style-type: none"> <li>A/C control</li> <li>Air mix door cable</li> <li>Air mix door</li> </ul>	Check the air mix door installation and door operation

A  
B  
C  
D  
E  
F  
G  
H  
J  
K  
L  
M  
N  
O  
P

HAC

# MANUAL AIR CONDITIONING SYSTEM

< SYMPTOM DIAGNOSIS >

[MANUAL AIR CONDITIONING]

Symptom	Corresponding malfunction part	Check item/Reference
Air outlet dose not change.	<ul style="list-style-type: none"><li>• A/C control</li><li>• Mode door cable</li><li>• Mode door</li></ul>	Check the mode door installation and door operation
When the MODE dial is set to D/F or DEF, there is the malfunctions as follows: <ul style="list-style-type: none"><li>• The A/C switch indicator dose not turn ON.</li><li>• Air inlet does not becomes REC to FRE.</li></ul>	<ul style="list-style-type: none"><li>• A/C control</li><li>• BCM</li></ul>	<a href="#">HAC-186, "Diagnosis Procedure"</a>



## INSUFFICIENT COOLING

## Description

INFOID:000000005490160

## Symptom

- Insufficient cooling
- No cool air comes out. (Air flow volume is normal.)

## Diagnosis Procedure

INFOID:000000005490161

**CAUTION:**

Perform the self-diagnosis with CONSULT-III before performing symptom diagnosis. If any malfunction result or DTC is detected, perform the corresponding diagnosis.

**1**.CHECK MAGNET CLUTCH OPERATION

1. Turn the ignition switch ON.
2. Turn the fan control dial ON.
3. Press the A/C switch.
4. Check that the indicator of the A/C switch turns ON. Check visually and by sound that the compressor operates.
5. Press the A/C switch again.
6. Check that the indicator of the A/C switch turns OFF. Check that the compressor stops.

Is the inspection result normal?

YES &gt;&gt; GO TO 2.

NO >> Perform the diagnosis of "COMPRESSOR DOSE NOT OPERATE" in "SYMPTOM DIAGNOSIS".  
Refer to [HAC-219. "Diagnosis Procedure"](#).

**2**.CHECK DRIVE BELT

Check tension of the drive belt. Refer to [EM-13. "Checking"](#).

Is the inspection result normal?

YES &gt;&gt; GO TO 3.

NO &gt;&gt; Adjust or replace drive belt depending on the inspection results.

**3**.CHECK REFRIGERANT CYCLE PRESSURE

Connect the recovery/recycling recharging equipment to the vehicle and perform the pressure inspection with the gauge. Refer to [HA-8. "Symptom Table"](#).

Is the inspection result normal?

YES &gt;&gt; GO TO 4.

NO &gt;&gt; Repair or replace parts depending on the inspection results.

**4**.CHECK AIR LEAKAGE FROM EACH DUCT

Check duct and nozzle, etc. of the air conditioner system for leakage.

Is the inspection result normal?

YES &gt;&gt; Check the air mix door cable installation and air mix door operation.

NO &gt;&gt; Repair or replace parts depending on the inspection results.

A  
B  
C  
D  
E  
F  
G  
H  
HAC  
J  
K  
L  
M  
N  
O  
P

## INSUFFICIENT HEATING

## Description

INFOID:000000005490162

## Symptom

- Insufficient heating
- No warm air comes out. (Air flow volume is normal.)

## Diagnosis Procedure

INFOID:000000005490163

**CAUTION:**

Perform the self-diagnosis with CONSULT-III before performing symptom diagnosis. If any malfunction result or DTC is detected, perform the corresponding diagnosis.

**1**.CHECK COOLING SYSTEM

1. Check the engine coolant level and check for leakage. Refer to [CO-9, "Inspection"](#).
2. Check the radiator cap. Refer to [CO-12, "RADIATOR CAP : Inspection"](#).
3. Check the water flow sounds of the engine coolant. Refer to [CO-10, "Refilling"](#).

Is the inspection result normal?

- YES >> GO TO 2.  
NO >> Refill the engine coolant and repair or replace the parts depending on the inspection results.

**2**.CHECK HEATER HOSE

Check the installation of heater hose by visually or touching.

Is the inspection result normal?

- YES >> GO TO 3.  
NO >> Repair or replace parts depending on the inspection results.

**3**.CHECK HEATER CORE

1. Check the temperature of inlet hose and outlet hose of heater core.
2. Check that the inlet side of heater core is hot and the outlet side is slightly lower than/almost equal to the inlet side.

**CAUTION:**

Always perform the temperature inspection in a short period of time because the engine coolant temperature is very hot.

Is the inspection result normal?

- YES >> GO TO 4.  
NO >> Replace the heater core. Refer to [HA-42, "Exploded View \(Manual Air Conditioner\)"](#).

**4**.CHECK AIR LEAKAGE FROM EACH DUCT

Check duct and nozzle, etc. of the air conditioner system for air leakage.

Is the inspection result normal?

- YES >> Check the air mix door cable installation and air mix door operation.  
NO >> Repair or replace parts depending on the inspection results.

# COMPRESSOR DOSE DOT OPERATE

[MANUAL AIR CONDITIONING]

< SYMPTOM DIAGNOSIS >

## COMPRESSOR DOSE DOT OPERATE

### Description

INFOID:000000005490164

### SYMPTOM

Compressor dose not operate.

### Diagnosis Procedure

INFOID:000000005490165

#### CAUTION:

- Perform the self-diagnosis with CONSULT-III before performing symptom diagnosis. If any malfunction result or DTC is detected, perform the corresponding diagnosis.
- Check that the refrigerant is enclosed in cooler cycle normally. If the refrigerant amount is shortage from proper amount, perform the inspection of refrigerant leakage

#### 1. CHECK A/C INDICATOR

1. Turn the ignition switch ON.
2. Operate the blower motor.
3. Check that A/C indicator is turned ON when pressing the A/C switch.
4. Check that A/C indicator is turned OFF when pressing the A/C switch again.

Is inspection result normal?

- YES >> GO TO 2.  
NO >> GO TO 5.

#### 2. CHECK MAGNET CLUTCH OPERATION

Check the magnet clutch. Refer to [HAC-179, "Component Function Check"](#).

Does it operate normally?

- YES >> GO TO 3.  
NO >> Repair or replace the malfunctioning parts.

#### 3. CHECK REFRIGERANT PRESSURE SENSOR

Check the refrigerant pressure sensor. Refer to [EC-415, "Diagnosis Procedure"](#).

Is the inspection result normal?

- YES >> GO TO 4.  
NO >> Repair or replace the malfunctioning parts.

#### 4. CHECK BCM OUTPUT SIGNAL

Ⓜ With CONSULT-III

Check the "A/C ON SIG" or "FAN ON SIG" or "A/C RELAY SIG" in ECM.

Monitor item	Condition	Status
COMP REQ SIG	A/C switch: OFF	Off
	A/C switch: ON	On
FAN REQ SW	Fan control dial: OFF	Off
	Fan control dial: ON	On

Is the inspection result normal?

- YES >> Replace the IPDM E/R. Refer to [PCS-64, "Exploded View"](#).  
NO >> Replace the BCM. Refer to [BCS-146, "Exploded View"](#).

#### 5. CHECK A/C SWITCH

Check the A/C switch. Refer to [HAC-180, "Diagnosis Procedure"](#).

Is inspection result normal?

- YES >> GO TO 6.  
NO >> Repair or replace the malfunctioning parts.

#### 6. CHECK BLOWER FAN ON SIGNAL

## COMPRESSOR DOSE DOT OPERATE

[MANUAL AIR CONDITIONING]

< SYMPTOM DIAGNOSIS >

---

Check the blower fan ON signal. Refer to [HAC-186. "Diagnosis Procedure"](#).

Is the inspection result normal?

YES >> GO TO 7.

NO >> Repair or replace the malfunctioning parts

**7**.CHECK THERMO CONTROL AMP.

---

Check the thermo control amp. Refer to [HAC-172. "Diagnosis Procedure"](#).

Is the inspection result normal?

YES >> Replace the BCM. Refer to [BCS-146. "Exploded View"](#).

NO >> Repair or replace the malfunctioning parts

PRECAUTION

PRECAUTIONS

Precaution for Supplemental Restraint System (SRS) "AIR BAG" and "SEAT BELT PRE-TENSIONER"

INFOID:000000005490166

The Supplemental Restraint System such as "AIR BAG" and "SEAT BELT PRE-TENSIONER", used along with a front seat belt, helps to reduce the risk or severity of injury to the driver and front passenger for certain types of collision. This system includes seat belt switch inputs and dual stage front air bag modules. The SRS system uses the seat belt switches to determine the front air bag deployment, and may only deploy one front air bag, depending on the severity of a collision and whether the front occupants are belted or unbelted. Information necessary to service the system safely is included in the "SRS AIR BAG" and "SEAT BELT" of this Service Manual.

**WARNING:**

- To avoid rendering the SRS inoperative, which could increase the risk of personal injury or death in the event of a collision which would result in air bag inflation, all maintenance must be performed by an authorized NISSAN/INFINITI dealer.
- Improper maintenance, including incorrect removal and installation of the SRS, can lead to personal injury caused by unintentional activation of the system. For removal of Spiral Cable and Air Bag Module, see the "SRS AIR BAG".
- Do not use electrical test equipment on any circuit related to the SRS unless instructed to in this Service Manual. SRS wiring harnesses can be identified by yellow and/or orange harnesses or harness connectors.

PRECAUTIONS WHEN USING POWER TOOLS (AIR OR ELECTRIC) AND HAMMERS

**WARNING:**

- When working near the Air Bag Diagnosis Sensor Unit or other Air Bag System sensors with the ignition ON or engine running, DO NOT use air or electric power tools or strike near the sensor(s) with a hammer. Heavy vibration could activate the sensor(s) and deploy the air bag(s), possibly causing serious injury.
- When using air or electric power tools or hammers, always switch the ignition OFF, disconnect the battery, and wait at least 3 minutes before performing any service.

Precaution Necessary for Steering Wheel Rotation after Battery Disconnect

INFOID:000000005490167

**NOTE:**

- Before removing and installing any control units, first turn the push-button ignition switch to the LOCK position, then disconnect both battery cables.
- After finishing work, confirm that all control unit connectors are connected properly, then re-connect both battery cables.
- Always use CONSULT-III to perform self-diagnosis as a part of each function inspection after finishing work. If a DTC is detected, perform trouble diagnosis according to self-diagnosis results.

For vehicle with steering lock unit, if the battery is disconnected or discharged, the steering wheel will lock and cannot be turned.

If turning the steering wheel is required with the battery disconnected or discharged, follow the operation procedure below before starting the repair operation.

OPERATION PROCEDURE

1. Connect both battery cables.
  - NOTE:**  
Supply power using jumper cables if battery is discharged.
2. Turn the push-button ignition switch to ACC position.  
(At this time, the steering lock will be released.)
3. Disconnect both battery cables. The steering lock will remain released with both battery cables disconnected and the steering wheel can be turned.
4. Perform the necessary repair operation.

A  
B  
C  
D  
E  
F  
G  
H  
HAC  
J  
K  
L  
M  
N  
O  
P

## PRECAUTIONS

< PRECAUTION >

[MANUAL AIR CONDITIONING]

---

5. When the repair work is completed, re-connect both battery cables. With the brake pedal released, turn the push-button ignition switch from ACC position to ON position, then to LOCK position. (The steering wheel will lock when the push-button ignition switch is turned to LOCK position.)
6. Perform self-diagnosis check of all control units using CONSULT-III.

# REMOVAL AND INSTALLATION

## A/C CONTROL

### Exploded View

INFOID:000000005490168

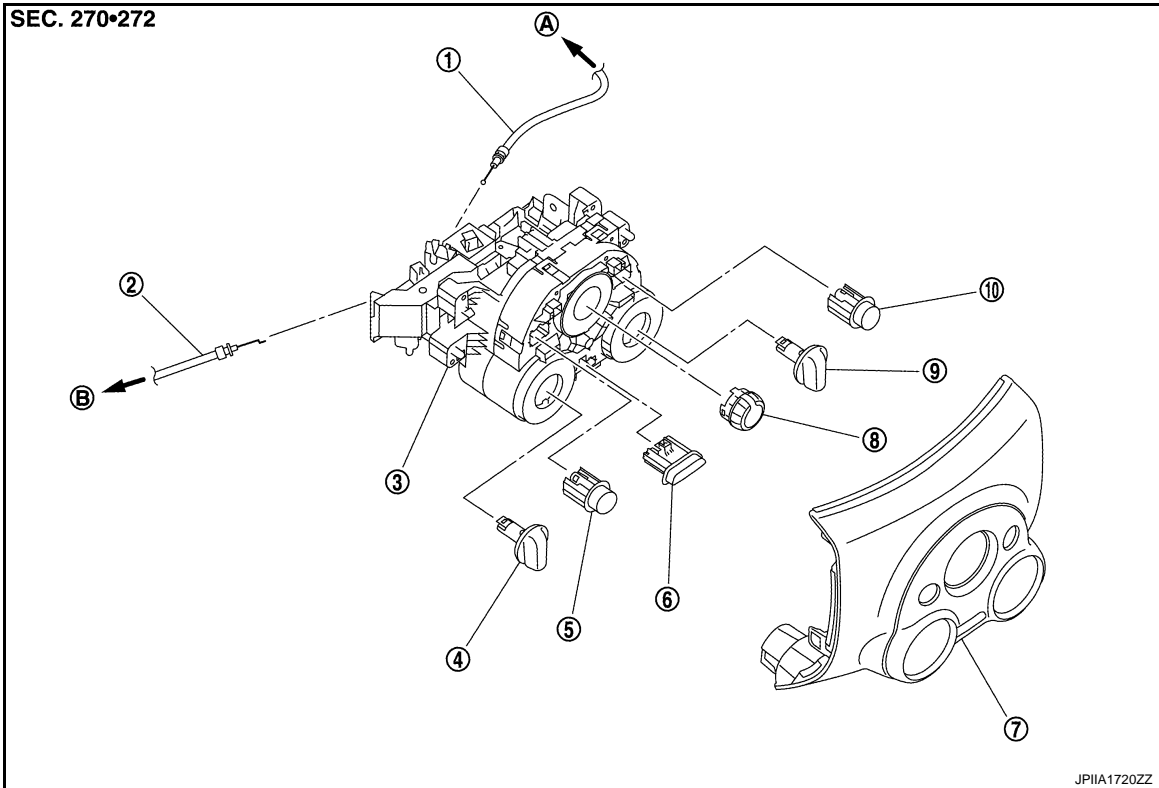

- |                      |                                |                     |
|----------------------|--------------------------------|---------------------|
| 1. Mode door cable   | 2. Air mix door cable          | 3. A/C control      |
| 4. Mode dial         | 5. Rear window defogger switch | 6. Intake switch    |
| 7. A/C finisher      | 8. Fan control dial            | 9. Temperature dial |
| 10. A/C switch       |                                |                     |
| A. To mode door link | B. To air mix door link        |                     |

### Removal and Installation

INFOID:000000005490169

#### REMOVAL

1. Remove A/C finisher. Refer to [IP-12, "Exploded View"](#).
2. Remove the A/C control mounting screws.
3. Remove the air mix door cable from the A/C unit assembly. Refer to [HAC-231, "AIR MIX DOOR CABLE : Removal and Installation"](#).
4. Remove the mode door cable from the A/C unit assembly. Refer to [HAC-231, "MODE DOOR CABLE : Removal and Installation"](#).
5. Disconnect harness connector.

## A/C CONTROL

### < REMOVAL AND INSTALLATION >

### [MANUAL AIR CONDITIONING]

6. Turn the A/C control (1) as the following figure.
7. Remove the A/C control.

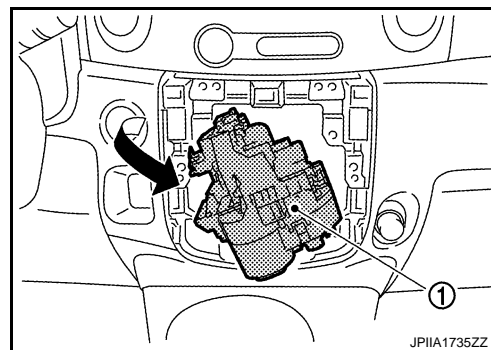

### INSTALLATION

Installation is basically the reverse order of removal.



# THERMO CONTROL AMPLIFIER

< REMOVAL AND INSTALLATION >

[MANUAL AIR CONDITIONING]

## THERMO CONTROL AMPLIFIER

### Exploded View

INFOID:000000005490170

Refer to [HA-42, "Exploded View \(Manual Air Conditioner\)"](#).

### Removal and Installation

INFOID:000000005490171

#### REMOVAL

1. Remove the evaporator. Refer to [HA-42, "Exploded View \(Manual Air Conditioner\)"](#).
2. Remove the thermo control amp. from the evaporator.

#### INSTALLATION

Installation is basically the reverse order of removal.

#### **CAUTION:**

- Replace O-ring with new one. Then apply compressor oil to them when installing.
- When install the thermo control amp., set the same position before replacement.
- When remove the thermo control amp., never turn the bracket which is equipped the top of the thermo control amp.
- Check for the leakages when recharging refrigerant. Refer to [HA-22, "Leak Test"](#).

A

B

C

D

E

F

G

H

HAC

J

K

L

M

N

O

P

# REFRIGERANT PRESSURE SENSOR

< REMOVAL AND INSTALLATION >

[MANUAL AIR CONDITIONING]

## REFRIGERANT PRESSURE SENSOR

Exploded View

INFOID:000000005490172

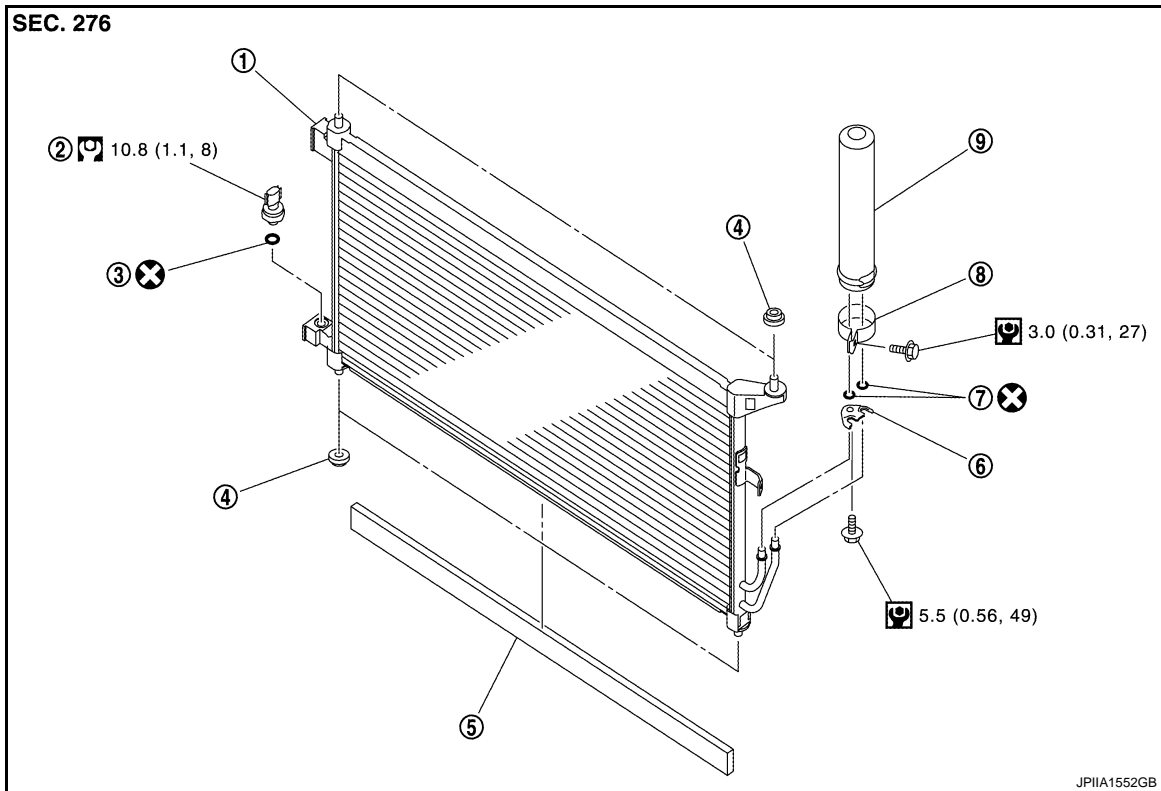

- |              |                                |                |
|--------------|--------------------------------|----------------|
| 1. Condenser | 2. Refrigerant pressure sensor | 3. O-ring      |
| 4. Grommet   | 5. Condenser seal              | 6. Bracket     |
| 7. O-ring    | 8. Liquid tank bracket         | 9. Liquid tank |

Refer to [GI-4. "Components"](#) for symbols in the figure.

### Removal and Installation

INFOID:000000005490173

#### CAUTION:

Perform lubricant return operation before each refrigeration system disassembly. However, if a large amount of refrigerant or lubricant is detected, never perform lubricant return operation. Refer to [HA-26. "Perform Lubricant Return Operation"](#).

#### REMOVAL

1. Use a refrigerant collecting equipment (for HFC-134a) to discharge the refrigerant. Refer to [HA-24. "Recycle Refrigerant"](#).
2. Clean refrigerant pressure sensor and its surrounding area, and then remove dust and rust from refrigerant pressure sensor.

#### CAUTION:

**Be sure to clean carefully.**

3. Disconnect refrigerant pressure sensor connector.

# REFRIGERANT PRESSURE SENSOR

< REMOVAL AND INSTALLATION >

[MANUAL AIR CONDITIONING]

4. Use a adjustable wrench (A) or other tool to hold the refrigerant pressure sensor mounting block, and then remove the refrigerant pressure sensor (2) from the condenser (1).

**CAUTION:**

- Be careful not to damage liquid tank.
- Be careful not to damage core surface of condenser.
- Cap or wrap the joint of the condenser and liquid tank with suitable material such as vinyl tape to avoid the entry of air.

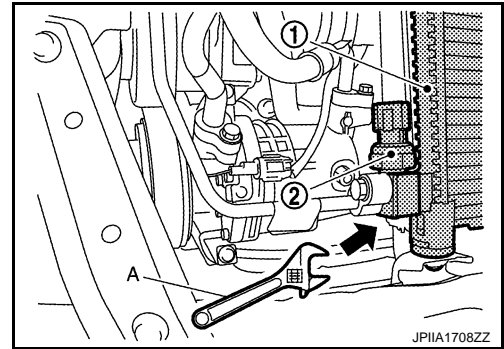

## INSTALLATION

Installation is basically the reverse order of removal.

**CAUTION:**

- Replace O-ring with new one. Then apply compressor oil to them when installing.
- Check for leakages when recharging refrigerant. Refer to [HA-22, "Leak Test"](#).

A  
B  
C  
D  
E  
F  
G  
H  
HAC  
J  
K  
L  
M  
N  
O  
P

HAC

# BLOWER FAN RESISTOR

< REMOVAL AND INSTALLATION >

[MANUAL AIR CONDITIONING]

## BLOWER FAN RESISTOR

### Exploded View

INFOID:000000005490174

Refer to [VTL-13, "Exploded View"](#)

### Removal and Installation

INFOID:000000005490175

#### REMOVAL

1. Remove instrument panel assembly. Refer to [IP-12, "Exploded View"](#).
2. Remove cowl top extension. Refer to [EXT-20, "Exploded View"](#).
3. Remove instrument stay.
4. Remove mounting bolts (A), and then move steering member (1) to a position where it does not inhibit work.

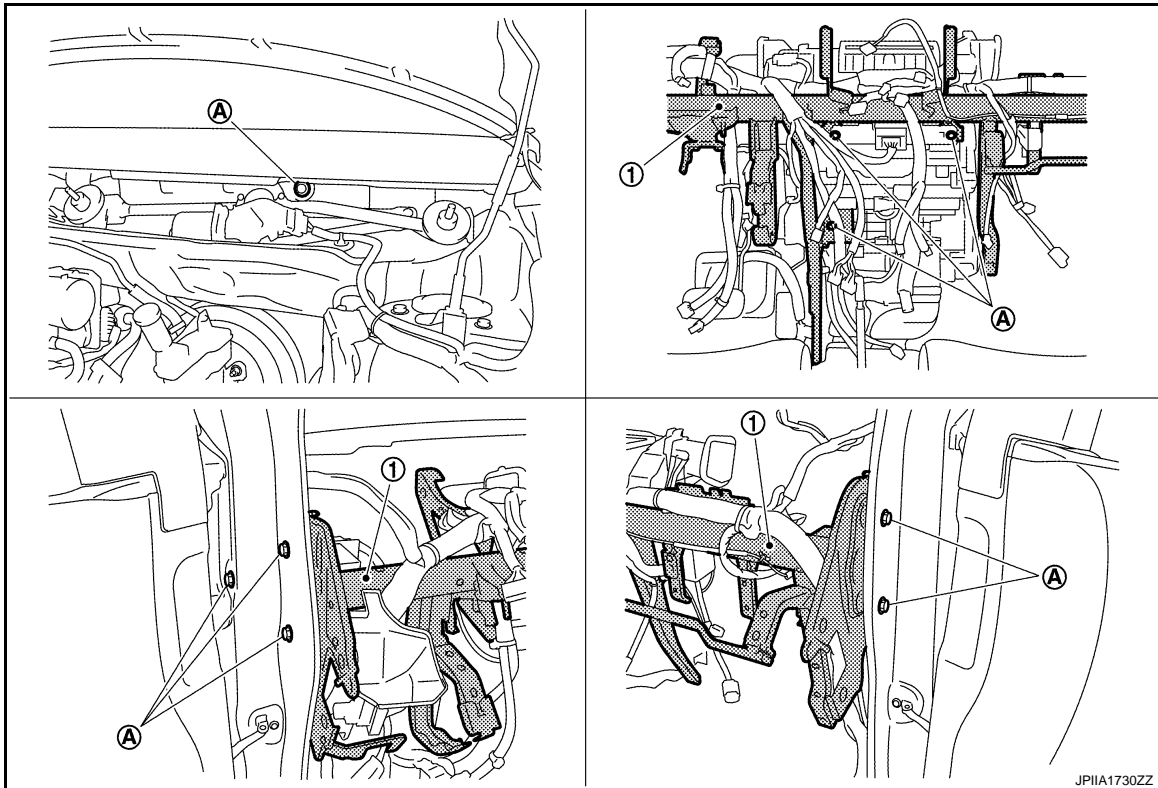

5. Disconnect blower fan resistor connector.
6. Remove mounting screws (A), and then remove blower fan resistor (1).

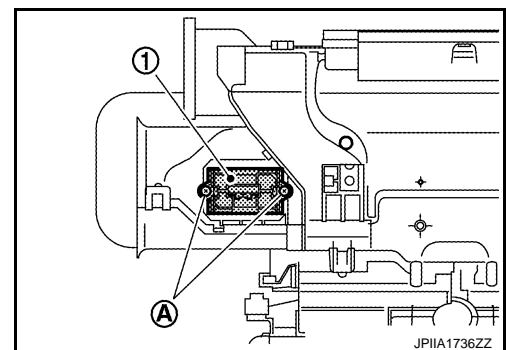

#### INSTALLATION

Installation is basically the reverse order of removal.

# INTAKE DOOR MOTOR

< REMOVAL AND INSTALLATION >

[MANUAL AIR CONDITIONING]

## INTAKE DOOR MOTOR

Exploded View

INFOID:000000005490176

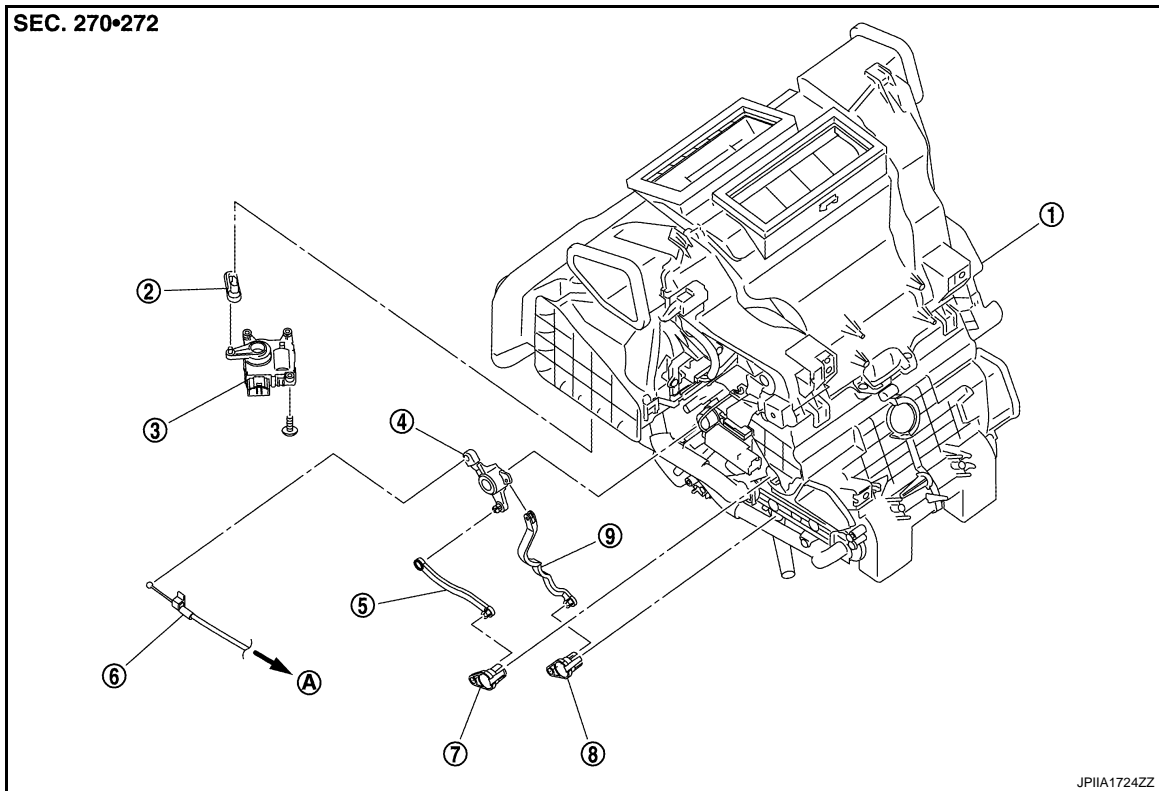

- |                             |                             |                           |
|-----------------------------|-----------------------------|---------------------------|
| 1. A/C unit assembly        | 2. Intake door lever        | 3. Intake door motor      |
| 4. Air mix door link        | 5. Upper air mix door rod   | 6. Air mix door cable     |
| 7. Upper air mix door lever | 8. Lower air mix door lever | 9. Lower air mix door rod |
| A. To A/C control           |                             |                           |

### Removal and Installation

INFOID:000000005490177

#### REMOVAL

1. Remove foot duct LH. Refer to [VTL-7. "Exploded View"](#).
2. Remove mounting screws (A), and then remove intake door motor (1).
3. Disconnect intake door motor connector.

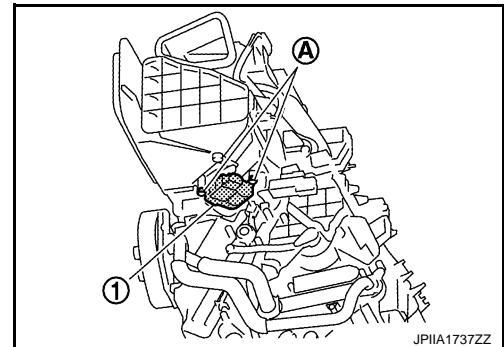

#### INSTALLATION

Installation is basically the reverse order of removal.

A  
B  
C  
D  
E  
F  
G  
H  
HAC  
J  
K  
L  
M  
N  
O  
P

# DOOR CABLE

< REMOVAL AND INSTALLATION >

[MANUAL AIR CONDITIONING]

## DOOR CABLE

Exploded View

INFOID:000000005490178

LEFT SIDE

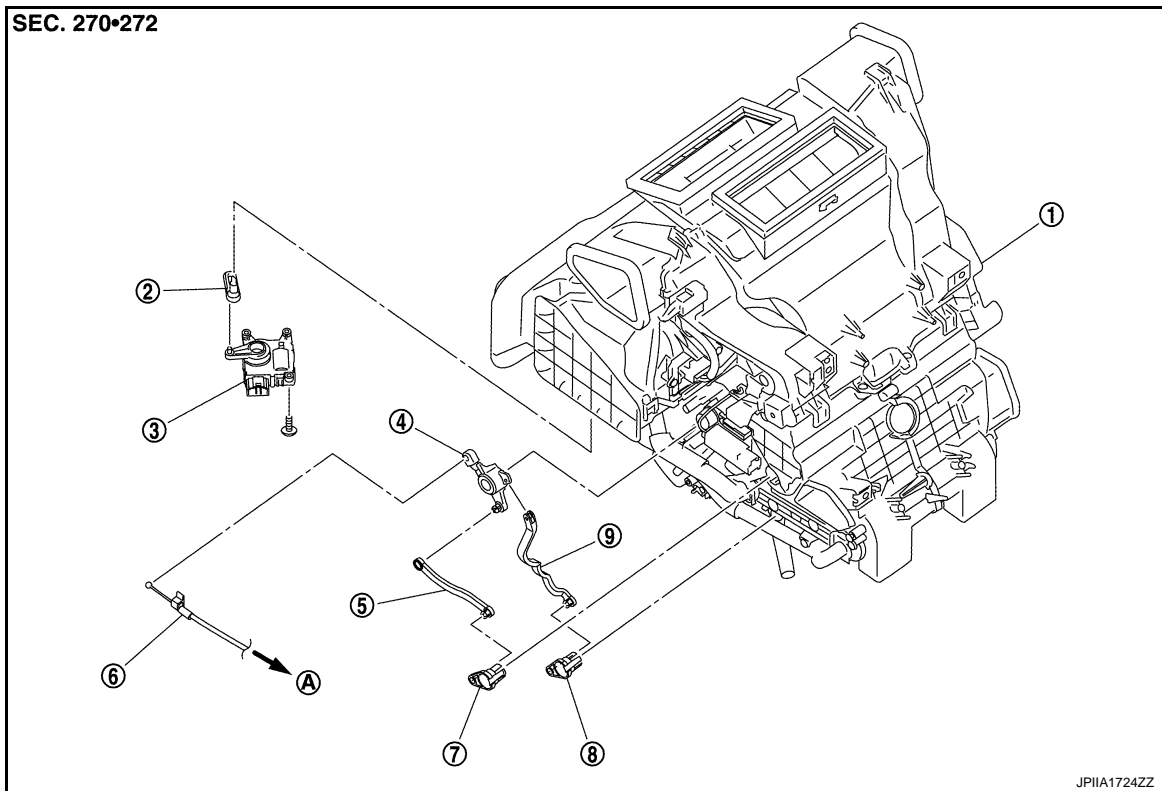

- |                             |                             |                           |
|-----------------------------|-----------------------------|---------------------------|
| 1. A/C unit assembly        | 2. Intake door lever        | 3. Intake door motor      |
| 4. Air mix door link        | 5. Upper air mix door rod   | 6. Air mix door cable     |
| 7. Upper air mix door lever | 8. Lower air mix door lever | 9. Lower air mix door rod |
| A. To A/C control           |                             |                           |

RIGHT SIDE

# DOOR CABLE

< REMOVAL AND INSTALLATION >

[MANUAL AIR CONDITIONING]

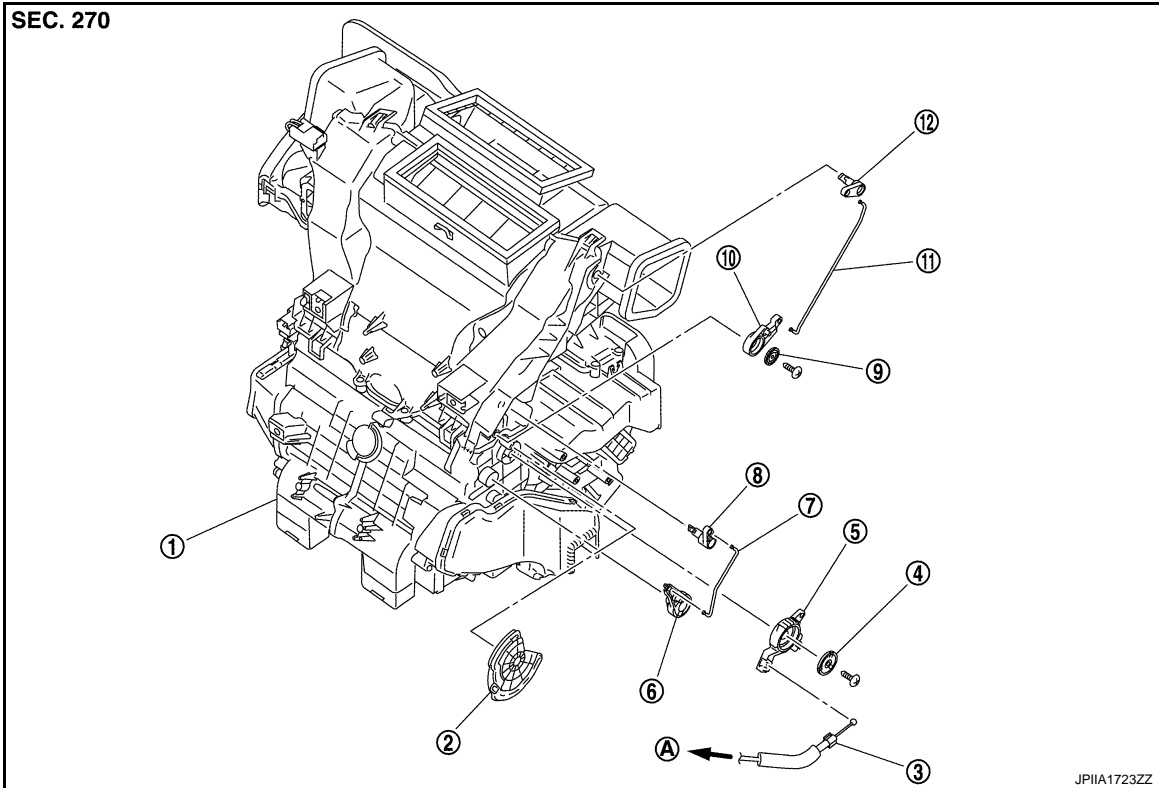

- |   |  |  |
|---|--|--|
| 1. A/C unit assembly                          | 2. Main link                                 | 3. Mode door cable                             |
| 4. Plate                                      | 5. Mode door link                            | 6. Sub defroster door link                     |
| 7. Sub defroster door rod                     | 8. Sub defroster door lever                  | 9. Plate                                       |
| 10. Center ventilator and defroster door link | 11. Center ventilator and defroster door rod | 12. Center ventilator and defroster door lever |
- A. To A/C control

## MODE DOOR CABLE

### MODE DOOR CABLE : Removal and Installation

INFOID:000000005490179

1. Disconnect mode door cable from A/C control. Refer to [HAC-223, "Exploded View"](#).
2. Remove glove box assembly. Refer to [IP-12, "Exploded View"](#).
3. Remove the clamp (A) in the direction shown by the arrow, and the remove mode door cable (1) from the A/C unit assembly.

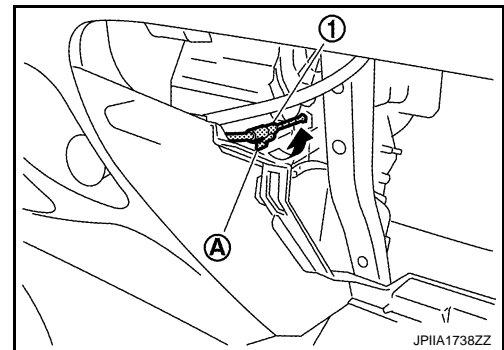

## INSTALLATION

Installation is basically the reverse order of removal.

## AIR MIX DOOR CABLE

### AIR MIX DOOR CABLE : Removal and Installation

INFOID:000000005490180

1. Disconnect air mix door cable from A/C control. Refer to [HAC-223, "Exploded View"](#).

## DOOR CABLE

### < REMOVAL AND INSTALLATION >

[MANUAL AIR CONDITIONING]

2. Remove foot duct LH. Refer to [VTL-7, "Exploded View"](#).
3. Remove the clamp (A) in the direction shown by the arrow, and then remove air mix door cable (1) from the A/C unit assembly.

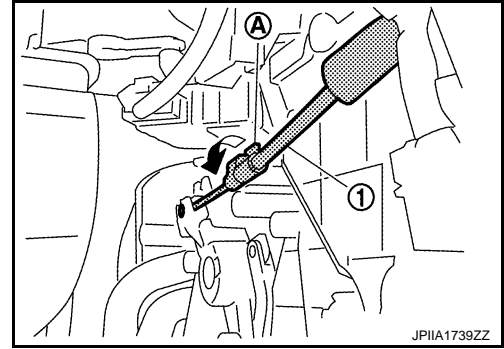

### INSTALLATION

Installation is basically the reverse order of removal.